

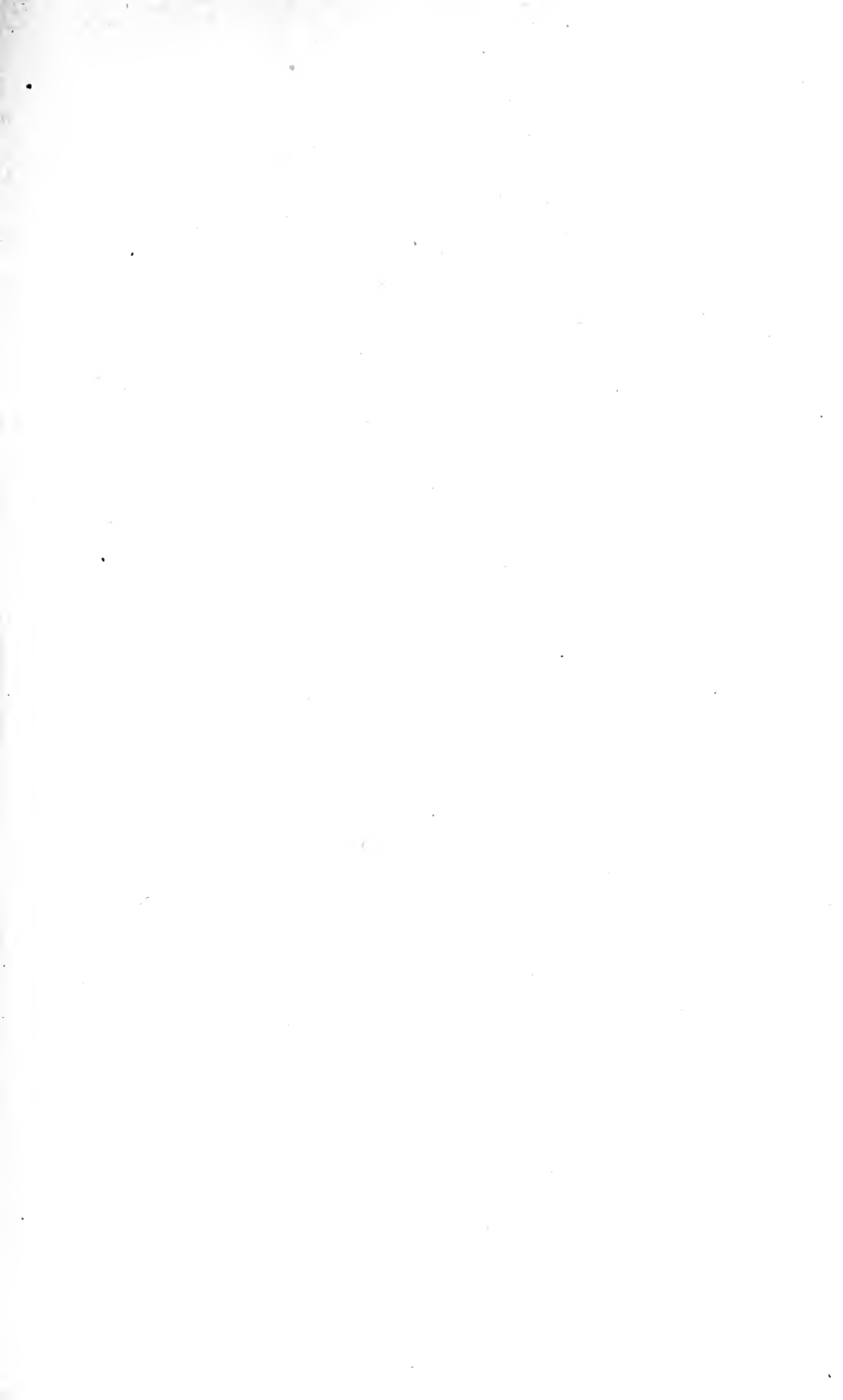

GIFT OF  
*C. W. Merrill.*



*Mining Department.*



Digitized by the Internet Archive  
in 2006 with funding from  
Microsoft Corporation



# HIGH-SPEED STEEL

# McGraw-Hill Book Company

*Publishers of Books for*

Electrical World	The Engineering and Mining Journal
Engineering Record	Engineering News
Railway Age Gazette	American Machinist
Signal Engineer	American Engineer
Electric Railway Journal	Coal Age
Metallurgical and Chemical Engineering	Power



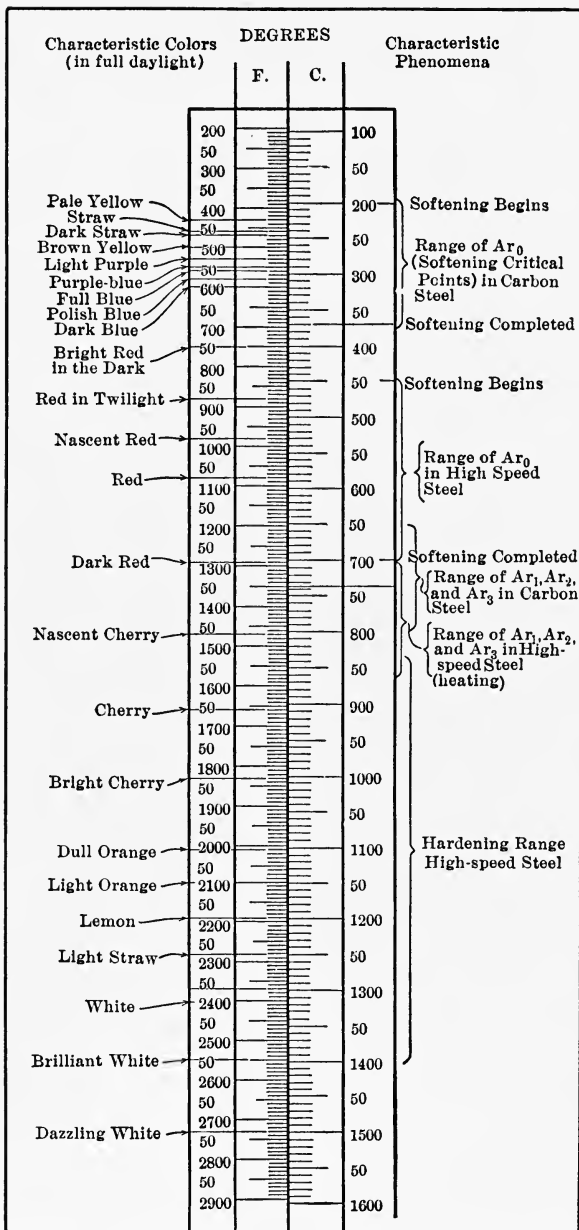

Frontispiece

Heating Phenomena, Fahrenheit and Centigrade Scales.

# HIGH-SPEED STEEL

THE DEVELOPMENT, NATURE, TREATMENT, AND  
USE OF HIGH-SPEED STEELS, TOGETHER  
WITH SOME SUGGESTIONS AS TO  
THE PROBLEMS INVOLVED  
IN THEIR USE

BY

O. M. BECKER

*Industrial Engineer*



FIRST EDITION  
SECOND IMPRESSION

McGRAW-HILL BOOK COMPANY, INC.

239 WEST 39TH STREET, NEW YORK

6 BOUVERIE STREET, LONDON, E. C.

1910

75320

E3

MINING DEPT.

COPYRIGHT, 1910,  
BY THE  
MCGRAW-HILL BOOK COMPANY

*Handwritten:*  
Library of  
Geological Survey  
of the United States

Stanbope Press  
F. H. GILSON COMPANY  
BOSTON, U.S.A

## INTRODUCTION

---

It is rather unusual that any considerable time should elapse between the announcement of a great discovery and the appearance of a book dealing specifically and comprehensively with the subject of that discovery; and especially is this true when the idea or invention has such a far-reaching, even revolutionary, influence in its particular department of the world's activities as is the case with high-speed steels. Nevertheless during the decade and more since Fred W. Taylor and Maunsel White unexpectedly stumbled upon the high-heat treatment for tungsten and related steels, and developed their high-speed steel, nothing has been published which could be called at all adequate as a treatment of the subject, except possibly Mr. Taylor's address before the American Society of Mechanical Engineers on the occasion of his inauguration as president, at the December, 1906, meeting; and the articles hereafter mentioned. This address or report is indeed a monumental work, including as it does the results of his experiences and researches, and those of his co-laborers, in the carrying on of his investigations. These researches, it would seem, have been more extensive and thorough than any others yet attempted, covering the general subject of the new steels. Other investigations, covering limited portions of the field, like those of Dr. H. C. H. Carpenter, say, have been exhaustive as far as they extended, and also are very valuable for the light they throw upon the nature and the possibilities of high-speed steel.

The Taylor report confines itself largely to the experiences of its author and his associates, and unfortunately, has not a good index. There has been a pretty general feeling for some time that a work should be available which would cover comprehensively the whole subject of high-speed steels, presenting in an understandable way a general view of it in such form as to be easily accessible for reference. This was in the mind of the present writer when he was invited some five years ago to contribute to the *Engineering Magazine* a series of papers dealing with the subject. The articles were written and printed,<sup>1</sup> and, as far as appears, formed the most extensive account of the new steels, as adaptable to use in productive industry, which had been published up to that time.

<sup>1</sup> *Engineering Magazine*, New York and London. Issues of September, October, November, and December, 1905; May, June, and August, 1906.

Since the original articles appeared much new light has been thrown upon certain aspects of the subject. Mr. Taylor's address has been published, and many sporadic contributions of greater or less value have appeared in the technical periodicals. Furthermore, important developments have been worked out concerning which little or nothing at all has been heretofore printed. While therefore this book is in a sense based upon the series of articles already mentioned, it is by no means the same. Such of the original material as has proved fundamental has been retained and brought into accord with present knowledge and practice. Much has been added touching the historical and theoretical aspects of high-speed and other tool steels. The purpose has been to include all that might be of interest in connection with the subject and to present an accurate conspectus of the present state of knowledge concerning the new steels.

The entire subject is so recent, however, and astonishing developments have followed one another with such bewildering rapidity, that the accomplishing of this purpose presented many difficulties. Almost every steel man knows the practical impossibility of obtaining detailed information concerning tool steels which is absolutely accurate and reliable. The personal equation and a multitude of other factors commonly accounted negligible, so much affect results that the assertion might be safely hazarded that all conclusions as to method and means in steel treatment are subject to allowances for these elements. Thus, for illustration, two different plants operated by the same concern make large use of the barium process in hardening. At one the temperature commonly maintained and indicated by the pyrometer is 1200 degrees C. (2200 F.), while at the other an instrument of the same make and calibrated with equal care uniformly indicates only 1070 degrees C. (1950 F.); and yet as far as can be seen by the eye of an experienced operator, familiar with both plants, the two baths are kept at identical temperatures. Certain it is that results equally good are obtained at both plants.

Similar difficulties arise in connection with methods and apparatus. Thus, it is maintained with much fervor by some that the only furnace giving good results is coke-fired; while others insist with equal fervor that oil or gas fired furnaces alone can be depended upon. Similarly, conclusions as to superiority of one or another brand of steel over others are almost uniformly based on insufficient grounds or arrived at under conditions not precisely duplicated (or not likely to be duplicated) elsewhere.

Great care has been taken to insure absolute accuracy of statement, and definiteness in every respect. The reader must remember, however, that in view of the considerations just set forth, there may be some disagreement with methods here proposed and conclusions presented. The endeavor has been not only to cover, in the chapters dealing with the practical handling of the new steels, all points likely to come up, and to indicate clearly just what is believed to be best practice at the present time; but, where



there is diversity of opinion, to describe all practical methods shown to yield satisfactory results.

In conclusion the author wishes to express his appreciation of the assistance rendered by Mr. Walter Brown and Mr. D. G. Clark. Except for their encouragement and patient assistance during the early days of the work the task, if undertaken at all, might never have been finished. Grateful acknowledgment is also made of the interest manifested and assistance rendered in the ways of suggestions, criticism, permission to use material, and proof reading by Mr. Fred W. Taylor, Dr. H. C. H. Carpenter, Mr. George H. Paltridge, Dr. Bradley Stoughton, and others. Dr. Carpenter was especially helpful with suggestions in connection with the chapter on the Nature and Characteristics of the New Steels; and Dr. Stoughton was kind enough to revise portions of the same. Acknowledgment for the use of illustrations is made in the appropriate places.

O. M. BECKER.

CHICAGO, ILL.,  
*July 1, 1910.*



# CONTENTS

	PAGE
Introduction .....	iii
Section I. The Development and Nature of High-Speed Steels.	
Early Tool Steels .....	1
Self-Hardening and High-Speed Steels .....	13
Nature and Characteristics of the New Steels .....	22
Still Newer Steels .....	49
Section II. Making the Steels and Tools.	
Process of Making High-Speed Steel .....	55
Forging the Tools .....	64
Hardening — The High Treatment Practically Applied .....	78
Hardening — The Barium Chloride Process .....	105
Tempering .....	121
Annealing .....	129
Grinding .....	134
Ascertaining and Regulating Temperatures .....	155
Miscellaneous Observations on the Making of High-Speed Tools .....	178
Section III. The Tool at Work.	
Range of Utility of High-Speed Steel .....	186
Conditions of Maximum Effect .....	212
Speeds and Feeds, and Related Matters .....	235
Section IV. The New Requirements.	
Fundamental Considerations in the Design of the New Tools .....	252
The New Machine Requirements .....	275
Remodeling an Old Equipment .....	295
Section V. Problems Involved in the Use of High-Speed Steels.	
Statement of the Problem .....	300
Making a Beginning .....	319
Section VI. Appendices.	
A. Analyses of High-Speed and Special Steels .....	330
B. Taylor on Hardening High-Speed Tools .....	332
C. Reference Table for Determining Cutting Speeds .....	334
D. Diagram for Determination of Time of Turning Operations .....	336
E. Summary of Metal Removed and Cost of Removal .....	338
F. Taylor Tables of Practicable Speeds .....	339
Index .....	345



# HIGH-SPEED STEEL.

## CHAPTER I.

### THE DEVELOPMENT AND NATURE OF HIGH-SPEED STEELS.

#### EARLY TOOL STEELS.

**The Earliest Tools.**—That the extraction of iron from its ores was practiced long before historical times, is evidenced by many remains of prehistoric forges and smelters. Not a few implements of that material whose antiquity cannot be doubted, also have been found. Scriptural authority ascribes the first forging of iron to Tubal Cain, whose time is generally fixed at about 38 centuries B. C. Whether or not steel dates back so far as that, it is quite certain that steel implements must have been used not much later, in the construction of certain of the very earliest ancient monuments known to us; for tools of soft iron could not have cut and carved the very hard rocks of which they were constructed. In connection with the building of the pyramids

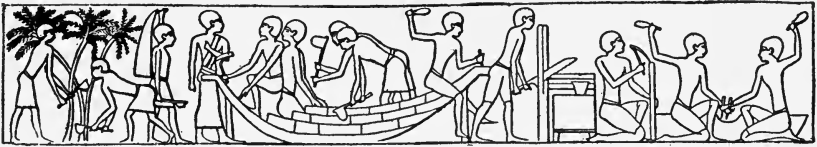

FIG. 1. The monumental carvings of Egypt are conclusive evidence that the ancient Egyptians possessed good steel tools, which alone could have cut the hard stones smoothly. The pictures themselves sometimes, as in this case, indicate the kind of tools in use and the methods of using them.

(date fixed at about three thousand B. C.) Herodotus speaks of the immense sums of money which must have been spent for the "iron" with which the builders worked; and in the Great Pyramid there was found a fragment of an iron tool which must be at least five thousand years old, containing a small percentage of carbon. There is good reason for believing also that the working of steel as well as of iron was known to and practiced by the early Greeks and others, perhaps as far back as ten centuries B. C.

**Ancient Steel Making.**—As to the method making of the common steels of antiquity, little is certainly known. The iron to be converted into steel appears to have been made in a sort of crude catalan forge; and as iron has a strong affinity for carbon, it is probable that in forging iron which had been long in contact with the fuel and therefore

had taken up some carbon, it would be found somewhat harder and stiffer than common iron, and on that account more suitable for tools. Among the very ancient Egyptians, it is said, pieces of meteoric iron were heated in close contact with the fuel and kept at a high temperature, just below the melting point, for a long time. The absorption of carbon was of course sufficient to make a superior iron, or steel, of the piece so treated. The next step in the development of steel no doubt was the accidental dropping into water of a red-hot tool of some kind. The superior hardness and usefulness of such a tool would certainly lead to further experiment and more careful treatment. Whether or not this was the actual course of events in the development of ordinary steel, it is certain the ancients possessed some remarkably good steel implements and knew pretty well how to use them.

The ancient method of working metals was by forging, chiefly. If this did not give a suitable result, or if a sharp cutting edge was required, recourse was had to abrasives. Machinery being practically unknown, it was impossible for primitive men to do much in the way of metal cutting, although indeed it seems that graving or hand cutting of some kind was practised almost if not quite as far back as the time of Tubal Cain. Certain it is that the art was practiced among the Chinese long before the Christian era began.

**Ancient Metal Cutting.**—Not however until the beginning of what has aptly been called the age of machinery, which dates back scarcely



Permission of *The Iron and Steel Magazine*.

FIG. 2. A primitive furnace for smelting iron and producing steel. The ore and fuel lie in the foreground. In charging the furnace, these were carried up the rude steps carved in the hillside against which the furnace was erected.

more than a century, did the real development of metal cutting begin. A crude form of the lathe had been known for a good many centuries, as long ago indeed as the days of Solon, in the sixth century B. C.; but

this improved but little upon the tedious and laborious hand-cutting process. The arrival of steam power made possible the development of relatively heavy and powerful machinery, and permitted the large development of cutting tools.

**Wootz, Damascus and Toledo.**— From the earliest times the quality of steels varied greatly. The celebrated wootz steels of India, and Damascus made at the Syrian city of the same name, and later at Toledo, in Spain, were examples of superior steels susceptible of extraordinary tempering. They both, however, were crucible steels, and the latter is also said to have contained strong traces of tungsten, nickel, manganese, and similar elements important in the new high-speed steels.

**Production of Wootz.**— Wootz is a steel of high quality, the manufacture of which reaches back to very ancient times. Aristotle, the

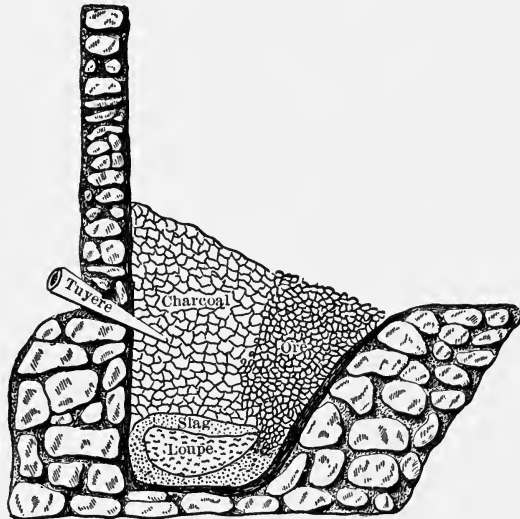

FIG. 3. Section of a crude catalan forge, still to be seen in remote places, in which steel is often made directly from the ore. The charcoal and ore, the latter in small lumps, are charged at the level of the floor or a little above. As the reduction proceeds, a more or less steely lump, the "loupe," collects at the bottom.

Greek philosopher, describes it as nearly as 350 B. C. or thereabouts, and tells us how it was made. Other ancient writers in the subsequent centuries likewise make mention of it. This steel still is (or at any rate until recently was) fabricated by some of the remote mountain peoples in the north of India. The method of manufacture is essentially the same as that described by Aristotle nearly twenty-three centuries ago. First the iron is extracted from the ore in a sort of rude clay catalan forge, perhaps built against the side of a hill. The result is a lump of sponge iron, which is hammered to make it more dense and to rid it of as much of the unmelted ore and cinder as may be. The lump is then broken into smaller pieces, hammered again,

and afterwards placed in a specially prepared small clay crucible, holding about a pound of metal. Along with the iron is put some finely divided wood, and a few green leaves, the latter laid at the top of the charge. The crucibles are luted up and placed in a diminutive furnace of clay, generally a bare two feet in diameter, conical, and sometimes partly below the surface of the ground. The blast is furnished by a pair of skins blowing through a bamboo and clay tuyere.

After several hours the crucible is tested for complete fusion of its contents, by being shaken; and if the melting is complete, the crucible is allowed to cool, to be later broken open. The result, if successful, is a small lump of exceedingly fine, smooth-surfaced steel, which takes a remarkable temper. This steel has been used almost exclusively for swords as far back as tradition runs; and it has been said of Wootz blades, as also of Damascus, that when properly tempered and skillfully handled they would cleave a bar of iron without losing edge. It has been declared also that a blade of wootz has cleanly cut a wisp of silk floss tossed into the air.

**Crucible Steel among the Chinese.**—This product of ancient skill seems to have been little if at all known, as an article of commerce, to those nations who have done most toward the advancement of civilization through the development of the steel and iron-making art. Nor, apparently, was it known to them that steel was produced in eastern Asia contemporaneously with, and as now seems established, long before wootz was made in India. Recent archæological discoveries indicate that a kind of crucible steel was known to and made by the Chinese probably many centuries before the Indian product. The method by which the Chinese steel was produced is not yet known. It probably was something like that practiced in India; the more so since there are indications that both these peoples may have learned the process from a common source, a people living in the plateau between the two lands.

**Manufacture and Nature of Damascus.**—Damascus steel likewise was a crucible steel. It differed from wootz however, and from other steels as well, in one respect. Those familiar with its appearance are aware of the curious veining or figuring seen on the surface. This characteristic, adding greatly to the beauty of a finished surface, is due to thin strips of soft iron alternating with similar strips of steel, and these thoroughly welded, twisted and otherwise completely wrought together. This steel was first made, as far as known, at the ancient Syrian city (said to be the oldest existing city in the world) whence it derives its name, and doubtless also is of great antiquity. The Scriptural reference to "iron from the north," together with other allusions in Scripture and the historical references to the Chalybes (whence is derived the Greek and Latin names for steel) indicate that the region



north of Damascus, if not that city itself, was a renowned center for steel manufacture hundreds of years before the beginning of the Christian era.

**Virtues of Ancient Steels.** — The virtues of Damascus steel were made famous throughout the western world by the crusaders, and its manufacture was at a later period established at Toledo, in Spain. Toledo blades came to have a repute almost as great as those made at Damascus. It is stated that they possessed tempering qualities as remarkable as those of wootz, and that they were sometimes packed in boxes curled up like clock springs of our day.

Whether or not these ancient steels possessed all the remarkable qualities attributed to them, they certainly were marvels of their time; and indeed they remain marvels in our own time. Nothing superior to them, in respect of tempering quality, has been produced by modern methods of steel making. It is certain that all of the steels mentioned were at some time or other used for tools of various sorts, very likely for use in the metal-cutting arts. For the latter purpose, however, they possessed no striking advantage over other steels.

**Variability of Primitive Steels.** — The quality of ancient steels, and of those produced up to a comparatively recent time, varied greatly. Considering the methods of manufacture and the diversity of ores used, this is not surprising. Some ores would contain elements wanting in others; and in the process of forging, or perhaps of extraction, certain tools would be in closer and longer contact with the fuel and would therefore absorb more carbon. Modern manufacturing methods make it possible to eliminate all these uncertainties, and it is comparatively easy to produce continuously steel of practically constant quality.

**Development of Metal Cutting.** — The development of metal cutting was, until a few years ago, brought about almost wholly through the evolution of the machine by which the tool was made to do its work, and scarcely at all through the development of excellence in the tool itself, except in so far as it was found that varying shapes gave varying results. The steel, its nature, and the method of treatment, remained much the same as for centuries before.

With the development of powerful machinery, however, it was soon found that there was a limit to the amount of work to be got from a tool for cutting metal. The tenacity with which the particles of a homogeneous mass of steel, iron, or similar tough metal cohere makes it no slight matter to drive a tool into the mass or force off a portion of it. A small graver in the hand can easily make a scratch in the surface of an iron plate; but to remove a chip say a quarter of an inch by three-quarters, a cut by no means unusual nowadays, involves the consumption of an astonishing amount of power. Now the energy used up in making a cut, is partly, of course, converted into latent energy

stored in the chip with its changed form and changed relation of constituent particles; and partly into sensible heat at and near the cutting point of the tool, which heat is taken up by the tool, the chip, and the piece being machined. The chip being relatively small and continuously changing in respect to the particles of metal at the cutting point, rarely gets so hot as to show a color higher than deep blue, and not often that. The piece machined is relatively large, and readily absorbs and conducts away its portion of the heat, which is a small part only of that generated. The tool, however, is continuously at work, and absorbs a good deal of the heat generated. Now if the tool be worked heavily, which is to say usually if the cutting speed be relatively high, the cutting edge quickly gets so hot as to draw the temper and make the ordinary carbon steel tool useless.

**Endurance Limit of Tools.** — Evidently there is a limit to the amount of work such a tool is capable of doing; and this limit, the snail's pace at which it has heretofore been necessary to carry on metal-cutting operations, has been an anomaly in modern industry the chief characteristics of which are magnitude and speed. There is a vim and vigor about wood-working operations as seen in a modern shop, which is exhilarating. A large spindle, for example, is shaped while revolving at the rate of two or three thousand turns per minute, the rate, of course, depending somewhat upon the size and nature of the wood. A steel shaft of similar diameter revolving against an ordinary tool at a very small fraction of the same number of turns would almost instantly "burn" it.

**Maximum Speed with Carbon Tools.** — Carbon steel, as heretofore used in tools, no matter how well hardened, has not enough toughness and hardness to withstand the rubbing of the chip for any considerable length of time, even when not run fast enough to affect the temper. The tool therefore dulls; and this dulling proceeds in a sort of geometrical ratio as the cutting speed increases, being augmented by the drawing of the temper which accompanies rapid cutting. The speed in all metal-cutting operations has therefore had to be comparatively slow, no matter how powerful might be the machines in use. Thirty feet of chip per minute, as any machinist knows, has been considered rather good work; while fifty feet per minute has been very unusual. Under ordinary circumstances the management of a shop was pretty well satisfied if the machine tools could maintain an average speed of twenty to twenty-five feet per minute.

Such deliberation, necessary though it has been, is depressing in this era. A creeping mass of metal turning leisurely round and round or moving back and forth, as has been customary in the average shop, is quite out of harmony with the modern spirit of expedition and hurry. But while a few dreamed of the possibilities of cutting metal, some time in the future, with something of the vim with which wood can be

cut; and while machines had been developed so tremendously as to leave scarcely anything to be desired in that respect; nevertheless the ultimate limit seemed to have been reached.

But it had not.

**Similarity of Ancient and Modern Steels.** — For at least a thousand years, and probably for several thousand, there had been no single important advance, no one striking development, in the nature and characteristics of steel, in respect to metal-cutting qualities at any rate. The property of becoming hard, possessed in common by all steels, and distinguishing them from ordinary iron, is due to the presence of carbon diffused throughout the mass of the metal. How the presence of the particles of carbon brings about the virtue of hardening is yet a matter of discussion.

**The Modern Science of Steel Making.** — Modern steel making is a fact only because the science of chemistry, itself scarcely a century and a half old, has made it possible to understand that there is an affinity of certain elements for certain others and that under given conditions exactly the same combinations can be expected in chemical compounds and alloys. The prehistoric steel makers had no idea that in firing iron with certain fuels they were carbonizing it, actually forming of the iron and fuel a new substance which contained besides iron the same element which in one form constitutes charcoal, in another graphite, and in a third, diamond. That, however, is exactly what they did.

**Blister and Double Steel.** — The method of the very ancient steel makers, except as already noted, was essentially the same as that commonly in use up to comparatively modern times. The bar to be carbonized was heated in close contact with charcoal or other suitable fuel. In later times this was done in a sort of double muffle furnace, and the cementation or carbonization was more even and complete. Steels thus made however, were found to be only skin deep, so to speak; for since the carbon merely soaked in and combined with the iron nearest to it, evidently the central portion was less completely carbonized than the exterior, and except possibly in very thin bars was generally quite devoid of the hardening element, even after ten or twelve days' treatment. In later times, when the muffle furnace came into use, steel thus made was known as blister steel, from the blisters or scales appearing on its surface during the process of carbonization. This steel is not dense and uniform enough for fine tools. It was known for many centuries, however, that hammering (and later rolling) so as to "work" it thoroughly, greatly improved the quality and usefulness for tool making of such "cementation" steels. An improvement upon this method was that of breaking the bars into lengths, bundling them, and then welding together. The "shear steel" thus produced was of much better texture and uniformity, but was not so good as the "double" or "double shear" steel which was made by repeating the process a

second time. Damascus seems to have been made somewhat in this fashion, but after the desired uniformity had been obtained in the steel itself, thin layers of the steel and of fine iron seem to have been again welded together. The grainy or "watered" appearance of Damascus is said to be due to this streaking with iron.

**Revival of the Crucible Method.**— "Shear" or "double" steel was of course a great deal better adapted to edge tools than any produced by the earlier methods; but it still had the disadvantage of being more or less streaked and spotted, for no amount of hammering or rolling could entirely eliminate the inequalities of carbonization by the cementation process. It was not until about the middle of the eighteenth century that a method of overcoming this defect was discovered. About that time one, Huntsman, was astonishing other makers of blister steel by the absolutely uniform texture of his steel. It lacked the "seams" or streaks characteristic of the other steels of that day, and hardened uniformly all the way through. Keeping a process or method secret was at that time considered the only way of distancing competitors, and Huntsman and his workmen managed to keep their trade secret to themselves until the envy of a competitor, so the story runs, imposed upon their humanity and learned the secret. On pretense of seeking shelter one stormy night this competitor, according to the tradition, appeared at the forge where the wonderful steel was made, and was at last admitted for humanity's sake. What his expectant but astonished eyes beheld was so absurdly simple that he may well have wondered why he and others had not thought of it also. It was in fact nothing but the melting of the broken pieces of blister steel in a crucible. Of course the steel made in such a way would be uniform, for each crucible, at any rate. Had the spy but known it, however, he beheld a process which in its essential features was centuries old; for as the reader has already seen, crucible steel has been known in some parts of the world since time immemorial.

**Later Methods.**— Steel made by Huntsman's method came to be known as "crucible" or "cast" steel. The first name is still considered a sort of trade-mark for steel made in this way, though there are many other steels nowadays made in pots or crucibles and in one sense therefore entitled to be so called. This crucible steel at once came into favor and held its position as the tool steel par excellence until the introduction of mushet steel and the subsequent development of the Taylor-White process. The result of these advances was something essentially different and in every way superior for most, if not indeed for all, tools used in the metal-cutting arts, and perhaps also for all cutting purposes. The only important change in manufacturing crucible steel was made by the elder Mushet about the beginning of the last century. Instead of melting blister steel in the crucible, he used refined iron

(scrap or bar) mixed with some carbonaceous compound. The soft iron was thus carbonized in about the same way as the sponge iron in making wootz. Steel produced in this way, however, had not the excellence of that made in India; nor even of the blister-crucible steel of Huntsman. Some fairly good steel is thus made, but usually it needs to be thoroughly "worked" to make it dense and good enough for fine tools. Later Mushet mixed pig-iron with the contents of the crucible; and this is still usually done except when the blister-crucible steel is required.

A peculiarity of crucible steel is that it must be "dead-melted" or else it is liable to be more or less porous and otherwise imperfect. This consists merely in allowing the melted steel to remain fluid in the crucible for a half hour or more, before pouring.

**Open Hearth Steel.**—Many attempts have been made to produce as good a steel by other methods, whereby the cementation process could

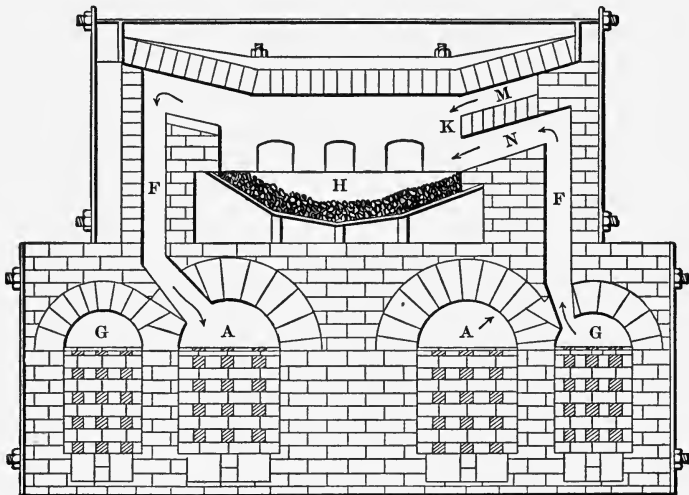

FIG. 4. Longitudinal section through a Siemens regenerative open hearth furnace. To start the furnace a wood fire is burned in the two chambers at one end of the furnace (*G* and *A*). When these are red hot, a current of air is passed through the brick checkerwork in *A*, and up a flue to *M*; a current of fuel gas is passed through the checkerwork in *G*, and up a flue to *N*. The gas and air, thus preheated, meet at *K* and fill the furnace chamber with a hot flame, which radiates its heat to the metal on the hearth *H*. The hot gases then pass down to chambers *A* and *G* on the opposite end of the furnace, and store their waste heat in the brick checkerwork there. At intervals of 15 to 20 minutes, the currents of air and gas are reversed in direction, and enter the furnace through the alternate pair of regenerative chambers, taking from them the stored-up heat to create a still more intense flame over the hearth.

be avoided. There have been, and still are, many forms of open hearth furnaces which produce a fair quality of steel direct from pig or from refined iron; and the bessemer process has been greatly improved and modified in so far as results are concerned. But neither of these type processes produces a satisfactory tool steel, though some very good results have been secured from certain carefully made open-hearth steels.

In the open hearth furnace (Fig. 4) from five to nearly one hundred tons of steel can be made at a heat, whereas the crucible process makes but fifty to one hundred pounds per pot. Essentially the open hearth process consists in remelting old steel scrap and mixing with it pig iron, which is either melted at the same time or else brought in the still liquid condition from the blast furnace in which it is made. The proportion of pig iron will vary all the way from ten to nearly one hundred per cent, depending on the state of the market, the quality of steel to be made, and other like conditions. Pig iron is an impure iron containing three to four per cent of carbon, one to two per cent or more of silicon, sometimes phosphorus, manganese and other impurities. The impurities are diluted by the mixture of steel scrap, and are further reduced through oxidation by iron ores added to the furnace charge for the purpose. When the bath is purified to the desired point, manganese and a little silicon are added to rid it of dissolved oxygen.

Open hearth steel is used in immense quantities in machinery and structural work, but makes tools inferior to those of crucible steel.<sup>1</sup> The heats are large, which necessitates pouring them into large-sized ingots, and these are softer and inferior in the center after cooling. The manganese added to cure the superoxidation is not a perfect antidote, and it is impossible to prevent imperfections in steel made in this way, or to obtain such a uniformity of hardness as is required for the best tools.

**Bessemer Steel.** — In the Bessemer process, liquid pig iron is brought from the blast furnace and poured into the converter (see Fig. 5). The

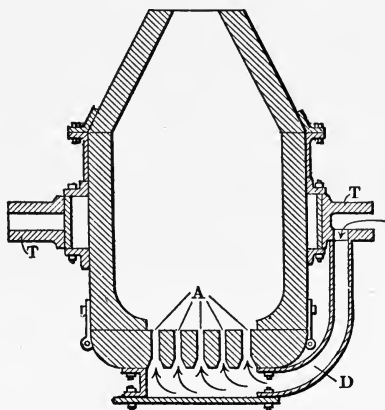

Fig. 5. Section of a bessemer converter. Silicon, manganese and carbon are removed from the molten pig iron by blowing air through it. The converter is mounted on trunnions, *T*, one of which is so made that a blast of air passes through it and along a duct, *D*, to the bottom, whence it comes up through openings, *A*, in the bottom. When the metal is judged to be in proper condition, the converter is rotated on the trunnions and the charge emptied.

<sup>1</sup> That is, inferior to crucible steel made in the manner described, for steels have been put upon the market under that name which are quite inferior. Though possibly they have been melted in a crucible, the name is misleading, and usually is intended to be so.

carbon and silicon in the metal are then burned out by blowing a spray of cold air bubbles through the molten bath.. This combustion supplies the heat which not only keeps the metal liquid, but even raises its temperature some hundreds of degrees, and white hot flame pours from the



FIG. 6. The bessemer converter in action.

mouth of the converter during the ten minutes or so while the purification proceeds. After practically all of the carbon and silicon are removed, the predetermined dose of melted iron rich in carbon, manganese and silicon (known as the "re carburizer") is poured into the converter to rid the metal of superoxidation and give it the desired grade of carbon, and it is then cast into ingots.

Bessemer steel is still more liable to irregularities and imperfections than open hearth, and is unsuitable for good grades of tool steels.

**Electric Steel.**—The production of steel in the electric furnace is the only other important process in use today, and by this means electrical energy is substituted for fuel in producing the necessary heat. The metal is entirely protected from oxidation in this process and is capable of a purification unattainable by any of the others. The steel is said to be superior even to crucible steel, and to be made at a less cost.



## CHAPTER II.

### SELF-HARDENING<sup>1</sup> AND HIGH-SPEED STEELS.

**Manganese-Bessemer.**—The addition of manganese to the contents of the bessemer converter made it possible to work the steel freely while hot and helped give bessemer steel its well known properties. It was Robert F. Mushet, himself interested in steel manufacture, who suggested the addition of manganese in the making of bessemer. He did not stop with the results his suggestion quickly brought about, but continued making experiments for the improvement of ordinary steels. He had at this time no idea of improving steels for use in tools, particularly; but was working primarily to get the best possible steel for ordinary use. While carrying on these experiments, however, he made a discovery of far-reaching importance to all those industries in which metal cutting is practiced.

He discovered self-hardening steel.

**Discovery of Mushet Steel.**—Ordinary steel, owing its hardening property to the presence of carbon, has been hardened from time immemorial by quenching in water while at a red heat, as is well known. If allowed to cool slowly, as in the air, it is too soft for use in tools. During the course of his experiments, sometime in 1868, Mushet found that one of his bars seemed to have the property of becoming hard after heating, without the usual quenching. This circumstance was not merely singular; it was astonishing, and contrary to all previous experience. Possibly it marked a new epoch in steel making. Analysis of the bar behaving so singularly showed that it contained a percentage of tungsten.

**Properties of Tungsten Steels.**—Not only did the bar containing tungsten harden without the customary quenching, but it was actually harder than ordinary steel which had been quenched. It occurred to Mushet that this extraordinary circumstance might be turned to advantage in the production of superior tool steel, and he accordingly set himself to developing tungsten steel with this end in view. The result of experimenting with hundreds of metal mixtures in the crucible was a

<sup>1</sup> Mushet steels soon came to be known in England as "self-hardening." After a time the term "air-hardening" was used more or less in the United States along with "self-hardening." In this book the term "self-hardening" will be used to refer to mushet steel, though of course high-speed steels also are partially self-hard. On the continent high-speed steels are frequently known as "rapid steels."

steel alloy much more satisfactory than any other then in use, which possessed the property of becoming very hard by mere exposure to the air.

**Improvements in Air-Quenching Steels.**—It was not until after the steel had come into somewhat general use that it was discovered by Mr. Henry Gladwin, then associated with Mr. Mushet at the Clyde Steel Works, Sheffield; and by several other engineers almost at the same time, that still better results could be obtained if the cutting portion were reheated and then cooled in an air blast. This discovery, in Mr. Gladwin's case, at any rate, was the result of laying some bars of mushet steel on the earth floor of a smithy, near the door. A draft swept over the cooling bars, and they were later found to be superior to bars cooled where there was no draft. Later experiments showed that cooling in an air blast was still better; and that further improvement in the quality of tools could be made by bringing the color to a full scaling or almost yellow heat during the re-heating. This, however, was not usually done by toolsmiths, and in consequence most users failed to work mushet tools at their highest efficiency.

**Mushet Steel in Engineering.**—The new steel was immediately put upon the market under the name "R. Mushet's Special Steel." The company organized for its manufacture and sale, however, did not succeed well in business; and some three years later the production of mushet steel was taken over by Samuel Osborn & Co., Ltd., at the Clyde Works, Sheffield. The wide introduction of the new steel into engineering works, and its imitation under the name of air- or self-hardening steel quickly followed.

A substantial advance had been made in the art of cutting metals. It was possible to turn and plane (at first the use of mushet steel was limited to these operations) at double or triple the former speeds; and to machine pieces formerly quite too hard for the tools available or so hard as to make the cost of operation prohibitive. Even after their general use in engineering works, mushet tools were but little used for increasing speeds—most usually only to save frequent grindings or to permit doing jobs previously impossible.

It was not until a full quarter century after mushet or self-hardening steel had become an established fact in engineering that the marvelous, and in the light of all previous experience paradoxical, properties latent in it were clearly appreciated, and the industrial world caught a glimpse of what promised to be a revolution in machine shop methods.

**The Taylor-White Investigations.**—The discovery of the possibilities in tungsten steel, like that of the nature of the steel itself, was fortuitous, if indeed not accidental. In both cases the circumstances that led to the discovery were quite undesigned, and the discovery merely incidental to something else. As far back as 1894 Mr. Fred W.

Taylor began experimenting with mushet and other self-hardening steels with a view to determining which was best suited to special kinds of work. This was but a single feature of his program of improving shop efficiency and of determining a logical system of shop management. Shortly after taking charge of the Bethlehem works in 1898 he associated with himself Mr. Maunsel White and others, for better prosecuting the work in hand. After careful tests had been carried on for a time it was decided that a certain make of steel, with proper heating in the tempering process, could be run at higher speed than any of the others; and it was thereupon decided to adopt this make for exclusive use in the shops.

In order to demonstrate their superior efficiency to all the foremen and thus be sure of hearty co-operation in making a change of so great magnitude as was involved in changing a large proportion of the tools then in use, a number of tools of various kinds of steel were ordered carefully dressed, tempered, and ground to exactly the same shape. The foremen were then assembled to witness the comparative performances of the tools. To the astonishment, and we may well believe chagrin, of the demonstrators, the tools made of the selected steel failed to make a good showing. In fact they proved to be inferior to any others in the lot. That is, they could not be worked at as high a speed.

Very naturally so unexpected a circumstance would arouse the curiosity and interest of such keen investigators as were Taylor and White. It had to be accounted for; and so another investigation was set on foot.

The range of heating, in the case of carbon steel tools, as is well understood, is rather narrow. Air-hardening steels have a still narrower but higher range; and the excellence of a tool depends upon the care exercised in heating it to just the necessary temperature when "drawing" or tempering. The first thought that occurred to Taylor and his assistants naturally was that the heat treatment of the tools which failed had been faulty; that very likely they had been under-heated. Whether this was so, or not, seems not to have been definitely determined. One thing however, was determined; namely, that a series of experiments should be undertaken to find out just what would be the effects of various degrees of heating, ranging all the way from a black to temperatures considerably beyond what had been previously thought permissible.

**The High Heat Treatment.** — The results of the experiments were startling indeed. When the investigators were in the midst of the work laid out, it was realized that they had made a discovery which upset all previous beliefs as to the effects of heat upon steel, and which was apparently bound to bring about ultimately a revolution in machine shop practice. It was nothing less, indeed, than that steels of the tungsten class instead of being ruined by high heats, were actually

improved so greatly that cutting speeds became possible which previously had been only dreamed of; the discovery, in fact, of the high-speed qualities inherent in these alloy steels when subjected to the super heat treatment.

Nothing surprising was noticed until tools were heated considerably higher than had been customary, so high indeed that in the light of all experience the treatment was ruinous. Tools thus superheated were not ruined, but on the contrary stood up to their work better than those given the usual treatment; and apparently the higher the heat treatment, the better the tool. For unnumbered centuries it had been believed that steel must not be heated beyond a red; but here were tools which not only were not ruined, but which got better the higher they were heated. The heating, it was found, could actually be carried up to the melting point; and a tool so treated would cut more metal and do it more rapidly than one not raised to so high a temperature.

The deterioration of tools which had been heated to near 875 degrees C. (1600 F.) was not surprising; for it was previously well understood

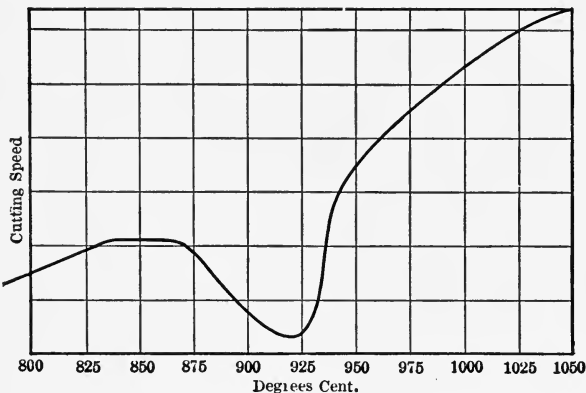

FIG. 7. Curve showing the influence of the high heat treatment on tungsten steels.

that all steels were damaged by being heated so high as this — though indeed, Mushet recommended heating his air-hardening steel to a full scaling or almost yellow heat, which is not far from 1200 degrees C. (2200 F.). This deterioration is shown in Figure 7, which indicates the relative cutting speed possible with mushet steel when heated to temperatures varying from 800 to 1050 degrees C. (1450 to 1900 F.). The surprise came when the tools were heated to beyond 925 degrees C. (1700 F.), for with each very slight increase of temperature used in hardening, the cutting power was increased to an extraordinary extent.

**Improving Air-Hardening Steel.** — Tools of this sort were not, however, wholly satisfactory. The cut was rough, and it was by no means certain that the alloy used was the best for this sort of treatment. The

discoverers, not satisfied with the results already attained, began to investigate the effect of varying the proportions of the alloy and of the introduction of other elements. The outcome of a large number of trial mixtures was a steel capable of doing from three to six times as much work as had previously been possible, and which required for the development of its greatest efficiency a heat treatment which would utterly ruin ordinary steels.

True, it has been pointed out that tungsten and other hardening elements besides carbon were present in some steels of very ancient manufacture, and the tungsten-chromium-manganese steels with which these experiments were carried on had been known for some years. The method of high-heat treatment nevertheless was certainly new, though it would seem that the Mushet experiments and recommended practice, if they did not quite anticipate the Taylor discoveries, approached very close to them. Even if it had been known, the combinations of alloys in the ancient steels referred to were quite incapable of developing the powers which modern high-speed steels acquire through the high-heat process, and the old mushet steels needed modifying and improving to adapt them in the highest degree to the new method of treatment.

**Rivalry in Experimentation.** — For some time the discoverers managed to keep their process to themselves and to the shops to which they sold the rights; but a discovery of such far-reaching importance was bound to become known. Indeed they had no intention of keeping it secret except as a means whereby they might be enabled to carry on further investigations. As soon as the nature of the new steel and the processes of treating them became generally known to the technical and engineering world, and the possibilities of high-speed cutting were in some degree apprehended, manufacturers of tool steel on both continents at once began to vie with one another in their efforts still further to perfect the tungsten steels and to enlarge the range of their usefulness. In the aggregate an immense amount of money has been spent in experimentation with a great variety of mixtures and methods of manufacture. One manufacturer alone tried over two hundred different mixtures and another worked some four years before the product was thought satisfactory. Others have no doubt carried on experiments on a scale equally large, and possibly larger. At the time of this writing (1909) there are perhaps a hundred different brands of high-speed steel upon the market, and new brands of the so-called "new," "improved," or "superior" high-speed steels are multiplying at a rate which bids fair to double the number within a short time.

**Faults of Early High-Speed Steels.** — The first high-speed steels, though of astonishing cutting and wearing qualities, were not adapted to finishing and other fine work. Their coarse, granular structure,

perhaps, did not take a cutting edge such as would leave a good finish; and so the new tools were used mostly for coarse and heavy work. This defect has been, in some if not in all brands, completely overcome; and high-speed tools are now in use not only for the finest grades of metal cutting, but for wood cutting, which certainly is an extreme test of the smoothness of a cutting edge. It may be thought strange that high-speed steel should be used in a wood shop, where speeds have for a long time been as high as is expedient and safe. There is no particular gain in speed in wood cutting. The advantage in putting high-speed steel tools to this use lies almost wholly in their superior wearing quality. The immediate first cost usually is greater, but the life is incomparably longer, while the cost of maintenance is trifling. This of course is important where many such tools are used.

**Marvels of the New Tools.**—The thing in the way of running ordinary tools at high speed when working on metals has already been shown to be the overheating of the tool near the cutting edge, and the consequent drawing of its temper, which is of course quickly followed by the rubbing away of the edge and the ruin of the tool. This series of steps follows as a result of the friction of the chip bending and sliding over the tool. The high-speed steels are not, within certain limits, thus affected. Indeed, they seem almost to require abuse in order to bring out their highest capabilities. It is a common experience in shops that tools of these steels will not work to the best advantage until they have been run a little while and “warmed up.” The speed capabilities and cutting power of these tools are indeed marvelous, compared with former experience. Thirty feet of chip per minute is a good performance with carbon tools; and the average on such work is not likely to be much over twenty, in a well-regulated shop. A hundred feet per minute has been mentioned as the extreme record of carbon-steel tools; and under ordinary conditions rarely is it possible to attain fifty feet continuously. But high-speed tools in more than one shop cut a hundred and fifty feet and more as a regular performance, and higher speeds still are not at all unusual. Though this is several times as fast as was formerly possible, and is perhaps about twice the average in ordinary shop practice with the new tools, it is by no means the limit. It has been demonstrated that such tools can be worked up to more than three hundred feet per minute; and it is claimed that a speed of four hundred feet has been maintained continuously in cutting carbon steel with a comparatively small cut ( $\frac{1}{8}$  inch) and a slight feed. Mr. J. M. Gledhill, a well-known authority on the subject, has asserted (Proceedings of the Iron and Steel Institute, New York meeting, October, 1904) that five hundred feet is attainable.

At the Paris exposition of 1900, where high-speed tools were first publicly demonstrated, there was shown a lathe tool working for con-

siderable periods at a speed so great that the nose of the tool was red much of the time. In present regular practice tools are not permitted to get red hot, for softening to some degree inevitably takes place and the edge does not hold up. The chips as well as the tools of course get hot; and the former often come off with a deep-blue color when cut at a very high speed.

**The Chip Problem.** — The removal of steel chips, when coming off so fast, is in itself a problem. In one test the services of two laborers were required to keep the machine clear. The total amount of metal removed in the case of some very large machines built with the purpose of utilizing the new tools to their limit, is prodigious. Obviously there is nothing but disadvantage in removing metal unnecessarily; but there are cases where heavy cuts are unavoidable, and even economical. Under these circumstances it is not uncommon for cuttings to be removed at the rate of two thousand pounds per hour. Nor is this by any means the limit. There are recorded tests where double this rate has been attained for short periods. In actual everyday practice it is not unusual for a tool to cut several hundred pounds of chips per day, and that too without having to be ground more than once or twice.

**Inadequacy of Old Machine Types.** — The pressure exerted in taking heavy cuts and the power required to drive machines at the high speed demanded by the new tools are tremendous. In a test, already mentioned, the stress upon the tool was in excess of one hundred tons. To resist such forces and to hold the tool and work firmly in proper relation, ordinary machines are quite inadequate. Machines a few years ago considered paragons of efficiency are, since the advent of the new steels, able to utilize but a fraction of the total efficiency of the tool; and while there is usually considerable advantage in the use of the new tools, it is only by using extremely heavy and rigid machines of the newer type that the full advantage is to be secured.

**Revolution in Machine Shop Practice.** — Revolutions do not occur in a day, especially in the industrial world. There have been great industrial changes, several of them indeed, within the hundred and some years since handiwork ceased to be the chief agency in production. But these changes have been rather in the nature of evolutions. A new discovery or method gradually made itself necessary, and after a time there was a new order of things in which the former methods, once the standard of efficiency, became antiquated and had to be abandoned. High-speed steel evidently is one of those discoveries which will eventually bring about a new régime in the metal-working industries. And while there is small likelihood that things will be very quickly upset, the carbon-steel tool made obsolete and the machine of yesterday's design antiquated, it now appears certain that after a few years carbon-steel tools will have a small place anywhere. Even razors are now

sometimes made of high-speed steel and are said to hold an edge better than carbon steel.

It is true that the new steels are as yet little known in many shops, especially the smaller ones, and that they are used very stingily in many large ones. The high cost seems to deter many from using them, and perhaps also in some cases the failure of first trials made without a satisfactory knowledge of how to make or use the new tools. Tungsten, molybdenum, and other like steel-hardening metals are rare, and consequently expensive, costing as high as \$7 a pound in some cases. The manufacture of high-speed steel likewise is a more expensive process than that of making carbon steel. Of course for high-class tools crucible steel has been generally used; and crucible steel costs more to make than that produced by other processes. But even so, crucible steels sell as low as five cents, and occasionally even less, per pound; though the better grades, those most commonly used in tool making, sell anywhere from ten to twenty cents a pound, according to the grade; whereas ordinary high-speed steels sell for sixty to seventy-five cents per pound, and the "improved" steels run considerably higher in price.

**Efficiency of High-Speed Tools.**— Eventually, no doubt, as processes are simplified, the cost will be much lower. Even at the present high cost, however, considering what it is capable of doing, high-speed steel is usually cheaper in the end. It has been a not uncommon experience that the cost of machine work on particular parts has been reduced one-half or more, though of course this could not be possible in many cases. If so, the industrial revolution in the metal trades undoubtedly would not only be at hand, but quickly accomplished. If the time required for cutting were all that entered into jobs of this sort, of course the cost reduction would be in proportion to the cutting speed. But every user of tools knows that often more time is required to get ready for a piece of work than for doing it. Frequently, indeed, the cutting time is an insignificant fraction of the total required; and obviously in such cases small economy of time could be expected. Nevertheless it is a rare case in which the tool-maintenance account is not capable of being reduced to a greater extent than the first cost is increased.

Contrary to the general belief, the greatest saving effected by the use of high-speed steel ordinarily is not in the cutting of hard materials. The economy here is great, in general; but upon soft material it is practically double what it is in the case of hard material.

**The Modern Way of Making Discoveries.**— Many, perhaps most, of the important discoveries which have made civilization what it is were accidental, or at any rate not designed. Fortuity nowadays however plays a relatively unimportant part in discovery and invention. Even though an important idea be stumbled upon undesignedly, its perfection into a useful invention usually involves painstaking development. Men



conceive problems and set themselves earnestly to their solution, calling to their aid all available previous experience and knowledge in science or whatever may have bearing upon the problem in hand. It does not follow that the problem is always satisfactorily solved. Likewise it not infrequently happens that an investigation started to get at one thing, eventuates in something else not closely related. At some point in the development there may be indications pointing to divergent or even very different lines of investigation, which if carried on intelligently lead to results possibly more important than those first sought. Something like this was the development of the high-heat treatment of tungsten steels.

The problem to which Mr. Taylor had set himself some twenty years before his most important discovery, was the development of a rational system of shop management — one that would obtain the highest possible efficiency in men and machines. Naturally, good tools, the best that could be made, were essential to such a system; and experimentation along this collateral line came to be perhaps the most important of all. In the pursuit of these investigations and the development of high-speed steel a very large amount of money was spent, many mistakes were made, and infinite patience was exercised. Something like fifty thousand recorded tests were made besides a great number not recorded, and close to a million pounds of steel and iron were cut into chips, the total expense having been estimated as not far from \$200,000.

Since the tungsten steels and their peculiar treatment have become generally known to the industrial world, and others have undertaken to experiment with them, probably much more has been spent in their further development. And still high-speed steel is but in its infancy. Like other inventions, it will undergo a process of evolution, one so complete, let it be hoped, as to leave little to be desired in respect of its utility. There is undoubtedly still plenty of room for painstaking and patient investigation and experimentation. In spite of all which, however, high-speed steel has already had a marked influence upon production, so that no shop can be said to be up-to-date which ignores its possibilities.

## CHAPTER III.

### NATURE AND CHARACTERISTICS OF THE NEW STEELS.

**Alloy Steels.**—Until comparatively recent times the name steel was given by general consent to such a combination of iron and carbon (as we now know), together usually with slight proportions of certain other substances, as possessed the qualities of high tensile strength, homogeneity, toughness, and ability to resist crumbling, and which when treated in a particular way became considerably hardened. Later the distinction between steel and some varieties of iron became so slight that now it is very difficult to make a definition which will include, even in the case of the carbon steels, all those iron alloys commonly designated steel, and which at the same time will exclude those of practically identical composition, though perhaps of different structure, which are admittedly *not* steel. It is, in fact, impossible to draw a sharp line between mild steel, produced in an open-hearth furnace, and iron made by the puddling or other process, except for the presence of slag in puddle iron. The latter not infrequently has a higher carbon content than the mild steel. Before the development of the modern processes, it was comparatively easy to decide whether a given sample was steel or iron. If it hardened on being quenched in water after having been heated to a good red, it was plainly steel. But mild steel, with its low content of carbon, does not harden any more than wrought iron does. With the advent of the newer steels still greater difficulties are in the way of a suitable and precise definition, and it would be hazardous to venture one here. It is sufficient for our purpose to take for granted that the name steel may properly be applied to any alloy of iron with carbon, or of iron and carbon in combination with other of the so-called hardening elements, which permits hardening and tempering in a way to combine a relatively high tensile strength, reluctance to fracture, and resistance to crumbling.

**Nomenclature.**—Since the discovery that substances other than carbon in virtue of their presence give iron the quality of becoming hard and tough under certain treatment, or at any rate assist carbon in producing this result, it has become necessary to make distinctions between the various kinds of steels, and it is now customary to speak of them in a general way as carbon, mushet or air-hardening, and high-speed or rapid steels. Various other terms have been suggested, but have not

come into general use, though the term alloy steel is frequently used to designate all other steels than those depending upon carbon chiefly for their specific qualities. The alloy steels in turn are frequently designated as vanadium steel, tungsten steel, and the like, according to the distinguishing alloy; and because tungsten was the first and still is the most common of the elements used in the alloy steels, they are often spoken of as tungsten steels even though that element be in particular cases of minor importance or quite absent. The several alloy steels are used for various purposes to which their individual characteristics particularly fit them. Nickel steel, for instance, is largely used for armor plates and projectiles, and chrome and vanadium steels are largely used for the structural parts of machinery subjected to great strains, as in the case of certain automobile parts. It is not with this use of alloy steels, however, that we are at present concerned.

**Composition of Ordinary Steels.**—Ordinary carbon steel, such as has through the ages been used for tools, contains small proportions of elements other than iron and carbon. Some of these are useful and perhaps even necessary to make the steel easily workable, either in forging or melting. This is the case of silicon and manganese. Both tend to make steel sound by preventing the formation of blowholes. Silicon, in the quantities usually present in tool steels, has small, if any, effect upon the tool; though in steels for some other purposes, where the proportion of silicon may be larger, it causes stiffness and possibly also adds to the hardness. When present in excess of say three or four per cent it causes brittleness and red shortness. Manganese acts as a sort of antidote for sulphur, phosphorus, and perhaps other impurities found in steel. It tends to prevent red shortness, promotes the formation of fine and uniform crystallization, increases fluidity when the steel is melted, and makes it easy to work under the hammer or in rolls. Excess of manganese, however, makes steel cold short and causes surface cracking, especially upon quenching. Certain other elements, however, as phosphorus and sulphur, are not only useless but distinctly harmful; and the greater the proportion of either present, the more inferior the steel. Sulphur tends to make steel "red short" (brittle at a red heat) and therefore difficult to forge; while phosphorus tends to make it "cold short," and therefore brittle when cold. A very minute proportion of either will make a steel worthless for tools of almost any sort. Steel for cutting tools is usually expected to contain less than 0.02 per cent of either, though in some mushet or air-hardening steel the sulphur and phosphorus content have each been found to exceed 0.05 per cent. In extra special grades both sulphur and phosphorus are kept below 0.008 per cent. The following table, giving the percentages of the various constituents of crucible steel intended for

tools, indicates approximately the degree of purity required and the amount of carbon desirable in steel for the several purposes named.

TABLE I.

Use.	Iron.	Man- ganese.	Sili- con.	Sul- phur.	Phos- phorus.	Carbon.
Hammers and other battering tools	99.040	0.21	0.21	0.022	0.020	0.50 to 0.75
Knives and shears, hot cutting	98.935	0.20	0.18	0.020	0.015	0.65 to 0.80
Drills, reamers, dies, etc.	98.731	0.18	0.21	0.015	0.014	0.85 to 1.30
Lathe tools, knives, chisels, etc.	98.520	0.26	0.20	0.010	0.010	1.00 to 1.30
Razor steel.	98.265	0.22	0.20	0.006	0.009	1.30 to 1.50
Graving tools, etc.	98.374	0.16	0.14	0.014	0.012	1.30 to 1.50

**Variations in Composition.**—Of course the content of the various elements is not definitely established for tools intended for any particular use. The practice of different steel makers varies, as also do the requirements of users, with respect to the composition of steels for special purposes. The above table therefore serves mainly to give some idea of the practical applications of the varying proportions of carbon and other elements. It will be seen that ordinary carbon tool steels, speaking in a general way, are constituted of iron, very small proportions of silicon and manganese in combination with carbon ranging from 0.5 per cent to 1.5 per cent, and minute quantities of impurities such as phosphorus and sulphur. The variations possible in the carbon content of tools is well illustrated in the analyses of three well-known brands of carbon steel in use for lathe tools, whose performances were practically identical. The figures are quoted in part from Taylor. It is seen that the percentage of carbon varies from 0.681 to 1.240.

TABLE II.

Steel.	Iron.	Manga- nese.	Silicon.	Sulphur.	Phosphorus.	Carbon.	Tungsten.
III and Z	98.524	0.189	0.206	0.017	0.017	1.047	
II	98.350	0.156	0.232	0.006	0.016	1.240	0.079
S	98.867	0.198	0.219	0.011	0.024	0.681	

**Constituents of Self-Hardening Steels.**—Besides carbon, manganese and silicon, self-hardening steel contains a considerable proportion of tungsten, chromium, molybdenum, vanadium, or certain other like elements, generally, in definite combinations, as hereafter mentioned. The silicon content is practically the same as in carbon steel, while the manganese is usually considerably higher, varying from rather more than one per cent to above three per cent according as the tungsten is high or low. High carbon also has been the rule in these steels, the percentage running say from somewhat more than one, to two per cent, and even higher, although the present tendency is toward reducing the carbon content

in high-speed steels, and it is occasionally found very much lower than one per cent. Chromium, when present, takes the place of a portion of the manganese or the tungsten, which latter ranges from about 4 to 11 or 12 per cent. The analyses here given are characteristics of these steels.

TABLE III.

Steel.	Carbon.	Tungsten.	Molybde- num.	Chromium.	Manga- nese.	Silicon.	Sul- phur.	Phos- phorus.
Mushet	2.150	5.441		0.398	1.578	1.044		
Midvale	1.140	7.723		1.830	0.180	0.246		
B	1.615		4.580	3.430	1.650	0.285	0.016	0.027
C	1.750	10.000		1.000	1.750	0.060		
D	1.842	11.589		2.694	2.430	0.890	0.007	0.023
E	1.220	7.020		0.078	0.300	0.180	0.010	0.017

**A Singular Anomaly.**—From the fact of its containing rather more than 7 per cent of tungsten, the steel marked E would naturally be thought self-hardening, like the others. This however is not the case. Though it has a tungsten content about a half greater than that of some self-hardening steels, this steel has no such property, when heated to the customary temperatures, at any rate. It hardens only on being quenched in water, as is the case with ordinary carbon steel. This circumstance naturally raises the question as to what causes tungsten steel to be self-hard, and likewise that of why steel of any kind becomes hard under certain conditions.

**Theory of Steel Hardening.**—The hardening of ordinary carbon steel, as is very well known, is accomplished by heating the piece intended to be hardened to a red color ranging between a dark and bright cherry (something like 735 degrees C. or 1350 F.), and then quenching it in a water or other suitable bath to about the normal temperature of the air. This process seems to change entirely the structure of the steel as seen under the microscope. Careful investigations into the nature of these changes have been made, and a number of theories or hypotheses have been advanced to account for, or rather to explain them. The several hypotheses differ more or less among themselves; but those that are most generally received agree substantially that steel may exist, according to temperature or quenching temperature, in three type forms. At temperatures below 735 degrees C. or thereabouts, carbon steel is in the unhardened or annealed state. Between 735 degrees C. (1350 F.) and 820 degrees C. (1510 F.) it exists in a hardened state; and above 820 degrees C. it exists in a state harder than the first and softer than the second, and is at the same time very tough.

**The Constitution of Annealed Steel.**—Steel is not a simple substance but, as shown by the microscope, is a conglomerate of crystals of dif-

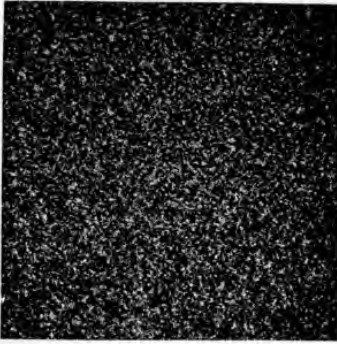

FIG. 8. Typical structure of annealed steels.  $\times 150$ .

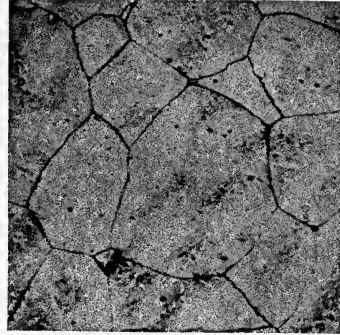

FIG. 9. Structure of hardened high-speed steel.  $\times 1,000$ .

From Mr. C. A. Edwards' paper on "The Function of Chromium and Tungsten in High-Speed Steel," in the *Journal of the Iron & Steel Institute*.

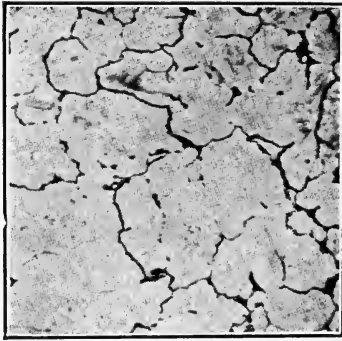

FIG. 10. Microscopic structure of high-speed steel ingot as cast.  $\times 150$ .



FIG. 11. Microscopic structure of high-speed steel ingot as cast.  $\times 1,000$ .

From Dr. Carpenter's "Possible Methods of Improving Modern High-speed Turning Tools."

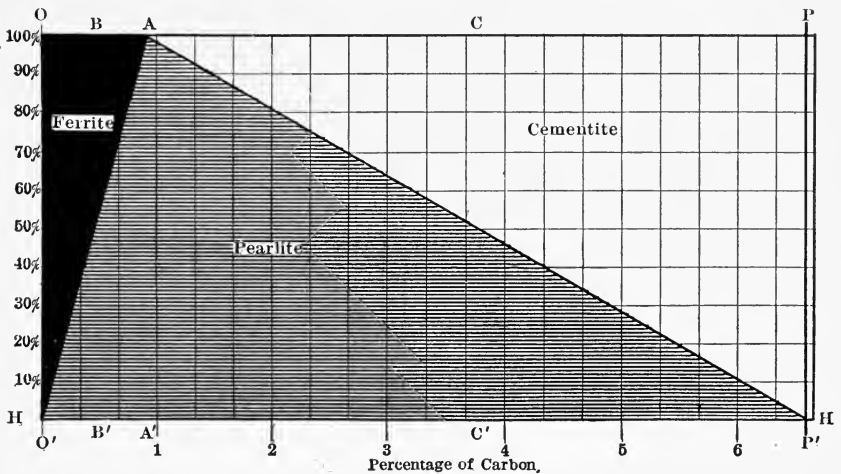

FIG. 12. Constituents of annealed carbon steels.

ferent substances. For example, annealed steel containing 0.90 per cent carbon, consists entirely of crystals having a pearly appearance under the microscope, to which the name of pearlite has been given; while in steel of less than 0.90 per cent carbon the microscope shows pearlite with varying amounts of a substance called ferrite, the proportion of which increases as the amount of carbon decreases from 0.90 per cent. Steel of more than 0.90 per cent carbon consists of pearlite again with varying amounts of silvery white crystals of cementite. The properties of a steel depend upon the properties of pearlite, ferrite and cementite, and upon the proportions in which these substances exist in it.

**Graphical Illustration.**—The amount of pearlite, ferrite or cementite in different compounds of iron and carbon is shown graphically in Fig. 12, in which the distance from the axis  $OO'$  will represent the amount of carbon in the material, and the vertical distance above the axis  $HH'$  in the different areas there shown, will represent the percentages of pearlite, ferrite, or cementite present. For example, a line drawn from  $A$  to  $A'$ , which is at a distance from axis  $OO'$  corresponding to 0.90 per cent carbon, will be entirely in the pearlite area, and will show that this steel contains 100 per cent of pearlite, as before stated. Steel represented by the line drawn from  $B$  to  $B'$ , which is halfway between  $AA'$  and  $OO'$ , will contain 0.45 per cent carbon, and will consist of 50 per cent pearlite and 50 per cent ferrite. The line drawn from  $C$  to  $C'$  will represent material containing 3.75 per cent carbon, and will lie one-half in the pearlite area and one-half in the cementite area, showing, therefore, 50 per cent pearlite and 50 per cent cementite. The material represented by the line  $OO'$  will contain no carbon and consist entirely of ferrite, and the material represented by the line  $PP'$  will contain 6.6 per cent of carbon and consist entirely of cementite. By a similar method we can determine from the chart (Fig. 12) the proportion of pearlite, ferrite, or cementite in steel of any percentage of carbon, it being understood that combined carbon only is considered here, free carbon, which is what we call graphite, not being a normal constituent of ordinary steel. Knowing the properties of pearlite, ferrite and cementite, and determining from the chart the proportion of each in steel of any given carbon, we can estimate from these data something of the characteristics of the steel in question when it is in the annealed condition.

**Properties of Pearlite.**—Steel consisting entirely of pearlite has the finest crystalline structure of any carbon steel, and this is accompanied by the greatest strength and a high degree of hardness. When annealed, this steel also has a degree of toughness, so that it can be bent double while cold, and a wire of about  $\frac{1}{8}$  inch diameter can even be tied cold in a knot without cracking. Furthermore, it is capable of receiving, by hardening or tempering, the greatest possible combination in a carbon steel of

two valuable properties for cutting work, viz., hardness with absence of brittleness. True, tempered steel with less than 0.90 per cent carbon will not be so brittle as pure pearlite steel, but, on the other hand, it will not be so hard, either; and tempered steel with more than 0.90 per cent carbon will be harder than pure pearlite steel, but will also be more brittle.

**Properties of Ferrite.**—Ferrite crystals contain theoretically no carbon or other impurities; in other words, they consist of pure iron. There is no material sold commercially corresponding to pure ferrite, but the purest forms of irons, such as Swedish wrought iron, electrolytic iron,

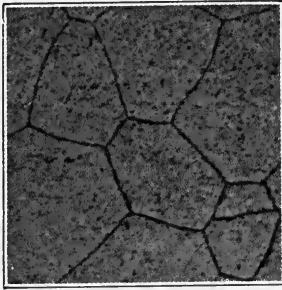

FIG. 13. Ferrite.

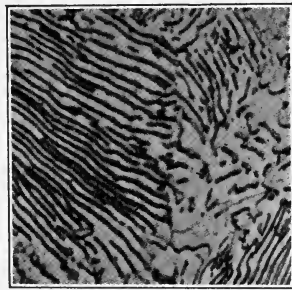

FIG. 14. Pearlite (lamellar).

Both  $\times 1,000$ . From Dr. H. C. H. Carpenter's paper before the Iron and Steel Institute.

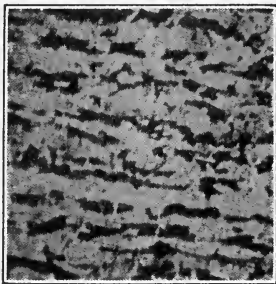

FIG. 15. Pearlite (black) segregated in ferrite.

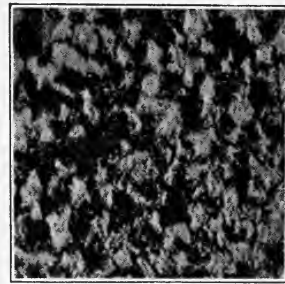

FIG. 16. Cementite (black) with contained patches of ferrite.

Dr. H. C. H. Carpenter. Both  $\times 250$ .

and the most refined products of the electric smelting furnace, come the nearest to it. Those who are familiar with Swedish wrought iron can therefore judge of the properties of ferrite, and need not be told that they comprise great toughness, softness and ductility, together with high electric conductivity and magnetic strength. Crystals of ferrite in cutting tools therefore will decrease their ability to cut, but at the same time increase their toughness.

**Properties of Cementite.**—Cementite crystals contain 6.6 per cent carbon and are a chemical compound of iron and carbon, known as iron carbide, and having the chemical formula  $\text{Fe}_3\text{C}$ . Pure cementite



does not occur commercially, but its crystals can be separated chemically from high-carbon steel, and its properties studied from them. The characteristics of cementite are its brittleness, lack of strength, and great hardness, which latter is not increased by the ordinary processes of hardening or tempering, and cannot be decreased by annealing because annealing of pure cementite breaks up the chemical compound and converts it into a substance similar to annealed malleable cast iron. Even when cementite is mixed with a large proportion of pearlite, annealing or even heating to a bright red will break up the compound to some extent and precipitate some of the carbon, and this is the source of specks of graphite occasionally found in steels containing free cementite, that is, in steels with 1.50 per cent carbon and more.

**Effect of Heat Treatment on Steel.**—The constituents mentioned above are those normally found in steels which have cooled slowly from the temperatures at which they were cast or rolled, or in steels which have been annealed. All of these constituents are changed by heating to higher temperatures, and this is the effect of what is called heat treatment, viz., hardening and tempering.

**Changes Occurring on Heating Pearlite.**—When steel consisting entirely of pearlite is heated to about 735 degrees C. (1355 degrees F.), it undergoes a change in structure and properties. The pearly appearance under the microscope is lost and we see a homogeneous white substance made up of polyhedral crystals to which the name of austenite has been given. At the same time the molecule of steel becomes hard and loses the power of being attracted by the magnet, so that at this high temperature, and above it, steel is non-magnetic so far as the ordinary test shows. When the steel is again cooled slowly below this temperature, the austenitic structure changes back to pearlite, the molecule loses its hardness, and the magnetic property reappears.

**Effect of Heating and Cooling of Pearlite with Ferrite, or of Pearlite with Cementite.**—Most of the steels used for cutting tools are, by composition, chiefly made up of pearlite. Even if there be some ferrite or some cementite present besides the pearlite, the changes occurring in the steel on heating and cooling have ultimately the same effect as that just described, although they occur in a somewhat different way, which will be explained later. For the present, therefore, the changes in all carbon steels will be considered as if they were merely from pearlite to austenite and austenite back into pearlite. When steel with less than 0.90 per cent carbon is heated to about 735 degrees C. (1355 degrees F.), all the pearlite in the steel changes, as before described, into austenite, but the ferrite remains as ferrite for the time being. If the heating continues, however, ferrite is gradually absorbed by the austenite with each rise in temperature. When there is as much as 25 per cent of ferrite (that is, if the steel contains 0.67 per cent car-

bon), the ferrite is not all absorbed until a temperature of about 770 degrees C. (1415 degrees F.) is reached. When the steel consists of 50 per cent pearlite and 50 per cent ferrite, the ferrite is not all absorbed until a temperature of nearly 800 degrees C. (1462 degrees F.) is reached. However, even when there is as much as 99 per cent of excess ferrite, this ferrite is all absorbed and the mass converted into austenite by the time the temperature has risen to 935 degrees C. (1715 degrees F.).

If we have cementite present in excess of the pearlite, instead of excess ferrite, this cementite is absorbed into the austenite somewhat more slowly than the ferrite was. Even with only 15 per cent of excess cementite (steel of 1.90 per cent carbon) the temperature will rise to the point where melting begins (1150 degrees C. or 2102 degrees F.) before the last of this cementite is absorbed. With 9 per cent excess cementite (steel of 1.50 per cent carbon) the cementite is all absorbed by the time the steel has reached 925 degrees C. (1697 degrees F.).

It is evident now that all steels are converted completely into the non-magnetic austenite, with the hard molecule, upon heating to a sufficiently high temperature, and it will not generally be necessary hereafter to distinguish in this regard between steel consisting of pure pearlite and that consisting of pearlite with cementite or of pearlite with ferrite, since the only effect of the excess substance is to raise the temperature at which the conversion becomes complete. The same relation holds good in the cooling of these steels. If there is excess cementite or excess ferrite present, as the case may be, the excess is first precipitated at a somewhat higher temperature than the change from austenite to pearlite, depending upon the amount present, and finally, when all this excess is precipitated, the residual austenite is converted into pearlite. It is to be remembered, however, that if the carbon is below 0.90 per cent, ferrite is later absorbed into the austenite on heating and precipitated in advance on cooling, while, if the carbon is above 0.90 per cent, cementite is so absorbed and precipitated.

**Lag.**—One characteristic of the change from pearlite to austenite on heating, and the reverse change from austenite back into pearlite on cooling, deserves special notice; that is, it is a somewhat tardy one and does not take place instantaneously. On the contrary, it requires a few moments for its completion. We express this by stating that the change lags behind the temperature to some extent, and this tardiness, or lag, is greater the more rapid the heating or cooling is. We may liken it to the tail of a comet. If the comet is traveling through space at a very rapid pace, its tail will drag out behind it for a long distance, but, if the comet is traveling with a relatively low speed, the tail may almost keep pace with it, and may even surround it. So, if we heat pure pearlite steel very slowly, so that it may take many hours, or even days, to reach a bright red heat, the change from pearlite to austenite may

occur all at approximately the same temperature, and if then the steel be cooled equally slowly, the change from austenite back into pearlite may also be completed all at the same temperature. It has been shown that under these conditions of very slow heating and cooling, the change from pearlite to austenite on heating will occur at practically the same temperature as the reversion from austenite to pearlite occurs on cooling, although, with the ordinary rate of heating, the change from pearlite to austenite is not completed until a temperature of about 735 degrees C. (1355 F.) is reached, and with the ordinary slow cooling in the furnace

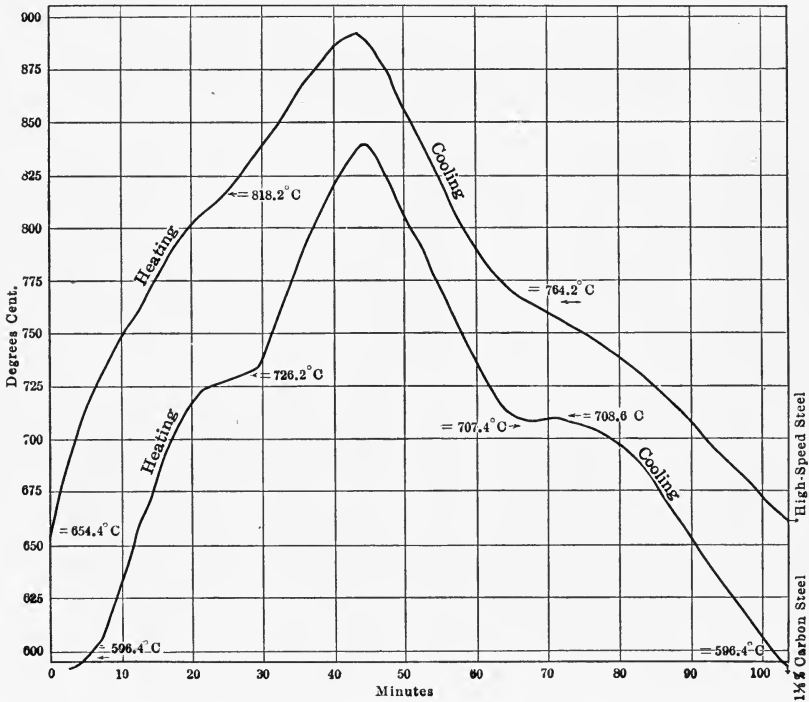

FIG. 17. Curves showing relative location and nature of critical ranges in high-speed and in carbon steels. The lower position of the cooling recalescence range, compared with the heating range, is shown also.

the reversion from austenite to pearlite does not occur until the temperature has dropped to 690 degrees C. (1274 F.). This difference in temperature on heating and cooling is not because the change is not a truly reversible one, but merely because it is a tardy change and lags behind the temperature in both directions. To return to our simile of the comet: If we can imagine a comet traveling with great speed from west to east, with its tail extending a long distance behind, it would have to pass well beyond a given point before the last of its tail would reach that point. If now we should suddenly reverse the direction of the comet, the momentum of the tail would still carry it on and the comet itself would have had to pass some distance beyond the given point in

the opposite direction before it would have again dragged the last of its tail beyond that point. We might even imagine the return of the comet to be so extremely rapid that it would become separated from a part of its tail, and leave it behind, beyond the given point we have been considering.

**Theory of the Hardening of Steel by Sudden Cooling.**—If any carbon steel be heated to a high enough temperature, it will be entirely converted into austenite. If now the steel in this condition be cooled with great rapidity, we may bring it to the atmospheric temperature with a part of its molecules still left in the austenitic condition; and since the austenitic molecule is much harder than the pearlitic molecule, it is on

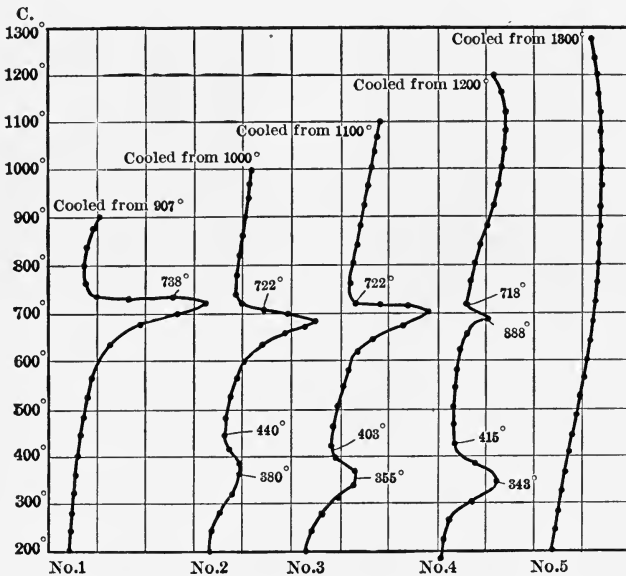

FIG. 18. Gradual reduction and final disappearance of marked variations in the curve (apparent disappearance of recalescence points) on cooling from increasingly higher temperatures. From Dr. H. C. H. Carpenter's paper, "Possible Methods of Improving Modern High-Speed Turning Tools."

this principle that the hardening of steel by sudden cooling is explained. No cooling has ever been so rapid, however, as to obtain all the molecules in the austenitic condition, because, although the change from austenite to pearlite is a tardy one, it is not so slow that we can get away from it altogether.

**Influence of Carbon on the Hardening.**—There are some conditions, however, which aid in keeping some of the steel in the austenitic condition. One of these is the influence of carbon, which tends to obstruct the change and make it more tardy. Thus, with 1.60 per cent carbon in steel, and with very rapid cooling, we may find under the microscope as much as 70 per cent of the mass in the austenitic condition, but this

is about the maximum that has been obtained up to this time by quick-cooling and carbon content only.

Again, the importance of carbon in this respect is shown by the observation that, unless some carbon is present, we cannot retain any of the steel in the austenitic condition, no matter how rapid the cooling or what other elements — tungsten, manganese, chromium, etc. — be present. We may cool it with such extreme rapidity that it is brought to the temperature of the atmosphere in the austenitic condition, but with no more than traces of carbon present it gradually changes over, even when cold, to the pearlite condition. We may express this by saying that we can catch, or trap, the austenite in the steel by means of quick cooling, but we cannot “fix” any of it there except with an

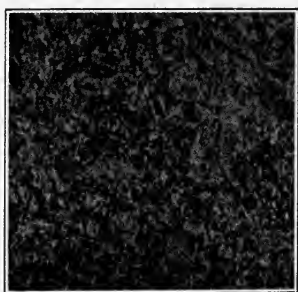

FIG. 19. Martensite.  $\times 150$ .



FIG. 20. Martensite and cementite completely separated.  $\times 1,000$ .

influential proportion of carbon. The tendency of austenite to revert to the normal, or pearlitic, condition at all temperatures below 700 degrees C. (1292 F.) is so strong that it will do so even when cold unless carbon is present as a fixing agent. The colder the steel, the more slowly the reversion proceeds, however.

**Martensite.**—In order to understand the nature of high-speed steels and the reasons why tungsten and other elements, together with the special heat treatment required, produce the effect they do, we must recognize another constituent of steel which is intermediate between pearlite and austenite, and to which the name of martensite has been given. Martensite is probably never a normal constituent of steel, but occurs only as a transition stage in the change from austenite<sup>1</sup> to pearlite.

<sup>1</sup> **Alpha, Beta, and Gamma Forms of Iron.**—Although a knowledge of the nature of austenite, martensite, troostite, and pearlite is not necessary to an understanding of high-speed steels, there are many no doubt who wish to know as much about the tools as it is possible to learn. In order for us to understand the distinction between these different constituents in hardened and tempered steels, we must first understand the varying and compound nature of iron itself.

Pure iron at atmospheric temperatures is the most magnetic substance known to man, with the exception of a recently discovered silicon steel alloy, which it is not necessary for us to discuss here. When this pure iron is heated to and above a tem-

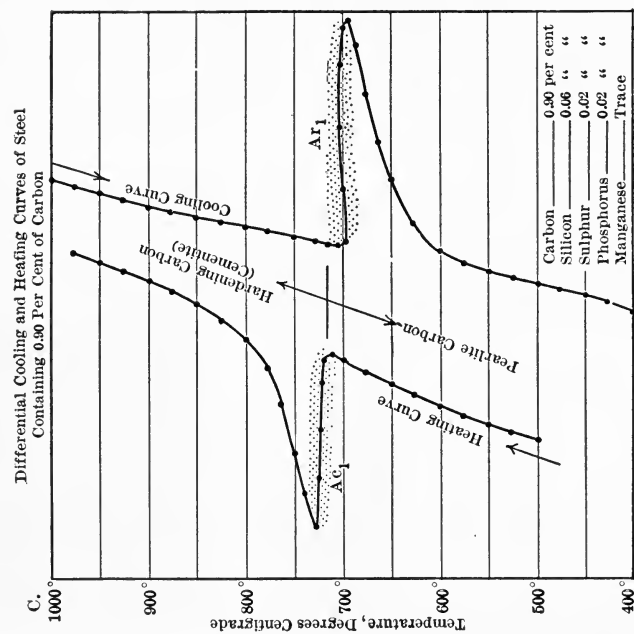

Fig. 22.

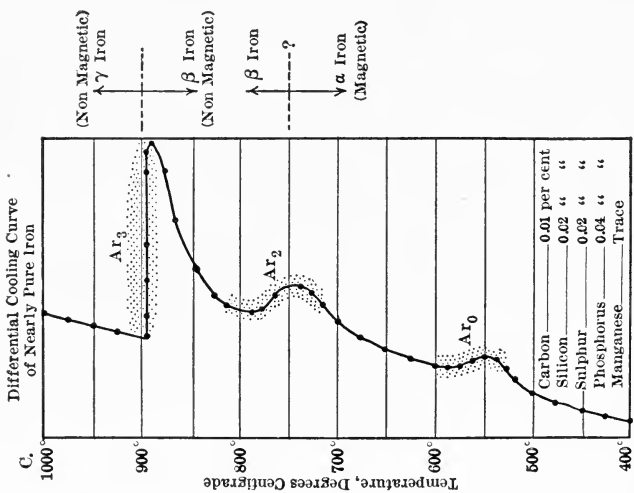

Fig. 21.

How the recalescence points  $Ar_1$ ,  $Ar_2$ , and  $Ar_3$  vary in steels of different compositions, and tend to concentrate in a single point as the carbon content increases. From Dr. Carpenter's paper, "Analysis of the Evolution of Modern Tool Steel."

That is to say, austenite changes first into martensite, but, as this has no normal place in steel at any temperature, it should change at once into pearlite. It is to be observed, however, that the change from austenite to martensite is a very quick one and most difficult to prevent or obstruct, while the change from martensite to pearlite is a much slower one. Martensite is harder and more brittle than austenite, and also more bulky; so that the steel expands when it changes from austenite to martensite, and then contracts again when it proceeds further to the pearlite stage. This expansion explains the occasional bursting of steel tools during hardening.

**Fixing the Austenite and the Martensite.**—The usual heat treatment for hardening tools, which consists in raising them to a bright red heat and then plunging into cold water, is not quick enough to prevent the change from austenite to martensite. Austenite can only be fixed at atmospheric temperatures when (1) the cooling begins from a strong white heat, when (2) it is the most rapid possible, and when (3) the carbon is over 1 per cent. The method of cooling usually employed for this extreme rapidity is to plunge the white hot steel into iced brine or some other liquid cooled well below the freezing point of water. Even under these extreme conditions only a part of the austenite can be preserved unaltered.



FIG. 23. Austenite.  $\times 900$ .

The usual process of hardening produces martensite in the steel, whose hardness, as has been stated, is greater than that of austenite. Unfortunately, however, this hardness is accompanied by too much brittleness to withstand the shocks of service, and generally some of it has to be sacrificed for the sake of durability. This sacrifice is made by means of a tempering process.

**Tempering.**—It has been already said that the colder the steel, the slower the change from austenite to pearlite, after it has been trapped by a hardening process. Advantage is taken of this fact in the temperature of 760 degrees C. (1400 F.), it loses almost completely the power of being attracted by a magnet. At the same time the iron changes its electrical conductivity, its form of crystallization, and other properties. If the heating be continued, the form of crystallization and other properties change again at a temperature of 890 degrees C. (1634 F.). In short, pure iron can radically change some of its properties at different temperatures without changing its composition or individuality. Because the iron remains iron all the time, we therefore call these different forms in which it occurs "allotropic modifications." That condition in which it exists at atmospheric temperatures we call Alpha iron ( $\alpha$ ); that at temperatures between 760 and 890 degrees C. (1400 and 1634 F.) we call Beta iron ( $\beta$ ); and that above 890 degrees C. we call Gamma iron ( $\gamma$ ).

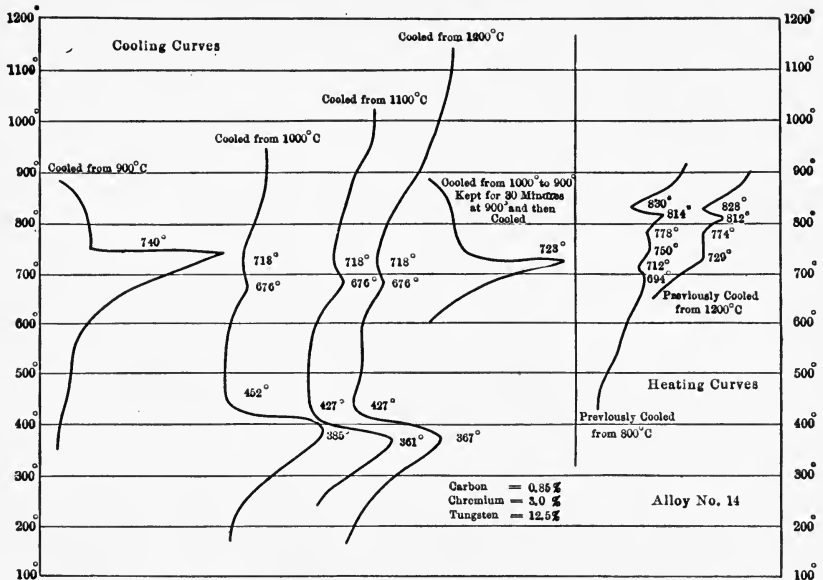

FIG. 24. Curves showing clearly the lower critical point — that connected with the phenomena of tempering.

Movements of the differential galvanometer, about  $\frac{1}{2}$  size. Dr. H. C. H. Carpenter, *Journal of the Iron and Steel Institute*.

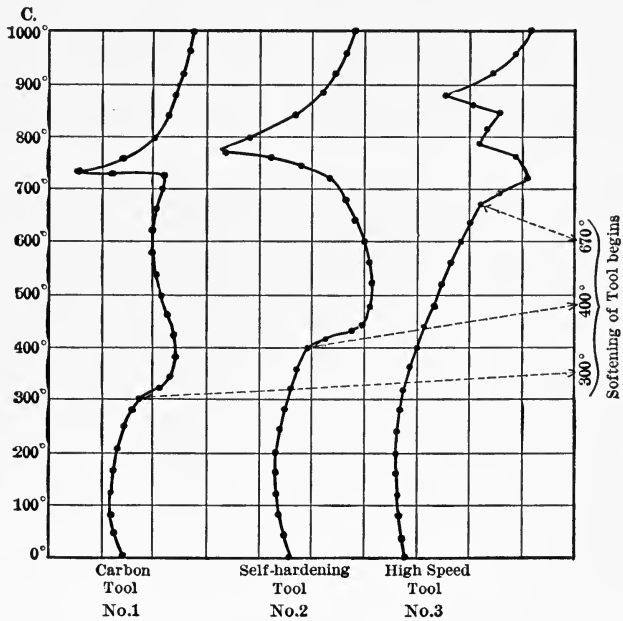

FIG. 25. Curves comparing softening or tempering ranges of carbon, self-hardening, and high-speed steels. From Dr. Carpenter's paper, "Possible Methods of Improving Modern High-Speed Turning Tools."



mon process of tempering. If we have fixed some martensite in a carbon-steel tool, we can "let it down" toward the pearlite stage to any desired degree by gently heating the tool. Softening begins by this process at a temperature of about 200 degrees C. (392 F.). This proceeds more and more as the temperature is raised, and usually is as complete as desired before we reach a temperature of 400 degrees C. (752 F.). All tempering after hardening will therefore take place at the temperatures between those mentioned, and in fact 99 per cent of all tempering of carbon-steel cutting tools is between 200 and 300 degrees C. (392 and 572 F.), while it is only those comparatively few tempered articles whose hardness must be plentifully sacrificed for the sake of toughness, such as springs, screw drivers, cold chisels, etc., in which we let down the martensite by tempering above 275 degrees C. (527 F.).

**Temper Colors.**—Nature has fortunately provided a tolerably accurate and convenient pyrometer whereby the extent of tempering may be estimated by eye; for, at about 200 degrees C. (392 F.) the steel assumes a

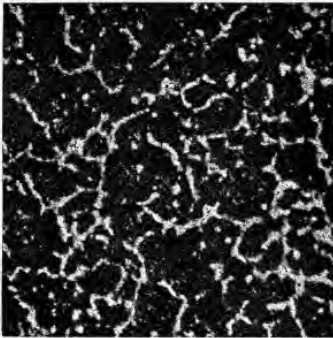

FIG. 26. Heated to 730 degrees C.  $\times$  150.

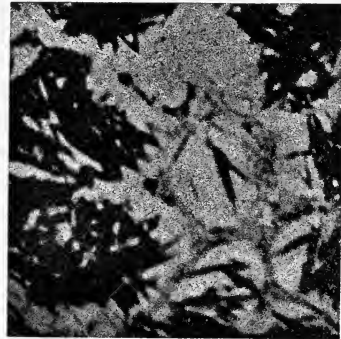

FIG. 27. Heated to 730 degrees C.  $\times$  1,000.

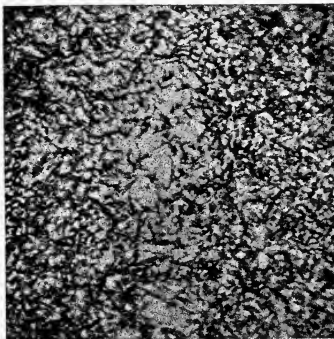

FIG. 28. Heated to 680 degrees C.  $\times$  1,000.

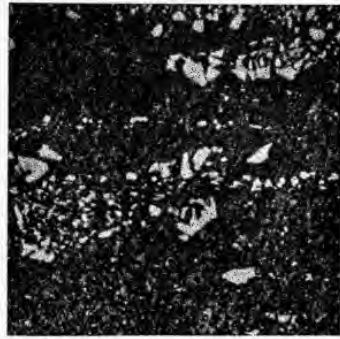

FIG. 29. Heated to 730 degrees C.  $\times$  1,000.

Change in microscopic appearance of high-speed steel due to "low heat" treatment. Composition of steel shown in Figures 36 and 37, C 0.68, Cr 3.01, W (tungsten) 19.37; that shown in Figures 34 and 35, C 0.67, Cr 6.18, W 12.5 per cent.

very light lemon color. As the temperature rises, the color deepens to a faint yellow and then to a straw, pink, light purple, and so on, to a deep

blue. The approximate correspondence of these colors with the different temperatures is shown in the frontispiece of this book. The temper colors are due to a film of iron oxide which forms on the bright surface of the steel and which gets thicker and thicker as the heat progresses.

**Tempering in Oil.**—Steel is sometimes tempered, not by the combination process just mentioned, whereby it is first brought to the martensitic stage by hardening and then let down towards the pearlite stage by warming until the desired “temper” is obtained, but by cooling with intermediate rapidity in the first instance, such as by plunging into oil when at a bright red heat, instead of into water. In this way the martensitic stage is not so completely fixed, and the moderately rapid cooling produces the same effect as if we first cooled with greater speed and then let down the martensite by tempering.

**Troostite.**—Tempered steel consists wholly or partly of troostite, which is a transition stage between martensite and pearlite. Troostite is softer and tougher than martensite, so that the toughness of tempered steel will depend upon the relative proportion of troostite in it, and this latter will depend in turn upon the amount of tempering. Some troostite is found even in hardened steel unless it has been quenched from a temperature nearly a white heat and far above the “critical point,” i.e. the point at which pearlite changes to austenite on heating, and austenite reverts to pearlite on slow cooling.

**Nature of Austenite, Martensite, Troostite, and Pearlite.**—In the present incomplete state of our knowledge of the constituents of hardened and tempered steels, we must accept all theories<sup>1</sup> somewhat tentatively. However, the indications at present are that austenite is a solid solution of carbon<sup>2</sup> in gamma iron, that martensite is a solid solution of carbon in beta iron, and that troostite is a solid solution of carbon in alpha iron. Theoretically neither beta nor alpha iron can be maintained in solid solution with carbon, and therefore austenite is the only stable one of these solutions, and martensite and troostite must be considered as unstable constituents and merely transition stages between austenite and pearlite. In other words, when the solution of gamma iron falls to the temperature at which it breaks up, it changes to the solution of beta iron; this being an abnormal solution at once breaks down into the solution of alpha iron (provided of course that it is not obstructed), and the alpha solution being also abnormal breaks down into pearlite, which is not a solution at all but a mere mixture of crystals of ferrite

<sup>1</sup> The theory of steel hardening here outlined is substantially that proposed by Professor Howe, which is perhaps as widely accepted as any other.

<sup>2</sup> Where we speak of solutions of carbon in gamma, beta, or alpha iron, it is to be observed that the carbon may be dissolved directly in the iron, or it may be in the form of iron carbide, or cementite, and this dissolved in the iron.

and cementite so fine in structure that the high powers of the microscope are necessary to show its structure.

**Effect of Manganese on Hardening.**—Manganese has the effect of delaying the change from austenite to pearlite, and of acting as a fixing agent for the austenite, but both of these influences are different in kind from the influence of carbon. Carbon hinders the change by making it slower. Manganese, on the other hand, makes the change occur at a lower temperature. That is to say, instead of the change on heating and cooling taking place at about 700 degrees C. (1292 F.) it occurs 100 or so degrees lower when there is 1 per cent of manganese present. With 2 per cent of manganese, the change occurs at a lower temperature still, and finally when there is as much as 12 to 20 per cent of manganese present, it occurs at a temperature below that of our atmosphere. In other words, as 12 per cent manganese steel cools from the temperature at which it is made, it ordinarily never gets so cold that it will change over from the austenitic to the pearlitic condition. Therefore, manganese steel, which, as usually made, contains between 12 and 15 per cent of manganese, is what is called a self-hardening steel, meaning that it is normally in the austenitic or martensitic condition, and that even annealing will not change it to the pearlitic condition.

**Heat Treatment of Manganese Steel.**—As has been shown, the change from austenite to martensite is a very quick one, and difficult to prevent. Thus even manganese steel, if allowed to cool slowly in the mold into which it is poured, will be wholly or partly in the martensitic stage at atmospheric temperatures. In this condition it is not only very hard, but also very brittle. By heating it to a white heat (over 1000 degrees C. or 1832 F.), and cooling very rapidly, as by plunging it into ice-water, we can, however, entirely fix the austenitic stage in this steel. This fixation of the austenitic stage makes the steel not so hard as it was when in the martensitic condition, but still very much harder than in the pearlitic. It is also very tough; but unfortunately it has such a low elastic limit that the thin edge of a tool will not stand up under the shocks of service, but crumbles away, so that manganese steel is not suitable for making cutting tools.

**Effect of Nickel on Hardening.**—The effect of nickel on hardening is the same in kind as that of manganese, but it takes about twice as much nickel to produce this effect. As ordinary nickel steel contains usually only  $3\frac{1}{2}$  per cent of nickel, and as it requires about 25 per cent to bring the temperature of the change below that of the atmosphere, commercial nickel steel is not a self-hardening steel, but is used for other purposes.

**Effect of Chromium on Hardening.**—The effect of chromium on hardening appears to be similar to that of carbon in so far as making the change more slow is concerned. With 1 to 2 per cent of chromium in steel and about 1 per cent of carbon, we can get a much more intense degree of

hardness by means of rapid cooling, but not without. That is, the steel is not self-hardening. Although chromium alone will not make a steel self-hardening, yet chromium with a few per cent of manganese (much less than that present in manganese steel) will produce this result. Chromium also has the effect of increasing the elastic limit of steel, especially when it is combined with vanadium. The hardness imparted by chromium is not accompanied by as much brittleness as that induced by carbon. When the steel contains chromium, the amount of carbon is reduced, since the extreme of hardness is not desired, and toughness may be gained thereby. Tools below 1.50 per cent of chromium are very

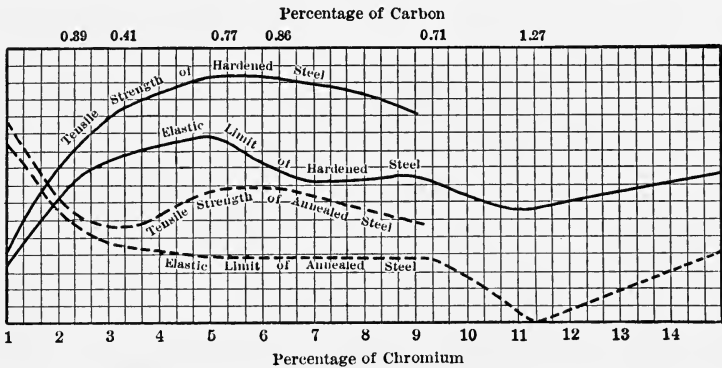

FIG. 30. Effect of chromium on tensile strength and elastic limit. From "Steel and Its Uses," by Edmund F. Lake.

tough and effective in cutting soft materials. High-chromium tools, containing up to 5 or 6 per cent chromium, are very hard and effective upon refractory materials.

**Mushet Steel.**—Chromium with tungsten will also produce a self-hardening steel, although neither of these elements alone will have any such effect. The combination of tungsten with a small amount of manganese will also reduce the temperature of change below that of the atmosphere. The famous old mushet steels, which were the first self-hardening steels, were of this composition and character. Without either a little chromium or a little manganese, however, no amount of tungsten would produce such an effect. The anomaly exhibited by the last steel mentioned in Table III is now explained. That steel contains more than 7 per cent of tungsten, but only 0.3 per cent of manganese and little more than a trace of chromium, neither of which is sufficient in amount to make the steel self-hardening.

**Effect of Tungsten.**—Tungsten acts first as a strong obstruction to all the steps in the change from austenite to pearlite, so that when we have 7 per cent or more of tungsten present, a moderately rapid cooling, even such as allowing the bar to cool in the air, will prevent the change to pearlite. Indeed, when tungsten steels are to be annealed and the

pearlite stage produced, it is necessary that the cooling shall be very slow indeed, occupying several times as long as the annealing of normal carbon steels.

Tungsten acts secondly as a powerful fixing agent for martensite. It has been already shown that martensite is not stable in normal carbon steel even after it has been induced there by hardening, unless the metal be kept cool. Warming it up to the so-called temper heats changes the martensite over to troostite, and if the heating be continued, even the effective hardness of troostite is lost long before the steel reaches a red heat. The presence of 7 per cent or more of tungsten, however, increases the stability of martensite so much that the steel may be heated well above the tempering heats before the martensite even begins to break down into troostite or pearlite.

**Red Hardness.**—Red hardness is the quality of hardness when at a red heat, and tungsten imparts this to steel under certain conditions, for a

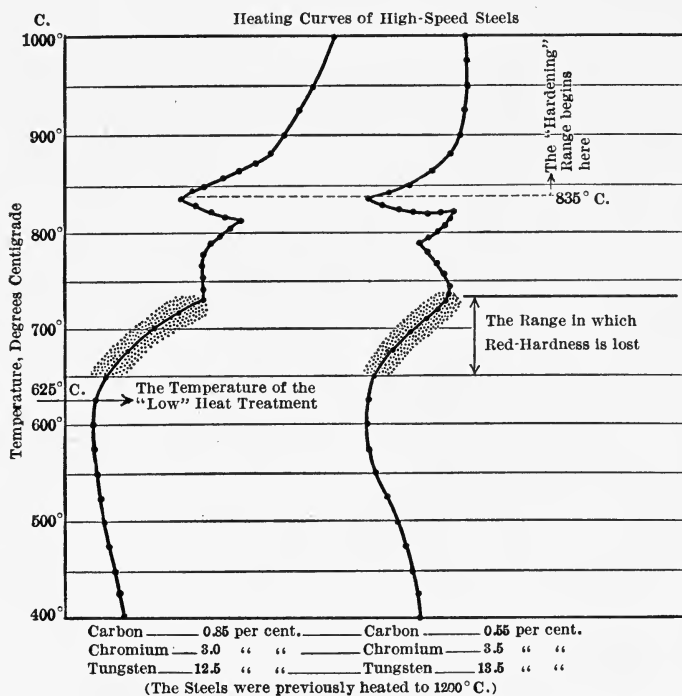

FIG. 31. Curves showing the location of critical points  $A_{r1}$ ,  $A_{r2}$ , and  $A_{r3}$ , in high-speed steels, and the location of the range wherein red-hardness is lost. Taken from Dr. Carpenter's papers.

time at least. That is to say, we may cut with a tungsten steel at so rapid a rate that the point of a tool will reach that temperature where it almost begins to glow in a dark room, and still the steel will retain its hardness for many hours. Finally, however, the hardness is lost to the

steel by remaining continually at this temperature, and modern practice is opposed to working the tool at such a rapid rate. (See Appendix B.)

**Heat Treatment of High-Speed Steels.**—It is now possible to explain the theory of the effect produced by the special heat treatment applied

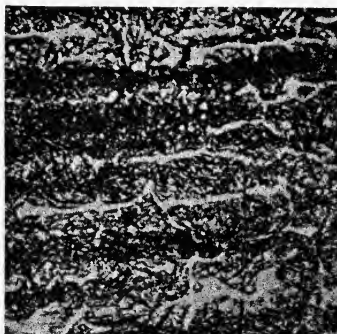

FIG. 32. ( $\times 150$ ).

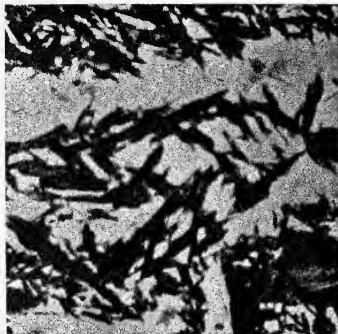

FIG. 33. ( $\times 1,000$ ).

Microscopic structure of the nose of a high-speed steel tool after cutting at its maximum speed for 20 minutes. Long white austenitic streaks imbedded in a martensitic structure. From C. A. Edwards' paper, "The Function of Chromium and Tungsten in High-Speed Steel," *Journal of the Iron and Steel Institute*.

to high-speed tools. The first treatment, that is, a moderately rapid cooling from a very high temperature, is sufficient to retain the steel

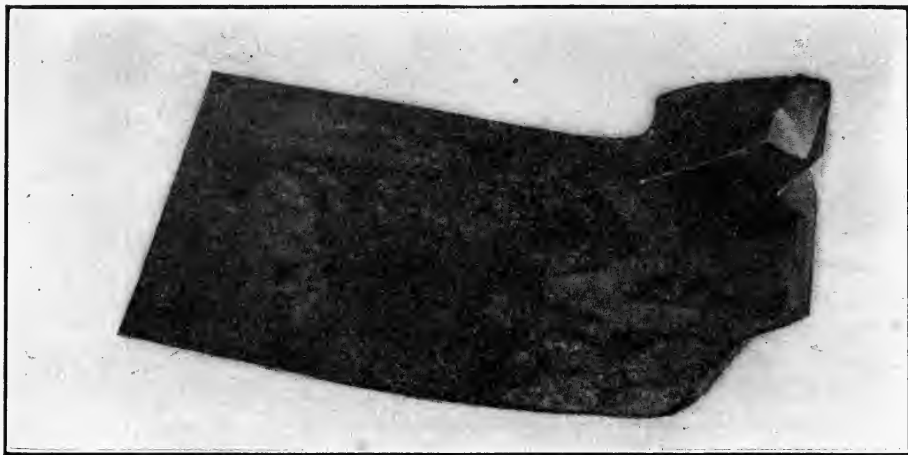

FIG. 34. Tool used in Taylor experiments run at a high cutting speed upon a steel forging. The nicks were filed in with an ordinary file after the tool was taken off the work. The tool evidently is quite soft, in spite of having at the same time a high degree of red-hardness to enable it to stand up under heavy duty. From Taylor's Report.

chiefly in the austenitic condition by virtue of the tungsten present. The second, or low-heat, treatment then changes the austenite partly or wholly into martensite, thus further increasing the cutting efficiency of the tool by increasing the hardness. Subsequently, the tungsten

present acts by preserving the martensite even when the steel is heated up nearly to a red heat by the friction of work.

If we ask why it is necessary first to cool the steel from so high a temperature as to obtain the austenitic structure, and then to let down this austenitic structure to martensite by reheating instead of cooling for martensite in the first instance, it is to be observed that, unless the cooling begins at a very high heat, austenite is changed in part to troostite, and then the tungsten present is not sufficient to prevent the softening proceeding still further, when the steel is heated up by the friction of rapid work. In short, if we allow the change to progress beyond a certain point, it is difficult to check it thereafter.

**Influence of Vanadium on Steel.**—The influence of vanadium is not thoroughly investigated as yet. It has a strong affinity for oxygen and therefore doubtless acts to purify the metal of this injurious impurity. Further than this, its influence when alone in carbon steel does not seem to be always of great benefit, although it has never been shown to have an evil effect. In combination with other elements, such as chromium and nickel, vanadium greatly improves the quality of steel, especially after special forms of heat treatment, as shown by the following test of a steel containing 0.34 per cent of carbon, 1 per cent of chromium, and 0.17 per cent of vanadium:

Elastic limit, lbs. per sq. in.....	222,200
Tensile strength, lbs. per sq. in.....	227,300
Elongation, per cent.....	11.5
Reduction of cross section, per cent.....	42.0

The amount of vanadium present should never much exceed 0.20 per cent, although more than this must be added, for some of the vanadium is lost, probably, by passing into the slag together with the oxygen which it removes. This purification alone is hardly sufficient to explain the markedly beneficial effect of vanadium on high-speed steels, but this subject will have to be left for future investigation.

**Influence of Titanium.**—The only other element whose addition to steel is commercially important to-day is titanium. This has a strong affinity for nitrogen; and it may exert a good effect by removing this impurity, although this is as yet only surmise. The improved wearing qualities of steel rails containing titanium has been proved, and it is known also that it increases the strength of cast iron. It is not yet reported that this element has been tried to any important extent in tool steels.

**Uranium.**—The ores of uranium, on the other hand, occur but rarely. Some experiments have been carried on to determine the utility of uranium as a high-speed steel alloy; but thus far it has not been shown to add any important qualities which are not obtainable by the use of cheaper elements already much used.

**Aluminum.**—Aluminum, often used in the manufacture of ordinary steels as a purifier during the making process, does not appear to add any desirable quality to high-speed steel, and as far as can be learned is not much, if at all, used in its manufacture.

**Tantalum.**—Until recently very little was known of what is perhaps the most curious of all the metals, tantalum. For the matter of that, a good deal still remains to be learned concerning it. Like most other hardening elements, it readily combines with carbon; but the carbides thus formed are not soft, as is the case with the others, but very hard. A small amount of carbon is sufficient to carbonize a large amount of tantalum. It is considerably more than twice as heavy as iron, bulk for bulk; is about as hard, when in the annealed state, as soft steel; and has a tensile strength nearly a third higher. When hardened by alternate heating and hammering, metallic tantalum becomes so hard that a diamond drill will scarcely touch it, at the same time retaining a remarkable degree of toughness. No information is at hand as to its specific influence upon high-speed steel; but it is known that one maker uses tantalum in steel for drills, dies, and tools of like nature. The strong affinity of tantalum (when hot) for oxygen makes it necessary to heat tantalum steel under special conditions such as will prevent contact of the heated steel with the air. The electric furnace is mostly used for this purpose. Tantalum ores are of rare occurrence, and ferrotantalum, the form in which it is used, is costly.

**Importance of Manganese.**—The importance of manganese in the manufacture of steels of all kinds, and its influence upon high-speed steel in combination with tungsten, have been already mentioned. Like nickel and chromium, manganese seems to hinder the formation of the double carbides of tungsten and molybdenum. Steel containing these elements in combination with a sufficient proportion of manganese (or of nickel or chromium) therefore are self-hardening without the high heat treatment, though they are not necessarily high-speed to any considerable extent, even when they receive that treatment. Very high manganese makes steel cold-short and susceptible to fire-cracking. Low manganese does not, apparently, affect the property of red-hardness or temper resistance; but it does tend toward strength and toughness in the body of a tool, while at the same time allowing it to be readily forged and annealed. The apparent effective range of manganese content lies between about 0.2 and 1.2 per cent. If above 2.0 per cent in connection with low carbon, the steel is likely to be very hard and brittle, unless the percentage is also above 6.0 per cent. The tendency seems to be to substitute chromium for manganese above 1.2 per cent. The chromium seems to do the work better than manganese beyond this point, and does not cause the undesirable tendencies above mentioned.



**Silicon.**—Silicon, like manganese, has an important function in the manufacture of steel; but in the proportion usually met with, has no important influence upon the structure or physical properties. An iron-silicon alloy containing from 5.0 to 15.0 per cent of the latter can be readily forged cold, like nickel; but is not forgeable at a red heat. Very high silicon increases the hardness of steel, and at the same time greatly increases the brittleness. A singular circumstance is that an alloy of about 20.0 per cent silicon becomes much harder when slowly cooled than when quenched. In high-speed steel high silicon sensibly lowers the cutting speed, though up to about 3.0 per cent it is said to increase the efficiency, especially upon hard material. Taylor indicates that 0.15 per cent or thereabouts is, all things considered, most satisfactory.

**Sulphur and Phosphorus.**—Sulphur and phosphorus are as difficult to keep out of high-speed steel as out of other steels; and while they probably are slightly less harmful than in carbon steel, nevertheless should be kept as low as possible. The former tends to make steel red-short, and the latter cold-short. More than 0.03 per cent of phosphorus is ruinous.

**Theoretical Formulas for High-Speed Steel.**—It is seen from the above that while there are several agents more or less adapted to steel hardening, most of them are not well enough known, possess certain negative

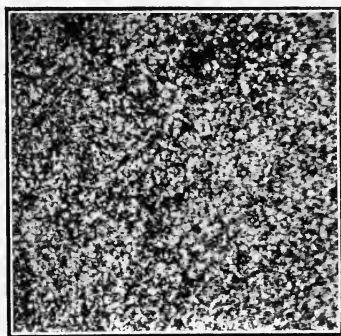

FIG. 35.  $\times 150$ .

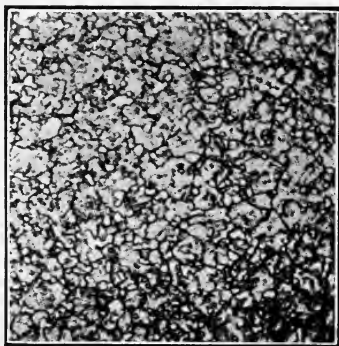

FIG. 36.  $\times 1,000$ .

Microscopic structure of mushet (self-hardening) steel. From Dr. Carpenter's "Possible Methods of Improving Modern High-Speed Steels."

qualities, or are too rare to be available at the present time. Tungsten, molybdenum, chromium, manganese, and vanadium, besides possibly titanium, are now in general use to give tool steel properties not conferred by carbon or to enhance the influence of that element. As has been already mentioned, the influence of any of these elements separately is not necessarily the same as when combined with others; and indeed in most cases there seems to be considerable difference, as for example in the case of tungsten and manganese or tungsten and chromium, already

referred to. So far, therefore, it has not been possible to work out theoretically a formula for a high-speed steel mix. The method has necessarily been that of cut-and-try, further development being along the lines indicated by more or less successful mixes.

**Relation of Mushet and High-Speed Steel.**—If mushet steel was not strictly speaking high-speed, it was at any rate the forerunner of high-speed steel; and the development of the latter grew out of the former. Analyses of self-hardening steels have been previously given. The composition of the original self-hardening steel, R. Mushet's Special, has been frequently stated to be approximately as follows:

Carbon .....	2.0 per cent
Tungsten .....	5.0 per cent
Chromium .....	0.5 per cent
Manganese .....	2.5 per cent
Silicon .....	1.3 per cent

Analyses of several typical self-hardening steels are shown in a preceding table, while analyses for a considerable number of high-speed steels are given in Appendix A. The average composition of some twenty brands of self-hardening steel is shown in the table below, together with the average composition of about twenty-five brands of good high-speed steels.

TABLE IV. COMPOSITION OF SELF-HARDENING AND HIGH-SPEED STEELS.

	Self-Hardening.			High-Speed.			Recommended by Taylor as Best All-round Cutting Steel.	
	Average.	High.	Low.	Average.	High.	Low.		
Carbon .....	1.8	2.4	1.1	0.75	1.28	0.32	0.682	0.674
Tungsten <sup>1</sup> .....	7.3	11.6	4.5	18.00	25.45	14.23	17.81	18.19
Molybdenum <sup>2</sup> .....	4.58			3.50	7.6	0.00		
Chromium .....	1.6	3.4	0.07	4.00	7.2	2.23	5.95	5.47
Vanadium <sup>3</sup> .....				0.30	0.32	0.00	0.32	0.29
Manganese .....	1.8	3.5	0.08	0.13	0.30	0.03	0.07	0.11
Silicon .....	0.56	1.04	0.16	0.22	1.34	0.43	0.049	0.043
Phosphorus <sup>4</sup> .....	0.032	0.080	0.016	0.018	0.029	0.013		
Sulphur <sup>4</sup> .....	0.015	0.050	0.004	0.010	0.016	0.008		

<sup>1</sup> Tungsten is used in all but one of the steels analyzed. In combination with molybdenum the percentage of tungsten is lower than that given.

<sup>2</sup> Molybdenum was found in but one of the self-hardening, and in six of the high-speed steels, in the latter always (with one exception) combined with tungsten. The minimum percentage so combined was found to be 0.48.

<sup>3</sup> Found in but three of the steels analyzed.

<sup>4</sup> The exceeding difficulty of determining such infinitesimal quantities as are involved in the separation of phosphorus and sulphur makes these figures more or less uncertain. In most cases it is possible only to say that traces of these elements exist.

**Mushet and High-Speed Steels—Differences.**—A first glance at the table does not reveal any striking or apparently essential difference between

high-speed and self-hardening steel; and indeed it is stoutly maintained that there is no such essential difference — that mushet steels are high-speed if treated by the high-heat process. When it is remembered that it was with self-hardening or mushet steels that Taylor and White were experimenting, and that it was these that yielded high-speed steels

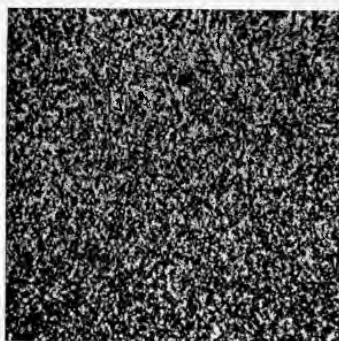

FIG. 37.  $\times 150$ .

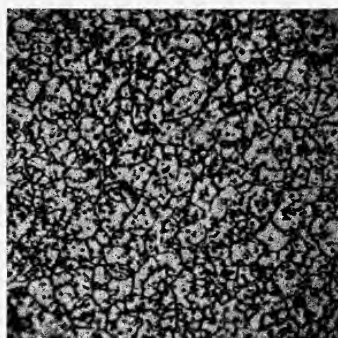

FIG. 38.  $\times 1,000$ .

Microscopic structure of high-speed steels. Typical of all containing more than 9.0 per cent tungsten and 3.0 per cent chromium. From Mr. Edwards' paper.

when subjected to the high-heat treatment, it becomes evident that though not now identical, there is a very close relationship between them. An inspection of the table above will show that the chief differences in composition are these:

	HIGH-SPEED	SELF-HARDENING
Carbon	Medium or low, 0.3 to 1.3%	High, 1.0 to 2.5%
Tungsten	High, 14.0 to 25.0%	Low, 4.5 to 12.0%
Chromium	High, 2.0 to 7.0%	Low, 0.1 to 3.5%
Manganese	Low, 0.03 to 0.3%	High, 0.08 to 3.5%

The differences, it will be observed, are entirely of degree, and not of kind. The total amount of alloy is very largely increased, and in every case the proportions of the ingredients named are inverted. This of course makes a very great difference in the qualities, though not necessarily in the characteristics of high-speed and of the older self-hardening steels. The quality which particularly characterizes high-speed steel is red-hardness, the property of resisting the drawing of the temper when heated even to a red color. But red-hardness is imparted to the alloy steels (suitable ingredients being present) chiefly by the high-heat treatment — that is, by heating these steels to the point where they become austenitic, or gamma. It would be natural to suppose that all austenitic steels necessarily are red-hard to a high degree. This however does not seem to be the case, although the two conditions usually are found together in some degree.

**Steel for Universal Use.**—Thus far, in high-speed steel practice, the disposition on the part of users, as well as of makers, has been to use

one steel for all purposes, tools for cutting hard as well as soft materials (wood among the rest), forming dies, crushers or hammers, rock drills, and all the rest of the category of tools. Most manufacturers make rather extravagant claims for universal high efficiency on behalf of their particular steels. It is true that some steels on the market come pretty close to fulfilling the various conditions requisite to universal service, not only making good cutting tools for hard and soft metal and wood, but being suitable also for forming dies, crushing tools, hammer tools, and the like. For the most part however high-speed steels are adapted to particular rather than general service. Thus a steel highly efficient in cutting hard material often is not so on soft; and one well suited to cutting is not very likely to be well adapted to forming dies and the like. Mr. Taylor mentions one steel tried in his experiments as being superior to all others in all kinds of metal cutting, and gives its composition as shown in Table V, and also in Table IV above. For the sake of comparison the Jessop, Mushet Special, and the original Taylor-White steels also are included in the table. The figures indicate percentages, except as noted.

TABLE V.

Steel.	Car- bon.	Sili- con.	Manga- nese.	Tung- sten.	Chro- mium.	Vana- dium.	Speed. <sup>1</sup>
Jessop carbon .....	1.047	0.206	0.19		0.207		16
Mushet Special. ....	2.150	1.044	1.58	5.44	0.040		26
Original Taylor-White .....	1.850	0.150	0.30	8.00	3.80		60
Best modern high-speed steel ....	{0.674 0.682}	{0.043 0.049}	{0.11 0.07}	{18.19 17.81}	{5.47 5.95}	{0.29 0.32}	100

<sup>1</sup> Cutting speed in feet per minute at which a tool is completely ruined at the end of twenty minutes, working on medium steel.

Though nothing is said as to its efficiency in tools other than those for metal cutting, the composition of this steel indicates that it is also good for all tools requiring toughness and wearing quality; so that it may fairly be classed as an all-round steel. Other things equal it would be highly desirable to have in a shop, or set of shops, one all-round steel equally and in a high degree efficient in all sorts of work commonly turned out. The need for so many varieties of tool steel heretofore has been a source of great inconvenience, frequent mistakes, and untold annoyance — all which would be dissipated could a single steel be economically substituted for all the varieties now in use.

## CHAPTER IV.

### STILL NEWER STEELS.

**Need for Intermediate Steels.**—After the metal cutting industries had begun to adjust themselves to the new situation following the introduction of high-speed steels, the use of self-hardening or mushet steels rapidly decreased until very little call for it existed and most manufacturers ceased making it altogether, putting out instead a more or less excellent quality of the high-speed kind. This however was not for some little time after the Taylor-White discoveries became public. The self-hardening steels had come into rather general use in difficult jobs, and in progressively managed shops were used to a considerable extent on all sorts of work; and so, while the new steels with their wonderful possibilities were justifying themselves and establishing their place, very properly there was a disposition to hold fast to that which had already proved itself, rather than take up something but little known or tried. Recently there has again come to be some demand for steels which, while possessing the qualities of high-speed steel to a moderate degree, enough to adapt them to kinds of work not requiring its high cutting powers and red-hardness, could be bought at a price considerably below that of high grade air-hardening steel; and a number of manufacturers have brought forward steels to fill this gap.

**Field for Semi-High-Speed Steels.**—Certain of these are claimed to be especially adapted to use in blanking, drop, and forming dies, and tools of like nature which are subjected to severe wear but which generate no considerable amount of heat while at work. High-speed steel has lately come into use for such purposes, but where the dies are subjected to tremendous pressures as, say, in the case of cold heading work, they are liable to split. It remains to be seen how well these special or "intermediate" steels will fit into such uses as a substitute for the high-speed kind.

There doubtless are many classes of work wherein a steel of less endurance than the best high-speed varieties would answer every requirement and yield results equally as good; jobs where extremely high speeds or heavy cuts are in the nature of the case impracticable, or as in certain wood-working operations, where a cutter of higher endurance than one of the best carbon steel would have an almost indefinite life anyway. In such cases, it would seem, the high cost of air-hardening steel imposes an unnecessary expense in tool equipment.

**Nature of the Intermediate Steels.**—Most of the so-called “intermediate” steels are nothing more nor less than mushet or self-hardening compositions, although some of them seem to be manganese rather than tungsten steels. A typical example of such a “special,” “intermediate,” or “semi-high-speed” steel, of excellent sustaining power and not exceptionally hard to treat, has the composition:

	Per cent.
Carbon .....	1.190
Tungsten .....	7.560
Chromium .....	3.340
Manganese .....	0.460
Phosphorus .....	0.024
Sulphur .....	0.025
Silicon .....	0.200

Another gave this analysis:

	Per cent.
Carbon .....	0.94
Tungsten .....	4.78
Chromium .....	0.69
Manganese .....	0.27
Phosphorus .....	0.01
Sulphur .....	0.01
Silicon .....	0.11

Both these steels, it will be observed, are rather lower in carbon than most mushet steels were, and the first is rather higher in tungsten while the second is lower in chromium. A third, which scarcely falls within the mushet class is thus composed:

	Per cent.
Carbon .....	1.25
Tungsten .....	2.25
Chromium .....	0.28
Manganese .....	0.85
Silicon .....	0.21

The last is advertised and sold specifically as a “finishing” steel; and it unquestionably gives excellent results in this particular kind of work. Besides these there are a number of other steels on the market, sold for tool use, whose tungsten content (or molybdenum equivalent) ranges from near that essential in a high grade high-speed steel down to that indicated in the analyses above. Most of these are sold as high-speed steels, though at a lower price than is customary for those of the highest grade, and to a greater or less extent they are so, if the chromium content corresponds with the tungsten.

Still another steel very widely advertised as an “intermediate” steel, and doing exceedingly well in certain classes of work, including

blanking and stamping, as well as cutting wood and metals of moderate hardness, has this anomalous composition:

	Per cent.
Carbon .....	1.03
Tungsten .....	0.46
Chromium .....	
Manganese .....	0.30
Phosphorus .....	0.025
Sulphur .....	0.009
Silicon .....	0.008

This is represented as an especially dense steel requiring very slow and careful heating to a cherry red (800 to 850 degrees C. or about 1,470 to 1,550 F.) for cutting tools, and somewhat lower for tools intended to withstand pressure or blows. It is water-hardening, as might be supposed from its composition, and requires the temper to be drawn as in the case of carbon steel tools. It is claimed to be at least 50 per cent tougher than carbon tool steel — though that is about what it seems really to be. Several other steels sold for about the same purposes also have about the same manganese content, and some a good bit higher.

**A Peculiar Non-Tungsten Steel.**—In Europe, more especially in France, there are coming into use semi-high-speed steels of the approximate composition:

	Per cent.
Carbon .....	2.25
Chromium .....	15.00
Manganese .....	0.85

They differ very greatly from the steels constituted according to the now accepted ideas, not only in the absence of tungsten or molybdenum, but in the very high chromium and carbon. This accounts for the exceeding difficulty with which they are worked. As a compensation for this however, they require a hardening temperature of but 900 degrees C. (or 1,650 F.). They are stated to be but slightly inferior to regular high-speed steels in point of service.

**Recent Developments.**—The most recent development in high-speed steels is the announcement and marketing of what have been variously designated the “new,” “improved,” “superior,” and the like, high-speed steels. Astonishing claims have been set forth by makers and others, for these “new” steels. Speeds of two or three, to ten times those attainable with “ordinary” high-speed tools, have been asserted to be possible; and an endurance many times as great has been claimed. And all this with a steel which could be hardened in water!

**The “New” Steels—Claims.**—Tests have not been wanting whose results seem to lend support to the claims made, and the performances of tools made of the steels (mostly English) thus advertised have been

very good indeed. A cutting speed of 500 feet per minute under proper conditions is said to have been attained, while speeds greatly in excess of those usual with ordinary high-speed tools have been claimed. The claim of superiority in cutting speeds has however been usually subordinated to that of greatly increased endurance, especially in cutting materials exceptionally refractory. Thus chilled iron, which can be cut only with some difficulty by ordinary high-speed tools, at speeds usually under ten feet per minute, and then only with very frequent grindings of the tools, have been machined with comparative ease. Hard spots in such work as tire turning, say, present little obstacle to these tools. Grindings can be reduced by a half at least, and, in cases, may be almost eliminated. Such are the claims put forth.

There can be no question of the extraordinary powers of the steels, offered under the new names. Many of the claims made, however, relative to their superiority over "ordinary" high-speed steel, have evidently been based on comparisons with *very* "ordinary" high-speed steels, or with tools differently treated. As a matter of fact there have been a number of high-speed steels upon the market for several years, sold under the regular names and at no increase in price, which under similar conditions have easily equalled, and in some cases exceeded, any reported performance of the so-called "new" steels. Side by side, on regular work, with the same treatment, it has not yet been shown conclusively that the "new" steels are in any respect superior to any one of several American brands whose composition has been practically unchanged for several years.

**"New" and "Ordinary" Steels Compared.**—The fact is, it is very unusual indeed for any tool to be worked to its limit, especially in regular shop practice; and a tool easily capable of running at two or three hundred feet per minute, for reasons well understood, rarely is run half as fast. Furthermore, it is common practice, and good practice too, for tools to be ground more frequently than is absolutely necessary so far as metal-removing capability is concerned. There have indeed been occasional "tests" to show what could be done. The limitations affecting regular work however have in general served to prevent the adoption of the higher limits of possibilities, even when these have been ascertained. A series of experiments carried on since the announcement of the "new" steels, for example, with a machine designed especially for the experiments and with a view to reaching the limit of performance, proved only that the limit of speed could not be reached on that machine. A speed of more than 200 feet per minute, rough turning cast iron, was maintained easily. In another instance a different tool showed itself capable of standing up all day under a speed of 130 to 140 feet per minute while taking a cut  $\frac{1}{8}$  inch deep and with a feed varying from  $\frac{1}{8}$  to  $\frac{1}{4}$  inch. No "new" high-speed steel seems to have excelled this performance, or apparently equalled it.



**Water Hardening.**—The performance first mentioned was with a tool whose point had been hardened by dipping in cool water and then quenching all over in oil, the temper being afterward slightly drawn. A tool so treated would of course be exceedingly hard. To get the astonishing results claimed for the “new” steels, that is, results astonishing when compared with customary performances, the water treatment is likewise necessary. At first there was a disposition to attach much importance to the possibility of hardening in water, and it has been stated that a tool of a “new” high-speed steel has been successively hardened in this manner a great many times without cracking. There would be nothing remarkable in this, especially if the tool contained vanadium, as probably it did. Other high-speed tools also have been hardened in water and made glassy hard. But it is not safe to harden any high-speed steel in this manner, whether of the so-called “new” or of the “ordinary” kind. A tool might be successfully hardened in this manner a dozen times — and again, it might crack the first time. There is no way of knowing beforehand. It is for this reason that the caution is often repeated in this book, not only to avoid water in hardening high-speed tools, but to keep it entirely away from tools either hot or liable to be heated. It is not singular, under the circumstances, that the makers of the “new” steels declare for the customary method of hardening in air or in oil.

**Nature of the “New” Steels.**—The “new” steels unquestionably are good steels, and superior to most, though not all others previously on the market. What superiority they possess over ordinary steels is doubtless due in large part to the increased percentage of alloy, compared with the low proportion generally found in English and continental brands, and in part, very likely, to the presence of such elements as titanium and vanadium, up to this time little used in ordinary high-speed steels. It is noteworthy, however, that one of the very best of the standard high-speed steels (an example of whose performance is mentioned above) rarely yields vanadium upon analysis. The treatment requisite for the “new” steels is essentially the same as for other good high-speed steels. In some cases a rather higher forging heat is recommended.

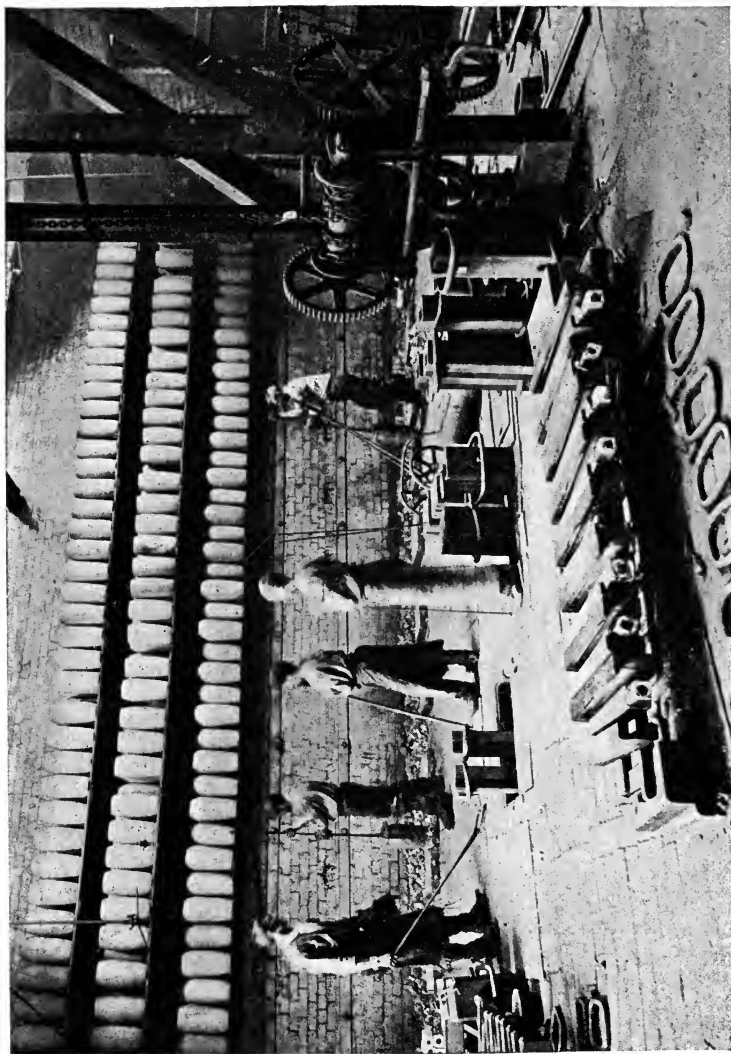

FIG. 39. Melting the steel. Setting the charged crucibles into the coke hole.

## CHAPTER V.

### THE PROCESS OF MAKING HIGH-SPEED STEELS.

**The Crucible Process.**—Mention has been already made of the three processes for making steel, namely crucible, open hearth, and bessemer. Of these only the crucible process produces steel suitable, generally speaking, for use in tools, and especially in cutting tools. It is by this process only that high-speed steel was produced until recently. The



FIG. 40. The furnaces (tops at the floor level) and the crucible pits.

electrical furnace, with its very high quality of product, now is also used to some extent.

The crucible process, the simplest of those in use, is centuries old, reaching back to those days in the misty past into which history has not penetrated. The modern method of producing crucible steel is essentially the same as that by which wootz was made; but of course in its details it has been greatly improved. And though it is the simplest of the three processes now in use, it is by far the most costly. Briefly it

consists in placing together in a clay or graphite crucible, the iron and charcoal, wood, or other substances which are to enter into or affect the final product; setting the crucible in a furnace and melting its contents; and afterwards "working" the product to secure density and form.

**Charging the Crucibles.**—Crucibles, as used in steel making in this country, are usually made of a mixture of 50 per cent graphite and 50 per cent clay. In Europe all clay crucibles are quite generally used. The latter have certain advantages, but are much less durable than those composed largely of graphite. The charge rarely exceeds 125 pounds, and is only 50 pounds when clay crucibles are used. The amount of iron, charcoal (to furnish carbon), tungsten, molybdenum, or whatever other agent or combination of agents is demanded by the formula, is exactly measured in the "mixing room," and this formula once adopted as the result of much experiment, is religiously followed, in order to preserve as close uniformity in the product as possible.

The hardening agents are preferably placed at the bottom of the crucible, and the small pieces of iron carefully packed over them. The crucible is then lowered into the melting hole and a cover placed over it to keep out gases, and the melting hole itself carefully sealed up.

**Melting—Furnaces and Methods.**—The method of placing the crucible in the melting hole, and removing it has changed little since early times. The melter, or more often his helper (sometimes called "puller out") grasps the filled crucible with tongs shaped to fit its sides, and straddling the hole, lowers until the crucible rests upon the floor of the hole or upon a suitable bed of fuel, as the case may be. In like manner the crucible is "pulled" after the melt is ready for pouring.

Obviously this is very hot work. Indeed it is customary for the "puller out" to swathe his legs in wet cloths to avoid being scorched; and even then he not infrequently catches fire and has to extinguish himself. In a very few modern plants, especially where large quantities of metal are made, mechanical methods of handling are employed, generally an overhead trolley hoist operating the tongs.

The melting hole usually is one of several, perhaps as many as twenty. Commonly each hole accommodates four to six crucibles; and generally all are connected with the same main flue and stack, though in other respects each is practically a separate furnace. Where gas is used for heating, the furnace is of the reverberatory kind, with regenerators and checkers; and is provided with suitable valves and dampers for regulating the temperature. For high-speed steel melting this type is most satisfactory because of the ease with which the temperature can be maintained at a very high point and also kept uniform for any desired time.

In some cases the melting is done in an ordinary coke hole, also provided with drafts and dampers for controlling the temperature. The hole is pretty well filled with coke or anthracite piled around the crucibles,

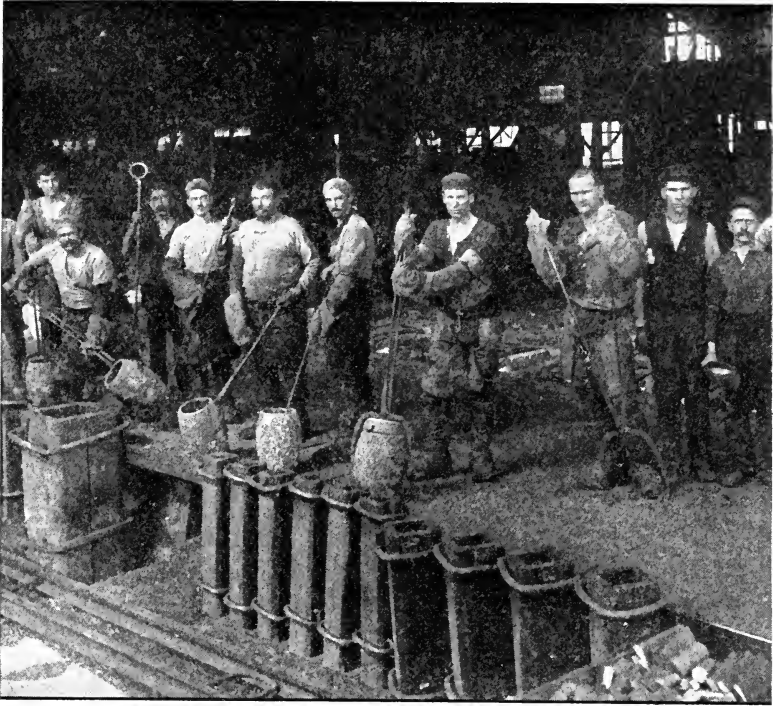

FIG. 41. The stalwart melters.

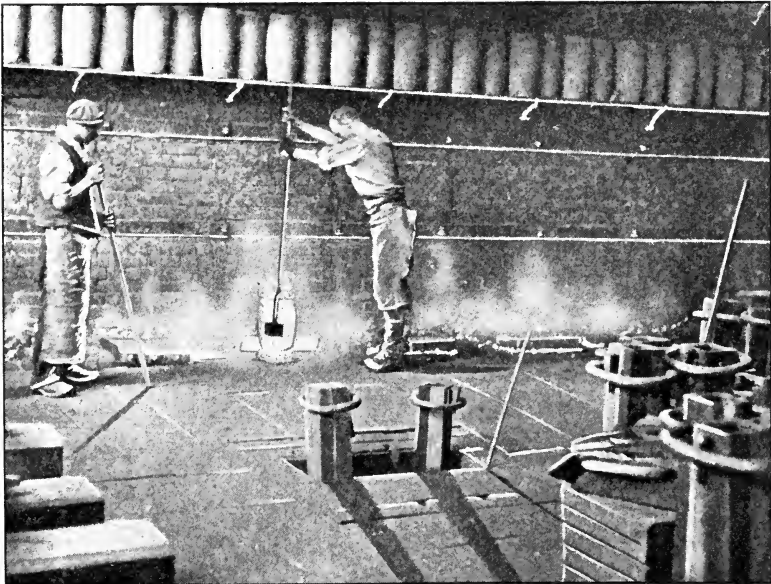

FIG. 42. "Pulling" the crucible.

and the heat gradually brought up to the high temperature necessary, and maintained as long as may be required, care being taken to replenish the fuel from time to time.

Ordinary crucible steel melts in 2 to 4 hours, and rarely requires more than 3 hours, if the stock is not in too large pieces and the furnace is kept well regulated. High-speed steel however requires much longer. For those steels containing manganese 8 hours is not unusual; and for the very best grades of high-speed steel the melting may require as much as 10 hours, and even more, though usually 4 to 5 hours is sufficient. The melter's experience is his chief guide in determining when the melting is complete, and then the melting hole and crucible are opened for examination. For the most part the melter depends upon his eye to determine the progress of the melt, and if he makes a mistake it may be at total loss.

**Killing or Dead Melting.**—In all crucible steel manufacture the “teeming” or emptying of the crucible is not done immediately after the melt

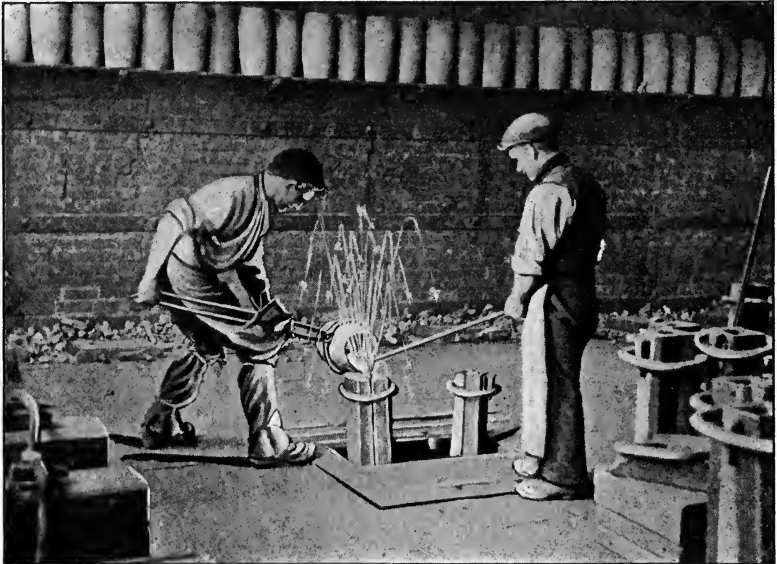

FIG. 43. Teeming or Pouring.

has become sufficiently fluid; but is deferred for a time (rarely up to two or three hours, usually 30 minutes) while it is being “killed” or “dead melted.” This consists merely in allowing the crucible and its contents to remain in the melting hole until the liquid steel has become quiescent and is in such condition that when teemed the resulting ingot will probably be sound, that is, free from blow holes. Killing has an important effect upon the density and uniformity of the steel, due, it is

thought, to the escape of certain gases and the absorption of silicon. The operation is longer or shorter according as the furnace has been relatively hot and the melting rapid, or the furnace cold and the melting slow. The time depends also upon a number of other things, among them the purity of the steel. Usually it requires from twenty minutes to an hour, the eye of the melter again determining when the melt is ready. There can not, in the nature of the case, be any sharp line of demarkation between melting and killing, for the whole combined operation is controlled throughout by the judgment of the melter.

The contents of the crucible must not be allowed to cool to an extent which would affect its fluidity prior to teeming or pouring into the ingot molds. If the metal becomes thick and pasty it does not run well and the resulting ingot is likely to be defective. Molds are customarily small in section, rarely exceeding 4 by 4 inches, and are very deep in proportion to their cross section. Usually they are in two parts, held together by rings and keys. The interior is well smoked before the teeming, in order to give the ingot a smooth surface and prevent its sticking to the sides of the mold.

**Teeming.**—The slag having been skimmed off, the teemer quickly empties the crucible into the mold in precisely the same manner as is done in teeming ordinary crucible steel. Inasmuch as the molds are so small in section it requires a very high order of skill to teem properly, that is, to pour the melted metal so as to fall directly toward the bottom of the mold. The stream must not at any time in its descent strike against the sides.

Ingot molds used in the manufacture of high-speed steel usually hold the contents of but a single crucible, though sometimes larger ones are used for producing ingots of special size for special purposes. In this case several crucibles may be teemed into a single mold, usually after having been mixed in a ladle.

**Finishing.**—The ingot, after cooling and removal from the mold, is "cropped" or "topped"; that is, the top is broken off, to remove the piped and segregated portion likely to be found in this part. The surface of the remaining portion is carefully inspected for physical defects, and such minor superficial ones as are discovered are chiseled out. At the same time a sample is taken for analysis. This proving satisfactory, and no physical defect being found sufficient to warrant the rejection and remelting of the ingot, after a prolonged heating not infrequently lasting two days (for the ingots having been cast in chill molds, are intensely hard) at a temperature close to 800 degrees C., it is put under the hammer and thoroughly worked out into billets. These are again thoroughly inspected, and if perfect go to the hammers and rolls for finishing to the required sections. Most high-speed steels are hammered nearly to shape, and then rolled to a finish. Both hammering and



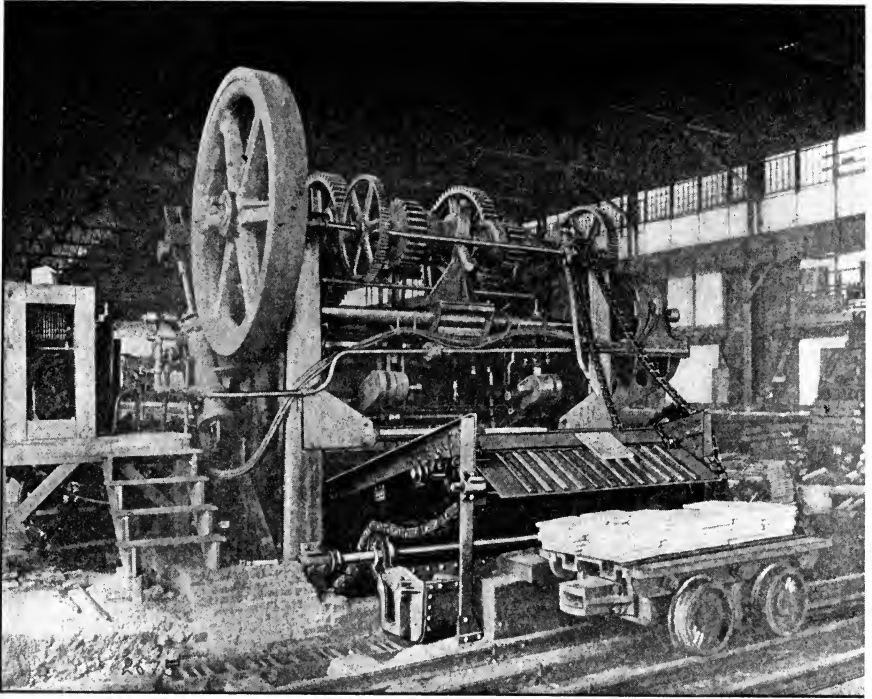

FIG. 44. Billets coming from the shears.

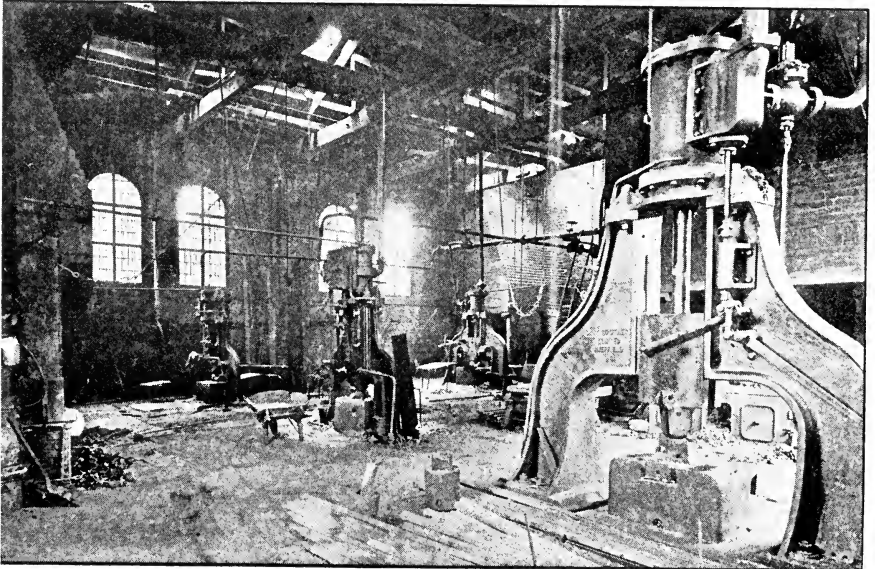

FIG. 45. Forging out the bars under the steam hammer.



rolling must be done at a heat considerably higher than that used in the case of ordinary steels. These alloy steels are so dense that they work well only when at a bright red or even higher temperature. If hammered or rolled at a lower temperature the metal does not flow freely and uniformly under the blows or pressure, and strains, if not cracks, are caused — generally bad cracks, which unfit the steel for its special use. Even if no cracks develop immediately, the strains thus set up, unless let down by subsequent thorough annealing, frequently produce cracks and failures long after the bars have been passed as perfect, and more than likely after they have been put to use. To insure freedom from defects the forging temperature is customarily near 1,000 degrees C. (1850 F.).

**Annealing.**—High-speed steel being partially self-hardening, the bars when finished are hard and require annealing except for a very few purposes. Unless annealed the bars cannot well be used even when they only require to be ground and inserted in a holder, owing to the difficulty of breaking off what may be wanted; and it is utterly impossible to machine high-speed steel in this condition into any of the many special forms required. The hard bars can of course be forged; but even in this case it is much better to use annealed stock, for several reasons, the most important of which is that annealing relieves the internal strains set up in hammering or rolling and decreases the liability to future flaws or cracks. Also, the structure of the steel becomes uniform, homogeneous, and tenacious; and according to the testimony of some, its life is increased.

The annealing is done in muffle ovens of the customary type, the heat being gradually brought up to a red heat of 800 degrees C. (1500 F.) or somewhat higher. The bars may then be removed and slowly cooled, but much better results are obtained when they are allowed to cool in the oven itself, the heat being shut off soon after the desired temperature has been reached, and the oven allowed to cool slowly. As in the other processes, great care must be taken that conditions are just right, else there is likelihood of the steel coming out poor or indifferent in quality, even when the mixture is good. Twelve to eighteen hours, according to the size and shape of the bars, is required for proper annealing.

**Refinement of Methods.**—Those familiar with the process of making ordinary crucible steel doubtless will have noted already that the process of making high-speed steel differs from it in few important respects. In general the equipment used and the methods practiced are identical. The chief difference is in the stock put into the crucible, and in the exceeding care exercised throughout in producing the high-speed steel. In a mill which endeavors to make and keep up a reputation for producing a superior quality of high-speed steel, the extent and frequency

of the examinations and tests of stock in process of manufacture, is surprising. The ingots are carefully analysed, and are inspected before as well as after "topping." The topping itself is intended to remove any possible inferior metal or defects, frequently found in that portion of the ingot. The billet is again inspected; and each separate bar likewise undergoes examination for defects. The bars are generally "pickled" to make defects more easily discernible, if any exist. If defects appear at any time in the course of all these inspections, the material is rejected if inferior in quality, or re-melted if merely defective in structure.

Considering the care necessary in its manufacture, and the high skill required in the workmen, it is not at all singular that high-speed steel continues to sell at the extraordinarily high price which it commands in the market. There are, however, additional reasons for its high price, chief among which is the high cost of the special alloying elements.

**Kind and Quality of Constituent Materials.**—The materials used are necessarily of the purest, and certain of them are rare; for both of which reasons their cost is very high. Some makers use only the purest Swedish and Dannemora iron, saying that these alone are free enough from sulphur, phosphorus, and other impurities, to give the best results in high-speed steel. These irons are considerably more costly than even the best of ordinary kinds. A number of makers however, utilize good qualities of native muck bar, saying that these give results as good as can be obtained; but these extra pure irons also have a higher price than the ordinary. The tungsten, molybdenum, and other hardening metals, vanadium especially, are rare, their ores being found in but few places and those usually not easily accessible. These ores are commonly reduced in the electric furnace, sometimes to the metallic state, and at others to the ferro alloys, either of which can be used in the manufacture of high-speed steel. The prices of these metals range, in either state, from \$0. 40 to \$7.00 per pound.<sup>1</sup> Since the proportion of

<sup>1</sup> The prices quoted in March, 1908, were approximately as follows:

Tungsten . . . . .	\$0.75 per lb.
Vanadium . . . . .	6.00 "
Molybdenum . . . . .	1.50 "
Titanium . . . . .	1.00 "
Chromium . . . . .	.37½ to .75 "

The figures given are for the contained metal in the ferro state. Swedish iron was at the same time quoted at about three cents per pound.

Ten years before these metals were stated to be worth a great deal more, as may be seen from this quotation taken from the columns of a scientific paper of the time:

Tungsten . . . . .	\$36.00 per lb.
Vanadium . . . . .	10,780.00 "
Molybdenum . . . . .	245.00 "
Titanium . . . . .	1,100.00 "
Chromium . . . . .	490.00 "

hardening metals is not infrequently above 20 per cent, it is seen that the cost of material alone is something quite different from what it is in the case of ordinary steels.

**Possible Lowered Cost.**—In spite of the keen competition among makers, the price of high-speed steel has remained practically where it was when first put upon the market, for the best grades not far from \$0.70 per pound, in small quantities. The so-called "new" steels sell for considerably more. This seems altogether out of proportion, at first thought, even when the high cost of manufacture is considered. It is to be remembered, however, that this includes the as yet high cost of marketing; and must, of course, cover in part, also, the great expense of continued experimentation necessary to determine the most desirable composition and method of production. The cost of certain of the hardening constituents has increased considerably of late, owing to the large demand; but it may be expected that new sources of supply will be located and the methods of extracting the metals and ferro alloys will be so simplified that this cost will be materially reduced. It is becoming known, also, that the more rare of these agents are by no means essential to a good grade of high-speed steel; for other and less costly ones can be combined so as to give satisfactory results, especially for that intermediate class of tools of which the highest duty is neither required nor desired. Apparently the marketing of the new steels is as yet one of the most costly items to the makers. As the place of the new tools becomes more and more definitely established the cost of bringing it to the attention of users will of course decrease, and the total cost to the consumer will without doubt be more nearly commensurate with what would be expected, and the economic value of the new steels be correspondingly increased.

## CHAPTER VI

### FORGING THE TOOLS.

**Stinted Use of High-Speed Tools.**—The demonstrated utility and all-round superiority of high-speed steel for tools in most lines of metal working, and in other lines also, would lead to the inference that they are used to the largest possible extent. A recent study of machine shop conditions has shown conclusively that while they have taken a very large place in productive industry, the new tools are not used to anything like the extent they might be with profit. In comparatively few shops is high-speed steel largely used; in most, to a very moderate extent only; while in a great many it is quite unknown.

**Unsatisfactory Experiences.**—Conservatism of course plays a large part in this condition of affairs, while unfortunate and misleading experiences seem to be responsible for the indifferent or negative attitude in many quarters. That there have been unfortunate and misleading experiences is for the most part due to the unintelligent manner in which the new problems of using high-speed tools is generally attacked. Persuaded in one way or another to buy some high-speed steel, the management of a shop more than likely turns the stock over to the regular tool makers, who are in this case almost sure to be unfamiliar with its properties and the methods of treating it — and more than likely also, prejudiced against such new-fangled stuff. Under these circumstances it is not surprising that tool makers so often fail to profit to the largest extent by the directions furnished with the steel. Even when these necessarily brief and incomplete directions are followed as faithfully as possible, the inexperience of the smith makes his efforts more or less experimental, and the results may or may not be satisfactory.

**Purchasing Tools to Specifications.**—The obvious thing to do, as pointed out in another place, is to buy tools made to specifications, for such introductory experiments. This also is the proper procedure in small shops using few special tools, after they have gone into regular use. Makers are quite ready to furnish tools of any pattern to specifications designating precisely the material upon which they are to work and the machine and other conditions under which they are to operate. In this way there can be little question of the results being satisfactory.

**Making Simple Tools.**—The making of the common forms of lathe and planer tools is so simple a thing however that it can be undertaken

in almost any shop having tool-dressing facilities — provided the smith is willing to forget, for the time being, some of the things he already knows concerning carbon steels, and also to learn a few things which may be quite surprising to him, particularly if he has no experience with high-speed steel. His knowledge of colors, as a guide to heating and tempering tools, for instance, will be no guide at all, and is likely only to mislead him.

Whether it be in a large or a small plant, unless the work is in the hands of a trained expert, the first experiences in the making of high-speed tools should be with the simpler forms already indicated. These usually require little in the way of special appliances in order to give fairly satisfactory results. In their making, nevertheless, is involved the same special knowledge as to treatment which is necessary in the case of more complex tools.

**Use of Tool-Holder Stock.**—Formerly it was a common practice to use high-speed lathe tools in connection with tool holders, merely breaking off from the bar a piece of the desired length, grinding it to the required point, and inserting it in the holder. This is still largely done where the work is light and the speeds not intended to be very high. The unannealed stock was once quite generally used for the purpose. This stock, however, while very hard, has not (in the case of most brands, at any rate) passed through a proper hardening process, having acquired its hardness while cooling under the stresses of the rolls or blows of the hammers. To insure an even temper and the absence of strains which tend to imperfections and therefore short service, it is necessary to anneal the tool pieces, and then to harden them properly. For this reason, as well as for greater ease in separating the desired piece from the bar, the annealed stock should be used, thus avoiding the annealing process in making the tool.

**Cutting Stock from Bars.**—High-speed steel bars which have been so annealed can be easily nicked and broken off, unless of large section. In that case it takes an expert to do it. Breaking however is not advisable, for it is likely to cause a disarrangement of the structure of the steel near the fracture, sufficient to damage the tool at that place. Frequently fine cracks are started which later develop, and eventually spoil the tool. It is safer, and when the nose of the tool is to be forged any way, causes no additional labor, to heat and cut off hot. In general also it is more convenient to forge tools of this sort before cutting from the bar. Where many pieces are used, especially if little or no forging is required, whether of the same or different lengths, it is cheaper to saw them off to length by a power saw. It is unnecessary to do this one at a time, for if clamped tightly enough and sawed close to the support, a large bunch of "tool holder" stock, for example, can be sawed through as if it were a solid bar. As between a band and a circular saw, the former is preferred.

Most such cutting can be avoided by purchasing tool-holder stock ready cut to desired lengths.

**Advantages of Annealed Stock.**—In making tools requiring more or less machining there is an additional advantage in the use of the annealed stock, in that it is readily machined — almost if not quite as easily as carbon steel used for the same purposes. In some kinds of tools this is of considerable importance. Again, the annealed stock is stronger, that is to say, tougher; and tools made from it are therefore better able to

resist stresses in the neck or shank than if made of the unannealed, and on that account are less liable to breakage at those points. The tremendous stresses and strains accompanying the use of these tools makes it important to look to this matter. The early complaints against unevenness have almost wholly ceased since makers, mindful of their own interests as well as of the interests of the users of their steels, have made a practice of sending out annealed bars only, except upon special order.

**The Forge Fire.**—For forging, any good fire, a common forge fire among the rest, will serve; though indeed here, as in other cases, the better results can be expected where the better appliances are used. The first essentials are to secure the required heat and to keep air currents away from the tool while heating. This is accomplished in part by keeping a deep and clean fire. Coke is better than the ordinary smith's soft coal, the latter having a tendency to burn out too rapidly. Very good results are occasionally obtained in this way,

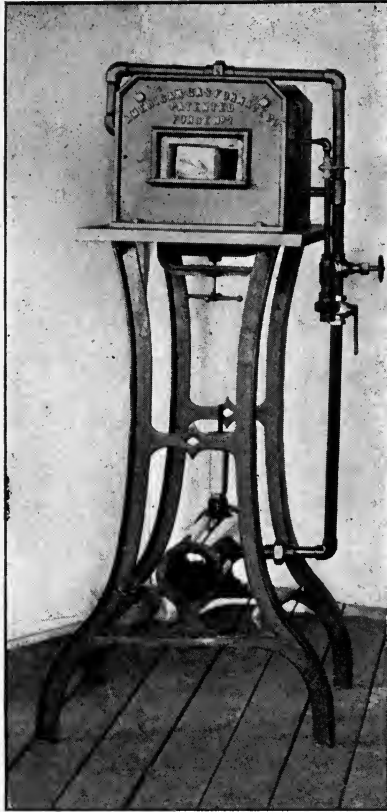

FIG. 46. Good type of gas forge. Made by the American Gas Furnace Co., New York.

though they cannot be expected as a regular thing. If a forge fire *must* be used, a hood of fire brick should be laid up over the fire to prevent radiation and the circulation of air currents. This hood makes it somewhat easier to conform to another prime essential in forging high-speed steel, namely, that the piece be brought up to the forging heat gradually so the heat penetrates uniformly to the very center. This is exceedingly important and will be mentioned again.

**Advantage of Good Equipment.**—Although it is possible, as has just been said, to obtain good results with very primitive appliances, it does not pay to try to get along without suitable apparatus if even a few high-speed tools are regularly produced. These tools are of no especial value above ordinary ones unless they are made uniform and exactly to the specifications requisite for the various special duties to which they are set; and it is the height of folly to spend good money for tools indifferently made. Especially where many tools are required, suitably designed furnaces and other appliances are absolutely essential to the obtaining of satisfactory results.

**Convenience of Gas Furnace — Coke Fire.**—For forging, a gas furnace is unquestionably the most convenient; and in the long run it is probably as economical as any other. Some users maintain it is more so, in the matter of fuel cost, maintenance and tool output. However that may be, the coke furnace, when properly designed, is very satisfactory and efficient.

The gas forge has much to recommend it — convenience, cleanliness, minimum attention to operation and maintenance, ease of regulation, and uniformity of results, among other things. Customarily of the oven type, it is provided, as is the case with gas-hardening furnaces also, with air under slight pressure, say one to two pounds, and suitable means for controlling the flow of air and gas and for properly mixing them in order to insure perfect combustion and economy of gas consumption.

**A Good Coke Furnace.**—The coke furnace is much used, both for forging and hardening. Where the amount of work done is comparatively small, the same furnace will answer for both purposes, as also will the gas forge. A good form, easily built and as easily operated and maintained, is illustrated herewith, Fig. 47. Essentially it consists of a sheet

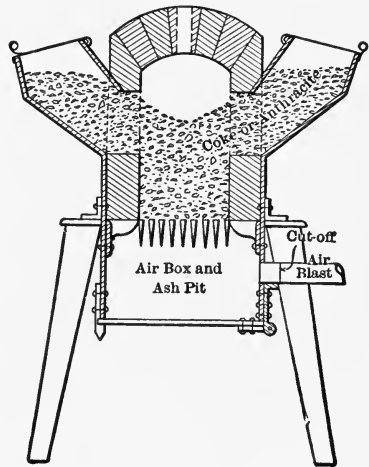

FIG. 47. A simple coke furnace adapted to either forging or hardening.

metal or cast jacket enclosing the fire-brick heating chamber. Sheet metal fuel hoppers are at each side, so placed that the supply of coke or anthracite (either may be used, if in small lumps) is continuous and is fed directly to the top of the fire bed. The result is a hollow fire of uniform temperature, the fuel being gradually heated in its descent, to the temperature of the deep fire bed. The latter, filling the chamber to the fore plate, or perhaps slightly above, rests upon a sectional grate of cast iron, preferably arranged so as to be rocked when shaking down

ashes. The ash pit is also a wind box, whence air under slight pressure from the blower is forced up through the fire. The temperature is regulated to a nicety by the damper in the exhaust and the cut-off in the air supply pipe, and that with almost no attention. When not in use, the fuel is conserved by entirely shutting off the drafts, the amount consumed then becoming negligible. As the gases from a coke fire are almost or wholly non-oxidizing, a tool is not likely to be injured when heated in this way. An important advantage possessed by this form of coke furnace is that the heat is almost wholly confined to the fire chamber, so that there is no waste of fuel, or discomfort for the operator.

**Gradual Heating Necessary.**—The heating proceeds at a moderate rate, neither too rapidly nor too slowly. In the former case the heat does not penetrate uniformly to the center and in the forging the steel does not flow freely under the blows of the hammer, with the results hereafter pointed out. There is danger also that cracks will be formed because of the strains set up through the unequal expansion of exterior and interior. If the heating goes on very slowly the heat soaks up into the neck or shank of the tool, and when hardening takes place, unless the tool is annealed before that operation, this part has lost much of its natural toughness — a thing to be avoided, as already pointed out. In the case of unannealed stock, which is hard anyway, the slow heating is of less consequence. The fire therefore must be clean and well supported by good fuel in the case of a coke furnace, and well regulated in that of the gas furnace. In all cases it must not be too keen, for then the outer parts of the tool are almost certain to become very hot before the interior reaches a forging heat, that is to say, at least a bright red. It is of course, impossible to know precisely the interior condition of a heated piece of steel in ordinary practical operations, so that the smith must be guided very largely by his experience and judgment as to the proper time during which a particular tool is to be heated. It is safe to assume, in general, that a piece having a section not greater than one inch, if properly protected, or if heated in a good gas or coke furnace as already described, will be ready for forging when the exterior has reached a bright yellow.

**Effect of Uneven Heating.**—No hammering should be done under any circumstances while the portion of a tool that is being forged is under a good red heat. Neither should the interior be considerably hotter than the exterior, as is likely to be the case when the tool is large and forged on a cold anvil. The disregard of these cautions is almost certain to result in defective tools. The consequence is shown in the accompanying Figures 48 and 49. When forged with the center much hotter than the outside, the former remaining expanded to a greater degree than the latter when the forging is finished, contracts on cooling, with the result that there are minute openings within, while the outside appears



perfectly sound (Fig. 48). If, on the other hand, the outside be flowing freely while the interior is still too cold to forge readily, the outer portion on cooling contracts over the hard inside and in consequence there are likely to be many fine cracks on the surface, as shown in Fig. 49. Not infrequently these defects are not evident, and make themselves known later, during the grinding or machining (in the case of tools requiring this), or more likely during the hardening. Sometimes the damage does not manifest itself until the tool is set



FIG. 48. What is likely to take place when the interior of a tool being forged is much hotter than the exterior.

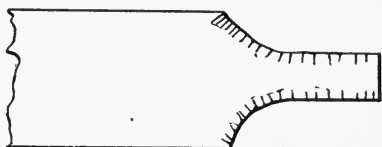

FIG. 49. Result likely to occur when forging with exterior of tool much hotter than interior portions.

to its work, possibly not until sometime after, when greatly to the surprise of the user it suddenly fails without apparent cause.

**Forging Temperature.**—It is better to do all forging at an orange or even a canary yellow than below that temperature, for it in large measure obviates the danger of imperfect working just pointed out. High-speed steel is difficult enough to forge anyway, considerably more so than ordinary steels, though less so than the self-hardening steels; and it is well to keep it as ductile as possible. The various makers of these steels generally give very brief directions as to the forging heats to be employed, in a number of cases indicating that a good red is high enough. In general it may be said that while this is usually high enough, the reasons already stated are sufficient to

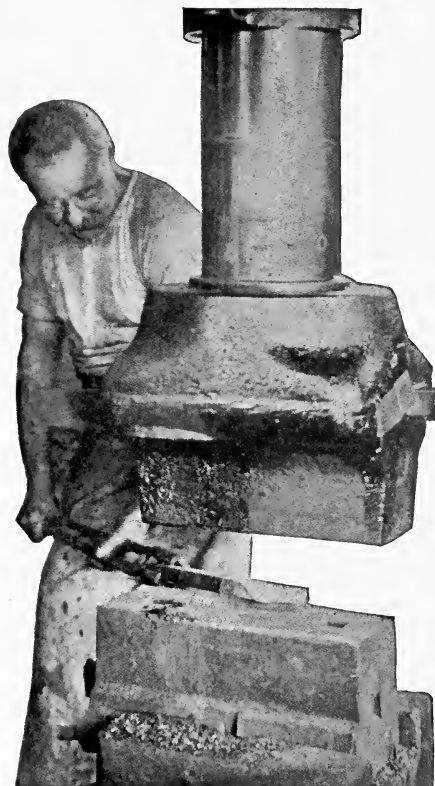

FIG. 50. Heel of tool being drawn down under steam hammer to give support to the nose almost directly beneath the cutting edge. A power hammer allows rapid forging of large tools and is on that account very desirable.

make the higher forging heat desirable in practically all cases. Even in the case of inferior high-speed steel the forging heat must be high enough

so that there is no metallic ring under the hammer, only a dull sound. The temperature range recommended is something like a hundred or a hundred and fifty degrees from and above 1,000 degrees C., or from about 1,850 to nearly 2,250 F. Precise temperatures are, in forging, not a matter of particular concern, the colors being sufficient guide if care be taken to keep the temperature of the interior and of the exterior approximately uniform and well above the minimum bright red already suggested.

**Cautions as to Hammering.**—The proper heat having been obtained, the forging is done in the customary manner. Inasmuch however, as

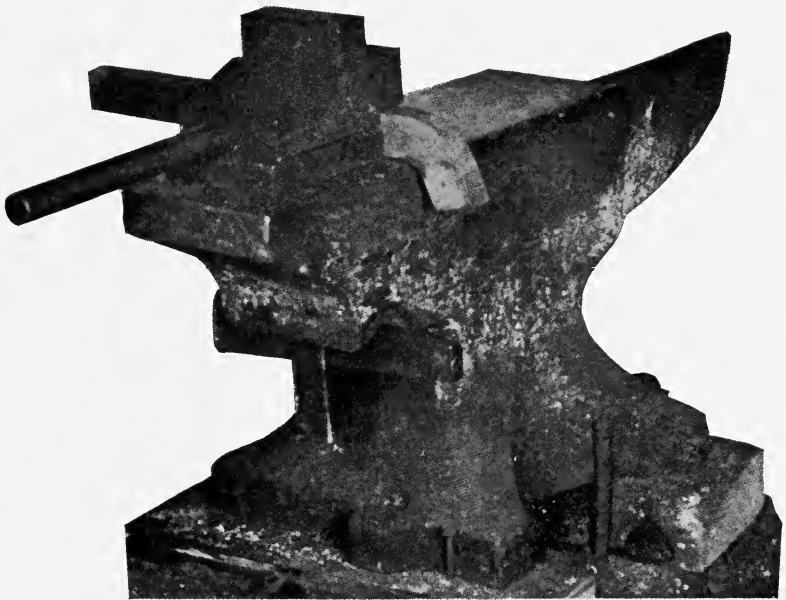

Fig. 51. Tool bent down across edge of the anvil ("turned up").

high-speed steel works somewhat harder than ordinary steels, it is necessary to exercise some discretion with respect to the force of the blows. Indiscriminate hammering is likely to prove ruinous. A large piece needs to have the blows heavy enough so that their force sinks into the interior instead of being absorbed at the surface alone. On the other hand, a light tool would be ruined by heavy blows unsuited to its size.

It is important also that the forging be done rapidly, so as to be completed in one heat if possible. This helps to avoid the troubles just described. Tools requiring considerable working, as in the case of the Taylor standard lathe tools, for example, generally require at

least two, and sometimes three heats, according to the tool and the number of helpers or the use or nonuse of a power hammer. The latter not only saves labor, but is likely, especially in the case of heavy tools, to add considerably to the excellence of the forging.

**Successive Steps in Forging.**—Concerning the successive steps in the forming of a tool, and the special methods to be employed, it would



FIG. 52. Forming a bent side tool.

seem scarcely necessary to say much. The steps are practically the same as those in the making of a tool from ordinary steel, and the methods may be about the same also, except that it is well to take into consideration the fact that the tungsten steels forge with greater difficulty than carbon steels do, and that in bending and similar work it is desirable to resort to certain expedients for facilitating the work, as shown in the accompanying illustrations, Figures 51 to 56 inclu-

sive,<sup>1</sup> some of which show the methods recommended by Mr. Taylor. The clamp attachment for the anvil, shown in Figure 51 is of particular interest. Its application will be readily understood from the illustration.



FIG. 53. Forming a side roughing tool.

**Close vs. Rough Forging—Gages.**—It is well to shape the tool as closely to the required form and dimensions as possible without over refinement, in order to save grinding. Of course there is an economic limit to the closeness of the forging, for when this approaches refinement, it is cheaper to grind. It is desirable to use gages freely for testing the form and size of tools as the work progresses. In some cases forms have been used in connection with the anvil (Fig. 55), in which the shapes are forged with precision but without great expenditure of time.

<sup>1</sup> Figures 50, 51, 54, 56, 57 and a number of others throughout this book, are taken from Mr. Taylor's Address. Figures 52, 55, and several others also, are used through the courtesy of the Gisholt Machine Company.

Customarily a combination gage, giving all the required angles of a particular tool, will be sufficient. Mr. Taylor, in his report already mentioned, describes and illustrates along with others, a surface plate and cone gage, here shown in Fig. 56. The plate has a hole in one corner, into which fit the dowels of various cones giving the desired angles. The limits gage, intended to be used in the making of the Taylor standard lathe tools, also is illustrated, at Fig. 57. This indicates the extreme limits within which the forging must be done. The limits may vary in different shops according to the adequacy or inadequacy of the grinding facilities. The cheaper the grinding cost, the less accurate of course may be the forging.

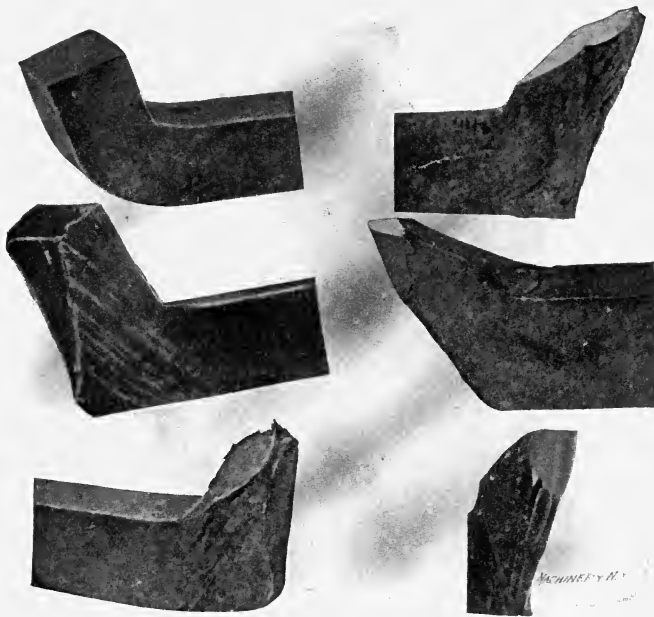

FIG. 54. Successive stages of forged and ground tools. Courtesy of Machinery.

A very simple and convenient gage, Fig. 58, which, however, does not give precisely the actual lip slope, consists of a small piece of sheet metal giving all the angles of a particular tool. A surface plate is almost essential in connection with this gage. Not quite so simple, but very convenient, is the gage shown in Fig. 59. This resembles somewhat the Taylor limits gage, but gives only the minor limit of the nose form. In addition it gives, as the Taylor gage also might be made to give, all the other angles required. Of course, a set of gages is required, one for each tool made in quantities sufficient to warrant the expense.

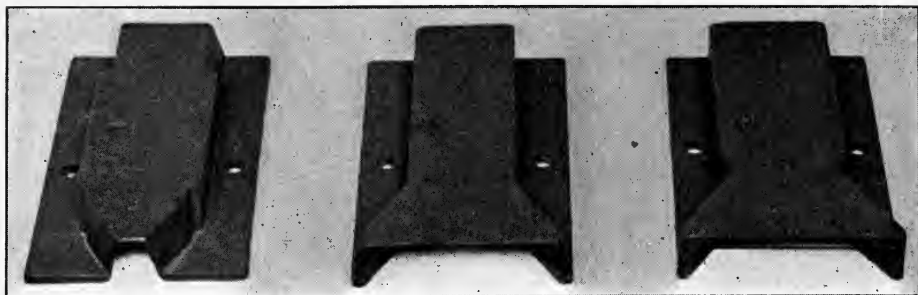

FIG. 55. A set of forming blocks to be used in forging lathe tools, furnished by Gisholt Machine Company with their tool grinder and form chart.



FIG. 56. Trying tool against cone gage to test proper angle for nose.

Form gages should provide for an allowance of  $\frac{1}{16}$  to  $\frac{1}{8}$  inch which is to be ground off the working edge of the tool. Even when gages are deemed unnecessary, this allowance is to be made by the smith; other-

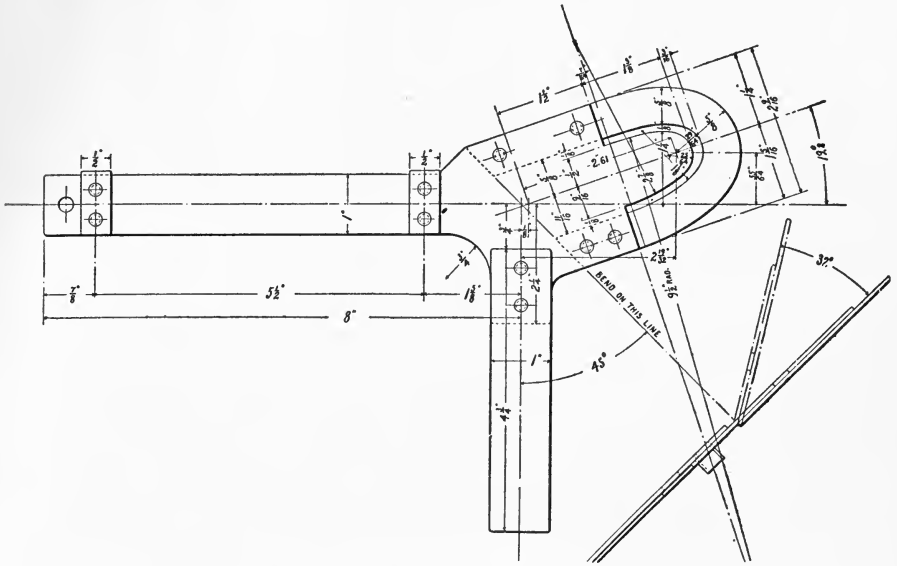

Fig. 57. Limit gage for forging the 1-inch Taylor round-nose roughing tools.

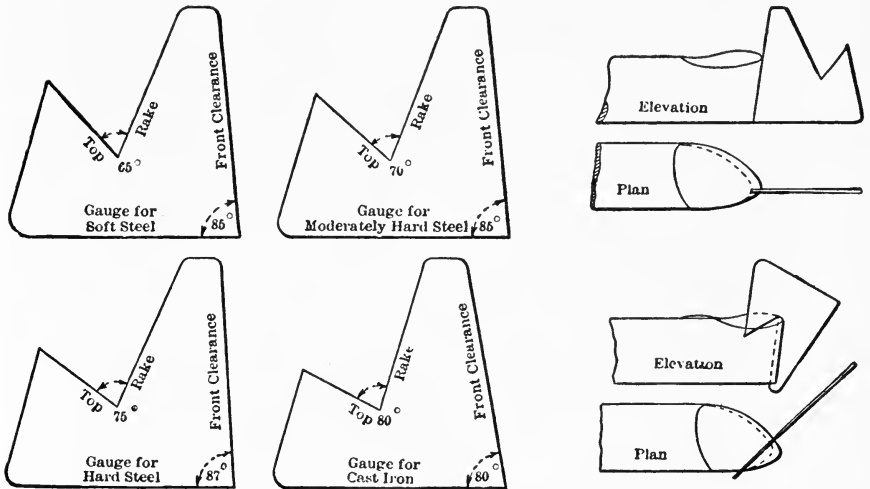

Fig. 58. Simple gage used for testing angles of English form of blunt-nose tool. Courtesy of Samuel Osborn & Co., Ltd.

wise the amount ground off will not be sufficient to remove all the burnt metal, and the tool will in that case work at a low efficiency until it has had several grindings. Many have noticed that, in their

own experience, tools seemed to improve with use, at least for some time after being set at work, particularly if the grindings were light. That is, after each grinding the tool seemed to last longer than before. Of course this is exactly what would be expected to happen when the tool has been insufficiently ground the first time. Each grinding removes more of the somewhat burnt outside portion, until the uninjured metal is reached and the tool works at its highest efficiency.

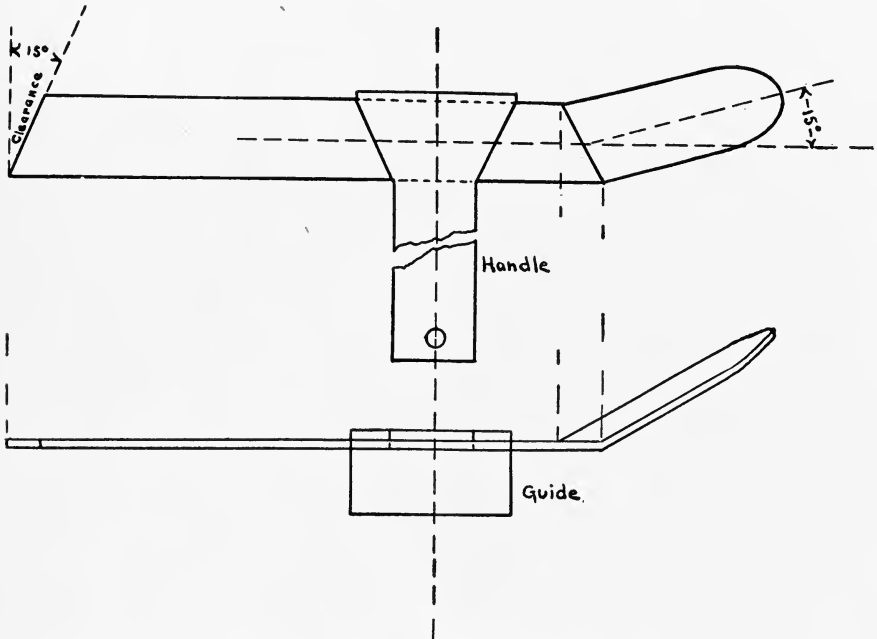

FIG. 59. Simple gage for standard roughing tool.

**Need for True Tool Bases.**—It must be remembered that the tools now under consideration, mostly lathe and similar forms, are subjected to tremendous strains, and that they must on that account be held very firmly in position. For this reason, it is necessary that the side upon which such a tool rests in the post or holder shall be smooth and true, so that it shall be firmly supported. After hammering true on the anvil it is well also to grind the base.

**Guarding Against Strains—Re-annealing.**—If reasonable care has been exercised during the forging it is unlikely that strains will have been set up. It is well, nevertheless, to guard against the possibility of them by re-heating tools to a bright red, holding them at this heat for a short time, and then allowing them to cool slowly in air or in dry ashes. This is to be done before the hardening, and after the forging heat has gone down below a black. The partial annealing not only helps to remove possible strains, but softens tools so that they can be



ground with ease to their approximate shapes, or machined without difficulty, should this operation be necessary. It likewise anneals the neck or shank of a tool when this has for any reason been allowed to reach a high heat during the forging of the cutting portion.

**Grinding off Excess Metal.**—Excess of metal, beyond what is necessarily removed after hardening for reasons previously given, is best ground off immediately after forging or annealing as above, on a dry emery wheel. This may be done while the tool is still red hot, or at any subsequent time before hardening.

**Danger in Stamping High-Speed Tools.**—Attention has been directed to the possible results attending nicking and breaking off tools from the bar stock. It is unwise also to make any nicks or marks on a high-speed steel tool at any place where stresses are applied. All stampings or other marks, such as are customarily made for identification, should be put in places where cracks can do no harm. A mark or nick in high-speed steel acts very much as does a diamond scratch in a sheet of glass, and will, in a part of the tool subject to strains, often eventuate in its ruin. Even when placed where no harm apparently can come, it is advisable that the marks be no deeper than necessary to serve their purpose.

**Forging vs. Machining Tools.**—It may be well to observe here that no tool should be forged which can, without prohibitive expense, be machined from stock. This generalization practically limits forging to lathe and other tools of similar form, made from the solid stock. Tools like punches may seem easily forged; but their tendency to burst, even when carefully forged, is a sufficient reason for turning down from stock rather than forging them.

## CHAPTER VII.

### HARDENING—THE HIGH HEAT TREATMENT PRACTICALLY APPLIED.

**Uncertain Results—“Over-Refinement.”**—As in forging, so in hardening, very crude apparatus can be utilized, sometimes with satisfactory results. For the hardening of an occasional tool only, it might be admissible to use the protected forge fire already described. But there would be no certainty in the results. A tool might, or might not, come out right. The only safe course is to use a properly designed furnace. If any considerable number of tools are used, a suitable equipment is indispensable if it is really desired to make tools which will exhibit the powers and advantages of high-speed steel to the fullest extent. The derision of over-refined methods, the feeling that tools “good enough” can be produced by common, crude methods, has no point. Over-refinement is of course possible, and the manufacture of tools can be made unnecessarily expensive. But it must not be forgotten that “good-enough” in the case of high-speed steel tools means, if it means anything, that the tool is *properly* made and treated, so that it works at its best and does not become in the end a very expensive tool by failing or by spoiling a lot of work. For all work where endurance and accuracy count for anything, that is to say, where tools need to be accurately sized and to stay so for the maximum time, as well as to work during a maximum period, refined appliances and methods represent money profitably invested.

**Oil and Coke Furnaces.**—The coke or anthracite furnace described and illustrated in the preceding chapter, Fig. 47, is well suited to hardening high-speed tools, as is that shown in Fig. 60, herewith. There are also many other suitable coke furnaces in use. When used for hardening heats, it is desirable that there be some arrangement for suspending the tools just above the fire bed, to keep them from contact with the fuel. A fire brick hearth or floor can easily be placed just above the fire bed, and this will be very convenient in doing some kinds of work.

The oil furnace is, in general, not suited to the hardening of high-speed tools. It is difficult to regulate the temperature or to keep it high enough; and ordinarily there is a good deal of oxidation. On finished tools this is particularly objectionable. The oxidizing action is in some cases partly obviated by the use of a baffle plate or a muffle;

and may indeed be wholly overcome by designing the furnace so that the tools are heated within a muffle or a crucible which in turn is raised

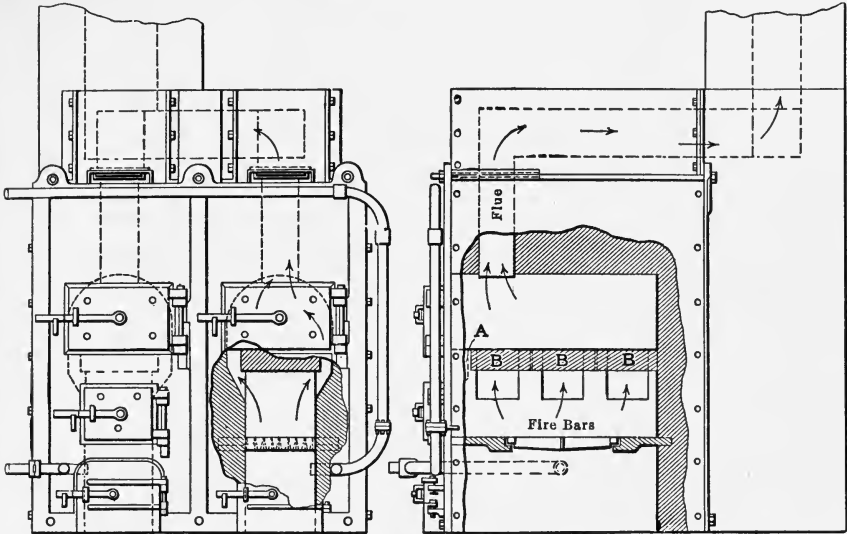

FIG. 60. A coke furnace used in hardening high-speed tools at the royal small-arms factory, Enfield Lock, England.



FIG. 61. Brayshaw twin-chambered hardening furnace, for oil or gas fuel. The illustration shows the furnace equipped for burning oil. The upper chamber is heated by waste heat from the lower, and is used for preheating.

to a white heat by the rotating flames in the fire chamber. The flames must not be directed against the crucible, either in such an oil furnace

nor in a similarly designed gas furnace, else holes are likely to be melted into the pot. An English furnace, Fig. 61, in which the flame is directed downward, toward the floor of the fire chamber, is claimed

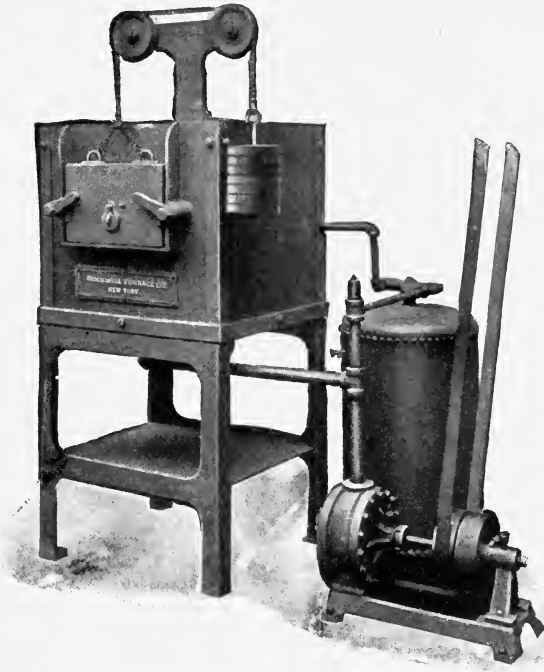

FIG. 62. Rockwell oil-burning furnace, complete with tank and blower. A self-contained outfit especially adapted to isolated duty.

to be quite satisfactory; and at least one American furnace, Fig. 62, is claimed to have overcome the difficulties and to be well suited to this use.

**Gas the Ideal Fuel.**—There is some diversity of opinion as to just which kind of fuel is best for high-speed steel heating, some maintaining that coke is not only ideal, but the only fuel which allows absolute control of temperature. On the other hand, the experience of others shows that gas furnaces are now made which will accomplish practically all that any coke furnace will do. This type is unquestionably the most convenient; and while it is true that the first cost of gas seems high, when everything is considered, it really is little if any more costly than other satisfactory fuels. The objection that in the gas furnace, as well as in others mentioned, oxidation of the tool takes place, has some foundation. It is true that, as often operated, the heating chamber of a gas furnace will contain more or less unconsumed air, and that some oxidation takes place as soon as the tools reach a high temperature, above a moderate red. Most of this, however, is unnecessary in

a properly designed and intelligently operated furnace, for the supply of air and gas will be so regulated that all the air will be consumed. The oxidation complained of not infrequently occurs because air currents enter the fire chamber through doors carelessly left open. Anyway, there is likely to be less of this scaling caused in the furnace than in the subsequent exposure in air-cooling, or in carrying to the quenching bath. With proper care all except those tools requiring the finest finish and the utmost precision can be hardened satisfactorily by using gas furnaces for the heating.

**Gas Manufacturing Plant.**—This type of furnace can be used even where a supply of gas is not available; for fuel gas manufacturing

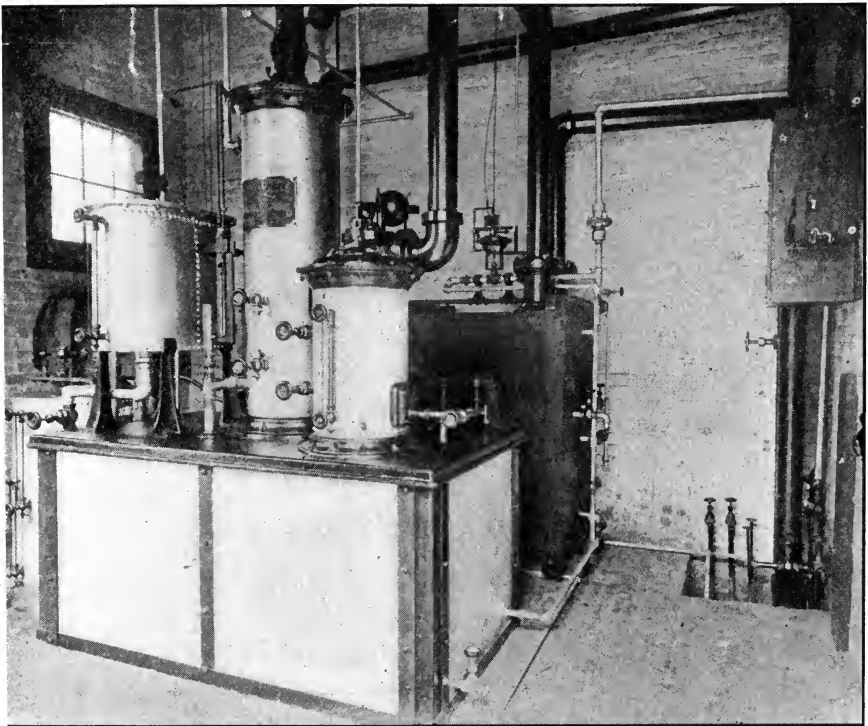

Fig. 63. An apparatus for producing gas from naphtha at a low cost. Desirable where gas is not available, or where the cost is excessively high. American Gas Furnace Co. installation.

plants in size suitable for supplying an equipment of gas furnaces are obtainable at a cost and with an economy of production which makes them desirable even where artificial gas may be had at the customary price. The cost of gas is, generally speaking, in this way reduced at least a half. In any event, the cost of the fuel is by no means the most important item in the making of high-speed tools; nor indeed is it of

great consequence in computing the net results. A single expensive tool spoiled for want of suitable facilities for hardening it, will pay for enough gas to heat a great many other tools. And with inadequate equipment many a tool is spoiled, or imperfectly hardened so that it falls below its maximum efficiency. Producer gas, it should be stated, has not been found well adapted to the production of such high temperatures as those required in hardening high-speed tools. Oil or coal gas is recommended.

**Gas Furnace Design.**—Excellent gas furnaces are obtainable at moderate cost, and it is not intended to discuss here their proper design

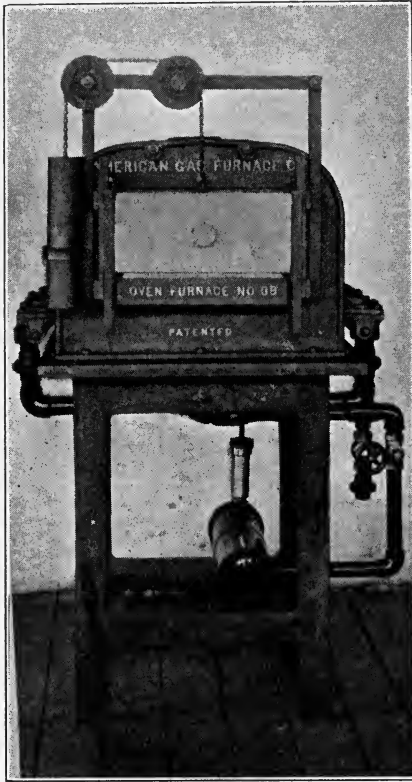

FIG. 64. An excellent type of gas-fired oven furnace. The flame impinges upon the under side of the floor upon which the tools rest.

further than to point out a few important considerations. A furnace should be of such form that the heating chamber can be, if required, entirely enclosed, to prevent radiation and fluctuation in temperature by entering air currents. The gas and air should be supplied to the fire chamber already mixed in proper proportion for complete combustion, and so directed that the heat falling upon the tools is for the most part that radiated from the fire-brick walls of the chamber or oven. It is desirable therefore that the flame be given a reverberatory movement by suitably curved walls or muffle plates in the heating chamber, or a rotative motion by a tangential arrangement of the burners or nozzles, so that it will be directed *past* rather than *toward* the center, where it would impinge directly upon the tool. The air supply must be at a pressure of between one-half and two pounds per square

inch, the air blast inducting the gas. Both air and gas supply must be under perfect control. These considerations hold in the case of forging and oil-tempering furnaces as well as with those used for hardening.

**Electric and Special Furnaces.**—More convenient than any other type of furnace, and more easily regulated, is the electrically heated; and this is coming into considerable use, especially for small work, testing,

and the like. Ordinarily the cost of electrical energy, in the operation of a large hardening plant, runs rather high.

For special forms of tools, specially adapted furnaces are desirable. For long and slender tools, like taps, drill, reamers, and the like, which are

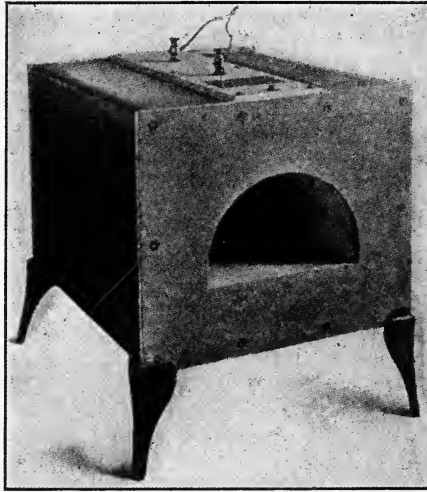

FIG. 65. An electrically-heated furnace for hardening small and medium-sized pieces.

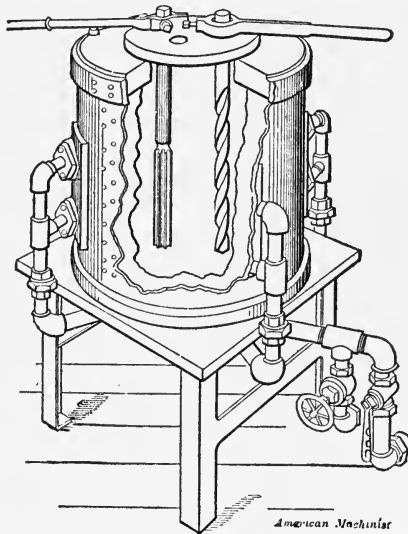

FIG. 66. A vertical gas furnace for heating slender tools suspended by their shanks.  
Courtesy of American Gas Furnace Co.

best hardened suspended from the shank, a cylindrical or rectangular vertical furnace is much better than an oven furnace. A modification of this form is suitable also for hardening in an empty crucible, as is

sometimes done. It resembles, in its general features, the oil crucible furnace already described and is identical with that shown at Fig. 83 in the chapter dealing with the barium process. Other special forms also can be used to advantage where enough work is done to warrant their installation. Such is a special die-hardening furnace, which is designed to harden only the face of a large die. Oil-tempering and other



FIG. 67. Stewart cylindrical (gas-fired) crucible furnace, Chicago Flexible Shaft Co.

furnaces for relieving hardness or strains also are essential to a well equipped hardening plant. These will be described in another place.

The type of furnace to be used will, as may have been inferred, depend a good deal upon the kind of tool to be hardened, so that it is desirable to equip a hardening room with two or three different forms to meet the varied requirements. There will also be other appliances such as those for quenching, for example.

**Minimum Hardening Equipment.**—The minimum equipment to be considered will include a combined forging and hardening furnace, of any of the kinds already described; and an oil-quenching bath, or a stream of air under slight pressure. The apparatus for air-cooling may be of the crudest form — nothing more than a pipe of any desired size (not too small, say not under  $\frac{3}{4}$  inch), leading from the air supply and provided with a suitable cut-off, or pressure-reducing valve, if compressed air is used. Occasionally tools can be hardened with no cooling apparatus whatever, merely being laid in a cool place, preferably where there is a current of moving air. This however, is taking long chances on tools, for no certain results can be expected under such crude conditions.



**A Moderately Complete Outfit.**—A fairly complete outfit consists of a forge, an oven, hardening furnace, an oil hardening bath or air-cooling table, and an oil-tempering furnace. Both the latter are described in the paragraphs indicating their use. A well equipped shop for forging and treating high-speed steel tools, however, would contain the following:

(a) A forge of suitable size for ordinary work. Its use has been already indicated.

(b) A medium (or large, according to the work to be done) oven furnace for the hardening heats. The small oven furnace or forge would

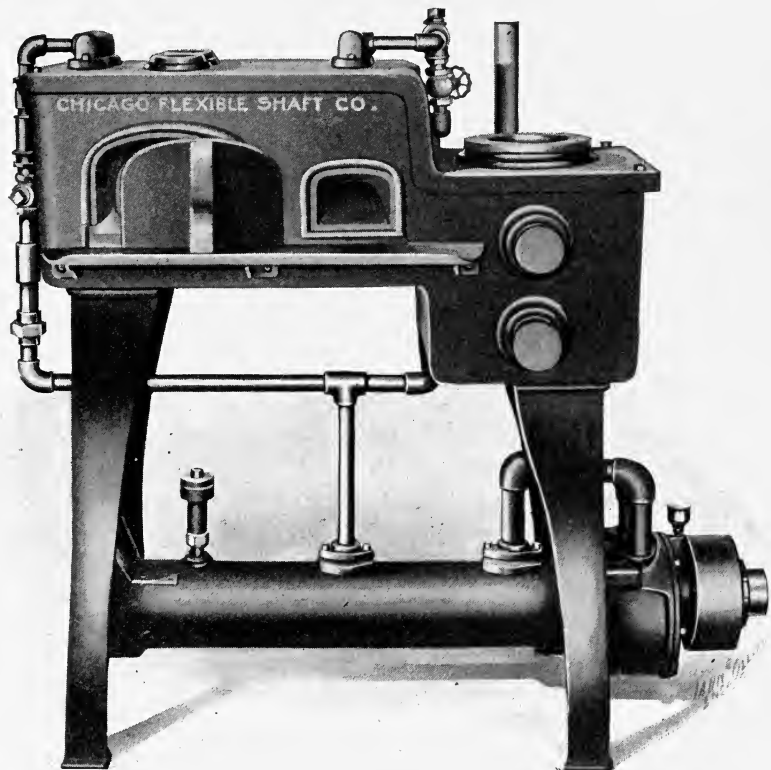

FIG. 68. Stewart combination gas furnace, with lead bath.

be used occasionally, no doubt, for small pieces. This furnace could be used also for what annealing would be necessary in most hardening plants. It would, along with the forge, serve for pre-heating in connection with the barium bath and crucible furnace, as well as with the customary methods of hardening.

(c) A cylindrical or rectangular vertical furnace of the kind already described, for heating long, slender tools which are best suspended from one end while being heated. If necessary, for the sake of economy,

this furnace could be easily adapted so as to be suitable, when provided with a crucible for that purpose, for hardening in barium chloride, or for hardening in a crucible without a bath.

(d) A lead bath is very useful where there is a wide range of work, but is not essential in high-speed tool hardening, especially if a barium furnace or a crucible furnace using no bath is adopted. A convenient and economical arrangement is a lead bath on the same base with a forge and oven furnace, as shown at Fig. 68. This economizes space and is very convenient.

(e) A cylindrical crucible furnace used without a bath. This is less convenient than an oven furnace, but is used in some plants because it practically prevents oxidation of fine tools while being heated. It does not, however, prevent oxidation, to some extent, when the tool is exposed to the air before or during cooling; and for that reason, among others, it is less desirable than the barium bath furnace. The lead bath, barium bath, and empty crucible furnace all can be so made as to utilize the cylindrical furnace body by interchangeable crucibles. It is of course more convenient to have a furnace of each kind likely to be much used in doing the sort of work in hand. In that case, this crucible furnace will likely be omitted, unless it is the intention to heat tools by this method as a regular practice.

(f) An oil tempering furnace for "drawing" the temper of such tools as require this to be done after hardening. This is described in a later chapter.

(g) A quenching bath or air cooling device. A very simple affair for cooling with air has been already referred to, which is quite good enough for rough tools of the simpler sort. For careful work a hardening table is desirable, and one suitable for this purpose is described in connection with the methods of cooling, as likewise is an oil quenching bath.

**Need for a Temperature Gage.**—A pyrometer for gaging the temperature and checking against the operator's judgment frequently, is essential to continuous good results. The novice, especially in the manipulation of the new steels, needs the guidance of such an instrument; and the experienced operator himself cannot afford to get along without it, especially when working with the barium or other bath process. For the latter, a pyrometer of the thermopile or the resistance type is generally used; while with the direct heating processes either of these, or a radiation pyrometer of the Fery type, can be used. It is well to have the fire ends (where this type of pyrometer is used) interchangeable on the different furnaces, or with a separate set for each, any one of which may be switched into the circuit with the indicator or recorder, whichever may be preferred.

Pyrometers which will give uninterrupted good service under the intense temperatures to which they are subjected in this kind of work,

are not easily obtainable. The fire ends break after being used but a few times; enclosing porcelain tubes crack and crumble; or the thermocouples deteriorate and cease to work properly. In any of these cases the indicator or recorder of course does not register correctly, and therefore is of small use, if indeed it does not mislead. When the fire end is suspected, it is well to check it with another pyrometer of known accuracy, or with clay temperature determining cones, sometimes called sentinel pyrometers. These latter are very convenient also in the absence of a pyrometer, to determine high temperatures. They are cheap, accurate and are obtainable in large variety. Each cone is numbered for identification, and melts down or fuses when the predetermined temperature has been reached which the particular cone was intended to indicate. The cones obviously are not available for determining the temperature of a molten substance, as in the case of the barium or lead bath.

**Supplemental Equipment.**—If any forging is done in the hardening room, even though not regularly, there will be also an anvil and the tools usually accompanying the same. The anvil illustrated in the previous chapter, in connection with the forging of a Taylor standard tool, is very convenient.

There should be provided also a suitable variety of tongs and other appliances for handling the tools, some of course of the conventional forms used for the purpose, and others especially adapted to the handling of tools requiring to be heated all over or which for other reasons cannot well be handled by ordinary tongs. The jaws of ordinary tongs, covering as they do a more or less considerable portion of the surface of the tool in hand, affect the temperature of the parts so covered and likewise prevent their coming into free contact with the oil or air in cooling. The excellence of the tool is thus impaired, often to a considerable extent. Many failures to secure results with high-speed steel, to say nothing of ordinary tools, are unquestionably due to so apparently small a thing as this.

‡ In some instances tongs with in-curving ends, properly formed to grasp the tools, are useful; in others the jaws may be studded with projecting hobs or prongs so that but a small amount of relatively cold metal touches the tool. Various desirable forms will doubtless suggest themselves as the occasion arises for their use.

**Arrangement of Hardening Room.**—The arrangement of the various furnaces and baths will depend much upon the number to be installed, and the limitations of the hardening plant — among other things, whether or not carbon steel tools, or even other objects, are to be hardened also. Assuming that a hardening plant for high-speed tools only is contemplated, and is equipped with the appliances enumerated above, the arrangement would be somewhat like that shown in Fig. 69. At

the extreme end would be the forge, and opposite it the anvil; next the small hardening furnace, if there be one, and the medium or large oven furnace; and beyond them the cylindrical and the barium furnace. Opposite these is the best place for the air table and oil bath, or either, if but one is to be used. On the same side with the quenching appliances and ranged at one side of them, are the lead bath, if there be one, and the oil tempering furnace. It is seen that this arrangement economizes space and practically centers the furnaces about the air table and quenching bath. The circular arrangement is avoided, though it is rather more convenient, because the space in which the operator works will doubtless be found quite hot enough without having focused upon

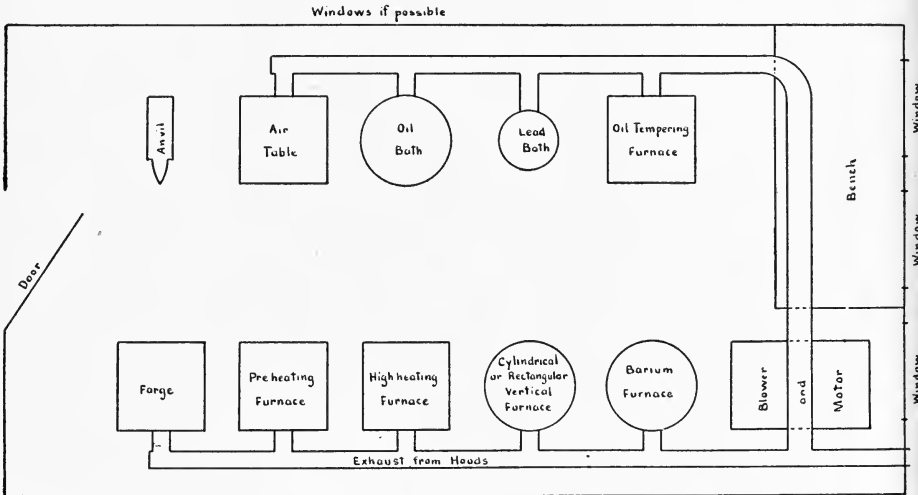

Fig. 69. Layout of hardening room of capacity sufficient for hardening all the tools used in a large manufacturing plant.

him the radiation of all the furnaces which happen to be in use at one time. If coke furnaces are used, the arrangement would be different only to the extent that these replace the gas furnaces here contemplated. There would perhaps be fewer of them, but each would occupy more space.

**Provision for Ventilating.**—Each furnace and bath should be provided with a hood, preferably telescoping so as to permit lowering or raising as occasion may require, to carry away fumes, smoke, and excess heat. It is desirable that the hoods be connected to a common vent which is exhausted by a fan. This will not only keep the room free of fumes, but will add greatly to the comfort of the operator by creating a cooling draft. The fumes from the lead bath at the high temperatures to which it is necessarily raised, and from the barium bath also under certain conditions, are very irritating and must not be allowed in the room. It is well also to jacket the furnaces.

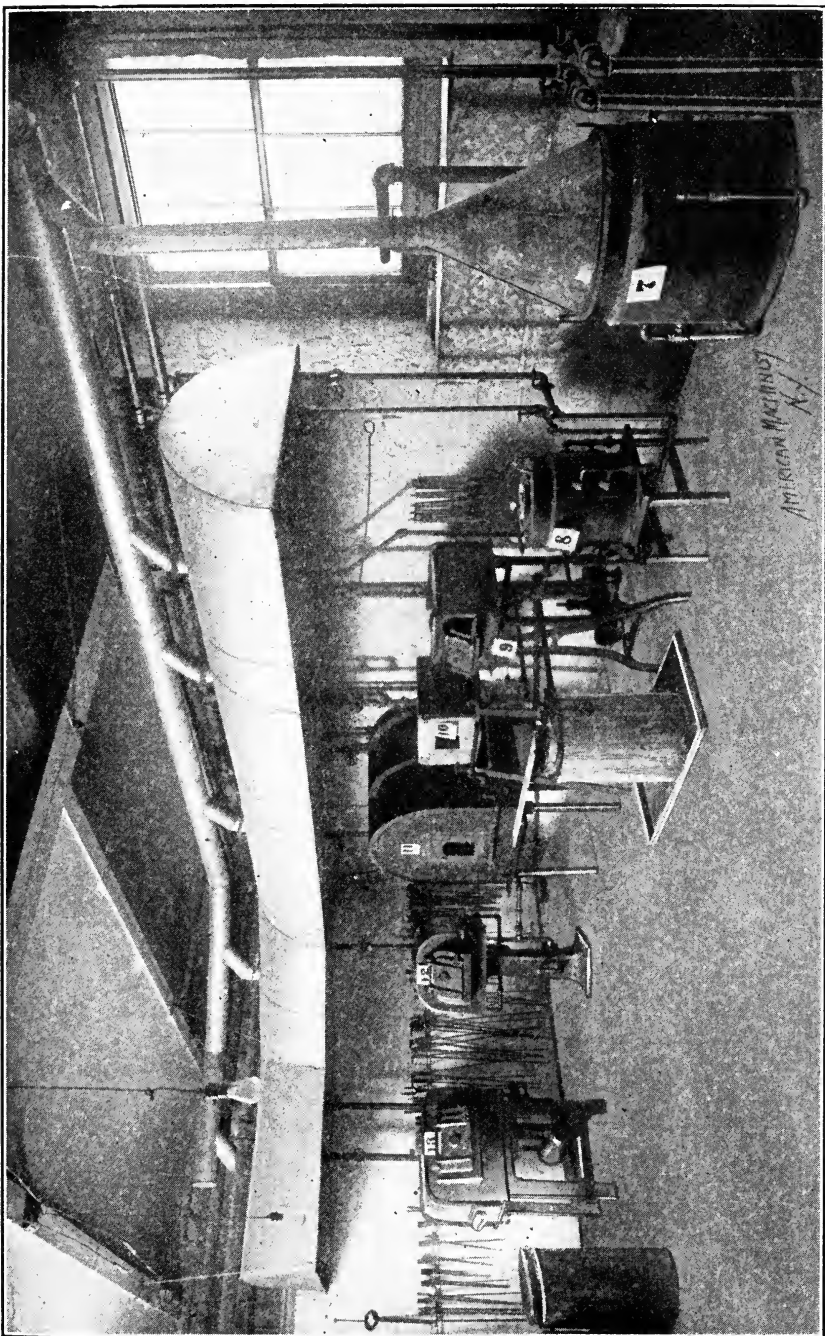

FIG. 70. A well equipped and arranged hardening room.

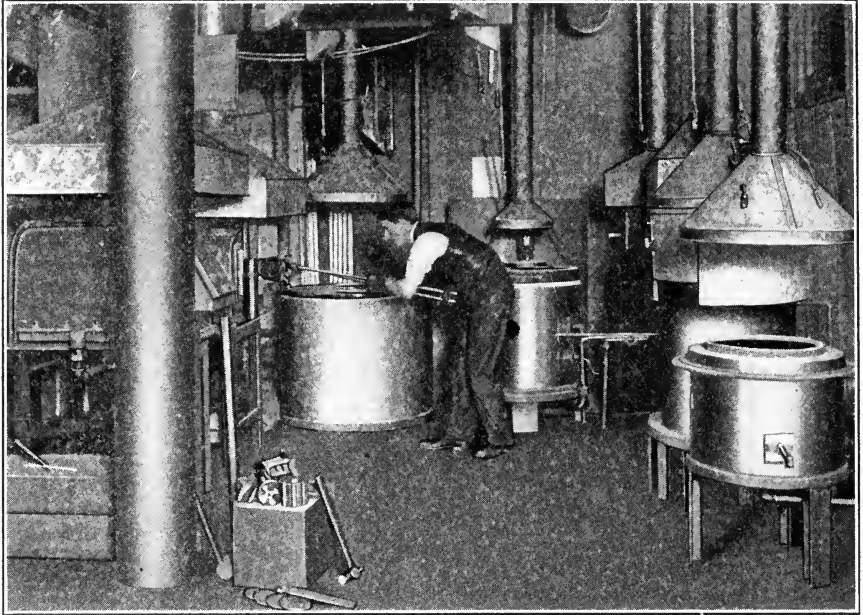

FIG. 71. "Each furnace and bath should be provided with a hood, properly connected to an exhaust." Individual hoods, one for each furnace, are to be preferred.

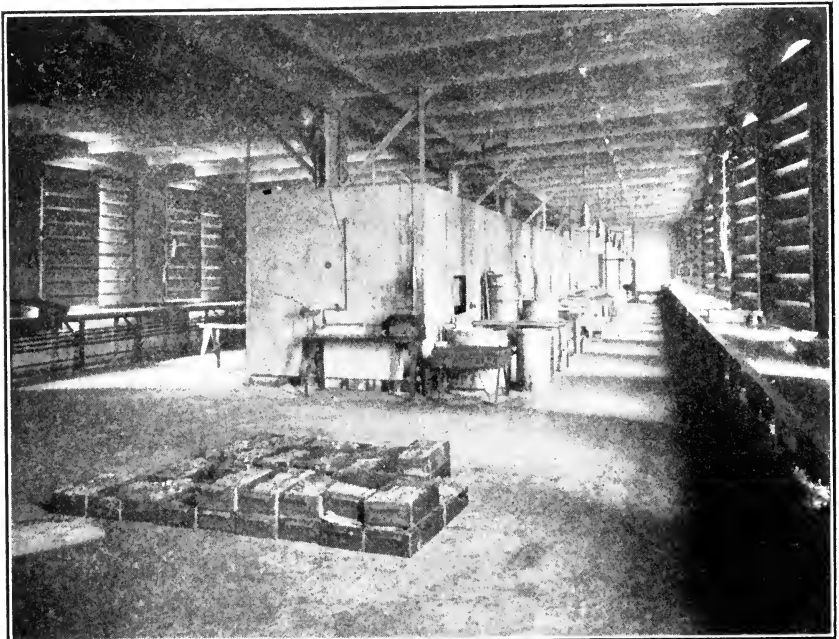

FIG. 72. Hardening room, Standard Tool Company, Cleveland. The furnaces are surrounded by a continuous sheet-metal jacket to prevent the distribution of heat into the room. Light is made even by the baffle shutters.

**Heating Simple Tools.**—Heating high-speed tools for hardening is a very different thing from heating them for forging, not only with respect to the temperature, but to the variation in method also. The way in which a tool is heated and quenched, in hardening, depends very much upon its form and the use to which it is to be put.

Lathe, planer, slotting, boring and the like tools can for the most part be readily ground to shape after hardening, and are on that account the simplest to treat. The heating may be done in any of the furnaces already designated as suitable for the purpose. It has been done successfully also in an ordinary smith's forge, though as already pointed out this method is not reliable and is undoubtedly responsible for many disappointments and failures. If no better means of heating are at hand, the forge fire should be covered with a hood, as already described in the chapter on forging, and the bricks well heated before any tools are placed in the fire.

**Gradual Heating Required.**—When using a fire of this kind, or a coke furnace alone, it is well to place a number of tools toward the edges of the fire or upon the ample foreplate provided for that purpose in the case of the coke furnace, bringing each in turn nearer to the hottest part of the fire. This allows of slowly bringing the temperature up to a bright red, about 1,000 degrees C. (1,800 F.). When this heat has been reached the tool may then be rapidly brought to a dazzling white, anywhere above 1,200 degrees C. (2,200 F.), so the surface begins to flux and the corners and edges show signs of melting down. A few steels will harden properly somewhat below this temperature, and it is well to note and follow the directions of the makers on this point. There need be no fear of overheating, for as a rule no good high-speed steel is injured by any heat to which it can be subjected in any fire such as has been here described.

**Time and Extent of Heating.**

—The time required for bringing a tool from the red to the white heat will of course vary with the size of the tool and the intensity of the heat. Under good conditions it should not need to take more than two minutes for a one-inch tool.

It is important that the heat soak into the interior of the nose or working part so that it is uniformly hot throughout; and that while the whole

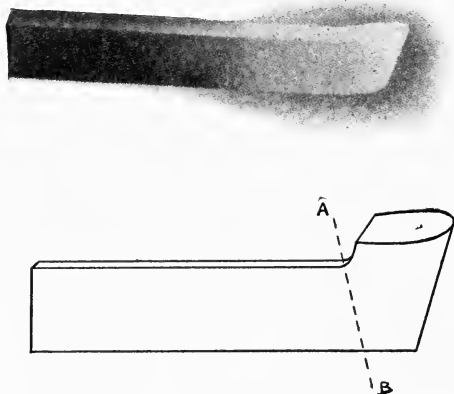

FIG. 73. The first tool has been heated rather farther back than necessary. The line *AB* indicates approximately the extent to which the tool should be thoroughly heated.

of the nose is so heated, the heat shall not soak up into the neck of the tool. The white heat should not pass beyond the line *AB*, shown in Fig. 73. It is to be noted also that some makers of these steels recommend that the heating be gradual from the cold to the intensest white. This, however, does not seem to be really necessary, and it is usually more convenient to heat, in the way indicated above slowly to a red and rapidly afterward to a dazzling white.

**Using the Gas Furnace.**—If a gas furnace is used to give the hardening heat, rather more care must be taken to keep the white heat in the nose of the tool. It is on that account desirable that tools of this kind be suspended through an opening in the top of the furnace, so the extent of the heating can be controlled as closely as necessary by the distance to which they protrude into the heating chamber. It is desirable that the first or slow heat be given in a pre-heating furnace, the temperature of which is kept at or near a red heat, say about 700 or 800 degrees C. (1,300 to 1,500 F.). The tools are transferred to the high-heat furnace as rapidly as they can be handled conveniently. This serves the double purpose of preventing, in the case of large tools, the sudden lowering of the high temperature in the hardening furnace and the consequent need for regulating it again, and the blistering effect upon the surface of tools thrust cold into a furnace at white heat. Not only is the surface blistered under these circumstances, but the outside of the tool heats so rapidly that corners will be melted down and the tool will have the appearance of being ready for cooling when as a matter of fact the interior probably has not nearly reached the required temperature. A tool hardened in this way very naturally would be defective.

**Grinding to Shape before Hardening.**—In order to avoid excessive grinding of the hardened tool, it should be brought pretty closely to the required shape on a dry emery wheel after cooling down from the forging heat and before being subjected to the hardening heat. Some allowance must of course be made for the grinding subsequent to the hardening, to remove the burnt skin and restore the cutting edge.

**Precautions Necessary.**—All tools with projecting edges, grained surfaces, sharp angles, or many clearances, are peculiarly susceptible to cracking during and after hardening unless this has been carefully and properly done. It is evident, therefore, that all possible precautions should be taken, by the use not only of care and intelligence in the treatment, but of adequate and approved special appliances whenever these have been shown by experience to help bring the best results. The need for certain special hardening furnaces indicated in a previous paragraph is made very evident when tools of the classes just mentioned are to be hardened.

**Suspending Slender Tools.**—Such tools as long taps, reamers, drills, and the like, especially when slender, are very liable to warping and bending, unless heated (and cooled also) in a vertical position. They



should therefore be suspended by their shanks during the heating. A vertical furnace such as has been already described, and illustrated in Fig. 66, is desirable for this purpose, though a coke furnace could have its top suitably arranged to allow of the same thing. The shanks of the tools project through holes in the cover of the furnace and they are held in place by tongs or holders provided for that purpose. The pre-heating can be carried on in any convenient way.

**Temperature Limits.**—The temperature is not carried as high as in the case of tools which can be ground after hardening, and must always be short of the point where the cutting edges begin to melt. The limit of temperature is about 1,250 degrees C. (2,300 F.) except for heavy roughing cutters, when it is 50 to 100 Centigrade degrees higher, and may range downward to a hundred degrees below that point, or from a mellow white or light straw to a bright lemon or very light orange color. Where the tools are of such a kind that the cutting edge can conveniently be re-ground after hardening, the heat may be carried up to that generally given to forged tools, or a little above 1,300 degrees C. (2,400 F.). Tools for most kinds of work are the better for this, if they will allow of the higher heat. The tools must not be allowed to touch the fuel nor be exposed to a flame after reaching a yellow heat, lest the cutting edges be injured. It must be remembered that, as in the hardening of all high-speed tools (except as pointed out in the chapter dealing with the barium process), the heating must proceed evenly throughout the tool or throughout that part which is to be hardened. Otherwise, strains are sure to be set up during the cooling, which are not relieved by the ordinary methods of tempering even, and which inevitably affect the endurance of the tool. All tools of intricate shape are peculiarly susceptible to cracking from such strains, the defects frequently appearing long after the tools have been set at work, if not immediately after the cooling.

**Watch the Pyrometer Indicator.**—Success in hardening these tools depends very largely in getting just the right temperature in the heating. It is very necessary, therefore, to watch carefully the progress of the heating when the color begins to verge on a light yellow, so that the cutting edges shall not be damaged and a crust formed which would afterward need grinding off and thus affect the size of the tool. It is well to consult the pyrometer frequently at this point, for the varying conditions of light on different days and even in different parts of the same day are quite enough to affect the judgment of the operator.

**Milling Cutters and Like Tools.**—Milling cutters and similar formed tools are heated in practically the same way as are tools of the kind just considered, except that the cylindrical furnace is not used. It is no better than the oven furnace for these tools, if as good. The cutting teeth or edges must however be kept from contact with fuel or furnace

walls and floors, and it is well therefore to set such tools on end upon pieces of fire brick of appropriate size, or to suspend them from above by a suitable arrangement.

Unless this precaution is taken the keenness of the edges is almost sure to be impaired, if indeed the hardening also be not affected. For the same reasons, more especially because the proper hardening is sure to be affected, in handling tools of this sort, tongs or other appliances must be used which will not touch the cutting edges.

If such tools are of necessity heated in a forge fire, they should be, like drills and reamers, frequently turned; and it is well to do this however they may be heated. The cutting edges must not be allowed, when at a yellow heat or above, to rub against the fuel; and it is better that they do not even come into contact with it. This is one of the reasons why a forge fire is not well suited to the hardening of fine tools. Another reason is the oxidation which inevitably takes place to a greater or less extent under such crude conditions.

**Oxidation and its Prevention.**—To protect such tools, heated under these conditions, from scaling and impairment of edges, a file-maker's paste, sometimes called a hardening paste, has been used by some. This however, while possibly serving the purpose desired to a considerable extent, leaves the surface of the tool unclean, so that the hardening is not infrequently affected.

The oxidation trouble is often very annoying, when it is not prevented, necessitating the re-grinding of tools after hardening and consequently also necessitating making them in the first place enough larger than the finished size to provide for this contingency. Except in the forge fire, oxidation need not occur to any considerable extent in any properly designed and intelligently operated furnace. Ordinarily most of the oxidation takes place after removal from the furnace and while the tool is exposed to the air. It is desirable therefore that tools be not carried, exposed to the air, any considerable distance for the cooling. This is imperative in the case of fine tools and those with sharp edges, unless they have been heated in the barium chloride bath.

**Lead Bath and Pack-Hardening.**—It is to prevent oxidation entirely that the lead bath, the empty crucible muffle furnace, and like means, have been resorted to. These will be further considered in connection with the barium process, in a separate chapter. The "pack-hardening" of fine tools serves its purpose quite effectively, but is now little practiced because the same results can be obtained by less troublesome means. Where adequate facilities for getting the same results in a quicker and more certain way are wanting the method<sup>8</sup> still serves a purpose. The usual practice is to enclose the cutters, if small, in a piece of wrought-iron pipe, packed closely with charcoal, fine coke, or other customary packing, with the ends of the pipe sealed with clay. If much of this sort

of work is to be done there should be a suitable pot, preferably of wrought iron. Cast iron will do, but it must be expected that the bottom will drop out occasionally, so intense is the heat required. Tools placed in the packing case should not touch one another, and, where this can be done conveniently, should be suspended by a common support before packing, to facilitate their subsequent removal and quenching (Fig. 74). The pot and contents, after sealing up, are placed in the white-hot furnace until the whole is at the uniform high heat necessary for hardening the particular kind of tools in hand. No rule can be laid down for the length of time required, since that will depend entirely upon the size of the tools and pot. The operator must be guided by experience — and the pyrometer. Some indications as to the condition of the tools may

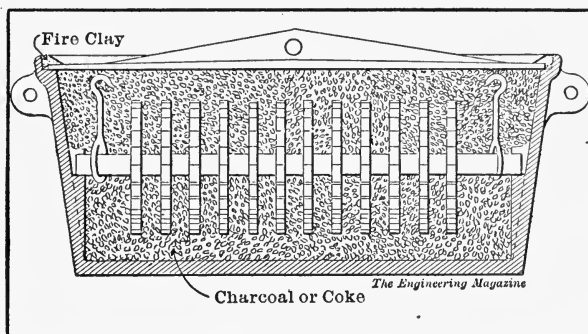

Fig. 74. Pot for "pack hardening" tools, with method of suspending cutters for convenient handling and avoidance of contact in quenching.

be obtained by the old expedient of withdrawing from time to time wires previously inserted in the pot for that purpose. The contents having reached the necessary temperature, the pot is withdrawn, and its contents removed and quenched as rapidly as possible.

**Causes of Scaling.**—It may be of interest to mention the causes of scaling or oxidation. The explanation is very simple. At high heats iron and oxygen (which latter constitutes about a fifth of the atmosphere) have a keen chemical affinity for each other, and the oxygen of the air attacks the hot iron (or steel) with great avidity. The resultant of their chemical combination is a scale constituted of iron oxide, which is the same as common red iron rust except that the latter contains some water while the former does not. Scaling takes place also when steel or iron is left in contact with fuel through which air is passing or with which air is mixed. Hence the need for the cautions previously given with reference to such contact.

**Special Methods.**—The need for exceeding care and the use of suitable appliances in the hardening of high speed steel tools, in order to insure proper and uniform hardening and to avoid deformation of their shape,

has been already referred to several times. Nevertheless its importance warrants still further mention of the matter, especially in connection with the use of gas or other furnaces with floors or hearths. Tools of compact shape can, when so heated, be placed directly upon the floor of the heating chamber, or preferably upon pieces of fire brick; and are removed in the ordinary manner, the tongs of course being suited to the purpose. Long and slender tools, and others which are likely to be deformed, may be laid upon bricks or bars which have been carefully leveled, and are removed by the aid of pronged bars or other suitable implements. To expedite the heating of many small tools, say like inserted cutter blades, they are laid upon parallel bars which in turn rest upon the floor of the furnace. A flat bar or suitably pronged rod can be used for placing or removing a whole row of them at once. In all these cases the implement used for handling the pieces is to be well heated up before lifting them out, for reasons already assigned.

**Punches, Shear Blades, etc.**—For hardening punches, punch dies, shear blades, forming dies, and a variety of other tools more or less like them in use, the heat is not brought as high, generally speaking, as for those classes of tools already considered. These tools preferably are ground closely to shape before being hardened. The temperature is in all cases kept below a clear white heat — say at a lemon color or near 1150 degrees C. (2100 F.). From this it may range downward, according to the brand of steel used and the size of the tool, to a very bright red, about 950 degrees C. (1750 F.). Small shear blades hardened at the higher temperature named give excellent service without being tempered. Chisels and other tools subjected to repeated shocks are taken at the lower temperature mentioned.

**Summary of Hardening Temperatures.**—For convenience of reference the temperatures required for hardening the various kinds of high-speed tools are here summarized. Turning, planing, shaping, slotting, boring, and the like tools for roughing and medium cuts: a full to a dazzling white, as high a temperature as can be given without actually melting the tools. Melting does not occur, in most high-speed steels, below 1400 degrees C. (2550 F.).

Milling cutters and similar tools for heavy roughing: a good white, 1300 or 1350 degrees C. (2375 to 2450 F.).

Milling cutters for moderately light and finishing cuts, forming cutters; screw machine tools, tools for fine finishing, and those which are to hold keen edges where the strain is not great, tools for cutting brass, and nearly all woodworking tools: a mellow white or light straw, or a little deeper, say from 1250 to 1200, or even 1150 degrees C. (2300, 2200, 2100 F.).

Twist and flat drills, reamers, threading dies and taps, and other tools subject to severe torsional strains: slightly lower than that given above, or say a little below 1200 degrees C. and down to about 1175 (2200

to 2150 F.) or slightly below. This would give a light lemon color, verging into straw. It will not greatly matter if these tools be heated quite as high as those in the class above, though in general rather better results will follow if this difference be observed.

Shear blades, punches and punch dies, stamping and forming dies, pneumatic tools and others subjected to repeated jars or blows: 950 to 1150 degrees C. (1750 to 1900 F.) or from a bright cherry red to a light orange or lemon, according to the shape and use of the tool. Light punches and snap dies would be given the lower heats, as also would tools like file-cutting chisels.

**Permissible Temperature Variations.**—It should be remembered in connection with the above summary that the hardening temperatures of high-speed steels vary more or less according to the composition, and that it is well to observe closely the instructions of the makers relative to this point, or better still to make careful determinations when any given steel is to be used, and thereafter to observe the limits found to be most satisfactory. In the nature of the case the above determinations are only general; but it is asserted with confidence that but little variation will be found desirable in the case of any high-speed steel of the now accepted standard composition — if it is not premature to speak of a standard composition.

**Quenching Agents—Water.**—For cooling high-speed tools either air or oil is used to good advantage. Cold water is, in general, to be avoided in cooling high-speed steels, whether of the so-called “new” varieties or not. Quenching in cold salt water is of course possible, and has in some cases been recommended by makers. Nevertheless hot high-speed steel and cold water are not a safe combination. A tool so cooled may not crack, and indeed may perhaps be repeatedly quenched in water — and again it may crack the first time, or strains may be set up which will cause cracks later. The uncertainty of the method, if nothing else, makes it a good thing to avoid except possibly in those cases where extreme hardness is requisite and the danger of cracking can be overlooked. Hot water, speaking in a general way, is less likely than cold to cause cracking, and has been used successfully for obtaining extreme hardness. It is best kept at a temperature rather above 70 degrees C. (160 F.). The novice will do well to let water alone as a quenching agent.

**Air Cooling.**—In the early days of high-speed steel air was recommended by most makers, to the exclusion of oil. It is coming to be pretty generally agreed now that if oil does not give better results, as some maintain, it at least does give quite as good as air, and that it has some advantages not possessed by the latter. Inasmuch as most high-speed steels harden by mere exposure to the air, little apparatus is absolutely required, as has been already noted. Some rather good results

have been obtained in this simple way. The hardness of these steels, however, depends a good deal upon the rapidity and the method of cooling, on which account mere exposure to the air does not bring out the qualities of the tools to anything like their highest degree. For many tools, therefore, this method is out of the question. To obtain uniformly good results the air should be cool and in motion. Preferably it is supplied in a continuous and rapid stream, large in volume rather than high in pressure. Compressed air is better than that from a blower. The pressure must, however, be reduced to two or three pounds only at the nozzle.

**Apparatus for Air Quenching.**—For hardening an occasional tool, as has been already indicated, nothing further is required than a supply of air coming from a suitable nozzle of ample size. The tool is held in the blast and turned continuously until cold enough to handle, when it is laid

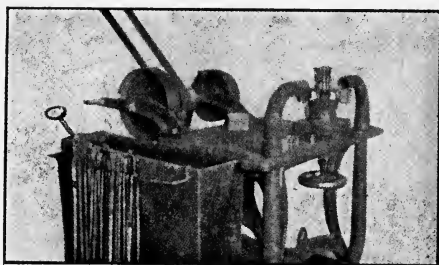

FIG. 75. Table for air-hardening revolving cutters, as used at the Royal Small-Arms Factory, Enfield Lock, England.

aside in a dry place. Where many tools are to be hardened, even if only of the simplest kind, it is very desirable that there be a cooling table where the tools can be mechanically held and turned while the air blast plays upon them. Such an arrangement is almost indispensable in the case of rotary cutters. A cooling table of simple design, used in the British Royal Small-Arms Factory at Enfield Lock, is shown in Fig. 75. It consists essentially of an iron-top table provided with a rotating plate and spindle between two movable nozzles from which the air blast issues. The spindle and plate can be provided with a clamp for holding lathe and similar tools also. In cooling milling cutters and the like, the nozzles are turned to one side of the center of the cutter so that the air will impinge upon the projecting teeth in such a way that they will act as vanes, and the cutter be therefore rapidly rotated by the air current. All cutting edges are in this way cooled with absolute uniformity. An air box, resembling that illustrated at Fig. 76, is desirable for cooling lathe and similar tools.

side in a dry place. Where many tools are to be hardened, even if only of the simplest kind, it is very desirable that there be a cooling table where the tools can be mechanically held and turned while the air blast plays upon them. Such an arrangement is almost indispensable in the case of rotary cutters. A cooling table of simple design, used in the British Royal Small-Arms Factory at Enfield

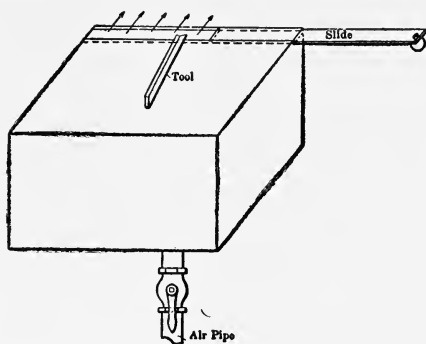

FIG. 76. Air box for air cooling of high-speed tools. Convenient for hardening lathe tools and those of similar shape.

is desirable for cooling lathe and similar tools.

The convenience and simplicity of this method of hardening certainly recommend it. There are, however, certain disadvantages. The cost of air, for one thing, is considerable, and not comparable with that of maintaining an oil bath. The first cost of the latter is also the last cost except for the negligible item of renewal. In the air blast, furthermore, in spite of the rapidity of the cooling and the exercise of the greatest care, there will frequently be more or less oxidation; and this is not permissible, in fine tools at any rate, affecting their precision as it does. Scaling is unimportant in the case of rough tools, since they are well ground anyway after hardening. Tools cooled in air are, in general, rather slightly softer than those cooled in oil.

#### Apparatus for Oil Quenching.—

For oil hardening the apparatus may be almost as simple as for air hardening. In small shops where but few tools are treated, nothing more is required than a medium sized tank full of oil. The shop doing a good deal of hardening, however, needs a bath of ample size equipped with some device for cooling and circulating the oil. An excellent form of such an apparatus is shown in Fig. 77. It is seen to consist of a sheet metal tank of suitable size, having a supply pipe and laterals at the bottom through which air under slight pressure is introduced. The pipes

have small holes in their upper sides from which the air bubbles up through the oil, at the same time cooling and circulating it. A net for catching tools accidentally dropped is desirable, as also is a net basket at one side, into which small tools may be thrown from time to time, for quenching, without further attention.

**Kind of Oil to Use.**—Various oils have been recommended for quenching high-speed steel, including linseed, cotton seed, rape, fish, whale, lard, tallow, paraffine, and even kerosene. It does not matter particularly, so far as the effect upon tools is concerned, which is used, as long as it is thin and does not become gummy. Some have certain disad-

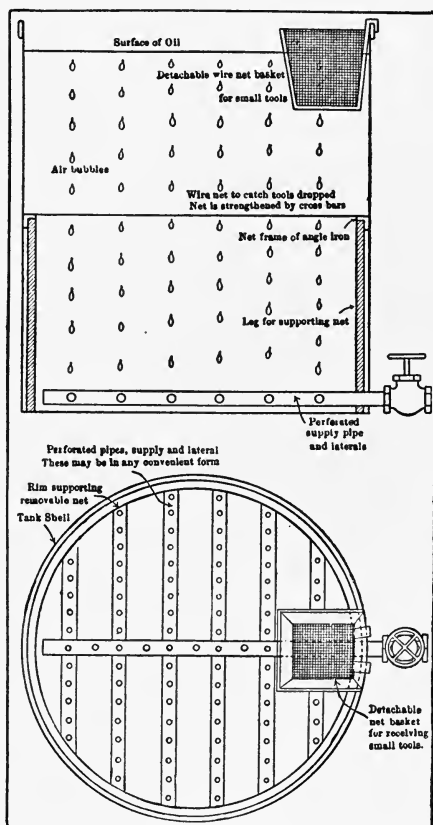

FIG. 77. Excellent design for oil-hardening bath.

vantages, though, which it is well to consider. Kerosene oil has given better satisfaction than anything else in some hardening plants. It does not flash, as might be expected, upon the hot tool coming in contact with the surface unless the quenching is very awkwardly done. If the tool is plunged quickly to a point below the heated portion, or entirely in the case of tools heated throughout, there will be no flashing.

**Disadvantages of Certain Oils.**—Whale and fish oil are excellent agents, but have offensive odors. These can easily be suppressed, however, by the addition of about three per cent of heavy (tempering) oil. This at first floats upon the surface, but usually mixes with the lighter oil in time. The hardening is not affected by the heavy oil added, and this combination is about as satisfactory as any could be.

Linseed oil is too gummy for general use. Lard oil becomes more or less rancid in time, but is excellent; and cotton seed oil has practically no objectionable features. The point is not so much what kind of oil is used; but that the supply be ample to absorb the heat rapidly from the tool. Where much hardening is done it is of course necessary, as already noted, to provide a means for stirring and cooling the oil.

**Cautions as to Quenching.**—The quenching itself seems, and indeed is, a simple matter. There are, however, some points that should be carefully observed, to get uniformly good results. First, the quenching must be done rapidly. Not only is the tool to be plunged into the oil with the least possible interval between this and the removal from the furnace, to avoid oxidation; but the plunging itself should be quickly done. Circular cutting tools, like milling cutters, are plunged with the axis vertical unless the thickness is considerably less than the diameter. In that case they are quenched like thin dies; that is, in an upright position. Most other tools can be plunged with the long axis vertical. After immersion the tool can of course be turned to any position that may be convenient. The vertical plunging obviates to the largest possible extent the warping and cracking to which intricate tools, and even those which are not intricate, if carelessly quenched, are subject. A thin, flat die with relatively large surface, for example, if quenched so that one face strikes the oil before the other, even if the intervening time be infinitesimal, almost invariably is warped and becomes useless.

**Special Case of Slender Tools.**—In the case of drills, reamers, and the like, the heating of course has not extended the full length of the fluted part (unless, as rarely happens, the whole length is intended to do work), and the quenching does not go beyond the heated portion, say not beyond where it is still a good red. This can well be laid down as a general rule: a tool, except as already indicated, should be plunged to a point rather nearer the edge or end than that to which it has been heated, and worked up and down slightly while cooling. In this way a distinct



line of demarkation between hardened and unhardened portions will be avoided, and the snapping of tools at this place prevented.

**Large or Intricate Tools.**—If of any considerable size the tool must be kept moving in the bath so that all parts immersed will be washed by cool oil, otherwise the oil in contact with the surface becomes so hot that hardening does not take place properly. This is especially true of tools of intricate shape, with many recesses, or containing small holes. In the last named case the tool should be so moved in the bath that oil will flow freely into and through the openings. If several tools are quenched simultaneously care should be taken that they do not touch one another, lest the places touching fail to come into free contact with the oil and consequently do not harden properly.

**Essentials of the Hardening Method.**—The method of hardening here described involves essentially this: The tool is heated to the highest temperature it will bear without injury to the cutting edge, and even to the melting point if it can be afterwards well ground. It is then quickly cooled in an air blast or in an oil bath. This process is simpler than that patented by Taylor and White, is much more used, and is quite generally conceded to give results equally good with practically all standard high-speed steels.

**Essentials of the Taylor-White Process.**—The Taylor-White process consists in the following steps:

First, the high-heat treatment. The tool is heated to the highest temperature it will bear, as in the general process already described. It is then cooled rapidly down to the "breaking down" point, about 850 degrees C. (1550 F.), and after this cooled more or less slowly, as may be convenient. The method recommended by the patentees, for the preliminary cooling, is to plunge the tools from the high heat into a lead bath maintained at a constant temperature of 625 degrees C. (1150 F.), and to hold them there until they have had time to reach that temperature throughout their entire mass. Mr. Taylor says<sup>1</sup> it is a matter of no particular importance whether the tool be cooled rapidly or slowly below the "breaking down" point; and indicates that it may just as well be cooled in the air blast as not, and does quite well if merely laid aside to cool in the normal atmosphere.

Second, the low-heat treatment. The tool is reheated to somewhere between 375 and 675, say to approximately 625 degrees C. (1150 F.), preferably in a lead bath large enough to maintain a uniform temperature. The tool is kept at this temperature for about five minutes, and is then cooled, whether rapidly or slowly being a matter of indifference.

**Taylor-White and Other Methods.**—The only essential difference between the Taylor-White and the customary process is seen to be in the

<sup>1</sup> See Appendix B.

second or low-heat treatment, which is omitted in ordinary practice. In another place mention is made that high-speed tools do not run at their best until a short time after being set at work, after being "warmed up," so to speak. The warming up is not figurative, but real. The tool soon attains a temperature approximating the minimum above given, that is, 375 degrees C., and therefore accomplishes while at work what is intended to be accomplished by the low-heat treatment. The "self-treatment" thus received by a tool does not normally give so high a temperature as that recommended by Mr. Taylor, unless run so rapidly that the cutting edge becomes red hot — which is not good practice, generally speaking. The cooling naturally occurs when the tool is stopped preparatory to taking the next cut. Apparently, therefore, the second or low-heat treatment is superfluous. It is maintained, nevertheless, that the self-treatment just referred to does not accomplish to the same extent what the low-heat treatment does, the temperature to which the tool is raised being rather too low under ordinary circumstances. However that may be, the second treatment is all but universally dispensed with, and so far as can be seen without disadvantage.

**Special Modifications.**—A modification of the Taylor-White high-heat part of the treatment is sometimes recommended by the makers of particular brands of high-speed steel. The tool, after being brought to the requisite high heat, is transferred to a hot bath of some kind, whether lead, fusible salts, or the like, where it is cooled to a dull red, equivalent to a temperature near 675 degrees C. (1250 F.), or 690 degrees C. (1280 F.), according to one successful maker of many tools. It is then removed from the bath and allowed to cool naturally, or it may be rapidly cooled in an air blast or by quenching in oil. Mr. Gledhill recommends a still further modification, cooling to the point mentioned above or slightly higher, in the air or in a blast, and then quenching in oil. As a matter of fact it would seem that the manner of cooling is relatively of small consequence, except that if it be rather rapid in the first stage the result will be a somewhat better tool. But the high heat is absolutely essential; and the higher the heat, the better the tool — subject, of course, to the limitations already pointed out.

**Electrical Hardening.**—High-speed tools may be hardened electrically, though the process has not come into very general use. No definite information is at hand as to the excellence of the tools so treated, though the results are said to be satisfactory. Two methods have been practiced to some extent.

In the first method, illustrated in Fig. 78, the tool forms the positive electrode of an electric circuit in which it is placed by being clamped in a suitable clip or holder. The other electrode is constituted of the walls of a cast-iron tank containing a strong solution of potassium car-

bonate. There are, of course, the necessary fuses, switches, and current regulators. The current having been turned on, the tool is gently lowered into the solution to the depth to which it is to be hardened,

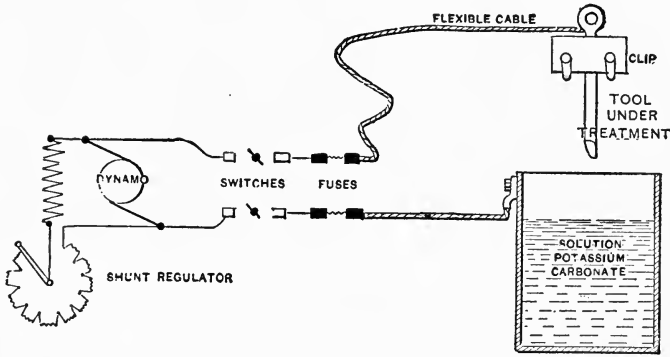

Fig. 78. Arrangement of apparatus for hardening tools electrically by use of potassium carbonate bath.

and moved up and down a little so as to avoid an abrupt transition from hardened to unhardened part. The tool on entering the bath completes

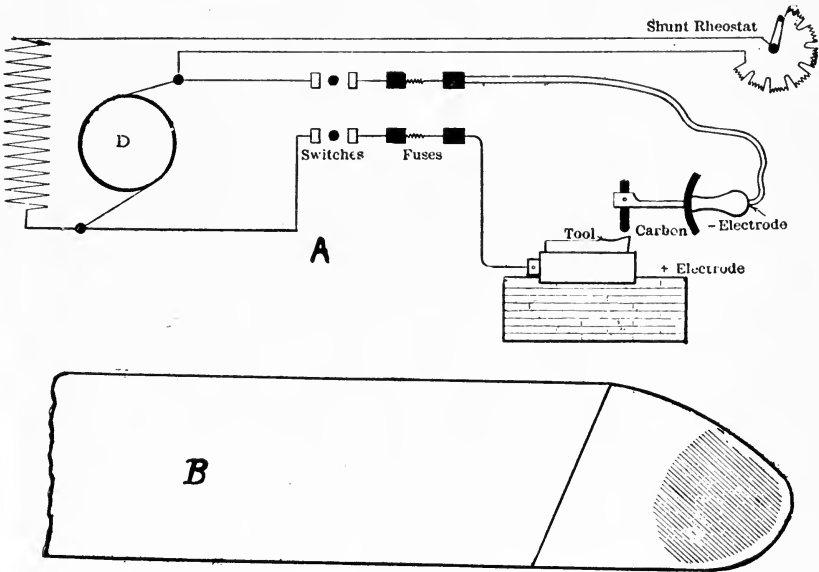

Fig. 79. Arrangement of apparatus for hardening electrically by use of the electric arc. The shaded portion in B indicates the location of the carbon point during the heating. The cooling is by air blast or oil bath, as in the ordinary method.

the electric circuit, and an intense heat is set up in the part immersed. When this is seen to be sufficiently heated, the current is switched off and the tool allowed to cool in the solution as though in an oil bath.

In the second method (Fig. 79) the electric arc is utilized. The tool is placed on an insulating block and attached to the positive electrode. The other electrode is a stick of carbon clamped in a safety holder. The current being on, at a low voltage, the carbon is touched to the part of the tool to be hardened, and moved about as desired until the required heat has been attained, the voltage being gradually increased through a suitable rheostat. The tool is then cooled in the customary manner. This method evidently is suited only to local hardening, and not to the general run of tools.

## CHAPTER VIII.

### HARDENING—THE BARIUM CHLORIDE PROCESS.<sup>1</sup>

**Preventing Oxidation.**—The scaling or oxidizing of fine tools has been already referred to as troublesome in certain cases; and ways have been



FIG. 80. A cylindrical gas furnace fitted for use with the barium chloride process. Crucible filled with melted salts and ready for use.

<sup>1</sup> While the hardening of high-speed steel by the barium process was originated in Europe, it seems not to have been made commercially practicable until it was taken up in this country by the agents of the Firth-Sterling Steel Company (Wheelock, Lovejoy & Co. in New York and Boston, and E. S. Jackman & Co. in Chicago) and per-

pointed out by which this annoyance, and the attendant expense of re-finishing, could be minimized with such appliances as might reasonably be expected to form part of a moderately well equipped hardening plant. Even before the days of high-speed steel it was felt that there should be some means of entirely obviating the nuisance; and many methods have been devised to that end, a number of them entirely successful except for one thing. The coke furnace, the well-regulated gas furnace, and possibly other ordinary furnaces give, as already remarked, very satisfactory results except as to tools requiring a fine finish; and the

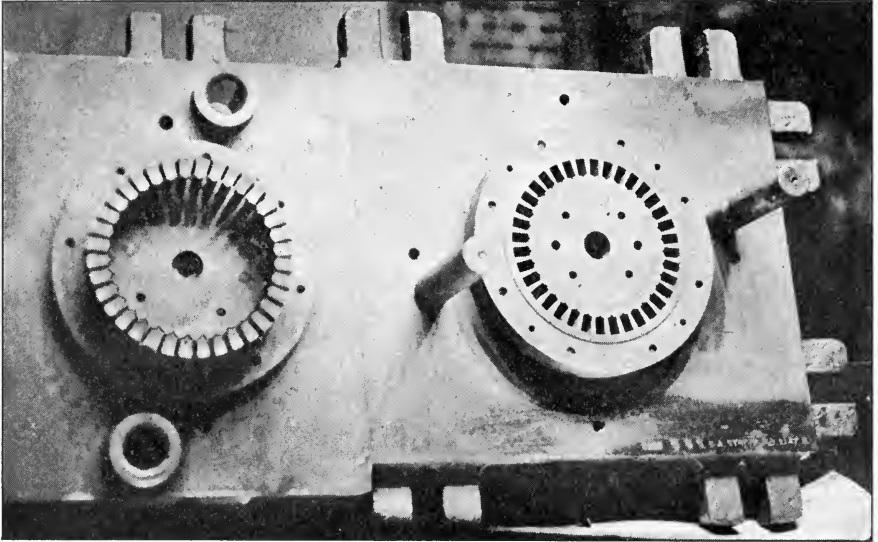

FIG. 81. Good example of intricate tools readily hardened by the barium process.

electric furnace, and the crucible furnace in which the tool is heated in a white-hot crucible, which in turn is heated preferably by gas or oil, entirely prevent oxidation during the heating process if proper precautions are taken. So also do the lead bath and the pack-hardening method. But none of these methods takes cognizance of the fact that even though a tool may come out of the furnace absolutely undamaged by oxidation, the moment it is removed and comes into contact with the air it is immediately attacked and oxidation takes place to a greater or less extent according as the exposure prior to cooling to the normal temperature is long or short. To overcome the difficulty entirely it would appear necessary to quench tools of the kind indicated without defect for the treatment of their Blue Chip steel. It is stated by the makers of a few high-speed steels that their steels will not harden properly by this process. This is anomalous, if true. However that may be, the process, developed only yesterday, as it were, and as yet doubtless capable of great improvement, has been already adopted or is now being adopted by all the leading makers of fine high speed steel tools.

bringing them into the air at all. This it has been impossible to do with the appliances in general use, until the discovery and practical development of the barium chloride process.

**Advantages of the Barium Bath.**—There are, of course, other reasons for the use of a bath in hardening fine tools. One of the most important is the need for absolute control of the temperature to within a very few degrees, and absolute uniformity in heating through every projection and into every recess, in the case of intricate tools, especially when small. While ordinary furnaces, such as have been recommended, are in general very reliable, and their temperatures under sufficiently close control for most purposes, there are nevertheless some fluctuations occasioned by variations in pressure of the gas supply or of the air pressure, and in the size of the door and other openings during the heating. These fluctuations are insufficient in the case of large tools, generally speaking, to be harmful, because of the comparatively long time required to bring such tools to the required heat, even when introduced into the heating chamber after being preheated. The small tool, because of its little mass and consequently the short time required for heating, is liable to be brought to a temperature sufficiently different from the one intended, to affect its quality to a considerable extent. Furthermore, in spite of frequent turnings and other precautions, some parts of tools complicated in shape will heat faster than others by their closer proximity to the incandescent walls of the heating chamber, or because of the direction of the currents which circulate within it. This is of course of less consequence in large tools than in small or fine ones with delicate projections or keen edges.

**Difficulties in Use of Lead Bath.**—Another difficulty, the remedy for which, in the case of certain classes of tools, has been already pointed out, is that of warping while being hardened. Slender tools (like drills, reamers, and those of similar shape) of a size sufficiently large to admit of being thus heated, are not subject to this difficulty when treated in a cylindrical furnace. But small tools of necessity require a different method. The distortion is entirely avoided when the heating is done in a suitable bath. Lead, because of its high specific gravity, is not so well adapted for this purpose as certain others. The tendency is for tools to float to the surface, and thus be irregularly heated, unless held down by some means. The lead bath, while it has been successfully used for hardening high-speed tools, is held at the extremely high temperature required, with some difficulty. It begins to vaporize at about 640 degrees C. (1190 F.), and when heated much above that point rapidly volatilizes, giving off offensive and irritatingly poisonous fumes. These can, however, be conducted away so as to do little harm, if provision be made, as already shown, for effectively exhausting from a properly designed hood.

There are other disadvantages in using the lead bath at these high temperatures, and indeed some disadvantages at any temperature. At a white heat the lead oxidizes rapidly, and even when the surface of the bath is protected by a thick covering of powdered charcoal, more or less of this takes place, the scum rising and floating upon the surface of the lead. A much more troublesome thing is the sticking of the lead to the surface of tools, and the consequent uneven hardness that results from the parts so covered cooling at a rate slightly different from the parts of the surface to which no lead adheres. Efforts to prevent this trouble only seem to aggravate it or to develop new ones equally objectionable or worse. Likewise, impurities in the lead not infrequently damage the surface of the tool with which it comes into contact, especially at the white heat to which it is subjected in hardening high-speed steel. Holes and interstices sometimes remain filled with lead when the tool is withdrawn for cooling, and the result is worse even than when flakes of lead adhere to the surface.

**Difficulties Overcome by Barium Process.**—All these, and other difficulties are overcome by the barium chloride bath process. The chloride does indeed give off fumes, unless precautions are taken to prevent; and a thin coating of it adheres to the tool when it is withdrawn from the bath. This latter, however, is just what is required in order to prevent oxidation while the tool is exposed to the air; and since the film is evenly distributed, there is no uneven hardening. It is possible also to maintain a more uniform temperature, since the melted barium chloride circulates freely, much more so than the heavier lead, so that the temperature throughout the bath does not vary sufficiently to be taken into account.

Heating in a fluid is little or no quicker than in an open fire or in a good furnace. Evidently, however, if the bath itself is uniformly hot throughout, the heating of the tool must be absolutely even. Projections cannot be melted down nor burnt before the interior has had time to reach the same heat as the outside, since it cannot get hotter than the bath, and that is kept uniform at the temperature required for the kind of tools in hand. The danger of blistering the surface or melting down the corners of a tool put into a white-hot furnace without sufficient preheating is entirely obviated. Even if the bath should for any reason be at a temperature high enough to damage a delicate tool thus suddenly subjected to an intense heat, the barium chloride has a melting temperature so high that a relatively cool object plunged into the fluid immediately causes a coating of it to solidify around the article. The coating of solid barium chloride then protects the enveloped article until its temperature rises sufficiently to melt it off.

Furthermore, even though the actual heating of any given tool proceed little or no more rapidly, it is possible to gain a great deal of time



by the simultaneous heating of a considerable number of tools. A basketful of small or medium sized tools can thus be hardened just as well, just as certainly, and just as quickly as a single one. It might be supposed that tools so heated and quenched, that is in promiscuous contact with one another, might vary more or less in hardness. Such nevertheless is not the case, all coming out absolutely uniform.

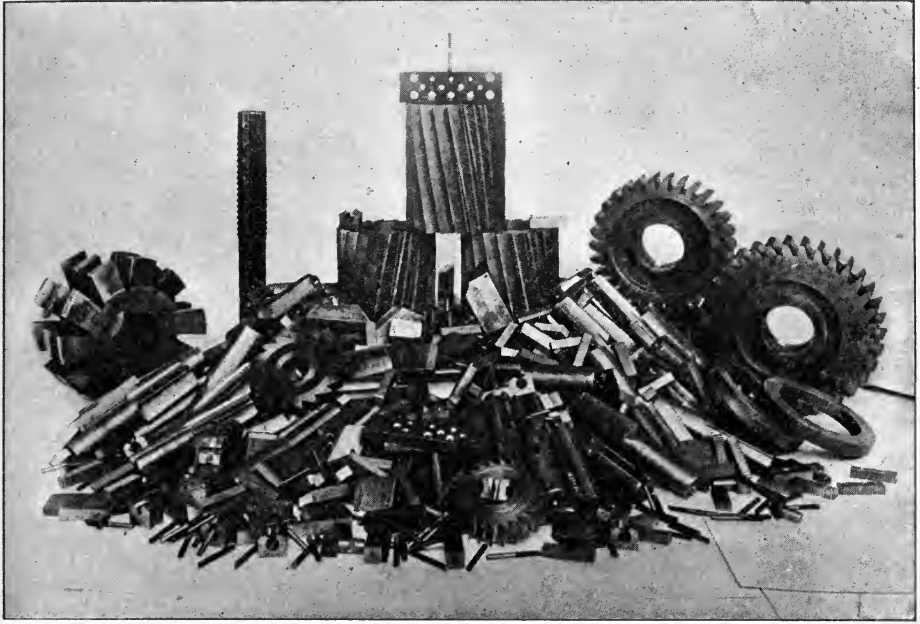

FIG. 82. A day's work. Good illustration of the various classes of tools to the hardening of which the barium process is especially adapted.

**The Furnace and Equipment.**—The furnace for hardening by the barium chloride process may be of any convenient form which will admit the use of a suitable crucible. A vertical gas-fired furnace is preferred, one so designed (Fig. 83) that the flames are directed around rather than toward the crucible, enveloping it in a whirl of heat which is absorbed uniformly over its whole surface. If the flames impinge directly upon the crucible, there is danger of holes being melted into it when the heat is turned on, before the bath has become fluid and able to conduct the heat away rapidly enough.

The crucible is almost necessarily of graphite. It should rest upon fire bricks so disposed upon the floor of the combustion chamber as not only to prevent the bottom falling out, but also to allow the flames to circulate freely about the under portions as well as over the sides. It should be so adjusted as to height that the top rises into the circular opening in the top plate of the furnace. The crevice may be luted up with fire clay or left open, the latter being the preferred method. In this case,

however, the rim of the crucible must rise well into the furnace top, as shown in Fig. 84.

The supply of air and gas, and the pressure, would be the same as for any furnace of similar type but used without the crucible and its

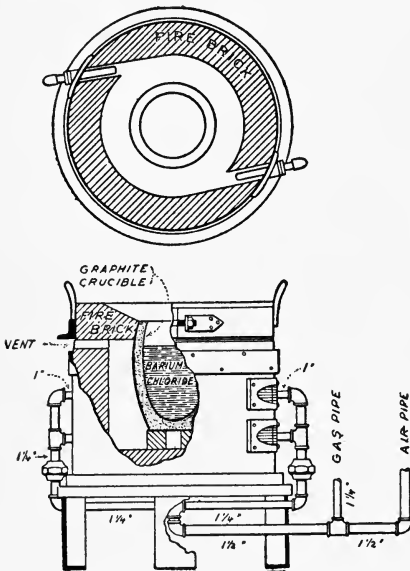

Fig. 83. Cylindrical gas-fired furnace and crucible for use in hardening by the barium chloride process.

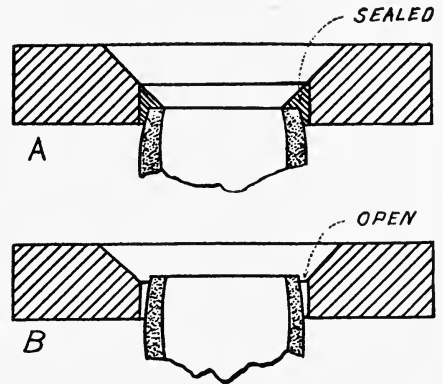

Fig. 84. Fitting of crucible into furnace top. Leaving the joint unsealed, as in B, is the preferable method.

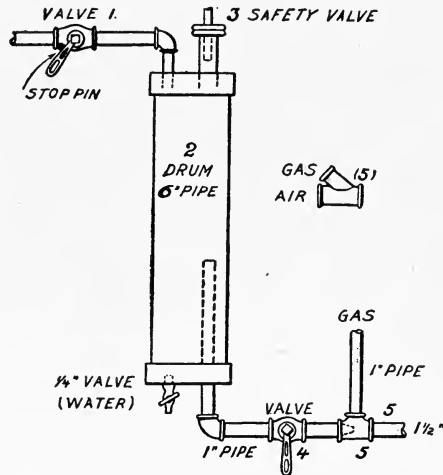

Fig. 85. Reducer apparatus for use where air is delivered at a pressure higher than  $1\frac{1}{2}$  or 2 pounds. Necessary when using compressed air in gas furnace. Courtesy of E. S. Jackman & Co.

1. Valve with an adjustable stop or gage on it.
2. Drum with petcock for draining off the water which appears when the air expands.
3. Safety pressure valve set for about  $1\frac{1}{2}$  pounds to the square inch.
4. Valve for regulating the supply of air to the furnace.
5. Fitting to prevent possibility of high-pressure air backing up into gas supply pipe.

contained bath. Fig. 85 illustrates a desirable apparatus for reducing and regulating the air pressure. In operation valve 1 is opened to the stop, which should be set so as to admit just enough air to blow off gently safety valve 3 when valve 4 is wide open. The flame is controlled by valve 4, but valve 1 must always be open when the furnace is to be used.

A good pyrometer should by all means be a part of the furnace equipment for hardening by this process, so that accurate determinations may frequently be made of the thermal condition of the bath.

It is well also to have a fire-brick cover pivoted at one side so as to be easily and quickly swung over the top when desired. It is convenient to have a small opening in this cover, which in turn can be closed by placing a fire brick over it. The fire chamber of course should be vented, preferably into a stack. In this case, however, it is desirable so to fix the exhaust that there is a space between the opening from the furnace and the pipe or small hood, at which the flame from the furnace can be seen emerging. By watching this the mixing of gas and air can be regulated to a nicety. A very small flame indicates perfect combustion. When no flame is visible, the air supply should be reduced; and if there is a large flame, too much gas is supplied in proportion to the air. The flame should be just barely visible.

**Electrically Heated Furnaces.**—Electrically heated furnaces are in successful use in some plants, and are stated to be economical when used for continuous runs. In this type of furnace the loss of crucibles is practically nothing, one lasting continuously for six months or more; whereas in a gas-fired furnace it lasts scarcely two weeks. It should be mentioned, however, that in certain hardening plants the electrical furnace is not favorably regarded because of the apparent tendency toward emphasizing the formation of a soft skin at the surface of tools hardened in the barium chloride bath.

In such an electrically heated furnace the electrodes are of very soft

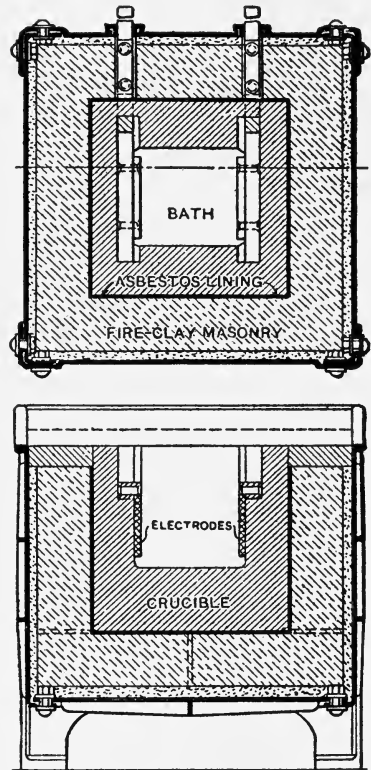

FIG. 86. Electrically heated barium chloride furnace, as used by Ludwig, Loewe & Co., Berlin, who were among the first (if indeed not the very first) to make use of the barium process for hardening high-speed tools.

low-carbon iron, placed opposite each other inside the crucible, which latter is imbedded in a thick layer of asbestos or other non-conductor

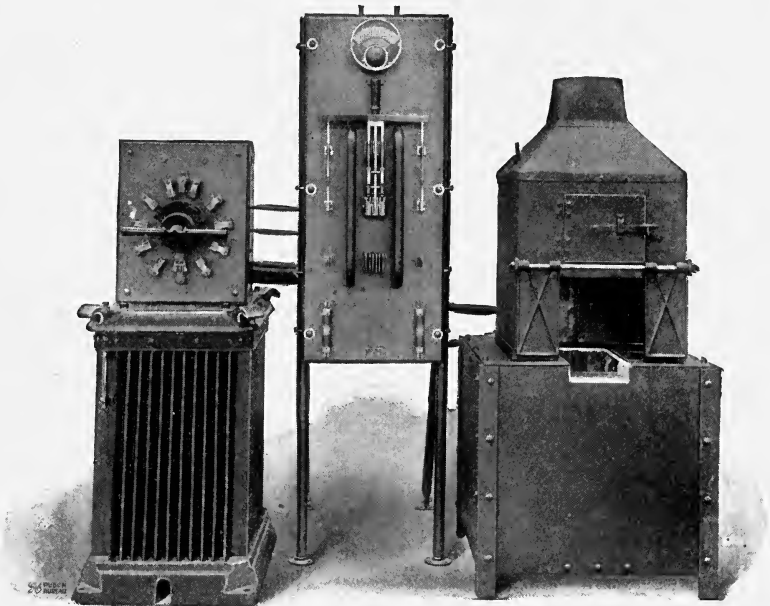

FIG. 87. Electric hardening furnace, switch panel and transformer.  
Courtesy of General Electric Co.

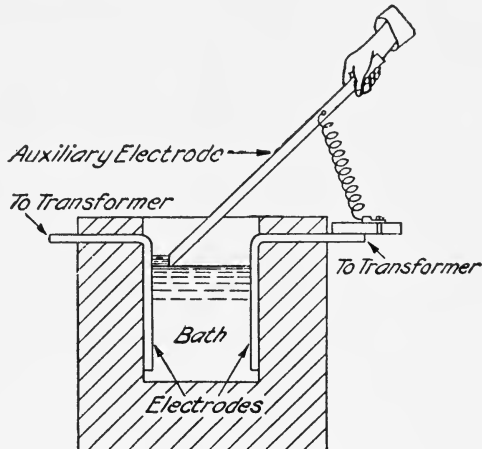

FIG. 88. Method of starting the electrical furnace.

of heat. This layer in turn is surrounded by a thick wall of refractory material like fire clay and other insulating materials, and all are held together by a steel or iron jacket. In this way the heat is so completely

retained within the furnace that at the end of a day's run the exterior is scarcely hot. There are of course the usual accessories, and a controller for varying the voltage and resistance and thereby the temperature. A very low voltage, say from 5 to 60 or 70 volts, is employed in operating the furnace, the higher tensions being necessary only at first while the salts are being melted. Thereafter the voltage does not usually exceed 25. Alternating current only can be used, the direct current setting up electrolysis whereby chlorine is liberated and attacks the tools immersed in the bath. The fumes of course also are increased.

The fusion of the salts mixture is accomplished by moving a supplemental electrode of carbon close to the appropriate iron electrode (Fig. 88) until the sparking has melted some of the salts, which latter then conduct the current. The resistance offered to the current heats and melts the adjacent crystals until the movable electrode has established a melted stream to the other iron electrode. After this the contents of the crucible fuse quite readily. During the melting of course a higher tension is required than afterward. With the controller the temperature can be regulated to within something like 10 degrees C. In taking the temperature, and in hardening also, it is to be remembered that a relatively thin layer, half an inch or so, at the top of the bath is a little cooler than the rest, the difference varying some, but usually being near 10 to 20 degrees C.

**Methods of Operation.**—When starting or renewing the bath, the crucible is filled with commercial barium chloride<sup>1</sup> mixed with a small proportion, say about two per cent, of sodium carbonate, commonly called soda ash. The two substances must be melted together, otherwise, especially if the crystals are used, dangerous explosions are likely to occur. The soda ash, in a way which does not seem to have as yet been investigated, prevents to a considerable extent the rising of chlorine fumes from the bath. These are offensive and very irritating when breathed, and also discolor the surfaces of tools with which they come into contact. The soda ash seems also to have some other effects as yet not well understood. It gradually becomes exhausted, and requires renewal from time to time. It must be remembered that in renewing it is dangerous to throw the ash into the melted barium chloride. The danger is minimized or averted if the ash is mixed with several times its

<sup>1</sup> Barium is one of the small group of alkaline earth metals which includes also calcium (lime) and strontium. Magnesium likewise is sometimes included in the group. Barium never occurs free in Nature, its most common occurrence being in the natural compounds heavy spar and witherite, both of which have commercial uses. The metal itself has no present use in the arts, though intrinsically it is very interesting. It is moderately hard, of a yellowish color, fusible at about 240 degrees C., and burns in the air with great brilliancy. Commercial chloride of barium sells in quantity at about three cents per pound. It fuses at 890 degrees C. (1635 F.). The chemically pure does not melt so readily as the commercial.

own bulk of the chloride before being added to the bath. Care must be taken that the proportion does not exceed that mentioned, otherwise the temperature of the bath is not so easily regulated. The boiling point of the bath seems to be lowered approximately in proportion to the excess of soda ash; and since it is very difficult, if indeed it is at all possible, to raise the temperature above the boiling point, the tools cannot be heated high enough to be properly hardened. The bath should be renewed whenever it becomes sluggish.

The melting should be slow at first. Once well started, however, the bath is rapidly brought to the required temperature, which varies more or less according to the class of tools to be hardened, as already shown. In general, the temperature will be somewhere near, and usually rather below, 1200 degrees C. (2200 F.), being raised above that point or lowered beyond it as required. The exceedingly high temperatures to which roughing tools are raised are unnecessary for the kind of tools to which the barium process is best adapted. Those high temperatures are sufficient to melt down cutting edges and affect the surface finish of tools, and one of the reasons for using the barium process is to avoid precisely this thing, or the possibility of it.

**Length of Immersion.**—The bath being at the proper temperature, small tools may be immersed and left until they are throughout the same temperature as the bath. The time required will necessarily vary according to the size and form of the tools, but in the case of small and regularly shaped tools it will range from a few seconds to a minute, or possibly two minutes. Larger tools of course require a longer time to become heated through; while those of a half inch section, or smaller, should be ready in less than a minute. The operator must learn to gage the time by actual experience. This is comparatively easy with the barium process, for, since the temperature of the bath is no higher than that to which the tool is to be raised, the latter is not damaged by remaining in the bath for some time longer than would be required merely to heat it through uniformly. It is well, nevertheless, not to leave tools in the bath for any considerable time longer than actually necessary.

**The Protecting Film—Quenching.**—When withdrawn from the melted barium chloride, the tool is covered by a thin film, which serves to prevent the surface coming into contact with the air. It is this feature perhaps more than any other one that gives to the barium chloride process its distinctive value. The tool can be quenched in oil without having at any time, from the moment the heating began, been exposed to oxidation. The coating of barium chloride protects the tool to a considerable extent also when the cooling takes place in an air blast, though it flakes off more or less and leaves spots exposed to the action of the air. The better way is to quench in oil. Dies for drop hammers, and tools for other uses where they are subjected to concussions or severe

jarring, are not quenched, as a general thing, but on removal from the barium chloride bath are allowed to cool slowly in the air. The film of barium chloride protects them from oxidation.

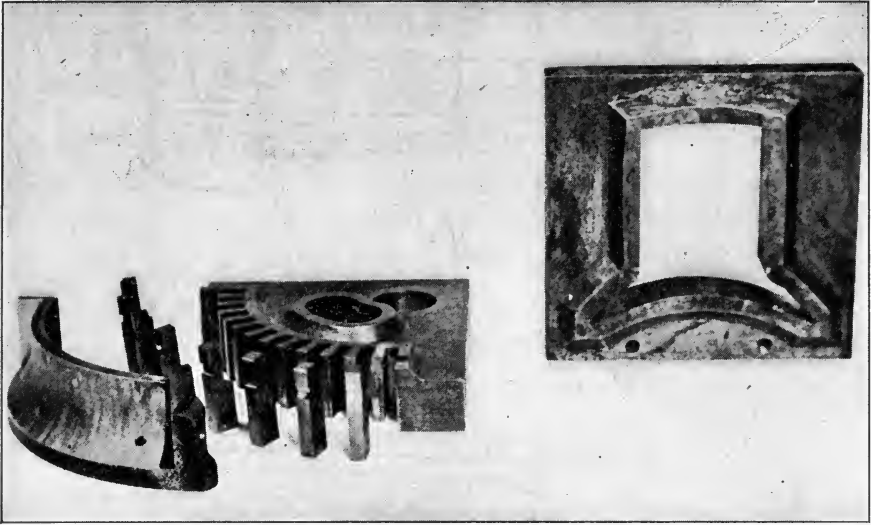

FIG. 89. A tool withdrawn from the bath is covered by a thin film of barium chloride, which protects it from oxidation when exposed to the air.

**Preheating Large Tools.**—All tools of any considerable size should be preheated before being placed in the bath, and in certain cases it is desirable that small ones also receive this treatment. Of course, where very great attention must be given to the absolute preservation of lines and surfaces, large tools also are plunged into the bath without the preheating. Where this is not absolutely necessary, some time is saved by the preheating, for the immersion of a large unwarmed tool of course chills the bath so that it is then necessary to restore the temperature to the required point.

**Avoidance of Temperature Fluctuation.**—This happens also to a much less extent when a tool which has been preheated, is plunged into the bath, since the temperature of the tool is necessarily considerably below that of the bath. Evidently, then, it is desirable that the bath be ample enough to minimize fluctuations due to this cause. Small tools of course do not have any important influence in changing the temperature, and so far as this point is concerned may be put into it without preheating. It is very important that the temperature be carefully watched, and regulated as may be necessary. The experienced operator of course learns to judge very closely by its appearance and behavior whether or not all is right, but even he needs to check up his judgment against a reliable pyrometer from time to time. The influence of a passing shower even, changing the brightness of daylight as it does, is sufficient to make

error easily possible in judging the temperature by the eye. The operator with limited experience must of course be very largely guided by the indicator or record, as the case may be.

**Method of Preheating—Saving Time.**—Heating tools in this way, preparatory to their being placed in the barium bath, effects a considerable saving in time when many are to be treated. Several are kept in the preheating furnace or bath and are given the higher heat treatment in turn.

For preheating, any convenient furnace may be used, though the reliability and convenience of the gas oven furnace especially recommends it for this purpose. The lead bath also is very convenient. The heat is carried up to a low red, not above 600 degrees C. (1100 F.), and preferably somewhat below this. At this temperature no oxidation occurs, and it is perfectly safe to raise tools to this point in the gas furnace and then to carry them through the air to the barium bath. Obviously the preheating temperature must be maintained uniformly at the point mentioned, else some of the tools will get hot enough to scale more or less. Of course, when the barium process is used in hardening tools where this is of no consequence, the temperature in the preheating furnace can be as high as desired.

**Quenching Methods.**—It has been mentioned already that the air blast disintegrates the film of barium chloride which adheres to the tool when withdrawn from the bath, and that it is therefore better to quench in oil. For this purpose no special appliances are necessary. The oil bath already described in connection with ordinary hardening methods serves excellently. The net basket into which small tools can be thrown without further attention until they are removed, makes this tank particularly convenient for use with the barium process.

**Unimpaired Surfaces—Cleaning.**—The oil, like the air blast, disintegrates the coating of barium chloride investing a tool when taken from

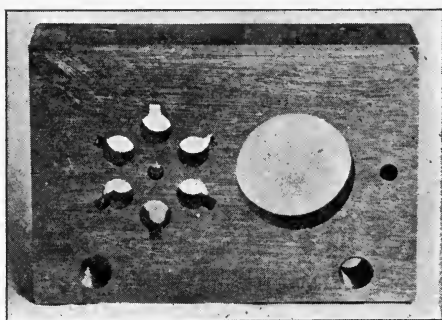

Fig. 90. When the scales of barium chloride have been brushed off and the oil wiped away, the surface of the tool is as clean and bright as before heating. There is no impairment of edges, finish, or color.

the heating bath. When the scales are brushed away and the oil wiped off, the surface is seen to be as smooth and every cutting edge as keen



and perfect as it was before treatment. Not only is the finish unimpaired, but even the color is almost exactly as bright and fresh as when the tool was first machined or ground. Even an expert could not tell merely by looking at it whether a tool had or had not been hardened. It has happened a good many times that purchasers have returned tools treated by this process, before trying them, thinking, from their appearance, that they had not been hardened.

For cleaning off the scales a wire brush is desirable. If any of the barium chloride should stick to the surface or cling to corners and recesses, it can be readily softened by immersing the tool in boiling water for a short time. The scale then comes off without difficulty.

**Closely Sized Tools.**—A number of things are possible<sup>1</sup> with the barium process which were only dreamed of before its development. High speed steel taps and threading dies, and tools used for similar purposes, have until recently left much to be desired. Almost invariably, when hardened by the customary methods, they lose size slightly or have a roughened surface which interferes with their perfect working. Furthermore, the shrinkage is not at all uniform, in some instances varying several thousandths of an inch even in tools of the same diameter, by reason of imperfectly regulated heating conditions and the inherent imperfections of the usual methods when dealing with this class of high-speed tools.

**Difficulties Overcome.**—The barium process entirely overcomes this difficulty. And not only can the size be maintained with almost absolute uniformity, but the tools can be hardened in such a way that they combine the greatest possible cutting powers together with a superior toughness of supporting stock, to prevent breakage under the high stresses to which they are thus subjected. This, with the circumstance that the size is not appreciably altered, that the finish is left perfect, and that the keenness of the cutting edges is unimpaired, especially adapts it to the hardening of many tools (those already mentioned, as well as many other kinds) to the making of which high-speed steel has not heretofore seemed well suited. Taps, threading dies, and other tools with overhanging teeth or cutting edges which, when properly hardened, are likely to break off or crumble, or when let down sufficiently to overcome this difficulty are too soft to last long, can have these teeth or cutters hardened to any desired extent while the body of the tool remains in the annealed condition.

<sup>1</sup> It may be of interest to mention, in this connection, that the barium chloride bath is also excellent for hardening carbon steel tools. When so used, potassium chloride may be mixed with the barium chloride to form the bath, in the proportion of about two to three. The potassium chloride lowers the boiling point of the bath to near the temperature required for hardening ordinary steels, and thus reduces the danger of over-heating them.

**Method for Special Tools.**—The method is exceedingly simple. All that is necessary is to plunge that part of a tool which is to be hardened, into the bath, preferably after the customary preheating, just long enough for the teeth or cutting edges to become thoroughly heated throughout to the required temperature, and then to withdraw it before the stock or body has had time to become heated enough to harden when cooled. The tool is then quenched in the usual manner.

**Cautions.**—It is to be remembered that heating the exterior of a tool only, and then suddenly cooling it, as is required by this method, often sets up strains and causes flaws because the outside and inside portions have not, in cooling, had time to adjust themselves properly. A little care on this point will minimize the difficulty; and the subsequent "tempering" to which most tools of these classes are subjected, can be made to relieve any strains which may have been set up in the hardening.

**Hardening Dies, etc.**—Dies, and other tools subjected to repeated blows or heavy pressures, can be hardened in a somewhat similar way, thus avoiding a trouble which it was not possible, before the development of the barium process, to circumvent — that of dies breaking or splitting open. A die may have its face hardened, as the cutters described above have their teeth hardened, by this part alone being placed in the bath, leaving about half of the body not brought to the high heat. This method is of course especially useful in the case of dies with relatively heavy bodies. Care must be taken, in this case, to move the die more or less, according to size, in such a way as to avoid a distinct line of demarkation between the hardened and the unhardened portions.

**Methods of Handling the Tools.**—Not the least important thing in hardening by the barium chloride process is the handling of the tools. Tongs with spiked or serrated jaws have been mentioned as essential to the handling of high-speed tools during hardening. These are useful in handling some kinds of tools in connection with the present process. For the most part, however, it is desirable to suspend tools of any considerable size in the bath by wires, or in baskets. Grids or perforated metal plates have been used, though these are not so convenient nor so certain. When the wires are used it is of course necessary to take precautions to prevent tools slipping off. Once a tool drops to the bottom of the bath the operator will have his troubles recovering it. Tools with holes through them of course are easily handled by wire hooks.

The baskets may be made of wire netting or of perforated sheet metal. Most operators prefer the wire. A rather surprising thing is that neither the suspension wires nor the much smaller wire (or the thin sheet metal) of which the immersion baskets are made, melt or burn away in the intense heat of the bath. The barium chloride seems to preserve the metal, for there is very little deterioration in the baskets.

When a number of tools are thus heated in a basket, the latter is transferred with its contents, just as if a single tool were being handled, to the oil bath and quenched at one plunge. As previously stated, the contact of the tools with one another does not at all interfere, as might be supposed, with their absolutely uniform hardening.

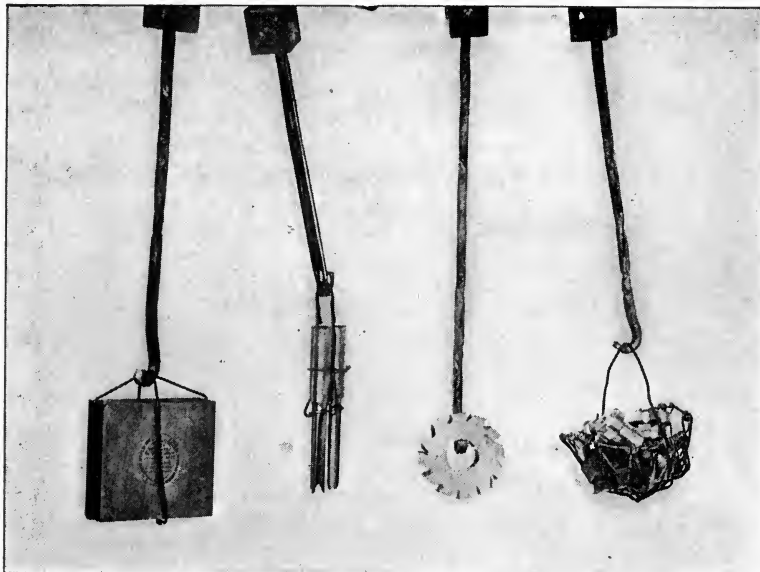
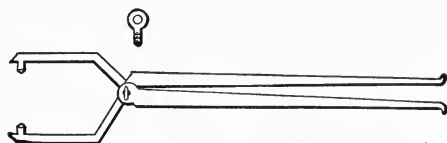

FIG. 91. Methods of suspending tools in barium chloride bath.

**Difficulties.**—As is the case with other methods of hardening, there are some difficulties connected with the operation of the barium process. The chlorine fumes, and the discoloration which tools occasionally



*American Machinist, N.Y.*

FIG. 92. Pair of tongs for handling dies.

sustain from them, have been casually referred to. Such chlorination does no damage except possibly where tools are carelessly left exposed for a considerable time. The exhausting hood and the soda ash in the bath, with proper attention, will take care of this difficulty.

**Formation of "Bubbles" or Blisters.**—A more troublesome difficulty is the formation of "bubbles" or "blisters," and of "pits" on the surface of tools under certain conditions. "Bubbles" seem to form under two well defined conditions, or at any rate appear to be of two distinct kinds. Sometimes a tool which has been preheated, or which was never thoroughly cleaned after annealing, or other heat treatment, is covered with

a thin film, or spotted with flakes, of iron oxide. This apparently melts at a temperature lower than that necessary to hardening, and in melting collects in droplets on the surface of the tool, to which they firmly adhere when cooling takes place. They usually are solid (though occasionally hollow), very hard, but do no particular harm, especially on rough tools, and may be ground off where grinding is permissible or possible — which it is not in case of many tools like taps, forming dies, and the like. The remedy, or rather the prevention, lies in greater care in preheating, the temperature for this operation being kept well below the red at which oxidation begins to take place; and in thoroughly cleaning those tools, even though not preheated, which may be coated with the iron oxide.

“Bubbles” or blisters very like those described, but readily brushed off after cooling, also are of not infrequent occurrence. They are thought to be caused by molten droplets of iron oxide, floating in the bath, coming into contact with the surface of a tool and attaching themselves to it. Since they are so easily removed, and do no harm, no attention need be paid to them.

“Pitting.”—Much more troublesome than either of the “bubbles” mentioned, is the “pitting” which sometimes takes place. There sometimes appears, in this case, to be a melting away of the steel in spots, particularly along the edges or in projections from the body of the tool, leaving usually a slight hollow which sometimes is accompanied by a raised lump as if the metal had melted out and not floated away. More usually a “blister” is raised, beneath which a depression or “pit” is found. When such “pitting” takes place the tool is ruined and is fit only for throwing away or for working down to a smaller size. Investigation into the cause of this peculiar phenomenon has thrown but little light upon it. Inasmuch, however, as it seems rarely to occur,<sup>1</sup> except when the very highest temperatures, those not far below the melting point of high-speed steel, are used, it is suggested that it may be due to the presence in the steel of particles not perfectly homogeneous, which fuse at a temperature below the melting point of the homogeneous portions. No trouble of this sort is likely to be experienced if the temperature of the bath is not allowed to rise above 1200 degrees C. (2200 F.) or thereabouts. This is amply high for hardening nearly all sorts of tools, except those just as well treated by other methods.

<sup>1</sup> Something very similar, if not precisely like this, is of common occurrence when tools are heated by other methods, if extremely high heats are put on.

## CHAPTER IX.

### TEMPERING.

**Extreme Hardness not Essential.**—Some allusion has been made to this peculiarity of high-speed steel, that the fitness of a tool does not necessarily depend upon extreme hardness, but upon the very different property of red-hardness, by virtue of which it resists the tendency to become soft or rub away under stress after having become considerably heated either through the heat generated in working or through being intentionally heated subsequent to the hardening process. As a matter of fact, extreme hardness is not infrequently a detriment to a high-speed tool, since it has, generally speaking, brittleness and internal strains for its concomitants. The latter are set up by reason of the unequal hardening of interior and exterior portions; and the damage they may cause has been repeatedly referred to. Only small and rather regularly formed tools are measurably free from them after hardening.

**“Letting Down.”**—It has been likewise shown that brittleness in tools whose working parts have overhang to such an extent that there is not sufficient backing to prevent crumbling of the cutting edges, is ruinous. A special method in connection with the barium chloride process has been recommended as in large part overcoming this difficulty. Even when this special method is used, however, and always (except as hereafter stated) in the case of tools hardened by other methods, it is desirable, and usually necessary, to “let down” this hardness and relieve the strains by a subsequent treatment, “tempering” or “drawing the temper.” This treatment can be carried to any desired point and practically all strains relieved, and the toughness of the overhanging portions of tools restored to whatever degree required for maximum efficiency. The extent to which the temper should be drawn is determined very largely by the nature and use of the tool, as it also is in carbon steel tools. About the only tools which are not benefited by tempering are those of the heavy lathe and similar types, with well supported blunt noses. These are customarily set at work after hardenings and grinding, without further treatment. The makers of some of the “new” high-speed steels say that tempering is unnecessary for any tools made of those particular steels. Where tools are desired to be of extraordinary hardness this would be true whatever the steel used.

**Tempering not the "Low-Heat" Treatment.**—The tempering here recommended does not correspond precisely to the low-heat treatment of the Taylor-White process, for the temperatures are considerably below the minimum limit of the range recommended by them in that connection. It corresponds almost exactly with the tempering of carbon steels, though the temperatures are, in general, somewhat higher, and perhaps maintained rather longer.

**Results with Crude Appliances.**—As in forging and in hardening, so in tempering, results of a more or less uncertain sort can be obtained with very crude appliances, or perhaps with none at all. A forge fire has served on occasion, though it must be said, that such crude apparatus is not at all conducive to accuracy and uniformity in results. If the novice desires to do a little experimenting with no adequate appliances, this may be done with small risk by taking a piece of, say, tool holder steel, such as is used for light cutting, and heating it until it reaches a dark straw color, and then cooling in the oil bath or the air blast, as when hardening. A greater degree of softness is obtainable by allowing the piece to cool in air; and a still greater by raising the temperature until it reaches a green tinge, and then slowly cooling. Some tools are bettered by following this treatment by another, in which the temperature is raised to a faint red, just perceptible in the dark.

**Exact Temperatures Necessary.**—Important changes take place in high-speed steels within very narrow limits of temperature, not only within the hardening range, but within the tempering range also. And while the colors through which the surface of a piece of steel successively passes, while being heated, are indicative of the temperatures, it must be remembered that colors, especially when so slightly different as are most of those commonly named and used in tempering, are not only difficult to differentiate, even to keen and experienced eyes, but that the judgment concerning them is easily affected by variations in the light. The range of colors, as ordinarily used, extends from light straw to purple, or from 220 to about 275 degrees C. (425 to 530 F.). It is readily seen therefore, that exceeding care must be used in tempering to obtain just the required temperature and no higher. In order to do this suitable appliances are requisite. Trying to temper high-speed steel in a forge fire, as a regular thing, is folly.

**A Simple Method.**—An oven furnace can be used with a moderate degree of success, if it be capable of having its temperature regulated with extreme nicety and provided with a pyrometer for gaging the same. This is little cheaper, if any, than the oil process, though it is available where the amount of work is so small as not to warrant the installation of an oil furnace in addition to the general utility oven furnace.

**Oven Furnace and Sand Pan.**—A better method, recommended by several makers of high-speed steel, and giving fairly accurate results when

the temperature is carefully regulated by frequent observations of the pyrometer, involves the use of a metal sand pan heated by a suitable gas or oil burner (or by other suitable means, for the matter of that), large and deep enough to contain an ample supply of clean and well dried sand. The tools are immersed in the sand and brought to the desired temperature without trouble, if the pyrometer is frequently read. The method is very good also where it is necessary to dispense with the use of the latter instrument, since the temper colors are readily observed.

A satisfactory device, particularly useful where colors rather than the pyrometer are relied upon for determining the proper tempering heats, consists of a metal plate supported in any convenient manner and heated by gas or otherwise, as shown in Fig. 93. The plate is covered by a sheet metal hood or oven.

**Method of Special Alloy Baths.**—A method sometimes used, where the variety of tools is small and it is not desired to provide extensive equipment, consists in heating the tools in baths which melt at predetermined temperatures. Care must of course be taken that the baths are kept as nearly as possible at the melting point. The difficulty of doing this makes the method somewhat uncertain, for a rise of a very few degrees is sufficient to give a different result. Any sort of melting pot sufficiently large for the tools to be tempered, an alloy which melts at the temperature required, and any suitable fire, preferably one that can be easily regulated, as a gas or oil burner, is all that is required. The tools are placed in the melted alloy and kept there from ten to twenty or more minutes, depending upon the size and form, until completely and uniformly heated through. They are then allowed to cool in air, as is customary in all tempering.

If the metal does not chill and set around the tool when it is first placed in the bath, the temperature is too high, and should be at once regulated. It is to be remembered that in order to keep the bath fluid it is necessary that the temperature be maintained slightly above the melting point. This should be considered when preparing the alloy suited to the kind of tools to be tempered, and the mixture so proportioned that its melting point shall be a few degrees below that which it



FIG. 93. A tempering plate with sheet-metal hood or oven, as used in the Crossly Brothers Motor Works.

is intended to maintain. The obvious disadvantage, further than that already indicated, that which very much limits the usefulness of this method, is the impossibility of varying accurately the temperature of the bath without keeping in stock a considerable number of alloys. Where more than one alloy is used it is of course necessary to preserve the identity of each in some way so as to avoid mistakes in the selection for a given use.

**Composition of Alloys.**—It is exceedingly difficult to secure absolute precision in the measurement of high temperatures; and the determination of the rather moderate ones used in tempering even is usually attended with more or less uncertainty. Even when the most perfect instruments are used, the personal equation of the observer enters into their handling and into the observations. The alloys and baths here given melt (or boil, in the case of the linseed oil) at points near enough the temperatures given for all practical purposes. The designation of colors for the several temperatures given is somewhat arbitrary, for color discrimination again is a matter of personal judgment and experience, as well as of light conditions, as has been already pointed out.

TABLE V.

Parts.		Temperature.		Color of Surface of Steel at Temperatures Given.
Lead.	Tin.	Cent.	Fahr.	
14	8	216	420	Very faint yellow.
15	8	221	430	Faint yellow.
16	8	229	440	Light straw.
17	8	232	450	Straw.
18.5	8	238	460	Full straw.
20	8	243	470	Dark straw.
24	8	249	480	Old gold.
28	8	254	490	Brown.
38	8	265	510	Brown, with purple spots.
60	8	277	530	Purple.
96	8	288	550	Deep purple.
200	8	293	560	Blue.
		302	575	Polish blue.
Boiling linseed oil .....		316	600	Dark blue.
Melted lead .....		321	610	Gray blue.
		332	630	Greenish blue.

**Tempering in Oil.**—A well-equipped hardening plant will have a good oil-tempering furnace. This consists essentially of a tank of suitable size and form to contain an ample supply of oil, a furnace arrangement for maintaining the temperature at the requisite point, and a high heat thermometer, or preferably a pyrometer. Inasmuch as it is necessary to regulate the temperature within a very few degrees, the furnace must be of a kind whose heat can be controlled to a nicety. A gas furnace is on that account preferred. There should be a basket of



perforated metal or of wire netting, in which tools may be placed for immersion. This will facilitate their removal, since all are removed with the basket, without any need for fishing them out separately.

**Method of Operation.**—The basket and contained tools may be placed in the oil while the latter is still cold, though it is better first to bring the temperature of the bath up to something like 200 degrees C. Since the main purpose of tempering is to relieve strains, it is well to avoid plunging

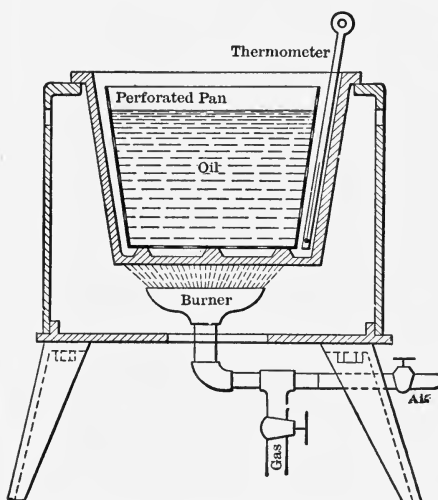

FIG. 94. Good type of furnace for tempering in an oil bath. Oil could be used for fuel as readily as gas.

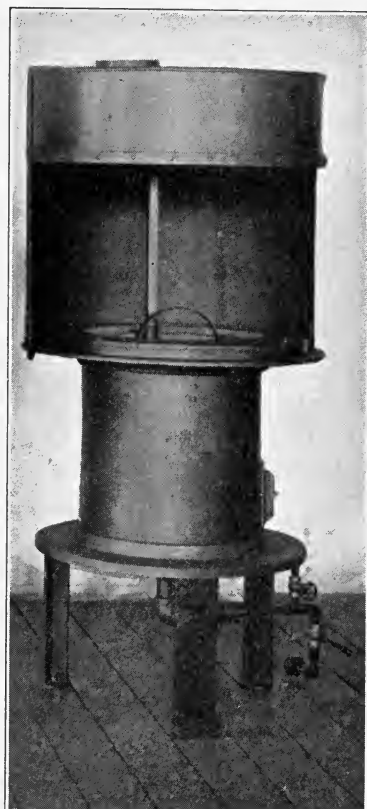

FIG. 95. Cylindrical oil-tempering furnace with hood.

tools into a bath much hotter than this, for to do so would heat the projecting and exterior portions so rapidly as to set up new strains which then have to be overcome. The gradual heating, allowing the heat to penetrate as it rises, softens the exterior portions enough to allow a readjustment of the molecules under stress, while at the same time it leaves the steel less hard and more tough according as the temperature is high or low within the tempering range.

The temperature of the oil bath is raised to the point requisite to the tools in hand, and these are left immersed for some fifteen minutes or more, the time depending somewhat upon their size and shape. Large tools are to remain in the bath longer than is necessary for small ones. The latter are not harmed by remaining in the oil, in case it is desirable to temper large and small tools simultaneously. It is to be remem-

bered however, that only tools requiring the same degree of heat can be tempered at the same time. Large tools may be suspended in the bath in any convenient manner. When removed, the tools are allowed to cool down in air without further attention. Large cutters and dies often are left to cool off in the oil.

**Kind of Oil Required.**—The oil used may be any rather heavy kind, that best suited being the so-called heavy or black cylinder oil produced from petroleum. Tallow is sometimes used. The former can be raised without trouble to as high a temperature as is necessary in tempering.

**Electrical Tempering.**—Drawing the temper by the heating effect of the electric current is possible, though not much practiced commercially. The method is useful if the barium process is not available for hardening, in the case of such tools as milling cutters and others having a central opening and requiring the body to be tough while the cutting edges are left well hardened. A vise and mandrel suited to the work in hand are

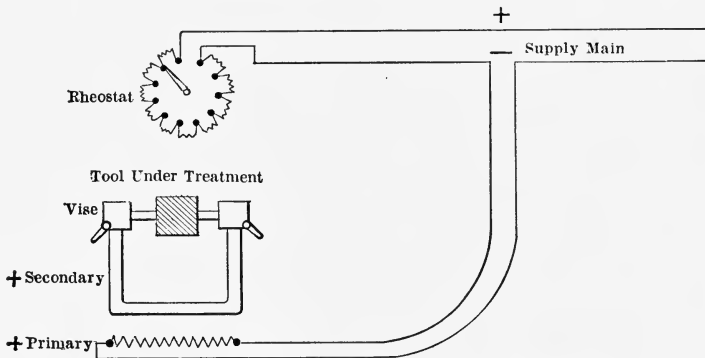

FIG. 96. Apparatus for tempering milling cutters electrically.

connected to a circuit and resistance regulator, as in electrical hardening. The tool having been slipped over the mandrel, and fitting loosely upon it, the current is gradually turned on and the heat brought up to the required point. Evidently the central portion of the cutter is first heated, and also most heated unless the operation be continued for a considerable time; and consequently the outer portions retain their hardness to a much greater extent than the central, which latter are correspondingly toughened. It is possible to duplicate very accurately any previously adopted degree of temper in tools of the same form and size by merely using the same current regulation. Obviously, however, the process is rather limited in its applications because of the difficulty of accurately determining and regulating the temperature of the surfaces of tools of various shapes and sizes. The method is an improvement upon the simple and well-known expedient of heating tools of the kinds mentioned by the insertion of a hot rod, somewhat smaller than the

opening in the tool, and whirling the latter until the desired color appears upon the surface.

**Importance of Proper Tempering.**—Certain makers of high-speed steels state that while tempering, after hardening, is desirable in the case of their particular steels, it is not essential. The statement is not sufficiently accurate. Tempering is not essential in the case of any high speed steel tools of certain classes, or of any class if only moderately effective work be acceptable. The proper tempering of carbon steel tools is even more particular than the hardening; and if this is not exactly true in the case of high speed steel tools,<sup>1</sup> tempering them to suit the requirements of the particular service for which they are designed still is highly important. The failure to get desirable results from the use of high-speed tools can almost invariably be traced to improper hardening or, more likely, improper tempering. It is exceedingly important therefore to have at hand suitable data, in order that the proper temper, as well as the proper hardening heat, may be given every tool. Such data have not heretofore been generally available, each user of high-speed tools having to depend almost entirely upon his own experience and observation. This is after all what must be depended upon in any toolmaking plant; and it is perfectly obvious that some system of recording accurately the treatment of particular tools is absolutely necessary in order to arrive at determinations in the many special cases that arise wherever many tools of various sorts are used. This matter will be further considered in a subsequent chapter.

**Tempering Temperatures.**—The following data as to tempering tools are accurate for practically all good makes of high-speed steel, and cover in a general way the range of these tools.

The temper of high-speed tools is, in general, drawn (when they are tempered at all) somewhat farther than is done with carbon steel tools, as may be seen below.

Lathe roughing tools, and indeed all tools for heavy roughing, are left untempered.

Large reamers, and drills with heavy stocks, 230 degrees C. (440 F.), equivalent to a light straw surface color.

Ordinary drills, small reamers, and other tools of the sort necessarily having rather light stocks or bodies and subject to considerable torsional strains, 240 degrees C. (460 F.), a full straw color.

Threading dies and taps, 260 degrees C. (490 F.), very dark straw or brown-yellow.

Ordinary milling cutters, and the like, 210 degrees C. (400 F.), faint yellow.

<sup>1</sup> Allusion has been already made to the claims advanced by the makers of some of the so-called "new" high-speed steels, that these require no letting down or tempering.

Punches, stamping or cutting dies, and shear blades, 280 degrees C. (530 F.), purple.

Chisels, snaps, and the like tools subjected to sudden shocks, 300 degrees C. (570 F.), polish blue.

Woodworking tools of nearly all sorts, 275 to 300 degrees C. (525 to 625 F.), light purple to greenish blue, according to shape and kind of wood to be cut.

Brass working tools, 20 to 30 degrees C. lower than for iron or steel cutting tools of same kind.

## CHAPTER X.

### ANNEALING.

**Advantage in Using Annealed Stock.**—It is now customary for makers to furnish high speed steel stock annealed, instead of as it comes from the hammers or rolls, as formerly, though in most cases the unannealed can be had if specially ordered. This is very greatly to the advantage of the user, since the bar stock thus becomes available in a variety of ways without preparatory treatment, it being, for example, a comparatively easy matter to machine tools from stock, should this be desirable, as well as to forge them. The use of annealed steel lessens the need for unusual care in the matter of bringing tools out of the hardening treatment with shanks or necks soft enough to minimize the danger of breakage at those points. It is to be noted also that the long annealing at the mills gives to the steel a uniformity and freedom from strains which otherwise would considerably limit the utility of tools made from it. Most high-speed steels, can, by proper annealing, be made nearly or quite as soft as ordinary tool steels. The method by which this is accomplished at the mills has been briefly described in a former chapter.

**Annealing Furnaces.**—Whether because only the unannealed stock is at hand, or because during the forging or other processes through

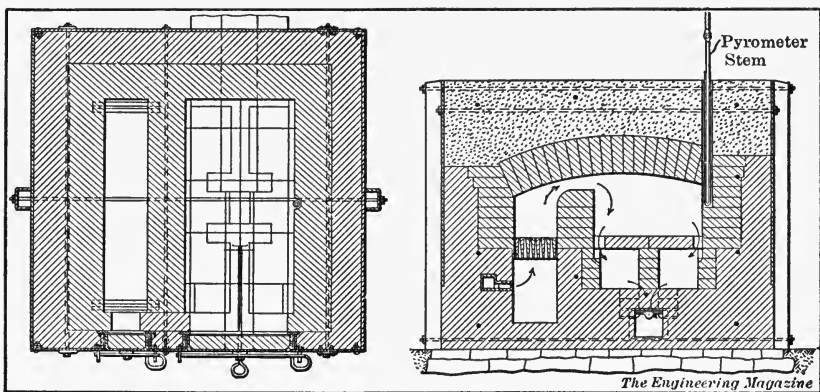

FIG. 97. Annealing furnace at works of the Brown & Sharpe Manufacturing Co.

which it may have passed during the making and prior to the final hardening, a tool may have become more or less hard, very likely unevenly, it not infrequently becomes desirable or necessary to anneal

pieces in the toolmaking plant. If much of this is to be done a suitable annealing furnace of the necessary capacity of course is requisite. A gas fired oven furnace of ample size is most often used, though the slightly less convenient coke or anthracite fired furnace also is in all respects suitable and satisfactory. An important requirement in design is the ability to sustain a continuous high heat for a long time, if necessary. For ordinary annealing such as may be expected to be done in an ordinary toolmaking plant, even this is not essential, for the heats need not be of a duration comparable to that given at the mills. For occasional work the ordinary furnaces used in hardening are sufficient.

**Uniformity Essential.**—A prime essential in annealing is uniformity in the result — a given piece must be annealed to the same extent throughout. Obviously, therefore, the heating must be uniform, and it is necessary that the furnace be such that the heat shall be evenly distributed throughout the fire or heating chamber. The coke furnace is especially good in this respect, though gas furnaces are now designed with muffle or baffle plates, or double floors, so as to accomplish the same result.

**Methods of Rapid Annealing.**—Quick annealing, especially with but indifferent facilities at hand, is not to be encouraged; for though fairly good results may sometimes be thus obtained, it must be remembered that proper annealing is a process requiring much care and good judgment. If necessary to anneal a piece without any of the desirable appliances, this may be done with more or less success by heating slowly in an open fire or furnace to a blood red, holding there for some little time, and then allowing the heat to die down very gradually, the tool remaining in the fire or furnace until entirely cold. The slower the temperature is raised and then lowered, the better the annealing. This holds true with all methods in general use. If a smith's fire be used, care must be taken to make it deep and to cover it up well after the desired heat is reached, so it will die down very slowly. It is better to build a hood over the fire, resembling that mentioned in an earlier chapter, and to fill this up with coke before the fire is allowed to go down. If a gas or coke furnace be used, air must be carefully excluded during the cooling, to prevent excessive oxidation. The heating will occupy anywhere from two hours to ten, according to the size and condition of the piece, and the degree of softness required. The heat must thoroughly and uniformly penetrate the entire piece.

Instead of cooling down in the fire or furnace, the tool being annealed may be withdrawn and buried in sand, ash, lime, or asbestos of generous quantity and previously well heated up, and allowed to cool there. A quicker method is sometimes employed, which, however, is not very certain, and but partially accomplishes the object. The steel is heated to a dull black red and plunged into hot water. The temperature of the

piece must not exceed that indicated, while that of the water must be little short of the boiling point.

**Protection from Oxidation.**—If possible the steel should be enclosed in a muffle, even if nothing better be at hand than a piece of gas pipe, and packed closely in green coal dust, coke dust, powdered charcoal, or the like substance, to generate a non-oxidizing gas which shall envelop the pieces under treatment. Asbestos, ashes, or sand also serve pretty well, though usually the surfaces of the annealed tools are less perfect. It is much better to have a suitably designed muffle, preferably of cast iron and lined with fire brick, for this use. A rectangular box provided with a flanged lid (Fig. 98) is excellent for the purpose. The flange should fit very loosely into a grooved rim projecting from the top of the box. The groove is filled with sand, fine ash, or fire clay, to exclude air. The clay answers this purpose rather better than the sand. It is well to have one or more small holes through the cover for the escape of gases; otherwise the clay filling may be blown off in places. It is very necessary to take precautions for the exclusion of hot air (and cold also, for the matter of that), because surface oxidation of the steel takes place, in that case, frequently to such an extent as to impair the uniformity of the subsequent hardening.

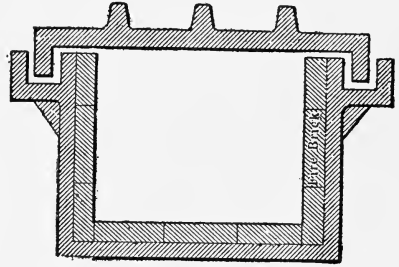

FIG. 98. Pot for annealing.

**Time and Temperature Required.**—The box and contents are then placed in the moderately hot furnace and slowly brought to something more than a dark red, anywhere above the point at which softening is completed, and below that at which recalescence begins, or above 700 degrees C. (1300 F.) and up to near 800 degrees C. (1460 F.), somewhat beyond which lies the critical point in heating.<sup>1</sup> This temperature is maintained from one to four hours, according to the size of the box and of the pieces being treated. The point is to be sure that every piece is completely and uniformly heated through. Soaking, that is to say, long continued heating, is likely to be injurious, and should be avoided. It tends to make the structure of the steel coarse, as it does in the case of ordinary steel, increasing at the same time the liability to cracking during the subsequent hardening.

It is of course possible to arrive, by experimentation, at a definite time for which given bars or pieces must be heated in order to anneal perfectly and without damage to the structure; but in miscellaneous work the conditions vary so much that no specific rule can be laid down.

<sup>1</sup> See the chapter on Nature and Properties.

Only experience can be relied upon as a guide, though the limits above mentioned will indicate the approximate range of time within which the heating is to be done. It is better, at first, to under-heat rather than over-heat (that is, continue the treatment for a shorter rather than for a longer time than seems probably necessary), since the annealing can be repeated in case it has not been carried far enough.

**Maximum Temperature.**—More important still is the maximum temperature maintained. If raised considerably above that already indicated (800 degrees C. or 1460 F.), the purpose of the treatment is in part defeated because near this temperature the changes begin to take place which are necessary to hardening; and the steel comes out imperfectly annealed, if indeed not quite hard at times, especially if the cooling proceeds less slowly than it should. The temperature may sometimes, under conditions insuring extremely slow cooling, range a hundred or more centigrade degrees higher. Frequent readings of the pyrometer are very desirable.

**Cooling.**—The heating having proceeded until the steel has been completely and evenly hot throughout, the heat is turned off and the furnace allowed to cool down very gradually — the slower the better — and the contents removed only when quite cool. This requires, under the best conditions, several hours. Twelve hours is a short enough time; and two or three times as long is much better. Cold air must, during this time as well as during the rest of the treatment, be carefully excluded from the furnace.

**Prevention of Discoloration.**—The surface of high-speed steel so annealed comes out very well, but usually somewhat discolored. It is sometimes desirable to leave the brightness of the surface unimpaired. This is accomplished to a moderate extent by placing in the bottom of the annealing box a handful of resin and a second handful sifted over the top of its contents. A thin black film covers the pieces when taken out. This objection is avoided by keeping the contents of the annealing box constantly surrounded by an envelope of gas, air being absolutely excluded during the whole time. To do this there must be a continuous supply of gas passing into the box, which latter is provided at one end with a small iron pipe screwed into a suitably threaded hole at one end and long enough to extend well outside the furnace. At the end of the annealing box opposite the pipe is a small orifice. The box having been filled and closed in the regular way, the pipe is connected with a gas supply. The jet issuing from the small orifice, after the air has been driven out and the box filled with gas, is lighted and the box placed in the furnace to be heated in the customary manner. The gas, very little of which is consumed, takes the place of air in the interstices around the steel to be annealed, before the heating begins, and completely fills them during the entire treatment, so that there is no possibility of even



enough oxidation to color the surface of the pieces. The method is excellent where it is necessary to anneal finished tools.

**Electrical Annealing.**—Experiments have been carried on looking to electrical annealing and to bright annealing by immersion in a bath of fusible metallic salts, somewhat after the manner of the barium chloride process for hardening. Moderately successful results have in some cases been obtained; but the methods are not as yet sufficiently developed for commercial use. The two methods have also been combined, with apparently good results, the salts bath being heated by the passage through it of an electric current.

## CHAPTER XI.

### GRINDING.

**Importance of Proper Grinding.**—Hardening has been very generally emphasized as the one most important operation in the manufacture of high speed steel tools — the steel of suitable quality of course being granted. In one sense this doubtless is true, for a well-hardened tool will do moderately good work even when the remaining operations are badly done, or, in the case of some of them, quite omitted. It is equally true, nevertheless, that a tool giving maximum service must have passed successfully through all the operations necessary to its manufacture. These operations, from the bar stock to the finished tool, may be given as forging or otherwise forming, hardening, tempering, and grinding. Certain of these of course are simultaneous in some cases, as when a milling cutter is sharpened before hardening, at the same time it is formed. Of these operations, grinding is fully as important as any other, the same care and precision being required for the development of the highest possibilities in a given tool. As elsewhere in the manufacture of high-speed tools, incompetent or careless workmen, or inefficient methods, may easily spoil or render defective an expensive tool. It seems very certain that a large proportion of such tools, as made and used in ordinary practice, are more or less injured by improper grinding. The operation is in many places regarded indifferently, and in consequence there is a serious loss in efficiency. Undoubtedly a good many discouraging trials of the new steel turn out badly more on account of improper grinding than for any other reason. Of course not every tool plant can be equipped with the most approved machinery, and use the very best methods in grinding, any more than in the hardening and tempering of these tools. But it is to be emphasized that the best results can be expected only when efficiency characterizes every detail in their manufacture as well as their use.

**Kind of Stone to Use.**—Much has been said as to the kind of stone best suited to the grinding of high speed steel tools. A good many makers of the steels recommend emery, or other composition stones; others prefer sandstone, and still others indicate that either may be used under suitable conditions. The fact of the matter seems to be that any of these several kinds of grinders can be used with satisfactory results — if the stone used be selected with reference to the work to be

done and the proper conditions be maintained. It does not follow that all are equally efficient. The thing to be desired in this respect is that the wheel shall grind as rapidly as possible, leave a sufficiently smooth finish, and yet not overheat the tool. A coarse and hard wheel ordinarily will grind faster than a fine and excessively soft one, say like a sandstone. In the case of artificially bonded wheels other than sandstone, a coarse, soft stone will cut faster than a fine hard one, the softness allowing the grain to break down readily, and thus continually to present new cutting grains to the surface being abraded, and the coarseness allowing large, sharp points to engage the work. For this reason, and also because it can be speeded up much faster, an emery wheel can be made to grind high-speed steel more rapidly than a sandstone. The ease with which artificial stones can be modified in grit and bond to meet the various requirements, gives them another advantage. While it is probably true that most of the damage suffered during grinding high-speed tools occurs when emery wheels are used, it by no means follows that the fault necessarily lies in the use of a wheel of this kind. As a matter of fact, such troubles usually result from the unintelligent

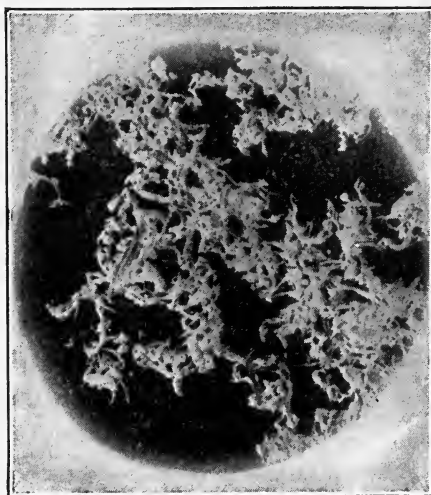

FIG. 99. Chips from normal grinding magnified.  
Courtesy of the Norton Company.

use of the wheels. The inexperienced or inattentive operator is likely to forget that the emery wheel is running at a speed very much greater than the sandstone possibly can run, and that in consequence the tool pressed against its face is heated up much more quickly. The result is likely to be a ruined tool.

**“Glazing” and “Loading” of Stones.**—A difficulty frequently met with heretofore in the use of these wheels, in grinding high-speed steel, has been their tendency to “glaze” and “load,” that is, for the cutting

grains at the grinding surface to become worn down smooth and dead even, and the pores or interstices in the bonding material to fill up with the abraded particles of metal. These two conditions sometimes occur separately, and at others together. When they do occur, grinding ceases in proportion as the surface of the wheel is more or less glazed and loaded. To grind, that is, to "cut," the grit at the surface of the wheel must be sharp, not worn down smooth; and the interstices between the grains must not be filled up. A grinder is a sort of cutting tool. The cutters are the infinite number of sharp grains or grit whose angles are exposed at the surface of the wheel. These act individually very much like the corner of a broken file in scratching a metallic surface. They get behind slight inequalities in the surface being ground, or force themselves into the metal, and in either case push off a thread-like filament (Fig. 99) whose size depends upon the size of the grit and the pressure applied. Evidently there can be no grinding under the conditions just stated, that is, where the grit is worn down smooth or the interstices of the grinding surface filled up to such an extent that the grit does not protrude. In hand grinding the tendency is, when one or both these conditions prevail, to press the tool the more firmly against the wheel. Since little or no work can be done with the grinding surface in this state, the additional pressure serves only to increase enormously the friction, and generally to ruin the tool by the sudden heating of its surface or cutting edge.

**Ruin of Tools in Grinding.**—It may seem singular that a high-speed tool should be spoiled by any temperature to which it might be raised in grinding, for that is of course not comparable to the temperatures used in the forging or hardening. The damage comes about in large part through the "drawing" of the "temper," and in part through "checking" or the formation of surface cracks. Softening of high-speed steel, as previously shown, begins at a temperature approximating 550 degrees C. (1100 F.) and is completed near 700 degrees C. or 1300 F. The lower temperatures in this range are easily possible in careless grinding; and indeed, the higher, corresponding to a low red, has been observed at the point of a tool flooded with water. The more frequent injury probably is due to the manner in which the frictional heating occurs — the sudden rise of temperature in the thin outer skin of the tool face applied to the surface of the stone, and consequently its rapid expansion without reference to the unheated portion back of and adjacent to it. The result is that numerous checks or cracks are formed, more or less deep according to the pressure, speed and duration. Under these circumstances, if the stone be used wet the trouble is likely to be greatly aggravated; for the cold water coming into contact with the heated surface is almost certain to cause a multitude of checks over the whole surface affected.

**Wheels Suited to the Work.**—A large part of the trouble, if not the whole of it, lies in the use of wheels not suited to the work in hand. It is well enough understood that the use of one form and size of lathe tool, standardized as much as it may be, for all sorts of jobs and on all kinds of material, is not only uneconomical, but exceedingly foolish. Various jobs require particular tools, such as are specially adapted to the work in hand. Precisely the same thing holds true of grinding wheels. It is quite as absurd to use the same stone for finishing brass and for sharpening tools; and likewise to use for grinding high-speed tools a wheel made for an entirely different class of work. If a stone be used which has been properly selected, and which is run under suitable conditions, there will be no glazing, even if the pressure be excessive. The latter condition will but tear up the wheel and overheat the tool the faster.

**Wheel for General Use.**—It may be said, in general, that the difficulties just described arise from the use of a wheel too fine in grit or too hard (or close-grained) in bond. Wheels made especially for grinding hard carbon steel tools give but moderately good results when used on high-speed tools. The grain is too fine, and the grade slightly too hard. The ordinary run of high-speed tools such as are used in lathe, planer, shaper, boring mill, and the like work, require, for moderately rapid and sufficiently smooth grinding, a wheel of quite coarse grain. Mr. Taylor recommends for general work a mixture of grits, numbers 24 and 30; that is, grit passing through screens with openings respectively 24 and 30 to the inch. For all tools such as described above, unless intended for finishing cuts, a 20-combination is entirely satisfactory, and can well be used for all sorts of rough grinding, and even for a good deal of finish grinding. It is a mistake to suppose that to produce a fine finish in grinding the wheel necessarily must be of a fineness to correspond. This is true of soft metals, but not at all of very hard. The smoothness of the finish in this case, which includes high-speed steel, depends more upon the depth of cut (pressure applied), speed, and softness or openness of the wheel, than upon the fineness<sup>1</sup> of the grain.

**Wheel for Finishing Tools.**—Tools requiring very keen cutting edges, like drills, milling cutters, and in fact all fine tools or such as are used for finishing cuts properly speaking, need a fine-grained wheel, as well as a softer one, to insure the best results—say what corresponds to a 60-grain J-grade alundum wheel. For tools intermediate in finishing

<sup>1</sup> It may be mentioned here that the fineness of grain or grit is designated with approximate uniformity by makers of these wheels, by use of the numbers corresponding to the number of holes per inch in the screen used. For indicating "grade," however, each maker seems to be a law unto himself and to use a different nomenclature—most frequently the letters of the alphabet. Even the very general terms "hard," "medium hard," "medium," "soft," and the like, vary more or less as applied by different makers.

quality or size between the class just mentioned, and large roughing tools, a wheel of grit and hardness (or softness, rather,) between this and that already designated for the roughing tools, is often used. A combination 20 and 30 is much in favor. It is a matter of great consequence that the wheel used be just suited to the tools; and for this reason it is very desirable that a sufficient variety, not only in form, but in grade and grain, be kept on hand, so that each batch of tools can be most economically and perfectly ground. The time required for changing wheels is in no wise comparable to that gained and the economy secured as a result of the changes. This raises the question of the organization of the tool-grinding service, which will be considered in another paragraph. To avoid the necessity of truing a wheel each time a change is made, it is desirable that each be mounted on its own arbor and screwed onto the spindle when required, or attached in some other way to secure perfect centering.

**Running Speed Important.**—The speed of the wheel should be that recommended by the maker. Not “somewhere near” it, but as closely approximating it as possible. This is very important, and the general disregard of it, the inattention to the maintenance of a suitable running speed, in general as rapid as the bond of the wheel will safely permit, is responsible for much of the trouble that arises in grinding. Indeed it may be said with assurance that practically all grinding troubles arise from ignorance of proper conditions, or inattention to them.

**Additional Considerations.**—There are other conditions also involved in the proper grinding of high-speed tools — and of all classes of work likewise, for the matter of that. Evidently, for one thing, the wheel must be true; and for another, it must run steadily. To secure the latter condition, the machine, whether intended for hand or for automatic grinding, needs to be strongly built and even massive, and the spindles and bearings as large as may be consistent with the size of the wheels used. Provision of course must be made for keeping grit out of the bearings. It is a great mistake to suppose that any old worn-out stand will do, even for rough hand grinding.

**Truing Wheels.**—The wheel once properly mounted (between soft metal-faced flanges with a diameter at least a third that of the wheel, or at any rate with suitable washers between wheel and flanges) in a rigid stand or machine, it must be exactly trued by a diamond dresser held firmly in position by the tool post or other holding device. Dressing by hand is unsatisfactory, and dressers other than the diamond do not yield a sufficiently good condition of the grinding surface. In truing, the diamond must be constantly and thoroughly flooded with water, or it is liable to be flattened. But little of the wheel material should be removed — only enough so the sound is absolutely even as the dresser passes back and forth over its face. Very light pressure, therefore, is required.

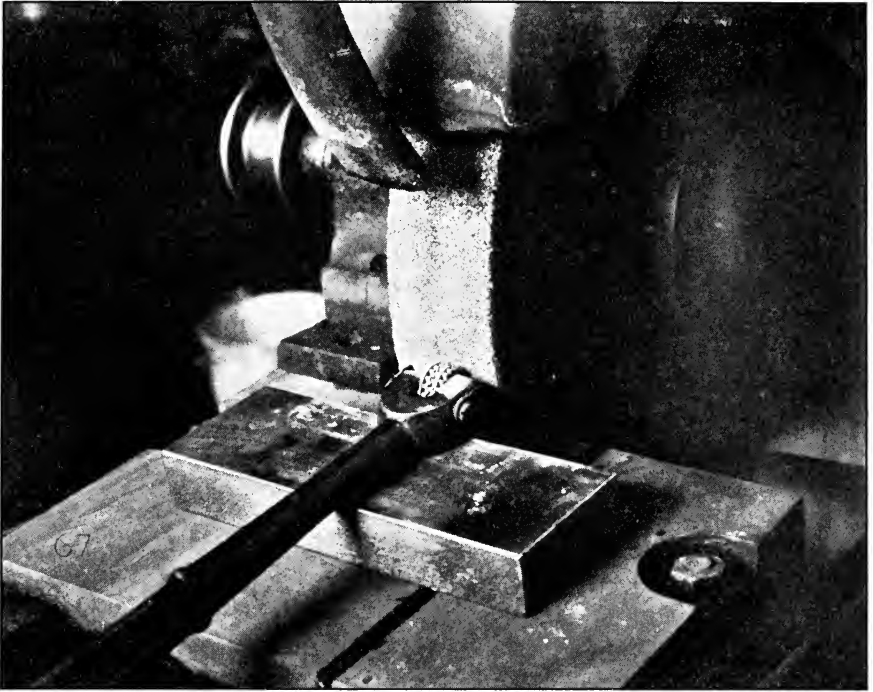

FIG. 100. Dressing an emery wheel. This method is good enough for many kinds of work, but not for accurately grinding high-speed tools.

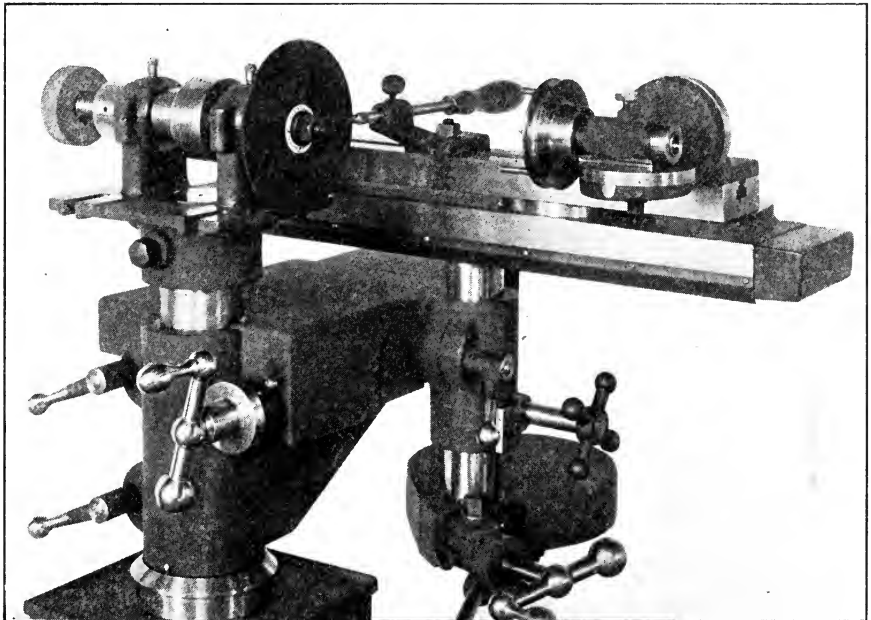

FIG. 101. The dresser should be a diamond tool, held firmly in a post, as shown here.

**Automatic or Semi-Automatic Grinding.**—Such precision as is here indicated of course implies automatic or semi-automatic machine grinding of tools, and is not essential in rough grinding by hand, though certain of the recommendations obviously apply in this case also. Hand grinding evidently has no place in a well-regulated shop manufacturing or using tools in such quantity as to warrant an adequate equipment for putting and keeping them in proper shape. Nothing is more certain than that a large part of the ineffective

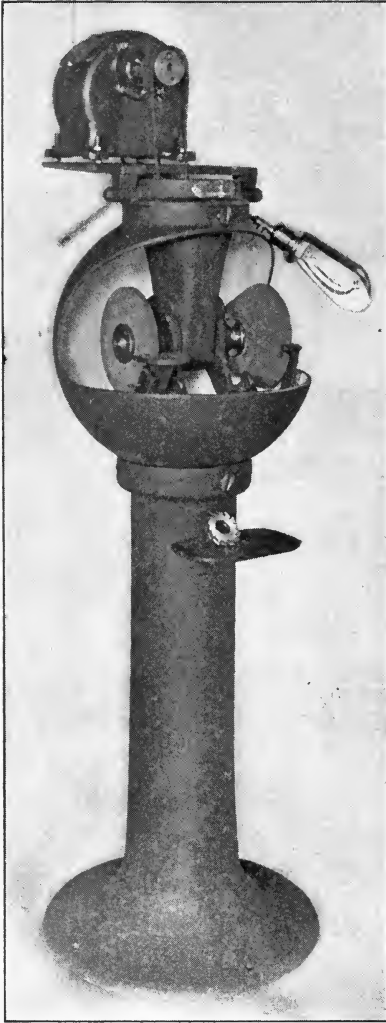

FIG. 102. Walker self-contained floor grinder. This grinder has much to commend it where hand grinding is permissible. The rotating hood forms also a bowl which may be kept filled with water, for the collection of dust. Caliper rests, as here shown, are essential in the hand grinding of high-speed tools.

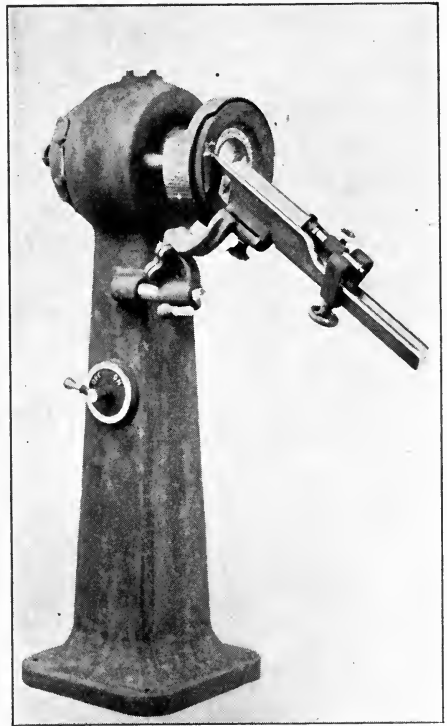

FIG. 103. Yankee drill grinder. Motor-driven and entirely self-contained. It is essential in a drill grinder that the holder be so swung as to grind with correct clearance, as this one does.

work of tools, and the frequently large loss by breakage common in so many shops, is due to improper grinding. A drill with lips ground at a guess, one lip sure to be different from the other, as is unavoidably the case when it is ground by hand, even by an experienced workman,



clearly goes into its work with conditions favorable to breakage and with every probability that the holes produced will be imperfect. Milling cutters, lathe tools, and the like, of course are from their forms less likely to breakage under strains; but inequalities in cutting edges, especially so in the teeth of milling cutters, core reamers, and the like, inequalities inevitable in hand grinding, very evidently will show up in the surfaces they leave behind. Furthermore, they tend to promote chattering. It should be obvious, therefore, that hand grinding has no place in any well-regulated large shop, except possibly for roughing tools down to approximate size, and that the precision above recommended is none too great to insure the highest efficiency in high-speed tools.

**Grinding Equipment.**—As to the number and kind of machines to be installed, this naturally would depend largely upon the quantity and

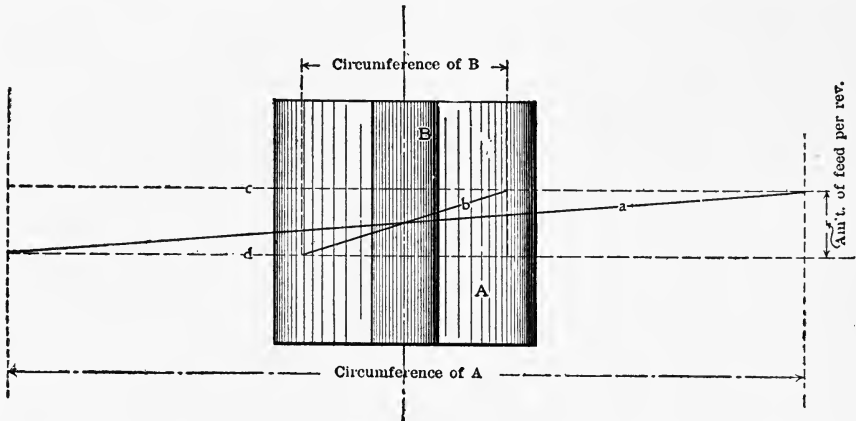

FIG. 104. How the clearance of a drill increases from the periphery toward the center.

Suppose *A* and *B* represent cylinders corresponding in diameters to any two points in the cutting lip of a drill, and *c* *d* the feed or advance per revolution, for the sake of clearness much exaggerated. The angles made by the lines *b* and *a* then represent the clearance required at the selected points. Courtesy of Wilmarth & Mormon Company.

kinds of tools used. In a shop of any considerable size it is likely that at least one drill grinder would be required, preferably one easily adapted to the grinding of all sizes used, unless there be work enough to keep more than one machine busy.

Most drill grinders now offered conform to the two prime essentials — freedom from vibration, and adjustment for maintaining uniform lip angles and curves at the points, for all sizes to be ground. It is of the utmost importance in grinding drills that the clearance angles along the entire length of the cutting edges be uniform; otherwise the clearance at some points will be too great, and at others too slight, as is shown by the annexed Fig. 104. In order to accomplish this, the drill holder must be so devised as to swing through a curve corresponding to the required clearance angle.

Since lathe and like-shaped tools form by far the larger portion of the tools in most shops, a universal machine adapted to grinding these tools is generally essential. Milling cutters can be ground successfully only in a machine designed for the purpose, or by the use of attachments to other grinders providing the requisite fittings and movements. In small shops such a combination machine, say like the one illustrated at Fig. 107, is well calculated to take care of all kinds of work. Some of the more expensive universal grinders likewise are now provided with attachments permitting the grinding of other than rotary tools (Fig. 107).

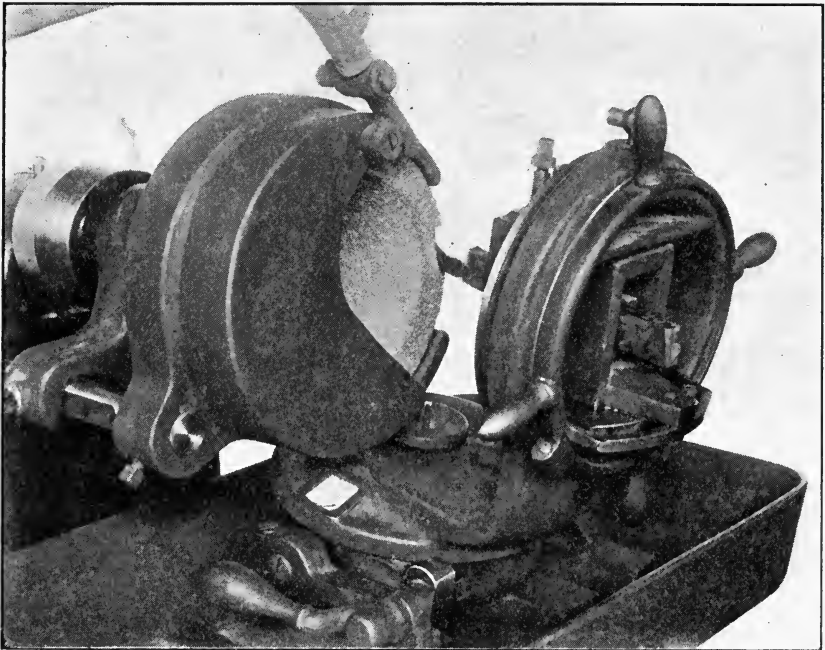

FIG. 105. A universal grinder (Gisholt) designed for sharpening lathe and like tools. All angles can be produced with certainty, and by following a chart giving the standards adopted, tools can be reduplicated indefinitely.

It is sometimes desirable to make use of special grinders for special forms of tools, whether because of the amount of work to be done or the superior adaptation of such machines to the work thus in hand. An example of such special machine is a saw grinder and a special reamer grinder, illustrated at Figs. 108, 109 and 110. Special devices in the nature of jigs can be used to a much greater extent than is now done, in grinding not only inserted cutter blades, but other tools and parts.

Cup wheels, used in common with disc grinders on other forms of tools, are required for most rotary cutters, since this shape of wheel allows the proper facing and backing off of spiral and other difficult shapes of cutters. The cup wheel gives a straight clearance or land instead of a



FIG. 106. Wilmarth & Mormon Company yankee drill grinder, with attachment for universal grinding. Very desirable in a small shop with a considerable range of tool grinding work.

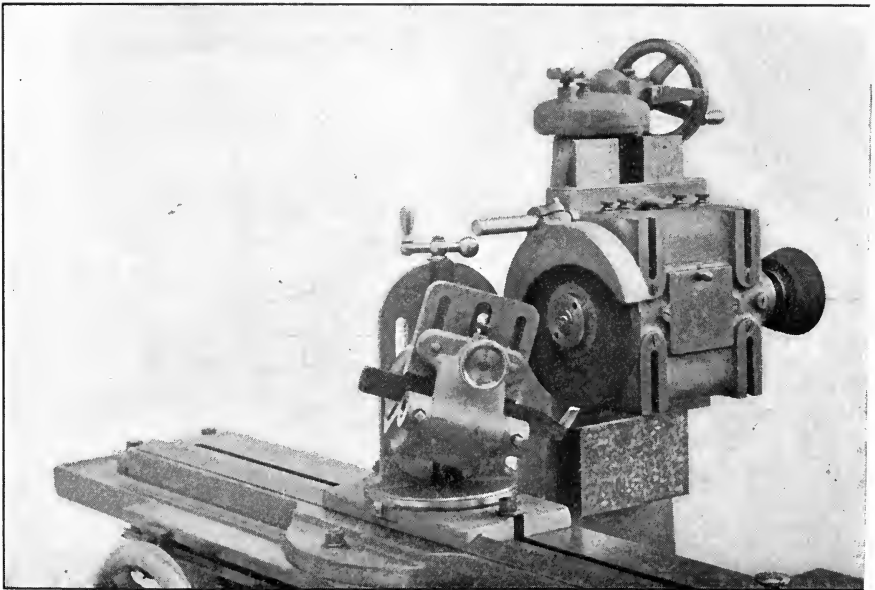

FIG. 107. In shops using relatively few tools, a grinder resembling this Brown & Sharpe machine is very desirable, since it is available for practically all classes of tools, including those of the lathe and planer class.

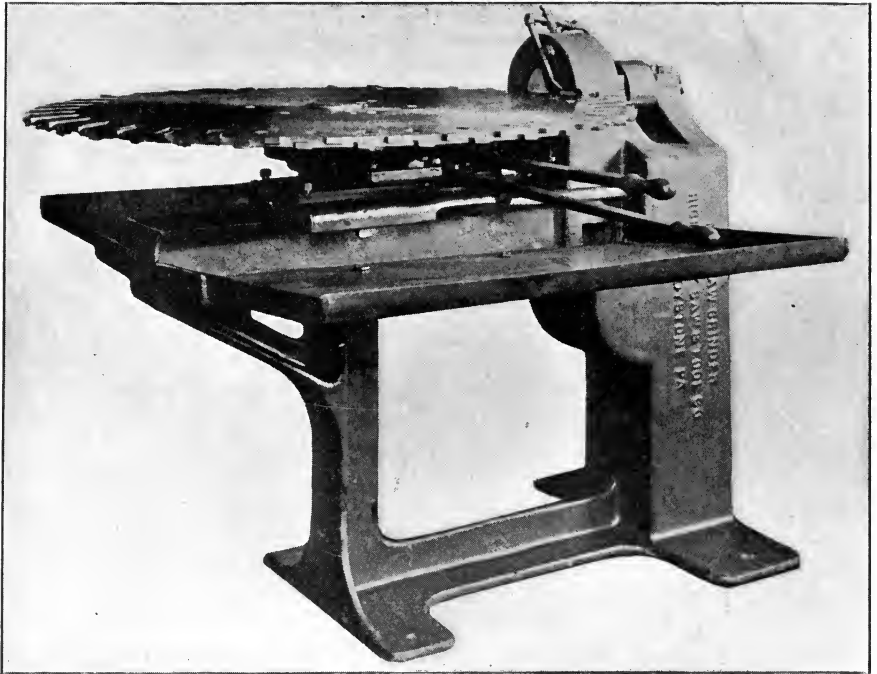

Fig. 108. A special grinder for the Tindel inserted tooth metal saw. Saves frequent readjustment of a universal machine used for other purposes.

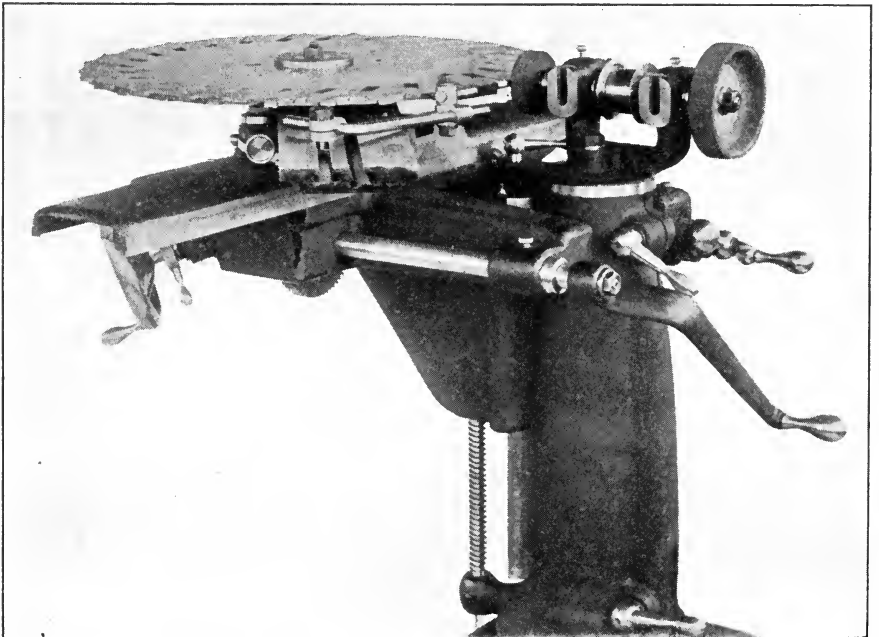

Fig. 109. Sharpening a Tindel saw on a Le Blond universal grinder.

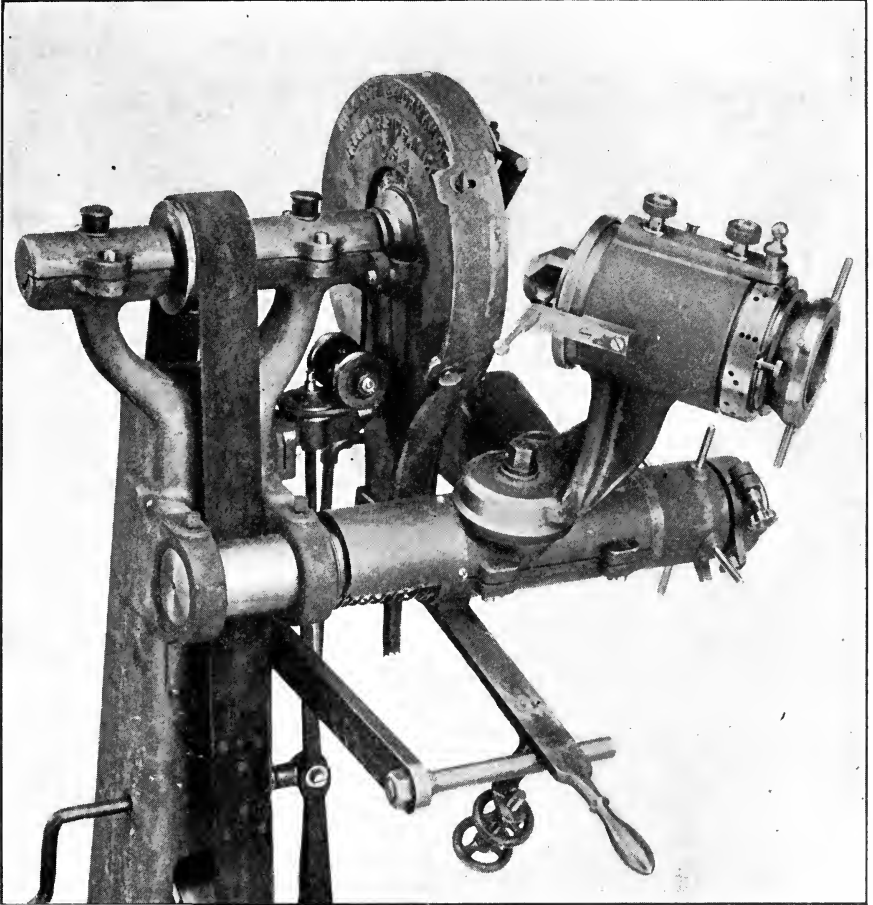

FIG. 110. Grinding a rose reamer on a special machine.  
This is the economical method of doing such work where many tools of the kind are used.

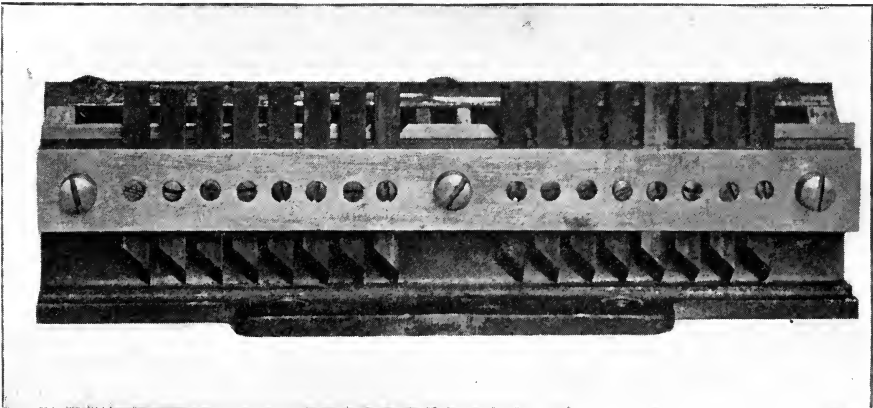

FIG. 111. Grinding jig designed by William G. Thumm. Especially adapted for grinding inserted cutters for a large face mill.

curved one, such as is obtained (unless unusual precautions are taken) when tools are ground on the periphery of a disc wheel. This method of grinding, by the use of cup wheels, therefore not only does not undercut the edge, but leaves it in the best possible form and condition for effective work and maximum life per grinding.

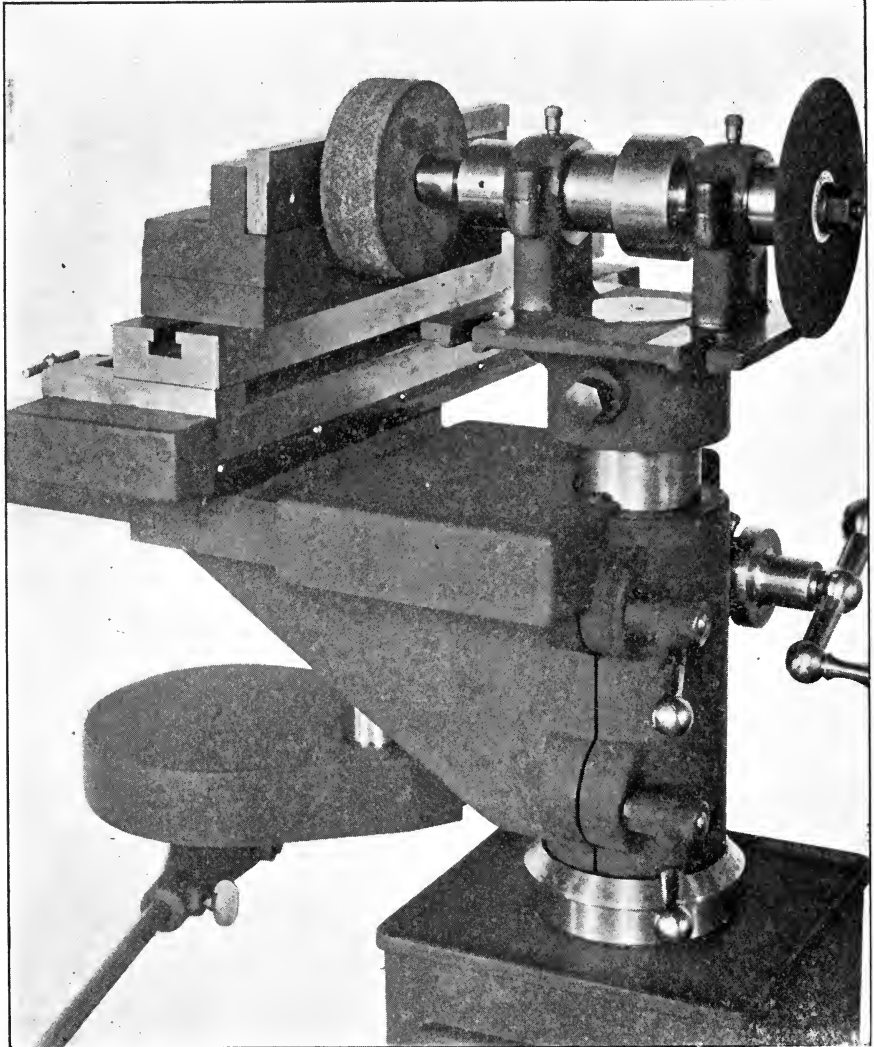

FIG. 112. The cup wheel has decided advantages in certain kinds of work, as in edging a shear blade, requiring a flat land or surface behind the cutting edge.

**Conditions to be Avoided.**—Some grinding machines are provided with positive feed devices for forcing the tool against the wheel. There is no objection to this arrangement if the feed be light, as already recommended, and if provision be made at the same time for moving the tool

or wheel in such a way that one passes across the face of the other to a greater or less extent during the whole time of the grinding. If tool and wheel face maintain the same relative position, even with a light feed, the chances are that they will quickly come to fit against each other very closely. The cutting face of the wheel then gets smooth, the grinding proceeds slowly or entirely ceases, and the tool rapidly heats up, just as if the wheel were glazed — which it sometimes is under these circumstances. Such a condition is most likely to occur when the face of the tool is rather large, and in this case especial care is to be observed when grinding with a flat surface. Grinding across the face with the angle of a wheel having a V-shaped instead of a band periphery, eliminates this trouble, though perhaps it somewhat reduces the rapidity of the work and at the same time leaves a face more or less curved according to the diameter of the wheel, as is the case always in grinding on the

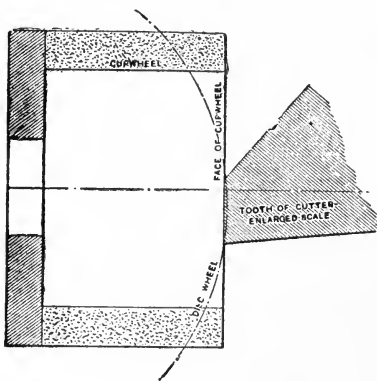

FIG. 113. Effect of grinding with disc and with cup wheels.

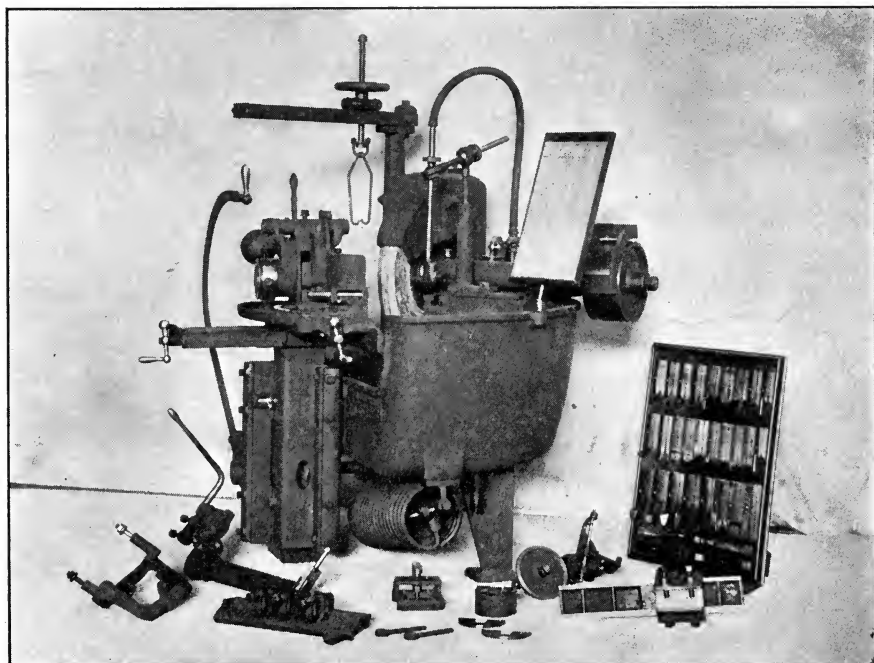

FIG. 114. Sellers grinder for flat-face tools. The wheel with a V-shaped periphery has certain advantages.

periphery of a wheel. The method makes it possible to flush thoroughly, a difficult thing to do in flat grinding. When a relatively large surface presses against a wheel surface, very little, if any, fluid gets between; so that the purpose of flushing is in large measure defeated.

**Wet vs. Dry Grinding.**—As to the respective merits of wet and dry grinding it does not seem safe to hazard a square statement. Many have found, or think they have found, wet grinding advantageous; and many others seem to have a contrary experience. The purpose of wet grinding of course is to cool the tool and therefore to allow more rapid work; and incidentally to eliminate dust. With suitably hooded machines the dust is effectually removed; and it is a question if the damage often done tools in wet grinding does not much more than offset the possible increased speed. If the amount of water thrown against the tool is very large and the stream is closely confined to the place where the work is done, there is considerable gain in large work. There is, however, the practical difficulty of forcing water between wheel and tool surfaces where it can keep the face cool, all the greater because the amount should be large, but the speed of delivery slow; and it is doubtful under these circumstances if the liability to checking by reason of the contact of the water with the at times over-heated surface does not do more damage than good. However that may be, wet grinding is very largely practiced in connection with large and simple tools, especially where the surfaces to be ground are more or less rounding rather than flat. On such work as milling cutters, reamers, drills, and the like, dry grinding seems preferable; and indeed few machines are designed for wet grinding of these types. The sandstone, if used, must run wet; and this is a good reason why it is best left alone for much, if not all, grinding of high-speed tools.

**Oil for Cooling—Nozzles and Hoods.**—Modern emery or composition stones are not affected by oil, when well soaked, and do not, so far as reported, have their cutting qualities impaired. It would therefore seem that if oil were used for flushing in grinding all classes of high speed steel tools, all the advantages of wet grinding would be obtained, with none of its disadvantages. The very considerable waste from "spattering" could no doubt be eliminated by suitably constructed nozzles and hoods. All grinders should be hooded anyway; and as for nozzles, until recently nobody seems to have thought it worth while to use anything other than a piece of pipe. With some attention to these points oil grinding would seem to promise much in this new field.

**Grinding Before Hardening.**—Whatever may be the several opinions respecting sandstone and emery wheels, and dry or wet grinding of hardened tools, the kind so far under consideration, it seems to be pretty generally agreed that for pre-grinding, that is, for grinding before hardening, a dry emery wheel is most satisfactory. With a soft or open and



coarse wheel, material can be removed with great rapidity and without danger of harm to the tool. Sometimes the tool is ground while still hot from the forging heat; and indeed this is recommended where convenient. It is no disadvantage even though the tool be still red hot.

The advantage of thus pre-grinding manifestly is that the tool is still soft, and the reduction is much more rapid than after it has been hardened.

#### **Metal to be Removed in Grinding.**

The finish grinding obviously need be relatively slight. This refers to the surface of the tool in general; for at the cutting edge the finish grinding, when rough grinding precedes the hardening process, must be severe, if the full efficiency of heavy

tools is to be developed. It is

a matter of remark among the users of high-speed tools that in general they do not work up to their highest possibilities until after two or more grindings. The reason is simple. The high hardening temperature to which they are subjected affects the sustaining power, especially at the cutting edge, where the danger of "burning" the steel is greatest. Evidently a tool will dull or break down much more rapidly when any portion of the injured skin remains than when this has been removed; and quite evidently also the tool must either be ground several times in the customary manner, or the burnt portion must be removed by a severe single grinding, in order to bring out its full possi-

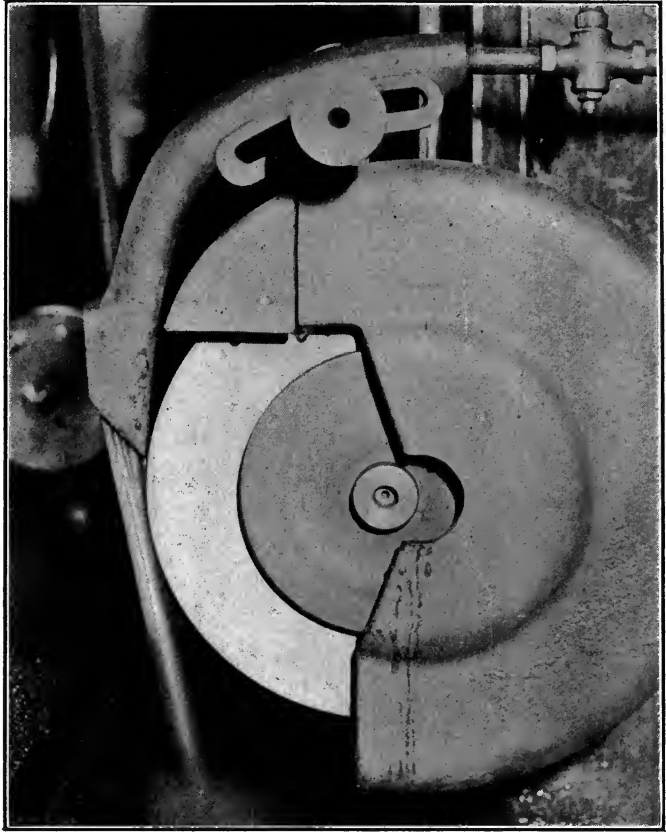

FIG. 115. The "Wizard" nozzle prevents the spattering common when ordinary forms are used.

bilities at the first use. On lathe, planer, and similar tools,  $\frac{1}{16}$  inch is ordinarily none too much to grind off the cutting edge the first time; and on large tools rather roughly forged, more is desirable. On fine cutters with keen edges, hardened at a somewhat lower temperature, no such heavy first grinding is necessary. Ordinarily such tools are set at work without grinding subsequent to hardening.

**Direction Wheel Should Run.**—Carbon steel tools are ground with the wheel running toward or from the cutting edge, at the fancy of the

grinder usually; and good edges can be secured either way — provided, in the second case, the burr be removed by honing. High-speed tools are preferably ground with the wheel running against the cutting edge, most grinders being in this way able to get better results. It is not desirable that the grinding face be run along a cutting edge,

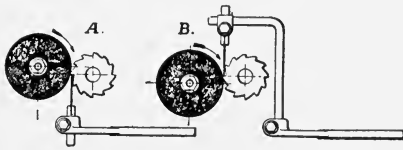

FIG. 116. High-speed tools are best ground by revolving the wheel against the cutting edges, as show in *B* above, rather than with the teeth, as in *A*. The former method prevents burring and allows faster grinding. The cutter must be held firmly against the rest, by hand or otherwise.

though in certain cases this may be unavoidable. Revolving cutters, when so ground, that is, with the wheel rotating against the cutting edge, need

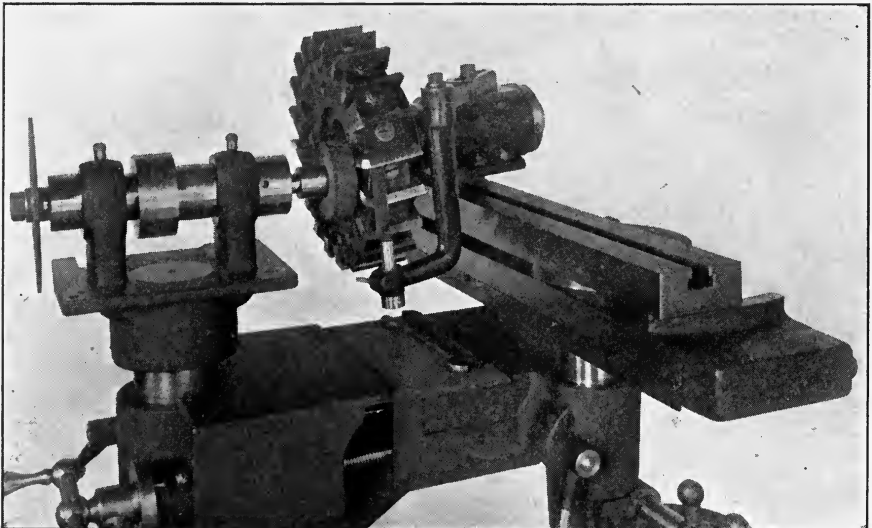

FIG. 117. Customarily the cutter is held by hand against a guide. Especially when used in taking finishing cuts, it is better that the cutter be held in place mechanically.

to be rigidly held against the tooth rest; otherwise there is likelihood that they may be drawn out of proper position by the wheel, and the teeth scored and the wheel damaged or even broken. The usual method

is to hold the tool by hand against a guide. This is liable to permit more or less unsteadiness and consequently eccentricity in the periphery of the cutter. Holding and rotating the cutter mechanically is much to be preferred, particularly if it is to be used for finishing cuts.

**Amount of Water Required.**—It seems scarcely necessary to point out that a tool started either wet or dry should be finished without change. In hand grinding dipping the partly ground tool into water for cooling is almost sure to damage it. In wet grinding the water supply must be much more liberal than is usually allowed. The flow need not, and indeed should not, be very rapid; but the volume delivered from the nozzle must be, for ordinary grinding, enough to flood completely the tool—say from five to ten gallons per minute. A discharge area equivalent to that of a  $\frac{3}{4}$  inch pipe, therefore, is none too large, and for big tools is not large enough.

**Keeping Tools Sharp.**—Because it is possible to force high-speed tools even when dull, it is a common practice to run them longer without re-grinding than is economical—to run them, in fact, until the edge breaks

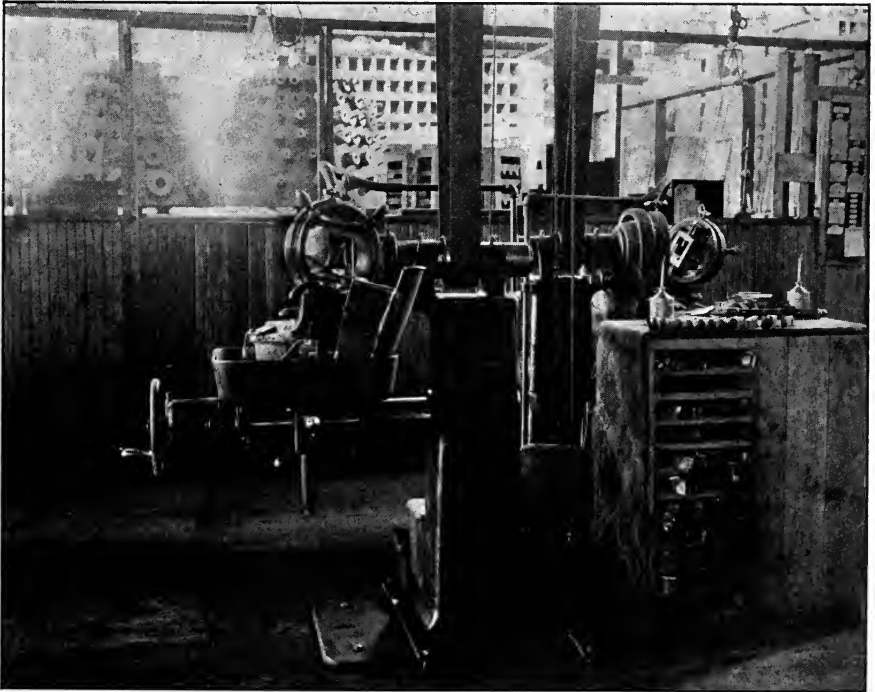

FIG. 118. Grinders in connection with the stock room. This is a very convenient location for grinders, the work being done by those connected with the tool or stock room.

down or the product passes beyond the limits of required accuracy. The maxim "keep your tools sharp" is as applicable in the case of

high-speed as in that of ordinary tools; though the consequences of disregarding it are perhaps less noticeable when the tools are used in connection with strictly modern machine tools. If used in machines not especially designed for them, the observance of the caution is a matter of great importance; otherwise the wear on the machine and effect upon the work is very marked. Furthermore, if the tool is not ground as soon as it begins noticeably to dull, the dulling thereafter proceeds at an increasingly rapid rate on account of the machine giving under the increased strains and the consequent augmentation of the chatter, which latter is at the bottom of most of the wear or breaking down at the cutting edge. In the end, therefore, it is better to grind oftener, remove less metal per grinding, and keep the tools keen. This will almost wholly obviate the need for fettling tools in the forge shop, particularly if they have been properly designed in the first place to provide for the removal of many successive layers at the cutting end before requiring forging to shape again.

**Re-grinding—Finding Cracks.**—In re-grinding tools, either because dulled or because of damage sustained in a previous grinding, the amount of metal removed should be commensurate with the condition of the cutting edge or tool surface. If the tool has been damaged by overheating in grinding, the part to be ground away most generally will need to be at least  $\frac{1}{8}$  inch, and may need to be two or three times as deep. Checks are exceedingly difficult to discover, and usually pass unnoticed until the tool breaks down at work. Mention is made hereafter of a method whereby they can usually be detected.

**Land vs. Face Grinding.**—When re-dressing a dulled tool it is desirable, for the most part, to grind both lip or face, and clearance or back, most of the material removed preferably coming from the latter surface. As tools of the milling cutter type usually wear, a given depth removed from the back will give a result equivalent to that produced by removing two or three times as great a depth from the face. Grinding the back also serves to preserve perfectly the contour of the cutting periphery. The life of such cutters is therefore considerably prolonged in this way.

**Tool-Room Organization.**—The methods and precision here indicated as essential to economical grinding for highest efficiency, imply the standardization of the tools used in a shop, as far as possible; and the organization of the tool supply on a basis which relegates all grinding to a department or to departments suitably equipped for first-class work, and manned by operators skilled in that especial work and trained to the observance of all details of design in particular tools as well as the methods to be followed in the actual grinding operations. The organization of a tool-supply department can be very simple, and indeed should be so. The prime requirements are proper equipment and operation,

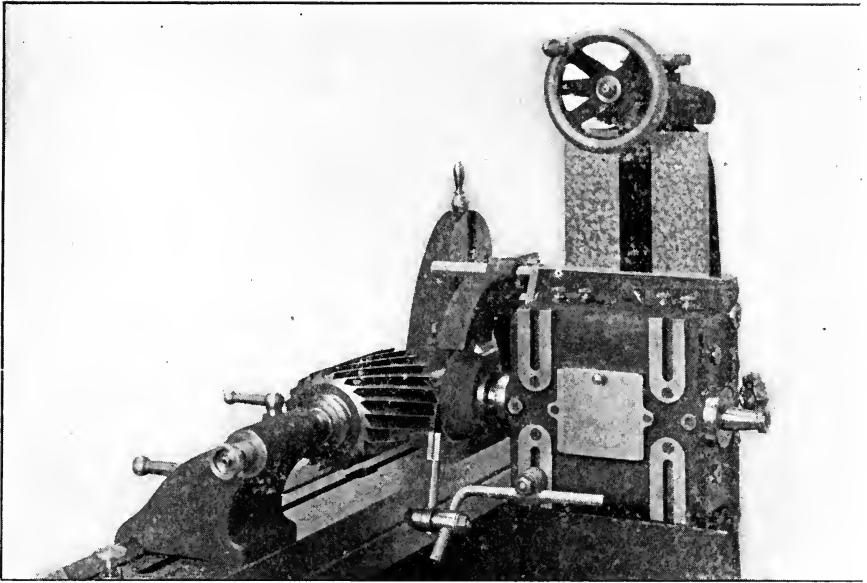

FIG. 119. The difficulties formerly attending the accurate grinding of spiral milling cutters have been pretty well eliminated in several recent universal cutter grinders. A cup wheel grinding the land back of the cutting edge.



FIG. 120. An expensive method of grinding high-speed or any other tools, viewed from whatever point.

ROUND NOSE ROUGHING TOOLS							
FOR LATHES & PLANERS.				DRAWING No 22503 SUPERSEDING No 19598			
<b>BLUNT TOOLS,</b> FOR CAST IRON & HARDER GRADES OF STEEL.				<b>SHARP TOOLS,</b> FOR WROUGHT IRON & SOFTER GRADES OF STEEL.			
TO GRIND TOP FACE ADJUST MACHINE AS FOLLOWS:				TO GRIND TOP FACE ADJUST MACHINE AS FOLLOWS:			
FOR STRAIGHT TOOLS.				FOR STRAIGHT TOOLS.			
RIGHT HAND		LEFT HAND.		RIGHT HAND.		LEFT HAND.	
HORIZONTAL ANGLE	97 $\frac{1}{2}$ '	HORIZONTAL ANGLE	97 $\frac{1}{2}$ '	HORIZONTAL ANGLE	97 $\frac{1}{2}$ '	HORIZONTAL ANGLE	97 $\frac{1}{2}$ '
VERTICAL ANGLE	104'	VERTICAL ANGLE	76'	VERTICAL ANGLE	112'	VERTICAL ANGLE	68'
FOR BENT TOOLS.				FOR BENT TOOLS.			
RIGHT HAND		LEFT HAND.		RIGHT HAND.		LEFT HAND.	
HORIZONTAL ANGLE	103 $\frac{1}{2}$ '	HORIZONTAL ANGLE	103 $\frac{1}{2}$ '	HORIZONTAL ANGLE	107 $\frac{1}{2}$ '	HORIZONTAL ANGLE	107 $\frac{1}{2}$ '
VERTICAL ANGLE	98 $\frac{1}{2}$ '	VERTICAL ANGLE	81 $\frac{1}{2}$ '	VERTICAL ANGLE	105 $\frac{1}{2}$ '	VERTICAL ANGLE	74 $\frac{1}{2}$ '
TO GRIND END FACE USE FORMER (A) AND MAKE HORIZONTAL ANGLE OF ADJUSTMENT 96° WHEN FACE IS FINISHED INDEX FINGER OF END GAUGE SHOULD POINT AS FOLLOWS:							
SIZE OF TOOL				SIZE OF TOOL			
INDEX FINGER SHOULD POINT TO				INDEX FINGER SHOULD POINT TO			
$\frac{1}{2}$ $\frac{3}{8}$ $\frac{1}{2}$ 1   1 $\frac{1}{4}$ 1 $\frac{1}{2}$ 2'				$\frac{1}{2}$ $\frac{3}{4}$ 1   1 $\frac{1}{4}$ 1 $\frac{1}{2}$ 2'			
3   5   7   11   15   19   27				2   4   6   10   14   18   26			
STRAIGHT TOOL RIGHT HAND				STRAIGHT TOOL LEFT HAND.			
BENT TOOL RIGHT HAND				BENT TOOL LEFT HAND.			

FIG. 121. Part of direction sheet used in connection with Sellers' grinder. With a sheet thus showing standard forms and angles before him, the tool grinder is able to reproduce exactly a tool edge an indefinite number of times.

as stated; standard designs of tools for practically all jobs, all details for each tool being definitely determined and carefully observed; and an ample supply of tools, sufficient to permit machine operators to replace dull tools without loss of time. The latter are at convenient times returned to the supply department in exchange for sharp ones. The tools are ground in batches, as these accumulate, to save too frequent changes at the grinder. The man in charge of the grinding, of course, is provided with a set of standard samples and a chart indicating the precise form and angles for each tool. This being carefully followed, the difficulties arising from hand grinding, such as varying angles, unsymmetrical cutting edges, improper backing off and relief, and the like, are entirely absent, and tools not only work more effectively but last a great deal longer. The fixed charges on the investment represented in such an equipment and ample tool supply is not comparable to the economy effected. The conditions of course apply with equal force in the case of ordinary tools; and the method of handling the re-grinding would be the same for both.

## CHAPTER XII.

### DETERMINING AND REGULATING TEMPERATURES IN HIGH SPEED STEEL TREATMENT.

**Reproducing Determined Conditions.**—Guesswork is not consistent with modern industrial methods. Rough approximation is uncertain, and therefore wasteful. It has, of course, always been true, but only in recent years has it come to be well understood, that the physical and chemical changes involved in so many productive industries take place under definite and constant conditions. Variation in conditions, whether it be in burning coal under a boiler, conducting an electric current, the heating of a baking kiln, the treatment of a tool, or what not, involves variation in the nature or efficiency of the product; and in consequence also it involves waste. The conditions of maximum effect once definitely determined, it is of the first importance in nearly all industrial operations that they be reduplicated within the established limits, with certainty and economy. The manufacture of high speed steel tools forms no exception; on the other hand the accurate gaging and reduplication of temperatures, especially high temperatures, is an absolute essential to anything approaching the maximum efficiency in tools.

**The Eye not Dependable.**—Formerly a prime qualification of a successful toolsmith was the possession of a well-trained eye, the ability to discriminate sharply the colors through the wide range seen in the heating of a piece of steel — this, that he might gage with more or less accuracy the heat to which the tools of various steels and for different uses were to be raised when hardening or tempering. Not that the color scale had for him (usually, at any rate,) any definite relation to specific temperatures, but rather because it was known to be more or less definitely related to the hardness and lasting quality of steel tools, the relation depending a good deal upon the particular steel used, and perhaps also upon other conditions. No matter how skillful a toolsmith might be, however, his tools, carefully made as nearly uniform as might be, still turned out varying more or less in quality. As we now know, this of course is just what might be expected under the circumstances. Until lately nothing was known of the critical or recalescence points in steel, the precise location of which in the temperature scale must be known before the proper heat for any particular steel can be determined. Even

if they had been known, their precise location by reference to the colors as perceived in a piece of steel by the unaided eye, would have been practically impossible. This is due not only to the difficulty of discriminating between the colors of a radiant body when those colors do not vary greatly, but even more to the personal equation of the observer and the variation in the conditions under which the observations are made.

**Elements Making for Uncertainty.**—Not only do persons differ as to just what is, say bright red or light yellow, or any other color for the matter of that; but in the same person the judgment will vary with his freedom from fatigue, his physical condition, and even his mood. Furthermore, the light in which colors are seen modifies them to a considerable extent, so that seen in one part of a shop a piece of steel of a given temperature might appear to have one color, while in another part of the same shop it might appear several shades different. Even in the same spot in a shop the light is bound to vary a good deal according to the cleanness of the window and the condition of the weather outside. Of course when artificial light is necessarily used part of the time, the trouble is still further accentuated.

**The Personal Equation.**—The difficulties arising from the personal equation, even in the case of skilled observers, is well seen in a comparison of three well-known color scales:

TABLE VI.

Pouillet. <sup>1</sup>	Cent.	Fahr.	Taylor & White.	Cent.	Fahr.	Howe.	Cent.	Fahr.
Lowest red	525	977				Lowest red visible in dark	470	878
Dark red	700	1292	Low, dark, or } blood red }	566	1050	Lowest red visible in light	475	887
Lowest cherry	800	1472	Dark cherry	635	1175	Dull red	550	1022
Cherry	900	1652	Cherry, full red	746	1375	to to	625	1157
Bright cherry	1000	1832	Light red	843	1550	Full cherry	700	1292
Dark orange	1100	2012	Orange	899	1650	Light red	850	1562
Bright orange	1200	2192	Light orange	941	1725			
			Yellow	996	1825	Full yellow	950	1742
			Light yellow	1079	1975	to to	1000	1832
White	1300	2372	White	1205	2200	Light yellow	1050	1922
Bright white <sup>2</sup>	1400	2552				White	1150	2108
Dazzling white	{ 1500 to 1600	{ 2732 to 2912						

<sup>1</sup> Pouillet over seventy-five years ago devised his color scale, which even to this day is quoted as authoritative, though his instruments for gaging temperatures were by no means comparable with those in use to-day, and his results, or his nomenclature, at any rate, are not very well in accord with more recent scales, as may be seen in the table above.

<sup>2</sup> It is impossible, in tool-making practice, to discriminate with any accuracy the hues generally designated white.



Dependence upon the eye for the determination of temperatures, and their accurate reproduction, leads to very uncertain, and in the case of high-speed steels, rather unsatisfactory results. It is quite as evident that in the treatment of a commercial product as expensive as a complicated tool, particularly when made of a material like high-speed steel, which requires for maximum effects even more care than the cheaper carbon steel tools, adequate means for temperature gaging and reduplication are of prime importance.

**Temperature Gaging Devices.**—A good many instruments and devices have been brought forward for gaging temperatures, especially temperatures above those for whose measurement the spirit of mercuric thermometer is available. Those at present in use, which are of value in connection with industrial processes, are included in the conspectus here presented (Page 158).

**Adaptation of Gage to Purpose.**—Not all the instruments included in the table (VII) are suitable for use in connection with the treatment of steels, and some of them can be used to a limited extent only. Thus the mercurial thermometer, when of suitable form, can be used for gaging the temperature of the oil tempering bath. When so used it needs to be made of specially heavy glass, well annealed, and preferably the tube above the mercury filled with an inert gas under great pressure.

**“Sentinel” Pyrometers, or Temperature Cones.**—“Sentinel” pyrometers, or temperature cones, strictly speaking, are not instrumental, for

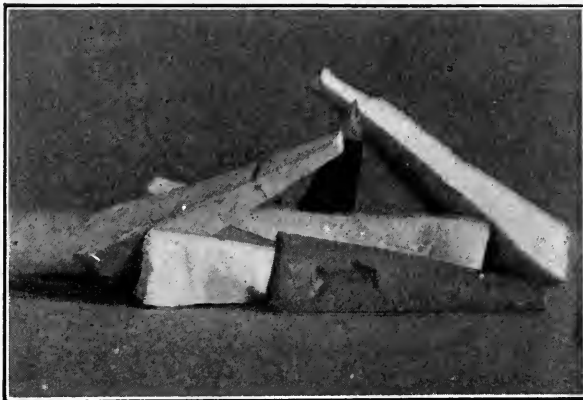

FIG. 122. Temperature determining cones, or “sentinel” pyrometers, which melt down or fuse when predetermined temperatures are reached.

there is no scale, and each cone can be used but once. They are made of metallic alloys or mixtures or earths and the like, so proportioned that when a given cone reaches a predetermined temperature it fuses or melts down. They are useful, therefore, in indicating when desired

TABLE VII.

Class.	Principle Involved.	Types.	Range Centigrade.	Range Fahrenheit.
Expansion	Variation in volume of a substance by change of temperature.	Gas	0—1000	32—1850
		Mercurial	-04—550	-100—1025
		Spirit	-210—25	-350—75
		Pneumatic, gas	low—980	low—1800
		Metal rod, etc.	low—485	low—900
		Porcelain (contraction)	low—1800	low—3200
		Water current	0—1600	0—2900
		Brown platinum	0—1600	0—2900
Pneumatic	Flow of gases thru small apertures.	Uehling	low—1650	low—3000
Calorimetric	Relation of specific heat to quantity absorbed.	Siemens water pyrometer	low—1480	low—2700
Fusion or "Sentinel"	Unequal fusibility of various metallic or earthy cones	Seger temperature cones	0—2000	32—3600
Thermo-electric	Current developed when one junction of a thermo-couple is at a temperature differing from that of the other.	Le Chatelier Hoskins Bristol Price, etc. }	-180—1650	-380—3000
Resistance	Variation in electrical conductivity under changes of temperature.	Le Chatelier	lowest attainable } 1200	lowest attainable } 2200
Radiation	Measurement of heat radiated.	Féry Bolometer }	900—1600 <sup>2</sup>	1650—2900 <sup>2</sup>
Optical	Variation in luminosity or wave length.	Morse — superposition of incandescent filament.	600—2000 <sup>1</sup>	1100—3600 <sup>1</sup>
		Le Chatelier mirror	} 500—2000 <sup>1</sup>	925—3600 <sup>1</sup>
		Féry absorption,		
		Wanner — all photometric comparison.	900—1800 <sup>1</sup>	1650—3250 <sup>1</sup>
	Mésure & Nouel — prismatic		750—1000 <sup>1</sup>	1400—1850 <sup>1</sup>

<sup>1</sup> The upper limits of some of these pyrometers are much higher than those here indicated—in some cases, as the Féry radiation instrument, and the bolometer, there is no theoretical higher limit. The ranges here given are, so far as data have been obtainable, those within which reasonably accurate results are to be had in industrial service. Certain of the instruments named are sometimes made for laboratory use with higher and lower limits. The Holborn-Kurlbaum instrument is the German form of the Morse, and its range is the same.

<sup>2</sup> The bolometer, especially in its improved form, is a laboratory instrument capable of measuring infinitesimal changes in temperature, and has an unlimited theoretical range. A change as minute as the millionth part of a degree can be measured with it. In the improved form it consists essentially of a pair of differential platinum thermometers made of very narrow strips of exceedingly thin foil, one of which is completely blacked and the other bare, both enclosed in an hermetically sealed tube. An indicator of the Callendar type is generally used.

temperatures are reached, and can be made to indicate, by using pairs selected for the purpose, the maximum and minimum temperatures within which a process or treatment must be carried on. Thus if a tool is to be heated to between, say 1025 and 1050 degrees C., two cones, one of which fuses at the lower temperature and the other at the higher, are placed in the furnace while the heat is going up. When the first cone melts down, the tool is introduced. By watching the second cone and regulating the furnace when there are signs of its melting, the temperature can be maintained within the required limits. It is well to introduce cones of the first kind from time to time so as to insure keeping the temperature above the minimum. This method of course is rather tedious, and is not permissible as a regular thing in commercial work. The "sentinels" are very useful as a check upon the regular pyrometer, and also upon the judgment of the operator when tools are hardened without such an instrument. Some sixty different grades are commercially obtainable, giving a considerable range, from about 590 to 1975 degrees C. (1095 to 3720 F.).

**"Poker" or Fire-End Pyrometers.**—The most usual method of gaging temperatures of materials undergoing industrial processes is to insert into the furnace, fire chamber, or other containing receptacle, the so-called fire end or "poker" of any one of several types of pyrometers, the temperature being indicated or recorded at a greater or less distance away (in the case of the electrical instruments), as may be expedient. In expansion instruments the indicators of course are attached directly to the stem, as in the water current and the Brown platinum pyrometers. These instruments are based on the same principle, the former having its non-platinum parts cooled by a current of water so as to adapt it for continuous use. The latter is quite durable, but is not adapted for continuous use, the stem or fire end being exposed to the furnace heat only long enough to allow the indicator to register the maximum, the instrument being withdrawn before the iron frame can be injured or the platinum impaired.

**Le Chatelier Type.**—Le Chatelier seems to have been the first to perfect an electrical heat gage, applicable to industrial processes requiring very high temperatures, in his thermo-couple electric pyrometer; and instruments of this type are most frequently used in connection with the treatment of high-speed steels. Several different makes are on the market, varying in excellence, reliability and endurance. All, however, are based on the principle that when one junction of a thermo-couple (that is, of a continuous circuit composed of two different kinds of conductor) is heated while the other remains at a constant normal temperature, a feeble electric current is set up which varies more or less regularly according to the materials constituting the thermo-couple, with the temperature to which the "hot" junction is exposed. The

current of course can be measured by means of a delicate galvanometer, and the relations between the strength of current and the temperature



FIG. 123. Le Chatelier fire end inserted in oven furnace. The indicator is at any convenient distance.

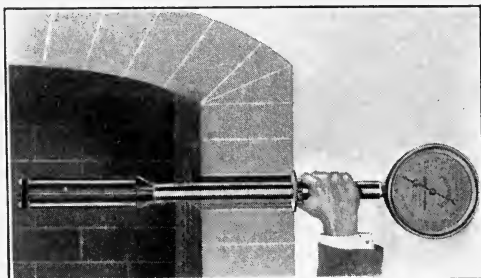

FIG. 124. Brown quick-acting platinum pyrometer, for intermittent service.

of the junction having been determined, the deflections of the galvanometer needle may be converted into temperature indications. Owing to the "extra currents" and other disturbing elements found in pairs of most materials otherwise suitable for the purpose, and likewise

because of the necessity for elements capable of withstanding extremely high temperatures, the thermo-couple material must be selected and manufactured with extreme care. Most often, for the determination of

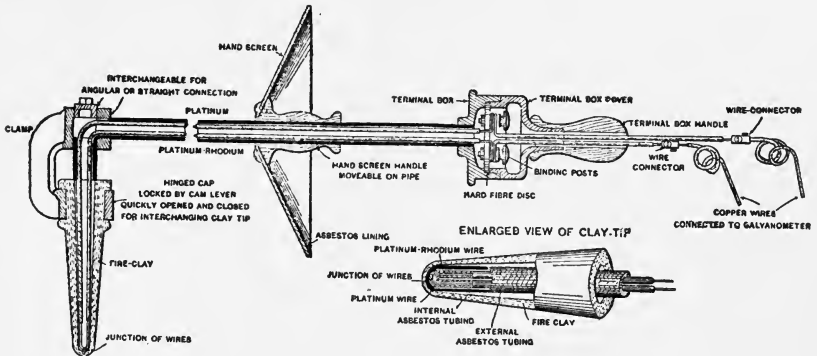

FIG. 125. Stupakoff (Le Chatelier) pyrometer outfit. Courtesy of Charles Engelhardt, New York.

such high temperatures as are involved in high speed steel treatment, the couple is constituted of platinum and a platinum-rhodium alloy, though nickel-chrome steel and other nickel alloys also are used.

**Maximum Temperature Range.**—The heat resistance of these elements is very high, making it possible to expose the instrument, when made



FIG. 126. Thermo-couple pyrometer enclosed in steel tube, and indicating instrument.

in the best form, to temperatures up to 1600 degrees C. (2920 F.) and even above, for short periods. This is considerably above any temperature required in the making of tools, 1400 degrees C. (2550 F.), or thereabouts, being the highest usually required. At these temperatures,

however, the fire ends deteriorate with greater or less rapidity, and are easily broken afterward. They are, in order to prolong their period of accuracy and permanency, usually protected by being enclosed within porcelain, fire clay or other heat-resisting material (a combination of asbestos and carborundum, in the case of the Bristol instrument); but these frequently crack and crumble, and it is necessary to check the instruments at intervals against standards of known certainty, to in-

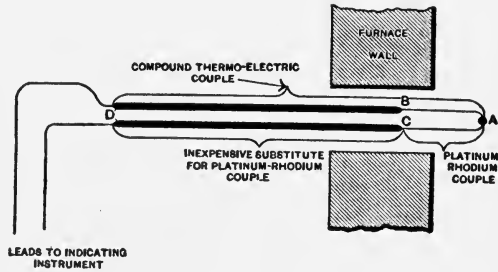

FIG. 127. Bristol compound fire end.

sure consistency in the readings, if not accuracy. It is shown hereafter that absolute accuracy, that is, the indicating of the absolute temperature, is less essential than consistency; and so, if an instrument has departed from its calibration, the variation being within reasonable limit, allowance can be made for this, provided the extent is known. When the departure has reached an amount where the indications no longer are reliable, of course the instrument must be discarded.



FIG. 128. Hoskins pyrometer with exposed couple.

**Recent Thermo-Couple Developments.**—A recent development in pyrometers of this type consists in making the fire end compound (Fig. 127),

only that portion actually exposed to the high temperature being of the precious metals. This reduces the expense of renewals considerably, while the readings are sufficiently accurate for the present purpose.

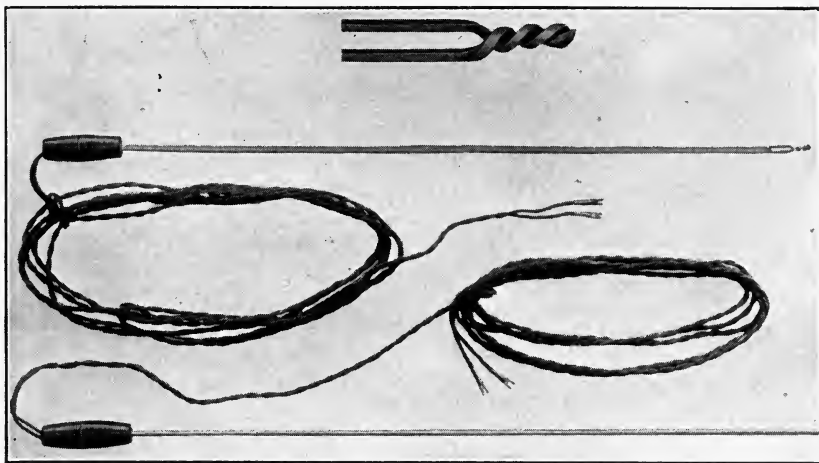

FIG. 129. Hoskins standard fire end, standard thermo-couple with handle and leads, and new nickel sheath thermo-couple complete. The fire end is made of heavy alloy wires twisted and welded.

Another development is the Hoskins thermo-couple, which is made of comparatively inexpensive alloys that withstand the required high heats

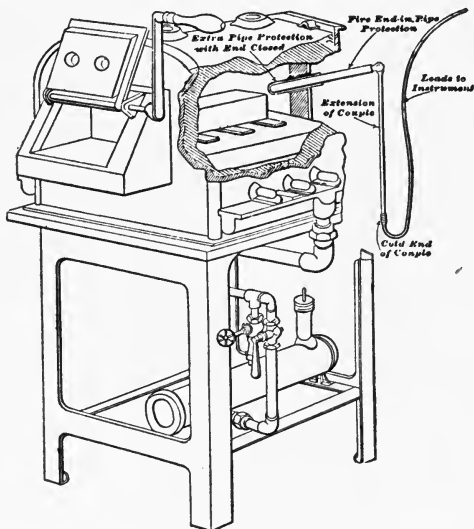

FIG. 130. Application of poker to oven furnace, and Bristol method of cold end temperature maintenance.

apparently indefinitely, while at the same time they are made of wires heavy enough to require no protection and to allow of considerable rough usage without detriment. The fire end junction being exposed

directly to the temperature to be measured without the intervention of protecting tubes or covers, responds quickly, and there is little or no lag in the indication. A modified form of this instrument has one element in the form of an asbestos-wound wire enclosed within and joined to a nickel tube which forms the other element.

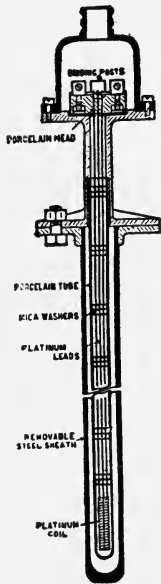

FIG. 131. Section of an electrical resistance pyrometer.

**Protection of Fire Ends.**—It is well enough, and in the case of most of these instruments necessary, to provide an iron pipe covering, perhaps of ordinary gas pipe, closed at the inner end so as to form a well, not only for the protection of the fire end, but to prevent unnecessary and often detrimental air currents.

**Cold End Temperature Compensation.**—Inasmuch also as the correct registering of the temperature under observation depends upon the "cold" end of the couple, that exposed to the normal atmospheric temperature and near the temperature for which the instrument is calibrated (usually about 25 degrees C. or 75 F.), that end should be out of the range of direct radiation of the furnace, or other sources of temperature variations. The Bristol instrument has an arrangement whereby the cold end is kept near the floor; and in case still greater accuracy is required than is thus afforded, a compensator is placed in the

circuit to preserve the calibration practically correct. Unless the atmospheric temperature varies considerably from that above given (25 degrees C.), allowance can be made for it in reading the indicator. This allowance is governed by the design of the instrument, and is usually furnished by the maker, with the instrument. At least one indicator on the market utilizes a multiple scale whereby the allowance is made automatically by reading the scale nearest corresponding to the atmospheric temperature, as shown by a mercurial thermometer provided for the purpose. Theoretically the temperature of the cold end should be at zero; and in laboratory work, and in certain industrial operations where much refinement is necessary, an "ice bobbin" is utilized for maintaining this condition. In ordinary industrial processes, such as steel hardening, where the length of the elements is sufficient to allow the cold junction to be moderately near the limits already indicated, the slight variations due to this cause may be disregarded.

**Electrical Resistance Pyrometer.**—The resistance type of electrical pyrometer is also used to some extent in hardening high-speed steels, and for all temperatures below 850 degrees C. (1600 F.) is perhaps the most accurate type, suitable especially where a very open scale is desired. It depends for its action upon the variation in the electrical conductivity



of a platinum wire or foil, according to the temperature to which it is exposed. This variation is practically constant, and when measured by an indicator constructed on the principle of the Wheatstone bridge, can be easily reduced to temperature units — or most usually, read off directly on a temperature scale to which the indicator has been calibrated. The indicators and recorders are cumbersome and much more expensive than those for thermo-couple pyrometers of the same range. The latter are better adapted to measuring high speed steel hardening temperatures because the resistance instruments will not stand exposure to the intense heats required, except for very short periods, the maximum for such short periods even being only 1200 degrees C. (2200 F.). For that matter, it is desirable that neither kind be exposed unnecessarily; and especially when enclosed in porcelain or similar protective cylinders they must be heated up rather gradually. The fire ends crumble and deteriorate rapidly enough with careful usage. Besides being unsuited for continued use at temperatures above 850 degrees C. (1600 F.), the cost of the resistance fire ends, as well as of the indicators or recorders, is very much higher than that of the thermo-couple type.



Fig. 132. Le Chatelier resistance pyrometer.

**Water Current and Uehling Instruments.**—Two other pyrometers have been used in connection with hardening high-speed tools, with good results — the water current and the Uehling pneumatic. The latter of these, however, is very expensive and has no particular advantage over the electric instruments already

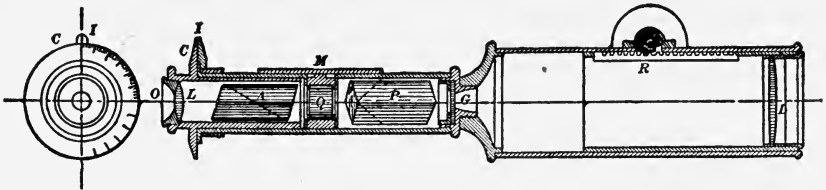

Fig. 133. Mesure and Nouel optical pyrometer.

*G*, ground diffusing glass; *P*, polarizing nicol; *Q*, quartz plate; *A*, analyzer; *OL*, eyepiece; *R*, rack and pinion; *C*, graduated circle, calibrated and reduced to temperature scale; *L*, objective.

described. Both have all non-platinum parts which are exposed to the fire, cooled by the circulation of water through or around them. Their accuracy and permanency, therefore, is much greater than that of most other forms of fire and temperature gages.

**Fire-End Deterioration — Optical Pyrometry.**—The deterioration of the fire ends is the weak point in most pyrometers of that type; and to obviate the difficulty instruments have been devised which do not

require having any part directly exposed to the high temperature sought to be gaged. These, with one exception, are of the optical type; and all utilize the energy of radiant matter transmitted to any convenient distance, in the determination of the temperature of the body under observation.

**Mesure and Nouel Pyrometer.**—Of all the pyrometers adapted to use in hardening operations, the Mesure and Nouel (Fig. 133) is perhaps the simplest, since it is entirely self-contained and has no delicate parts to get

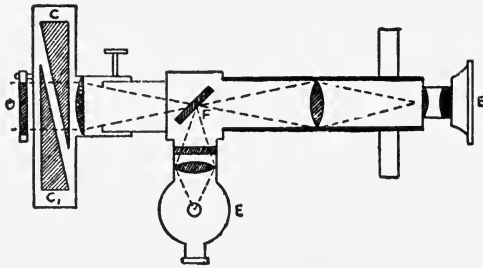

FIG. 134. Féry mirror or absorption pyrometer.

*DB*, a small telescope with *B* the eyepiece; *E*, standard lamp; *F*, mirror; *CC*<sub>1</sub>, absorbing wedges.

out of order. It utilizes the colored field produced by the polarization of light from the object observed, and the accuracy of a temperature reading or of its maintenance depends upon the judgment of relative colors, very much as when the natural colors of a heated object are viewed by the unaided eye. For this reason, among others, it is of material assistance only in the hands of a skilled operator, and even such an one cannot be sure of any accuracy within fifty or more degrees C. at temperatures above 1000 degrees C.

**Photometric Type of Instrument.**—The Le Chatelier and the Wanner optical, and the Féry absorption pyrometer each depends upon a photometric comparison of the relative brightness of the two halves of the

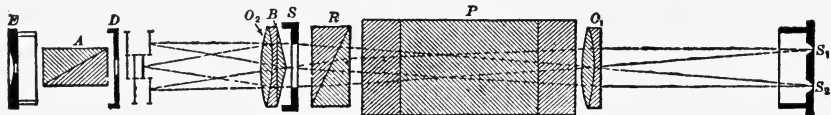

FIG. 135. Wanner optical pyrometer.

*A*, Nicol analyzer; *B*, biprism for eliminating images; *D*, slit through which images are observed; *E*, eyepiece; *O*<sub>2</sub>, lens for focusing image upon *D*; *O*<sub>1</sub>, objective; *P*, *d*-7 prism; *R*, Rochon prism; *S*<sub>1</sub>, slit for admission of light from standard; *S*<sub>2</sub>, slit for admission of light from object observed.

illuminated field, one half receiving its light from the radiant object, the other half from a standard source of light forming part of the instrument. The Le Chatelier instrument utilizes an iris diaphragm for regulating the amount of light admitted from the radiant object, in combination with a mirror and a standard source of light of known intensity, the light from the two sources each covering half the field. By adjusting the diaphragm until the two halves are of equal bright-

ness, the temperature can be calculated, or read off directly, from the scale attached to the diaphragm.

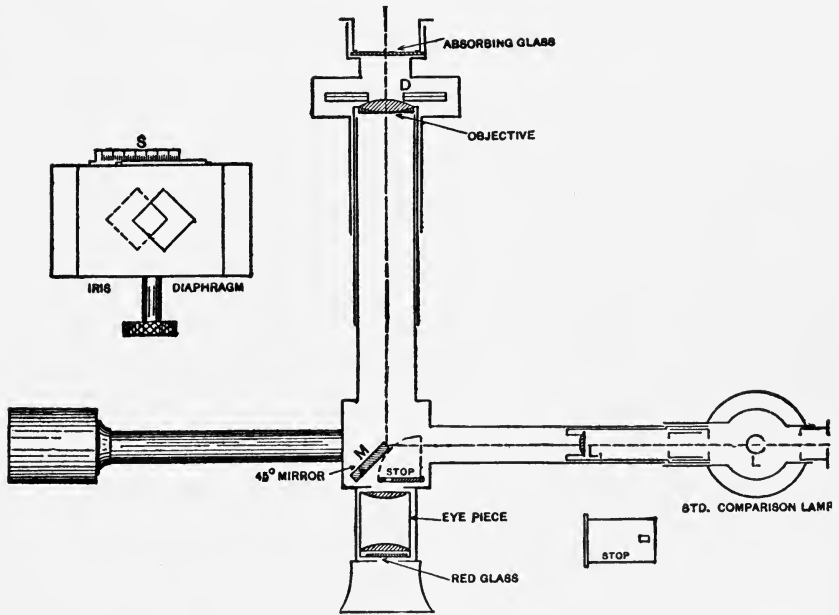

FIG. 136. Le Chatelier optical pyrometer.

Féry uses a system of absorbent wedges for the same purpose, and the reading is taken in the same way. The Wanner instrument utilizes, in combination with the standard source of light, a system of prisms and lenses for polarizing in such a way that by turning the analyzer with its attached graduated scale, the two halves of the illuminated field, one receiving light from the standard of comparison, and the other from the object observed, may be made of the same luminosity and the temperature then read off at the scale. All the above pyrometers, except the Mesure and Nouel, are quite accurate in the determination of relative temperatures within their several ranges. Generally speaking, the possible error is less than one per cent, and in some cases only half as great.

**Morse Thermo Gage.**—Perhaps the most convenient of the optical pyrometers which are accurate enough for use in connection with high speed steel treatment is the Morse Thermo Gage, made in Europe with some slight modification under the name Holborn-Kurlbaum Pyrometer. It consists of a tube, furnished with lenses if desired, within which is the filament of a small low-voltage electric lamp. In the lamp circuit is a rheostat and a milliammeter. In determining the temperature of a radiant substance it is observed through the tube, and the current passing through the filament is at the same time so regulated through

the rheostat that the filament disappears against the bright surface upon which it is superposed. The current used is indicated by the milliammeter, and this can be reduced to terms of temperature; or,

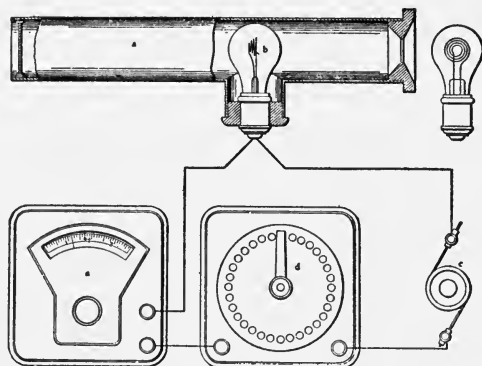

FIG. 137. The Morse Thermo Gage.

most usually, the temperature is read directly from the scale. With little practice the eye becomes very sensitive to any difference in the



FIG. 138. The Morse Thermo Gage in use. It may also be used in connection with a portable stand.

brightness of filament and the object upon which it is superposed, and temperatures can without difficulty be read with a possible error not exceeding two or three degrees C. With this instrument it is possible to prearrange the conditions for the required temperature, to know with certainty when it is reached, and to reproduce the same indefinitely. For the higher temperatures, say above 800 degrees C., absorbent glasses are provided for reducing the dazzling brilliancy of the field. With these accessories the highest temperatures industrially obtainable can be read very accurately.

**Féry Radiation Pyrometer.**—The Féry radiation pyrometer combines some of the features of the optical instruments, with a delicate thermo-couple in the circuit, with a sensitive potential galvanometer whose

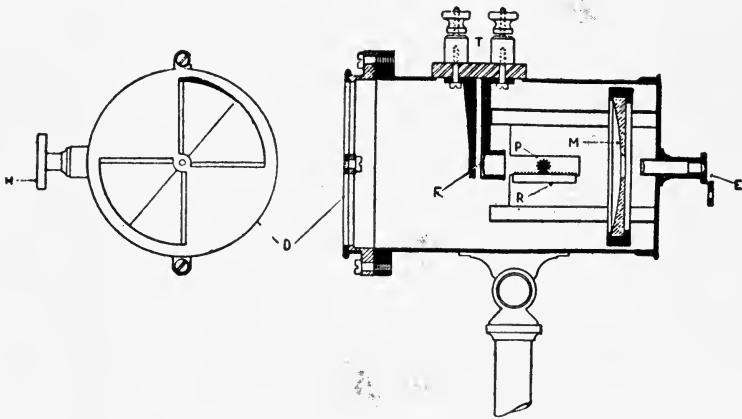

FIG. 139. Féry radiation pyrometer. Section.

*E*, eyepiece; *F*, thermo-couple; *M*, concave mirror with aperture; *D*, diaphragm; *T*, binding posts; *PR*, rack and pinion.

indications may be read in degrees of temperature. It is virtually a reflecting telescope, the concave mirror focusing the radiant heat of the object under observation upon the "hot" junction of the tiny thermo-couple. The instrument is sighted upon the object and focused by a rack and pinion at the side. There is also a diaphragm for reducing the effective aperture when the instrument is pointed at a very hot object, preventing the overheating of the thermo-couple.

**Advantages of Optical Pyrometry.**—Optical and radiation pyrometers are entirely separate from, and within limits may be at any required distance from, the source of the heat to be gaged; so that they are not at all affected by even the highest temperatures obtainable. Their permanence, therefore, and their reliability, are very great, as compared with most other forms. Distance, as is well known, does of course affect the energy of radiated heat and light waves; but within the limits usually necessitated in the kind of work now under consideration, the

loss is quite inappreciable. Thus it has been shown with a Féry radiation pyrometer that the temperature indication of a stream of molten steel was precisely the same whether the instrument was at a distance of three or sixty feet.

The comparison lights or filaments, as the case may be, where such are required, naturally deteriorate somewhat with long use; but even then



FIG. 140. Féry radiation pyrometer in use.

the falling off in accuracy is surprisingly small. It is of course desirable that these, like all other pyrometers, be checked up, compared with standards from time to time, and kept properly calibrated.<sup>1</sup>

**Calibration for Intended Service.**—It must be remembered, in using pyrometers of this class, that not all bodies radiate the same amount of energy at similar temperatures, and that there are certain definite conditions under which the indications will be correct for the object observed. For the present purpose it is perhaps sufficient to point out that an instrument calibrated for use in gaging the temperature of a furnace interior is not adapted, without re-calibration, or, at any rate, without taking into account this special factor, for use in investigating the tem-

<sup>1</sup>The Bureau of Standards, U. S. Department of Commerce and Labor, Washington, D. C., will for a moderate fee test and calibrate temperature gages when delivered at the laboratories for that purpose.

perature of a tool in the open air. The instrument must be calibrated for the intended use. Not only this, but it is necessary to take into account that these instruments are based upon the laws of radiation from a so-called "black body," whether those radiations have a long (heat) or a short (light) wave length; and that unless specially calibrated they will give correct readings only when the object under observation approximates, in its conditions, a "black body" — that is, has its reflecting power reduced to a negligible minimum. This is accomplished nearly enough, in high speed steel treatment, by observing the tools as they lie within a furnace, the temperature of whose fire-clay walls is the same as that of the tools, the observation being carried on through a relatively small opening in the furnace walls. Under these conditions the contents of the furnace no longer are seen as having separate form, their radiation being practically the same as that from the heated walls; and in practice, therefore, it is necessary only to sight the pyrometer into the furnace — remembering that the conditions are not well fulfilled unless the opening through which the temperature is to be gaged is relatively small. It is customary, in order to approximate the conditions still more closely, to insert permanently into the furnace a closed porcelain or iron tube or well of considerable length compared with the diameter, and to sight the instrument directly into the tube. This, of course, when the temperature of the furnace interior itself is desired.

**Responsiveness and Discrimination.**—The responsiveness and the power of discrimination of the Morse and Féry pyrometers especially is remarkable, though ability to determine minute changes of course depends considerably upon the personality and skill of the observer. Ordinarily, at the higher temperatures, a variation of no more than 5 degrees C. can be easily detected. The power of discrimination, therefore, is considerably finer than the absolute accuracy, which latter depends in part upon factors frequently neglected and, as already indicated, may vary from one to three per cent at those temperatures. This, however, is a matter of comparatively small moment in the hardening of tools, since absolute temperatures are more or less empirical anyway. In this book, for example, there are given certain hardening temperatures for certain classes of tools. Obviously, however, these temperatures will vary, to some extent, with the kind of steel used, and also with the operator and his pyrometer, whether that be of the optical or of some other class. The important thing is that the temperature gage shall be consistent with itself, and that data shall be recorded which will make it possible to reproduce with precision the temperature conditions found experimentally to yield the highest efficiency in the particular tools treated in an establishment.

**Lag.**—It must be borne in mind that, in so far as the methods of pyrometry here described are used in connection with high speed steel treat-

ment, or in the treatment of other tools, for the matter of that, the temperatures observed or recorded are those of the atmosphere or bath surrounding the tools, and not necessarily those of the tools themselves. Optical and radiation pyrometers of course can be sighted directly upon

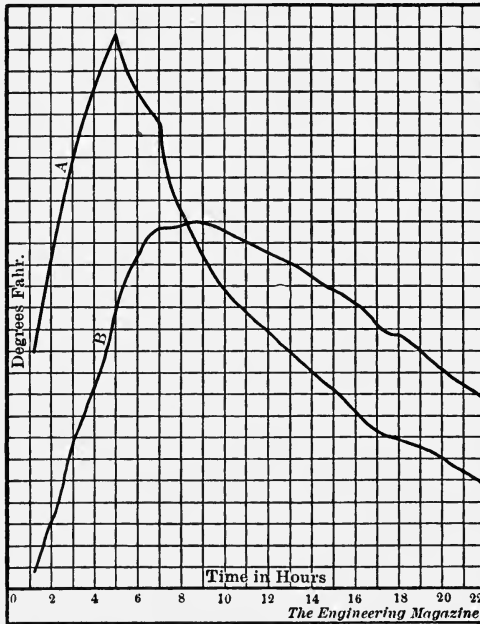

FIG. 141. How the temperature of the annealing pot interior lags behind that of the furnace. Similarly the temperature of the interior of a tool lags behind that of the exterior portions. A, temperature of furnace; B, of annealing pot in interior.

the tools, when contained in a furnace; and "poker" pyrometers are to be had with exposed fire ends drawn to fine points which may be placed against the surface of the tool under observation and its surface temperature in that way be measured directly. Such methods, however, are not necessary, and usually are not employed in tool-making. Anyway, the interior temperature of a tool could not be determined in any such manner, for the surface and the interior heat conditions could easily be different. It is sufficient to remember that time must be given for the tool to acquire throughout its mass, or at any rate throughout that part to be heated, very nearly the temperature of the furnace or bath. The larger the tool, of course the greater the lag. This is particularly important in annealing tools packed in boxes and the like, in which case the lag may easily be sufficient to prevent proper annealing, even after a long heat. The safest procedure when such work is undertaken is to make provision for inserting a pyrometer "poker" into the annealing box. A pipe well, such as has been mentioned before, is easily arranged and answers the purpose. This would, of course, be so placed relative to the regular furnace well, or some other convenient opening, as to



permit inserting the "poker" with little trouble and without much exposure to the direct heat of the furnace itself.

**Selection of a Pyrometer.**—The kind of temperature gage adopted in a hardening plant will naturally be largely a matter of personal choice and the permissible cost, as well as of the particular work required. Where the cost of the installation is not closely limited it will usually be desirable to have at least two different types of pyrometer — say an optical or radiation, and a thermo-couple; this not only in order that one may be used as a check upon the other, but because of the greater

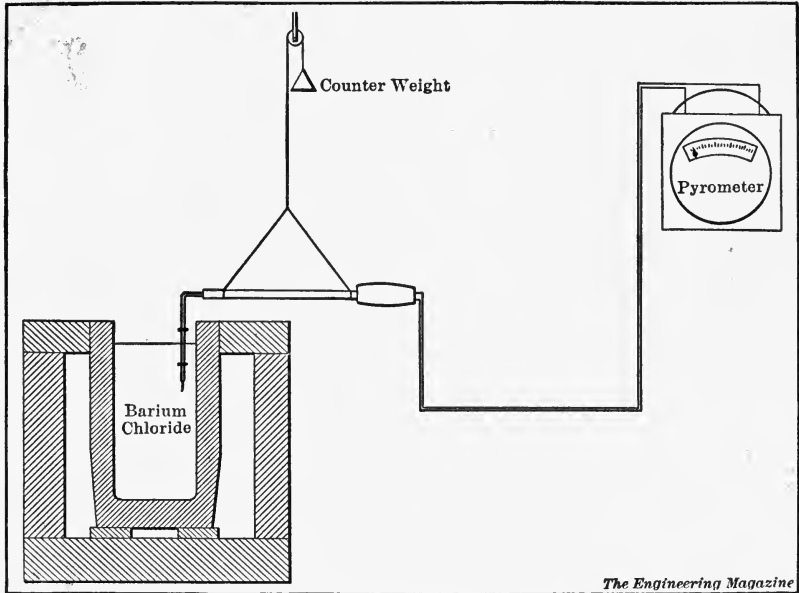
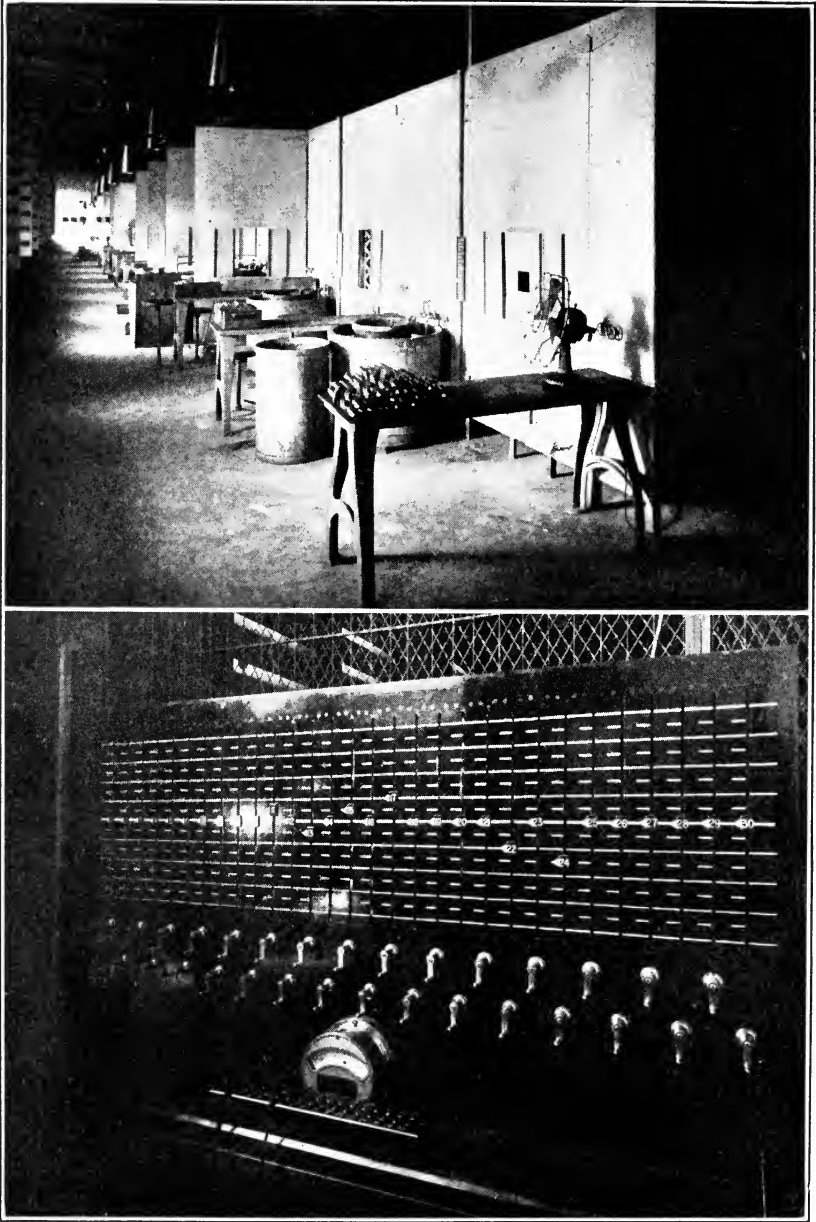

FIG. 142. Suggestion for use of pyrometer with barium-chloride hardening bath, for which optical instruments are not well suited.

convenience of one or the other for certain kinds of work. The optical instrument, for example, has been already said to be unsuited for gaging the temperature of the barium bath, unless specially calibrated for that purpose.

**Indication at a Distance.**—None of the optical instruments, it seems, has yet been provided with an indicator capable of being used at a distance and automatic in its action. Such an arrangement frequently is very desirable; and where the plant is large, the indicator and switch-board are important features of the equipment, permitting the supervisor of this work to be informed at will of the condition of any or all furnaces in operation. This is easily possible with the electrical pyrometers. Each furnace can be, at small expense, fitted with a "poker" capable of being switched into the indicator circuit at will, or connected with its own indicator or recorder, as the case may be. In some instances



FIGS. 143 and 144. Pyrometer indicator, switchboard and indicator board showing required temperature at each furnace and temperature found.

The switchboard is shown below. Turning the proper crank sets the pointer at any furnace front to correspond with that at the board. An electric bell is rung at the same time to attract the operator's attention. The indicator at the furnace is shown in the upper view. The apparatus is that devised and used by the Standard Tool Company, Cleveland.

it is desirable that the instrument be in a circuit with an indicator for use by the operator, and with a recorder in the office for the use of the supervisor and for furnishing permanent records for future reference.

**A Temperature Regulating System.**—A system for observing and maintaining temperatures in a large battery of furnaces, something on this plan, is in use in at least one large commercial tool-making plant. Each furnace, of whatever kind, is provided with a thermo-couple "poker," and all are wired to a switchboard, from which each is in turn cut into the circuit of the indicator (a recorder also could be in the circuit, if proper provision were made) and its temperature observed by the person attending to this. If not at the standard temperature required in the work then in hand, that is to say, if more than five degrees off, a crank is turned which at the same time indicates the temperature upon the board above the gage and upon an indicator board placed immediately in front of the furnace. The operator, warned by a bell, notes the temperature and regulates the furnace accordingly. The indicator boards are made so that the center line always shows the standard temperature required for the work being done. This arrangement does away with the need for separate indicating instruments for all the furnaces, but obviously requires the continuous services of some one to attend to the matter of temperature regulation alone. It has the further advantage of relieving the furnace operator of the distraction occasioned by frequent readings of the pyrometer when he has to do this himself. In a small plant such an arrangement of course is not feasible, and some simpler means are necessary. In general, one indicator is sufficient for a small plant, though it is very desirable that a recording indicator be also a part of the installation — both, of course, designed and calibrated for the pyrometer used. These can, if desired, be fitted with alarm contacts capable of being set for any required maximum and minimum temperatures. The indicator or recorder boom, on passing the contact, automatically rings a bell at short intervals as long as the temperature is outside the limits set. Such a device will result in a much closer regulation, usually, where it is necessary to work very near to a given temperature.

**Value and Forms of Records.**—Records of this sort are more important than might at first be thought. It is a well-established fact that any operator, whether working on high-speed tools, firing a steam boiler, or at any other work requiring the maintenance of uniform temperatures, will more carefully regulate his furnace and take greater care to preserve uniformity if he have a continuous record staring him in the face and constantly reminding him of departures from the required standard, than he will without such a record, even if he have an indicator before him which can be consulted at will. It is in the study of conditions, however, and the determination of those most suitable for the particular

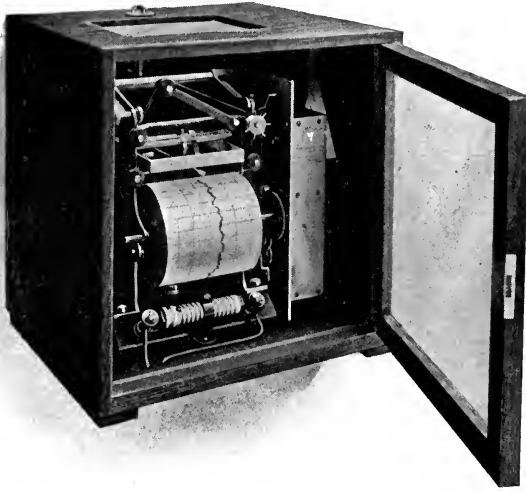

FIG. 145. Thread recorder in its case.

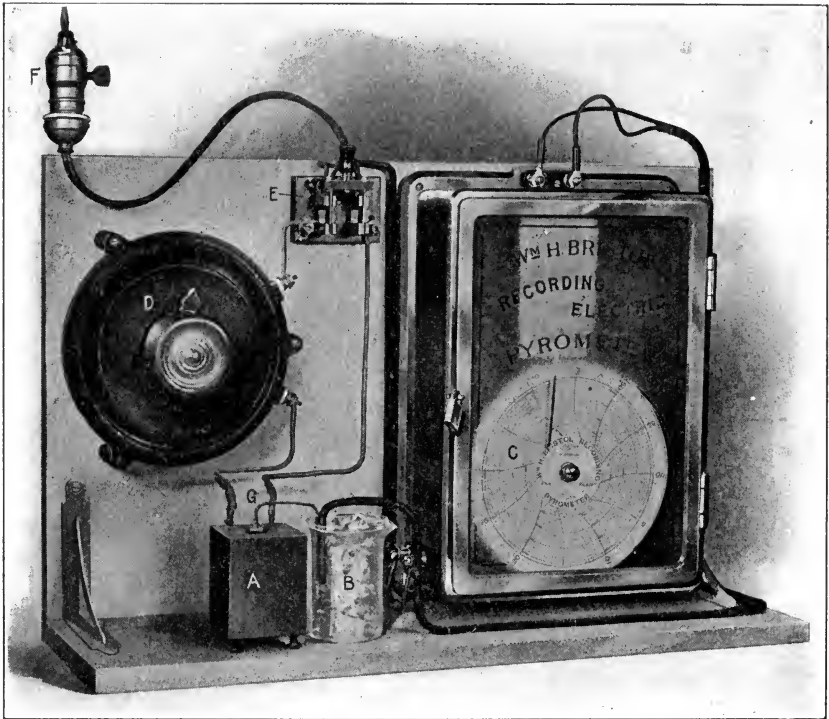

FIG. 146. Bristol laboratory electric furnace with recording electric pyrometer. A, furnace; B, ice jar for cold end; C, recorder chart; D, rhesostat; E, switch and fuses; F, socket.

work in hand — a study which should precede, and upon which the working out of each separate problem in high-speed tool-making should be contingent — that the recorder is most useful and necessary. Take the matter of ascertaining the critical point of a given steel, which should by all means (if not already certainly known) be done before undertaking to make tools from it. The curve can, of course, be plotted from frequent readings of the indicator; but it is much more conveniently and accurately made by an automatic recorder, which is dependent upon no personal equation of the observer. The record so made (there should naturally be more than one, to insure precision) then serves as a basis for subsequent heat treatments. The form of the record is not very material, though one with rectangular co-ordinates (Fig. 145) is more conveniently read than one with curved co-ordinates (Fig. 146). The latter form usually is simpler in its mechanism.

**Ascertaining Critical Points.**—The critical points of a steel can be easily ascertained by heating it in an ordinary furnace suitable for hardening, though it is frequently more convenient to do this in the office or laboratory with a small electric or gas furnace. The former, all things considered, is the cleanest and most convenient. It can be connected to an ordinary lamp socket at the operator's desk, if desired. The pyrometer "poker" for use in determining the recalcrescent and decalcrescent (critical) points, whatever the furnace used, is preferably of a special form, which may be inserted into a hole drilled into the center of the specimen piece of steel and firmly held there, or flattened so as to be clamped tightly between two pieces of the steel, these being held together by dogs or screws, preferably the latter. A recorder is not only more convenient in connection with this apparatus, but, as already pointed out above, is almost necessary in making a permanent preliminary record for future reference.

## CHAPTER XIII.

### SOME MISCELLANEOUS OBSERVATIONS ON THE MAKING OF HIGH SPEED STEEL TOOLS.

**Industry and the Scientific Method.**—The collection and orderly preservation of data as a basis for subsequent rational deduction and intelligent procedure has long been considered essential to scientific method; and now it is coming to be pretty generally understood that the scientific

TOOL RECORD.			
Tool name _____	Size _____	No. _____	Lot No. _____
For piece No. _____	Operation No. _____	Dept. _____	
<hr/>			
Steel _____	Analysis _____		
Critical point _____	Determined _____		
<hr/>			
Forging Temp. _____	Forge No. _____	Smith _____	
Hardening Temp. _____	Furnace No. _____	Hardened by _____	
Tempering Temp. _____	Furnace No. _____	Tempered by _____	
Ground before hardening _____	Finish grinding by _____		
Date Finished _____	Checked by _____		
<hr/>			
Memoranda: _____	_____		
_____	_____		
_____	_____		
_____	_____		
(Signed) _____			

Fig. 147. Form for preserving data requisite in the duplication of tools.

method is also the successful business method, whether the end sought be the perfection of technical processes or the organization of a business system. The preservation of appropriate data as a guide to the production of superior high speed steel tools by the simplest efficient methods, therefore, should need no arguing. The sneer of the small man in a small place, at "red tape" and "overrefinement," is not nearly so much

heard as formerly; and properly so, especially in connection with the manipulation of the new steels. The question is not as to the keeping of data, but as to the kind to be kept.

**Kind of Data Needed.**—Within moderately well-established limits the precise treatment best calculated to develop the highest efficiency in a tool intended for a special purpose is found usually by the “cut and try” method. It is desirable, therefore, that besides the record of the performance of the tool, there should be data showing the precise

DIRECTIONS TO TOOLMAKERS.	
1. Lot No.	_____
2. Kind of tools	_____
3. Steel	_____
4. Class of work	_____
<hr/>	
5. Hardening furnace	_____
6. Temperature	_____
7. Method of cooling	_____
8. Temperature of bath	_____
<hr/>	
9. Method of tempering	_____
10. Furnace	_____
11. Temperature	_____
<hr/>	
12. Memoranda:	_____
	_____
	_____
	_____
	_____
<hr/>	
Completed	_____
<hr/>	
(Signed)	_____

Fig 148. Card with directions, accompanying order for tools.

conditions in the treatment of the tool while in process of manufacture. These conditions are comprehended in the form shown herewith (Fig.147). Once definitely known, the conditions can then be varied from time to time, as may be indicated by the results obtained from the tool at work. Obviously when a set of conditions is found which yield just the proper excellence, it is necessary only to duplicate them. These conditions

will then be definitely indicated in the directions (Fig. 148) accompanying each subsequent lot of tools of the kind. It will be understood, of course, that there is small value in such data and directions unless the tool manufacturing plant is equipped and manned so as to take advantage of the information collected and furnished; that is, unless the plant has a variety of furnaces and other appliances suitable for obtaining accurate information as to conditions and for meeting the requirements indicated upon the direction cards.

**Hardness Test of no Value.**—Time spent in experimenting intelligently—that is, experimenting with adequate appliances, materials and data—to fit the tool most nearly to its work, to give it that treatment which will produce the highest attainable efficiency in its special work, is profitably spent. Of the elements involved in tool efficiency, hardness and temper formerly were considered the most important considerations in design, conditions of use being little regarded. The intelligent making of high-speed tools, of course, involves a consideration of all these, and of other elements, giving to hardness or temper its appropriate place. The extreme hardness of many of these tools has frequently led to the inference that a tool had been properly treated if only it came out very hard, so hard that a good file would not “touch” it. It has been shown elsewhere that hardness is no certain test at all of the efficiency of a high-speed tool; that while extreme hardness is desirable in certain classes of work (cutting very refractory stock, for instance), in others it not only is unnecessary, but perhaps even undesirable. As a matter of fact, the largest users of the best makes of high-speed steel find that for many purposes tools do the best work and give the most efficient service when soft enough not only to be “touched” by a good file, but so soft that it will “take hold.” However that may be, the file test for high-speed tools is quite valueless, even in those cases where it is desirable that the degree of hardness be determined. Such tests, to be of value, would require that the files used be absolutely uniform in temper. Even the best of files, however, vary more or less in temper and hardness; and a tool passed as hard enough when tested by one file, might easily fail to pass the test when tried by another presumably of the same temper.

There are now available several pretty accurate tests for hardness, none of which (for reasons just assigned) are of much practical value in making high-speed tools. The only real test of such a tool is the work it will do under the best practicable conditions. The best conditions of treatment once determined and made a matter of record, the same quality can be indefinitely reproduced.

**Allowance for Reduction of Size, etc.**—The necessity for using larger sizes of stock for high-speed lathe and similar tools is considered elsewhere (chapter on Design). Usually it is of no particular importance,



in tools of this type, whether the stock is exactly sized or not, so long as there is enough material to withstand the enormous strains and prevent vibration, and consequently inferior and inaccurately sized work. In other types of tools, however, as in drills and mills, it is necessary to take into consideration, in ordering stock, that an allowance must be made for the burnt skin which must be removed in making tools of this sort. While the effect on high-speed steel is apparently much less marked than in the case of carbon steels, nevertheless the long continued high heat in annealing affects the surface of bars enough to make it necessary to remove the same to a depth varying more or less according to the size of the bar. In stock above an inch in section an eighth of an inch should be added to the required size. In larger sizes of stock the proportionate allowance decreases rapidly.

**Shrinkage in Fine Tools.**—The allowance for shrinkage in finely sized tools during the hardening process, of course, is a different matter, the allowance being very minute, and generally unnecessary if the hardening be carefully done, particularly if done by the barium chloride process. Loss in size almost invariably is the result of exposure to the air while the tool is very hot. The loss due to actual shrinkage is so small, except in large tools, as to be scarcely appreciable and is usually negligible — when treated as just suggested. If the hardening is done by the customary methods a slight allowance is possibly desirable in the case of certain tools — say in the arbor holes in milling cutters, the diameter of taps, and the like. With care in hardening, even by the customary processes, the variation in a diameter of an inch, or thereabouts, will scarcely exceed 0.005 inch, and more likely will be less, though indeed it may be as great as 0.01, and even more. It depends so much upon the care exercised and the method employed. It should scarcely need adding that the holes in all mills intended for very accurate work require to be ground after the hardening, the mills having been first carefully centered in a chuck.

**Rough Surfaces—Prevention.**—It may be added also that apparent variation in the size of tools like threading-dies and taps, and other tools which cannot be ground after hardening, is frequently only the effects of the roughening of the surface during the treatment. The barium process overcomes this difficulty entirely, unless, as usually is the case, it is present before the hardening. Generally this roughness arises from the method of cutting the threads or other teeth, as the case may be. Such threads or teeth are best, and of course most quickly, cut by milling them, lubricating the cutter with thin oil. Next to this it is best to rough out the threads with a chaser, as close to size as may be, without lubricant; and then to re-cut or finish with a single-point tool held in a spring-thread holder, the threads being kept lightly lubricated with very thin oil. To compensate for the slight roughness often present

in high-speed tools of this class, it is customary to give rather more relief than in the case of those made of ordinary steel. The increased relief minimizes the lodging of particles of steel in the surface of the cutter behind the cutting edge, which, acting as cutters themselves, sometimes very appreciably increase the cut.

**Securing Smoothness in Drill Flutes.**—Extreme smoothness is a desirable quality in high-speed drills also. It seems impossible to obtain, by present methods of cutting, a smoothness of surface like that obtainable in carbon steel drills; and on this account the flutes usually are polished. If the hardening is by the barium process the polishing may be done before hardening, for that process leaves the surface absolutely unimpaired.

**Continuity of Structure Desirable.**—Though the early method of economizing in steel by using tool-holder stock rather than making the entire tool of high-speed steel, in the case of those tools whose cutting edges or points work without intermittence, as those used for turning, planing, and the like operations, is criticised elsewhere, the substance of the criticism will bear repeating here. A characteristic of the operation of high-speed tools at high speed is the rapid generation of heat at the cutting edge. In the case of milling cutters and the like tools this is of small consequence, because the cutters are intimately attached to a relatively large mass of metal which allows the heat to be conducted away very well. Furthermore, the cutters work intermittently, each for a very brief space of time, and for the remainder of the revolution are exposed to the air and cooled by it. The cutting edges are not allowed, therefore, to get exceedingly hot, as is the case with the edge of a turning tool run at the same speed. It is necessary that the body of such a turning (or similar) tool be large enough to conduct away a considerable portion of the heat generated at the cutting edge; and in order to do this effectively the tool must be continuous; that is, there must be no appreciable interval between the part of the tool which does the cutting and the body from which the heat is radiated for the most part, as there is ordinarily when a small piece of steel is held in a tool holder. There are indeed tool holders which minimize this difficulty; but even these are not satisfactory in large sizes.

**Welding High-Speed to Carbon Steel.**—From the first, methods were sought whereby high-speed steel cutting points could be intimately combined with tool bodies of ordinary and much cheaper steels. For the most part the methods tried were ineffective. Welding the two kinds of steel by the customary method has never been found practicable. The reasons are not well understood. The disinclination of the two steels to unite probably is due to a difference in their coefficients of expansion, that of high-speed steel being relatively low. There is, however, no trouble in brazing them together; and when this does not

involve placing a great strain upon the brazed joint, the method does very well. Obviously the cutters are hardened before being brazed into place.

**Brazed Cutting Edges.**—A successful example of such a combination is a lathe or a planer tool, Fig. 149, made with practically no forging and with a relatively thin plate of high-speed steel brazed to the front and top to form the cutting edge. Rose and other forms of reamers and mills have



Fig. 149. A planer roughing tool with stock made of machinery steel and cutting edge of a relatively thin strip of high-speed steel brazed to the supporting stock. In use regularly in shops of the Lodge Shipley Machine Tool Company.

been made in a similar way, the body of machinery steel being machined with recesses for high-speed blades which are brazed into place. Such tools have been in use for several years and with excellent satisfaction. The latter especially are as good as if of solid high-speed steel, except when it is essential that they be re-annealed or re-hardened — which need not usually be the case.

**Electrical and Autogenous Welding Practicable.**—Almost as soon as the new steels made their appearance the writer suggested and demonstrated the possibility and feasibility of welding electrically and autogenously a high-speed cutting point to a machinery steel tool body,

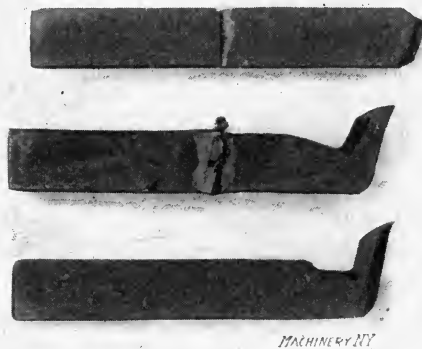

Fig. 150. Welding a high speed steel cutting end to a machinery steel stock. The parts, the welded tool with bur, and the tool with bur ground off, are shown. Courtesy of Thomson Electric Welding Company.

the latter of such proportions, of course, as to give the requisite strength to the tool. Such tools conform to the requirement of being perfectly continuous, and the weld is practically as strong as the rest of the tool. It is feasible to forge the end to any required shape, as if the entire tool

were of high-speed steel; and since in hardening only the nose is heated to the high heat anyway, the machinery or tool steel body is in nowise impaired. The high speed steel part should extend back as far as the hardening heat is likely to go.

**Method of Electrical Welding.**—The method of electrical welding, as used in this connection, is exceedingly simple. The two pieces to be welded are attached to the terminals of a circuit of suitable tension, and the edges brought together. The resistance to the passage of the current offered by the imperfect contact sets up enough heat to melt the metal and forms a perfectly homogeneous junction. The autogenous (oxygen or acetylene blowpipe) method is almost as simple. The flame is directed into the crevice where the two pieces are brought together, and melts the adjacent metal so as to form also a homogeneous joint.

**A Different Method.**—Another method (patented) recently brought forward, somewhat resembling brazing, is asserted to give a joint fully as strong as the rest of the tool. A thin film of copper is placed along the line of the joint, and the parts to be welded are surrounded by a reducing compound and then placed in a furnace raised to a temperature of about 1200 degrees C. (2200 F.). The copper flows freely into the interstices and is said to produce actual cohesion between the adjacent molecules, making a perfect joint, so strong that a fracture will follow a new break rather than pass through the joint.

**Availability of Welded Tools.**—These methods are available for all classes of tools conveniently made in part of high-speed and in part of machinery steel or other materials. Reamer and mill blades, die faces, shear blades, back knives, and the like, all are readily welded to supporting forms or backs, and make tools quite as efficient as if of solid high-speed steel — and generally much more so than if the cutters or faces were attached by screws, bolts, rivets or similar methods. Long shank and extension drills, reamers, and the like, can readily have the cutting parts of high-speed steel and the shanks of cheaper steel. The processes, especially the electrical, are available also for the repair of broken

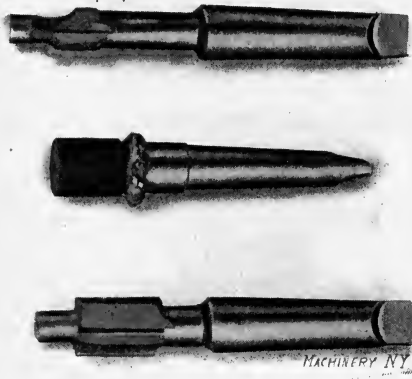

FIG. 151. A boring tool repaired by electric welding process. Courtesy of Thomson Electric Welding Co.

tools, many of which can thus be saved for further use. The repairing may involve the welding of the broken parts, or the replacing of one of them by a new, as may be most expedient.

**Cutting Bar Stock, Sawing, etc.** — Only an expert can nick and break high-speed steel from the bar without damage to the structure adjacent to the fracture — and even an expert cannot be sure of doing so. The only safe way, where the end is to be used for working purposes, is to cut the bar. The circular saw is most frequently used, though a band saw is preferred for cutting bundles of small stock. Small bars can readily be cut in bundles — if held very rigidly. The saws obviously should themselves be of high-speed steel. Complaints have been made that it is impossible to saw these steels. The complaints probably originated in the use of improperly hardened saws; for there is no difficulty whatever in cutting them with suitable saws. A singular but most effective method has been lately employed to some extent. It consists in the use of a highly speeded disc of tough steel. When an unused disc is first forced against the high-speed steel, the disc does not take hold well; but after being run in contact with the high-speed steel for a time, it cuts perfectly and rapidly, leaving a clean, burless kerf. The disc may be of any steel tough enough to withstand the tremendous centrifugal and other stresses set up by the pressure and the terrific speed required. Just why such a disc cuts is not sufficiently explained. The periphery is usually found studded with particles of the steel being cut, and the “sawdust” appears to be the result of true cutting. The intense heat generated, the display of fiery sparks, the bright corona, the roaring attending the disc’s eating its way through the bar — all these together are likely to cause some alarm at first.

**Detecting Fine Cracks.**—Fine cracks in tools are difficult to discover. Even the microscope often fails to disclose them. Generally they can be detected by the very simple expedient of moistening the suspected surface with petroleum, rubbing clean, and then wiping off with chalk. Some petroleum enters the cracks and afterwards sweats out, moistening the overlying chalk. The nature and extent of the cracks are thus rendered visible. This frequently is of great importance in testing lots of high speed steel tools.

**Re-making Worn Tools.**—Tools which have worn down so as to be useless can usually, when made of solid high-speed steel, be forged or machined down and worked up into tools of smaller size, if ordinary care be exercised. It is necessary always to re-anneal prior to attempting to machine such old tools; and it is desirable also to do it in case of forging them to smaller shapes. In passing, it might be mentioned also that re-annealing is desirable after machining and before hardening all sorts of intricately shaped tools, in order to relieve any possible machine-caused strains.

In re-forging high-speed tools, whether for reduction in size or merely in re-fettling, it is desirable that they be heated up rather slowly at first. They should not be thrust cold into a very hot fire.

## CHAPTER XIV.

### RANGE OF UTILITY OF HIGH-SPEED STEEL.

**Place of High-Speed Steel in Engineering.**—When high-speed steels first came upon the market the reports of their marvelous powers were received with incredulous astonishment. To cut steel at the rate of a hundred, two hundred, and even four hundred or more feet a minute, almost as if it were cheese, seemed quite beyond the range of probabilities, not to say possibilities. Their actual performances, however, left no room for doubt that they would play an important part in the machine shop within the following few years, as indeed has now come to be the case to a much larger extent even than was at first anticipated.

**Extended Utility of the New Steels.**—The first high-speed steels very naturally had defects which limited their usefulness as well as their use. It was seen very quickly that while it was possible to remove surprising quantities of metal, the tools could not be used for fine work, it being impossible to produce keen-cutting edges suited to finishing work on metal, or to wood-working and similar uses. From the fact that many who are familiar with the new steels seem even yet to have the opinion that they can be used advantageously only for heavy metal cutting, it would appear that this characteristic still marks some of the steels on the market. However that may be, there has been such improvement of the quality, that is to say, of the structure, of high-speed steels through changes in their composition and the perfection and refinement of the methods of hardening and tempering, that there is scarcely a use to which a carbon steel tool can be put where one of high-speed steel will not only do more, but in most cases better work—provided, of course, the machine in which the tool is used is as well adapted. This may seem a trifle strong. There are manufacturers of high-speed steel, however, a number of them indeed, who unqualifiedly guarantee to make cutting tools to replace any carbon tool whatever with a high-speed tool, at a distinct saving to the user. However much their confidence may be justified, it has been demonstrated beyond question that high speed steel tools, despite the high cost of the material, compared with carbon steel, are more economical in four out of five jobs, generally speaking, in the metal-working industries, and in even a larger proportion of cases in certain other industries where cutting tools are required.

**Especial Field for High-Speed Steels.**—Obviously alloy steel is peculiarly adapted to all operations where it is necessary to remove large quantities of superfluous metal, and to machine material so hard as to be quite beyond the power of ordinary tools, though it does not necessarily follow



FIG. 152. The new steels are especially effective in heavy cutting. Chips even larger than these are by no means rare in certain shops.

that in this sort of jobs it operates at its greatest efficiency, as may be seen hereafter. In some shops of course this sort of work is comparatively large; but in the average shop such operations form but a small proportion of the work. The real test of the utility of the new tools is in their economical applicability to the multitude of ordinary jobs, for the doing of which ordinary tools have heretofore served very well.

**Limitations.**—It must be quite evident that what has been said refers mainly to tools used for cutting. There are, however, a good many uses, as will be indicated hereafter, where high-speed steel is highly efficient in tools of a very different character. For the most part, however, it is applicable to cutting tools. It would be absurd, for exam-

ple, to make a sledge hammer of high-speed steel, at present cost, if intended for ordinary use.

**Conditions of Work Affect Efficiency.**—It is important to bear in mind, when considering the relative efficiency of high-speed and carbon steel tools, the conditions under which they are worked. The latter have this advantage, under ordinary circumstances, of being used in machines designed with reference to their particular limitations and capabilities. The former, however, unless used in machines of the newer types, designed and built especially to withstand the tremendous strains and to give the extraordinary speeds and feeds applicable in the case of high-speed tools, cannot in the nature of the case work at their highest efficiency. The high-speed tool must be used in a high-speed machine, in order to develop its powers and show its relative value as a tool. Under such proper conditions, there can be no question whatever of the superiority of high-speed tools over ordinary ones, in all cutting operations at least.

**Pre-eminence in Heavy Cutting.**—In the case of heavy cutting, the removal of large quantities of metal, of course the new tools are pre-eminent. But the question may well be asked, why should it be necessary to remove large quantities of metal, except possibly in a few cases where it is impossible to forge or cast nearly to the required shape? Well, it is cheaper to do it, in very many if not in all cases. Take, as an extreme example, the making of a very large crank shaft. It is scarcely within reason, under present conditions in shops capable of handling work of such magnitude as a hundred or a hundred and fifty ton forging, to work such a piece down under the press or hammer to the required dimensions and form. The forging concludes with a rough approximation of the finished form and dimensions, and the machine tool does the rest. Even the tong-hold or porter bar is drilled off.

For a long time it has been understood in well-regulated shops that when the amount of metal removed is not great, compared with the size of the piece, it is much cheaper to manufacture from bar stock pieces duplicated in large numbers, rather than first to forge them. Now that high-speed steel is available, it is demonstrated that the same thing is true where it would be necessary to remove a great deal of metal. A specimen job is shown in the annexed figure (154). The hatched portion shows the metal cut away from the bar stock. It is seen to be considerably greater than that remaining in the finished piece — two and a half times as great, indeed; for the weight of the part before finishing is a little greater than 117 pounds, while after finishing it is but 34½ pounds, the chips removed weighing a trifle over 82½ pounds. Even with this great waste of material the cost of producing this particular piece has been considerably reduced by omitting the forging, and rapidly reducing from the bar with a powerful lathe. The milling operation at the end is of course the same as it was when made in the old way.



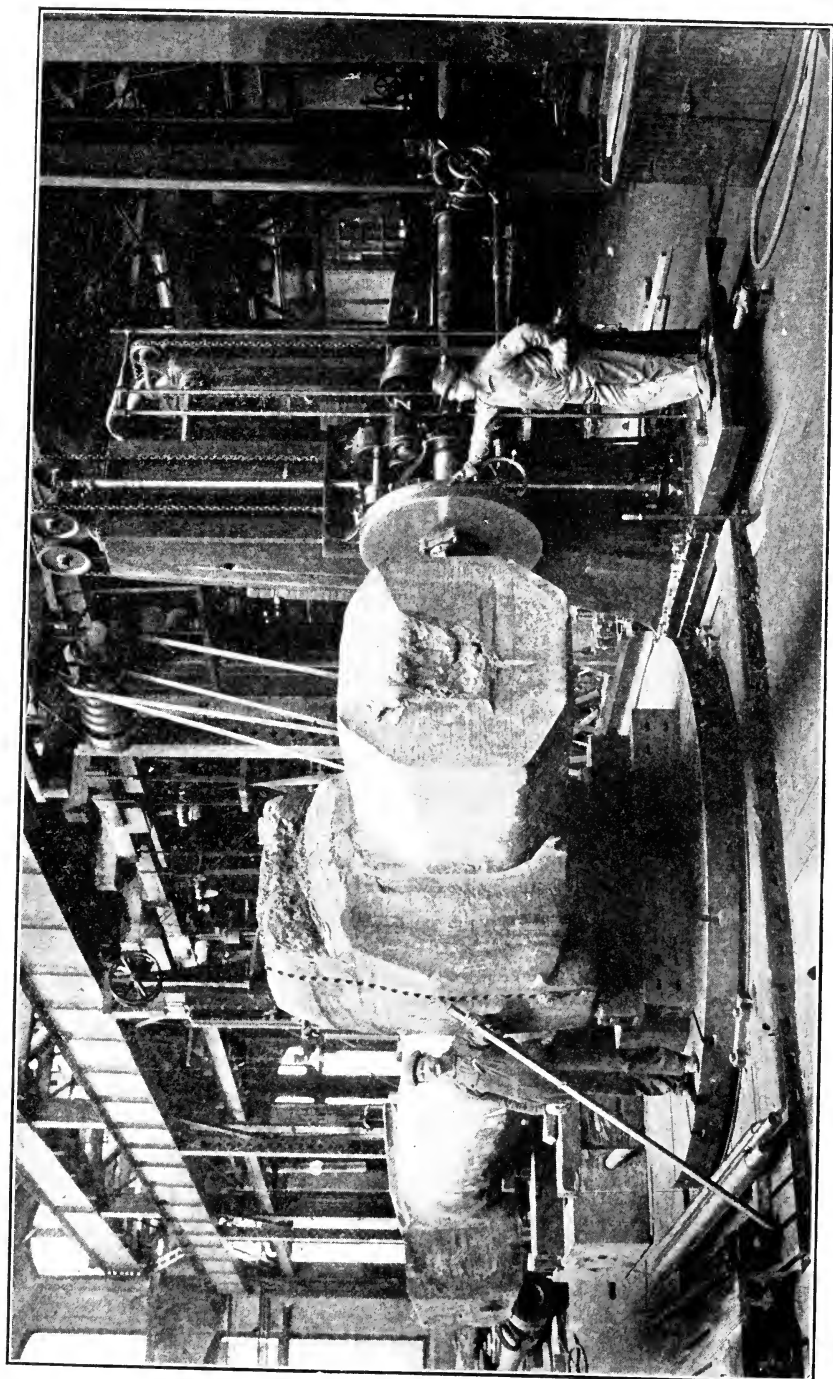

FIG. 153. Heavy forging is costly, and it is often cheaper, as in this case, to forge roughly and remove a good deal of metal by heavy cutting than to forge closely to size and finish with light cuts. The illustration shows the operation of drilling off the tong-hold or porter bar from a 280,000-pound crank shaft forging.

**Forging vs. Heavy Cutting.**—In jobs such as constitute the ordinary run of work in factories, the design of parts naturally avoids, as far as possible, such forms as require a great deal of forging or cutting; and

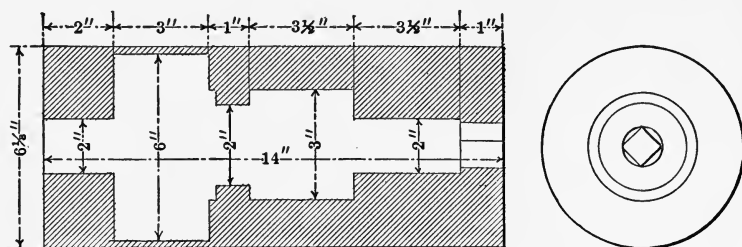

FIG. 154. Typical piece of work especially adapted to rapid reduction by use of multiple tools, rather than forging approximately to size and then finishing on lathe.

cases like that just taken are comparatively rare. There is on this account usually a good margin between the cost of forging and finishing, and finishing directly from stock, in much of the work going through any particular shop.

**The Situation as it affects Castings.**—In the case of iron and steel castings it is about as easy and cheap to mold close to the required size as not to do so; and ordinarily there is little, if anything, to be gained by heavy cutting, except in finishing the tops of large castings where defects not infrequently are of such a nature as to require the removal of considerable metal. In the case of small castings, or those of unusual form, which are peculiarly susceptible to warping, it is often desirable to mold large enough to allow for all possible deformation, and then to remove the excess of metal by machining. So also the drilling of holes, even large ones, often is more economical than coring and reaming them.

The utility of high-speed tools on cast iron has been questioned, it having been widely asserted that the new steels would not work any better than carbon tools — if as well. Whatever foundation there may have been in past experiences to warrant such conclusions, there is no longer any ground for doubting the utility of high-speed steel for cutting cast or malleable iron. The former has been turned at a speed in excess of 200 feet per minute, and regularly for all-day runs at 130 to 140 feet. It is no extraordinary performance to take a  $3\frac{3}{4} \times 3\frac{3}{4}$  roughing cut on gray iron at 60 feet per minute, and a finishing cut  $3\frac{1}{2} \times 1\frac{5}{8}$  at 100 feet per minute; though possibly this is not yet a regular thing in shops. High-speed steels of to-day cut cast iron as freely and smoothly as they do steel, though indeed the same speeds are not attainable.

**Basis of Tool Cost.**—Even if there be no occasion for heavy cutting power, or for increased speed in light cutting or finishing jobs, there is a positive advantage in the use of high-speed tools for this purpose in

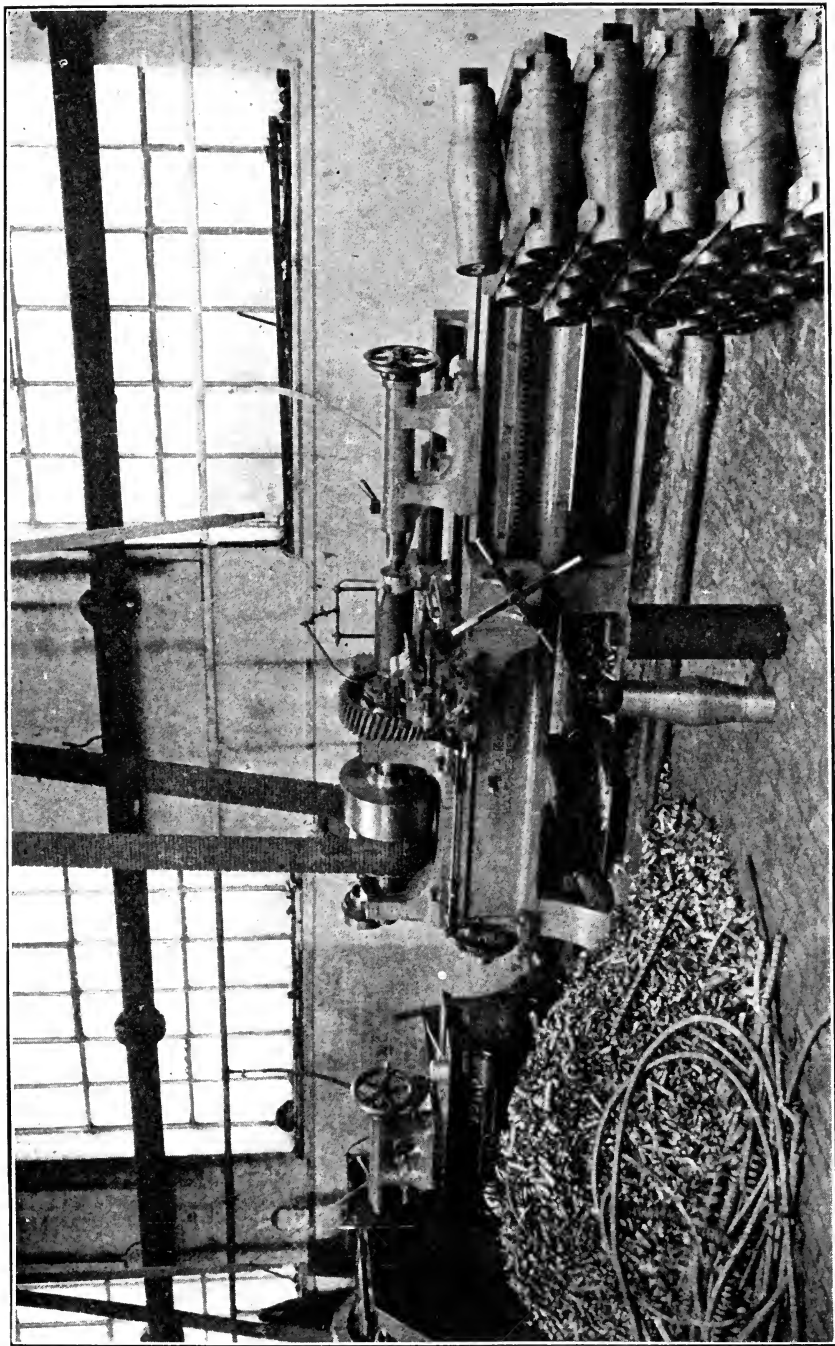

FIG. 155. Turning armor plate bolts from bar stock without forging, at a great saving. Speed, 160 feet per minute; feed,  $\frac{3}{32}$  inch; depth of cut, maximum,  $\frac{3}{8}$  inch. Metal removed in a 10-hour day, product of 40 bolts, 2480 pounds. Openshaw Works of Sir W. G. Armstrong, Whitworth & Co., Ltd.

that the cost of tool and tool maintenance is materially reduced. The first cost of a tool is usually held to be a matter of high importance; whereas it is, except only in the case of special tools when but a few pieces are to be produced, only one of several things to be considered, and not necessarily the most important of them. The only rational basis for computing the cost of a tool is the cost per piece of work satisfactorily finished. Obviously, then, the first cost may even become negligible. A much more important consideration than first cost is maintenance cost, which of course depends in large part upon the endurance of the tool, which is to say its capacity for continuously doing work accurate within the required limits. The principal consideration affecting tool cost, then, is maintenance, first cost being quite secondary.

**Maintenance Cost.**—To maintenance is properly chargeable the time required for removing the tool from the machine, putting it into condition suitable for proper work, grinding or dressing, the time lost by reason of the machine being idle, and again setting up in the machine. Evidently the longer a tool continues satisfactorily at work, the lower the maintenance cost, not only in the absolute, but relatively to the pieces finished; and consequently the greater the efficiency of the tool. Considered in this way, there will be found few cutting jobs in the ordinary metal-working shop in which high-speed tools cannot show a distinct advantage. Let us see how this works out in specific instances.

**A Specific Case.**—The following data could be duplicated many times in their essential features, in almost any shop, and are therefore typical:

Tool	Pes. per Grinding, etc.	Time for Grinding, etc.	Total Pes. Finished	First Cost of Tool	Cost of Time, per Hour
Carbon	50	5 min.	1,000	\$0.25	\$0.20
High-Speed	300	5 min.	10,000	.75	.20

From these data the following comparisons are drawn per 100 pieces finished:

Tool	First Cost	Cost of Maintenance	Total Cost	Saving, H.-S. over Carbon
Carbon	\$0.025	\$0.033	\$0.058	
High-Speed	.0075	.0055	.013	78%

Putting the result in a different form, the first cost and maintenance of a high-speed tool on this particular (but typical) job is but little more than one-fifth that of a carbon steel tool — and this without any change whatever in speed or feed, the whole gain being in the greater endurance of the tool. With an increased speed or feed, or both, of course the efficiency would have been still greater.

**Growing Use of Chilled Castings.**—There is a growing disposition to make use of chilled rather than sand-molded castings for a variety of purposes. The difficulty of machining such castings has heretofore prevented the extension of their use except in rolls and wheels, and a

few other parts where their use could not well be avoided. Chilled rolls have indeed been turned with the very best of tools and at an extremely slow rate; but further than this little has been possible. With high-speed tools of proper form it is comparatively easy to rough down rolls and similar parts to cylindrical, and even to circular and spiral-grooved forms. For reasons not well understood, high-speed steel is apparently not so well suited to smooth finishing chilled surfaces, hadfield (manganese) tools being customarily used for scraping to secure the finish surface, unless this be done by grinding. The ordinary forms of tools are quite inadequate for the turning of chilled pieces, and it is necessary to use a special form of cutter.

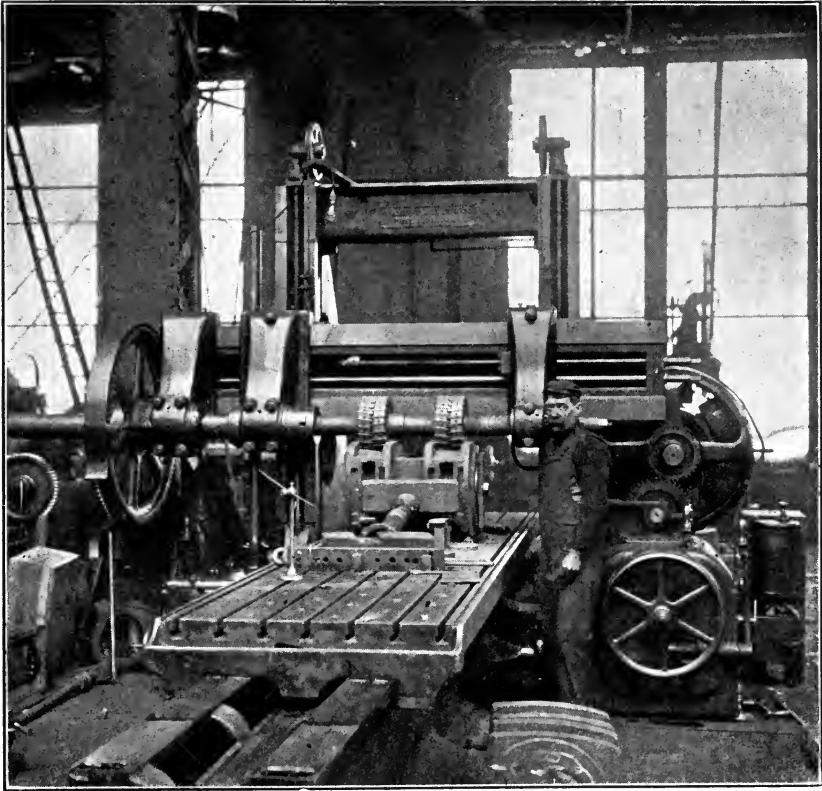

FIG. 156. The new tools have given a strong impetus to the use of the milling machine in places where previously the planer or shaper was considered necessary.

**In Reciprocating Machines.**—The inherent weakness of reciprocating machine tools, the stopping at the end of each stroke and the return for another cut, for some time tended to prevent the use of high-speed tools in connection with them. There have been developments, however, which make their use in machines of this class almost if not quite as

desirable as in the case of rotating tools or work. Even if there were no advantage gained in speed or cut, the same reasons which make high-speed lathe tools desirable, even where increased speed is not desirable or attainable for any reason, apply to planer, shaper and slotter tools also, though possibly to a somewhat less extent. The time gained in grinding is somewhat less, though the real tool cost, measured as already described, is relatively the same.

**Speed Gains in New Types.**—As a matter of fact, however, there is, in the newer machine tools of these types, a very considerable gain in speed, to say nothing of the possibility of increased cutting power. These machine tools, mostly of the recent rapid-stroke and quick-return design, require high-speed tools in order to work at their highest efficiency. A speed of 80 feet per minute has been attained effectively, while speeds of 40 to 60 feet per minute on steel are no longer considered remarkable. It might be expected that the jar attendant upon the tool beginning a new cut after each return would very largely increase the wear of the machine. This might be true if the latter were lightly built; but in the case of properly designed and constructed machines the effect is unimportant. It is to be remembered in this connection that the power absorbed in high-speed cutting is by no means proportional to the increased amount of work done. There is more likelihood that the tool will snap off with the shock of the impact, though this cannot happen if it be of suitable proportions.

**An Example of Rapid Planing.**—It is the regular thing in one shop to plane certain tough steel forgings under unusually difficult conditions at the rate of 40 feet per minute, cut  $\frac{1}{4} \times \frac{1}{2}$  inch, and to rough-plane cast-iron plates  $12 \times 23$  inches in six minutes. The finish cut takes half as long. All this on a 36-inch planer. A 24-inch machine of the same design has been run at a speed which reduced the cost of the job on which it is regularly used from 30 to 8 cents per piece, at the same time increasing the former output of from 9 to 12 pieces to from 40 to 55 pieces. Such a quadrupled efficiency of course cannot be expected as a regular thing.

**The Case of Milling Cutters.**—The evident tendency of the milling machine and rotary planer to supplant reciprocating machines has been accentuated by the new steels, whose efficiency is not subject to the same limitations in the form of a rotating tool as in the reciprocating form. All that has been said of other forms of high-speed tools with respect to their superior efficiency, holds true of milling and other rotary cutters, possibly to even a still greater extent. As with other tools, the lasting quality, the decreased amount of sharpening required, is an important item — more important even than in the case of lathe and similar tools, because of the higher cost of sharpening. The important gain, however, is usually in the greatly increased feed allowable with

high-speed cutters. An increase in speed also is permissible; and while advantage is often taken of this, the best practice in milling operations seems to be to increase feed rather than cutting speed. This on all classes of iron and steel. For this reason it is necessary, in designing these tools, to allow increased clearance to the cutting teeth and to

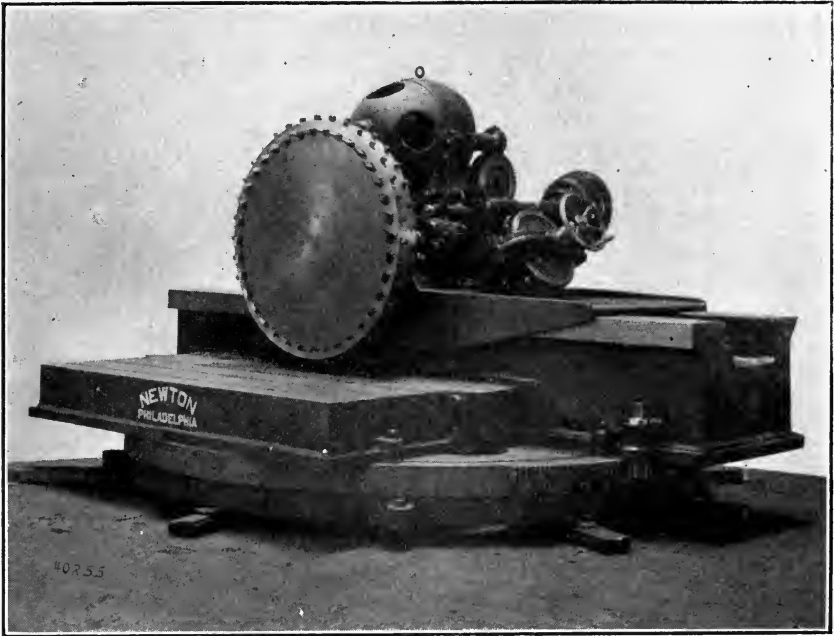

FIG. 157. Rotary planer, which is taking the place of the reciprocating machine in many kinds of work. The gain from the use of high-speed cutters is much more pronounced than in the reciprocating type, whose speed is necessarily limited.

reduce their number below that customary in carbon steel cutters of similar size. The design of these and other tools is considered elsewhere; so that it remains to point out here merely that usually, and especially in the case of those mills with narrow faces, inserted cutters allow the manufacture of a comparatively inexpensive tool in all diameters over say 4 inches. The body, once made, serves for an indefinite number of cutter sets. In smaller sizes than that mentioned it is usually desirable that the cutters be solid.

**Milling Cutter Efficiency.**—A single typical case will indicate the efficiency of high-speed milling cutters compared with those of carbon steel. On cast iron a  $3\frac{1}{2}$  inch cutter, 18 spiral teeth, cuts at a surface speed of 82 feet per minute with a table travel of 27 inches per minute, and mills 6800 linear inches at a grinding. The best results previously obtainable under similar conditions were 1300 inches to a grinding, at

a table feed of only 15 inches per minute. The carbon tool required grinding once a day, whereas the high-speed cutter runs five times as long, finishing about 1360 pieces to the 270 pieces formerly finished per grinding. It was possible to reduce the labor cost from \$1.40 to \$1.10 per hundred pieces. Besides, there was the saving in the cost of grinding amounting to \$0.11 per hundred pieces, making the entire saving \$0.41 per hundred pieces, or enough to pay for the first cost of the new tool in a week's time. In addition to this, the tool itself has an almost indefinite life, outlasting from five to twenty carbon steel tools; so that considered merely with reference to the first cost and total amount of work done, the high-speed cutter is only one-fifth to one-twentieth as expensive as the other.

**Gear Cutters and Like Tools.**—Accuracy of form and long life are especially desirable, and indeed essential, in involute or gear cutters and other formed cutters. The advantage of high-speed steel for tools of these types is so evident as scarcely to need mentioning.

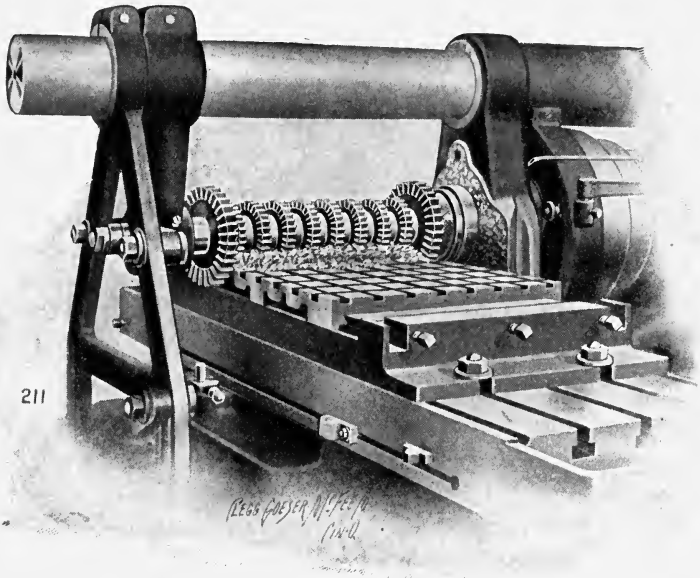

FIG. 158. Typical job of gang milling where high-speed steel tools pay. The finish on this job (cutters 4" and 8" diameter, 66 r.p.m., table traverse about 1 $\frac{3}{4}$ " per minute) is within the accuracy limit of 0.001", and no hand finishing is necessary in fitting pieces together. Courtesy Cincinnati Milling Machine Company.

**Milling Refractory Materials.**—The efficiency of high-speed milling cutters when working on refractory material has been repeatedly questioned. It is safe to say that any such question must be due to unfortunate and unnecessary experiences. Such milling cutters are successfully working on material as refractory as nickel-chrome steel armor plate, and that at a rate as high as 75 feet (peripheral) per minute. Working



on automobile parts even more refractory, high-speed cutters are found to last three to five times as long as carbon steel cutters on the same work, and do it equally well, while the feed is increased a third or more. There is no difficulty whatever in the tools standing up under the work. It is merely a matter of correct design and proper hardening to meet the requirements of the case.

**As to Drills.**—Next to lathe tools it is in drills that high-speed steel has most fully justified itself. In the up-to-date shop, drilling operations have been as much changed as have the turning operations. Speeds, and more especially feeds, have been increased, heavier machines are required, and multiple work changed from punching to drilling where that has been possible. In putting holes through plates, especially plates where the distressing of the material involved in a punching operation is sought to be avoided, the drill is now taking the place of the punch. Such plates can be stacked and the holes drilled as quickly as they can be punched — and in some cases even more economically. The result is a better hole, if nothing else be gained. In agricultural and other machine castings, where it has been customary to core holes and then ream them out, it is now often less expensive to omit the cores and drill the holes from the solid. The result, generally speaking, is a more accurate hole, even when there is no direct economy in labor cost.

**Efficiency of Small Drills.**—It may be questioned if there be any considerable economy in the use of very small drills, say under  $\frac{1}{4}$  inch. There is not enough metal in sizes smaller than this to withstand the rough usage which may freely be given larger drills; and with speeds and feeds much increased there is likely to be considerable breakage. Nevertheless there have been obtained some striking results with these small drills, and they are made for sale down to  $\frac{1}{8}$  inch and less. A  $\frac{1}{4}$  inch drill has been run continuously in mild steel at the rate of about 1100 revolutions per minute with a feed of .008 inch per revolution, without breaking down, and in grey iron somewhat faster. The rate agreed upon by common consent for carbon steel drills under similar conditions is about 220 revolutions per minute with a feed of about .005 per revolution. Stated in terms of peripheral speed the ratio is 826 to 176, or about 4.5 to 1. The same ratio can be maintained easily throughout the larger sizes also; and when it is remembered that the allowable feed is practically doubled, it is seen that the amount of metal removed in a given time is in the ratio of nearly 10 to 1. This looks big, very big. The actual economy, however, is not necessarily in proportion to the rate with which metal is removed, for the labor cost, as indicated elsewhere, is dependent upon a number of other factors also — the time lost in handling the pieces and in keeping the tool and machines in a state of efficiency, chiefly. In operations involving the boring of many shallow

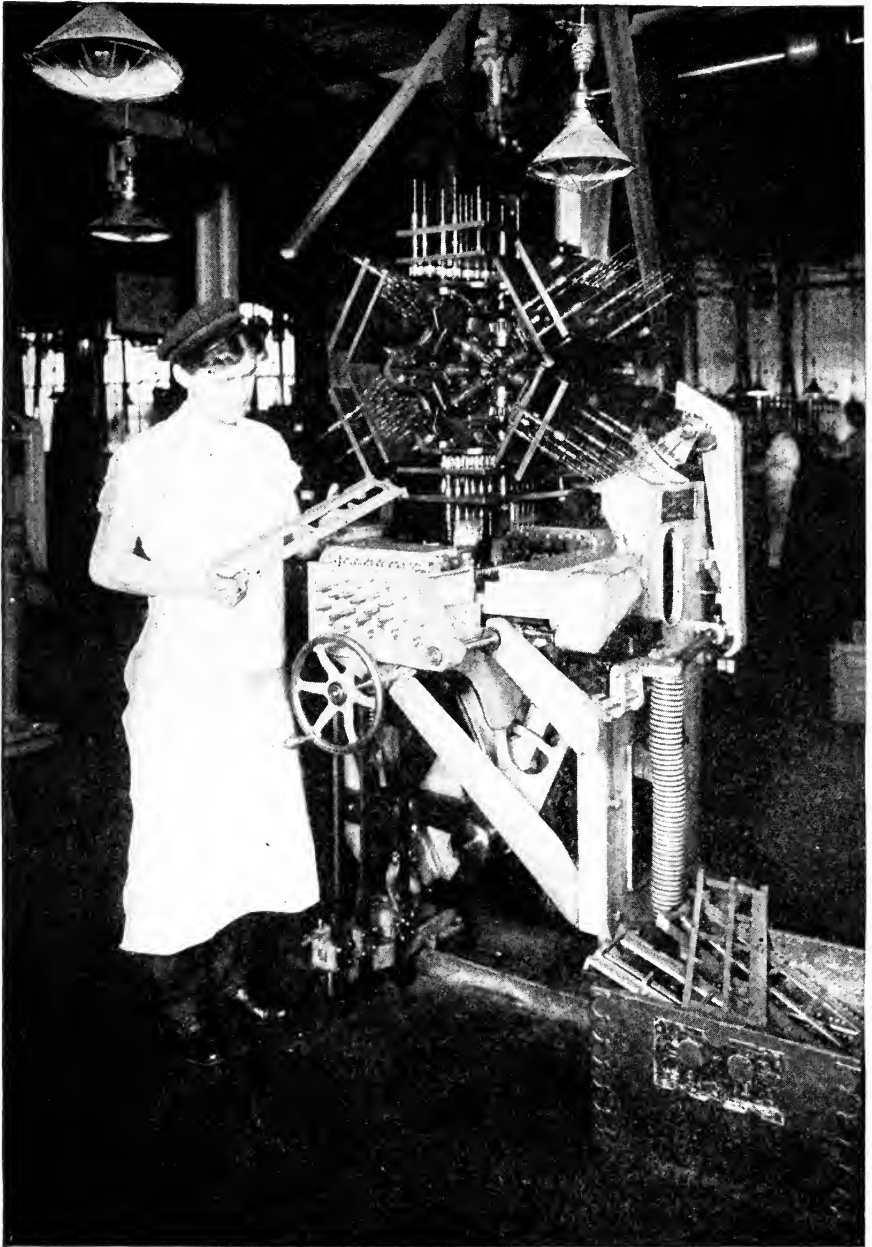

FIG. 159. In multiple drilling, like that here illustrated, the breakage or dulling of one drill means the stoppage of the work of a large number of others. The need for long life per grinding and for freedom from breakage is obvious.

holes and many changes of pieces, therefore,— that is, where the actual working time of the drill is short, compared with the whole time devoted to the piece,— the chief gain is in the longer life of the tool and the time saved in keeping it sharp.

**Cause of Excessive Breakage of Drills.**—The excessive breakage of high-speed drills sometimes occurring in working on structural forms, boiler plates, and similar high-carbon plate work, is not at all necessary. It occurs most frequently because the drills used are not adapted to the work in hand. Drills for this purpose should have a very tough temper and smooth finish, and usually are better if twisted from rolled stock rather than milled from the round.

Another cause for such breakage is the insecure holding of the several parts or plates when holes are being drilled through several members at the same setting.

**Increasing Use of Flat Drills.**— In passing it may be of interest to mention that in many kinds of work flat drills are just as efficient as the twist variety — in grey iron they are found frequently to be slightly more economical. In steel forgings the twist drills are considerably the more efficient, however, as may be seen from the accompanying figure (160). Straight-grooved drills made from round stock are also quite efficient, though not quite so cheap to manufacture as the flat style.

Of course the efficient use of drills of these forms involves accurate and correct grinding, just as in the case of twist drills.

**The Case of Rose Reamers.**—Multiple-lipped drills, rose reamers, and similar boring tools are in the same category with drills in respect to the economies to be effected and the manner of effecting them. One consideration, however, differentiates them to some extent. The latter types of tools, employed mainly in enlarging or truing holes already existing, take a relatively thin skin of metal only (usually more or less chilled and sand-covered), instead of a chip corresponding nearly to the semi-diameter of the tool, the metal all being removed by the peripheral part of the cutting edge only. The tendency, therefore, is to wear the outer angle of the tool and to reduce the size. This tendency is progressively intensified when once the wear has begun, and necessitates

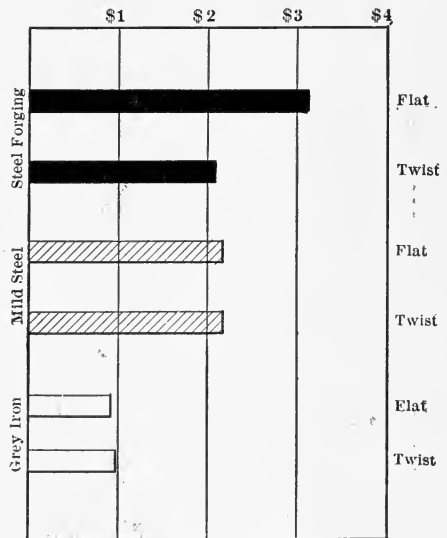

FIG. 160. Drilling. Total cost per 100 lbs. of metal removed per hour.

careful watching in order that the grinding may be frequent enough to insure not only accuracy, but efficiency. The advantages of a tool that will hold an edge for a long time under such conditions is evident. The first cost, as in the case of milling cutters, need not necessarily, in the larger sizes, greatly exceed that of less efficient tools, since inserted

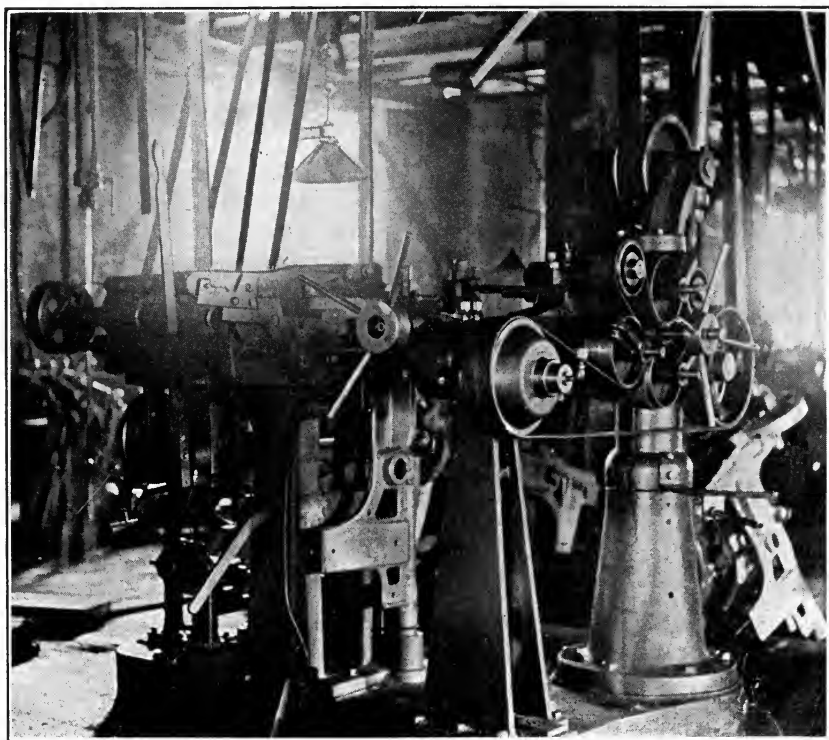

FIG. 161. An unusual special machine for drilling a large number of holes simultaneously in pieces of a single kind. Machines of such highly specialized type are peculiarly adapted to high-speed tools.

blades can be utilized almost, if not quite, as freely as with the milling tools. A reamer designed so as to permit the use of the body an indefinite number of times in connection with renewals of the blades, distributes the first cost in such a way that it becomes actually less, and usually much less, than that of ordinary tools.

**High-Speed Hand Tools.**—In connection with drills and reamers one is reminded of the stock joke concerning the man who bought a high-speed bit for use in ratchet drilling and who was disappointed because it did not cut any faster than those which he had been accustomed to use. The joke has now quite lost its point, for the new steels are coming into larger and constantly increasing use in hand tools. The gain of course is not in greater cutting speed, but in the longer life of the tools

and the greatly lengthened time during which they can be used without re-grinding. A flat drill, for example, has drilled, as a regular thing, some 1500 one-inch holes per grinding in the webs of 80-pound rails, as against about 50 holes drilled by a carbon steel drill — a gain in efficiency which practically eliminates the cost of grinding in this case. In other instances that could be cited the gain has been twice, and even three times, as large.

**Hand Files and Hand Reamers.**—The high-speed steel hand file also seems an anomaly. It is, however, an actuality, and seems to justify itself in that it lasts some four or five times as long on steel and iron as an ordinary one will, and after that is still suitable to use on brass and other soft metals. Such files rarely break; and this is no small additional advantage.

In hand reamers and the like tools there is an advantage greater still; for these are customarily used for accurate sizing, and their life is limited to the time during which they retain their size within the required limits of accuracy. Even when made capable of slight expansibility, the life of a carbon reamer of this class is short enough. The question may well be asked, in view of the very great superiority of the reamer made of high-speed steel, what profits it to use the former at half the cost when the life of the latter is ten to twenty times as long?

**Considerations Affecting Threading Tools.**—The same considerations which affect small drills likewise affect small threading dies, taps, and similar tools. If left hard enough for the most rapid cutting, the small cutting points or edges are too brittle to stand up to the work. Proper hardening (say by the barium process) and tempering, however, entirely obviate this difficulty if the design is at the same time slightly modified, as pointed out elsewhere. The cutting speed is of course less than would be possible if the highest heats could be used in hardening. Taps as small as  $\frac{1}{16}$  inch have been used under these conditions at an efficiency ten to fifteen times that obtainable from carbon tools. In automatic machines the time lost in replacing dulled cutters is one of the important items which can be materially reduced by the use of the new steels. The breakage of taps is even less than with the old tools, if they have been properly treated.

It does not seem necessary to consider at length other varieties of cutting tools comparable to those already mentioned, except perhaps cutting-off saws and the like. The former, in action and efficiency, are affected by about the same considerations as those previously considered.

**Sawing Operations.**—Between the hack-saw blade of old, and the best cutting-off saw made prior to the application of high-speed steel to such use, there is a difference, to be sure. But all tools of this class have been lamentably inefficient. The high-speed steel hack-saw blade,

now considerably used, of course much outlasts the ordinary sorts in both hand and power sawing. The latter mode of cutting, however, is itself very inefficient and is properly being displaced by high-speed band and circular saws. The band saw, until recently thought impracticable, if indeed not impossible, is undoubtedly the most efficient for sawing high-speed steel itself, and likewise is highly efficient for sawing all other

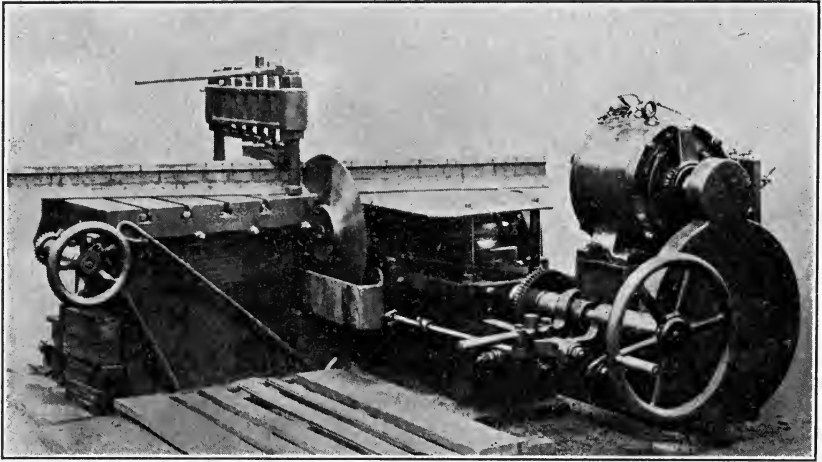

FIG. 162. High-speed cold saws are used not only for cutting structural and other forms, but for slotting operations. These saws are also suited for hot sawing.

kinds of iron and steel structures and forms where the nature of the case permits its use — as often it does not. In those cases the circular saw comes into play with a high efficiency. This of course does not cut metal as if it were wood, but certainly at a rate somewhat in keeping with present ideas of expedition.

**Inserted Tooth Saws.**—Narrow-faced milling cutters have heretofore been used, for the most part, in high-speed sawing. It is now possible, however, to obtain saw plates of a considerable diameter. Such plates, in sizes above, say nine or ten inches, have been rather difficult to make; and even now it is doubtful if it is desirable to use them, except possibly in special cases. The inserted cutter idea is peculiarly applicable to circular saws of large diameter; and such tools are now considerably used, not only for cutting off, but for slotting and similar work. A special type of machine is required for such work, especially if heavy. A number of these are now available and give promise of taking an important place in the metal-working industries. A typical case is that of a recent machine operating two saws of 73 inches diameter, cutting  $1\frac{5}{8}$  inch slots. Such an operation would be quite out of the question but for the new steels and the inserted cutter.

**In Non-Cutting Operations.**—There is a constantly increasing use of high-speed steels for purposes which do not involve cutting, in the ordinary sense, at any rate; and in which increased speed is not the end sought any more than in the case of hand tools. Among these uses are those involving the shearing of metals, including among other tools shear blades, punches and broaches, blanking dies, and cutting-off dies. The economy in all these cases obviously is entirely in the longer life and

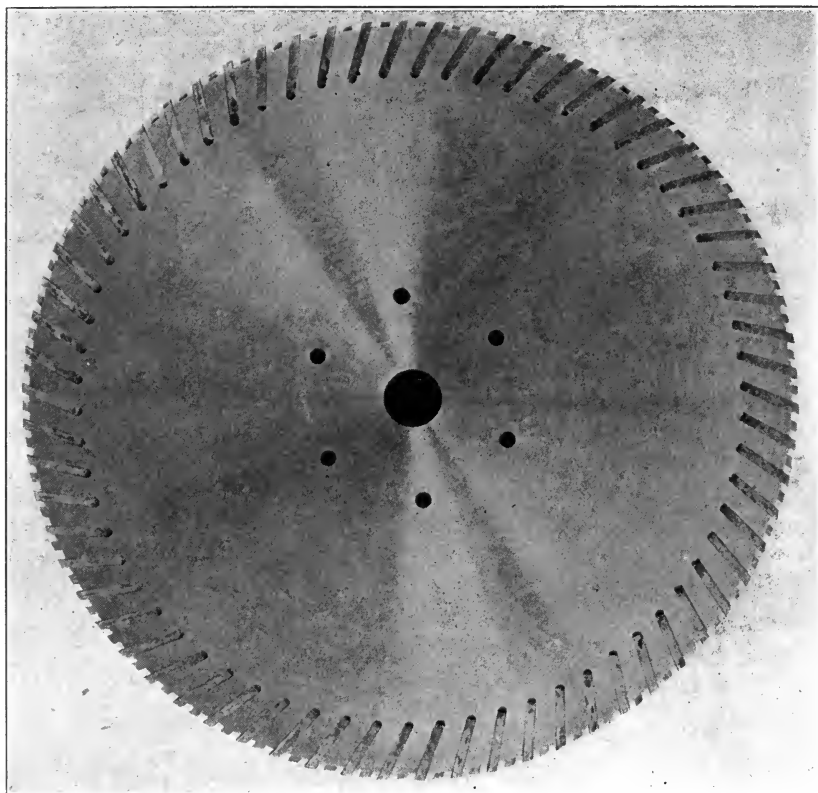

FIG. 163. Tindel inserted-tooth cold saw.

the reduced number of grindings necessary. Unless small, shear blades and cutting-off dies rarely are made of the solid high-speed steel stock. Usually the custom has been to bolt a relatively thin plate to a supporting block; or in the case of heavy work, brazing the high-speed face to the backing. The recently developed methods of electric and autogenous welding makes it possible to get practically solid tools at small expense for alloy steel.

**Efficiency in Blanking Dies.**—Blanking dies, if small, usually are of solid high-speed steel; though there is no objection to making them with a cheaper backing. Larger dies, of course, always have the face only of

high-speed steel. The cost of such a compound tool need not be greater, usually, than that of the ordinary kind; and frequently it may be less. The question in tools of this sort is that of getting and maintaining a sharp, clean shearing edge. Otherwise the work is likely to be indifferently done. Once the edge has begun to upset or wear away, the tendency is toward a progressive deterioration until it is necessary to re-face by grinding. The superiority of high-speed steel in this kind of work is sufficiently indicated by one example. In blanking sections for agricultural machine knives, 14,000 to 15,000 pieces per grinding is con-

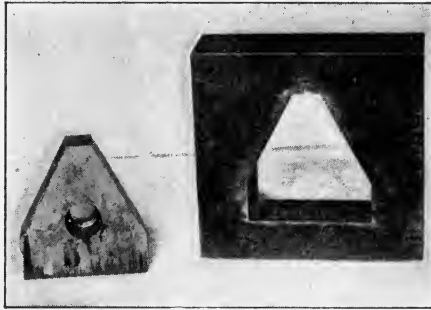

FIG. 164. High speed is especially efficient in blanking dies. A pair of dies like this has blanked a million pieces.

sidered average work for a good die of special die steel, while the total output might reach 150,000 to 160,000 pieces. A high-speed die on the same work (blanking from 11 to 16-gage polished bands of medium carbon knife steel) produces regularly 40,000 to 50,000 pieces per grinding, and the average total output is about 1,000,000 pieces — the maximum record for such a die being about 2,600,000 pieces. The saving in grinding, therefore, is two out of every three; and the life of the die averages that of some twenty of the special steel dies. A little figuring as to the cost of each kind makes a very interesting study under these conditions. Of course the relative efficiency of such dies will vary a good deal according to the material and the working conditions; but a substantial increase in efficiency in practically all cases is certain.

**In Punching Operations.**—In punching operations, properly so called, the same high efficiency may be expected — indeed considerably higher, usually. The ordinary punch generally gives out by collapsing or breaking off after the edge has become somewhat dulled. The increasing force required to drive the tool through, that is, to shear off the metal removed to form the hole, seems to increase very rapidly the molecular fatigue or intensifies already existing internal strains to such an extent that the endurance limit is soon reached. In punches made of high-speed steel the shearing edge wears much less rapidly, and, if suitably hardened and tempered, the body longer resists the strains than in the



case of ordinary tools, as is indicated by the typical performance of a  $\frac{7}{8}$  inch punch working in medium carbon channel iron  $\frac{3}{8}$  inch thick. The average life is between 50,000 and 60,000 holes, whereas that of a tool steel punch rarely reaches more than 6000 holes. This ratio is

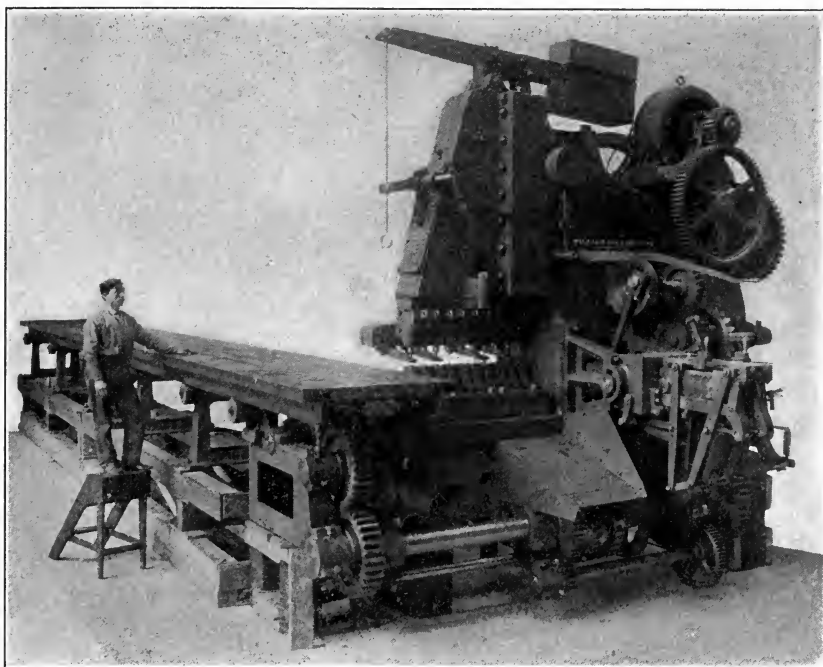

FIG. 165. Gang punch, where the breakage (oftenest because of first becoming peened over) of one punch means considerable delay.

found to be quite common. In broaching operations, such as are usual in connection with malleable castings, the efficiency is, if anything, rather greater.

**Objections to High-Speed Punches, Taps, etc.**—The objection is often made to high-speed punches, as to taps and small drills, that they are too brittle. The same answer, however, applies, namely, that proper hardening and annealing, to give requisite toughness (always assuming a properly selected brand of high-speed steel, for these differ a good deal in this respect among themselves), obviates the danger of breakage, or reduces it to a minimum. Small sizes of punches, when for use in punching thick and high-carbon steel, are indeed rather difficult to harden and temper to just the point where the combination of hardness and toughness is right for maximum performance; and unless this problem has been well worked out in connection with the particular material worked upon, the increase in efficiency will be slight, if indeed there be any at all. In hot punching the gain is considerably greater than in

cold, since the temper is not drawn by the hot material, as is likely to be the case with ordinary punches. For the same reason dies of these new steels are especially efficient in hot cutting-off and similar hot work.

**Forming Dies and the Like Tools.**—Since the advent of the readily worked low carbon sheet steels, working freely in press dies, the displacement of small castings by formed steel pieces has been going on apace, and the press-working of sheet metals has come to be an important branch of metal working. In all but the simplest of forming dies the wear on certain parts is excessive, compared with that on others; and in consequence the dies, usually expensive on account of the very narrow limits permissible in respect to their accuracy, soon become worthless because they have become worn beyond the limits allowable for good work. Even the hardest carbon steel forming dies have a comparatively short life. This is especially true of embossing dies of intricate design. Since the principal item of expense in these tools, and particularly in embossing dies, is in the highly skilled labor going into them, the first cost of the material is of little consequence. Anyway a part of the additional cost of the high-speed steel material can be saved by merely facing the dies with it, or making inlays at those places where the wear is greatest. In this case greater care in hardening is necessary.

**Place in the Forge Shop.**—In the forge shop also the new steels are coming to claim an important place. Much that has been said of forming and embossing dies applies to drop and hot-press dies also. It is cheaper, that is to say, to use the more expensive material in the first place than to pay for the more frequent renewals necessary if ordinary steel is used. Whether because of some difficulty in hardening to a sufficient depth, or because of the drawing of the temper by the hot work, or for some other reason unexplained, drop and similar dies subjected to concussion frequently sink under the severe pounding which they receive, accentuating the effects of wear. High-speed steel dies do not seem to be subject to this failing. In the heading machine, and other hot-pressing operations also, high-speed steel dies show a relatively long life. The excessive wear and the liability to drawing the temper when made of ordinary steels and thus still further reducing the effective life, suggest the advisability of discontinuing entirely the use of carbon steel for such purposes and the substitution of some form of the new alloy steel, whether properly designated high-speed or not. The possible exception is the case of those dies subjected to such tremendous pressures, as in cold-heading very tough stock, that the die blocks often split. Wherever it is a matter of resisting wear and maintaining size, the new steel clearly has shown its title to preference.

**Drawing Dies and Miscellaneous Tools.**—In no case has this been more notable than in such operations as wire drawing, and also in cold drawing. One of the chief difficulties always is the maintenance of a uniform

size in the rod or wire passing through the die. If the material is exceptionally hard and accurate sizing is essential, the difficulty is serious. An alloy steel die often outlasts thirty or more ordinary ones. A similar efficiency is frequently found in snap dies used for riveting of all sorts, especially in pneumatic rapid blow tools. Chisels used in the same kind of tools, and those used in file-cutting, also have a high efficiency, in spite of the often repeated assertion that high-speed steels are



FIG. 166. Die for drawing down lead covering over table.

not suited to tools of this sort and to any operations involving continued concussions. It is possible that their efficiency is not so marked in these cases; and undoubtedly in certain conditions there is likely to be small or no gain in their use. Nevertheless high-speed chisels and hammers are in successful and efficient service in such difficult work as riveting and trimming boiler plates, and chipping and hammering castings. Even a hand hammer of high-speed steel has been used to advantage in the latter kind of work. The efficiency depends a great deal upon the particular work required. Unquestionably the main reason why many tools for similar purposes have not been made of the new steels, to any considerable extent, has been the high cost of material. This reason no longer holds, since it is feasible to provide almost all sorts of tools with high speed steel wearing surfaces or cutting edges at small expense.

**Limitations of High-Speed Tools.**—If, then, high-speed steel has been found well suited to all these uses (as indeed it has, and to many others also), what are its limitations? Can all tools be profitably made of the new steels? By no means — yet, anyway. But in the machine and related shops, working in iron and steel, it seems probable that it might be so. It is certain that the men who have given the matter the most careful attention very generally are of opinion that there are comparatively few uses in such shops where high-speed steel is not practicable and economical, though possibly few would care to go to the extent proposed by the superintendent of motive power of one of the largest American railways, who proposed to scrap the entire outfit of old tools and replace them with suitably and economically designed high-speed tools for finishing jobs as well as for ordinary work.

**About Finishing Cuts.**—Whatever may have been the case with the early kinds, the assertions yet often heard to the effect that high-speed steel is unsuited to finishing cuts are mostly twaddle, based on insufficient experience and upon experience with improperly designed or treated tools, or tools used in machines unsuited to the work in hand. Elaborate theories have been advanced to account for the lack of finishing quality in these steels — which lack does not exist, in good grades

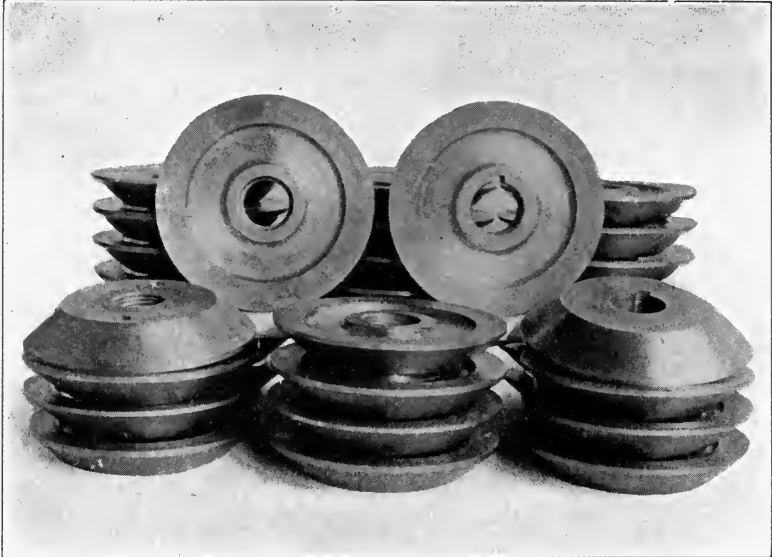

FIG. 167. Slitting knives for sheet metal cutting.

at any rate, if in any. It is no uncommon experience to take finishing cuts (one cut only) from the bar at a high speed and leave a surface in every wise satisfactory and with an accuracy within 0.002 of an inch. In some shops finishing cuts are taken at a speed as high as 200 feet per minute, the feed being rather fine; and 30 to 50 feet is common practice. The tools and the machines, however, are properly designed and adapted to each other, and the former are hardened and tempered appropriately to finishing work. Milling cutters are very widely used for the finest kind of surfacing; and that at considerably increased speeds or feeds — generally the former where especially good surfaces are required.

**And High-Speed Shaving Too!**—The ability to hold a keen edge, such as is presupposed where finishing cuts are concerned, has been facetiously referred to in connection with high speed steel razors, wherewith the busy man might indulge in high-speed shaving — the hope being also facetiously expressed that in this case the depth of cut be not unduly increased. Whatever may be the humor in such a situation, it is said to be a fact that certain “safety” razor blades of exceptional edge-keeping quality are made of high-speed steel. Occasionally also one

comes across a knife, or other cutting tool, not intended for use upon metal, of the same material. One of the severest tests of keen edge-holding quality is paper cutting; and high-speed knives in paper-cutting machines are not to be compared with carbon steel knives in this respect. The same thing is true of other kinds of work that could be mentioned — in wood-working especially.

**In Non-Metal Industries.**—Attention has been so concentrated upon the use of high-speed steel in metal-cutting operations that its utility in other and perhaps unrelated industries has been all but overlooked. Now that it has been demonstrated beyond question that high-speed cutters are highly efficient in wood-working and other besides the metal industries, it seems very probable that, as the writer predicted some years ago, there will shortly be as great a revolution in these as in metal-cutting industries. First used for wood-planer knives, high-speed steel is already largely employed for almost all sorts of wood-working cutters; and there is every reason why it should be used still more largely.

**Efficiency in Planing and Forming.**—The cutting speeds obtainable with the old tools, applied to wood-cutting, have seemed already tolerably good. With the new steels, however, the feed (the reference now is to surface and form cutting) can easily be doubled and a much better

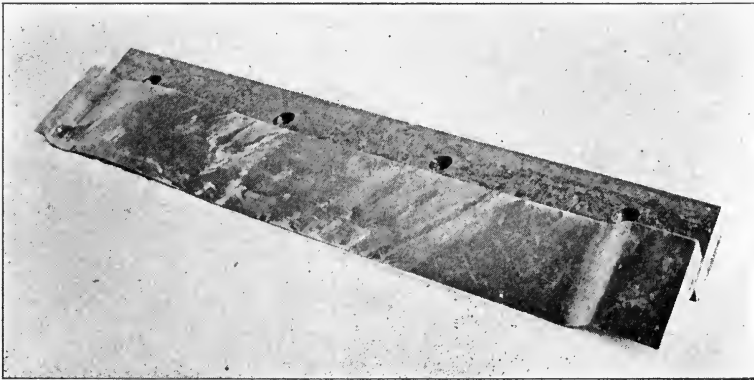

FIG. 168. Back knife for woodwork. Back made of soft steel. High-speed steel blade riveted on.

finish obtained at the same time. Sixty feet a minute, as wood workers know, is considered a very high feed in planing and the like operations, and half as much is more nearly the average in most shops. With high-speed cutters a feed of a hundred and more feet is entirely practicable, regardless of the kind of wood — hard or soft, it is a matter of indifference to the knives. And the finish obtained has very little resemblance to that succession of ridges and depressions, the knife marks to which we have been so long accustomed. It is, on the other hand, smooth and satiny, more nearly comparable to the surface left by the sander or the hand

plane. Forming cutter heads show the same characteristics of smooth finish and possible increased feed.

**A Case in Point.**—The knives are able to cut faster because they retain a keen edge better and longer, and can actually be given sharper cutting edges than is permitted to carbon cutters, in which latter a very keen edge cannot be expected to stand up to the work for a satisfactory length of time. The edges, in all kinds of wood cutting, hold up remarkably, as may be seen from a typical instance. In a certain job of cutting dowels from very hard maple sticks, an ordinary cutter could not be made to work longer than half an hour without re-honing. Even then it was necessary to set up the knife several times in order to get the dowels properly sized. A high speed steel cutter easily runs thirty

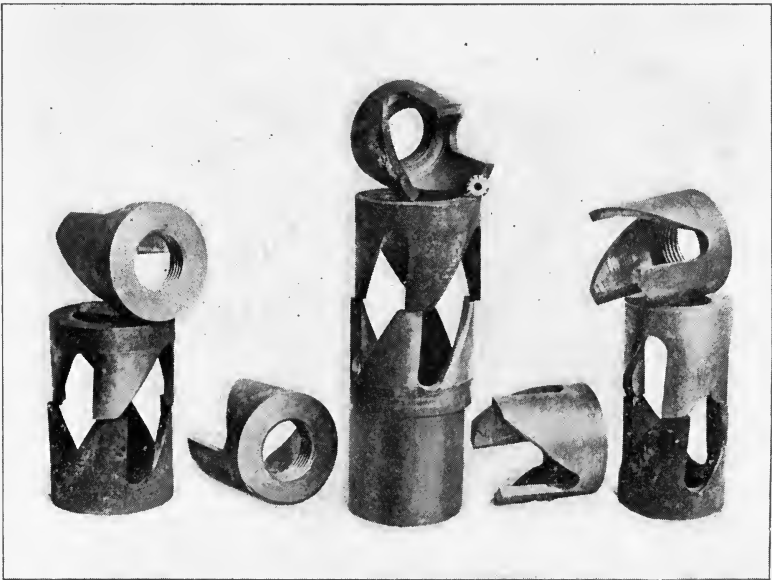

FIG. 169. High-speed hollow mills showing a high efficiency.

hours without sharpening, and at the end of that time is in excellent condition, apparently able to run considerably longer without any need for setting up. This is an efficiency of over sixty to one in the matter of sharpening alone, saying nothing at all of a possible increased rate of cutting. In most wood-working jobs, sawing among the rest, the tools easily keep their edges from three to ten or fifteen times as long as the ordinary ones. The saving of time under these conditions is very evident. It is the more marked also since the tools can be readily designed so as to permit sharpening without removing the cutting blades (in tools of this type) from the heads or revolving holders.

It scarcely need be added that the cutters, as far as practicable, are

most economically made composite, that is, in the form of holders of iron or ordinary steel provided with thin cutting blades suitably clamped in place.

**Cutting Soft Metals.**—The question has often been raised concerning the economy of high-speed steel in cutting brass and metals other than iron and steel; and most usually it has been said that there is little if any advantage. This is by no means the universal experience, for in certain shops they are used with a distinct saving on brass cutting; while in working other metals, as bronze and German silver, the saving in grinding is very marked indeed. An experience in milling German silver pieces is indicative of the many others. A high-speed cutter is in better condition after milling 5000 of a certain piece than is a carbon cutter after milling only 100 of the same piece.

**Tools Subjected to Abrasion.**—Though apparently but little used for such purposes, outside of the metal-forming and shearing jobs, as already indicated, the new steels have been found efficient in a great variety of other operations involving heavy wear or abrasion. Among these are the drilling and surfacing of rock, marble and building stone generally.

**Not All Steels Widely Adaptable.**—In conclusion it should be pointed out that there are high-speed steels, and still yet high-speed steels. And while it is quite true that such steel is available and efficient in all the processes just indicated, and in many others as well, it does not necessarily follow that any one brand is adapted to all these several uses. Indeed, most of them are not, though a very few seem to be of a composition which adapts them surprisingly well to a very great range of work. Others are more particularly adapted to certain kinds of operations; and still others seem to be altogether inferior.

## CHAPTER XV.

### CONDITIONS OF MAXIMUM EFFECT.

**Bringing Together Tool and Work.**—Besides the two things ordinarily considered in bringing together a tool and a piece of work, namely the nature of the tool, and the form of the machine adapted to its most efficient application to the work to be done, there is a third consideration fully as important as these, and not at all rarely more so; and that is the proper bringing together of the tool and the piece to be worked. The form and type of machine by which such a relation is established of course is determined largely by the form of the tool selected and the nature of the work to be done; and in respect of this it is necessary to say little here, though it may be pointed out that the new steels have emphasized very strongly the tendency away from reciprocating machine tools and toward those in which either tool or work rotates.

**Effect of Multiplex Adjustments.**—Until lately (and apparently yet, to a considerable extent) the primary end in machine design has been to secure facility; and to satisfy this requirement, movements and adjustments have been multiplied in standard machines until the tool-holding and applying mechanisms have not infrequently been made more mobile than rigid. The need for rigidity in the tool and work relation has been well enough recognized, though possibly lost sight of at times. In the new conditions imposed by high-speed tools rigidity and solidity are imperative. They are conditions without which there can be no such thing as efficiency. Hence it is of first importance that tool and work be brought together with the least possible intervention of parts and joints, and at as short a distance from the bed or frame of the machine as may be. Fortunately, as elsewhere shown, the large use of jigs and fixtures, in general manufacturing at any rate, makes a great variety of adjustments superfluous, and it becomes possible to have tool-holding and work-holding devices simple and rigid.

**Chatter.**—Such a requirement is necessitated not only in order to insure a finish of the specified excellence, but from considerations affecting the life of the tool as well. At the very best the tool and its supports, together with the other parts intervening between work and tool, and serving to hold them in proper relation, are in the nature of a spring under tension while cutting is taking place. This being so, it follows that with every variation in the pressure upon the tool end of the spring there is a corresponding variation in the tension, and consequently there



is a tendency toward vibration. The phenomenon of chattering, as seen in machine tools too light for the work to be done or too much worn to insure smooth running, is well enough known. But it is not so well known that under the very best conditions more or less vibration still is present, even in such tools as drills, reamers, milling cutters, and

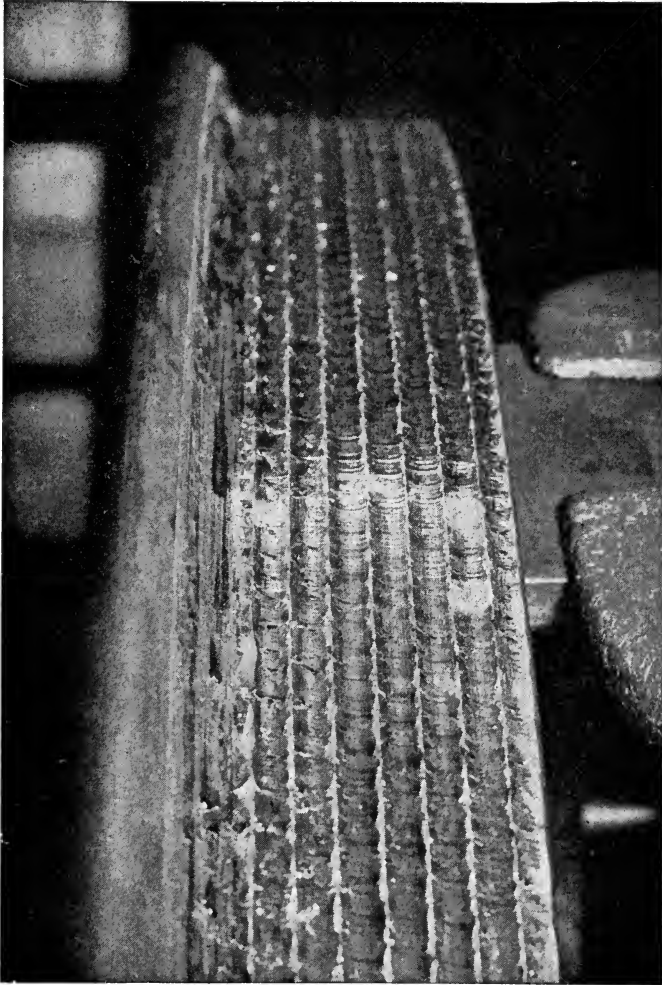

FIG. 170. Roughing cut, locomotive tire turning. The conditions were excellent, but vibration is clearly evident.

the rest. The usual opinion is that there is no quivering if no chattering is heard and no vibration felt. The investigations of Dr. Nicholson have proved not only that pressure oscillations are always present, but that there is a definite relation between them and the character of the chip removed. A little study of the nature of chips, and the sur-

face left by a tool, especially when very heavy cuts have been taken, shows the same thing conclusively. This is clearly shown in the accompanying illustrations of locomotive tire turning, Figs. 170, 171 and 172, one showing a roughing cut, a second a finishing cut, and a third the chips roughed off. In the doing of this work the conditions were made as nearly perfect as possible, and the lathe used was of a type and build to prevent doubt as to its rigidity.



FIG. 171. Tread of locomotive tire after finishing.  
Note corrugations indicating vibration of tool.

**Lateral Vibrations.**—It is seen that corrugations left by the tool, Fig. 170, and serrations or waves found upon the top of the chip, Fig. 172, have a rather regular recurrence and form. The same thing may be observed in other illustrations showing chips, whether the latter be large or small. It is apparent also that vibrations take place laterally as well as perpendicularly to the lip of the tool; and the Nicholson experiments, already referred to, have shown that the wave-like variations in pressure at right angles to the finished face correspond very closely with those resulting from the thrust away from the face and therefore perpendicular to it. Not that these two (and more than likely also quiverings in other directions, especially in the line of the feed or traverse) are distinctly

separate. They are, as may be seen in the illustrations already referred to, combined into one resultant, which gives to the cutting edge of the tool a movement approximating the arc of a circle.

**Minimizing Vibration.**—The importance, in respect of the finished work, of reducing this vibration to the lowest terms is obvious. It is no less important to the life of the tool itself, for it is this to a very large extent which destroys the cutting edge, and necessitates more or less frequent grindings according as conditions are more or less excellent. Under ideal conditions the tool would practically sharpen itself, while working, and its cutting life would accordingly be greatly prolonged.

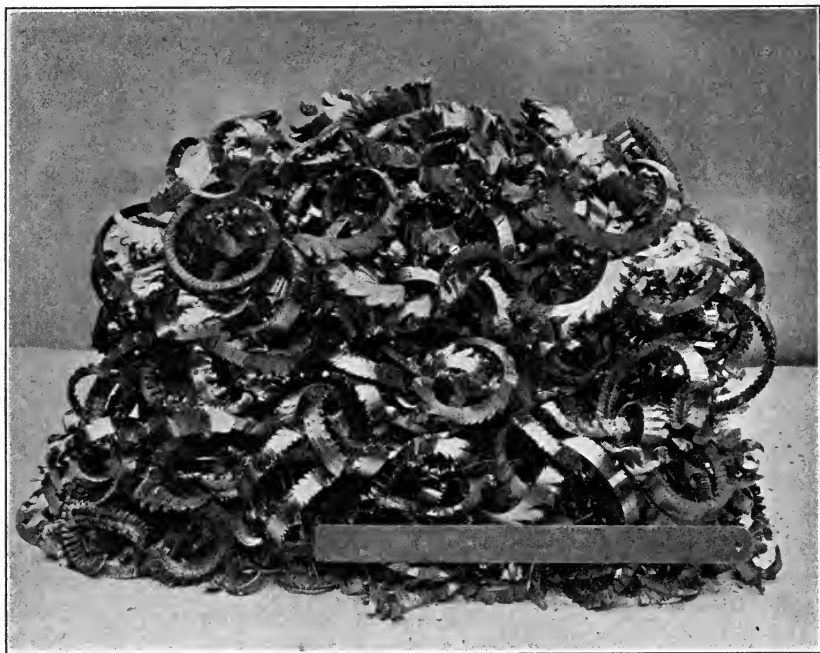

FIG. 172. Chips taken in turning locomotive tires, with conditions as well arranged as possible.

Inasmuch as this prolongation of the life (that is, the lengthening of the time during which a tool will do its maximum amount of work without necessitating re-grinding) is one of the most important factors in the use of high-speed tools in general manufacturing, it is necessary to work the tool under those conditions which are most favorable to the accomplishment of that object in the highest degree. A brief inquiry into the nature of the cutting operation, therefore, is in order.

**Action of Ordinary Cutting Tools.**—A wood-cutting tool works with a sort of splitting action. The sharp edge is forced across or through the material, which is then pushed apart by the faces of the thin wedge behind

the cutting edge. The fibers thus are separated and a crack is opened which tends to precede the edge of the tool a greater or less distance according to the sharpness or bluntness of the cutting angle and the tenacity or brittleness of the material being cut. As the tool advances, the tendency is for the shaving to break, split, or shear as it is bent farther and farther from the straight, until perhaps it quite separates from the preceding portions. In cutting across the grain of wood, say, this is seen very clearly. Now in the case of the Hartness "sharp edge" tools and method of metal cutting the action seems to be very similar. The essential difference lies in the absence of fiber in the material cut, so that there is a sort of shearing of the chip as the cutting progresses,

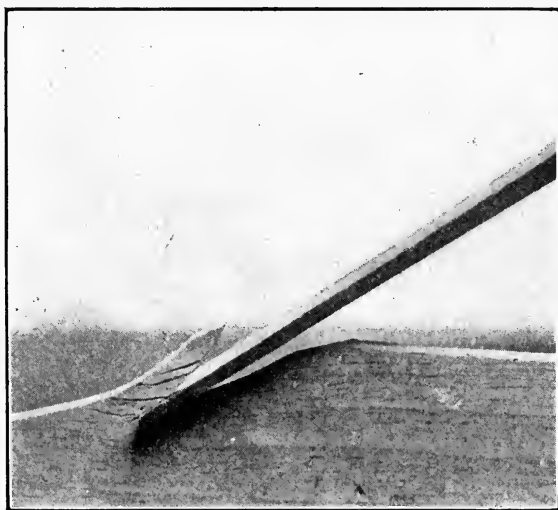

FIG. 173. How a wood-cutting tool acts.

instead of a splitting apart of the fibers. Since all the flanks of such a tool ride against or are pressed upon by either the chip or the stock left, and the tool itself is free to move within a slight range, the cutting edge tends to sharpen itself and there is very little tendency for it to be broken off or to crumble away by any lateral movement, as is the case with tools of the ordinary form.

**Theory of Metal Cutting.**—The action of a cutting tool as customarily designed and used, though in some respects similar to that described, yet differs in important respects. While the cutting part of such a tool is in the form of a wedge, and acts a good deal like one in first entering the metal, after the chip is once fully started the action is rather that of tearing away the chip from the mass of metal and scraping the rough surface left by the chip, the chip being the while broken or sheared into

smaller or larger sections, as the case may be. Certain observations and conclusions with reference to these phenomena were published some time ago by the present author. Since that time Mr. Taylor has published<sup>1</sup> further and amplified observations which cover the ground so thoroughly that his words are here quoted at length, with some slight adaptation.

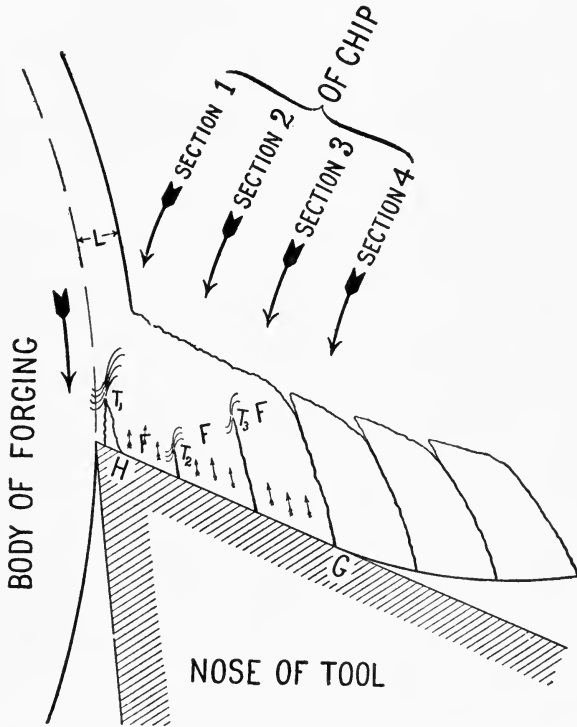

Fig. 174. How a chip is taken and sheared into sections in cutting steel.

“The enlarged view of chip, tool, and forging shown, Fig. 174, represents with fair accuracy the relative proportions which the shaving cut from a forging of mild steel (say 60,000 pounds tensile strength and 33 per cent stretch) finally assumes with relation to the original thickness of the layer of metal which the tool is about to remove. It is of course impossible to determine accurately the extent to which various parts of the chip and forging close to the tool are under compression and tension, but in general the theory advanced is believed to be correct.

<sup>1</sup> “On the Art of Cutting Metals,” by Mr. Fred W. Taylor; being his presidential address at the opening of the annual meeting of the American Society of Mechanical Engineers, December, 1906. Published by the Society. Practically all references and allusions to Mr. Taylor’s work and conclusions are based upon this address. From it also are taken the illustrations to which references are made in the quotation, as well as a number of others.

**Distortion of Shaving.**—"The thickness of the layer of metal to be removed is indicated on the same enlarged scale as the rest of the figure by L, Fig. 174, between the dotted line and the full line representing the outside of the forging. It will be observed that the chip is in process of being torn apart and broken up into three sections, between which the shearing action or cleavage has progressed to a greater or less extent according to the distance from the cutting edge. It will be noticed that the width of the sections is at their bases about double the thickness of the original layer of metal removed, and that their upper portions are not enlarged to the same extent. These sections are about three times as high as the original layer. It should be clearly understood that the dimensions of the sections will vary according to the hardness of the metal being cut, and also to a certain extent with the angles of the cutting

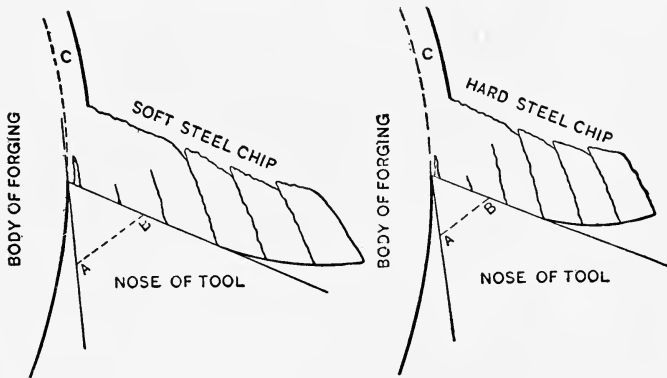

FIG. 175. How hard and soft chips bear upon the lip surface of tool. The soft chip covers a much larger area of the lip surface.

tool. The harder the metal being cut, the less will each section of the chip be enlarged. In other words, if the same shaped tool be used in each case, the chip from soft metal comes off very much more distorted than that from the harder steel. This explains why the total pressure on the tool has but little relation to either the hardness of the metal being cut or the attainable cutting speed.

**Explanation of the Figure.**—"The chip bears on the surface of the forging, say, from point *H* to point *G* (Fig. 174), and through this distance is under constant compression from the lip surface of the tool. This compression is transmitted through each of the sections 1 and 2 of the chip, in the direction indicated by the arrows, to the upper portions of the sections, which are still unbroken and which act like a lever attached to the upper part of section 1 to tear that section away from the body of the forging, as indicated at point  $T_1$ . The tearing away of section 1 is assisted also by the pressure of the tool upon its lower surface. After

this tearing action has started, the further breaking of the chip into independent sections would seem to be that of simple shearing. It should be borne in mind that in shearing a thick piece of steel the whole piece is not shorn or cut apart at the same instant, but the line at which rupture or cleavage takes place progresses from one surface through the metal until within a short distance from the other surface, when the whole remaining section rather suddenly gives way. In shearing steel, the metal at the point of rupture is pulled apart under a tensile strain, although on each side of the shearing line it is under heavy compression.

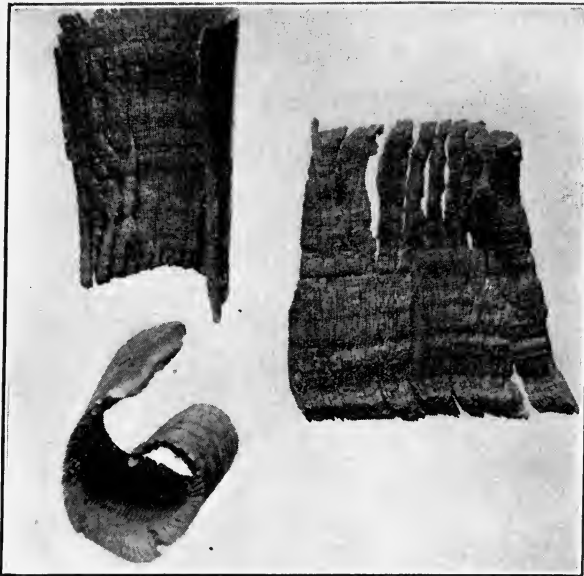
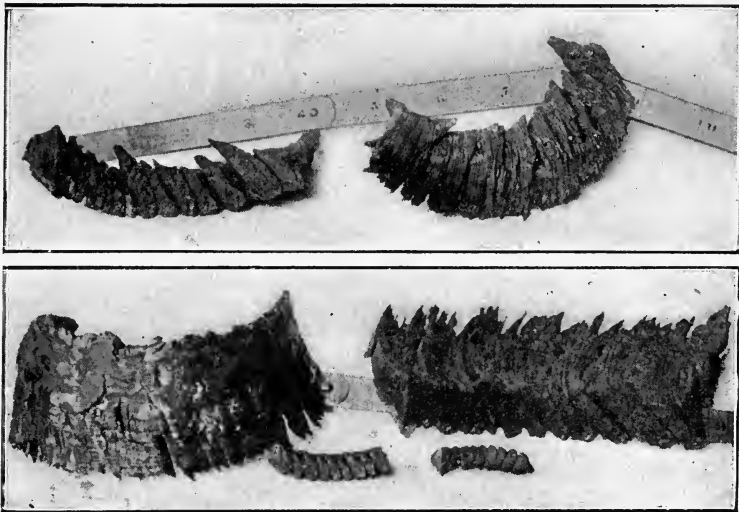

FIG. 176. Structure of wide and relatively thin chip. Cut from armor plate.

**Shearing Action.**—“As each of the sections of the chip successively comes in contact with the lip of the tool, its lower surface is crushed and the metal flows out laterally until it becomes about twice its original thickness or width. As in all shearing, when the full capacity of the metal for flowing has been reached, it tears apart under tensile strain from the body of the adjoining metal of the forging. The compression on the chip from the tool continues, however, and the chip continues to flow and spread sideways at a part farther from the tool surface, say at the points marked *F*. In the same way shearing continually takes place along the left side of the portion of the chip which is flowing or spreading out sideways. There is no question that shearing takes place constantly along the left-hand edges of two of the sections at the same time, and it is

probable that this action occurs most of the time along three lines of cleavage.

**Maximum and Minimum Pressures.**—“ Dr. Nicholson’s dynamometer experiments show that the pressure of the chip on the tool in cutting a chip of uniform section varies with wave-like regularity, and that the smallest pressure of the chip is not less than two-thirds of the greatest. From this it is evident that shearing must be taking place along at least two lines of cleavage at the same time; since if each of the sections into which the chip is divided were completely broken off before the tool began to break off the following section, there must be times when there would be almost no pressure on the tool.



FIGS. 177 and 178 Illustration of the shearing of a chip into sections. The series formation, indicating vibrations of long wave length, is well shown.

**Shearing of Chip at Three Points.**—“ It is at first difficult to see how it can be possible for the chip to be shearing at two or three places at the same time. It should be noted, however, that above the points  $T_1$ ,  $T_2$ , and  $T_3$  the metal of the chip is still a solid part of the forging, and moves down at the same speed as the forging, in a single mass or body, toward the lip surface of the tool, and with sufficient force to cause each of the three sections of the chip to flow or spread out at the parts indicated by the three letters  $F$ . According to the laws governing shearing, rupture or cleavage in each case must take place as soon as the maximum possibility for flowing has been reached, and in each case shearing must occur at the left of the zone where the metal is flowing. It is probable that after the shearing action has progressed in section 3 to about the point



indicated by  $T_3$ , the whole of this section gives way or shears with a rather sudden yielding of the metal from  $T_3$  to the upper surface of the chip. It is this rather sudden shearing which undoubtedly causes the wave-like diminution in the pressure of the chip indicated in Dr. Nicholson's experiments.

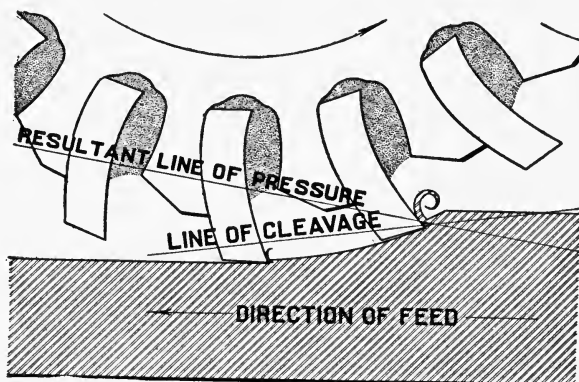

FIG. 179. How the chip is removed — milling. Cutting edge of blade not under heavy pressure. Courtesy of Tabor Manufacturing Company.

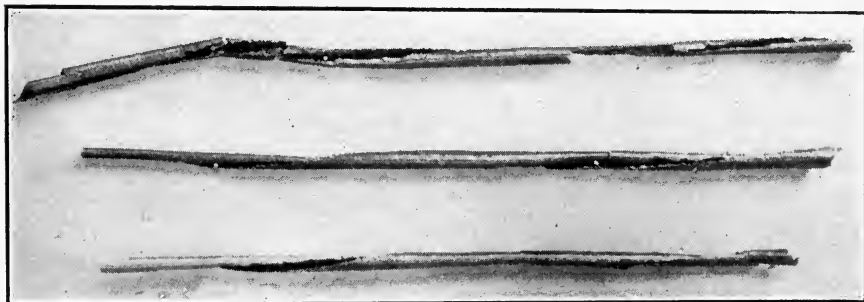

FIG. 180. Chips milled from a steel forging. Courtesy of Tabor Manufacturing Company.

**Chip Torn from Body of Work.**—“ It would appear that the chip is torn off from the forging at a point appreciably above the cutting edge of the tool, and that this tearing action leaves the forging in all cases more or less jagged or irregular at the exact spot where the chip is pulled away, as shown to the left of  $T_1$ . An instant later the line of the cutting edge, or more correctly speaking, the portion of the lip surface immediately adjoining the cutting edge, comes in contact with these slight irregularities and shears off the lumps so as to leave the receding flank of the forging comparatively smooth. Thus in this tearing action, particularly in the case of cutting a thick shaving, while the cutting edge of the tool is continually in action, scraping or shearing off or rubbing

away these small irregularities left on the forging, yet that portion of the lip surface close to the cutting edge constantly receives much less pressure from the chip than the same surface receives at a slight distance beyond. This allows the tool to run at a higher cutting speed than would be possible if the cutting edge received the same pressure as does the lip surface close to it.

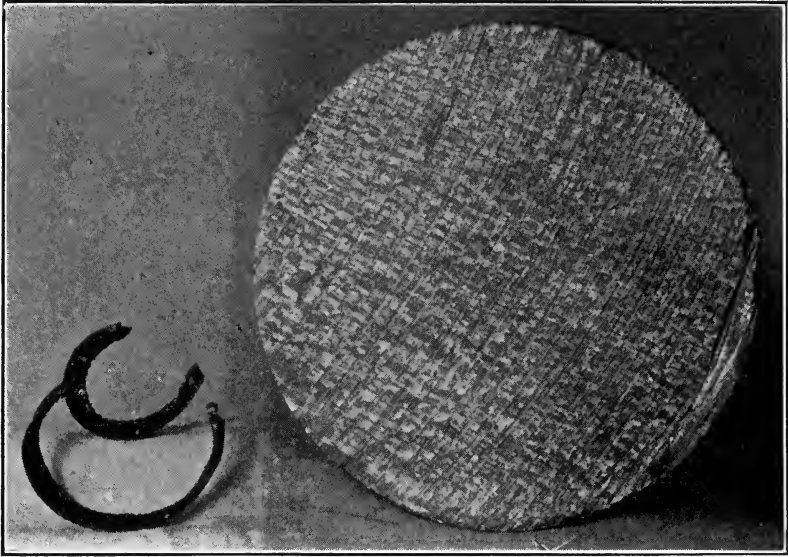

FIG. 181. Some "sawdust" and a sawed surface.

**Evidences of Tearing Action.**—“There are many phenomena which indicate this tearing action of the tool. For example, it is an everyday occurrence to see cutting tools which have been running close to their maximum speeds and which have been cutting for a considerable length of time, guttered at a little distance back from the cutting edge, Fig. 182. The wear in this spot indicates that the pressure of the chip has been most severe at a little distance back from the edge.

“Still another manner in which the tearing action of the tool is indicated is the case where a small mass of metal is found stuck fast to the lip surface of the tool, Fig. 183, after it has completed its work and been removed from the lathe. When broken off, however, and carefully examined, this mass is found to consist of a great number of small particles which have been cut or scraped off the forging as above described, by the cutting edge of the tool. They have been pressed down into a dense pile of compacted particles of metal stuck together and to the lip surface of the tool, almost as if welded. In the case of modern high-speed tools, when this little mass of particles is removed, the cut-

ting edge of the tool is in most cases found about as sharp as ever, and the adjacent lip surface not infrequently shows the scratches left by the emery wheel from the original grinding."

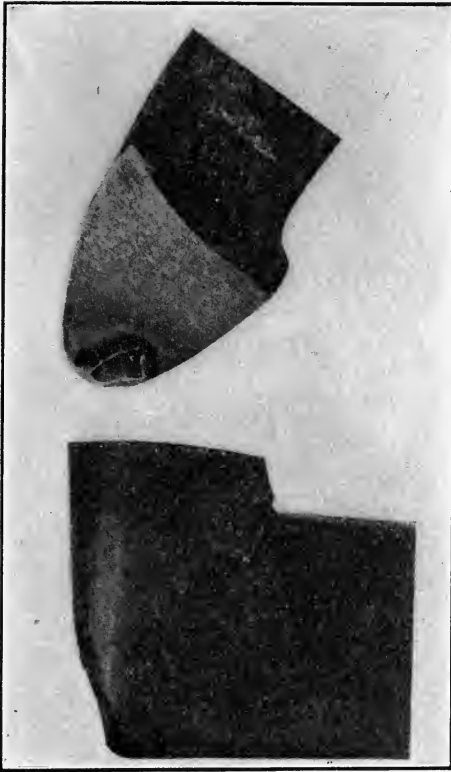

FIG. 182. Cutting edge still good but deep groove worn or guttered in the lip surface by the pressure of the chip.



FIG. 183. Small particles of the chips scraped from the forging and pressed into a compact pile upon the lip surface of the tool.

**Difficulty of Machining Cast Iron.**—This peculiarity in metal cutting seems to explain why it is not possible to machine cast iron and other brittle materials as rapidly as steel and other tenacious substances. In the latter case the chip is split off from the main body with a line of cleavage extending some distance ahead of the cutting edge, and tending more or less to follow the direction of the cut; whereas in the former case the brittleness of the material tends to prevent the line of cleavage advancing much, if any, beyond the cutting edge, while at the same time its direction tends immediately toward the surface of the chip rather than in the direction of the cut. In consequence the edge of the tool has a great deal more work to do, scraping or shearing off the relatively

much greater amount of material left behind by the chip in breaking off from the main mass. The tendency, therefore, is for the edge to wear away rapidly.



FIG. 184. Typical chips made in cutting cast iron.

**Wear of Tool in Steel Turning.**—In the case of steel cutting, say, the major part of the work falls upon the well-supported lip surface back of the edge, the distance depending upon the nature of the material and the feed or depth of cut. The rubbing of the chip tends gradually to wear a depression or pit into the lip surface, the form and place varying according, among other things, to the nature of the material being cut and the rake of the tool. If the cutting speed and its concomitants are such as to generate a great deal of heat which cannot be conducted

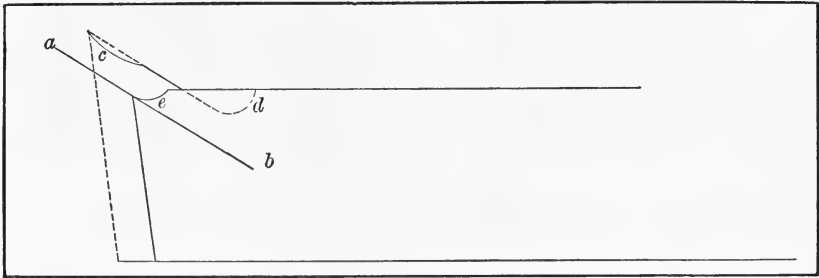

*The Engineering Magazine*

FIG. 185. The line *ab* indicates the rake or slant which in this particular case would allow the tool to work at its greatest efficiency, for it is the slant established by the abrasive action of the chip itself. The dotted line indicates what would be the ideal tool in this case but for other considerations.

away rapidly enough to keep the tool below the temperature where softening takes place, the lip surface quickly wears away along with the softened cutting edge. When, however, the temperature of the cutting edge and the adjacent parts is kept below the softening point, the abrasion of the lip surface takes place gradually and rather uniformly, the tendency being to form a hollow whose front surface forms a sharper angle with the clearance flank of the tool, and therefore gives a sharper cutting angle to the tool as it approaches the edge. As this angle becomes still smaller the cutting edge has less and less support, and tends

to wear more and more rapidly, or to crumble away under lateral vibration. This latter, together with the quivering in the line of the cut



FIG. 186. Tool run at such high speed as to be ruined while cutting.



FIG. 187. Wear on tool run at proper speed. Tool still in good condition.

already referred to, subjects the cutting edge to a succession of blows, which tend to break it over somewhat as is the case when a piece of wood is scraped with the edge of a freshly broken glass. Immediately the edge becomes nicked, be it ever so slightly, the whole of it very rapidly goes down, generally by reason of the increased heating attendant upon the rubbing of the damaged part against the work, instead of shearing away the material as before.

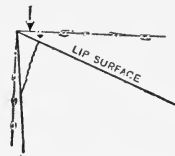

FIG. 188. Spalling of tool point by downward pressure of chip.

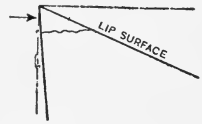

FIG. 189. Spalling of tool point by pressure on clearance flank due to feeding tool into the work.

**Problems in Metal Cutting.**—Assuming that the machine and the tool and work holding devices are as rigid as possible, three other problems are involved in this condition: How to reduce quivering to the irreducible minimum; the development of practical maxima in cutting speeds in connection with methods for cooling or lubricating tools; and the establishment of definite cutting life periods (times after which re-grinding is to take place) for the tools.

**Pressure Variations and Chatter.**—It may be well here to point out that what is ordinarily called chattering is not at all the same thing as the wave-like variation of pressure upon the tool while cutting, though the latter may, and often does, cause or develop into the former. If it were possible to obtain absolute rigidity, the variation in pressure would be of no consequence, so far as the effect upon the tool or the work is concerned; but this, as already pointed out, can be approximated merely, and that under the very best conditions only. In considering the best forms for tools (see *Design of High-Speed Tools*) it is shown that the wave lengths of the quiverings vary somewhat according to the thickness of the shaving, and that if a round-nosed tool be used so as to take a chip whose thickness varies progressively from zero to the maximum, the tendency is for the various waves to neutralize one another; while, on the other hand, if the chip be taken straight and therefore of uniform thickness, the pressure variations easily are converted into actual movements of the cutting end of the tool, with bad results to both tool and work. Of course, even with round-nosed tools (and these are by no means available in every case) the pressure waves exist; and sometimes it becomes a problem, especially if other conditions cannot well be brought to the point required by highest efficiency, how to mitigate the evil. Particularly in taking light cuts, if there is any possibility of the work or of the machine springing even a little, the tendency will be for the tool, especially if a little dull, to jump out of the cut and to ride upon the unfinished surface more or less. This sometimes will happen to a sharp tool as well. The consequences to the tool, saying nothing of the work, are evident. An expedient which is likely to help some is to modify the clearance angle of the tool slightly, so as to permit it to ride upon the finished flank of the piece operated upon, the cutting edge or extreme point being at the same time elevated very slightly above the center line.

**Effect of Increased Depth of Cut.**—In taking such a thin chip all the work falls very close to the cutting edge anyway, and quivering is all but certain to cause the ruin of the tool in a very short time, thus occasioning frequent grindings and much loss of time. The paradoxical alternative is to give the tool more work to do — that is, to increase the depth of cut, and perhaps also the feed. This will have a tendency to put the tool under stress sufficient to take up all the slack in the circle

of parts extending from the point of the tool through the holding devices, machine frame or bed, and piece worked upon. It may in this case be necessary to decrease the speed somewhat, though this will depend upon the length of the cut and a number of other contingencies. Recent investigations seem to indicate that increased speed has somewhat the same effect as increased depth of cut or feed, in prolonging the life of the tool.

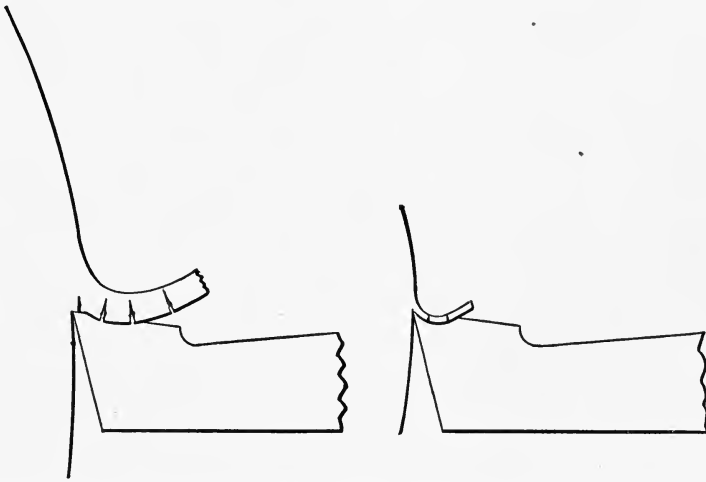

FIG. 190. The tendency of a thick chip (deep cut) is to wear a pit or hollow some distance back of the edge, the latter having comparatively little work to do and standing up for a long time. In the case of a thin chip the wear comes closer to the edge, which tends, therefore, to crumble or break down.

**Change Necessary in Size of Pieces.**—Increasing the depth of cut, under the conditions indicated, obviously involves a change in the size of the piece to be machined. In the case of castings nothing is gained by excessively close molding, and an ample margin to allow a good depth of cut can just as well be left as not — unless possibly in small shops purchasing castings by the pound, where the loss in turnings might perhaps exceed a gain such as pointed out. In steel forgings or bars turned down this matter of the cost of the turnings may well be considered, though ordinarily it will be found good practice to allow ample margin in any case. Unnecessary excess of size obviously is to be avoided also, since it involves merely the useless handling of material and absorption of power at the machine. In finishing malleable castings, it is to be remembered also, the tough or steely portion lies in and adjacent to the surface, forming a skin, so to speak. If this is removed to any considerable depth, the casting loses much of its strength. It is quite safe, under ordinary circumstances, to take a finishing cut of  $\frac{1}{16}$  inch on malleable castings; and this is sufficient to allow the tool to take a good hold. Unless they should be quite large or so peculiarly shaped as to be especially susceptible to warping or likely to be badly

cored, the same depth is sufficient in cutting gray iron castings. Unusual conditions, of course, may necessitate a greater allowance.

**Relation of Cutting Speed to Chatter.**—There seems to be some evidence that, other conditions being as carefully arranged as possible, the cutting speed has something to do with chatter. No extended investigation seems as yet to have been made of this circumstance; though it is known that while under a given set of conditions as to rigidity, cut, speed, and the like, there may be no chatter sufficient to be particularly harmful, yet if the speed is materially increased chattering will occur.<sup>1</sup> The quivering becomes the more important also as the cutting speed is lowered. The importance of this phenomenon suggests the need for a careful inquiry into the causes and methods of prevention, and in the meantime of taking note of it as a possible element in fixing speeds.

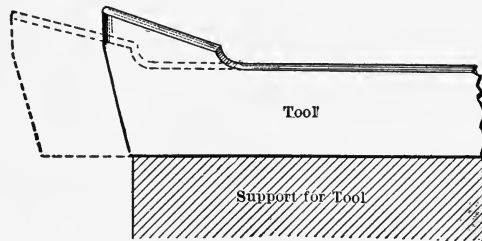
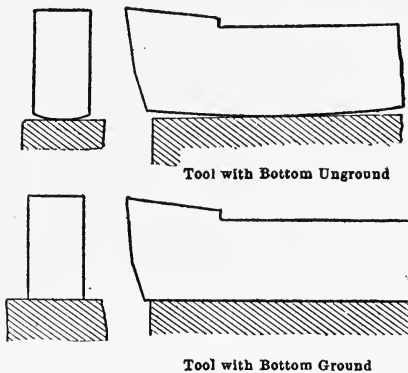

FIG. 191. Correct method of supporting tool. The dotted lines show the ordinary method of support with too much overhang.

**Overhang of the Tool.**—The need for extreme rigidity in holding the tool to the work has been alluded to. This condition very obviously

involves, along with other things previously considered, a minimum overhang of the tool with respect to its support. Likewise it involves correctly formed bases in both tool and support. The lack of attention to this detail is no doubt responsible for much trouble. The tool base can of course be left moderately flat in forging; and some attention should be given to this point. The safe way, however, is to grind the base true. The nature of the trouble is indicated by the accompanying illustrations,



FIGS. 192 and 193. Properly and improperly ground tool bases. Exaggerated to indicate clearly the effect of inattention to this important detail.

<sup>1</sup> Although Mr. Herbert's investigations, already referred to above, seem to indicate that under certain conditions increased speed tends to increase the endurance of a tool; whence it might be inferred that chattering would be reduced. Those interested are referred to Mr. Herbert's presentation of his "cube law" (cutting speed varies inversely as the cube root of the product of the feed by the area of the cut) at page 1063, *American Machinist* for June 24, 1809.



Figs. 192 and 193, in which the unevenness of the tool base is greatly exaggerated.

**Conditions Common to all Tools.**—All that has thus far been said with respect to vibration and chattering applies with substantially equal force to all forms of cutting tools, and to those made of carbon steel

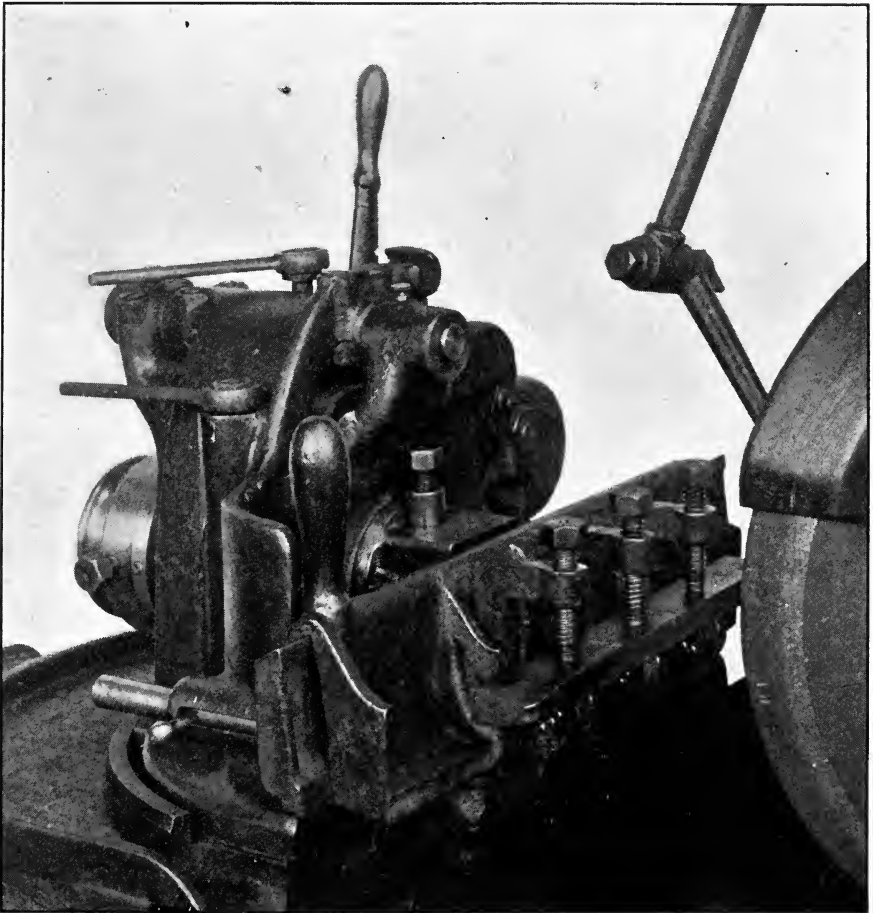

FIG. 194. Truing up a lathe tool base on a Sellers grinder by use of a supplemental chuck.

as well as those of high-speed steel. The matter of overhang and sufficient support, for example, just mentioned, is fully as important in the case of rotating tools like milling cutters as it is in those like lathe and planer tools. It is of vital importance that the cutter be brought as near as may be to the spindle and arbor bearings (the shortness and rigidity of these having been provided for in the design of the machine) and that the diameter of the cutter be small relative to that of the arbor

The diameter of the cutter beyond the arbor corresponds approximately to the overhang of a lathe or planer tool, and the smaller this can be permitted, the less the liability to chatter.

**Grinding Rotary Tools.**—In rotary tools, too, the matter of accurate grinding and keeping sharp edges is possibly of greater importance than in the case of others. A milling cutter which has been ground eccentric to a very slight amount, for example, is almost sure to chatter; and the more so if run at high speed. The necessity for careful grinding in machines suitably designed for the purpose, therefore, is evident. The subject is elaborated in another place (the chapter on grinding), and it is sufficient here to point out that besides the chattering accompanying imperfect grinding of rotating tools, drills, reamers, and the like, the unevenness certain to result from hand grinding involves some of the lips doing more work than others, taking deeper cuts, and therefore wearing more rapidly, and correspondingly shortening the life of a grinding — to say nothing of the effect upon the accuracy of the work. It is altogether likely that the unfavorable experiences sometimes heard of, as to finishing surfaces with high-speed tools, are very largely due to inaccurate grinding or to lack of foresight in providing against chatter, as just shown.

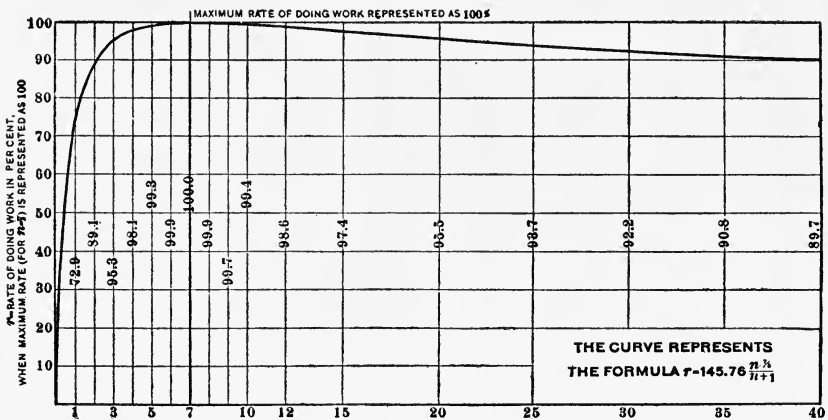

FIG. 195. How long a tool should run without re-grinding.

This diagram shows that, in order to do the largest amount of work for the lowest all-round cost, a tool should be allowed to cut continuously without grinding at least seven times the time lost in changing the tool, plus the proper portion of the time for redressing, time for grinding, and the time equivalent of the cost of the tool steel.

**Standard Running Time.**—Whatever the form of the tool, it should be possible to establish with a good deal of certainty the standard time for running, at the end of which the tool is to be laid aside for grinding. This time, whether standardized or not, is to be shorter than that required for the ruin of the tool. That is to say, no tool should be run until the edge has broken down, or even begun to break down, but somewhat

TABLE VIII.

Size of body of tool in inches.	Time to re-dress tool, in minutes.	Number of re-grindings for each re-dressing.	Proportionate time of re-dressing for each re-grinding, in minutes.	Proportionate time of re-dressing for each re-grinding, converted into equivalent time for machine.	A	Time to grind tools, in minutes.	B	Cost of tool steel lost for each re-dressing, in cents.	Cost of tool steel for each re-grinding, in cents.	C	D	t	T-7t	10t	Time we recommend the tool be run before re-grinding, that is, 10t in even figures, in hours and minutes.	Size of body of tool, in inches.
1/4 x 1/4	8.8	13	0.677	1.130	2.2	3.67	9	0.69	1.38	1.5	7.7	54	77	1-15	1/4 x 1/4	
1/2 x 1/2	9.2	15	0.613	0.766	2.4	3.00	17	1.13	1.69	1.6	7.0	49	70	1-15	1/2 x 1/2	
3/4 x 3/4	9.7	17	0.571	0.571	2.6	2.60	30	1.76	2.11	1.7	7.7	54	77	1-15	3/4 x 3/4	
1 x 1	10.3	18	0.572	0.477	2.8	2.33	47	2.61	2.61	2.8	8.2	57	82	1-30	1 x 1	
1 1/4 x 1 1/4	11.0	19	0.579	0.414	3.0	2.14	70	3.68	3.16	3.0	8.7	61	87	1-30	1 1/4 x 1 1/4	
1 1/2 x 1 1/2	12.7	20	0.635	0.353	3.6	2.00	137	6.85	4.57	3.3	10.2	71	102	1-45	1 1/2 x 1 1/2	
1 3/4 x 1 3/4	14.8	20	0.740	0.336	4.3	1.95	236	11.80	6.44	3.6	12.3	86	123	2-00	1 3/4 x 1 3/4	
2 x 2	17.2	20	0.860	0.331	5.1	1.96	375	18.75	8.66	4.0	15.0	105	150	2-30	2 x 2	
2 1/2 x 3	20.0	20	1.000	0.333	6.0	2.00	448	22.40	8.96	4.5	15.8	110	158	2-45	2 1/2 x 3	

DATA FROM WHICH TO DECIDE HOW LONG EACH SIZED TOOL SHOULD BE RUN BEFORE BEING RE-GROUND. The periods of time given in columns for Re-dressing, Grinding and Changing Tools, were determined by many stop-watch observations. In the column headed t (heavy-faced type) are given the equivalent in the time of the machine operator and his machine, of the total time for re-dressing, grinding and setting tool, and the tool steel lost each time that the tool is re-ground.

From Taylor's "The Art of Cutting Metals."

Table refers to Taylor standard tools.

short of it. If the matter is left to the judgment of the workman it is necessary to observe carefully the approach of the wear on the lip surface to the cutting edge, and to remove the tool in ample time to avoid ruining the piece of work, or more likely both it and the tool. The length of time a tool will run without re-grinding, it may be added, is not necessarily a criterion of its excellence; and indeed it becomes one of the determining elements only when the tool is actually being run at its maximum capacity for speed.

**Lubrication or Cooling.**—In the first years of high-speed steel but little attention was generally paid to the matter of lubrication or cooling. The possibilities of the new tools, as exhibited under ordinary shop conditions and without cooling, perhaps were so far in advance of what had been previously accomplished that the possibility of getting still better results was overlooked. There is, however, a considerable gain in cutting speed to be made through a proper cooling of the tool, or rather of the chip at the point where cutting takes place, a gain asserted by those who have given the matter attention, to be as high as 35 or 40 per cent in steel cutting, and from a third to a half as great in cutting cast iron. On many jobs such a possible gain of course is to be taken into account, and provisions made for delivering a cooling agent in suitable quantity and at the proper place. In the case of many jobs, however, such as abound in general manufacturing, especially where the cutting time is brief compared with that during which the tool is not working, no lubrication is necessary; and indeed in most such cases the troublesomeness of a stream of water or oil much outweighs any probable advantage. In all automatic, and perhaps in most semi-automatic machine operations, especially if the pieces be small, the problem is different, and lubrication should by all means be provided, whether the material machined be castings or forgings.

**When Lubrication Takes Place.**—While the word is in common use in this connection, it really is a misnomer to speak of lubrication in connection with metal cutting under high-speed conditions, except possibly in such work as milling. Water would have practically no lubricating effect; and it is quite impossible to force oil or other substance between tool and chip in such a way as to do much, if any good, as a lubricant.<sup>1</sup> The purpose of the so-called lubricants in the main is merely to assist in carrying away heat from the place where the work is being done, thus keeping down the temperature of the cutting edge and lip of the tool below the point where softening will begin. In cutting with rotating tools, whose cutting edges are most of the time out of contact with the metal being cut, some actual lubrication evidently takes place, the friction between chip and cutter face being reduced if the exposed

<sup>1</sup> Although it is maintained by some, whose experience should entitle their opinions to weight, that lubrication really is effected to a degree worth taking into consideration.

portions of the cutting blades are kept completely wet with oil or similar lubricant. At any rate, in milling aluminum a beautiful and clean finish is obtainable, there being no piling up of particles of the soft metal upon the face of the tool, when paraffine oil is used copiously. This is useful also as a lubricant in machining brass.

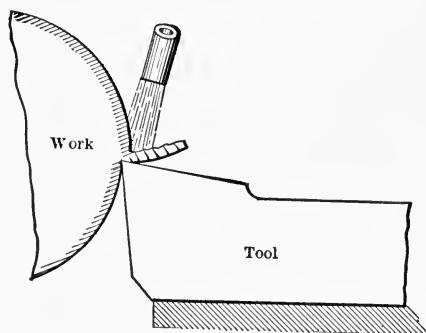
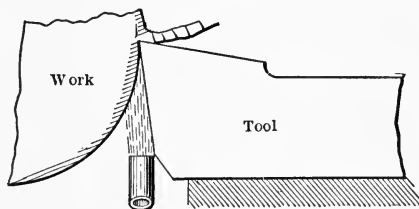

FIG. 196. Correct application of oil or water.

**Copious Lubrication Necessary.**—In the case of milling cutters and the like tools the cooling agent must be supplied in such way, by multiple nozzles or other device, as to keep the face of the cutter well covered, while at the same time it falls upon the chip at the point or line of removal. The latter requirement holds particularly in cutting with lathe and similar tools when a cooling agent is used. There can be no advantage in trying to force a stream under the chip and toward the cutting edge or point of the tool, as shown in the illustration, Fig. 196. The stream must be directed upon the chip just where it is being separated from the body of the piece, and, let it be repeated, in generous amount. The small streams customarily used are quite ineffective, except possibly in the case of very light cutting. It is necessary to deliver gallons of lubricant where it has been customary to deliver pints. The heavy streams serve another useful purpose in cases where the chips come off small or well broken up, in that they carry or float them out of the way. In drilling, for example, it is quite necessary that the stream of lubricant reach the bottom of the hole, not only to cool the lips of the drill, but to float up

the chips. In drilling tenacious material it is better to depend upon a feed sufficiently heavy to allow the chip to come out of the hole in one complete piece, if that be possible. This is especially desirable if the hole be deep. If it does not exceed twice or three times the diameter of the drill, mere flooding in oil will suffice. It is of course necessary in all cases to provide collection pans and suitable drainage.

**High-Speed Chip not Unique.**—In this connection it may be remarked that the chip cut by a high-speed tool differs in no essential respect from that cut by a carbon tool under similar conditions. There was at one time much discussion of this point, based seemingly upon certain superficial differences which arise from the greater amount of metal generally removed and the higher speed at which the work is customarily done.

## CHAPTER XVI.

### SPEEDS AND FEEDS, AND RELATED MATTERS.

**Variables Affecting Efficiency.**—The conditions under which metal cutting tools work are so various in different establishments, or, for the matter of that, in the same shop, that generalizations in respect to speeds and feeds are rather difficult, even when jobs are pretty well classified. Certain conditions unquestionably are fundamental; but in the main most of them vary to such an extent that confusion easily results from attempts to apply definite formulas, in working out standards or in applying them to specific operations. Mr. Taylor points out no less than twelve distinct variables affecting the efficiency of chip production, and indicates their relative importance by the ratios between the higher and the lower limits of speed as affected by each element within the ranges met with in ordinary machine shop practice, as follows:

1. The quality of the metal to be cut — its hardness or other qualities affecting the cutting speed. Proportion is as 1 in the case of semi-hardened steel or chilled iron, to 100 in the case of very soft low carbon steel.

2. Chemical composition of the tool and its treatment. Proportion is as 1 in tools made from tempered carbon steel, to 7 in the best high-speed steel. (This proportion may often be exceeded).

3. Thickness of the shaving, measured by the actual traverse. Proportion is as 1 with thickness of  $\frac{3}{16}$  inch, to  $3\frac{1}{2}$  with a thickness of  $\frac{1}{84}$  inch.

4. Shape or contour of the cutting edge of the tool, chiefly because of the influence it has upon the thickness of the chip. Proportion is as 1 in a threading tool, to 6 in a broad-nosed cutting tool.

5. Use or non-use of a cooling or lubricating agent. Proportion is as 1 for a tool running dry, to 1.41 for a tool cooled by a copious stream of water.

6. Depth of cut or the amount by which the piece is to be reduced at the place of taking the chip. Proportion is as 1 with  $\frac{1}{2}$  inch depth of cut, to 1.36 with  $\frac{1}{8}$  inch depth of cut.

7. Duration of the cut or time through which the tool must last without being re-ground. Proportion is as 1 when tool is to be re-ground every 90 minutes, to 1.207 when it is to be ground every 20 minutes.

8. Lip and clearance angles of the tool. Proportion 1 with lip angle 68 degrees, to 1.023 with angle of 61 degrees.

9. Stiffness of tool and work. Proportion 1 with tool chattering, to 1.15 when running smoothly.
10. Diameter of work.
11. Pressure upon the lip of the tool.
12. Possible speed and feed variations in the machine, and its pulling and feed power.

**Generalizations Necessary.**—The very fact, however, of such a multiplicity of factors makes it essential to arrive, if possible, at some generalizations, or at least some method of intelligently putting together the variables so as to harmonize them and to work for highest efficiency. The mere recital of experiences, perhaps useful in a way, serves small purpose except possibly to show the limits under a given set of conditions.

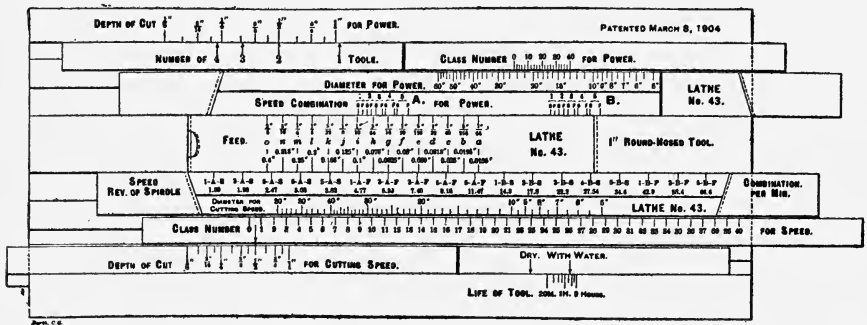

FIG. 197. Barth slide rule embodying the laws deduced by Taylor and his associates.

Thus there is little significance in a statement that a certain tool cut soft steel in a lathe at a rate of 200 feet per minute. But if it can be shown that under a given set of conditions susceptible of approximate duplication in a pretty well-defined group of jobs, a tool can be expected to do a certain amount of work, that is to say, can take such and such a cut at such a speed, then something is gained, something established which may be used as a basis for comparison for all jobs falling within the category so defined. Just such a series of laws or formulas Mr. Taylor and his associates succeeded in working out during the course of their investigations, formulas easily applied to the general run of jobs by the aid of a simple slide rule devised for the purpose.

**Elements Affecting Economies.**—The results accomplished through the use of the laws thus established, and the slide rule, have fully justified themselves. And while the work upon which these formulas are especially based is in the main heavy cutting, that is to say, the removal of relatively large quantities of metal from large pieces of stock, they and the tables derived from them are to a very considerable extent available for general use in connection with the ordinary jobs found in general manufacturing; and a systematic use of them is sure to give



surprising results. Reductions in labor cost of a half are not rare; and a considerable reduction in the number of workmen and of machines used is also to be expected in many cases. Such reductions will in large part depend, ordinarily, as well upon a number of other concomitants as upon the cutting speed. These are elsewhere considered, and it is desired here merely to direct attention to them as factors which affect

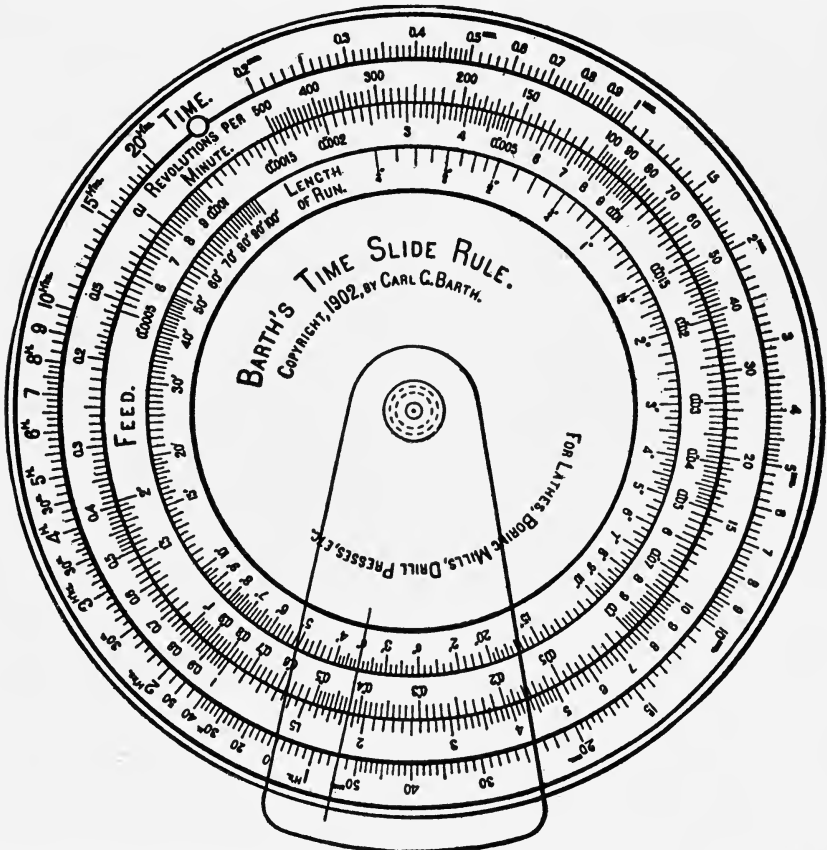

FIG. 198. Barth time slide rule. Used in connection with lathe slide rule (Fig. 197) to determine time required for a given feed, cut and speed.

Those especially interested in the use of the slide rules and the formulas developed for use in connection with them are referred to Mr. Taylor's "On the Art of Cutting Metals," and to Mr. Carl G. Barth's "Slide Rules for the Machine Shop as a part of the Taylor System of Management," published in Vol. 25, Transactions of the American Society of Mechanical Engineers.

the getting out of product and which, if not taken into consideration, may quite nullify any advantage arising from the higher cutting powers of the new tools. Such factors are the size of the piece worked upon, the facility for transporting and storing it within easy reach of the workman, the design of jigs and other holding or guiding devices to facilitate rapidity of handling, the proper grinding of tools, careful inspection of parts, and perhaps others.

**Number of Variables Reducible.**—The variables affecting the actual cutting, while numerous, can in the average shop be considerably reduced, and as a matter of fact are actually so in so far as the operations of any particular class are concerned. The depth of cut, for example, in nearly all cast-iron pieces will be about the same for all, unless there should be some unusual condition requiring a different. The standardization of tools eliminates the variables resulting from cutting angles and contour of cutting edges except in so far as it may be necessary to use different sizes or special tools. Likewise the composition and treatment of the tool becomes standardized under well-regulated management, and the amount of vibration in machine and tool is reduced to the minimum and thus also standardized, so to speak. The use or non-use of a cooling agent also will be definitely understood. The amount of pressure upon the tool is of so little influence on the cutting speed that it is negligible anyway. So that, outside of the factors which concern the powers of the machine, there remain ordinarily but five variants to take into consideration, namely, the quality of the metal being cut, the duration of the cut, the diameter of the piece (generally negligible) in lathe work, the feed, and the speed. In the engineering shop, as distinguished from the general manufacturing shop which duplicates parts in large numbers, of course the variables cannot be so readily standardized.

**Taylor Standard Speeds.**—The standard speeds worked out during the course of the Taylor investigations, given in Appendix F., as already indicated presume long and heavy cutting, conditions under which high-speed tools work at their highest efficiency. But as also pointed out, this class of jobs forms but a small proportion of those found in general manufacturing; and accordingly, for one reason or another, it is much of the time necessary to modify somewhat the standard speeds and cuts established for standard conditions and tools. Thus in a case where the cutting time is very brief relative to that for the whole operation, and the operator has all that he can possibly do to take care of the product anyway, a very high speed is not only unnecessary, but perhaps even undesirable. The gain in such case would probably be mainly through the saving in grindings. On the other hand there will be few cases, probably, where some speeding up is not only possible but desirable. The problem thus becomes so involved that the only safe way is to accept the standard speeds, and working from these, establish specific ones which shall be particularly suited to the cases in hand.

**Commercially Practicable Speeds.**—What must be aimed at, generally speaking, is the speediest removal of metal commercially practicable — the best speed, feed, and depth of cut, or speed and feed, if the cut is standard — at which the tool will work effectively and with due consideration of economical maintenance and the condition of the existing equipment; and all this without especial regard to the total amount

of metal removed. In order to the attainment of such an end it is necessary first to get away entirely from preconceived notions as to cuts and speeds, so as to be governed by the information available through the experiences of others and through data collected in the shop as experience is gained in the applications of the new tools.

**How Conditions Vary.**—The great variations in different shops, not only in respect to equipment but also to the material worked upon, preclude either the tables here given, or the standard cutting speeds from which the Taylor formulas were worked out, being unreservedly accepted. Indeed, they are for the most part entirely too fast for ordinary practice. The speed curves here illustrated, Fig. 199, are also based on experience,

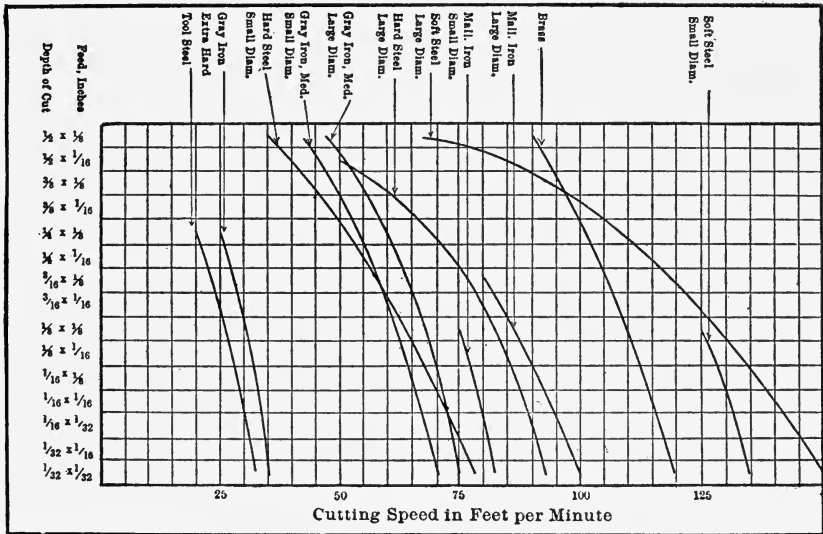

*The Engineering Magazine*

FIG. 199. Curves used in one establishment for determining speeds suitable for various feeds and depths of cut, in turning operations.

For milling operations add 50 per cent to the appropriate speeds indicated above, taking care to apply the selected speeds to feeds for which they are suited. For boring subtract 10 to 40 per cent, and for drilling and reaming, see table of drill speeds and feeds at page 249. The "small diameters" refer to those under 5 inches.

and have been in satisfactory use as a basis for the cutting operations in a large factory for a number of years. In another plant the conditions might be quite different, and a different set of standard speeds might have to be worked out. One of the important things in connection with a program of maximum production, therefore, is a careful investigation into the nature of the material used and the establishment of a set of standard speeds suited to those conditions.

**Speed Meter and Stop Watch.**—In the investigations and demonstrations connected with the determination of such standards, a stop watch

and a speed meter are absolutely essential. A form of the latter is available by which the speed in feet per minute can be read off directly from the indicator when the contact wheel rolls upon the moving surface, whether cylindrical or plane. The stop watch is best of the kind with two hands, one of which can be stopped independently of the other. These, in the hands of a competent person charged with the determination of operation time for jobs and able to demonstrate unequivocally that

the work can be done in the time set, will work many surprises. It is desirable of course also that some way be provided whereby the workman himself can know certainly if he is using the correct speed—that is, in such jobs as are not standardized. In such, the proper combination once given for obtaining the required speed, there should be no occasion for changing so long as the workman is on that particular operation.

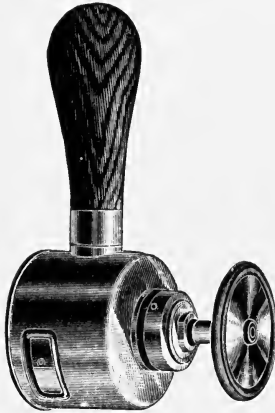
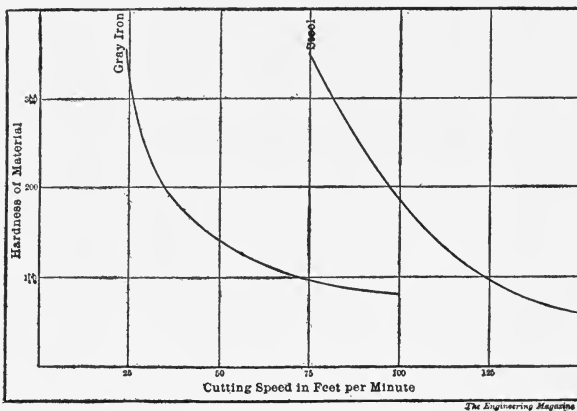

FIG. 200. Warner cut meter, for direct reading of speeds. Courtesy of Warner Instrument Company.

**Nature of Variables in Metal Cutting.**—The variables affecting cutting speeds, to be considered in working out such standards, have been already indicated. Mr. Taylor has in his paper considered so fully the influence of each, and the reasons involved, that it does not seem

either necessary or desirable here to do more than mention briefly the nature of those influences.



*The Engineering Magazine*

FIG. 201. Curves showing the effect of increasing hardness in material upon the speed permissible to a tool, for efficient service.

100 is taken as the standard for moderately soft material, and 400 as about the limit of hardness as usually handled in manufacturing.

**Quality of the Metal.**—By the quality of the metal is meant its relative hardness or softness and other characteristics which differentiate cast iron from steel and other metals, and steels of varying degrees of tough-

ness from each other. The harder the material, in general, the slower the possible speed (note the curves in Fig. 201), this latter varying from 10 to 12 feet per minute in the case of chilled iron, to, say, a possible 500 feet in the case of very mild steel. The latter speed, it should be mentioned, is possible only under most favorable conditions and with a very fine feed and cut, and is scarcely practicable, commercially. Under commercial conditions the quality of material varies so much, even in the same shop, and the variations usually are so difficult to detect before the material actually is put under cut in the machine, that little can be done ordinarily in the way of generalization. Castings, for example, which one day come soft and easily machined, another day may come exceedingly hard. Of course in a plant producing its own material, such differences can be reduced to a minimum, if not eliminated. Usually, however, because of them, it is desirable to allow some latitude to the workman in respect to this matter, so that in general it may be necessary to fix a standard speed somewhat lower than could be advantageously used regularly if the material came through of a uniform softness.

**Quality of the Tool.**—The quality of the tool involves, of course, its composition, which must be adapted to the special use or be of a good general all-round excellence, and the proper treatment of it in hardening. Evidently a high-grade steel should be selected, and the tools treated uniformly for the same service. This will eliminate all need for considering this as a variable.

**Use of Cooling Agent.**—The use of a cooling agent will permit a considerable increase in speeds, as previously stated, ranging from 15 per cent or so in the case of cast iron, to 35 or 40 per cent in that of steel. It is advisable to calculate upon the use of a cooling agent wherever feasible — that is, wherever the cost and annoyance would not overbalance the gain.

**Length of Cutting Run.**—In general work the cuts are short, and thus allow the tool to cool off between times. The time during which such

TABLE IX.

Showing how much a high-speed tool must be slowed down in cutting speed in order to have it last a long time without regrinding.

Given the proper cutting speed for a cut lasting	to find the speed for a cut lasting	divide by	or multiply by
20 minutes	40 minutes	1.09	0.92
40 minutes	80 minutes	1.09	0.92
20 minutes	80 minutes	1.19	0.84
40 minutes	20 minutes	0.92	1.09
80 minutes	40 minutes	0.92	1.09
80 minutes	20 minutes	0.84	1.19

Adapted from Taylor.

a tool will run without re-grinding, therefore, is likely to be somewhat longer than if it cut continuously. The establishment of a standard time after which tools in general should be ground is difficult except when they are run continuously at maximum speed, and for the most part it will be impossible to lay down hard and fast rules for this factor. In the main it is safe to leave this to the judgment of the workman. Especially if he is working by the piece or for a premium he will quickly learn to note the condition of the cutting edge and to take care that the tool is ground as often as necessary — not grinding the tool himself, be it remembered, but merely setting up a sharp one which he will have at hand for that purpose.

**Clearance and Cutting Angles.**—No important improvement seems to have been made upon the Taylor standard tools (though it is well to bear in mind what is said elsewhere in reference to the Hartness type of tool), so that in the matter of clearance and cutting angles, as well as contour of cutting edge, it is well to undertake few changes, if any, except perhaps in the case of jobs requiring tools of special form.

**Effect of Chatter.**—The possibility of any considerable amount of vibration will reduce the attainable cutting speed by something like 15 per cent. The purpose of course should be to eliminate this item as far as possible through the use of machines suited to the work and not worn beyond hope. In the same connection the possible pulling and feeding power of the machine must be considered. If inadequate, evidently the speed, and more than likely also the feed, will have to be reduced to meet the condition. The use of a steady rest is advised for all work of any considerable length.

**Depth of Cut Problems.**—The depth of cut will, for the most part, be dependent upon the class of work done in the shop, and as pointed out in another place, may need to be increased, a suitable allowance in the size of the piece being made in this case, so as to overcome chatter or riding of the tool.

**Factors Affecting Feed or Traverse.**—Traverse or feed will be governed to some extent by the possibilities inherent in the machine, but a good deal also by the surface required. The limitations are rather narrow, usually, in a given shop. A round-nosed tool, such as will probably be used for most operations, when cutting with a heavy feed leaves a correspondingly rough surface. And since probably most of the work of the kind now under consideration must be done with a single cut, it is necessary to select a feed or traverse which will leave a sufficiently smooth surface. Anywhere from one-sixteenth to one-eighth inch feed will do this, unless the tool be a very small one. Obviously the larger the curve of the cutting edge, the coarser the feed may be in the case of lathe and similar tools. A variation so great as this would seem to make a considerable difference in the possible cutting speed; for this depends

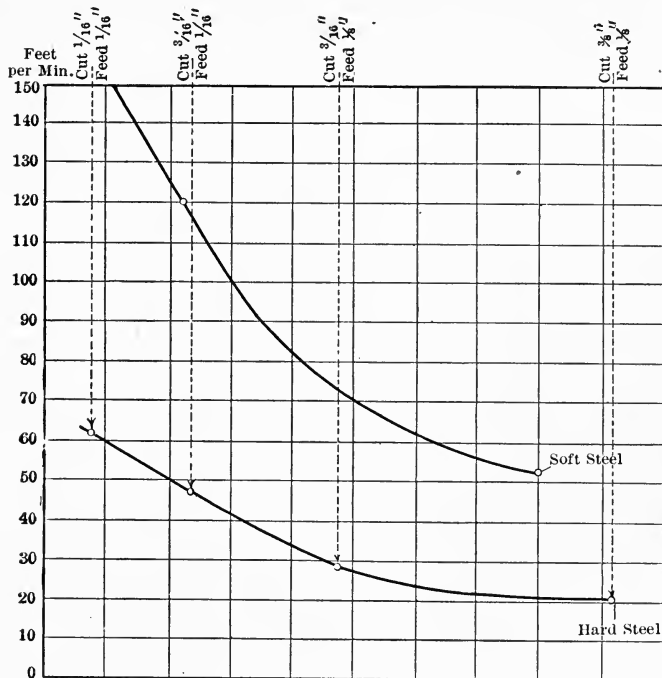

FIG. 202. Relation of economical speed to cut and feed. Steel in steel cutting.

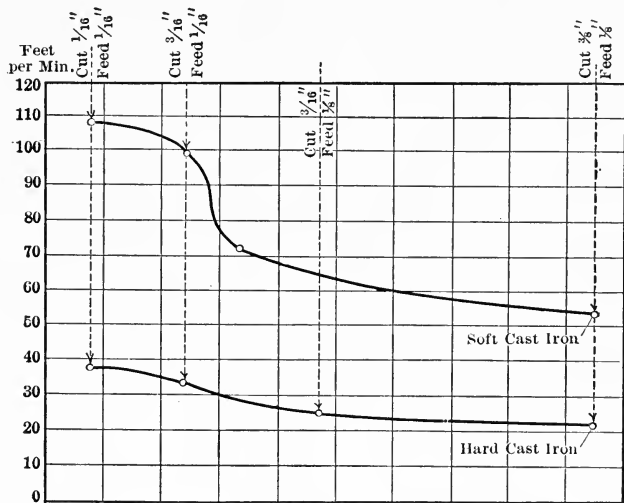

FIG. 203. Relation of economical speed to cut and feed in cutting cast iron. Both figures adapted from speed sheets made by Samuel Osborn & Co., Ltd.

upon the feed and cut to a very important extent, as already seen. In fact it would, under conditions allowing maximum effects, make a reduction of a fourth to a third in the speed. As a matter of actual practice, however, under the conditions here considered, the speeds will rarely, if ever, be the maximum possible, so that a variation of the magnitude indicated is of no particular consequence — though of course the contingency of a possible necessity for changing the speed must not be overlooked. Obviously the power available must also be considered. In milling operations the table traverse or feed has in ordinary practice been ridiculously small, just as it has in the case of drilling and similar operations; though until recently it has been not far below the possibilities of the machines in use. The real need for giving each cutting blade enough work to do to keep it in the metal rather than riding over it at times, seems to have been little regarded. It is quite as necessary for the blade of a milling cutter to get a good “hold,” so to speak, upon its work, as it is in the case of a lathe or similar single cutter tool. The traverse of course is interdependent with the number of cutting blades and the speed of cutting. About 0.01 inch per tooth per revolution is correct for most work, though with large cutters and plenty of chip clearance considerably more is allowable.

**Phenomenal Results.**—A tool steel vendor reports having obtained a speed of 232 feet per minute,  $\frac{1}{4}$  inch cut and  $\frac{1}{8}$  inch feed, on cast iron; a large user of high-speed steels mentions that he has seen a tool running for a full hour, on cast iron, at the rate of 125 feet per minute, removing scale; and another cutting steel at the rate of 270 feet per minute for nearly 30 hours at a stretch. Indeed it has been reported that a tool has cut steel for some time at the rate of 500 feet per minute. Other phenomenal performances also have been mentioned elsewhere. Now all these, and similar performances, are very interesting as showing something of the powers of the new tools. But they are not commercially practicable. In turning castings, as they come ordinarily, 65 to 70 feet per minute is as high a speed, with usual feeds, as can be maintained continuously without too frequent grindings of the tool. Light cuts may be taken up to 100 feet. Making allowance for variations in hardness and the powers of the machines likely to be used, however, 50 feet is more likely to be satisfactory as a basis to work from. This is easily double what we have been accustomed to under the old conditions. Light finishing cuts have been taken with a satisfactory degree of accuracy as rapidly as 75 to 85 feet per minute, though something rather lower will usually be found better on the whole. At these rates the speeds for soft, medium, and hard irons would be respectively about 90, 50, and 25 feet; and for moderately heavy cuts about 60, 30, and 20 feet. These speeds of course will be modified according to the size of the tool, the precise feed and depth of cut, and the rest of the variable conditions. Working on



pieces of large diameter, for example, the speeds may be increased 10 to 15 per cent. This is not only because in such pieces the direction of the cut changes less rapidly, but because even in sand molds small pieces have a tendency to chill more or less, and the cut in work of this sort also being customarily lighter than on heavy pieces, the tool is actually working on iron averaging a good bit harder than if cutting on a large piece.

**Turning Chilled Iron.**—Chilled iron can be turned at anywhere between 3 and 10 or 12 feet per minute. The rate of cutting is of small consequence, since most of the time is used in changing the tool anyway. A tool that will hold up at 3 feet will be almost certain to do quite as well at three or four times that speed. It should be remarked in passing that the turning of chilled rolls is accomplished by the use of tools of special design, ordinary tools being of little use generally. The common method is to use a square section of steel for the tool, grinding the longitudinal edges to sharp right angles for cutting edges, and rigidly wedging this unique cutter against the surface of the roll. The tool is not traversed, but its position is changed each time it has finished a section of the roll. For cutting grooves and spirals, the end of the section instead of the longitudinal edge is forced into the iron.

**Speeds in Steel Turning.**—In steel cutting, speeds have been attained very much higher than on cast iron. The reasons for this have been already assigned. On mild steel light cuts at 80 or 90 feet are not infrequently taken, and 100 feet or even more are sometimes used. Taylor's tables allow 128 feet per minute on soft steel with a  $\frac{3}{4}$  inch tool, cut  $\frac{1}{8} \times \frac{1}{8}$  inch. These are not usually practicable commercially except under conditions allowing maximum effect. Roughing cuts, say about  $\frac{3}{8} \times \frac{3}{32}$  inch, with a 1-inch tool, can be taken at a maximum of about 100 feet per minute on mild steel, while 70 to 75 feet is considered good practice. Medium steel, say 3 to 5 point carbon, under customary conditions, can be cut at approximately 70 and 50 feet for light and heavy cuts respectively, though rather less is likely to be more satisfactory; while hard steel, say 7 point carbon and above, is not usually cut faster than about 35 feet in light cuts (say about  $\frac{1}{8} \times \frac{1}{8}$  inch) and 25 feet in roughing.

**Cutting Malleable Castings.**—In malleable castings 80 feet is about all that can be expected on small pieces, where light cuts are taken. Heavy cuts, as already shown, are to be avoided in castings of this kind. On large pieces the speed may under favorable conditions be made as high as 90 or even 100 feet per minute. If a cut as deep as  $\frac{1}{4}$  inch be taken for any reason, the speed will be nearly half that indicated.

**Brass, Aluminum, and Alloy Steels.**—Speeds for brass and other soft materials will be somewhat greater than those suitable in cutting steel. The alloy steels, like chrome and nickel steel, now coming into large use

for machinery parts, vary so greatly in characteristics that it is quite impossible to lay down at present any general statement as to permissible cutting speeds. Aluminum can be worked at about four times the speed and double the feed possible with mild steel.

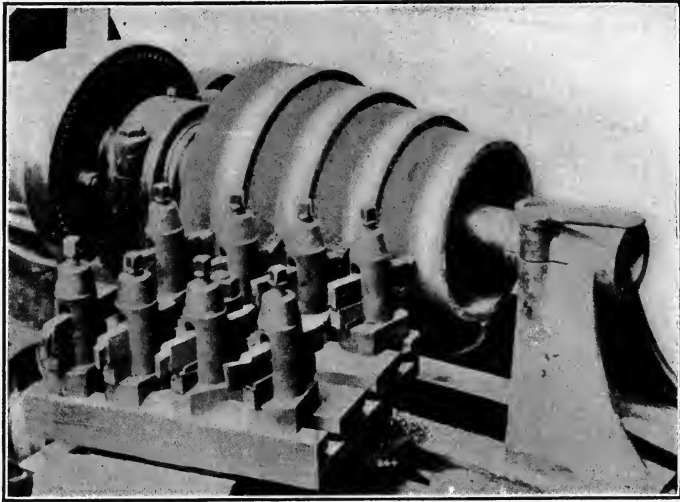

FIG. 204. Use of multiple tools in turning cast-iron cone pulleys. Speed on largest step, 120 feet per minute.

**Use of Multiple Tools.**—The use of double or multiple tools allows a distinct gain in speed in turning operations. The interrelation of speed and feed makes it necessary to reduce the former when the latter is

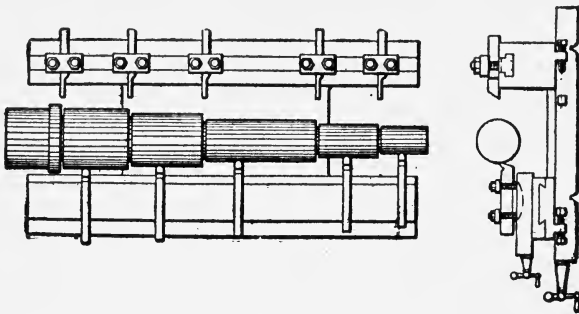

FIG. 205. Lathe fitted for rapid roughing and rapid finishing.

increased. A single tool taking a chip  $\frac{3}{8}$  inch wide (traverse  $\frac{3}{8}$  inch per revolution) must run considerably slower than two tools, each feeding at  $\frac{3}{16}$  inch per revolution. Doubtless there is some difference in the amount of power absorbed; but this is a matter of relative insignificance. The advantage of using multiple tools in long cuts has never been recog-

nized as it should be. The advantage under the new conditions should be evident enough to warrant a large use of them, especially in operations involving the removal of large quantities of metal.

**Reduction of Speeds in Certain Operations.**—It has doubtless been observed that the discussion of speeds and feeds thus far has been confined for the most part to turning operations. With the possible exception of milling, where the cutting edges work intermittently and are for

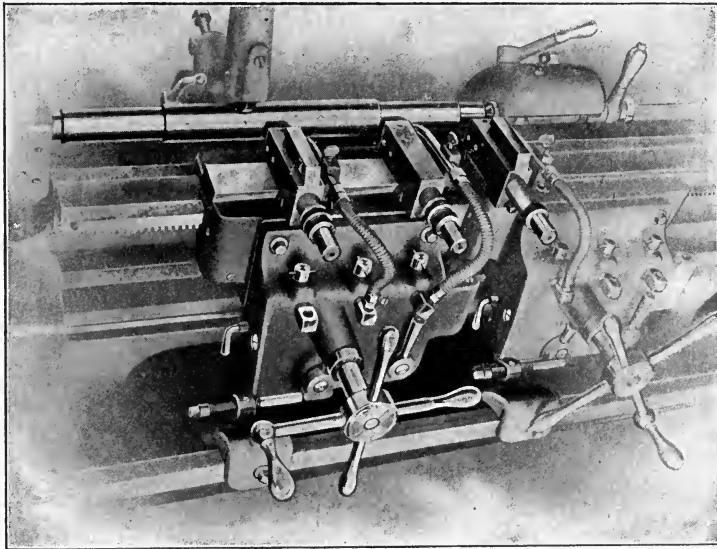

FIG. 206. Multiple tool carriage, as applied to "Lo-Swing" lathe. See Fig. 207 for data as to this particular job.

the greater part of the time exposed to the cooling effect of the air or a cooling agent, these permit greater speed than any others in metal cutting. It is therefore necessary, in setting standard speeds for other kinds of work, to make allowance for the variations in conditions — variations not provided for in most tables of cutting speeds now available. Internal cutting with a boring bar, for instance, must be considerably slower than external turning of the same diameter. In outside cutting the tool may have ample clearance, or it may even ride upon the finished flank — a condition impossible in the case of internal cutting. Furthermore, in order to secure a sufficient clearance it is necessary to give the cutting edge a more acute angle, or else to give it less rake than that of the corresponding standard tool. Either condition involves a slower cutting speed, the reduction being something like 10 to 15 per cent if the bar is exceedingly rigid. If not, the loss is more likely to be nearer 40 per cent.

**As to Drilling.**—Something of the same sort is true of rose reamers, and of twist drills also, to some extent. In drilling, little attention need be paid to this point, however, since but few machines are now in use which

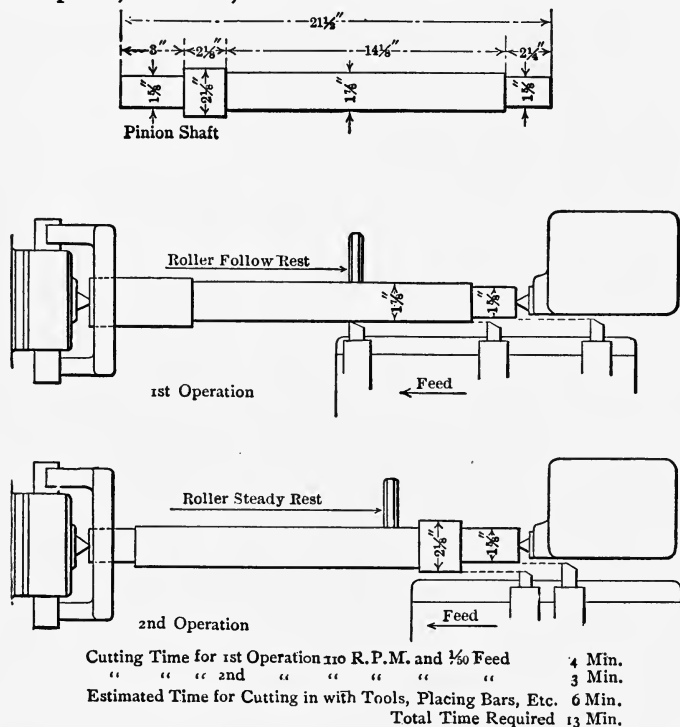

FIG. 207. Performance in rapid reduction, in machine building, by use of multiple tools. Courtesy of Fitchburg Machine Works.

will effectively speed a drill to the limit of efficiency. The most satisfactory practice in drilling average cast iron allows a peripheral speed of about 65 to 70 feet per minute, though under exceptional conditions still higher can be used to advantage. The feed per lip per revolution may vary from 0.008 to 0.02 inch, according to the size of the drill and the conditions, with respect to rigidity and powering of the machine and the cutting angle, of the drill. It must in any case be heavy enough to permit the drill to bring up a good chip; otherwise there is likelihood of the latter being pulverized and then acting as an abrasive to grind away the cutting edges. As with lathe tools working with exceedingly fine cuts, a drill will stand a higher speed when taking a moderately heavy cut than when taking almost none. The frequent breakage of drills, occurring just as the point emerges from the metal and commonly ascribed to high speed or excessive feed, really is due to spring or slack in the machine; and the remedy is not in reducing the speed or feed, but in strengthening the machine. In the great majority of jobs as at present

TABLE X. SPEEDS AND FEEDS FOR DRILLS.

Size of Drill.	Revolutions per Minute.					Feed per Revolution.
	Steel.	Mall.	Cast.	Brass.	Tool Steel.	
$\frac{1}{16}$ .....	4015	4620	4820	7650	1970	.001-.002
$\frac{1}{8}$ .....	1850	1925	2220	3515	906	.002-.004
$\frac{3}{16}$ .....	1380	1610	1650	2810	675	.003-.006
$\frac{1}{4}$ .....	1040	1190	1250	1970	506	.004-.008
$\frac{5}{16}$ .....	855	982	1028	1620	420	.004-.008
$\frac{3}{8}$ .....	782	806	836	1330	342	.005-.010
$\frac{7}{16}$ .....	604	688	720	1140	295	.005-.010
$\frac{1}{2}$ .....	527	605	632	1003	258	.008-.016
$\frac{3}{4}$ .....	425	488	512	807	210	.008-.016
$\frac{7}{8}$ .....	347	410	420	666	173	.008-.016
1.....	300	346	360	568	146	.008-.016
1.....	260	298	312	495	128	.010-.020
$1\frac{1}{8}$ .....	228	264	276	436	112	.010-.020
$1\frac{1}{4}$ .....	215	248	260	410	106	.010-.020
$1\frac{3}{8}$ .....	200	230	238	380	98	.010-.020
$1\frac{1}{2}$ .....	178	205	216	342	92	.010-.020
$1\frac{3}{4}$ .....	154	173	180	290	73	.010-.020
2.....	130	150	156	246	64	.010-.020

This table is based on a peripheral speed of 60 to 65 feet per minute in soft steel, in the medium diameters. As the diameters decrease, the peripheral speed is increased, this being good practice. If run without lubricant, the speeds should be reduced 15 to 20 per cent. The feed is preferably the lighter one given, though under good conditions the higher gives good results. For rose reamers, and for threading dies and taps, about half the speeds indicated are to be used.

done, the lack of positive feeding device on the machine makes the feed a matter of judgment on the part of the operator — or, more likely, a matter of his strength — with the consequence that efficiency is lost. In drilling holes of small diameter the feed is all but certain to be too heavy, and the reverse in large sizes. It would seem more than desirable that all machines be fitted up with positive feed devices to insure the best results.

**Speeds and Feeds for Rose Reamers.**—Twist drills have ample rake at the cutting edge, and therefore can be run considerably faster than reamers, which latter all but invariably have no front rake to the cutting blades. About half the speed allowed to drills is usually satisfactory with reamers and similar internal cutters. In using the table of speeds for drills to determine reamer feeds it must be remembered that the feeds given are for two-lipped drills, whence it is necessary, in order to get the correct feed per revolution for a reamer, to take half the product of the feed given for the specified diameter by the number of flutes or lips; or, putting it another way,  $\frac{F \times L}{2}$  = required feed per revolution, where  $F$  and  $L$  respectively are the feed stated in the table and the number of cutting lips. Concretely this would give, in the case of a 2-inch six-fluted

reamer, cutting cast iron, the following: Feed per revolution =  $\frac{0.01 \times 6}{2}$   
= 0.03 inch. It is not advisable to use on reamers the higher feeds given for drills. This matter is, under ordinary conditions, of greater importance than in the case of drills, because reamers customarily are used on machines provided with positive feed, and hence the amount of feed can be regulated as it should be.

**Milling Operations.**—The highest practicable speeds in metal cutting are obtained in milling operations, though the feeds have until recently been absurdly slight. The intermittent nature of the cut, allowing the teeth or blades to cool between times, has something to do with the higher speeds permissible. Compared with drilling, the gain is something like 50 per cent. The peripheral speed, at a depth of cut and table traverse per tooth per revolution of  $\frac{1}{8}$  inch and 0.01 inch respectively, which may be taken as a maximum when working on average cast iron, is about 90 feet per minute, though considerably higher speeds have been maintained. The customary speeds are rather lower, especially if no lubricant be used. This basis is rather high for a machine such as is ordinarily in use, and is likely to stall it. With powerful machine and properly designed cutter, however, it is none too high, and is by no means remarkable compared with some everyday performances like cutting nickel-chrome armor plate at 75 feet and nickel steel at 80 feet. It must be said, however, that cutting like this last mentioned could not be done except on machines thoroughly adapted to the work. In taking finishing cuts it is customary to use speeds considerably slower than those indicated.

Of course, as in the case of other tools, allowance has to be made for the kind of material worked upon, in the determination of practicable peripheral speeds. Those found to be generally efficient and productive are: Cast iron, medium, from 90 feet per minute down; malleable, 85; mild steel, 75; tool steel, 35; brass, 140, aluminum, 500 or more. The table traverse in the case of brass and aluminum will of course be advanced to correspond with the high speed. Speeds for the several grades of cast iron and steel can be derived from the tables given for turning operations, the figures above being taken as starting points.

**Taps and Threading Dies.**—Taps and threading dies may be run as fast as the material can be taken care of; and this will rarely exceed half the speed indicated in the table of speeds and feeds for drills. On some kinds of material even less than half is possible. Even so, however, there still is usually a considerable gain over the output of carbon steel tools.

**Planer and Shaper Speeds.**—As to planer and shaper work, and other cutting of like nature, it is necessary to point out only that the tools will carry all the speed, and in general all the cut, that the machine in use may be capable of pulling. Some recent performances indicate the

possibility of an 80 feet per minute planer cut, though this does not seem to have been accomplished in a commercial way. Sixty feet, however, has been carried as a regular performance; and this may for the present be accepted as a maximum record in regular work, while 50 feet, with a high-speed return, is about as much as can be expected on any reciprocating machine — and this only on one of strictly modern design. Older types of machine cannot give much more than half as high a speed without much racking and burning up of belts.

## CHAPTER XVII.

### FUNDAMENTAL CONSIDERATIONS IN THE DESIGN OF THE NEW TOOLS.

**Factors in Efficiency.**—The prime motive in machine and tool design obviously is efficiency. One productive apparatus is preferred above another because it turns out work more economically while still not sacrificing the accuracy or quality requisite. What is called efficiency, then, is usually considered to mean a maximum production of satisfactory quality at minimum cost. In most instances the chief element in cost is labor: which is to say, time. Wherefore it is often assumed that the tool or machine which works most rapidly is of necessity the most efficient. Nevertheless, there are other considerations which are not infrequently quite as important as time, or which at any rate affect the time of production to a very great extent. The proper hardening and tempering of a high-speed tool, for example, has been previously mentioned. Unless given the treatment suited to the required service, the very best of high-speed steel will fail to do efficient work. So also the machine in which, and the material upon which the tool works, both affect its relative efficiency. A further important factor, in the past very little regarded, is the design and shape of the tool and the nature of its cutting edge — when it has one.

**Heavy Stock for High-Speed Tools.**—The need for greater cross-section in high-speed tools is referred to elsewhere. The steel itself is much stronger than carbon steel, and is therefore better able to withstand the stresses and shocks incident to their work. The increased strength, however, is not nearly in proportion to the increase in the stresses involved in the greater feeds or speeds or both, in the case of cutting tools. If properly supported, a section from one-fourth to one-half greater than that customary in carbon tools is generally sufficient allowance for lathe tools of standard form and others similarly supported. In special or intricate shapes of course the allowance would better be somewhat greater, as also where the requirements may be especially exacting. If run at speeds not much greater than those customary with the old tools, and without much heavier cuts, of course there need be no increase in cross-section at all. All forms of these tools with slender necks or much side bend are to be avoided, since they tend to spring and twist under the heavy work, and are almost sure to chatter even under the most favorable conditions.



**Special and Oblong Sections.**—Special sections have been rolled, resembling I bar and other structural forms, intended to economize metal and afford greater strength in proportion to the weight than the rectangular section commonly used. Any advantage such sections may have is confined to tools made directly from the bar merely by grinding the required nose, these forms not being well adapted to forging — though they are sometimes slightly bent. It has been shown that while a very dull tool may at times require as much power to feed it as to drive, under normal conditions the side pressure is generally not more than 20 per cent of the down pressure, and usually is considerably less. The longitudinal diameter of a tool stock, therefore, can well be less than the vertical, though the amount of difference should not be great enough to allow a tendency to spring sidewise under abnormal conditions or to turn in the post or holder. The happy medium in practice appears to be, as recommended by Taylor, about  $1\frac{1}{2}$  vertical to 1 longitudinal unit. The length obviously should be such as to permit proper fastening in the post or holder, and also to allow re-fettling a suitable number of times. The length adopted by Taylor is approximately: Length =  $14 \times$  Width + 4 inches.

**Contour of Cutting Edge.**—Chattering, as explained elsewhere, depends upon a number of things; and one of these, assuming that the

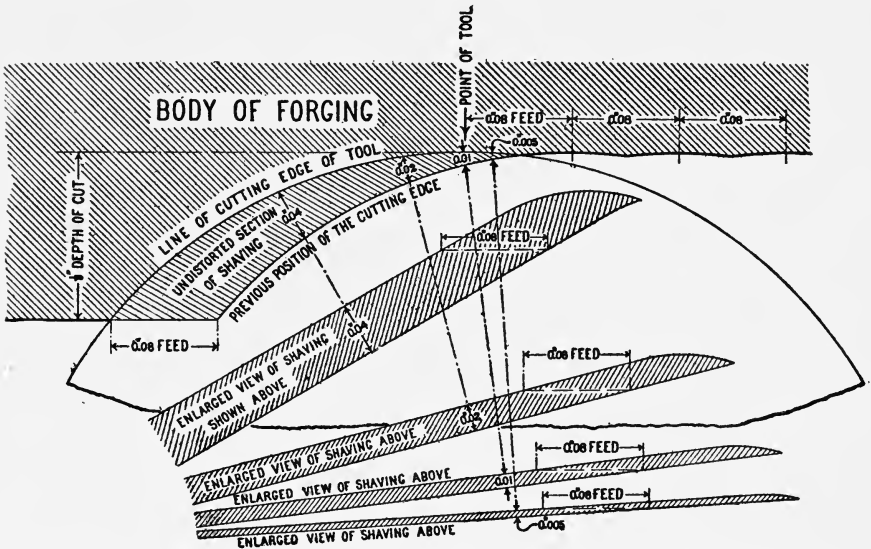

FIG. 208. Analysis of shaving, showing varying thickness at different points, thus tending to avoid chatter while at the same time minimizing work at the point or part taking the finishing cut.

tool is of such form and stiffness as not to spring under pressure, is the lack of correct angle and outline of the cutting edge. The experiments of Dr. Nicholson have shown that no matter how rigidly tool, machine, and

work are brought together, the cutting of a shaving or chip is accompanied by a more or less regular variation in the pressure upon the lip of the tool. The thinner the shaving, the shorter the wave-lengths corresponding to the variations in pressure. Evidently, then, if the thickness of a particular cut is uniform, that is, if the cutting edge of the tool is straight, there will be a tendency for the waves of pressure variation to emphasize any vibration in the tool, work, or machine, and thus produce chattering and consequently a badly finished surface. If the tool has, however, a curved cutting edge, so that the thickness of the chip varies (note Figure 208), especially if it varies from nothing at one side to the maximum at the other, the tendency will be for the various waves of pressure to counteract and nullify each other instead of emphasizing other tendencies just mentioned.

There are other reasons also why a curved cutting edge is preferable to a straight one in heavy and rapid cutting, if not in all cases, the most important of which Mr. Taylor has shown to be that it allows that

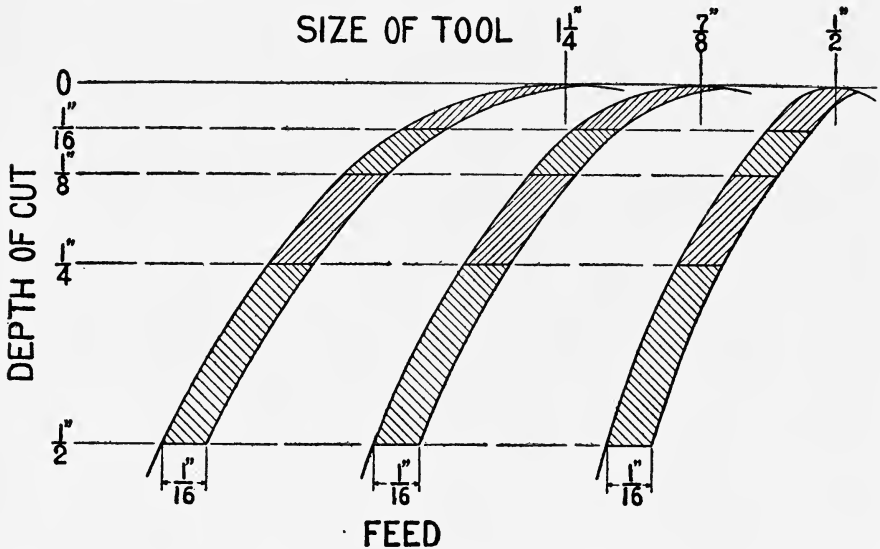

FIG. 209. Relation of size of tool (breadth of cutting nose) to thickness of chip at point of tool and therefore to maximum cutting speed. Limitation of feed (in respect to smoothness of finish) by decreasing size of tool is also shown. The relative thinness of the shaving taken by the larger tool is especially noticeable at the shallower cuts. After Taylor.

portion of the tool taking the finishing part of the cut to make a very thin chip. This part of the cutting edge under these conditions is less affected than that taking the heavy part of the cut, and continues sharp and in good condition for leaving a clean finish even after the rest of the cutting edge has become damaged.

**Broad-Nosed Tools.**—Mr. Taylor points out also that the amount of the curve has much to do with the effectiveness of the tool, showing that

curved tools with broad noses would be best, but for the tendency to chatter. The amount of curve to be given a standard tool is affected

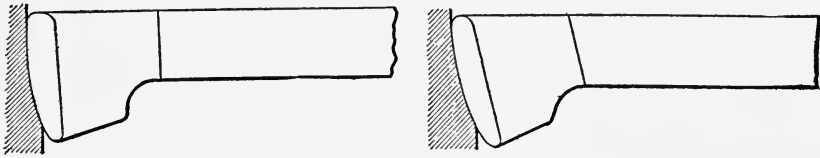

FIG. 210. Examples of Taylor broad-nosed tool.

by several conditions besides this tendency in broad-nosed tools to chatter, among them these: the size of the lathe and of the work to be turned, the depth of cut required, the amount of feed permissible, the speed possibilities, the smoothness of finish (relative amount of absence of ridges and furrows) required, the nature and resistance of the material cut, and any special conditions that may happen to be involved in particular cases. The maintenance of standard tools, in the ordinary shop, in sufficient variety to meet with highest efficiency all the possible combinations or conditions is manifestly impossible, even were it not necessary to sacrifice efficiency in one particular in order to more than balance up through some compensating modification in design.

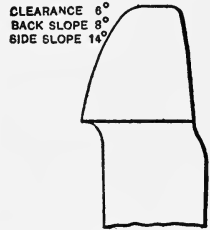

FIG. 211. Taylor standard tool for heavy feeds.

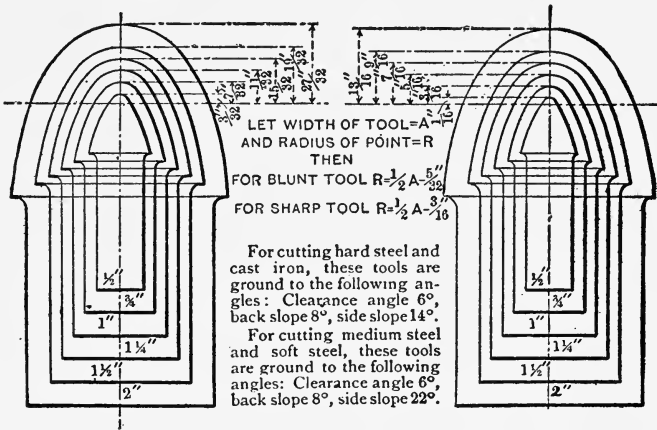

FIG. 212. Outline of cutting edge, Taylor standard round-nose tool.

**Standard Angles for Cutting Tools.**—The matter of lip angle (for definitions of terms used in connection with lathe tools see Fig. 213), for instance, while not of the degree of importance sometimes attached to it, has some influence upon the permissible cutting speed and the excellence of the work done, and a very considerable influence upon the

lasting quality of the cutting edge and the stresses imposed upon tool and machine. The clearance angle, from the need for the greatest possible support of the cutting edge, must be small, say about 6 degrees, as in the Taylor standard tools; while not yet so small as to prevent the

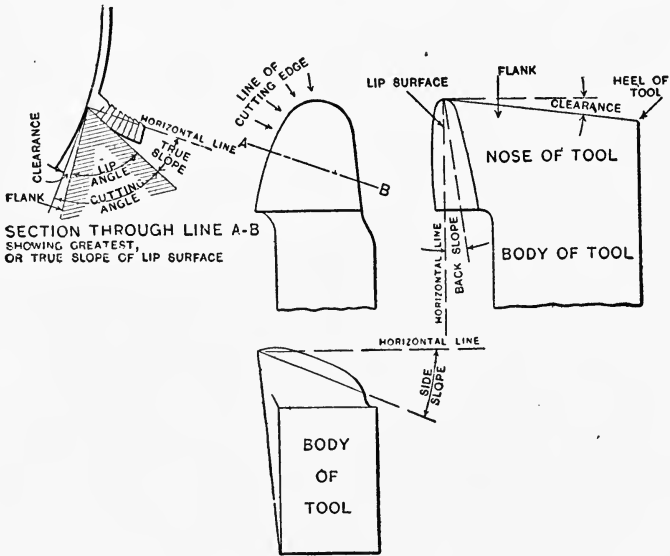

Fig. 213. Key to terms used in connection with lathe tools. From Taylor.

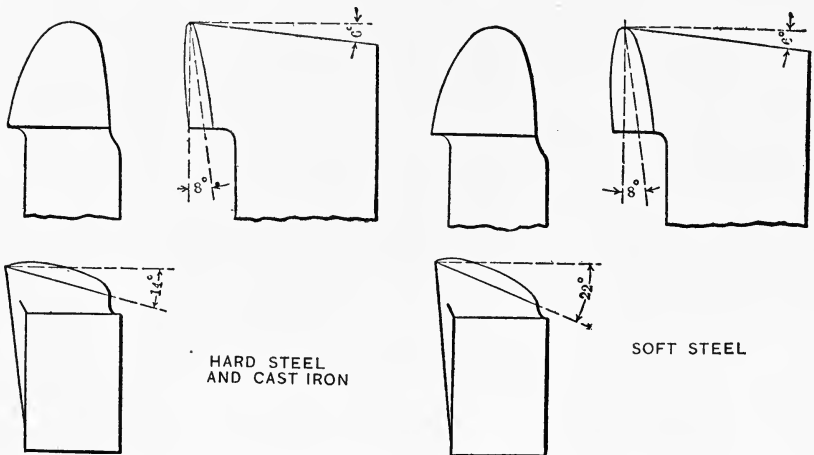

Fig. 214. Angles for cutting cast iron and hard steel compared with those for work in soft steel.

tool being readily fed into the work and to cause the flank of the tool to rub too much against the finished work. The lip angle of a tool will depend in a considerable degree upon the work it is to do. A small angle reduces the pressure upon the tool and perhaps allows some increase in speed; but other considerations, chiefly the necessity for having

a sufficiency of metal at the cutting edge to carry away the heat generated, and at the same time stand up to the work without crumbling, indicate a rather obtuse angle. The harder the metal being cut, the more blunt the cutting angle should be, the general rule being that the angle should be just as sharp as it may be without crumbling or spalling so rapidly as to impair the efficiency of the tool. The angles recommended by Taylor for the several typical classes of work ordinarily found in a shop; are given as follows:

Cast iron and harder steels (say 0.45 carbon and up), lip angle 68 degrees; clearance 6 degrees; back slope 8 degrees; and side slope 14 degrees.

Softer steels, lip angle 61 degrees; clearance angle 6 degrees; back slope 8 degrees; side slope 22 degrees.

For cutting chilled iron, 86 to 90 degrees lip angle.

Tire steel, and similar hard steels, lip angle 74 degrees; clearance angle 6 degrees; back slope 5 degrees; side slope 9 degrees.

Extremely soft steels (say 0.10 to 0.15 carbon), lip angle about 61 degrees, and perhaps less.

**Relation of Side and Back Slope.**—It is to be noted that the side slope recommended in these tools is considerably greater than the back slope, and varies also considerably from the angles heretofore customarily employed. The relatively steep side slope allows the tool to be much more frequently ground without weakening it, allows the chip to slide off in a line avoiding the tool post or holder, helps to correct the tendency of the tool to side deflection by throwing the pressure line within the base of the tool, and reduces the feed pressure. The greater bluntness in tools for cutting soft cast iron, compared with those used in cutting soft steel, is also noteworthy.<sup>1</sup>

**Hartness Type of Lathe Tool.**—Excellent results are obtained in many shops through the use of lathe tools of an entirely different type from those just described, cutting the metal in a way essentially different. In these tools, designed, it seems, by Mr. James Hartness in connection with his Lo-Swing lathe, there is no clearance, no forging, and the cutting angles may be of almost any degree of acuteness, in most cases much smaller than is customary. The cut is taken straight sidewise, the tool feeding along the periphery of the rotating work, and slicing off a band of a depth and thickness corresponding to the feed and depth of cut.

<sup>1</sup> Space does not permit here a discussion of the various experiments and experiences furnishing the reasons for the standards (those recommended and used by Taylor as standard cutting tools) given above. Any one caring to pursue the subject further will find much of interest in Mr. Taylor's address or report "On the Art of Cutting Metals," already mentioned. Another paper of very great interest, by Mr. James Hartness, considering the nature, cutting angles, and utility of the type of tools referred to in the following paragraph, was read before the same society at the 1908 meeting.

The ribbon chip is removed at the front (that is, by the edge of the tool) by real cutting, the nose of the tool being forced into the metal and wedging it away from the main mass; while at the finished surface of the work the action is comparable to that of shearing, leaving, however, a

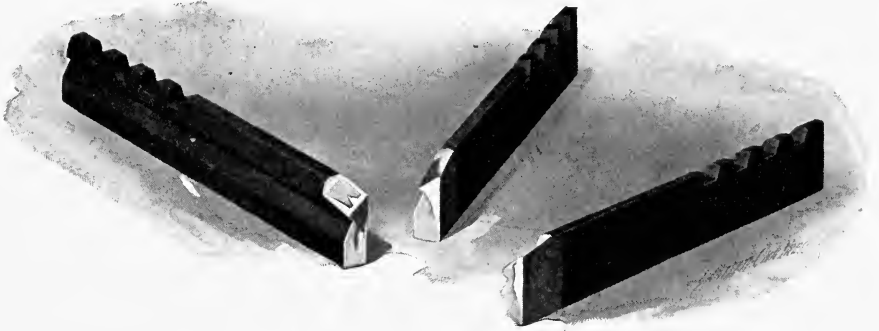

FIG. 215. Examples of Hartness tools, with sharp cutting angles.

satisfactory finish surface. The end or nose of the tool rides against the flank of the finished piece, and by giving the cutting edge and lip a suitable positive or negative back slope, the pressure against the tool, tending to force it out of the work, can be minimized; at the same time



FIG. 216. Characteristic chips. Those at the left were made by a diamond point tool having 70 degrees cutting angle. Chips at the right made by a no-clearance tool, 45 degrees cutting angle. From "Machine Building for Profit," by James Hartness.

the cutting angle can be so selected that the tool will actually feed itself into the work, entirely eliminating the feed pressure, the feed drive being required mainly in starting the cut and in maintaining it uniform. By mounting the tool in a holder or post in such a way as to afford some freedom of movement, lateral vibration in cutting is almost if not en-

tirely eliminated, and the cutting edge of the tool therefore is unimpaired by reason of chattering, which is relatively a much more important factor in its destruction than heat is, in tools not employed in exceedingly high speed or heavy feed cutting. By suitably selecting the cutting angles the tools also become, to a certain extent, self-sharpening, the lip and flank riding against the cut surface wearing along with the edge itself, though perhaps less rapidly.

For many kinds of work such tools are run with faces nearly straight, on the principle of the side tool. In other cases it is found desirable to give the tool a slight round. In turret lathe practice, when working on bar stock properly supported by back rest, the corner of the tool is left nearly or quite square.

**Utility of Hartness Tools.**—Tools of this type are inexpensive to make and seem to have a rather wide range of usefulness in the ordinary metal-working shop in connection with appropriate forms of turret lathes doing repetitive work of moderate size and not of the kind where the so-called rapid reduction, the speedy removal of relatively large quantities of metal, is necessary or economical. In diameters under, say  $3\frac{1}{2}$  inches, work up to 3 feet in length can be advantageously turned with such tools, while in diameters ranging from that given up to, say 20 inches, the lengths conveniently turned are up to nearly a foot. Diameters smaller than one inch, or possibly a little less, are not so well adapted to the use of these tools.<sup>1</sup>

**The Problem.—Taylor Standard Tools.**—The problem in designing lathe tools, and those of similar use, is in the main one of so harmonizing the various elements affecting the form, the shape of the cutting edge, and the lip angle, that the highest all-round efficiency shall be obtained with a minimum number of different tool forms. The tests and experiences of Mr. Taylor and his associates, and of many others who have adopted his standard shapes, leaves no doubt as to their all-round efficiency in roughing and rapid reduction work. They require con-

<sup>1</sup> The experiences and observations of Mr. Hartness have resulted in his formulating the following conclusions with respect to the advantages of this non-clearance type of tool:

- Relieves the edge from one-sided pressure.
- Prolongs the life of the cutter by allowing abrasion on its face without producing negative clearance.
- Converts the lip angle into a cutting angle, which for a tool of given form constitutes a gain of from 5 to 10 degrees in cutting angle.
- Extends the range of the side tool (a tool of this type is really a side tool), which gives the minimum stress.
- Makes possible the use of acute-angled tools, thereby increasing the output of machines which have been limited by lack of pulling power.
- The reduction of the cutting and separating stresses increases the accuracy (or output, which is generally interconvertible with accuracy) on nearly all lathe work.
- This reduction of stresses also increases the output, which has been limited mostly by the frailness or slenderness of the work.

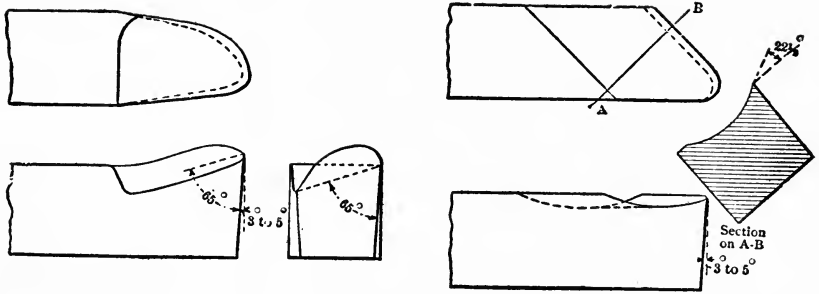

FIG. 217. Type of lathe tool much used on the continent, but not equal in efficiency to tools requiring more forging and permitting a greater number of grindings.

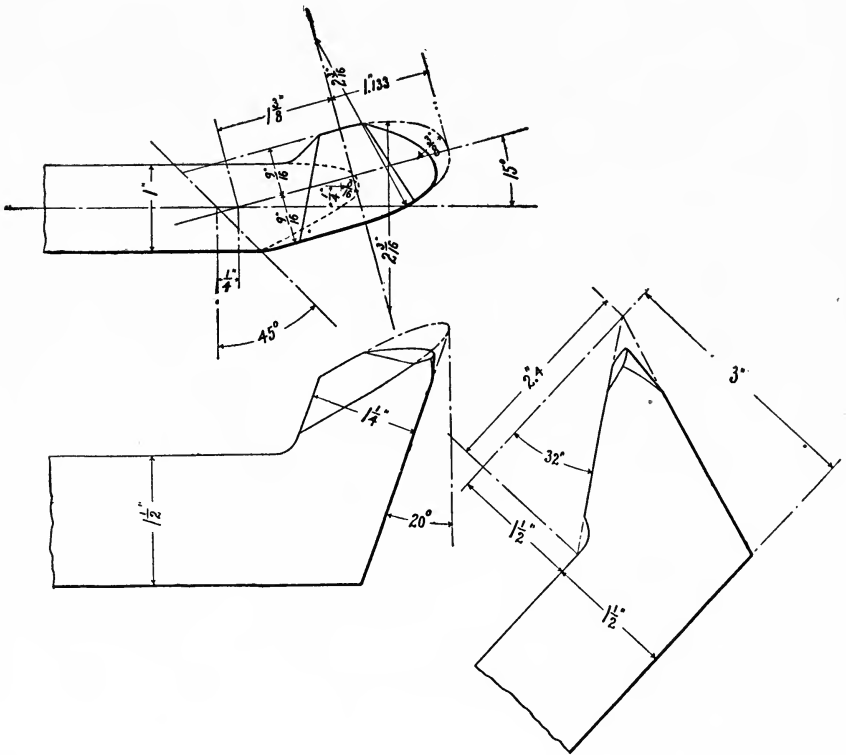

FIG. 218. Detailed dimensions of Taylor standard one-inch round-nosed roughing tool. Forged outline shown by dotted lines.



siderably more forging than tools customarily used; but this very thing is the result of a compromise in design whereby many grindings with few dressings are possible before re-fettling and re-hardening become necessary.<sup>1</sup> Of course in the ordinary run of shops, where the variety of work is large, there will inevitably be many jobs which can be better done with tools of other or of special design. It is well, however, to bear in mind always that a multiplicity of tool forms greatly complicates the tool problem; and that when all things have been taken into account it may after all be quite as economical to use a standard as a special tool.

**Tool-Holder Stock.**—In the early days of high-speed steel the tendency was to use it very sparingly, and for the most part in the form of tool-holder stock. This method permitted the use of a minimum of stock (and a consequent minimum expenditure, as it was thought) and necessitated little expense in tool making, since the stock was usually bought unannealed and was put to work after nothing more than grinding to shape. The lightness of the stock which could be used was a manifest shortcoming, which was soon remedied by the design of other tool

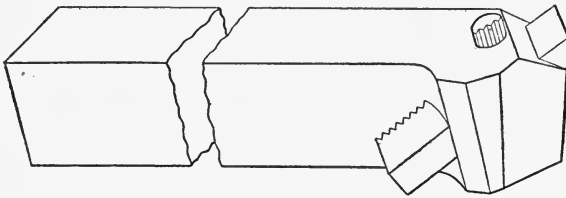

FIG. 219. A patented tool holder which allows close contact of tool and holder and insures an unusual degree of rigidity in the tool.

holders large enough and heavy enough to meet the requirements in this respect. The use of the unannealed stock, without treatment, has been found to be unsatisfactory; and the usual practice now is to treat tool-holder stock precisely as other tools are treated except that little forging, if any, is attempted. For many uses, especially for light cutting, the use of such stock, in suitably designed holders, is permissible and gives good results, though usually not so good as can be otherwise obtained.

<sup>1</sup> Following are the affirmative considerations set forth by Taylor in connection with lathe tool design:

The bar from which the tool is forged should be one and one-half times as deep as it is wide.

The cutting edge and the nose should be set well over to one side in order to avoid the tendency under pressure to upset in the tool post.

That shape should be given preference with which the largest amount of work can be done at the smallest combined cost of forging and grinding.

Forging is much more expensive than grinding, therefore a tool should be designed so that it can be ground the greatest number of times with a single dressing and the smallest cost per grinding.

The best method of dressing a tool is to turn its end up high above the body.

**Defects of Tool Holders.**—The stock of a lathe (or similar) tool not only serves to support the cutting portion, but also to conduct away a considerable part of the heat generated in cutting. In order to do the first effectively the stock must, as has been pointed out, be strong enough to prevent springing and chatter. Holders for this reason, if used at all, should be made of chrome or other very tough steel. Also, if used, they ought to be so designed that the tool itself will fit snugly,



FIG. 220. A type of composite tool, suited to scraping.

or even tightly, into the slot provided, so that there will be close contact on all sides between tool and holder in order to allow the heat to be conducted freely from the one to the other. Under the very best conditions, in this respect, there is likely to be something still wanting; and this lack is emphasized by the fact that in all such mechanical combinations of tool and holder there is introduced one additional joint in the circle which includes tool, tool post and slides, lathe bed, head stock, spindle, chuck or dogs, and the work itself, and thus brings in an additional element of negative force in high-speed cutting where especially rigidity is essential.

**Compound or Welded Tools.**—The better practice seems to be to use a stock of chrome, nickel, or other tough steel with a nose or cutting end of high-speed steel either electrically or autogenously welded on (see Figs. 151 and 152), or possibly joined by some other method of rendering the parts homogeneous, as described elsewhere. Tools so made can be forged to standard or special shapes and re-fettled as necessary. They have the requisite strength, avoid introducing additional holding devices with the consequent liability to movement, allow the heat to be conducted away from the cutting edge without interruption, and are in practically every respect equal to solid high-speed steel tools. The cost probably is a little higher than that of tools used in holders, but the advantages

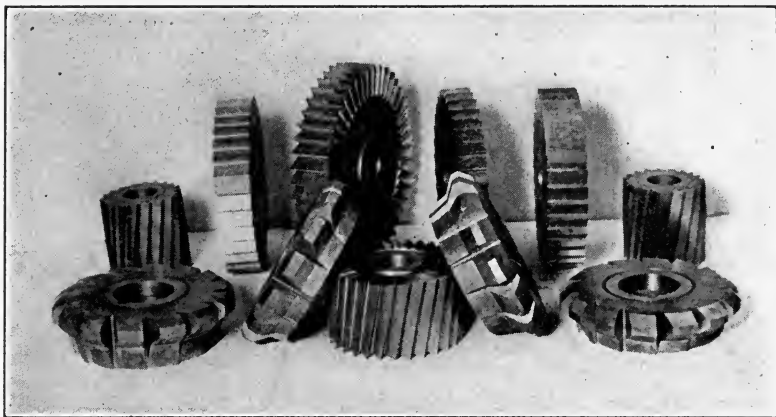

FIG. 221. Types of milling cutters best made from the solid stock.

clearly outweigh any slight difference in this respect. Tools with cutting surfaces brazed to ordinary steel bodies or stocks have been in use for a number of years in planer and similar work (see Fig. 149), and to some extent also in turning operations. Where no forging, or but a slight amount, is required, these are very satisfactory. The method does not commend itself in connection with tools of the Taylor standard shapes, or others except those of simple form.

**Composite Rotary Tools.**—In milling cutters and other rotating tools of large diameters there is opportunity for economizing in the use of high-speed steel by the use of this material for the cutter parts only, the body of the tool being in a large proportion of the cases quite as well made of cheaper material. The smaller cutters, say those below 4 or 5 inches diameter, and most irregular shapes, are usually made solid for the obvious reason that they cannot be conveniently or economically made with inserted blades, especially if held by mechanical means. A certain amount of room is required, which in small diameter tools is not available even if the number of cutters be reduced considerably below the customary; and the necessary smallness of the securing parts usually

tends to insecurity in the holding device. The objection to tool-holder lathe tools touching the lack of heat conductivity, does not hold in respect of milling and similar cutters. The cutting edges are at work for a

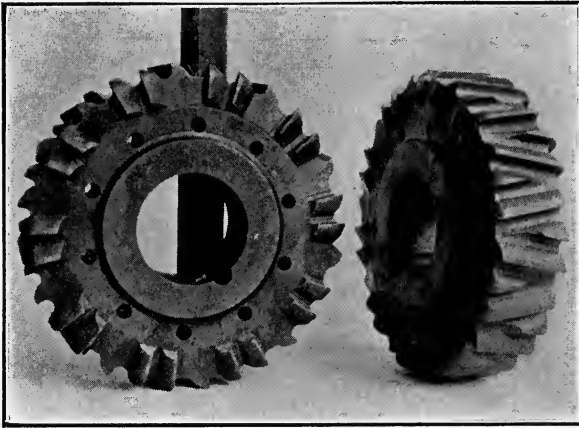

FIG. 222. Something unusual in the way of large milling cutters, 9 x 2 inches. Made from the solid because composite cutters would not stand up to the work required. The peculiar form of the teeth prevents dragging and gives free cutting angles all round.



FIG. 223. An interesting composite milling cutter. So designed that the blades are easily removed and ground simultaneously by the aid of a grinding fixture. Courtesy of Mr. William G. Thumm.

relatively short time during each revolution, and are exposed for the remainder of the time to the cooling action of the air. On this account they do not tend to become heated during a long run. In all the larger sizes, therefore, where it is convenient and feasible to secure the cutting blades mechanically, this is usually the preferable method. This the more because of the difficulties inherent in hardening not only these,

but most other large tools of intricate form. All such are to a greater or less extent susceptible to cracking, which though it may be reduced to a minimum by use of the barium hardening method or extreme care with other methods, still may possibly occur, the cracks, when they do occur, often not becoming manifest until the tool has been put at work.

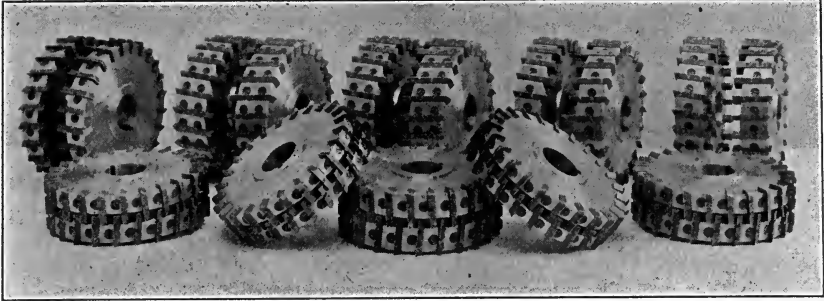

FIG. 224. Type of inserted-blade milling cutter.

This composite method permits the use of a tool body, with properly made recesses for blades and means for securing them, once made, to be used with an indefinite number of cutter sets, in this way reducing the actual tool cost on any given job very materially below what it would be if the ordinary solid carbon cutter were used.

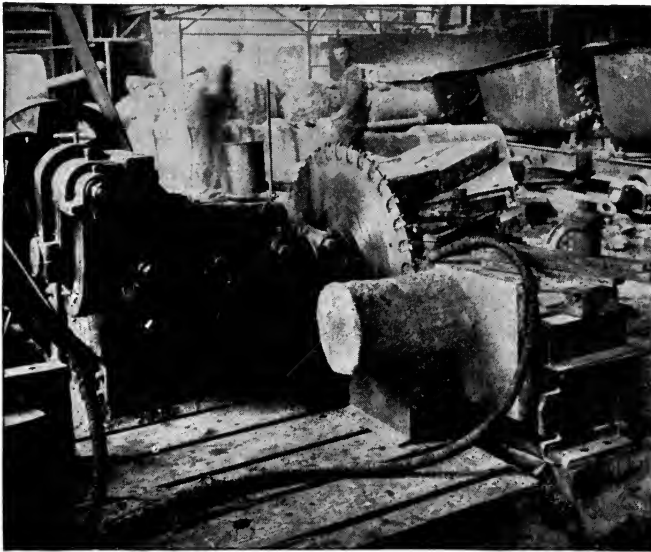

FIG. 225. A cold saw (Taylor-Newbold) with inserted teeth held in place by soft metal.

**Methods of Securing Cutter Blades.**—The methods of securing cutter blades are not only divers, but of various degrees of excellence. Brazed cutters have been used, and in a few instances also welded ones. These

methods produce the strongest tools; but they have the disadvantage of making the body, with its expensively cut recesses, usable but the once. Holding the blades in place by means of screws is, in general, to be avoided because of the well-known tendency of threaded parts to work loose and sometimes to require replacing with new and over-sized ones. Screws in some cases are used for the purpose of expanding the peripheral sections of a cutter in such a way as to grip the blades between; and this is an excellent way. Expansion dowels are similarly used, as

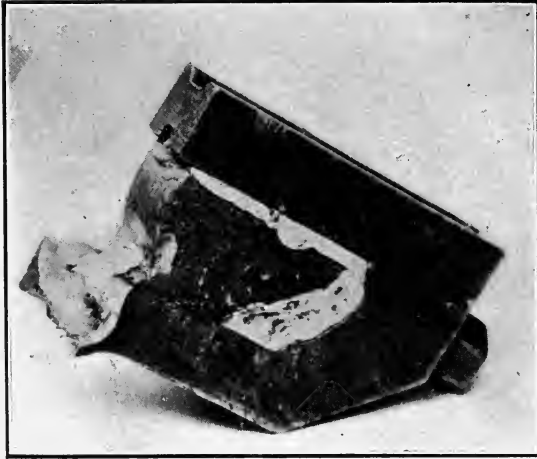

FIG. 226. Tooth of Taylor-Newbold saw broken. The tool or holder will break before the soft metal bedding the tool in the holder is materially damaged.

also are wedges. In the latter case, however, there is more or less difficulty in extracting the blades when worn out — a matter of some importance. For many uses it is sufficient to make the blades of such form and size that they are merely pressed into place with a forced fit. The method of imbedding the cutter blades in soft metal, hereafter described, also has advantages.

**Helical Milling Cutters.**—For side facing mills and others needing but a narrow peripheral cutting face, where the blades are of little length, they are sometimes straight, but are most often set at an angle so as to secure the advantage of a partially shearing cut. The same thing has been tried with long cutters, but in this case it is impossible to make a satisfactory mill without the use of helical blades. The slope and lip angle of a milling cutter blade obviously should be uniform, or nearly so, throughout its length. In very short straight blades this will be the case nearly enough for practical purposes, but where the cutters are long, unless bent to a helical form, if set with the front face at an angle with the axis, the slope and angle are uniform at no two points along the cutting edge but are modified to such an extent that the length of blades so set is thereby very

limited, and mills so made are liable to excessive vibration and chatter. In the case of helical cutting edges the front slope and lip angle can be maintained uniform throughout their length. Heretofore, however, it has been rather difficult to manufacture a cutter with blades of this form satisfactorily and effectively secured. This is now done by milling (or sometimes planing) key or pocket shaped helical slots, relatively large as compared with the blades, and anchoring the blades to the holder or tool body by filling the vacant space with some soft alloy like type metal and compressing it to insure a perfect imbedment of the blades. Anomalous as it may seem, tests have proved that blades, or

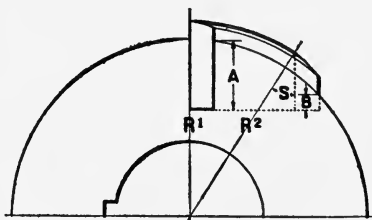

FIG. 227. Development of front slope from 0 to a positive front slope in the case of a straight inserted cutter blade set at an angle to the axial plane. Courtesy Tabor Mfg. Company.

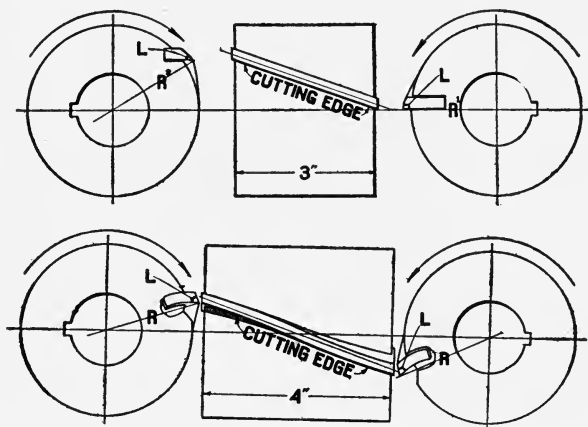

FIG. 228. How the front slope varies from the maximum at  $R^1$  to the minimum at  $R^2$  in a straight blade set at an angle of 20 degrees to an axial plane, while it remains constant throughout the length of the helically curved blade set at the same angle. The condition arising in the former case limits the possible length of the blade. Courtesy of Tabor Mfg. Company.

even holder, will usually break before the anchorage is materially disturbed by stresses upon the cutter blades. Blades so held are removed without trouble when in need of replacing. A well-known cold saw, it may be said in passing, has its teeth secured by a similar method.

**Renewing Inserted Cutters.**—This matter of renewals is dependent very largely upon the relative amount of cutter blade which can be ground away, and the method of grinding—that is, whether face or back grinding. The latter is by far the better, a very small amount of metal removed serving to sharpen the tool where a heavy face grinding would be required to accomplish the same result. The life of a set of cutter blades of this sort, then, depends upon the number of grindings that can be given it, which is to say, upon the overhang or distance the blades

project from the housing. This distance will naturally be governed by the work to be done, that is, by the stresses to be provided against. Under ordinary conditions a projection of one and one-half times the thickness of the blade is not too much. Cutters not helical in form may not permit quite so much projection.

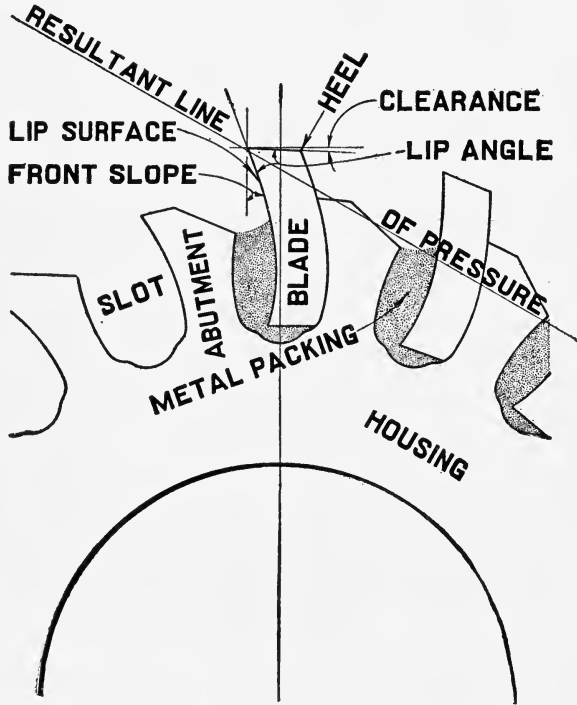

FIG. 229. Unique method of holding inserted cutter blades in position by imbedment in soft metal. The front slope is given to the blades by curving the face. Courtesy Tabor Mfg. Company.

**Maximum Number of Blades.**—Where metal is removed as rapidly as it should be with milling cutters of the high-speed type, the question arises as to clearance for the chips as they are cut away. The pitch ordinarily used in carbon steel milling cutters is insufficient, especially in cutting soft metals. Furthermore, the mechanical fastening of the blades also limits their number. Just what should be the number of cutting edges does not seem to have yet been scientifically determined. This much is known, however, that the best results are not obtained where the number of cutters is large. Coarse feeds are coming more and more to be the rule in all except fine finish milling; and for such work evidently the number of blades will be governed to a large extent (in connection with the considerations already mentioned) by the load it will be practicable for each blade to carry; for the abutments for the several blades, taken together with the thickness of the blades them-



selves, must be sufficient to withstand the probable stresses imposed. For most classes of such cutting operations the number of blades will vary from about one for each inch on the periphery in small diameters, say 4-inch, to about one for each  $1\frac{1}{2}$  inch of periphery when the diameter is as great as 10 inches. This would give about 14 blades for a 4-inch nominal diameter, 16 for a 6-inch, 18 for an 8-inch, and 20 for a 10-inch cutter. The arbor hole should never exceed one-half the nominal diameter. In the case of side and face mills, where the chips are not confined, a greater number of cutters is allowable if considerations of strength and proper securing permit. Evidently a solid cutter can have a greater number of teeth than one with inserted blades. Such an increased number, however, is not at all necessary, for the work done with one of coarser pitch will be quite as good as that with the finer. Furthermore, the cost is in the neighborhood of a third less. Usually also the life of a coarse pitched cutter will be considerably, not infrequently several times, greater than that of one with the greater number of cutting edges.

**Rake for Soft Metal Cutting.**—Milling cutters (and most other tools as well) intended to work on aluminum, and perhaps on other soft

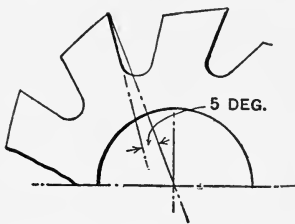

FIG. 231. High-speed milling cutters should have about 5 degrees of slope to the cutting lips.

metals also, require more rake than those cutting iron and steel, in which latter case 5 degrees is about right. An angle of 45 degrees from the vertical gives a beautiful clean finish when paraffine is used as a lubricant. The removed material does not under these conditions pile up on the face of the cutter, roughing its surface and preventing the cutting of a clean chip as often happens otherwise. The pitch or distance apart of the cutters also is necessarily greater, three teeth to a 4-inch cutter being amply sufficient, while a cutter as large as 10 inches requires but 6 teeth. More than this number is unnecessary to secure a good finish, and would be in the way of chips, preventing their clearing out properly.

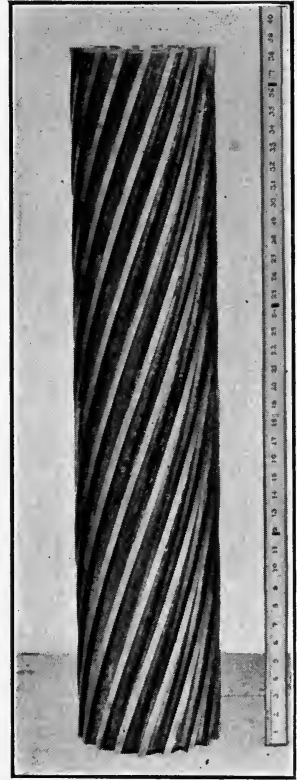

FIG. 230. A Tabor inserted blade milling cutter of some size. Scarcely feasible to make it solid. Blades secured by imbedment in type metal.

**Nicking the Cutting Edges.**—The question as to whether the cutting edges of long mills should be nicked or not is still open, though it would seem that if the cutters were designed with a front slope such as to bring down the chip pressure there would be no occasion for breaking up the chip. This front slope is an important factor in the efficiency of milling cutters.

**Interlocking Mills.**—Wide face cutters, when solid, are preferably made in interlocking sections, as also are those used for producing

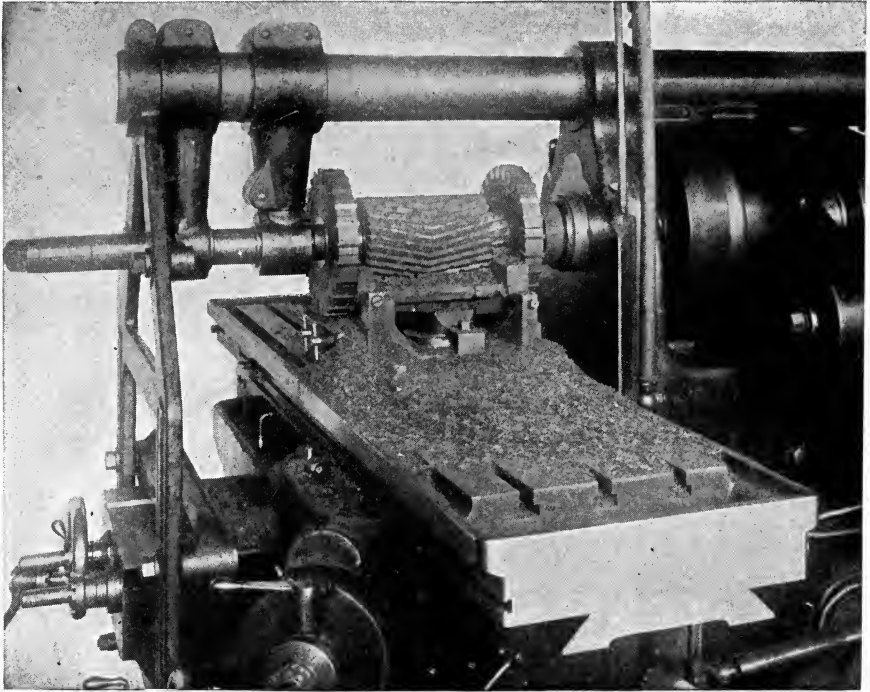

FIG. 232. The gang milling cutter, built in sections in order to simplify problems of manufacture, hardening, grinding and maintenance.

finished surfaces with a variety of curves, slopes, or angles. In the latter case gangs are used, a separate cutter for each surface or curve, usually. The difficulty of properly hardening a single cutter of extreme length or intricate form would be sufficient reason. A further one is that in case of damage to a portion of such a cutter, if made in sections the damaged part can be replaced without the expense involved in the making of a complete new cutter.

**The Case of Rose Reamers.**—Rose and similar reamers have several points in common with milling cutters, yet in certain respects are in a class by themselves. Those used in a vertical position, for enlarging and truing cored holes, discharge their cuttings freely; but those working

in a horizontal position often present a difficulty in this respect, and require greater clearance in order to avoid clogging and other troubles. As in milling cutters, in order to secure a sufficient clearance, and at the same time sufficient strength in the backing or abutments supporting the cutting edges, the number of the latter is reduced as much as a third, frequently, below the customary.

**Composite Reamers.**—Small sizes, say up to  $1\frac{1}{2}$  inch, are preferably made solid, and above that diameter with inserted blades, though some as small as  $\frac{1}{4}$  inch are made composite—and adjustable at that. The manner of insertion may be either mechanical or intimate, as with milling cutters,

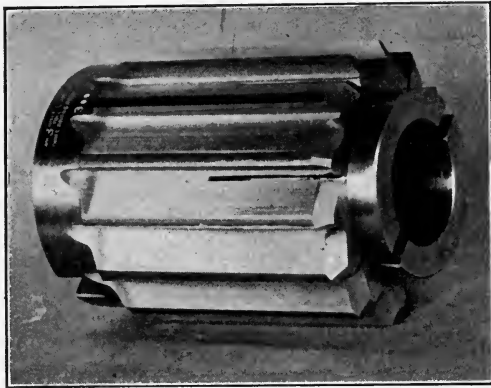

FIG. 233. Matthews expanding shell core drill or reamer. Expansibility secured through slotted shell in combination with an expansion bolt.

though in the former case the mode of holding is essentially different. If intimately attached, so as to make a practically homogeneous tool, either by brazing or by welding, the effect is that of a solid tool which may be ground off without reference to saving the core or body. This is convenient, especially when the operator is required to grind his own tools—as he should not be. By the use of suitable collars and other well-known devices the blades may be secured at both ends, and when ground away until no longer serviceable are quickly replaced by another set. Likewise there are reamers whose blades are forced with a drive fit into the grooves cut in the body of the tool; and still others with blades wedged in or secured by screw devices. Almost any of these are efficient in light or moderately heavy work, particularly if used as floating reamers for sizing rather than for boring. When, however, extra heavy service is required there is some difficulty in securing the blades mechanically so that they will stand up to the work. It is desirable in this case that the blades be brazed or welded—and to cores strong enough not to twist off at the shank.

**Material for Stem or Body.**—To afford the requisite strength in tools of the last mentioned kind, the body and shank are best made of a

tough chrome or similar steel. Machinery, and even tool steel shanks, not infrequently twist off under the heavy stresses imposed by severe duty. For ordinary work under customary conditions the bodies are strong enough if made of machinery, or at best of tool steel. Occasionally it may be desirable to make them in the form of steel castings, though usually the ordinary method will be followed. Bronze metal bodies, with the slots for the blades milled in the customary manner, also are in successful use. The blades in this case are brazed into the recesses. Cast or malleable iron bodies are to be avoided.

**Clearance and Relief in Reamers.**—High-speed reamers especially, and perhaps more than the slower carbon steel sort, require a sufficient and proper clearance or relief. Too much will result in chatter, while too little will lead to binding in the hole and consequently to short life. Flat relief, that is, a flat land behind the cutting edge, or front face of the flute, is not nearly so good as a curvilinear, the so-called eccentric or radical, which not only gives better support to the face of the flute but also helps to steady the tool and produces a better hole.

**Expansion or Adjustable Reamers.**—The work of a rose reamer is essentially different from that of either a milling cutter or of a drill, since the former removes but a relatively thin skin of material from the

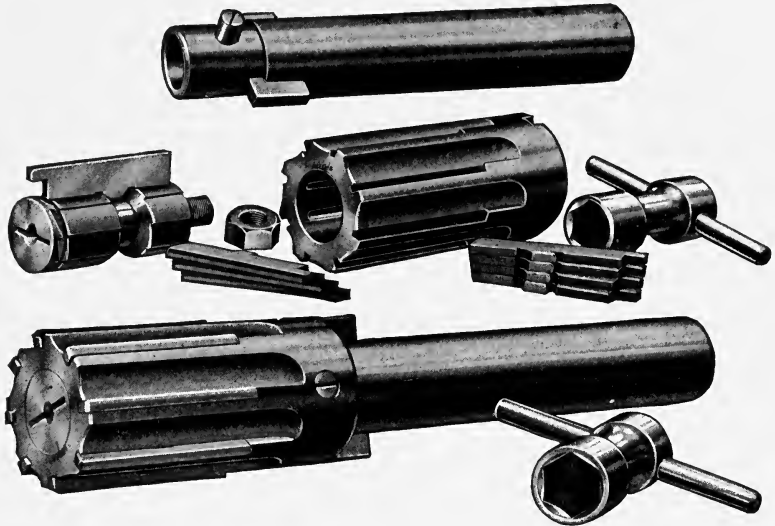

FIG. 234. Smith adjustable reamer assembled, and parts of same.

inside of a hole already existing; and unlike either, it takes this off not with a broad cutting edge, but with a small corner of the cutting lip at the periphery of the tool. In consequence nearly the whole wear comes just at that point in the reamer which gives the size to the hole. And since the only way in which work of this character can be kept within

the requisite limits of precision is to keep the tool also within those limits, it is necessary to keep such reamers well sharpened by frequent grindings, or to provide for taking up this wear by some method of expansion which will again give the required diameter. In most cases where the nature of the work is such as to permit the use of tools of that type, the expansion reamers are preferred. The simplest form of such a tool, perhaps, is that in which the blades are welded or brazed to a slotted shell provided with a taper plug and take-up screw. In another well-known tool, with removable blades, the expansion is accomplished by rotating a locking cam bolt with cams corresponding to the blades.

**Twist Drills.**—In fluted twist drills there has been little change from the standard form previously in use, though it is desirable that the lead of the flutes be given some advance over the customary one of about seven times the diameter. The smoothness of finish somewhat affects the possible speed and therefore the efficiency of drills. Provision should therefore

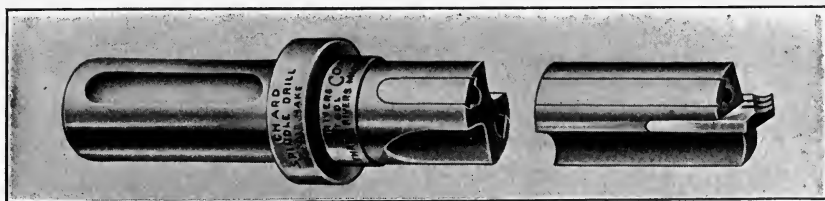

FIG. 235. Chard spindle drill.

be made for a finish approximating a polish. The one especial feature wherein the high-speed drill can well differ from the ordinary is in the thickness of the web. In order to give the greatest possible degree of stiffness and strength where most required, it is a desirable, but by no means an universal practice, to increase the thickness of the web gradually toward the shank. It is important that the web, especially when the drill has become somewhat shortened, should in grinding be thinned at the point in order to minimize the tendency to split which sometimes manifests itself at the high pressures required to feed these tools into the work. Likewise it is not only important, but essential, to provide for the grinding of a proper clearance to meet the requirements of the feed intended to be used, and, as explained elsewhere, for so varying the clearance angle from center to periphery as to allow the drill to feed properly into the work at all points along the cutting edge.

**Twisted Drills.**—For a time at least one maker of high-speed steel rolled sections of such shape that when suitably twisted and provided with a shank, a fluted twist drill was produced which required only to be finished and ground, the cost being surprisingly small. This was, in a sense, a reversion to the original method of making drills of this type. The maker after a time ceased rolling the drill stock section; but

others have since then taken up the idea and now several forms of drills are manufactured in this way, ranging from those twisted from flat stock to others rather closely approximating the standard milled fluted drill. There is no difficulty in producing a shank suited to any requirements, from the regular taper to special forms adapted to use in connection with special collets or chucks. In one style the lead of the twist is considerably increased at the shank end so as to form a good bearing, which when ground not only fits the standard taper socket, but



FIG. 236. Twisted drill made from a flat bar of stock throughout its entire length. Shank ground to standard taper.

by reason of the tendency to untwist under the stress of work, it actually grips the taper seat more firmly than a solid shank drill does. Other styles have hot pressed or slightly forged shanks, flat or flat-taper, as the case may be.

**Economy in Twisted Drills.**—The manufacture of drills of this type obviously is a much simpler and cheaper matter than that of the ordinary fluted drills. The amount of metal required is only about one-third as much by weight, which of itself is a matter of consequence; and the twenty odd operations involved in the manufacture of ordinary drills is reduced to a small fraction of that number. No expensive or elaborate special outfit is required to make them, and it is therefore possible to produce drills of this type in many shops otherwise not equipped for drill making. In addition to all these things, it would appear that drills thus twisted are stronger than those milled from the solid cylindrical stock and that tangs very rarely twist off or stems break under the strains of their work. Obviously the grinding and finishing must be as carefully done as in the case of the ordinary type.

**As to Other Tools.**—There does not seem to be any reason for departure from traditional lines in the design of wood working and of metal working tools other than those used for rapid cutting, except in so far as it is desirable to make all these tools so far as permissible on the composite or built-up plan. Small dies, punches, shears, and the like tools are preferably solid; but large sizes are just as well, or better, built up in such a way that the parts subjected to wear may be renewed from time to time as required.

## CHAPTER XVIII.

### THE NEW MACHINE REQUIREMENTS.

**Limited Use of High-Speed Tools.**—The revolution in machine shop practice, so enthusiastically predicted for some time, unquestionably is arriving; but, it seems, rather more slowly than might have been expected; and it is as yet manifest in spots only, so to speak. Considering the very great advantages obtainable by the extensive and intelligent use of high-speed steel tools, it is surprising, not to say disappointing, from the efficiency point of view, that they are as yet used so little and so ineffectively in general manufacturing. In such plants as have for their principal product heavy forgings or machinery, or other products

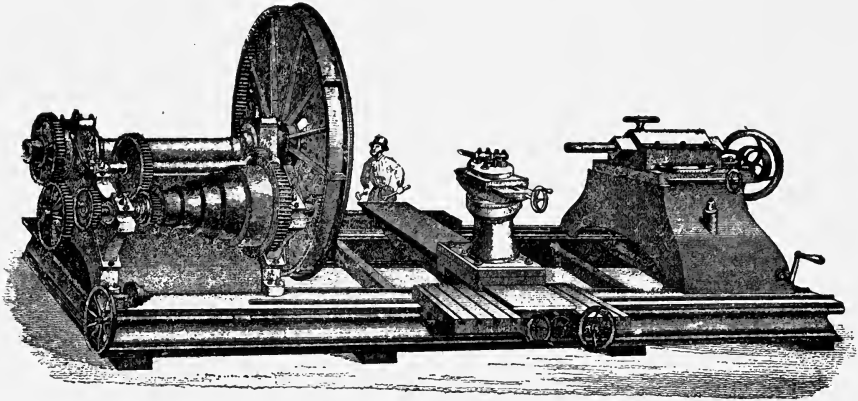

FIG. 237. An extraordinarily large and heavy lathe in its day. Built about 1856 by the Phoenix Iron Works, Hartford. Compare the weight and build of this machine with a modern high-speed lathe of about the same swing, as seen in Fig. 238.

comparable to them, the new steels have a large and not infrequently exclusive place. In a relatively few shops turning out products of a different character, say such as would be typified by agricultural machinery, sewing machines, and watches, advantage is also taken of the new steels and their high efficiency. In the average factory, however, the extent to which they are used is astonishingly small. There are indeed places where high-speed steel seems never to have been heard of, or where the management is so ultraconservative as apparently to deserve being under suspicion of inefficiency and to need reminding of the adage which says something about penny-wise and pound-foolish.

There are of course many considerations affecting the use of high-speed steels, and these are discussed in another place. One of the most important relates to the nature and effectiveness of the machine tool equipment; and it is this which particularly concerns us at present.

**Incapacity of Old Equipment.**—It scarcely needs mentioning that machine tools designed under the old *régime*, to meet the requirements and reach up to the limitations of the old tools, are utterly incapable of using efficiently the new tools, with their doubled, trebled, and even quadrupled powers. It may be necessary or expedient to use such equipment even in connection with high-speed tools, as pointed out in another place;

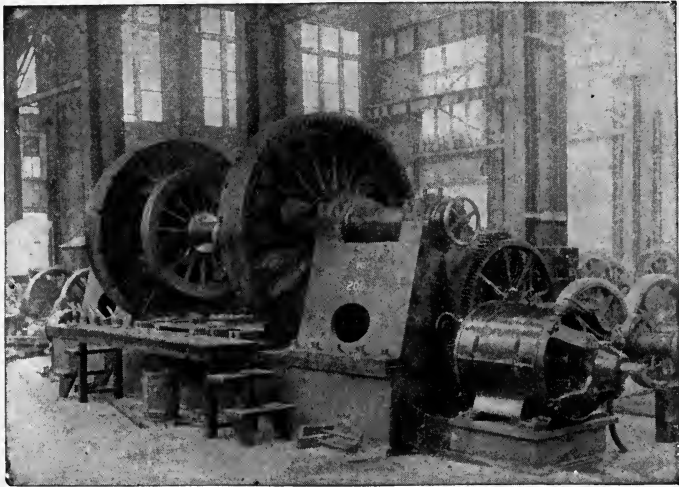

FIG. 238. Example of powerful and massive lathe especially adapted to use high-speed steel tools. Double head, one of which has traverse. Feed and headstock traverse both secured through an auxiliary motor seen at the farther end of the machine. 80-inch Niles driving wheel lathe.

but in the acquisition of new equipment there certainly should be no hesitation in selecting that which will measure up to the full powers of the new tools, and then to use those tools at their maximum efficiency.

**Sufficiency of the New Types.**—During the first years of high-speed steels, machine tools fulfilling the new requirements were not often to be found. Builders were cautious in the matter of new design and the expense of putting out new types of machines — though it may be supposed that they were no more conservative in this respect than the market demands made prudent. The early attempts at adaptation to the new standards were mainly in the way of modifications of existing designs. There was some increase perhaps in the weight of beds and frames, and a disposition to displace the narrow, many-stepped cone pulleys of the ancient yesterday with others having faces somewhat broader. But there was much hesitation in the bringing out of machines newly designed, with the problems presented by the new tools as the basis of



many departures from tradition in the working out of general form as well as of details. At the present time, however, it is possible to obtain machine tools of almost any type which will measure up to the maximum requirements of the new tools, and which possibly surpass them in some cases. This being so, it is pertinent to inquire as to the elements which should be considered in the selection of machines under the new *régime*.

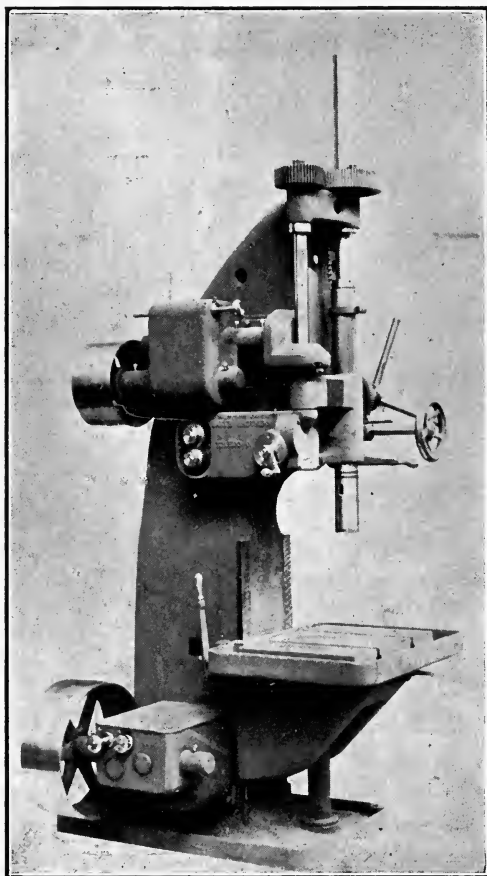

Fig. 239. A drilling machine that fulfills the most exacting requirements for a high-speed, high-power tool. Made by Baker Bros., Toledo, Ohio.

**Producing Repetitive Work.**—Before attempting to indicate some of the most important of these, it is pertinent to point out that the question of machine tools may well be looked at from two very different view points by the two classes of machine users to whom it might be supposed to be of interest. The requirements of the shop doing little but repetitive work, the reduplication of pieces in great numbers, pieces which need to be “good enough” merely (or even which need to be of extreme

accuracy, though possibly to a somewhat less degree), will be much simpler and perhaps less exacting than those of what might be called the general job shop, where a given machine may be called upon to perform a great diversity of operations upon a large variety of different kinds of pieces. In the former the use of the jig and similar devices to hold the piece operated upon and to guide the tool to insure accuracy, makes possible in most cases the satisfactory use of machines fulfilling two essential requirements: ample powering and sufficient rigidity or strength. Even the latter is essential not so much for reasons of accuracy as to insure longer life to the tool through the elimination of vibration.

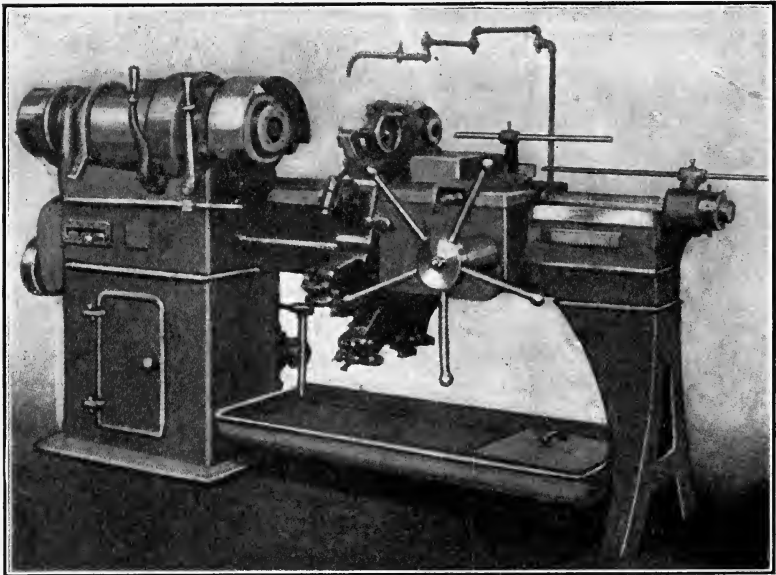
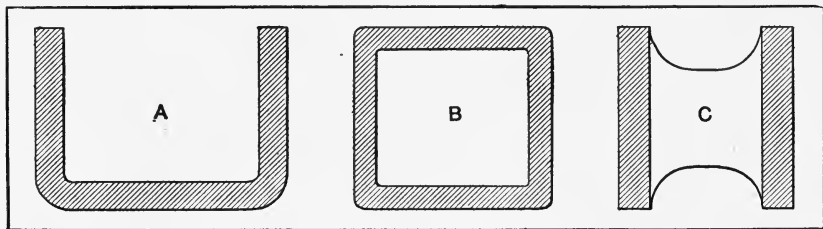

FIG. 240. An interesting effort to meet modern requirements in repetitive production.  
The Foster ring-turret lathe.

The small range of work generally done upon a given machine, under the conditions named, not only eliminates the need for a great variety of speed changes (once the proper speed for the jobs to be done upon it has been determined), but actually makes such a variety a needless source of expense and something of a nuisance besides. The tendency, in shops having a very large output at any rate, is toward the highly specialized machine, designed specifically for the performance of a single operation or a very few specific operations, on particular parts. For the single operation machine but a single speed and but few adjustments are required; while for the other, the speed changes may well be closely restricted.

**The Case of Engineering Works.**—Manifestly the shop turning out a limited number of pieces of a kind and doing a large variety of work, whether it be the tool room of a big factory, the general manufacturing shop, or the small jobbing shop, requires a different class of machines. Since jigs and rigs are of necessity but little used, precision must be obtained through accuracy in the operation of the machine. For this reason the machines must meet the additional requirements of extreme rigidity, considerable range of adjustability, and likewise large range of speed variation. Whatever the type of machine, the considerations here pointed out apply with more or less force to all of them.

**Solidity and Rigidity—How Secured.**—Much has been said, and not a little written, about the so-called “anvil” as opposed to the “fiddle” principle in machine design; and it was pretty well established even before the advent of the new tools that solidity, or rather rigidity, is a prime essential in machines for metal working. Solidity and rigidity



*The Engineering Magazine*

FIG. 241. How the disposition of material in structural forms affects strength and effectiveness in resisting strains. *A* and *B* are three and four sided prisms. *C* is in the form of two girders connected at intervals by girts. *B* has 10 times the torsional resistance of *A*, and from 6 to 13 times that of *C*, the ratio depending upon the strength and frequency of the girts in *C*.

are by no means the same thing. Mass of course does involve inertia, and likewise rigidity. On the other hand it is possible to secure comparative freedom from vibration without the heavy massing of material often found, if the material be properly distributed. It is well known, for instance, that the hollow cylindrical form of construction is very much stronger in every way than the solid, utilizing the same amount of material; and this fact is made use of in a great variety of ways—nearly every way, one might have said until very recently, except the construction of machine tools. The hollow prism form also has great advantage over the solid, considering the amount of material involved. It has been shown experimentally that a hollow four-sided box of this rectangular prism shape (Fig. 241) is more than six times as rigid with respect to twisting strains as the same amount of material in side plates with cross girts of the customary proportions. Even the very best possible distribution of material in this form (beams and girts) does not reduce the disproportion more than half. Consequently the very best lathe bed designed on conventional lines can have a strength

ranging only from possibly a fourth (making a very liberal allowance) to an eighth of the rigidity it might have if the material were distributed in the box form. Now the chief business of not only lathe beds, but of the frames of nearly all machines designed for rotating the work or the cutting tool, is to resist such twisting strains; and principles of rational design should indicate the advantage of this simple mode of reducing the weight of metal required, or rather of securing the maximum of strength and rigidity from the metal used. The nearer, therefore, a lathe bed

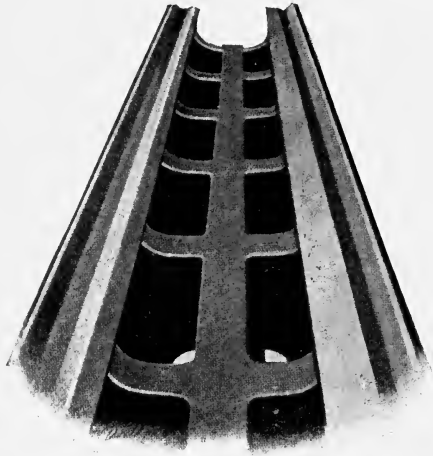

FIG. 242. A heavily girted lathe bed.

approaches this form, the greater its efficiency. The same thing holds true of such parts as the cross rails of planers, multiple mills, and the like machines. These most frequently have been made trough shaped, with a section resembling a box of three sides rather than four — a form lacking in resistance to torsional strains, and only about a tenth as strong otherwise as if one-third of the metal were distributed in the form of a fourth side.

**Weight Essential.**—It should not be inferred that lightness is in any wise desirable in machines designed for using high-speed tools. The heavier the frame, that is to say the greater the solidity, the better the absorption of vibration such as inevitably occurs in heavy or rapid cutting; and the better this is absorbed, the greater the efficiency at the cutting edge. The point is that there shall be ample weight, and that this weight shall be distributed for greatest effectiveness in resisting the kind of strains to which the particular machine is to be subjected. And this applies no more to lathe than to milling machines, planers, and the rest of the tribe of machine tools.

**Lathe Heads and Others.**—Next in importance to the bed, frame, or body of a machine, is the driving or cutting head. Obviously it ought to be in strict proportion to the rest of the machine. It needs strength and



FIG. 243. "Lo-Swing" lathe (rear view) of the Fitchburg Machine Works. Unique design of bed — and indeed of machine throughout.

rigidity just as much as the body does — but no more. The practice of putting abnormally large heads upon machines otherwise of moderate resisting power, as was done to a considerable extent at first, by no means makes a high-speed machine of an ordinary one. There is no more reason for putting a tremendous head upon an ordinary machine, producing a megacephalous monstrosity ("hydrocephalous," somebody has facetiously remarked, possibly in reference to the designers rather than to such machines themselves), than there would be in using an immense tool without a suitable support. The head must have solidity, however, and must be large enough to allow for the increased size of bearings necessary for the higher speeds and heavier driving; and in case gears take the place of pulleys, to accommodate the change gears requisite to the type of machine. It is important that the attachment of the head to the bed or body be such as to insure the greatest possible stability; and this precludes, except in machines of special type intended for special service, any adjustability of these parts. A satisfactory attachment is of course possible if the contiguous bases are sufficiently large, well fitted, and securely bolted. No such attachment, however, can be as rigid as if the parts were made in one solid piece; and some of the best

types of machines now have frame or bed and head cast in a single piece. This naturally involves larger and more complicated castings, and it

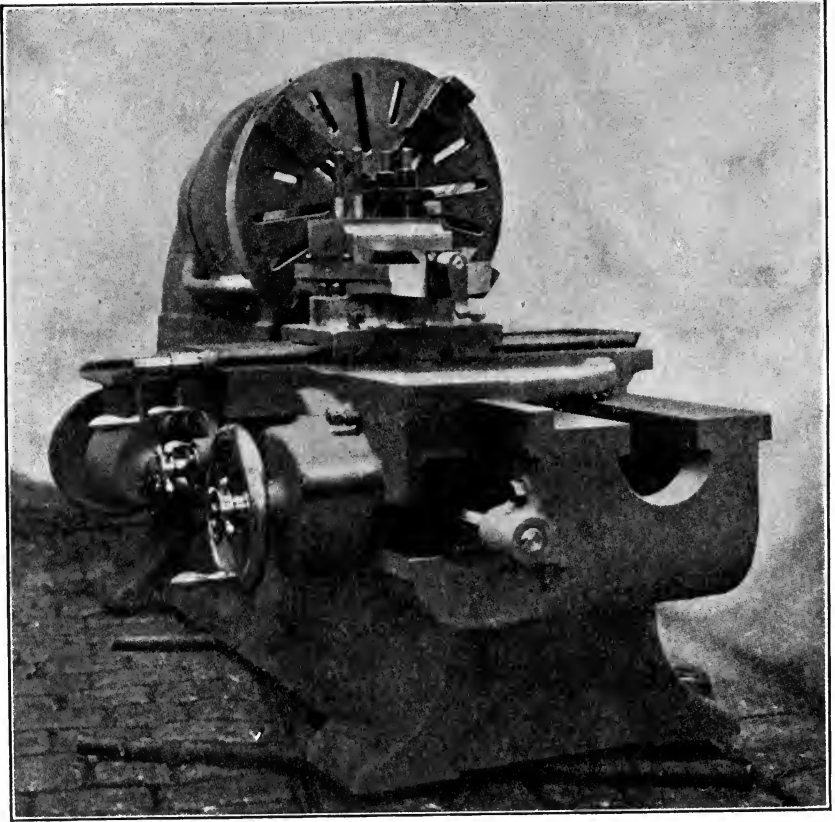

FIG. 244. Good example of English lathe design. Darling & Sellers.

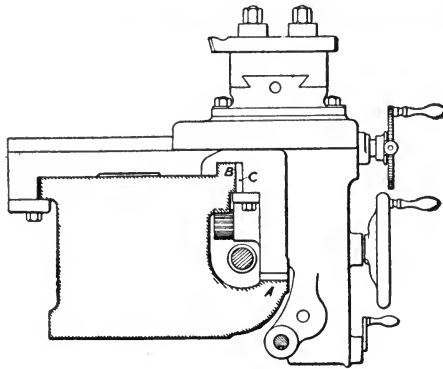

FIG. 245. Section through Darling & Sellers lathe bed and carriage.

would be interesting to learn if the same results might not be obtained by casting in two pieces (or more) as heretofore and making them homo-

geneous by one of the several processes of welding now successfully employed in other ways. There seems to be no reason why this should not be the solution to the rather vexing problem of how to secure the largest amount of rigidity with moderate cost of manufacture.

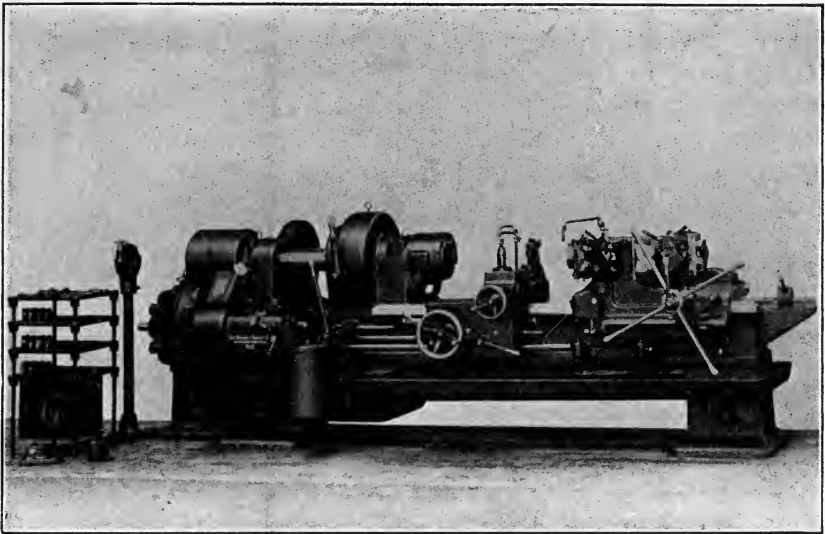

FIG. 246. Warner & Swasey hexagon turret lathe. Head and bed cast in one piece; direct connected motor drive; flat turret carriage.

**Proportions of Bearings.**—Properly proportioned bearings are much more important in the new machines than formerly even. Not only is the highly increased speed to be considered, but also the very largely increased pressures. To meet these conditions the bearing surfaces must be large, and of material best calculated to resist wear and to avoid friction. Considerations of space as well as of rigidity make it preferable that the augmentation of bearing surface should result from increased diameter rather than greater length. This permits also the use of hollow spindles, which again tend to greater strength and rigidity and permit the better use of gears in the driving mechanism.

**Lubricating Devices.**—In machines of the types heretofore standard the matter of lubricating bearings (and gears, when used) has not been particularly troublesome. Under the new conditions it is less simple. The tremendously increased pressures and friction make it necessary in many, if not in most cases, to provide some means to insure free and certain lubrication. This involves often the designing of special devices. An ingenious example is that used on one high-speed lathe, Fig. 250, wherein the bearing is surrounded by an oil-filled well. Oil is continuously dipped and carried in sufficient quantity to the highest part of the spindle and is conveyed to all parts of the bearing through the

customary oil grooves. A glass tube inserted in front and properly protected serves as a level indicator. In another instance (Fig. 247) the gears are about half immersed in oil contained in the pan formed by the gear case. Of course both are well covered. In the case of certain

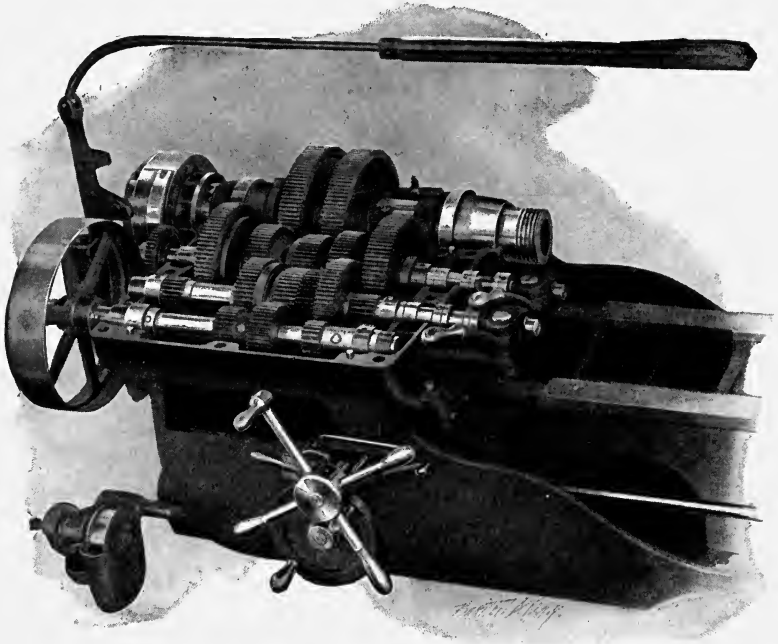

FIG. 247. Headstock of hartness flat turret lathe. Cover removed to show gears and oil pan. The gears run in oil.

very heavy duty machines it has been found desirable to force oil into the bearings by small force pumps.

**Secondary or Tail Stocks.**—In machines requiring a secondary stock for the support of the work turning on centers, as in the case of the

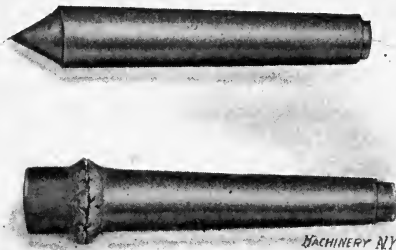

FIG. 248. Making a lathe center with a high-speed steel cone. The welded spindle with bur, and same completed. Courtesy Thomson Electric Welding Company.

engine lathe, this tail stock must be designed with reference to heavy service; that is, with sufficient base, heavy weight, and security in fastening to be in balance with the head stock. It is desirable that



there be some provision for positively bracing it against the bed. The tail spindle, and indeed all centers subjected to much wear, should by all means be of high-speed steel. It is not necessarily solid, however, for it is sufficient if a high-speed steel center end be welded or otherwise securely attached to a tool steel shank. In large machines it is desirable that the tail stock or secondary head be moved as required by an auxiliary motor.

**Tool-Holding Requirements.**—Much attention has heretofore been given to securing a great variety of adjustments in the mechanisms employed to hold the tool and to bring it to its work. The result is that compound rests have not infrequently been “fearfully and wonderfully made,” in order to give a maximum of adjustment and movement.

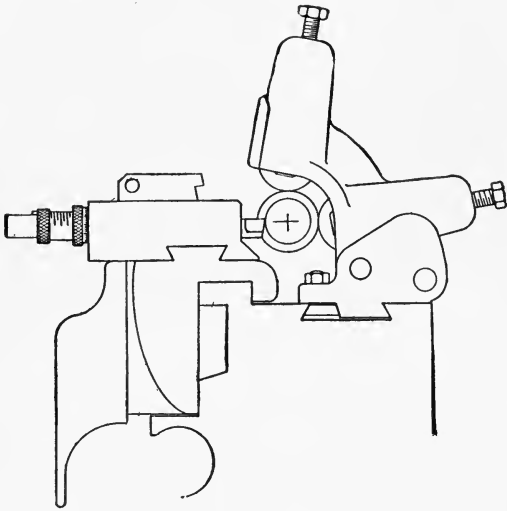

FIG. 249. Method of attaching back rest and carriage in “Lo-Swing” lathe.

While of course refinement of adjustment and facility in bringing tool and work together are desirable in high-speed cutting also, it is still more desirable that they be brought together as rigidly as possible. Every joint means a reduction in rigidity; and in work requiring freedom from this to the extent necessary when working high-speed tools at a high efficiency, evidently the fewer slides and other adjustments, the better calculated is the machine to do its work with the minimum of vibration. Absolute freedom from vibration is not possible in a cutting machine. The absence of chattering or of tremors capable of being sensed does not necessarily indicate that they are not present to some extent. At the best they can but be minimized. The tool-holding device and its adjuncts must compare, in rigidity and strength, with the rest of the machine, and require wide bases combined with the least possible altitude. It is not at all essential that the shank of a tool shall

be horizontal, in the case of a lathe, for example; so that there need be no difficulty in considerably lowering the position of the tool with reference to the working center. The same consideration holds in the case of all other machines. Thus that milling machine is best adapted to high-speed work (other things equal) which has short arms and holds the tools closest to the main frame; and in planing, the least torsional strains are thrown upon the cross rail when it is possible to cut with the tool point very nearly in front of the rail rather than below it. It may be added in this connection that the sharp angle or unusual rake permitted in the case of one well-known special lathe is in large measure due to this practical elimination of torsion in the bed, the reduction of slide movements to the irreducible minimum, and the lowering of the tool to the greatest possible extent. Reciprocally the tool reduces the pressures and consequent strains, and there is insured better work with lower power consumption than often is the case.

**Increased Power Required, not Waste.**—The powering of the new machines, providing them with pulling power adequate to the needs of the new situation, has developed to a satisfactory state, though not infrequently mere modifications of former types have been attempted in the effort to remodel old designs—generally with small success. It is understood, of course, that increasing the amount of cut, in metal cutting, increases the power consumed; and also that increasing the cutting speed does the same. The increment, however, is by no means proportional to the greater amount of metal removed, and it by no means follows that because a machine consumes power rapidly, energy is going to waste. It is demonstrable beyond question that an efficient, high-powered and high-speed machine using a tool of the new type has an efficiency very much greater than the old machines even if the absorption of power alone be considered in relation to the amount of work done. In other words, on the basis of time consumed and metal removed, a strictly modern machine uses considerably less energy per unit than do the former standard machines.

**The Belt-Driven Machine.**—Of course extremely heavy cutting is necessarily confined, in large measure, to shops doing a particular class of work (comparable to armor plate and gun making operations, say), and have a relatively small place in the ordinary run of general manufacturing. Nevertheless, the effective use of high-speed steel in this very kind of general manufacturing requires high-powered machines also. Obviously heavy driving power is out of the question in connection with the multiple cone pulley, even if nothing be taken into account other than considerations of space and the danger connected with the shifting of rapidly running belts. If a belt drive is necessary, that machine should be best suited to the new requirements which has but few steps in the driving cone pulley (say not to exceed three), or

which has no step cones at all. In the latter case all variations in speed are of course obtained through a variable speed countershaft, a gear box, or the two in combination, the number of changes required being determined by the nature and variety of the work for which the machine is desired. In general manufacturing, as already intimated, a great variety of speeds and feeds is not only unnecessary but often a source

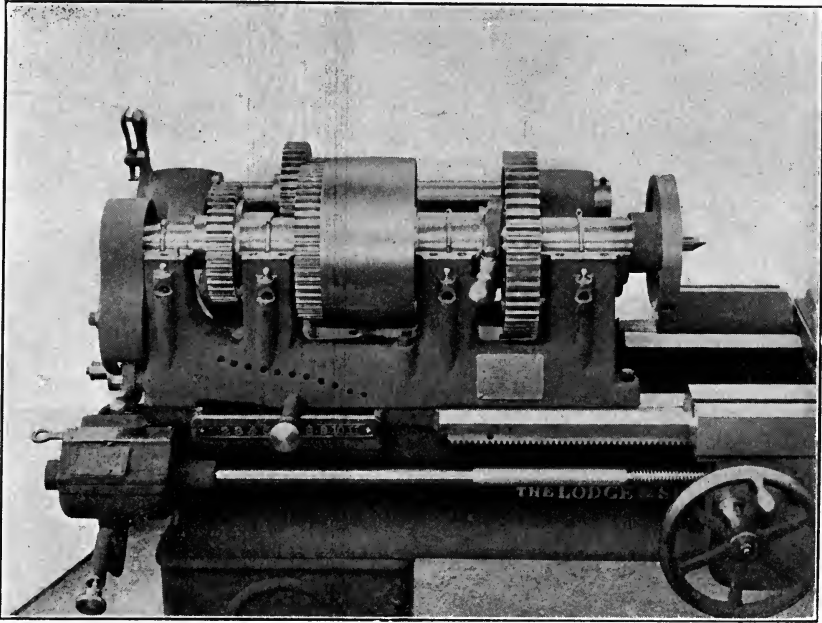

FIG. 250. Lodge & Shipley single-face pulley drive in connection with gear box. Cover and bearing caps removed to show positive lubricating device.

of needless expense and annoyance. Wherever possible, it is better to have the machine drive suited to a small range closely accorded with the requirements of its special work.

**Few Speed Changes Necessary.**—The gear box in connection with a variable speed motor offers a combination with which are obtainable a maximum number of speeds in cases where the work of a machine is much diversified. Even in such instances the number of different speeds really necessary need not be very great. The new tools lend themselves admirably to wide latitudes in respect of speeds, and feeds also; so that in spite of an evident tendency in some directions to require more rather than fewer changes, it would seem the better plan in general to get along with the less number, except under special circumstances.

**Amount of Power Absorbed.**—The amount of power consumed by machines under former conditions has been very generally overestimated because, among other reasons, the proportion absorbed by line and

countershafting and other transmission devices has been underestimated. Except in case of very powerful machines the energy absorbed per unit, while cutting, rarely exceeded one horse-power. The newer machine tools of similar capacity require rarely less than three or four horse-power, and not infrequently several times as much. A 20-inch swing lathe, to take a concrete example, running at high-speed and taking a heavy cut, has on occasion absorbed a maximum of 30 horse-power, though its average consumption is less than 10 horse-power, and the minimum a good deal less than that. In turning operations, under favorable conditions, the power absorbed per pound-hour of metal removed varies from 0.03 to 0.07 horse-power, over and above that required to drive the machine itself. This is measurably less than under former conditions, where the consumption has been close to 0.05 or 0.06 horse-power and upwards.

**Belts for Auxiliary Drives.**—Using up power so rapidly, pulling loads as heavy as are thus required at the high speeds conditioning the work,

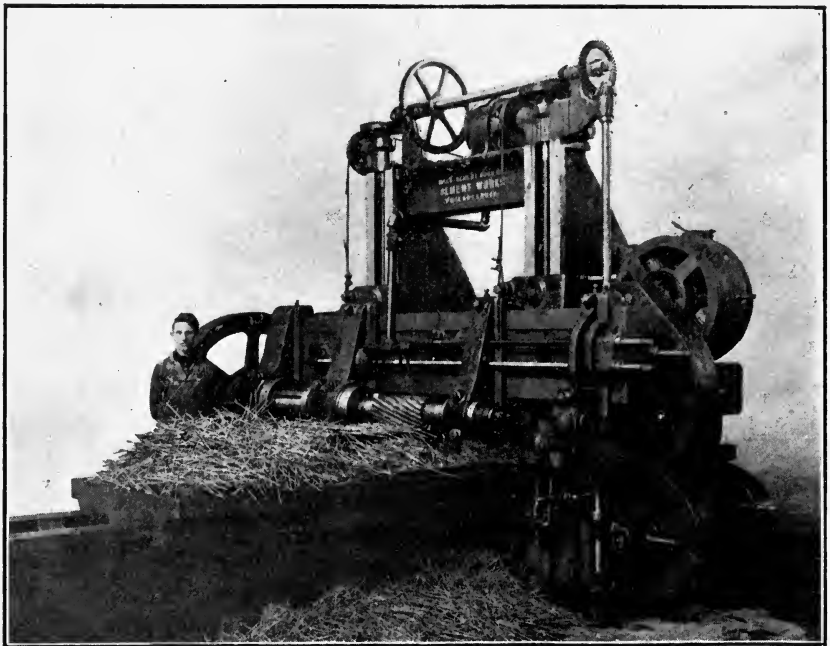

FIG. 251. A heavy milling machine with auxiliary motors for movements other than the main drive.

means practically the elimination of belt drives for the auxiliary movements of a machine, and the modification of the main drive also, as above pointed out, with the tendency apparently toward a main drive pulley, where this is used at all, of but one belt face, and that driven

whenever possible by a silent chain rather than by a belt. The speed changes and the auxiliary drives, therefore, are through gears; not only in the main drive, but in the feeding and other movements wherever these are necessary. The gears are put under such stresses that the ordinary ones are quite unsafe, and only steel or bronze is permissible as a material in view of the limitations necessarily imposed as to size. Steel rimmed gears also are satisfactory in large sizes. Of course steel gears are positive — too positive for the safety of the machine, it is sometimes urged; but shearing pins or other safety relief devices obviate any possible objection on this score. It is important to bear in mind that the feeding stress may under abnormal conditions (as of a very dull tool, for example) quite equal the driving stress; and it is therefore essential that the feed mechanism be, if not just as powerful as the drive, certainly adequate to the probable exigencies to be met in the operation of the machine, and therefore much stronger than usually found under former conditions. It is desirable also that all high-speed machines be provided with good braking devices for quickly stopping should occasion require.

**Relation of Powering to Capacity.**—It seems to have been a pretty generally recognized principle of machine design, prior to the advent of the high-speed era, that the massiveness and powering should increase proportionately to the capacity, or more precisely, the size of the piece the machine could accommodate. If there ever was any reason for this, there is none in the case of the new tools. Quite evidently a machine, say a lathe, required for working down a 4-inch bar, may be required to cut just as fast and to take as heavy a cut as if the bar were 12 inches or any other large diameter. The same gearing and powering obviously, then, are required for each. The exception of course is where the smaller machine is required for work which actually is lighter in character and which consumes less power. Even in such cases it is well to be on the safe side and to insist upon weight and power commensurate with that commonly found in the machine of larger capacity. The point is that the machine be capable of taking off and using continuously the largest amount of power that can be efficiently utilized by the tool.

**The Electric Drive.**—While the individual motor drive has many manifest advantages in ordinary practice, its efficiency is not necessarily superior in all sorts of machine operation. In high-speed cutting, however, the largely increased power consumption and the desirability, in general manufacturing, of quickly stopping and starting machines when changing the piece under operation, strongly emphasize the disadvantages of line shafting. The power lost in line transmission under ordinary conditions is very generally underestimated. Under the new conditions, wherein usually increased weight and speed is required in both shafting and belts, the losses are still greater and the individual

(or at any rate the group) machine drive comes nearer yielding a high efficiency, unless possibly in the case of small machines. Even in the latter case the group drive is preferable to line transmission of power. The method of applying the motor to the machine varies greatly, ranging from a separate motor at the ceiling, floor, or other convenient location, driving directly by a main belt or indirectly through a countershaft; to mounting it directly upon or building it around the main driving shaft of the machine. The latter is probably the most effective method of hitching, especially when the motor is of the multiple speed type; though the advantages of a chain drive through a variable speed countershaft

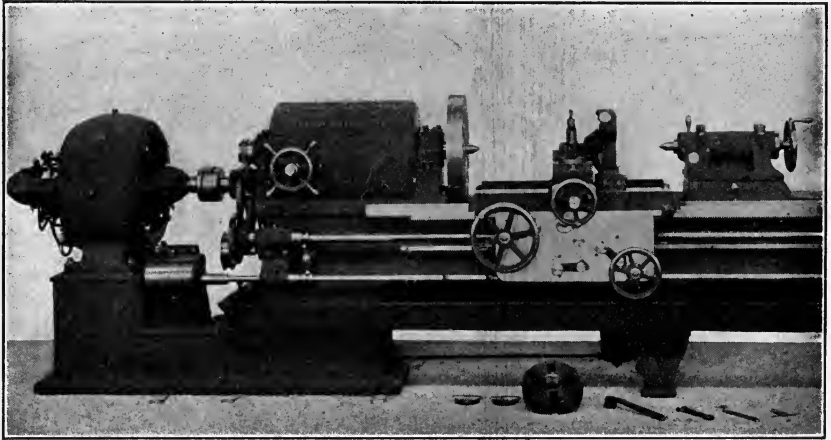

FIG. 252. A Lodge & Shipley high-speed lathe, direct motor connected.

or other device are to be considered where it is desirable to provide a great range of speed variations. The attachment of motors to machines through bracket extensions should be avoided.

**Use of Auxiliary Motors.**—A development of the motor drive which is of striking advantage, especially in big machines, in that it does away with a number of complications arising from effecting auxiliary movements through the main drive, is the employment of subsidiary motors for the latter purpose. Thus we have a lathe, Fig. 238, wherein the movement of the carriage is effected by a small motor, which latter also traverses the movable secondary headstock. Likewise a large planer, Fig. 254, is provided with as many as five separate motors. The main motor actuates the drive, a second elevates the crosstail, a third traverses the head and gives vertical movement to the tool, another operates the side heads, and so on. The simplification thus possible, and the convenience of operation, are ample justification for the innovation.

**Limitations of Reciprocating Machines.**—In wood working and the like operations, rotating tools or machines are about the only ones in use. There is everywhere a distinct tendency away from reciprocating

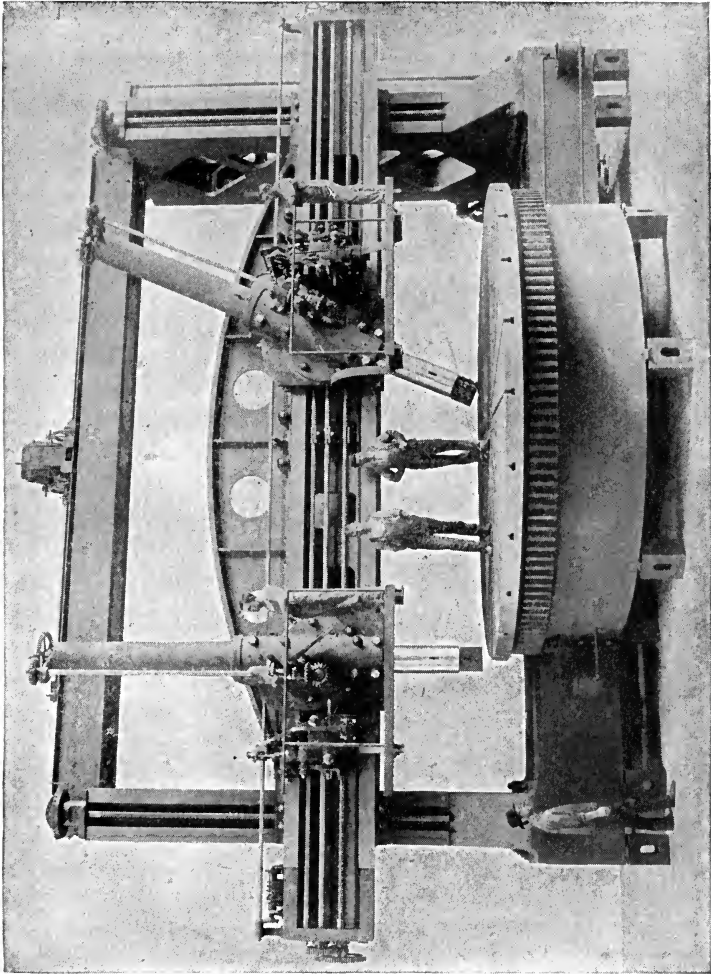

FIG. 253. Where a belt drive manifestly would be out of place. Auxiliary movements secured through small motors in addition to the motor for the main drive.

tools, with their great losses of energy through reversing, and toward the larger use of machine tools which rotate either the work or the tools. It doubtless will be a long time before the planer, the shaper and the slotter are entirely displaced by rotary planers and milling machines. The day is, however, being hastened by the apparent impossibility of designing or operating these types of machines to work at an effective speed approaching that of rotary tools. About the highest speed commercially practicable with a planer is about 60 feet per minute; and this is not attainable in general practice under normal conditions. If greater efficiency is to be attained it will doubtless be through the perfection of clutches and a modification of the method of changing the direction and rate of motion at the beginning and end of each stroke. Already progress has been made in this direction, and planing machines are now designed so that the tool starts into the work at a speed which does not damage either tool or machine, and is rapidly accelerated after entering the work to the maximum permissible in the operation of machines of this type.

**Taking Care of the Chips.**—When cutting speeds and feeds are moderate, taking care of the chips presents no difficulties to speak of. When,

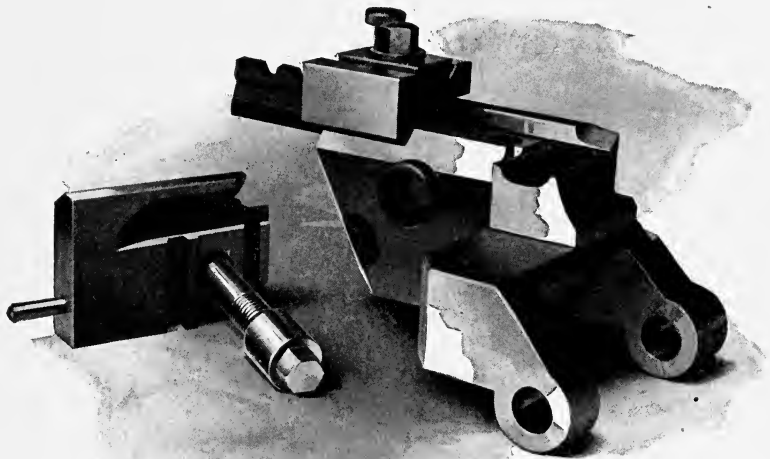

FIG. 254. Chip breaker (cover removed) as used on Hartness flat turret lathe. Taken by permission from "Machine Building for Profit," by James Hartness.

however, they come off so fast, as has been the case in certain instances, that the operator is obliged to exercise considerable agility and caution to avoid being entangled in and burned by the hot chips, or where it requires the services of two laborers to keep the machine clear enough of chips to permit effective operation, as was the case in a certain experience, the problem cannot be disregarded. Unless attention is given to it in machine (and tool) design, steel chips are liable not only to injure



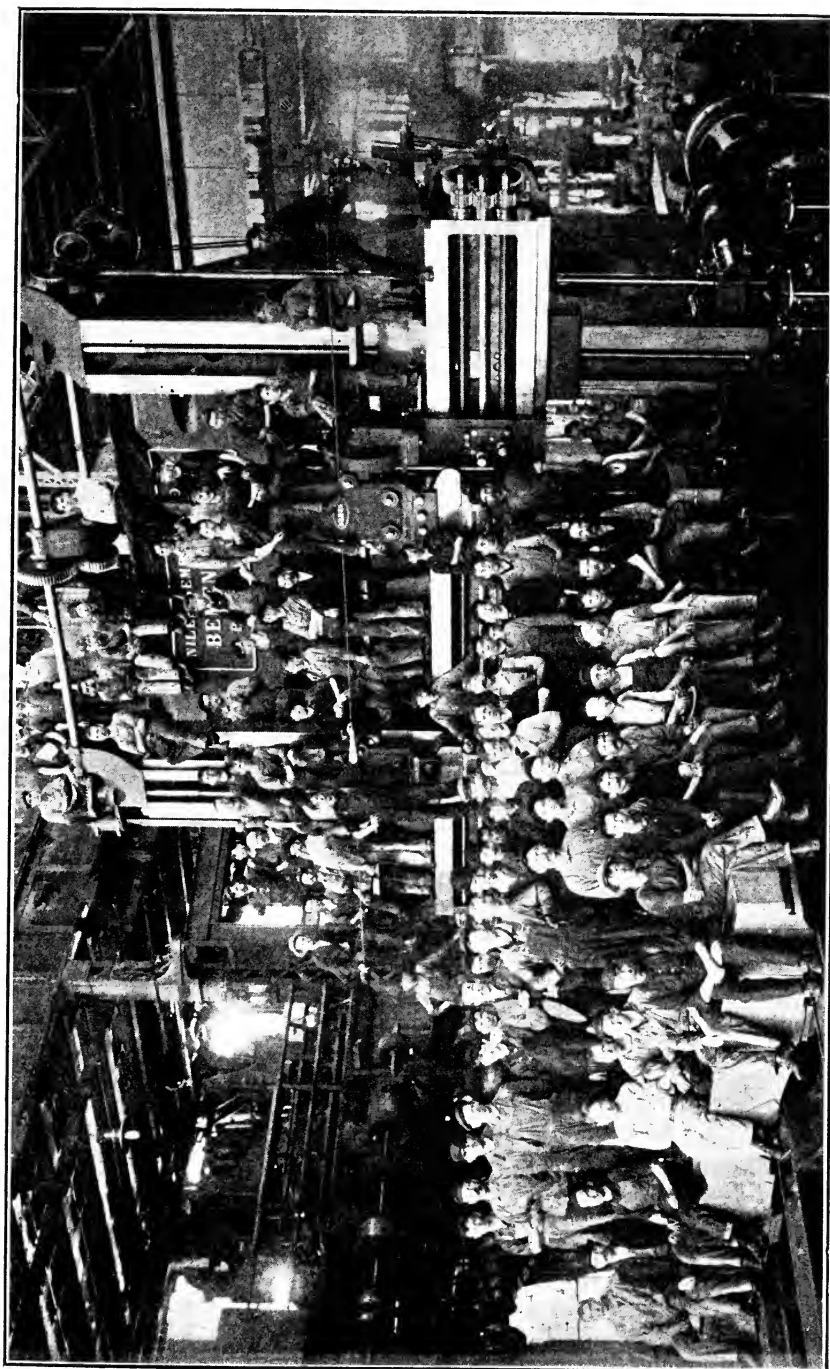

FIG. 255. An immensely large planing machine. Weight, 845,000 pounds. Five separate motors, with an aggregate of  $207\frac{1}{2}$  horse-power, operate this goliath, the main drive being by a 100 horse-power motor.

the operator, as in the extreme cases cited, but accumulate with such rapidity as to be otherwise troublesome. Most of the difficulty arises in the case of steel turning, by reason of the length of the curled chip. This feature is very simply cured by some device attached to the tool or tool post which bends the chip as it comes from the tool so it is broken into short lengths, say two to four inches each. An adjustable chute or other conveyor to carry away the short pieces is desirable.

**Summary.**—The remarks here made with reference to features in machine tool design desirable in connection with high speed steel tools, are applicable (except as specifically indicated to the contrary) to practically all types, whether used for turning, planing, milling, boring, drilling, or what not. The points to be emphasized may be summarized thus:

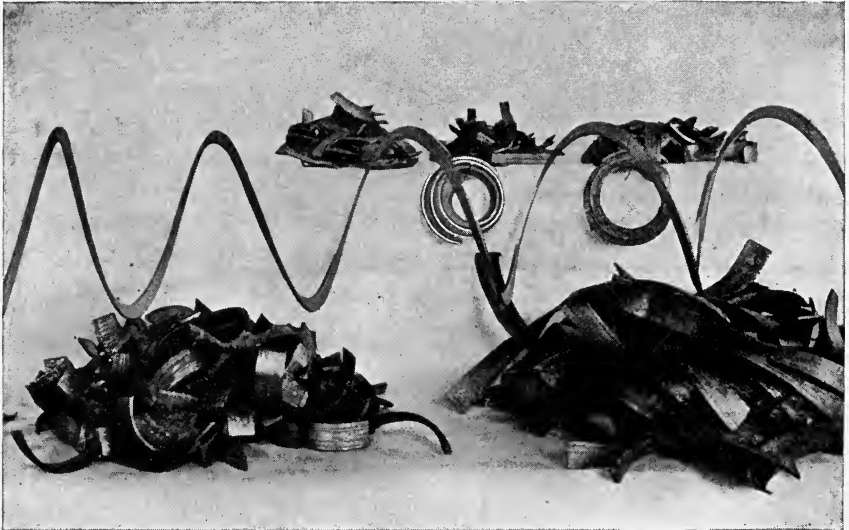

FIG. 256. Work of the chip breaker. The six groups of short chips were produced by a chip-breaking turner. The fine, curling chips were not run through the breaker. Taken by permission, from "Machine Building for Profit," by James Hartness.

Ample weight and distribution of material to insure the maximum of rigidity.

Elimination of all joints, movements and connections not absolutely essential to the kind of work to be done.

Locating tool as near the base (frame or bed) of the machine as possible.

Strengthening of main and subsidiary drives and substitution of positive powering for uncertain belts and step cones.

Reduction of speed changes to the minimum required in the special class of work demanded.

Direct individual motor drive wherever feasible.

Provision for taking care of chips.

## CHAPTER XIX.

### REMODELING AN OLD EQUIPMENT.

**To Scrap or to Remodel.**—A well-established canon of industrial engineering is that if a new machine will save its cost in five years, it should by all means be installed and the old scrapped. Not a few concerns make it a regular practice to supplant equipment, even when comparatively new, with other if a saving half as great can be shown. If this principle were to be closely followed in all establishments, there would now be a great amount of second-hand machinery easily obtainable. In many cases the saving to be effected by the new tools is insufficient to warrant scrapping existing installation. Under these conditions, and likewise where managerial conservatism or expediency in reference to capital required, make it necessary to use old machines with the new tools, it is important that some attention be given to the matter of remodeling them and bringing them into better condition to get good work out of the tools. Many a machine, in a general manufacturing shop at any rate, can by remodeling, or even by some minor changes, be brought into a high state of efficiency under the new conditions.

**A Case in Point.**—For example, a large capacity lathe, or rather one of large swing, is required to take light cuts only. Its weight, strength, and pulling capacity ordinarily will be quite sufficient for a very considerable increase in speed, with possibly a modification of the driving pulley; and by similarly changing the cones of the feed drive, or better by substituting gears, a considerable increase in feed traverse also is obtainable. Such a modification practically makes a high-speed machine of an ordinary one, adapted to the particular work mentioned, and is possible in a good many cases. When undertaken, however, it is important that the bearings be suitable to the new conditions. Otherwise it may be necessary to put an entire new driving head upon the machine.

**Simplification in Remodeling—Powering.**—Such a new head, or possibly a modification of housings and accessory parts in the case of machines of other types, must be designed not only with heavier bearings, but with provisions for lubrication both ample and certain. Unless this is done vibration and excessive wear, with the resultant chattering, are a natural consequence. Under the circumstances mentioned most machines now in use are stiff and solid enough to stand a mod-

erate amount of heavier duty, if the driving parts are made proportionately as effective. This is particularly true in the case of general manufacturing, where the work is mostly repetitive, the pieces of moderate length only, and the tools or work guided by jigs and other like devices. In such cases the re-designed driving parts can be very much

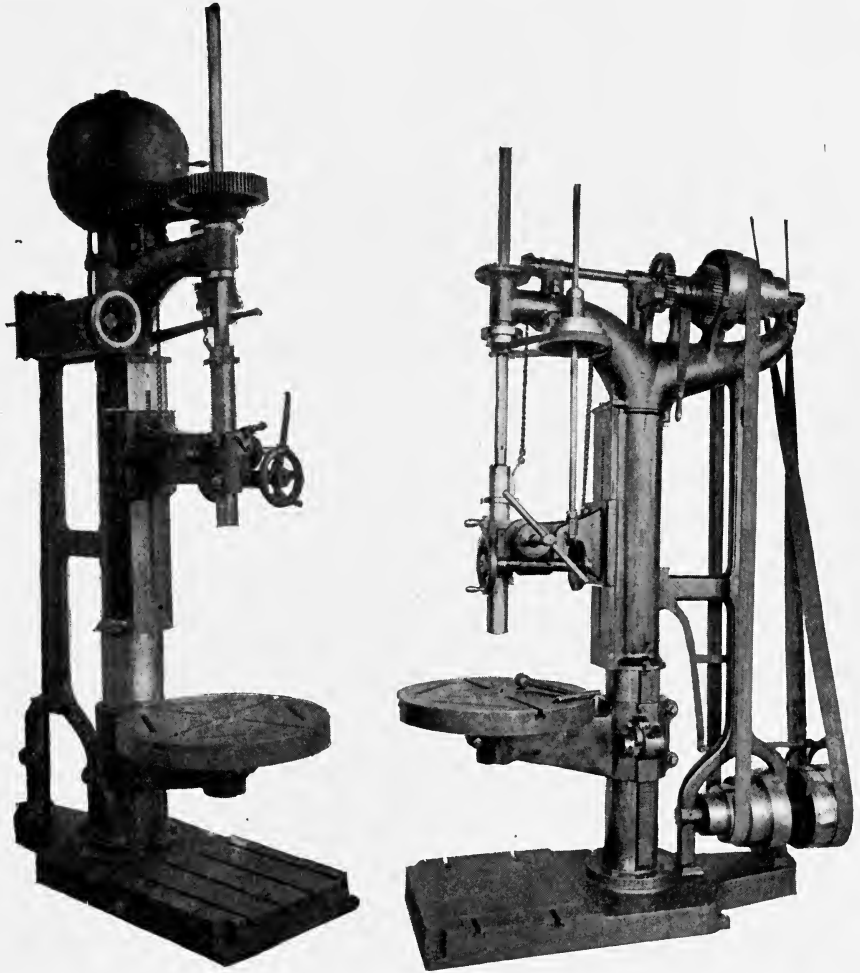

FIGS. 257 and 258. A drill press remodeled, to adapt it to high-speed drilling. Courtesy of Crocker-Wheeler Company.

simplified by the elimination of all superfluous speed gears and movements intended to give facility and convenience in miscellaneous work. The expense of thus remodeling a machine necessarily used in general jobbing is not infrequently prohibitive, and about the only thing that can then be done is to give a little increased speed and feed, to the limit of the machine's capacity; and perhaps to increase the driving power some-

what by the substitution of broader and larger driving cones. In the case of motor driven machines the motor should be, if it is not, capable of carrying overload sufficient to meet the requirements of the intermittent increase in its work.

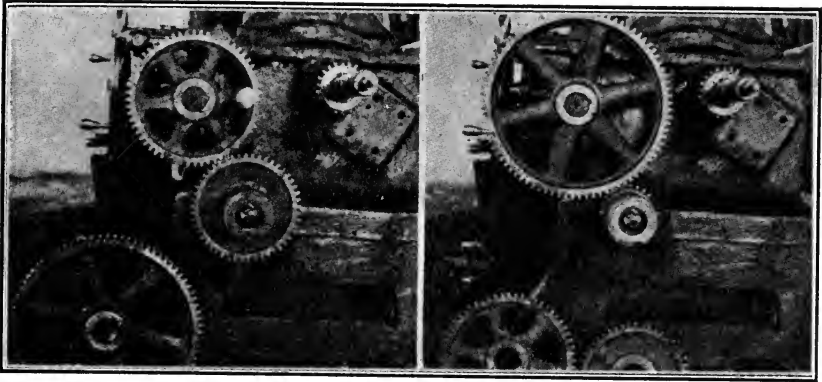

FIG. 259. Increase in size of feed gear on an old lathe. Due to increased feed possible with the new steels. One of many ways in which old machines may be rebuilt to meet the new conditions.

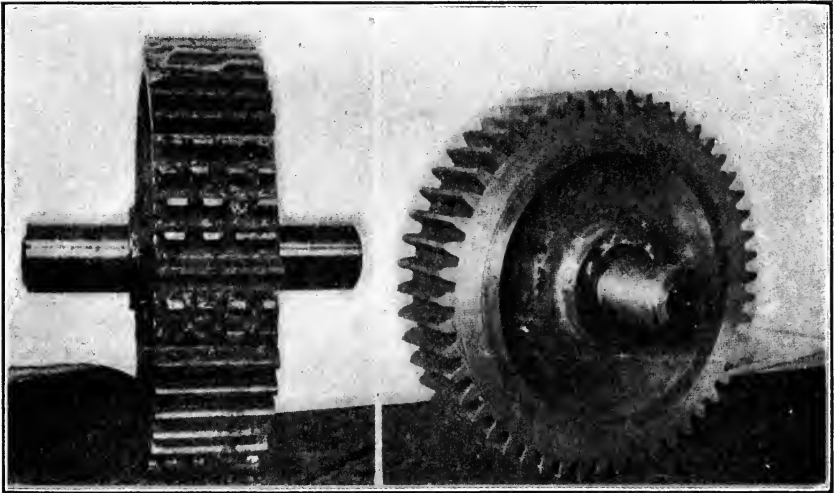

FIG. 260. Effect of increasing materially the pull upon a planer not designed for high-speed service, and a method of prevention. Steel gears are preferred, but in this case a steel rim was shrunk upon an iron hub as an emergency measure, and worked all right. Courtesy of Mr. H. W. Jacobs.

**Special Attention to Gears.**—In overhauling a machine with a view to use with high-speed tools it is essential that all gears should be replaced which are much worn or which are not both truly made and strong enough for the new service. In many cases it may be necessary to replace cast-iron gears with bronze or steel ones, or where they are large

enough to warrant, with steel rimmed (and preferably also steel or bronze bushed) wheels. Especially in reciprocating machines like planers, any large augmentation of the work done is likely to be accompanied by a stripping of gear teeth during the reverse and the starting of the tool into a fresh cut. The stopping and the sudden starting absorbs an amount of power frequently not suspected; and the momentum is greatly increased by the additional speed — where the design of the machine will permit such increase. To provide against stripping under these circumstances the gears must be strengthened as already indicated.

**Modification of Reciprocating Machines.**—Sometimes a machine of this reciprocating type, not otherwise capable of increased speed but strong enough to stand it, can be better adapted to the new tools by a re-designing of the driving apparatus and the use of clutches or the modification of those already in use. At the least it is usually possible to increase cuts, even if not speeds, through such modifications.

**As to Worn Machines.**—Concerning the many machines likely to be found in a shop devoted to general manufacturing, machines likely to have been in service for some time and therefore more or less worn, not much can be said without an understanding of the particular conditions. Often nothing is possible except to take advantage of the longer wear of a tool, that is, the less frequent need for grinding, while running at the usual speeds, though possibly with some increase in feed. In other cases it is possible, and therefore expedient, to run at the highest speeds possible without remodeling the machine, getting all possible out of it within the shortest time, then scrapping it when too much worn to work with sufficient precision and freedom from vibration.

**Spring in Frames.**—In machines like drills, and even planers, especially when the housings are considerably separated to allow large pieces to be worked, there is likely to be more or less spring in the rail or in the parts bringing the tool and the work together. This is bad enough when ordinary tools are used, and is the frequent cause of tool breakage, especially of drills; but if advantage is to be taken of the higher speeds and feeds often possible, attention must be given to so strengthening these parts or so supporting them that there shall be no spring. If the frame of such a drilling (or other) machine is weak, little, if anything, can be done. If the trouble lies in worn bearings for the brackets supporting the table, or to spring in them, they can usually be solidly blocked against the base and the proper degree of rigidity secured.

**Spindles and Tool Position.**—It should go without saying that worn spindles are not permissible in high-speed work; and if there is no provision for taking up the wear, they would better be replaced. The same thing is true of all studs and other bearings, and applies as well to all slides and adjustments. In many cases these need strengthening as

well as refitting, and usually also may be modified so as to bring the tool position nearer the supporting frame or bed and thus decrease the liability to chatter. All slides and adjustments not absolutely necessary should be eliminated and the tool holding and adjusting parts made as rigid as possible.

## CHAPTER XX.

### STATEMENT OF THE PROBLEM.

**Position of High-Speed Tools.**—Revolutions do not usually happen in a moment, in the industrial world. Perhaps it were better to say, they do not happen at all; for industrial progress is evolutionary rather than revolutionary. A new invention does not immediately upset prevailing conditions, but gradually takes its proper place as an economic factor while it is being developed and adapted to existing conditions — or as not infrequently happens, while conditions are changed to meet the new order made possible. So it has been in the case of high-speed steels. Their capabilities and limitations are by no means definitely fixed even yet, though they have already taken a place in production engineering important to a degree scarcely equalled by any other discovery in recent years. Along with improved methods of rapid transport and handling of materials, and of rational organization and administration, the new tools are surely, if not precipitately, bringing about a new order of things in the metal industries, and to a considerable extent also, indirectly, in other industries apparently not closely related.

**Cost Reduction as High as One-Third.**—A manufacturer of large interests is quoted as saying that in his plant the cost of producing machines has been reduced a fourth to a third, directly through the economies permitted by the use of high-speed steel tools and the indirect economies necessitated by the reorganization of the shop methods and shop administration. This may be an unusual case; perhaps it could not be duplicated in a manufacturing plant producing a greater variety of output. Perhaps also it is not possible in many cases (though parallel instances could be mentioned) to find, as in this one, that the labor-time on a single piece could be reduced as much as 95 per cent, the product being at the same time better than before.

**The Case of Tire Turning.**—The turning of locomotive drive wheel tires, to mention a case under different conditions, likewise is indicative of the wonderful development in metal cutting possibilities. Not so long ago one and a half to two days was the time commonly consumed in turning up a pair of drivers; and very recently indeed, the performance of the job in half a day, or a little less, was looked upon as a feat worthy of attention. Now, however, it is not only possible, but it is a regular commercial performance, to turn up badly worn tires as large



as five feet in diameter, at the rate of a dozen or so in a day of ten hours—the time required for placing and removing the wheels included.

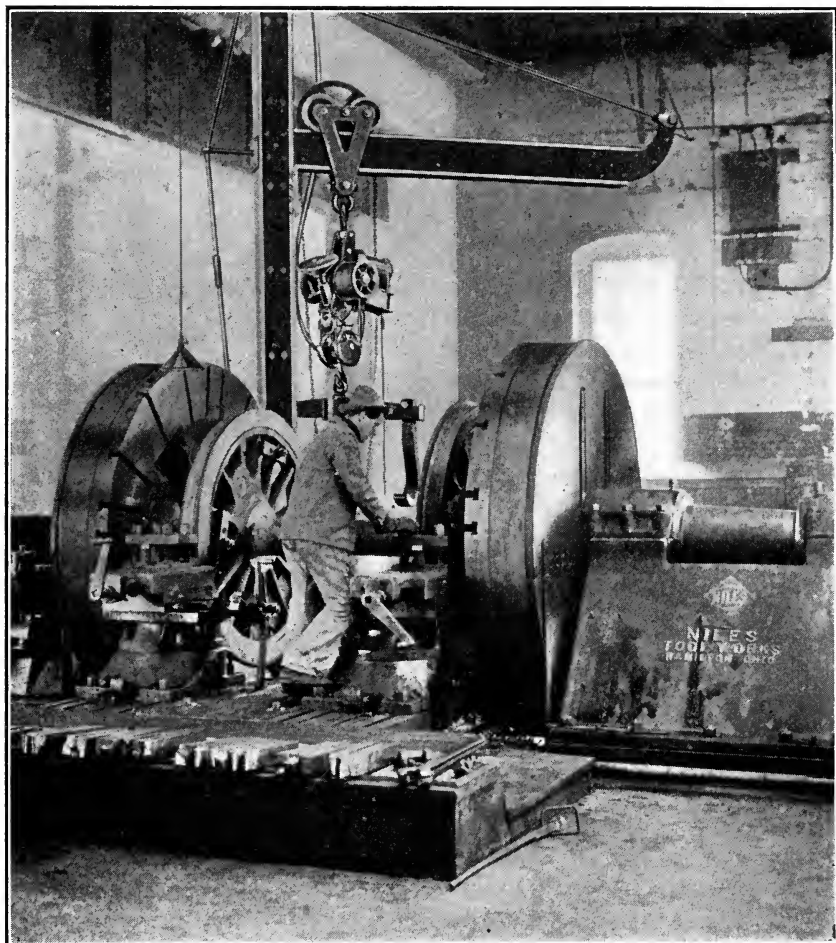

FIG. 261. Turning locomotive drivers at the rate of a dozen or more pairs a day necessitates facilities for rapid handling, as here shown.

**Astounding Economies not to be Expected.**—The publicity matter of high-speed steel makers and sellers sets forth in glowing terms examples of wonderful performances and astonishing savings effected. There is no need to question the accuracy of the instances cited. Doubtless even the most extravagant is capable of verification; and certainly none is likely to be more wonderful than those mentioned above, or than such as might be found in almost any average shop. Manifestly, however, such remarkable savings are not possible in all cases, nor perhaps even in many, considering the great diversity of conditions affecting

the different kinds of jobs in general manufacturing, and the differences in efficiencies everywhere existing. Indeed, the authority just quoted particularly mentions that in his own business of machine building, roughing work, in which he makes the greatest showings, does not exceed one-third of the work required, and that consequently a very large part of the saving is on this third part. It is not at all necessary that such showings should be common. The ordinary performances of the new tools, even under conditions allowing only moderate efficiency, are marvelous enough.

**A Modern Miracle.**—The possibility of cutting refractory metals almost as if they were cheese is another of the modern miracles — a miracle already become commonplace. Only recently cutting at something like 20 feet a minute was considered reasonably satisfactory; and this rate was probably above the average in most shops, though indeed speeds as high as 60 feet per minute were not unheard of, and some considerably higher than that are recorded as having been attained. So far as can be learned the maximum speed attained with carbon steel tools was about 100 feet per minute; and this was under the most favorable conditions of cooling and chip removal, conditions involving a complicated system of appliances and devices scarcely applicable to ordinary commercial work. Half as great a speed may well be considered to have been the commercial limit, under the old conditions — a limit not attained in practice to any considerable extent.

**The Passing of Traditional Conditions.**—Such speeds, or rather such extreme lack of speed, was in a sense distressing in an age where rapidity, time-saving, nerve-racking haste has come to be characteristic — where seconds count as hours did not in times within the memory of most of us. The days are past, or at any rate are swiftly passing, when it is the regular thing to see a piece of metal lazily creeping round and round, the tool paring it down at a snail's pace; the operator the while listlessly lounging near, merely keeping an eye upon the machine to see that all is going properly. And it is well that it should be so. Efficiency is come to be the watchword of modern civilization, and of industry the slogan. Hence the new tools, or possibly newer ones of still higher possibilities, must eventually crowd out the less efficient wherever efficiency counts, and must at the same time bring about very great concomitant changes in all the conditions touching or involved in the metal working arts.

But these changes are not yet accomplished, taking productive industry as a whole. They are only in process, and completed, relatively speaking, only in isolated industrial units. Hence it is worth while to inquire into the situation, not so much perhaps to discover why high speed steel tools are as yet used so little, comparatively, as to determine if possible what problems are to be solved, and how, in order to take the

fullest advantage of the new steels consistent with expediency. So much, at least, should be done in all cases. Only that ultra conservatism which spells bad management would permit less.

**Non-Uniformity of Material.**—A serious difficulty in not a few shops is that connected with the lack of uniformity in the hardness of the material to be machined—a difficulty which sooner or later is encountered in every shop. Castings every once in a while, for some unaccountable reason possibly, come so hard as to play havoc with ordinary tools. Occasionally the same thing happens with steel stock. Only a few pieces at most can be finished until the tool requires re-grinding. Possibly, in extreme cases, several grindings are necessary in order to finish a single piece. Or it may be the stock specified and required in a given part, is uniformly so hard as to be practically beyond ordinary tools—even mushet steel being able to make but a sorry showing. Instances of this sort are by no means infrequent; and there can be no question as to the expediency of using high-speed tools, even though there be no gain in speed or cut—as most often there may be, nevertheless. The gain here will certainly be great if only the loss of time in grinding and setting tools be taken into account; and it is likely to be considerably augmented by the saving which arises from the elimination of the need for scrapping many parts because of inaccuracy such as necessarily accompanies those conditions, when only carbon steel tools are available.

**Especial Field for High-Speed Tools.**—The especial field for high-speed steels, or rather the kind of work in which it shows up most favorably, is that involving the removal of large quantities of metal, as has been pointed out elsewhere. Here the Taylor doctrine of running tools (these having been suitably designed, standardized, and treated,) at speeds high enough and feeds and cuts heavy enough to necessitate re-grinding at intervals of about one and a half hours, can be practiced to the best advantage; and here it is that there is most reason for his dictum that the one who does not do so, does not know how to cut metals most efficiently.

**Scrapping not Generally Warranted.**—Saying nothing of the great variety of work where heavy cuts are not only unnecessary, but undesirable, and where the highest speeds are impracticable, it is to be observed that the conditions of maximum effect are dependent not alone upon the tools, but upon a considerable number of concomitants, the most important of which perhaps is the machine equipment. Obviously it is desirable that this latter should comport, in possibilities, with the tools as applied to the particular jobs. But average machines as heretofore used, and still in use for the most part, by no means measure up to this standard. In a few instances concerns have adopted the radical policy of replacing entirely all equipment not capable of using the new

tools to their maximum capacity, with other that is so capable. Clearly such a policy is in line with "good business" when the economies to be effected are great enough to warrant the expenditures. But in miscellaneous manufacturing it seems quite certain that they are not always so. Take for example that very large class of operations upon small pieces reduplicated in large numbers and generally requiring but little machining: The limit of the operator's endurance, and therefore the limit of output (except possibly through the adoption of an automatic machine — which is as yet impracticable in the vast majority of cases), has under these circumstances usually been reached.

**Place of the Automatic Machine.**—Of course if an automatic machine, or even a semi-automatic requiring a minimum of attention and skill from the operator or attendant, is feasible — which is to say, if such a machine can be built without being very complicated and expensive to maintain — the problem changes again, and it would be desirable to build the machine. But whether this be feasible or not in particular cases, there is a side to the high-speed problem often overlooked, in this very matter of the endurance limit of the operator and the related psychological and sociological effect of the deadening monotony involved in feeding stock into, and practically becoming an attachment of a machine. This is not deemed the place for a discussion of this aspect of the new-tool problem; but it is an aspect which will year by year become more insistent for solution and which must sooner or later be squarely faced. And when that situation arises, the indications now are that the increased development and use of the automatic machine, with its large possibilities in the way of high-speed tools, will be an important factor in the ultimate solution.

**Limitations Imposed.**—Not only is equipment wanting, in the great majority of cases, but expediency prevents the scrapping of machinery still in good, or even in moderately good condition, and the consequent large expenditures for new. On the other hand also there are a good many jobs where the inherent conditions are such that the machines in use are quite competent to do all, or nearly all, that would be possible in any machine — where the efficiency of a cutting tool is to a considerable extent limited by the nature of the job itself. Take, for example, the machining of a heavy casting, where the machining itself amounts to little and occupies but a small fraction of the total time necessary for the complete operation. Increased cutting speed manifestly would be of no considerable advantage; and neither would heavier feed; likewise there could be nothing gained by deeper cuts, except in special cases, for these would merely involve molding the casting larger than necessary, for the mere sake of removing it again. The special cases would be typified by that wherein it is required to mold the casting considerably heavier than the finished size in order to minimize distor-

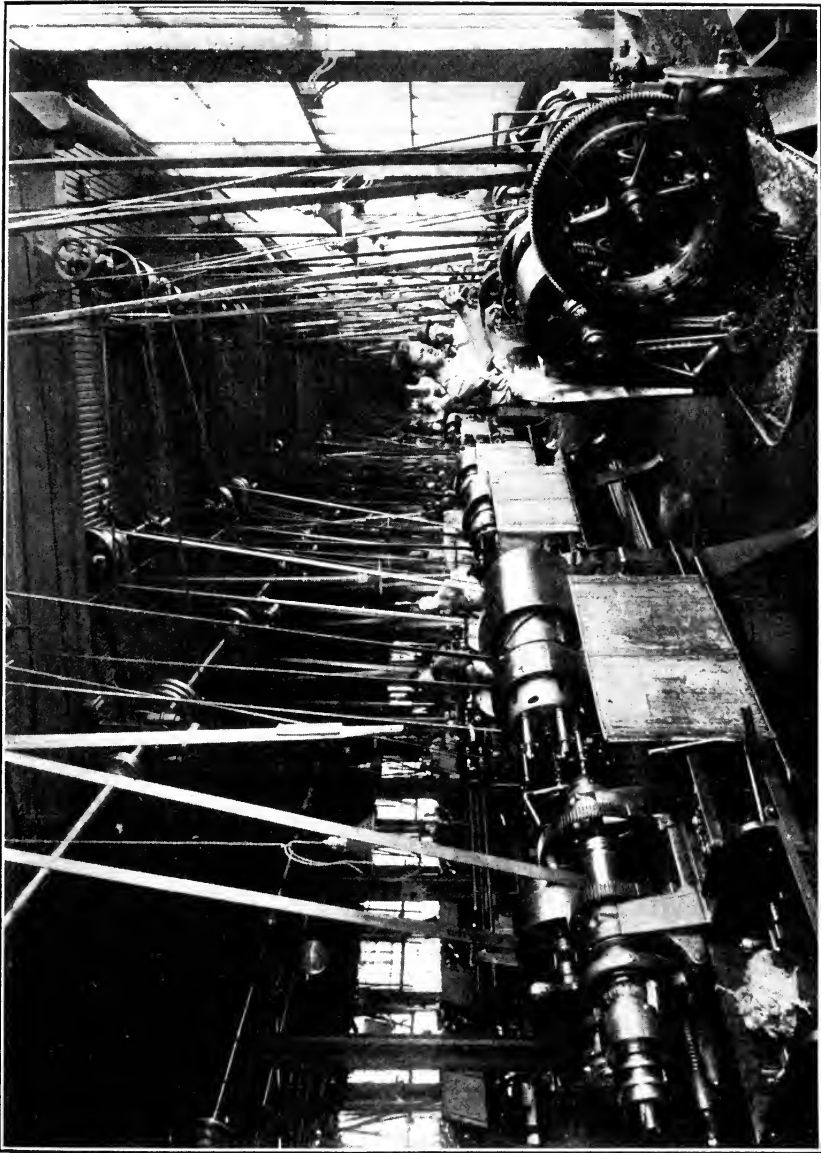

FIG. 262. The automatic machine will be an important factor in the solution of the psychological and physiological problems involved in rapid production. The need for tools having extreme endurance, so as not to require frequent stopping of the machines for changing or sharpening, is apparent.

tion or possible breakage during a series of operations, or where the nature of the casting partly chills the surface to be machined or leaves it with a skin naturally hard on a cutting tool. Here a deeper cut would be desirable; but the machines already installed generally would be quite able to take care of the increase required.

**Two Extreme Classes of Jobs.**—From jobs of these sorts it is a far cry to those at the other extreme where long and heavy cuts and high speeds are obviously the thing; and between these extremes lie jobs of all gradations as to cutting possibilities. Lying in the lower ranges would be those where the only economy in high-speed tools would be the lowered cost of tool and tool maintenance, and those where under prevailing or former conditions many pieces were necessarily scrapped because of breakage or imperfect workmanship. The apparent paradox of cheaper tools is touched on elsewhere, but may be said here to refer to the relatively long life of such tools, the more particularly of composite tools, and the consequent distribution of tool cost over a very greatly increased product. The scrapping of many pieces which has seemed necessary to and inherent in tools and methods heretofore in use, can be eliminated to a material extent through the use of high-speed tools, in most instances without any change in machines. Such a saving may easily be considerable while still not appearing in a changed labor rate.

**Operations with Short Cutting Times.**—Referring again to jobs such as have just been mentioned, where the cutting time is relatively small: there may be many such where it is quite possible to use higher speeds or heavier feeds to such an extent that the cutting time becomes negligible, or nearly so; and thus the second or third machine which is under present, or was in recent practice necessary to keep the operator busy, can be dispensed with and capital (and consequently depreciation, repairs, etc.) thereby reduced while at the same time available floor space is increased. Here also there would be a saving quite appreciable, which nevertheless would, under usual methods of cost accounting, not appear in labor cost — a saving which might, or might not, necessitate the installation of a heavier machine, according to the conditions in particular cases.

**Immediate and Ultimate Considerations.**—Evidently the problem is by no means, or at any rate not at all necessarily, one of disposing of old and installing new equipment throughout an average plant. Unquestionably high-speed steels, if the standing offer of certain makers to replace with positive economy any ordinary tool with one of their own make can be backed up, are bound ultimately to displace almost, if not quite entirely, the less efficient kinds. Even now it is not so often a question as to whether or not a high-speed tool shall be used, but rather as to expediency in reference to the equipment in which the tools must be

operated. Ultimately of course the question of profitableness will determine, as it does practically all questions in industrial engineering; and if, when all is said and done, a new tool or a new machine, or both in conjunction, will yield a product cheaper and better than before, then the old must inevitably give way to the new sooner or later — and usually sooner than later. For the present, however, the problem, in so far as it concerns the shop or factory in general rather than those special cases already indicated, seems to be less a general than a specific one. In an offhand way it may be said with assurance, almost as a matter of course, that high-speed tools should be used to the largest possible extent in all metal-cutting shops. But the real question is, just what shall be done in this or that specific, particular instance?

**How the Problem Works Out.**—Here is a job, let us say, to be performed under definite conditions; and such and such machines are available for, or possibly are actually performing, the operations. Is it possible to reduce the cost of these operations, or specifically this one operation, by the use of a high-speed tool and heavier or faster cutting? If so, to what extent are the available machines capable of realizing the ideal conditions, if utilized without modification? If this performance falls short of the attainable maximum, can the machine be altered or rebuilt, without prohibitive cost, so as to yield this maximum while still not working disaster upon the machine and wiping out the gain through heavily increased maintenance cost? This latter point is one seriously to be considered, in connection with the subject of equipment in general, as well as in connection with specific cases. It is found possible to speed up a machine still quite serviceable under ordinary conditions, so as to yield a considerably larger output; but directly it may be found also that gears break frequently, and belting gives out rapidly, and the expense of repairs in general is possibly as much as doubled. This of course does not always take place; but it may do so, and is frequently to be expected. The limit of the machine's endurance, that is, the point beyond which maintenance cost becomes excessive and expensive delays through breakdowns are invited, is carefully to be considered; and along with it the rapid wear under the severe conditions for the meeting of which it was not designed.

**The Power Problem to Receive Attention.**—Furthermore, the matter of power consumption needs attention. Not that the increased amount of energy required for taking care of the greater amount of work done need occasion serious concern. Under proper conditions the total power required for doing a given amount of metal working will actually be less than under old conditions, though indeed it becomes necessary to concentrate or localize it largely, so to speak. In attempting to speed up old machines designed only for moderate speeds, the amount of power absorbed by the machine itself, not considering at all that

entering into the cutting, may easily become surprising. It is not so unusual as might be supposed in the absence of actual measurements, for a half of the total power delivered to a machine to be thus absorbed in overcoming friction. Under such circumstances the speeding up of a whole plant would evidently necessitate a very large augmentation of power plant capacity.

**When a Machine is to be Superseded.**—When it is evident that a machine already installed cannot economically or effectively meet the desired requirements, the question arises as to the displacement of the machine with one capable of yielding the maximum output with minimum maintenance and operating cost. Questions of temporary expediency aside, there are pretty definite conditions, though varied according to the nature of the individual cases, under which a new machine should replace an old. Quite plainly if the required output involving a particular job or a closely related class of jobs is sufficient to keep the machine busy practically all the time, and the required increase in output must be met by additional equipment anyway, it is then not only desirable to install an up-to-date machine, which by its increased efficiency will be able to take care of the required increment, and probably more; but it is folly not to do so. Even though the machine be idle a considerable portion of the time under the new conditions, the economy is like to be more than great enough to warrant the change; and the same often will be found true when even the old machine is not used nearly to its capacity. The common rule that a machine is to be replaced whenever a yearly saving or ten to twenty per cent of its cost can be shown, has been referred to already. In the consideration of such changes it is to be remembered that a machine not sufficiently productive or powerful to allow efficient use upon one job or class of jobs, may still be suited to economical work upon another whose requirements are less rigid; so that the displacement of a machine is not necessarily the same as scrapping it.

**Re-design of Jigs, etc.**—Not only must the machine be capable of, and adapted, so far as may be, to heavier duty, generally speaking, but especially in reduplicative work jigs and other holding or guiding devices will need re-designing or remodeling. Magnetic or air chucks and jigs will largely displace the cumbersome lug or screw fastened holders still generally used, so that a piece of work, or a number of pieces simultaneously, can be instantly fastened securely and held firmly during the operation, and as quickly released when the job is completed. Likewise it will be necessary to devise something more substantial for holding work turning on centers than the bent tail dog, whose wagging is not tolerable under the new conditions.

**Manufacture or Purchase of Tools.**—Intelligent production and handling of the tools is a factor in high-speed production second in importance



to none other. The actual making of tools is best not undertaken at first, except perhaps in large plants. They can be readily purchased made up to specifications fitting them for the particular work required.

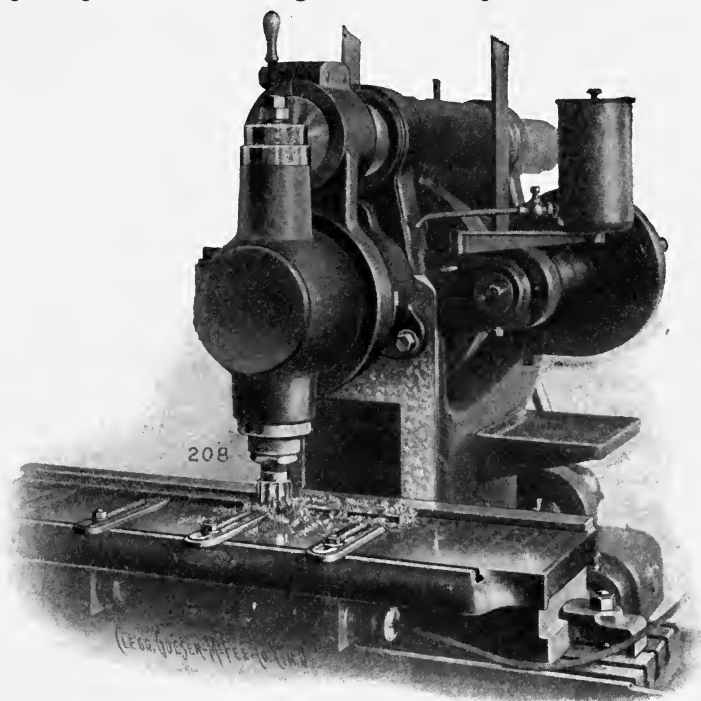

FIG. 263. End milling. Use of magnetic chuck for quickly clamping and securely holding work. Courtesy Cincinnati Milling Machine Company.

The purchase of all standard tools will be most economical, in general, for all shops except possibly those especially equipped for their manufacture, though it may well be that such simpler forms as lathe tools and the like can be produced within the plant itself. Even this is not advisable unless there be suitable facilities and tool-makers expert enough to make tools of uniform and high standard quality. Experiences with tools manufactured under uncertain conditions and by inexperienced hands, and therefore of uncertain quality and uniformity, are likely to prove unsatisfactory and disappointing. In the beginning, at least, it is safest to buy all tools ready made, gradually training tool-makers to the proper handling of the new steels and substituting for those made outside only as experience shows the possibility of producing within the shop others equally certain in quality. An alternative of course is the employment of one or more experts to undertake the tool-making problem, and in large shops to train the rest of the tool makers to the new tricks of the new trade, so to speak. Unquestionably this is

an excellent thing to do anyway, in places where many tools are manufactured; and even then it will be no day's task to educate men brought up under the old conditions to the new requirements in tool making.

**Expert Direction.**—Such an expert might have charge also of the development of the high speed steel problem throughout the plant, with a large responsibility in the matter of educating the machine operatives also, to the new situation. The old proverb holds good in industry as elsewhere — it is hard to teach an old dog new tricks; and it takes time and not a little persistence to educate a man out of the 25 foot speed and  $\frac{1}{32}$  inch feed rut and induce him to take advantage habitually of cutting rates three and more times those to which he has been accustomed, even if he be willing to learn. The new tools can do much; but they cannot make an industrious workman of a lazy one — any more than they can increase the physical endurance of one already pushed to the limit under the old conditions. Where this limit is reached, as shown before, an entire change in the method of doing the work — perhaps by the substitution of automatic machinery — is the obvious thing to do. If not, it is desirable that the hearty co-operation of the workmen be secured.

**Attitude of Operatives.**—Not that operatives in general do not take kindly to the new tools. On the other hand they all but invariably welcome and eagerly desire to be permitted to use them. But it not only requires an expert knowledge of conditions and of the possibilities of the individual cases so to set the pace or change conditions that the highest attainable efficiency shall be insured; but also it is essential that there be held out, through a rational and just wage system, like the premium plan, say, such incentive as will stimulate ambitious workmen to raise their own efficiency; and that at the same time there be supervision so skilled and so organized that guesswork in machine operation is minimized or entirely eliminated, and conditions hindering maximum efficiency changed so as not only to permit but to compel it.

**Maximum Production—Auxiliary Conditions.**—Precisely here it is that a great mistake is often made in high speed tool practice. The subject has scarcely yet been approached, much less reduced to definite standards fitting all cases. It is true that Mr. Taylor and his associates have succeeded in reducing practice in certain works to a very definite basis; and they have obtained results nothing short of phenomenal. Equipment, tools, auxiliary methods, and even administration, have been revolutionized to create conditions making for greatest efficiency; and everything (or almost everything, it would seem) is definitely and specifically worked out by the slide rule, and by effective supervision the standards thus set are actually attained and maintained. All this goes to show, as do similar experiences elsewhere (possibly carried out less consistently), that the problem of high-speed tools involves not only

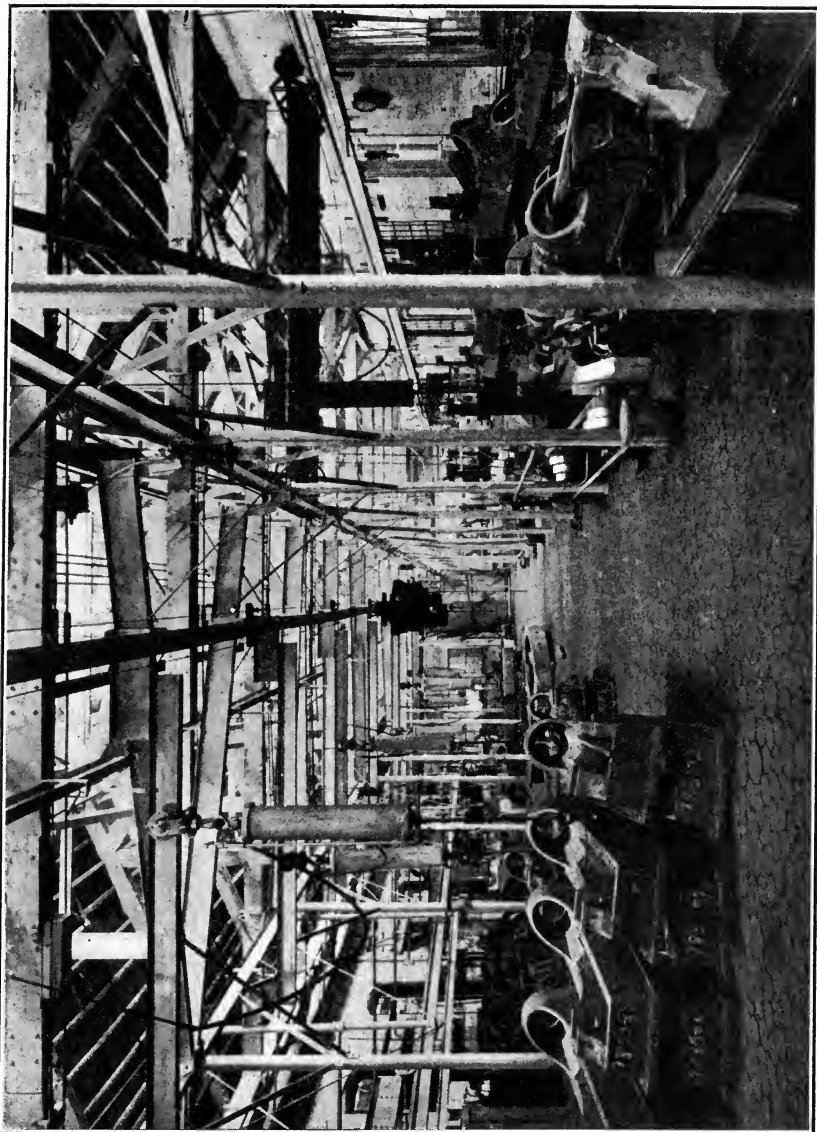

FIG. 264. The rapid handling and flow of material is an essential condition for obtaining largest return with high-speed tools. Here we have a trolley system equipped with air hoists, reaching every machine in the shop, related closely to traveling cranes and also (outside the building) with the industrial railway system.

the matter of tools and machines, but is vitally concerned with the subject of shop organization and necessitates methods of supervision and co-ordination very much in advance of those customarily in vogue. It is important, that is, not only to determine beforehand with practical accuracy the machine to be used for a particular job, and the most efficient speed, feed and cut, and the precise manner and order of doing the work; but for profiting to the largest extent by this possible acceleration, the movements of material, the facilities for storage, the supply of sharp tools and the method of distributing them — all these and

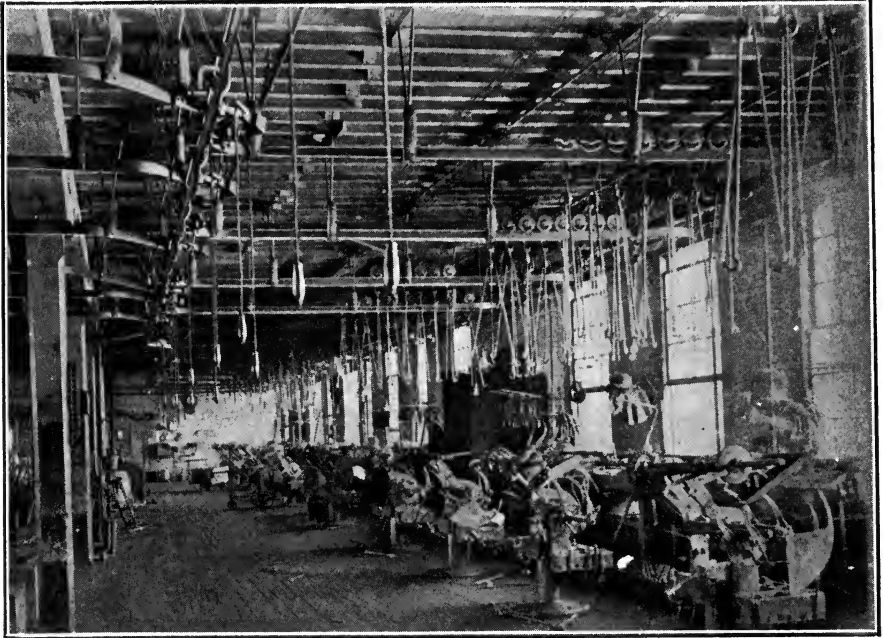

FIG. 265. Auxiliary storage for materials in process requires much space around the machine or involves the large use of conveying or transportation units, as in the case of this overhead trolley system. From the main trolley track switches run to every erecting jack in the room. The assembled machine is tipped from the jack onto the hooks of the trolley, shunted out upon the main track, and propelled to the paint shop by a motor-actuated endless chain provided with suitable fingers.

other ancillary activities, systems, and methods concerned in the conversion of material into product, may need, and probably will require, entire reorganization. Thus, concretely, it boots little that an industrious and ambitious workman be provided with the most approved superior rapid-cutting tools operated in the most up-to-date machine, the most efficient rates of cutting carefully prescribed, and working under a rational premium or other wage system urging him on to the exertion of his maximum efficiency, if at the same time he is obliged at intervals to loaf or dawdle along while waiting for material, because of inadequate means of transporting and handling the same to and from

his place of work, insufficiency of stock or of storage facilities for material, or a stinted supply of sharp tools.

**Material Handling—Change in Methods.**—More than likely accelerated production under the new conditions will mean, in most factories, a complete change in the methods and facilities for stock storage, the providing of more room and better access so as to permit handling to and from storage with the greatest convenience and ease. Heavy parts, as well as light, will need to be so stored, and means for mechanical handling so provided, wherever necessary, that the movement and

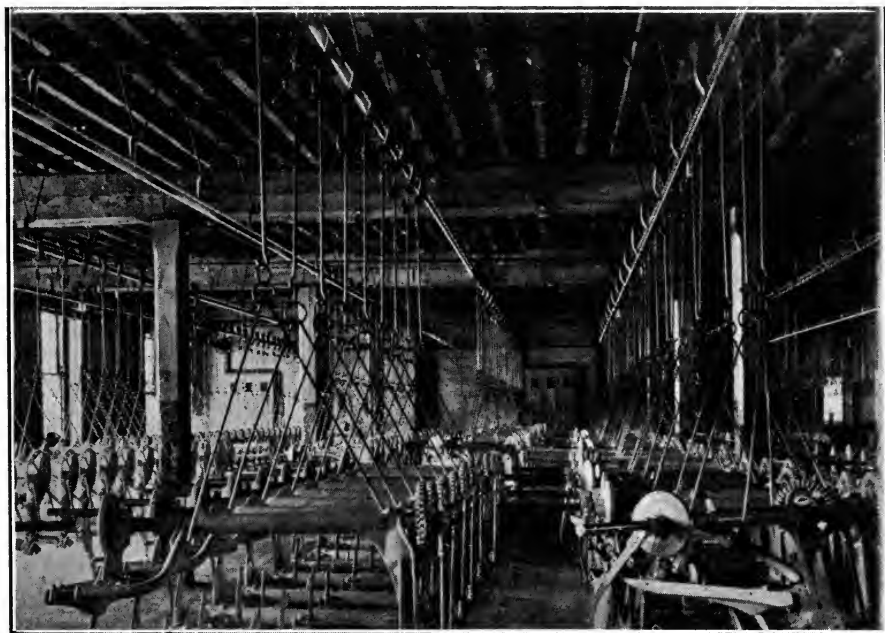

FIG. 266. After passing the dipping tank the trolley and its load are switched from the trunk track to storage tracks for drying.

handling shall involve a minimum of effort, of time-labor. The subject of auxiliary storage, storage for material in process of manufacture while passing from one operation to another, becomes highly important. More room will be required around a rapid production machine than ever before; but not necessarily for storage bins. These may well be required; but if so, ought to be of such type that they can be emptied into transports of appropriate sort with practically no handling, or to be so placed as to permit their being reached without any transport, by the operator to whom the parts next pass.

**Auxiliary Storage and Transportation.**—The auxiliary storage will most likely need to consist mainly in a very materially increased number

of transport units — cars, trucks, trolleys, or whatever such units may most conveniently consist of, to meet the requirements of the particular kinds of parts to be transported. Hand trucks, of approved types only, may perhaps still be used, in larger numbers than ever before; but the relative inefficiency of man power, as compared with mechanical, indi-



FIG. 267. Auxiliary storage by hand trucks. Very well if trucks are designed to fit the conditions and do not occupy an amount of space not permissible.

icates the need for displacing hand trucks to the largest possible extent by conveying units capable of being mechanically moved. The transportation system therefore will need overhauling and remodeling, with a probable large increase in capacity and a close interrelation of the various constituents. The standard gage and industrial railway, the crane service, the overhead trolleys, belt and other mechanical conveyors, and also hand trucks where these are retained, must be so interrelated and efficiently operated that material will move rapidly, without unnecessary interruption, and in sufficient quantity always to insure a minimum

of lost time at the machines as well as while in actual transport. The desideratum will be rapidity of movement as well as ample sufficiency of portable storage capacity (the elimination so far as practicable of man-power trucks being taken for granted), so the material can pass along through the several processes of manufacture with least loss of time and the fewest number of handlings.

**Problem of the Tool Room.**—The tool-room problem likewise assumes a place more important than before. It is necessary that the supply of tools be ample, which is to say, much larger than under old conditions; but the system of stocking and distributing must be greatly improved. Red tape will be eliminated so far as possible, and provision made whereby the workman can quickly communicate his tool needs and have them quickly supplied. This may mean electrical communication in connection with mechanical or pneumatic carriers, or perhaps the latter alone. In plants where the highest organization is for any reason impossible, it may mean electrical communication of some simple sort, in connection with boy-transportation of tools. But at any rate it means a change from present methods, as usually found, to others more in harmony with the spirit of accelerated production.

**Tool Supply and Maintenance.**—This phase of the problem (the tool supply) is concerned also with questions affecting the length of time it is expedient to run tools in particular cases before re-grinding, which in turn is related to that of standard speeds and feeds; and may mean the revolutionizing of the system and methods of sharpening tools. This latter evidently will need to be done by inexpensive labor, in grinders designed to operate with precision to give standard shape to cutting edges with minimum skill, and involves the adoption of a complete system of standards and specifications with respect to tool shapes. It likewise involves such storage facilities for tools that they will be least likely to sustain damage (nicked cutting edges, and the like) in the storeroom, and can be dispatched and delivered with promptness. There come in also such matters as more complete standardization and interchangeability of the parts manufactured, where this is not already carried as far as possible; and the maximum use of gages requiring a minimum of time and skill to use, even where jigs can be used most largely.

**The Array of Problems.**—Such an array of intimately related problems, all affecting the most efficient use of the new tools, may well lead to hesitation in the adoption of high-speed steel as the standard tool material. It may seem in some cases to involve an entire reorganization and more or less re-equipment of the whole factory, and at the least a wide departure from existing conditions. As long as it will pay increased returns to both factory owner and worker, clearly the new *should* displace the old. Gradually, of course; for revolutions such as these, as pointed out in the beginning, must take place naturally, else the whole business is like to



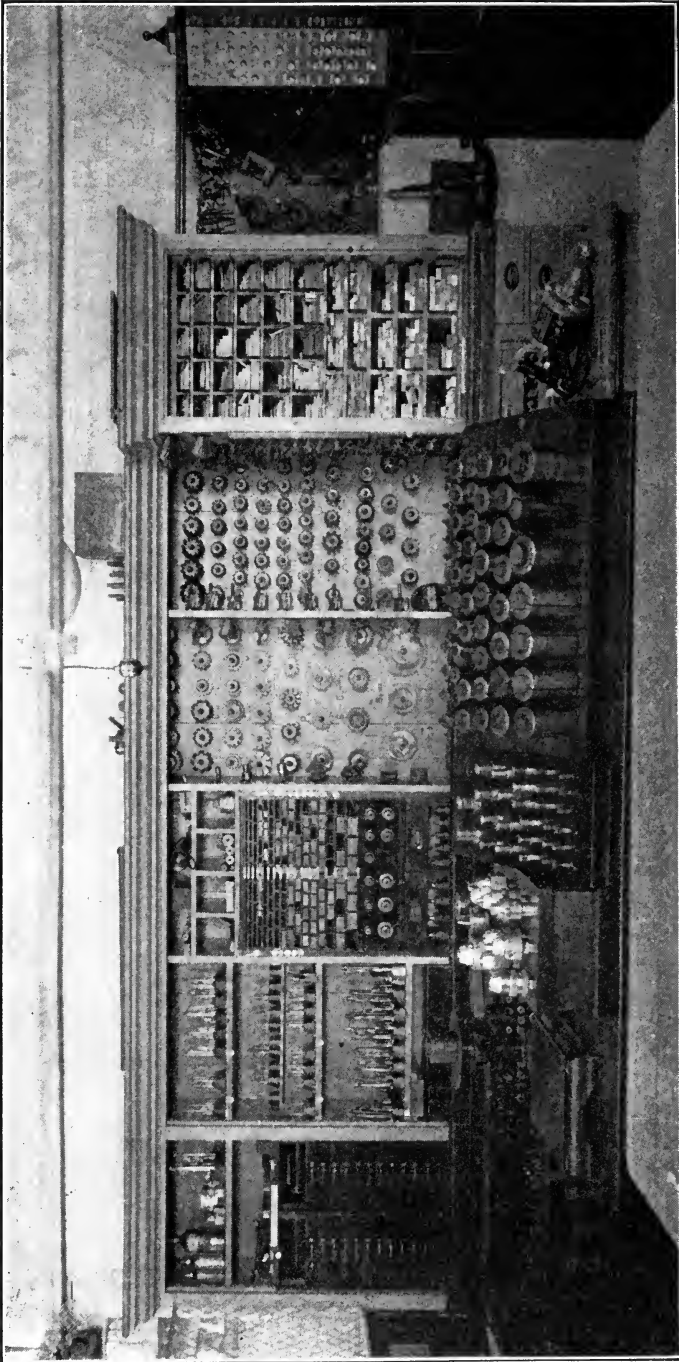

FIG. 268. The tool supply and stores problem is one of major importance under the new conditions. Storage facilities must provide not only for an ample supply, but against the possibility of damage to the keen-edged tools.



be put out of joint. And ultimately the change must come, willy-nilly, even to the most conservatively managed shop. So long as competition shall be the basis of business, ever growing keener as it must, the law of survival of the fittest will eliminate from that competition any business which neglects to take advantage of every opportunity for increased and more economical production, such as is offered in the metal industries by the extensive use of high-speed steel.

**Expert Assistance Desirable.**—And who is sufficient for all these things? The factory manager as he is, and his force of lieutenants, possibly may not feel equal to such a reorganization, and probably also are in no position to give attention to the working out of all the details. The employment of an expert to take charge of this part of the situation has been already suggested. Experienced engineers stand ready to undertake just such commissions; and it is merely a matter of time and capital to bring any plant to the highest possible state of efficiency. The lack of the latter item, sufficiency of capital, will of course delay the complete carrying out of plans for maximum productive capacity at minimum cost in a good many instances, but should by no means delay the undertaking and its accomplishment as rapidly as circumstances will permit.

**The Situation Summed Up.**—Summing up the situation as it confronts the factory manager, it seems to be about like this:

Old tools are to be displaced wherever it can be shown that the time saved in grinding and the tool cost per piece finished, even if there be no gain in rapidity of operation, shows a substantial saving. The new processes of manufacturing composite or compound tools reduce the cost to such an extent that the difference between their first cost even, and that of the old kinds, is not great enough to be seriously considered; and not infrequently actually allow tools to be made cheaper than before.

Old machines can be utilized in many cases almost or quite as efficiently as new ones, in the general run of manufacturing; and when not, can often be remodeled to a greater or less extent, as the conditions in the case warrant, so as to be moderately well suited to the new requirements. In many cases the old machines will be unsuited to the heavier duty necessary, and will need to be displaced by new, of types designed with the special conditions in view. Such new machines, in general manufacturing involving the reduplication of parts, will be as simple as possible in construction, with all unnecessary movements and adjustments eliminated. For shops producing mainly such things as require or permit the removal of large weights of metal, machines of extraordinary strength and power will be required.

The workman himself is an important factor in securing the largest returns from the new tools, and his co-operation is to be secured through a liberal wage system whereby he, as well as his employer, profits; and

his work is to be so adjusted that when working at maximum efficiency his physical strength and endurance are not overtaxed.

The tool department will need to be carefully adjusted to the new conditions, the tools themselves being made within the shop or purchased outside, as may be most expedient. In the former case it is absolutely essential that there be expert toolmakers who shall be able to turn out tools of the very best quality, and in the latter case it is important that the tools be bought according to specifications fitting them to the special work required of them. The distribution of tools, and their grinding and keeping in condition, will be so organized that the workman himself is relieved of the need for attending to the matter, while promptly supplied as his needs may require.

Transportation and storage facilities, especially auxiliary storage for materials in process, must be adapted to the accelerated production, and so co-ordinated as to eliminate all unnecessary handling and all delays occasioning idle machines and workmen. The transportation system will have its units so adapted and of such number that they will in large part serve for the auxiliary storage. Stationary storage, whether for stock or material in process, is to be in such form as to eliminate handling as far as may be, and to facilitate handling where this is necessary.

And finally, supervision of the highest order of intelligence, as applied to the special problems involved in the use of the new tools, is indispensable. It is necessary to determine beforehand what shall be the time and method of doing given jobs, fixing these elements and the labor cost at the same time, on a rational basis instead of by guess; and likewise to see to it that the conditions laid down are faithfully carried out. Such special supervision may be trained up within the plant itself; but in general it will save time and insure greater efficiency if the reorganization be done through some outside agency, say through industrial engineers thoroughly familiar with the new conditions.

## CHAPTER XXI.

### MAKING A BEGINNING.

**About Tests.**—About the first thing considered ordinarily, after it has been decided to use high-speed tools, is the making of tests to determine the best steel for the purpose. Much good money is wasted in this way, and not a few disappointments grow out of such misdirected zeal. Not that all such tests are useless. They have their place — which, however, is not at the beginning of one's high speed tool experience. There are on the market a great number of the new steels, possibly more than a hundred by this time; and while they vary more or less among themselves as to composition, and therefore as to special adaptation and universality of use, almost any one of them put forth by a manufacturer of repute will do as well as another while a beginning is being made and the local problems investigated. In the meantime the simpler, as well as the better way, is to select some one standard make of steel, and use it exclusively until there shall have been sufficient experience in the making and use of the new tools to permit intelligent experimentation and rational conclusions. Besides the small value to be placed on tests conducted by neophytes, or even by experts, for that matter, under conditions not thoroughly understood, there are several manifest disadvantages in keeping on hand a supply of each of several kinds of steel, and making or using several kinds of tools for the same work. All these difficulties and disadvantages are avoided if, as suggested, but one make of steel is selected. Obviously the selection must be made with some care, so as to make it reasonably certain that the steel adopted for the time being shall be well adapted to the general run of work done in the shop. It may be mentioned in passing that cheap high-speed steels are to be looked upon with suspicion — at this early stage of experience at any rate.

**Scope of Profitable Experimentation.**—Neither is it worth while to undertake expensive and long drawn out experiments (others would be of small value) to determine cutting angles, tool shapes, standard speeds, and the like data of a general nature, as a basis for the introduction of high-speed tools. It may be possible to improve upon the determinations already made by others, or possibly to modify now accepted conclusions; but experiments looking toward this end may well be left until later in one's experience, and the laws and facts already established and avail-

able for reference adopted for use until mayhap better can be found in the natural course of events.

It may be said in passing that to carry on a series of experiments such as these, so the results will have positive value, requires much experience and clear thinking, and involves a preliminary arrangement of conditions not always easy to secure. Thus, to mention a single point, in testing one steel against another, the results will be of little value unless the tests be made at the same time, on the same piece of work or on pieces ascertained beyond doubt to be of exactly the same characteristics as to hardness, etc., with the same feed, speed, and cut, on the same diameter, with tools of precisely the same form and treated so as to develop the maximum possibilities of each — which treatment may perhaps not be exactly the same for both tools. If allowance has to be made for variation in any one of these conditions, the comparative values cannot be established with certainty. The introduction once made and the new methods once fairly established, the workmen educated to the proper management and use of the new tools, there will be time enough to carry out any such comparative tests as may be found desirable. Especially if it is attempted to manufacture all, or perhaps but a few, of the tools, even under the direction of experts familiar with the new steels, there undoubtedly will be enough troubles and problems without the additional distractions incident to such tests.

**Each Plant a Problem in Itself.**—In making a beginning, sweeping changes will be avoided, the development of the problem taking a natural course which will merely modify conditions as fast as expedient, until the whole situation shall have been harmonized with established best practice. Any business organization, particularly that of a big factory, is a delicately balanced mechanism which cannot well be rudely disturbed without unlooked-for consequences. In the preceding chapter the sweeping nature of the changes generally requisite for high efficiency have been indicated. However, it is not only inexpedient to make such a change suddenly, but practically impossible. The study of the local problem in any particular plant, the determination of what is best in the case of each of the possibly several thousand operations there performed, will require a long time and much patient study. The obvious thing is to place the undertaking, as already recommended, in charge of a competent man or a group of men selected primarily because of their experience with the new tools and their open-mindedness toward new ideas. The fixing of responsibility in one or more persons is very important. If the matter be left to the several foremen, the work will of necessity be more or less haphazard, there will be lack of uniformity in the method of attack, the experiences of one department will more than likely be lost on another, so that much work will be unnecessarily duplicated, and in general the results will be far from what might be attain-

able with expert supervision and hearty coöperation from all concerned. With all the other conditions favorable but without such coöperation, the results certainly will still fall far short; and to obtain it is in itself no small problem.

**Enlisting Coöperation.**—The conservatism and self-sufficiency of foremen is first to be met and overcome. Often this can be done through a sincere endeavor to take them "into the game" and consult with them to the fullest extent. The granting of a bonus for increased efficiency of their departments, as indicated by increased product and lowered cost, is helpful. Above all, frankness with them, and the inculcation of a spirit of enthusiastic loyalty throughout the previously existing relation between them and the management, will have smoothed the way completely. This is not a treatise on shop management, in the accepted sense; but it seems worth while to remark that the value of personal loyalty to a business, of real interest in it on the part of not only the supervisory force, but of all employees, is a most valuable asset—and unfortunately one to the conservation and development of which little attention seems generally to be paid.

**The Workman an Important Factor.**—While on the whole workmen are somewhat suspicious of efforts on the part of a management to enhance their productive capacity and the individual output, this attitude is much less in evidence in a plant where such a policy prevails as that just mentioned—that of frank and square dealing with employees, comprehending among other things a disposition to take the workmen into partnership, so to speak, and give them an opportunity to profit by increased exertion rather than to "cut the whole hog" through a piece-work wage system which fixes a maximum wage for every job and keeps for the management every advantage arising from increased efficiency and effort. In short, no greater mistake could be made, at the very beginning, than to overlook the workman who is to use the new tools. He must in the nature of the case exert greater activity and work at higher tension, and is justly entitled to a share of the profits. If no such spirit of coöperation has previously been cultivated, the inauguration of a high speed tool *régime* will be an excellent time and method for introducing also some method of wage payment which shall permit the workman to share in the profits involved in higher efficiency and increased energy. Unless some such provision be made, assuredly the attempt on the part of the management to monopolize the advantages will properly be resented, and in consequence the returns will be materially cut down below what they might be.

Furthermore, to insure permanent good feeling and continued high efficiency, it is necessary that such increment in the workman's reward shall be permanent. The policy in vogue in most piece-work shops of granting a slight increase for greater effort, only to make a reduction

later, when the newness of the thing has worn off, a reduction putting the workman on the same level of reward as before but with harder work to do, is as shortsighted as it is greedy; and it inevitably brings its own punishment—only the management generally is too obtuse to know it, even when it is a continuous occurrence. Losses are none the less large because incurred in ways intangible or unobserved.

**Tool Problem First Considered.**—In a shop where no systematic effort has been made to take large advantage of high-speed tools, it is well to make a start by inquiring into the facilities for tool making and maintenance (grinding included), and the extent to which tools will have to be bought outside. Naturally this will depend very largely upon the nature of the plant and the number of tools used. If very many, it will pay to organize a tool-making department, or to reorganize an existing one to fit the new conditions, and to secure the service of one or more expert workers with high-speed steel, according to the needs. The equipment necessary, and the methods involved in tool making, are described in the chapters dealing with that subject. In smaller establishments it will be simplest, and probably because it would be inexpedient to provide a suitable tool-making equipment and to man it with expert service it will be safest also, to buy tools made to specification. Whatever may be decided upon with reference to this point, it will be very necessary to provide adequate and dependable facilities for grinding the tools, in order to keep them in proper working condition. Neglect of this point (see chapter on Grinding) will exact the penalty in reduced efficiency and lowered returns. If for any reason hand grinding is necessary, in spite of the higher cost compared with machine grinding utilizing relatively unskilled labor, it must be carefully done by skilled hands working as closely as possible by this method to standardized shapes and angles.

**Capabilities of the Equipment.**—Also, whatever the conditions prevailing in the shop, it is very important that a careful inquiry be made into the extent and nature of the equipment, and a full report made upon each machine. This should show its kind and type; its capacity; limitations as to speed, traverse or feed, and cut; kind of work for which it is adapted and the kind for which it can be adapted; if capable of strengthening or remodeling for higher duty and to what extent and at what probable cost; the kind and probable cost of a machine of maximum capabilities to take its place; and such other data as may be found to have a bearing on the problem in hand. With these data in hand the questions as to the routing and placing of jobs under the new conditions will be much simplified, and the purchase of new machines, when this shall become necessary and expedient, can be made intelligently; without them the re-routing which may be necessary to insure the best results possible without purchasing a new machine, or the purchase of it if that

be feasible, becomes more or less guesswork. And guesswork, of all things, is studiously to be avoided if results are to count.

**Ill Advised and Unfortunate Experiences.**—A word may not be out of place here in reference to certain ill advised attempts to use high-speed tools and machines. It happens not infrequently that the management of a shop becomes acquainted with the advantages obtainable through these, and, relying upon their presentations and guarantees of steel and machine makers, purchases a supply of steel and installs the machine — only to make a signal failure in respect of realizing expectations. The unfortunate result, in such case, of course is not attributable to either steel or machine, but to their unintelligent use under conditions which would preclude the attainment of satisfactory results.

**Attacking a Specific Problem.**—Assuming that all preliminaries are arranged, so far as can be anticipated, it is in order to take up the consideration of particular jobs which may first be changed over. Evidently it will be desirable to take up immediately those cases where the work is especially trying upon the tools in use; and because of the relative simplicity of the tools and conditions, preferably turning operations. Concretely, suppose the turning of a light, high carbon shaft, requiring a long cut, be considered. The first point to determine is that of the tool to use. Only a moderately good finish being required, a standard round-nose tool will fit the case; and since the material is high carbon, the standard tool for this class of work (clearance 6 degrees, back slope 8 degrees, and side slope 14 degrees, making the lip angle 68 degrees — see chapter on Design of Tools),  $\frac{3}{4}$ -inch shank, is selected. The inclination to use tool holder stock with a view to economizing in the tool cost is best resisted, though it may possibly be found later that a composite tool is permissible. By reference to a table of standard feeds, cuts and speeds, it is seen that with this tool working on this kind of steel at the required depth of cut (for the particular operation here considered,  $\frac{3}{32}$  inch), the maximum speed under Taylor standard conditions, according as the feed is  $\frac{1}{64}$ ,  $\frac{1}{32}$ ,  $\frac{1}{16}$ , or  $\frac{3}{32}$  inch, is 110, 73.4, 49.3, or 39 feet per minute. By actual trial it is found that a feed of  $\frac{1}{32}$  inch per revolution will leave a finish sufficiently good to pass inspection; and this is therefore selected as the standard feed for the operation. The maximum speed then permissible, if the tool is to last  $1\frac{1}{2}$  hours per grinding, is 73.4 feet per minute. Summarizing, we have speed, 73.4 feet per minute, feed  $\frac{1}{32}$  inch per revolution, depth of cut  $\frac{3}{32}$  inch.

**Limitations Found and Changes Made.**—Consulting the report on the machines employed (two) on the operation, it is seen that these are incapable of running at so high a speed, mainly because they are somewhat worn and consume too much power in overcoming the friction of the machine itself when driven so rapidly. A study of the situation and consultation of the reports for other machines shows that an exchange





of the preliminary report, is so high for these machines that the vibration set up does not permit sufficient accuracy in the work and also effects a reduction in the time after which the tool must be ground; hence it becomes necessary to reduce the speed or to install new machines. The latter course being for the present inexpedient, the cutting

TOOL TEST NO. -----

PIECE ----- OPERATION -----

MATERIAL ----- CONDITION -----

TOOL ----- SIZE -----

ANNUAL REQUIREMENT ----- PIECES -----

Tool Number	No. ____	No. ____	Gain
Speed, (Feet per minute)			
Feed, (Inches per Revolution)			
Cut. (Depth)			
{ Machines } Operated			
{ Spindles }			
Cutting Time, (per Piece)			
Grinding Time, " "			
Time Allowance " "			
Actual Time for Operation,			
Daily Output			
Rate per Hundred Pieces			
Cost of Tool " "			
Cost of Power " "			
Interest & Depreciation Hundred Pieces			
Overhead Expense " "			
Cost of Scrap " "			
Total " "			

Saving on Year's Requirement \_\_\_\_\_

\_\_\_\_\_ { Machines } Available for \_\_\_\_\_ Days  
 { Spindles }

Daily Wages of Workman - Former, \_\_\_\_\_; New, \_\_\_\_\_

---

Duration of Test, ----- to -----

New Rate in Effect, -----

Date, ----- Department -----

Fig. 270. Record of data and results. Cost of power, depreciation and interest, and overhead expense are rarely of sufficient importance to require consideration. Remarks made on back of card.

speed is reduced to 58 feet per minute (provision having previously been made for such a contingency) and the result is found to be all that could be desired in respect of finish, while the tool endurance rather more than equals that anticipated. It remains then to calculate the economy effected and to rearrange the labor cost accordingly — not forgetting to take the workman into account, as already pointed out.

**Data Determined.**—From the factory records it is found that the yearly requirement is 24,000 pieces; average daily output (two lathes), 92 pieces; piecework rate, \$2.125 per hundred; average daily wage for

workman, \$1.91. Also, determined either from records or observation with stop watch, as the case may be: actual cutting time, per piece, 8 minutes; time allowance for grinding and setting tool, average, 1 minute per piece; time allowance for handling piece, cleaning machine, and other losses, 4 minutes: or a total time allowance of 5 minutes, and a total operation time of 13 minutes per piece. The actual operation

INSTRUCTION CARD.	
Piece No. _____	Department _____
Operation _____	Order No. _____
_____	
Fixtures } _____	Machines _____
Jigs } _____	
Finish _____	
Gauge _____	
Tool to use _____	
_____	
Cutting speed _____	feet per minute
Revolution of tool _____	per minute
piece	
Table feed } _____	feet per minute = _____ per { stroke
Traverse } _____	revolution
Depth of cut _____	
_____	
Change tool every _____	minutes
_____	
Lubricant or cooling agent _____	
_____	
Expected daily output _____	pieces
_____	
Directions: _____	
_____	
_____	
_____	
Date _____	Signed _____

FIG. 271. Card of instructions sent to workman with new tool when job is changed over.

time is half this, or  $6\frac{1}{2}$  minutes, since two lathes are used and two pieces are finished during each period of 13 minutes.

The data observed (or computed beforehand, if the supervisory force has sufficient skill and experience to determine this without recourse to

experiment) bring out that the actual cutting time under the new conditions is 4.5 minutes; time for changing tools, etc., 0.2 minutes; time for handling and changing piece, 2.5 minutes; or a total time of 7.2 minutes per piece. But since two lathes are used, the real time per piece becomes one half this, or 3.6 minutes; and the daily (10 hour) output is about 160 pieces, or an increase of rather more than 75 per cent. On a piecework basis, allowing the workman a substantial increase in pay (suppose we say a day rate approximating \$2.30, as against his former \$1.91) because of this greater exertion, the cost of the job can well be reduced to \$1.40 per hundred, effecting a saving \$0.725 per hundred pieces, which in a day amounts to nearly \$1.50, or an economy of more than \$220 on the year's requirement. Under a good premium or bonus wage system even this showing would be bettered.

**The Element of Tool Cost.**—This item, however, is by no means the only one through which economies are effected. There is, for example, the matter of tool cost. In most cases it might perhaps be expected that this item would be increased. As a matter of fact it rarely is so, because of the greater life of a high-speed tool and the consequent distribution of its first cost over a greatly increased output. In this particular job it turns out that there is a saving in tool cost approximating \$0.08 per hundred pieces, or not far from \$20.00 for the year's requirement. This does not include tool maintenance and grinding, in which item there would be another considerable saving, since this job was very hard upon carbon and self-hardening tools. There is also the matter of the largely increased time during which these standard machines become available for other work. Whereas before the change two lathes were required practically the whole working year (about 260 days) to get out the requirement, under the new conditions they are required for a maximum of only 150 days, leaving them available for about half the time for other work and consequently reducing capital and maintenance account by nearly one half.

**Saving in Scrap.**—Furthermore, in this job the scrap loss was previously an important factor — almost half as great, indeed, as the labor cost; and this is reduced, if not to a negligible item, at any rate to a reasonable minimum for the job. The saving through this item is shown, along with others, in the following table.

**Data Summarized.**—Quite evidently this is not a typical factory job. Nevertheless it is representative of a distinct class of operations to be found in most plants; and it has been selected as an example in order to indicate as clearly as possible the factors to be considered in changing over jobs from ordinary to high-speed tools. About the same points are involved in almost any other operation of the kind with which we are at present concerned, and the method of attack will be about the same.

TABLE X.

Item (per 100 Pieces).	Self-hardening Tool.	High-Speed Tool and Equipment.	Economy Effected.	Total, on Year's Requirement.
Piecework rate .....	\$2.125	\$1.400	\$0.725	\$174.00
Tool cost (including sharp'ng)	0.089	0.004	0.085	20.40
Insurance and interest, equip't	0.072	0.041	0.031	7.44
Scrap, net loss.....	1.050	0.160	0.890	213.60
Power <sup>1</sup> .....				
Depreciation and repairs <sup>1</sup> .....				
Totals.....	\$3.336	\$1.605	\$1.731	\$415.44

<sup>1</sup> Neglected.

**Classification of Jobs.**—So-called “try-outs” are useful in connection with the first introduction of high-speed tools, and perhaps are necessary; though the method, the time, and the order of doing the work can almost, if not quite as well, be determined in the office and prescribed for the workman without actual test, where a proper knowledge of the conditions exist. In fact it would be quite out of the question to undertake a test or to make a try-out of every one of the tens of thousands of operations in a big plant. It is enough that this be done, if at all, in a relatively few cases which are selected as typical of most those met with. All jobs are then classified according to their characteristic features, and standards established for the several classes. Evidently the analysis of a great number of very different jobs will present manifold difficulties, and some will seem to defy classification. It is imperative, however, that this be done so far as possible in order to minimize the time required for making changes and calculations. There must of course be some rational basis for such a grouping of jobs, though this may vary more or less according to local conditions and the specific nature of most of the operations. The factors here indicated are of sufficient importance to require consideration, and may be taken tentatively, at least, as a basis:

- A. { Type of machine on which job is done.  
 { Limitations and capabilities of machine available.
- B. { Material worked upon, and its particular qualities.  
 { Shape and other special characteristics of the piece operated upon, including size.
- C. { Kind of tool to be used, and its capabilities.  
 { Amount of material to be removed.  
 { Possibility of using multiple tools.  
 { Feasibility of lubricating or cooling tool or work.
- D. Finish required.

Other elements of course enter into many jobs; very likely in not a few instances they may assume importance beyond some or perhaps even all those here pointed out. This, however, is unlikely to be so, and these may safely be taken as fundamental to the determination of standards for operations except as special cases may arise. The standards once established, it should be possible to fit any given job nearly enough to a pretty clearly defined class, and to modify the conditions later as occasion or experience may indicate.

## APPENDIX A.

### ANALYSES OF HIGH-SPEED AND SPECIAL STEELS OF VARIOUS MAKES.

Steel.	Vanadium.	Molybdenum.	Tungsten.	Chromium.	Carbon.	Manganese.	Silicon.	Phosphorus	Sulphur.
1	0.32	.....	17.81	5.95	0.682	0.07	0.049	.....	.....
1a	0.29	.....	18.19	5.47	0.674	0.11	0.043	.....	.....
2	.....	.....	16.19	3.86	0.736	0.06	0.210	.....	.....
3	.....	.....	14.41	3.28	0.709	0.07	0.120	.....	.....
4	.....	.....	17.61	4.24	0.502	0.10	0.240	.....	.....
5	.....	.....	14.23	3.44	0.739	0.06	0.165	.....	.....
6	.....	.....	25.45	2.23	0.838	0.29	0.034	.....	.....
7	.....	.....	14.91	5.71	0.790	0.06	0.060	.....	.....
8	.....	0.48	17.79	2.84	0.650	0.12	0.087	0.013	0.012
9	.....	.....	19.64	2.85	0.760	0.30	0.090	.....	.....
10	.....	.....	18.99	2.61	0.670	0.20	0.265	0.014	0.009
11	.....	.....	23.28	2.80	0.800	0.11	0.165	0.015	0.009
12	.....	2.03	18.93	3.52	0.580	0.19	0.125	0.029	0.016
13	.....	4.21	13.44	3.04	0.760	0.09	0.052	.....	.....
14	.....	.....	24.64	7.02	0.600	0.03	0.205	.....	.....
15	.....	.....	19.97	3.88	1.280	0.14	0.220	.....	.....
16	.....	.....	19.16	5.61	0.790	.....	.....	.....	.....
17	.....	7.60	9.25	6.11	0.320	0.13	0.081	.....	.....
18	0.28	.....	16.00	3.50	0.700	.....	.....	.....	.....
19	.....	.....	16.00	3.50	0.700	.....	.....	.....	.....
20	.....	.....	14.71	2.90	0.700	0.12	0.196	0.017	0.010
21	.....	.....	15.31	2.88	0.540	0.12	0.133	0.018	0.009
22	.....	0.75	14.91	2.80	0.450	0.10	0.090	0.018	0.008
23	.....	.....	14.62	2.81	0.600	0.18	0.320	0.017	0.009
24	.....	6.25	.....	4.30	0.900	0.12	0.481	0.016	0.008
25	.....	.....	10.68	3.67	1.160	0.10	1.340	0.024	0.008
26	.....	.....	14.91	2.95	0.705	0.01	.....	0.013	0.008
26a	.....	.....	14.29	2.85	0.791	.....	.....	.....	.....
26b	.....	.....	13.40	2.93	0.800	0.06	.....	0.020	0.008
27	.....	.....	17.27	2.70	0.250	.....	0.179	0.035	.....
28	.....	.....	16.48	4.10	0.370	0.18	0.090	0.014	0.008
29	.....	.....	18.66	2.69	0.640	0.24	0.393	0.012	0.014
30	.....	5.19	14.83	2.90	0.750	0.08	.....	0.020	0.010
31	.....	.....	17.60	5.11	0.490	.....	.....	0.010	0.007
32	.....	.....	19.00	6.00	0.650	0.10	0.200	0.018	0.019
33	.....	0.78	16.75	4.58	0.560	0.17	0.110	0.020	0.007
34	.....	9.61	.....	.....	0.650	0.20	0.038	0.016	0.006
35	.....	.....	13.00	2.88	0.620	.....	.....	0.020	0.010
36	.....	.....	17.54	2.72	0.440	0.12	0.100	0.017	0.010
37	.....	.....	19.09	.....	0.550	0.27	0.070	0.016	0.010
38	.....	.....	17.81	2.48	0.550	0.11	0.090	.....	.....
39	.....	.....	19.03	.....	0.660	.....	0.036	0.015	.....
40	.....	.....	14.27	3.55	0.790	0.08	0.150	0.028	0.008
41	.....	.....	18.40	2.89	0.660	0.12	0.135	0.010	0.008
42	.....	.....	15.29	1.85	0.320	0.15	0.340	0.019	0.006
43	.....	.....	16.22	4.73	0.400	0.18	0.120	0.025	0.008
44	.....	4.38	10.08	3.00	0.540	0.16	.....	.....	.....
45	.....	0.34	13.76	4.49	0.500	0.07	0.210	0.015	0.005
46	.....	.....	4.78	0.69	0.940	0.27	0.110	0.010	0.010
47	.....	.....	0.46	0.00	1.030	0.30	0.118	0.025	0.009
48	.....	.....	7.56	3.34	1.190	0.46	0.200	0.024	0.025
49	.....	.....	2.25	0.28	1.250	0.85	0.210	.....	.....

## MEMORANDA.

Analyses numbered from 1 to 25 inclusive are those given by Taylor. 1 and 1a are the same steel, the one referred to by him as the best of all those used in the Taylor-White experiments.

44 is the average of the analyses of 12 different melts of the same steel, or rather of steel marketed under the same name.

45 is high-speed, but not of the highest grade.

46, 47 and 48 are steels recently put upon the market as "semi-high-speed" or "intermediate" steels.

49 is sold as a steel especially adapted to finishing cuts. It is not at all in the high-speed class.

## APPENDIX B.

### FRED W. TAYLOR ON THE VARIOUS METHODS OF HARDENING HIGH SPEED STEEL TOOLS.<sup>1</sup>

**Special Treatments Unnecessary.**—For some years past it has been rather amusing to us to hear the special directions given by the various manufacturers of steel suitable in chemical composition for making the high-speed tools. Very frequently a tool steel maker implies, or directly states, that the chemical composition of his particular high speed tool steel requires “special treatment.” The fact is, however, that our recent experiments demonstrate beyond question the fact that no other method which has come to our attention produces a tool superior in red hardness (*i.e.*, high speed cutting ability), or equal in uniformity to the method described. This applies to all makes of high speed tool steels which are capable of making first-class tools, whatever their chemical composition.

**Various Methods Tried.**—It is the writer’s belief that during our long series of experiments at the Bethlehem Steel Company, in our search for uniform tools and for the method of imparting the highest degree of red hardness to tools, we tried substantially every method which has since come to our attention.

For instance, in giving the tools the high heat we heated them in a blacksmith’s coke fire, a blacksmith’s soft-coal fire, in muffles over a blacksmith’s fire, and in gas-heated muffles. We also constructed various furnaces for this purpose. We heated tools by means of an electric current, with noses under water, and out of water, and by immersion in molten cast iron. Moreover, by every one of these methods we were able to produce a first-class tool, provided only the tool was heated close to the melting point.

**Cooling Experiments.**—In cooling from the high heat we experimented with a large variety of methods. After being heated close to the melting point, tools were immediately buried in lime, in powdered charcoal, and in a mixture of lime and powdered charcoal; thus they

<sup>1</sup> The extensive investigations, and prodigious amount of time and labor devoted to them in the development of high-speed steels and their treatment, give to the following extract from Mr. Taylor’s address or report a special significance. The paragraphs are 1001 to 1006 inclusive, at pages 200 and 201 of the address “The Art of Cutting Metals,” already mentioned.



were cooled extremely slowly, hours being required for them to get below a red heat. And we wish clearly to state the fact that tools cooled even as slowly as this, while they were in many cases quite soft and could be filed readily, nevertheless maintained the property of "red hardness" in as high a degree as the very best tools, and were capable of cutting the medium and softer steels at as high cutting speeds as the best tools which were cooled more rapidly and which were much harder in the ordinary sense.

Tools were also cooled from the high heat in a muffle or slow cooling furnace with a similar result. On the other hand, we made excellent high-speed tools by plunging them directly into cold water from the high heat, and allowing them to become as cold as the water before removing them. Between these two extremes of slow and fast cooling; cooling in lime, charcoal, or a muffle, on the one hand, and in cold water on the other; other cooling experiments covering a wide range were conducted. We tried cooling them partly in water and then slowly for the rest of the time; partly in oil, and then slowly for the rest of the time; partly by a heavy blast of air from an ordinary blower and the rest of the time slowly; partly under a blast of compressed air and then slowly. We also reversed these operations by cooling first slowly and then fast, as described. We also cooled them entirely in an air blast and entirely in oil, and then partly first in oil, afterward in water, and then first in water and afterward in oil.

**Good Tools by all Methods.**—By every one of these methods we were able to make a good high-speed tool; *i.e.*, a tool having a large degree of red hardness, and capable of cutting at very high cutting speeds. But by none of these processes were we able to obtain tools as uniform and regular as those produced by our lead bath and air cooling.

## APPENDIX C.

### REFERENCE TABLE FOR DETERMINING CUTTING SPEEDS.

Feet per Minute.	5	10	15	20	25	30	35	40	45	50
Diam. in Inches.	REVOLUTIONS PER MINUTE.									
1/2	38.2	76.4	114.6	152.9	191.1	229.3	267.5	305.7	344.0	382.2
3/8	30.6	61.2	91.8	122.5	153.1	183.7	214.3	244.9	275.5	306.1
1/2	25.4	50.8	76.3	101.7	127.1	152.5	178.0	203.4	228.8	254.2
3/4	21.8	43.6	65.5	87.3	109.1	130.9	152.7	174.5	196.3	218.9
1	19.1	38.2	57.3	76.4	95.5	114.6	133.8	152.9	172.0	191.1
1 1/8	17.0	34.0	51.0	68.0	85.0	102.0	119.0	136.0	153.0	170.0
1 1/4	15.3	30.6	45.8	61.2	76.3	91.8	106.9	122.5	137.4	153.1
1 1/2	13.9	27.8	41.7	55.6	69.5	83.3	97.2	111.1	125.0	138.9
1 3/4	12.7	25.4	38.2	50.8	63.7	76.3	89.2	101.7	114.6	127.1
1 7/8	11.8	23.5	35.0	47.0	58.9	70.5	82.2	93.9	105.7	117.4
1 3/2	10.9	21.8	32.7	43.6	54.5	65.5	76.4	87.3	98.2	109.1
1 5/8	10.2	20.4	30.6	40.7	50.9	61.1	71.3	81.5	91.9	101.9
2	9.6	19.1	28.7	38.2	47.8	57.3	66.9	76.4	86.5	95.5
2 1/4	8.5	17.0	25.4	34.0	42.4	51.0	59.4	68.0	76.2	85.0
2 1/2	7.6	15.3	22.9	30.6	38.2	45.8	53.5	61.2	68.8	76.3
2 3/4	6.9	13.9	20.8	27.8	34.7	41.7	48.6	55.6	62.5	69.5
3	6.4	12.7	19.1	25.5	31.8	38.2	44.6	51.0	57.3	63.7
3 1/4	5.5	10.9	16.4	21.8	27.3	32.7	38.2	43.6	49.1	54.5
4	4.8	9.6	14.3	19.1	23.9	28.7	33.4	38.2	43.0	47.8
4 1/4	4.2	8.5	12.7	16.9	21.2	25.4	29.6	34.0	38.1	42.4
5	3.8	7.6	11.5	15.3	19.1	22.9	26.7	30.6	34.4	38.2
5 1/4	3.5	6.9	10.4	13.9	17.4	20.8	24.3	27.8	31.3	34.7
6	3.2	6.4	9.6	12.7	15.9	19.1	22.3	25.5	28.7	31.8
7	2.7	5.5	8.1	10.9	13.6	16.4	19.1	21.8	24.6	27.3
8	2.4	4.8	7.2	9.6	11.9	14.3	16.7	19.1	21.1	23.9
9	2.1	4.2	6.4	8.5	10.6	12.7	14.9	17.0	19.1	21.2
10	1.9	3.8	5.7	7.6	9.6	11.5	13.4	15.3	17.2	19.1
11	1.7	3.5	5.2	6.9	8.7	10.4	12.2	13.9	15.6	17.4
12	1.6	3.2	4.8	6.4	8.0	9.6	11.1	12.7	14.3	15.9
13	1.5	2.9	4.4	5.9	7.3	8.8	10.3	11.8	13.2	14.7
14	1.4	2.7	4.1	5.5	6.8	8.1	9.6	10.9	12.3	13.6
15	1.3	2.5	3.8	5.1	6.4	7.6	8.9	10.2	11.5	12.7
16	1.2	2.4	3.6	4.8	6.0	7.2	8.4	9.6	10.7	11.9
17	1.1	2.2	3.4	4.6	5.6	6.7	7.9	9.0	10.1	11.2
18	1.1	2.1	3.2	4.2	5.3	6.4	7.4	8.5	9.6	10.6
19	1.0	2.0	3.0	4.0	5.0	6.0	7.0	8.0	9.1	10.1
20	1.0	1.9	2.9	3.8	4.8	5.7	6.7	7.6	8.6	9.6
21	.9	1.8	2.7	3.6	4.5	5.5	6.4	7.3	8.1	9.1
22	.9	1.7	2.6	3.5	4.3	5.2	6.1	6.9	7.8	8.7
23	.8	1.7	2.5	3.3	4.1	5.0	5.8	6.6	7.5	8.3
24	.8	1.6	2.4	3.2	4.0	4.8	5.6	6.4	7.2	8.0
25	.8	1.5	2.3	3.1	3.8	4.6	5.3	6.1	6.9	7.6
26	.7	1.5	2.2	2.9	3.7	4.4	5.1	5.9	6.6	7.3
27	.7	1.4	2.1	2.8	3.5	4.2	5.0	5.7	6.4	7.1
28	.7	1.4	2.0	2.7	3.4	4.1	4.8	5.5	6.1	6.8
29	.7	1.3	2.0	2.6	3.3	4.0	4.6	5.3	5.9	6.6
30	.6	1.3	1.9	2.5	3.2	3.8	4.5	5.1	5.7	6.4

The revolutions per minute for any greater speed may be obtained by multiplication and addition. Suppose it is desired to find the r.p.m. of a milling cutter having a diameter of  $4\frac{1}{2}$  inches and expected to run at a peripheral speed of 85 feet per minute. The required number may be found by following the line opposite the given diameter,  $4\frac{1}{2}$ , to the column under 40, where is found the number 34.0; and also to the column under 45, where is found the number 38.1. Adding these numbers we have the required r.p.m. for a speed of  $40 + 45$ , or 85 feet per minute, which is 72.1. If the r.p.m. for a surface speed of, say 120 feet, is required, it may be found by multiplying the number in the column under 20 by 6, which in the case of a  $2\frac{3}{4}$  inch cutter would be  $27.8 \times 6$  or 166.8.

Conversely, the surface speed required for a given diameter and r.p.m. can be determined, though for this the use of the following formula is simpler:  $S = D \times R \times .2618$ , in which  $S$  is the surface speed in feet per minute,  $D$  the diameter, and  $R$  the revolutions per minute. We also have:

$$D = \frac{R \times .2618}{S}.$$

APPENDIX D.

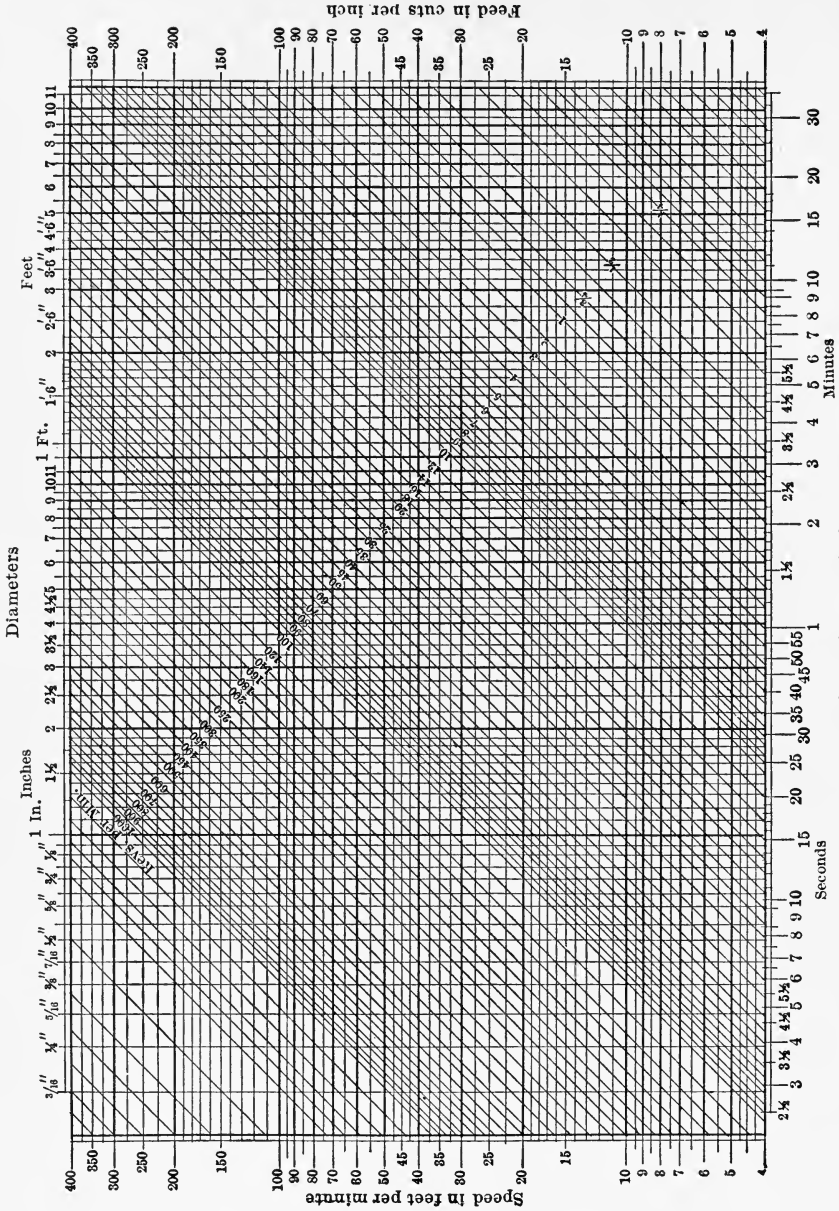

FIG. 272. Diagram for determining time of turning operations.

As shown in the enlarged section, follow the vertical line representing the given diameter to its intersection with the horizontal line corresponding to the required surface speed; follow the diagonal nearest this point

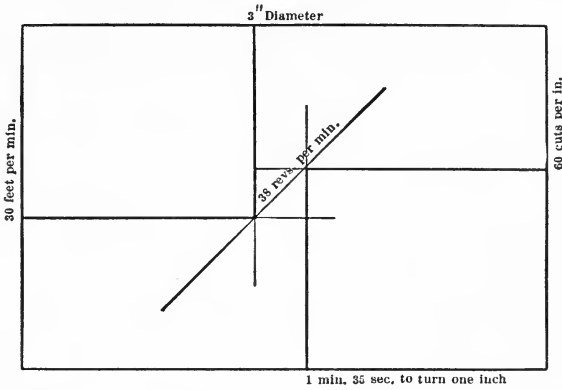

FIG. 273. Enlarged section of Fig. 272, showing method of determining time of operation.

up or down, until it meets the horizontal line corresponding to the desired feed as read from the left of the table. A vertical line dropped from this point to the bottom line will there show the time in minutes it will take to turn one inch under the given conditions. Diagram by A. Thompson, re-published by courtesy of *Machinery*, New York.

**APPENDIX E.**  
**SUMMARY OF METAL REMOVED AND COST OF REMOVAL.**

Material.	Machine.	Cost of Removing 1 lb. of Metal.			Cost of Running 1 Minute.		Total Cost, for 1 hr.	Average per Day of 10 hrs.		Average Cost per Day.		
		Tool Steel.	Labor and Machine.	Total.	Tool Steel.	Labor and Machine.		Consump- tion of Tool Steel.	Wt. of Metal Re- moved.	Tool Steel.	Labor and Machine.	Total.
Tires.....	90" Lathe	.00271	.00812	.01083	.00700	.0217	\$1.7220	7.27	1608	\$4.36	\$13.00	\$17.36
Axles.....	36" Lathe	.00370	.00355	.00725	.00830	.0080	.9780	8.35	1350	5.01	4.80	9.81
Cast Iron.....	48" Planer	.00550	.00320	.00870	.00230	.0080	.6180	2.34	252	1.46	4.75	6.15
Cast Iron.....	36" Lathe	.00210	.00440	.00650	.00380	.0080	.7080	3.86	1092	2.29	4.80	7.09
Steel.....	96" Brg. Mill	.00250	.03900	.04150	.00140	.0212	1.3560	1.37	324	.84	12.75	13.59
Cast Steel.....	60" Planer	.00420	.02900	.03320	.00159	.0111	.7614	1.60	228	.96	6.65	7.61

Result of actual experience in a large shop under exceptionally good conditions — in fact conditions established with the prime motive of using high-speed tools with maximum effect.

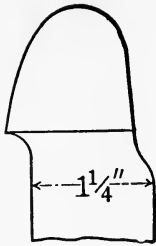

## APPENDIX F.

### PRACTICAL TABLE OF CUTTING SPEEDS: STANDARD $1\frac{1}{4}$ " TOOL.

Depth of Cut in Inches.	Feed in Inches.	Cutting Speed in Feet per Minute for a Tool which is to Last 1 Hour and 30 Minutes before Re-grinding.					
		Soft Cast Iron.	Medium Cast Iron.	Hard Cast Iron.	Soft Steel.	Medium Steel.	Hard Steel.
$\frac{3}{32}$	$\frac{1}{64}$	239	119.6	69.8	518	259	118
	$\frac{1}{32}$	191	95.3	55.6	366	183	83.2
	$\frac{1}{16}$	142	70.8	41.3	257	129	58.4
	$\frac{3}{32}$	118	59.1	34.4	209	105	47.5
	$\frac{1}{8}$	103	51.7	30.2	.....	.....	.....
	$\frac{3}{16}$	85.0	42.5	24.8	.....	.....	.....
$\frac{1}{8}$	$\frac{1}{64}$	216	108	63.1	450	225	102
	$\frac{1}{32}$	172	86.2	50.3	317	158	72.0
	$\frac{1}{16}$	128	64.0	37.3	223	112	50.7
	$\frac{3}{32}$	107	53.4	31.2	182	90.8	41.4
	$\frac{1}{8}$	93.4	46.7	27.3	157	78.5	35.7
	$\frac{3}{16}$	76.8	38.4	22.4	.....	.....	.....
$\frac{3}{16}$	$\frac{1}{64}$	187	93.5	54.6	370	185	84.1
	$\frac{1}{32}$	149	74.6	43.6	260	130	59.1
	$\frac{1}{16}$	111	55.5	32.7	183	91.7	41.6
	$\frac{3}{32}$	92.5	46.3	27.0	149	74.6	33.8
	$\frac{1}{8}$	73.1	36.5	21.3	129	64.5	29.3
	$\frac{3}{16}$	66.4	33.2	19.4	105	52.6	23.8
$\frac{1}{4}$	$\frac{1}{64}$	168	84.1	49.1	322	161	73.2
	$\frac{1}{32}$	134	67.2	39.2	227	113	51.6
	$\frac{1}{16}$	99.8	49.9	29.1	159	79.7	36.1
	$\frac{3}{32}$	83.2	41.6	24.3	130	65.0	29.5
	$\frac{1}{8}$	72.6	36.3	21.2	112	56.1	25.5
	$\frac{3}{16}$	59.7	29.8	17.4	91.4	45.7	20.8
$\frac{3}{8}$	$\frac{1}{64}$	144	71.8	41.9	264	132	60.0
	$\frac{1}{32}$	115	57.3	33.4	186	93.1	42.3
	$\frac{1}{16}$	85.1	42.6	24.8	131	65.5	29.8
	$\frac{3}{32}$	70.9	35.5	20.7	107	53.4	24.1
	$\frac{1}{8}$	62.0	31.0	18.1	92.2	46.1	20.8
	$\frac{3}{16}$	51.0	25.5	14.9	.....	.....	.....
$\frac{1}{2}$	$\frac{1}{64}$	131	55.6	38.3	230	115	52.3
	$\frac{1}{32}$	105	52.3	30.5	162	80.9	36.8
	$\frac{1}{16}$	77.6	38.8	22.7	114	56.9	25.9
	$\frac{3}{32}$	64.7	32.4	18.9	92.6	46.3	21.0
	$\frac{1}{8}$	56.6	28.3	16.5	.....	.....	.....
	$\frac{3}{16}$	46.5	23.3	13.6	.....	.....	.....
$\frac{3}{4}$	$\frac{1}{64}$	112	56.0	32.7	.....	.....	.....
	$\frac{1}{32}$	89.2	44.6	26.0	.....	.....	.....
	$\frac{1}{16}$	66.2	33.1	19.3	.....	.....	.....
	$\frac{3}{32}$	55.2	27.6	16.1	.....	.....	.....
	$\frac{1}{8}$	48.3	24.2	14.1	.....	.....	.....
	$\frac{3}{16}$	39.7	19.8	11.6	.....	.....	.....

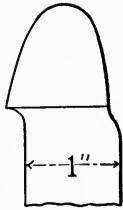

PRACTICAL TABLE OF  
CUTTING SPEEDS: STANDARD 1" TOOL.

Depth of Cut in Inches.	Feed in Inches.	Cutting Speed in Feet per Minute for a Tool which is to Last 1 Hour and 30 Minutes before Re-grinding.					
		Soft Cast. Iron.	Medium Cast Iron.	Hard Cast Iron.	Soft Steel.	Medium Steel.	Hard Steel.
$\frac{3}{32}$	$\frac{1}{64}$	226	113	66.0	490	245	111
	$\frac{1}{32}$	177	88.4	51.6	339	169	77.0
	$\frac{1}{16}$	130	64.8	37.8	235	117	53.4
	$\frac{3}{32}$	107	53.5	31.2	189	94.5	43.0
	$\frac{1}{8}$	92.8	46.4	27.1	.....	.....	.....
	$\frac{3}{16}$	75.7	37.8	22.1	.....	.....	.....
$\frac{1}{8}$	$\frac{1}{64}$	205	102	59.8	427	214	97.0
	$\frac{1}{32}$	160	85.1	46.8	296	148	67.2
	$\frac{1}{16}$	118	58.8	34.3	205	102	46.6
	$\frac{3}{32}$	97.0	48.5	23.3	165	83.0	37.5
	$\frac{1}{8}$	84.2	42.1	24.6	142	71.0	32.3
	$\frac{3}{16}$	68.6	34.3	20.0	.....	.....	.....
$\frac{3}{16}$	$\frac{1}{64}$	181	90.6	52.9	358	179	81.3
	$\frac{1}{32}$	142	70.8	41.3	247	124	56.1
	$\frac{1}{16}$	104	51.9	30.3	171	85.5	38.8
	$\frac{3}{32}$	85.8	42.9	25.0	138	69.0	31.3
	$\frac{1}{8}$	74.3	37.2	21.7	118	59.0	26.8
	$\frac{3}{16}$	60.6	30.3	17.7	95.0	47.5	21.6
$\frac{1}{4}$	$\frac{1}{64}$	165	82.3	48.1	315	157	71.6
	$\frac{1}{32}$	129	64.4	37.5	218	109	49.5
	$\frac{1}{16}$	94.3	47.1	27.5	150	75.0	34.1
	$\frac{3}{32}$	77.8	38.9	22.7	121	60.5	27.5
	$\frac{1}{8}$	67.5	33.7	19.7	104	52.0	23.6
	$\frac{3}{16}$	55.0	27.5	16.1	.....	.....	.....
$\frac{3}{8}$	$\frac{1}{64}$	143	71.5	41.8	263	132	59.8
	$\frac{1}{32}$	112	56.0	32.6	182	91.0	41.4
	$\frac{1}{16}$	81.9	41.0	23.9	126	62.8	28.5
	$\frac{3}{32}$	67.6	33.8	19.7	101	50.6	23.0
	$\frac{1}{8}$	58.6	29.3	17.1	.....	.....	.....
	$\frac{3}{16}$	57.5	28.7	16.8	.....	.....	.....
$\frac{1}{2}$	$\frac{1}{64}$	132	66.2	38.6	232	116	52.7
	$\frac{1}{32}$	104	51.6	30.2	161	80.5	36.6
	$\frac{1}{16}$	75.8	37.9	22.1	111	55.7	25.3
	$\frac{3}{32}$	62.6	31.3	18.3	.....	.....	.....
	$\frac{1}{8}$	54.2	27.1	15.8	.....	.....	.....
	$\frac{3}{16}$	44.2	22.1	12.9	.....	.....	.....





PRACTICAL TABLE OF  
CUTTING SPEEDS: STANDARD  $\frac{3}{8}$ " TOOL.

Depth of Cut in Inches.	Feed in Inches.	Cutting Speed in Feet per Minute for a Tool which is to Last 1 Hour and 30 Minutes before Re-grinding.					
		Soft Cast Iron.	Medium Cast Iron.	Hard Cast Iron.	Soft Steel.	Medium Steel.	Hard Steel.
$\frac{3}{32}$	$\frac{1}{64}$	220	110	64.2	476	238	108
	$\frac{1}{32}$	169	84.6	49.4	325	162	73.8
	$\frac{1}{16}$	122	61.2	35.7	222	111	50.4
	$\frac{3}{32}$	99.8	49.9	29.1	177	88.4	40.2
	$\frac{1}{8}$	86.4	43.2	25.2	.....	.....	.....
	$\frac{3}{16}$	70.1	35.1	20.5	.....	.....	.....
$\frac{1}{8}$	$\frac{1}{64}$	202	101	58.9	420	210	95.5
	$\frac{1}{32}$	156	77.8	45.4	286	143	65.0
	$\frac{1}{16}$	112	56.2	32.8	195	97.6	44.4
	$\frac{3}{32}$	91.8	45.9	26.8	156	77.9	35.4
	$\frac{1}{8}$	79.3	39.7	23.2	133	66.4	30.2
	$\frac{3}{16}$	64.3	32.2	18.8	.....	.....	.....
$\frac{3}{16}$	$\frac{1}{64}$	178	89.0	52.0	352	176	80.0
	$\frac{1}{32}$	137	68.6	40.1	240	120	54.5
	$\frac{1}{16}$	99.4	49.7	29.0	164	82	37.3
	$\frac{3}{32}$	81.0	40.5	23.7	131	65.5	29.8
	$\frac{1}{8}$	70.1	35.0	20.5	112	56.0	25.5
	$\frac{3}{16}$	56.8	28.4	16.6	.....	.....	.....
$\frac{1}{4}$	$\frac{1}{64}$	163	81.5	47.7	312	156	70.9
	$\frac{1}{32}$	126	62.9	36.7	213	107	48.4
	$\frac{1}{16}$	90.8	45.4	26.5	145	72.6	33.0
	$\frac{3}{32}$	74.1	37.0	21.6	116	58.1	26.4
	$\frac{1}{8}$	64.1	32.0	18.7	.....	.....	.....
	$\frac{3}{16}$	52.0	26.0	15.2	.....	.....	.....
$\frac{3}{8}$	$\frac{1}{64}$	144	71.8	41.9	264	132	60.0
	$\frac{1}{32}$	111	55.4	32.3	180	90.2	41.0
	$\frac{1}{16}$	80.0	40.0	23.4	122	61.1	27.8
	$\frac{3}{32}$	65.3	32.6	19.1	.....	.....	.....
	$\frac{1}{8}$	56.4	28.2	16.5	.....	.....	.....
	$\frac{3}{16}$	45.8	22.9	13.4	.....	.....	.....
$\frac{1}{2}$	$\frac{1}{64}$	135	67.5	39.4	237	118	53.8
	$\frac{1}{32}$	104	52.1	30.4	162	80.8	36.7
	$\frac{1}{16}$	75.2	37.6	22.0	.....	.....	.....
	$\frac{3}{32}$	61.4	30.7	17.9	.....	.....	.....
	$\frac{1}{8}$	43.1	21.6	12.6	.....	.....	.....



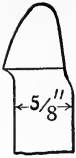

PRACTICAL TABLE OF  
CUTTING SPEEDS: STANDARD  $\frac{5}{8}$ " TOOL.

Depth of Cut in Inches.	Feed in Inches.	Cutting Speed in Feet per Minute for a Tool which is to Last 1 Hour and 30 Minutes before Re-grinding.					
		Soft Cast Iron.	Medium Cast Iron.	Hard Cast Iron.	Soft Steel.	Medium Steel.	Hard Steel.
$\frac{1}{16}$	$\frac{1}{64}$	.....	.....	.....	548	274	125
	$\frac{1}{32}$	.....	.....	.....	358	179	81.6
	$\frac{1}{16}$	.....	.....	.....	235	117	53.3
$\frac{3}{32}$	$\frac{1}{64}$	216	108	63.0	467	234	106
	$\frac{1}{32}$	160	80.0	46.6	306	153	69.5
	$\frac{1}{16}$	110	55.0	32.2	200	100	45.5
	$\frac{3}{32}$	88.4	44.2	25.8	156	78.0	35.5
	$\frac{1}{8}$	75.4	37.7	22.0	.....	.....	.....
$\frac{1}{8}$	$\frac{1}{64}$	200	100	58.6	417	209	94.8
	$\frac{1}{32}$	148	74.0	43.3	273	136	62.0
	$\frac{1}{16}$	104	51.8	30.2	179	89.3	40.6
	$\frac{3}{32}$	82.6	41.3	24.1	140	69.8	31.7
	$\frac{1}{8}$	69.6	34.8	20.3	.....	.....	.....
$\frac{3}{16}$	$\frac{1}{64}$	183	91.6	68.0	362	181	82.2
	$\frac{1}{32}$	135	67.5	39.4	236	118	53.8
	$\frac{1}{16}$	94.0	47.0	27.4	155	77.4	35.2
	$\frac{3}{32}$	75.4	37.7	22.0	.....	.....	.....
	$\frac{1}{8}$	64.3	32.2	18.8	.....	.....	.....
$\frac{1}{4}$	$\frac{1}{64}$	171	85.7	50.1	328	164	74.5
	$\frac{1}{32}$	126	63.2	36.9	215	107	48.8
	$\frac{1}{16}$	87.8	43.9	25.6	.....	.....	.....
	$\frac{3}{32}$	70.4	35.2	20.6	.....	.....	.....
$\frac{3}{8}$	$\frac{1}{64}$	156	77.8	45.4	286	143	65.0
	$\frac{1}{32}$	116	57.8	33.8	.....	.....	.....
	$\frac{1}{16}$	79.7	39.9	23.3	.....	.....	.....



**PRACTICAL TABLE OF  
CUTTING SPEEDS: STANDARD  $\frac{1}{2}$ " TOOL.**

Depth of Cut in Inches.	Feed in Inches.	Cutting Speed in Feet per Minute for a Tool which is to Last 1 Hour and 30 Minutes before Re-grinding.					
		Soft Cast Iron.	Medium Cast Iron.	Hard Cast Iron.	Soft Steel.	Medium Steel.	Hard Steel.
$\frac{1}{16}$	$\frac{1}{64}$	.....	.....	.....	510	255	116
	$\frac{1}{32}$	.....	.....	.....	322	161	73.2
	$\frac{1}{16}$	.....	.....	.....	203	102	46.2
$\frac{3}{32}$	$\frac{1}{64}$	206	103	60.0	445	223	101
	$\frac{1}{32}$	147	73.3	42.8	281	141	63.9
	$\frac{1}{16}$	97.5	48.8	28.5	177	88.7	40.2
	$\frac{3}{32}$	76.0	38.0	22.2	135	67.4	30.7
	$\frac{1}{8}$	64.1	32.1	18.7	.....	.....	.....
$\frac{1}{8}$	$\frac{1}{64}$	194	97.0	56.7	404	202	91.8
	$\frac{1}{32}$	138	69.3	40.4	255	128	57.9
	$\frac{1}{16}$	93.1	46.5	27.2	161	81	36.6
	$\frac{3}{32}$	72.1	36.1	21.3	.....	.....	.....
	$\frac{1}{8}$	41.8	20.9	12.2	.....	.....	.....
$\frac{3}{16}$	$\frac{1}{64}$	182	91.0	53.0	359	179	81.6
	$\frac{1}{32}$	128	64.0	37.7	226	113	51.4
	$\frac{1}{16}$	86.1	43.1	25.1	.....	.....	.....
	$\frac{3}{32}$	67.4	33.7	19.6	.....	.....	.....
$\frac{1}{4}$	$\frac{1}{64}$	173	86.3	50.4	330	165	25.0
	$\frac{1}{32}$	122	61.0	35.7	.....	.....	.....
	$\frac{1}{16}$	81.9	41.0	23.9	.....	.....	.....

# INDEX

- Abrasion of cutting edge, 224  
tools subjected to, 211
- Absorbent glasses, in pyrometry, 169
- Absorption of power — see Power absorption
- Abutments, in composite tools, 268
- Accelerated production — see Maximum production, and Production
- Acceleration speed planers, 292
- Accuracy of pyrometers, 162, 169, 171
- Acetylene blow-pipe welding of tools, 184
- Air chucks — see Chucks
- Air hardening steels, discovery of, 13, 14  
see also High-speed steels
- Air quenching, 84, 97, 98
- Allowance for grinding, 76, 150  
machining, 190, 227  
shrinkage, etc., 180
- Alloy bath method of tempering, 123
- Alloy steels (see also Steels, High-speed steels, etc.),  
22  
cutting speeds on, 245
- Alpha iron, 33, 34, 38
- Aluminum, cutting speeds on, 245, 250  
in steel, 44  
lubrication in cutting, 233, 269  
milling of, 250, 269  
rake or front slope for cutters working  
on, 269  
table traverse in, 250
- Analysis of steel — see Steels, composition of
- Ancient steel making — see Steel, Manufacture of;  
Damascus; Crucible process, etc.
- Angles, cutting, in non-clearance tools, 257  
influence on cutting speeds and efficiency,  
235  
lip, influence on cutting speed, 235  
standard for tools, 255
- Annealed steel, constituents of, 25, 27  
stock, advantages in use of, 61, 65, 66, 129
- Annealing after forging, 76  
desirable in certain cases, 185  
discoloration of tool surface during, 132  
furnace, 129  
in remaking old tools, 185  
manganese steel, effect on, 39  
methods of, 61, 129, 133  
rapid, 130  
temperature range in, 131, 132  
time required, 130, 131, 132  
tungsten steels, 40
- Anthracite fuel in heating furnaces, 67
- "Anvil" principle in machine design, 279
- Apparatus — see Equipment
- Appendices, 330
- Appliances, need for adequate, 67, 122  
see also Equipment
- Arbor hole in rotary cutters, 269
- Armor plate, cutting speeds on, 250  
milling, 196, 250
- Austenite, 29, 35, 38  
fixing of, 39
- Austenitic condition, fixing, 35  
effect of heat treatment on, 42  
steels and red-hardness, 47
- Autogenous welding of high-speed tools, 183
- Automatic machine tools — see Machine tools
- Auxiliary drives, 288  
motors, use of, 285
- Back knives, composite (welded), 184  
rest, attachment of, 285  
slope in lathe tools, 257
- Band saws, high-speed steel, 201
- Barium chloride, 113  
process of hardening, 105 *et seq.*  
process of hardening, carbon steel  
tools, 117
- Bar stock, cutting, 185
- Barth slide rule, 236
- Bath hardening of tools, 107  
oil for quenching, 99  
operation of, in barium chloride process, 113  
quenching, 99  
tempering of tools, method of, 123 *et seq.*
- Bearings, proportions of, in high-speed machine  
tools, 283
- Belt drive, 286  
for auxiliary movements of machine  
tools, 288
- Bessemer converter, 10, 11  
steel, 9, 11  
method of manufacture, 10-11
- Beta iron, 33, 34, 38
- Billets, high-speed steel, 59
- "Black body" radiation, 171
- Blisters, formation of, on surface of tools, 119
- Blistering, prevention of, in heating tools, 92, 108
- Blades, inserted — see Composite tools; Design of  
tools; and under various tools
- Bolometer, 158
- Boring operations, speeds in (see also Drilling), 247
- Brakes on machine tools, 289
- Brass cutting operations, 211, 233  
speeds and feeds in, 245,  
249, 250  
treatment of tools for,  
96, 128

- Brazing, in manufacture of composite tools (see also Composite tools; Compound tools, etc.), 182, 183
- Breakage of tools, 140, 194, 199, 201, 298  
materials, minimizing of, 305
- Bristol pyrometer, 158, 162, 163, 164
- Brittleness ruinous in tools, 121
- Broaching operations, 205
- Bronze, high-speed tools for cutting, 211
- Brown platinum pyrometer, 158-159
- "Bubbles," formation of, on tool surfaces, 119
- "Burnt" skin, removal of, from tools, 149
- Calibration of pyrometers, 87, 162, 164, 170
- Capacity of machine tools, relation to powering, 289
- Carbon in steel, 23, 24, 32, 33  
steel, composition of, 23  
microscopic structure of, 26  
tools, hardening by barium chloride process, 117
- Carriage (lathe), attachment of, 282, 285
- Cast iron, cutting speeds on, 190, 244, 248, 249, 250  
efficiency of high-speed tools in cutting, 190, 223
- Castings, allowance for machining, 228  
and heavy cutting, 190  
chilled, growing use of, 192
- Cast steel, 8
- Catalan forge, 3
- "Cementation" steels, 7
- Cementite, 27, 28, 38
- Chain drive for machine tools, 289
- Chatter, conditions making for, 153, 212, 226, 230, 235, 252, 253, 254, 255, 267, 272  
effect on cutting speed, 230, 242, 325  
tool endurance, 212, 259
- Checks or cracks in tool surfaces, 136, 148, 152  
detecting, 185
- Chilled iron, machining, 192, 193, 241, 245
- Chipping castings, high-speed tools for, 207
- Chip, action of tool in cutting, 215, 224  
cooling of, 232  
development of heat in removing, 5  
distortion of, 218  
high-speed not unique, 234  
in drilling operations, 248  
production, variables affecting, 235, 242  
shape of, and tool efficiency, 254  
shearing of into sections, 220
- Chips, disposal of, 233, 292, 294  
nature and production of, 5, 6, 212, 235, 248, 254, 258
- Chisels, high-speed, 207  
tempering, 128
- Chlorine fumes, in barium chloride bath operation, 113, 119
- Chrome steel, cutting speeds on, 245  
for tool holders and tool bodies, 261, 263, 272
- Chromium, cost of, 62  
influence in steel, 25, 39, 40, 44
- Chucks and other holding devices, design of, 308
- Cleaning tool surfaces, in barium chloride process, 116
- Clearance angle, 256
- Clearance angle, influence on cutting speed, 235, 242  
modification of, in certain cases, 226  
in drills, 142, 273  
internal cutting tools, 247  
milling cutters, 142, 195, 268  
reamers, 271, 272  
of chips in aluminum cutting, 269  
tools without (non-clearance tools), 257
- Classification of jobs, 306
- Clutches, modification of, in reciprocating machines, 298
- Coke furnace (see also Furnace), 66
- Colors, discrimination of, 93, 122, 124, 155  
relation to temperature, 65, 93, 122, 124, 155, 156, 166
- "Cold end" in temperature maintenance, 163
- Compensator, use of, in pyrometry, 164
- Composite tools (see also under separate tools), 183, 200, 209, 210, 262  
cost of, 195, 265, 317  
design of, 183  
dies, 203, 206  
lathe centers, 284  
method of securing cutters, 183, 265, 266, 268  
reamers, 200, 271  
renewal of cutters or blades, 267  
rotary, 263  
saws, 202  
shears, 203  
wood working, 209, 210  
See also Compound tools; Tool holders; Welding; etc.
- Composition of steels — see Steels, composition of
- Constituents of steel, 25-38
- Conditions of maximum effect, 212 *et seq.*  
efficiency, variation in, 239
- Conservatism in use of high-speed steel, 64, 275, 303
- Consistency in temperature gages, 171
- Contour of cutting edges — see Design of tools; Chatter; etc.
- Cooling, in annealing, 130, 132  
changes caused in heated steel by, 30, 32  
comparative effect, in heated steel, of rapid and slow, 31-32  
cutting tools while at work, 232, 238  
effect on cutting speed, 241, 249  
in grinding tools, 148, 151  
in hardening — see Hardening; Quenching; etc.
- Contour of cutting edge — see Design of tools; Chatter, Efficiency; etc.
- Cooperation in organization for maximum production, 321
- Coring and reaming compared with drilling, 190, 197
- Cost of high-speed steel, 61-63  
constituents, 62  
tools, comparative, 195  
metal cutting and of metal removed, 338  
tool maintenance, 192  
tools, basis of, 190  
comparative, 327

- Cost of tools, composite, 195, 265, 317  
 lowered, 306  
 reduction, 237, 300
- Cracks, formation of, 68, 69, 97  
 detection of, 185
- Critical points, 29-36  
 ascertaining, 177  
 influence of manganese, nickel,  
 chromium, etc., on, 39  
 lag in cooling, 30  
 range of, 41
- Cross rails, form of, 280  
 section of tools, 252
- Crucible process, 55  
 antiquity of, 3, 55  
 development of, 8  
 later methods, 8, 55  
 manufacture of wootz, 3  
 revived by Huntsman, 8
- steel, 3, 8  
 among the ancients, 3-8  
 préminence of, 8  
 See also Steel
- Cup wheels for tool grinding, 142
- Cut, depth of, 242  
 allowable in malleable castings, 227  
 effect on chatter, 226  
 influence on efficiency and speed of  
 tool, 235  
 in castings with chilled surfaces, 304  
 standardized, 238  
 duration of, influence on cutting speed,  
 235  
 meter, Warner, 240
- Cutter heads for wood working machines, 209
- Cutters, inserted — see Composite tools; Tool hold-  
 ers; Compound tools; Design of tools;  
 etc.  
 milling — see Milling cutters; Composite  
 tools; etc.
- Cutting action, tearing away of chip, 215, 221  
 angles, in internal cutting tools, 247  
 influence on cutting speeds, 235, 242  
 cost of and of metal removed, 338  
 drills, influence on feed, 248  
 in non-clearance tools, 257  
 standard, 255  
 See also Angles
- edge, abrasion of  
 amount of curve, 255  
 conduction of heat from, 262-263  
 contour of, 242, 253  
 not under heavy pressure, 221  
 shape and angle of, influence on speed  
 and efficiency, 235
- edges, brazed or welded — see Composite  
 tools; Compound tools; etc.  
 relation of number to life of the tool,  
 269
- effect of high speed in, 6  
 off dies, hot, 206  
 stock from bars, 65
- operations, nature of, 215 *et seq.*  
 pressure on tool in (see also  
 Vibration; Chatter, Pressure  
 oscillations; etc.), 19
- Cutting operations, softening of tool in, 224  
 support of tool in, 228  
 speed, determining, 240  
 effect on cost of production, 237  
 tool, 6  
 factors affecting, 235, 236, 240, 241  
 high, when undesirable, 238  
 in chilled iron cutting, 241, 245  
 maximum limits, carbon steel tools, 6  
 high-speed tools, 18  
 relation to chattering, 227-228  
 variables affecting, 235, 236, 240-  
 241
- speeds and feeds, generalizations as to, 236  
 table of, for drilling and  
 like operations, 249  
 case of short duration cuts, 306  
 commercially practicable, 238, 292  
 drills, etc., 197, 240, 248, 249  
 in boring jobs, 247  
 finishing jobs, 208  
 milling nickel-chrome steel, 196  
 milling operations, 250  
 planer and shaper work, 194,  
 250  
 planer and shaper work, com-  
 mercially practicable, 292  
 roughing cuts, 245  
 wood working operations, 209  
 maximum, 241  
 maximum with carbon steel tools,  
 302  
 on cast iron, 191, 244  
 malleable castings, 245  
 steel, 245  
 phenomenal, 244  
 reamers, 248-249  
 relation of, in certain operations,  
 247  
 table for determining, 334  
 Taylor standard, 238, 339  
 threading tools, 249-250  
 with soft tools, 333
- time, diagram for ascertaining, 336
- tools, action of, 215  
 factors in efficiency of, 226  
 see also Tools, design of; Harden-  
 ing; Tempering; Efficiency; An-  
 nealing; Forging; Temperature;  
 etc.  
 transformation of energy in, 5
- Cylindrical furnace — see Furnace
- Damascus steel, 3, 4, 5, 8  
 Dannemora iron, use in high-speed steel, 62
- Data, securing of, as basis for standard tempering  
 temperatures, 127  
 in temperature regulating, 175  
 manufacture of high-speed  
 tools, 178  
 establishment of conditions  
 for maximum production,  
 235, 323
- Defects of early high-speed steels, 186
- Dead melting, in crucible process, 9, 58
- Depth of cut — see Cut

- Design, end sought in, 212  
of furnaces — see Furnace  
machine tools, 212, 275 *et seq.*  
adjustments, 212, 285  
auxiliary motors, use of,  
285, 287  
bearings, 283  
brakes, 289  
distribution of material,  
279  
lathes, 279 *et seq.*  
milling machines, 286  
new requirements, 317  
planing machines, 286  
pulling and feeding power  
a factor in speeds and  
feeds, 242  
relation of powering to  
capacity,  
rigidity, 212  
solidity, 280  
speed changes, 287  
summary, 294  
torsional strains, 286  
variable-speed motors for  
driving, 287  
weight essential, 280  
See also Machine tools
- tool rests, 285  
tools, 252, 319  
composite (inserted cutter), 265  
considerations affecting, 261  
continuity of structure desirable,  
182  
contour of cutting edge, 242  
dies, 274  
composite, 206  
drills, 141, 273  
factors affecting efficiency, 226  
milling cutter blades, 266-267  
milling cutters, 229, 263, 266-267  
clearance in, 195  
front slope in, 267,  
269  
helical, 266  
inserted cutter,  
195  
interlocking sec-  
tional, 270  
nicked cutting  
edges, 270  
overhang in  
blades, 268  
pitch in, 195, 268,  
269  
welded cutter  
blades, 184  
miscellaneous, 274  
overhang of inserted cutter blades,  
268  
rotary, 263  
threading taps and dies, 201  
Taylor on, 261  
wood working, 274
- Diameter of work, influence on cutting speed and  
efficiency, 235
- Dies, composite, 184, 203  
design of — see Design, above  
deterioration of, 204  
drawing, 206  
efficiency of, 203  
efficiency of blanking, 204  
embossing, 206  
forming, 206  
hardening of, 114, 118  
temperature for, 96-97  
heading, 206  
high-speed, 203  
hot cutting-off, 206  
forming and pressing, 206  
pneumatic tool, 207  
quenching or cooling, 100  
"sinking" of, 206  
snap, 207  
threading, breakage of, 201  
cutting the threads, 181  
design of, 201  
hardening of, 117-118  
temperature, 96  
prevention of rough surfaces and  
cutting edges, 181  
tempering, 127-128  
tongs for handling, 119
- Disc grinders, disadvantages of, in certain cases,  
146  
Discoloration in annealing, 132  
Discoveries, modern method of making, 20  
Dog, use of, in turning operations, 308  
Drawing temper — see Tempering  
Dressing grinding wheels, 138  
Drilling, compared with coring and reaming, 190,  
197  
punching, 197  
cooling or lubricating the drill, 233  
feeds and speeds in, 197, 244, 248  
machine for using high-speed drills with  
maximum efficiency, 277  
weak, 298  
remodeled, 295  
removal of chips, 233
- Drills, breakage of, 199, 248  
clearance in, 141, 273  
finish of the flutes, 273  
flat, use and efficiency of, 199  
grooved, 199  
multiple lip, efficiency of, 199  
peripheral speed of, 248  
splitting of, 273  
twist, design of, 273  
twisted, 273  
in plate drilling, 199  
welded shank, 184  
See also Design; Economy; Efficiency; Feeds  
and speeds; Grinding; Hardening; Tem-  
pering; etc.
- Drive, belt, 286  
electric, 286, 289  
for operating heavy tail stocks, 285  
in remodeled machines, 296  
of reciprocating machines, remodeling of,  
298  
Drives, auxiliary, 285, 288



- Eccentricity in rotary cutters, relation to chatter, 230
- Economies, effecting, 327  
 elements affecting, 237  
 table of, in a specific case, 328
- Edge tools—see Tools; Hardening; Grinding; Tempering; etc.
- Efficiency, comparative, of rotary and reciprocating cuts, 194  
 contrasts, 302  
 maximum, conditions of, 310  
 measure of, 232  
 relative, of grinders, 135  
 tool, blanking dies, 203-204  
   brass, bronze, German silver working, etc., 211  
   drills, finish of flutes and, 273  
     flat, 199  
     multiple-lipped, 199  
     twist, 197-201  
     twisted, 186, 274, 300  
 factors affecting, 188, 197, 235, 252  
 forming dies, 206  
 high-speed tools in general, 20  
 in cast iron cutting, 190, 223  
 influence of shape in, 254  
 machine tool equipment a factor in, 276  
 milling cutters, 194-195  
 multiple-lipped drills, 199  
 planer and shaper work, 194  
 punches, 204  
 reamers, 199  
 relation to prime and maintenance cost, 192  
 rock working, 211  
 rotary compared with reciprocating, 194  
 successive grindings and, 76  
 taps and dies, 201  
 variables affecting, 188, 197, 235, 252  
 wood working, 210
- Egypt, early use of steel tools in, 1
- Electric drive—see Drive
- Electrical annealing, 133  
 furnace, see Furnace  
 hardening, methods of, 102  
 method of steel manufacture, 12  
 process of making high-speed steel, 55  
 resistance pyrometer, 158, 164  
 tempering, 126  
 welding of compound or composite tools, 183
- Elements in composition of steel, 23-25, 46-51, 330  
 influence of, see Hardening
- Embossing dies, 206
- Energy, transformation of, in metal cutting operations, 1
- Endurance limits of machine operator, 304, 310  
 tools, 6  
 of cutting tools, factors affecting, 212, 226  
 machine tools, 307
- Engineering, place of high-speed steel in, 186, 300
- Engineering, place of mushet steels in, 14  
 works, production in, 279
- Equipment, barium chloride hardening process, 109  
 forging, 66, 73, 87  
 gas manufacturing, 81  
 grinding, 141  
 hardening, air quenching, 97  
   furnaces, 78-86  
   heat regulating (see also Pyrometry), 86  
   oil quenching, 99  
   supplemental, 87  
 machine tool, policy of scrapping, 295, 303  
   remodeling old, 295-299  
   tool efficiency and, 276, 322  
 manufacture of high-speed tools and adequate, 67, 78, 82  
 quenching, air, 97  
   oil, 99
- Excess metal, grinding from tools, 149
- Experiences, misleading, 64, 323
- Experimentation—see Tests
- Facility, securing, in machine tools, 212
- Factory organization and maximum production, 217, 320
- Feed devices, positive, on drilling machines, 249  
 drive, power absorbed in, 253  
 effect on chattering, 226  
 factors effecting, 242  
 or traverse, pressure in case of non-clearance tools, 258  
 stresses, 289  
 table for determining, 334  
 wood working operations, 209
- Feeds and speeds, drills, 197, 244, 248, 249  
 gain in case of rotary tools, 194  
 milling operations, 250, 268  
 reamers and like tools, 249  
 See also Speeds
- Ferrite, 27-30, 38
- Fery pyrometer—see Pyrometer
- "Fiddle" principle in machine design, 279
- File cutting chisels, hardening temperature for, 97
- File test, 180
- Files, high-speed, 201
- Finish grinding in toolmaking, 149  
 in wood working operations, 209  
 influence on efficiency of drills, 273
- Finishing chilled castings, 193  
 cuts, effect of using poorly ground tools on, 230  
 efficiency of high-speed tools, in, 208  
 speeds in, 250  
 hardening temperature for, 96  
 in manufacture of high speed steel bars, 59  
 tools, grinding of, 137
- Fire—see Forging; Hardening; etc.
- Fire end pyrometer, 159  
 ends (pyrometer), care and protection of, 164-165

- Fire ends (pyrometer), deterioration of, 162, 165  
 Fish oil, for quenching bath, 100  
 Fixtures, use of, in accelerated production, 212  
 Fixing the state of steel, 33  
 Flat drills — see Drills  
 Flaws and cracks — see Cracks  
 Flushing, in grinding, 136, 148, 151  
 Forge, catalan, 3  
   gas, 66, 67  
   shop, place of high-speed tools in, 206  
 Forging, primitive, 1  
   or machining tools, expediency of, 77  
   the tools, 64 *et seq.*  
     expedients in, 73  
     fire for heating, 66, 68  
     gages for use in, 73  
     hammering, cautions as to, 70  
     heating for, 68  
     rough or close, expediency of, 73  
     successive steps in, 71  
     temperature required, 69  
     tungsten steels, difficulty of, 39, 71  
 Forming cutters, hardening temperature, 96  
   dies, 206  
   knives for wood working, 209  
 Formulas in metal cutting operations, 236  
   theoretical, for high speed steel composition, 45  
 Foster ring turret lathe, 278  
 Frames of machine tools, spring in, 298  
 Front slope in milling cutters, 267-269  
 Fuel for heating furnaces — see Furnaces  
 Fumes, disposal of, 107  
   from barium chloride bath, 113  
   from lead bath, 107  
 Furnace, annealing, 129  
   barium chloride treatment, 109  
   coke fired, 67, 78  
   crucible, 86  
   cylindrical, 86  
   design of, 78, 82, 109, 130  
   electrical, 111  
     operation of, 113  
   equipment for toolmaking plant, 84  
   fuel to use, 67, 78, 80  
   gas fired, 80  
     convenience and economy of, 67  
     operation of, 111  
     venting of, 111  
   hardening, 78  
   melting, in high speed steel manufacture, 55  
   oil fired, 78  
   muffle, use in steel making, 7  
   oil fired, 78  
   open hearth, 9  
   temperature fluctuations in, 107  
   tempering, 82, 122, 124  
 Gages, forging limits, 73  
   function in accelerated production, 315  
 Gaging temperature — see Temperature  
 Gamma iron, 33, 34, 38  
 Gas, as a furnace fuel, 80  
 Gas, cost of, 81  
   forge — see Furnace  
   furnace — see Furnace  
   kind to use in gas fired furnaces, 82  
   plant for manufacture of, 81  
 Gear cutters, 196  
 Gears, in machine tools, 289  
   strengthening of, in remodeling machines, 297  
   stripping of, in reciprocating machines, 298  
 German silver, high-speed tools for working, 211  
 Glazing of grinding wheels, 135  
 Gladwin, Mr. Henry, improves method of air hardening, 14  
 Gledhill, Mr. J. M., on cooling tools, 102  
 Graphite, free, in steel, 27, 29  
 Grinding, nature of the operation, 136  
   of tools, 134 *et seq.*  
     allowance for, in size of tool, 76, 150  
     amount of material removed, 152  
     automatic or hand, 140  
     checking of surfaces in, 148  
     cup wheel, advantages of in, 142, 146  
     design of machines for, 138  
     direction the wheel should run, 150  
     disc wheels, disadvantages of, in certain cases, 146  
     drills, 137, 148  
     dry or wet, 148  
     edge tools, 137  
     equipment for, 141  
     face or land (back), 152, 267  
     finishing tools, 137  
     frequency of, 152, 230, 303  
       and lip slope, 257  
       relation to cutting speeds, 235, 241  
     hot tools, 76, 149  
     importance of proper, 134  
     improper, and effect on finish cuts, 230  
     inaccurate, and chatter of tool, 230  
     increase of efficiency with successive grindings, 76, 149  
     intervals between (see also *frequency*, above), 303  
     jigs or fixtures for, 142, 145  
     off excess metal, 76, 149  
     organization for, 322  
     positive feed in, 146  
     prior to hardening, 76, 92, 148  
     proper, a factor in efficiency, 237  
     rotary tools, 230  
     ruin of tools in, 135, 136  
     stone to use, 134  
     V-shaped periphery, advantages of, in certain cases, 147  
     wheel to use, 134, 148  
   wheels, dressing of, 138  
   glazing of, 135  
   kind of, to use, 134, 148

- Grinding wheels, "loading" of, 135  
 running speed of, 138  
 truing of, 138
- "Guttering" of tools, 222
- Hack saws, high-speed, 201
- Hadfield steel, use of, in chilled roll finishing, 193
- Hammer, power, advantages of, in forging, 70
- Hammering high speed steel bars, 61
- Hammering, in forging, 70
- Hammers, high-speed, 207
- Hand tools, high-speed, 200
- Handling tools in the barium chloride process, 118  
 heating, 96  
     special tongs for, 97
- Hardening, barium chloride process, 105 *et seq.*  
 bath for heating, use of, 107  
 carbon steel tools by barium chloride  
 or other bath process, 117  
 dies, 118  
 difficulty of, in case of certain tools, 265  
 drills, method when using oven fur-  
 nace, 96  
     quenching or cooling of, 100  
     temperature for, 96  
     vertical furnace for, 83  
 edge tools, temperatures, 96  
 effect of tongs on, 94  
 electrical, 102  
 elements, 62  
     cost of, 62  
     influence of the several, in  
     steel, 32, 39-45  
 essentials of the method, 101  
     Taylor-White method,  
     101  
 Fred W. Taylor on, 332  
 heating — see Heating, below; also  
     Temperature regulation, etc.  
 influence of carbon on, 32  
     chromium on, 39, 44  
     manganese on, 39-44  
     molybdenum, aluminum,  
     and tantalum on, 44  
     nickel on, 39  
     sulphur and phosphorus  
     on, 45  
     titanium, uranium, and  
     vanadium on, 43  
     tungsten on, 40-45  
 lead bath method, 107  
 martensite produced in, 35  
 method of heating, 93-96  
     ordinary, 13  
 mushet steels, 13, 14  
 plant, arrangement of, 87  
     equipment for, 84  
 pre-heating the tools in, 92  
 superheating, effect of, 16  
 temperatures — see Temperature  
 theory of, 25-35, 38  
 water cooling, 51, 53, 97  
 See also Heating; Quenching; Temper-  
 ature; etc.
- Hardness, extreme, not essential in high-speed  
 tools, 121, 180
- Hardness, of material, relation to cutting speed,  
 257  
     tool, effect on cutting speed, 240  
 red-, — see Red-hardness  
 test, 180
- Hartness, Mr. James, on non-clearance tools, 257  
 type of tools — see Non-clearance tools
- Head, lathe, design of, 281
- Heading dies, 206
- Heat, development of, in metal cutting, 6, 182  
 dissipation of, at the cutting edge, 232, 257,  
 262-264  
 regulation of — see Temperature regula-  
 tion  
 treatment of high-speed steel, theory of, 42  
     manganese steel, 39  
     steel, effect of, 29
- Heating, difficulties of, in ordinary furnace, 107  
 duration and extent of, in annealing, 131  
     barium chlo-  
     ride process,  
     114  
     forging, 68  
     hardening, 91  
     tempering, 125  
 effect of rapid and of slow, compared, 31  
     uneven, in forging, 68  
 for annealing, 130-133  
     forging, 68  
     hardening, 91, 113-116  
     tempering, 122-126  
 gradual, necessary in forging, 66, 68  
 handling of tools while, 96, 118  
 in lead bath, 107  
 method of, in hardening, 93, 96  
 of tool during grinding, 136  
 slender tools,  
 uniformity in barium chloride process,  
 107-108
- Heavy cutting, high-speed tools and, 187  
 on castings, 190  
 or close forging, 188, 190  
 pre-eminence of high-speed tools in,  
 188  
 when desirable, 188
- Helical milling cutters, 266
- High-heat treatment, 15, 20  
 and red-hardness, 47  
 see also Barium chloride  
 process; Hardening; Heat-  
 ing; Taylor-White pro-  
 cess; etc.
- High-speed cutting, power absorbed in, 194  
 razors, 19, 208  
 steel, adaptability of, 211  
     analysis or composition of, 25,  
     46, 47, 48, 330  
     brands or makes, 17  
     selection of, 319  
 characteristic properties of, 47  
 composition of — see *analysis*,  
 above  
 constituents of, 62  
 cost of, 62-63  
 defects of early, 17, 186  
 development of, 17, 20

- High-speed steel, especial field for, 187, 303  
 heat-treatment of (see also Heat-  
 ing; High-heat treatment; etc.),  
 42  
 influence of the ingredients (see  
 also Hardening), 32-45  
 limitations of, 211  
 manufacture of, 55-63  
 marvels of, 18  
 "new," "superior," "improved,"  
 etc., 51-53  
 place of, in engineering, 186  
 range of utility, 186 *et seq.*  
 reason for high cost, 61  
 recent developments in, 51-53  
 relation to mushet steel, 46  
 stunted use of, 64, 275  
 theoretical formulas for, 45  
 wood-working tools, 18, 209-210  
 tools — see Tools  
 when undesirable, 238
- Holborn-Kurlbaum pyrometer, 158, 167
- Holding tools in machines, 285
- Hood for forge fire, 66, 91, 130
- Hoskins pyrometer, 158, 162, 163
- Hot-forming and pressing dies, 206
- Hot grinding of tools, 149
- Howe, Professor, theory of steel hardening, 38
- Huntsman, revives crucible process, 8
- Ice bobbin, use of, in pyrometry, 164
- Identification of tools, 76
- "Improved" high-speed steels, 51-53
- Industrial revolutions, manner of accomplishment,  
 19, 300
- Indication of temperatures, distant (see also Tem-  
 perature), 160, 169, 173, 175
- Ingot molds, in manufacture of high-speed steel, 59
- Ingot, topping of, 62
- Ingredients of high-speed steel, influence of the  
 several, 32-45
- Inserted-cutter tools — see Composite tools; Tool  
 holders; etc.
- Inspection, careful, a factor in effecting econom-  
 ies, 237
- Interlocking milling cutters, 270
- "Intermediate" steels, nature and composition of,  
 50-53  
 need and utility of, 49
- Internal cutting, speeds in, 247
- Iron, alpha, beta, gamma, and magnetic, 33, 34, 38
- Jigs and fixtures, use of, 212, 278  
 design of, in accelerated production, 308  
 for tool grinding, 142, 145  
 use of, a factor in accelerated production, 237  
 See also Chucks
- Jobs, changing over to use of high-speed tools, 323  
 classification or standardization of, 306, 328
- Kerosene for quenching, in hardening, 100
- "Killing" or "dead melting" in crucible steel manu-  
 facture, 58
- Knives, high-speed steel, 209  
 wood-working, 18, 109-210
- Labor, an important factor in tool efficiency, 252
- Lag, in annealing, 172  
 conversion of steel constituents, 30  
 cooling as compared with heating critical  
 range, 30  
 pyrometers, 164, 171
- Land grinding, on rotary tools, 142, 152, 267
- Lathe beds, form of, 279, 281
- Lathe beds, design of, 284  
 continuous head and bed, 283  
 design — see Machine tool design  
 heads or stocks, 281  
 Lo-Swing type, 281  
 primitive, 2  
 ring-turret, 278  
 stocks, adjustability of, 281  
 tail, 284  
 tools — see Tools
- Lead bath, difficulties in use of, 107  
 uses of, 94
- Lead, in twist drills, 73
- Le Chatelier pyrometer — see Pyrometer
- Length or duration of cut, effect on cutting speed,  
 241
- "Letting down" martensite, 37  
 or tempering, 121
- Life of tool — see Tool; Grinding; Endurance; etc.
- Limitations of high-speed steel, 211  
 tools, 187, 207
- Limits gages, in forging, 73  
 of pyrometer ranges, 158
- Line shafting, power absorbed by, 287, 289
- Lip angle, influence on cutting speed, 235  
 surface, pitting, guttering, or wearing of, in  
 metal cutting, 223-224  
 pressure upon, in cutting, 217 *et seq.*
- "Loading" of grinder wheels, 135
- Lo-Swing lathe, 281
- Low-heat treatment and tempering, 122  
 in the Taylor-White method of  
 hardening, 102  
 superfluous?, 102
- Lubricant or cooling agent, effect of, on cutting  
 speeds, 235, 241, 249
- Lubrication in cutting aluminum, 269  
 remodeled machines, 296  
 of cutting tools, 232  
 machine tools, 283
- Machine operator — see Workman  
 tool equipment a factor in tool efficiency,  
 276  
 tools, adjustments in, 285  
 automatic, and high-speed thread-  
 ing tools, 201  
 place of, 304-305, 310  
 tool lubrication, 232  
 brakes on, 289  
 design — see Design  
 endurance of, 307  
 new types, 276  
 requirements, 317 *et seq.*  
 pulling and feeding power, influence  
 on possible speeds, 242  
 reciprocating, limitations of, 290  
 relation of powering to capacity, 289

- Machine tools, remodeling of, 295-299, 307, 317, 324  
 rigidity in, 212  
 scrapping of, single purpose, 278  
 superseding of, 308, 317  
 speed changes in, 287  
 tool efficiency and adequate equipment, 188  
 torsional strains in, 286  
 use of, with high-speed tools, 298  
 types, inadequacy of old, 19
- Machinery, influence on development of steels, 5
- Machining, allowance for, in manufacturing, 227  
 tools from stock compared with forging, 129  
 unannealed high-speed steel, 61  
 compared with forging and finish machining, in rapid production, 66, 77
- Magnetic chucks or jigs, use of, in rapid production, 308  
 property of steel, effect of heat on, 29
- Maintenance cost of machines, 307
- Malleable castings, allowance for machining of, 227  
 broaching of, 205  
 iron, cutting speeds and feeds on, 245, 249-250
- Manganese and red-hardness, 44  
 effect on hardening, 39  
 influence and importance of, in high-speed steel, 13, 23, 44  
 steel, effect of annealing, 39  
 heat treatment of, 39  
 unsuitable for cutting tools, 39  
 use in chilled roll turning, 193
- Manganese-bessemer steel, 13
- Manufacture of high-speed steel, 55 *et seq.*  
 tools — see High-speed tools  
 steel, later methods, 7-12  
 primitive methods, 1-5
- Marble working, 211
- Marking of tools, 76
- Martensite, 33  
 in high-speed steel, 42  
 nature of, 38  
 produced in the hardening process, 35
- Material, character of, influence on cutting speeds, 250  
 handling and storage of, 312  
 of, a factor in rapid production, 237  
 in process, routing of, 322  
 reduction of scrap in, 306  
 non-uniformity of, 303  
 refractory, cutting of, 303, 323  
 transportation and storage of, 312, 318
- Maximum effect, conditions of, 212 *et seq.*  
 production, conditions of, 239, 304, 310  
 factory organization and, 317  
 intelligent supervision and, 317, 318  
 wage system and, 321  
 See also Production
- Melting high-speed steel, methods of, 56, 58  
 point of high-speed steel, 96
- Mésure and Nouel pyrometer — see Pyrometer
- Metal cutting, ancient methods, 2  
 cost of, 338  
 development of, 5, 14  
 limitations of tools, 14  
 nature and theory of, 215-228  
 pressure oscillations in — chatter, 226  
 problems involved, 226  
 nature of the variables in, 240  
 tearing action in chip formation, 221  
 quality of, effect on cutting speed, 240  
 working, ancient, 2
- Method, scientific, and industry, 178
- Methods — see under the various processes
- Milling and planing compared, 194  
 cutters, allowance for shrinkage, 181  
 clearance required, 195  
 in aluminum cutting, 269  
 composite (see also Composite tools), 263  
 design of — see Design  
 efficiency of (see also Efficiency), 194-196, 208  
 front slope in, 267  
 grinding of, 137, 141, 142, 148  
 hardening temperatures, 96  
 heating for hardening, 93  
 helical, 266  
 inserted teeth (see also Composite tools), 195  
 interlocking, 270  
 nicked edges, 270  
 number of teeth, 195, 268, 269  
 peripheral speeds, 250  
 "riding" of, 244  
 shape of cutting teeth, 266  
 tempering, 127  
 feeds in, 247, 250, 268  
 in finishing operations, 208  
 refractory materials, 196  
 speed or feed increase?, 194  
 speeds in, 247, 250  
 traverse in, 244
- Motor drive — see Drive
- Motors for auxiliary drives, 285, 288  
 variable speed, in machine driving, 287
- Molybdenum, cost of, 62  
 influence in high-speed steel, 44
- Morse thermo gage, 158, 167
- Muffle furnace, use of, 7
- Muffles, use in oil-fired furnaces, 78
- Multiple tools, use of, in rapid reduction, 198, 200, 246
- Mushet, improves the crucible process, 8  
 develops self-hardening or mushet steel, 13, 24  
 steel, character and composition of, 23, 40, 46  
 discovery of, 13  
 effect of high-heat treatment on, 15  
 introduction of, 8, 14  
 place in engineering  
 relation to high-speed steel, 46  
 tungsten and chromium in, 41

- "New" high-speed steels, 51-53  
 hardening of — see Hardening  
 quenching in water, 53, 97  
 tempering, 121
- Nicholson experiments, 213, 220, 221, 253
- Nickel, influence in high-speed steel, 44  
 effect on hardening, 39  
 steel, 39  
 cutting speeds on, 245, 250  
 use for tool holders, etc., 263
- Nickel-chrome steel, milling of, 196  
 thermo-couple, 161
- Nicking of milling cutter teeth, 270  
 or stamping tools, 76, 185
- Nomenclature of steels, 22
- Non-clearance cutting tools, 216, 242, 257, 259, 286, 287
- Non-cutting operations, high-speed tools for, 203
- Non-metal working operations, high-speed tools in, 209
- Non-uniformity of material and use of high-speed tools, 303
- Nozzles, in wet grinding, 148
- Odors, suppression of, in oil quenching bath, 100
- Oil as a cooling agent in grinding, 148  
 fired furnace — see Furnace  
 quenching in (see also Quenching), 79-100  
 tempering furnace, 124  
 operation of, 125
- Open hearth steel, manufacture of, 9
- Operator, machine — see Workman
- Optical pyrometry (see also Pyrometer), 158, 165, 166, 169
- Ores, primitive methods of extracting, 1
- Organization of shop and maximum production, 310  
 tool room — see Tool room; and Tool supply  
 problem of, 300
- Overhang of tools, 228, 229  
 relation to number of grindings, 267
- Overload, provision for, in powering of machine tools, 297
- Oxidation, air quenching and, 99, 114  
 cause of, 95  
 in the heating furnace, 68, 80  
 of the lead bath, 108  
 prevention of, in annealing, 130-132  
 barium chloride process, 105, 108, 114  
 hardening, 94, 105-106
- Pack-hardening, 94
- Paper cutting knives, high-speed, 209
- Paraffine oil as a lubricant in cutting operations, 233, 269  
 aluminum cutting, 269
- Pearlite, 27  
 conversion of, 29  
 nature of, 38
- Performances of carbon steel tools, 6
- Performances of high-speed tools, 18, 52  
 "new" high-speed steels, 52  
 see also Efficiency
- Peripheral speeds, drills, 248  
 milling cutters, 250  
 table and method for determining, 334
- Personal equation in temperature determination, 93, 124, 156, 171
- Phosphorus, effect of, in steel, 23  
 influence in high-speed steel, 45
- Photometric pyrometer, 158, 166
- "Pickling," in the manufacture of high-speed steel, 62
- Pitch, in cutters working on aluminum, 269  
 milling cutters, 268
- "Pitting," of surface of tools in hardening, 119  
 (wearing) of cutting lip of tool, 223, 224
- Planer tool, compound, 183  
 tools, 194  
 breakage of, 194  
 (wood), knives, 209
- Planers, accelerated speed, 292  
 see also Reciprocating tools
- Planing compared with rotary cutting, 194  
 cutting speed in, 194, 250  
 efficiencies in, 194  
 machine design (see also Design of machine tools), 286
- Platinum-rhodium thermo-couple, 161
- Pneumatic tools, dies for, 207  
 hardening temperatures, 97
- "Poker" pyrometer, 159
- Power absorbed by line shafting, 287, 289  
 machine tools, 287  
 old types of machines, 303  
 in feed drive, 253  
 rapid cutting, 194, 286  
 available, a factor in cutting speeds, 244  
 required, a factor in the use of high-speed tools, 307  
 transmission of, 289
- Powering, ample, a requisite in high-speed machines, 278  
 in remodeled machines, 296  
 of machine tools, 286  
 provision for overloads, 297  
 relation to capacity, 289
- Pre-grinding, wheel for use in, 148
- Pre-heating furnace, 79, 92  
 in the barium chloride process, 115, 116  
 tool hardening, 92, 115, 116
- Premium system of wage payment and the use of high-speed tools, 310
- Press dies, 206  
 working operations, 206
- Pressure, air and gas in gas-furnace operation, 82, 111  
 feed, in case of non-clearance tools, 258  
 on lip of tool, influence on cutting speed and efficiency, 236  
 tool in cutting operations, 19  
 non-clearance cutting tools, 258

- Pressure on tool, influence of, 238  
 oscillations in metal cutting, 214, 219,  
 220, 226  
 on cutting tools, 254
- Primitive tools and methods of making them, 1
- Prismatic pyrometer, 158, 166
- Problem of organization, 300
- Problems in the use of high-speed tools — see High-speed tools
- unintelligent attacking of, 64
- Production, accelerated, methods of securing (see also Maximum production), 323  
 maximum — see Maximum production  
 psychology and physiology of, intensified, 304
- "Pulling" the crucible, 56
- Punches, high-speed, 203  
 design of, 274  
 efficiency of, 204  
 forging or machining of, 77  
 hardening temperatures, 96  
 tempering of, 128
- Punching operations, 204  
 replaced by drilling, 197
- Pyramids, tools used in construction of, 1
- Pyrometer, adaptation to purpose, 157  
 attention to, in heating operations, 93  
 Bristol thermo-couple, 158, 162-164  
 Brown platinum, 158-159  
 electrical resistance, 158, 164  
 expansion, 158, 159  
 Fery absorption, 158, 166  
 radiation, 86, 158, 169-171  
 Holborn-Kurlbaum, 158, 167  
 Hoskins thermo-couple, 158, 162, 163  
 in hardening, 86  
 lag in, 164, 171  
 Le Chatelier electrical resistance, 165  
 optical, 158, 166  
 thermo-couple, 158-161  
 manipulation of, 165  
 Mésure and Nouel, 158, 166  
 optical, 158, 165 *et seq.*  
 photometric, 158, 166  
 power of discrimination, 162-171  
 prismatic, 158, 166  
 radiation, 158, 169, 170  
 resistance, 158, 164  
 selection of, 173  
 "sentinel," 87, 157, 158  
 thermo-couple, 158 *et seq.*  
 Uehling, 158, 165  
 use of, 115  
 Wanner, 158, 166  
 water current, 158, 159, 165
- Pyrometers, accuracy of, 162, 167, 169, 171  
 calibration of, 87, 162, 164, 170  
 checking for accuracy, 87  
 conspectus of, 158  
 deterioration of, 87, 162, 165, 169  
 discrimination of, 162, 164, 166, 167,  
 169, 171  
 limits of ranges, 158, 161  
 responsiveness of, 164, 171
- Pyrometry, 155 *et seq.*
- Pyrometry, optical, 165 *et seq.*  
 recent developments in, 163
- Quality of material, effect on cutting speed, 235,  
 240, 241
- Quenching agents, 97  
 air, apparatus for, 84  
 cautions as to, 100  
 methods, 97, 114, 116  
 methods in connection with barium  
 chloride process, 114, 116  
 oil, apparatus for, 99  
 kind of oil to use, 99  
 methods of, 99  
 slender tools, 100  
 special methods, 102  
 water, 53, 97
- Quivering, in metal cutting (see also Vibration; and  
 Chatter), 213
- Radiation, black body, 171  
 pyrometer — see Pyrometer
- Rake, in case of internal cutting tools, 247  
 milling cutters, 267-269  
 lack of, in reamers, 249
- Range of utility of high-speed steel, 186 *et seq.*
- Ranges of pyrometers, 158, 161
- Rapid production — see Maximum production  
 reduction, use of multiple tools in, 246  
 steels (same as high-speed steels), 13
- Razors, high-speed, 19, 208
- Reamers, adjustable or expansion, 271, 272  
 clearance and relief in, 272  
 design of, 270  
 efficiency of, 199  
 floating,  
 grinding of, 142, 145, 148  
 hand, 201  
 inserted cutter (see also Design of tools;  
 Composite tools; Compound tools;  
 etc.), 200, 271  
 nature of work of, 272  
 quenching of, 100  
 speeds and feeds for, 248, 249  
 tempering of, 127  
 wear of, 199  
 welded blade, 184
- Reaming, coring, and displaced by drilling, 190, 197
- Re-annealing tools, 76
- Recalescence — see Critical points
- Recarburizing, in Bessemer process, 11
- Reciprocating machines, breakage of tools in, 194  
 high-speed tools and, 193  
 limitations of, 290  
 remodeling drives of, 298  
 rotary cutting and, 194,  
 212, 292  
 stripping of gears in, 298  
 tendency away from use  
 of, 212
- Records, temperature, forms of, 76, 177  
 tool making, 178
- Red-hardness, 41, 42, 47, 121  
 manganese and, 44  
 production of, in high-speed steel, 332  
 range of, Frontispiece, 41

- Red-shortness, 23  
 Reduplication of tools, 179  
 Refinement of method in the manufacture of high-speed steel, 61  
 Refinement of method in the manufacture of high-speed tools, 78  
 Refractory materials, high-speed tools and, 303, 323  
   milling of, 196  
 Re-grinding — see Grinding  
 Regulation of temperature — see Temperature regulation  
 Relation of tool and work, 212  
 Relief in reamers, 272  
 Re-making worn tools, 185  
 Remodeling of machine tools — see Machine tools  
 Repair of broken tools — welding, 184  
 Repetitive work, production of, 277  
 Resistance pyrometer — see Pyrometer  
 Responsiveness of pyrometers — see Pyrometers  
 Reversion, austenite to pearlite, 31, 33  
 Revolutions per minute, table for determining, 334  
 "Riding" of tool against flank of work, 258  
   tools, 226, 244, 247  
 Rigidity in machine tools, 212, 279  
   tool holders, 262  
     rests, 285  
     securing in remodeling of machines, 298  
 Ring turret lathe, 278  
 Riveting dies, 207  
 Rock drilling, high-speed steel in, 211  
 Rolling high speed steel bars, 61  
 Rose reamers — see Reamers  
 Rotating tools, composite — see Design of tools  
 Rotary cutting compared with reciprocating cuts (see also Reciprocating machines), 194  
 Rough forging and heavy grinding compared with close forging, 73  
   surfaces, prevention of, on certain tools, 181  
 Roughing cuts, speeds in, 245  
   tools, tempering of, 127  
 Routing of pieces in process, 322  
 Run, length of, a factor in cutting speed, 241  
 Running speed of grinding wheels, 138  
   time, standard, 230  
 Sandstone wheels for tool grinding, 148  
 Sawing high-speed steel, 65, 185  
   operations, 201  
 Saws, grinding of, 144  
   high-speed, 202  
   inserted tooth, 265, 267  
 "Scaling," causes of, 95  
   see also Oxidation  
 Scrapping of machine tools (see also Machine tools), 207, 295, 303, 304, 308  
   material in process, minimizing of, 303, 304, 306, 327  
 Screw machine tools, hardening and tempering of, 96  
 Self-hardening steels — see Mushet steel  
 Self-sharpening of tools (see also Non-clearance tools), 215, 216  
 Self-treatment (low-heat) of high-speed tools, 102  
 Semi-high-speed steels, 49, 50  
 Sentinel pyrometer, 87, 157  
 Separating stock from bar, 65, 185  
 Shank, strength of, in reamers and similar tools, 271  
 Shanks of twisted drills, 274  
 Shape of tool, influence on cutting speed and efficiency, 235, 253  
 Shaper operations, cutting speeds in, 250  
   tools, 194  
 Sharp tools, advantages in using, 152  
 Sharp-angle tools, Hartness type, 216, 242, 257, 287  
 Shaving, high-speed, 19, 208  
 Shaving or chip, nature and formation of, 215 *et seq.*  
 Shear blades, composite or compound, 184, 203  
   hardening temperature, 96  
   tempering of, 128  
   steel, 7  
 Shearing action in chip formation, 218 *et seq.*  
   nature of, 219  
   operations, use of high-speed tools in, 203  
 Shears, design of, 274  
   high-speed, 203  
 Shop organization — see Organization  
 Shrinkage, in hardening, allowance for, 181  
   minimizing in barium chloride process, 117  
 Side slope in lathe tools, 257  
 Silicon, function of, in steel manufacture, 45  
   influence in steel, 23, 45  
 Size, allowance for loss in grinding, etc., 180  
 Slender tools — see Tools  
 Slide rule, Barth, 236-237  
 Slide rule, use of, in solution of rapid production problems, 310  
   standardizing cutting operations, 236  
 Slotter and similar tools (see also Reciprocating machines), 194  
 Slotting, use of saws for, 202  
 Smelting, prehistoric, 1  
 Smoothness of tool surface, securing, 181, 182  
 Snap dies, 207  
   hardening temperature, 97  
   tempering, 128  
 Sodium carbonate (soda ash), 113  
 Soft metals, cutting of, 211  
   rake for milling cutter teeth, in cutting, 269  
   speeds on, 245  
 Softening of tool edges in metal cutting, 224  
 Solidity in machine tools, 212, 279, 280  
 "Special" high-speed steels, 50  
 Special tools, use of, in preference to standard, 261  
 Speed, accelerated, in planing machines, 292  
   changes in machine tools, 278, 287, 290  
   remodeled machines, 296  
   gains in newer types of reciprocating machines, 194  
   meter, use of, 239  
   tables, Taylor standard, 339  
     too fast?, 239  
 Speeds, cutting — see Cutting speeds  
 Spindles, in remodeled machines, 298  
   use of hollow, 283  
 Splitting of drills, 273  
 Sponge iron, 3  
 Stamping or nicking tools, 76, 185  
 Standard running time, 230  
   tools (see also Tools), 255  
   Taylor, 259



- Standardization of tools (see also Tool design; and Tool supply), 238 *et seq.*
- Standardizing depth of cut, 238  
jobs, 328
- Steel, bessemer, 9-11  
blister, 7  
carbon, 23  
composition of, 24  
microscopic structure of, 26  
cast, 8  
cementation, 7  
composition of — see Steels, below  
constituents of, 25-38  
crucible, 3, 8  
early manufacture and use of, 3-4  
revival of method of manufacture, 8  
cutting speeds in drilling, 249  
milling, 250  
on, 244, 245
- Damascus, 3, 4, 8  
definition of, 22  
development of, 7, 13  
double or double shear, 7  
electric, 12  
fixing the several states, 33  
for universal use, 47  
high-speed — see High-speed steel  
"intermediate," 49  
influence of the several ingredients, 32-45  
manganese-bessemer, 13  
manufacture, discovery and development of  
methods, 1 *et seq.*  
methods of modern, 8 *et seq.*  
modern science of, 7  
primitive methods of, 1-4  
production of uniform quality, 5
- mushet — see Mushet steel
- nickel, 23
- non-tungsten, 51  
open hearth, 9  
prevention of defects in, 23  
properties of, 22, 40  
theory of hardening, 25 *et seq.*
- tungsten (see also High-speed steel; Mushet steel; etc.), 13, 23
- Steels, air-hardening, 13  
alloy, 22  
ancient, defects of, 5  
remarkable properties of, 5  
similarity to modern steels, 7  
composition of carbon, 23, 24  
high-speed or air-hardening, 25, 46, 330  
"intermediate," "semi-high-speed," "special," etc., 50, 330  
mushet or self-hardening, 23, 24, 46  
variations in, 24  
microscopic structure of, 26 *et seq.*  
nomenclature of, 22  
rapid (same as high-speed), 13  
self-hardening — see Mushet steel  
semi-high-speed, 49  
"special," 49
- Steels, variations in quality of primitive, 5  
water hardening, 22, 51, 53, 97
- Steady rest, use of, 242
- Stiffness of tool, influence of, on cutting speed, 236
- Stock, heavy, recommended for high-speed tools, 252  
separating from the bar, 65, 185
- Stocks, lathe, 281, 284
- Stone cutting, high-speed tools for, 211  
to use in tool grinding, 134
- Stop watch, use of, in standardizing jobs, 239
- Storage, auxiliary (materials in process), relation to rapid production, 312  
of materials a factor in rapid production, 237
- Strains, effects of, 93  
guarding against, in tool making, 76  
internal, development of, in tools, 61, 65, 68, 93, 97, 118, 125  
torsional, in machine tools, 286
- Strength of structural forms, relative, 279
- Stresses, feeding or traverse, 289  
on high-speed tools, 19, 252  
tool, in sharp-angle tools, 259  
lip slope and, 257  
relation of cutting angle to, 256
- Structural forms, relative strength of, 279
- Sulphur, effect of, in steel, 23  
in high-speed steel, 45
- "Superior" high-speed steels, 51
- Super-heat treatment (see also High-heat treatment), 15
- Supervision, intelligent, and effective use of high-speed tools, 310, 317, 318, 320
- Swedish iron, 28  
in high-speed steel, 62
- Table traverse — see Traverse
- Tantalum, nature of, and influence in high-speed steel, 44
- Taps and dies, threading, breakage of, 201  
cutting speed of, 249, 250  
cutting the threads, 181  
design of, 201  
efficiency of, 201  
hardening by the barium chloride process, 117, 118  
temperature, 96  
prevention of rough surface on, 189  
tempering of, 127
- Taylor, Fred W., develops the high-heat treatment for tungsten steels, 20  
doctrine of re-grinding tools, 303  
experiments with mushet steels, 15  
formulas for metal cutting operations, 236  
on the hardening of high-speed tools, 101, 332  
standard cutting speeds, 238, 339  
tools, 242, 255, 259  
"The Art of Cutting Metals," Introduction, 332
- Taylor-White method of hardening, 101, 332

- Taylor-White process as a factor in the development of tool steels, 8  
 development of, 14  
 essentials of, 101  
 the high-heat treatment, 15, 101
- Tearing action in chip production, 221
- Teeming, in the manufacture of high-speed steel, 58-59
- Teeth, number of, in milling cutters, 195, 268, 269
- Temper colors, 37
- Temperature and color, relations of, 93, 124, 155, 156, 166  
 annealing range, 131, 132  
 "cold end," maintenance of, 163, 164  
 cones ("sentinel pyrometer"), 87, 157  
 control in barium chloride process, 107  
 determination, 155  
   colors and, 93, 124, 155, 156, 166  
   eye and, 93, 124, 155  
   personal equation in, 171  
   see also Temperature indication, below  
 effects of, unsuitable, 61  
 fluctuations in barium chloride bath, 115  
   oven and other furnaces, 107  
 forging, 69  
 gages, adaptation to purpose, 157  
   conspectus of, 158  
   need for, 86  
   ranges of, 158  
   see also Pyrometer  
 hardening, limits of, 93, 96  
   in pre-heating, 116  
   range of, Frontispiece, 15, 41  
   regulation of, 86, 93, 174  
   permissible variations in, 97  
   summary of, 96  
   see also under particular tools  
 indication, distant, 160, 169, 173, 175  
 measurement, uncertainty of, 124  
 range in red-hardness, Frontispiece, 41  
   hardening, Frontispiece, 15, 41, 93, 96, 97  
 records, form of, 176, 177  
 reduplication of, 169  
 regulation in barium chloride process, 113-115  
   coke furnace, 68  
   system of, 86, 174  
   value of data, 175  
 rolling or "finishing" high speed steel bars, 61  
 tempering, 127  
   range in, 121, 122
- Tempering, 121  
 a heat treatment, 29  
 alloy bath method, 123
- Tempering and the low-heat treatment, 122  
 electrical, 126  
 furnaces, 122  
 importance of data and method, 137  
 in oil, 38, 124  
 nature of process, 37  
 oil required, 126  
 purpose of, 35  
 range of temperatures, 15, 37, 127  
 temperatures, summary of, 127  
 the "new" high-speed steels, 121  
 time required for, 123, 125  
 See also under particular tools
- Test record form, 324
- Tests, the making of, 319
- Thermo-couple pyrometer, 158, 159, 169  
 pyrometry, recent developments in, 163
- Thermometer, mercurial, where used, 157
- Threading tools — see Taps and dies
- Time-labor, a factor in efficiency, 252
- Time necessary in annealing, 61, 130, 131, 132  
 of cutting, when relatively short, 238  
 required for cutting, diagram for determining, 336  
   tempering, 123, 125
- Tire turning, 213, 300
- Titanium, cost of, 62  
 influence in steel, 43
- Tool base, need for true, 76  
 truing of, 76, 228  
 cost — see Cost of tools  
 efficiency — see Efficiency  
 holder stock, use of, 61, 65, 182, 261  
 holders, design of, 261, 262  
   limitations and use of, 182, 262  
 holding, 285  
 position, modification of, in remodeling machines, 299  
 pressure on, in cutting (see also Stresses), 19, 252  
 problem, 322  
 quality of, effect on cutting speed, 241  
 relation to work, 212  
 rests, design of, 285  
 room, organization of, 152, 312, 315, 317  
 sections, special, 253  
   standard, 252-253  
 self-sharpening of (see also Non-clearance tools), 215, 216  
 steel, cutting speeds and feeds in drilling, 249  
 supply and maintenance, 315  
 support, in cutting operations, 228  
 tests, 319
- Tools, breakage of, 140, 194, 199, 201, 298  
 brazed and welded (see also Composite tools; and Compound tools), 182  
 broad-nosed, tendency to chatter, 255  
 chilled roll turning, 245  
 compound (see also Compound tools; Composite tools; and under particular tools), 182, 263  
 composite — see Compound tools; Composite tools; Welding; Tool holders; etc.  
 design of — see Design of tools  
 deterioration of blanking dies, 204

- Tools, displacement of old, by high-speed, 317
- dulling of, 152
    - earliest, 1
    - effect of using dull, 152
    - efficiency — see Efficiency; and under particular tools
    - endurance limits of, 6
    - forging of, 64
    - form, relation to chattering, 226
    - grinding system, 315, 322
    - "guttering" of, 222-223
    - handling of, in barium chloride process, 118
    - Hartness non-clearance — see Non-clearance tools
    - high-speed, beginning the use of, 319
      - comparative cost of, 20, 195
      - conditions affecting efficiency, 188
      - conservatism in the use of, 303
      - considerations affecting the use of, 306
      - cost of — see Cost of tools
      - economy in the use of, 300
      - efficiency (see also under particular tools), 20
        - on cast iron, 190
      - especial field for, 187, 303
      - hand, 200
      - handling of, 308
      - heavy cutting and, 188
      - limitations of, 187, 207
      - manufacture of, especial care required in, 67
        - or purchase of, 64, 134, 155, 308, 309, 317, 318, 322
      - position in industrial engineering, 300
      - problems affecting the use of, 315
      - reciprocating machines and, 193
      - relative economy of, 186
    - inserted cutter — see Composite tools; and under particular tools
    - keeping sharp, 151
    - lathe, broad-nosed, 254
      - compound high-speed-carbon, 183
      - grinding of, 142
      - Hartness non-clearance (see also Non-clearance tools), 257
      - Taylor standard, 242, 255, 259
      - tempering of, 127
    - maintenance, 322
      - cost, 192
    - manufacture or purchase of, 64, 134, 155, 308, 317, 318, 322
    - multiple, use of, in rapid production, 246
    - nickling or marking, 76
    - non-clearance — see Non-clearance tools
    - planer, 194
    - progressive dulling of, 152
    - purchase or manufacture of, 64, 134, 155, 308, 317, 318, 322
    - reduplication of, 179
    - repair of broken, 184
- Tools, "riding" of, in cutting operations, 226
- self-sharpening — see Non-clearance tools
  - shaper, 194
  - sharp, advantage in the use of, 152
  - sharp angle, use of (see also Non-clearance tools), 286
  - slotter, 194
  - standard, 255
  - standardization of, 238, 315
  - supplying to workmen, 312
  - Taylor standard, 242
  - threading — see Taps and dies
  - "warming up" of,
    - wear of, 199, 223, 224, 227
    - worn, remaking of, 185
- Toledo steel, 3, 5
- Tongs, special forms of, 87, 94, 118, 119
- Topping ingots, 62
- Torsional strains in machine tools, 279, 286
- Toughness, restoration of, in hardened tools, 121
- Transportation of material in process — see Material
- Traverse, factors affecting, 242
  - in milling aluminum, 250
  - operations, 250
  - or feed, table for determining, 334
- Troostite in high-speed steel, 43
  - nature of, 38
- Truing grinding wheels, 138
  - tool bases — see Tool bases
- "Try outs," 324, 328
- Tungsten a fixing agent, 41
  - and self-hardening steels, 40
  - cost of, 62
  - effect of, on hardening, 40
  - influence in high-speed steel, 44
  - steels, effect of tempering on, 41
    - properties of, 13
- Turning locomotive tires, 213, 300
- Turret lathe, Foster ring, 278
- Twist and twisted drills — see Drills
- Type metal for anchoring inserted cutter blades, 267
- Uehling pyrometer, 158, 165
- Unannealed stock, use of, 261
- Uniformity in tools, securing, 78
  - lack of, in material, effect on standard speeds, 241
- Universal adaptation of high-speed steel, 211
- Uranium, influence in steel, 43
- Utility of high-speed steel, range of, 186 *et seq.*
- Universal use, high-speed steel for, 47
- Vanadium, cost of, 62
  - influence in steel, 43
- Variables affecting efficiency, 235
  - in metal cutting, nature of, 240
- Venting of gas furnaces, 111
- Ventilation of hardening plant, 88
- Vibration and chatter, 226
  - elimination of, in machine tools, 278, 280
  - in metal cutting, causes and nature of, 213, 214
  - lateral, 214
    - in Hartness tools, 258
  - minimizing, 215, 285

- Wage system, relation to efficient use of high-speed tools, 310  
    maximum production, 321
- Wanner pyrometer, 158, 166
- "Warming up" of tools in cutting operations, 102
- Warner cut meter, 240
- Water as a quenching or cooling agent, 53, 97  
    current pyrometer, 158, 159, 165  
    hardening high-speed steels, 51, 53
- Wear of cutting tools, 199, 223, 224, 227  
    reamers, and like tools, 199
- Web of twist drill, design of, 273
- Weight essential in high-speed machine tools, 280
- Welded (compound) tools, 183, 263  
    shear blades and dies, 203  
    utility of, 184
- Welding high-speed steel to carbon steel, 182, 184  
    in repairing broken tools, 184  
    lathe beds and head stocks, 282
- Wet or dry grinding of tools, 136, 148
- Whale oil for the quenching bath, 100
- Wheel, kind to use in tool grinding, 134, 137, 142
- Wire drawing, dies for, 206
- Wolfram — see Tungsten
- Wood working, high-speed tools in, 209  
    operations, finish obtained with high-speed tools, 209  
    tools, design of, 274  
    efficiency of, 210  
    tempering, 128
- Wootz, 3
- Work and tool, relation between, 212
- Workman, the, a factor in rapid production, 317, 321  
    attitude toward high-speed tools, 310  
    consideration for, in accelerated production, 310  
    endurance limit of, 304, 310, 317  
    training in the proper use of high-speed tools, 310
- Worn tools, re-making of, 185















YC 34186

311743

7.5320

Becker

B3

Mining

Dept.

UNIVERSITY OF CALIFORNIA LIBRARY

