



371.426

B47h

Keep Your Card in This Pocket

Books will be issued only on presentation of proper library cards.

Unless labeled otherwise, books may be retained for two weeks. Borrowers finding books marked, defaced or mutilated are expected to report same at library desk; otherwise the last borrower will be held responsible for all imperfections discovered.

The card holder is responsible for all books drawn on this card.

Penalty for over-due books 2c a day plus cost of notices.

Lost cards and change of residence must be reported promptly.



Public Library
Kansas City, Mo.



DATE DUE

JUN 25 '58

Suz

SWINNEY

JUN 27 '58

98

Jan 25, 63 Hazlett

From the collection of the

o ^{z n m} Prelinger ^a Library
v _{t p}

San Francisco, California
2006





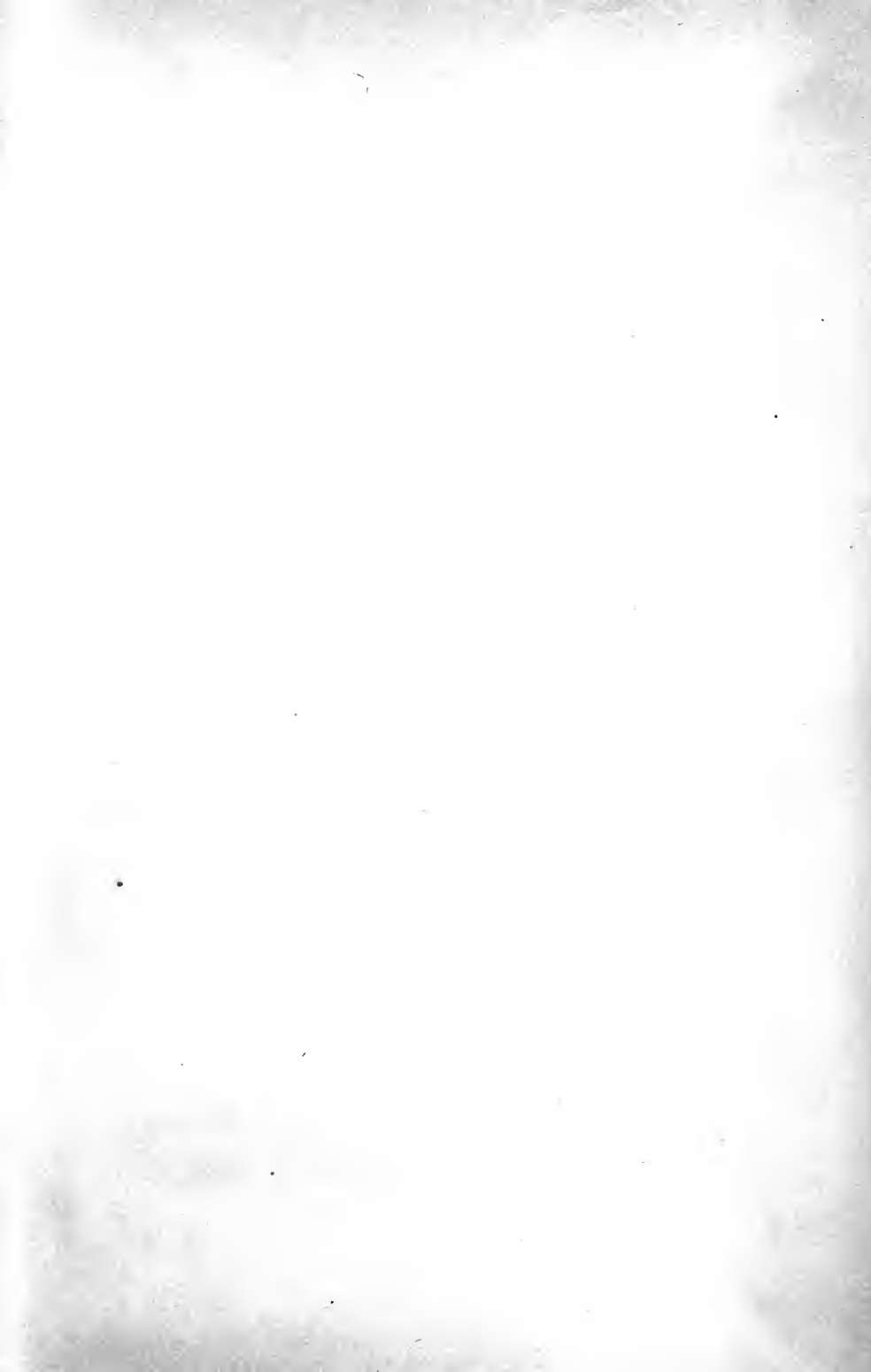

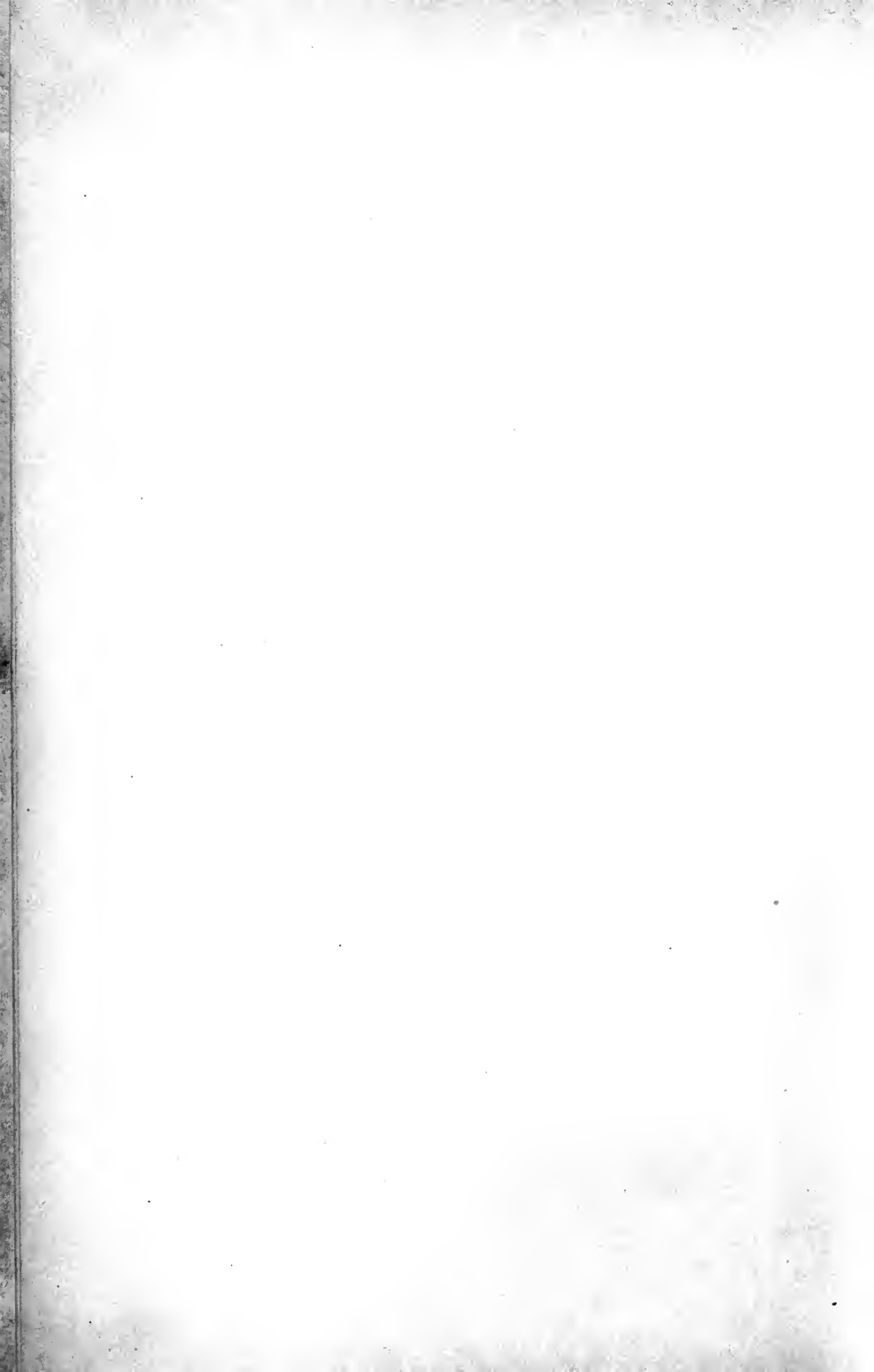

HISTORY of MANUAL
and INDUSTRIAL
EDUCATION
1870 to 1917

By

CHARLES ALPHEUS BENNETT

*Editor of Industrial Education Magazine
Formerly Professor of Manual Arts, Bradley
Polytechnic Institute*



THE MANUAL ARTS PRESS

Peoria, Illinois

Red

WANGLI DUBIN
VTD SABIAN
03

COPYRIGHT, 1937
CHARLES A. BENNETT

371.426
B47h

BINNED NOV 3 1951

Printed in the United States of America

mc clurg 4⁰⁰

No 23 '35

932135

PREFACE

THIS volume covers a well-defined period of development in manual and industrial education. It begins with the analysis of the mechanic arts for teaching purposes and ends with the interruption caused by the World War in Europe and with the passage of the National Vocational Education Act in America. It begins where the earlier volume by the same author, *Manual and Industrial Education up to 1870*, left off and continues the subject until another vital change has taken place.

In this, as in the earlier volume, an effort has been made to consult the best available sources and select facts that seem to be significant. In the selection, there has been no conscious effort to uphold any particular theory of manual or industrial education. Instead, the aim has been to give facts and the opinions of men of recognized standing. The reader is left free to draw his own conclusions.

However, an effort has been made to present facts in their proper setting and to help the reader to avoid misinterpretations. To assist in this, as a rule, the terminology of the time under consideration has been used: such terms as sloyd, manual training, manual arts, industrial school, industrial arts are used with the meanings generally understood at the place and time under consideration.

In reference to the field covered, it should be stated that no attempt has been made to include the history of manual and industrial work in all countries. The purpose has been to set forth the most significant types of work wherever found, and especially those that have exerted the widest influence.

Concerning the references at the end of each chapter, it should be noticed that only the source references actually used are given. These represent merely a fraction of the sources consulted. To some readers, it may seem strange

that certain American publications are not referred to oftener. The reason for this is that, in the case of work done in foreign countries, the American publications have often been quite largely digests of foreign reports, and it has seemed more desirable, whenever possible, to consult the original sources. A notable example of such a source is the British Report of Royal Commissioners on Technical Instruction of 1884. This five-volume publication has furnished much data for other publications ever since that time.

The illustrations of European work were made from photographs taken by the author and published in a series of articles in the *Manual Training Magazine*, Vols. XI, XII, and XIII, and from reports, pamphlets, and courses of instruction collected from time to time. Most of the illustrations of early American work have been taken from annual reports of the Massachusetts Board of Education.

Thanks are due to many persons who have assisted in the preparation of this volume by answering letters, sending needed information, checking names and dates, and sometimes even copying parts of official reports. Special acknowledgment for reading manuscript, criticisms, and valued suggestions are due the following:

Dr. Frederick C. Whitcomb, Miami University, the first five chapters; James T. Baily, Welwyn Garden City, Herts, formerly secretary of National Association of Manual Training Teachers of England, and John Cooke, Bristol, England, retired National Inspector of Handicraft, England, Chapter VII; William E. Roberts, until his retirement, supervisor of manual arts, public schools, Cleveland, Ohio, Chapter X; Frank M. Leavitt, assistant superintendent of public schools, Pittsburgh, and Edward C. Emerson, associate director of manual arts, Boston, Chapter XI; and Dean Albert F. Siefert, Bradley Polytechnic Institute, Chapter XII.

For reading and translating parts of several French and German books and reports, I am indebted to my son, Professor Howard G. Bennett of the University of Vermont.

CHARLES A. BENNETT

April, 1937

CONTENTS

	PAGE
PREFACE	3
ILLUSTRATIONS	9
CHAPTER I. THE RUSSIAN SYSTEM OF TEACHING THE MECHANIC ARTS.	13
<p>1. Analysis of processes. 2. The origin of the Russian system. 3. General principles of the system. 4. Equipment of the shops. 5. Courses of instruction. 6. Methods of teaching. 7. Some results of the Russian system. 8. An early school of mechanic arts. 9. Conclusion. Source material: I, A—The Russian system of workshop instruction as shown at the Centennial Exposition in Philadelphia in 1876. I, B—The school at Moscow. Source references.</p>	
CHAPTER II. THE SLOYD OF SCANDINAVIA.	53
<p>10. Home sloyd. 11. Early sloyd schools. 12. Sloyd in the folk schools of Finland. 13. Sloyd in the normal school established by Cygnaeus. 14. Salomon and the schools at Nääs. 15. Educational sloyd. 16. General characteristics of educational sloyd. 17. The aims of educational sloyd. 18. Equipment for Swedish sloyd. 19. The sloyd models. 20. Method of teaching. 21. The far-reaching influence of Salomon. 22. Primary sloyd. 23. Danish sloyd. Source material: II, A—The decline of home sloyd. II, B—Sloyd in the common schools of Finland. Source references.</p>	
CHAPTER III. MANUAL TRAINING IN FRANCE.	107
<p>24. The historical background. 25. The Salicis school. 26. Manual training in the elementary schools. 27. Teachers of manual training. Source material: III, A—Manual training in the public elementary schools. III, B—Manual training instruction in the elementary schools of Paris. Source references.</p>	
CHAPTER IV. TRADE AND TECHNICAL EDUCATION IN FRANCE	146
<p>28. The beginnings of a national policy. 29. National industrial schools. 30. The national system of vocational schools. 31. The municipal trade schools of Paris. 32. National schools of trades and industries. 33. Evening schools. Source material: IV, A—A system of apprenticeship schools. Source references.</p>	

	PAGE
CHAPTER V. THE DEVELOPMENT OF MANUAL TRAINING IN GERMANY.	169
34. Manual training and German pedagogy. 35. The beginning of the manual-training movement in Germany. 36. The German association for boy's handwork. 37. The Leipsic method. 38. Leipsic a center of influence. 39. Manual training in Munich. Source references.	
CHAPTER VI. TRADE AND TECHNICAL EDUCATION IN GERMANY.	193
40. General statement. 41. Industrial continuation schools. 42. The industrial continuation schools of Munich. 43. Trade schools and secondary technical schools. 44. Industrial art schools. Source material: VI, A—Subjects of study in the industrial continuation schools of Germany. VI, B—Basic considerations in organizing continuation schools. VI, C—German trade schools as a substitute for apprenticeship. Source references.	
CHAPTER VII. MANUAL TRAINING IN ENGLAND.	220
45. The background. 46. Public elementary schools. 47. Industrial schools. 48. Shopwork in secondary and technical schools and colleges. 49. Shopwork begins in board schools. 50. The development of the manual-training idea. 51. Manual training in London under the "joint committee." 52. The early influence of Swedish sloyd. 53. Sloyd efforts to gain official recognition. 54. Typical equipments and courses of instruction. 55. Association of teachers and their publications. 56. The training and certificating of teachers. 57. Elementary handwork. Source material: VII, A—Manual training under joint committee of school board of London and city and guilds of London Institute. Source references.	
CHAPTER VIII. TECHNICAL EDUCATION IN ENGLAND.	275
58. Use of the term "technical education." 59. The great awakening. 60. The science and art department. 61. The city and guilds of London Institute. 62. The London polytechnics. 63. The typical English technical school. 64. The National Association for the Promotion of Technical and Secondary Education. 65. Arts and crafts schools. 66. Junior technical schools. Source material: VIII, A—Trade schools of London. Source references.	
CHAPTER IX. THE EARLY DEVELOPMENT OF PEDAGOGICALLY ORGANIZED SHOPWORK INSTRUCTION IN THE UNITED STATES OF AMERICA	310
67. Shopwork in the Worcester County Free Institute. 68. Early shopwork at the Kansas State Agricultural College. 69. Professor Woodward's early experiments in school shopwork. 70. Impressions made by the Russian exhibit in 1876. 71. The School of Mechanic Arts in	

Boston—Course in vise work—Course in forging—
Course in woodworking. 72. Educational value of instruction in the mechanic arts. 73. Professor Woodward's vision of a manual-training school. Source material: IX, A—
The manual element in education. Source references.

CHAPTER X. MANUAL TRAINING IN SECONDARY SCHOOLS 347

74. A new type of high school. 75. A period of controversy. 76. Variations from the original type of manual-training high school. 77. Manual training in general high schools. Source material: X, A—The teacher of tool work. Source references.

CHAPTER XI. MANUAL TRAINING IN ELEMENTARY SCHOOLS 402

78. An experiment in Boston. 79. Testing new theories in New York City. 80. Manual training given public support in Montclair. 81. Other early experiments. 82. Typical grammar-grade course developed in Boston. 83. Influences tending to modify the grammar-grade manual training. 84. Industrial arts. Source material: XI, A—
Hand education as an essential part of school education. XI, B—Manual training in the common schools. Source references.

CHAPTER XII. TEACHER TRAINING AND ASSOCIATIONS OF TEACHERS 464

85. Beginnings of manual training in normal schools. 86. A professional course developed at Teachers College. 87. The Sloyd Training School in Boston. 88. Special courses in state normal schools. 89. Teacher training in privately endowed institutions. 90. Teacher training in universities. 91. Professional associations of teachers. Source references.

CHAPTER XIII. THE VOCATIONAL EDUCATION MOVEMENT 507

92. Before 1906. 93. The report of the Massachusetts Commission. 94. The National Society for the Promotion of Industrial Education. 95. The New York State report. 96. New schools to meet new conditions. 97. Vocational guidance. 98. State legislation for vocational education. 99. The National Vocational Education Law. Source references.

SIGNIFICANT DATES 553

INDEX 559

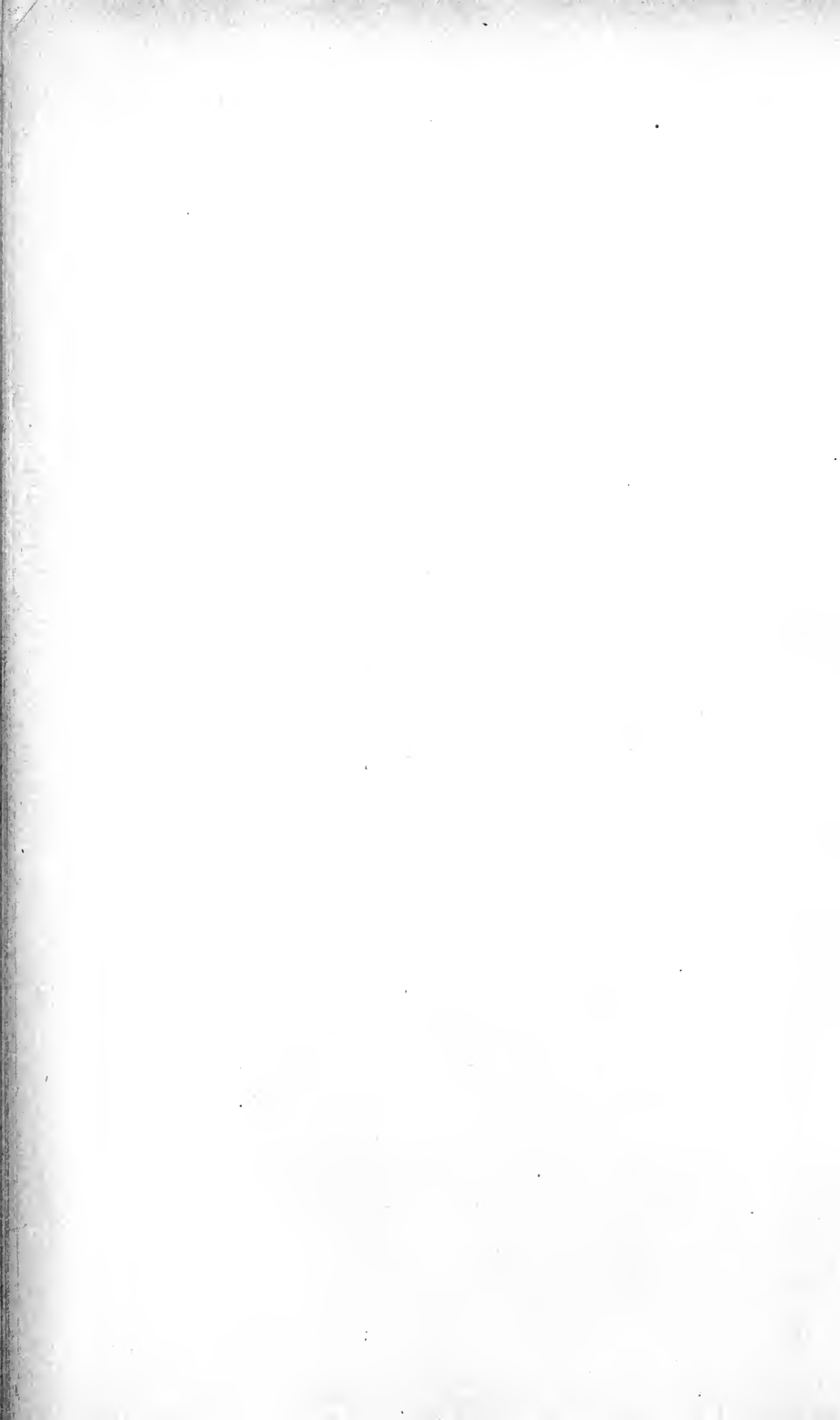

LIST OF ILLUSTRATIONS

	PAGE
Fig. 1. Imperial Technical School, Moscow, Russia	15
Fig. 2. Victor Della Vos	16
Figs. 3-20. Working Drawings of Tool Exercises in the Russian System	21-39
Fig. 21. Floor Plan, Royal Mechanic Arts School, Komotau, Bohemia	43
Fig. 22. Royal Mechanic Arts School, Komotau, Bohemia	44
Fig. 23. Otto Salomon	63
Fig. 24. Sloyd School Bench Designed at Nääs	69
Fig. 25. Sloyd Room at Nääs	70
Fig. 26. Floor Plan of Sloyd Room, Stockholm	71
Figs. 27-35. Working Drawings of Swedish Sloyd Models	73-81
Fig. 36. Metal Sloyd Room, Stockholm	89
Figs. 37-39. Metal Sloyd Models, Stockholm	90-92
Fig. 40. Eva Rodhe's Primary Sloyd Room, Gothenburg	93
Fig. 41. Four "Life-Form" Models Used by Eva Rodhe	94
Fig. 42. Jointed Annual Toys Designed by Eva Rodhe	95
Fig. 43. Models Ornamented by Countersunk Holes	96
Fig. 44. Salicis School	110
Fig. 45. Workshop Building, Salicis School	111
Fig. 46. Workshop, Salicis School	112
Fig. 47. Drawing Room, Salicis School	113
Fig. 48. Woodworking Course, Salicis School	115
Fig. 49. Wood-turning Course, Salicis School	116
Fig. 50. Metal Filing and Fitting Course, Salicis School	117
Fig. 51. Wood-carving Course, Salicis School	118
Fig. 52. Clay-modeling Course, Salicis School	119
Fig. 53. Working Drawing, Salicis School	120
Fig. 54. Beginning Course in Woodworking Recommended by René Leblanc	124
Fig. 55. Advanced Course in Woodworking Recommended by René Leblanc	125
Fig. 56. Course in Raised Sheet Metal Recommended by René Leblanc	126
Fig. 57. Workshop, Public School, Rue St. Maur, Paris	127
Fig. 58. Workshop Building, Public School, Rue St. Maur, 1909	128
Fig. 59. Metalworking Shop, Public School, Paris	129

	PAGE
Fig. 60. Part of Paris Exhibit sent to the Franco-British Exposition in London, 1900	130
Fig. 61. Required Woodwork, First Year, Normal Course	133
Fig. 62. Required Woodwork, Second Year, Normal Course	133
Fig. 63. Required Woodwork, Third Year, Normal Course	133
Fig. 64. Required Metalwork, Three Years, Normal Course	134
Fig. 65. Upholstery Shop in <i>École Boulle</i> , Paris	155
Fig. 66. <i>École Estienne</i> , Paris	157
Fig. 67. Shop Building, National School of Trades and Industries, Châlons-sur-Marne	162
Fig. 68. Woodworking Shop, National School of Trades and Industries, Châlons-sur-Marne	163
Fig. 69. Waldemar Goetze	173
Fig. 70. Training College for Teachers, Leipsic	175
Fig. 71. Leipsic Work in Paper-Box Making and Bookbinding	180
Fig. 72. The Leipsic Type of Woodworking Models	181
Fig. 73. Leipsic Metalwork and Experimental Apparatus	182
Fig. 74. Typical Drawing in the Leipsic Woodworking Course in 1909	183
Fig. 75. First Woodworking Exercises, Munich	186
Fig. 76. Advanced Woodworking Exercises, Munich	187
Fig. 77. Woodworking Shop, Flurstrasse Public School, Munich	188
Fig. 78. Metalworking Shop, Flurstrasse Public School, Munich	190
Fig. 79. Georg Kerschesteiner	196
Fig. 80. Liebherstrasse School, Munich	200
Fig. 81. Workshop for Art Smithing, Munich	202
Fig. 82. Wood-carving Shop, Munich	203
Fig. 83. Workshop, Beethoven Street School, London	235
Fig. 84. Kennington Road Center, London	248
Fig. 85. Models in Course at Kennington Road Center, 1909	250
Fig. 86. Workshop in Leicester	252
Fig. 87. Course in Woodwork for Elementary Schools, Leicester, in 1909	253
Fig. 88. Metalworking Center, Birmingham	254
Fig. 89. Elementary-School Course in Metalwork, Birmingham	255
Fig. 90. Metalworking Shop at Stanley Higher Elementary School, London	256
Figs. 91 and 92. Four-year Course in Metalwork, Higher Elementary School, London, 1909	257
Fig. 93. "Work Board" Equipment for Woodworking	268
Fig. 94. Graph Showing Growth of the Technology Department of the City and Guilds of London Institute	282
Fig. 95. City and Guilds of London Institute	283
Fig. 96. Quentin Hogg	286
Fig. 97. Regent Street Polytechnic, London	288
Fig. 98. Municipal School of Technology, Manchester	292

	PAGE
Fig. 99. Cotton Spinning Room, Manchester School of Technology	294
Fig. 100. Central School of Arts and Crafts, London	299
Fig. 101. Calvin M. Woodward	316
Fig. 102. John D. Runkle	321
Fig. 103. Tools for Course in "Vise Work," School of Mechanic Arts, Boston	323
Fig. 104. Course in "Vise Work"—Cold Metalwork	325
Fig. 105. Beginning Exercises in Course in Forging, School of Mechanic Arts, Boston	327
Fig. 106. Welding Exercises, Course in Forging, School of Mechanic Arts, Boston	328
Fig. 107. Toolmaking Exercises, Course in Forging, School of Me- chanic Arts, Boston	329
Fig. 108. Forge Shop, School of Mechanic Arts, Boston	332
Fig. 109. Wood-turning Shop, School of Mechanic Arts	332
Fig. 110. Course in Carpentry and Joinery, School of Mechanic Arts	333
Fig. 111. Course in Wood Turning and Patternmaking, School of Me- chanic Arts	334
Fig. 112. Manual Training School, St. Louis, 1880	349
Fig. 113. First-Floor Plan, St. Louis Manual Training School	350
Fig. 114. Second-Floor Plan, St. Louis Manual Training School	350
Fig. 115. Woodworking Shop, St. Louis Manual Training School	351
Fig. 116. Blacksmith Shop, St. Louis Manual Training School	352
Fig. 117. Machine Shop, St. Louis Manual Training School	352
Fig. 118. Time Table, St. Louis Manual Training School	354
Fig. 119. Chicago Manual Training School	374
Fig. 120. Joinery Course, Philadelphia Manual Training School	377
Fig. 121. Chipping and Filing Course, also Patternmaking Course, Philadelphia	378
Fig. 122. Tinsmithing and Forging Courses, Philadelphia Manual Training School	379
Fig. 123. St. Paul Manual Training School	381
Fig. 124. A Page from the Printed Course in Woodworking by W. F. Decker	395
Fig. 125. The First Eight of Twenty-four Exercises in Wood Carving, Used in Industrial School, Boston, 1874	405
Fig. 126. Course in Sloyd for Grammar Grades of Public Schools by Gustaf Larsson	433
Fig. 127. Woodworking Course, Seventh and Eighth Grades, Boston Public Schools, 1901	436
Fig. 128. Woodworking Course, Ninth Grade, Boston Public Schools, 1901	437
Fig. 129. Grammar-Grade Problems Designed or Adapted by Ira S. Griffith, 1912	444
Fig. 130. The Kind of Working Drawing Encouraged by Ira S. Griffith	446

	PAGE
Fig. 131. Typical Design Suggestions Used by Ira S. Griffith	447
Fig. 132. John Dewey	451
Fig. 133. Macy Manual Arts Building, Teachers College, New York City	469
Fig. 134. First-Floor Plan, Macy Manual Arts Building	471
Fig. 135. Floor Plans, Sloyd Training School, Boston	473
Fig. 136. Class of 1913, Sloyd Training School, Boston	474
Fig. 137. Portrait Bust of Gustaf Larsson	475
Fig. 138. Chart Showing Development of Association	497
Fig. 139. Charles R. Richards	519
Fig. 140. Charles A. Prosser	544

REFERENCE NUMBERS

Throughout this volume the reference numbers refer to the Source References at the ends of the chapters. The first number in the parenthesis is the number of the reference in the list. The last number is the page in the book referred to. In some cases, more than one page is indicated; in others, none is indicated. When the book consists of more than one volume, the volume number is indicated in Roman numerals and is placed immediately before the page number. In a few cases, page numbers are in Roman numerals because they refer to introductions to books, and these are often printed in Roman numerals. Source material numbers refer to the excerpts printed at the ends of the chapters. In these references, the Roman numeral indicates the chapter in this volume.—AUTHOR.

CHAPTER I

THE RUSSIAN SYSTEM OF TEACHING THE MECHANIC ARTS

1. **Analysis of Processes.** An important turning point in the history of manual and industrial education was reached when an adequate teaching analysis had been made of the tool processes and construction methods employed in the mechanic arts. This is true whether one thinks of manual arts as being taught for vocational purposes or as part of a general education. Before such an analysis was made, progress in teaching these arts was very slow; after that, progress was much more rapid. Before that time, the prevailing method of learning a manual art or trade was by the traditional imitative method of apprenticeship; after that time, the method began to be that of mastering the elements of the art, one or a few at a time, in progressive sequence from easy to difficult. When the idea of analyzing the manual arts into their elements and of arranging these elements in pedagogical order was shown to be possible and practicable, it was recognized that these arts could be taught in schools by essentially the same teaching methods as the other school subjects.

Just when and where such analyses of the manual arts were first made and by whom are somewhat uncertain, but it is definitely known that a very thorough analysis was made of geometric drawing for teaching purposes in Pestalozzi's school before 1824.¹ On the other hand, there is evidence that he did not make a corresponding analysis of the other manual arts² he tried to teach. An analysis of the process of sewing which resulted in a system of samplers and other progressively graded exercises, was worked out in England as early as 1847 for use in teaching girls in industrial schools.³

¹Bennett, C. A. *History of Manual and Industrial Education up to 1870*, p. 120.

²*Ibid.*, p. 122

³*Ibid.*, p. 236

But there seems to be no available evidence that any adequate analysis of the mechanic arts was made until 1868 when the Russian system of workshop instruction was devised by Della Vos and his associates for use in the Imperial Technical School at Moscow. Several of these arts had been taught under favorable school conditions in the National School of Trades and Industries at Compiègne, France, beginning in 1803,⁴ and later, in similar schools at Chalons, Aix, and Angers (1—XIII); in the Manual Labor Academy at Germantown, Pennsylvania, in 1829;⁵ and in the Technical School at Mulhouse, France, before 1865.⁶ According to the report of the French Commission of 1865, the national schools of trades and industries of France taught "the principal rules of each art,"⁷ but just what these rules were is not evident. In 1867, M. Roux, director of the Secondary Training College at Cluny, pointed out that, while work in the mechanic arts appeared to be very complicated, if closely examined it would be found that there were a small number of tools which were the types of all the others and that one who knew how to use these few had the foundation knowledge for numberless trades (2—8). In the same year, a French mechanical engineer, A. Cler, made "a collection of models for the practical study of the principal methods of forging and welding iron and steel, as well as the chief parts of joiners' work . . . with a purely demonstrative aim." (1—XX). None of these leanings toward a teaching analysis of the mechanic arts appears to be comparable to the analytical work done in Russia.

2. The Origin of the Russian System. In the year 1830, there was established in the City of Moscow a School of Trades and Industries. By the imperial decree of June 1, 1868, this school was reorganized, "raised to the rank of the leading polytechnic schools of Europe," and became known as the Imperial Technical School. (3—135) The course of instruc-

⁴Ibid., p. 276

⁵Ibid., pp. 187 and 206

⁶Ibid., pp. 284 and 298

⁷Ibid., p. 283

tion was six years in length. The purpose of the school was to train civil engineers, mechanical engineers, draftsmen, foremen, and chemists. (4—ix) The theoretical instruction is said to have resembled that given at the *École Centrale des Arts et Manufactures* in Paris. To supplement this theoretical instruction with the most thorough and effective practical instruction, extensive workshops were provided, Fig. 1, and “large contracts for actual work for private individuals” were taken by the school and carried out partly by hired workmen and partly by the students. (5—204) The

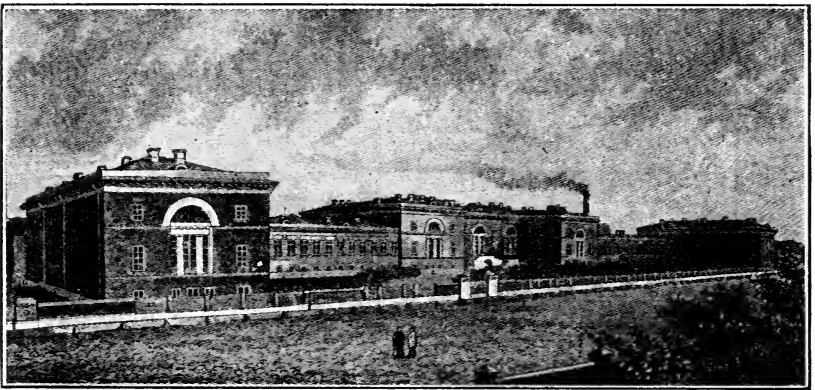

FIG. 1. IMPERIAL TECHNICAL SCHOOL, MOSCOW, RUSSIA

machines constructed included steam engines, pumps, agricultural machinery, etc. (1—xiv) Sometimes as many as one hundred paid workmen were employed in the various shops of this school. (5—205)

But the plan of having the students learn by the “no-teaching” or the merely imitative or the apprenticeship method then in vogue was not considered satisfactory. In fact, the consciousness of the lack of any effective system or method in the shop instruction led the director, Victor Della Vos, Fig. 2, and his shop instructors, in 1868, to work out a new system that involved the organization of *instruction shops* separate from the *construction shops* where orders for private individuals were filled. Students were permitted to work in the construction shops only after having completed the required course in

the instruction shops. (5—205) The end sought in the new system was to teach the fundamentals of the mechanic arts: (a) in the least possible time; (b) in such a way as to make possible the giving of adequate instruction to a large number of students at one time; (c) by a method that would give to the study of practical shopwork “the character of a sound, systematical acquirement of knowledge”; and (d) so as to



FIG. 2. VICTOR DELLA VOS
From Ham: *Manual Training*

enable the teacher to determine the progress of each student at any time. (Source Material I A, page 48). The reasoning of Della Vos was essentially this:

Everybody is well aware that the mastery of any art—drawing, music, painting—is readily attained only when the first attempts are subject to a law of gradation, the pupil following a definite method or school, and surmounting, little by little and by certain degrees, the difficulties encountered. For all these arts, a method of study has been worked out, since they have long constituted a part of the education of the well-instructed classes of the people, and must therefore of necessity have been subjected to scientific analysis with a view to discovering those conditions under which the learning of the

art may be as easy as possible. The same is not true, however, of such arts as carpentry, wood turning, metal turning, and forging which have been followed by the common and imperfectly educated classes of workingmen. There is not the slightest doubt as to the importance of working out a logical method of teaching these mechanic arts, not only for the benefit of the student of engineering, but for use in giving practical instruction to the working people as well. Such a method, too, would do much to perfect mechanical hand labor itself, which, on account of the introduction of special machinery, is year by year perceptibly deteriorating. (I—)

This line of thought clearly led Della Vos to devise a system involving class instruction and a new analysis of the arts he wished to have taught in his school.

3. General Principles of the System.⁸ The following facts or rules concerning the Russian system may be regarded as underlying principles:

(1) Each art or distinct type of work has its own separate instruction shop; e.g., joinery, wood turning, blacksmithing, locksmithing, etc.

(2) Each shop is equipped with as many working places and sets of tools as there are pupils to receive instruction at one time.

(3) The courses of models are arranged according to the increasing difficulty of the exercises involved, and must be given to the pupils in strict succession as arranged.

(4) All models are made from drawings. Copies of each drawing are supplied in sufficient number to provide one for each member of a class. The drawings are mounted on cardboard (or, for the blacksmith shop, on wooden boards) and varnished.

(5) The drawings are made by the pupils in the class for elementary drawing, under the direction of the teacher of drawing with whom the manager of the shops comes to an agreement concerning the various details.

(6) No pupil is allowed to begin a new model until he has acceptably completed the previous model in the course.

⁸The facts stated in this and the three succeeding sections, for the most part, are taken from statements dated 1893. It is, therefore, probable that they include some improvements on the system developed before 1876. However, a comparison of the early statements of courses and methods, so far as they are available, with those of 1893, make it clear that in essential elements there seems to have been no important change during the seventeen years.

He must receive at least a grade of three, which is considered good.

(7) First exercises will be accepted if dimensions are no more than approximately correct; later exercises should be exactly to dimensions; therefore, the same marks given a student at different periods during his course do not express the absolute, but the relative, qualities of his different pieces of work.

(8) Every teacher must have more knowledge of his speciality than is necessary merely to perform the exercises in the course of instruction. He must keep constantly in practice so that his work may be an example of perfection to his pupils. Such dexterity increases the authority of the teacher. (6—10, 14)

4. **Equipment of the Shops.** Each bench or working place for a single pupil was provided with a set of tools, kept in a well-lighted closet, with a wire netting front, so that the tools might be easily examined. Each tool closet was provided with lock and key. At the close of a lesson, each pupil must lock his tool closet and deposit the key in a key closet provided for the purpose. This was made with a glass or wire netting door, and contained a hook for each key. The bench sets did not contain all the tools necessary for some of the work; consequently a few extra tools for common use were placed on a board in the shop. Each tool on this board was numbered, also its place on the board. Any tool taken from this board was to be returned by the pupil as soon as he was done using it, or, at least, as early as the close of the day's work in the shop.

In every shop there hung:

(1) A board upon which were samples of the regular course of study pursued in that shop;

(2) A board to which was fastened one of the regular bench sets of tools, the name of each tool being on the board in large letters;

(3) Rules for the internal order of the shop, made by the manager of the shop and approved by the pedagogical conference;

- (4) A list of the benches, vises, furniture, machines, etc., constituting the equipment of the shop; and
 (5) The daily program of work.

The school was provided with models and charts to be used in explaining the form and action of various tools. Beginning in 1872, a feature of the school equipment was the large number of wooden models made and used for demonstration purposes: e.g., fourteen different types of drills, bits, and counter-sinks made six times their natural size; eight models of the cutting parts of files enlarged twenty-four times; ten models of screw-cutting tools enlarged six times. (1—23, 27)

5. **Courses of Instruction.** Each course of instruction consisted, in general, of a graded series of exercises without special reference to their application in the construction of useful articles. The teaching of the course, however, was divided into three successive periods. In the *first* of these, the pupils were given the names of the tools, told how to care for them and shown how to use them; they were taught the leading properties of the materials to be used, and given practice in fundamental methods of holding and using the tools. In the *second*, the pupils learned to combine the exercises of the first period, making, in the woodworking, a variety of typical joints used in construction. Metalworking was treated in a similar way, always proceeding from the simple forms to the more complicated. In the *third* period, the pupils made the whole or parts of various mechanisms and acquired an extended practical knowledge of working wood and metals. In both the second and third periods of instruction, parts of machines might serve as projects. These projects might be made full size or to scale.

During the course, the students learned to sharpen and set their tools, to care for and value measuring instruments, to know the nature of metals and the effect of fire on iron and steel, and to work from drawings. They acquired such related useful knowledge as they would need later when employed. (6—8)

An examination of a few of the exercise pieces in wood-working will give a good general idea of the character of all

the early exercises in any course under the Russian system.

The material used in the first exercise consisted of a piece of birch or pine 12" long, 5" wide, and $1\frac{1}{2}$ " thick. 1, Fig. 3.⁹ The tools used were the rule, pencil, gauge, straightedge, rip saw, and crosscut saw. The successive steps in the exercise were: (1) measuring with rule and pencil; (2) drawing lines with pencil and straightedge; (3) sawing on a pencil line with a rip saw; (4) sawing on an imaginary line parallel to the first line; (5) use of gauge; (6) sawing with rip saw again; (7) sawing on a pencil line with a crosscut saw; (8) sawing with crosscut saw on an imaginary line parallel to line just sawn.

The block of wood used in the second exercise was of the same size as the one used in the first exercise. 2, Fig. 3. The new tool used was the bow saw. The successive steps were: (1) drawing a compound-curved line, freehand; (2) sawing on this line with the bow saw; (3) sawing on an imaginary line which is parallel to the first line.

The stock for the third exercise consisted of a cylindrical piece of wood 42" long and $2\frac{1}{2}$ " in diameter, presumably just as it came from the forest. 3, Fig. 3. The new tool was the hatchet. This exercise consisted in hewing a square prism out of the cylindrical piece with the hatchet and sawing it into four pieces. One of these pieces was reserved for a sample of hatchet work, the others were used in subsequent exercises.

In the fourth exercise, the try-square and plane were used. 4, Fig. 3. The steps were: (1) Take one of the square pieces made in the third exercise and plane one of its sides; (2) plane the two adjacent sides so they will be square with the first; (3) plane the fourth side; (4) saw off the ends leaving the piece 10" long.

The fifth exercise was to make a hexagonal prism; the sixth a triangular prism. 5 and 6, Fig. 3. The seventh and eighth involved the use of rabbet and molding planes; the ninth was a chisel exercise; and the tenth involved boring,

⁹In dimensioning the original drawings, the metric system was used, but when the drawings were remade for this book, the metric figures were translated into the approximately corresponding English figures. The method of projection, also, was changed to correspond with American practice.

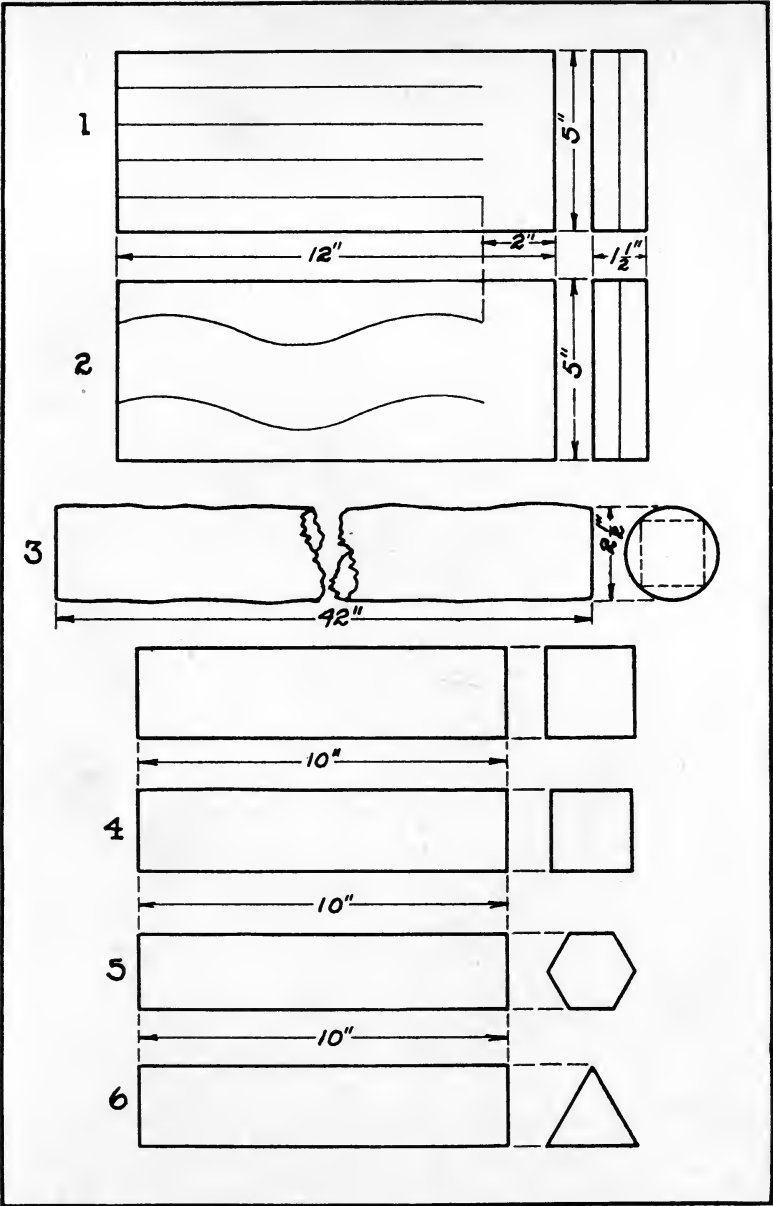

FIG. 3

chiseling, sawing, and planing. The tenth exercise completed the list of exercises in the first period of work. Fig. 4. The second period began with halved joints followed by a variety of other joints used in wood construction. Figs. 5, 6, 7, 8, 9. (6—15, 24)

The time given to this course in joinery was one year, four afternoons a week, three and a half hours each—14 hours a week.

The general character of the course in wood turning is indicated by the first seven exercises shown in Fig. 10, four of these constituting the first period of work. It is noticeable that templets were used to test the accuracy of the exercise pieces.

Figs. 11 to 15 show the first twenty-six of the forty exercises in blacksmithing. Exercises Nos. 1, 2, 3, 8, and 11 belong to the first period of the course. The fortieth is the tongs problem so familiar to American teachers of forging. In the work of this course, each student was required to accustom himself to managing the fire and the bellows. Then he would work with the sledge hammer. After these experiences, he would begin to work out the exercises of the course.

All castings and forgings in the locksmith course were given to the students in the rough condition in which they come from the foundry or the blacksmith shop. The shaping and finishing were all done with hand tools. Nos. 1, 2, 3, 4, 6, 7, 8, and 11, Figs. 16, 17, and 18, belong to the first period in which the fundamental processes are taught. Figs. 19 and 20 give exercises that follow.

6. Methods of Teaching. The method of teaching changed with each of the three succeeding periods in the course of instruction.

Before work was begun in any shop, it was the duty of the teacher in that shop to see that every bench or working place was provided with the proper set of tools. It was also the duty of the teacher to see that sufficient stock was provided for his pupils. At the beginning of the *first* lesson in woodworking, the teacher assembled the pupils around a

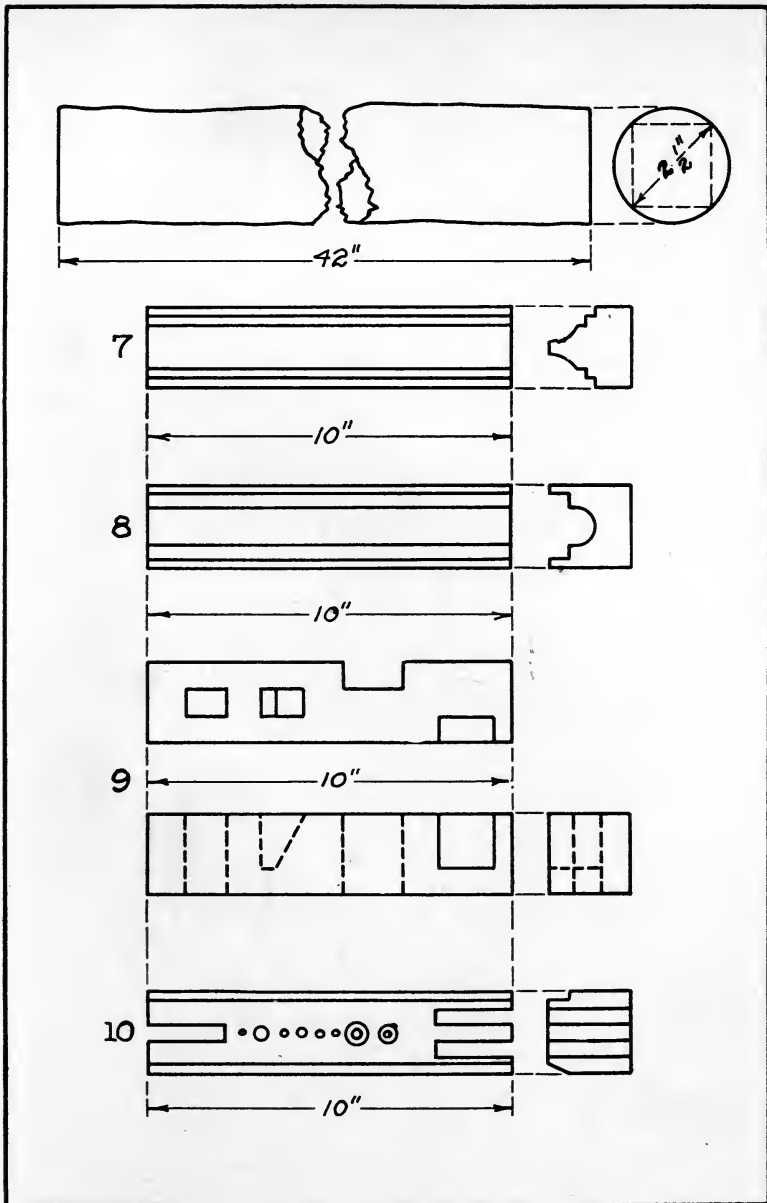

FIG. 4

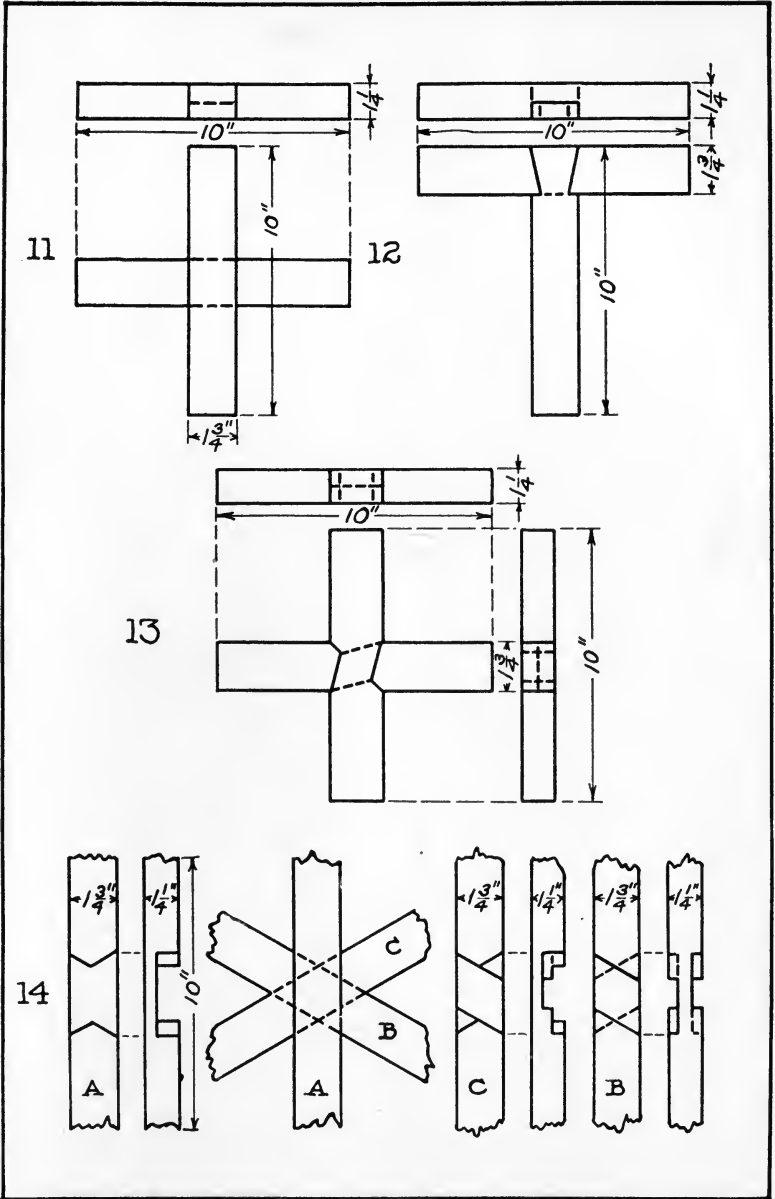

FIG. 5

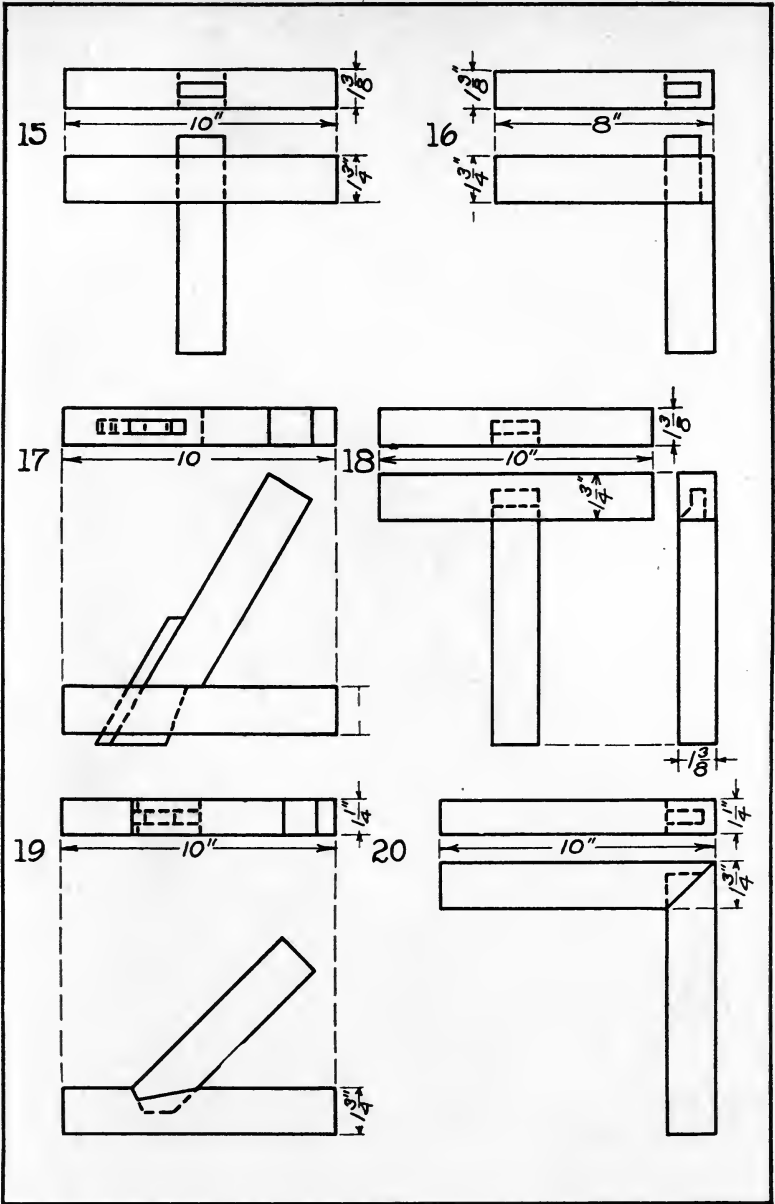

FIG. 6

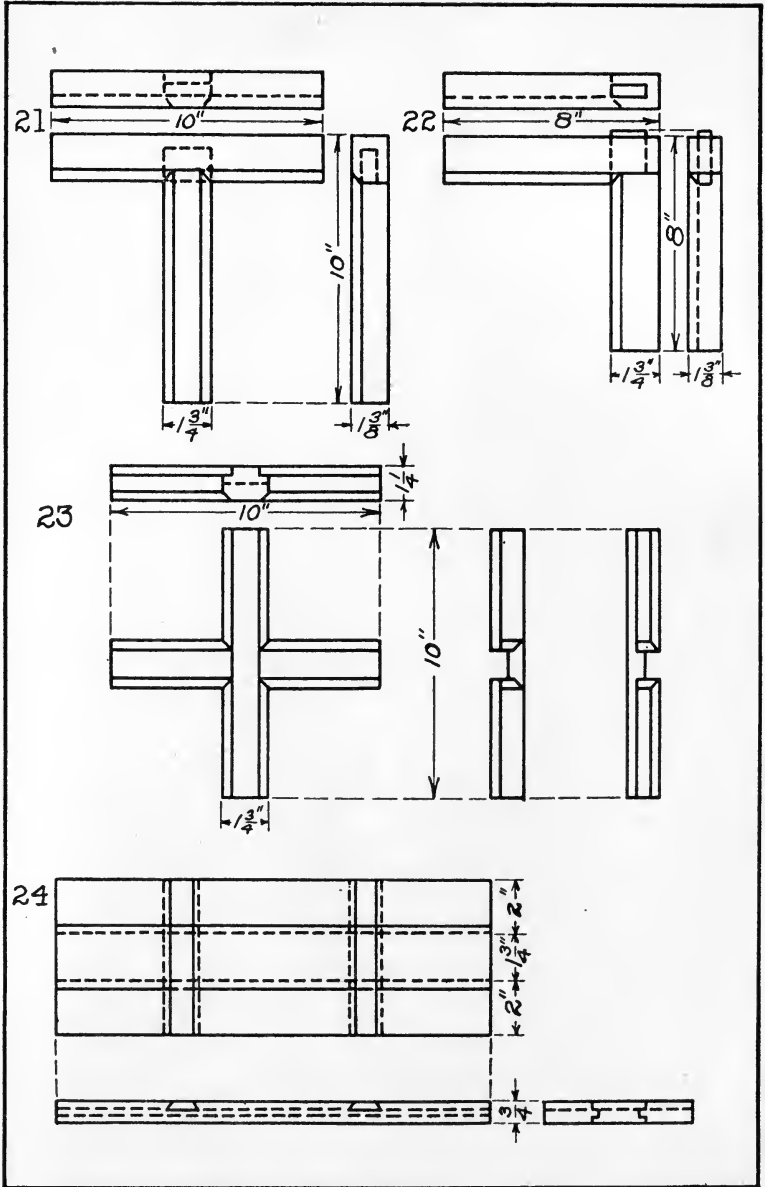

FIG. 7

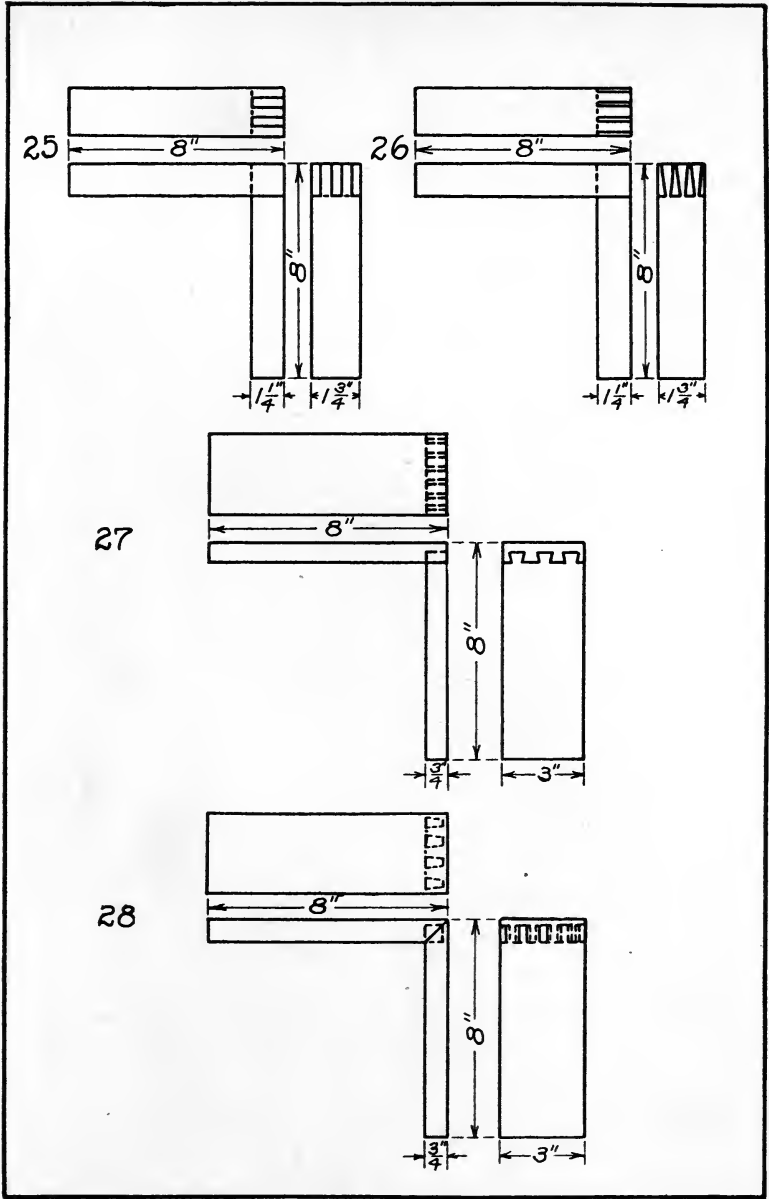

FIG. 8

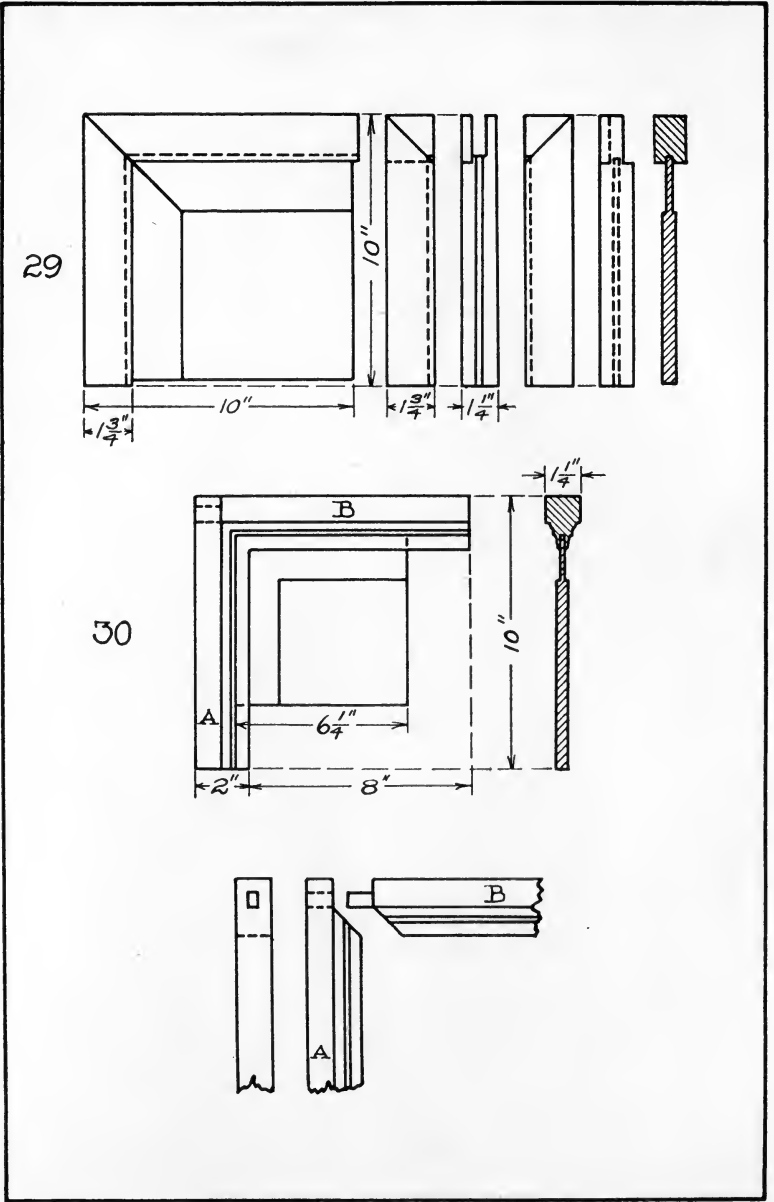

FIG. 9

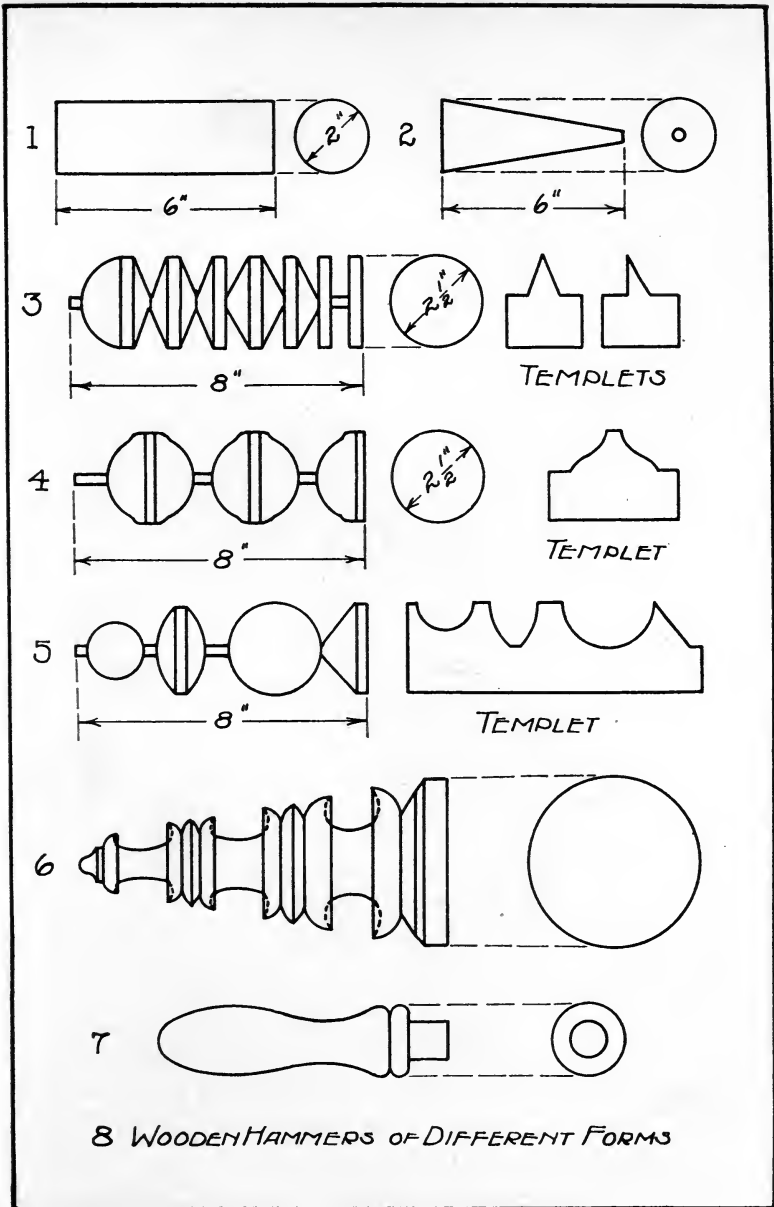

FIG. 10

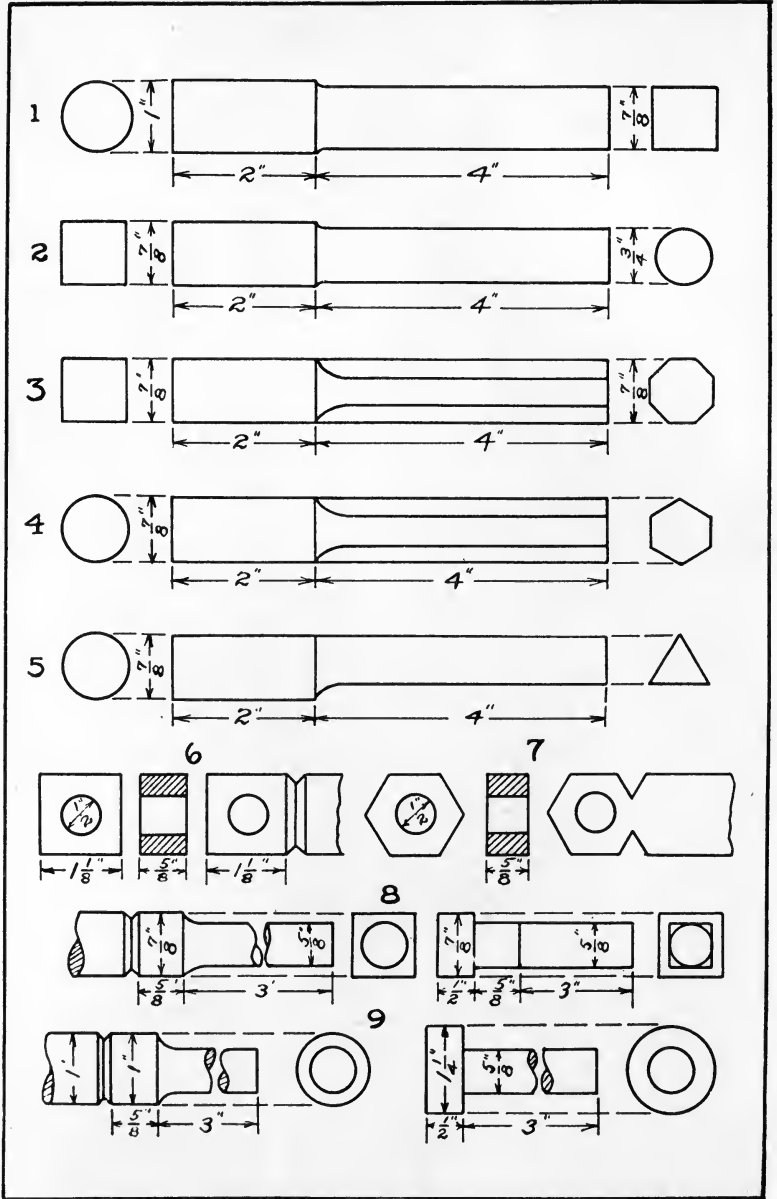

FIG. 11

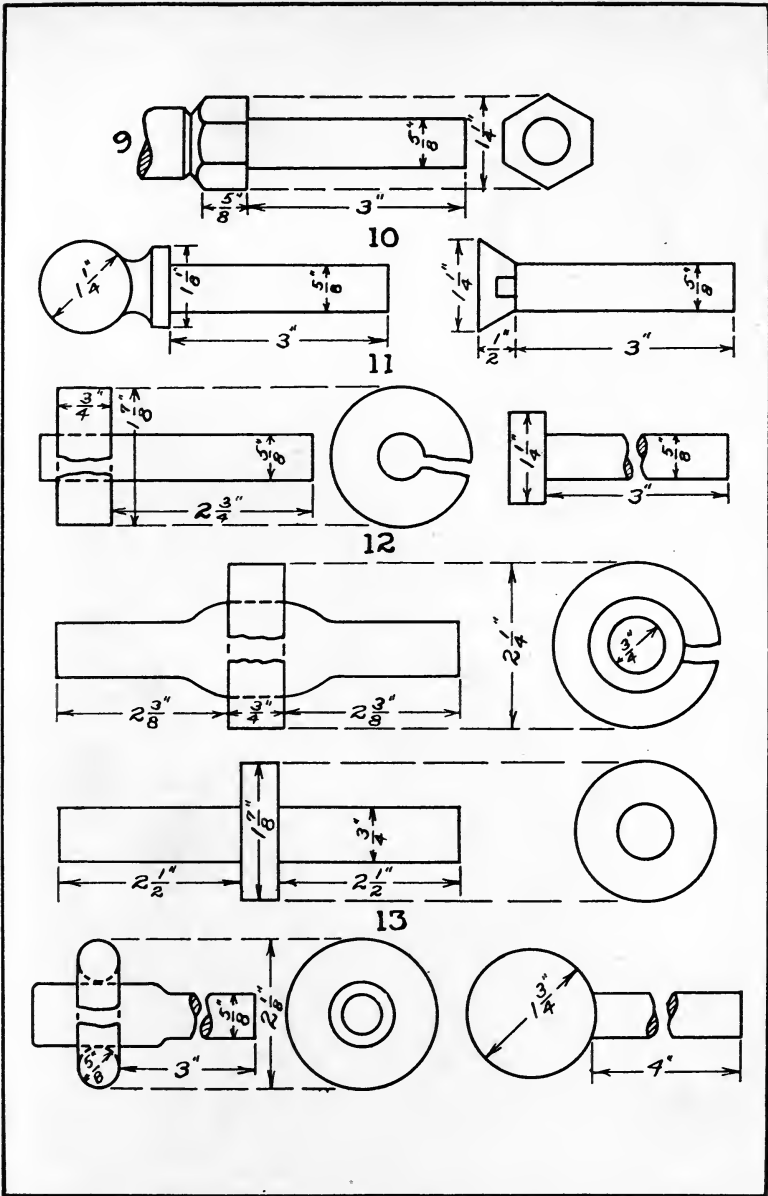

FIG. 12

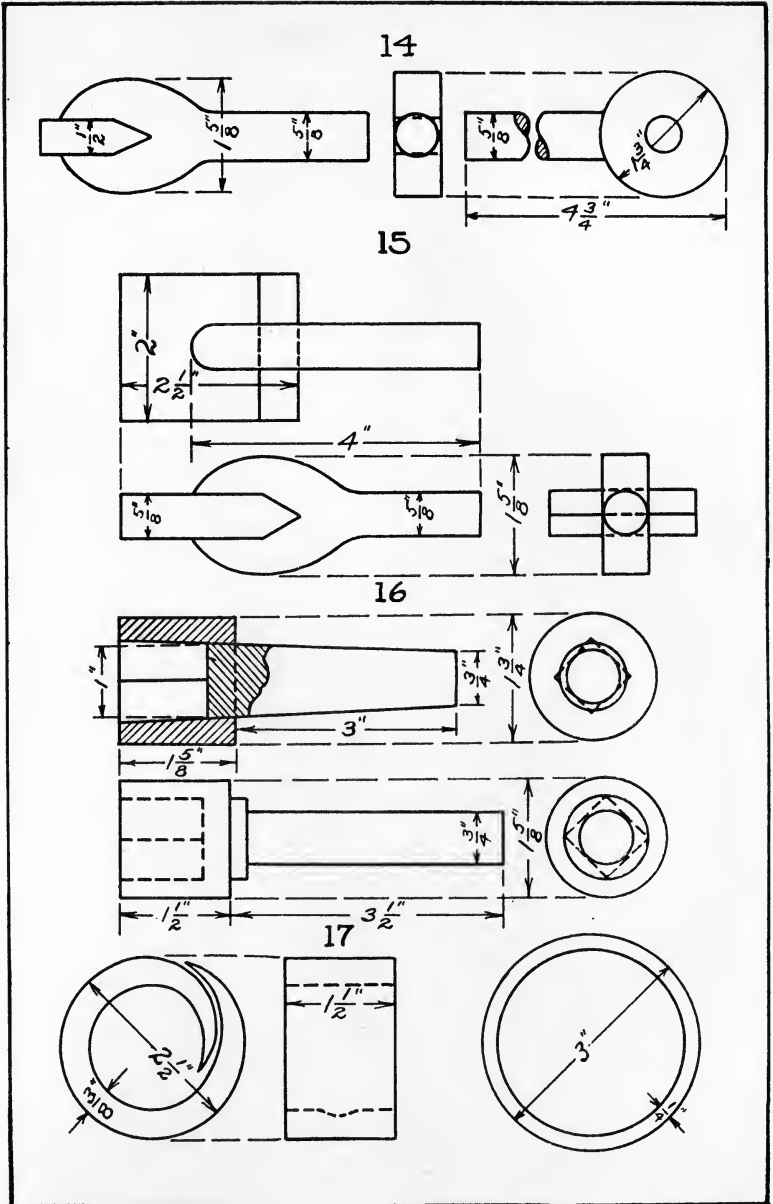

FIG. 13

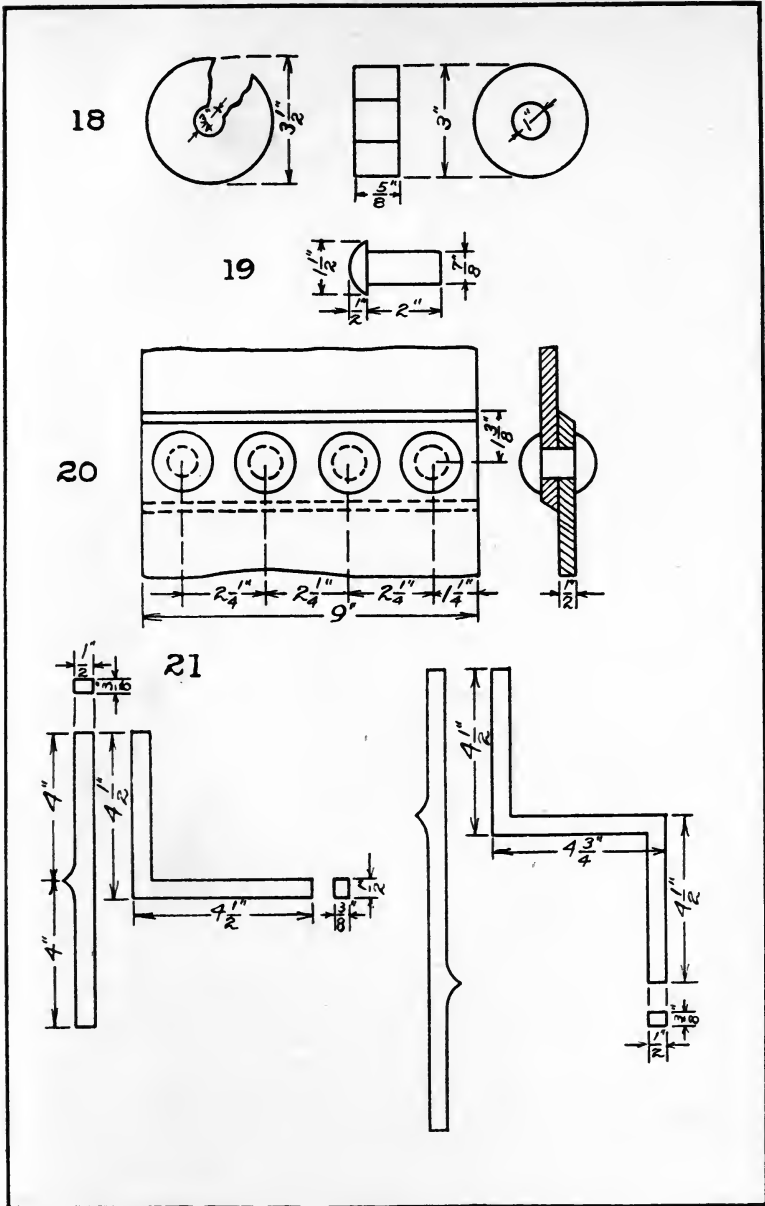

FIG. 14

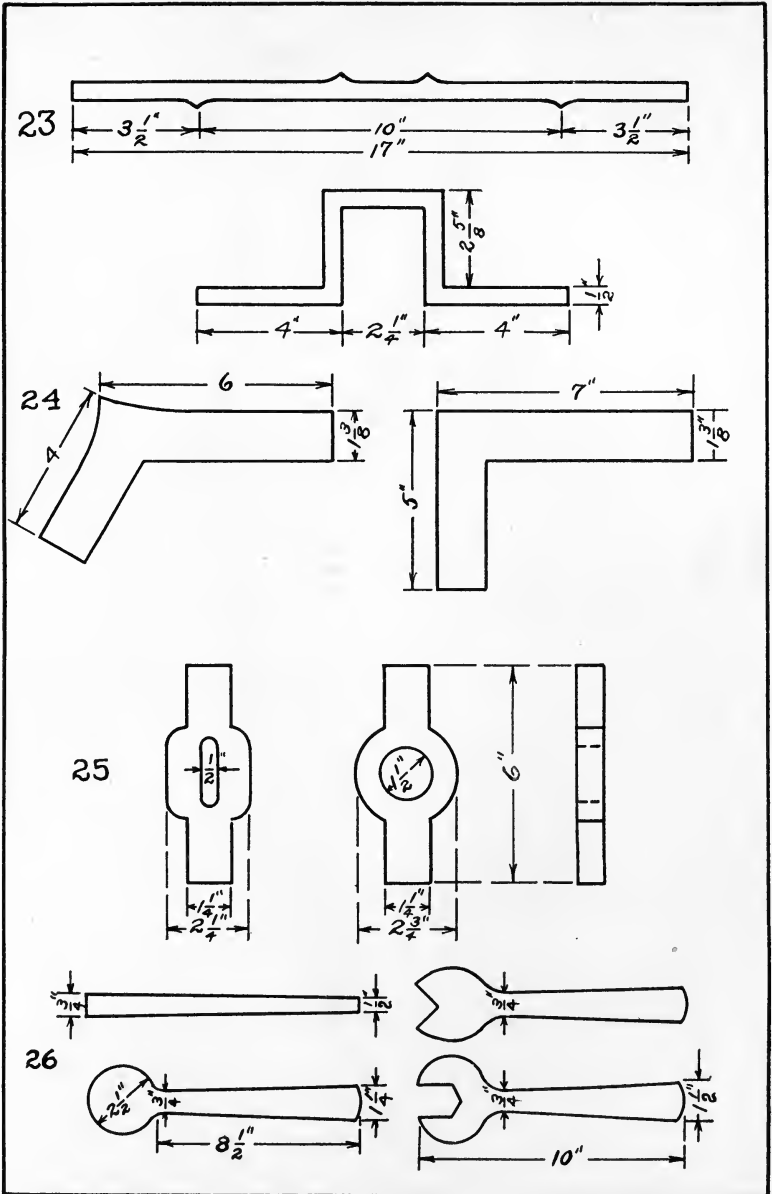

FIG. 15

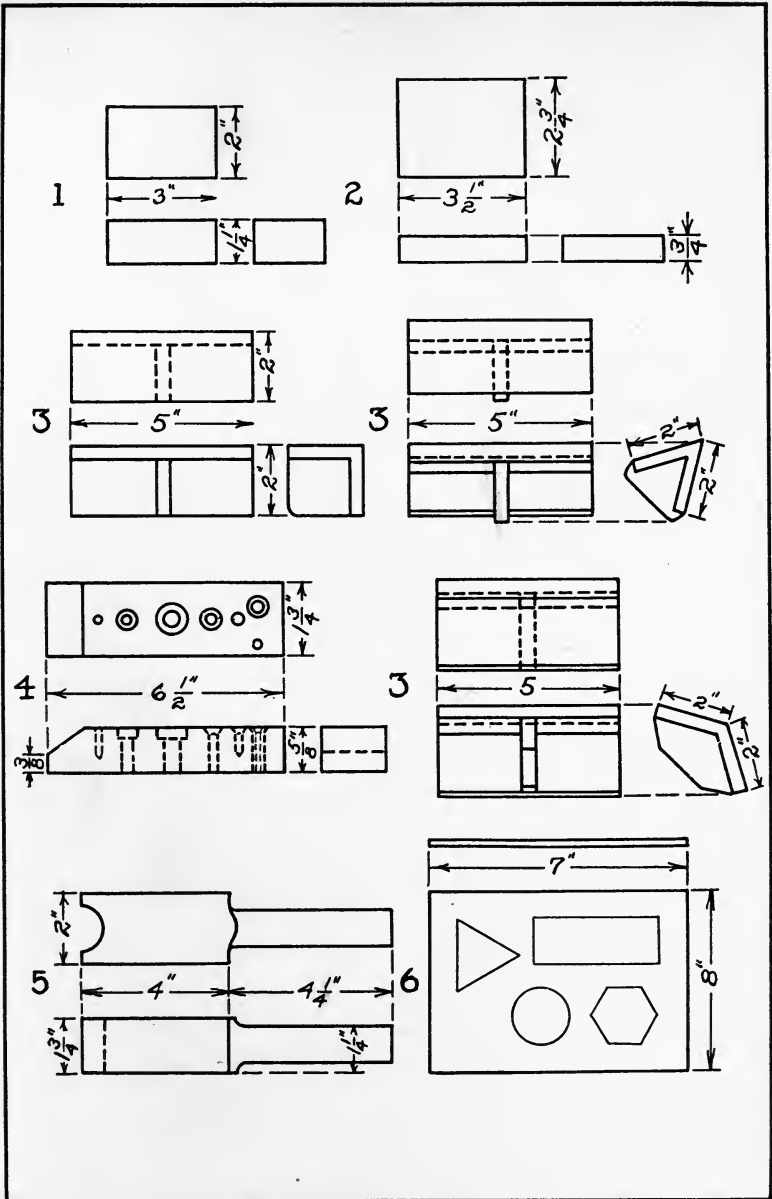

FIG. 16

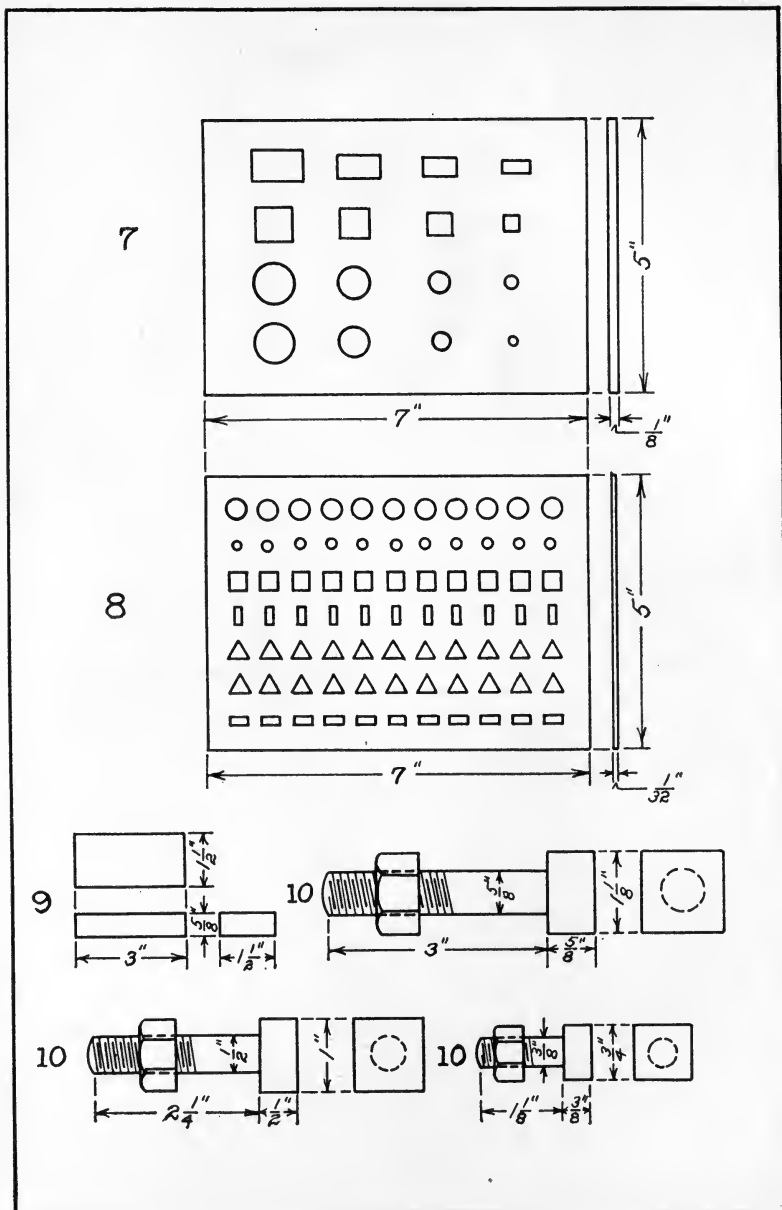

FIG. 17

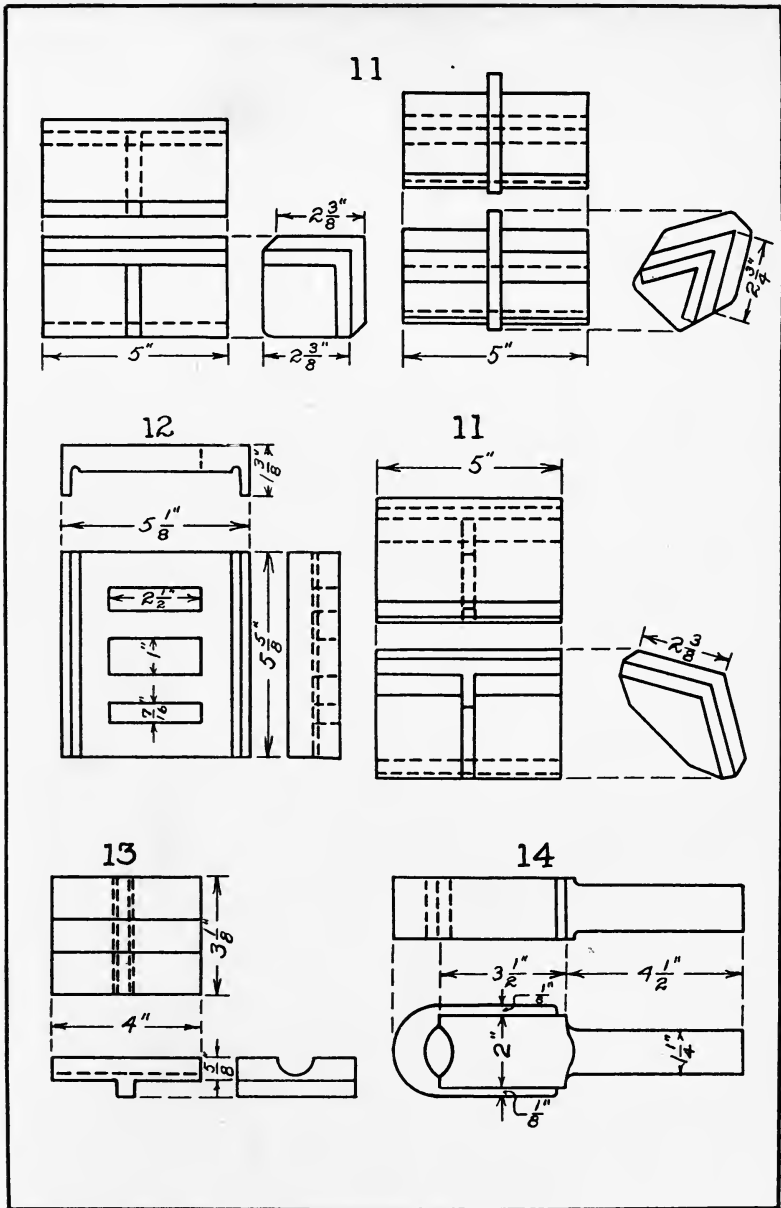

FIG. 18

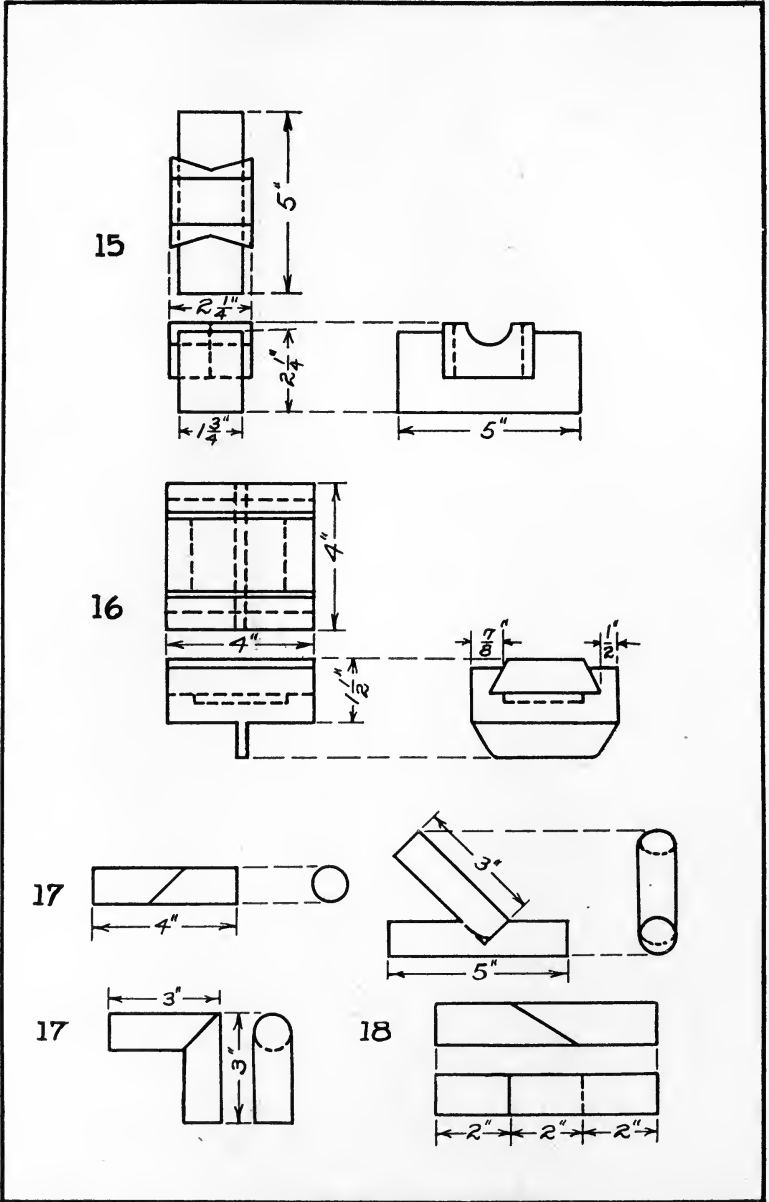

Fig. 19

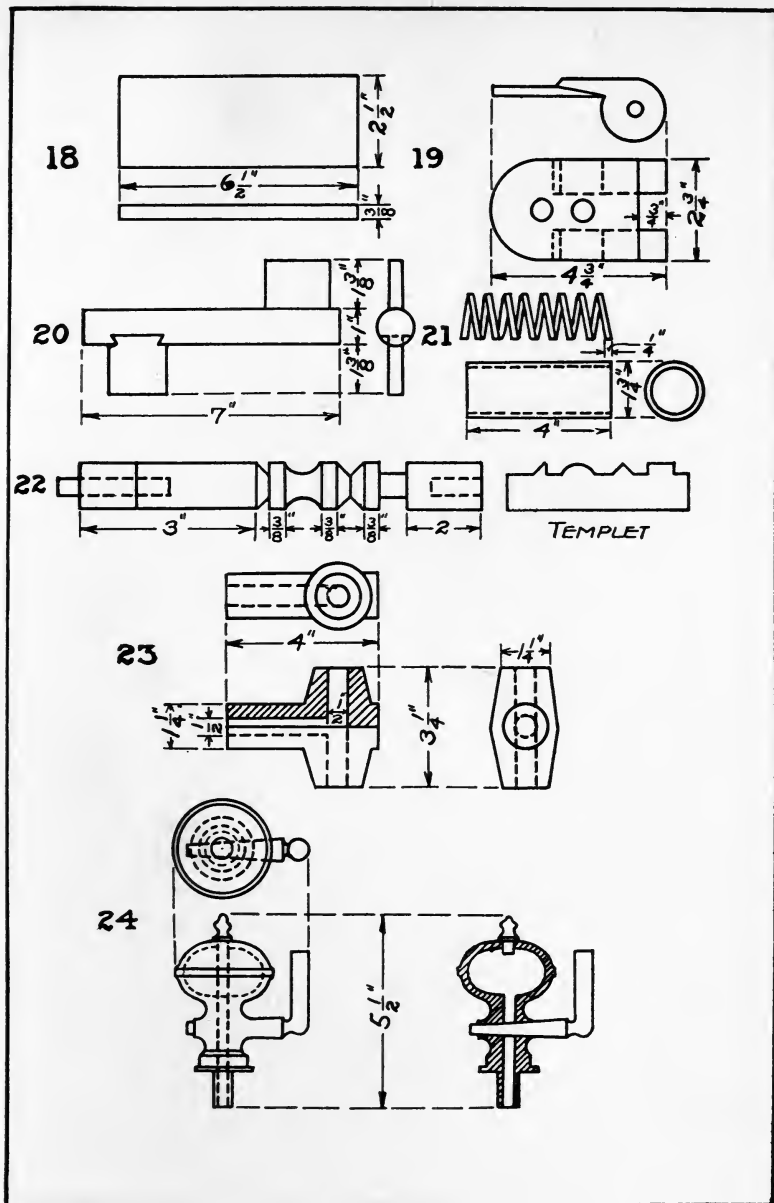

FIG. 20

workbench, upon which was placed one of the regular sets of tools. He described the bench and the tools and made the pupils acquainted with the principal qualities of the material to be used. He then turned to the tool that was to be used first and gave a more detailed description of it; he showed how it should be held and used, and illustrated its proper use by using it himself. A bench and set of tools was then assigned to each pupil in the class and he was told to proceed with the first exercise.

Each pupil was provided with a "workbook." In this he was required to record the successive steps in working each exercise. These books must be accurate, must always be clean and be kept with the tools at the bench.

Following the class instruction, the teacher went from pupil to pupil, giving individual help where it was needed. He often made his comments in a loud voice so that pupils near him might profit by his criticisms. The teacher was obliged to follow closely the work of every pupil in order to prevent the formation of bad habits. He demonstrated by doing work with his own hands as often as possible. During this time, he became acquainted with the peculiarities of each of his pupils and gained their respect, thus enabling him to exercise the necessary authority over them.

Each operation on a given piece had to be acceptable to the teacher before the pupil was allowed to proceed to the next operation. This was considered to be the only way to avoid excessive waste of material and to insure correctness in the completed piece.

In order to accustom the pupils to orderliness and care in the treatment of tools, the teacher examined each set as often as possible and noted the manner of keeping them. The drawing which the pupil received from the teacher at the beginning of the lesson was returned not later than the end of the lesson. This, also, the teacher examined to see how it had been treated. The first period demanded of the teacher the most constant attention to details.

In the *second* period of instruction the observation by the teacher of every action of the pupil might be gradually

weakened so as to develop in him independence. The teacher now guided the action of the pupil only in necessary cases, and had more time to devote to giving instruction that was designed to broaden the pupil's knowledge of the work in hand.

In the *third* period, although the work of the pupils continued to be under the constant supervision of the teacher, a special effort was made to develop independence in the solution of the problems given. In this period the teacher required of his pupils reports of progress on the work in hand and statements concerning their plans for future work. If these plans had not been properly thought out or were likely to require too much time in execution, he suggested changes. The time required to do work was an important consideration in this period.

Complex models might be given to a group of not more than four pupils, provided the definite task assigned to each was equivalent to that assigned to every other pupil working upon the same model.

In this period, the pupil was expected to organize the related information he had acquired during the two previous periods, and to supplement it with new facts. This was intended especially to refresh the memory of the pupil concerning information that had been given him by his teachers at different times during his course in shopwork and better prepare him for employment.

The teacher was required to keep an account book giving the number of hours spent by each pupil on the work assigned him. A carefully written copy of this book was made which must be shown at any time by request of the director of the school, the pedagogical conference, or the district inspector.

The system recognized that, owing to the various capacities of the learners and their different physical developments, they would diverge during the first part of the work in their rapidity of execution and would finish a given exercise not all at the same time but successively one after another. (6—11)

7. Some Results of the Russian System. In the year

1870 the Imperial Technical School of Moscow exhibited its system of teaching the mechanic arts at the Exhibition of Manufactures at St. Petersburg. The system met with so much favor that from that time on it was introduced into all the technical schools of Russia. In 1873 it was displayed at the Exposition in Vienna, and in 1876 it was very effectively shown at the Centennial Exposition in Philadelphia. A direct result of its presentation in Philadelphia was the opening of the School of Mechanic Arts in connection with the Massachusetts Institute of Technology in Boston and the adoption of the principles of the system by the St. Louis Manual Training School of Washington University. These schools gave it an impulse which spread over the United States, resulting in the movement to establish manual-training high schools, and even echoed back over the ocean to England. In 1878 Russia sent an extensive display of the results of the system to the Paris Exposition. In this exhibit were shown the work of four schools—two of college grade, the Imperial Technical School at Moscow, and The Technological Institute at St. Petersburg; and two of lower grade, the Alexander Technical School of Tcherepovetz and the School of Trades of the Czarewitz Nicholas at St. Petersburg. The United States Commissioner to the Exposition considered it the finest display of school work in the entire Exposition. (7—)

At the Columbian Exposition in Chicago in 1893, the exhibit of the Moscow school was shown in close proximity to work from many of the schools that came into being as a result of the Russian exhibit in Philadelphia.

8. An Early School of Mechanic Arts. As has been previously stated, the elementary instruction shops of the Moscow school were supplemented by large *construction shops*—in fact, a factory employing as many as a hundred workmen—in which the pupils completed their training. (Source Material I B). The new features of the Russian system, however, were (1) the instruction shop, and (2) the fact that, by pursuing a course of exercises, based on a scientific analysis of shopwork processes, a boy could become

a better mechanic in a much shorter time than if he worked in a factory on such productive work as he was able to do successfully. It was an easy and natural step, therefore, to reach the conclusion that a school could train mechanics by adopting the Della Vos instruction shops without the productive factory. This is just what took place in Russia and

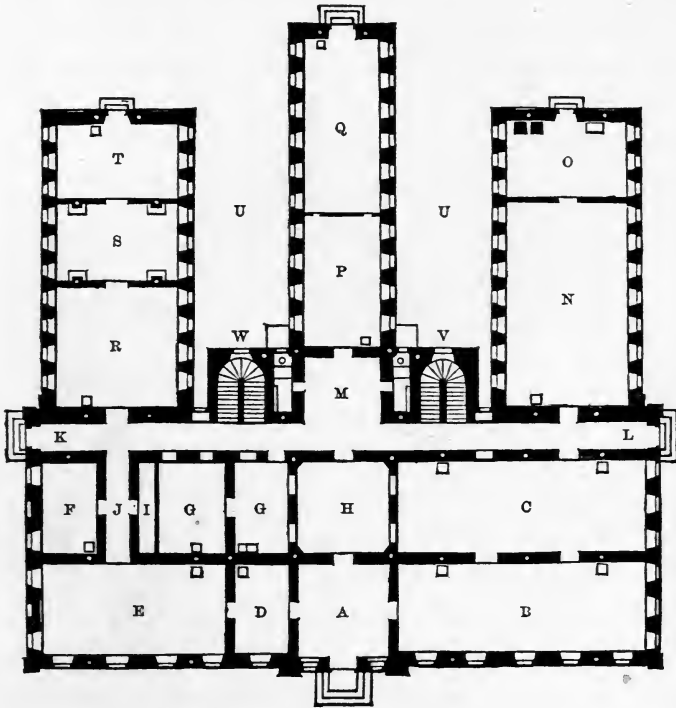

FIG. 21. FLOOR PLAN, ROYAL MECHANIC ARTS SCHOOL, KOMOTAU, BOHEMIA

elsewhere. A good illustration of such a school is that of the Royal Mechanic Arts School which opened in 1874 at Komotau, in northwestern Bohemia. Perhaps it owed its origin to the exhibit of the Moscow school in Vienna the previous year. Whether that be so or not, the director of the school, Professor Theodore Reuter, adopted the system of Della Vos after studying shop instruction methods in Europe. The simple aim of this school, as stated by Dr. John D.

Runkle, was “to educate skilled mechanics in the best and quickest way, and with such theoretical knowledge as the mechanic needs in addition to manual skill.” Figs. 21 and 22 show the type of shop building adopted at the Komotau School.

The minimum age of admission to this school was fourteen years. The course was two years in length, and the students

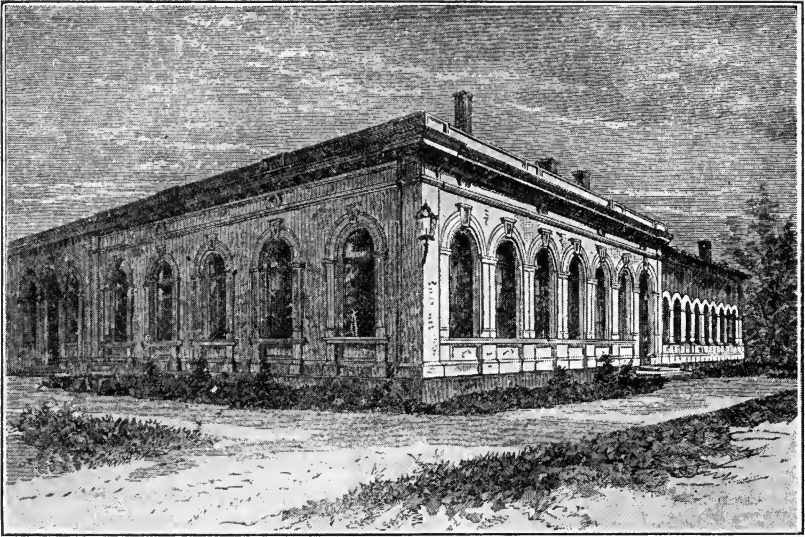

FIG. 22. ROYAL MECHANIC ARTS SCHOOL, KOMOTAU, BOHEMIA

were occupied nine hours a day—“from eight to twelve in the study and drawing rooms and from one to six in the shops.” The shopwork received primary consideration because the quality of that work was the test by which the public was to determine the value of the instruction. (3—140)

The work in this school, as given by Dr. Runkle, is as follows:

First Year's Course of Shopwork.—1. Carpentry and joinery, thirty hours per week for sixteen weeks. 2. Wood turning, thirty hours per week for twelve weeks. 3. Hand-tool work in metals, thirty hours per week for twelve weeks. In this course, the typical forms in locksmithery are used as models, preparatory to a course in application during the second year. The student changes his shopwork every four weeks.

First Year's Course of Theoretical Studies.—1. Linear drawing and the

elements of projection, ten hours per week. 2. Freehand drawing, four hours per week. 3. Round-hand writing, one hour per week, winter term. 4. Arithmetic, five hours per week in winter, and two hours in summer. 5. Geometry, three hours per week in summer. 6. Physics, one hour per week. 7. Machine theory, two hours per week. 8. Simple bookkeeping and business papers. In all of these subjects, only the simplest elements are taught in a plain and thorough way.

Second Year's Course of Shopwork.—1. Forging, thirty hours per week for eight weeks, two hundred and forty hours. 2. Foundry work, thirty hours per week for eight weeks. 3. Iron turning, thirty hours per week for twelve weeks. 4. Locksmithery, an applied course of thirty hours per week for twelve weeks.

Besides the prescribed work in this course, each industrious student can make one or more complete machines. . . . In this extra work he has only the direction, suggestions, and advice of his teachers, in order to cultivate as early as possible his independence in design and execution.

Second Year's Course of Theoretical Studies.—1. Machine drawing, ten hours per week. 2. Freehand drawing, four hours per week. 3. Arithmetic, two hours per week. 4. Stereotomy, one hour per week. 5. Applications of arithmetic and geometry to simple machine computations, three hours per week. 6. The manipulation and manufacture of metals, one hour per week. 7. Machine theory, two hours per week. 8. Bookkeeping and business papers.

In all the shops, the instruction is given through a progressive series of models, all of which each student must work; nor can he take a new one till the previous one is satisfactorily made. Any student who, through greater industry or capacity, finishes the course in advance of the class, can choose his work, with the sanction of his teacher, till the course is completed; but he cannot enter a new shop in advance of his class.

As all the materials are furnished by the school, it claims all the work. Each student has a case, with his name attached, in which his work is placed. All pieces of marked excellence are put into the collection for general and annual exhibitions in the name of the student. All the work is kept for two years, and then sold to schools and individuals for the purposes of instruction. (3—141, 144)

Later in the account of this school Dr. Runkle adds:

I was informed that the aim and end of these schools (this one and others then being established or proposed in Austria and Prussia) is to be instruction, and only when the manufacture of certain things can be taught in an applied course more successfully than ideal or purely educational models, will it be done; the principle having already been settled that these schools were in no sense to become or to be regarded as commercial manufacturing establishments. (3—145)

Finally, he quotes from the announcement of a school in Steyr, Austria, as follows:

It is now beyond question, that the required education, together with the arts belonging to the several trades, can only be gained in special schools

with workshops fitted up in the proper way. These workshops also make it possible for large numbers to fit themselves for the various technical trades, without having to travel the unpleasant path which leads through the years of apprenticeship, and at the same time to acquire the proper education. (3—145)

9. Conclusion. From the facts already stated, it is clear that the Russian system of workshop instruction in the mechanic arts did not originate, as some have supposed, as a means of teaching shopwork in a scheme of general education for students of secondary school grade. On the contrary, it grew out of a great need for a better system of giving shop instruction as part of the technical education of students of college grade. It provided a more economical and more effective school substitute for apprenticeship or at least for the early part of it, than had been devised at any previous time. It placed instruction in the mechanic arts on a pedagogical basis:

(1) It proved that the mechanic arts may be analyzed and their fundamental elements arranged in pedagogical order and taught as readily as the elements of music or drawing or mathematics or a language.

(2) It demonstrated that in teaching the mechanic arts, if the proper equipment is supplied, one teacher may successfully give instruction to a comparatively large number of young workers at one time.

(3) It revealed, however, that class instruction alone is not sufficient to avoid excessive waste of material, to insure correctness in the completed work, and satisfactory progress in the worker. The conclusion was reached that individual help must be given in addition to class instruction and that, in the earlier stages of the instruction, each operation performed by a pupil should receive the teacher's approval before the next operation is undertaken.

(4) It maintained that the teacher must be an expert craftsman in the work he is teaching and must keep up his practice at his craft, so that he will not only give correct instructions, but that the work of his own hands will be an example and an inspiration to his pupils.

Another fact that gave a certain quality to the Russian

system was that it was military in character and was operated in at least a semimilitary manner. This is evident not only in the fact that it grew up under an autocratic and highly militarized system of government, but also in the fact that the same exercise pieces were required of all students and must be taken in a prescribed order; all students were treated alike, at least, theoretically. Rules, orders, dictation, and inspection were quite at home in the system.

But the outstanding fact concerning the system remains that it was the first to use scientific principles in analyzing the mechanic arts and basing courses of instruction on these analyses.

SOURCE MATERIAL I, A

THE RUSSIAN SYSTEM OF WORKSHOP INSTRUCTION AS SHOWN AT THE
CENTENNIAL EXPOSITION IN PHILADELPHIA IN 1876

By Victor Della Vos

Excerpts from *Description of the Collections of Scientific Appliances Instituted for the Study of Mechanical Art in the Workshops of the Imperial Technical School of Moscow.*

The slight acquaintance of learned technologists with practical work in mechanical workshops entails the unfortunate consequence that, in the greater number of even very extensive works, the practical part remains in the hands of routined artisans who have received no scientific instruction, but who have attained their exceptional position by accustoming themselves during the course of many years to the most obsolete methods of practice in the mechanical art.

Seldom do the rays of science penetrate that unenlightened sphere of labor which, meanwhile, has so long demanded scientific guidance.

In the Imperial Technical School of Moscow, the course of theoretical subjects equals that of many of the polytechnical schools of Western Europe, and combines theoretical with practical education; consequently it is enabled to present real proof of the possibility and advantageousness of such a combination, since the trial of this combination has been made on an extensive scale and during a considerable length of time.

Everything that we have exhibited at the international exhibition relates exclusively to this, in our opinion, important question, and was exhibited in the desire of sharing with specialists in the work of technical education in the New World all those results which have been attained by the school in the independent investigation of this special question. . . .

Up to the present time throughout the world, the workmen at industrial works and mills are usually self-taught. Anyone who has himself been employed at a works and is familiar with the daily life of the workman in the different countries, must have perceived that the acquirement of knowledge and skill in any trade is to him a process much similar to the following: A boy of thirteen or fourteen years of age, having entered a mechanical works to learn his trade, is put during the first few years to work of an entirely unproductive kind and which has not the slightest relation to technics. He is made to carry water, sweep the workshop, crush emery, grind colors, etc. Only after the lapse of a few years and, probably, thanks to accidental circumstances, a chisel or a file is put into the hands of the youth and he is set to perform the rudest and simplest kind of work.

Then, also, if he happen to have neither father nor brother among the workmen around him, he begins learning his trade without a guiding hand, and thus commences acquiring practical knowledge and skill in his trade by observing those about him in the workshop and by his own thought and calculation and impelled by the sole desire of attaining in as short a space of time as possible the position of a paid hand in the works. There can be no doubt that, under such circumstances, the acquirement of skill by the new generation of workmen takes place in an extremely irrational manner and

without any system; the amount of knowledge obtained depends upon accident, and the time thus employed is of disproportionate length. Besides this, there is yet another inconvenience; namely, that of specializing labor to too fractional a degree. The young workman placed accidentally either to a drilling or planing machine or a self-acting lathe, endeavors to remain as long as possible at his machine, encountering, it will be understood, no objection on the part of the heads of the workshops, since such specialization of labor redounds to the advantage of the proprietors, owing to the abundance of hands.

This order of things has the deplorable result that, notwithstanding the long-continued stay of the young workmen at mechanical works, and which is sometimes prolonged through the major part of the years of their manhood, well-taught and skilled fitters are almost everywhere rarely to be met with. This will be confirmed by all those constructors who demand skilled labor for the erection of models, and of the more or less delicately constructed instruments, machines, and apparatus.

During the past few years, endeavors have been continually made to open schools for the instruction of the workmen at all works of any considerable extent. The subjects taught in these schools are freehand and linear drawing, arithmetic and many others, in the supposition that practical knowledge of works will be acquired in the works themselves.

From this it is impossible to conclude otherwise than that society, while taking measures to civilize the working classes, gives at the same time no attention whatever to the manner in which the young workmen acquire practical experience in their trades at the works; no endeavors have been made in that respect, and meanwhile, as is our subjective opinion, the question is worthy of particular attention.

The conclusion, however, forces itself upon us that this question can hardly be entered into until the young, well-taught technologist leaving polytechnical schools shall themselves possess rational experience in practical hand labor. In order that their education as specialists shall be full and ample, such knowledge is indispensable in the highest degree; though, until the present time, it has unfortunately presented a prominent deficiency in their instruction. Who will not admit that the knowledge of the manner of executing given work is a necessity to one who has to issue the project of such work?

Acting on the principle that mechanical engineers and mechanical constructors, whose future activity will be devoted preeminently to mechanical works, should have practical experience in the mechanical arts, the Imperial Technical School has employed every necessary measure for the solution of this difficulty in the best possible manner.

In 1868, the School council considered it indispensable in order to secure the systematical teaching of elementary practical work, as well as for the more convenient supervision of the pupils while practically employed, to separate entirely the school workshops from the mechanical works in which the orders from private individuals are executed, admitting pupils to the latter only when they have perfectly acquired the principles of practical labor.

By the separation alone of the school workshops from the mechanical

works, the principal aim was, however, far from being attained; it was found necessary to work out such a method of teaching the elementary principles of mechanical art as, firstly, should demand the least possible length of time for their acquirement; secondly, should increase the facility of the supervision of the gradationary employment of the pupils; thirdly, should impart to the study itself of practical work the character of a sound, systematical acquirement of knowledge; and fourthly, and lastly, as should facilitate the demonstration of the progress of every pupil at every stated time. Everybody is well aware that the successful study of any art whatsoever, freehand or linear drawing, music, singing, painting, etc., is only attainable when the first attempts at any of them are strictly subject to the laws of gradation and successiveness, when every student adheres to a definite method or school, surmounting, little by little, and by certain degrees, the difficulties to be encountered.

All those arts, which we have just named, possess a method of study which has been well worked out and defined, because, since they have long constituted a part of the education of the well-instructed classes of people, they could not but become subject to scientific analysis, could not but become the objects of investigation, with a view of defining those conditions which might render the study of them as easy and regulated as possible.

This, however, cannot relate to those arts which have been hitherto pre-eminently followed by the common and imperfectly educated class of work people, but a knowledge of which appears at the present moment to be of importance to the educated technologist.

These arts are: wood turning, carpentering, metal turning, fitting, and forging. From what we have already said, it will not be difficult to arrive at the reason of the absence of a strictly systematical method for the study of them, nor why the active working-out of such a method, without the aid of enlightened minds, may long remain deferred.

Meanwhile, the necessity of such a method, more particularly for technical educational establishments, admits not of the slightest doubt; and the filling-up of this want promises evident advantages, not only in the matter of scientific technical education, but also with regard to the practical instruction of the work people, and consequently, the perfection of mechanical hand labor itself, which, from the introduction of specially adapted machinery is, year by year, perceptibly deteriorating. (1—XIII, XX)

SOURCE MATERIAL I, B

THE SCHOOL AT MOSCOW

From Inaugural Address of President Charles O. Thompson,
Rose Polytechnic Institute, March 7, 1883

I visited the school last October (1882) and will record a few observations upon it. The first room into which I was shown by the superintendent of the shops, half the size of this chapel, was devoted to conferences with purchasers of machinery and would-be purchasers, who needed the aid of an engineer to design and draught machinery for special purposes; all the machinery thus designed is made in the school shops. This room was filled with large drawing tables, on which lay working drawings of machinery in

various stages. The second room I saw was the engine room, where a twenty-horse engine was doing its best to drive the machinery of the shops, and later I saw a duplicate of this engine, every part of which had been cast and finished in the school shops. The third rooms were the machine shops, smithy and foundry, where a hundred workmen were employed in the double duty of manufacturing and instructing the students how to manufacture; mingled with the workmen on that day were about sixty students. The fourth room was a store house in which was exhibited 60,000 roubles worth (\$30,000) of machinery and machine tools, being the result of one year's work, and just brought back from the annual exhibition of the Industries of Central Russia. An equal amount made during the previous year has been sold. The fifth rooms were a series of smaller apartments in which, for convenience, the students begin their practice. The method of teaching them is this: Each year about eighty boys are received at an average age of seventeen and a half years; the course of study is six years, of thirty-two weeks in each year; for the first, second, and third years, the boys all work in the shops fourteen hours a week, or 448 hours annually; for the fourth, fifth, and sixth years, ten and a half hours a week, or 336 hours annually, so that they work an aggregate of 1344 hours in the first three years and 1008 the second three; the rest of their time is occupied with the ordinary curriculum of a polytechnic school.

The practice for the first three years, or rather more than half of the whole, is spent in preparing for that of the second three; i.e., for the first half, they do not attempt any manufacturing, and for the second half do not do anything else. In these rooms, the boys were filing, forging, sawing, turning, etc., each as fast and well as he could, all the boys in any one room being responsible to the foreman of that room, whose duty it is to provide work for each boy and decide upon its quality. Each boy is pushed as far as possible in the time allotted to each room regardless of his mates. The work done in these rooms is mainly thrown away, though some is saved for models. (8—730)

SOURCE REFERENCES

1. Della Vos, Victor. *Description of the Collections of Scientific Appliances for the Study of Mechanical Art in the Workshops of the Imperial Technical School of Moscow*. Printed by W. Gautier, Moscow, 1876.
2. Lewis, William. *Manual Instruction in France and Switzerland*. Report of a Gilchrist student to the Court of the University of Wales. Printed at Aberystwyth about 1898.
3. Runkle, John D. *The Manual Element in Education*. Forty-fifth Annual Report of the Board of Education, Massachusetts, 1880-1881.
4. Mather, William. *Notes on Technical Education in Russia*. Second Report of the Royal Commissioners on Technical Instruction. Vol. III, London, 1884.
5. *Second Report of the Royal Commission on Technical Instruction*. Vol. I, London, 1884.
6. *Programmes for Teaching Handiworks in Technical Railway School Depending on the Ministry of the Ways of Communication in Russia*. Pamphlet prepared for the Columbian Exposition, Chicago, 1893. Printed in Russia.

7. Jewett, Eliot C. *Manual Training Schools Represented at the Exposition.* Reprint of Section of Report on Education at the Paris Exposition of 1878.
8. Clarke, Isaac Edwards. *Art and Industry, Part IV.* Industrial and Technical Training in Schools of Technology and in U. S. Land-Grant Colleges. U. S. Bureau of Education, Washington, 1898.

CHAPTER II

THE SLOYD OF SCANDINAVIA

10. **Home Sloyd.** It has been said that the modern movement for instruction in the manual arts as part of a common-school education had its origin in German pedagogy. It is equally true that the pedagogical ideas formulated in Germany were first extensively applied in the public schools of the northern countries of Europe—Finland, Sweden, Norway, and Denmark. Moreover, this movement in Scandinavia was not so much an importation as a development of earlier customs. When the new pedagogical ideas came from Germany they were as good seed falling into ground well prepared for it.

In these countries of the north where the light summer evenings are succeeded by long, dark evenings, the rural folk spend many hours within the four walls of their own cottages. And so, in early times, it came to be the custom on winter evenings for the members of the family to gather around the stone hearth, upon which a fire of logs was blazing, each one busy with some form of useful handiwork. The father and the sons, with a few simple tools, would work in wood, making ax helms, hammer handles, rakes, pins for yokes, and other devices needed for farm use; also benches, tables, forks and spoons (for the silver ones, if possessed, were used only on Sundays), and other useful household articles, often ornamenting them with simple carving. Meanwhile the mother and the daughters were spinning and weaving, knitting, and sewing the clothing for the family. As a fitting accompaniment to these fireside industries they would sing ballads and hymns or repeat favorite selections from their native sagas. (1—5)

Where no lamps were available in these rural homes, torches or candles were made of pieces of pine wood. Some

of these were as long as twenty inches. They were split into slivers at one end—in fact, far down the piece—leaving only an unsplit handle at the lower end. The boys would do this work, and if any one of them unluckily split his piece the wrong way or too far down, spoiling it, the father would turn about and slap him with his hand or with a stick to pay for his carelessness or clumsiness. Thus it was that instruction in skill, art, and patriotism was given, and discipline was maintained in the home.¹ Such handwork in Scandinavia has long been known as *sloyd* (*slöjd* in the Swedish).

As time went on, the rural folks were able to sell some of the products of the home *sloyd*. The finding of a market transformed the home *sloyd* into “domestic industries.” “It often happened that certain villages became famous for particular kinds of work, and that every boy in the neighborhood was brought up to work at that one branch of handiwork, which then acquired the character of a winter trade.” (2—vi, 369) Later, the introduction of power machinery and the factory system gradually broke down the system of domestic industries. “The introduction of machinery soon stole away the profits that had formerly been derived; greater competition and increased activity in the labor market, and more especially in the lumber trade, caused the men to quit their homes in the winter to go off with their teams to the forest in search of employment, leaving the women and girls to do all the house and farm work, with little or no time for the pursuit of *sloyd*. The result was that handiwork almost entirely disappeared from among the people, who found it cheaper to buy the articles they needed, ready-made.” (2—vi, 369) Moreover, there was a pleasing novelty about the factory-made article even though it was not as durable as the home-made one; it was in style.

Another cause for the decline of the home *sloyd* was the freedom allowed in the manufacture and sale of alcoholic drinks. Brandy making at one time took the place of the home *sloyd*. “A large part of the population became engaged

¹The facts in this paragraph and in some that follow were gained years ago in a conversation with Gustaf Larsson.

during their leisure hours, in the production, sale, and use of *bränvin*. Among the working class brandy was even regarded as currency, and taken in the payment of wages. The public health suffered from this excess; the number of crimes and public offenses increased; and as for domestic manual occupations, they ceased altogether. In 1855, a law was fortunately passed restricting the manufacture and sale of liquors." (3—II, No. 1, Part I, 35) (Source Material II A)

The result of these conditions was a breaking down of standards of both skill and character among the boys and young men. Instead of spending their evenings by the home fireside, they spent them away from home and often in public houses where liquor was obtained.

Foreseeing the serious consequences of such social and industrial conditions and realizing that the home life of former years could not be brought back again, the leaders in national policy sought to correct this by bringing back sloyd—by establishing schools in which sloyd was taught. Cronholm, the historian, tells us that before the end of the reign of Charles XIV, in 1844, sloyd schools had become numerous throughout Sweden and Norway. (4—II, 269) As early as 1846, a Swedish association was formed for the purpose of extending instruction in sloyd, and about the same time "a well-known writer, M. Hedlund, published some articles in which he eloquently advocated the importance of the subject." (3—II, No. 1, Part I, 36) (Source Material II A)

11. **Early Sloyd Schools.** But the sloyd schools of those early days were not the same as those of a later time. They were only one step removed from the home sloyd, and therefore it is only natural that the character of the work produced in them and the methods of instruction should resemble those of the home sloyd. In the first place, the pupils made what the market would purchase, without much reference to its educational value. The pupils received pay for what they made if it was sold. The schools were run on a hand-tool production basis. The demand determined what articles were to be made. In the second place, the teachers were

expected to assist the pupils as much as possible, and very often to finish a piece so that it would be acceptable to the purchaser. In the third place, the teacher was merely a foreman. Production and sale of the pieces of work made by the boys, not the education of the boys, was uppermost in his mind. The schools were on an economic basis rather than on a pedagogic; yet, in the minds of the promoters of these schools, the idea persisted that skill in sloyd and good character were developed together. This idea was perpetuated, in some degree, by the itinerant sloyder, a unique personage who went about from place to place in order to serve the homes where there were no skilled workers. This travelling sloyder would mend a chair or a table but he would not make one; that was work for a cabinetmaker. He would, however, make small articles of household use which the cabinetmaker could not make as well, such as spoons, forks, stools, and the like. He was noted for his deftness in a variety of handwork and for his wide knowledge. He was consulted on a variety of topics. If a horse was sick, his advice might be sought. He was a welcome visitor as he went among the homes where he was needed. As a proof of the high opinion held of the sloyder's knowledge and skill, it is stated that when the Bible was translated into the Swedish language, the adjective form of the word "sloyd" was used to describe the "cunning" man sent to assist King Solomon in building the temple. This workman, the Bible tells us, was "skilled to work in gold, and in silver, in brass, in iron, in stone, and in timber, in purple, in blue, and in fine linen and in crimson; also to grave any manner of graving and to find out every device which shall be put to him."²

12. **Sloyd in the Folk Schools of Finland.** During the years when the Russian system of teaching the mechanic arts was being worked out in the technical school at Moscow, the foundation was being laid for another system of teaching the manual arts under the flag of Russia. Ever since 1809, Finland had been a part of the Russian Empire, though formerly it belonged to Sweden and owed to Sweden its high

²II Chronicles: II, 7.

state of civilization. The upper classes of society spoke the Swedish language, while the Finnish peasants continued to speak their native tongue. After the peace of Paris in 1856, Alexander II of Russia, in grateful appreciation of the loyalty of the people of Finland in helping him resist the onslaught of Napoleon, visited Finland and promised the people a new and complete primary school system. (5—I, 424) In accordance with the Finnish custom, every citizen had the right, when a matter of public policy was under debate, to offer suggestions. And so it came about that a tractate of unusual merit entitled *Stray Thoughts on the Intended Primary Schools in Finland* was written by Uno Cygnaeus (1810-1888), a Lutheran preacher and teacher. Its superior quality was recognized, and Cygnaeus was selected to work out a system of folk schools for Finland. (5—I, 425)

In his youth, Cygnaeus was taken by his father to various workshops and given an opportunity to acquire considerable general manual skill. After graduation from the University of Helsingfors, he was, from 1840 to 1845, chaplain to a trading colony at Sitka, in what was then Russian America, now Alaska. While in America, he was deeply impressed with the difference between "the cultivated people he met at the Governor's table" and the natives who came to barter the produce of the chase. To these observations and his experiences in Alaska, he ascribed some of his earliest thoughts on the need for and character of popular education. During the next twelve years he was the principal of a Finnish school in St. Petersburg and at the same time in charge of the religious instruction in the other Finnish schools of that city. While thus engaged, he made himself well acquainted with the writings of Pestalozzi and Froebel. These helped him, as he said, to shape his "half-ripened fancies" into a unified practical whole. (5—I, 424) At another time he said, "I was led to the thought that we must introduce into the school not only the Froebelian gifts and the rest of the exercises in the work recommended by him, but also for the elder children such kinds of handwork as have for their

aim the education of the hand, the development of the sense of form and the aesthetic feeling, and to help young men to a general practical dexterity which shall be useful to them in every walk of life; such work as joinery, turnery, basket making, etc. But all of these kinds of work shall not be conducted like a trade but always with reference strictly to the universal educational aims." (6—VIII, 152)

After his appointment as the first director of popular education in Finland, Cygnaeus spent fifteen months, beginning in June 1858, in visiting schools and conferring with educators in Sweden, Germany, Austria, Switzerland, Holland, and Finland.

13. **Sloyd in the Normal School Established by Cygnaeus.** The law providing for the complete carrying into effect of his plans for a system of public elementary or folk schools did not pass until 1866, but in 1863, in preparation for the operation of this law, he established a normal school at Jyväskylä. This school was patterned after those in Switzerland.³ "It was a residential school conducted on Pestalozzian principles, the time of the student being divided between studies, domestic industries, and work in the garden and field." (7—II, 610)

As previously stated, Cygnaeus believed that handwork in the folk schools should lead toward future practical efficiency, yet such a school should not become a technical or trade school. The fundamental purpose of the handwork was to be an integral part of a well-rounded elementary education. And this being his view, he maintained that the handwork should be taught by the same teacher who gave instruction in other subjects and not by a special teacher. (8—xxi, 132)

The viewpoint of Cygnaeus is set forth in a letter to a friend in the year 1882, in which he points to a difference between the handwork he has inaugurated and that in Sweden. He said, "It must be undertaken neither mechanically nor artistically, but must retain its pedagogical aim continually, i.e., the development of the eye, of the sense of

³Bennett, Chas. A. *Manual and Industrial Education up to 1870*, p. 166.

form, and the provision of a general manual dexterity, and not of some particularized and insisted skill. Moreover, I maintain strongly that handwork in the elementary school, which is a *common* educational institute, where this subject enters and takes its place as legitimately as the rest, shall be undertaken by *the teacher himself*, so that it shall not be despised as an 'extra.' " (8—xxi, 134)

On these grounds handwork was made one of the fundamental subjects in the normal school established by Cygnaeus, and an instructor in handwork was appointed on the original teaching staff.

The following extract from the proposal to establish the normal school gives further information concerning the ideas of Cygnaeus in reference to handwork:

The instruction shall aim at providing the pupil with the general handiness which is of great importance to every man, especially to the manual laborer, and also with skill in some home industry (sloyd) most suitable to the general public of our land.

The handwork in the seminary, (normal school) as in the elementary school, will not be carried on mechanically; nor will it consist of unreasoning and mechanical manipulations, which ignore the mental powers and therefore neither satisfy the mind, nor establish an inclination for work, but, on the contrary, frequently inculcate disgust and dislike for the occupation insisted upon. The handcraft should take into consideration both mental and bodily capabilities, and so influence both physically and psychically.

After having gained the necessary technical skill in the manipulation of carpenter's and turner's tools in the making of common household articles and agricultural implements, such as scythe handles, rakes, sleighs, etc., the male students should endeavor to use the acquired skill in the preparation of articles whose construction demands reflection; as, for example, simple geometrical and physical instruments, set squares, compasses, pulleys, pumps, models of agricultural implements, etc.

During the first year, the male students, especially those who, before entry, were unfamiliar with the use of the axe and saw, should saw and split wood, as well as carry out lesser carpentry repairs, not only for the acquisition of general dexterity in such work, but also to teach them neither to shun nor to be ashamed of honest work of whatever kind. . . . During the third year (it was a four-year course) there comes instruction in the method, etc., of teaching handwork in the elementary school. (8—xxi, 133)

Concerning husbandry and gardening, he said:

Work on the land shall include the principles of rational agriculture, the care of pasture and gardens, forestry, hop and flax growing, rational dairying and all that that implies, the handling of milk, butter and cheese making,

horse management, bee keeping, pisciculture, etc. These labors shall have the common aim of promoting the bodily health of the students, of bringing them to a healthy relationship with country life and arousing a love of the same, and have the specific aim of giving them instruction in the administration of a small farm, so that, in the future, as elementary school teachers, they will be able to give good advice, and, with practical experience, instruct the commonality in the administration of small holdings, and to teach the children the ground work of a rational agriculture. . . . All the outdoor work shall be performed by the students . . . ; to this end the students of each class shall be divided into working sections, each with its own "foreman" . . . For the heavier field work, haymaking, harvesting, sowing, etc., the theoretical instruction in the subjects may be postponed for some days. (8—xxi, 133, 134)

In 1890, Otto Salomon, of Sweden, said that Cygnaeus was the "first to draw a sharp distinction between the sloyd school and the sloyd instruction for elementary schools. The sloyd school he regarded as a kind of trade school and the primary school he thought of as an institution having a general educational aim, it being the only real elementary school for all. He was of the opinion that the sloyd instruction which was to be given in the elementary school was not to be a special technical training but rather a general useful foundation. 'The sloyd in the primary school must be a means of formal education' was one of the chief maxims of Cygnaeus, and he tried to apply this rule in the Finnish primary schools that had developed under his direction." (9—4)

The first class was graduated from the normal school in 1867. Thus it was that Cygnaeus trained the teachers before he put his plan for folk schools into full operation. Under the law of 1866, the elementary-school period covered six years—two in the lower school and four in the higher. Handwork might be given in the lower schools but was *compulsory throughout the higher school*. It consisted of woodwork for the boys and needlework for the girls, the time being from four to six hours a week. (10—135) This was four years before any other nation had made handwork an integral part of a national scheme of elementary education. (8—xxi, 132) Concerning the handwork itself, there is no available evidence that at this early period the handwork in the schools of Finland was based on any analysis of the processes of the mechanic arts

which was at all comparable to that of the Russian system. On the contrary, there is reason to believe that the course consisted of objects common in the home life of Finland, arranged somewhat in the order of difficulty in making, but not based on any adequate analysis of the handwork processes involved until it had been influenced by the sloyd system developed in Sweden under Salomon. (9—4)

14. **Salomon and the Schools at Nääs.** In the year 1872, there were two important events in the history of sloyd in Sweden. One of these was the vote of the national Chamber of Deputies, granting an annual subsidy of 2,500 crowns to stimulate instruction in sloyd. This amount was increased later to 10,000 crowns and again to 27,600 crowns. The other important event—important because of what grew out of it—was the establishment of a sloyd school on the estate of August Abrahamson at Nääs, about eighteen miles from Gothenburg. The first of these events gave official recognition, government aid, and consequently a new impetus to the development of sloyd schools which had been gradually increasing in number for more than thirty years. The second brought together under private-school management the forces that gave birth to the “educational sloyd” which made Nääs a great center of sloyd influence.

August Abrahamson had been a successful merchant in Gothenburg. In 1868, with his wife, who had been a famous singer, he retired to Nääs, a former hunting seat of one of the kings of Sweden. Within this great estate were forests of oak and birch trees, pastures with herds of cattle, a castle on a headland overlooking a lake, and isolated villas which gave to the place an air of simple living and comfort. Abrahamson was a lover of nature and of art, but his chief interest was in trying to better the conditions of the common people. He began by having the cottages of the peasants on his estate rebuilt and by introducing an improved system of cultivation of the land. In all this he was encouraged by his wife. It was at her suggestion, in 1868, that he opened at Nääs a sloyd school. This was intended for the boys and girls on the estate. The next year, owing to the death of Mrs.

Abrahamson, a great change took place at Nääs. Mr. Abrahamson became very lonely and wrote to his nephew, Otto Salomon (1849-1907), then a student at the Technical School of Stockholm, asking him to become his companion and helper at Nääs. Young Salomon accepted the invitation and, in order to fit himself more fully for his work at Nääs, he attended the Ultuna Agricultural Institute during the years 1870 and 1871. (2—VI, 370) Salomon's mind was "early directed to the importance of sloyd instruction," and, with Abrahamson's aid, an industrial school (Arbets-Skola) was opened at Nääs in 1872. (2—VI, 370) This was intended for boys who had completed the work of the folk school. In his *Theory of Educational Sloyd*, Salomon tells us that in this school many different kinds of sloyd were taken up: "Carpentry, carving, turning, smith's work, basket making, saddlery, stone cutting, fretwork, and painting. Other subjects, such as drawing, mechanics, mathematics, and physics, were also taught." (12—145, 146) The course covered two years, 50 weeks a year, ten hours a day—seven to sloyd and three to other subjects. (8—xxii, 9) The school started with sixteen pupils.

In 1874 a similar school was started for girls. (11—V, 7,11) In this the sloyd consisted of weaving, sewing, and domestic economy. (2—VI, 370) In the same year Salomon was appointed government inspector of sloyd schools in the district of Elfsborg, near Gothenburg, and "he soon noted the necessity for the training of special sloyd teachers." To help supply this need, he opened a class for teachers at Nääs side by side with the existing schools for the children. His plan was "to turn intelligent artisans into schoolmasters." These were to be fitted to teach sloyd "either in independent sloyd schools or in such as were attached to elementary schools." (1—12) "The school day was of the same duration as for the younger pupils; mathematics, drawing, pedagogics, and sloyd were the chief subjects of study." The course extended over one year. This first class for teachers consisted of four students. (2—VI, 371)

At this time Salomon's chief purpose was "to train working

men's children the love of work, and to teach such children to use their hands as they would be obliged to do in coming years." (2—VI, 371) It should be remembered that up to this time sloyd had been on an economic basis. While it is



Fig. 23. Otto Salomon

true that schoolmasters had sometimes assisted in the instruction, the sloyd was still essentially home sloyd.

15. **Educational Sloyd.** As soon as the demand for sloyd instruction became general, its advocates began to look more and more to the folk schools for help in teaching it. They believed that in these schools sloyd instruction could be given most economically and most effectively. On the other hand, the educators maintained that sloyd should be given no place in the schools unless it could contribute to the main purpose of the schools, which was general education, not

trade education. Just how it could serve such an educational end was not yet clear to them.

In the year 1877 Otto Salomon, Fig. 23, visited Finland and there met Cygnaeus (cf. 12), founder of the folk school system of that country. From Cygnaeus he received the idea that sloyd should become an integral part of the elementary school course of instruction, and that it should be organized on a pedagogic rather than on an economic basis. Cygnaeus insisted that the sloyd teacher should be the school teacher. He had begun to carry out his plan by giving sloyd instruction to teachers in his normal school, but he had not yet fully developed his system in the folk schools. In Finland, Salomon found the inspiration he needed, but he failed to find there a satisfactory method of organizing and teaching sloyd. (8—XXII, 37)

On his return from Finland, Salomon set himself the task of making a scientific study of sloyd as a means in education and of developing what he called educational sloyd. "He also arranged for short courses of five weeks, which could be attended by the folk-school teachers of his own district (1878). These courses received more and more encouragement, until, in 1882, the artisan training courses were entirely discontinued and the teachers' courses absorbed the whole energies of the Institute. . . . The courses finally resolved themselves into four (of six weeks) yearly: the two summer courses for men and women, the spring course for women, and the winter course for men only." (8—XXII, 37) The summer courses especially attracted teachers from every progressive country in the world and made Swedish sloyd famous.

16. General Characteristics of Educational Sloyd. There are three outstanding characteristics of the educational sloyd as developed by Salomon: (1) making useful objects, (2) analysis of processes, and (3) educational method. The first was inherited from the home sloyd in its earlier manifestations, when the things made at the home fireside were such as were used in the home or on the farm, not from the home-industries period that followed, when the things made were sold and when the things to be made were determined by

the condition of the market. All the objects made in educational sloyd were to be useful in the home.

The germ idea of the second characteristic might have come from the analytical work done by Della Vos in working out the Russian system of tool instruction, though there is no available evidence that Salomon was acquainted with the Russian system. He might have been, because that system was worked out in 1868, displayed in Moscow in 1870, in Vienna in 1873, and in Philadelphia in 1876 (cf. 7)—all before Salomon worked out his educational sloyd, beginning in 1877 or 1878. It is possible, too, that he might have learned of it through Cygnaeus, though we have no proof that Cygnaeus in 1877 was acquainted with the Russian system. With a different purpose in view, but with the same kind of analysis, Salomon, like Della Vos, based his course upon a series of elementary tool exercises and elementary forms of construction. Unlike Della Vos, however, Salomon combined his exercises into useful models. Concerning this, he said, "The so-called 'Nääs Method' is grounded upon the exercises which occur in wood-sloyd, but in such a manner that, by making practically useful articles and not abstract preparatory exercises, the pupil gains his skill and experience." (13—VI, 196)

The source of the third characteristic, Salomon frankly attributes to Cygnaeus. From him came the conviction that sloyd belongs in the folk schools as an integral part of a well-rounded elementary education. The great work of Salomon was in developing a system of instruction giving due prominence to each of these three factors, but especially to the third.

In working out the system, Salomon early reached the conclusion that he ought to reduce the many kinds of sloyd that had grown up under the home-industries impulse to one essential kind, and he selected wood-sloyd, concentrating his efforts on that one form for school purposes. His reasons were: (1) that the material was easily available; (2) that many things made of wood were useful in the homes of Sweden; (3) that working in wood was cleanly; (4) that the

processes and materials were sufficiently varied to permit of the use of a variety of tools and many forms of construction, thus providing superior educational possibilities.

In his efforts to adapt sloyd to school purposes, Salomon realized that it must be so organized that teaching it would be governed by the same educational principles as had been accepted in the teaching of other subjects. The course of instruction must be arranged with reference to the increasing difficulties in the work; the unknown must be tied up to the known; and all must be suited to the capacities and interests of children in the upper grades of the folk schools. He believed that drawing should precede or accompany work in sloyd, but he was not successful in teaching the making of working drawings as part of the summer sloyd courses for teachers because they wanted all the woodworking they could get in the short term of six weeks.

In the early years of the instruction at Nääs, he sought to make a kind of gymnastic training out of the sloyd by requiring students to become ambidextrous. In an address before a convention of gymnastic teachers in 1893, he said that workbenches should be of suitable height for the worker, that the correct standing positions should be maintained while working, and added, "It is also of importance that the workers should be accustomed to use the tools with both the right and left hands, thus alternating the exertion of the muscles of the right and left sides." (14—I, No. 7, p. 3) At a later period, however, he changed his opinion and recommended that gymnastics be used as a corrective for certain cramped positions of the body which were inevitable in doing effective work with tools at a bench. Concerning training for ambidexterity, he found it extremely difficult unless pupils began very young to use both hands alike. Teachers who were not ambidextrous were not required to change their habits in this respect. (12—56)

In addition to these characteristics, Salomon emphasized the importance of trained teachers for sloyd that was to be educational. If an artisan was to give instruction he must first become an educated teacher. If a teacher were to give

the instruction he must first become skillful in the use of tools. First he tried to make sloyd teachers out of artisans; later he spent more of his effort in making sloyders out of teachers.

17. **The Aims of Educational Sloyd.** In no respect was there a greater contrast between the Russian system and the Swedish system as developed by Salomon than in the aim of the work. The Russian system was definitely devised to train skillful, intelligent mechanics. In modern terms, its purpose was strictly vocational. The Swedish, on the contrary, was for purposes of general education; it was considered valuable for every child. Moreover, the Russian system, devised by a government engineer, was put into operation like other engineering enterprises, with speed in learning and the engineering result constantly in view, and with little regard for individual capacities; it was a mass-production system of special education. The Swedish system, on the other hand, was worked out by an educator whose primary interest was the enrichment of the education of all children during the elementary-school period, recognizing individual capacities and individual speeds in learning; it was an individual-production system, not a mass-production system of general education. In this latter respect, it was an important contribution to present-day ideals and practice in elementary education.

As might be expected, with such a purpose in view, Salomon's aims were stated in pedagogical terms. In his *The Theory of Educational Sloyd*, he divided them into two groups: (a) formative aims, (b) utilitarian aims. In the first group were:

1. "*To instil a taste for, and a love of, labor in general.*" In order to bring about this result, he said that the models must be useful from the child's standpoint; the work should not involve fatiguing preparatory exercises; it must afford variety; children must be capable of doing the work themselves; it must be real work, not a pretense at it; and the objects made should become the property of the child who makes them.

2. "*To instil respect for rough, honest, bodily labor.*"

3. "*To develop independence and self-reliance.*" In the

development of self-reliance, he suggested that "the class must not be so large as to interfere with efficient individual supervision and instruction"; that "the work of each child must be independent of that of every other child, and to secure this end, the children in the class should receive *individual* attention during the progress of their work"; that "the teacher must not tell or show too much"; that "work must accord with the capacity of the child"; that children should endeavor to discover for themselves, by experiment, "the best methods of holding and manipulating the tools"; and that "the teacher should allow as much free play to the judgment of the child as possible."

4. *"To train in habits of order, exactness, cleanliness, and neatness."* To make this possible, "the work should be such that the pupil can make it with order and exactness"; "the models must be carefully graduated according to their difficulties"; and "the work must be such that the teacher can easily control it."

5. *"To train the eye and sense of form; to cultivate dexterity of hand and develop touch."* These he would bring about largely through the making of "curvilinear models—objects whose outlines are free curves."

6. *To cultivate habits of "attention, industry, perseverance, and patience."*

7. *"To promote the development of the physical powers."*
(12—30—60)

In the second group of aims he gives,

1. To directly give dexterity in the use of tools.
2. To execute exact work.

18. **Equipment for Swedish Sloyd.** The equipment used in the educational sloyd developed by Salomon was quite different from that employed by Della Vos (cf. 4) because Salomon's system was one of individual instruction and for children from ten to fifteen years of age. He considered that under usual conditions fifteen pupils constituted a class large enough for one teacher. He thought six or eight enough for a beginning teacher and that under favorable conditions an experienced teacher might be successful in teaching a class of

“fifteen, eighteen, or at most, twenty pupils.” (15—18)

Concerning the tool equipment, Salomon said, “The best plan of all is to furnish every child with a separate set of tools, so that each individual may keep them in order—keep them sharp, and return them to their proper places when done with. This plan is, of course, difficult to carry out where it is necessary to study great economy. If it cannot be done, it is important that the whole class be provided with sufficient tools, so that the children are not kept waiting

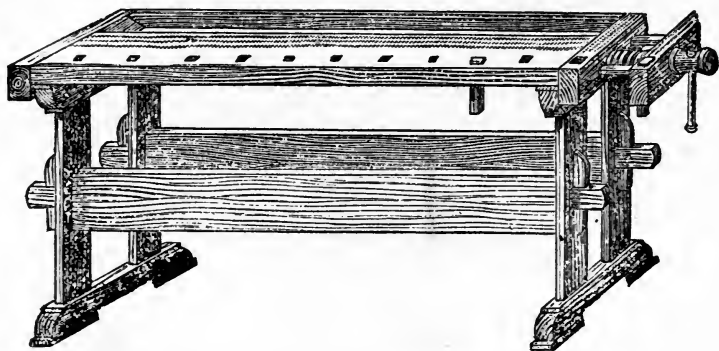

FIG. 24. SLOYD SCHOOL BENCH DESIGNED AT NÄÄS
From Salomon: *The Teacher's Handbook of Sloyd*

for each other.” (12—77) An outstanding fact concerning the educational sloyd of Salomon was that it provided for experience with a large variety of tools. The tools were the smallest sizes of standard tools used by adult workers. (15—60) The knife was the principal tool used in the early part of the course.

Concerning the place for keeping the tools, the most satisfactory plan was said to be to keep them all in cupboards where each tool had a definite place. The teacher, at a glance, could then see if any tool was missing. (12—78) This was also true when tools were arranged in racks along the wall instead of in cupboards, as was the case in many sloyd rooms.

A special school bench was designed at Nääs. It is shown in Fig. 24. Its dimensions were: length, 5 ft., width, 18",

height, 31". It will be noticed that the only vise is a tail vise. It was common to hold a piece firm between pegs while planing. Fig. 25 shows the interior of the sloyd room at Nääs. In the sloyd room or near at hand were places for storing models and for keeping unfinished work. (3—68) Fig. 26 shows the floor plan of a highly developed sloyd room in an elementary school in Stockholm.

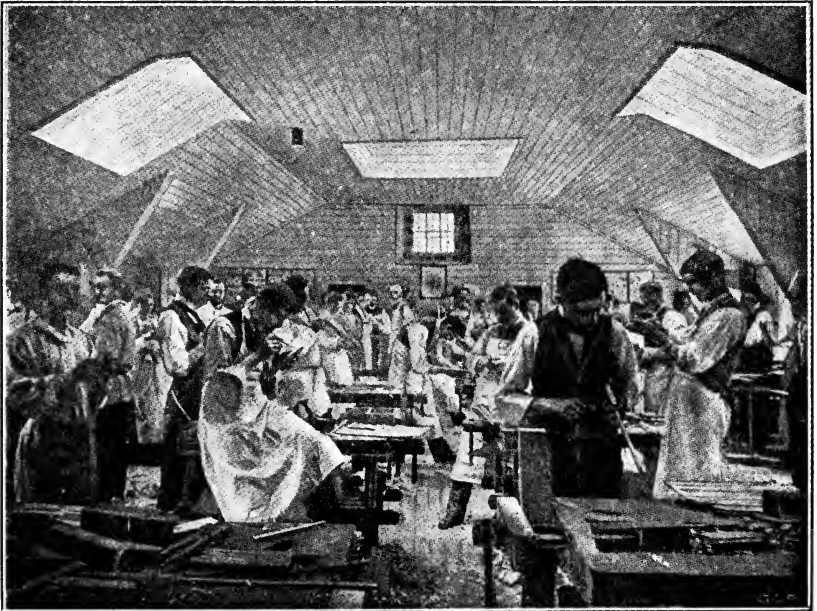

FIG. 25. SLOYD ROOM AT NÄÄS

19. **The Sloyd Models.** The course of instruction taught at Nääs beginning in 1894 is taken as typical. This was known as the "abridged fundamental series." It consisted of 68 exercises, presented to students in the form of 40 useful models. Salomon defined an exercise as "the special way of working material with a certain aim in view." (17—II, 255) Nearly every model in the course contained one or two new exercises, and these exercises were introduced in the progressive order of difficulty in execution. This order was determined by experience in teaching the work to children,

and not alone by logical analysis of tool processes. Concerning this, Salomon said, "having by experience found that one exercise is more difficult than another, it is much simpler to find the causes, than to determine the degree of difficulty by theoretical speculation." (17—II, 255)

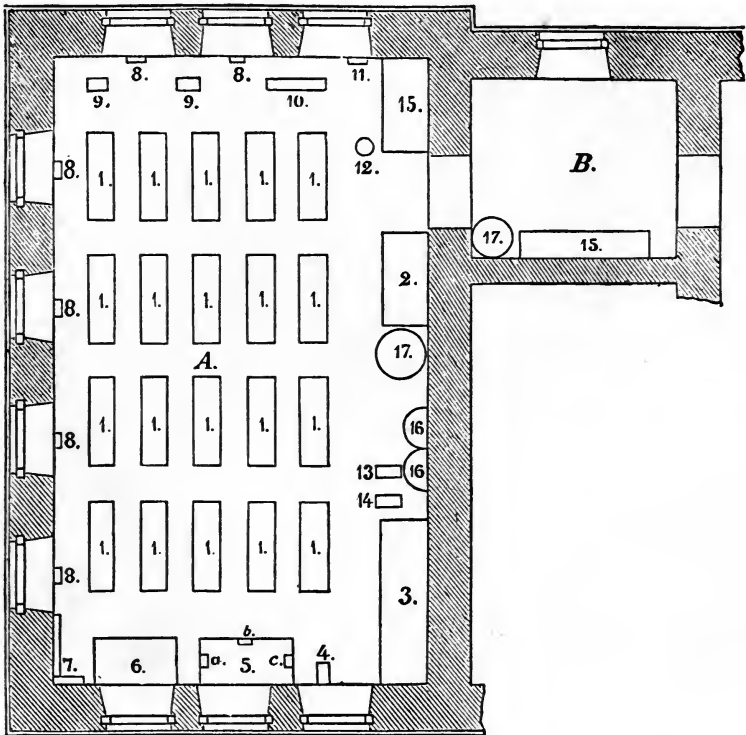

FIG. 26. FLOOR PLAN OF SLOYD ROOM, STOCKHOLM
From Salomon: *The Teacher's Handbook of Sloyd*

The list of models in the 1894 series was as follows:⁴

⁴In most respects, the drawings shown in Figs. 27 to 35 fairly represent the Swedish drawings of the models in this course. In methods of projection and dimensioning and in such details as showing the positions of nails and screws, these drawings are generally copied directly from the Swedish. The metric system of measuring is used. However, there are a few other respects in which these are different: In the Swedish drawings, all wood parts are tinted buff and all dimension and center lines are solid red; projection lines are dotted red lines.

<i>Name of model</i>	<i>Kind of Wood</i>	<i>New Exercises</i>	<i>Drawing</i>
1. Brush handle	(Birch)	Long cut, Cross cut	Fig. 27
2. Pen holder	(Alder or Birch)	Sawing off, Filing	Fig. 27
3. Parcel pin	(Birch)	Squaring, Chamfering	Fig. 27
4. Flower stick	(Pine)	Oblique cut, Convex cut	Fig. 28
5. Flowerpot stick	(Pine)	Long sawing, Narrow surface planing	Fig. 28
6. Key label	(Pine)	Broad surface planing Boring with brace and bit	Fig. 28
7. Key rack	(Alder or Pine)	Boring with bradawl, Screwing in hooks and screw eyes	Fig. 29
8. Round ruler	(Pine)	Gauging, Convex shaping with plane	Fig. 29
9. Round bat	(Pine)	Oblique planing	Fig. 29
10. Butter pat	(Birch)	Curve sawing, Concave cut	Fig. 30
11. Hammer handle	(Birch)	Oblique sawing, Scraping	Fig. 30
12. Dish stand	(Alder or Birch)	Vertical chiseling, Smoothing with plane	Fig. 30
13. Chopping board	(White or Red Pine)	End planing	Fig. 31
14. Flowerpot cross	(Pine)	Shooting, Halving (with knife)	Fig. 31
15. Coat hanger	(Pine)	Planing with circular plane, Modeling or shaping with spokeshave	Fig. 32
16. Flowerpot stand	(Pine)	Nailing, Setting nails	Fig. 32
17. Clothes rack	(Pine)	Boring and fitting plug, Beveling with plane, Gluing	
18. Half-meter measure	(Birch)	Stop-planing, Graduating	
19. Pen tray	(Birch or Alder)	Scooping out, Smoothing with spoon iron	
20. Box	(Pine)	Fastening with screws	
20. Birdhouse	(Pine)	Fastening with screws	Fig. 33
21. Bracket Shelf	(Pine)	Dovetailing	
22. Axe handle	(Oak)		Fig. 34
22. Axe handle	(Birch)	Chopping, Shaping with drawknife	Fig. 34
23. Scoop	(Birch)	Oblique chiseling, Vertical gouging	Fig. 35
24. Shoe-brush box	(Pine)	Square housing, Concave chiseling	

BRUSH HANDLE

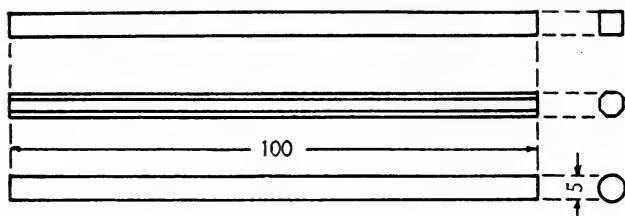

PEN HOLDER

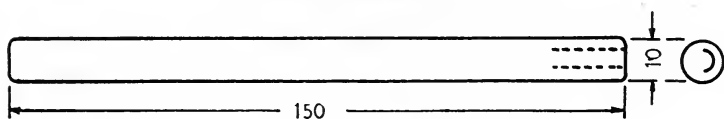

PARCEL PIN

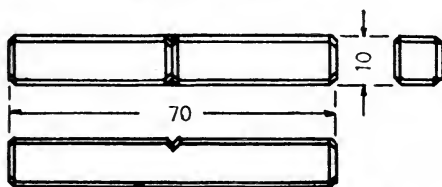

FIG. 27

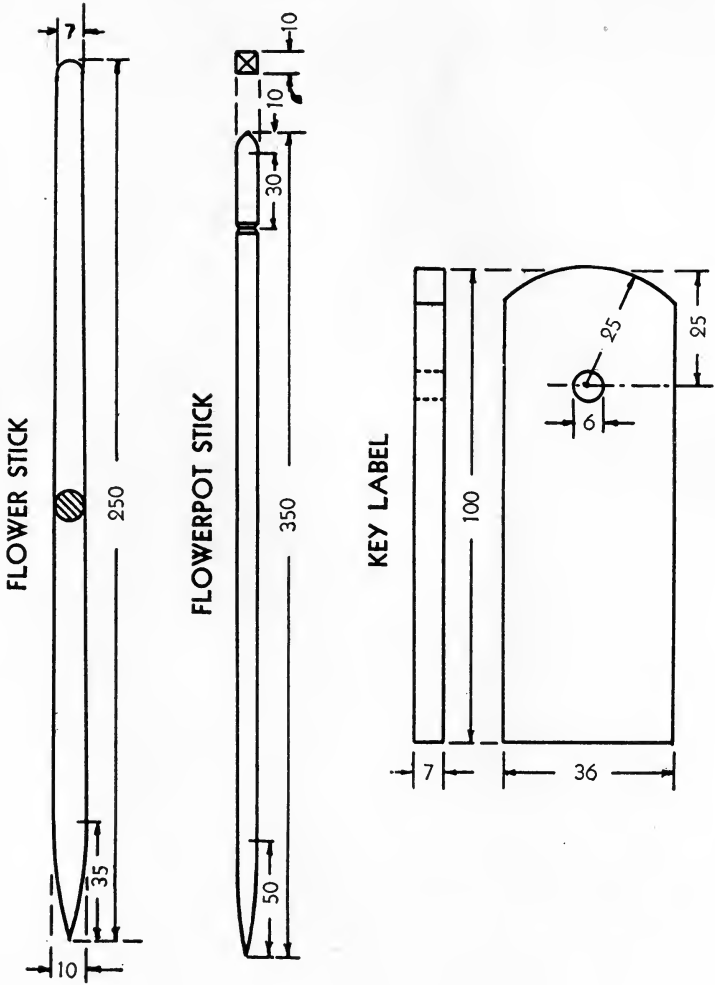

Fig. 28

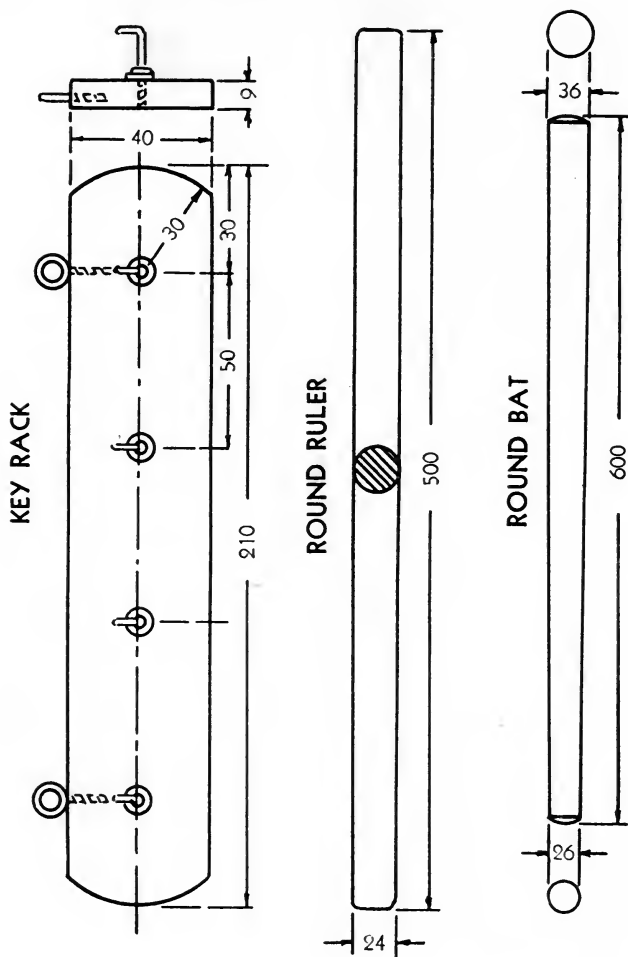
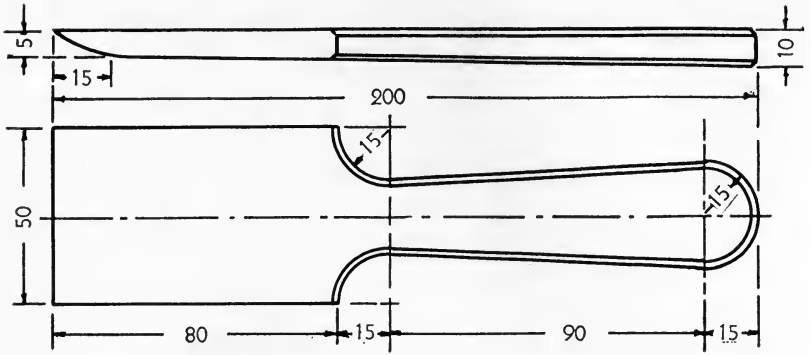
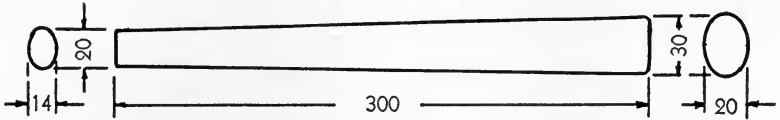

FIG. 29

BUTTER PAT



HAMMER HANDLE



DISH STAND

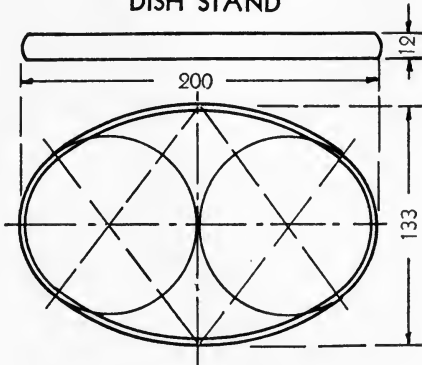
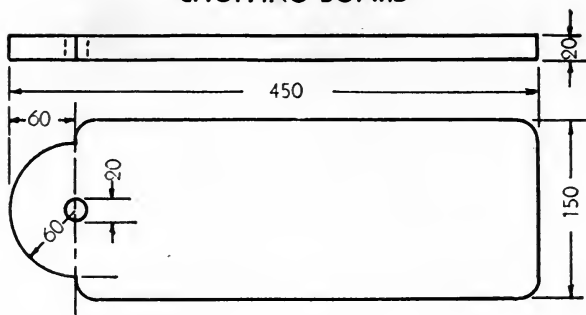

FIG. 30

CHOPPING BOARD



FLOWERPOT CROSS

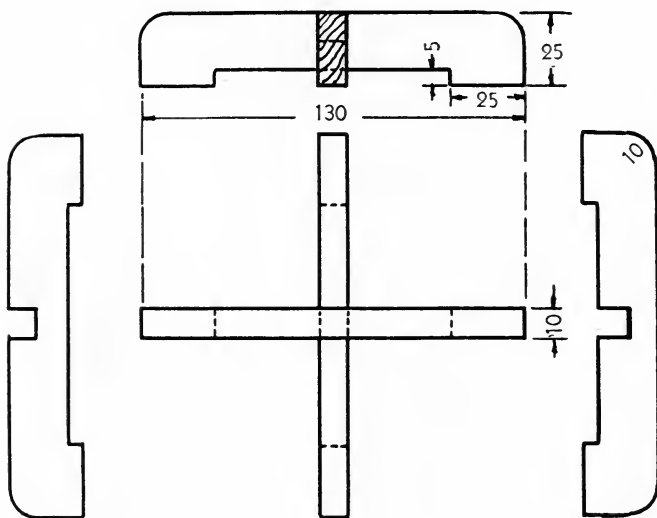

FIG. 31

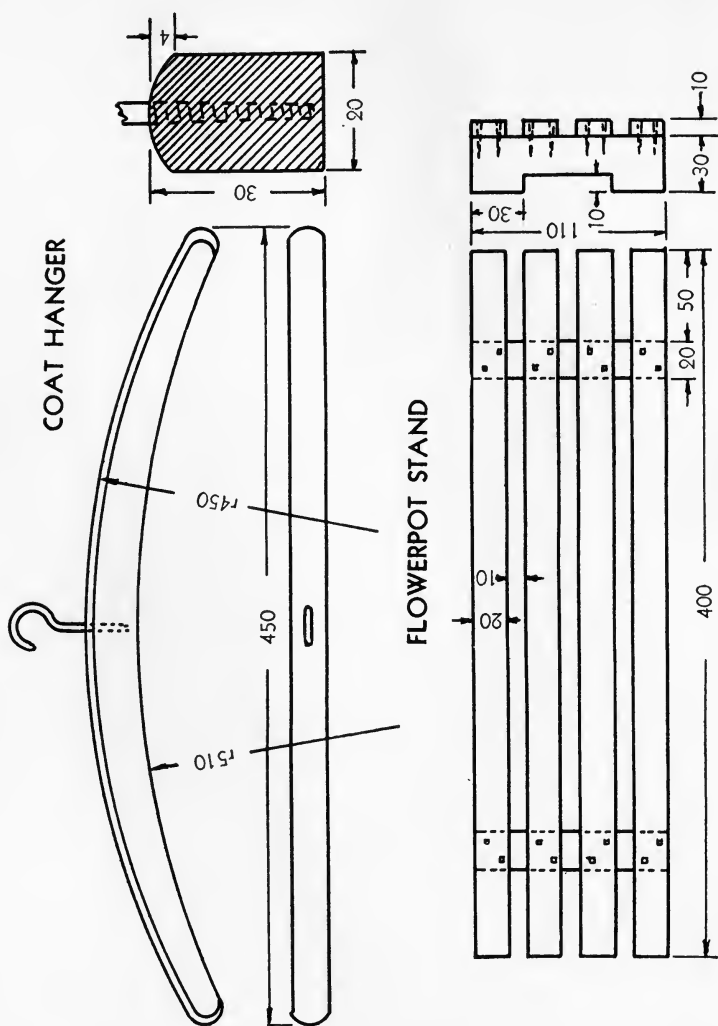

Fig. 32

BIRD HOUSE

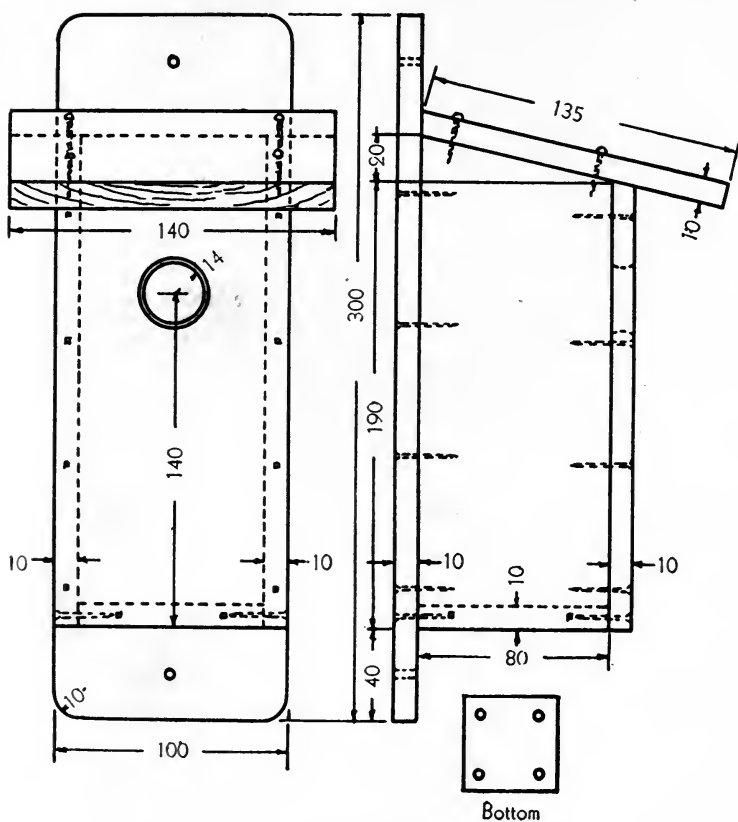

FIG. 33

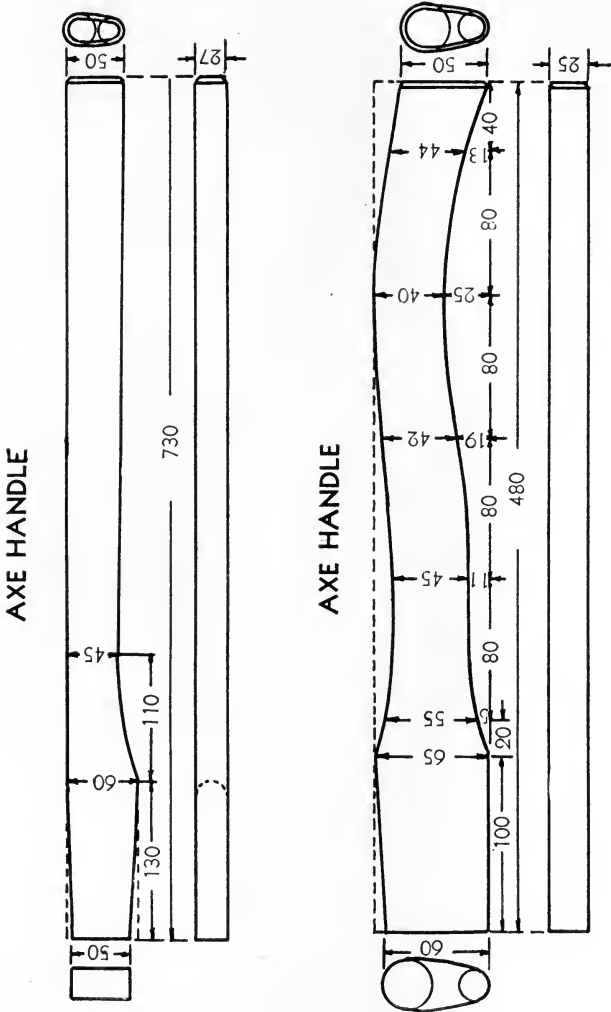

FIG. 34

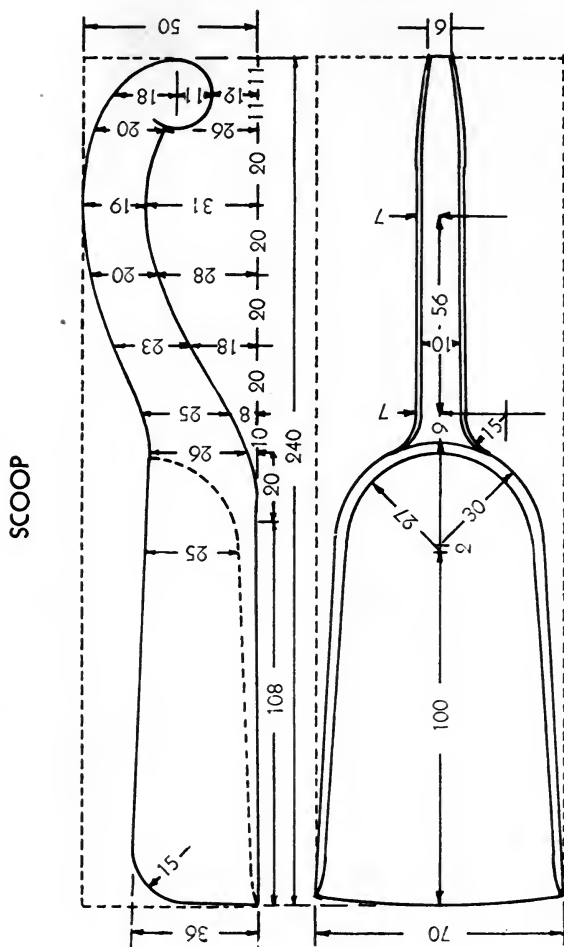

Fig. 35

<i>Name of model</i>	<i>Kind of Wood</i>	<i>New Exercises</i>	<i>Drawing</i>
25. Bootjack	(Birch and pine or alder and pine)	Single dovetailing	
26. Knife box	(Pine)	Jointing, Half-con- cealed housing	
27. Baker's shovel	(White or Red Pine)	Dovetailing, Planing across the grain	
28. Set squares	(Beech or Birch)	Fastening with wooden pegs for planing thin wood	
29. Ladle	(Birch)	No new exercise	
30. Tee square	(Beech or Birch)	Rebating	
31. Pen Box	(Birch)	Cutting small groove	
32. Stool	(Pine)	Oblique edge grooving, Sawing with compass saw	
33. Towel rack	(Pine and Birch)	Common mortise and tenon	
34. Drawing board	(Pine)	No new exercise	
35. Book stand	(Birch or Alder)	Half-lap dovetailing, Mitering	
36. Lady's workbox	(Alder or Birch)	Fitting hinges and lock	
36. Toolbox	(Pine)	Fitting hinges and lock	
37. Picture frame	(Beech, Oak, and Pine)	Half-lapping, Beveling with chisel	
38. Spice cabinet	(Pine)	Half-concealed edge grooving	
38. Bookrack	(Pine)	Half-concealed edge grooving	
39. Cabinet	(Pine)	Plowing, slotting	
40. Table	(Pine)	Up-and-down sawing, Concealed tenoning, Blocking (16—5—63)	

The study of the factors entering into the arrangement of a satisfactory series of models led Salomon to formulate rules for the planning of courses of instruction in sloyd which he presented to English-speaking teachers in a series of seven articles which appeared in *Hand and Eye*, the official organ of The Sloyd Association of Great Britain and Ireland in 1894 and 1895. In the first of this series he laid the foundation for a detailed discussion which followed. In part, he said:

In order to have some starting point for the arrangement of these models, we must, however, at first decide the aim of the instruction. This must be

done because the process of working, both as regards its full plan and details, must be directed and carried out with this aim strictly in view. A series of models intended for instruction which has as its aim the direct promotion of home or domestic sloyd must naturally appear quite different from one which has to serve as guidance for instruction with purely educational aims in view.

The educational character of the instruction having been fixed, we must, before a series of models can be rationally arranged, clearly make out in what respects and in what way the sloyd is to prove educational. It is evidently through knowledge of the goal that we learn the means by which the goal is attained.

After having more accurately decided on those sides of the children's development which through the sloyd ought to be especially attended to, one might lay down certain requirements concerning the models which are to be included in a series intended for educational sloyd. Among such demands the following may be mentioned: the exclusion of articles of luxury; the utility of the models in the homes or to the children personally; the possibility of being made at school; comparatively small consumption of material; opportunity for working in material of different hardness; choice of shapes which tend to the development of the sense of form and beauty.

Having decided these and other similar demands on the models which may be included in a properly qualified series, we must still not consider the series *arranged*. To the aforesaid general educational points of view, the purely methodical is attached as especially important. The models must not only be chosen, but also "arranged." This choice and arrangement must not be undertaken as if we only had to pick out and put together from the forms occurring in ordinary life, a series of models suited for teaching purposes. . . . It is chiefly in this methodical arrangement of the models that we see the necessity of often giving them new forms, and with a certain object as a starting point, of adding and deducting in such a manner that the making of the model will afford practice in just those exercises, no more, no less, which we wish perfected. The chief points of view in arranging a series of models are thus the *methodical*, the *practical*, and the *aesthetic*. (17—II, 148)

In a later article of the series, Salomon gave much more fully and specifically the philosophy behind his series of models:

Now wishing, as has been the case with the so-called Nääs method, to build up a method for instruction in sloyd on exercises, we must first of all decide what exercises, and how many, are to be laid down as a foundation for the methodic expression. This having been done, there is the question of arranging the selected exercises as far as possible according to the degree of difficulty required in their achievement. The exercises being looked upon as combinations of those psychical and physical states which we have termed "fundamental elements"—of which, naturally, a great number may occur—there must practically exist a large, nearly unlimited, number of exercises. . . . It is, however, evident that when these exercises are to be used for the practical purpose of being those foundation stones on which a method

for instruction in sloyd is to be built, the distinction between them must be sufficiently marked, and they must be limited as to their number. . . .

The next step, after having fixed and distinguished the exercises on which we wish to build the series of models, is to arrange them into a series of exercises. The methodical rules, that the instruction must gradually proceed from the easy to the difficult, from the simple to the complex, must be the leading principles in arranging the exercises into a definite succession. Yet, everyone who has been engaged in this work must very soon have noticed that the arranging is in itself a very difficult and complicated matter. There are so many different factors and different kinds of factors, psychical as well as physical, mental as well as mechanical, which influence the degree of difficulty between the exercises, that it is hardly possible to lay down a hard and fast rule. For instance, to saw along a given line is far more difficult than to direct the saw backwards and forwards; to bore a hole at a previously given point demands more skill from the worker than to produce a hole in the wood by only turning the brace and bit. The amount of attention and accuracy with which an exercise has to be performed very essentially affects its difficulty, a fact which must not be neglected in arranging the series of exercises. But, further, men are from birth very different both as regards mental faculties and bodily qualities. These faculties, which often run in different directions, cause those things to appear comparatively easy to one person, which to another appear very difficult, if not, indeed, almost insurmountable. As one child may have a turn for arithmetic, whilst the case is quite the reverse with another; so the achievement of the same exercise may, on account of different faculties or predispositions, afford greater difficulties to one person than to another. Whilst some people find it easier to work a curved surface than a level one, or such that are at right angles to each other, the case may, with regard to individual sloyders, be quite reversed. Thus, in deciding the mutual difficulty of the exercises, the individual differences co-operate. A comparison between exercises which are acceptable in general is rendered more difficult by the fact that people who are taught sloyd have already arrived at a certain psychical and physical development, and thus several exercises may to them seem equally easy to perform, whereby their mutual place in the series is not easily decided. It may be a matter of no importance to a person who has already acquired the art of reading whether he be asked to read the word "playing" or "play," or for the person who knows arithmetic to do a multiplication or to do a division. Different exercises of varying degrees of difficulty may be of equal difficulty to him who already possesses the predispositions for their achievement. It is evident, for instance, that it is easier to do an edge planing than a double oblique dovetailing with the same amount of accuracy; but it is hardly possible to state whether it is easier or more difficult to plane with a round plane or do an oblique gouging. It may, however, generally be accepted as a truth, that a complex exercise—that is to say, one which is made up of two or several exercises—is to be considered more difficult than each of these exercises itself. Yet we cannot from this draw the inference that all combinations, i.e. works consisting of two or several parts, would afford greater difficulty than graving with a V-tool or a knife. Shortly, in arranging the exercises according to their mutual degree of difficulty, we must rest content with an approximation that may be suf-

ficient on which to build up a series of models, largely fulfilling the claims required for a method arranged according to rational principles. May it be clear to everyone that every teacher who gives instruction in sloyd may, by careful observations, throw his stone on the pile, for (this cannot be too often repeated) good results are only gotten from that methodical manner of procedure which is derived from experience, which can not be arrived at by merely theoretical thinking. Pedagogy being the science of experience, methods which are educationally correct must be derived from the field of true observations. The observations made by teachers and pupils become colored, not only by the thing observed, but by the observer himself. Therefore, it is not likely, either in sloyd or in other subjects, that special methods can be drawn up which in all parts will be accepted by all teachers. Every teacher will always find something which does not suit either himself or his pupils.

After having thus somewhat arranged the series of exercises, the next thing will be to build up a rational series of models on these exercises. It would, from a purely methodical point of view, be sufficient if the pupils performed the exercises either one by one, or according to gradually successive combinations. From an educational and at the same time practical point of view, we may undoubtedly expect that the exercises, in a good method of sloyd, do not appear too abstract, but form part of real objects suitable for practical purposes. This, partly because instruction, psychologically correct, ought as far as possible to proceed from the concrete, being the nearest to the child, and partly because the children as well as their parents take a greater interest in an instruction of which the visible results are works of practical usefulness. . . . A leading principle in this arrangement must be, that, in the making of the model, a repetition of known exercises must occur, and, in addition, only one new exercise must be taught. If the number of models was the same as the number of exercises, only one exercise might be added to each model, but at the same time as the number of models is limited, there must needs—for the sake of “getting on”—be several new exercises taught to each model; and opinions may differ whether the apparent gain will not in the end prove a loss. It is evident that velocity and distance stand in direct relation to each other. When in both cases the time at our disposal is the same, this “getting on” must be bought at the cost of thoroughness. The more exercises that are included, the less accurately each separate one will be taught. To get on quickly, perhaps then, will appear to be the same as to get on slowly or not get on at all. To teach for life and not for school means that qualities valuable in life and not only in school are thoroughly taught. (17—III, 250)

20. Method of Teaching. An outstanding characteristic of Salomon's educational sloyd was that all instruction must be given through individual teaching. In his *The Theory of Educational Sloyd*, he devotes a chapter to the discussion of “class teaching versus individual teaching.” In this he assumes that a single fixed course is desirable for every

student and so considers the enrichment of a course for certain individual students by the introduction of supplementary models to be a waste of time and a distraction of attention from the real work of the course. He would meet the problem of individual differences in children by encouraging each child to go as rapidly as possible within the prescribed limits of the series of models, but he would not allow him to do work outside of these. He believed in a fixed series of models—a rigid course of instruction. This naturally led him to contrast class and individual teaching in their extreme forms:

Class teaching comprises the teaching of two or more children. Individual teaching comprises the teaching of one or more children. The aims of the teacher are not the same in the two cases. They differ materially. In class teaching, the teacher is apt to regard the class as a unit. It is not the development of the *individual scholar*, but of the *individual class*, that is aimed at. The minds of the scholars composing it are at various stages of intelligence; they differ also in ability. The efforts of the teacher are directed to assimilating these differences, and to securing a uniform rate of progress among all the members of the class. On the other hand, in individual teaching, the development of *each child* is the aim kept prominently in view. No effort is made to harmonize differences in ability, nor to advance the children with equal paces. The best teachers will make their methods approximate as much as possible to those employed in individual teaching.

A number of children who are being instructed and addressed *at the same time* by the teacher, may be regarded as being individually taught, *when the intellects of all those under instruction are at the same stage of progress*; and this is the limitation we must add to the definition with which we started. If, for instance, a new subject is going to be taught to a number of children simultaneously, and none of the children know anything of it, the teaching is individual teaching, because there is equality of mind, which results from uniformity of ignorance about the new subject.

But, after the first lesson has been given, this equality of mind no longer exists; for, of all the members of the class, some understood more and some less, while some retain more and others less.

The whole of the scholars, then, can no longer be regarded as an individual. . . . As the lessons proceed, the group will further subdivide, and, while they diminish in size, will increase in numbers until at last each group is reduced to a single individual, and therefore the number of so-called groups equals the number of individuals in the class, and all the children are at different stages both of knowledge and capacity. (12—60, 61)

Salomon maintained that class teaching as he defined it was “not good either in sloyd or any other subject.” “The more individual our teaching becomes,” he said, “the nearer—other things being equal—it approximates a good educational

ideal." He doubted the value of emulation; he thought it worked both ways: "The industrious boy depends on the lazy boy far more than the lazy boy depends on him." (12—65) He admitted that class teaching was more economical but not educational. He considered 15 or 16 pupils enough for one teacher and 20 the absolute maximum.

In summarizing the principles which should be given in the teaching of sloyd, Salomon gives the following list:

General

- (1) The instruction must go from easy to difficult.
- (2) The instruction must go from simple to complex.
- (3) The instruction must go from known to unknown.
- (4) The teaching must lay a good foundation.
- (5) The teacher should possess educational tact.
- (6) The teaching should be interesting in character.

Special

- (7) The instruction should be given as far as possible through the senses, especially touch and sight.
- (8) The teaching should be individual in character.
- (9) The instructor should be a teacher and not a mere craftsman. (12—10)

In presenting a new model to a student, it was outlined by the teacher or given in printed form. Three examples follow:

No. 1. Brush Handle (birch) Fig. 27

1. With the knife, cut level (a) the face, (b) one edge square with the face.
2. Mark off the breadth.
3. Cut the other edge.
4. Mark off the thickness.
5. Cut the fourth side parallel with the face.
6. Cut the wood (a) octagonal, (b) cylindrical.
7. Smooth up with sandpaper.
8. Mark off the length.
9. Cut off and make the ends square and smooth. (18—3)

No. 5. Flowerpot Stick (pine) Fig. 28

1. Saw from a board a suitable piece of wood.
 2. Plane (a) the face,
 (b) one edge.
 3. Mark off the breadth.
 4. Plane the other edge.
 5. Mark off the thickness.
 6. Plane the fourth side.
- } = Planing rules.

7. Cut the upper end square.
8. Mark off the necessary measurements.
9. Shape the upper point.
10. Cut the notch.
11. Mark the length and cut off.
12. Shape the lower point.
13. Rub off the sharp edges. (18—4)

No. 23. Scoop (birch) Fig. 35

1. Plane (a) the lower side, (b) one edge.
2. Mark off the breadth and plane the other edge.
3. Draw the upper profile on the edges.
4. Shape the upper face square with the edges.
5. Draw the outline of the scoop.
6. Shape the edges square with the lower side.
7. Scoop out.
8. Draw the lower profile of the scoop.
9. Complete the shaping. (18—11)

It will therefore be seen that, in methods of teaching, the Swedish educational sloyd was in sharp contrast with the methods of the Russian system of tool instruction. It was also quite unlike the Finnish method, which came to be one of class instruction, but with a device of its own for allowing for different degrees of skill. This was done by permitting each model in the graded course to be constructed in several different ways: "A stool may be made by different children in a class at the same time, one constructing it as a doll's model, another in a simplified, small size suitable for a child, another still, full size, yet all involving the same manipulation for which the model was chosen." The Finnish system also makes use of supplementary models for rapid pupils. (8—XXII, 37)

21. The Far-reaching Influence of Salomon. Educational sloyd came into being at just the right time to have a very wide influence. It had an immediate effect on some of the smaller schools near at hand and as early as 1882 a director of sloyd was appointed for the city of Stockholm, who gave the sloyd work in the public schools of that city a new impulse by discarding the old economic system of making a great variety of articles for sale, and adopting the principles and

methods of the Nääs system. He reduced the kinds of sloyd work to those suitable for educational purposes, and employed teachers from Nääs or sent his artisan teachers to Nääs to be trained. In a few years, Stockholm had an excellent system of cardboard work—this from German sources, however—for the middle grades, followed by woodworking and, then, in the last year of elementary school, by metalworking.

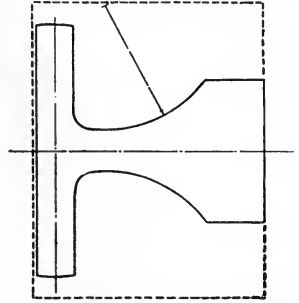
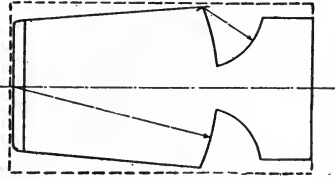
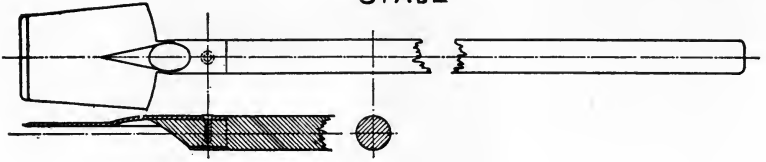

FIG. 36. METAL SLOYD ROOM, STOCKHOLM

The character of the metal sloyd is suggested in Figs. 36, 37, 38, and 39. (19—Plates)

The influence of Nääs, however, was not confined to Sweden or Scandinavian countries; it was world-wide. Nääs became the Mecca for teachers from all progressive countries who wished to get the latest and best training in educational handwork. The instruction at Nääs was free and was given in more than one language. The beautiful, natural scenery, the hospitality of the place, the inspiration of meeting teachers from different nations and discussing common problems, and especially the genial personality of Otto Salomon, acted as a magnet to draw teachers from distant lands for summer courses.

SPADE



RAKE

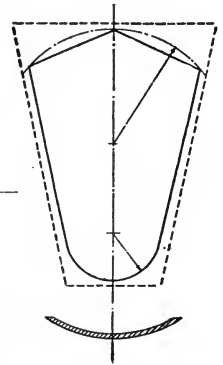
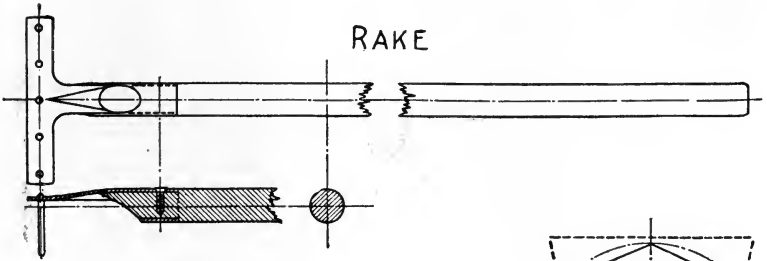

TROWEL

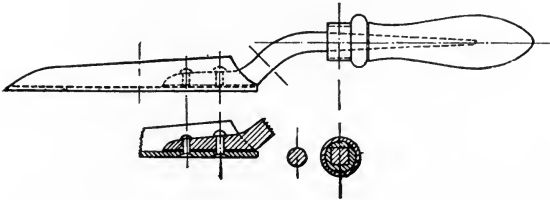
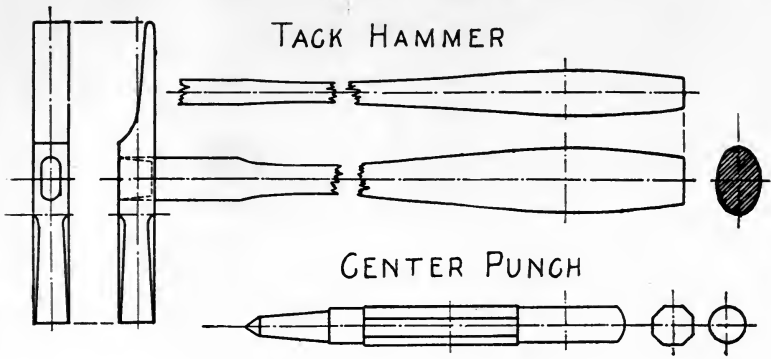
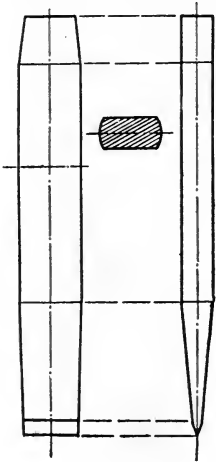

FIG. 37



COLD CHISEL



HAND VISE

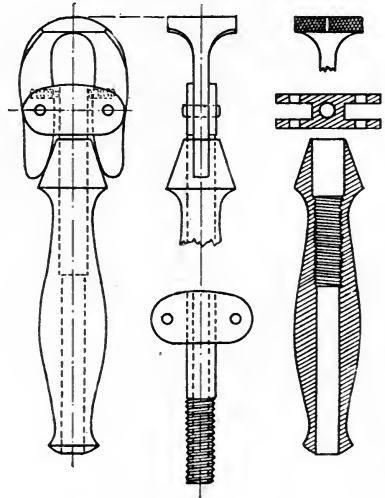

PANCAKE TURNER

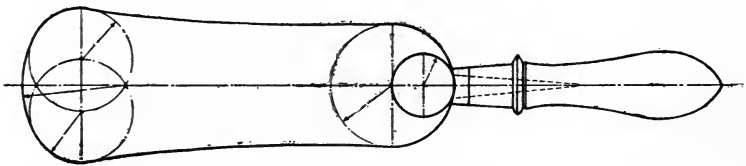

FIG. 38

COOKY CUTTER

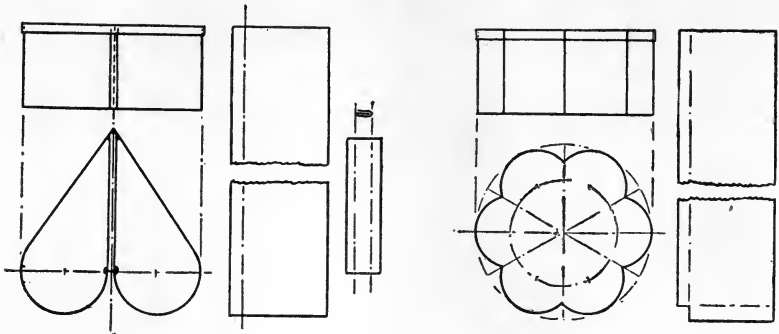

FIG. 39

During the years from 1875 to 1917, the numbers of students who came from the different countries were as follows:

Sweden,	4,740	Bulgaria,	16	Portugal,	3
England,	529	Poland,	15	Argentine,	3
Scotland,	229	Siam,	10	Uruguay,	2
United		Belgium,	9	Brazil,	2
States,	138	France,	8	Japan,	2
Norway,	127	Ireland,	8	Canada,	2
Holland,	106	India,	7	Montenegro,	1
Denmark,	97	Switzer-		Spain,	1
Finland,	97	land,	6	Serbia,	1
Austria,	67	Iceland,	5	Philippines,	1
Germany,	65	Greece,	5	Abyssinia,	1
Russia,	56	Egypt,	5	Chile,	1
Hungary,	33	South		Australia,	1
Roumania,	18	Africa,	5	Total	6,441
Italy,	17	Cuba,	5		

(20—XXII, 153)

22. Primary Sloyd. After Salomon had demonstrated the superior educational value of his system of educational sloyd for children eleven years of age and older, Eva Rodhe, the head of a school in Gothenburg, sought to supply a type of sloyd appropriate for the children of the primary grades. She wished to bridge what she considered an unfortunate

gap between the handwork of Froebel's kindergarten and that of Salomon's sloyd. She was convinced that "a little child requires as much exercise as a big one, that the effects of sitting still in the classroom are as bad for the one as for the other," and that, relatively speaking, the heads of the primary

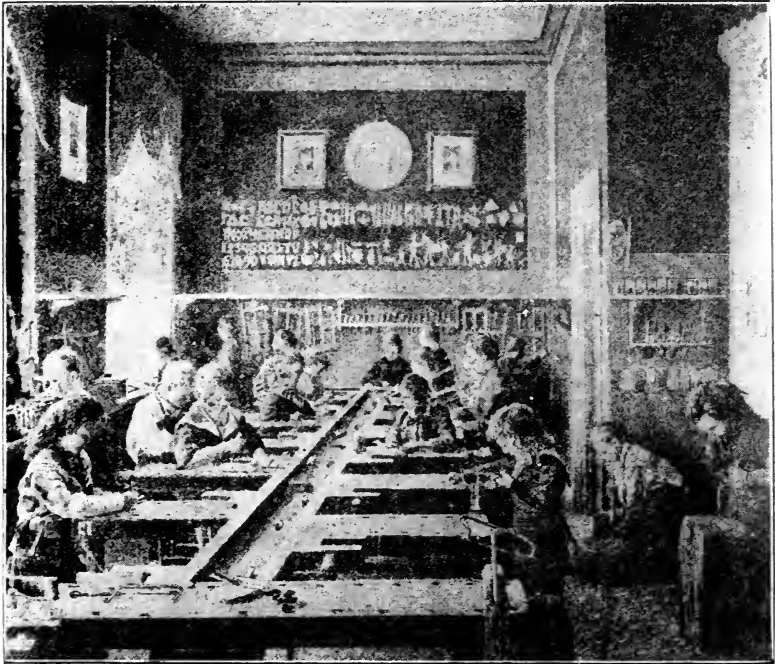

FIG. 40. EVA RODHE'S PRIMARY SLOYD ROOM, GOTHENBURG

pupils are crammed as much with book studies as are those of the children in the higher grades. Both need handwork to counteract the ill effects of continual book training. Holding this belief, she gradually developed what she called "primary sloyd." She went so far in her thinking as to claim that the sloyd was superior to the handwork of the kindergarten because all the work in sloyd was done while standing, thus providing opportunity for frequent change of position. (21—1)

As might be expected with such a purpose in view, Miss

Rodhe adopted ideas from both Froebel and Salomon. From Froebel, she took the classification of models: (a) forms of nature and the accomplishments of life, and (b) forms constructed by the methods of geometric drawing. From Salomon, she took the idea that all models were to be useful

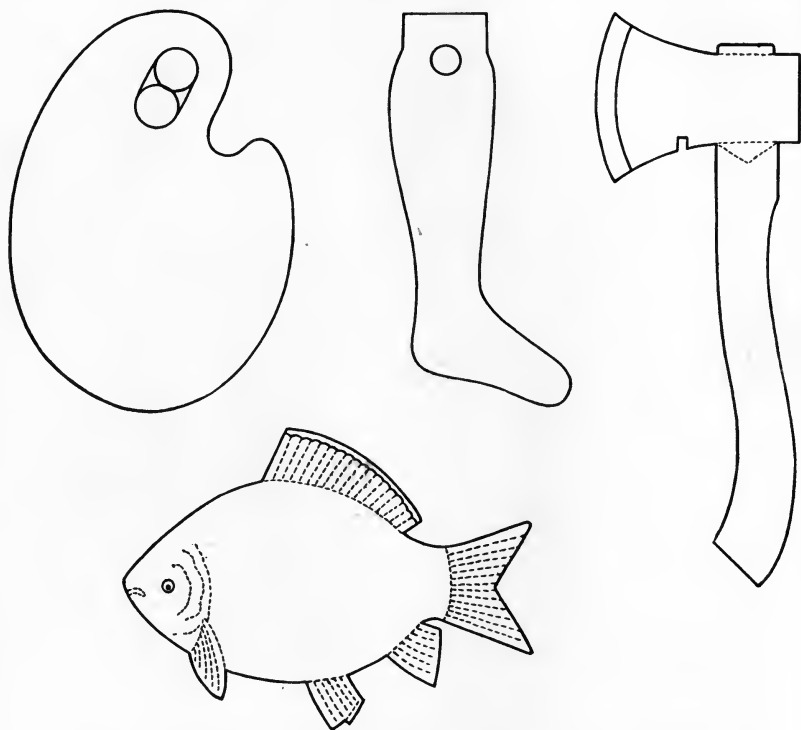

FIG. 41. FOUR "LIFE FORM" MODELS USED BY EVA RODHE

but, she added, not useful to adults. She would have each model useful to children; therefore playthings were included. All the models were made of thin wood, the first ones being from wood about 4 mm., or a little more than $\frac{1}{8}$ " in thickness. Owing to the methods of working, the woods used were birch and beech; the softer woods were not satisfactory. The chief tools used were a special saw, shaped somewhat like a coping saw but with much heavier blade and larger teeth. The file (flat, round, and half-round) was perhaps the next most used

tool. Then there was a variety of boring tools, tools for fastening pieces together, and finishing tools such as the small children could handle. The children worked at a special bench, Fig. 40, designed so as to be the right height and size

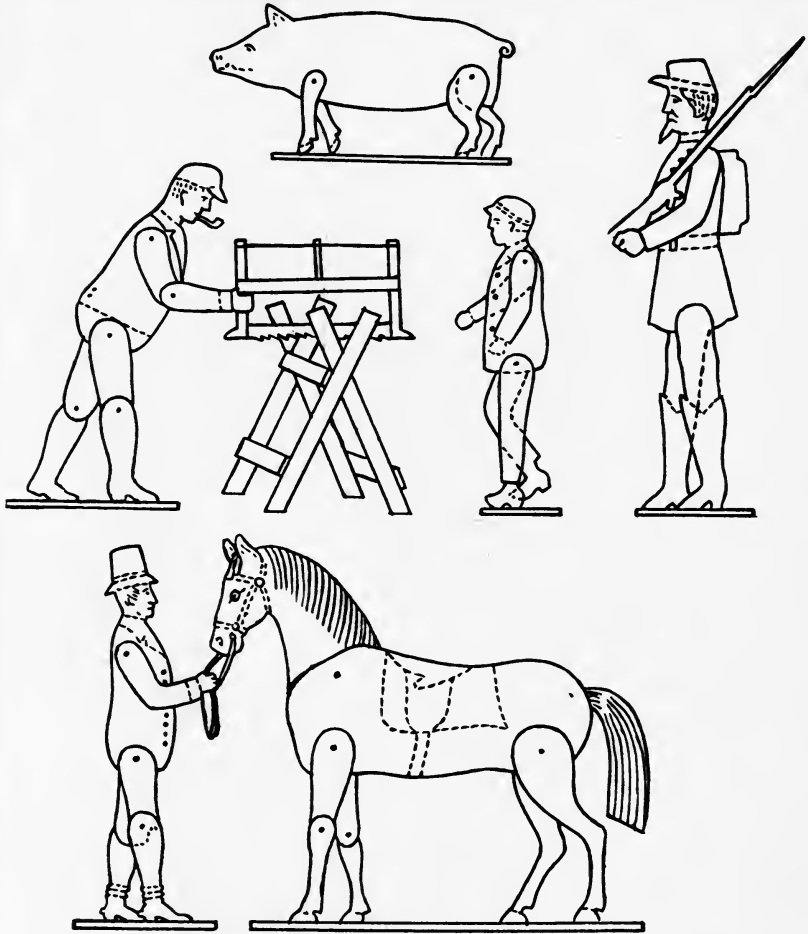

FIG. 42. JOINTED ANIMAL TOYS DESIGNED BY EVA RODHE

for the children and to occupy as little space as possible.

The children beginning this work were so young that they were not able to lay out or draw the forms of many of the models. Consequently they usually worked from sheet-zinc

patterns made for them. The fundamental steps for many of the early models were:

(1) Nail the zinc pattern on the piece of wood and draw a line around the pattern.

(2) Saw close to the line, keeping on the outside of it.

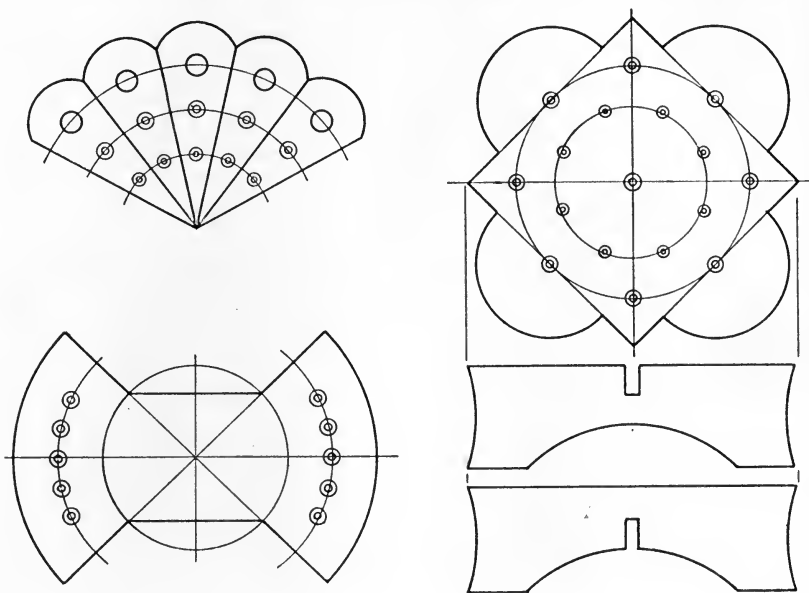

FIG. 43. MODELS ORNAMENTED BY COUNTERSUNK HOLES

(3) Finish these sawed edges with a file and then with sandpaper. (21—5)

The children were taught to saw with the left hand, and the course began with three exercises to learn the handling of the saw and the fact that wood has grain. After these preliminary exercises, the children sawed out strips and circular pieces of wood to use in their arithmetic lessons. Following these came the letters of the alphabet and the arabic numerals, some of them to be sawn out by each pupil. The numerals were made from zinc forms and the letters—block letters—were laid out geometrically. Then began the series of “life models”—toy pallet, toy stocking board,

cap and hat forms to be used for thread-winders, butter knife, paper knife, toy axe, candlestick mat in the shape of a maple leaf, toy chopping board in the form of a flat fish, letter opener in the form of a crocodile, and a penrack in the form of a snake, Fig. 41.

Beginning with the fifteenth model came the jointed animal toys for which the Eva Rodhe system is most widely known in America—the shepherd boy, the pig, the soldier, the rider, the acrobat, the wood sawyer, Fig. 42. Many of the later models of the course involved the boring and counter-sinking of holes as ornamental features. Fig. 43. The course ended with a cubical penny bank. (21—Flates)

23. Danish Sloyd. Educational sloyd in Denmark, as in the other Scandinavian countries, grew out of the domestic industries, and was delayed somewhat on account of the vigorous way in which these industries were promoted. The aim of the domestic-industries movement was “to procure for the country people, in places where the poverty of the soil made agricultural pursuits almost impossible, an additional means of earning a livelihood.” The leader in this movement was Clauson-Kaas, a retired cavalry officer. As a boy he “had been encouraged by his parents to fill up his leisure hours with all sorts of minor handicrafts.” As an army officer in an out-of-the-way garrison town, he was forced to teach his own children. A number of other boys joining with his own in the lessons, he resolved to add various kinds of manual work to the subjects of instruction. (22—69) Soon after he was pensioned, he removed to Copenhagen and “began to agitate for the extension of this form of instruction.” In 1871, he began to publish the *Nordisk Husflids-Tidende* (The Northern Journal of Home Industry).

In 1873, the General Danish Society for Domestic Industry was founded with Clauson-Kaas as secretary. This was intended to amalgamate all the societies for home industry in the nation. Clauson-Kaas then became the editor of a second magazine, the *Husflids Middelelser* (The Home Industry News). (22—70) While Clauson-Kaas began his work with an educational ideal in view, his later efforts were

chiefly in the direction of promoting domestic industry—handwork with an economic purpose. This purpose was accentuated by the patriotic revival after the loss of Slesvig to Germany in 1864.

The movement for domestic industries was opposed by the educators and public-spirited men who were in sympathy with the fundamental educational ideals of Cygnaeus and Salomon. Prominent among these was Ansel Mikkelsen, a manufacturer. In 1881, he began to teach manual work to his apprentices, and a few other children thirteen to fifteen years of age, with a view to general development. (23—VII) Two years later, in the town of Nestved, where he was principal of a technical school, he opened the first educational sloyd school in Denmark. In another two years, 1885, he went to Copenhagen, where he started, at his own expense, a sloyd school, and made it the center of agitation for sloyd as a means in general education. He also helped to start sloyd as a compulsory study in a private school. (24—493) In the spring of 1886, at the suggestion of Mikkelsen, the Danish Sloyd Association was organized whose aim was “to secure the introduction of pedagogical sloyd into both the higher and lower schools of the country.” The Association immediately received a grant of 6,000 crowns (\$1,608) from the State. About this time Mikkelsen purchased a convenient building which he equipped for a sloyd school, and, in August 1886, he opened a vacation course in sloyd for teachers. “Twenty-four male teachers and some female teachers” took this course. (24—493)

With the grant of public funds increased to 14,400 crowns (\$3,859.20), the Danish Sloyd Association continued to extend its influence and develop its training courses for teachers. In this way, it came about that the courses developed by Mikkelsen became the recognized Danish Sloyd System. While this system had many points in common with the system developed by Salomon, it also had several important points of difference.

In stating the aims of Danish sloyd, emphasis was placed on the fact that (a) sloyd was in sharp contrast with other

school subjects; it was practical instead of being merely theoretical; it set "to work faculties in the child that would otherwise remain unused in school." (b) It was the beginning of training for many occupations involving bodily labor. (23—1)

The general underlying facts and principles of the Danish system were:

1. The starting point of all sloyd instruction should be the natural interests of the child. (23—2)

2. The material used should be wood and the tools only those in common use. In general, the things made should be objects used in daily life, especially those that require a coat of paint to be finished. (23—3) "Polysloyd" was in disfavor because the school time for sloyd was too limited even to learn one kind of sloyd thoroughly.

3. The course of instruction should be organized so as to consist of (a) a small or limited number of groups of models and exercises progressively arranged, and (b) an unlimited number of coordinate or extra models. (23—3) It should be flexible to meet the varying needs of individual pupils.

In this respect it differed from both the Russian and the Swedish systems.

4. Preparatory exercises should precede the work of making the models whenever it is thought desirable to single out a particular process for practice, but the preparatory exercises should always be followed by the corresponding model. (23—3)

5. Both class and individual instruction should be employed. Class instruction should be employed in showing working positions, in demonstrating the proper use of the tools and the succession of operations, the correct construction, etc. "Class instruction does not mean that all pupils work the same model at the same time, but that all are working within the same stage of exercises. . . . The coordinate objects will afford sufficient material for what might be called 'side work,' i.e., the application of the same and the preceding exercises to other objects or models, whenever any

such arrangement should be found desirable on account of the children's unequal working power." (23—4)

This is a frank recognition of individual differences in workers and an effort to adjust the course of instruction accordingly.

6. In class instruction, the general appearance of a model or exercise piece and the general method of making it should be taught by showing the model itself and explaining it; whereas the details of construction and procedure should be taught through the use of drawings on the blackboard, which should be copied by the pupils into their notebooks. "The operations are formulated in short sentences which are taken down along with the design in the manuscript-book. If in spite of the regular repetition of the subject matter any single person be unable to master all of it, the teacher must give him special instruction founded always, however, on the notes taken down." (23—4)

7. Tools should be selected or especially constructed to suit the child's size and strength, and no tool should be used by a pupil until its use and "technology" have been fully explained. (23—5)

Several tools were designed by Mikkelsen and made to fit the hands of the children.

8. The marks of the cutting tools should not be "effaced by the finishing." Filing, sandpapering, and scraping should not be used till the pupils have gained considerable experience with the cutting tools and then only "with discretion." (23—5)

In the use of abrasives, the Danish sloyd was in open conflict with the Swedish.

The unusual analytical power of Mikkelsen was shown in his classification of the tools, tool processes, and exercises, and in the organization of the course of instruction. A striking fact in this connection was that exercises with the same cutting tool were grouped together. For example, during the first half year of the course, the only cutting tool was the saw, and the series of exercises and models was very minutely graded. Then followed two weeks of work

with the knife as the cutting tool. The rest of the first year and the first half of the second year were given over to the plane. This was followed by the spokeshave and turning saw. In the third year, the student learned to use the chisel, file, and sandpaper. This concentration of attention on one tool at a time showed what could be done with a very few tools. Mikkelsen had over one hundred models in which the saw was the only cutting tool. Many of Mikkelsen's models were such common objects as a fence, a gate, a stile, a frame, a door—all scaled down to convenient size for the pupils to make in the school shop.

SOURCE MATERIAL II, A

THE DECLINE OF HOME SLOYD

By A. Sluys, director of Normal School in Belgium

From *Manual Training in Elementary School for Boys*. Edited by Nicholas Murray Butler, Industrial Education Association Monograph, 1889.

Twenty years ago, complaints were made all over Sweden because domestic work (*Husslöjd*) which had once flourished throughout that country tended towards neglect and decay. The little farmer, together with his family—hitherto accustomed to devote long evenings to the construction of small objects, either for household use or for sale—showed less and less taste for work. This decadence is to be attributed to different causes; the chief being the application of steam to industry, which led to such a diminution of the selling price of household articles, that it no longer paid the peasant to manufacture them for his own use. Other results followed; the culture of the soil was improved, and the peasant gave to it more of his time and attention. Intellectual life made its needs more and more obvious, general education increased and the reading of books, magazines and newspapers became a favorite occupation, even among country people: children who went to school spent much of their leisure in study and the writing of lessons, to the detriment of domestic work. The religious movement in Sweden exerted an influence in the same direction: not only Baptists, Unitarians, and Methodists found many adherents in this country, but various other sects, such as the New Evangelists, etc., have risen in latter years, although according to the church laws they cannot pretend to self-government. From this cause, much time has been absorbed in religious observances. We must take note of still another cause of the decline of manual work. This was the prodigious development of the distilling interest in Sweden during the first half of this century. In 1800, the manufacture and sale of alcoholic drinks became free. This became a very large business and took the place of domestic work. During the first thirty years, it is computed that, outside of a hundred distilleries, more than 170,000 special houses were engaged in the manufacture and sale of alcoholic liquors. Retail sales were authorized by law. In these circumstances, a large part of the population became engaged during the leisure hours, in the production, sale, and use of *brännvin*. Among the working class, brandy was even regarded as currency, and taken in the payment of wages. The public health suffered from this excess; the number of crimes and public offenses increased; and as for domestic manual occupations, they ceased altogether. In 1855, a law was fortunately passed restricting the manufacture and sale of liquors. The public health was improved, crimes diminished, and gradually the people of the country resumed their domestic occupations and habits of work. In 1846, an association was founded which was an active propaganda of the *Slöjd*. About the same time, a well-known writer, M. Hedlund, published some articles in which he eloquently advocated the importance of this subject; but it was not until 1872, that the Swedish Government interested itself in this form of education. The Chamber of Deputies voted an annual subsidy of 2,500 crowns, which was raised first to 10,000 and

afterwards to about 27,600, in order to encourage communities and instructors who might wish to adopt the system. In 1875, the Royal Academy appointed the engineer, Albert Ranström, to organize temporary courses of Slöjd.

In six years, 147 courses had been given to 1678 persons, of whom 456 were primary teachers and 101 special professors. In 1877, the Chamber voted the sum of 15,000 crowns, intended solely to aid the public schools in which manual training was taught. The instructor who introduced this branch into his course received an annual subsidy of 75 crowns. The first efforts were not very successful. Almost everywhere they practiced wood carving, a work of little educational value, and a certain defiance was manifested toward the Slöjd. Fortunately, a more rational course was adopted in some places, and the work undertaken was of more serious importance. The schools of Nääs, Upsala, and Claestrop, set a better example and exerted a beneficial influence upon the country at large. A few figures will show with what rapidity this system gained ground in Sweden. In 1876, it was estimated that 87 schools had adopted this branch of education. In 1877, there were 100; in 1879, nearly 200; in 1883, 600; and in 1884, more than 700. This constant advance was owing in part to the efforts of some men of ability who were devoted to the cause. The sculptor, Charles Ahlborn, gave, from 1870 to 1875, about two hundred lectures in various parts of Sweden, and expounded the subject to more than sixty thousand hearers. Count Erick Sparre also made strenuous efforts to advance the movement. . . . In the beginning, the economic conception was generally adopted. Everywhere manual training was looked upon as a means of preparing the children of the common people to earn their living. But gradually the question took on its true aspect. It was recognized that manual training has a more elevated purpose, and one indeed more useful, in the deeper meaning of the term. It came to be considered as an educational process for the complete moral, physical, and intellectual development of the child. Thus was realized in Sweden the dreams of those illustrious teachers, Comenius, Rousseau, Pestalozzi, and Froebel, in seeing combined in the primary school program, manual training and the teaching of purely theoretical subjects, so as to ensure the integral cultivation of all the faculties and all the aptitudes which make up the complete man. (3—II, No. 1, Part I, 34)

SOURCE MATERIAL II, B

SLOYD IN THE COMMON SCHOOLS OF FINLAND

By Otto Salomon

Translated from *Slöjdskolan och Folksskolan*, Gothenburg, 1882.

Translation published in Second Report of the Royal Commissioners on Technical Instruction, London, 1884.

Without doubt, we can properly say that to this country (Finland) belongs the honor of having been the first, at the present day, to realize the idea of handwork as a regular exercise in the common schools. For its being so, Finland is under obligation to the founder of its public-school system, Uno Cygnaeus.

From his early youth, taken about by his father to various workshops, Cygnaeus had opportunity, when young, to acquire a general manual skill, of whose value and advantage he had good chances to convince himself during his shifting and varied life. Perhaps for that very reason, when, having arrived at manhood, he began his pedagogic studies, the philanthropic experiment occurred to him of introducing handwork into schools as an important means of instruction and cultivation. By thorough study of Pestalozzi's and Froebel's writings, the idea of handwork as a regular means of development gradually became clear to him. He conceived that, with the design of seeking to awaken the sense of form and beauty, there should be introduced into the school certain kinds of handwork which, unlike Froebel's play lessons, should be perfectly suitable for older pupils. With this intent, there should of course be no attempt in the common schools to acquire any great skill as artisans in the different branches, or, in respect of the articles made, to come in competition with men of the trade; but pupils should merely learn something of how to use their hands, and should acquire the habit of doing all their work neatly and methodically, making all the joints exact and the forms in good proportion and style. In his opinion, we should carefully guard against considering handwork in school, as recreation or play, rather than as an actual means of cultivation, and also against entrusting the instruction therein to artisans without any pedagogic training. Handwork must necessarily be put on the same footing with the other school work, and be conducted by a person of pedagogic education, and in the country public schools, wholly and with the proper aim, by the school teacher himself. At the seminary, he should gain both theoretical and practical knowledge in this subject, just as in others which enter into the program of common schools; that is, he should first get a just comprehension of manual exercise as a regular means of cultivation; and, secondly, he should learn such manipulations as are needful to enable him at least to guide and assist the pupils of common schools in this branch.

With this idea of the importance of handwork in common schools, which he had cherished ever since the middle of the year 1840, Cygnaeus, at the order of the imperial senate, in the autumn of 1858, undertook his pedagogic tour in foreign countries, visiting, on that occasion, Sweden, Denmark, Germany, Austria, Switzerland, and Holland. Whenever he met with teachers, he set forth enthusiastically and with the entire warmth of conviction his proposals of reform in matters of education, maintaining decidedly the great importance of handwork as a regular means of cultivation and the advantage of employing it as such. In consequence of an innate dislike of any appearance in public, it was mostly in private circles and before some interested persons that he sought to propound his pedagogic system, which comes very near to the principles of Pestalozzi, Froebel, and Diesterweg.

After his return home, being appointed inspector of public schools in Finland, in 1861, and director of the seminary established by him in Jyväskylä, opened in 1863, Cygnaeus was placed in circumstances to carry out in practice his ideas touching the use of handwork in the service of education. The statute of 1866, respecting the organization of the common-school system in the Grand Duchy of Finland, drawn up chiefly according to his recommendations, is certainly the first common-school ordinance which

adopts "technical handwork" as an obligatory exercise in seminaries, and slöjd for boys in the country schools. As a proof that this instruction is on the same footing as other subjects, it should be observed that the teachers thereof, in the seminaries, like the other teachers, have the title of "lector" (professor). In the seminaries, and partly even in the common schools, the instruction embraces joinery, carving, smiths' work, tin-plate working, and basket making. (10—V, 8)

SOURCE REFERENCES

1. Salomon, Otto—Nääs. Descriptive circular on the August Abrahamson Foundation and the School at Nääs, *Gothenburg*, 1904.
2. "August Abrahamson and Naas." In the magazine *Hand and Eye*. O. Newmann & Son, London, 1898.
3. Sluys, A. *Manual Training in Elementary Schools for Boys*. Edited by Nicholas Murray Butler, Industrial Education Association Monographs, New York, 1889.
4. Cronholm, Neander N. *A History of Sweden*. Two Volumes. Published by the Author in Chicago, New York, and London, 1902.
5. Watson, Foster. *The Encyclopedia and Dictionary of Education*. Sir Isaac Pitman & Sons, Ltd., London, 1921.
6. Farley, Allison A. "Swedish Sloyd—I." In *Manual Training Magazine*. The Manual Arts Press, Peoria, Illinois, 1907.
7. Monroe, Paul. *A Cyclopedia of Education*. The Macmillan Company, New York, 1911.
8. Smith, Donald, "The Origin of Modern Handwork Methods." *Practical Education and School Crafts*, London, 1924.
9. Salomon, Otto. "The Progressive Steps Taken by the Swedish Sloyd Instruction," *Educational Leaflet* No. 67. College for the Training of Teachers, New York, 1890.
10. *Report of the Consultative Committee on Practical Work in Secondary Schools*. Board of Education, London, 1913.
11. Ordway, John M. "Report on Handwork Instruction in Sweden." *Second Report of the Royal Commissioners on Technical Instruction*, London, 1884.
12. Salomon, Otto. *The Theory of Educational Sloyd*. Silver, Burdett and Co., Boston, 1896.
13. Salomon, Otto. "Sloyd Instruction in Sweden." *Pratt Institute Monthly*, 1898.
14. Salomon, Otto. "The Value of Gymnastics in Educational Sloyd Instruction." *Hand and Eye*. O. Newmann & Co., London, 1893.
15. Salomon, Otto. *The Teacher's Handbook of Slöjd*. Silver, Burdett and Co., Boston, 1904.
16. Nääs Modellserie for *Padagogisk Snickerislöjd*. Gothenburg, 1904.
17. Salomon, Otto. "Some Views Concerning the Arrangement of a Series of Models." *Hand and Eye*. O. Newmann & Co., London, 1894.
18. *Method and Procedure to be Followed in Making the Nääs Sloyd Models*. Gothenburg, 1903.

19. *Stockholm's Folkskolors Modellserie*. Stockholm, 1900.
20. Hammerstrom, A. "Educational Sloyd." *Practical Education and School Crafts*, London, 1925.
21. Nyman, Maya. *The Eva Rodhe Model Series in Woodwork*. (In Swedish and English) Gothenburg, 1893.
22. Goetze, Waldemar. *Illustrated Manual of Hand and Eye Training*. Translated from the German. O. Newmann & Co., London, 1894.
23. *The Danish Sloyd Guide* (to the exhibit of the Danish Sloyd Association at the World's Columbian Exposition, Chicago) Copenhagen, 1893.
24. *Industrial Education*. Eighth Annual Report of the U. S. Commissioner of Labor, 1892, Washington.

CHAPTER III

MANUAL TRAINING IN FRANCE

24. **The Historical Background.** In France, as in several other European countries, educational manual training grew out of an earlier type of shopwork instruction which was chiefly economic or industrial in its purpose. But, in France, the earlier shopwork was so definitely focused on providing a substitute for apprenticeship that when the general-education motive in the work became prominent the economic-industrial motive still persisted. One writer, in referring to France, says:

She has not only set herself to educate her people, but she has specifically set herself to adapt that education to the needs of the present industrial era. Ever since the establishment of the present republic, and especially since 1878, many of the ablest minds in France have diligently occupied themselves with the question how best to broaden the basis of general knowledge and, at the same time, introduce into the schools a kind of training best adapted to prepare youth to become intelligent workers in industrial pursuits. This practical aim has dominated every step. (1—430)

Another writer, after making a special study of manual-training and apprentice-school instruction in France, said:

In France there is absolutely no sympathy with any kind of manual instruction that pretends to aim at purely educational results and entirely ignores the industrial condition of the country. If there be such a thing as pure intelligence training, apart from economic conditions, it is natural to suppose that such time-honored subjects as Latin, drawing, etc., will suffice. So that there can be no adequate reason for the introduction of manual instruction into the schools, unless, in addition to the usual purposes of education, it aims at some object not hitherto attained to by other subjects. In France, this object appears to be a knowledge of and a preparation for industrial pursuits. (2—26)

These statements made before the year 1900 help to give significance to what follows.

When the French Revolution abolished the guilds because

they had become "trade aristocracies," the rulers of France already had before them an example of a successful trade school in the one established by the Duke of La Rochefoucault-Liancourt. Doubtless this was a factor in turning public attention to the school as a means of solving the apprenticeship problem, which very soon became troublesome. Accordingly, this trade school was made a national institution. A few years later Bonaparte was so favorably impressed with its work and so conscious of the need of more skilled workmen in France that he moved it into larger quarters and provided for its reorganization¹. In certain institutions created by individuals, associations, and municipalities, efforts were made to associate apprenticeship to a trade with the ordinary studies of the elementary school. As early as 1832, César Fichet began such an effort in a school in *rue Basse-du-Rempart*, Paris, where he installed school workshops. The practical instruction which his students received did not dispense with the ordinary apprenticeship but improved it considerably. The experiences in this school were sufficiently varied to make possible the discovery of the special aptitudes of children. By 1845, manual instruction was given in fifteen elementary schools in France and the Minister of Public Instruction recognized the need of securing a more general adoption of this new type of school. (3—3) The revolution of 1848, however, and the political disturbances that followed, by 1851, had put a stop to this progressive movement; though it did not cause the leaders to cease their efforts. (3—2)

Meanwhile, under other auspices, progress was being made in the development of trade schools and schools of technical instruction for boys and girls of about twelve years of age and older. In 1827, the School of Christian Brothers of Saint Nicholas was established in Paris. (4—38) In 1831, La Mertinière School for boys and girls came into being in the old Augustine Monastery at Lyons as the result of a bequest of one, Major Martin, a native of Lyons, who amassed

¹Bennett, Charles A. *History of Manual and Industrial Education up to 1870*, p. 276.

a large fortune in India and stipulated in his will that his wealth be used to establish three schools, one at Calcutta, one at Lucknow, and another at Lyons. (4—39) In 1838 an apprenticeship school was founded at Nantes. (5—259) Livet Institute, also at Nantes, was founded in 1846. (5—272) In 1852, the Eastern Railway Company opened an apprentice school in Paris. (5—279) The trade school of the Chaix Printing Company in Paris was started in 1863. (5—278) In 1864, through the initial efforts of Madame Elisa Lemonnier, an industrial school for girls was opened in Paris under the auspices of the Society for the Industrial Education of Women. (5—281) In the year 1863, the government of France appointed a national commission on technical education. The report of this commission in 1865 brought to public attention again the importance of industrial education and emphasized the place of the school in such education. In 1868, a municipal school for apprentices in the leading skilled mechanical trades was opened at Havre. (5—253). The Diderot School, the famous municipal school for the machine trades in Paris, was opened in 1873. (5—247)

As these private and special schools grew in number, the discussion of manual instruction in the public schools continued to be more favorable. A public minister, Victor Duruy, is reported to have said, in 1866, "I do not think it possible to place the workshop in the school, at least in ours; but I think that it is possible, in a special college, to undertake the education of the hand, just as the ear is educated by music, the eye by drawing, and the whole body by gymnastics." (2—8) The next year, 1867, the director of the training college at Cluny, made the following analytic statement:

The introduction of manual work into an educational establishment can have two ends in view—either to prepare the pupils for a special calling, or to put into play their physical faculties, the prevision of the eye, the dexterity and suppleness of the hand, and to oblige the pupils to reason and reflect, whilst at the same time it causes them to know the application of theory to practice, as well as the advantages of both. At first general manual work would appear to be very complicated, but if what is done in the arts and manufactures be closely examined, it is found (1) that the certainty of the hand,

and the facility to rapidly execute a series of movements, however precise, constitute the foundation of every calling; (2) that there is a small number of tools which are the type of all others, and he who knows how to manage them indeed knows what there is that is essential in the exercise of numberless professions. Thus the work upon which rests a great number of special industries is above all work in wood and work in iron. (2—8)

25. **The Salicis School.** All the schools mentioned above were of the apprenticeship, trade, or vocational type. What



FIG. 44. SALICIS SCHOOL

is appropriately considered the pioneer manual-training school in France was opened in 1873 in a modest building at 33 *rue Tournafort*, under the general supervision of Gustave Adolphe Salicis (1818–1889), for whom the school has since been named. The director or principal of the school was D. Laubier. Although the date given for the opening of the school is 1873, the real origin dates back to the Franco-Prussian war of 1870. During the siege of Paris, Salicis, whose training had been in the *École Polytechnique*, in the Navy, in military service in Morocco, and later as an officer in the Crimean war, was made one of the sub-commanders in

charge of the fifth *Arrondissement*. While in this position of authority, he sought employment for “the numerous children who were left without occupation as well as for the teachers who had been compelled to withdraw from the suburbs of the city.” (6—21) Bringing children and teachers together, he started the manual-training school which survived the siege and became the famous *École Salicis*.

The front of this historic school building, as it appeared

in 1909, is shown in Fig. 44. Back of this facade was a court and back of the court was the workshop, Fig. 45, on the front of which had been placed a memorial to Salicis. The interior of the workshop is shown in Fig. 46. It was this shop, opened in 1873, that antedates the educational sloyd of Salomon in Sweden by four years, of Mikklesen in Denmark by ten years, of Schenckendorf in Germany by



FIG. 45. WORKSHOP BUILDING, SALICIS SCHOOL

eleven years, of Professor Ripper in England and Dr. Woodward in America by seven years. As shown in the illustration, the photograph for which was taken by the author in 1909, the equipment of this shop had been unmolested since its opening, except for slight repairs made necessary by constant use.

A first fact to be noticed in the equipment of this shop is that it provides for both woodworking and metalworking. The latter occupies the benches at the right and the section at the far end of the room where there is an anvil and a large, simple forge with leather bellows. Each working place at a bench is provided with six files of assorted shapes and sizes, two hammers, one hand vise, and dividers. For general use there were taps, dies, die wrenches, tongs, and a hand-power drill press. The eight woodworking benches

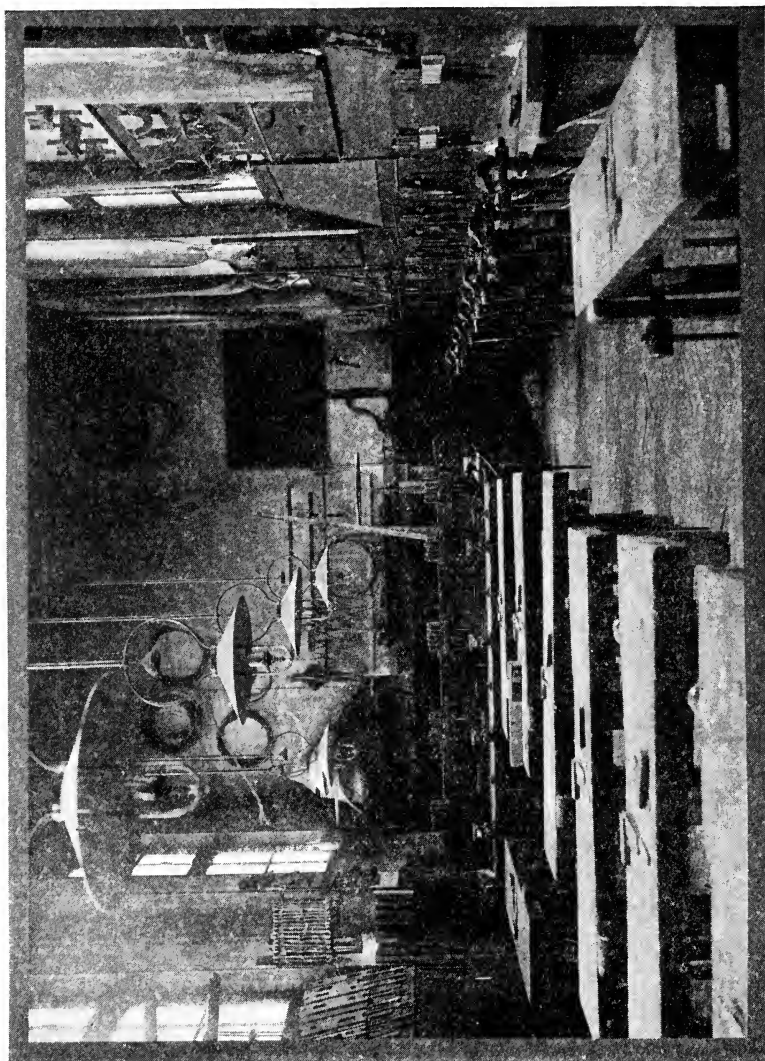

FIG. 46. WORKSHOP, SALICIS SCHOOL



FIG. 47. DRAWING ROOM, SALICIS SCHOOL.

are quite large and heavy and each is provided with an ordinary carpenter's vise. Most of the woodworking tools were kept in tool racks on the left-hand wall of the room. A small grindstone and a glue heater were in one corner. Adjoining the shop was a classroom for drawing, Fig. 47, equipped with board rests and footrests made of iron pipe, and seats with metal legs. To the uprights of the board rests were fastened clumsy wooden trays to hold pencils and instruments.

Another room for drawing was located in the main school building. This one, however, was equipped with simple wooden school desks. A room, also in the main building, was equipped for work in clay modeling. (7—XII, 145)

This school took boys of upper-elementary school age and gave them some instruction in shopwork, modeling, drawing, and technology in addition to their regular elementary school studies. In the year 1888 there were four groups or classes of such pupils and they were given work in the manual arts for the number of hours a week indicated in the following table:

<i>Classes</i>	<i>I</i>	<i>II</i>	<i>III</i>	<i>IV</i>
Drawing	3	2½	1	1
Modeling	3	2	2	2
Woodwork and Metalwork	3	3	2	1
Technology	1½	2½	2	3

(8—17)

It should be noticed that in this table woodwork and metalwork are grouped together. This has been characteristic of elementary manual training in Paris. The two were usually in one shop, were taken in the same course and alternately. In this respect, as in many others, the Salicis School set the early standard for the public-school system of the city. What was regarded as a significant fact was that pupils passing through these courses were able to make fully as high records in the regular academic subjects as pupils of corresponding grade in the regular public schools.

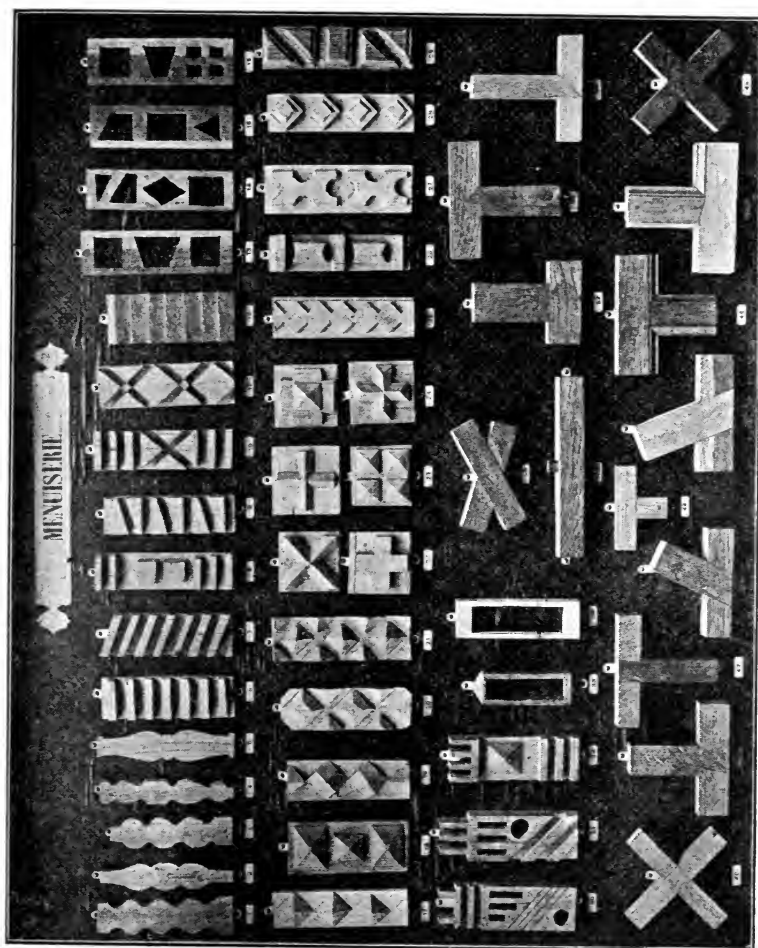

FIG. 48. WOODWORKING COURSE, SALICIS SCHOOL.

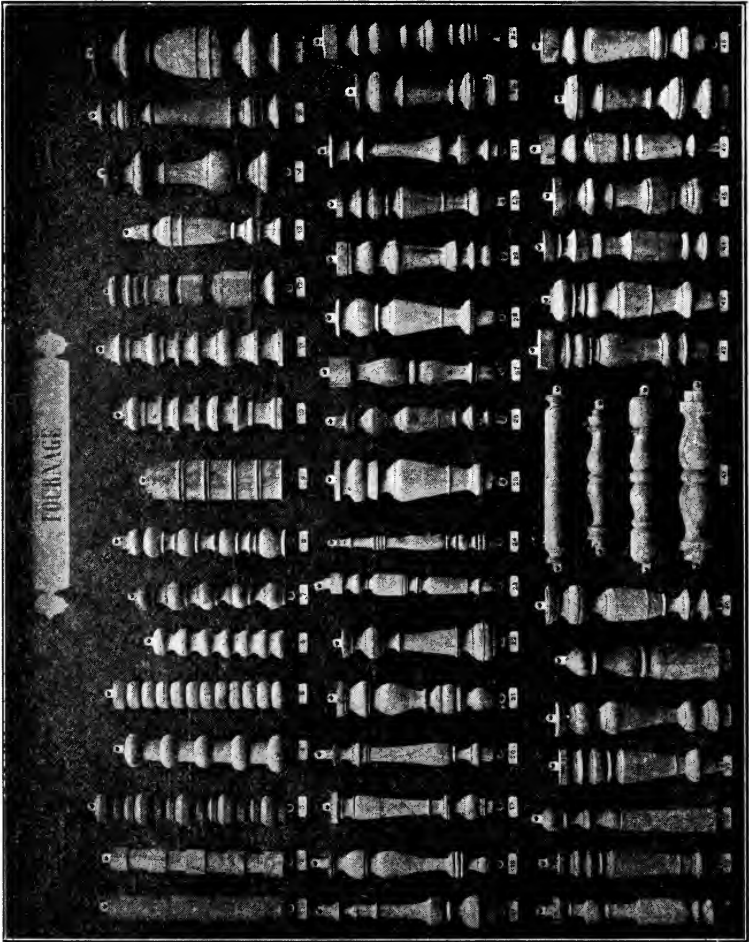

FIG. 49. WOOD-TURNING COURSE, SALICIS SCHOOL



FIG. 50. METAL FILING AND FITTING COURSE, SALICIS SCHOOL

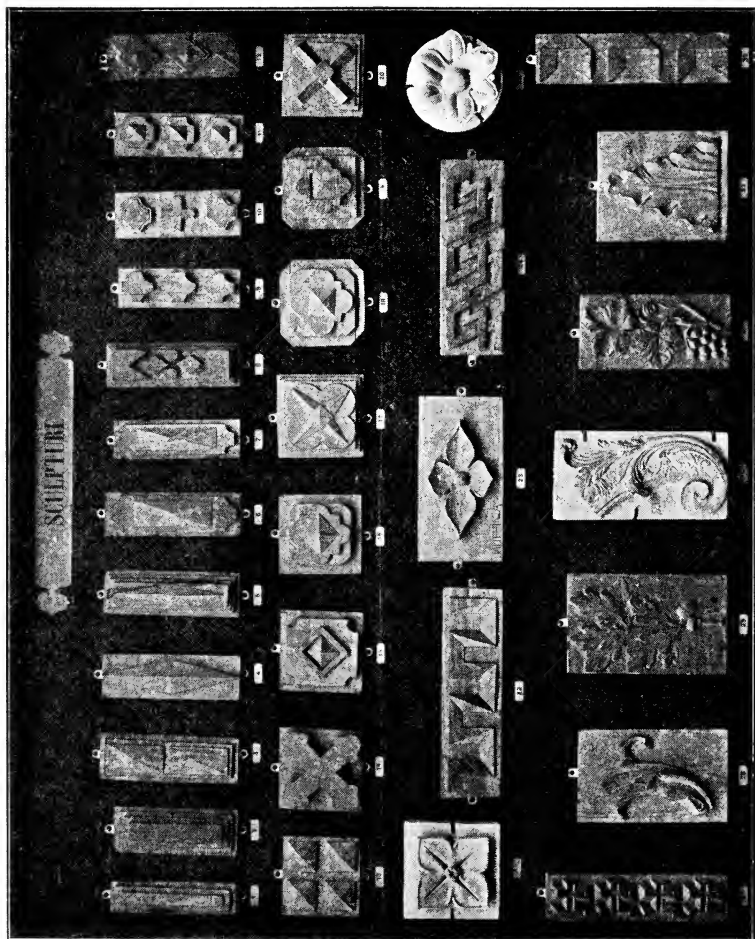

FIG. 51. WOOD-CARVING COURSE, SALICIS SCHOOL

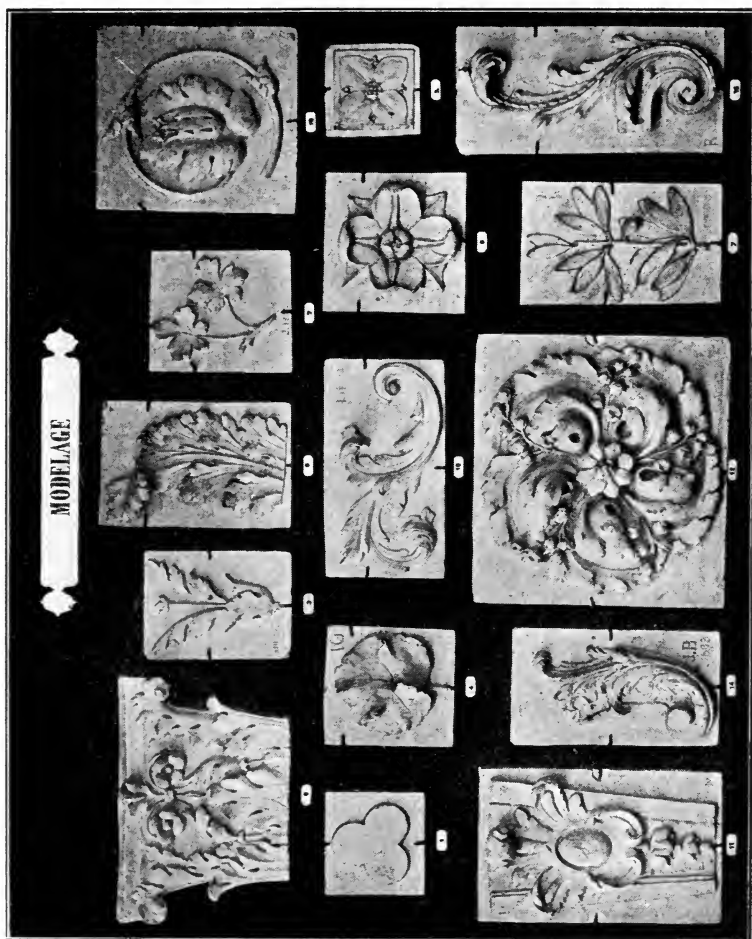

FIG. 52. CLAY-MODELING COURSE, SALICIS SCHOOL

In this school, also, there was another and more advanced class of boys taking a course that was more definitely trade preparatory or prevocational in character. This course was intended for boys who had definitely decided to learn a manual trade. In this course, so far as the manual arts were concerned, a boy was given a choice between modeling, wood carving, and sculpture, on the one hand, and wood joinery, wood turning, and metalwork, on the other. The

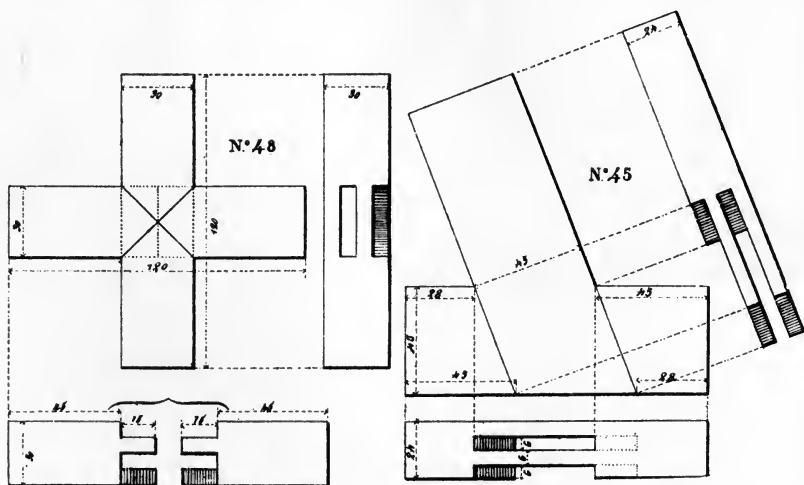

FIG. 53. WORKING DRAWING, SALICIS SCHOOL

amount of time given to these subjects was three hours a day. The course included arithmetic, the metric system, geometry, geography, and the elements of physics, chemistry, mineralogy, botany, zoology, hygiene, anatomy, and archaeology, also the French language and penmanship, drawing, music, morals, and gymnastics. (8—17)

The courses in shopwork as given in 1888 are shown in Figs. 48, 49, 50, 51, and 52. The general method of teaching the manual arts in this school in 1909 was for the teacher in the drawing class to make on the blackboard a working drawing of one or more of the shop exercise pieces, such as Fig. 53. The pupils copied these drawings in their notebooks and then copied them again, making mechanical drawings

in ink. After this the exercise was worked out in the shop.

The fact that the courses in this school were so definitely organized to give skill can doubtless be attributed in part to the circumstances under which the school developed, but especially to the viewpoint of the first director, M. Laubier, who started life as a mechanic and "could well appreciate the advantages derived from systematic teaching in hand-work." (4—35) All the shop teachers in this school were expert mechanics.

26. Manual Training in the Elementary Schools. It is a significant fact that the same law that made elementary education compulsory in France included manual training in the required curriculum. This was the law of 1882, which marked the triumph of republican ideals under the leadership of Jules Ferry (1832—1893), then Minister of Public Instruction, who, for several years vigorously opposed the influence of the clergy and insisted on free public schools in which moral instruction and training for citizenship should take the place of distinctly religious teaching. The leaders in this movement were helped in their efforts by the Paris Exposition of 1878, which made the French people realize that "if they were not to fall behind in the march of modern industry, they must infuse more of the modern spirit into their public schools." (1—435) In this connection it should be recalled that the Russian system of tool instruction was effectively displayed at this exposition. (cf. 7)

One of the important questions that had to be solved was whether manual training should be an integral part of the public-school system or be established under a separate system, financially and administratively. Consequently, in March, 1880, a strong commission was appointed to answer this question, after studying its many phases. Senator Corbon was made president of the commission, which soon divided itself into two sections: one to consider manual training in elementary schools (*écoles primaires*), with Senator Corbon as chairman, and the other to make a study of apprenticeship or trade schools, with Senator Tolain as chairman. (1—436)

The Corbon report (Source Material III A) was made in 1879 and immediately, even before the compulsory law was passed, manual-training shops began to appear in the public schools of Paris. In 1880, twelve had been opened; in 1881, there were 27. After the passage of the compulsory law, the number increased still more rapidly. In 1883, there were 67; in 1888, there were 99. (9—115) But the manual-training program recommended in 1881 provided not only shopwork for boys of the upper grades but some form of handwork for both boys and girls from the beginning of the infant school (*école maternelle*) to the end of intermediate school (*école primaire supérieure*). It began in the infant school with sense training through such playthings and industrial occupations as had been developed in harmony with the ideals of Oberlin and Froebel. In the primary grades, geometric construction work with paper and cardboard, basket weaving, modeling geometric and architectural forms, making simple objects with wire or wood and wire, were recommended in addition to freehand drawing and the arrangement of forms as a preliminary to the study of design. In the upper grades of the elementary school, drawing and modeling were to be continued and shopwork added for boys. This was to consist of the elements of joinery, wood turning, and metalwork. In the intermediate school, more advanced shopwork with a purpose to develop considerable skill and accuracy in the use of the more common tools for working both wood and iron were advocated, and a course of instruction outlined. In the three years of this school, drawing and modeling were to be continued. (1—432, 434)

During the period from 1882 to 1891, the instruction was given by artisan-teachers appointed after investigation, but without examination, and paid at first by the day and later by the year for fifteen hours of work per week. This shopwork, which at first took place outside of the regular school hours, was included in the regular schedule for the first time in 1886, thus more fully recognizing its obligatory character as intended by the makers of the law of 1882. (9—115)

In 1891, a new ruling was made concerning manual training

in the public schools of Paris. Critics had pointed out that it was too much like apprenticeship; that the intelligence of the pupils was not called forth; that drawing, its natural foundation, was excluded; in short, that it remained isolated, in no way relating to the other subject matter taught in the schools. It was also pointed out that the models were not adequately graded. (9—116) (See Source Material III B)

As early as 1888, a special commission was therefore named to consider the matter. On this commission were Salicis, who since 1885 had been the national inspector of public instruction, charged with the duty of working out courses of study in manual training for normal and elementary schools, and René Leblanc, who succeeded Salicis after his death in 1889. Modifications were made in the organization of 1880 which, in reality, constituted a complete change of method. Under the new plan the part of the classroom teacher, or class master or *professeur*, became quite different. He (for the teachers of the upper-grade boys were men) cooperated in the instruction, even to the extent of having a dominating part in it, preparing the lessons, assigning and criticizing sketches, furnishing necessary technical explanations, and leaving to the artisan-teacher, his assistant, only the task of supervising the execution of the work and directing the hands of the children. At that time, also, there was a change from individual to class instruction, all the pupils doing the same exercise at the same time. Drawing was made the foundation of all instruction, from the primary to the upper grades; no matter what the exercise or kind of work; whether in paper folding, weaving, woodwork, or ironwork. (9—116)

Before adopting these new measures, they were placed on trial in several schools and very closely watched. This gave proof, it was said, of the superior pedagogic value of the new method, particularly from the educational point of view. When the result was submitted to the municipal council in December, 1891, action was taken requiring that the new system of manual-training instruction be made general throughout the city of Paris, beginning in 1892. Wood turning was discontinued and the number of artisan-teachers

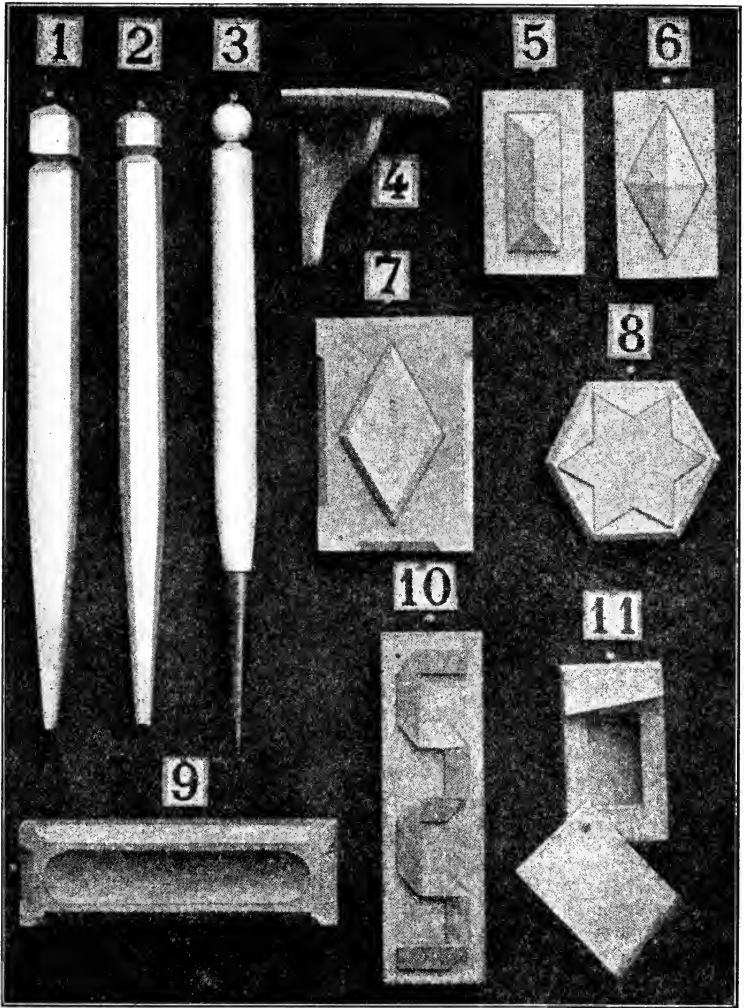

FIG. 54. BEGINNING COURSE IN WOODWORKING RECOMMENDED BY RÉNÉ LEBLANC

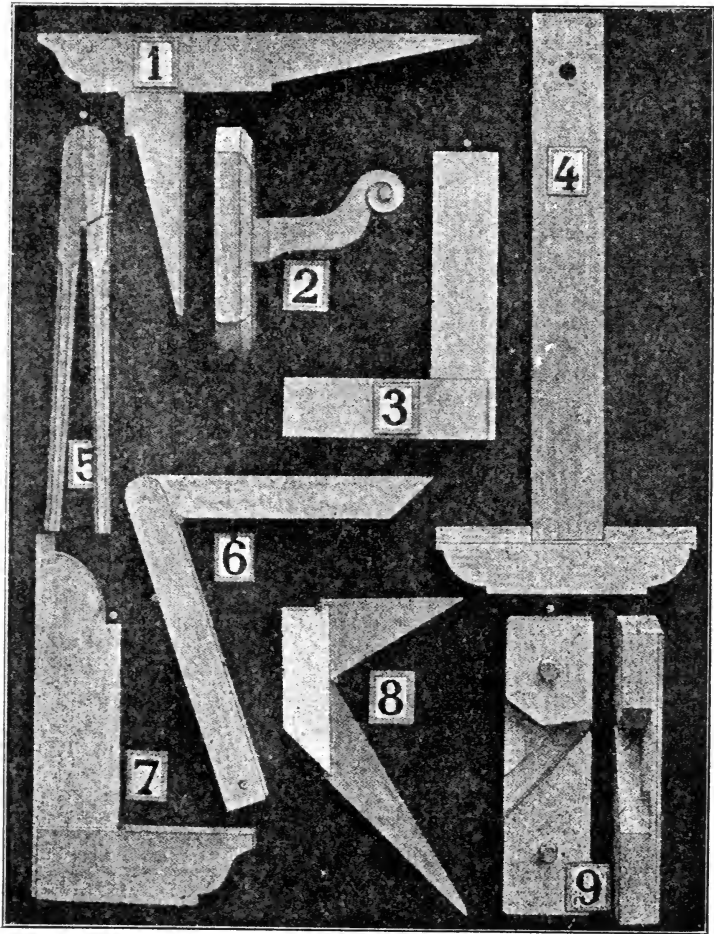

FIG. 55. ADVANCED COURSE IN WOODWORKING RECOMMENDED BY RENÉ LEBLANC

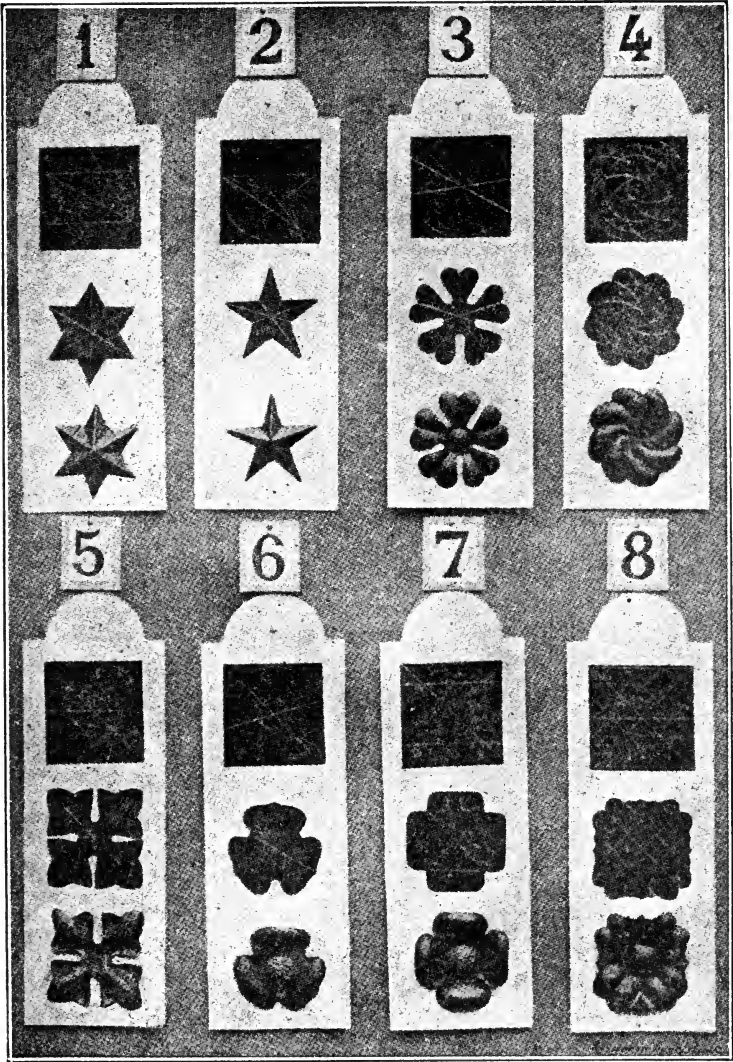

FIG. 56. COURSE IN RAISED SHEET METAL RECOMMENDED BY RENÉ LEBLANC

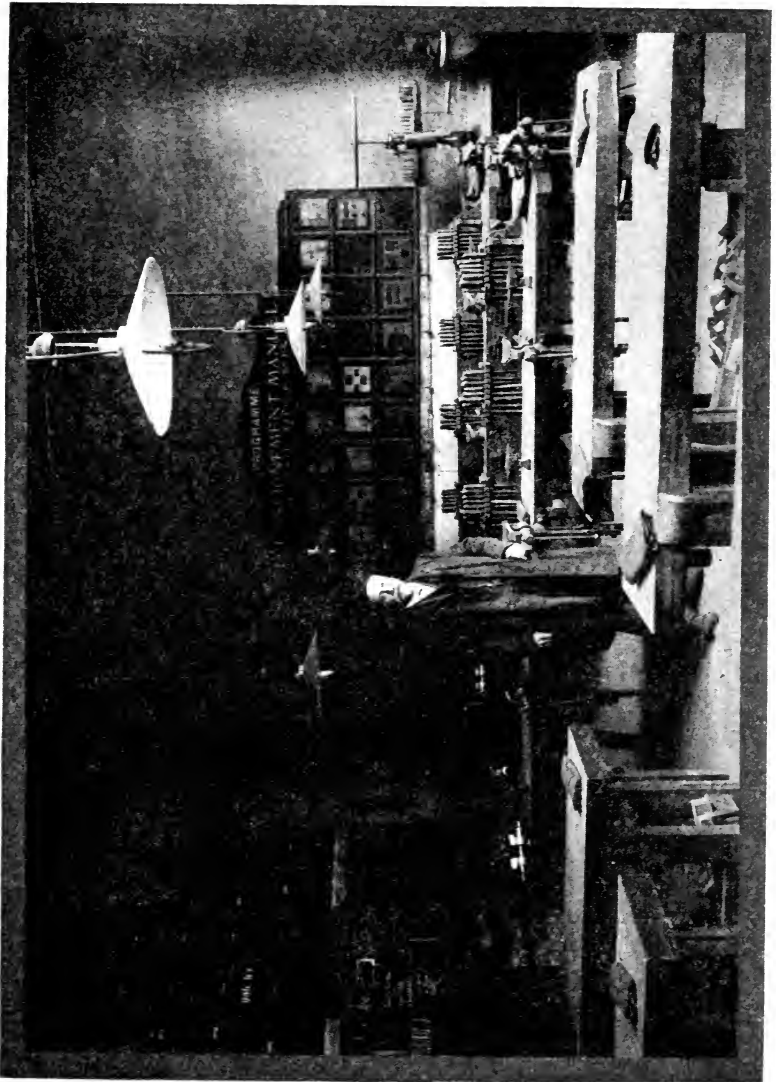

FIG. 57. WORKSHOP, PUBLIC SCHOOL, RUE ST. MAUR, PARIS

in any one school was reduced to two—one for woodwork and one for ironwork. The reasons given for discontinuing the wood turning were, "Wood turning tools require delicate use. For this, much practice is necessary. With the small number of turning lathes in use, the results are inconsiderable.



FIG. 58. WORKSHOP BUILDING, PUBLIC SCHOOL, RUE
ST. MAUR

Finally, turning is too fatiguing for children of twelve or thirteen years." (9—117)

Under the new system, with the regular classroom teacher as the dominant factor, the manual training was correlated with the other subjects and became in reality an integral part of the school. The connection between geometry and drawing was made especially close. (10—199)

The character of the woodworking course recommended by Leblanc is shown in Figs. 54 and 55. (See Source Material III B) Raised work in sheet iron (*tôle repoussé*), also showing correlation with geometry and drawing, is shown in Fig. 56. (3—99, 107, 111) The woodworking end of one of the early shop equipments is shown in Fig. 57. The exterior of this shop, Fig. 58, gives evidence of at least the physical isolation

of the shops in the early days. This shop is in the far corner of the play court in the rear of the school building. Fig. 59 reveals some of the facts concerning one of the larger and more modern shops for metalworking. The date of this is about 1900. At that time, similar large shops were available for woodworking. At that time also, the course of instruction in

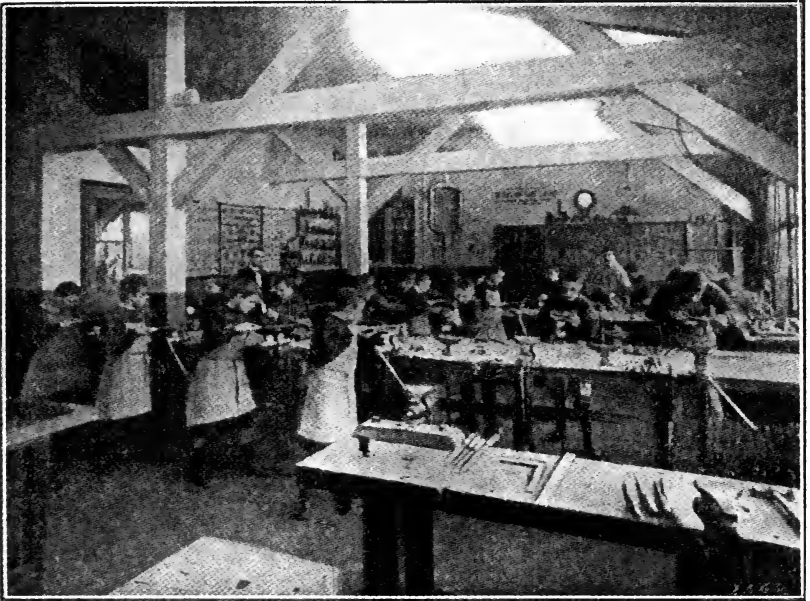

FIG. 59. METALWORKING SHOP, PUBLIC SCHOOL, PARIS

shopwork in the city of Paris, which, since 1889, had been developing under the supervision of A. Jully, had become enriched through more applications of elements of construction to objects of use and beauty. Fig. 60 shows some of the finished pieces of student's work in both wood and metal which were sent to the Franco-British Exposition of 1900. The amount of time given to the shopwork at that time was two hours a week. A half hour a week additional in the lower class was given to geometric drawing and a full hour in the upper class. (9—119) The general method at this time was for the pupils to make sketches in the classroom under the direction

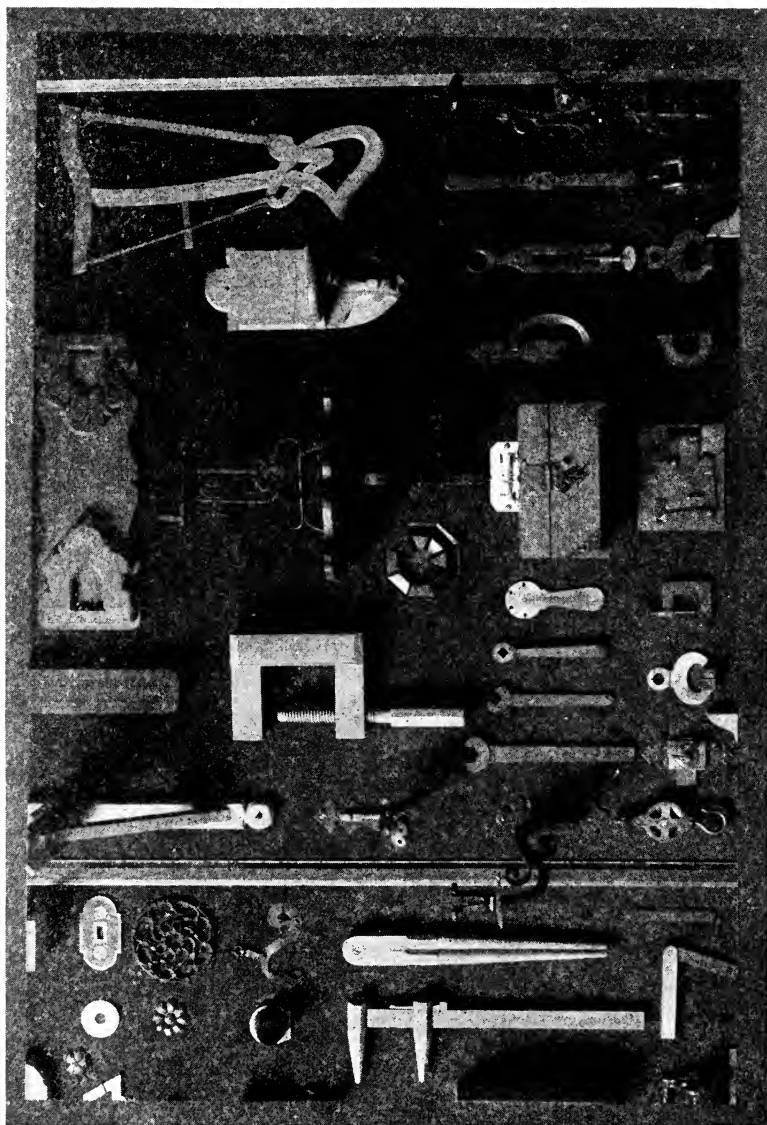

FIG. 60. PART OF THE PARIS EXHIBIT SENT TO THE FRANCO-BRITISH EXPOSITION AT LONDON, 1900

of their room teacher. Then they would pass to the shop where they worked them out under the guidance of the assistant, who was an artisan-teacher. Regular class teachers holding certificates of ability to give instruction in manual training—for the most part mechanical drawing—enjoyed the distinction of having a small amount added to their salary. Each month the school principals received from the inspector of manual training a program of work to be done during the ensuing month. (9—119)

27. Teachers of Manual Training. Referring to the provision for compulsory instruction in manual training in France, Salicis said, "Far from being well under way in 1882 with this worthy end in view, all preparations for the journey had still to be made; methods, buildings, stock of tools, body of instructors—all this coupled to the great obstacle that, on making the new studies obligatory, it had been forgotten to make any appropriations for them." (11—90) About the time the law was passed, Salicis was commissioned by the Government to make a study of manual training in the other European countries and to organize in Paris a normal school for teachers of manual training. In this he had the backing of Jules Ferry, minister of public instruction, and other officials. For the first class, forty-eight young school teachers, graduates of the University of France, were selected by competition. These young men were given a one-year course covering the following:

1. Experimental physics and chemistry as illustrated in simple phenomena, i.e., such experiments as might be repeated in elementary schools; the instruction was collective but the students had the privilege of individual manipulation.
2. Natural history, treated in the same way.
3. Plane trigonometry, algebra, and elementary mechanics.
4. Descriptive geometry with direct applications to perspective and to stereotomy.
5. Drawing, modeling, molding, and graphic designing.
6. Treatment of wood at bench and turning lathe.
7. Treatment of iron in the smithery, with vise and turning lathe.
8. As subordinate studies; choral music, French literature, fencing, and ~~the~~ practice. . . .

From an essentially manual point of view it covered about the following ground:

Stereotomy: Design and construction of a soffit, of a full center, of a segmental arch, of a stilted arch, of a rampant arch; development of the same; stringer of a staircase.

Drawing and Modeling: Rendering of twelve models selected from the collection of the National School of Fine Arts. No modeling was done, unless preceded or followed by a design of the object.

Joinery: Besides preliminaries, twenty exercises in joining and ten summaries (models).

Smithery: Introductory details, fire building, striking in presence of one, two, and three smiths, welding, rolling, measuring the caliber, tempering.

Millwright's work: Practice in using flat and half-round files, mortise chisel, graver, saw.

Wood-turning lathe: Railings of different styles, Medicis vase.

Metal-turning lathe: Slide cylinder.

Every object made was to be a material rendering of an off-hand sketch. A memorandum of each sketch was entered in a special workshop notebook, along with the teacher's private explanations and estimates. (11—91, 92)

In two years, this school graduated seventy-two teachers of manual training, who were given a special Government certificate created in 1883. Then, in 1884, because of a change in the minister of public instruction and his different point of view, the school became a part of the higher training college at St. Cloud. Here it was coldly received, but Salicis "continued his efforts, and in less than three years he succeeded in establishing in most of the training colleges workshops for wood and iron, a room for modeling and a chemical laboratory." (6—23)

Salicis was made an inspector of public instruction in 1885. "In 1886 official directions of a provisional nature, as to manual instruction at training colleges were issued. They were followed in January, 1891, by a scheme with a detailed syllabus of manual instruction for a three years' course." Three hours a week in each year were assigned to the subject and it was further directed that students of the second and third year should teach the first-year course to children in the elementary school attached to the college. In the training college as in the elementary schools, the professor of manual training was assisted by a master workman whose duty it was to keep the tools in good repair, to prepare and distribute materials, and to give such practical hints to the students as

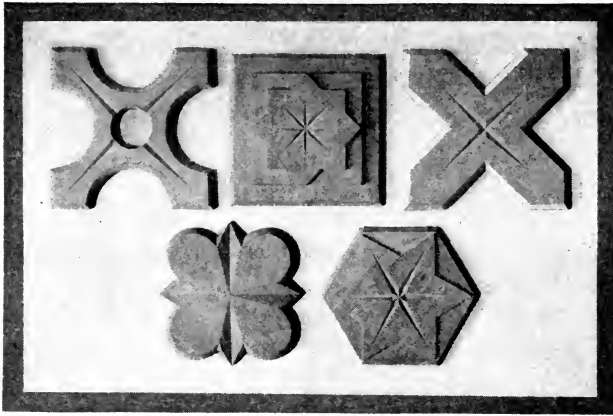

FIG. 61. REQUIRED WOODWORK, FIRST YEAR, NORMAL COURSE



FIG. 62. REQUIRED WOODWORK, SECOND YEAR, NORMAL COURSE

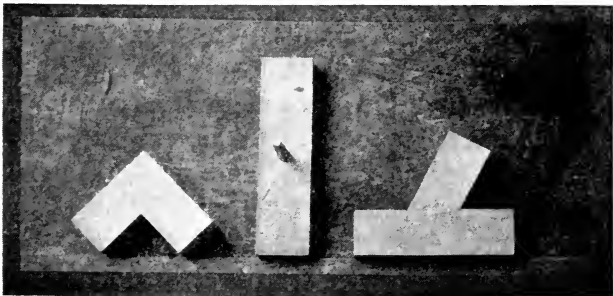

FIG. 63. REQUIRED WOODWORK, THIRD YEAR, NORMAL COURSE

would enable them to carry out the directions of the professor. The college students were examined on both their manual skill and their ability to teach—not the shopwork, but the drawing, science, and mathematics in their relation to shopwork. (6—23)

As a typical example of the course of instruction in shopwork in a normal training college, the one at the school at

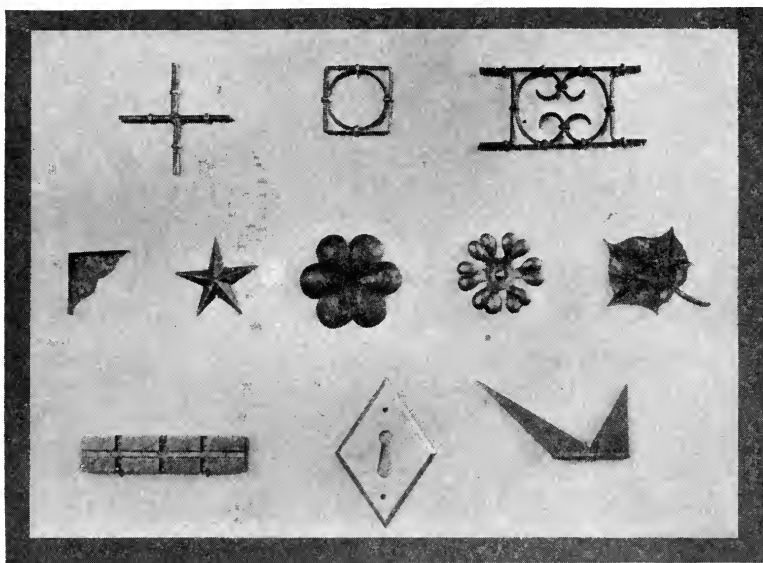

FIG. 64. REQUIRED METALWORK, THREE YEARS, NORMAL COURSE

Auteuil in Paris is taken. In 1909, the required woodwork of the first year consisted of the five exercises in beech wood shown in Fig. 61. The four joints in Fig. 62 represent the second-year requirement and the three in Fig. 63 the third year. Fig. 64 shows the required metalwork of the same three years. In addition to these required pieces, many of the students made very interesting and useful supplementary pieces comparable to those shown in Fig. 60. The equipment of the shop in this college was similar to that of shops in elementary schools except that, in this one, there were foot-power lathes in addition to the usual benches and tools for work in wood and iron. (7—XII, 167)

Because there was a shortage of upper-grade teachers qualified to give the theoretical instruction in connection with the manual training, the City of Paris opened classes to fully qualified teachers of other subjects. These classes were held on Thursday (the no-school day) and on Sunday afternoons. In these classes, in 1900, instruction was given in pedagogy, descriptive geometry, geometric drawing, modeling, woodwork, ironwork, and technology. Out of these classes have come many who have received certificates for teaching in normal schools and the higher elementary schools.

SOURCE MATERIAL III, A

MANUAL TRAINING IN THE PUBLIC ELEMENTARY SCHOOLS

By Senator A. Corbon

From Report to the Prefect of the Seine, 1879

Monsieur, the Préfet, you appointed a commission for the investigation of two correlative questions of the highest interest and the solution of which might well mark a happy revolution in the method of developing the moral, intellectual, and physical force of the youthful generation. One of these questions is to ascertain whether it is necessary and in what measure it would be possible to organize the workshop in the primary (elementary) school. The other is to know how the school can be continued in the workshop during the course of apprenticeship.

The commission met a few days after its appointment and began its work. It has devoted many sittings to the examination and discussion of the two-fold question presented to it, and has unanimously agreed: (1) that it would be well to attach a workshop to every primary school, in order that the pupils might there obtain manual training; (2) that there is room and need for the creation of apprenticeship schools, upon the plans of that already existing in Paris on the *Boulevard de la Villette*: (*Ecole Diderot*). After reaching this conclusion, the commission resolved itself into two parts, each to consider and report separately upon one of the questions proposed. The present report relates to primary schools.

The full commission considered, at the outset, whether the introduction of manual training into the primary school ought to be regarded as chiefly for the purpose of professional instruction, or as the necessary completion of a rational education. It declared itself strongly in favor of this second view. It understood that the practical teaching of various trades in the primary school would be almost impossible. In order to give such instruction, workshops would be required adapted to all, or at least to the principal, industrial pursuits carried on in a city, which would require a plant three or four times larger than that occupied by the largest of our present school establishments. This consideration would not be absolutely conclusive if children, on leaving the primary school at twelve or thirteen years of age, after learning more or less fully the elements of a trade, could find employment in industrial establishments as workmen, or novitiate workmen; but their youth and their physical weakness would, in most cases, prevent this. They would inevitably be reduced to the ordinary condition of apprentices, employed in discouraging tasks for one and even two years; that is to say, long enough to lose the better part of what they had learned at school. No account would be taken of their professional preparation except in establishments where the chief was exceptionally well disposed; and it is not wise to base a calculation upon exceptions.

The teaching of trades in the primary school would not be really profitable to the pupils unless they could remain there until the age when they were sufficiently developed physically and prepared professionally to enter at once as workmen into the shops. But it would be necessary to retain them at school three years longer, and for that purpose to quadruple, and even

quintuple the extent of the school buildings. It is much more simple and more rational to create establishments of a higher grade into which boys shall enter on leaving the primary school, and where for three years they will receive a technical instruction at the same time that they complete their elementary knowledge, and from which they will go with force and skill sufficient to enable them to exercise their trade properly. They will thus have escaped the injurious influences undergone by children who are placed in workshops too early.

These considerations cannot be weakened by the example of what has been done for several years at the primary municipal school *de la rue Tournefort*. There the pupils are not confined to elementary manual exercises. An attempt is made to give instruction in very different trades, but it can be done only upon a very small and insufficient scale; and, as boys cannot be retained there beyond their thirteenth year, they are neither expert enough nor well enough developed to be employed immediately in workshops outside unless in exceptional cases. Nevertheless, the experiment undertaken in this school is extremely interesting. It shows to what degree boys from ten to twelve or thirteen years can exhibit taste and skill in manual exercises without injury to their intellectual work. In fact, quite the contrary is true. For this reason, if no other, this school would deserve to be encouraged as a special type.

The question for the commission then is not to determine what it is possible to do in exceptional cases in a primary school, but to ascertain how the system could be made general and enable the pupils of all schools to acquire that complementary education, which is the object of this report. The problem is how to introduce generally into the primary schools those altogether elementary labors which every person ought to be capable of performing whatever his social position; labors which are the foundation of all trades, which serve to develop manual skill, and are in a multitude of cases a means of awakening ingenuity at the same time that they are a precious means of rendering service or of overcoming a difficulty. Moreover, these elementary labors require neither a great supply of tools nor extensive room. They can accordingly be taught in all common district (*communaux*) schools. The question no longer waits for a theoretical solution. It has been practically solved for several months in a certain number of municipal schools and has immediately given the most satisfactory results. The labors adopted as being most suitable are very simple carpentry and wood turning. Later, it will be possible, if it should seem desirable, to add working in iron or any other metal. For the present, and professionally, the manual exercises are voluntary on the part of the pupil, and are carried on outside of class hours. Children are not admitted to the shop until after they are ten years of age; and it is worth noting here that those who are of an age to be admitted show the greatest eagerness to attend, and labor with the most remarkable enthusiasm, giving in this way nearly three hours a day to this kind of instruction, beyond the regular class hours, and to the very great satisfaction of their friends. One part of the problem, however, remains to be solved: How could children from six to ten years of age take part in manual exercises without having to use tools for which they would not have strength and with which, besides, they might injure themselves? That is to say, how can the exercises

already begun in the infant school be continued in the primary school—certain instructive plays, certain manual exercises well adapted to the natural inclinations of the youngest age? The solution of this interesting part of the problem is at this moment being sought in schools already provided with tools. The pupils old enough to be admitted to the workshop there prepare the materials for instructive plays for their younger fellow pupils.

There will be plenty to do in this direction. The teachers will have to show as much active ingenuity as patient considerateness. They will need especially to abandon the habit of correcting the uneasiness of children by automatic exercises for the whole body. It is a convenience without doubt to have recourse to automatism, but the school is not made for the convenience of the teachers. It is made for the best development of the various faculties of the pupils, and automatic exercises, often repeated, are a complete abandonment of its true aim. The teachers, however, are very generally animated by the most active desire to do well. They will clearly understand and will zealously perform the duties which the new system of education imposes upon them. They will grow in value by the efforts they are forced to make and this will be a clear gain for the youth entrusted to their care.

M. le Préfet: The task of the reporter is still only half completed. It remains to point out the imperative necessity of making the complementary education, which has just been spoken of, beneficial to the whole body of the youthful generations. If it were merely a question of introducing manual training into the primary school, in order to prepare the children of the people for a life of labor from early youth, one might be content with the foregoing considerations and suggestions; but to work out and apply a system of education exclusively adapted to the children of the people (working classes), which should not be suitable to those of the middle class, would be going in direct opposition to the democratic spirit, and would perpetuate the moral and intellectual separation between these two great social elements. Still further, there is reason to hope that the day will soon come when the primary grade of instruction will no longer be given in the Lycées, and when children of every social condition will be required to begin their education on the benches of the primary school.

Not only does the democratic principle require this community of education, but a social interest of the first importance demands it. The mingling of the children of the middle classes with those of the working classes (*peuple*), will have the happiest results. It would be the most important means of nurturing sentiments of good-fellowship among youth of very diverse conditions, and will check at their source those dividing sentiments which have already produced deplorable effects and may produce still more deplorable ones. But aside from the great interest there would be in giving primary instruction in only one kind of schools, and, for children of every social position, it should be well borne in mind that the complement of education, which forms the object of this report, and which has been already provided in a certain number of schools, should be made to extend to the whole body of youth. For a long time, little attention has been paid, in education, to the physical being. It was with great difficulty that public opinion secured the introduction of gymnastic exercises. It seemed not to be understood that the intellectual, moral, and the physical capacities are closely conjoined in one

system; so closely conjoined that, if either remained neglected the others were prevented from exhibiting their full force. How, indeed, could the moral forces produce their effects without the aid of intelligence and of the arms? What could the intellect do in a multitude of cases without the aid of the hand? Yet, even to this day, education is conducted as if it were not true that the arm is the indispensable auxiliary of the intellect and the heart; as if the hand, the intellect, and the heart were disconnected, and, consequently, as if no attention need be paid to the cultivation of the three orders of faculties. Thence comes a defective education based upon a false principle; a kind of voluntary infirmity which renders so many people incapable of doing anything with their hands. And yet the cultivation of the physical capacities, joined to cultivation of the intelligence and the feelings, has never been so necessary as in our time. The present century is one of prodigious activity, of gigantic labors, of unheard of daring in the field of enterprise, of everything which demands intellectual vigor associated with physical force and manual skill. Moreover, society at the present time is preoccupied with the improvement of education for the new generations in order that they may have in full exercise their moral, physical, and intellectual forces. . . .

From a logical point of view the question is clear; from the moment when the solidarity of the three orders of faculty is admitted it is absolutely necessary to provide for their joint development. The natural tendencies of children point in the same direction as clearly as possible. From the time that the child is able to stand, and even before, he wishes to touch everything. He early endeavors to do something with his hands; he desires tools; he wishes to handle them long before he is able to use them; he needs at least a little shovel to work in the earth, a bucket to carry it; he plants imitation trees; he builds and then overthrows his buildings in order to build them again in another way or in another place. In this, most people see nothing except the child's way of keeping himself in motion, but such people having eyes see not, and having intelligence, do not understand. They do not see and understand that in these instinctive manifestations of the young being, the future worker reveals himself. In truth it is nature that speaks, proclaiming in the child the destiny of the man, and his duty, or at least a part of his duty, in life. Education should be conformed to this course of nature, universally and constantly expressed, or it rests upon false principles.

It is high time to understand the indications furnished by the instinct of children and to give as soon as possible satisfaction to their two-fold need of working with the hands and of knowing the reason of things; that is to say, it is time to bring about a veritable revolution in the manner of rearing youth. If one wishes to follow resolutely the course of nature and the clear indications furnished by the instinctive dispositions of children, if manual exercises are considered as essential, they should have a serious part in education commensurate with their importance. In the end, it will be found that it is possible to shorten the time of class work in order to give a sufficient amount of time to manual exercises; and that this will be done not only without injury to the intellectual development, but that, on the contrary, it will promote it. In the first place, manual exercises are not carried on without awakening the intelligence, and still further, it is doing violence to the active nature of the children to confine them three hours in succession, twice a day,

before the school desk. They submit, but with reluctance; they are subject to constraint; they are ill at ease physically and morally. They would certainly learn better in two hours if the third were given to manual exercises. It should be observed also, in order to obtain more time for the exercises of the workshop, that there is a tendency in primary education, as well as in secondary and higher, to overload the program of study more and more. It seems as if the aim were less to develop the intellectual capacity than to heap up knowledge upon knowledge in the head of the children at the risk of exhausting the intellectual force. This tendency is most injurious, but we hasten to say that already many important men, educational officials, have perceived that they were going by a false path, and are showing themselves disposed to make a change. Whenever the conviction shall become general that it is absolutely necessary at every stage to train the physical capacity, the manual faculties, from that day the program of studies will be necessarily rearranged. Ability to use the hands is hardly less important to the sons of the middle class than to those of the working class. Indeed, there are many learned professions which demand a certain manual skill on the part of their practitioners. It is required for surgeons, architects, civil engineers, engineering officers, artillery officers, naval officers. All of these need to know how to work. The same is true of inventors, who are so often prevented from profiting by their ingenuity because they cannot put their invention into tangible form. Even literary men themselves, and all men whose profession is purely intellectual, would be fortunate in many cases to find relaxation for the mind in manual exercises and in executing certain useful works. This is for all men a natural need. It must needs be satisfied, and the level of the general capacity will be made higher by so much.

To conclude, the complement of education, which is here considered, is desired by nature itself. It is desired by the general public sentiment, and required as a means of responding to the inventive and transforming genius of modern society; and, finally, it is required by the solidarity of the faculties of the human being. Let us add, that it will be impossible to point out any disadvantages in it, but that, on the contrary, it possesses nothing but advantages. (1—436—439)

SOURCE MATERIAL III, B

MANUAL TRAINING INSTRUCTION IN THE ELEMENTARY SCHOOLS OF PARIS

By A. July

Inspector of Manual Instruction

From *Pratt Institute Monthly*, April, 1898

Instruction in manual work appears in the list of obligatory matters enumerated in Article I of the law of March 28, 1882, at present in force throughout all French territory. The law defines this instruction as follows: "manual work and the use of the tools of the principal trades." The *rapporteur*, in order that there might be no misunderstanding as to the intention of the lawmaker, had indicated the character of manual work in the school as follows:

"We do not ask that the primary (elementary) school shall become a

trade school: we do not believe that a pupil should leave it to be a locksmith or a vinegrower, but we believe that scientific teaching should not rest in the domain of pure theory, and that practical applications to different industries should hold a large place in such teaching."

In the regulations which followed the promulgation of the law, and which constituted a commentary on it, it was recommended to the teacher, in respect to manual training, that he do not neglect manual training; that he do not neglect the education of the child's senses; and that he early develop those qualities ofadroitness and of agility, that promptness and certainty of movement which, valuable for all, are most especially needful for the pupils of the primary schools, who are destined, for the most part, to manual occupations.

If the principle laid down by the law of 1882 was new, the idea nevertheless went back to a decidedly early date.

In 1879, a commission was charged with the maturing of a plan of general organization. Its chairman, M. Corbon, demanded that the new instruction should be considered only as the necessary complement of a rational education, and that it should be limited "to those forms of work which are absolutely elementary, of which every individual should be capable, whatever his social condition; to those which form the basis of all trades, which are sufficient for the development of manual dexterity, and which require neither a large number of tools nor extensive ground-space."

From 1880 to 1886, workshops were installed in a hundred schools; the sessions for manual training were arranged for morning and evening, outside of the regular class hours.

In 1882, manual training was rendered obligatory; and from 1886, after the promulgation of our present organic law, the reform of the schedule permitted its return to the course of the regular classes, three hours a week being given to it.

The instruction was placed in charge of workingmen, the teacher attending only to the order of the class; there was no correlation between the workshop courses and the program of intellectual studies.

The series of models copied without even being previously drawn, formed a methodized *ensemble* of manipulations combined with a view to apprenticeship, but which led only imperfectly to the end desired. The children, repelled by work which was heavy and uninteresting, rarely went beyond the earlier numbers of each series; and the institutions could not maintain instruction entirely foreign to their program.

The necessity for a reform promptly became evident; a new commission was charged with the improvement of the program established in 1880, by combining manual work with the school studies and by extending the scope given to the instructors. This commission, which included MM. Salicis and R. Leblanc, between 1888 and 1890 worked out the program now in operation.

Manual work is there considered from the educator's point of view; it is certainly not to be thought of that the primary school shall prepare intending apprentices for their work in wood or in iron; even if this could be done, it would in any case render the course useful to only a small number. Moreover, the handling of tools exacts an expenditure of physical strength which too

young a child cannot meet; and apprenticeship at too early an age would run the risk of warping the development of the organization in the formative stage, or would lead to faulty manipulations which might be injurious to the future workman. It was therefore conceded that children should not be admitted to the workshops before the age of ten years.

With younger children, the work consists of exercises in folding and paper-cutting brought into very close relation with the scientific program, and having for their object the initiation of the pupils into the drawing and laying-out of the regular figures. These performances are a logical preparation for the labors of the workshop, which no one could attempt without a preliminary knowledge of drawing. This work can be done in the ordinary classroom, without a special equipment, and can be made to include all pupils.

PROGRAM OF EXERCISES IN THE ELEMENTARY SCHOOL
OF THE CITY OF PARIS

The exercises in manual work are divided into two categories, according as the school is or is not provided with a special shop for wood and metal-working.

Work Without a Shop. Folding and cutting of paper or of cards of different colors. This is the same in all the schools, with the children of the first three classes (first- and second-year elementary class, first-year intermediate class); that is to say, with children from seven to ten years of age.

In the schools where a workshop is opened, children are admitted to it on completing the second year of the intermediate course, or about the age of ten years. These schools are 123 in number.

Workshop Exercises. Work without a shop, as we have just defined it, fills but imperfectly the requirements sought. It is evidently fitted to accomplish the training of the eye; it furnishes an essential element in the scientific part of our primary curriculum. These are incontestable advantages which fully justify its introduction into our schools; but it cannot give those qualities of adroitness and agility, that dexterity and that suppleness of hand, which are useful to all, and particularly to the future artisan. It is only in the workshop that this manual education can be given.

The exercises have a double aim—physical and intellectual education. The manipulations are graded in such a manner that the motions, at first very simple, and involving only a few members—the hand, the arm—extend by degrees to the whole body, and lead to a coordination of complex movements so directed as to develop adroitness and certainty in motion—not dexterity, properly so-called, in the handling of certain tools. It is, so to speak, a rational gymnastic of address.

It is no less certain that the education of the eye is perfected in the workshop. It is the habit of exact measurements, the necessity of producing geometrical forms with prevision, the comparison of them with type-forms—the different squares, rules, models—which give to workmen the quickness and exactness of eye which could not be acquired to the same degree without training in a workshop.

In the school shop, manual work must in addition be related to the intellectual program. Thus, the exercise of making the model of an ornament or of a useful article is the development of a figured sketch made by the pupil;

it requires the making of geometrical outlines; and, during the working-out, it presents exact forms which lend themselves to the setting forth and the verification of the properties of ordinary figures. Is not the handling of drawing-implements, moreover, an excellent drill in practical geometry?

In fine, the end proposed is to develop both intelligence and adroitness, at the same time giving to the future apprentice knowledge which will later be of great service to him in the workshop.

Woodworking. (First year in the shop) The wood is distributed to the pupils already roughed out—that is, made of the proper thickness and width. Work is done at the beginning on a small board of poplar, ten centimeters in width and one in thickness.

The first exercises deal with the square and certain rosettes derived from it, and require only the manipulation of the light saw called a tenon saw, of the flat and half-round rasp, and of the file.

On small boards of beech, finished on the faces only, the use of the plane is begun, with the dressing of an edge. The use of the above-named tools is continued for the making of certain ordinary articles, such as a paper knife, a folder, etc.

Lastly, the execution of certain rosettes and stars, derived from an equilateral triangle and from a regular hexagon and octagon, leads to the use of the chisel.

Iron working. The material used is a wire of semicircular section, five millimeters in diameter, made of soft annealed steel. This wire is supple enough to be worked cold with a riveting hammer of 120 grams on a little anvil with two beaks (called a *bigorne*), and is sufficiently resisting to remain in the form which has been given to it. The aim of the work is to introduce the children to the use of the hammer; it enables one to take advantage of all that is educational in the trade of the smith (accuracy of stroke, sureness of hand) without presenting the dangers of forging iron.

The exercises consist of little *motifs* imitating the productions of the ornamental iron worker. Semicylindrical wire bends very easily, and two lengths of it are bound together by applying the flat sides, one upon the other, with a binder of semicylindrical wire three millimeters in diameter.

The only tools used are a riveting hammer of 120 grams weight, an anvil of two kilos, and small file one half round, one half smooth, for cutting the wire.

ADVANCED COURSE

(Corresponding to the last two years of an American grammar school)

Woodworking. The wood is distributed rough from the saw, and the pupils dress it themselves.

The objects produced the first year include no fitted pieces whose execution calls for a skill which could not be required of children from eleven to twelve years of age. There are ornamental *motifs*—panels, fretwork, interlaced designs, rosettes; or useful articles—tablets, prism-shaped or cylindrical stakes, penholders, etc.—all of which are intended to introduce the pupils progressively to the use of tools employed in woodworking.

Fitted pieces are not undertaken until the second year; they include the

execution of simple assembled work, with applications to the making of useful objects—square, bracket T-square, little bench, picture frame, etc.

Iron working. The work with wire is continued but with smooth sheet steel of one-half millimeter thickness. This material, laid flat on the anvil, is easily cut with a little chisel; the chipped edges are finished with a smooth file.

The curved parts are cut out of the flat by a chisel with rounded edge, called "carp's-tongue," and the chipped edges finished with a smooth file, either half-round or rattail. The branches of the rosettes are veined and repressed on lead, with a round-faced hammer or with punches of appropriate forms.

This work causes the hand to acquire suppleness, gives certainty to the hammer stroke, introduces to the use of the file, and brings the eye to seize on forms endowed with movement, approaching those obtained by clay modeling.

During the second year of the advanced course (*cours supérieur*), the children use the iron worker's tools, and are trained in various ordinary operations which belong to metalworking—dressing with the file, polishing, drilling, tapping, fitting, brazing, soldering in tin, etc.

The method employed in the work of the shop is the same as that of the cutting-out work. The pupils are furnished with a workshop notebook, in which they make their sketch of the object to be executed. A succinct statement is afterward dictated on the next step in the work. The pupils of the same section work together on the same task. When a new manipulation presents itself, or whenever the teacher judges it well to give a general explanation, he assembles all the little workers about him; his instructions are always simultaneous, and become individual only when a faulty position is to be rectified.

One danger is to be avoided in simultaneous instruction in manual work. Our little workers are some more and some less adroit; a step taken together is liable to retard the more skillful. To avoid this undesirable result, the teacher demands greater perfection in workmanship from those who can work faster. Moreover, each exercise may be supplemented by chamfers, chisel work, ornamentation of various kinds, which are permitted only when the fundamental processes have been properly performed. The experiments made since 1890 have shown that in general this method of procedure is preferable to individual instruction—that it is less burdensome to the teacher and more profitable for the child.

TEACHING FORCE

Work without a shop is placed in the hands of the teachers; that done in the workshop requires the collaboration of the teacher and a master-workman.

Even though there be no thought of training future craftsmen, it is not the less important that the hand be not spoiled by faulty manipulation. A vicious habit contracted early might have regrettable consequences for an ulterior apprenticeship; and it is therefore indispensable that the work be directed by a person of skill and practical experience. Moreover, the care of the tools and the preparation of material for work demand an amount of rough work which could not be exacted of a teacher. Nor would it be possible

without impropriety to intrust children to workmen without training as teachers; while on the other hand, as manual training in the workshop must be related to the courses of the classroom, it belongs to the teacher to give the theoretical explanations which connect the application made in the shop with the primary scientific studies. The master-workman, then, is in some sort the *préparateur* of the teacher.

ORGANIZATION

There are at present in the city of Paris 124 primary schools provided with woodworking shops, and in 36 of these schools, a metalworking shop has been opened. The service is shared among 62 joiners and 18 machinists. The time per week given by the pupils to manual work is two hours in the primary grades, and three in the grammar grades.

PREPARATION OF THE TEACHING FORCE

In order to insure the scientific carrying out of the curriculum which we have just analyzed, there have been established (in addition to courses of lectures given to the teachers) courses of normal instruction which have been pursued since 1891 by more than one third of the teaching force as an official duty. The master-workmen, who are recruited by means of public competitive examination, receive very precise pedagogical directions from the supervising body. They work exclusively for the schools, and therefore can devote themselves fully to the mission intrusted to them. (10—VI, 197–201)

SOURCE REFERENCES

1. *Report of the Commission on Industrial Education* made to the Legislature of Pennsylvania, 1891.
2. Lewis, William. *Manual Instruction in France and Switzerland*. Report to the Court of the University of Wales. Aberystwyth, 1896(?).
3. Leblanc, René. *L'Enseignement Manuel dans les Écoles du Degré Primaire*. Librairie Larousse, Paris. 1896(?).
4. Schoenhof, J. *Technical Education in France*. Government Printing Office, Washington, 1888.
5. *Eighth Annual Report of the Commissioner of Labor*. Washington, 1893.
6. Perry, Charles Copland. *Report on French Technical Education*. Issued by the Science and Art Department, England. London, 1898.
7. Bennett, Charles A. "Visiting Manual Training Schools in Europe." *Manual Training Magazine*, Peoria, 1910.
8. Laubier, D. and Bougueret, A. *Le Travail Manuel à l'École de la Rue Tournefort*. Paris, 1888.
9. Lavergne, F. *Les Écoles et les Œuvres Municipales d'Enseignement*. 1871–1900. Société Anonyme de Publications Périodiques. Paris, 1900.
10. July, A. "Manual Training Instruction in the Elementary Schools of Paris." *Pratt Institute Monthly*, April, 1898.
11. Salicis, A. *Manual Training in France*. Educational Monograph. New York College for the Training of Teachers, May, 1890.

CHAPTER IV

TRADE AND TECHNICAL EDUCATION IN FRANCE

28. **The Beginnings of a National Policy.** The same historical background that was essential to an understanding of the development of manual training in France (cf. 24) is equally important as an introduction to an understanding of the development of trade and technical schools in France, especially those under government auspices. In fact, the growth of trade and technical instruction which took place so rapidly after 1880 was a very natural continuation and further development of what was recorded in the first part of Chapter III as taking place before that date.

As early as 1871 Mr. Gérard, director of the Paris Academy, had said:

From whatever point of view one considers the different conditions of apprenticeship, they do not correspond with the needs of youth. The want of forethought in the parents, the indifference of the master, the impotence of the law, all betray the education of the apprentice. The development of commercial competition and progress in industrial technique are turned to his disadvantage. . . . It will be generally admitted that the workshop, which ought to develop all the powers of the boy, wears out his body before nature has completed its development in form and power; blunts the intelligence which the school has tried to awaken; shrivels up his heart and imagination, and destroys his spirit of work. Deplorable school of private morals! It robs the man in the apprentice, the citizen in the workman; and does not make even an efficient workman. (1—59)

The teaching of trades, which had been started by private initiative and in some cases carried forward in schools established and maintained by the communes or the departments, after the Paris Exposition of 1878, came to be regarded as a matter of such serious national concern that a general governmental policy was considered essential to continued industrial prosperity. It was then that there came into being a few national schools and the gradual establishment of a

policy in dealing with questions of trade and industrial education. In general, the early policy of the national government was "to provide facilities for giving a broad industrial training which combines a thorough course of scientific and technical study with enough practical work to render students expecting to enter the handicrafts or factory work familiar with the manual operations of the various trades." (2—705) The task of establishing schools for more intensive and restricted training in trade processes and in highly specialized branches of industrial work was, as a rule, left to local governments, private organizations, and individuals, although the government encouraged these efforts in various ways and in many cases assisted in their maintenance by granting annual subsidies. The liberality of the government in this respect is indicated by the fact that, while there were only 48 institutions receiving such financial aid in 1880 there were 292 in 1900. (2—705)

The second part of the report of the Corbon commission of 1879 (cf. 26) was prepared by Senator Tolain and dealt with apprenticeship and trade instruction. The reasons for recommending State action were given as: (1) the decline of apprenticeship and the subsequent abandonment of the former practice of giving technical instruction to young workers; (2) the increased division of labor, resulting in many specialities in the place of former trades; (3) the extensive replacing of handwork by machine work and the development of large factories; (4) the fact that many manufacturers had entirely abandoned the practice of taking apprentices; and (5) the competition of foreign manufacturers, particularly those in Germany, Belgium, and America. (3—440)

This report divided the various industries into two classes: (a) parent industries and (b) special industries. A parent industry was considered one that consisted of a group of closely related trades, as furniture making, including the work of the cabinetmaker, the upholsterer, the wood carver, the inlayer, the locksmith, etc. On the other hand, shoe-making or tailoring, for example, were looked upon as special industries. No provision in the report was made for training

apprentices for the special industries; but, for parent industries, it was proposed to establish manual apprenticeship or trade schools; and the system recommended was based on the idea that, by grouping trades in this way, the early part of the course, both theoretical and manual, could be the same for all students and that in that part of the course the natural aptitude of each student could be discovered, thus enabling the school to help the student in choosing the particular trade he ought to follow. The evident differentiation uppermost in the minds of the Commission was between ability to do accurate mechanical work, on the one hand, or work of an artistic nature on the other. In the words of the report, "Without departing from the principle already laid down, the Commission proposes to group together in the same apprentice school a certain number of trades; the program of the school, whilst giving the same instruction during the first year to all the apprentices, would, in the second year, enable them to apply themselves specially either to works of precision or to those requiring artistic taste." (3—441) (Source Material IVA)

For the City of Paris, the Commission recommended three such schools, one for the furniture industry, one for the building trades, and one for industries making various instruments of precision—optical, mathematical and scientific instruments, telegraphic apparatus, clocks, surgical instruments, and other small machinery. There was already in Paris one school of this type, *École Diderot*, for wood-working and metalworking trades, established in 1873, which had proved to be very successful. (3—442)

In reference to the special and more isolated trades, it was the opinion of the Commission "that manufacturers should themselves take the initiative." The report expressed satisfaction that in several industries the employers had not waited for its advice but had established workshops for apprentices, while others had organized classes to supplement the practical instruction of the workshop with theoretical instruction. The Commission suggested that in such cases, if certain specified conditions were met, it would be appro-

priate for a municipal council to come forward with a grant of public funds. (3—442)

29. **National Industrial Schools.** One of the results of the Corbon report was the law of May, 1880, creating a new order of schools of manual apprenticeship, or pre-vocational, or industrial schools (*écoles manuelles d'apprentissage*) under the dual control of the Minister of Public Instruction and the Minister of Agriculture and Commerce. These schools were intended to provide "general technical instruction and not an apprenticeship in any definite trade." They were "to develop in youths intended for manual trades the requisite dexterity and technical knowledge." (4—1) The law also provided for affiliating with these industrial schools the higher elementary or intermediate schools which offered courses or classes in shopwork and other technical instruction. (4—2) In this connection, it should be stated that the dual-control feature of this law was due to a compromise. It was proposed that a special grant be made to the Ministry of Agriculture and Commerce for the purpose of creating a complete system of elementary technical instruction that would provide a technical school in each Department. Opposition on the part of supporters of the Ministry of Public Instruction led to the compromise law providing dual control of the new schools. This led to irritating difficulties. Divergent interests, conflicts in methods of procedure, and differences in the ideals of ministers tended to make the law ineffective. (4—4)

Under the dual-control administration, however, one successful piece of work was accomplished: the establishment of the three national industrial schools (*écoles nationales professionnelles*) at Armentières, Voiron, and Vierzon. Concerning the scope of these schools, there were differences of opinion, but the agreement was ultimately reached that each should be "a national school of higher elementary and technical instruction intended to serve in preparation for apprenticeship." "All specialization in manual instruction should be avoided." (4—5) The character of the school at Vierzon was determined by the decree of July 1881. The

school was opened in 1887. It was intended to be a pattern for other schools that were to follow. In 1882, the year that manual training was made compulsory in the public elementary schools of France, the schools at Armentières and Voiron were provided for and the first of these was opened in 1887 and the second in 1886. Each of these national schools consisted of (1) an infant school for boys only from four to seven years of age, (2) an elementary school—seven to twelve years of age, and (3) a technical school of higher elementary or intermediate school grade. In the infant school, one hour a day was devoted to hand-work. This consisted of making flowers and other objects out of paper, cardboard, and cloth. (6—262) The instruction in the elementary school, as reported in 1891, was the same as given in the ordinary elementary schools, “with some modifications in the manual work” in view of the vocational purpose in the work to follow in the higher school. (5—72)

The program of the intermediate school included French and at least one other modern language, writing, general and French history; arithmetic, algebra, geometry, trigonometry, bookkeeping and accounts; geography, physics, chemistry, natural history; drawing, modeling, singing, gymnastics, and manual work. The latter included, for the first year, wood and metalwork two hours daily. During the second year three hours daily were spent in the workshops. Five hours a day were given to shopwork the first half of the third year and seven hours the second half. In this year, the shopwork included turning and toolmaking. (5—72—74) The amount and kind of shopwork, however, varied somewhat, depending upon community needs. For example, much attention was given to weaving at Armentières and Voiron and to the making of agricultural implements at Vierzon. Later, an agricultural department was added at Vierzon and Voiron. In 1898, a fourth school was added to this group by transforming a private institution at Nantes into a national trade school. But this one did not include the infant school and the elementary school. (3—727)

30. **The National System of Vocational Schools.** As would be expected from a study of their curricula, the national industrial schools did not fulfill the expectations of the men who devised the law of 1880. Graduates of these schools went into a great variety of occupations—many into banks and commercial pursuits; others into higher educational institutions. In the first few years, only about one half of them went into any kind of industrial occupation, and then not many of them to remain as workmen because they had received enough technical training to become foremen and superintendents. (6—265) The compromise system of administration had produced a compromise school and a compromise result—valuable, yet not entirely meeting the demands of either industry or commerce.

In 1892, a clause was inserted in the financial law which created schools of a new type under the direction of the Ministry of Commerce and Industry. These were to be known as schools of practice in commerce and industry. (*écoles pratiques de commerce ou d'industrie.*) The purpose of these schools was specifically to train clerks and workmen “whose services can be at once utilized in the counting room and the workshop.” They were to be vocational schools. The announcement sent out to schools by the Minister of Commerce and Industry a few months after the law was passed said:

The value of a general education, both for its own sake and as a necessary basis for technical knowledge, is, of course, incontestable. No one would desire to banish it from the *écoles pratiques* which will include some primary instruction, and into which no boy will be admitted who has not fulfilled the conditions imposed by the Compulsory Education Law of March 1882. On the other hand, it is essential that special provision should be made at the present time for the requirements of industry and commerce. The keenness of international competitions has revolutionized the conditions of trade. The wholesale use of machinery and the minute subdivision of labor has practically extinguished apprenticeship in the workshop. Yet, in view of the constant changes to which machinery is subject, it is evident that there never was a time when it was so requisite that workmen should possess scientific knowledge, and should be thoroughly versed in all the requirements of the workshop. It is the special aim of the *école pratique* to fill the void which now exists both in commerce and in industry. (4—7)

It was maintained that boys going into industry should "learn both the theory and practice of a trade with sufficient completeness to give their services an immediate market value," and that "if they are to acquire the degree of efficiency which will, after a short experience of a trade workshop, enable them to earn the wages of an ordinary workman, they must necessarily spend a large part of their time in the school workshop." From 25 to 30 hours a week in the workshop were considered necessary to accomplish this. (4—35)

The real significance of this law of 1892 was in the fact that it marked the successful introduction of the principle of trade teaching into the public-school system of France. (4—8) It was a second vital step in the establishment of a government policy concerning vocational schools.

Subjects	<i>Écoles Primaires Supérieures (Section Industrielle)</i>			<i>Écoles Nationales Professionnelles (Voiron)</i>				<i>Écoles Pratiques d'Industrie</i>		
	Years			Years				Years		
	I.	II.	III.	I.	II.	III.		I.	II.	III.
Workshops or manual work . . .	—	6	6	14	17 $\frac{1}{4}$	a	b	30	30	33
Arithmetic, Algebra, Geometry, Mechanics, etc.	—	3	3	5	6	4	10	3	3	4 $\frac{1}{2}$
Writing and Drawing of various kinds	—	5 $\frac{1}{2}$	5 $\frac{1}{2}$	6	6	6	10 $\frac{1}{2}$	6	6	6
Natural Science and History	—	3	3	4	4	4	—	1 $\frac{1}{2}$	4 $\frac{1}{2}$	3
Literary—Reading, Grammar, Composition, Geography, History, Languages.	—	5	5	9	8	6 $\frac{1}{2}$	7	6	6	1 $\frac{1}{2}$
Other subjects—Book-keeping, Technology, Singing, Gymnastics.	—	7 $\frac{1}{2}$	7 $\frac{1}{2}$	2	2 $\frac{1}{4}$	2	2 $\frac{1}{2}$	—	—	3
Hours per week	—	30	30	40	44	47	45	46 $\frac{1}{2}$	49 $\frac{1}{2}$	51

The comparative study of time allowances to the various major subjects in the industrial courses of the public intermediate schools, the national industrial schools, and the vocational schools in the accompanying table reveals a significant fact. In the public intermediate schools, only 30 hours a week were allowed for all subjects; while, in the practice schools, that amount of time was used for manual work alone.

This vocational school program was not obligatory in every detail, but it expressed an ideal and was intended to set a standard for this type of school when offering an industrial course.

Within five years, eighteen schools for boys giving industrial courses had come under the provisions of the law of 1892. Eight of these schools were also giving commercial courses, and three other schools for girls were giving both industrial and commercial courses. Among the most noted of these schools were those at Harve and Saint-Etienne for boys and the one at Marseille for girls. By 1902, France had thirty-four of these vocational schools. Their success was such that in 1900 the four national industrial schools were placed under the Ministry of Commerce and Industry, thus doing away with the system of joint control for these schools. (2—709)

31. **The Municipal Trade Schools of Paris.** The most complete working out of the ideals behind the law of 1892, establishing the national system of vocational schools, is found in the municipal trade schools of Paris. In fact, these schools (*écoles professionnelles*) furnished the ideals behind the law. In this, as in many other matters, the city of Paris led the nation. It was the success of the first of these schools, *École Diderot*, that was in the minds of the men who sought to formulate a national policy for industrial education in 1879 when they recommended the establishing of schools for parent industries, (cf. 28) and the continued success of these schools was an object lesson to the law makers of 1892. The municipal trade schools of Paris, then, are essentially *écoles pratiques d'industrie*, though designated by a different name. Quoting from Charles Copland Perry's report of

1898, "The principle which it (*École Diderot*) introduced in 1872 has, after more than twenty years of discussion and doubt, received official sanction by the institution of the *écoles pratiques d'industrie* as a new category of state schools." (4—21)

The *École Diderot* was established by resolution adopted by the municipal council on the 27th of May, 1872, and formally opened on the 6th of January, 1873. It was named for a celebrated French philosopher and writer of the eighteenth century. It is a school for the building and machine trades. It was located in a section of the city inhabited chiefly by mechanics and laborers. By November, 1873, there were 121 pupils in attendance. (2—785)

In the early days of the school it had to meet the hostility of the labor unions and the indifference of employers, but in a few years the reputation of the school had become such that "graduates experienced no difficulty in securing good positions in establishments of the first rank." Meanwhile the enlargement of the school plant to accommodate 300 students became necessary, also an increase in funds for its support. (2—785)

Students were admitted by competitive examination. They were required to be graduates of elementary schools and not less than thirteen nor more than seventeen years of age. The course of instruction covered three years—approximately half of the time being given to theoretical subjects and drawing and the other half to shopwork. The study of the technology of tools, materials, machines, and processes of manufacture was included among the theoretical subjects. In 1909 the shopwork included (a) carpentry, (b) patternmaking, (c) plumbing, (d) blacksmithing, (e) coppersmithing, (f) locksmithing, (g) electrical construction, (h) machine construction, and (i) the making of instruments of precision. In general, the work done by students was of superior quality.

In this, as in other French vocational schools, an effort was made during the first part of the course to determine in which of the available group of trades a boy should spend the

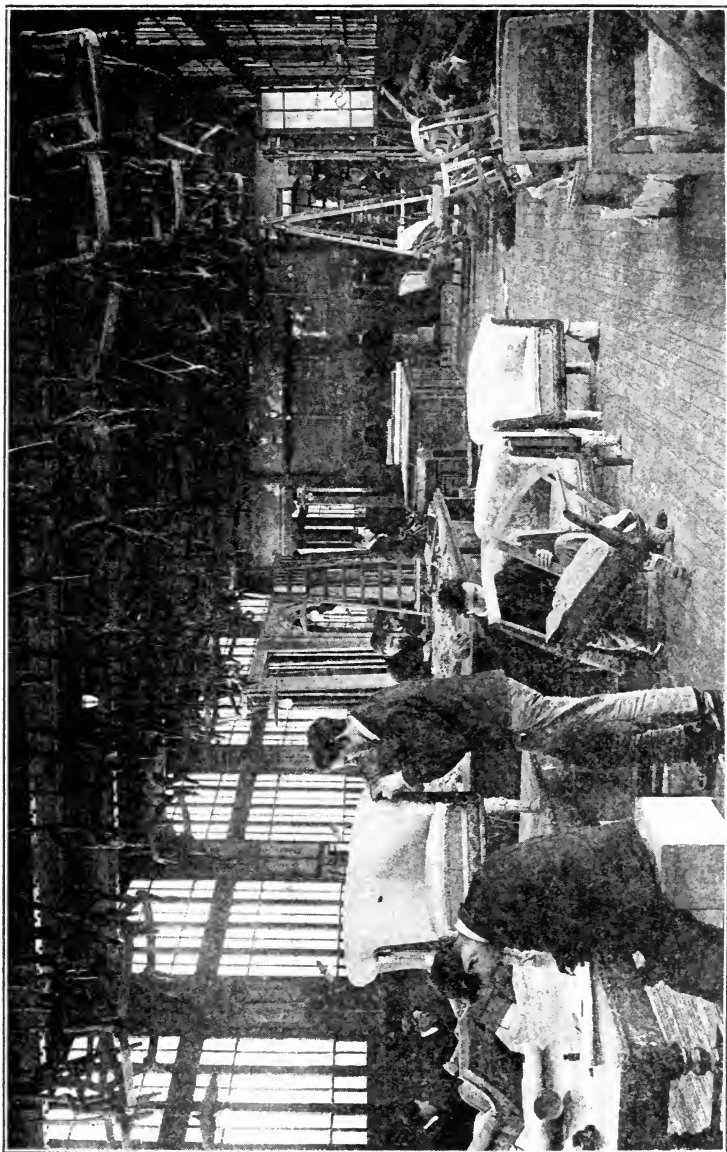

FIG. 65. UPHOLSTERY SHOP IN *École Boulle*, Paris

major part of his time while in school. To accomplish this all boys were rotated through the different shops during a part or all of the first year in order to determine for which trade they were best adapted. In the early days of the school, the boys passed through all the shops in this try-out course; later the number of shops was limited to those related to each other in industry. This plan was said to be more economical of the boy's time. A teaching device attributed to this school was to place a first-year student between a second-year student on one side and a third-year student on the other. He was expected to profit from observation of the work of his more experienced companions. (2—786)

While the shopwork in this school included both exercise pieces and completed useful machines, or other objects, all of the work done was practical. In fact, by means of an active advisory committee upon which expert artisans were in the majority, the shop teaching was kept in close touch with the standard demands of the trades represented in the school shops.

Similar, in general plan, was the famous *École Bouille*, the municipal trade school for the furniture industry, named in honor of a celebrated French cabinet designer and maker during the reign of Louis XIV. This school was opened in 1886 in quite limited quarters but, in 1895, it was moved into a new building constructed especially for its use. The purpose of the school was to train workmen capable of "maintaining in the manufacture of artistic furniture, the traditions of taste and general superiority by which the industries of Paris are distinguished." (4—16)

Instruction in the following trades was offered from its beginning: (a) cabinetmaking, (b) upholstery, (c) wood carving, and (d) the construction of sofas and chairs, Fig. 65. After moving into its new building in 1895, metalworking was added. In 1914, the courses offered and the number of students in each course were reported as follows: sculpturing wood and stone, 36; furniture making, 60; metal repoussé work, 36; upholstery and tapestry, 45; machinists,

24; engraving and die sinking, 15; jewelry work, 5; metal turning and spinning, 16. (8—41)

The regular course covered three years, but students were allowed to remain two years more for specialized study. On account of the fact that the work in this school gave so much emphasis to art and design, students entering the school needed to be especially strong in drawing. During the

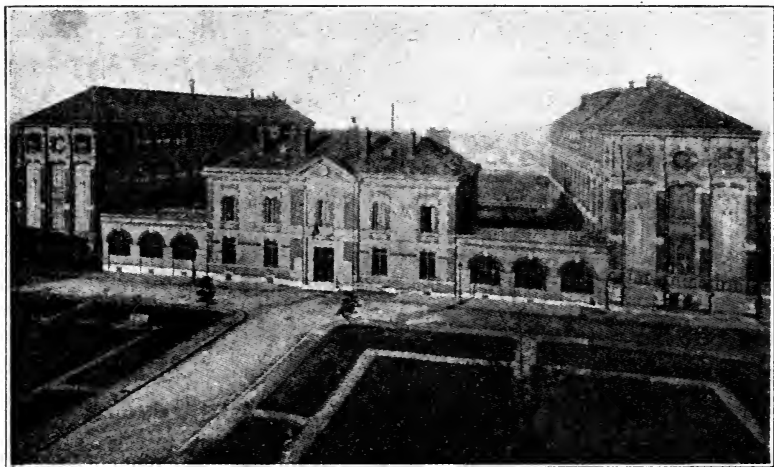

FIG. 66. *École Estienne*, PARIS

course, also, much attention was given to such subjects as clay modeling, water-color painting, designing, and the history of art. Other subjects in the course included applied science, mathematics, bookkeeping, the French language, and two foreign languages, English and German. (8—42)

The actual trade training is based on exercise work and general products in each trade of the highest degree of art in workmanship. Some of the work is of such excellence that it is sold by the city at prices higher than the market, the proceeds reverting to the city treasury. (8—42)

The *École Estienne* is the municipal school for the printing and bookmaking industry. It was named for a famous family of printers dating back to 1470. One member of the family, Robert Estienne, was royal printer to Francis I. Like the *École Boulle*, this school began in temporary quarters and, in

1895, moved into an excellent building constructed especially for its use. Fig. 66. The conditions of admission were essentially the same as for entrance to the other municipal schools of this class. The theoretical studies also were similar to those in the other schools of this type, consisting of language, history, science, and mathematics, common to all the schools, and history of art, history of bookmaking, drawing, and design with special reference to the bookmaking industry. The practical instruction included, in 1909, book-binding, gilding, type making, stereotyping, electrotyping, typography, linotype operating, presswork, lithography, woodengraving, photoengraving, copper-plate engraving, etching, and printing from etched plates. The course of instruction covered four years. In general, the theoretical instruction was given in the forenoon and the practical instruction in the afternoon. The school hours were from 8 A.M. to 6 P.M.

As might be expected, the City of Paris did not confine its instruction in the art trades to those connected with furniture and bookmaking. In the year 1882, the municipal council decided to take over two private schools of art which had been receiving a subsidy from the city, and to combine them into a public school of industrial art. (2—756) In his report to the British Government in 1898, Charles Copland Perry said:

It was not the intention of the decree referred to, or of the municipality, to create two schools independent of one another, both teaching, in an equal degree, the application of art to industry. The schools were, on the contrary, to be closely connected, being respectively preparatory and complementary to one another. Whilst the *École Germain-Pilon* is an "*école municipale préparatoire de dessin pratique*," the *École Bernard-Palissy* is an "*école spéciale municipale d'application des beaux-arts à l'industrie*." The *École Germain-Pilon* is an "*école d'application de dessin*," teaching the principles of drawing in their relation to industrial art as a whole, but without reference to any special branch of it, and without any practical work in workshop or studio. The *École Bernard-Palissy*, on the other hand, is an "*école d'application*" in a more literal sense, intended for the purpose of forming *ouvriers artistes* for four different trades, and having four special *ateliers* for painting in porcelain, sculpture in wood, stone, and marble, theatrical and domestic decoration, and lastly for designing in stuffs. While there still continues to be an essential distinction in the aims and the practical training of the two schools, time has shown the original

scheme of their interdependence to be impracticable. It was found, as might have been expected, that the parents of the boys could not afford a course of study extending over six years. In order to counteract the loss of pupils which the new system entailed on the *École Bernard-Palissy*, leave was granted to the latter to take boys who had not passed through the *École Germain-Pilon*, and to add a fourth year to its course, the first year now becoming a stage preliminary to admission into the workshops. This new arrangement, which virtually renders the two schools separate and independent, though their connection still nominally exists, has proved beneficial to both of them. Besides saving the *École Bernard-Palissy* from gradual extinction, it has given a great impulse to the development of the *École Germain-Pilon* under the experienced management of its present director. Since 1889, the year of his appointment, important alterations have been introduced, tending at once to make the teaching more scientific and to place the school in closer touch with local industries. Special attention is now given to geometrical drawing which, in the second and third years, includes perspective and the projection of shadows. The syllabus also includes decoration as applied to architecture, water color, the history of furniture and of the chief objects of art connected with it, the history of art, modeling, analysis of style, decorative composition and anatomy. (4—14)

The *École Germain-Pilon* became a boy's school for the intensive study of design and modeling preparatory to entering the art industries. The course consisted of three years of work. Entrance was by competitive examination after completing the work of the elementary schools. In 1909, only one sixth of the applicants were able to gain admission. At that time, an outstanding characteristic of the work of this school was its emphasis on geometric drawing, mechanical perspective, and the freehand drawing of details of architectural ornament. The actual designing was done in the third year. (9—268)

The *École Bernard-Palissy*, named for a very celebrated French potter and enameler of the sixteenth century, had for its special aim the training of skilled artisans in several art industries. In 1900 these were classified as (1) decorative painters, (2) designers of textiles, (3) sculptors, and (4) potters. (9—271)

The schools above mentioned are the oldest and best known among the municipal trade schools for boys in the City of Paris. These five have been especially mentioned in order to make still clearer the type of institution that resulted from the report of 1879 and the laws of 1880 and

1892. There are several corresponding schools for girls. By 1900 there were thirteen schools of this type in Paris.

32. **National Schools of Trades and Industries.** For the purposes of this chapter, there is no need of presenting a classification of French schools for industrial education that reveals all possible differences in scope and method and means of support; but, in order to give the schools already mentioned their proper setting in the national system, it is necessary to make reference to a few of the schools for higher technical education under the administration of the Ministry of Commerce and Industry. The Central School of Trades and Industries (*École Centrale des Arts et Manufactures*), at Paris, founded in 1829, trains engineers of the highest grade for various branches of industry and for public service. (6—295) National schools of mines are located at Paris and Saint-Etienne. And the school that antedates them all is the School for Roads and Bridges (*École des Ponts et Chaussées*)¹ founded in 1747.

In a class slightly below these in grade are four great national schools of trades and industries (*Écoles nationales d'arts et métiers*). Generally speaking, these schools have outgrown their titles because they have become schools for engineers, draftsmen, and superintendents.

The first of these grew out of a trade school started by the Duke of La Rochefoucault-Liancourt in 1788.² In 1799 it was made a State school and taken to Compiègne. In 1803 it was reorganized and in 1806, owing to the increase in the number of students, it was removed to Châlons-sur-Marne. (7—I, 271) During the next hundred years this school, which started to train workmen in a few trades, gradually raised its standards until it was turning out mechanical engineers. This was possible because, after 1832, the age limit was increased to fifteen and admission was by competitive examination. Several times since then the age limit and the standard of the examinations have been

¹Bennett, Charles Alpheus. *History of Manual and Industrial Education up to 1870*, p. 345.

²Ibid., p. 276

raised. The number of boys applying for admission has been in excess of the number that could be admitted. In 1909, only one out of five or six applicants could be taken. The graduates of the school obtained very desirable positions. This was due quite largely to the fact that the curriculum of the school presented a satisfactory balance of theoretical and practical subjects. The daily program of the school was as follows:

Morning study—6:00 to 7:30

School—8:00 to 9:30

Shopwork—9:30 to 12:00

School—1:30 to 3:00

Shopwork—3:00 to 5:30

Evening Study—6:00 to 8:00

The school received only boarding students. The experiment of admitting day students was tried and found unsatisfactory. The number was limited to 300. From the above daily program, it will be seen that five hours a day were given to shopwork. This continued for three years. The school subjects were arranged as follows:

	<i>First year</i>	<i>Second year</i>	<i>Third year</i>
Monday	Mathematics Sketching	Study Drawing	Economic History Drawing
Tuesday	Physics Drawing	Mathematics Drawing	Mechanics Sketching
Wednesday	Literature Drawing	Mathematics Drawing	Electricity Metallurgy
Thursday	Mathematics Drawing	Chemistry Technology	Mechanics Drawing
Friday	Mathematics Drawing	Mathematics Sketching	Electricity Drawing
Saturday	Physics Technology	Geography Drawing	Mechanics Drawing

The simplicity and intensity of this three-year program of study is apparent. Before entering the course, students have received their general education. When they reach this school, they are ready to specialize and to work hard. Of the eighty graduates in 1909 forty passed an examination and were licensed by the State as mechanical engineers.

The large shop building, Fig. 67, is of saw-tooth roof

construction. This is made clear by the interior view of the woodworking shop, Fig. 68. This is 40 ft. by 120 ft. These illustrations merely suggest the general character of the shops. They do not give an adequate idea of their size (the machine shop is 180 ft. by 120 ft.) or of the high standard of workmanship maintained in them. The course consists in the construction of machines, engine lathes for example,

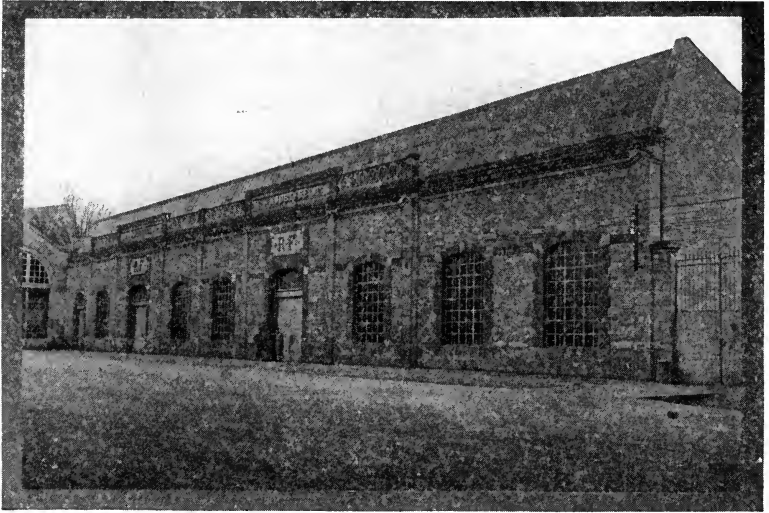

FIG. 67. SHOP BUILDING, NATIONAL SCHOOL OF TRADES AND INDUSTRIES, CHÂLONS-SUR-MARNE

and similar practical pieces of work, such as are done in industrial establishments. (2—743)

In 1804, a second national school of this type was opened at Beaupréau; but, in 1815, was moved to Angers, where it occupied the buildings of a former abbey. (7—I, 272) In 1843, it became evident that the two schools at Châlons and Angers could no longer meet the needs of industry for the type of graduate being sent out, and a third school was opened at Aix in what was formerly a convent. A fourth school, at Lille, was decided upon in 1881, but the doors were not open for instruction until 1900 when a new building for its use was completed. (7—I, 272)

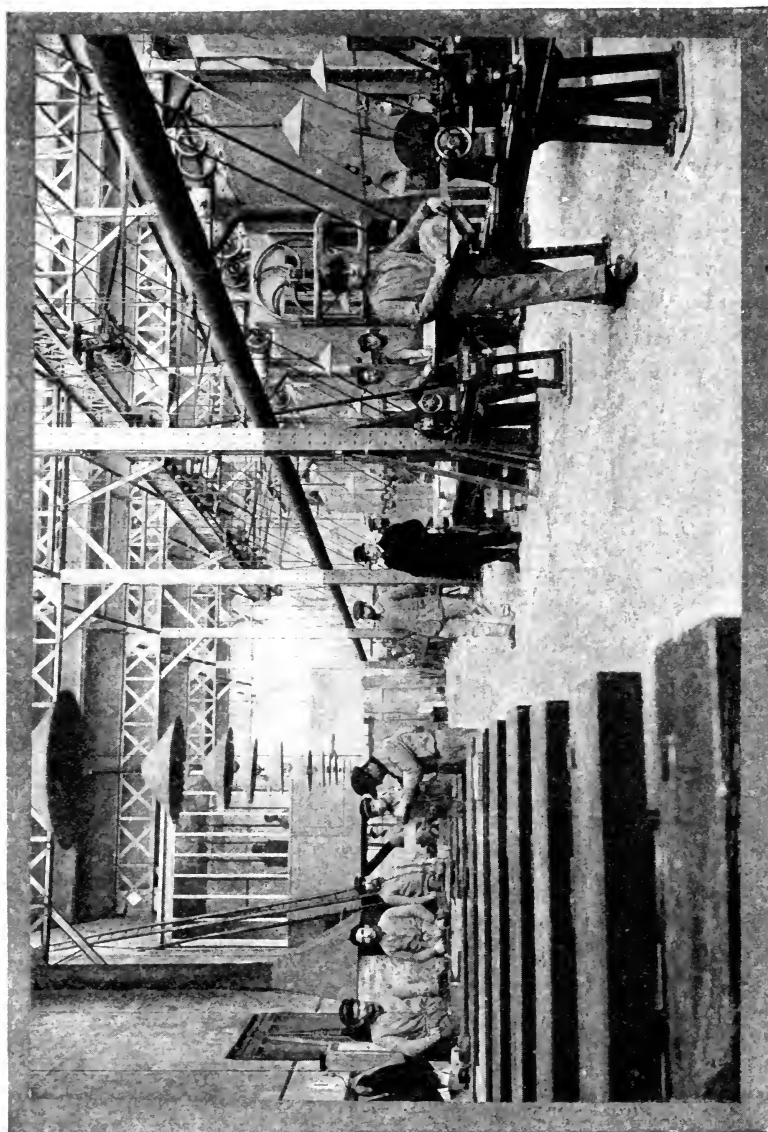

FIG. 68. WOODWORKING SHOP, NATIONAL SCHOOL OF TRADES AND INDUSTRIES, CHALONS-SUR-MARNE

This school has a department devoted to spinning and weaving in which students who have completed the course of instruction of the National School of Trades and Industries may devote an extra year to the textile industry.

33. Evening Schools. According to the British *Report of the Royal Commission* of 1884, the evening school instruction was then "one of the most striking features" of the educational system of France. The report states that "the subjects of instruction are of the most varied character, including modern languages, social science, physical science, biology, mathematics, applied science, astronomy, etc." Lectures and classwork were maintained by (1) the state, (2) the municipalities, (3) associations for private individuals. (10—I, 29) First to be mentioned among the institutions of the first group was the National Conservatory of Trades and Industries (*Conservatoire National des Arts et Métiers*) at Paris. This was founded in 1794. It was originally an industrial museum. Since 1819, it has been a school as well as a museum and has become famous especially because it is a great popular center of free evening instruction in industrial science. (6—296)

Two long-established organizations in Paris, the Polytechnic Association and the Philotechnic Association, give extensive courses of free lectures. The municipal trade schools do the same, and what is true of Paris is true to a lesser degree in other cities and towns. This is true to such an extent that it was observed by the Royal Commission that "the walls of the public buildings of Paris, as well as those of every French town which the Commissioners visited, were largely placarded with the announcements of evening lectures and classes, both for men and women." (10—I, 29) "City authorities, chambers of commerce, trade syndicates, and innumerable private societies give liberal support to technical schools and to evening and Sunday classes maintained in the interest of the working people, and offering either free tuition or requiring only small fees. No other country equals France in this respect." (11—11)

But, up to the opening of the World War, no effective

effort had been put forth to establish compulsory continuation schools. France had been the leader in the movement for vocational education. Every ambitious youth with good health could find an opportunity to acquire a practical education, but no youth was required to do so.

SOURCE MATERIAL IV, A

A SYSTEM OF APPRENTICESHIP SCHOOLS

By Senator Tolain

From Report to the Prefect of the Seine, 1879

In the first place, we were enabled to establish the fact that the various industries carried on in Paris may be divided into two great categories, viz: parent industries and special industries. It is certain, for instance, that, for working in wood and iron, a systematic education, both theoretical and practical, would give to a lad leaving a municipal apprenticeship school, such as the school on the *Boulevard de la Villette (École Diderot)*, the opportunity of following several trades and specialties; whilst, on the other hand, workmen in such important industries in the clothing trades, as tailors, shoemakers, hatters, etc., are confined to their own respective special branches.

Now it is more particularly in the parent industries, comprising various trades or specialties, having numerous points of resemblance, the work in which is of a similar character, and renders necessary to a great extent the same class of tools, that the system of apprenticeship is gradually disappearing; whilst employers are powerless to remedy the evil, however sincere may be their desire to do so. For these great industries, the only means of raising the standard of technical knowledge is the establishment of apprenticeship schools.

With these facts before us, a difficulty, however, still remained to be overcome. So long as hand labor, or speaking more accurately, the handling of the principal tools, forms no part of the education given in elementary schools, the apprenticeship schools will, in a great measure, be recruited in a haphazard way; since no opportunity will have been afforded for discovering the natural aptitudes of the pupils and determining their future vocations. Thus the education, however well organized, will not give such results as might otherwise reasonably be expected.

Without such preparation, it is impossible to discover whether the pupil is specially fitted for work requiring precision or taste, for trades necessitating mathematical knowledge or artistic feeling. This difficulty is destined to be overcome by degrees, in proportion as manual work becomes extended in the workshops annexed to elementary schools (and, by this means, we shall certainly be able to shorten the term of apprenticeship by one year). This difficulty, however, must be encountered at the beginning, and may give rise, in some minds, to doubts as to the real value of the education to be obtained in apprenticeship schools.

Without departing from the principle already laid down, the Commission proposes to group together in the same apprenticeship school a certain number of trades; the program of the school, whilst giving the same instruction during the first year to all the apprentices, would, in the second year, enable them to apply themselves specially either to works of precision or to those requiring artistic taste.

Inspired with this idea, the Commission proposes, by way of example, to establish an apprenticeship school for the furniture trades in the Faubourg St. Antoine, which would produce workers in wood who, according to their

natural aptitudes, would take up either the trade of a carpenter, a cabinet-maker, upholsterer, wood carver, inlayer, etc.; and workers in iron, who would become locksmiths, men skilled in metalwork for cabinetmakers and artistic lock makers. This example we consider sufficient to indicate the object to be aimed at with regard to each large branch of Parisian industry, viz: The grouping together of trades, which at the commencement of the apprenticeship, would require the same theoretical and manual instruction, and would permit of the distribution, by successive selections, of the apprentices in accordance with their aptitudes amongst the trades which involve more especially the knowledge of science or of art. Such is the system which the Commission proposes to adopt for the present industries.

It remained to determine what should be the conditions of admission to the new establishment. It was unanimously resolved that the admission should be absolutely free. A question then arose concerning the necessary qualification. Two plans were proposed. The first was that only those pupils should be admitted to the schools who held a certificate of primary studies; the second only required the student to pass a special examination of a very elementary character.

Is it, indeed, certain, asked the partisans of the examination plan, that the certificate can be regarded as a guarantee of capacity for the exercise of a handicraft? Assuredly not; all the faculties do not follow the same general groove. Although there may be some so constituted that they can do nothing without having first mastered the reasons for their actions, there are many, in fact by far the greater proportion, who should begin by practice and not by theory. This is especially true in matters of education, where we often proceed from sensations to thoughts, from particular facts to general laws, to return later from the rule to its application.

To require the certificate of primary studies would be to limit the number of competitors, and to reserve these new schools for the children of the less needy classes, for those whose parents have been able to keep them at the elementary schools until they obtained their certificate.

All men, however, who had specially interested themselves in the question of elementary education were unanimous in declaring the beneficial results arising from the system of certificates. If the certificate were not made obligatory for admission into the apprenticeship schools, competent judges feared that the spirit of emulation would be weakened. That this distinction is a powerful stimulus to exertion is proved by the fact that the number of certificates distributed yearly is always increasing. These reasons appeared conclusive, and the obligatory production of the certificate was adopted by the commission. (3—440—442)

SOURCE REFERENCES

1. Cooley, Edwin G. *Vocational Education in Europe*. Report to the Chicago Commercial Club, 1912.
2. *Trade and Technical Education*. Seventeenth Annual Report of the Commissioner of Labor, Washington, 1902.
3. *Report of the Commission on Industrial Education Made to the Legislature of Pennsylvania*, 1891.

4. Perry, Charles Copland. *Report on French Technical Education* issued by the Science and Art Department, London, 1898.
5. Teegan, Thomas Henry. *Technical, Industrial and Commercial Education in France*. Simpkin, Marshall & Co. London, 1891.
6. *Eighth Annual Report of the Commissioner of Labor*, Washington, 1892.
7. *L'Enseignement Technique en France*. Published in connection with the Exposition of 1900, Paris.
8. Glynn, Frank L. *Some Trade Schools in Europe*. Bulletin, U. S. Bureau of Education, Washington, 1914.
9. Lavergue, F. *Les Écoles et Les Œuvres Municipales d'Enseignement, 1871-1900*, Paris, 1900.
10. *Second Report of the Royal Commissioners on Technical Instruction*. Eyre and Spottiswoode, London, 1884.
11. Smith, Anna Tolman. *Demand for Vocational Education in the Countries at War*. U. S. Bureau of Education Bulletin, 1917, No. 36.

CHAPTER V

THE DEVELOPMENT OF MANUAL TRAINING IN GERMANY

34. **Manual Training and German Pedagogy.** One often hears the statement that manual training grew out of German pedagogy. In general, this is true; yet the manual-training movement, as such, in Germany received its first impulse from Denmark and Sweden. In Germany, as in the north countries, manual training, or educational sloyd, was a confluence of three streams of ideas. The first of these was economic, embodied in domestic industries; the second was social, as represented in the elementary public school; the third was pedagogic, exemplified in the Russian system of tool instruction on the one hand and the Swedish sloyd of Salomon on the other—one emphasizing class instruction and the other individual instruction, but both based on a pedagogical analysis of tool processes. As has been previously stated, Salomon received the fundamental idea of his educational sloyd from Cygnaeus (cf. 15) and Cygnaeus obtained his from the writings of Froebel, and Froebel was a student of Pestalozzi. By this process, manual training can be traced back to Central Europe, except for the one vital spark, namely, adequate analysis of processes.

We know that the manual-training work of the 80's in Germany was not a direct development of the practices of the kindergarten. (1—83) On the other hand, we know that the idea of handwork as a means in education had persisted in Germany among the followers of Pestalozzi, especially in industrial reform schools and institutions for poor and neglected children. Some followers of Herbart, also, had contributed to this end. Among these were Ernst Barth and his assistant, W. Niederley, who included practical instruction in handwork in their preparatory school in Leipsic. They regarded it "not simply as a preparation for the training for a life work, but as the best form of object teaching as

well." Therefore, in all grades of their preparatory school, handwork was "carried on in connection with the other branches of instruction." (2—43) To these should be added Friedrich Karl Biederman (1812—1901) publicist, historian, and professor at the University of Leipsic, whose book, *Erziehung zur Arbeit* (Education for Labor), published in 1852, and in revised edition in 1883, exerted a wide influence. He vigorously attacked some of the practices of the elementary schools and substantiated his claims with statistics. For example, he said that "purely mental exertion impedes healthy bodily development" and he gave statistics to prove it. He stated that the school instruction of that time corresponded with neither the true aim of public-school education "nor with the laws that directly relate to the nature of the child." (3—80) He earnestly advocated more practical instruction in the schools. "Practical and physical work," he said, "is a demand of human nature," especially in the young.

Since practical work is consistent with the nature of youth, there is no particular need of awakening an interest by artificial or compulsory means. Pedagogy itself will accomplish through practical instruction that which it conceives as its first duty; namely, to secure by investigation a correct knowledge of the true characteristics of its pupils.

Individuality presupposes a distinct self-activity, and can never be the result of receptivity alone. Every teacher has known boys who were remarkable for their dullness while at school, and who, when put in other surroundings, became active and useful, while some of the so-called excellent pupils grew to be lazy and unprincipled men. (3—81)

Another strong advocate of the manual element in public elementary education was Dr. Erasmus Schwab, director of the *Gymnasium* at Vienna, and "creator of the school garden." In 1873, he advocated the school workshop as a vital part of the elementary school. One of his statements was, "The most important pedagogical problem of our time is the introduction of work as an educative element in the organization of the *Volksschule*. It cannot otherwise fulfill its duty of educating the people, a task which becomes every day more difficult." (2—50)

By such statements as these, the minds of certain teachers

and officials were prepared for a new movement which received its first impulse from Denmark.

35. The Beginning of the Manual-Training Movement in Germany. The efforts of Clauson-Kaas to promote domestic industry in Denmark became known in Northern Germany about the middle of the seventies, and he was invited to give a lecture in Berlin. As a result of this, a society for the promotion of industrial work in the home was established in 1876. This society sent a Berlin teacher to take a course in the school established by Clauson-Kaas in Copenhagen. When he returned, he started a boy's work-school where "fret-saw work, inlaying, wood carving, carpentry, and brushmaking" were taught. (1—70)

In 1879, Clauson-Kaas delivered an address before the educators of Northwest Germany that resulted in a petition to the Government of Hanover for a course for training teachers of manual work in the province of Hanover. Consequently, a short course with Clauson-Kaas as teacher was opened at Emden in the extreme west of Germany on the sixth day of September, 1880. Sixty-three teachers took this course. (2—52) The subjects taught were "carpentry, fret-saw work, inlaying, cardboard work, and bookbinding, basket making, brush making, and plaiting in straw." (1—72) In Bremen, A. Lammers, through his magazine *Nordwest* and also his lectures, became an active promoter of domestic industry. (2—52)

Earlier in the same year, 1880, Clauson-Kaas had been invited to Eastern Germany to take a journey through the poverty-stricken districts of Silesia and make recommendations concerning domestic industries. About the same time, Emil von Schenckendorff, who had been chiefly instrumental in getting Clauson-Kaas to come to Silesia, with the cooperation of local officials at Görlitz, sent a petition to the Prussian Government recommending that a committee be sent to Denmark and Sweden to study the work schools in those countries. The Government granted the petition; von Schenckendorff was made the head of the committee. On their return, they reported that "no methodical and

well-organized system of instruction in manual work existed in Denmark"; that what few courses did exist were not taught by educators, and that their aim was merely the economic aim of home industries. They did, however, find real educational handwork being done in Sweden. In von Schenckendorff's report he said, "So far as I am able to ascertain, a definite and exact system of teaching is nowhere to be found; but the Swedish institutions, especially those at Nääs, already show an approximation to such a system." (1—73)

Meanwhile forces were in action in Saxony which were destined to set the standard for manual training in Germany. In 1879, at a meeting of the Leipsic Society for Public Welfare, a committee was appointed whose report resulted in the founding of the Leipsic Boys Workshop the following year. Work was begun in several rooms in a large school building, the boys being taught by master carpenters, bookbinders, locksmiths, and sculptors. (4—VII, 67)

The leading spirit in establishing this workshop was Dr. Waldemar Goetze (1843—1898), Fig. 69, of the high school in Leipsic, and he continued to be the leader of the manual-training movement in Germany until his death in 1898. Dr. Goetze was born in Dresden in 1843. His father kept a private school and his mother wished him to become a teacher. However, he wanted to follow in the footsteps of his brother, who was a machine builder. After one year as an apprentice, he went to the high school to prepare for the Polytechnic, to which he was admitted in 1859. Later, losing his opportunity to continue his apprenticeship, he changed his plans and was admitted to the University of Leipsic where, in his pedagogical studies, he came under the influence of Professor Ziller. But what gave special direction to his thoughts on education was his study of Biederman's *Erziehung zur Arbeit* (Education for Labor). (4—VII, 67)

Following an invitation from the Society for Public Welfare to prepare a paper on the pedagogical aspects of instruction in manual work, Dr. Goetze wrote *Die Ergänzung des Schulunterrichts durch Praktische Beschäftigung* (The

Completion of the Instruction of the School by Means of Practical Activity). (2—53) This paper, published in 1880, made clear the fact that in Leipsic, at least, the leaders in the new movement were not carried away with the economic advantages of instruction in handwork, but were basing their claims on its general educational value.



FIG. 69. WALDEMAR GOETZE

36. **The German Association for Boy's Handwork.** In Saxony especially, there was much enthusiasm for the new educational handwork, and the question arose how to coordinate the varied efforts into one common movement. On the invitation of von Schenckendorff, a conference was therefore held in Berlin on June 13, 1881. Professor Biedermann of Leipsic was made chairman. The result was the formation of the German Central Committee for Instruction in Manual

Dexterity and Home Industry. On June 3, 1882, the Central Committee met at Leipsic in connection with an extensive exhibition of work done in school shops. Exhibits came from Switzerland, Sweden, and many parts of Germany. The different branches of work represented "afforded a highly instructive picture of the various efforts which had been made." They gave proof of the strength of the efforts to reform education. "The work done at the Leipsic Boy's Workshop assisted materially in showing the different views of the subject taken by experts in education. The exhibits were divided into two classes. In one class, they were arranged in four divisions according to the material used—paper, wood, metal, clay. In the other, the work was divided according to the various branches of school teaching illustrated, without regard to the material employed." In reporting this exhibition, one of the German educational papers said, "In examining the work the spectator is at once impressed with the striking progress which the Danish method has made in the hands of the Leipsic teachers. One sees at a glance that *nothing alien* to the school has here been introduced but rather that the work is the direct outcome of the school; for every exhibit shows close relationship with the lives of the young and with the objects of school instruction." (1—74) But Dr. Goetze considered that the most important feature of this notable exhibit was the collection of working models sent by Salomon of Nääs, Sweden. (1—74)

In the summer of 1882, Dresden and Leipsic united in conducting a summer course for teachers at Dresden under the direction of Clauson-Kaas. Sixty-three candidates applied for admission and among them several distinguished men. This course differed from the one at Emden two years before in the fact that the number of kinds of work had been reduced through the process of adaptation to school purposes.

In October, 1883, the German Central Committee met again at Leipsic and decided that the training of teachers was the most effective means of promoting the cause. Later, committee meetings were held at Osnabrück in 1884, at

Görlitz in 1885, at Stuttgart in 1886, at Magdeburg in 1887, at Munich in 1888, at Hamburg in 1889, at Strassburg in 1890, and at Frankfort in 1892. (1—75) The Stuttgart meeting in 1886 marked a most important step forward for the manual-training movement in Germany. At that meet-



FIG. 70. TRAINING COLLEGE FOR TEACHERS, LEIPSIK

ing the Committee evolved into a permanent organization, *Der deutsche Verein für Knabenhandarbeit* (The German Association for Boy's Handwork). The first resolution passed by the new organization was to establish a training college for teachers at Leipsic. (1—76) Dr. Waldemar Goetze was made director of the college.

The Leipsic Boy's Workshop was placed at the disposal of the new college, thus definitely fixing the German center for the training of teachers at Leipsic. Teachers now began coming to Leipsic from all parts of Germany and from foreign countries. The instruction at first was confined to

the summer vacation period. From a single four-weeks' course from the middle of July to the middle of August, the work was expanded in 1887 to two such courses—one in July and the other in August. In 1889, a course was added at Easter and in 1890 an autumn course also. A new building for the training college was provided in 1896, Fig. 70.

37. The Leipsic Method. By this time, it was clear to the leaders of this movement that the type of manual training that was to prevail in Germany must be purely pedagogic in character. The money-earning considerations of the Danish work must be left out of consideration and a system developed that would be in harmony with German school ideals and practice. German manual training must be in the service of the German schools. This, then, was the fundamental aim of Dr. Goetze and his associates in developing what came to be known as the Leipsic method. As might be expected with such an aim and the background of German experiments in elementary education, the German manual-training system must take into consideration all the grades above the kindergarten and not merely the two or three upper grades of the elementary school. It did not, however, include the handwork for girls because sewing, knitting, darning, crocheting, and the like had long been a recognized part of elementary education for girls in Germany. (1—81)

One of the first essentials in the Leipsic method was to have the manual instruction given by trained teachers of other school subjects and not by artisans, although the teachers were to receive their special training in the manual work from expert artisans. This plan seemed reasonable because the teachers of boys in the schools were usually men and it was thought that by taking short summer courses they could acquire sufficient knowledge and skill to teach the boys paper and cardboard work, clay modeling, simple wood-work, metalwork, and even the more advanced bench wood-working. To give instruction to the boys, only such teachers were wanted as comprehended the entire scheme of general

education, of which the manual training was to become an integral part. In discussing the nature of the problems to be worked out by the boys Dr. Goetze pointed out that some advocates of manual training excluded all objects of utility; others would prefer useful objects. Some would have pupils make only objects useful in the home; others would insist that they be useful in the boy's school life or play. Some would place first emphasis on technical skill, while others maintained that such skill is not the main purpose in the manual work. Dr. Goetze said:

We certainly decide in favor of objects of utility, executed with technical correctness in a graduated, methodical order, *without excluding* preliminary exercises, which, indeed, are necessary for perfect work. . . . It matters little what objects are preferred. We must only insist upon choosing them from the boy's sphere of interest. We must also see that they are given in proper methodical sequence, according to the capacity of the learner, and are such as shall tend to develop it. If these conditions are fulfilled, objects for home use, or for children's games, are just as serviceable as those employed for intuitive instruction in physics, geography, or mathematics. (1—93)

Again he said:

We must be on our guard not to confound the interest which grownup people take in these things with that of children. Experience shows that boys work with the same pleasure at objects taken from school life as they do at those for home use. The point is to avoid setting work which they cannot comprehend, and to enter the circle of their ideas. The pleasure of seeing misconceptions born of word teaching cleared up by the contemplation of real things and by personal experience, and the happiness of being able to follow instruction with more intelligent understanding, are as great as the satisfaction of making objects for daily use. (1—94)

In contrast with the Herbartian purpose of manual instruction in the schools, which was that it exist for the benefit of the other branches of instruction, Dr. Goetze accepted the Froebellian viewpoint, which gives manual work an independent place of its own, parallel to mathematics or science. Concerning this Dr. Goetze wrote:

It is well known that many schoolmasters desire the tasks to be drawn from school instruction only, for the sake of connecting manual training with other branches of school instruction. They take an interest in manual training only so long as it goes hand in hand with other subjects, and so long as, through it, children realize practically what they have learned in natural history, geography, or physics. This leads to the question, whether manual training is

to be admitted only on account of the service it renders to other branches of education, or whether, by virtue of its peculiar educative influence, an independent position is to be assigned to it in the system of education.

We side with those who take the latter view. Manual training can neither do its own work nor be an efficient auxiliary to other subjects unless it be methodically organized on an independent footing. Unless manual training is to become mere amateur bungling, it cannot possibly depart from the natural method of proceeding from the easy to the difficult. (1—95)

None the less, manual training should prove a valuable ally to other branches of education, provided always that its application to them has been preceded by methodical instruction in the use of simple tools. (1—96)

Concerning the question of class instruction as opposed to individual instruction, Dr. Goetze took the middle ground. He looked upon individual instruction alone as merely an imitation of the apprentice system of instruction and that could not possibly be introduced into large schools. On the other hand, he did not believe in mass instruction of the military type. He recognized that the nature of the work required free and easy intercourse in the workshop, yet he considered it necessary to give instruction to a large number of pupils at one time. "The preliminary theoretical teaching naturally bears the character of class instruction. The materials, the tools and their use, have to be discussed; the tasks must be explained by question and answer. Afterwards the individual faculty of the pupil must have its rights." In order to keep the more rapid pupils fully and profitably employed between periods of class instruction, he would use supplementary exercises, or utilize the rapid boys as monitors to assist the slower members of the class. In large classes where "compelled by circumstances to instruct boys of different ages and unequal talents," he would organize the class into groups, placing those of about the same proficiency in a group to be taught together. In this way, he would approach class instruction. (1—99)

38. Leipsic a Center of Influence. The German Association for Boys' Handwork became the most positive influence for manual training in Germany not only because it established and maintained the training college at Leipsic, but also because it published a magazine, *Blätter für Knabenhandarbeit*. This publication began in 1886 and, after

twenty-five years of valuable service, in 1911, changed its form and its name to *die Arbeitsschule*. Accompanying this change went the announcement of an enlarged scope for the publication. The new aim was to give consideration to all worthy efforts which place self-activity and the creative efforts of the child at the center of the work of education.

Both the work of training teachers and the magazine were under the inspiring direction of Dr. Goetze until his death in 1898. Then an immediate effort was made to secure a successor who would carry forward the work of the Association in the same spirit and emphasize the same ideals. This resulted in the appointment of Dr. Alwin Pabst in 1899. Dr. Pabst had been a successful teacher of mathematics and physics and an enthusiastic promoter of manual training in a training college for teachers.

The work of developing courses of instruction begun by Dr. Goetze was continued by Dr. Pabst and published from time to time. Among those quite characteristic of Leipsic was the course in paper and cardboard work by Dr. Pabst, published in 1903, under the title *Normallehrgang für den Papparbeits-Unterricht*. It was a course involving the fundamental processes of paper-box making and some of those common in bookbinding. Fig. 71 shows samples of students' work in this subject. Fig. 72 suggests the character of the woodworking done in 1905, and Fig. 73 certain problems in metalwork and experimental apparatus for physics. Fig. 74 is a typical plate in *Lehrgang für die Hobelbankarbeit*, which represents the Leipsic course in woodworking in 1909. In this new course, considerable attention is given to design.

While the influence of the German Association and of the training college at Leipsic were very great, it must not be inferred that all German cities adopted the Leipsic course or even the Leipsic principles; neither should it be inferred that manual training was generally adopted in the elementary school of Germany during the period of the efforts of Dr. Goetze and Dr. Pabst. Although, as previously stated (cf. 34), manual training is said to have grown out of German pedagogy, it did not receive a cordial welcome at the hands

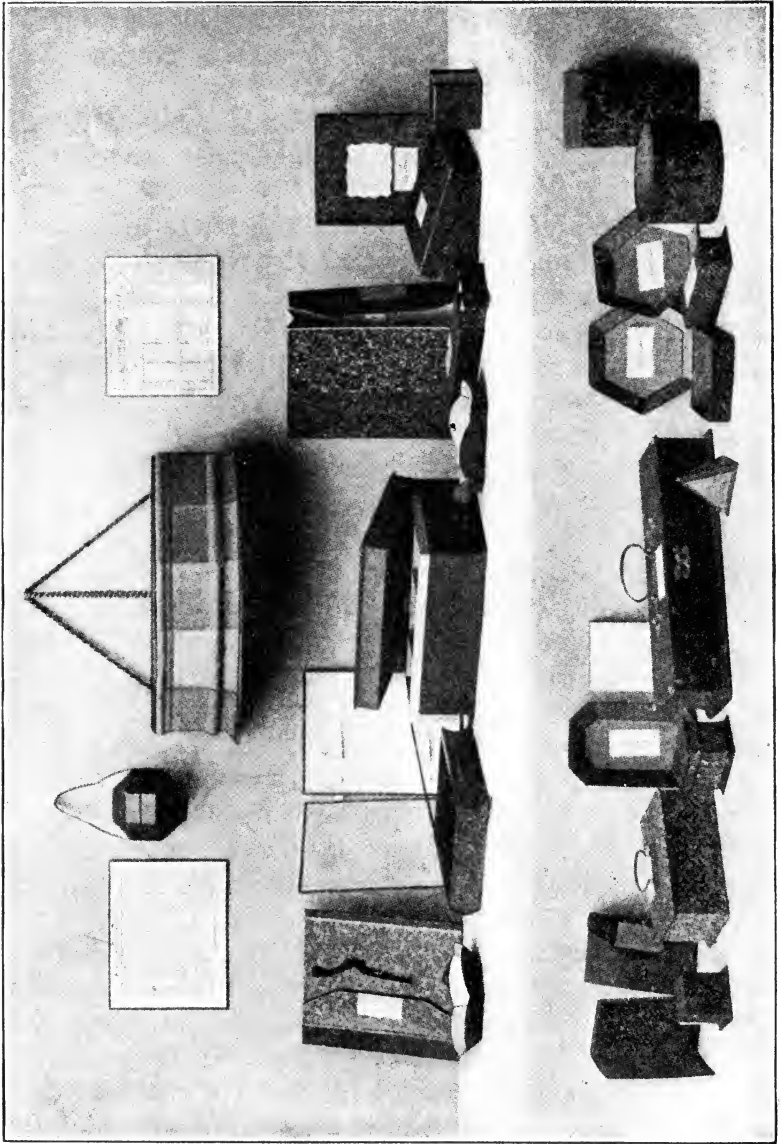

FIG. 71. LEIPSIK WORK IN PAPER-BOX MAKING AND BOOKBINDING

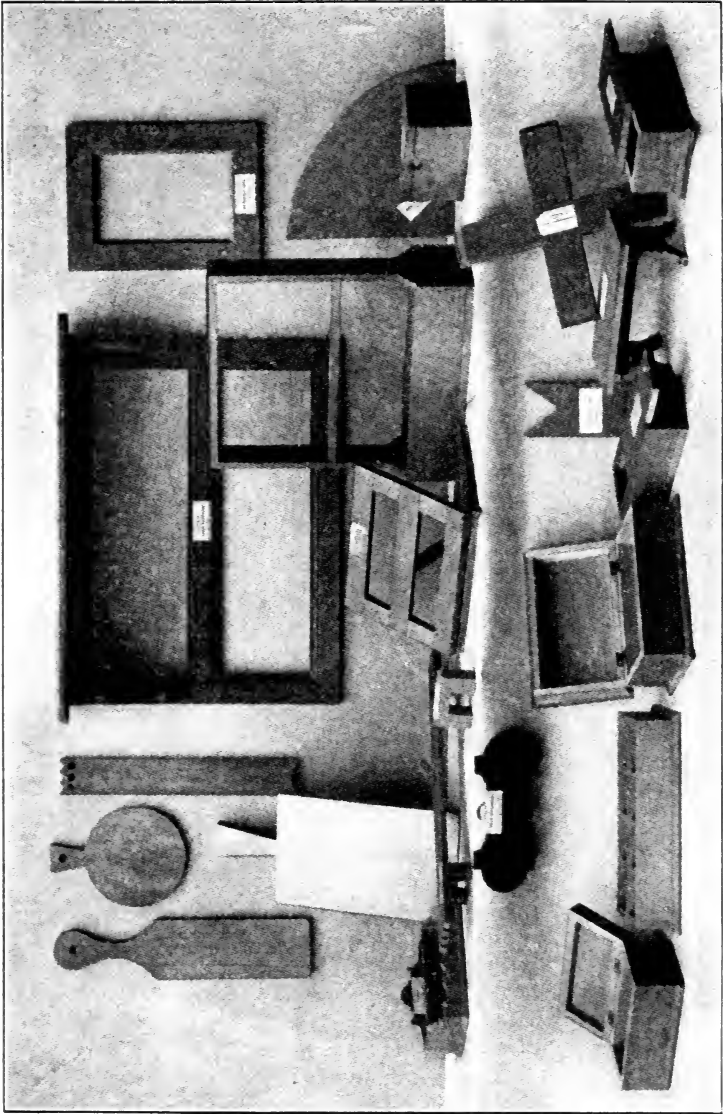

FIG. 72. THE LEIPSIK TYPE OF WOODWORKING MODELS

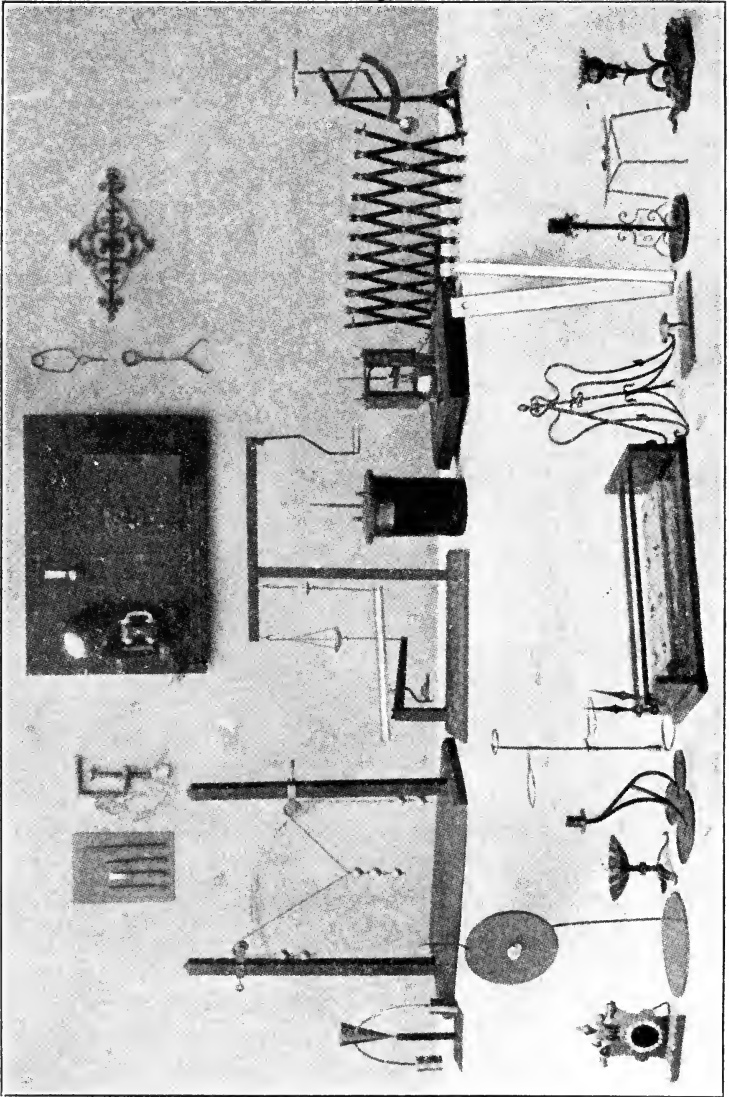

FIG. 73. LEIPSIK METALWORK AND EXPERIMENTAL APPARATUS

Tafel XIV.

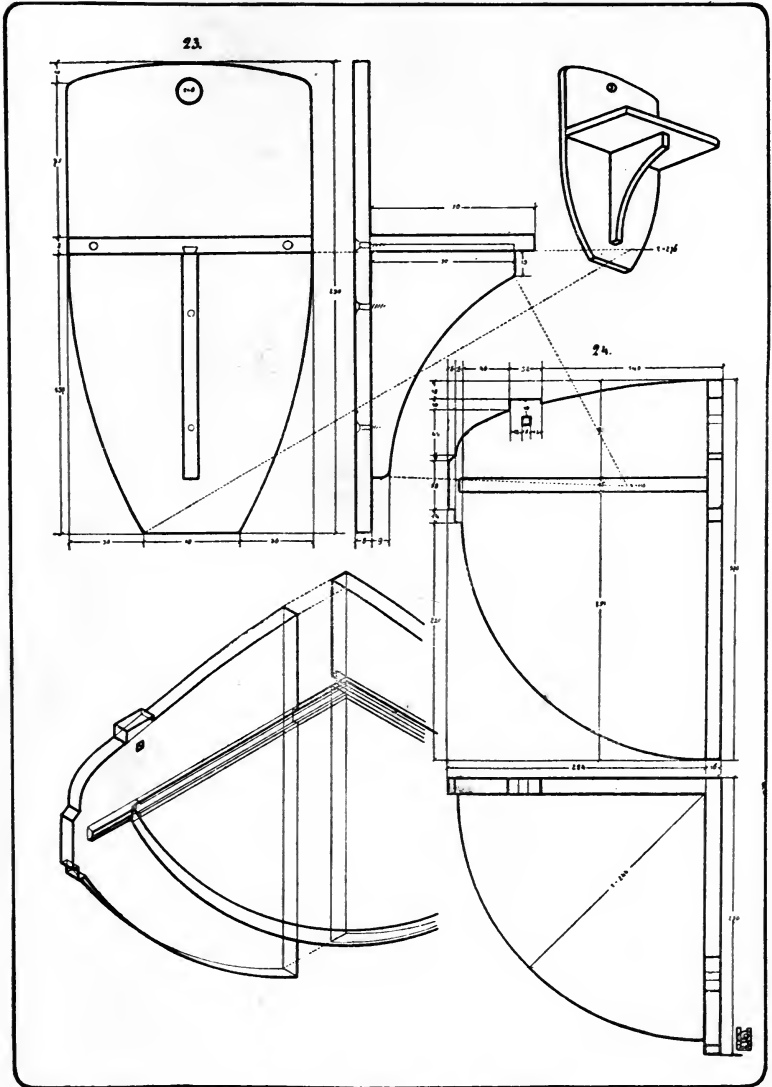

FIG. 74. TYPICAL DRAWING IN THE LEIPSIK WOODWORKING COURSE IN 1909

of the German schoolmasters. Even as late as 1909, there were only a few cities in all Germany where manual training was given an important place in the curriculum of public elementary schools. Such manual-training work as was allowed was usually done outside the regular school hours.

39. Manual Training in Munich. The City of Munich was a notable exception, not because the manual-training work came into the schools earlier or more rapidly than in some other cities; but because, when it did come in, it was given the central position among the subjects in the curriculum for the eighth grade. No place was given to shopwork below this grade, but in all the lower grades, including the seventh, construction work was encouraged involving (1) observation, (2) understanding, (3) drawing, and (4) making.

The program of development began in 1896. In that year, Dr. Georg Kerschensteiner, superintendent of public schools, succeeded in making instruction in cooking a required subject in the eighth grade of all girls' schools, and in making this work the center around which all the chemical, physical, physiological, and mathematical instruction for these girls was organized. A few years later, school gardens were provided, the kitchen gardens being entrusted to the girls of the eighth grade. Then aquaria, aviaries, and caterpillar and plant boxes were sent to the schools and "every year more than 10,000 bulbs were distributed among the third and fourth grades to be cultivated in the schools." In the year 1900, workshops for wood and metal were connected with all the eighth-grade classes for boys, and six hours of obligatory instruction were given in them each week. This new work provided the material for drawing and "for instruction in mechanics, geometry, and arithmetic." (6—XXXI, 282) Then came the climax of his effort when physics and chemistry were made required subjects for four hours a week in the eighth grade.

The extent to which this comprehensive program of reform affected the work of the eighth grade is indicated by the programs of studies in one of the elementary schools in Munich in 1909.

For boys—	
Religion	2 hours a week
German Language	2
Reading and Literature	3
History	2
Practical Mathematics	
including Bookkeeping	4
Mensuration of Solids	2
Natural Science (a) Theory	2
(b) Laboratory, Physics	2
Chemistry	2
Handwork: Woodworking and	
Metalworking, each a half year	4
Drawing	5
Gymnastics	2
	—
Total	32

For girls (who are in classes separate from the boys)	
Religion	2 hours a week
Reading and Literature	3
German Language	3
Domestic Economy: (a) Theory	4
(b) Practice	4
Drawing	2
Singing	1
Gymnastics	2
Needlework	4
	—
Total	25

It is significant that, in this finishing year of the elementary school, such emphasis was placed on practical mathematics, laboratory work in science, drawing, and manual training for the boys—in all 21 hours out of 32—and on domestic economy, needlework, and drawing for girls—in all 14 hours out of the 25. It is evident that the studies were selected with reference to a vital correlation, and with full recognition of the interests and natural development of the children, keeping in mind probable future occupation. This emphasis on the practical subjects, however, was not given to the courses of instruction in the grades below the eighth.

Another fact of importance in regard to the Munich work in manual training was that the problems given to the pupils were not useful articles but abstract exercises—pieces

of large dimensions quite suggestive of the early exercises of the Russian course Figs. 75 and 76. The organized artisans of the city did not approve the Leipsic system, involving the making of useful articles and the employment

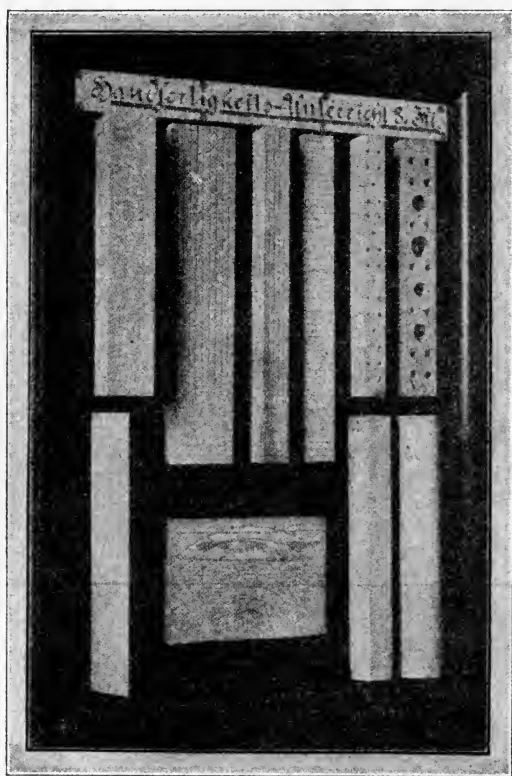

FIG. 75. FIRST WOODWORKING EXERCISES, MUNICH

of the regular grade teachers to give instruction in shopwork. In the Munich course, therefore, the purpose was to teach fundamental processes. The course of exercises was the same as was taught in the *Gewerbschule*, a school of secondary grade, and pupils of the eighth grade who completed the course satisfactorily were given credit in the *Gewerbschule*. (7—33)

Accompanying the instruction in tool processes was much

related technical instruction. In woodworking, it included wood as a raw material, its growth and structure, chemical by-products, influence of moisture, drying and preserving, uses of wood in industry, native and foreign varieties of

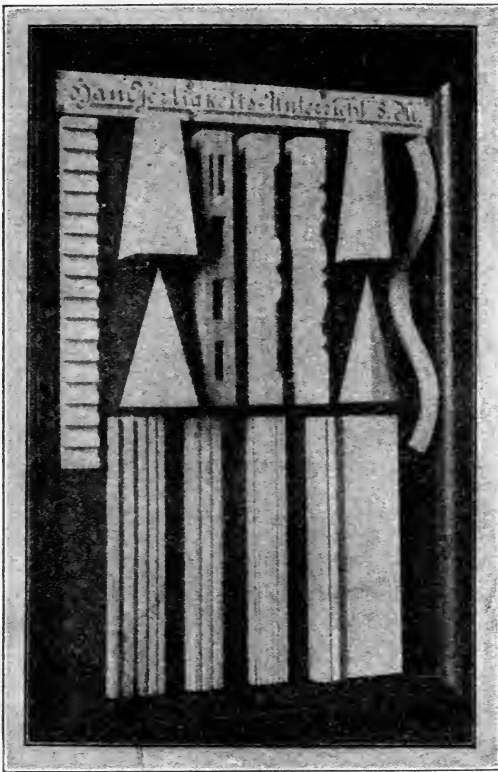

FIG. 76. ADVANCED WOODWORKING EXERCISES, MUNICH

wood and their special applications for industrial purposes, the enemies of wood, the chemical and technical processes of finishing wood, etc. In metalworking, it included mining, the blast furnace, products of the blast furnace, different kinds of iron and steel, the most important metals used in industry, alloys, iron as a commercial product, tools used in metalworking, problems of finishing and preserving metals, etc. (7—33)

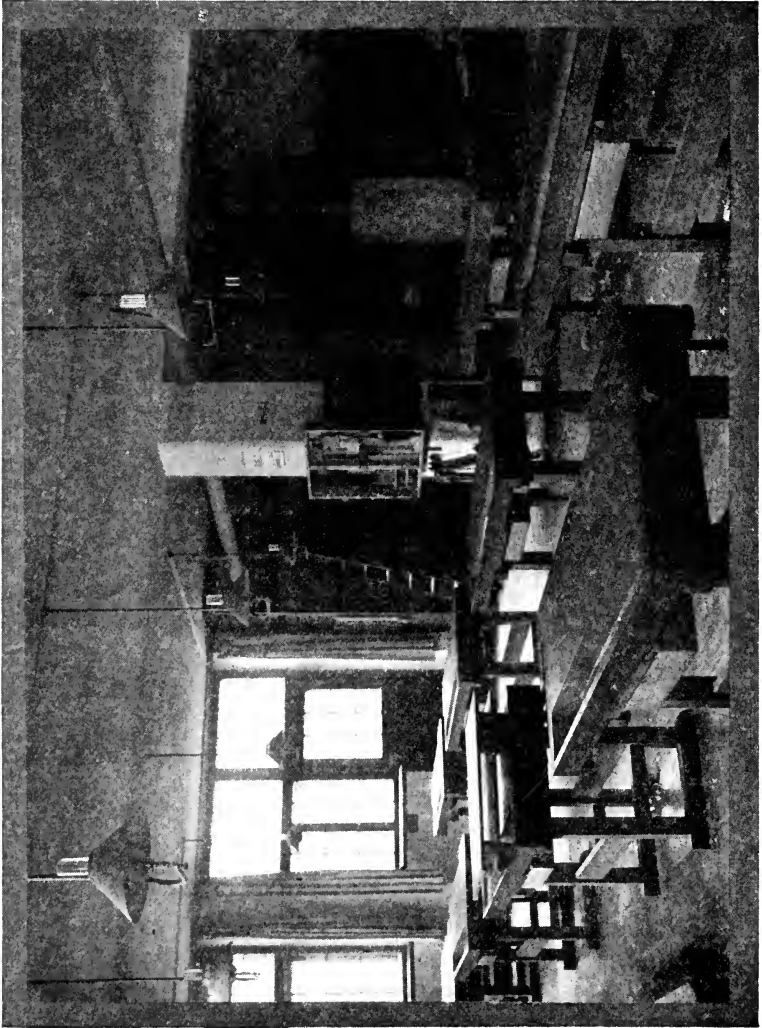

FIG. 77. WOODWORKING SHOP, FLURSTRASSE PUBLIC SCHOOL, MUNICH

The shopwork instruction in Munich was given by an expert craftsman. He was first selected by a carefully prepared test in practical work, in drawing, in mathematics, and in the technology of his craft. Then he must work in the schools of Munich for a year without salary, during which time he must attend courses in drawing and technical instruction and, in order to go through the curriculum of the eighth grade, in drawing and shopwork. He must, also, attend classes in pedagogy. If he passed another thorough examination, he might receive his appointment. (7—34) In the Munich system, shops were equipped for sixteen pupils. A class of thirty-two pupils in other subjects would be divided into two sections for shopwork. Fig. 77 shows the woodworking shop in the Flurstrasse School in 1909. The tools were kept in small cupboards—one for each bench—at as convenient points in the room as possible. Connected with this shop was a small but well-stocked museum for use in giving the technical instruction connected with the course in woodworking. Fig. 78 shows the interior of the well-appointed metalworking shop in the same school.

It now becomes evident that in several important respects the manual-training system of Munich was contrary to that in Leipsic, which was generally regarded as the typical German system. The pupils in Munich did not make useful objects, whereas in Leipsic they did; in Munich, much more technical instruction was given in connection with the shopwork, and the shopwork furnished much data for instruction in mathematics, science, and drawing; in Munich the teacher was a craftsman who had served a kind of teaching apprenticeship for a year; while in Leipsic, the instruction, except to teachers, was given by the regular grade teachers who had taken a short course in shopwork.

During the period from 1870 to the World War, other German cities developed manual-training courses of their own, but most of them accepted the Leipsic principles as the foundation of their scheme of work. Mannheim, for example, beginning as early as 1895 with cardboard work, and adding woodworking in 1899, metalworking in 1902, and clay

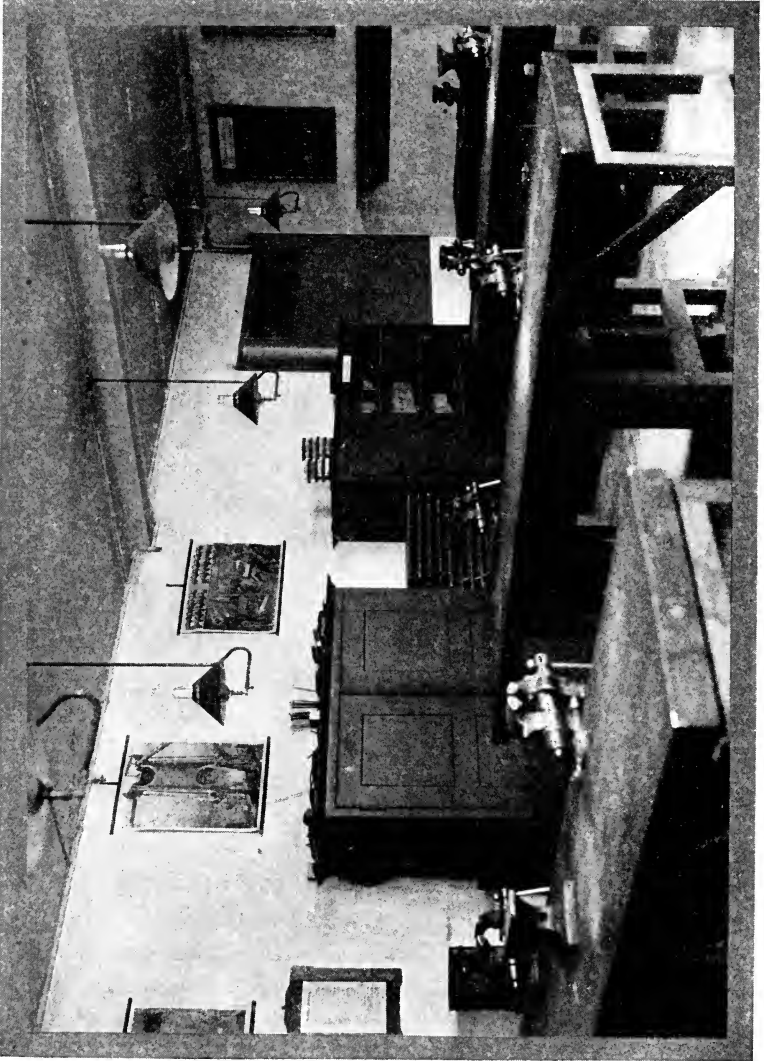

FIG. 78. METALWORKING SHOP, FLURSTRASSE PUBLIC SCHOOL, MUNICH

modeling and wood carving in 1904, reached the point in 1909 where more than forty per cent of eligible pupils took manual training and paid a small tuition fee for the privilege. An outstanding feature of the work in Mannheim was its correlation with art.

Strassburg, under German rule during this period, developed a composite system made up in part of exercise pieces of the French type and, in part, of useful models of the Leipsic type. Distinctive character was given to the Strassburg work by the courses in ornamental iron work, wood carving, and locksmith work developed on the French plan. As in Munich, so in Strassburg, the opposition to the making of useful objects came from the local artisans whose influence was strong because the instruction was free to pupils of the elementary schools. (1—91) It was, however, given outside of regular school hours as, for example, from five to half-past six on two evenings a week.

In Berlin the progress of manual training was very slow. Up to 1909, only five of the three hundred public elementary schools in the city were provided with shop equipment. On the other hand, a well-organized course, based on Leipsic principles, had been developed which emphasized the correlation of shopwork and drawing. A course in thin woodwork for the fifth and sixth grades was taught in some of the regular schoolrooms, the pupils working part of the time on the regular school desks and part on light bench tops clamped down on the rows of school desks. This course was published in 1906—*Die leichte Holzarbeit in Verbindung mit dem Linearzeichnen* by R. Frenkel. The benchwork course for the upper grades, *Die Hobelbankarbeit in Verbindung mit dem Linearzeichnen* by R. Frenkel appeared in 1911.

SOURCE REFERENCES

1. Goetze, Waldemar. *Illustrated Manual of Hand and Eye Training*. Translation published by O. Newman & Co., London.
2. Pabst, Alwin. *Handwork Instruction for Boys*. Translated by Bertha Reed Coffman. The Manual Arts Press, 1910.
3. Hoffman, B. B. *The Sloyd System of Woodworking*. American Book Co., 1892.

4. *Hand and Eye*. A monthly magazine. O. Newman & Co., London.
5. *Eighth Annual Report of the Commissioner of Labor*. Washington, 1892.
6. Kerschensteiner, Dr. Georg. "The School of the Future a School of Manual Work." *School and Home Education*. The Public School Publishing Company, Bloomington, Illinois.
7. Schmid, Ignaz. *Die Knaben-Handarbeit nach ihren dermaligen Stande zunächst in Deutschland*. Hermann Hillger, Berlin, 1908.

CHAPTER VI

TRADE AND TECHNICAL EDUCATION IN GERMANY

40. **General Statement.** In order to understand the character and importance of industrial education in Germany during the period under consideration in this volume, it is necessary to recall certain facts in the development of Germany as an industrial nation. Foremost among these is the fact that the German states did not suffer such rapid breakdown of the handicraft system of production on account of the Industrial Revolution as did France and England. The guilds and the apprentice system remained. Gradually the powers of the guilds were revised and subjected to more exacting government regulations; yet they continued to be a vital factor in maintaining apprenticeship, encouraging the more formal industrial education, and establishing conditions of admission to the trades. Meanwhile, however, as the factories multiplied, laws were enacted to regulate them also; so that there came to be two parallel and more or less conflicting industrial systems—one for handicraftsmen with their small-scale production, and the other for the manufacturers with their large-scale production.

A second fact to recall is that, since about 1848, elementary schooling has been free and compulsory in Germany, so that there has been a foundation upon which to build secondary industrial training.

A third fact is the great national impulse that came as the direct result of the victory over France in 1871. Under the guidance of Bismarck, the first chancellor of the German Empire, a comprehensive policy of industrial and commercial development was inaugurated. His purpose was nothing less than to make Germany the greatest of industrial nations, with the entire world as its market place. It was seen that such an expansion must involve a vast develop-

ment of technical education. The methods and findings of science must be applied to industrial processes; art instruction must be encouraged; new schools must be established; old schools must be reorganized; industrial workers must be more intelligent and more efficient. Money must be spent to bring about this desired educational result.

Already action had been taken looking toward compulsory attendance at continuation schools. The Regulation of Industry of 1869, under certain conditions, required employers "to allow their workmen under eighteen years of age to attend a recognized continuation school," and the communes were empowered to pass compulsory attendance laws. (1—522) For forty years and more, there had been growing up in every German city of considerable size a technical school which was capable, under the new national impulse, of much further development. Several notable schools for special industries had been established which were ready to expand with the development of these industries.

A further pertinent fact in this connection was that each of the states which became a part of the German Empire had its own educational system which it continued to control. This fact increases the difficulty of any author who attempts to classify the industrial schools of Germany. They have been so varied in character and supported in so many different ways that only a very general grouping seems to have significance. For the present purpose, the following classification has been adopted: (a) Continuation schools—part-time schools to supplement apprenticeship and to provide further education for other young workers and for journeymen employed in factories or elsewhere; (b) trade schools and secondary technical schools intended as a substitute for apprenticeship or as preparation for an industrial occupation of some kind, (c) industrial-art schools; and (d) higher technical schools.

41. Industrial Continuation Schools. The primary aim of the part-time, industrial continuation schools (*gewerbliche Fortbildungs-Schulen*) of Germany is to furnish apprentices and young industrial workers with the technical, business,

and civic instruction they need but cannot get in the shops where they are employed. Such schools continue the common school education of the youthful workers until they are eighteen years of age, but what is taught relates especially to their trades or occupations. These schools are, therefore, vocational rather than general. They seek to produce intelligent, efficient workmen and loyal citizens.

During the years 1873 and 1874, continuation schooling, with variations and limitations to suit local conditions, was made compulsory in more than a dozen German states, some making the requirement up to the sixteenth year, some to the seventeenth, and others to the eighteenth. (1—518). Gradually other states passed similar laws until 1891 when the Imperial Industrial Law (amended in 1900) required employers of labor "to grant to their apprentices or other workers (including all male persons, and female clerks and female apprentices) who are under 18 years of age the necessary time for such attendance at continuation classes as is required by the local authority of the district." (1—517) As the regulation of schools belonged to the individual German states, this Imperial Law was permissive only, but it served effectively as a practical ideal and produced marked results. (2—82) This law allowed classes to meet on Sundays provided they did "not interfere with attendance at Divine Service," (1—527) but Sunday classes became more and more unpopular, as did also classes held in the evening. In 1904, the Prussian Minister of Industry and Commerce issued a decree requiring that "classes in compulsory continuation schools shall be held during the daytime or close not later than 8 p. m., and that they shall be open on working days only." (1—529) He emphasized the importance of avoiding evening attendance. He said, "It is clear that growing boys after having worked in the shop from the early hours of the day, will scarcely be able to do justice to such requirements if the classes are held in the late hours of the evening. A continuation school working late will therefore incur the risk of failing to achieve its purpose and will not give an adequate return for the money spent on it. There

is also a serious danger of overstraining the young pupils.” (1—529)

The attitude of the Prussian Government toward the compulsory feature of the Imperial Law was stated in a decree issued by the Minister of Trade and Commerce in 1899:

There are still some who think that voluntary attendance at industrial continuation schools is preferable to compulsory attendance. I consider it my duty to draw attention to the recognized fact that, according to all ex-

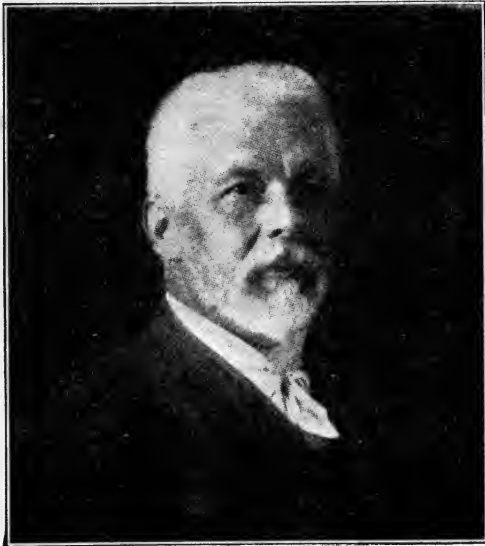

FIG. 79. GEORG KERSCHENSTEINER

perience down to the present time, the continuation school only flourishes and fulfills its purpose if attendance is made compulsory by a local bylaw. . . . There cannot be the slightest doubt that most of the young people who leave the elementary school at 14 years of age are neither in knowledge nor in character ripe to go out into life. With the loosening of the personal ties between master and workman, the danger grows that young people, after leaving the elementary school, will have to go without any further educative influence. Here the continuation school steps in with its purpose of forming the character of the young and of helping them to resist the temptations which are certain to present themselves to them in so many forms. This purpose can only be attained if the masses of the people, and not only the apprentices of certain favored industries, are brought under the influence of these schools.” (1—528)

The subjects of instruction varied with local ideals and conditions and the occupations of the pupils. In general, and especially in the case of apprentices, they may be grouped under four headings: (1) Drawing—freehand, mechanical, and trade, (2) practical arithmetic—bookkeeping and business methods, (3) science and technology of the trade, (4) German language and citizenship, and (5) physical training and personal hygiene. (Source Material VI A) Only in a few cities has instruction in practice of the trade, the shopwork, become a part of the curriculum of the continuation school.

42. The Industrial Continuation Schools of Munich. During the ten years following 1900, a new type of industrial continuation school developed in the City of Munich which attracted attention throughout the industrial-education world. In fact, it set a new standard for continuation-school instruction not only in many cities in Germany and other European countries, but it served as the model for many schools in America. This development was due to the educational philosophy and administrative ability of Dr. Georg Kerschesteiner, superintendent of public schools of Munich.

Dr. Kerschesteiner, Fig. 79, was born and educated in Munich where he completed the work of the common school, the normal school, the humanistic *Gymnasium*, and the University of Munich. In the latter, he specialized in physics and mathematics, and earned the Ph.D. degree. Before fitting for the University, he taught for two years in an elementary school, and after graduation held several educational positions before his appointment as superintendent of schools in 1895. Beginning in 1901, he wrote several books on education. By 1912, his ideas and his statesmanlike procedure in carrying them into effect had won such general approval that he was elected a member of the German Reichstag. (4—II, 237)

One morning, in the spring of 1900, Dr. Kerschesteiner read in the newspaper that the Royal Academy of Useful Knowledge at Erfurt had announced a prize competition on the theme, "How can we best train our young men for citizenship during the interval between their graduation from

elementary school and their entrance into the army?" Dr. Kerschensteiner had been intensely interested in studying this subject for several years, and was ready to answer the question. He wrote his now famous *Staatsbürgerliche Erziehung der Deutschen Jugend* (The Education of German Youth for Citizenship) and submitted it to the Royal Academy. It was awarded the prize, whereupon he urged the officials of his city to allow him to reorganize the continuation schools in accordance with the principles set forth in his prize essay. This permission was granted.

In this connection it should be made clear that Dr. Kerschensteiner approached the subject of industrial continuation schools not as a specialist in industrial education, but as a statesman-educator who was endeavoring to produce a higher type of citizenship for an industrial nation and believed in vocational education as a means to that end. As set forth in his prize essay, he maintained that the first aim of education for those leaving the elementary school should be "the development of trade efficiency and love of work, and with this the development of those elementary virtues which effectiveness of effort and love of work immediately call forth—conscientiousness, diligence, perseverance, responsibility, self-restraint, and dedication to a strenuous life." The second aim, he said, should be "to gain an insight into the relations of individuals to one another and to the State, to understand the laws of health, and to employ the knowledge acquired in the exercise of self-control, justice, and devotion to duty, and in leading a sensible life tempered with a strong feeling of personal responsibility." (5—25) The chief motive force in all this, he said, was love of work. He considered "the love of creative work" the chief motive in all education. (5—40) "All honest work is in itself a school of morality, at least so far as moral self-assertion is concerned." (5—99) Extending this thought to social service, he said, "This moral education can be given only by cheerful work in the service of others." (5—98) Later in the essay he said, "The most effective organization is doubtless that which allows the whole management of instruction and

education to grow out of a systematic introduction of practical work." (5—108) In setting forth his theory in another book he called attention to Goethe's opinion that "the only way to true culture lay through practical work, or, rather, through vocational training." (6—37) From Goethe, he quotes: "Handwork, such as can only be learned in its own narrow field, must precede all life, all action, all art. To know one thing well and to practice it, gives more culture than a half-knowledge of a hundred things." (6—36) In an address given in America in 1911, Dr. Kerschensteiner said:

I have the conviction even that education for a calling offers us the very best foundation for the general education of a man. . . . We are also still far too much inclined to assume that early education for a calling must necessarily be a narrow and one-sided education. Yet it lies in our power to make an education for a calling as many-sided as any education can be. Well-nigh every calling, if treated with sufficient thoroughness, naturally involves an enlargement of the field of conception and activity. Science enters today into the simplest work and incites all possessed of the necessary gifts to develop their knowledge, their dexterity, and their initiative. Indeed, experience has shown that the path of early education for a calling may lead to very much better results than the path of early education with no definite calling as a goal. We might say, the useful man must be the predecessor of the ideal man. Everyone must be able to do some good and thorough work though it be of the simplest kind, of one sort or another. Not till then will he be able not only to satisfy his fellowmen and be of use to his country, but also to make his own life of value to himself. And in the same measure as our lives gain value for ourselves do we attain power to reach a higher stage of culture. (7—2) (See Source Material VI, B)

Dr. Kerschensteiner's ideas were as seed sown in good ground. Munich was a city of small industries; the factory system had not done very much of its devastating work there. The craft guilds were still an important force in the city. Apprenticeship was the popular way of learning a skilled trade. That efficiency in any calling requires special training for that particular calling was a general principle universally recognized. (9—90) But to assume that apprenticeship, plus the continuation-school instruction then in vogue, were insufficient was contrary to tradition, and therefore to provide workshops in continuation schools would be an innovation. Dr. Kerschensteiner foresaw opposition and

made his plans accordingly. He made it clear that the workshop in the school was not to take the place of the practical work done by the apprentice in learning his trade; it was rather to supplement it. Not all masters who employed apprentices in the city were equally skillful as workmen and especially not all were equally good teachers of



FIG. 80. LIEBERSTRASSE SCHOOL, MUNICH

boys. The school workshop, in which it was proposed to have the most skilled master in Munich as a teacher, would help to correct that inequality of training. Moreover, the school workshop would make it possible to bring into the closest relationship theory and practice. The shop would thus serve as an instruction laboratory. This would react favorably upon the work done under the masters.

With such arguments, Dr. Kerschensteiner announced his plans and sought the cooperation of the guilds because he knew that he must have their assistance if the new work was to succeed. The first to volunteer their assistance were

the butchers, the bakers, the shoemakers, the chimney sweeps, and the barbers, and so it came about that these five trades were the first to have continuation-school workshops and the new courses of instruction. This was in the year 1900. The next year came the "wood turners, glaziers, gardeners, confectioners, wagon makers and blacksmiths, tailors, photographers, interior decorators, and painter's materials," and the new type of continuation school was established for each of them. Likewise, in 1902, schools were started for "hotel and restaurant waiters, coachmen, painters, paperhangers, bookbinders, potters and stove setters, watchmakers, clock makers, jewelers, goldsmiths, and silversmiths; in 1903, for foundrymen, pewterers, coppersmiths, tinsmiths and plumbers, stucco workers and marble cutters, wood carvers, coopers, saddlers and leather workers; and in 1905, for business apprentices, printers, typesetters, lithographers and engravers, building-iron and ornamental-iron workers, machine makers, mechanics, cabinetmakers, masons, stonecutters and carpenters." (9—89) So it continued; and in 1909, there were 54 industrial continuation schools for apprentices and in these there were 7818 students. (10—X, 263)

These schools were housed in four large central buildings, one of which is shown in Fig. 80; and in some of the elementary-school buildings of the city. The number of hours per week the students spent in school varied from six to twelve. A typical weekly program is the following for carpenters:

Religion	1 hour
Arithmetic and Bookkeeping	1 "
Studies in Life and Citizenship	1 "
Drawing	6 "
Practical Technology—wood, tools, machines, methods of doing work	2 "
	<hr/>
Total	11

Comparing this program with the one outlined in the previous section (cf. 41), one might conclude that no great change

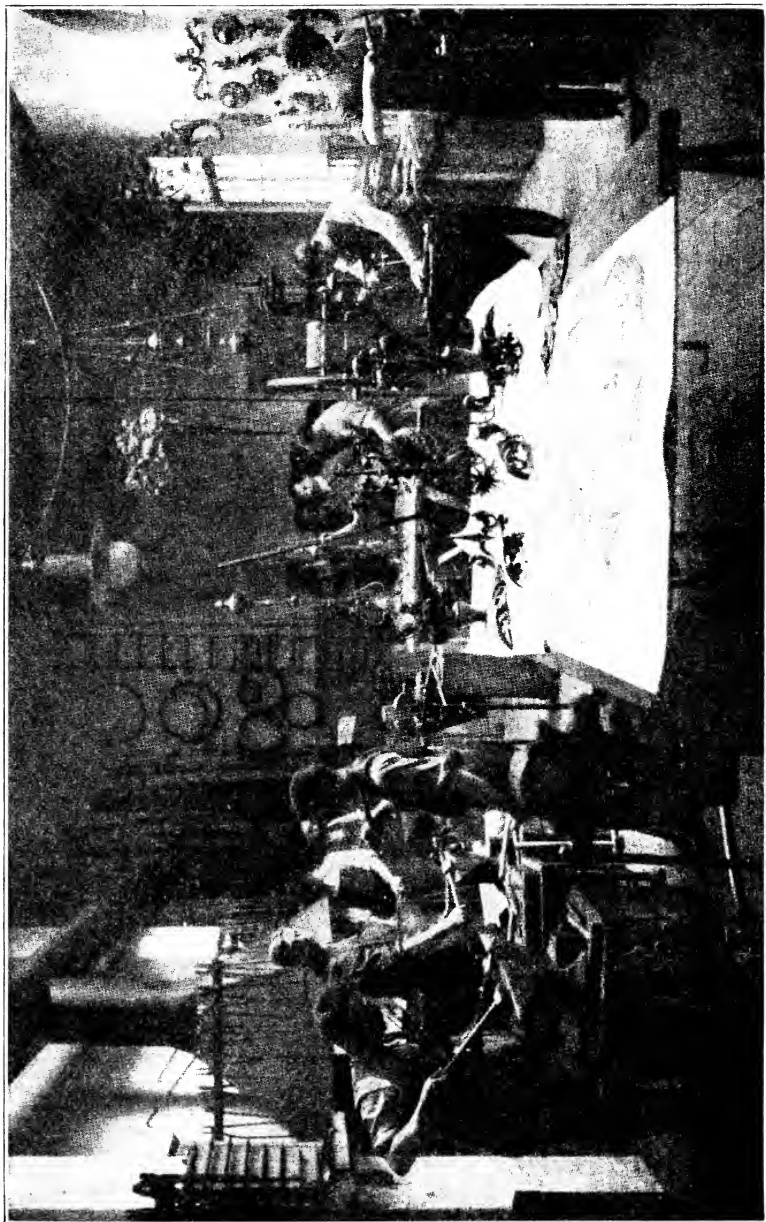

FIG. 81. WORKSHOP FOR ART SMITHING, MUNICH



FIG. 82. WOOD-CARVING SHOP, MUNICH

was made in the courses of instruction for continuation schools by Dr. Kerschensteiner; yet, in fact, he made a most important change when he provided the well-equipped workshop, giving it much of the character of a technical laboratory, and making it the center around which the instruction in the other subjects was grouped. Science, mathematics, technology, and drawing became, in fact, vital and interesting subjects when thus related to shopwork. (11—XII, 486) The technical character of the instruction in the Munich shops is suggested by the equipment shown in Figs. 81 and 82.

Another essential feature of Dr. Kerschensteiner's plan was cooperation between the schools and the guilds. It was only as fast as he was assured of such cooperation that he would provide the special equipment for the instruction in any trade. In fact, it was not until the guild representatives came to him and asked for the new type of school that he would make any effort to provide it. The new shop center for instruction in any given trade was thus a guild affair as well as the result of public-school policy. In many cases a guild would provide much of the equipment of the shop and become an important influence in its management.

43. Trade Schools and Secondary Technical Schools. As previously stated (cf. 40), there is a great variety of industrial schools in Germany. Busser, in his excellent monograph, says that "special schools exist in Germany for almost every trade known to the industrial world." (Source Material VI c) Some of these schools are intended as a complete substitute for apprenticeship and therefore give practical instruction in trade processes and in related science, mathematics, art, and technology, according to the needs of each particular trade or industry. Others provide only a part or none of the practical shop experience and place all the emphasis on the more theoretical subjects. In general, the higher schools give more attention to the theoretical subjects and drawing, yet there are several notable exceptions to this rule. Moreover, industrial conditions, financial support, and teaching ideals have changed through the years so that what was common at an early period has often been outgrown a few

years later. In the textile field, for example, what we now think of as the cruel spinning schools of the seventeenth century (12—63) “were gradually supplanted in the middle of the nineteenth century by the hand-weaving schools, most of which were later transformed into schools for mechanical weaving. In the latter, the instruction at first was chiefly confined to theoretical work in designing and patterning; but with the progress in the technics of the trade, the specialization in the industry and the intense competition, the opportunities for learning the textile trades thoroughly in the factories gradually decreased, so that it became necessary generally to substitute the school workshop for the apprenticeship system in the weaving industry. Therefore, most of the weaving schools are now equipped with machine looms, and much attention is devoted to the mechanical technics of the trade.” (3—35)

Textile School. An early and notable example of a textile school is the Royal School of Weaving, Dyeing, and Finishing at Crefeld. A government school had been in existence there since 1855; but, in 1878, when the silk industries of the town were suffering on account of the superiority of the products of other countries, especially of France, the Prussian Government and the local Chamber of Commerce sent commissioners to France to find out the reasons for the superiority of the French products. The commissioners reported that it was due quite largely to the “technical schools and schools of design, established in French manufacturing towns, and recommended that the Crefeld School should be completely reorganized and established in appropriate buildings.” (13—I, 134)

With municipal and State funds and the help of the manufacturers, a large and suitable building was ready for the new school in December, 1883. The British Royal Commission on Technical Instruction visited the school the next February. The following are excerpts from their report:

The building is a handsome structure of brick with decorated stone facings of the style of the Early Renaissance. . . . The ground floor contains reading room, lecture rooms, and classrooms for the weaving students. These

are all substantially furnished, with desks or tables, cabinets for objects, collections of patterns, lockers and drawers for the books, drawing boards and materials belonging to the students. In each room, there is a platform for the instructor and blackboard ruled in squares for diagrams and designs. The chemical, dyeing, and finishing departments are also on the ground floor.

On the first floor are the rooms for drawing and designing, the museum of textile fabrics, and the private rooms for the director.

The attic floor contains . . . a number of studios for designers.

The weaving shed . . . is supplied with winding, warping, spooling, and card-cutting machines, and a complete equipment of looms for varied patterns and combinations in all the textile materials, from silk ribbons and velvets to jute curtains and carpets; altogether there are 33 hand looms and 27 power looms. In the shed, there are two engines—a 12-horse-power compound steam engine, and a 4-horse gas engine.

The mechanics' shop for repairs contains a forge and anvils, a lathe for metal, shaping machine, boring machine, four vises, two grindstones, emery wheel, and saw sharpener, a lathe for wood, a circular saw, three joiners' benches, besides a number of small tools. . . .

Students are admitted to the school at 14 years of age provided they can pass the entrance examination. The complete course of instruction is of two years' duration, and begins and ends at Easter in each year. Special courses of a shorter duration may be arranged with the director. . . .

In order to carry out systematically the aim of the school, the course of instruction is divided into two sections, theoretical and practical. The first includes a thorough training in drawing and the second, practical instruction on the loom. Drawing and painting are taught from copies, models, and from plants and flowers, with adaptations to printing, and designs for other branches of the textile industry. Due prominence is given to geometrical and machine drawing, particularly to those parts of the loom which affect the pattern in the woven fabric. As much care is bestowed on the student with a mechanical turn as on one whose talent takes an artistic direction.

There are also lectures on textile fibers, on the elements of weaving, and on machinery. Fabrics are decomposed and explained; looms are arranged for weaving plain goods and for goods with simple designs in various materials by the students, while technical calculations and bookkeeping are systematically taught. In the second year the art instruction of the student is continued until he is able to invent and produce original designs. Lectures are given on the principles of ornamentation of woven and printed fabrics, while due advance is made in geometrical and machine drawing.

When the student shows capacity for higher work, he is admitted into one of the studios, where, under the special direction of qualified designers, he is encouraged to give play to his own imagination, and to produce new and original designs in color or otherwise, which can be woven by himself or other students on the premises, and submitted to the trade. In the technical and practical department of the second year, the student continues his studies in the decomposition of patterns, and in the composing and calculation of designed materials. He attends lectures on the construction, erection, and action of different looms, and of other machines used in weaving. He unmounts the power loom piece by piece and builds it up again. He works at

the forge, and learns the use of the machine and hand tools in the mechanics' and joiners' workshop. He cuts the cards in accordance with his own designs on the paper prepared by his own hands; he fixes the cards in the jacquard machine or engine, and finally becomes thoroughly practiced in the weaving of the most complicated and figured patterns both on hand and power looms. . . .

Without attempting to give a detailed description of the contents and general arrangements of the weaving shed, we may say that the varied and extensive collection of hand and power looms, the display of complicated and artistic patterns at work in the looms, and the businesslike air of the whole department impressed us exceedingly. Probably in no single factory in the world, as in no other existing school, can there be found so many examples of modern looms, or so great a variety of textile fabrics and designs, or more effective methods of imparting instruction in the processes of weaving. . . .

The dyeing and finishing departments of the school are arranged with the same completeness and efficiency as distinguish the designing and weaving branches. (13—134 to 138)

Building Trades School. A very early type of German industrial school was the special school for the building trades. Schools of this type were established in all cities and towns of considerable size throughout the Empire. Their chief purpose was to give theoretical instruction to meet the needs of the higher grades of workmen, foremen, draftsmen, inspectors, and the like in the building trades. They aimed to be the chief source of supply for technical workers next in rank below the architects and engineers. The admission requirements were usually one or sometimes two years' experience in a building trade and graduation from the elementary school (*Volksschule*) plus two years in the continuation school (6 hours of instruction or more per week), or an equivalent preparation in any one of the several types of German secondary schools. The studies most necessary for admission were the German language and arithmetic and, in some schools, if a promising student was deficient in one of these subjects, he was allowed to make it up in a special preparatory class. As in other special trade schools in Germany, a moderate tuition was charged. Scholarships, however, were often available for especially good students. The course of instruction in these schools formerly occupied two years, but later it was generally increased to two and a

half years. The following table of subjects and hours in the school at Breslau in the year 1900 is typical:

<i>Subjects</i>	<i>Number of hours weekly by semesters</i>				
	<i>1</i>	<i>2</i>	<i>3</i>	<i>4</i>	<i>Total</i>
German	2				2
Arithmetic	2				2
Algebra	4	3			7
Mensuration, plane and solid, and trigonometry	4	4			8
Natural Philosophy	2	2	2		6
Field measuring and levelling (surveying)			2		2
Building material study		3		1	4
Statics and stability study		4	5	4	13
Geometry	6	4	4	2	16
Building construction	16	12	12	6	46
Building knowledge, and agricultural, town, and business premises		4	5	8	17
Plans and projections for bridges, etc. (<i>Hochbauten</i>)			8	14	22
Form study	4	4	4	4	16
Freehand drawing	4	4			8
Knowledge of bylaws and other legal regulations affecting buildings				2	2
Estimates and incidental expenses			2	2	4
Trade bookkeeping				1	1
	44	44	44	44	176
Writing (as ordered by the Director)	1				
Modeling (as ordered by the Director)	4	4	2		
And the "first aid" instruction and fire drill				(14—60)	

The five-semester German building-trades course of 1912 was similar to the one given above but included more advanced technical subjects for the two upper classes and offered an opportunity to elect a course in civil-engineering subjects, chiefly bridge and railroad buildings, in place of the architectural subjects during the last year. (15—146)

Schools for the machine trades are similar in type to those for the building trades; though, as a matter of course, the drawing and technical subjects are adapted to machine construction instead of to building construction.

School of Cabinetmaking. A school of somewhat different type, yet fundamentally similar to the schools mentioned above was the Cabinetmakers' School in Berlin. Its purpose, when visited in 1909, was to train men for the higher positions in furniture making and interior decoration. The students in the school were masters and journeymen, also apprentices who had worked as much as two years at the trade. (2—101) If, for example, a master wished to be able to take contracts for furnishing rooms in a public building or private home in the style of a certain period but had insufficient training, either practical or theoretical, he might attend this school and secure the needed instruction. Or, if a journeyman had an ambition to become a master or to perfect himself as a workman, he might attend this school. Apprentices employed in their trade would come here in the evening or on Sundays for higher instruction.

The school dates back to 1879, when it was started as a guild school to give theoretical instruction to apprentices. In 1894, the school was taken over by the city as one of six evening schools for apprentices and placed under a single director. The school grew, its curriculum was extended, and its courses enriched. In 1895, in order to make the instruction in drawing more useful, parts of cornices and columns were made by students and some work done in wood carving and inlaying. This advance, however, was made in very cramped quarters. In the year 1902, the central division of the school moved into a new building constructed for the purpose, where it was supplied with the very best of equipment for both practical shopwork and drawing. It included a group of shops for cabinetmaking, wood turning, and wood carving, besides drawing rooms, lecture rooms, and classrooms. (16—6, 7)

As observed in 1909, this school had adopted a most effective method of studying historic styles in furniture. By means of photographs, sketches, color drawings, and notes made in the museum at Munich or Nuremberg or wherever the historic masterpiece desired for study could be found, a very complete record of the design and materials and methods

of construction was made. These were brought to the school and the students required to make accurate drawings of the cabinet. Then they constructed it in the shop by the same hand methods used by the craftsman who made the original cabinet. Such work by the old methods was followed by working out similar period designs by the methods of modern machinery.

On the theoretical side, the instruction was such as an expert in that trade would need; the chemistry of wood finishing, study of woods and other materials, estimating and trade arithmetic, bookkeeping, styles of furniture, wood-working machinery, and the like. (16—8)

This school had become so famous that in 1907 students came to it from Sweden, Norway, Russia, Denmark, and Bulgaria. (16—11)

44. Industrial Art Schools. There is another group of schools in Germany that has had a profound influence upon its industries, and that is the art schools, and especially the industrial art or *Kunstgewerbe* schools. One of the oldest of these schools—the one in Nuremberg—as early as 1865 was credited with having “contributed more than any other to the progress of the national industry” which was at that time chiefly the manufacture of children’s toys. (12—293) In general, the aim of these schools is to train art workers for trades in which a knowledge of color and design are required. Their first aim is to develop art feeling in their students and give them a thorough grounding in drawing, modeling, color, and design. Building upon this, the students acquired knowledge and skill in the various crafts and industries such as wood carving, metalworking, enameling, ceramics, printing, bookbinding, engraving, etching, textile designing, and the like. While these schools have varied in theory and in many practical details, the school at Munich may fairly represent the type. This school was founded in 1868 as a private institution but was later taken over by the State. The British Royal Commission in 1884 pointed out that a number of German potters sent their apprentices to the ceramics department of this school to learn modeling

and drawing and also painting on pottery. In the department of textiles, designs were being made for carpet and wall-paper manufacturers. (13—I, 159) In the lithography and wood-engraving department, young men and women were drawing their designs on stone and actually engraving wood blocks. The department of glass painting had become famous and the students of this department were in great demand by art-glass manufacturers. Likewise in wood carving, metalworking, interior decorating, and architecture, the work was made very practical. (13—I, 160)

The school maintained a separate department for women. In 1913, the instruction in this department included, besides the courses in general and applied drawing and painting, courses in pattern drawing for textile industries, decorative painting and drawing, illustration, plastics and sculpture, metal chasing, glass painting, architectural drawing, and a course in drawing for teachers. (17—1173)

A feature of the drawing work in this school in 1909 was the outline pencil-drawing studies of large, beautiful birds and shells which constituted a major part of the models in one of the studios. Such studies of shapes and areas were followed by similar studies of the same birds or shells in tone and in colors. These studies were considered an excellent preparation for designing.

In addition to the several types of schools already mentioned, there is another, the technical high school (*Technische Hochschule*), which is at the top of the system of industrial education in Germany. These schools, however, are not of secondary grade but correspond approximately in grade to the engineering and applied science schools or university departments in America. (12—347) They train the technical leaders and in doing so give much attention to scientific investigation. "The scientific training and investigating spirit of these schools have made possible many of the discoveries in chemistry and electricity by which methods of manufacture have been revolutionized, industrial processes cheapened, natural resources conserved, the waste products of farm, mine, and factory utilized in the production of

valuable new commodities—and the foreign trade of Germany thereby increased many millions of dollars annually. At all of these institutions are departments for architecture, civil, electrical and mechanical engineering, chemistry, and general science. At some of them are added certain other departments such as shipbuilding and marine engineering," mining, and metallurgy, pharmacy, naval architecture, forestry, agriculture, etc. (3—43)

SOURCE MATERIAL VI, A

SUBJECTS OF STUDY IN THE INDUSTRIAL CONTINUATION SCHOOLS
OF GERMANY

From *The German System of Industrial Schooling* by Ralph C. Busser

In selecting the subjects of instruction, the aim is to serve the civic, vocational, and economic interests of the apprentices and cultivate in them the technical knowledge, artistic sense, and idealism that, with the necessary mechanical skill and practical experience, go to make the master-craftsman. The vocational studies (*Fachkunde*) are designed to broaden as much as possible the apprentice's knowledge of his trade and to educate him for efficient and conscientious pursuit thereof. For classes which embrace single trades or groups of trades, this expert or technical instruction includes elementary geometry, professional trade drawing, machine drawing, and the sketching of designs from prepared drawing cards; and also, if the expert teachers and other facilities are available, the handling of raw materials, tools, machines, and working models. For practical manual instruction, however, especially that relating to the particular trade, one must look, as a general rule, to the more advanced or specialized institutions, such as the industrial-art schools, mechanics' evening schools, and the special trade schools. In some large industrial continuation schools, algebra, physics, chemistry, natural science, and mechanics are taught in elementary form. In the great majority of schools, however, these advanced subjects are omitted, because the very limited period of instruction must be devoted to more necessary studies.

BUSINESS INSTRUCTION

Another illustration of the practical nature of the instruction in well-organized industrial continuation schools of German cities, is the teaching of business methods and affairs (*Geschaeftskunde*), the knowledge of which will be useful to an artisan or mechanic in the carrying on of his particular vocation whether as employer or subordinate. The apprentice or learner is given such instruction in industrial bookkeeping and arithmetic as can be applied to his trade; he is taught the principles governing production, distribution, and consumption, the sources of supply of raw materials, the market for the products of his trade, the computation of cost and the fixing of prices; he learns about simple mercantile and credit relations, insurance, postal affairs, and railroad traffic; he is informed as to the appropriate industrial laws and regulations, hygienic requirements of the workshop, the functions of chambers of commerce, guilds and other industrial organizations, trade customs, etc. In the arithmetic course, a study is made of checks, drafts and bills of exchange; currency, weights and measures; interest, percentage, commissions, contract estimating, etc.

GENERAL INSTRUCTIONS FOR UNSKILLED WORKERS

The most difficult task of the German industrial continuation schools, especially in the large cities, has been the planning of the instruction for the unskilled workers; namely, those not apprenticed to or learning any particular trade, but performing unskilled or automatic labor as barrow men,

drivers, deliverymen, helpers, or machine operatives in the various industries.

In the selection of studies for this class of boys, the chief aim of the well-organized German continuation schools, such as those of the large cities, is to enable them to learn the principles governing their industrial environment and the means by which they may advance themselves economically, and, at the same time, broaden their general education. Appropriate connecting ideas are the entrance of the boy into industrial life, his position in the working community, the activities of factory, workshop and general traffic, and the system of work and co-operative service. The care of the health and the proper use of spare time are taught. Besides the instruction in language, religion, civics, and other subjects which apply to all classes of workers, they are taught simple courses in domestic and industrial bookkeeping and other business studies suited to their position in life. The written work and arithmetic are closely connected with vocational and civic affairs, and the endeavor is to fix the instruction by practice and application. The aim is so to handle the instruction that it applies most appropriately to the student's occupation and place in the industrial organization. When practicable, this is accomplished by examples from actual life rather than by theoretical discussions. Proper consideration is, of course, given to the practical experience and intellectual ripeness of the students. Naturally, the plan of instruction covers a wide range, as the intellects of unskilled workers show such extraordinary variation. In this connection, one of the most difficult tasks is the organization of these workers in classes in accordance with their widely different capacities. Where they are mostly employed as helpers or operatives in a town's principal industry, like the manufacture of textiles or small metal goods, the instruction is arranged accordingly. It is said that, in localities where the boys seldom change their occupations, it is easier to organize the classes according to the kind of business.

CULTIVATION OF CITIZENSHIP

The making of competent workmen is by no means the exclusive aim of the German industrial continuation schools. The cultivation of intelligent citizenship, patriotism, and the co-operative spirit among the workers, is considered quite as essential in the promotion of national efficiency as manual skill and technical knowledge. The ideal sought to be attained by the system is the enlightened citizen who is capable of performing efficiently his social and civic obligations as well as the tasks of his vocation, and who "not only seeks to advance his own welfare through his work, but also consciously places his labor in the service of the community." As means to this end, there has been introduced in the industrial continuation schools of many German cities, a course of instruction in "civic affairs" (*Buergerkunde*), including studies designed to teach the connection of the individual calling with the common life in the family, school and workshop, in the community, State and Empire; to explain the genesis and system of important public institutions; to cultivate reverence for the Constitution and public laws, loyalty to the home and Fatherland; and to induce earnest and patriotic co-operation in the affairs of the community and nation. For example, the students are instructed as to the local municipality and its various departments; public hygiene and sanitation; system of taxation; laws for the protec-

tion and insurance of workers; the operation of courts of justice; the function of the chief public authorities; important facts about the organization and administration of the State and Empire, the Army, the Navy and the Colonies.

PHYSICAL TRAINING AND RECREATION FACILITIES

Other praiseworthy features of the German continuation schools, designed to promote national efficiency, are the physical training and recreation facilities (*Jugendpflege*). In the well-organized schools, the obligatory studies in this division embrace elementary physiology and personal hygiene (such as care of the body, bathing, clothing, food, temperance, etc.), and the rendering of first aid to the injured. For the voluntary participation or use of the students, many continuation schools, especially in the larger cities of Germany, provide gymnasiums, swimming pools, playgrounds, and other athletic facilities; and regular instruction is given in gymnastics, swimming, and field sports. While prizes are frequently offered and other measures taken to induce the students to participate in the gymnastic exercises, outdoor sports and games, and in the walking tours arranged by the teachers, the use of compulsion is discountenanced upon the principle that force leads to opposition, and that those who unwillingly take part in athletics would receive little or no benefit therefrom. In addition to these facilities for voluntary physical training, the continuation schools frequently provide for the optional participation or attendance of the students in other forms of education, culture and entertainment such as lectures, concerts, dramatic performances, singing classes, reading and game rooms, and excursions for visiting museums, factories and other places of historic or industrial interest. These excursions, which are conducted by the appropriate teachers, are exceedingly interesting and valuable to the students in the concrete examples of civic and technical instruction thus afforded. (3—15 to 19)

SOURCE MATERIAL VI, B

BASIC CONSIDERATIONS IN ORGANIZING CONTINUATION SCHOOLS

From *Organisation und Lehrpläne der Obligatorischen Fach- und Fortbildungsschulen für Knaben in München* by Dr. Georg Kerschensteiner.

Translated by Howard G. Bennett

1. The ultimate goal of all public schools supported by public funds is the education of the pupil so that he may become a useful citizen. A useful citizen is one who through his work directly or indirectly contributes to the fulfillment of the aims of the state as a society of law and culture. The first task of the school is therefore to further as much as possible the pupil's capacity for work, and therewith his joy in work. The second task is to accustom the pupil early to place this joy in work and fitness for work in the service of his fellow pupils and fellow beings. The third task is to unite the readiness for service, thoughtfulness, and moral devotion thus gained with understanding of the ends of the community, in so far as such understanding can be engendered in the pupil, according to his talent and his maturity. Our

schools of today are not entirely conscious of this threefold task. Where they are well organized, they seek at most to accomplish the first task—education for personal fitness. But they are not schools for social service.

2. The schools for the great masses of our countrymen, the regular *Volkschulen*, do not even go so far as to carry through successfully the first task. For they stop just when education in and by means of a specific vocation begins. They can therefore in no way further true fitness for and joy in work. On the other hand, the relation of the apprentice to his vocation between his 14th and 18th years, both in industry and in handicraft, business, and agriculture, leaves so much to be desired, that most workers during their introduction into a specific vocation arrive at neither a right understanding of nor fitness for work, not to mention productive joy in work. But outside the foundation of fitness for and joy in work, moral education is also excluded (i.e. moral education cannot be accomplished except through fitness for and joy in work). It is therefore absolutely necessary to enlarge the *Volksschule* by an added school organization which will seize directly upon the boy's vocational life, handle its problems as fundamentally as possible, deepen, enlarge, and ennoble them, and therewith give fitness for and joy in work. This enlargement of the *Volksschule* can happen in very different ways. For the education of the masses, the continuation school is at present the best way; that is, a school which accompanies the boy and girl during their apprenticeship. This continuation school can then at the same time also attack the other two problems—education in consideration for others and devotion to common ends, and education in service to society.

3. In order to accomplish the first task, education in fitness for and joy in work, the educational impulse of the continuation school must place the pupil's practical work directly at the middle point of his activity and unite in the closest manner all other teachings of a commercial, economic, scientific, aesthetic, and moral sort, with practical work. Where it is possible, as in all large cities and in all purely rural communities, the boys and girls are divided according to vocational groups and then led through vocational education into higher intellectual and moral education. This vocational continuation school must be obligatory for all boys and girls until their 17th or 18th year, just as the *Volksschule* has been heretofore. Its instruction time should amount to not less than six hours a week and should not be placed in the evening, but fitted into the regular day's work of the boy or girl. Where it is at all possible, special teachers who will make this their chief work should be appointed. For only then is it to be expected that these teachers will dedicate their entire strength to the difficult problem of this school. These schools should, like the *Volksschulen*, be free; their costs should be shared equally by the community and the State. (8—8 to 10)

SOURCE MATERIAL VI, c

GERMAN TRADE SCHOOLS AS A SUBSTITUTE FOR APPRENTICESHIP

From *The German System of Industrial Schooling* by Ralph C. Busser

Special schools exist in Germany for almost every trade known to the industrial world, and they have in no small degree aided in the thorough equipment of German workmen for their respective trades, to which is so largely

due the marvelous development of the country's industries, and the consequent rapid spread of material prosperity and well-being in spite of the heavy burden of State and local taxation. It should be borne in mind, however, that the Germans do not believe in the plan of teaching trades *wholly* in the schools, except when the conditions in a particular industry are such that the necessary training of the learners cannot be provided. This is peculiarly the case in the textile industry, where the necessity for special technical knowledge and the acquisition of high skill in handwork, as well as in the operation of the complicated machinery of the trades, led to the establishment of special schools for spinning, weaving, knitting, rope making, dyeing, finishing, ribbon and lace making, embroidering, etc. Even in many of these schools, a requirement for admission is previous practical employment in a textile factory. Other important institutions which substitute school for apprenticeship training, *in whole or in part*, are the special schools for the metal trades (*gewerbliche Fachschulen für Metall-Industrie*) in the Prussian cities of Schmalkalden, Siegen, Iserlohn and Remscheid; the School for Copersmiths at Hanover; the Tanning School at Frieberg, Saxony; the School for Clock and Watchmaking at Furtwangen in Baden; the schools for basket making at Lichtenfels in Bavaria and Heinsberg in Prussia; the schools for straw plaiting in the Odenwald and Black Forest, and in Saxony; and the schools for pottery and for woodworkers in various parts of Germany. Among the minor trade schools, most of which are maintained by trade guilds, manufacturers and industrial associations, are found schools for bookbinders, printers, decorators, dyers, shoemakers, hatters, tin workers, plumbers, locksmiths, blacksmiths, gardeners, brewers, bakers, millers, butchers, tailors, barbers, etc.

Besides the incompleteness of the practical training which the learners in many trades would receive if dependent upon the trade schools, there are certain economical disadvantages in the general substitution of special trade schools (*gewerbliche Fachschulen*) for apprenticeship, such as the tremendous expense to the State of providing adequately equipped workshops (estimated in Prussia at \$100 to \$125 per year for each student), the corresponding cost to the parents of supporting the boys during the period of instruction now to a large extent borne by the employers to whom they are apprenticed, and the enormous loss to industry that would result from the absence of apprenticeship labor.

COURSES OF INSTRUCTION

The regulations governing admission to the industrial-art schools and mechanics' evening schools, have no application to the special trade schools, which fix their own entrance requirements according to the standard of the school and the conditions in the respective industry. If it be a trade preparatory school, or a trade school aiming to take the place of apprenticeship in whole or in part, then the only condition precedent to entrance is in most cases completion of the eight years' course in the common schools (*Volks-schulen*). If, however, it be an advanced trade school designed not to *replace* but to *supplement* the learning of the trade under the apprenticeship system, then admission may be confined to those who have already had one or two years' practical experience in the particular industry, or even to those

who have passed through the period of apprenticeship and become journeymen. While attendance at an industrial-art school, school for mechanics, or elementary trade school, will in some German States relieve one of the obligation to attend the industrial-continuation school (*gewerbliche Fortbildungs-Schule*) for the corresponding period, the special trade schools, as a general rule, can be entered only after completion of the continuation school course or of equivalent instruction, in order to insure proper maturity of mind in the learning of a difficult trade.

The curriculum of the typical German special trade school for the highly skilled crafts may be divided into three general parts: first, the *theoretical or technical instruction*; second, the *business teaching*; and third, the *practical manual training*. In the *theoretical or technical course*, the most important studies are drawing, mathematics, and industrial art. In the latter course, the most time and attention is devoted to drawing, not only on account of its practical application to the trade being taught, but because it trains the mind and eye, cultivates the sense of proportion and mechanical correctness, and develops a taste for the harmonious and artistic. The course in arithmetic is chiefly devoted to technical calculations which are incidental to the special trade taught in the school; and in geometry, to the practical application of geometrical relations. The purpose of the *business teaching* is to prepare the student for the practical conduct of the business of his trade. Hence, he is taught the principles of production and consumption; computation of cost and fixing of prices; the sources of raw materials used in, and the market for the products of, his industry; the method of bookkeeping most suitable to his trade; and the important laws and regulations governing the conduct of the particular trade or industry. The *practical manual training* is in the form of shop practice in the school itself to the extent that it is equipped with the necessary tools and machines, or in the associated factories or workshops of the locality. Where the manual work is done in the school, the instruction is generally given by a master-workman who may be regularly engaged in the industry itself, or who at least has kept in touch with the modern conduct of the trade and the latest improvements in tools, machinery, and industrial processes. Thus, by affording to factory artisans and the journeymen of the trades the opportunity of learning the use of the best machines and appliances, the most time-saving methods, the highest type of manipulative skill, and the most efficient and economical industrial processes, there is a constant tendency to evolve new ideas and inventions, improve the work, and cheapen the cost of production. Without the special trade schools, many apprentices would have made no progress beyond the industrial training possible in an antiquated factory with out-of-date machinery or old-fashioned methods. As it is, the German craftsmen, with their specialized trade-school education, have had much to do with the development of the splendidly equipped modern factories and other industrial establishments, by means of which Germany in recent years has become one of the leading exporting nations of the world. (3—29 to 32)

SOURCE REFERENCES

1. Sadler, M. E. *Continuation Schools in England and Elsewhere*. The University Press, Manchester, 1908.
2. Beckwith, Holmes. *German Industrial Education and Its Lessons for the United States*. U. S. Bureau of Education Bulletin No. 19, 1913.
3. Busser, Ralph C. *The German System of Industrial Schooling*. Study No. 40, Public Education Association, Philadelphia, 1913.
4. *Vocational Education*. The Manual Arts Press, Peoria, Illinois.
5. Kerschensteiner, Dr. Georg. *Education for Citizenship*. Rand McNally & Company, Chicago, 1911.
6. Kerschensteiner, Dr. Georg. *The Schools of the Nation*. Translation by C. K. Ogden. Macmillan and Co., Limited, London, 1914.
7. Kerschensteiner, Dr. Georg. *Three Lectures on Vocational Training*. The Commercial Club of Chicago, 1911.
8. Kerschensteiner, Dr. Georg. *Organisation und Lehrpläne der Obligatorischen Fach- und Fortbildungsschulen für Knaben in München*, Munich, 1910.
9. Hanus, Paul H. *Beginnings in Industrial Education*. Houghton Mifflin Company, 1908.
10. *Manual Training*. National Association of Manual Training Teachers, England.
11. *Manual Training Magazine*. The Manual Arts Press, Peoria, Illinois.
12. Bennett, Charles A. *History of Manual and Industrial Education up to 1870*. The Manual Arts Press, Peoria, Illinois, 1926.
13. *Second Report of the Royal Commissioners on Technical Instruction*, London, 1884.
14. Baker, James. *Report on Technical and Commercial Education in Prussia, Poland, Galicia, Silesia, and Bohemia*. Board of Education, London, 1900.
15. Cooley, Edwin G. *Vocational Education in Europe*. Report to the Chicago Commercial Club, 1912.
16. *Berliner Tischlerschule*. Report for the School Year, 1907-08.
17. *Report of Royal Commission on Industrial Training and Technical Education*, Canada, 1913.

CHAPTER VII

MANUAL TRAINING IN ENGLAND

45. **The Background.** The history of manual and industrial education in England is the record of a varied assortment of special educational movements converging into each other or growing out of one another rather than a record of comprehensive and continuous development. The earlier of these movements were for the education of "the poor"; then came movements to benefit the "lower classes"; later, with the principle of free public education accepted, came broader democratic movements for manual training and technical, art, and modern vocational education.

Before the Industrial Revolution, the ruling classes in England considered that the education of the lower classes should be confined to the requirements of their occupations. Knowledge of the outside world made the worker less fit to go through his daily tasks "with cheerfulness and contentment." Many of the ruling class accepted the idea that, in the ideal social state, it was essential that a large proportion of the people be ignorant and poor. It took a hundred years of educational effort to change this idea and adopt a comprehensive plan of elementary education at public expense.

It is a significant fact that the first institution to oppose this ideal of ignorance for the poor was the church. The missionaries of the church sought to teach poor children to read the Bible. This involved schools for such children. But the parents were not willing to send their children to school. They saw no advantage in schooling and they considered it their right to profit by the manual labor of their children. And, no doubt, many of the parents needed all the children could earn. To meet this objection, the representatives of the church provided more or less profitable labor for the children during a large part of the day in order to be allowed

to teach them to read for an hour or two a day. In this way the schools for the poor purchased the privilege of teaching children to read the Bible. To a considerable degree, the plan was a success, and it resulted in the movement known as Schools of Industry.¹ The ruling classes feared the results of teaching writing and arithmetic, and so, in most of these schools, only reading was taught. The school, they thought, must not be allowed to accomplish more than save the souls of the poor children and help them to become better servants.

The Industrial Revolution, by attracting the working poor people to the industrial towns and accepting children as workers in the factories, greatly multiplied the number of delinquent children and increased the criminal class to such an extent that in the early part of the reign of Victoria, there was fear that the seeds of the French Revolution that had been planted among the laboring and criminal classes in England might grow into an uprising against the Government. This state of affairs, added to religious zeal, brought into being the Ragged School Movement.² As in the School-of-Industry Movement, so, in this one, volunteer teachers came to the rescue of these poor and wretched children.

The manual work in these schools was considered important. It was varied in character according to local conditions. In general, it was intended to teach the children to be industrious, and to go as far as possible toward teaching them some occupation by which they could earn an honest living; but, with the means at hand and the teachers available, it was usually not possible to go very far. The continued growth of this movement and its evident results helped prepare the public mind for free public elementary education and for manual training.

Out of the Ragged School Movement grew the Polytechnics, which were for the social, moral, and educational improvement of adults. These will be considered more fully in another chapter (cf. 62).

¹Bennett, Charles Alpheus. *History of Manual and Industrial Education up to 1870*, p. 88.

²*Ibid.*, p. 222.

Another educational movement for adults, quite independent of the Ragged School Movement, yet parallel to the early part of it, was the Mechanics Institute Movement.³ This movement flourished in the centers of population from 1824 to 1848, and then, as a movement, subsided, many of the institutes developing into technical schools and a few keeping their original character even to the present time. It was intended especially to help mechanics, through lectures on scientific and mechanical subjects; but, strange to say, the lectures attracted a much larger number of persons who were not engaged in mechanical pursuits. One reason for this was that a large proportion of the mechanics did not have sufficient elementary education to enable them to understand the instruction given by the lecturers. The realization of this fact helped to hasten the coming in of free public schools and compulsory attendance.

The educational movement that most directly influenced the early development of manual training was that which brought art and technical schools into being in order to provide skilled workers for the industries. This movement, as will be made clear in the next chapter, grew out of the intense industrial competition between England and the leading countries of Continental Europe. The consciousness of having lost a certain amount of prestige in competition with France and Belgium and the fear of a similar loss with Germany called forth warnings from leaders of industry, education, and government.

Among these was Professor Thomas Henry Huxley, (1825-1895) who called attention to "the serious consequences of neglecting to provide technical instruction for all classes of workers." (1-85) Professor Huxley laid stress on instruction in science—especially in the scientific method—as a foundation for success in industry. He recognized also the necessity for an enriched course of instruction in the elementary schools. (2-839)

In an article in the *Contemporary Review* for September 1880, Professor Silvanus P. Thompson (1851-1916) pointed

³Ibid., p. 301.

to the decadent condition of apprenticeship. He said that boys who entered the shops were not properly instructed but were "made the drudges of the older workmen." (3—XXXVIII, 473) The apprentice was merely a boy worker with less wages. It was no one's duty to teach him. Then Professor Thompson went on to state what kind of education the young artisan needed and, in doing so, he said that the literary training of the elementary schools gave a distaste for manual work and that the graduates of the schools "prefer to starve on a threadbare pittance as clerks or bookkeepers rather than earn a living by the less-exacting and more remunerative labor of their hands." (3—XXXVIII, 475) He foreshadowed the manual-training movement, which was to come in a few years, when he said:

Obviously, with such facts as these staring us in the face, we must admit a flaw in the training given in our primary schools, if its result is in so large a number of cases to destroy the natural capacity for manual labor. The fault is not so much in the amount of education as in the nature of the studies. For many trades, the training of the hand to work may, and in some must, begin at an earlier age than that at which many children leave the elementary school. In some trades, indeed, the masters definitely refuse to take apprentices above a certain age; if they did take them, the union would interfere. The taste for manual work is imbibed at a very early age, and there is not wanting evidence to prove most distinctly that even a very small amount of manual labor introduced into the elementary school serves to keep alive the capacity for active employment, and the manipulative skill of the fingers.

The first and most obvious step to be taken to bring about the urgently needed remedy is to render at least permissive, if not authoritative, a reform more or less sweeping in character in the instruction given in our elementary schools to boys and girls between the ages of ten and fourteen. For this class of children, the provisions of our existing educational code could not possibly be more unsatisfactory than they are, when regarded from the point of view that these children will in a few months have to work for a part at least of their own living. The crumbling edifice of apprenticeship is made to repose upon a basis of literary studies which positively unfits the young apprentice to enjoy the few benefits which that obsolete institution can still offer. (3—XXXVIII, 475)

Professor Thompson especially recommended that certain literary subjects be postponed to a later period in school life in order to make a place for mechanical drawing and the elements of the physical sciences. He would lengthen the

period of schooling. Most important of all, he would have children gain "some skill with their fingers ere they pass the perilous point at which their taste or distaste for work may be acquired." (3—XXXVIII, 476)

46. **Public Elementary Schools.** Conflicting opinions concerning education, religion, charities, and public responsibility delayed the development of a unified system of elementary schools in England. In fact, the Elementary Education Act of 1870, passed during the ministry of William E. Gladstone, was the first British law to provide even the basis for an adequate scheme of elementary education. This Act required that there "be provided for every school district a sufficient amount of accommodation in public elementary schools available for all the children resident in such district, for whose elementary education efficient and suitable provision is not otherwise made." (4—19) This Act enabled local school boards to adopt bylaws requiring compulsory attendance of all children between the ages of five and thirteen. (4—20) The compulsory feature of this Act, however, was not entirely effective until the further Acts of 1876 and 1880 had been passed. Then complete abstinence from employment and complete school attendance were enforced up to ten years of age. (4—26) But elementary schooling, even in London, was not free to all children until 1905.

Long before the Elementary Education Act of 1870, however, various forms of handicraft were sometimes found in the schools, partly supported by public grants. The Government inspector's reports for the years 1847 to 1850 reveal that needlework was given much attention in such schools. The organization of the needlework at that time was based on a manual issued in 1816 by the British and Foreign School Society. (5—113) In the first scheme of instruction drawn up by the School Board of London, and also in the one by the Education Department of the Government, the inspectors of literary subjects were held responsible for the inspection of needlework, but they were allowed to ask ladies connected with the management of the schools to assist

them. In May, 1873, the School Management Committee of London recommended that a special inspector of needlework be appointed. In July of that year, a Mrs. Floyer was appointed examiner of needlework. (6—41) Thus began what has become an extensive system of practical instruction for girls in the public schools of London.

The first suggestion that the teaching of cookery should be introduced into the girl's departments under the London School Board was made in June, 1874. In 1875, two classrooms were opened in which instruction in cookery was given to pupil teachers and elder girls, and two more classrooms were added the following year. In 1878, a more comprehensive scheme was adopted. It was decided to build cookery classrooms, technically called "centers"⁴ in the playgrounds of suitable Board schools, in which pupils from the Board schools within convenient distance from the center were to receive instruction in cookery. (6—41)

In October, 1874, the School Board of London resolved that systematized lessons in drawing be given in all Board schools "so that all scholars may have an opportunity of learning drawing." The Board also required that all their permanent teachers should obtain the full drawing certificate. In 1882, a drawing inspector was appointed. Within a few years, drawing was a compulsory subject of instruction for all boys and it was an optional subject for girls. In a few schools, special classes were formed with selected pupils who were given further instruction in drawing and in clay modeling. (6—40)

In December, 1884, the School Board of London decided to try the peripatetic plan of teaching "mechanics" in some of the schools. In six months from that time, twenty schools commenced on this plan. The science demonstrator gave a lesson fortnightly to the boys in the fifth and higher standards, the lesson being illustrated experimentally by specimens and apparatus carried from school to school. Between the visits of the demonstrator, instruction was given by the class teacher, who was present at the demonstrator's lesson. The plan was considered successful and, in 1887, was extended to other parts of the city. (6—42)

⁴Called centers because they received pupils from several schools.

47. **Industrial Schools.** Ever since the founding of the Philanthropic Society in 1788, England had been substituting the industrial school for the prison as a means of reforming juvenile criminals. Industrial schools for beggars, waifs, orphans, and other poor and unfortunate children were quite common before the middle of the nineteenth century. As early as 1838, England is said to have exceeded all other countries in eleemosynary institutions.⁵ It was quite in accord with precedent, therefore, that the Elementary Education Act of 1870 should have given power to School Boards to provide in some special way for the education of juvenile delinquents and young criminals. This Act and the Act of 1876 gave School Boards the option of maintaining children in "voluntary⁶ industrial schools or of establishing industrial schools of their own. The Board was empowered to appoint officers to bring such children before a magistrate in order that they be sent by him to an industrial school. The following classes of children might be sent to such a school: "Under 12 years of age, a 'child who is charged with an offense punishable by imprisonment, but has not been convicted of felony.' Under 14 years of age, a child (a) 'begging or receiving alms'; (b) 'found wandering and not having any home or settled place of abode'; (c) 'found destitute, either an orphan or, having a surviving parent, undergoing penal servitude'; (d) 'frequenting the company of thieves'; (e) 'where the parent or step-parent represents that he is unable to control the child, and that he desires that the child be sent to an industrial school'; (f) 'lodging, living, or residing with common or reputed prostitutes or in a house resided in or frequented by prostitutes for the purpose of prostitution'; (g) 'frequenting the company of prostitutes.'" (7—94)

The industrial occupations in the schools for such children varied a great deal, especially in the voluntary industrial

⁵See Bennett, Charles Alpheus. *History of Manual and Industrial Education up to 1870*, p. 215.

⁶An elementary school supported by voluntary subscriptions, or not maintained by a school board or local education authority.

schools. They varied because of the surroundings, whether in the country, in the city, or on board a ship; they were fundamentally those that helped in maintaining the institution. Only in a minor degree or in special cases was the work of such a nature as to fit boys definitely for a skilled trade. But the value of the work in maintaining discipline and in helping in moral reform was recognized. However, it was stated by the Poor-Law Commissioner in 1839 that the object of the industrial work was "not to make profit of their labor" but to help them to acquire "habits of industry, skill in some useful art, and such correct moral habits" as to render their service desirable.⁷

48. **Shopwork in Secondary and Technical Schools and Colleges.** While public elementary education was developing under the Act of 1870, looking toward the time when every British boy and girl would be given an elementary schooling that fitted just as well for industrial life as for professional life, another development was taking place in the secondary, technical, and engineering schools and colleges that prepared the way quite definitely for the introduction of manual training into the elementary schools. This was the gradual development of shopwork in wood and metals as courses in these schools. Several such schools were visited by the Royal Commissioners, and their observations are contained in their report of 1884.

One of the earliest of the schools to give serious attention to shopwork was the Bedford Grammar School, a richly endowed institution. This school was noted for its efficient technical and engineering department. (2—I, 155) Shopwork began in the "grammar-school" or classical department as a means of "recreation for the boys during a portion of their play time." There were "small shops for carvers and fitters." (8—I, 481) In the "modern school," however, much more extensive work was done. Here there was a carpenter's shop where special attention was given to teaching the use of tools and simple work in wood. In the engineering

⁷Bennett, Charles Alpheus. *History of Manual and Industrial Education up to 1870*, p. 236.

shop, the boys were taught the use of metalworking tools and a few machines. "The following may be mentioned as having been made in the workshops: model engines in brass and iron, screws of various kinds, physical apparatus, book-cases, chests of drawers, sofas, tables, fishing punts, body of a pony carriage, tool chests, etc."

"Every boy in the school (except the highest divisions) is taught drawing." (8—V, 233)

Anyone who has learned of the classical requirements of the great public schools (schools to educate for public service) in England, such as Eton, Rugby, Harrow, etc., may be surprised that a school of this class, the Uppingham School, should have a place in the Report of 1884. As far back as 1862, instruction in carpentry began in this school. From 50 to 80 boys a year were in the carpentry classes; yet, in later years, it was not considered satisfactory from the standpoint of education, and so it was reorganized in 1882. In this year, as stated by the headmaster, Edward Thring, a class was formed "for the purpose of giving greater reality to the science teaching. The boys who joined were taught to make scientific apparatus of a simple kind, and then to experiment with it."

A small room was fitted up as a workshop, with a lathe and a couple of benches. The class was not a part of the regular school work, but was taken up voluntarily by the pupils. Attendance, when a boy had joined, was compulsory.

As the numbers promised to increase, it was considered advisable to engage an assistant to be constantly at work under the superintendence of the science master. A first-class mechanic was found, who had considerable experience in scientific instrument making. A larger room was fitted up and the classes grew in size.

In the spring of 1883, the carpenter's workshop was thrown under the same direction as the new scientific workshop. All the mechanical branches are now under the superintendence of the science master. (8—V, 55)

The following details, also taken from Mr. Thring's statement, indicate that some first steps, at least, had been taken toward an organized course of instruction in the use of tools:

There are two departments (in carpentry): a lower shop and an upper shop. In the lower shop, the boys begin with (1) tenon and mortise, (2)

toolbox, dovetailed, (3) cabinet door panelled, and so on. There is a certain amount of work set for each term. Boys who have completed this are allowed to submit a design to the teacher, and to work at it if approved of. Drawing is not obligatory.

There are two times of attendance in the week for each boy, during which he receives lessons. If he wants to work out of his regular time, he applies for a bench and, if there is one vacant, it is allotted to him. . . .

In the upper workshop, at stated times, lessons are given in cabinet-making. . . .

In the forge shop, the pupils make nails, brackets, hammerheads, etc. Forgings are made for the metal workshop; boys make their turning tools. When some familiarity with the work has been acquired, pupils are taught to make horse shoes and to fit them on a dead hoof; and, when they can do this, they are allowed, under careful supervision, to shoe horses brought into the forge. . . . Forge teaching is partly undertaken by the mechanical teacher from the metal shop, partly by a local blacksmith.

The metal workshop was started for the purpose of making scientific apparatus, but it has grown into a mechanical workshop for all kinds of work. Boys do not pass into it from the carpenter's shop, but can enter it without previous training.

The work commences with the forging and filing of a set of turning tools. Then an electric bell is made, which affords a variety of work, none of it of too difficult a nature. Opportunity is taken to interest the boys in the scientific facts connected with everything which they make, or see being made, and no trivial work is allowed, except by special permission out of work hours.

When the bell is completed, which generally takes more than one term, various pieces of apparatus are chosen to be made, such as a scribing block, a pump, an electric motor, or an induction coil.

Stress is laid on the boys learning to make and sharpen their own tools. They are required to make a drawing of the machine to be made. In this shop, a set of scientific instruments is being made for the use of the school.

Work is also being turned out for outside orders, and in every way the pupils are given to understand that they are admitted to a place in which real work is turned out, not to a place in which they can play with metal and tools. . . .

Boys who intend to take up the engineering profession are allowed more time at practical work, drawing, and mathematics during the last year of their stay than is laid down in the ordinary school course. Also, after leaving school, boys occasionally stay in the workshop for a special training to fit them for their further education in technical work. . . . The machinery consists of two Whitworth screw-cutting lathes, eight 5-inch lathes, one planing machine, vises, benches, etc. (8—V, 55 to 57)

A school quite different in character, the Allan Glen's Institute in Glasgow, was one of the earliest institutions to give shopwork a serious place in the curriculum. This school was established in 1853 as a free school for elementary educa-

tion; but, in 1876, by special Act, it became a school of secondary and technical education with a moderate tuition fee. It was intended for middle-class boys who wished to follow industrial, manufacturing, and mercantile pursuits.

One of the features of the school was the course in shopwork requiring four or five hours a day for two years. During this time, the boys received an equivalent of the first two years of apprenticeship to an engineer besides the instruction in mechanical drawing and other subjects. (8—1, 488)

In the shopwork, the material first used was wood. As long as the boys are "unable to work fairly well to measurement," said the headmaster, E. M. Dixon, at a conference in London in 1884, "the articles made by them are simple ones of their own selection, and become their own property upon payment for the material consumed. On the other hand, after a pupil has advanced to the point of being able to make a wooden model to scale, he begins to work for the institution, and regularly employs working drawings. He proceeds afterwards to work in metal, when, in the opinion of the principal teacher, he is able to take that step with advantage. As to the spirit with which boys go into their exercises in the workshop, I need merely say, it is what any person might anticipate who remembers the pleasure he had himself when young in working with tools of any kind." (9—IV, 905)

By 1883, a rather extensive course in practical shopwork had been developed at the University of Cambridge. Six workshops were made use of in training mechanical engineers—machine shop, erecting shop, smithy, foundry, pattern and carpenter's shop, and instrument shop. Quoting from Professor James Stuart's statement to the Royal Commissioners:

As to the practical work done in the shops, and the order of that practical work, we adapt this to the conditions of each pupil. They all begin for a short time on a definite job in the fitting and turning shop to familiarize them with the tools; and, in all cases, from the beginning of their course to the end, they are engaged on real practical jobs, and not on toy work, and have to turn out everything in a thorough, workmanlike manner. They work from drawings made by themselves, or similar to others which they have made or are about to make. . . . As we do a good deal of work for the University

and for others, there is always plenty of opportunity for the pupils to make designs, and we apportion that work among them in the way we find to be most educational. In fact, the place is an engineering workshop, where the work is arranged and distributed with a view to giving the pupils every facility for learning. (8—V, 147)

Some of the machines made in these shops were a shaper, lathes, a circular-saw bench, pattermaker's lathe, and small horizontal engines. In the instrument shop, electrical machines were made.

Among the other institutions mentioned in the Report of the Royal Commissioners as giving instruction in shopwork were King's College, London, Finsbury College, The Royal Indian Engineering College, and the Manchester Technical School.

At King's College, students went through "a series of exercises in mechanical work," and it was stated that the full course given would shorten apprenticeship by two years. "The carpenter's and mechanical shops and smithy are open under certain regulations to the boys from the school attached to the college. In the joiner's shops, they learn to make the common joints of carpenter's work and the fitting of doors and windows; whilst, in the engineers' shop, they learn wood and metal turning, chipping, filing and surfacing." (8—I, 396)

At Finsbury College, a carpenter's shop was equipped with benches and lathes, and a machine shop with vises, lathes, and other tools for benchwork in iron. (8—I, 409)

The Royal Indian Engineering College, Cooper's Hill, was provided with a workshop containing "lathes and small machine tools driven by a steam engine," also "a small carpenters' shop principally used for patternmaking." (8—I, 414)

In the year 1883, as the result of a reorganization of the Manchester Mechanics Institution, the Manchester Technical School came into being. In this school, there was provided a mechanical engineering shop, which was equipped with a gas engine, a lathe, a slotting machine, a grindstone, 12 vises, etc. (8—I, 432)

In 1885, there was started in Manchester Technical School

a manual training school "for boys of 13 years and upwards, on lines similar to those of the Manual Training School of St. Louis, Missouri." (10—I, 5) This had come about through William Mather (later, Sir William Mather) (1838–1920), a manufacturer in Manchester, a member of Parliament, and also a member of the Royal Commission on Technical Instruction. In his capacity as Commissioner, he had visited Russia and the United States of America. In America, he was very favorably impressed with the type of manual-training school that had been developed by Professor Calvin M. Woodward of Washington University, St. Louis. In 1884, Mr. Mather invited Dr. Woodward to come to England to speak at an International Conference on Education held in London and, a few months later, at a conference in Manchester. One result of these conferences was the opening of the manual-training school in connection with the Manchester Technical School.

The fundamental teaching idea in the St. Louis school had come from the system of class instruction in the use of tools devised by Della Vos at the Imperial Technical School at Moscow, Russia, and shown at the Centennial Exposition in Philadelphia in 1876. Thus it came about that the analysis of tool processes which was the foundation of the Russian system (cf. 1), became in turn the basis of the tool instruction at the St. Louis Manual Training School and in the manual-training work of the Manchester Technical School. (10—I, 5)

In the report of the Manchester Technical School for 1890, there appeared the following:

Now that manual training is receiving that public appreciation which it so much deserves, and for which it has hitherto so vainly struggled, it is of some importance to recognize the fact that this is the first school in the kingdom to embrace it as an organic part of a boy's education, to be carried on side by side and in close coordination with other more purely literary studies. Its success is not to be measured by the comparatively small number of boys who have been enrolled, but by the stimulus and example it has afforded and the conclusive proof it has given that not only can manual training be readily arranged so as to form part of a boy's instruction, but that it is absolutely essential to a full development of his faculties. . . .

The results have fully justified its maintenance and continuance. It has,

in numerous instances, helped to determine the pupils' aptitudes and fix their careers. Many who, under ordinary circumstances, would have simply swelled the overstocked ranks of clerks and warehousemen, have, under the stimulus and training they have received, entered upon some business where manual skill and dexterity are essential conditions of success. . . . It is a matter worthy of note that had these boys, during their previous school career, had some such hand-and-eye training as is implied by a carefully graduated kindergarten course, they would have been in a much better position to profit by the subsequent training in this department. (11—390)

49. Shopwork Begins in Board Schools. Sheffield has been given the credit of being the first to organize what in England is called a Central School. This is a school made up of the brightest or specially talented pupils from the other elementary schools in the city or district. Such a school is intended to give instruction that is much better suited to the needs of the pupils selected for this school, and at the same time improve conditions in the schools from which they come. Pupils who have passed the fifth standard, or about eleven years of age, may be selected for the Central School.

In the year 1880, the first school of this type was established. The science master in this school was W. Ripper, later Professor Ripper, head of Technical Department, Sheffield University. In order to make his science instruction more interesting and more effective, he induced the School Board to fit up a shop for work in wood and iron, including in the equipment a lathe and a forge. The workshop instructor was Joseph William Baily, a skilled craftsman and "clerk of works to the Sheffield School Board." He was the uncle of James T. Baily, secretary of the National Association of Manual Training Teachers in 1908. The instruction in this shop began by requiring the students in geometry to make geometrical forms out of wood. Later they were made out of metal. Each student was required to make a working drawing of the object he was to make in the shop. (10—VII, 124)

In the report of the Royal Commissioners, 1884, Mr. Ripper's shop instruction was outlined as follows:

The production of simple but perfect geometrical forms in iron and wood, such as the cube, hexagonal prism, etc., to teach accuracy of work and skill in the use of tools.

The construction of models in wood, suitable for use in schools, as examples for model drawing.

The construction of simple apparatus to illustrate by actual experiment the principles of levers, of levers in combination, pulleys, wheel and axle, the crane; strains on beams with different positions of load; the mechanics of the roof, arch, bridge.

The more advanced pupils will be taught to construct apparatus for the purpose of illustrating the lessons given in machine construction, applied mechanics, building construction, and mechanical engineering. All the models to be made from working drawings prepared by the students.

The aim in the above class will be to give a systematic course of practical instruction in the science of mechanics. (8—III, 561)

The boys willingly come an hour before the ordinary time for opening school, and they are occupied in the workshop two hours per day. The eagerness with which they engage in this work seems to add to the interest of other studies, and there can be no doubt as to its ultimate usefulness. (8—III, 563)

It is not sought to apply it to any particular trade, but to give the kind of knowledge and practice that will be useful in whatever trade he may be brought up to. (8—III, 559)

In the year 1883, the School Board of Manchester arranged to give instruction in the use of tools in two elementary schools. Benches, sets of tools, and lathes were purchased. A joiner employed by the Board was delegated to "superintend the boys at work," and a special teacher gave the lesson. According to the report of the Royal Commissioners of 1884, two boys worked at each bench. Boys in the fourth standard or above worked $1\frac{1}{2}$ hours each week and a lesson on tools and materials was given one hour a week. A part only of the time was taken out of the ordinary school time. It was reported that the boys liked the work very much, and that parents appeared to be interested. In a few instances boys had brought wood to use, making some special things to take home. (8—V, 153)

F. C. Montague, in discussing this work in Manchester in 1887, said, "All that can be done is to give the scholars a chance of making themselves acquainted with the common tools of working wood and iron. Such knowledge is useful to them, even if they do not afterwards become artisans." (12—22)

In 1884, the School Board of Birmingham established a school known as the Bridge Street Seventh Standard Tech-

nical School. This was for boys who had passed the sixth standard or an equivalent examination and were destined for industrial pursuits. In this school, the subjects taught were mathematics, drawing, and science, and three hours a week were spent in shopwork. (13—IV, 372)

While this early experimental shopwork was beginning in Sheffield and Manchester and Birmingham, the need for



FIG. 83. WORKSHOP, BEETHOVEN STREET SCHOOL, LONDON

similar work was being felt in at least one elementary school in London. John William Tate, headmaster of the Beethoven Street School, Chelsea, was in the habit of finding situations for the boys and girls who had completed the work in his school in a creditable manner. In doing this kind of guidance and placement work, he was aware of the fact that most of the boys were going into offices as clerks or bookkeepers or into stores. He realized that this was so because the instruction in the school came nearer fitting a boy "for the desk or the counter than for the workshop." It occurred to him that he could remedy this if he had a workshop in

which practical instruction could be given to the boys during the last year of their course in the school, which was the seventh standard. As the caretaker (janitor), J. T. Chenoweth, was a carpenter by trade, perhaps he could help in working out such an idea. Mr. Tate then proposed to the management committee of the School Board that a roof be built over a corner of the playground and the space be used as a shop. This was done; a few tools were purchased to add to those loaned by the caretaker; lumber was procured; and, in September, 1885, thirty boys were selected to do this new kind of school work, Fig. 83. Once each week, in one of the classrooms, the caretaker would demonstrate the character and use of the tools. For shop practice, the class was divided into two sections, each of which worked in the shop a half day a week. On this plan, they worked for months, making carpenter's benches with wooden-screw vises, cupboards for materials and finished work, racks for tools, hat pegs, and shelves for general use.

Many years after these early experiences, Mr. Tate said:

The lads took to the work as ducks take to water. It was most popular. Even the caretaker acquired a new dignity; he possessed a knack which they lacked; he was looked up to in a way that he had never been before. Meanwhile, I began making myself a bench and bought a new set of tools, and attended several courses of lectures and demonstrations with workshop practice at the City and Guilds of London Institute, thus qualifying myself for supervision of what I saw was proving an absorbing and interesting experiment. The boys who longed for the time when they should leave school and dress as gentlemen and go to the City, began to have new and enlarged views of life and the dignity of labor; and enjoyment in work and production took hold of their minds, especially when they saw several of the class masters eagerly bent in the same direction and working out of school hours in the workshop, which, whenever the door was unlocked, became a rendezvous for the favored elder boys who were privileged to enter its portals. I may say here that we never had the slightest difficulty with discipline. If a boy in the fullness of spirits was too exuberant and troublesome, it was enough for me to say to him that he had made a little mistake, that this was a workshop not a play-shop, and that, if he could not realize that fact, there were many boys eagerly waiting who would gladly fill his place. This always had the desired effect of sobering the boy, and I never remember having to go further. . . .

After the workshop was fully fitted, we had to devise some other work for practice, and, in this, it was necessary to exercise economy and spend as little money as possible. I therefore thought we had better make articles such as

could be used in schools generally. We made pen trays, boxes to hold 12-inch flat rulers and compasses, and a large box which we called a needlework class box. It was an oblong box with four divisions fitted in the lower half, over which was a loose tray and a deep lid held in place by the sides of the tray. This we made for each of our classes, and its handiness consisted in box, lid, and tray being each capable of use to distribute or collect quickly the needlework material at the beginning or end of the lesson. These articles, when we had supplied our own wants, were sent to the Board offices by their carman, and a price for each, which had been previously agreed upon, and which was estimated upon the amount of timber used, allowing for waste, was paid; and they were sent for use in other schools. The money thus received enabled us to buy more timber and keep the work going. . . .

Where we failed was in the want of connection between the school drawing lesson and the workshop, the economy forced upon us by circumstances, the spirit of commercialism introduced (which link eventually snapped), and the lack of carefully graded exercises. But, for all this, I am proud of our early attempt, and I am sure that we smoothed the way for the big advance made later. (14—VIII, 124, 125)

For nearly two years, this work at the Beethoven Street School had no rival in the elementary schools of London. Being in the metropolis, it attracted the attention not only of Board members and members of Parliament but also distinguished educators from other countries. It was considered a success. It pointed the way for future development.

While this shopwork was done by elementary-school boys, it hardly deserves the name "manual training," the term which, even at that time, through the efforts of Dr. C. M. Woodward of St. Louis, had come to be a term applied specifically to shopwork or other manual work which was based on tool-process analysis of some trade or craft, and was organized so that the elements could be taught as exercises in the order of their difficulty of execution. Neither does it deserve the term "sloyd," which involved a similar analysis and the organization of elements into a course of instruction consisting of useful articles. It was, however, shopwork, in which the motive was not preparation for one specific trade, but to give some general industrial ability, and especially to lead boys toward industrial pursuits.

Payment for the cost of the shopwork instruction in that first year's experiment at the Beethoven Street School was not allowed by the Local Government Board because shopwork was not regarded as a subject of instruction under the

existing Code. This decision prevented the opening of five additional classes in shopwork which had been sanctioned by the School Board. (6—48)

50. The Development of the Manual-Training Idea. Each year after 1885 saw an increasing interest in more definitely industrial training in the elementary schools. In the Report of the Royal Commissioners of 1884, there had been this important statement:

Your Commissioners have had the opportunity of inspecting the manual work of the pupils both at the Manchester Board schools and at the Central School in Sheffield, and they are satisfied that such work is very beneficial as a part of the preliminary education of boys in this country who are to be subsequently engaged in industrial pursuits; even though it should not, as, however, it probably will do, actually shorten the period of their apprenticeship.

Your Commissioners see no reason why, since grants are made on needlework in girls' schools, they should not be made on manual work in boys' schools. This instruction may be given so as not to interfere with the ordinary work of the school. It has been proved that this can be done, the boys being most eager to return for handicraft teaching after school hours. (8—I, 524)

Later in the report, the Commissioners definitely recommend that "proficiency in the use of tools for working in wood and iron be paid for as a 'specific subject,' arrangements being made for the work being done, so far as practicable, out of school hours." (8—I, 537)

It should be noticed that the reasons given by the Commissioners for manual work as one of the special subjects in the elementary schools was that it would be beneficial to boys who meant to follow industrial pursuits. It would shorten their apprenticeship. Moreover, it should be noticed that it was not recommended for all boys.

In 1886, the current of thought was changed very materially by an article on "Manual Instruction" in the *Fortnightly Review*, written by Sir John Lubbock, afterwards Lord Avebury (1834-1913), the famous naturalist. He said that it seemed to him that it was just as reasonable to teach boys to use tools men work with as it was to teach girls to do needlework. He would introduce "carpentering or some-

thing of that sort which would exercise the hands of the boys as well as their heads." And then he added:

The introduction of manual work into our schools is important, not merely from the advantage which would result to health, not merely from the training of the hand as an instrument, but also from its effect on the mind itself. (15—XLVI, 467)

There have been two very different points of view from which manual instruction has been recommended. The first looks at the problem from a specially economical point of view. The school is arranged so as to elicit the special aptitudes of the pupils; to prepare and develop the children as quickly and as completely as possible for some definite trade or handicraft, so as to, if possible, assure them, when leaving school, the material requisite for existence. In this way it is maintained that the wealth and comfort of the nation can be best promoted.

The second theory regards the manual instruction as a form of education; the object is to give to the hand, not so much a special as a general aptitude, suitable to the varied circumstances of practical life, and calculated to develop a healthy love of labor, to exercise the faculties of attention, perception, and intuition. The one treats the school as subordinate to the workshop, and the other takes the workshop and makes it a part of the school. The one seeks to make a workman, the other to train up a man. (15—XLVI, 469)

This article was followed a few months later by one in the *Contemporary Review* entitled "Manual Training in School Education" written by Philip Magnus (later Sir Philip Magnus) (1842–1933), director of the City and Guilds of London Institute. Emphasizing the claims of Sir John Lubbock, Mr. Magnus said:

"It cannot be too often repeated that the object of workshop practice, as a part of general education, is not to teach a boy a trade, but to develop his faculties and to give him manual skill; that, although the carpenter's bench and the turner's lathe are employed as instruments of such training, the object of the instruction is not to create carpenters or joiners, but to familiarize the pupil with the properties of such common substances as wood and iron, to teach the hand and eye to work in unison, to accustom the pupil to exact measurements, and to enable him by the use of tools to produce actual things from drawings that represent them. (3—L, 697)

This article supplemented the article by Sir John Lubbock because it answered specific objections to the introduction of manual training into elementary schools, cleared up misunderstandings, and discussed in considerable detail questions of equipment, supplies, teachers, and expense. Mr. Magnus gave facts concerning such instruction in the elementary

schools of Continental Europe and insisted that manual-training instruction should be subject to a grant from public funds. He gave what he considered proof that a child's literary education would not suffer by devoting a part of the regular school time to manual instruction.

51. Manual Training in London under the "Joint Committee." As previously stated (cf. 49), the Government Board had refused to allow public funds to be used to pay for instruction in woodworking, although such funds were allowed for instruction in sewing and cooking. The reasons given were that woodworking was not included in the Code and that there was no authority for such expenditure. Although the validity of these reasons was questioned, most school boards did not care to take the risk of a surcharge. (13—IV, 374)

In an effort to carry forward the experiment already begun successfully, the School Board for London, early in 1886, addressed a letter to several of the wealthy guilds of London and to the City and Guilds of London Institute supported by them, asking for help in maintaining instruction in certain trades. The Drapers' Guild came forward promptly and promised £1,000 toward the expenses of the proposed experiment. The City and Guilds of London Institute, however, led by its director, Philip Magnus, advocated manual training as "a school discipline" and not as instruction in the technic of a special trade. At about this same time, the School Board appointed a committee, under the chairmanship of William Bousfield, to make a study of the subjects and methods of instruction in the elementary schools of London. This committee, among other reforms, recommended:

(1) That manual work be always taken in connection with school teaching of underlying science and of drawing.

(2) That no special trade be taught. (1—148)

In May, 1887, the City and Guilds of London Institute proposed that representatives of the School Board meet a group of their members to consider a plan for equipping four schools for woodworking and maintaining them for one

year. This meeting resulted in the appointment of a joint committee of eighteen members, nine from the School Board and nine from the Guilds. The School Board agreed to allow the Committee the free use of such rooms as were needed for the new work, and the Guilds agreed to provide the £1,000 promised by the Drapers to pay expenses. (6—49, 15) (Source Material, VII A)

The Joint Committee selected six centers instead of four, as originally proposed. These were in school buildings, three north of the Thames and three south. A conference of headmasters of nearby schools was called, which resulted in securing their interest and cooperation in planning details of organization and obtaining the right students. In the Committee, there were differences of opinion concerning the kind of teachers needed, some maintaining that they should be skilled craftsmen and others that they should be skilled teachers. The controversy was settled by the decision to appoint two instructors, one of whom should be an assistant schoolmaster who had been trained in manual work, and two assistant instructors, both of whom should be practical workmen. In the customary way, the positions were advertised in the leading newspapers and thirty-two applications were received. From these the Committee selected as instructors John C. Pearson, assistant master in a Board school, and Solomon Barter, an expert cabinetmaker and a teacher of experience in science and art classes. For assistant instructors, they appointed C. W. Boxall to work with Mr. Pearson and A. Whillier to work with Mr. Barter. (6—51, 52)

After considerable discussion, it was decided to have the boys come to the manual-training center for a half day each week, and instruction began in January 1888. The success of this plan through the years has proved the wisdom of this early decision. An instructor, an assistant instructor, and thirty boys were at one of the centers north of the Thames each half day, and a similar number at one of the centers south of the Thames. Thus 120 boys were taught each day, or 600 a week. (6—52)

The Joint Committee did not attempt to formulate a

course in detail, leaving that to the instructors. They did, however, prepare the brief syllabus given in Source Material VII A, to serve as a suggestion. The Guilds continued their support for a second year and the syllabus was then very much expanded. During these two years, the manual-training classes were visited by many men and women interested in the problems of education, and the general concensus of opinion was that the experiment had "succeeded beyond the expectations of the most sanguine. It was shown that the instruction stimulated the intelligence, and improved the physique of the children; that the discipline was pleasant to the learners; and that, whilst it gave reality to much of the abstract teaching of the school, it endowed the young workers with manual skill and adroitness which remained with them a permanent possession for life." (1—149)

At the end of the second year, December, 1889, Mr. Pearson resigned to undertake the organization of similar work in Liverpool, and his assistant, Mr. Boxall, accepted an appointment in Sheffield. Mr. Barter was then given the title of organizer and placed in charge of the six centers established by the joint committee. Meanwhile, an urgent demand had developed for including manual training in the Code of the Government Board of Education. Late in 1889, the Technical Instruction Bill was passed, permitting the use of public funds to aid manual instruction in secondary and technical, but not in the elementary, schools. (16—137) The following year, however, the new Code included regulations for the teaching of woodwork in elementary schools under conditions which would allow a money grant to be obtained from the Government. (1—149) In referring to this action, Sir Philip Magnus said, "Never, perhaps, was a revolution so scientifically effected, and so clearly the result of carefully prepared experiment, as that which gave to manual instruction a prominent place in our system of elementary education. Since then the joint committee has done other good work; but its successful endeavor practically to establish the fact that manual training may, with advantage, be substituted for some part of the instruction, which had previously occupied

nearly the whole of school time, is a real educational gain, and will give to the committee the right to be remembered among those who have largely contributed to the improvement of our system of elementary education." (1—149)

The Board of Education and the School Board of London were now definitely committed to the policy of stimulating the growth of manual instruction in elementary as well as secondary schools. As early as November 1888, the London School Board passed the following resolutions concerning rooms for the use of manual training:

That as opportunity offers, accommodation shall be provided in connection with Boys', Girls', and Senior Mixed Departments in which instruction in manual and other practical work shall be given.

In order to give effect to this resolution, the Committee have instructed the architect of the Board, when submitting the plans of a school, to report whether any special accommodation can be provided in connection with it. (7—21)

52. The Early Influence of Swedish Sloyd. Meanwhile, what was destined to become an influential factor in the development of British manual instruction, the Swedish sloyd, was seeking a foothold with the other types of shop-work in the schools. As early as 1884, two English women teachers went to Sweden and took a summer course in sloyd under Herr Salomon. Many other teachers, both men and women, followed in succeeding years. They usually returned full of enthusiasm for the Swedish system. In 1887, a three-months' course in sloyd was taught on Saturday mornings at the Medburn Street Board School, St. Pancras, London, by Miss Clarke, headmistress of the Infants' Department of that school. Both boys and girls were in the class. It was discontinued because no funds were available to pay for the instruction. (6—56)

Private enterprise, however, continued to come to the assistance of the teaching of sloyd. Social workers and educators who were afraid of the "carpentry" often approved of the sloyd because of the statements concerning it formulated by Herr Salomon. They were opposed to teaching trades in the Board Schools, and especially opposed to turn-

ing out what they feared might be an over-supply of carpenters; but they were readily convinced that sloyd was not a trade in England, that it would not produce too many carpenters, and that it was educationally sound.

The pleasant summer experiences of the teachers who went to Sweden stimulated a loyalty to the Swedish ideas that, in some cases, was very superficial, seeking merely to transplant or adopt Swedish sloyd, rather than to produce an equally educational system that harmonized with British tool practice and British social and industrial life. This resulted in two more or less opposing organized groups of teachers and promoters of manual instruction, which continued a long time—one looking to the City and Guilds of London Institute for approval, and the other, at first, to the Sloyd Seminarium at Nääs, in Sweden, and later to the leaders of their own group in Britain.

While some of the teachers who went to Sweden to study returned with a desire to teach as they were taught, even to copying the Swedish models, others brought back the true spirit and educational method of the sloyd. These latter ultimately became the leaders of the sloyd group of workers in Great Britain.

One of the early and far-reaching results of importing Swedish ideas took place in London: George Ricks, senior inspector for the School Board of London, suggested "the introduction of a modification of the Nääs sloyd into the woodwork classes conducted under the joint auspices of the City and Guilds of London Institute and the School Board of London." (17—VII). This suggestion was carried into effect by Mr. Barter, the organizer, and resulted in what he called "The English Sloyd." This system of manual training was published in book form under the title *Woodwork* in 1892. From one viewpoint, Mr. Barter's course was a three-way compromise: It included exercise pieces and joints comparable to those taught by the City and Guilds of London Institute. By way of application of these exercises, it adopted the idea of making useful articles, which was insisted upon by the Swedish sloyd; and it accepted the requirements of

the Science and Art Department that the making of an object should be preceded by the making of a working drawing of it. If a fourth item were added to these three, a detailed study of timber and tools, the most obvious characteristics of Mr. Barter's course would be evident. While these characteristics were important at that time, the greater permanent value of the book was in presenting many practical teaching details, and making them clear by numerous illustrations. It set forth certain methods of procedure in teaching the fundamental processes of woodworking which had been tested by experience. To that extent, it was an epoch-making as well as a pioneer book in England.

The year following the publication of Mr. Barter's book, 1893, two others appeared. One, by William Nelson, organizer of manual instruction under the Manchester School Board, was entitled *Woodwork Course for Boys*. This consisted of thirty exercise pieces and useful models and was intended to cover the requirements of the Science and Art Department. It consisted of working drawings and with each a list of the steps in the construction of the object. Several of the models in this course were taken directly from the sloyd course at Nääs, though more of them were typical joints and exercise pieces found in technical school courses. The other course published that year was *Woodwork* by J. C. Pearson, director of manual instruction in the board schools of Liverpool. This was an eclectic course, including exercise pieces from the Technical School at Manchester, geometric solids from the course devised by Professor Ripper at the Sheffield Technical College, sloyd models from Sweden, several pieces of science experimental apparatus, common joints used in woodworking, and other useful articles. Among the other early books were *The Grammar of Woodwork* by Degerdon of the Whitchapel Craft School, *Hand and Eye Training* by George Ricks, and *Hand-Craft*, consisting chiefly of the Swedish sloyd models, dimensioned in feet and inches, by John D. Sutcliffe.

53. **Sloyd Efforts to Gain Official Recognition.** During the years from 1890 to 1898, the greatest handicap to the

free development of manual training in England was the conflict of ideals and purposes of the two departments of the Government Educational Council—the Science and Art Department, and the Education Department. In 1898, these two were merged, forming the Board of Education. As previously stated (cf. 51), the Code passed by Parliament in 1890, regulating State-aided instruction, included “manual exercises” as a part of public elementary education. These manual exercises, according to the explanatory circular issued as a guide to school inspectors, were regarded as a “continuation of the employments of the kindergarten, and graded in difficulty.” One statement in the circular read thus: “Such exercises sometimes consist of modeling, the cutting, fixing, and inventing of paper patterns, the forming of geometrical solids in cardboard, and the use of tools and instruments.” (18—231) It is evident from this statement that the intention of the writer of this circular was to encourage the development of a comprehensive scheme of handwork instruction beginning with the kindergarten and extending up through the seven standards of the elementary schools.

From the administrative standpoint, the effect of the new Code was to allow instruction in the manual arts to be maintained out of the ordinary board school funds, which included the local board school rates (taxes) and the funds available from the national treasury. Voluntary or denominational schools could obtain the latter but not the former. Previously no part of the school funds could be used for manual training. The interpretation of the Code placed the responsibility for the administration of the section referring to manual instruction, so far as the Government was concerned, in the hands of the Science and Art Department, which was in charge of technical, science, and art education. This department forthwith announced that manual instruction, to be State-aided, must be “(a) in the use of ordinary tools used in handicraft in wood and iron; (b) given out of school hours in a properly fitted workshop; and (c) connected with instruction in drawing; that is to say, the work must be

from drawings to scale previously made by the scholars." In this case, "out of school hours" was intended to mean time not included in the minimum of twenty hours per week to be given to the teaching of other subjects included in the Code. It was further provided that the scholars must have passed the fourth standard and must receive manual instruction for at least two hours a week for twenty-two weeks during the school year. (18—232)

These regulations, covering a field so much more restricted than was originally intended and, even within the realm of the shopwork, so indefinite, led to misunderstandings and a conflict of ideas. The Science and Art Department was so much interested in technical education that it could not catch the full significance of manual training as a vital factor in elementary education. It could tolerate the system developed in London but it was not ready to accept what was being done in the name of sloyd. This technical-school viewpoint continued to be a thorn in the flesh of sloyders and other innovators who were trying to make the manual training of the Board schools more broadly and richly educational. Meanwhile, the Education Department was trying to encourage work in the manual arts suitable for the lower standards. As previously stated, in 1898, the Science and Art Department and Education Department were united to form the Board of Education. With this action came a welcome change in the method of granting funds for the support of manual training. Taking the place of the examination system were four inspectors of manual training, each assigned to a district. These men went from school to school and made their recommendations for money grants according to what they found taking place in the schools and upon records of attendance. Instead of what was termed the "pernicious system of payment by results" determined wholly by technical standards, the new system evaluated manual training according to its general educational results; yet, at the same time, it endeavored to stimulate a high standard of technical performance. Under these new conditions, the shopwork instruction enjoyed greater freedom of develop-

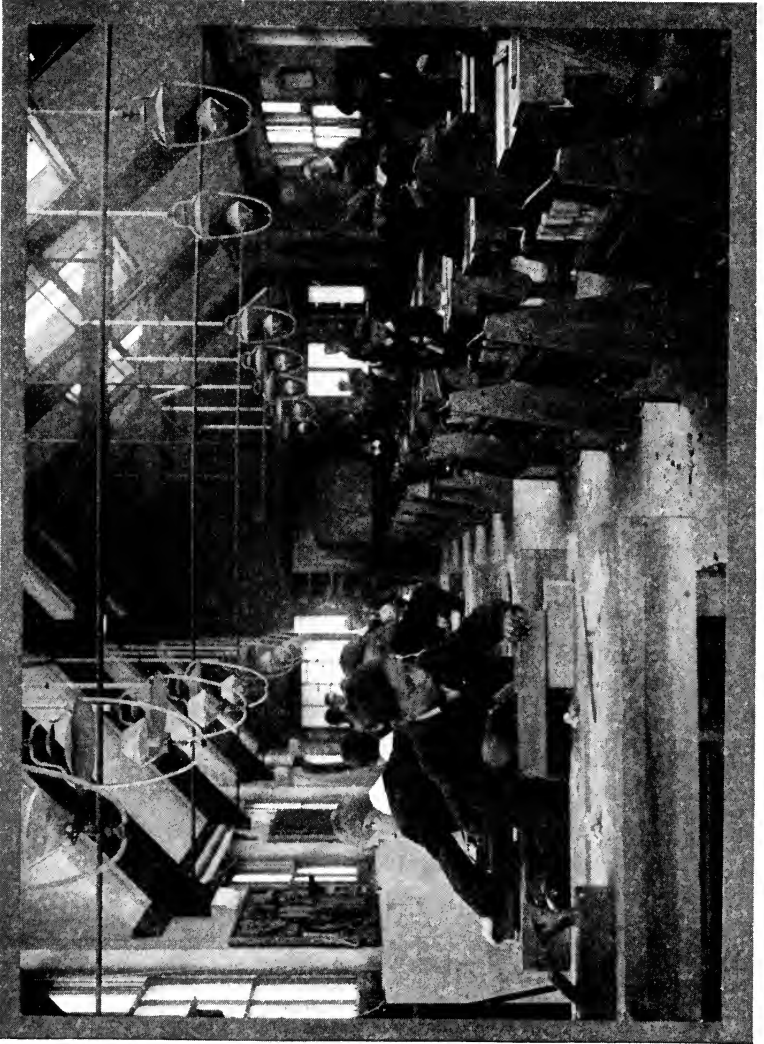

FIG. 84. KENNINGTON ROAD CENTER, LONDON

ment. While this was taking place, several different types of simple handicraft were being introduced into the lower standards "to bridge the gap between the kindergarten activities of the infant school and the shopwork of the two upper standards of the elementary schools."

54. Typical Equipments and Courses of Instruction. As might be expected from what has been said already about the various sources of ideas in the early development of manual training in England, the equipments differed very much, and hardly any two courses of instruction were alike. Nevertheless it is possible to select certain schools whose courses and equipments are more characteristically English than certain others. For example, the Kennington Road Center, Fig. 84, in 1909, was a typical London center. At that time it was new and embodied the recent idea of the supervisory staff. It was a separate structure with light from six directions—four sides and two rows of skylights. There were also gas lights for evening work. It contained two rows of double benches with a row of double tool racks between. The extra tools were in wall cabinets. The room accommodated forty pupils and was provided with two teachers—a head teacher and an assistant. There was a portable blackboard at each end of the room so that there need be no interference if both teachers wished to give a demonstration at the same time. For most purposes, the class was divided into two sections of about equal size. To this center came two classes a day, one in the forenoon and the other in the afternoon.

On one of the walls of this room was a board upon which were mounted, in the order of procedure, the exercise pieces and models representing the course of instruction, Fig. 85. This course covered about three years of work. The first six exercises were required of every pupil and were the same in all the London centers. If the teacher considered it desirable to modify any of them to meet the needs of dull pupils, he must obtain the permission of his supervisor. These six, which involve the first use of the fundamental tools, constituted the foundation upon which the rest of the

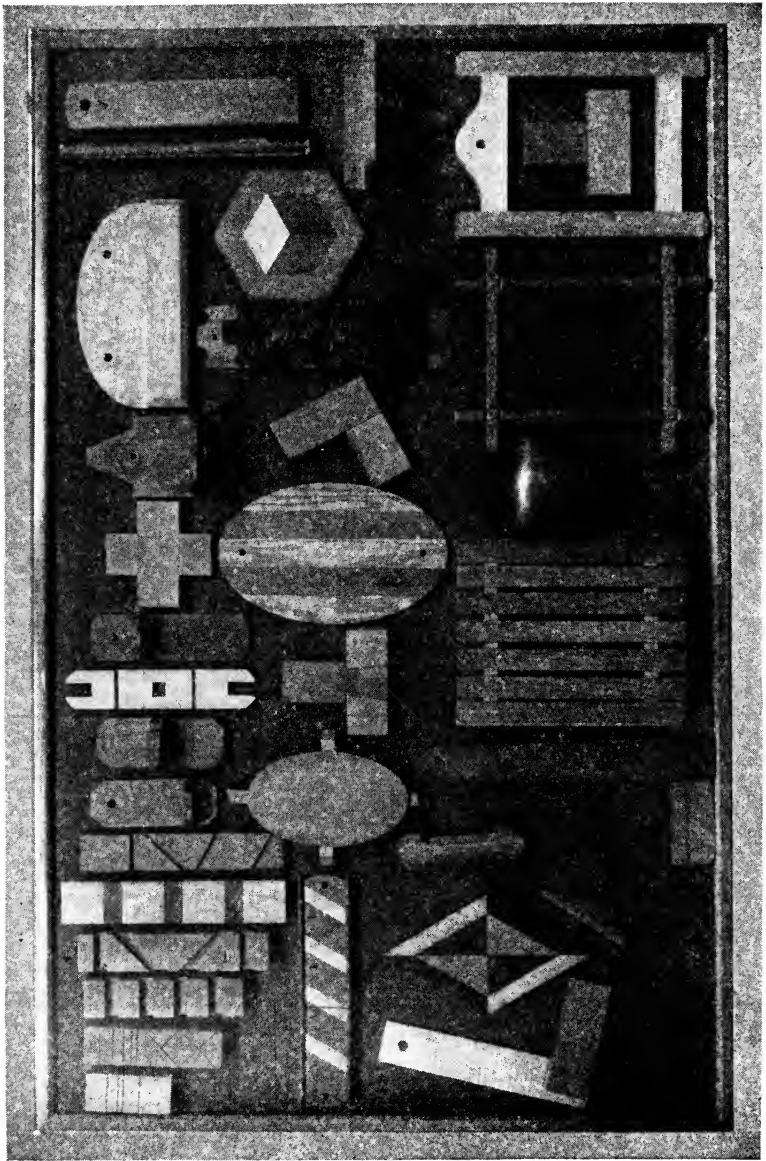

FIG. 85. MODELS IN COURSE AT KENNINGTON ROAD CENTER, 1909

course was built. From that point on, the instructors were free to suggest models of their choice for the approval of the supervisor, provided that the operations and the order of taking up the various tools followed substantially that of the course approved by the supervisor, Mr. Barter, which was a modification of the course given in his book on woodwork. (17—139 to 328) The course recognized the principle of "alternate models," but, generally speaking, each boy in a given school made the same things as every other boy. (19—XI, 10, 11)

Another equipment fairly typical of schools pursuing a course developed more directly from the Swedish Sloyd was the center in the City of Leicester, shown in Fig. 86. Here was a room with high ceilings and large windows high up from the floor, affording good light. The room contained ten double benches of the cabinetmaker type. A closet for tools was under each bench and extra tools were in tool racks on one of the walls of the room. On the walls were also charts, models, and samples of wood. At one end of the shop a door opened into an exhibit and storeroom. (19—XI, 214)

The course taught in this center in 1809 is shown in Fig. 87. It consisted entirely of useful models. The pupils came from the sixth and seventh standards and worked in the shop an hour and a half each week. The instruction was individual, there being no class demonstrations.

In certain districts in England, where metalwork is prominent in the industries, a part of the manual-training work was done in iron instead of wood. The equipment for metalwork usually involved a forge, one or more foot-power lathes, a bench drill, and a bench shear. In 1909, such a center in Birmingham, Fig. 88, contained four foot-power lathes, three small upright drills, worked by hand, two forges, two anvils, a grindstone, three surface plates, bench shears and three saw gummets worked by hand. The drawer at each bench contained: inside calipers, outside calipers, try square, spring dividers, cold chisels (one of them a cape chisel), scriber, straightedge, 30° set square (triangle of steel), 45°

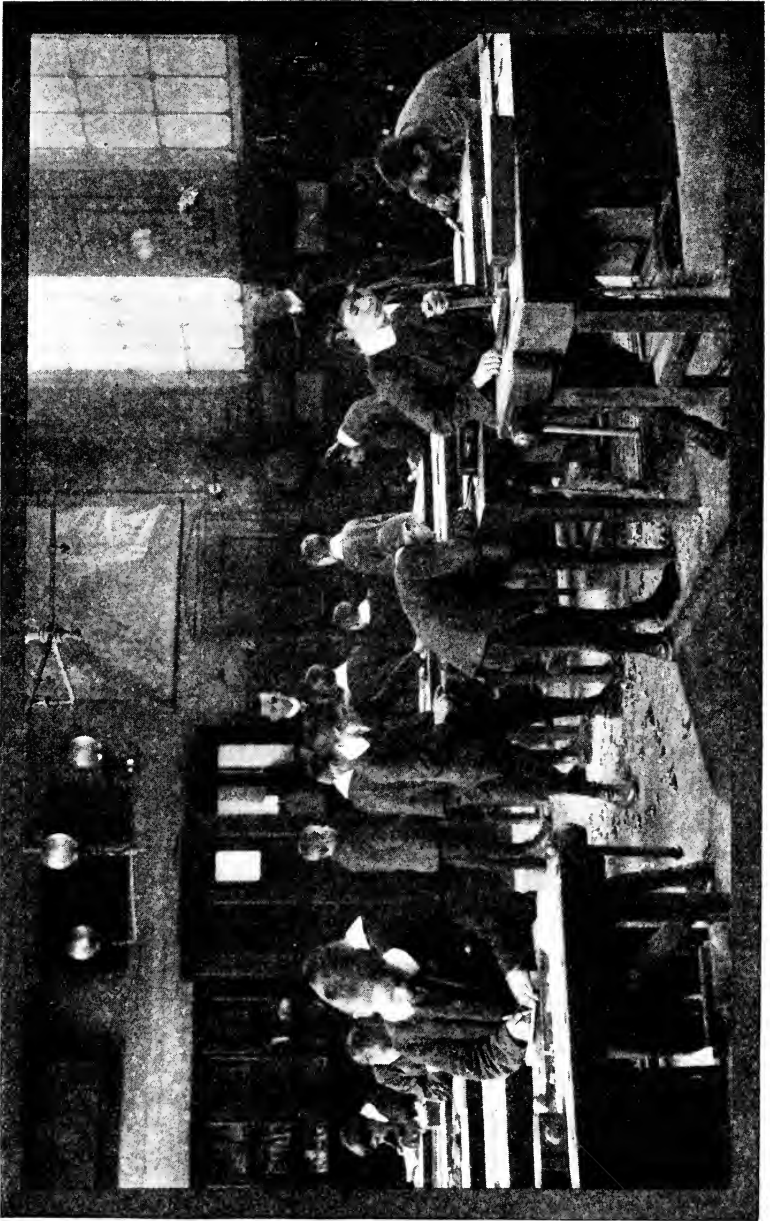

FIG. 86. WORKSHOP IN LEICESTER

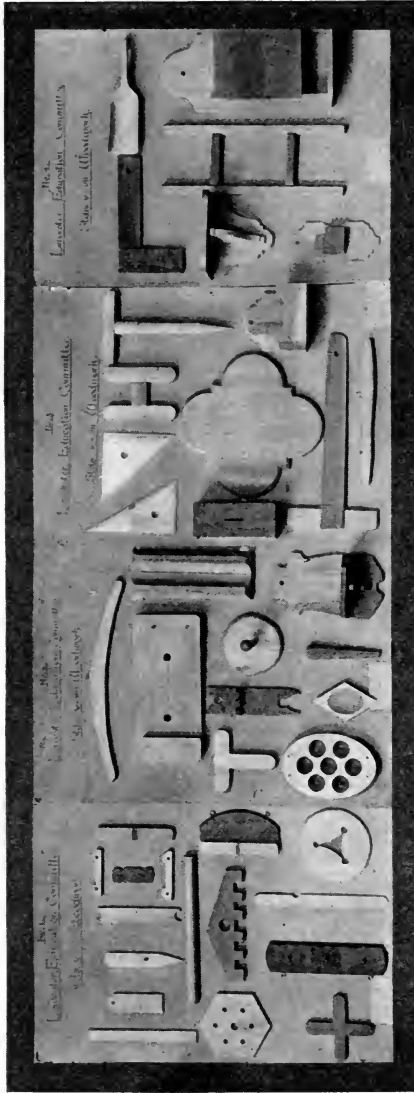

FIG. 87. COURSE IN WOODWORK FOR ELEMENTARY SCHOOLS. LEICESTER, IN 1909

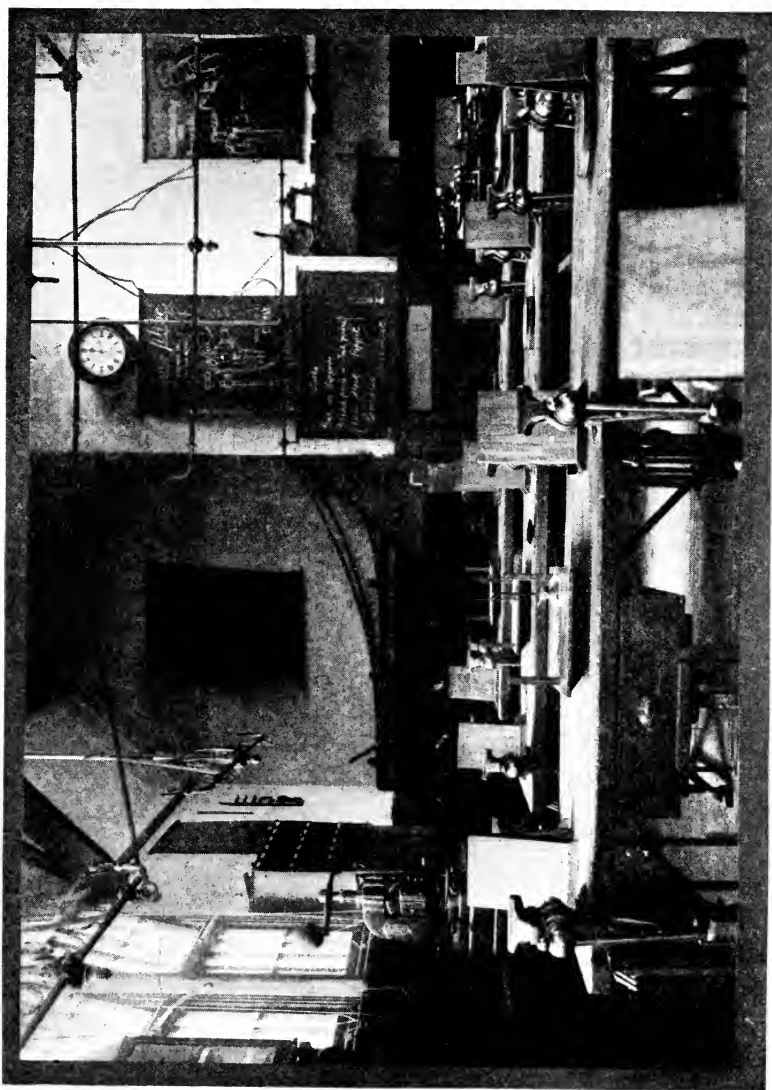

FIG. 88. METALWORKING CENTER, BIRMINGHAM

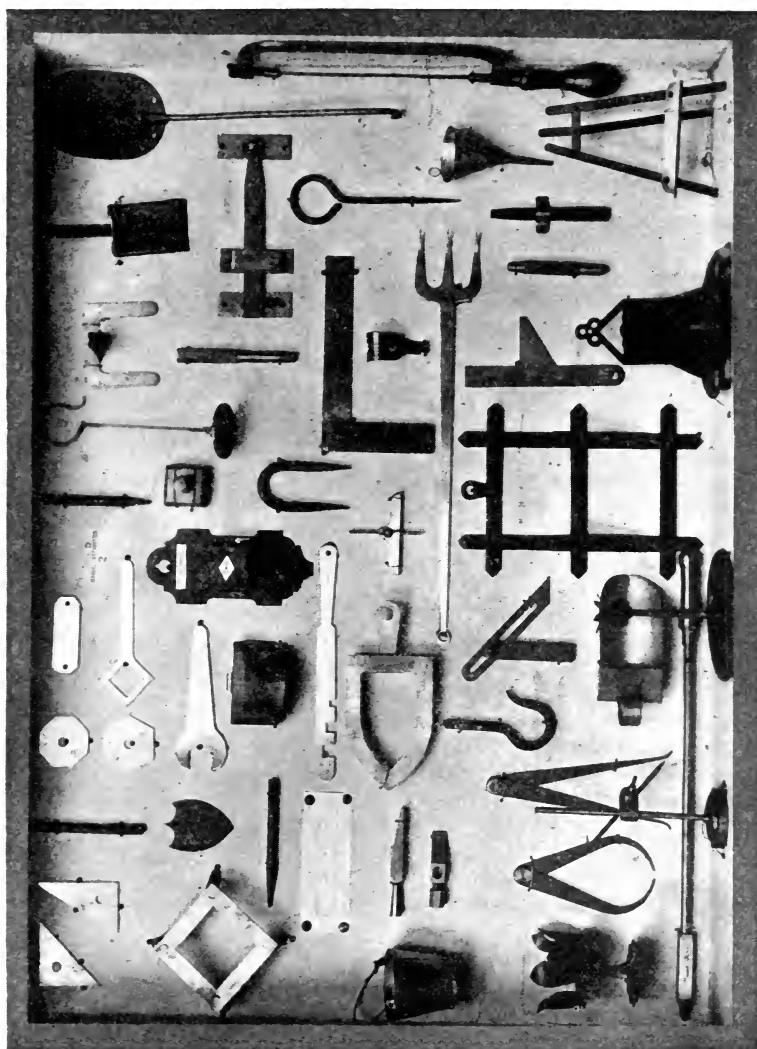

FIG. 89. ELEMENTARY-SCHOOL COURSE IN METALWORK, BIRMINGHAM

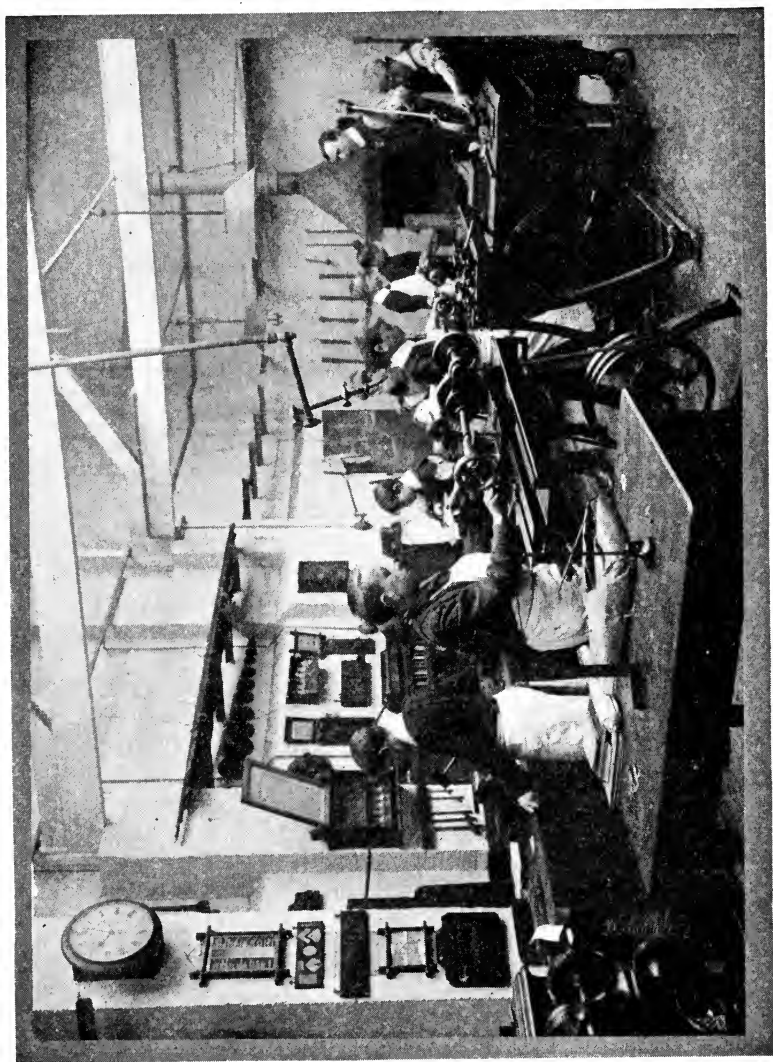
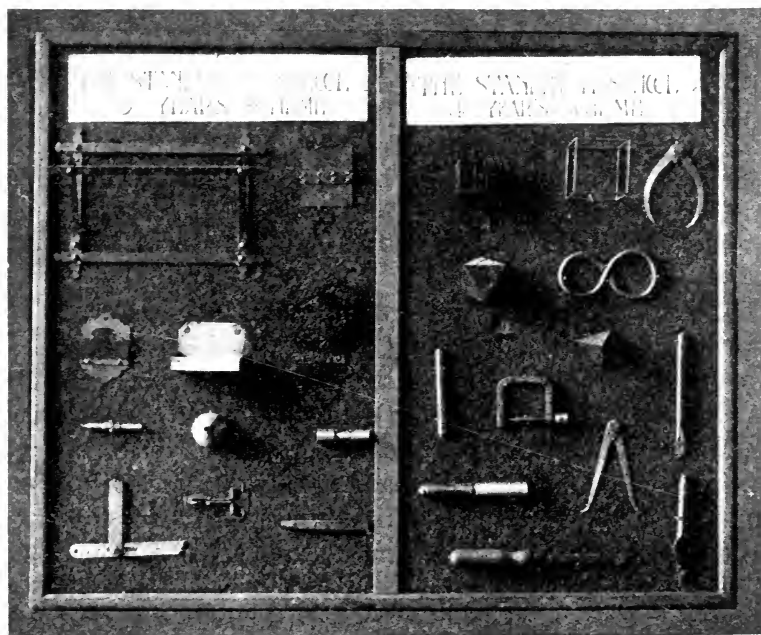
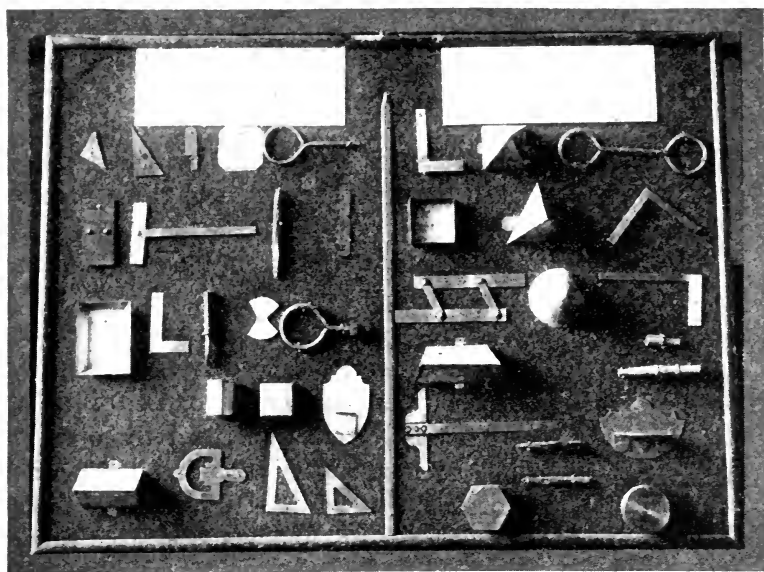

FIG. 90. METALWORKING SHOP AT STANLEY HIGHER ELEMENTARY SCHOOL,
Y. C.



FIGS. 91 AND 92. FOUR-YEAR COURSE IN METALWORK, HIGHER ELEMENTARY SCHOOL, LONDON, 1909

set square, 10 in. flat file, hammer. There was also a simple outfit for drawing. In addition to these tools there were others for general use which were kept in a case. (19—XI, 121)

The course of instruction is suggested by the series of models shown in Fig. 89. About two fifths of these involved forging or turning or both.

A less elaborate but effective equipment was at the Stanley Higher Elementary School in London, Fig. 90. The course of instruction in this school is shown in Figs. 91 and 92. The boys in this school were selected from surrounding schools at about twelve years of age because of special abilities or for other reasons. They remained three or four years. Their subjects of instruction included both wood-working and metalworking in addition to drawing, design, science, mathematics, geography, history, and the English language.

A noticeable feature of English manual training is the large number of home-made teaching devices: a chart to illustrate the wedge principle in the action of tools, greatly enlarged models of rip and crosscut saw teeth, a model to illustrate a winding surface, a model to show the right and the wrong ways to fasten two boards together with screws; exhibits of common timber woods, showing bark, leafage, growth, color, possibilities of finish, by-products, and characteristic uses.

55. Associations of Teachers and Their Publications. The manual-training teachers of Great Britain have organized into two major groups, one starting with advocates of Swedish sloyd principles and the other emanating from the activities of the City and Guilds of London Institute. At first, the former consisted mainly of teachers of other school subjects who had acquired certificates in manual work, and the latter chiefly of skilled craftsmen who had obtained certificates as teachers.

Attention has already been called to the fact that, beginning as early as 1884 (cf. 52), many British teachers went to Sweden to study sloyd in the summer courses at Nääs. In

June, 1888, some of these teachers and other persons interested in educational handwork formed an association known as the "Sloyd Association of Great Britain and Ireland." In September of the same year, the English students at Nääs formed a more exclusive association, the membership of which was confined to teachers who had been trained at the Nääs institution. This group adopted the title "Union of Sloyd Teachers of England." These two associations merged in 1891 and a few years later became the British Sloyd Association. This association set before itself the important work of educating public opinion in the principles upon which its members believed any system of school handwork should be built. Foremost among these principles were (a) "that no manual work should have a place in the school which had not for its first object the better and complete education of the child; (b) that such work should be used as a means of developing the intelligence through new channels; and (c) that the main object is not the gaining of dexterity in the use of tools or in the production of a workman."⁸

The National Association of Manual Training Teachers, came into being on November 7, 1891. It was organized by the men who had been most closely connected with the early experimental work done under the Joint Committee in London. Sir Philip Magnus was the first president and held that office for more than ten years. (20—62) The objects of the association, as stated in 1903, were (a) "the dissemination of educational views on the question of manual training; (b) to watch the working of the various Acts of Parliament, the respective minutes and circulars of the Board of Education, and other educational authorities, relative to manual training; (c) to organize meetings for the reading of papers, lectures, etc., and the consideration of any matter or question pertaining to manual training and its allied subjects; (d) to take united action in any matter affecting the interests of the profession." (10—II, No. 24, 4)

This association was organized with branches in the lead-

⁸In a letter received from John Cooke, for many years secretary of the British Sloyd Association, dated January 25, 1932.

ing centers of activity, as Birmingham, Bristol, Leeds, Liverpool, Manchester, Sheffield, and London. Each branch held its own meeting and joined with all the others in an "Easter Conference." Besides the members of these branches, there were "unattached members" in both near and remote parts of the Empire—even in Africa, Australia, and Canada.

In October, 1892, O. Newman & Co. of London began the publication of a magazine, *Hand and Eye*, to represent the interests of manual-training and kindergarten work. In the introductory statement concerning this magazine which appeared in the first issue was the following printed in italics: "The promoters of the various systems of manual work are invited to make use of the magazine for explaining and advocating their systems." Unfortunately, however, this same issue revealed a strong leaning toward sloyd and a feeling of opposition toward the work then developing in the Board Schools of London. (13—I, 1) This was regarded as a mistake, even by leaders in the sloyd movement. *Hand and Eye* was, therefore, looked upon as a sloyd magazine. In January, 1893, it was officially accepted as "the medium of communication between members" by the Sloyd Association of Great Britain and Ireland. (13—I, No. 5, 7) In August, 1901, the National Association of Manual Training Teachers started their own official organ, *The Manual Training Teacher*, under the editorship of Evan Ortner, one of Mr. Barter's assistants in London. The first issue made clear its purpose and policy. Without referring to the other magazine, it was obviously intended to represent a type of manual training and a viewpoint that had been neglected by *Hand and Eye*. This first number contained a strong article by Sir Philip Magnus and another by J. H. Reynolds, director of the Municipal Technical School at Manchester. The effect of the new magazine upon the earlier one was almost immediate. The last issue of *Hand and Eye* appeared in December, 1902. This left the sloyd interests without a magazine. Meanwhile, however, sloyd principles were being more generally accepted by educators, and association activity was increasing. Members of the British Sloyd

Association living in the North of England had formed a separate body to promote local needs though still, in most cases, retaining membership in the older association. "This new body was called the Northern Counties Sloyd Association and later the Educational Handwork Union. These two bodies worked together with the greatest friendliness and made many united efforts to secure the support of the Education Department and of the various schoolboards. . . . They no longer confined their attention to woodwork or to the particular expressions of the educational principles adopted at Nääs.⁹ A little later, February, 1908, this new association started its own official organ, *Educational Handwork*. Ever since that time, there have been two more or less competing official magazines to represent manual training and related work in Great Britain.

Beginning with the eighth volume in October, 1908, *The Manual Training Teacher* changed its name to *Manual Training*. This name was retained until September, 1923, when it became *Practical Education and School Crafts*, and the National Association of Manual Training Teachers became The Institute of Handicraft Teachers.

56. **The Training and Certificating of Teachers.** In 1884, at the public opening of the new building of the City and Guilds of London Institute at South Kensington, the Prince of Wales referred to that institution as especially a training college for teachers of technical subjects. (9—IV, 915) As this Institute was provided with instruction shops and as Philip Magnus, its director, was one of the leading promoters of the manual-training idea, it is easy to understand why the City and Guilds of London Institute became the center of instruction for manual-training teachers. As early as the spring of 1887, the Institute opened classes in tool instruction to masters in the elementary schools. The classes were largely attended and the enthusiasm for the work was so great that many of these men continued through the summer and returned again when the fall session opened. (9—II, 1046)

After the regulations under the Code of 1890 became oper-

⁹In letter received from John Cooke, dated January 25, 1932.

ative and Government grants were available for manual training, there was a demand for more teachers. There were two sources of supply for such teachers: (a) Board school teachers of other subjects who had taken courses in manual training, and (b) the better educated artisans in the skilled trades who passed examinations for teachers. Many of the stronger teachers came from the latter source. The City and Guilds of London Institute prepared a detailed syllabus of a course of instruction in woodwork for elementary-school teachers, covering a period of two years, and began the practice of granting certificates on the results of a practical test and written examination. Taking these examinations were both teachers and artisans. The publication of the syllabus led to the formation of classes in other cities, and the number of students and candidates for examination increased rapidly. This plan of certificating teachers of manual training has continued through the years since that time. Under this plan, a teacher in any part of the British Empire may become a certificated teacher of manual training. And such certificates are generally accepted by school boards as proof of ability to teach this subject. During the first nine years—up to 1901—no less than 2,695 persons had received this manual-training teachers' certificate. (10—I, 3)

While the certification plan of the City and Guilds of London Institute was acceptable to many leaders in the manual-training movement, it did not satisfy all of them, especially those who would place greater emphasis on the general educational value of the handwork and less on its technical value. In January, 1897, upon the initiative of the Educational Handwork Union, a conference was called at Leicester. The members included representatives of "school boards, county councils, secondary schools, and other educational institutions." (13—V, 127) Out of the varied opinions expressed at the conference came the decision to organize the Board of Examiners for Educational Handwork which would be national in purpose and would endeavor to represent "all sections of educational workers." A provisional board of fifteen members was at once appointed.

(13—V, 181) John Cooke, secretary of the British Sloyd Association, was made secretary of this new certificating body, a position which he held until he was appointed an inspector of handicraft by the Board of Education in 1910. School boards could now take their choice of certificates in making appointments, and teachers could seek certificates from either or both certificating bodies. The National Association of Manual Training Teachers and the Educational Handwork Association each sponsored a summer school for the training of teachers.

But the actual work of training teachers for the larger cities was done by local school boards (after the Education Act of 1902, by the County Councils) or by technical schools, or by both in cooperation. In London, the teachers of woodworking and metalworking came to be supplied from two sources, (a) from the pupil teachers' classes at the Shoreditch Technical School, which, in 1909, was turning out about ten teachers a year, and (b) from Saturday classes of teachers and mechanics.

The four-year course for teachers at the Shoreditch Technical School was as follows:

<i>Year</i>	<i>Hours per week</i>			
	I	II	III	IV
English	5	5	4	4
Mathematics	4	4	4	4
Art	6	6	2½	2½
Woodwork	10	10	6	6
Metalwork	0	0	3	3
Teaching	0	0	9	9
Geometry	1½	1½	0	0
Cardboard Work	2	2	0	0
Machine Drawing	0	0	½	½

The "art" in this program of studies included drawing, modeling, plaster casting from clay models, and wood carving. It included also building construction, trusses, furniture drawing, and designing inlays, carvings, and metalwork—hinges, escutcheons, pulls, and the like. During the first year, three hours a week were given to clay modeling and

wood carving. The modeling was a connecting link between the designing and the shopwork in both wood and metal. Two other facts in connection with the art training of the teachers were: (a) That many photographs of fine inlays, carvings, and metal fixtures in the South Kensington Museum were almost constantly in use in the design classes; and (b) that the students were trained to do a high type of notebook work. Their notebooks were characterized by neatness, thoughtful organization, careful writing, clear lettering, and good drawings for illustrations.

The emphasis thus given to designing and to its practical application in the course for the training of teachers bore fruit in the "handicraft" which followed the period now under consideration.¹⁰

But completing the outlined course in either of these did not give a man a certificate to teach. That must be obtained from the Examining Board of the City and Guilds of London Institute or from that of the Educational Handwork Association. In 1909, the City and Guilds of London Institute examination included first-year examinations in (a) wood-working and (b) drawing and one year later the final examinations in (c) woodworking, (d) drawing, (e) the technology of the subject, the equipment of the manual-training shop, methods of teaching manual training and class management.

The practice teaching was done in classes of boys that came to the school and in the manual-training centers of the city. (19—XI, 15 to 21)

At this same time, 1909, Manchester was training teachers on a five-year apprenticeship plan. To qualify as an apprentice, or pupil-teacher, a candidate was required to pass an examination in algebra, geometry, history, geography, science, French, woodwork, drawing, and cardboard work. He must (a) be not less than sixteen years of age and not more than eighteen, must (b) produce satisfactory testimonials as to character and general aptitude for imparting

¹⁰For a statement concerning the handicraft in the elementary schools of London in 1926, see Whitecomb, F. C., "Industrial Education in Europe—I, London." *Industrial Education Magazine*, Vol. XXVIII, pp. 148—152.

knowledge, and special aptitude for handicraft and drawing, and must (c) satisfy the medical officer as to physical fitness for the work of teaching. During the period of apprenticeship, each pupil-teacher must spend two half days a week at the Pupil-Teachers' College, one-half day at the Municipal School of Art, where he was a member of a special class for elementary school teachers, and one or two half days at the Municipal School of Technology, where he pursued the engineering apprenticeship course. Such apprentices were paid on a sliding scale ranging from \$135 a year to \$325. For the first two years an apprentice was called a pupil teacher and for the next three a junior assistant. During the first three years he must obtain his teacher's certificate from the City and Guilds of London Institute. (19—XI, 351 to 354)

57. **Elementary Handwork.** Early in 1888, a committee of the London School Board, after collecting much evidence on reforms needed in the elementary schools, endorsed the opinions of experts that "the mental or brain work, which occupies the great bulk of the time in all schools, is composed for too much of appeals to the memory, resulting at the best in the retention in the child's mind of a mass of undigested facts, and far too little of the cultivation of intelligence and the awakening of the reasoning faculties." (13—V, 50) This committee had been especially assisted in reaching its conclusion by Inspector George Ricks, who presented a syllabus of exercises in handwork "intended to bridge the gap between the infants' school and the technical or trade school." A. Hawcrige, in one of his valuable articles in *Hand and Eye*, says "This syllabus undoubtedly marked an epoch in the development of the claims of manual instruction to inclusion in the work of all the classes of the elementary school." It showed clearly that the manual training of the elementary schools "must be *general*, not *special*, and that its claims to recognition must be based on its educational rather than its industrial utility." This syllabus was the basis of Mr. Ricks' later book on *Hand and Eye Training*. (13—V, 51)

As a result of the committee's report, in July, 1888, the School Board of London adopted the following resolution:

That the methods of kindergarten teaching in infants' schools be developed for senior scholars throughout the standards and schools so as to supply a graduated course of manual training in connection with science and object lessons, but not so as to include teaching the practice of any trade or industry; and that the method of kindergarten in the senior schools be tried at first in a few special schools throughout London. (7—57)

Although many years elapsed before anything approximating such a comprehensive system was actually in operation in the schools of London, this resolution expressed an ideal and pointed the way for future effort.

In 1895, the Government Department of Education sought to make elementary handwork compulsory by including in the Code the teaching of occupations suitable for the three lower standards, but the compulsion was withdrawn almost immediately because the teachers in the schools were untrained in handwork and were "largely ignorant of the purposes of the proposed new subject." "The official circular of March, 1896, which followed the withdrawal of the compulsion, endeavored to introduce various manual occupations by persuasion." This circular included many practical details. (21—2)

In 1910, the Government Board of Education issued a bulletin for official use on "Manual Instruction in Public Elementary Schools." This discussed the value and place of handwork in the schools, the training of teachers, the regulations contained in the Code, certain conclusions, and notes on various kinds of handwork such as (1) clay and plasticine modeling, (2) paper cutting, folding and modeling, (3) cardboard modeling, (4) light woodwork, (5) cane weaving and basket making, (6) raffia and wool weaving, (7) wire work, (8) string work, and (9) miscellaneous forms of work such as fretwork, wood carving, leather work, and Venetian iron work. The conclusions presented were:

1. We consider that handwork should be regarded as an essential feature in the curriculum of every elementary school, and that all possible means should be adopted to encourage it, although we see difficulties in the way of its being made compulsory at present.

2. We consider that there should be a continuous and progressive course of handwork throughout the schools from the infants' stage upwards, and that it should be regarded as a method rather than a separate subject of instruction.

3. Although we recognise that the majority of existing teachers have had no special training in handwork, we do not regard this as an argument for postponing the introduction of this form of work. We think, however, that it is eminently desirable that a knowledge of handwork principles should be an element in the training of all future teachers, and that increased facilities should be available for giving such instruction to existing teachers.

4. We consider that the ideal system is one in which all forms of handwork should be taught in the schools themselves by the ordinary teachers, and that, in schools of sufficient size, a room should be set aside for this and kindred purposes. At the same time we fully appreciate the valuable work that is being done in the handicraft centers, though we are of opinion that more might be done to bring them into touch with the ordinary work of the schools. (21—27)

In discussing the "chief points in a scheme of handwork," this bulletin suggested the desirability of keeping in mind two main tendencies in child nature, the artistic and the mechanical, "the former leading, in the highest form, through the cultivation of the sense of beauty and the power of expression, to the work of the true artist; and the latter, based on the more objective and mechanical study of nature, to the work of the engineer and the inventor. The architect's work well exemplifies the union of the two." (21—9)

With strong and conflicting viewpoints, emphasized by partisan associations of teachers, examination boards, and training schools for teachers, it was inevitable that, under the official freedom allowed, the teachers should work out a great diversity of schemes of handwork, employing a variety of materials. Very substantial proof of this statement is found in *The Book of School Handwork*,¹¹ edited by H. Holman, formerly professor of education in the University of Wales, and a leading exponent of handwork in education. This consists of six large volumes and includes more than 1,400 pages. It is essentially a cyclopaedia of practical information on handwork subjects and methods by the leading teachers of handwork in the British Isles. The volumes are profusely illustrated with drawings, photographs, and some

¹¹Published by Caxton Publishing Co., London.

color plates. Some of the subjects treated are sandwork, toy-making, brushwork, weaving, wool spinning, constructional geography, handwork at the beginnings of arithmetic, knife woodwork, easy woodwork for young children, handwork

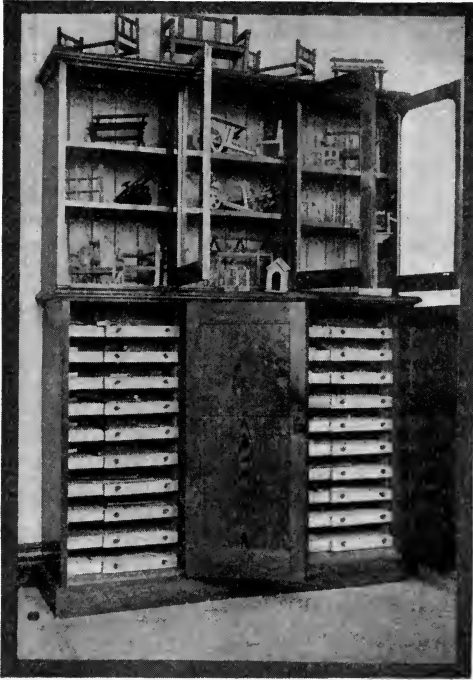

FIG. 93. "WORK BOARD" EQUIPMENT FOR WOODWORKING

and the teaching of writing and reading, chalk carving, English basketry, handwork and gardening, paper modeling for infants, clay modeling, chip carving, light metalwork, paper and cardboard modeling, handwork and history, color work for infants, string work, handwork and science, book-binding for schools, leatherwork, coiled and stitched basketry, paper and cardboard work for seniors, and light woodwork for country schools. All these types of work are in addition to the many articles on tools, materials, models, methods, and the like for shopwork in both wood and metal for the upper standards.

One of the early, most distinctive, and thoroughly wrought-out courses in light woodwork was that developed at Manchester by the superintendent of handicraft, Joseph H. Judd. Pupils worked on an ingeniously devised "work board," which, with the tools required, were kept in a case, Fig. 93, above which was provided display space for completed models. Mr. Judd's course was published in book form in 1906 under the title *Learn by Doing*.

In sharp contrast with the light woodwork of Mr. Judd adapted to city-school conditions, was the handwork developed by John Arrowsmith, headmaster of a school in Halifax. In open-country conditions with playgrounds, large garden, open fields, and space for henhouse, dovecot, aviary, and the like, he endeavored to cultivate "the new-old spirit of communal life." A great variety of building and working materials was provided and the handwork in numerous forms became an essential part of a unified educational scheme. (22—II, 219-230)

Between these two schemes or paralleling them, some placing emphasis on correlation with science, others with arithmetic, or literature, and many with art, through modeling, drawing, chip carving, needlework, metalwork, brush drawing, basketry, leatherwork, weaving, and other art crafts for which British craftsmen are famous, elementary handwork came to occupy a vital place in the work of the elementary schools.

SOURCE MATERIAL VII, A

MANUAL TRAINING UNDER JOINT COMMITTEE OF SCHOOL BOARD OF LONDON
AND CITY AND GUILDS OF LONDON INSTITUTE

From Report of the *School Board for London* for the year 1888

In May, 1887, a letter was received from the City Guilds asking the Board to appoint a deputation to consult with a number of their members for the purpose of considering a scheme for the equipment and maintenance, for one year, of four schools of elementary technical education, at a cost of about £1,000.

A Special Committee was accordingly appointed by the Board, which Committee met the representatives of the Guilds Institute. After a consultation, the appointment of a Joint Committee was agreed upon, consisting of eighteen members, of whom nine were appointed by the School Board, and nine by the Institute. . . .

The Joint Committee resolved to establish six centers, at which classes should be conducted—three on the north side, and three on the south side of the Thames—subject to their obtaining from the School Management Committee of the School Board permission to use, for a period of not less than one year, such classrooms or premises as might be asked for by the Joint Committee, and might be suitable for their work.

The School Board could not legally render pecuniary aid out of the public rates, but they agreed to grant the necessary premises, free of charge; the expense of maintaining the classes being undertaken out of the sum of £1,000 given by the City Guilds Institute. The Joint Committee ultimately selected six centers, at each of which a class was to be held. The headmasters of the surrounding public elementary schools, both Board and non-Board, were invited to hold a conference with the Committee as to the best methods of securing the attendance of boys from such schools, and also as to the number of the scholars in proportion to the several school rolls. The headmasters very cordially entered into the project, and have since manifested considerable interest in the progress of the work.

As to the details of the method of instruction, the Committee deemed it advisable, for a time, to abstain from giving specific direction to the instructors who should be appointed, and to leave the instructors to frame their own methods, subject to the broad lines laid down under the following

SYLLABUS

I	II
WOODS COMMONLY USED—	TOOLS—
(a) Conditions of Growth	1. <i>Boy's Set</i>
(b) Felling and Seasoning of Timber	(a) Description
(c) Properties of Woods	(b) Manipulation
(d) Heartwood, Sapwood, etc.	(c) Sharpening
(e) Geographical Distribution	2. " <i>Center</i> " <i>Set</i>
Museum of prepared specimens of woods to be formed in each center.	(a, b, c) As above less of detail

3. *Nails and Screws*

(a) Kinds

(b) Uses

4. *2 ft. Rule*

To be specially treated

III

PRACTICAL WORK (A)—

Measuring and Sawing to Line

Squaring Piece of Wood

Nailing and Screwing

(d) Preparation of Working Drawings

IV

PRACTICAL WORK (B)—

(a) Construction of Simple Joints according to Model and Drawing

(b) Construction of Simple Objects founded on Simple Joints

V

Simple Joints

(a) Exhibition of Model of Joint

(b) Explanation of Drawing of Joint

(c) Connection between Model and Drawing

PRACTICAL WORK (C)—

(a) Gluing

(b) Hingeing

(c) Knots—Tying, etc.

With a view to securing the best possible results, as well as to testing the characteristics of two classes of teaching, the Committee determined upon engaging at least one assistant schoolmaster, who should hold a certificate of having been trained in manual work. The School Management Committee of the school board consented to allow the permanent position of such teachers, as might be selected by the Joint Committee, to be kept open for them. Applications, by circular, were therefore invited from assistant teachers under the Board who had experience in the class of work above described. There were thirty-three applications made by such teachers.

The Committee also decided that two practical artisans should be engaged to assist the instructors; and advertisements were published in the leading trade newspapers for candidates to fill the post of assistant instructor, in answer to which thirty-two applications were made. The Committee being of the opinion that there might possibly be among those who applied for the post of assistant instructor some candidates with the necessary qualifications for the post of instructor, examined these candidates with a view to their suitability for the higher post. One of such candidates appeared to possess such qualifications, and he was transferred to the other list.

Ultimately, John C. Pearson, assistant master at the William-street, Hammersmith, Board School, and S. Barter, who had already had twelve years' experience in science and art teaching, and who held various high-class certificates, were appointed instructors, each at a salary of £105 a year. C. W. Boxall, and A. Whillier, carpenters and joiners, were appointed assistant instructors, each at a salary of £80 a year.

Two plans of withdrawing the boys from their respective schools to attend the manual-training classes were suggested. One of these was that of holding the manual-training classes at such hours of the day as would enable the pupils to give up about one hour of the regular school time, twice a week, and to extend their manual training into a period beyond the usual school hours. The other was that of attending the manual-training classes, once a week, during the whole of a morning or afternoon, and thus give up one school

attendance per week, in order to devote a complete half-day to the work of manual training. This latter plan offered the advantage of withdrawing each boy from his ordinary lessons once, instead of twice, in each week; and, also, that of making his lesson in manual training more continuous. On the recommendation of the headmasters, who conferred with the Committee, this course was adopted and has been fully justified by the result.

Under this plan, a class is conducted at a particular center from 9 to 12 in the morning, and is attended by about thirty boys, who are drawn from surrounding schools within a radius of about a mile. In the afternoon of the same day, a second class is conducted, and it is attended by another set of scholars; thus, about sixty boys receive instruction at the one center during the day on the north of the river, and about sixty others at another center south of the Thames; which equals about 120 each day. . . .

The actual attendance varies month by month, but may be taken as ranging from about ninety to ninety-six per cent of the possible attendances.

The workshops, in each case, consist of a single room. The one at St. Andrew's street was planned at the time of the school being built, with a view to its being ultimately used as a technical room. At Broad-street, Ratcliff, and Sumner-road, Peckham, outbuildings in the playgrounds have been utilized and fitted up. At Vittoria-place School, a disused building, belonging to the Board, was occupied. At Summerford street, part of the premises provided for the ordinary school accommodation has been used for a manual-training class, subject to being given up whenever the Education Department should deem it necessary. A classroom at the "Alma" School was similarly occupied; after it had been used for several months, the Board, upon the requirement of the Education Department, withdrew the permission given by them to the Joint Committee. The School Board granted the use of an iron building, not at present required for other purposes; this building is now erected, adjoining the School.

For the equipment of each of the six centers, the Committee had carpenter's benches erected, fitted with vises and other necessary attachments. The sizes of the benches vary in proportion to the number of scholars which the room will accommodate, but are about 14 feet long and 2 feet wide.

As the aim of the Committee is to employ 30 boys, as nearly as possible, at one time, the approximate arrangement is to have five benches with six vises to each. Each boy has a set of tools which cost 15s., or about £22 10s. for these tools at each center.

In addition, there are the general tools which have to be used in common, the cost of which is about £10 16s. for each Center. The benches (five, more or less) cost from £4 16s. to £6 3s. 6d. each, according to size. There are also tool baskets, tool cupboards, sawing stools, and some trifling additions, the cost of which is comparatively nominal. To assist in giving the pupils an intelligent idea of the instruction which they receive, the Committee have instructed Mr. Barter to collect suitable specimens of wood, to form two museums; one for the centers on the north, and one for those on the south, of the Thames. These specimens have been suitably labeled, and have cost £4 in all.

The regularly recurring expenses include monthly salaries, which will amount to £370 during the year, for the instructors and their assistants; also

timber, which is estimated to cost not exceeding £2 per month for each center.

A current expenditure, the average of which cannot be exactly struck at present, is that of timber which is cut up in the process of being made into joints; there are, also, sundry minor expenses which are not of regular occurrence.

The instructors furnish the Committee with a report at the end of each month, and also with a table of attendances. The reports, so far, have given satisfaction, and evince a strong earnestness on the part of the instructors and their assistants, as well as deep interest and steady progress on the part of the boys. Several gentlemen have paid visits to some of the centers, and have expressed approval of the instruction. Among these visitors may be noted Sir Bernhard Samuelson, M.P.; Sir Henry Roscoe, M.P.; G. W. Atherton, of the State College, Pennsylvania; Edward Coombes, president of the Board of Technical Education, New South Wales; The Rev. Dr. Dale (of Birmingham); The Hon. Lyulph Stanley; together with headmasters of neighboring middle-class and public elementary schools. In addition, it is pleasing to note that parents express great satisfaction with the influence exercised by this instruction in manual training upon their boys, and the zeal manifested by them in connection with it. There appears to be a healthful spirit of emulation among the pupils, the benefit of which will, it is hoped, be exceedingly gratifying when the Committee make a more complete assessment of the results achieved.

SOURCE REFERENCES

1. Magnus, Sir Philip. *Educational Aims and Efforts: 1880-1910*. Longmans, Green, and Co., London, 1910.
2. Watson, Foster. *The Encyclopaedia and Dictionary of Education*. Sir Isaac Pitman & Sons Ltd., London, 1922.
3. *The Contemporary Review*, London.
4. Balfour, Graham. *The Educational Systems of Great Britain and Ireland*. The Clarendon Press, Oxford, 1903.
5. *Extracts from the Reports of Her Majesty's Inspectors of Schools*. Longman, Brown, Green and Longmans, London, 1852.
6. *Report of School Board of London*, 1888.
7. *Report of School Board of London*, 1889.
8. *Second Report of the Royal Commissioners on Technical Instruction*, London, 1884.
9. Clarke, Isaac Edwards. *Art and Industry*. U. S. Bureau of Education, Washington, 1898.
10. *Manual Training Teacher*. Journal of the National Association of Manual Training Teachers, England.
11. *Eighth Annual Report of the Commissioner of Labor*, Washington, 1892.
12. Montague, F. C. *Technical Education*. Cassell & Company, London, 1887.
13. *Hand and Eye*. O. Newman & Co., London.
14. *Manual Training*. (Successor to *Manual Training Teacher*) Journal of the National Association of Manual Training Teachers, England.
15. *Fortnightly Review*. Chapman and Hall, London.

16. *Report of the Consultative Committee on Practical Work in Secondary Schools*. Presented to Parliament, Board of Education, London, 1913.
17. Barter, S. *Woodwork* (The English Sloyd). Preface by George Ricks. Fourth Edition. Whittaker & Co., 1905.
18. *Report of the Commission Appointed to Investigate the Existing Systems of Manual Training and Industrial Education*. Boston, Massachusetts, 1893.
19. *Manual Training Magazine*. The Manual Arts Press, Peoria, Illinois.
20. *Handbook, Conference on Practical Education*, Cheltenham, 1923.
21. *Manual Instruction in Public Elementary Schools*. Board of Education, London, 1910.
22. *The Book of School Handwork*. Edited by H. Holman. Caxton Publishing Company, London, 1913.

CHAPTER VIII

TECHNICAL EDUCATION IN ENGLAND

58. **Use of the Term "Technical Education."** In England, the term "technical education" has suffered because of its popularity. Sometimes it has been used to designate the teaching of a trade. At other times, it has been definitely stated that it did not include trade teaching, but referred to the more general teaching of science, drawing, and manual training in the elementary schools. At still others, it has referred to more advanced instruction, sometimes highly specialized, in schools of secondary or higher grade. In 1877, Professor Thomas Henry Huxley (1825-1895), the celebrated biologist, said, "Technical education, in the sense in which the term is ordinarily used, and in which I am now employing it, means that sort of education which is specifically adapted to the needs of men whose business in life is to pursue some kind of handicraft." (1—XXIII, 48) "The object of technical education," said Sir Lyon Playfair (1819-1898) in 1888, "is to give an intelligent knowledge of the sciences and arts which lie at the base of all the industries. It is best given early in life before the youth goes into the workshop for his practical training." (2—XXIV, 327)

On the other hand, the report of the Royal Commissioners on Technical Instruction, published in 1884, seems to expand the meaning to include the education of "workpeople, foremen, and proprietors and managers of industrial works." (3—I, 16) It is evident, therefore, that in England, during the period under consideration in this chapter, the term "technical education" was applied (a) to a group of general-education subjects in the elementary and higher schools, (b) to very specific trade teaching, (c) to higher instruction in science and engineering, and even sometimes (d) to commercial studies.

A very important contributing factor to this confusion of terms was the action of the Government in appropriating large sums of money to aid technical education while general secondary education received no such official recognition. The need for secondary education was so urgent "that the administration of the Statute was twisted in order to satisfy it." Technical education, says Balfour, was interpreted to include "all secondary education except the dead languages and non-commercial English." (4—XXI)

59. The Great Awakening. What has been called the industrial "scare" started with the World's Fair at the Crystal Palace in London in the year 1851. This great exposition was intended to demonstrate to all the world the superiority of British manufactured articles. In a measure, it did that and, in doing so, aroused the jealousy of other nations. But in those departments of manufacture requiring superior skill and refined design, it was evident that France had surpassed Britain. In 1855, the Continental countries met the British challenge by inviting Britain to compete in Paris. This revealed remarkable progress on the Continent. Again, in 1862, in London, Britain was confronted with a host of rivals. As stated by W. T. Thornton, "Switzerland was there with Schonbein's wonderful aniline colors; Prussia, with enormous ingots of Krupp's steel; America, with some of her exquisite machines for economizing labor; Italy, with her reproductions in glass and gold of old Venetian and Etruscan fancies; France, with stately steam engines in number this time sufficient to show that what had lately been taken for her overstrained efforts had now become part of her regular routine work." (5—XXIV, 323)

At the Paris exposition of 1867 came still another warning. English experts, manufacturers, artisans, and jurists, all admitted that England was beaten in the competition, nor were they less unanimous concerning the cause. It was to be found in the superior education of Continental workers.

In the year 1871, there was published in London a pamphlet written by Dr. John Mill which summarized the results of these world fairs as follows:

The Great Exposition of 1851, and those which have been subsequently held, have given a rude shock to our insular pride and self-complacency by showing us that our former excellence in numerous branches of manufacturing industry has been lost; and, as a natural consequence, that we are beaten in many of the open markets of the world, not in one only, but in many of the great staple articles of commerce. We have been content to remain in such perfect ignorance of what the great civilized nations of Europe were doing, and the thing grew so gradually and imperceptibly upon us, that we rubbed our eyes in wonder on awakening from a pleasant slumber to find ourselves beaten. But beaten we were, and that disgracefully too; and it only remained to ascertain the extent of our defeat and regain our lost position.

The first thing that struck the observer of the productions of the industries of nations was that we were rivalled in those articles which required artistic skill and intelligence in their production. In everything heavy and ponderous, we held our own and held it bravely. No nation has yet rivalled us in the use of the steam hammer, in the construction of a bridge or railways, in linking continents together with telegraphic cables or grappling and raising the broken fragments from the bottom of the deep ocean. When we approached the higher and more delicate branches of industry, however, we found ourselves beaten at almost every step. . . .

The whole matter resolved itself into one point—education. Other nations were beating us in artistic and industrial productions, simply because they had been taught how to do it. . . . Briefly stated, then, the matter amounts to this: More than half a century ago, in 1815, it occurred to some educationalist on the Continent to establish trade schools. (6—8 to 12) . . . any kind of education, however complete, will be very imperfect unless it prepares a man to perform some duty in life which shall procure him an honest and independent subsistence. (6—59)

60. The Science and Art Department. As early as 1830, the House of Commons appointed a committee to report on the best means of “extending a knowledge of the arts and the principles of design” to the industrial workers of England. The committee made a study of the art instruction given in several Continental countries and reached the conclusion that English designs were inferior to French and for that reason certain English manufactured products were not sold abroad. In 1836, the committee’s report and recommendations resulted in an appropriation to establish a normal school of design under the management of the Board of Trade. (4—155) This school was opened the next year, 1837, in Somerset House on The Strand. Three years later, in 1840, funds were provided to assist in the equipment and support of schools of design in several manufacturing centers, Manchester, Birmingham, and Coventry being among the first. By 1850,

there were about twenty such schools receiving State aid in Great Britain and Ireland.

Then came the great exposition of 1851, followed immediately, in 1852, by the establishment of a Department of Practical Art. In 1853, the school of design was moved to Marlborough House and was called the "National Training School of Art." Meanwhile the exposition of 1851 had stimulated a demand for more instruction in science, as well as in art. A Government school of mines and of science as applied to the arts was opened in 1851. The Board of Trade favored a central school of the highest grade which would be a training school for teachers of science as well as a school of applied science. Therefore, when, in 1853, the Royal College of Chemistry, which had been established in 1845 by private means, was offered to the Board, it was accepted and added to the Department of Practical Arts. (7—34—36) Lyon Playfair was made the executive head of this newly combined Government service and it was given the title of "Science and Art Department." So it came about that under the Board of Trade there had been provided a system of State aid and two Government-supported centers for training teachers—one for art and one for science, and for advance instruction for young men going into the industries.

As previously stated (cf. 59), the Department of Science and Art, in order to carry forward its work successfully, was obliged to reach over into the field of general secondary education. In what appears to have been an effort to unify and make more effective all education under Government control, the Department of Science and Art was taken from the Board of Trade in 1856 and placed in a new Department of Education under the President of the Privy Council. (4—13) Three years later, 1859, a comprehensive system of grants was adopted. Rules were made under which State aid might be obtained in teaching certain specified subjects. Grants were now allowed on the principle of "payment by results" and the necessary administrative organization devised to determine results. Under this system, instruction in mathematics, science, and technical subjects grew rapidly.

In 1861, in the science division, there were 38 classes with 1330 students; in 1886, there were 5862 classes and 94,838 students under instruction. (8—500) The art division grew even faster. In 1886, there were 86,033 students in training colleges, art schools, and art classes, besides 870,491 pupils receiving art instruction in elementary schools. (8—508)

In order to stimulate the cultivation of individual talent, a system of competitive scholarships was provided for pupils of the elementary schools. These scholarships included maintenance for one, two, or three years at some day school approved by the Department. In addition to these Science and Art scholarships, there were a few National scholarships for more advanced study, especially at the Government schools. With the growth of the Department, these schools raised their standards of instruction and their admission requirements. In 1890, the science school became the "Royal College of Science" and, in 1896, the name of the art school was changed to "Royal College of Art."

61. **The City and Guilds of London Institute.** The Government Education Department, of which the Science and Art Department had become a part, considered that the use of State funds for technical education should be "restricted to the encouragement of the teaching of pure science, as equally applicable to all industries." (9—107) This left instruction in the direct applications of science and art to specific trades and industries unprovided for. Fortunately for English technical education, there were in London several very wealthy Livery Companies¹ dating back to the guilds of the Middle Ages. Each of these companies was originally expected to look after the education of its own workers, and probably the tradition growing out of this custom, as well as the tradition handed down by the scholars of the Universities, would account for the attitude of the Education Department.

In the 1870's, when the need for applied technical instruction was coming to be more evident, "there was considerable

¹Livery Companies—guilds or companies having distinctive dress or badges.

unrest among some of the Livery Companies, who felt very strongly that, having regard to the terms of their charters, it was their duty to apply some part, at least, of their large funds in furtherance of a cause that might prove of the greatest possible benefit to the State." (9—85) So it came about, in 1876, at a meeting of representatives of the Livery Companies, that a resolution was passed, stating that it was desirable that these companies promote education, especially technical education, not only in London but throughout the country. (7—54) Two years later, the City and Guilds of London Institute was founded² and, in 1880, it was incorporated. Philip Magnus (later Sir Philip Magnus) was selected to direct its activities.

The purpose of the Institute from its beginning was to supplement the work supported by Government funds and to duplicate it as little as possible. Especially it proposed to provide the much-needed courses in the applications of science and art to the industries. It would occupy a position between the Science and Art Department on the one hand and the industries on the other. Its provisional program included "the building and equipment of a central institution, mainly for the training of teachers, the creation of one or more subsidiary schools in London, and proposals for assisting in the provision of technical schools in the principal manufacturing centers throughout the country, and for supplementing the Government classes in science and art by evening classes in technology." (9—86, 97) Many years after, Sir Philip Magnus, in writing about the beginnings of the Institute, said, "The prevailing opinion at the time was, that technical education mainly concerned the artisans, and very few persons then realized the urgent importance of providing a suitable training for the so-called

²In the year 1908-9, the following companies were contributors to the support of the Institute: Mercers', Grocers', Fishmongers', Goldsmiths', Skinners', Merchant Taylors', Salters', Ironmongers', Vintners', Clothworkers', Dyers', Leathersellers', Pewterers', Cutlers', Armourers', and Brasiers', Saddlers', Carpenters', Cordwainers', Plasterers', and Coopers'—*Report of Department of Technology, City and Guilds of London Institute, 1908-9.*

captains of industry, for those who would direct great engineering and manufacturing works, or for those who might assist, by the prosecution of research, in the discovery of new processes and in the application of the more recondite branches of science to industry." (9—86)

One of the first pieces of work undertaken by the new institute was the taking over and development of the technological examinations started by the Royal Society of Arts. In 1872, as one means of helping to raise the standard of technical instruction, this Society had inaugurated a system of examinations to supplement the examinations of the Science and Art Department. The first of these examinations was held in 1873. The subjects were (1) cotton manufacture, (2) paper manufacture, (3) silk manufacture, (4) steel manufacture, and (5) carriage building. One of the distinctive features of these examinations was that the examiners were men who were "capable of testing the practical knowledge and skill required in the application of the scientific principles involved in each art or manufacture." (7—58) The number of persons who took the examinations during the first five years was small, but increased in 1878 because the Clothworkers' Company had given the Society a fund of £250 to be used in paying grants to the teachers of the successful candidates in the examinations.

These examinations by the City and Guilds of London Institute gradually developed so that they became a very important factor in the progress of technical education. In 1910, for instance, examinations were given in 75 subjects. They were taken by 24,508 candidates in 418 places, and 14,105 passed. (7—61) The growth of this department is shown in the accompanying graph, Fig. 94.

The center of the activities of the institute was at the City Guilds Technical College at South Kensington. The cornerstone for the college building was laid by the Prince of Wales (later King Edward VII) in July, 1881. It was completed and formally opened in July 1884. The building was five stories in height. Fig. 95. In the basement there were physical laboratories and three large workshops with sky-

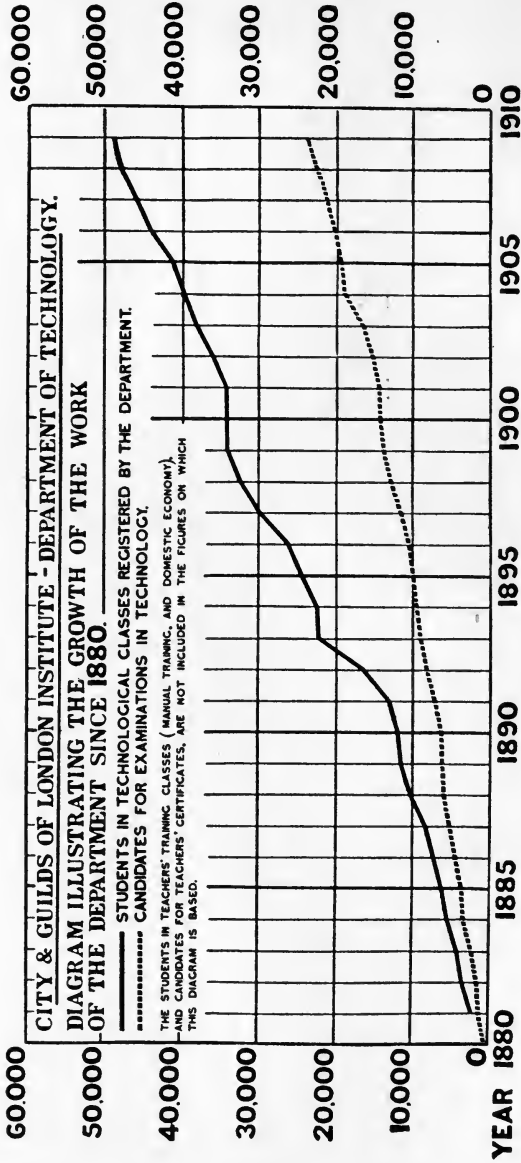

FIG. 94. GRAPH SHOWING GROWTH OF THE TECHNOLOGY DEPARTMENT OF THE CITY AND GUILDS OF LONDON INSTITUTE

lights. The building was provided with lecture rooms and classrooms as well as laboratories. (3—I, 404)

During the three years that this building was under construction, Director Magnus studied the great technical colleges on the Continent, especially in France, Germany, and Switzerland, and had decided that, in the course of time,



FIG. 95. CITY GUILDS TECHNICAL COLLEGE

the City Guilds Technical College should render a similar educational service to England. In 1925 C. T. Millis, said of the City and Guilds Technical College, "Since the date of the opening, reckoning the students for each year separately, over 12,000 have been in attendance." (7—67)

Another institution in London provided for by the City and Guilds of London Institute was the Finsbury Technical College, which was originally intended to serve as a model trade school, though it became much more than that. The building for this college was formally opened in 1883; but, beginning in 1879, both day and evening classes in applied chemistry and applied physics were conducted in another school building. To these was added, in 1881, the work of the Artisans' Institute, a pioneer in technical instruction for men in the trades, dating from 1874, as a trade-school department. These two groups formed the nucleus from which the College developed. (7—61) The professor of electrical engineering, Silvanus P. Thompson, was also principal of

the college. Both day and evening courses were given in (1) mechanical engineering, (2) electrical engineering, and (3) technical chemistry. (7—63) Before 1888, trade classes had been organized in (1) cabinetmaking, (2) carpentry and joinery, (3) metalwork, (4) plumbing, (5) bricklaying and brickcutting, (6) brickwork and masonry, and (7) builders' quantities. (7—64) The trade classes were under the supervision of C. T. Millis.

A third London center of practical education under the City and Guilds of London Institute was the South London Technical Art School. This was essentially a trade school for such art workers as (1) sculptors, (2) book designers, (3) pottery painting, and (4) house decoration. (7—66)

In accordance with the original plan, during the early years of the City and Guilds of London Institute, liberal contributions of funds were made to other schools and colleges giving instruction in trade and technical subjects. Many of these were outside of London—for example, The Manchester Technical School, The Leicester Technical School, the Sheffield Technical School, and the Engineering Department of the University College at Nottingham. Some of the Livery Companies gave additional funds: The Clothworkers' Company made annual grants and donations to schools that were assisting the textile industries. This company helped colleges at Bradford, Halifax, Huddersfield, Leeds, and schools in several smaller towns. The Skinners' Company assisted the Leather Department of Leeds University, The Drapers' Company provided scholarships for deserving students in the textile industries and a research scholarship in dyeing at Huddersfield Technical College. (7—68, 69)

Through the City and Guilds of London Institute and direct individual gifts, the Livery Companies of London gave the essential initial impulse to technical education in England.

62. The London Polytechnics. Two great sources of revenue for technical education have been mentioned: the Government grants, through the Science and Art Department, and the funds from the Livery Companies, through the City and Guilds of London Institute. There was a

third source: the London Parochial Charities. In 1878, a Royal Commission was appointed to consider what should be done with the large sums of money that were accumulating on account of bequests, the objects for which no longer existed. This Commission reported in 1880 and, in 1883, the City Parochial Charities Act was passed which allowed some of the Charities money to be used for the education of "the poorer inhabitants," through school instruction, lectures, libraries, and museums, and for promoting their physical, social, and moral welfare. (7—76) (10—211, 212, 213) This Act provided for special commissioners to work out the practical details, and, in doing so, the commissioners visited the Regent Street Polytechnic. Here they found the solution of their problem. (10—212) This institution was providing just the kinds of education that the poorer inhabitants of the city needed, including not only physical, social, and moral education, and instruction in the sciences and arts, but also training in those branches of technical and trade education that were so much in demand at that time. The commissioners therefore decided to assist in the establishment of more institutions of this type.

It has been said that the London Polytechnics "have no parallel anywhere else. They are English to the core." The first one grew out of a "ragged school" and produced a new type of institution which others followed. The story of the origin of the first Polytechnic may be told briefly as follows:

On leaving Eton in 1863, Quentin Hogg (1845—1903), Fig. 96, an athletic young man of eighteen, accepted a position with a firm of tea merchants. As he went about the city, he came across many poor and homeless boys and his heart cried out in pity for them. (10—49) But he was wise enough to know that, if he were to help them, he must first get acquainted with them and, to do that, he must be one of them. So he bought a second-hand suit of clothes, such as was worn by the shoeblacks, and a shoeblacking outfit. After office hours, he would "sally forth to earn a few pence by holding horses, blacking boots, or performing any odd jobs

that came his way." "He used to get home in time for breakfast, and, for some time, Sir James (his father) knew nothing of the two or three nights a week when his son supped on 'pigs trotters' or 'tripe and onions' off a barrow, and spent the night curled up in a barrel, under a tarpaulin or on



FIG. 96. QUENTIN HOGG

a ledge in the Adelphi Arches, learning to know the boys he meant to rescue, making their life his life, their language his language, in the hope of changing their thoughts and lives." (10—51)

After a few months of such experiences, he and a friend, in 1864, rented a room in "Of Alley," later known as York Place, Charing Cross, and, with the assistance of a woman teacher, started a "ragged school." This room, only twelve by thirty feet, was furnished with a rough table, a few chairs, and lighted with candles stuck in empty bottles.

(10—51) At first, the school was open only in the daytime, but soon older boys were allowed to come in the evening. This evening class grew so rapidly that very soon the room was so crowded that the class was divided into two sections of thirty each. In 1865, a second room was added and the next year the house next door was rented and used for lodging the homeless boys in order to keep them away from the degrading influences of the places where they were staying nights. (10—56)

By 1869, the school was in need of more space, and moved to a building on Castle Street. Here were sleeping accommodations for forty instead of thirty boys. While in this building, the school became less of a "ragged school" and more of an institution for education and for religious and social development. Nine years later, when it moved to Long Acre, it left the "ragged school" behind and became known as the Youth's Christian Institute. (10—92) The members, who now were from sixteen to twenty-two years of age, were of a higher type. Under the inspiring leadership of Mr. Hogg, the Institute became a self-governing group of young wage earners who looked upon it as their club and their center for recreation and education. (10—142)

A few years later, owing to the Institute's rapid growth, Mr. Hogg again began to look for a larger building. About that time the Polytechnic in Regent Street, a place of amusement, dating back to 1838, was offered for sale and was purchased by Mr. Hogg for the Institute. Fig. 97. So popular had this new type of institution already become that, within a very few months, the much larger building had become crowded. It was expected to accommodate 2,000 members and students but, before the end of the first winter, it had 6,800. An addition was made to the building, providing more classrooms, and space was excavated in the basement for a series of workshops. With its large lecture hall, its library, gymnasium, swimming pool, workshops, studios, laboratories; with its able teachers and low tuition fees, it was ready to render a great service to the youth and young people of London. Its industrial courses were wholeheartedly

approved by the London Trades Council because they were practical and because they were given *only to apprentices* who were already in the trades they were studying. In this way, the Polytechnic avoided all troubles with the unions. It received also the commendation of the London Technical



FIG. 97. REGENT STREET POLYTECHNIC, LONDON

Council and of two of the Royal Commissioners on Technical Instruction. (10—219)

As early as 1884, apprentice courses had been developed for bricklaying, metal plate work, electrical engineering, engineering, plumbing, watch and clock making, and carriage building. Each of these courses included besides practical shop instruction, related mathematics, science, and drawing. For example, the plumbing course included geometry, building construction, elementary chemistry, sanitary engineering, applied mechanics, and plumbing. Besides these, there were courses in photography, tailor's pattern cutting,

printing, metal turning, wood turning, cabinetmaking, carpentry, drawing, and modeling. (3—I, 412, 413)

When the Special Commission under the provisions of the Parochial Charities Act inspected the Polytechnic, Quentin Hogg had already spent about £100,000 in developing it. Because the Commissioners were convinced that the polytechnic type of institution met the conditions of the Act, they decided to make a capital grant of £149,500 for polytechnics in London and to award £11,750 of this amount to the Regent Street institution and promising to give it £3,500 each year. (10—215)

Thus began the support of the polytechnics under the Parochial Charities Act. With the Regent Street institution as a model, others came into being. The People's Palace (later the East London Technical College) opened in 1888, was the practical outcome of Sir Walter Besant's book *All Sorts and Conditions of Men*. (11—1554) In 1904, the London Polytechnics with their members and students were listed as follows:

	<i>Members</i>	<i>Students</i>
Goldsmiths' Institute, New Cross, S. E.	1344	5000
Birkbeck Institute, Chancery Lane, E. C.	1300	3046
Borough Polytechnic, Borough Road, S. E.	1777	2092
East London Technical College, People's Palace, E.		3000
South Western Polytechnic, Chelsea, S. W.		1758
City of London College, Moorfields, E. C.	846	2135
Battersea Polytechnic, Battersea Road, S. W.		3377
Northampton Institute, Clerkenwell, E. C.	993	1748
Sir John Cass Institute, Jewry Street, E. C.	83	485
Northern Polytechnic, Halloway Road, N.		2780
Woolwich Polytechnic, Woolwich, S. E.	250	1200
The Polytechnic, Regent Street, W.	4200	14,397
	10,793	41,018

Many of the members were also students, so that the total number of students has been estimated to be over 45,000. (10—228)

Gradually the educational work broadened. Girls and

young women were admitted and courses planned especially to meet their needs. The age limits from 18 to 25 were stricken out. While at first shopwork and technical subjects were given a place of preeminence, later, as income permitted, literary subjects were included. More recently, London University provided courses of lectures and classes in literary subjects for most of the polytechnics. Some of these institutions established junior continuation schools and opened their workshops to day students. Battersea Polytechnic and the Northern Polytechnic each provided a training course for teachers of domestic economy. While all the polytechnics operated on the same general plan, each offered whatever courses and encouraged whatever forms of recreation were most needed in its section of the great city. (11—1319)

In 1894, the London Polytechnic Council was created to regulate the appropriation of funds, organize the teaching, arrange for examinations, and take over the general supervision of the work of these institutions. Ten years later, in 1904, this Council was dissolved and its powers were turned over to the London County Council, thus forging the connecting link between the polytechnics and the system of public schools. (11—1319)

63. The Typical English Technical School. Reference has already been made (cf. 61) to the fact that the London Livery Companies, both independently and through the City and Guilds of London Institute, contributed funds very generously to the maintenance and further development of many institutions outside the metropolitan area, devoted to trade and technical education. These institutions were in the manufacturing districts, and they varied in character according to the kind of manufactured goods produced. By the local manufacturers as well as by the Livery Companies, these institutions were encouraged to specialize their instruction to meet local needs.

This idea of specialization, it will be recalled, was quite contrary to the efforts of the Science and Art Department of the Government, which encouraged only such technical education as applied to all industries. The powerful manufactur-

ing influences toward specialized technical training on the one hand, the strong subsidizing influence of the Government toward general industrial education on the other, and the further fact of a recognized lack of secondary general education, account for the character of the system of schools and colleges for technical education which developed in the smaller cities of England.

The point of view of many of the leading advocates of technical education in the Eighties was well set forth, in 1887, in two articles in the *Westminster Review*, from which the following is quoted:

It has at last become recognized that a school boy may be materially helped in his choice or pursuit of a calling by his training at school, and that it is the duty of the State no less than of the individual to see that each child shall be taught to be useful and effective in the world. It is also admitted that the discipline of the mind may be promoted by the theoretical study of the principles of industrial and commercial life, as well as by classical learning. (12—CXXVIII, 187)

In modifying the educational system in accordance with the industrial wants of the country, the changes necessary do not entail any serious revolution. The great industries of the country are more or less localized in certain districts, and therefore the character of the special instruction need not be extensively varied. The textile manufactures of cotton, wool, flax and silk, and the engineering, machine-making, dyeing, printing, and the subsidiary trades connected with and dependent upon them, are grouped together in separate localities. The same may be said of the iron and steel, cutlery and hardware trades, shipbuilding, mining, and the chemical and pottery industries. In every school, without exception, drawing and appropriate elementary science should be taught. A course of instruction in the use of a few manual tools would be most useful to every school boy, with distinctive practical teaching where necessary, and theoretical instruction bearing upon the nature and properties of the various products connected with local industries. (12—CXXVIII, 563)

There is conclusive evidence that the wool industry of the country, affecting the means of livelihood of millions of her Majesty's subjects, has been quickened and developed by the timely extension of artistic, technical, and scientific knowledge among the designers, dyers, finishers, and others connected with the trade, through the grants of the Clothworker's Company. This and other City companies, by extending their wealth upon the promotion of technical instruction among the industrial classes of several of our towns, have acted as pioneers in demonstrating its advantages to our commerce, and the Government could not more surely benefit the interests of commerce and agriculture than by devoting a reasonable proportion of the taxes to the development of the skill and intelligence of the artisans of the country, by whose labor the taxes are raised.

Without necessarily following the model of the elaborately equipped schools of the Continent, the technical school of a manufacturing town should at least contain departments for science and art, with chemical laboratory, classrooms and lecture theaters, a library, a museum, and one or more departments with machinery or tools appropriate to the local industries. Teachers will be required for day classes in the various subjects, and for the evening classes which in this country naturally become the backbone of



FIG. 98. MUNICIPAL SCHOOL OF TECHNOLOGY, MANCHESTER

the system. But students need to be prepared for the technical classes, and for a time at least it would be desirable that the accommodations should be utilized as a day school, giving an ordinary education to advanced boys, supplemented by the teaching of art and science subjects appropriate to the wants of the district, with the addition of workshop practice and modern languages. . . . The technical departments should be arranged in accordance with the industrial requirements of the locality. (12—CXXVIII, 568, 569)

It came about, then, that the average technical school offered elementary courses in mathematics, science, art, mechanical drawing, building construction and shopwork, and that most of these schools specialized in one or a few technical sub-

jects, often giving quite advanced courses. For example, the Technical School at Leicester, in 1909, had a department of "technology of the boot and shoetrade" and a department of "technology of framework knitting" because Leicester was one of the chief centers of the boot and shoe industry and of hosiery manufacture. These departments occupied a large proportion of the floor space and were equipped with the most modern machinery. The Municipal Technical School at Rochdale, being in a textile center, gave a large amount of space to a well-equipped weaving room and to a laboratory for chemistry, dyeing, and bleaching. In the great Municipal School of Technology at Manchester, Fig. 98, facilities were provided for advanced instruction in many industries. The largest space was devoted to the textile industries, Fig. 99. Among the others were mechanical engineering, electrical engineering, brewing, baking, plumbing, printing, bookbinding, and photography.

64. **The National Association for the Promotion of Technical and Secondary Education.** In 1887, the editor of the *Westminster Review* said, "All great questions of recent times have been promoted by the establishment of organizations with definite aims." As examples, he mentioned those connected with the corn laws, the extension of suffrage, and primary education. Then he added that "all parties and classes who desire the prosperity of the country and the comfort of the people will wish God-speed to the work of the National Association for the Promotion of Technical Education." (12—CXXVIII, 576)

A meeting had been held in the committee room of the House of Commons, which was attended by the Marquis of Hartington, who was made president, the Marquis of Ripon, Professor Huxley, Sir Lyon Playfair, Sir Henry E. Roscoe, Sir John Lubbock, Sir Philip Magnus, Arthur H. D. Acland, Swire Smith, and other leading advocates of more practical education.

The objects of the Association were defined to be:

1. The coordination of the technical education of the country in accordance with the needs of the various classes of employers and employed.

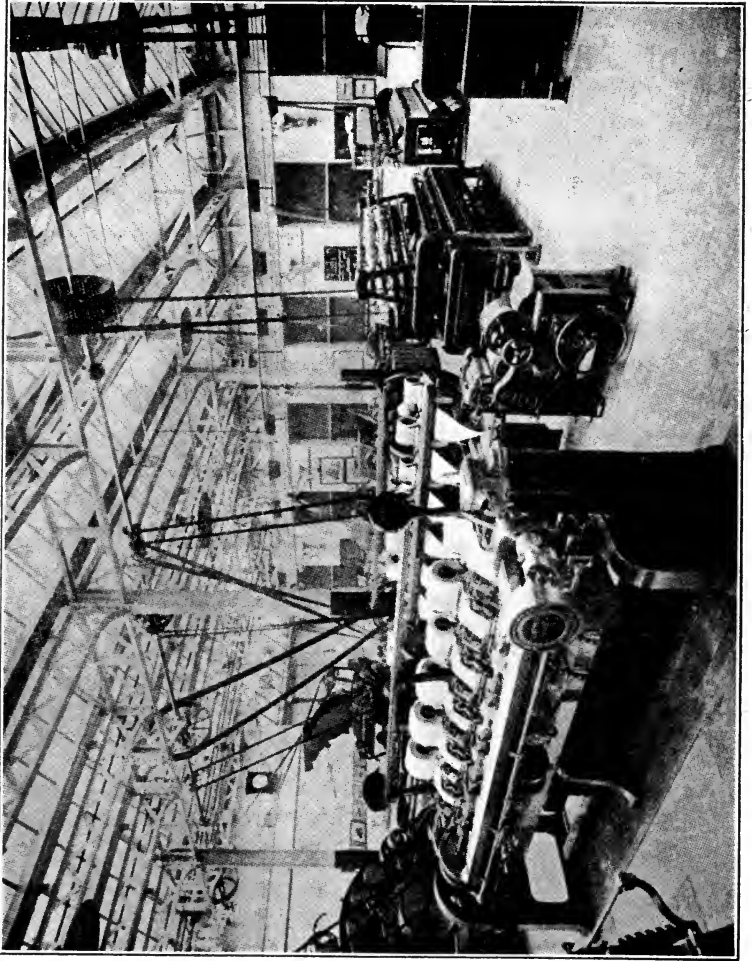

FIG. 99. COTTON SPINNING ROOM, MANCHESTER SCHOOL OF TECHNOLOGY

2. The foundation of a Board of Advice and Recommendation.
3. The spread of information as to the progress of technical education both at home and abroad.
4. The adaptation of schools to the industrial requirements of the several necessities of the working classes.
5. The removal of legislative disabilities, and the support of measures for the promotion of technical education in all its branches. (12—CXXVIII, 576)

This organization continued for twenty years—1887 to 1907—doing a work that proved to be most valuable.

Previous to this organization, there had been other less enduring and important ones and there had been the work and report of a Royal Commission, some of whose members became leaders in this National Association. The Royal Commission was appointed by Queen Victoria in 1881. It consisted of Bernard Samuelson, Henry E. Roscoe, Philip Magnus, John Slagg, Swire Smith, and William Woodall. Gilbert Redgrave was made secretary of the Commission. These commissioners visited the schools in the industrial centers on the Continent and in the British Isles. Their final report, published in 1884, consisted of five large volumes. This report was the basis for many of the discussions in the National Association. It was the most important source of information on the various phases of education for industrial workers. It is still the outstanding landmark in the history of industrial education. No other publication in this field, written in the English language, has ever been so influential, and none has been so widely quoted.

65. **Arts and Crafts Schools.** In order to understand the schools bearing the name Arts and Crafts in England, one must know something of the movement that gave birth to this name. The Arts and Crafts Movement was a reaction against the factory system of production and a revival of interest in fine craftsmanship. It grew out of the teachings of Thomas Carlyle (1795–1881) and John Ruskin (1819–1900). They cried out against mechanical duplication, against insincerity in art, and against the use of meaningless ornament. Art was not something superimposed; it was in the thing itself, in its proportions and structure. Beauty was not

merely in complexity but more often in simplicity. And an object to be really beautiful must be genuine—what it appeared to be. Ruskin believed that art was the product of man's joy in his labor. That being the case, art in its best form came from the unified creative effort of a single individual. Therefore the designer should be also the craftsman and the craftsman the designer.

The recognized leader in the movement to apply the teachings of Carlyle and Ruskin was William Morris (1834–1896). Associated closely with him throughout his life was the painter, Edward Burne-Jones (later Sir Edward) (1833–1898), whom Morris met at Oxford. Associated with these two in spirit and often in labor were Dante Gabriel Rossetti (1828–1882), painter, Phillip Webb, architect and designer, and several other artists and craftsmen.

In 1857, when Morris rented an unfurnished apartment in Red Lion Square, London, he was confronted with the practical problem of furnishing it. "The arts of cabinetmaking and upholstery had at this time reached the lowest point to which they have ever sunk," says J. W. Mackail. "Ugliness and vulgarity reigned in them unchecked. While he lived in furnished rooms it was easy to accept things as they were; but now, when furniture had actually to be bought, it became at once clear that nothing could be had that was beautiful or, indeed, that was not actually hideous. Nor was it possible even to get so simple a thing as a table or chair, still less any more elaborate piece of furniture, made at the furnishing shops from a better design." (13—I, 112, 113)

This designing and construction of the furniture for a room was the first of two furnishing problems worked out by Morris and his associates. The second was the famous Red House on Bexley Heath, near the village of Upton, into which Morris moved in 1860 shortly after marriage. The house and many of its furnishings were designed by Phillip Webb. The building itself, being of red brick, and quite unusual in design, was a protest against the practice of the time and, when it came to furnishing such a home, nearly everything had to be redesigned to satisfy its owner's sense

of what was beautiful and structurally good. "Only in a few isolated cases," says Mackail, "such as Persian carpets, and blue china or delft for vessels of household use, was there anything then to be bought ready-made that Morris could be content with in his own house. Not a chair, or table, or bed; not a cloth or paper hanging for the walls; nor tiles to line fireplaces or passages; nor a curtain or a candlestick; nor a jug to hold wine or a glass to drink it out of, but had to be reinvented, one might almost say, to escape the flat ugliness of the current article." (13—I, 143)

The artists and craftsmen who assisted Morris in this work joined him in a business establishment announced as "fine art workmen in painting, carving, furniture, and metals." Much of the early work of this company was in the field of church decoration. Later Morris developed a shop for weaving and dyeing at Hammersmith, a suburb of London. By 1881, the work of the company had changed so much that "weaving, dyeing, and cotton printing" were its principal products. About this time more space and better working conditions were needed and so the business was transferred to "picturesque and prettily weathered workshops" near the site of Merton Abbey. Here announcement was made that the following were being designed and made by this company of art-craftsmen: "(1) Painted glass windows, (2) arras tapestry woven in the high-warp loom, (3) carpets, (4) embroidery, (5) tiles, (6) furniture, (7) general house decorations, (8) printed cotton goods, (9) paper hangings, (10) figured woven stuffs, (11) furniture, velvets, and cloths, (12) upholstery." (13—II, 37) To this, there was added later the printing of beautiful books, the shop for this purpose being known as the Kelmscott Press.

Thus there came together a group of artists and highly skilled craftsmen working in various fields, most of whom acknowledged William Morris as their master. In this connection, it is significant that, early in his career, Morris had adopted two principles: "the first, that nothing should be done in his workshops which he did not know how to do himself; and the second, that every form of decorative art

could be subsumed under the single head of architecture, and had only a real life and intelligible meaning in its relation to the mistress-art, and through the mistress-art to all the other subordinate arts." (13—II, 197, 198)

With this ideal of architecture as the unifying center of many art-crafts, there grew up a community of interests which "demanded some visible expression," and, in 1884, the Art Workers' Guild was established in London. One of the purposes of the Guild was to hold monthly meetings and periodical public exhibitions, in connection with which instruction by acknowledged masters would be given in the theory and practice of the various handicrafts. Two years later, certain members of the Guild, working with representatives of other organizations, constituted a provisional committee of twenty-five for the purpose of forming an organization strong enough to support a comprehensive annual exhibition of the work of art-craftsmen. This organization was first named The Combined Arts; but, at the suggestion of Cobden-Sanderson, the bookbinder, its name was soon changed to Arts and Crafts Exhibition Society. Walter Crane, noted designer and author, was made its president and he retained that office through many successful years of the Society's work. From the naming of this organization, which was founded in 1888, the term "Arts and Crafts" has been the term most generally applied to the movement in both Great Britain and America which has had for its purpose the carrying into practice of the teachings of William Morris and his associates with reference to art in the common things of daily life.

The popularity of the arts and crafts exhibitions increased the demand for a higher type of art products and for more and better instruction in the art crafts. In the year 1896, the London County Council made provision for instruction in design and in several handicrafts in temporary quarters in Regent Street. In 1908, this school, known as the Central School of Arts and Crafts, was transferred to its own new building in Southhampton Row. Fig. 100. An important fact about this school is that it was intended to supplement

rather than to take the place of apprenticeship. It was primarily for students who were already engaged in some art industry, not for those who wished to get into such an industry. Instruction was given in design, and practice work provided in branches of the craft where it was not usually obtainable in the ordinary routine of production workshops.



FIG. 100. CENTRAL SCHOOL OF ARTS AND CRAFTS, LONDON

A large majority of the students were therefore in the evening classes. However, two technical day schools for boys have been added to the work of the school. (Source Material VIII A)

The prospectus of 1914-1915 reveals the scope of the instruction:

1. School of Architecture and Building Crafts
2. School of Cabinet Work and Furniture
3. School of Silversmith's Work and Allied Crafts
4. School of Book Production
5. School of Drawing, Design, and Modeling
6. School of Decorative Needlework

7. School of Stained Glass, Mosaic, and Decorative Painting
8. Special Lectures and Demonstrations
9. Day Technical School for Boys in Book Production
10. Day Technical School for Boys in Silversmiths' and Jewelers' work

This great school of arts and crafts was developed under the principalship of W. R. Lethaby, author of *Form in Civilization*³ and many papers on the art-crafts and their relation to modern life. Another school of the same type, the Camberwell School of Arts and Crafts, is located in the southeast section of the city. In 1909, this school was doing outstanding work in masonry and stone carving.

66. Junior Technical Schools. In the British Isles what has come to be termed the junior technical school is a special secondary school giving a general industrial training to boys who are expecting to become apprenticed to some mechanical trade. It is intended to provide a brief and better secondary schooling for such boys than a school that gives no attention to shopwork and less to drawing. It is definitely a pre-apprenticeship school; it is sometimes called a preparatory trade school. It occupies the two or three years from the ages of 13 or 14 to 16. The minimum age of entrance is 13. At the end of the course, each boy, with the advice of his teachers and parents, is expected to select a trade and serve an apprenticeship in that trade, and at the same time continue his education in an evening or continuation school. In some trades, credit for two years on a seven-year apprenticeship is given to graduates of a junior technical school.

Junior technical schools are periodically inspected by officials of the Board of Education, and money grants are based on the reports of these officials. The usual grant to efficient schools in 1914 was £5 per pupil per year:

The course of instruction in the Junior Technical School at the Toxteth Technical Institute, Liverpool, in 1914, was outlined in hours per week as follows:

³Oxford University Press, London, 1922.

- English subjects, 5
- Science subjects, 5
- Practical mathematics, 5
- Geometry and freehand drawing, 5
- Workshop practice and theory, 9
- Physical exercises, 1

The instruction in science, mathematics, and much of the drawing grows out of, or is closely related to, the shopwork. The English subjects include commercial geography, industrial history, and elementary economics, as well as language and literature. The shopwork includes both woodwork and metalwork. It is outlined as follows by George Thompson in an article, "Prevocational Education in England":

The metalwork course provides:

(a) A series of manipulative exercises in iron, steel, copper, brass, and zinc, thus covering the whole range of the common metals and alloys, and thereby familiarizing the pupils with malleability, ductility, brittleness, hardness, and general suitability of metals for constructional purposes.

(b) The opportunity to acquire skill in the use of the hand tools found, in a modern metal workshop, by means of exercises involving filing, chipping, surfacing, fitting, calibrating, forging, hardening, and tempering. Tool features are discussed and analyzed.

(c) Experience with the drilling machine, grinder, and turning lathe sufficient to familiarize the students with such essential machinery features as: variation of speed for different metals, belt driving from pulley to counter-shaft, cogwheel gearing, screw cutting, boring, utility of chucks, besides granting the opportunity for the study of machines as a multitude of parts, which when working in harmony make a real "live thing" and an accomplished labor-saving agent.

The woodwork course provides:

(a) A wide range of graduated exercises and models in wood of different varieties, sufficient to illustrate the importance of timber in construction and its superiority over all other materials for specific purposes. Pupils are encouraged to suggest, and design, then execute work according to their experiences.

(b) The means whereby dexterity in the use of edged tools may be gained through planing, sawing, chiseling, gaging, and boring. The joints standardized by the joiner, cabinetmaker, and patternmaker are employed as examples.

(c) Opportunity for the pupils to gain experience in the working of high-speed machinery; the need for special lubrication.

(d) A training in use and care of cutting tools, including paring, incising, abrading, and boring tools. From the early stages pupils are encouraged to sharpen and set all tools. (14—III, 247)

How long the junior technical school will remain a vital part of the technical education system of England is not yet clear. With the further development of secondary schools, this school may lose its identity in the larger scheme. But its origin and early growth is quite typical of the development of technical education generally in England; it grew out of local conditions where there was no adequate system of secondary schools.

SOURCE MATERIAL VIII, A

TRADE SCHOOLS OF LONDON

By Dr. C. W. Kimmins, Chief Inspector of Schools, London County Council. Paper read before the British Association at Winnipeg, 1909.

From *Educational Handwork*, Vol. III, No. 13, pp. 109—112.

Before entering on the question of trade schools, I should point out that, in London under the London County Council, there is a very elaborate scholarship scheme consisting of Junior, Intermediate, and Senior scholarships which makes ample provision for all the children of exceptional ability in the elementary schools. The normal age of competition for the Junior scholarships is between eleven and twelve years of age, but arrangements are now being made for a further contingent at the age of thirteen for children who develop later than the normal child.

When a Junior scholarship is won, the child is transferred from the elementary to a secondary school in which he or she receives free education with a small maintenance allowance at first, which increases considerably at the age of fourteen when, under ordinary conditions, the child might leave the elementary school. If the scholar does well in the secondary school, the Intermediate scholarships, which are of higher value, are open for competition, and the child who is successful may remain at the same secondary school or be transferred to one of higher grade and receive, in addition to free education, a higher maintenance allowance than he received as a Junior scholar. Further, if successful in obtaining a Senior scholarship, the boy or girl may go on to Oxford or Cambridge, or technical institutions of university rank in England, or abroad for a period of three years with a very substantial maintenance allowance. Thus a pupil may be on the scholarship ladder for over ten years and pass from the elementary school to the secondary school and afterward graduate at one of the ancient universities with practically no cost to his parents since he left the elementary school.

The number of scholarships awarded in each stage is large and will probably be increased still further by the Council, should the necessity arise. It may, therefore, be taken for granted that ample provision is made for the specially gifted child, however poor its parents may be. The examinations on which these scholarships are won are based on the ordinary subjects of instruction. In addition to the general scholarship scheme, special provisions are made to encourage and endow artistic ability. Scholarships of increasing value are given to students of special promise, and in a scheme now under consideration provision is made for the award of art scholarships to the value of £50 a year, tenable for three years.

The brilliant child is therefore well provided for and may eventually become fully equipped for one of the learned professions or one of the higher walks of industrial life.

Other children, though not sufficiently brilliant to gain scholarships for secondary schools at the age of eleven, may be sufficiently clever to be transferred to a higher school of elementary type at the age of twelve and there obtain, though not a trade education, education of a more or less

specialized type, and with a higher leaving age than is the case at the ordinary elementary school.

After thus making provision for the abnormal child, the problem of problems becomes, How can we prevent the boy or girl of normal intelligence from drifting into the ranks of unskilled labor at the age of fourteen? The difficulty here is seriously increased by the fact that there is not the slightest difficulty in a healthy, moderately well-educated, well-conducted child finding employment at a rate of remuneration which for a child of this age appears very liberal indeed. The point is, however, that, in the vast majority of cases, such employment does not lead to advancement financially or otherwise; and in a few years' time, after the child has deteriorated intellectually and is less well educated than at the time of leaving school, the employment for which young children are better suited comes to an end and the boy or girl sinks into the ranks of the unemployed or into the lower departments of unskilled labor. It has been found that for the poor type of child it is, under present conditions, quite impossible to insure two or three years' continuous instruction after the age of fourteen unless some grant for maintenance is made which will recoup the parents for the loss they sustain by not letting their children enter unskilled employment.

In order to bridge over the serious gap between the ages of fourteen and seventeen, a new type of school, the trade school, has come into existence, which is destined in the future to play a very important part in London education.

The origin of this type of school is due to the changed conditions of modern industry and the total disappearance in some, and the gradual disappearance in others, of the apprenticeship system in many of the London industries. The trade school movement has been much influenced more recently by the desire expressed by both employers and employes of the bookbinding and printing trades and the goldsmiths', silversmiths', jewellers', and allied trades for better preparation in technical and artistic preliminary training of boys before entering the workshop and while serving apprenticeship, with a view eventually to raise the standard of work in their particular crafts. This interest has been shown by employers by their keen desire as members of consultative committees to assist the Council with advice in various ways. In the past, there was no connection between day schools and the trades and industries of London. These trade schools are now supplying this link. The pupils attending are classed as (1) fee paying, (2) those that have been awarded free places, and (3) scholarship holders with maintenance allowance. It is interesting to note with reference to the latter the great increase in the number of scholarships granted by the London County Council for these schools. In 1905, there were 32; in 1906, there were 310, including 80 for girls to enter the girls' trade schools; while, in 1909, 610 have been authorized, of which over 300 are for girls. The competition for these scholarships is very keen indeed. Thus at the last competition for 90 of these scholarships which carry maintenance allowances of £6 per year for the first year, £6 or £10 for the second, and £15 for the third, there were 534 candidates.

The course in the trade schools for boys lasts three years and the general principle that underlies the instruction given is that the pupils' general

education is continued and closely co-ordinated with the particular craft work taught. The amount of time devoted to craft work is about half the total, from about one third in the first year to two thirds in the last; and this is taught in a way which is generally educational as well as preparatory to the future occupation of the boy. The staff consists of a headmaster, a chief technical instructor, and assistants who are specially selected and are experts in the particular art or craft they teach and who have also had a workshop training. The staff includes a science, an art, and an English master.

The following schools work with the definite object of preparing boys for entering specific industries. In the Shoreditch Technical Institute, which has a great reputation as a technical school for the furniture trades and is one of the oldest established of the London trade schools, the maintenance grant is £6 for the first year, £10 for the second, and £15 for the third year, the increase in value from year to year being for the purpose of meeting increased temptation on the part of the parents to make the boy a wage earner. The course for furniture and cabinetmaking at this school consists of English subjects, arithmetic and mensuration, geometry and geometrical drawing, freehand and model drawing, design work associated with wood and metal, modeling in clay, elementary experimental science, workshops and technical drawing, technology of woods and metals, and a large amount of benchwork for the use of woodwork and metalworking tools. The time allotted to the theoretical and practical workshop lessons is roughly equal to that allotted to the English, mathematical, and science subjects. This school prepares boys to enter the furniture and woodwork trades as cabinetmakers, carpenters, joiners, shop fitters, patternmakers, turners, wood carvers, or trade draughtsmen.

In the Central School of Arts and Craft, which is far and away the finest school of this type in England, there is a special day department to prepare boys to enter some branch of the silversmithing trade or kindred crafts in silversmiths', goldsmiths', or jewellers' work as tracers, engravers, mounters, draughtsmen, etc. Next session, there will also be a book-production school in this building, which will give suitable training for boys entering the printing and bookbinding trades. In this school, it has been arranged that, at the end of the first year, the boy shall be apprenticed to firms of good standing; and the time spent at the school after the boy is fourteen years of age will count as part of the period of apprenticeship. The course of instruction will extend over three years, from thirteen to sixteen.

Another interesting school, also under the control of the Council, is the Brixton School of Building, which prepares boys for the building trades and allied professions. In this school, boys may qualify as bricklayers, masons, plumbers, painters, architects, builders, and surveyors.

Another trade school which is doing excellent pioneer work is housed in the Borough Polytechnic. In this school, the boys have the advantage of working in well-equipped laboratories and workshops used by adult students in the evening classes. This school, while not preparing for any specific trade, gives a general training extending over three years for boys entering the various branches of the engineering trade or any kind of metalwork. It is probable that schools of a similar kind will be established in other polytechnics in which there is sufficient accommodation for a school of this type during the day time.

At present, most of the trade scholarships for boys are awarded in engineering, silversmithing, bookbinding, furniture and cabinetmaking, carriage building, wood carving, and for the building trades.

The scholarships awarded to girls are for trade dressmaking, laundry work, upholstery, ladies' tailoring, waistcoat making, corset making, millinery, designing and making of ready-made clothing, and photography. As a rule, trade scholarships for girls are for a period of two years with a maintenance grant of £8 for the first year and £12 for the second year, in addition to free education.

The most important day trade school for girls is the London County Council's school at Bloomsbury. Here there are about one hundred and fifty girls in the first or second year of the course of training. The subjects taken at this school are corset making, dressmaking, ladies' tailoring, millinery, and photography. In all departments, there are trade teachers. A very special feature is the art instruction at this school, which has for its object not only the acquiring of technical skill in the drawing required in various departments, but the general cultivation of a refined artistic sense, which is of much importance in all grades of trade work. Two thirds of the time of this school is devoted to trade instruction and the remainder to the general education of the pupil, with special reference to the requirements of each trade. The subjects of instruction in general education include English, arithmetic, drawing, hygiene, and physical exercises. The school is open five days a week from 9 A.M. to 12:45 P.M. and from 1:45 to 5 P.M.

It is not necessary to enter into any further description of the trade schools for girls as they are based in almost every particular very largely upon the model of the *Ecole Professionnelle* of Paris, with the exception that, in Paris, maintenance grants are very rarely given and in London a very large proportion of the girls in each school are scholarship holders.

The fees for the trade schools are very low so that candidates who are unable to obtain scholarships may attend at very small cost; and, in many cases, where candidates have acquitted themselves creditably, at the examination, they are allowed free places at the schools, though they may have failed to obtain scholarships which carry with them maintenance grants.

In order to insure that trade scholarships are given only to children of parents who are unable to maintain their children at school without assistance, no candidate is eligible whose parents or guardians are in receipt of an income which exceeds £160 a year from all sources. In order to prevent scholarship funds being wasted, the awards are conditional on the candidates passing a satisfactory probationary period of three months at the trade school with no payment for maintenance but simply free tuition; and if, at the end of the period of probation, an unsatisfactory report on the scholar is received, the scholarship is withdrawn. The parents or guardians of scholars are, moreover, required to sign a declaration that they intend the scholars to enter the trade in which they have received training during the tenure of their scholarships. These safeguards work very satisfactorily and the result is that a very large percentage of scholarship winners find permanent employment in the trades for which they have been prepared. . . .

As stated above, the decay of the apprenticeship system has been an important factor in necessitating the establishment of trade schools in which

boys or girls may become sufficiently skillful to enable them to enter with intelligence into any department of the workshop in which they may be placed. The trade school, moreover, has a distinct advantage over the old system of apprenticeship for the following reasons:

1. The supervision in a well-equipped trade school is generally of a much more efficient order than even that of a well-ordered workshop.
2. Culture subjects are not neglected, and consequently the general education of the boys or girls is continued in a manner suitable to the trade for which they are preparing.
3. In the apprenticeship system, there is a natural tendency for the apprentice to become attached to some special department of the work to the serious neglect of others.
4. In following out a definite curriculum under a well-arranged timetable, there is a very little waste of time, and the balance of theoretical and practical work is properly maintained.
5. The work of a trade school is generally governed by a consultative committee of experts who are to a large extent responsible for the education of the students being carried on under the best trade conditions.
6. The presence of trade experts with experience of teaching, who are always at hand in the workshop and able to solve any difficulties which may arise, means an enormous saving of time as compared with the case of the apprentice who has to wait the convenience of the foreman for the solution of difficulties.

It thus happens that the boy who has had a continuous course of instruction in a good trade school for a couple of years may have acquired as much skill and knowledge as one who has worked for four years under the conditions attached to an apprenticeship. Of recent years, there has been an enormous advance in London in the establishment of trade schools and in the facilities offered to students of all grades who are anxious to enter the various trades.

The movement with regard to trade schools would have been doomed to failure if employers had not realized the great value of the course of instruction received. The result is that there is no difficulty in finding employment for those who have satisfactorily passed through a full course of training, and it is generally found that, in periods of depression, the more skilled students from the trade schools retain their employment when others are dismissed. A very important development in connection with trade schools is the establishment of "Voluntary After Care Committees," the members of which interest themselves in the scholars at the trade schools and take an interest in them after they have been successfully placed in workshops. A committee of this kind is of extreme value, as it can obtain information as to the conditions of work in the various shops and can give valuable assistance to those who are seeking employment; and, moreover, where short periods of apprenticeship are arranged, it can see that, under the conditions of the indentures, the interests of the boys and girls are safe-guarded.

A most important element in the success of the trade schools is the alliance of the school with the trade by means of the expert consultative committee. The arrangements which have been found to work very smoothly in London are based on the following regulations:

1. A consultative committee of trade experts shall consist of an equal number of:

(a) Representatives of the Council to be selected as far as possible from well-known experts in the subject concerned, or persons of experience in the administration of technical education.

(b) Representatives of the trade, one half of whom shall be representatives of the employers and one half of the employees.

2. The representatives of the employers and employees shall be appointed on the respective recommendations of the leading associations of employers and trade unions of the industry concerned.

3. The chairman of the consultative committee shall be nominated by the council from among the Council's representatives.

4. The consultative committee shall act solely in an advisory capacity.

It will be seen by the above regulations that the functions of the consultative committee are nominally advisory only; but, as a matter of fact, committees dealing with the proposals of the consultative committees give great weight to their well-considered decisions and, unless this were done, it is highly probable that the businessmen holding important positions, who now serve on the consultative committees, would cease to act.

An important point arises in regard to the trade school, and that is to the ultimate effect that a general intimate connection with trades may have upon the artistic side of the trade-school work, the standard of taste which prevails in many trades being far from ideal and the general conditions not being altogether conducive to the development of the artistic faculty of the craftsman. It is a matter of extreme importance that this danger should be carefully watched and provision be made to provide facilities and opportunities for the free artistic development of the persons engaged in the various crafts. The great safeguard against such a downward tendency is in the work of the fine arts, and arts and crafts schools where the attendance at classes is not in any way restricted to people engaged only in a trade or industry. These schools, however, give an artistic training, and, in the case of arts and craft schools, also provide practical teaching of some of the crafts in properly fitted workshops. The majority of the classes in these schools, however, are untrammelled by commercial or trades considerations and are, therefore, enabled to work out high ideals and to serve a most useful purpose in assisting to lead and cultivate the public taste and to give a knowledge of and create the desire for beautiful things. In fact, they may largely be regarded, to some extent at any rate, as culture classes. It is useless making beautiful things unless there is an appreciative public.

In connection with these schools, there is an excellent scholarship scheme by which promising artistic material may be given every facility for development under favorable conditions without financial embarrassment. Some of the scholarships thus open for competition are tenable at the most renowned art schools in London.

In addition to the full-time trade schools, there are many polytechnics and technical schools in London working in conjunction with employers of labor in connection with the part-time education of certain grades of their employees. Thus boys at the Royal Arsenal at Woolwich, for example, attend for instruction at given times at the Woolwich Polytechnic, all expenses being

borne by the War Office. Similarly, the apprentices in the engineering shops of the South Western Railway Company attend day classes at the Battersea Polytechnic.

In connection with the silversmithing trades, in addition to free education for selected apprentices, bursaries are granted by the London County Council at the rate of 8d. an hour for time spent in technical instruction at special day classes in connection with the silversmiths' craft. These bursaries cover travelling expenses and the apprentices' loss of time from their work. Arrangements of this kind are capable of unlimited extension.

In conclusion, another point should be made in connection with this subject, and that is the admirable provision made in all parts of London for evening classes in polytechnics and similar institutions in connection with the various trades. These classes are strictly limited to students who are already engaged in the trade, and are taught by teachers who hold important positions in their craft. The enthusiasm with which thousands of young artisans after a long day's work will attend for theoretical and practical instruction in the scientific principles of their trades under skilled craftsmen is one of the most pleasing features in London education.

SOURCE REFERENCES

1. *Fortnightly Review*, Chapman and Hall, London.
2. *Nineteenth Century*, Kegan Paul, Trench & Co., London.
3. *Second Report of the Royal Commissioners on Technical Instruction*. London, 1884.
4. Balfour, Graham. *The Educational Systems of Great Britain and Ireland*. The Clarendon Press, Oxford, 1903.
5. *Cornhill Magazine*, London.
6. Mill, Dr. John. *What is Industrial and Technical Education?* (Pamphlet) Simpkin, Marshall & Co., 1871.
7. Millis, C. T. *Technical Education—Its Development and Aims*. Longmans, Green & Co., London, 1925.
8. *Report of the Commission on Industrial Education* made to the Legislature of Pennsylvania, Harrisburg, 1891.
9. Magnus, Sir Philip, *Educational Aims and Efforts*. Longmans, Green & Co., London, 1925.
10. Hogg, Ethel M. *Quentin Hogg, A Biography*. Archibald Constable & Co., London, 1904.
11. Watson, Foster. *The Encyclopaedia and Dictionary of Education*. Sir Isaac Pitman & Sons, Ltd., London, 1922.
12. *Westminster Review*. Taubner and Company, London.
13. Mackail, J. W., *The Life of William Morris*. Longmans, Green and Co., London, 1901.
14. *Vocational Education*, The Manual Arts Press, Peoria, Ill.

CHAPTER IX

THE EARLY DEVELOPMENT OF PEDAGOGICALLY ORGANIZED SHOPWORK INSTRUCTION IN THE UNITED STATES OF AMERICA

67. Shopwork in the Worcester County Free Institute.

While the development of industrial education in the United States was influenced by the important changes as they took place in Europe, the process of evolution was simpler than in England because, from early Colonial times, the principle of elementary education for everybody and free public schooling for the poor was well established.¹ Thus, in principle, at least, elementary general education being provided chiefly by the State, the educational problems left for individual, philanthropic, and association efforts were those of secondary, professional, and industrial education. By 1870, the Mechanics Institute Movement, beginning in 1820,² had done an important work in providing considerable instruction in secondary and technical education subjects. The most famous of these institutes were the Franklin Institute of Philadelphia, the General Society of Mechanics and Tradesmen in New York City, and the Ohio Mechanics Institute in Cincinnati. In 1827, the Gardiner Lyceum, Gardiner, Maine, had led the way toward higher education in applied science by offering a three-year curriculum including surveying, navigation, mechanics, agricultural chemistry, and civil engineering. The Rensselaer School, founded in 1824, had become the Rensselaer Polytechnic Institute, America's most famous school of civil engineering. The Sheffield Scientific School had been established at Yale College in 1847, the Lawrence Scientific School at Harvard College in the same year, and the Chandler Scientific School

¹ Bennett, Charles Alpheus. *History of Manual and Industrial Education up to 1870*, p. 269.

² *Ibid.*, pp. 317-325.

at Dartmouth College in 1852.³ The famous Land-Grant Act had been passed in 1862 providing for the endowment of higher education in agriculture and the mechanic arts.⁴

All this development in applied science was yielding results in the industries of the nation but there remained the increasingly important work of training more engineers, designers of machinery, factory managers, and other masters of both scientific principles and practical details. Such training involved instruction in the mechanic arts and the processes of manufacture as well as in mathematics and science. The first institution to make adequate provision for such instruction was opened in 1868. This was the Worcester County Free Institute of Industrial Science, later known as the Worcester Polytechnic Institute, at Worcester, Massachusetts. This new type of American school was made possible by the offer of Ichabod Washburn to establish a machine shop as one of the departments of the Institute. There were two vitally important factors in the plan for this shop: (a) It was to be run as a commercial shop, producing articles to be sold. (b) The shopwork was to be done by the students in order to learn how to do it; no pay was to be received for the work done.⁵ There was, therefore, a wholly educative purpose in giving the shopwork training. The money received for the products of the shop was not expected to pay all the expenses of the shop. The shopwork was to be on essentially the same educational plane as the laboratory work in science. The point of view of the founders as expressed by the first president of the Institute, Charles O. Thompson, is as follows:

This demand for mechanical engineers with workshop training, and the practical impossibility of finding a place for a boy in any machine shop, led to the establishment of a polytechnic school in which a manufacturing machine shop is a prominent and thoroughly administered feature. . . .

This institution was organized under the influence of a belief that, after all that has been done in technology, there is still need of a system of training boys, broader and brighter than "learning a trade," and more simple and

³ *Ibid.*, pp. 348-353.

⁴ *Ibid.*, pp. 353-358.

⁵ *Ibid.*, pp. 358-362.

direct than the so-called "liberal education"; that, while the boys should be thoroughly trained in all the essentials of a polytechnic course, they should also find a workshop open where they could get all the essentials of a trade; so that, upon graduating, they should have sufficient knowledge of machinery and handicraft to enable them to earn a living while pushing their way up to the highest positions for which nature and their training had qualified them. It was held that not the least important of their qualifications for high positions is a good experience in the lower positions. (1—IV, 726)

The instruction included patternmaking and the elements of cabinetmaking as well as machinist's work. The claim was made, and apparently justified, that combining the shopwork and the other studies in one course was advantageous to both. But concerning the organization of the subject matter and teaching methods in the shopwork at the Worcester school, there is no available evidence that these had gone beyond those of the best apprenticeship of that time. In fact, Mr. Washburn, in his letter of gift said:

There shall be a machine shop of sufficient capacity to employ twenty or more apprentices, with a suitable number of practical teachers and workmen in the shop to instruct such apprentices, and, provided with all necessary steam power, engines, tools, apparatus, and machinery of the most improved models and styles in use, to carry on the business of such machine shop in all its parts as a practical working establishment. There shall be a superintendent of such shop, who shall be appointed and subject to be removed by the trustees; who shall be a man of good morals and Christian character, having a good English education, a skillful and experienced mechanic, well informed and capable of teaching others in the various parts and processes of practical mechanism usually applied and made use of in the machine shops of the country; who shall devote his time and attention to the management and business of the shop, purchasing stock, making contracts for the manufacture and sale of machines, and other work usually done in machine shops, subject to such rules as the trustees may prescribe, and having charge of the proper financial concerns of the shop, hiring necessary workmen and discharging the same at his discretion; and shall see that the apprentices are suitably taught in all the departments of practical mechanism, working in woods and metals, and use of tools, so as to make them, so far as it may be, skilled workmen, and fitted to carry on business for themselves after they leave the shop, at the expiration of their apprenticeship.

He shall, moreover, have a care and oversight over the apprentices, such as a faithful master would exercise, to the end that they may cultivate habits of industry, good conduct, and attention to their studies. (2—152, 153)

Neither the ideal set forth in this letter of gift nor the statement previously quoted from President Thompson in-

dicates that the teaching in the shops of the Worcester school during those early years was based on any adequate or even conscious analysis of either tool processes or of the trade or industry as a whole in which the students were receiving instruction. The teaching was done by the imitative, do-it-as-I-do method of apprenticeship.

Almost immediately following the establishment of the shopwork in the Worcester school, several other engineering schools took similar action, though some of them with different aims and much less equipment. In 1870, at the Illinois Industrial University, later the University of Illinois, woodworking was taught to students in architecture, and ironworking to students in mechanical engineering. The purpose of this shopwork was not to teach trades but "to be simply illustrative of the principles of mechanical engineering which are taught in the classroom." "With the aid of students, Professor S. W. Robinson manufactured an eight-horse-power engine and the most important furniture of a machine shop," whatever that may mean. "The carpenter shop contained benches, sets of tools, a buzz saw and jig saw, a mortising machine, a wood-turning lathe, etc." Besides manufacturing machinery, many pieces of experimental apparatus were made, also models of bridges, roof trusses, and the like. All shopwork was done from working drawings. (3—104, 105) The "apparatus, implements and machinery, models, drawings, and designs". . . . "even the neat walnut cases" shown in the exhibit of the Illinois Industrial University at the Centennial Exposition at Philadelphia in 1876, were made by the students in the shops of the University. (4—VIII, 25)

Stevens Institute of Technology at Hoboken, New Jersey, included shopwork in its course of study from its opening in 1871. The shopwork of this school, shown at the Centennial Exposition, consisted of "finished machines and instruments." (4—VII, 515)

68. Early Shopwork at the Kansas State Agricultural College. While all the colleges established under the Land-Grant Act of 1862 were intended to give special attention to

instruction in agriculture and the mechanic arts, they varied greatly in the courses they offered during their early years, depending somewhat upon the needs of the state but more upon the ideals, vision, and capacity of the men who were placed in positions of responsibility. At first, some of these colleges were agricultural and industrial hardly more than in name, while others developed quite comprehensive courses in these newer phases of higher education. As already stated, the Illinois Industrial University, established under the Land-Grant Act, early developed courses in engineering and architecture, and, in connection with these, instruction in shopwork. At the Kansas State Agricultural College, courses in shopwork were more definitely on a trade level. A student might pursue one kind of shopwork for four years and so go out with the essentials of a trade as well as his education in science, mathematics, and literary subjects; or, as recommended for students in the agricultural course, he might divide his industrial time among several shops. As early as 1874, there was a carpenter shop, a wagon shop, a blacksmith shop, a paint shop, a turning shop, "a scroll-sawing, carving, and engraving shop," a printing department, and a telegraph department. There was also a department of drawing. For young women, there was a department of sewing, work in household economy, and a very progressive course in household chemistry. Besides these, the young women were allowed to take courses in drawing and do shopwork in scroll sawing, carving, and engraving.

In the college handbook for 1874, the statement concerning the instruction in carpentry and the equipment of the carpenter shop was as follows:

Each member of the class is furnished a bench, materials for practice, and a case of the best tools, the key to which he retains. The Institution bears ordinary wear; extraordinary damage or loss of tools would be charged to the student—none having yet occurred.

The pupil is taught the uses and names of tools, required to put and keep them in order, and carried through regular practice in sawing, planing, tenoning, mitering, house framing, building, and finishing. After acquiring sufficient skill, he is permitted by the superintendent to employ the industrial hour in making articles for his own use, paying for the material at cost price.

Tables, office desks, bookracks, and entomological cases are more commonly chosen, thus requiring the careful workmanship of the cabinet shop. Pupils learn more rapidly when at work on something they themselves want, and when receiving the profit on their own labor; and, as our sole purpose is to develop the skill of the student, every encouragement is given. It is confidently believed that, after a boy has acquired market skill, and after experience has shown what articles yield the best profit in Kansas, second- or third-year students will, in this manner, be able to earn better wages than as teachers, and at the same time support themselves in college.

Besides the general set of tools, there are twenty-six student's kits. Each kit contains thirty-five pieces as follow: Rule; try square; level; scribe awl; compasses; marking gauges; chalk line and reel; hatchet; drawing knife; rip-, crosscut and tenon saws; jack, jointer, and smoothing planes; firmer chisels, framing chisels; screwdriver; bitstock and bits; winding sticks; bench hooks. (5—97, 98)

From the statements concerning the other shops, the following are quoted:

Wagon Shop. Instruction in the wagon shop embraces names, uses and care of tools; sawing, and dressing spokes, fellies, axletrees, tongues, hounds, and boxes; turning hubs; building harrows, wheelbarrows, farm and spring wagons. The equipment is complete, and the wagon and blacksmith shops are under the same roof. (5—98)

Blacksmith Shop. The full equipment of tools has been furnished, and the instruction and practice include management of bellows, striking with sledge, cutting threads on bolts and nuts, use of hand hammer in drawing down iron and sharpening plows, fitting and nailing horseshoes, ironing wagons, setting tires, making tools, etc. (5—98)

Paint Shop. Preparing work for painting, mixing colors, manner of applying, making putty, staining, graining, and varnishing. A complete stock of tools and materials. (5—98)

Turning Shop. A splendid foot and power lathe, with complete attachments for doing all kinds of wood and metal turning, has been received from the machine shop of the Worcester Institute, and a class will begin practice in the January term of 1875. Instruction will embrace the care and use of tools; wood turning, plain and fancy; brass ditto; iron ditto. The lathe will be used by the advanced classes in the wagon and carpenter shops. Reasonable proficiency in drawing is required as a condition of admission to this "industrial." (5—99)

Printing Department. The office contains twenty-six pairs of cases, a corresponding supply of type, composing sticks, a "proof" press, and all needed facilities for practice. The student is taught the boxes, indention, capitalization, spacing, punctuation, etc. Several different drills are employed for the purpose of developing rapidity in composition, and the rules of book printing are enforced from the outset. A boy desiring to become a printer will find all appliances needed for acquiring expertness as a compositor, and, in addition, a course of thorough instruction in the English language, as used by the proof reader and editor; in bookkeeping adapted to subscription and

job accounts; and in drawing, as the best developer of that true and facile taste which is the backbone of success in job printing.

While he is an apprentice in an office, he cannot attend school; while attending school, he cannot be an apprentice. Here, he can obtain precisely those advantages of manual and intellectual education which are most directly valuable to the compositor. (5—101)

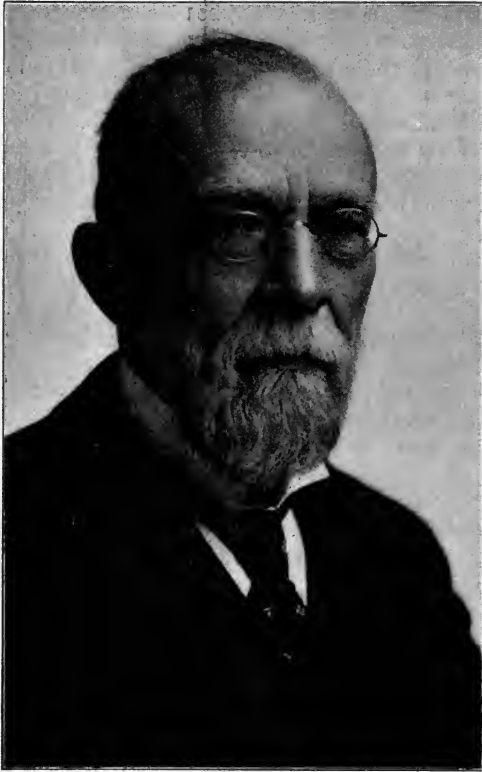

FIG. 101. CALVIN M. WOODWARD

Telegraph Department. Equipment is probably superior to that found in any telegraphic school in the United States. (5—102)

From many statements, of which the above are samples, it is clear that before the Centennial Exposition of 1876, held in Philadelphia, the Kansas State Agricultural College had developed a system of "industrials," which included practical agriculture, horticulture, several mechanic arts, or industrial arts, as they seemed to prefer to call them, a few commercial

subjects, and considerable work in the household arts for women. Some industrials were required of all students but there was considerable freedom of election. There was a very definite economic side to this work; students were often helped to earn college expenses through the industrial work or they were allowed to specialize in a single industrial to the point of learning a trade. The best of tools and equipment was provided. As to the methods of teaching, one might conclude from some of the announcements of courses that the arts taught had been quite fully analyzed and pedagogically organized; but one needs to be cautious in reaching this conclusion. For example, an early student at the college⁶ told the author of his experiences in woodworking. He said that about the first thing he did was to take a piece of black walnut, perhaps $2\frac{1}{2}''$ x $2\frac{1}{2}''$ x $30''$, and plane it square. This was later used as a table leg, being turned by someone else. There was no class instruction. Another student in the same class might be doing quite a different piece of work—perhaps planing a board. There were no class exercise pieces, as such. After he had demonstrated that he could use the tools, he was allowed to make whatever he wanted to make, paying for the materials he used. One of the more difficult things he made was a three-sided pyramidal plant stand for his mother. It was to fit into a bay window at home. It involved the application of a number of problems in mathematics and therefore careful planning and accurate work on his part.

During the early years, from 1871 to 1878, the shopwork instruction at the Kansas Agricultural College was under the direction of Ambrose Todd. The same general system was followed under his successor, Timotheus T. Hawkes. The more modern methods of a uniform course and the use of blueprints were adopted in 1887 with the coming of Ozni P. Hood as instructor in mechanics and engineering.

69. Professor Woodward's Early Experiments in School Shopwork. In the early seventies, Calvin Milton Woodward (1837-1914), Fig. 101, later to become the great American

⁶The vice-president of the College, Dr. Julius T. Willard, in 1932.

champion of manual training, was professor of mathematics and applied mechanics and dean of the Polytechnic faculty of Washington University. Professor Woodward was born in Fitchburg, Massachusetts, August 25, 1837. He graduated at Harvard University in 1860 with the degree of A.B. and membership in the Phi Beta Kappa fraternity. In 1865, he went to Washington University as vice-principal of the academic department and, in addition to filling this office, he taught freshman classes in mathematics in the College; in 1866, he was made principal of O'Fallon Polytechnic Institute, which offered many evening courses; and, in 1868, he was authorized to organize an engineering department for the University. His rich experience with boys in the preparatory school, young mechanics in evening classes, and university students seeking preparation for work in engineering, gave him a broad outlook upon practical education, which, with his unbounded vital energy, made him ready to solve new educational problems.

As professor of mathematics in the University, he taught a class in applied mechanics. Because his students found difficulty in visualizing some of the forms under consideration, he asked them to work out these forms in wood. He arranged with the college carpenter, Noah Dean, a fine mechanic, to supervise them in this work. To Professor Woodward's surprise, he learned that the students didn't know how to do the simplest things with the woodworker's tools. He was surprised because he himself had used such tools from boyhood and so took it for granted that his students could do the same. The fact that they could not, presented to his alert mind a new problem. Instead of giving up his plan for helping the young men to visualize the fundamental mechanical forms, he proceeded to teach them how to use tools. Thus it was that Professor Woodward was first led to the teaching of shopwork without any direct or immediate trade or industrial motive,⁷ though that appeared soon after.

So it came about that, in 1871, a supplementary catalog contained the following announcement:

⁷From a statement made to the author by Dr. Woodward himself.

There will be fitted up a workshop containing an elegant lathe made expressly for the University by the Fitchburg Machine Co., of Massachusetts, for turning wood and iron; a workbench and a full set of carpenter's tools. The engineering students will be able here to acquire some dexterity in the use of tools which, though slight, will be of great value to them in the subsequent work of their profession (i.e., this experience will make them better judges of workmanship). (6—10)

In carrying this plan into effect the following year, 1872, *certain tool exercise pieces were devised* as the most direct and speedy means of teaching the young men how to use tools. And these exercise pieces were, as a matter of course, based on an analysis of the process of acquiring the particular skill desired for the students. The success of the experiment must have expanded the plan rapidly for, before the end of the year 1872, another lathe, a forge, a gear cutter, and "full sets of machinist's and forging tools" were added to the shop equipment. (7—3)

The following year, in an address at Washington University, Professor Woodward revealed his developing ideas concerning shopwork in education. He saw the need of it in the common school but, as it was not then available there, it should certainly be provided in a polytechnic school. He said:

But the acquisition of this desirable manual skill requires workshops and tools and teachers; and as such essentials are not in general to be had at home or at a common school, the work must be done at a polytechnic school. Hence, at the earliest possible moment, in the lowest class, students must enter the workshop. From the bench of the carpenter, they should go to the lathe. Wood turning is an art requiring great judgment and skill, and anyone accomplished in it will testify to its great practical value. After wood comes brass, iron, and steel turning, fitting, and finishing; then the forge, where each should learn welding and tempering. This is the alphabet of tools. Next will come their legitimate use in the manufacture of patterns for castings, in the construction of model frames, trusses, bridges, and roofs; in the cutting of screws and nuts with threads of various pitch; and in the manufacture of spur and bevel wheels, with epicycloidal and involute teeth. This shopwork should extend through the entire course of four years, varying somewhat according to the professional course selected. (7—256, 257)

By 1875, Professor Woodward's general method of instruction in shopwork was as follows:

A sketch of the piece or task to be constructed is given to a class with all needed dimensions. Each student then makes a careful drawing of it to some convenient scale, with details and exact measurements.

The class then goes to the shop, is furnished with the requisite materials and tools, and each member is shown by an expert how to execute the work. Every piece must be reasonably perfect or it is rejected and a new one is required. Although the students work in the shop no more than four hours a week, the experience is valuable. It is not supposed, of course, that skilled work can be produced by this method, but it is certain that such training will make better judges of workmanship. (7—3)

70. Impressions Made by the Russian Exhibit in 1876.

From what has been said in the foregoing paragraphs about the shopwork instruction being given at the Worcester County Free Institute of Industrial Science, the Illinois Industrial University and Washington University, it is clearly evident that the thinking of several American leaders in technical education was admirably prepared to welcome the very complete presentation of the Russian system of tool instruction (cf. Chap. I) which was shown at the Centennial Exposition at Philadelphia in 1876. Dr. John D. Runkle (1822—1902), Fig. 102, president of the Massachusetts Institute of Technology, in referring to his experience at the Exposition, said:

At Philadelphia, in 1876, almost the first thing I saw was a small case containing three series of models—one of chipping and filing, one of forging, and one of machine-tool work. I saw at once that they were not parts of machines, but simply graded models for teaching the manipulations in those arts. In an instant, the problem I had been seeking to solve was clear to my mind; a plain distinction between a mechanic art and its application in some special trade became apparent. (8—332)

Dr. Runkle had become conscious of a problem similar to the one that had confronted Dr. Woodward. Dr. Runkle had observed that the few students who entered the mechanical engineering course, with a knowledge of shopwork, readily secured positions upon graduation, while the large number who had not had shop experience found it "difficult to enter upon professional work without first taking one or two years of apprenticeship." "This," he said, "always seemed to me a fault in the education, and yet I did not see the way to remedy it without building up manufacturing works in connection with the school—a step which I knew to be an inversion of a true educational method." (8—331, 332)

Dr. Runkle concluded that his first work should be to

build for the Institute a group of shops to teach the mechanic arts just as laboratories are constructed and equipped to teach physics or chemistry. He went even beyond that; he said, *“At the same time, I believed that this discipline could be made a part of general education, just as we make the sciences available for the same end through laboratory instruction.”* (8—332)



FIG. 102. JOHN D. RUNKLE

In his notable paper on “The Manual Element in Education” which appeared in the annual report of the Board of Education of Massachusetts for 1877–78, Dr. Runkle said of the Russian system:

The method is not only educational, but it constitutes the only true and philosophical key to all industrial education. If we can formulate into an educational method the arts which apply in any particular industry, we have

only to group about these art courses such other subjects of study as obviously pertain to this industry to have a scheme which shall most surely and directly fit the student both in theory and practice to enter upon its pursuit. (9—188) (Source Material, IX A)

In a paper on "Manual Education," read before the St. Louis Social Science Association, May 16, 1878, Professor C. M. Woodward said:

To Russia belongs the honor of having solved the problem of tool instruction. Others had admitted that practice in using tools and testing materials should go hand in hand with theory; but Russia first conceived and tested the idea of analyzing tool practice into its elements and teaching the elements abstractly to a class. In their hands, manual tool instruction has become a science . . .

Here is the point where the best manual-training schools differ radically from the ordinary system of apprenticeship. In the latter, the learner acquires the "arts" involved in a piece of work incidentally, and generally without a conscious analysis; in the former, the "arts" are made the direct object of his study and attention. Their subsequent combination (which may or may not follow in his school experience) is a very simple matter. (7—277, 278)

71. The School of Mechanic Arts in Boston. Immediately on his return from the Centennial Exposition, Dr. Runkle recommended to the Corporation of the Massachusetts Institute of Technology that they establish a group of "instruction shops" in which should be taught all the mechanic arts needed by young engineers. By vote of the Corporation on August 17, 1876, such a shopwork department of the Institute was established. (10—13) In this department students in mechanical engineering would receive instruction in shopwork; other professional students would be allowed to elect it; and a new secondary school would be developed, in which special prominence would be given to "manual education for those who wish to enter upon industrial pursuits rather than to become scientific engineers." (9—192) This new school was named "School of Mechanic Arts." It was open to boys who were grammar-school graduates or to such as could pass examinations in arithmetic, geography, and English composition and who were not less than fifteen years of age. The tuition was \$150.00 a year, including materials used for the regular exercise pieces in shopwork. (1—IV, 24)

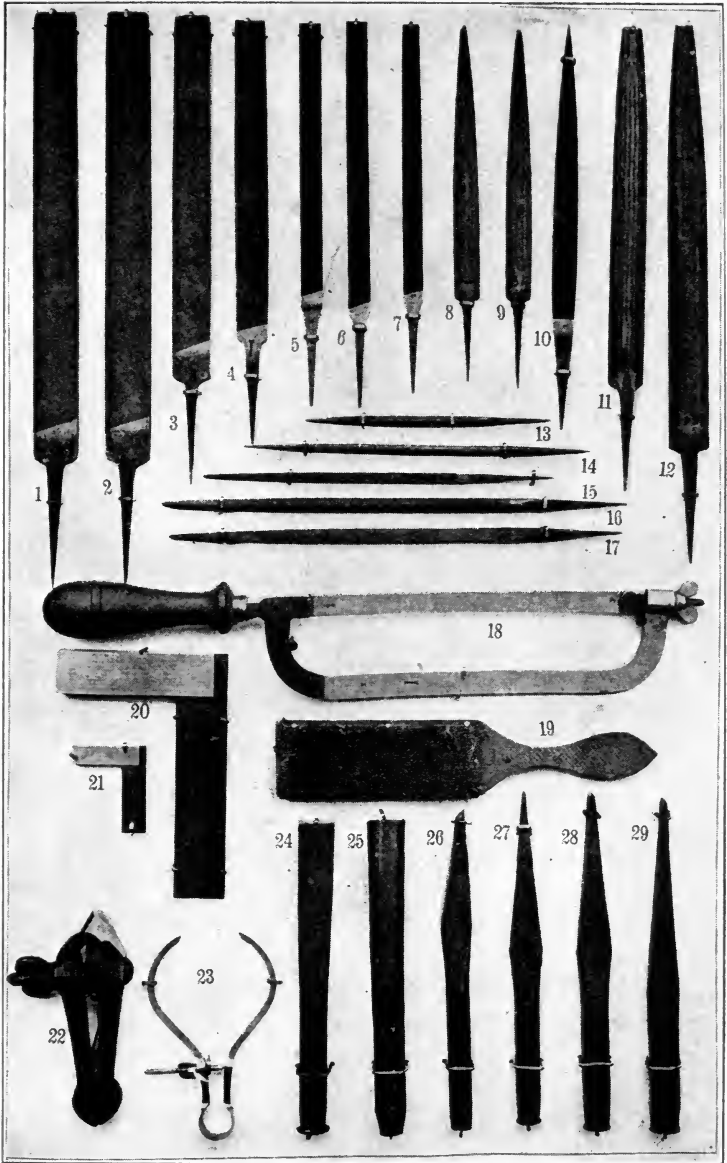

FIG. 103. TOOLS FOR COURSE IN "VISE WORK," SCHOOL OF MECHANIC ARTS, BOSTON

Besides shopwork, the course of instruction, which was to cover two years, was to include arithmetic, algebra, geometry, English, physics, and drawing. At first, twelve hours a week—three lessons of four hours each—were devoted to shopwork, and the remainder of the time to drawing and the other studies. Later three-hour lessons in shopwork were considered better than four-hour, so the total shopwork time was reduced to nine hours a week.

The shopwork included: 1. In wood—(a) carpentry and joinery, (b) patternmaking. 2. In iron—(a) vise work, (b) forging, (c) foundry work, (d) machine-tool work.

COURSE IN VISE WORK

The first of these courses to be worked out was that in vise work. It was, therefore, the first American course developed on the Russian plan. This was worked out by Valentine Wallburg, the shop teacher, under the supervision of Professor Channing Whitaker. The shop for this course contained "four heavy benches, each eighteen feet long, three feet wide, and two and one-half feet high. To each bench, eight vises were attached. It was supposed that one teacher could instruct thirty-two students at a time, and this has been found to be about the right number. At the beginning of the course, it is quite enough; but later, when students have acquired some skill and independence, this number can be successfully taught." (9—196) (In the report published four years later, it is stated that "The shops are arranged for teaching sixteen in a section, except that for forging, which contains only eight forges, on account of the smallness of the room.") "At each vise there are four drawers, each large enough to hold all the tools needed by the student at any one time; so that four sections of thirty-two each can take the course simultaneously." (9—196)

The tools used in the course are shown in Fig. 103. It will be noticed that files and chisels predominate. Probably a good hammer was included, though not shown. The first fifteen in the course of exercises are shown in Fig. 104. The course was divided as follows:

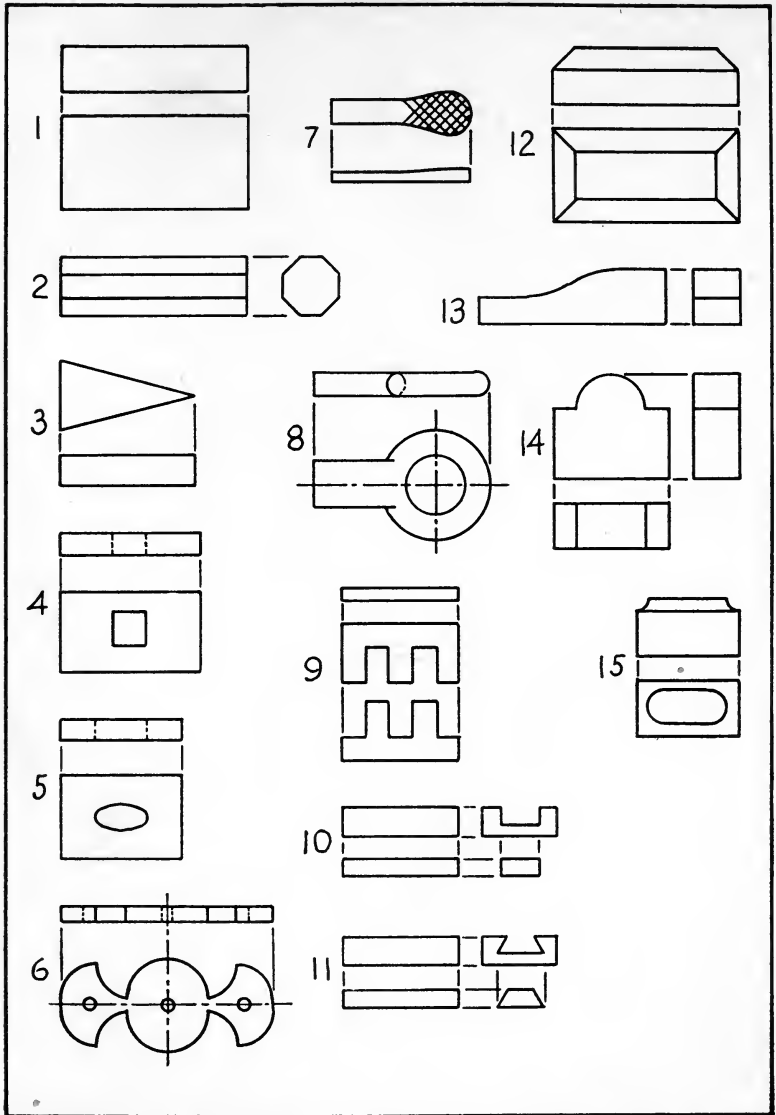

FIG. 104. COURSE IN "VISE WORK"—COLD METALWORK

1. Filing to line—all cast iron. (First five exercises)
2. Template work—sawing and filing. (Exercise 6)
3. Freehand filing—bench vise—cast iron. (Exercises 7 and 8)
4. Fitting—cast iron and steel. (Exercises 9, 10, 11)
5. Chipping—cast and wrought iron. (Exercises 12, 13, 14, 15)
6. Chipping and sawing—cast and wrought iron. (Exercises 16, 17)
7. Chipping—half-round chisel and spline work. (Exercise 18)
8. Freehand filing with hand vise—steel wire. (Exercises 19, 20, 21, 22) (9—197)

The stock was given to the student cut to approximately the correct size so that only a small amount of material was required to be removed by the student. For example, the block of metal in Exercise 4 was given to the student with a $\frac{3}{4}$ " round hole drilled in it. He was to make the hole square without increasing its diameter. The block of cast iron in Exercise 12 was given in the form of a rectangular prism $1\frac{1}{4}$ " x 2" x 4", planed on all sides. The work of the student was to make an accurate chamfer around the top of the block.

The second course in vise work included:

1. Scraping. Three test-surfaces made from blanks of Piece No. 1 in the filing course.
2. Breast drilling. Pieces of cast iron, of wrought iron, and of steel, to learn to drill from flat surfaces, and from sharp edges and corners, at different angles, and with different-sized drills.
3. Tapping. Tapping the holes drilled in 2 with both right and left-hand taps.
4. Reaming. Reaming holes drilled in 2, to perfectly fit true gauges of different sizes.
5. Thread cutting with dies and jam plates. Examples in steam, gas, and water piping and fitting.
6. Soldering. Tin, iron, iron and brass, iron and steel, plumbers' joints.
7. Brazing. Iron, iron and steel, brass, brazing with silver solder.
8. Burnishing.
9. Stoning.
10. Bluing. (9—212)

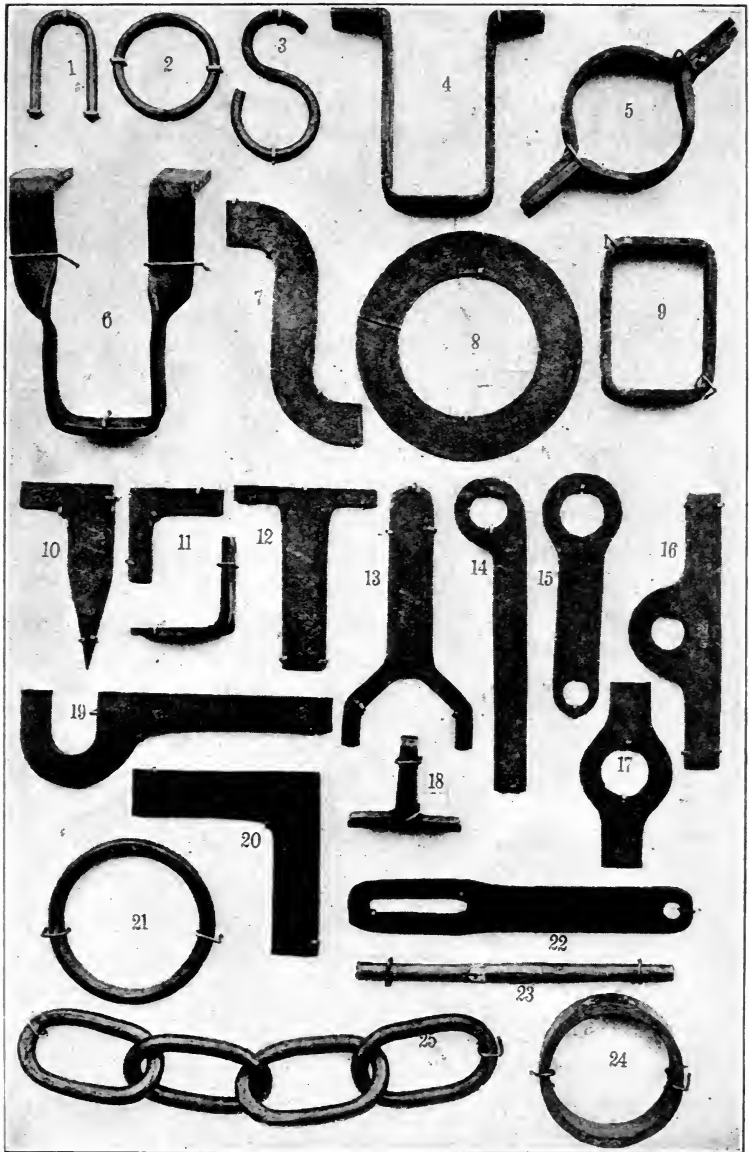

FIG. 105. BEGINNING EXERCISES IN COURSE IN FORGING, SCHOOL OF MECHANIC ARTS, BOSTON

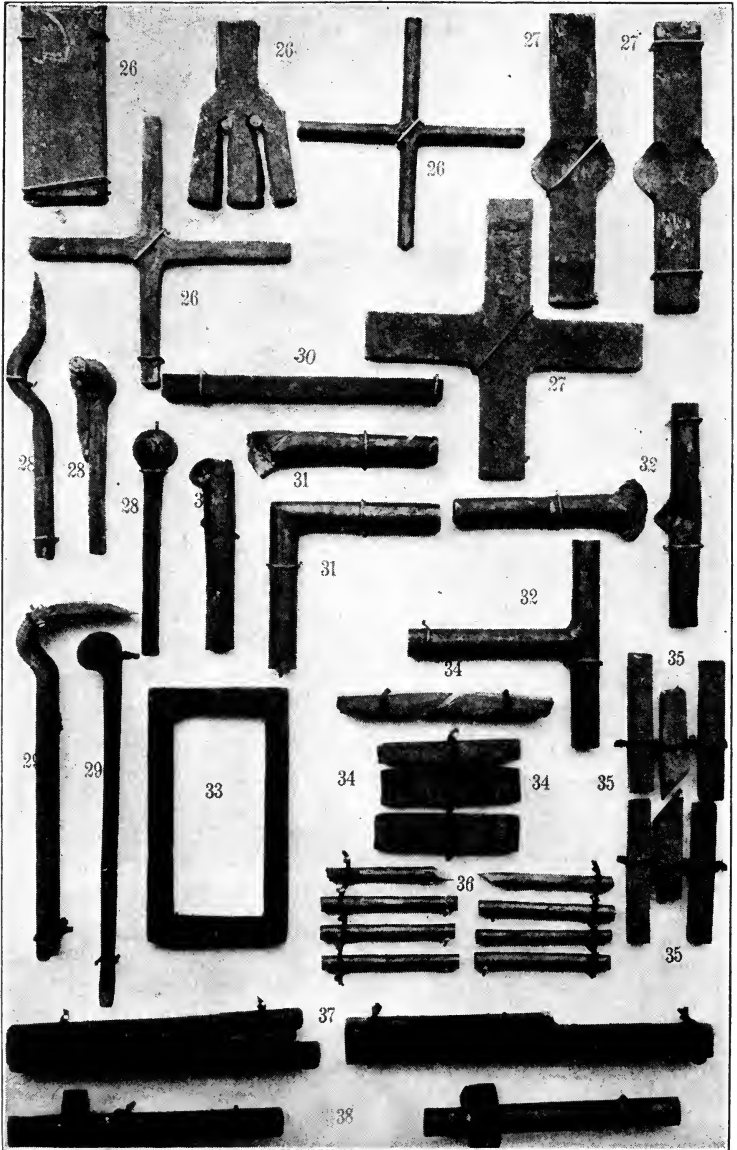

FIG. 106. WELDING EXERCISES, COURSE IN FORGING, SCHOOL OF MECHANIC ARTS, BOSTON

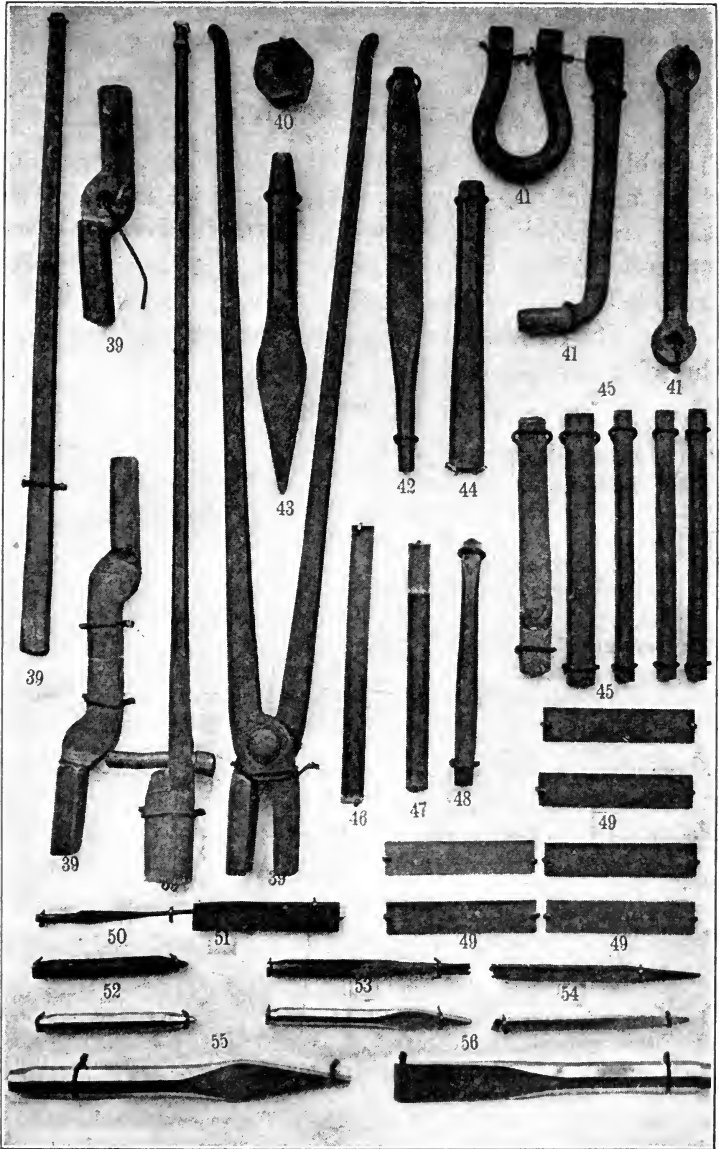

FIG. 107. TOOLMAKING EXERCISES, COURSE IN FORGING, SCHOOL OF MECHANIC ARTS, BOSTON.

It was stated that the soldering, brazing, and bluing were classed as vise-work to save multiplying courses.

COURSE IN FORGING

Probably the fundamental ideas of these new courses growing out of the Russian system of tool instruction are best illustrated in the course in forging worked out by Thomas Foley and Charles T. Main under the direction of Professor Channing Whitaker. This course is shown in Figs. 105, 106, and 107. The numbers in the illustrations correspond to those in the following list:

- Nos. 1-9. Bending.
- 10, 11. Bending and drawing.
- 12, 13. Bending and splitting.
- 14-18, 22. Punching and forming.
- 20. Welding.
- 21. Bending and welding, Ring of round iron.
- 23. Welding angle from flat bar. Weld at angle.
- 24. Bending and welding. Ring of flat iron.
- 25. Bending and welding.
- 26. Punching, splitting, bending, and drawing.
- 27. Welding cross of flat iron. Weld at intersection.
- 28. Bending, drawing, punching, and welding. Hinge hook.
- 29. " " " " Hinge eye.
- 30. Drawing. Key tapering $\frac{1}{16}$ inch in 6 inches.
- 31. Welding angle from round bar. Weld at angle.
- 32. Welding T from flat bar. Weld at intersection.
- 33. Upsetting, bending, and welding.
- 34-36. Scarf welds.
- 37. Faggot weld.
- 38. Collar welded to scarf.
- 39. Upsetting, drawing, bending, welding, punching, and riveting.
- 40. Punching, drawing, and upsetting.
- 41. Upsetting, punching, and bending.
- 42. Steel. Drawing and tempering. Punch, from old file. Color, blue.
- 43, 44. Steel. Drawing and tempering cold chisels. Color, deep blue.
- 45. Steel. Welding steel to steel and steel to iron.
- 46. Steel-spring drawing and tempering. Temperature indicated by oil.
- 47. Steel-spring drawing and tempering. Temperature indicated by soft pine.
- 48. Steel drill (large). Drawing, filing, and tempering. Water temper. Color, purple blue.
- 49. Steel. Straight edges. Upsetting and filing. Made straight without a standard.

50. Steel drill (small). Drawing, filing, and tempering. Color, straw color at point; faint blue at stem.

51. Steel matching tool. Drawing, filing, and tempering. Oil temper. Color, dark straw.

52. Steel center punch. Drawing, filing, and tempering. Water temper. Color, purple blue.

53. Steel cape chisel (small). Drawing, filing, and tempering. Water temper. Color, purple blue.

54. Steel diamond-pointed hand tool. Drawing, filing, and tempering. Water temper. Color, straw.

55. Steel cape chisel (large). Drawing, filing, and tempering. Water temper. Color, deep blue.

56. Steel flat chisel (large). Drawing, filing, and tempering. Water temper. Color, deep blue. (9—212—214)

It will be observed that each item in this list is intended to teach a fundamental process in the art of forging; yet some of them, in Fig. 107, are not "abstract exercises" but are useful articles—tools. Following this course, students were expected to make more complex practical applications of the fundamental processes learned in the pursuit of this course. In the Institute catalog for 1885—86 is this statement concerning the character of the shopwork courses:

The handwork is done without regard to pecuniary profit, but is designed to give the student good judgment, self-reliance and executive power, pieces practically useful being introduced when it can be done without detriment to the systematic arrangement of the courses. (1—IV, 25)

The often-quoted general analysis of the forger's art, which served as a starting point in the working out of this course, is as follows:

First. The management of the fire and degrees of heat.

Second. Bending, without changing the cross-section.

Third. Drawing down or reducing the cross-section.

Fourth. Jumping, or upsetting; that is, shortening the piece and increasing its cross-section.

Fifth. Building up or welding.

Sixth. Hardening and tempering. (9—213)

In the statement concerning this course attention is called to the fact that as the principal aim of the course is the acquiring of manual skill in the art, only such tools are furnished the students as are necessary to this end; none of the appliances and machines are provided which are used

simply to facilitate the work. Speed in material production is not a consideration; the whole effort is on learning the art as thoroughly and quickly as possible. The report states,

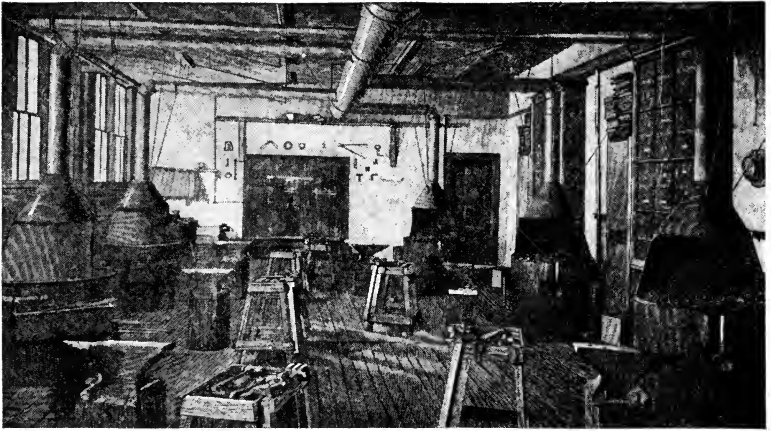

FIG. 108. FORGE SHOP, SCHOOL OF MECHANIC ARTS, BOSTON

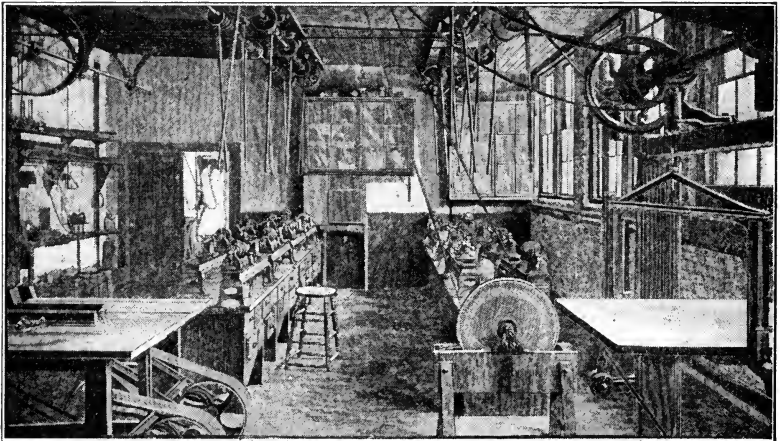

FIG. 109. WOOD-TURNING SHOP, SCHOOL OF MECHANIC ARTS

“Experience has already taught us that the shorter and more distinct the steps are, the more rapid will be the student’s progress.”

The shop in which this early course in forging was taught is shown in Fig. 108.

Beginning Oct. 1, 1878, the School of Mechanic Arts was in charge of a committee of the Institute faculty, of which Professor John M. Ordway was chairman.

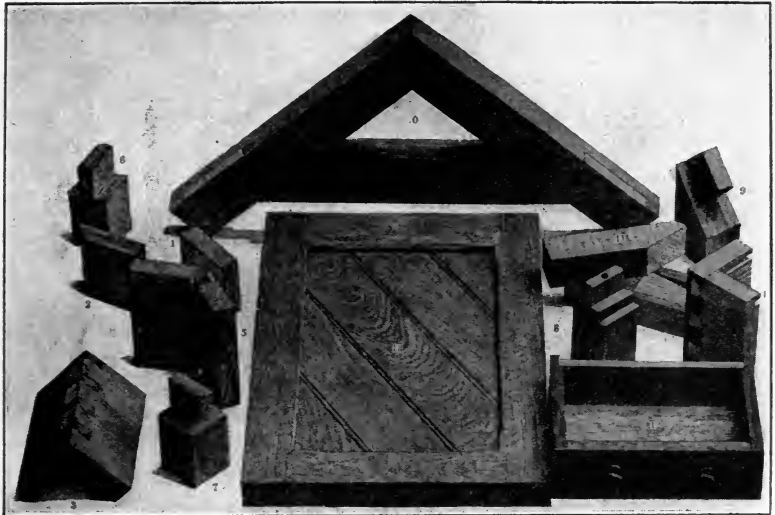

FIG. 110. COURSE IN CARPENTRY AND JOINERY, SCHOOL OF MECHANIC ARTS

COURSE IN WOODWORKING

Included in the woodworking courses were the elements of carpentry, joinery, wood turning, and patternmaking. The woodworking shop was 50 ft. by 20 ft. At one end were benches and at the other turning lathes on cases of drawers. Fig. 109. Between these were the power saws for cutting lumber to the dimensions needed for the exercise pieces. The first exercises were in the use of the saw and plane; then followed the series of joints shown in Fig. 110. These were:

- | | |
|----------------------------|------------------------------|
| No. 1. Square (butt) joint | 8. Tusk tenon |
| 2. Miter joint | 9. Brace tenon |
| 3. Dovetail joint | 10. Rafters with collar beam |
| 4. Blind dovetail joint | 11. Truss tenon |
| 5. Miter dovetail joint | 12. Drawer |
| 6. Common tenon | 13. Panel |
| 7. Keyed tenon | |

In addition to these, each student was required to make a frame combining several of these joints. The course in wood turning and patternmaking is shown in Fig. 111. The woodworking instructors were George Smith and Z. Nason.

Courses in foundry work and machine-tool work were also

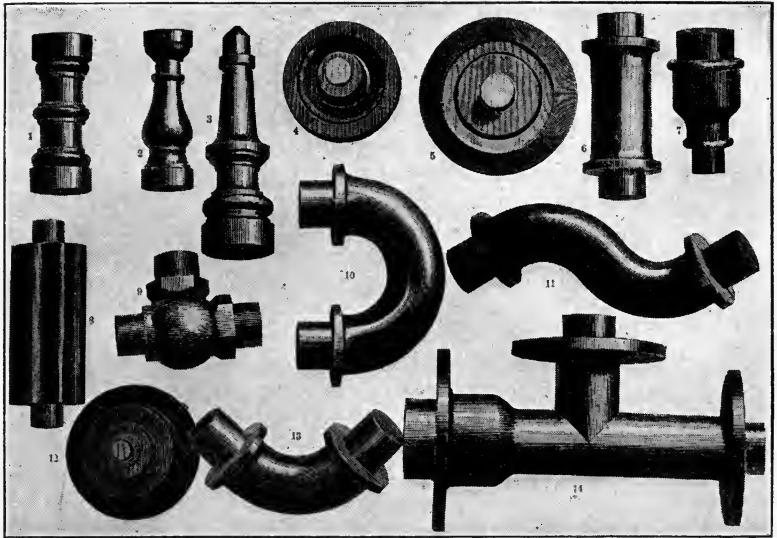

FIG. 111. COURSE IN WOOD TURNING AND PATTERN MAKING, SCHOOL OF MECHANIC ARTS

developed at the School of Mechanic Arts during this early period, but the analyses upon which they were based were not as complete at that early time as for those already outlined.

72. Educational Value of Instruction in the Mechanic Arts. The report by Dr. Runkle, already referred to, (Source Material IX A) reveals the fact that he recognized the value of instruction in the mechanic arts for the purposes of general education. He even went so far as to recommend a special mechanic-arts high school for a large city, a group of shops for a town high school, and a woodworking shop for a district school. He then discussed costs. He ended his report with the following:

This system of mechanic-art teaching is earnestly commended to all, with the assurance, that, in the hands of competent and faithful teachers, it will prove entirely successful, not only on educational, but also on economical grounds. (9—218)

This was in January, 1878. Four years later, in January, 1882, Professor John M. Ordway, then vice-president of the Massachusetts Institute of Technology, wrote the following letter to the secretary of the Public Education Association of Philadelphia, which gives in very specific terms his estimate of the value of the mechanic-arts instruction, especially as carried on at the School of Mechanic Arts in Boston:

The instruction in carpentry is of direct use to those who have to work in wood, because the woodworking tools—the saw, the plane, the chisel, the drawknife, the hammer, the auger, the square, the rule, and the line—are used in many trades. One who has had this practice may become a house carpenter, a ship carpenter, a cabinetmaker, a wheelwright, a carriage builder, or a millwright.

The wood turning and patternmaking extend the range of these very important branches.

Though we do not at present include wood carving in our course, we may say that one who has gone through with carpentry and wood turning, having had at the same time instruction in drawing, is well prepared to learn the art of carving.

The foundry work which the students do, gives them a good beginning in the business of the iron, brass, and bell founders.

Blacksmithing is essential for the boiler maker, the nail and bolt maker, the chain maker, the cutter, and the iron bridge builder.

The vise work is important for locksmiths, gunsmiths, and watchmakers and, of course, for the general machinist.

The engine lathe work is that of machinists, and is a good preparation for taking care of any kind of machinery.

We ought to have a paint shop and a department of soldering and brazing, but we are at present short of room. I hope we may sometime get more land and add these things.

Our course makes no provision for the textile manufacturers, for the work of the saddler, the printer, the bookbinder, the engraver, the brick layer, the plasterer, the tanner, the currier, the glass blower, or the chemical trades. But the general training of the hand and the eye gives a dexterity and accuracy which lies at the foundation of all good and profitable work.

In all the arts the hands must be used as well as the brain, and the handling of tools gives a more practical control of the muscles than gymnasium exercises, or no exercises at all.

Nature indicates the use of tools to the growing boy, who must have at least his jackknife. It is important that right habits be formed, and that the boy should use his muscles to some purpose instead of working at ran-

dom. Training in the accurate use of tools affords a good mental discipline aside from its everyday, practical use. (1—II, 998, 999)

Professor Ordway stated, further, that a graduate of the School of Mechanic Arts, "after two years of work in practice and related studies under this method, with one year of experience in the trade which he may select, is better qualified than by an actual apprenticeship of five years, with the immense additional gain of studies and drawing which have accompanied his course in practice, and the broad and varied character of his training which render him independent of the precarious demands of any one trade." (1—II, 999)

From the foregoing, it is evident that Dr. Runkle and his associates, through their experiences in the School of Mechanic Arts, had become convinced that a course of intensive training on the Russian plan should precede apprenticeship or employment in a productive shop. This was far more economical educationally than to begin by working in a shop organized on a productive basis.

They believed that such training in the mechanic arts should be made available to boys in the public schools—certainly for those who were fourteen years of age or older, and perhaps for those who were only twelve.

They did not indicate how comprehensive such a course for boys in public schools should be, but Professor Ordway, at least, seemed to have in mind an indefinite picture of some kind of general shop training that would be broader in scope than the course that had been given under his supervision.

73. Professor Woodward's Vision of a Manual-Training School. On the first day of October, 1877, Professor C. M. Woodward, dean of the Polytechnic School, Washington University, issued a statement to University officials which was at once a report of discovery, a vision of a new realm in education, and a prophecy which was to come true within his own lifetime. His discovery was the result of his study of the Russian system of tool instruction. In his official statement, he said:

All complex mechanical processes result from different combinations of a few simple elements, just as all the words of the dictionary are but combinations of the letters of the alphabet. The true method of instruction is to teach the elements first, i. e., "analyze the processes requiring manual skill and teach each process by itself to a class." The first principles are taught and illustrated by practical examples, just as we would teach algebra or music. This alphabet of steps in mechanical science is much simpler than would at first be supposed.

The process of instruction must precede that of construction; that is, the student must learn the use of tools before he is required to construct anything. Here is the point where the best manual-training schools differ radically from the ordinary system of apprenticeship. In the latter, the learner acquires the "arts" involved in a piece of work incidentally, and generally without a conscious analysis; in the former, the "arts" are made the direct object of his study and attention; their subsequent combination (which may or may not follow in his school experience) is a very simple matter.

The immense advantage of this method would seem to be obvious. In the first place, the shop is not embarrassed by commercial issues. Pecuniary considerations do not come in to confine students to that which they have already learned to do well, and which, on that account, they ought to lay aside. And secondly, the scope of the shop which manufactures for the market is generally very limited, and the apprentice is apt to come out entirely ignorant of the use of some of the rarest and most interesting tools and processes. (12— —)

So much for the discovery. Professor Woodward's vision was of shopwork being placed on the same educational plane with other school subjects. He saw the mechanic arts analyzed, pedagogically organized, and taught under the guidance of the same principles that have influenced methods of teaching the sciences, mathematics, and even the languages. The mechanic arts so taught were not to teach trades. (Thus he avoided the current fear in teaching shopwork in schools.) The products were to have no market value; therefore the shop must be supported in the same way as science laboratories. Four to eight hours of instruction a week for each shop class in high schools and three to four hours in grammar schools would be sufficient to give boys the needed instruction in the "universal tools." Such instruction would prevent many young men from drifting into "overcrowded and uncongenial occupations, or lapse into idleness or vice." (12— —)

His vision was in itself prophetic, but he goes on to sug-

gest that possibly "the best of us have failed to realize what is included in the term 'education.'" "In our desire to eliminate all narrow utilitarian motives, have we not sometimes run to the other extreme and excluded from our schools important and essential branches of study because they were suspected of being useful?" Later in the address, he said, concerning the University:

A few years hence may find us in full possession and use of a set of instruction shops equipped with all the various kinds of important tools of the best workmanship, including a prime motor like a twenty-five horsepower Corliss engine; and these shops, it may be, will be open to the youth of St. Louis at a merely nominal cost. . . . I shall not now, however, give my plan for such an establishment. I wish only to point out methods by which at once some of our preparatory students may be allowed the benefit of some instruction in shopwork. (12—)

That same year, 1877, having outgrown the shop of 1872, and under the impulse of the new vision, Professor Woodward secured the use of an old dormitory building, known as the "Philibert Mansion," and transformed its interior into a group of instruction shops.

The basement he fitted up for a blacksmith shop with one "portable forge, supplied with a hand blower" and "all essential tools for forge work."

On the first floor was a machine shop, 15 ft. by 36 ft., equipped with workbenches, iron vises, and tools for twelve students. There was also in the room an engine lathe, a speed lathe with slide rest, a lathe "with circular-saw attachments," a light wood lathe, a "velocipede scroll saw," a planer, "capable of dressing a piece seven inches square and nineteen inches long," a gear cutter, and "a fair set of machinists' tools."

On the second floor was a woodworking shop equipped with workbenches, drawers, and tools for twenty students. Each student was provided with "about four feet of bench room, a vise, a cupboard, a tool drawer, containing three planes, two chisels, a saw, a square, a hatchet, a gauge, and some special wood-carving tools." Tools less frequently used were kept in a "general drawer." There was also an office

for the instructor, two closets for the finished work and a storeroom for lumber." (12—)

In May, 1878, Dr. Woodward said:

The amount of time given to shopwork has generally been only four hours per week—two lessons of two hours each. The junior class in mechanical engineering gave eight hours. Shopwork has been done in the afternoon, and there has been no less work required in the morning recitations than formerly. Though four hours per week—which is equivalent to two days per month—seem too small an allowance to be of much practical value, four years, on the present plan, would suffice to give an excellent idea of the uses of all our tools, the properties of materials, and considerable manual skill. I have yet to hear from the parent who does not approve of our plan of shopwork. Our running expenses in the shop are now about \$100 per month; but we could, without perceptible increase of cost, double our present number of students. No extra fee has been charged on account of shopwork; but, without permanent endowment, this arrangement cannot long continue. The experience of this year has been invaluable to us, and we are now clear in our conviction that a series of commodious instruction shops, well furnished with machinery and tools, and so liberally endowed as to require only a nominal fee from students, would be of inestimable value to the youth of this city. (13—I, 884)

In this chapter, an effort has been made to set forth the condition of school shopwork in the United States before and just after the coming of the Russian influence in 1876. By describing in considerable detail the aims, equipment, organization, and methods of teaching in a few outstanding institutions, the way has been prepared for an understanding of the remarkable development which took place in the manual training during the years from 1880 to 1900, giving to educational handwork what may be considered a permanent place in public education.

SOURCE MATERIAL IX, A

THE MANUAL ELEMENT IN EDUCATION

By John D. Runkle

From Forty-first Annual Report of the Board of Education,
State of Massachusetts, 1876-77

There is a growing interest in this subject. The question is, whether we can introduce the manual element into our system of public instruction, in order that a larger number of those whose education, as pupils, ends in the public schools, shall be led more directly than is now the case to some specific pursuit. In this direction, it seems to me, we are to look for the means to elevate and dignify the labor of our country. We must educate, and at the same time make skillful, the laborer. In this way only shall we ever solve this vital problem of the relation between labor and capital, and, at the same time, most effectively develop our great and growing industries.

I wish, first, to offer a few introductory thoughts; secondly, to consider the method to be followed in teaching the manual element, with such proofs as are at hand of its educational value and efficiency; and lastly, to say something of the way to introduce this element into our system of public instruction.

In the early days of the Republic, when our system of public education was still in its infancy, mental and manual education were much more intimately connected than at the present day. The industries of the country were still in a crude state; agriculture and a few only of the more necessary mechanic trades having any existence. These trades demanded but little artistic taste, and not the highest manual skill. But the educational needs of the time were quite well met in the apprenticeship system, which existed then in its best form. The master became responsible, in an important sense, for the mental and moral well-being of the apprentice, besides teaching him the manual of his trade, with such knowledge of the theory, and such experience, as he was able to impart. By his attendance, for three or four months of each year during his apprenticeship, upon the district school, the mental culture of the apprentice was not entirely discontinued; and thus, by alternating between the school and the shop, his mental and manual education were never entirely divorced, but each in an important sense aided the other. During this formative period of the student's life, one set of habits was not formed to the exclusion of others, which in the end might prove more important.

As time passed, a more marked separation between mental and manual education began to take place. The schools gradually improved. Better methods of teaching and a larger number of subjects were introduced, and a higher standard set, all demanding more time from the pupil. But quite as marked a change was going on in the industries. Increased demand led to competition, to the invention of special tools to cheapen production, to a greater subdivision of labor, and to the concentration of the individual upon a very narrow range of work. Thus the apprenticeship system for learning a trade in its old and best form has passed away, never to return.

As it exists today it is an advantage to neither party. The apprentice can only learn a narrow specialty, so narrow, as a rule, that its only value to him is the meager pittance which he can earn from day to day, but at the sacrifice of any further educational advantages; while the master finds it for his interest to pay for the skill he needs, rather than put into his carefully adjusted chain of operations a weak and nearly useless link. In this way, the school and the shop have become so widely separated, that they are no longer mutual helps, as in past times, in developing the highest capacity or the highest manhood. The student who enters the shop at fifteen for a three or four year's apprenticeship seldom returns to the school; and, on the other hand, the student who completes his high-school course at eighteen seldom willingly enters the shop as an apprentice, with the intention of becoming a skilled mechanic, and earning a livelihood by manual labor. His twelve or fourteen years of mental school work, whether highly successful or not, have, through habit, if in no other way, unfitted him for all manual work, even if he has not in many ways been taught to despise such labor. Thus it happens, that today educators, lawmakers, philanthropists, and all interested in the highest good of the largest number of the people, or in the best development of our growing and varied industries, are looking for the remedy through education, not of the head alone, but of the head and hand combined in the same system, in order that the education may lead each pupil to some definite end, or directly to the threshold of some special pursuit; that the student's skill of head and hand combined shall have some small commercial value when he has completed his prescribed course of study.

There is a growing feeling that our public education should touch practical life in a larger number of points; that it should better fit all for that sphere in life in which they are destined to find their highest happiness and well-being. It is not meant by this that our education should be lowered mentally, but that it should be based, if possible, upon those elements which may serve the double purpose of a mental culture and discipline—a development of the capacity of the individual with and through the acquisition of artistic taste and manual skill in the graphic and mechanic arts which most largely apply in our industries. It is true that our system of public education aims to prepare those who wish it for further literary and professional study; but, for the large proportion of pupils, the grammar and high schools are finishing schools; and it would seem not only proper, but just, that they should be adapted to the wants of the largest number. If this is to be done through the introduction of a larger manual element, a few questions at once arise.

1. On what ground can we justify the introduction of the manual element into our system of public education?

Solely on the broad ground of its educational value to all. It is only on this ground that we can justify the introduction of drawing, either freehand or mechanical, into our public schools. It is plain, that if all were taught drawing, not more than one in a hundred, if so many, would ever practice the art as a livelihood; while the ninety and nine would be compelled to pursue a study of no value to them, if it cannot be so taught as to be justified on purely educational grounds. The advocates for the introduction of drawing must then show that the subject is either intrinsically educational or

can be made so by the method of teaching it, of which it seems to me there can be no doubt. Today, in all the best technical schools, both at home and abroad, the art of drawing is required of all, whether the pupil's chosen course demands its special application or not. It is, besides, slowly gaining a place in our public schools; but the product must be something more than a little manual skill to justify it. The manual element, either in the graphic or mechanic arts, must be taught by such methods as will cultivate the other powers through the acquisition of manual skill.

2. Have we found a method of teaching the mechanic arts, both theoretically and practically, similar to those used in teaching the sciences and other purely mental subjects? To answer the question as best I can is the main purpose of this paper. Before asking attention to any special shop courses, and to the educational method which they exhibit, it will be well to briefly point out what is meant by the Russian method of instruction in the mechanic arts, and in what way it differs from the trade schools which have existed for so many years, especially in France and Germany. It is not meant that Russia was the first to introduce the manual element in education, as some have supposed. The Imperial Technical School of Moscow was the first to show that it is best to teach an art before attempting to apply it; that the mechanic arts can be taught to classes through a graded series of examples by the usual laboratory methods which we employ in teaching the sciences. After these arts have been learned, both theoretically and practically, the student is sent into the construction shops to apply his art knowledge. Making the art and not the trade fundamental, and then teaching the art by purely educational methods, is the Russian system. The system is instruction in the arts for the purpose of instruction, and not construction for the purpose of instruction. The method is not only educational, but it constitutes the only true and philosophical key to all industrial education. If we can formulate into an educational method the arts which apply in any particular industry, we have only to group about these art courses such other subjects of study as obviously pertain to this industry, to have a scheme which shall most surely and directly fit the student, both in theory and practice, to enter upon its pursuit.

It may be well to further illustrate this fundamental idea by a somewhat different line of thought; as, to many who have not had their attention called to the subject, the distinction between an art and a trade may not be at once apparent.

"Everyone is well aware that the successful study of any art, as freehand and linear drawing, or music, instrumental or vocal, or painting, is only attainable when the first steps are strictly subject to the laws of gradation and succession; when the student adheres to a definite method, thus surmounting, little by little, and by certain degrees, the difficulties to be encountered. All the arts just named possess a method of study long constituted a part of the education of the well-instructed classes. They have therefore become subject to scientific analysis and objects of investigation, with the view of defining those conditions which should render the study of them as easy and well regulated as possible."

Let us see, now, how these thoughts apply to the mechanic arts, and, for

definiteness, let us fix our minds upon those arts which apply to wood and the metals.

In all constructions, a certain limited number of typical forms are found, these forms being more or less modified, to adapt them to special cases. These forms will also fall into groups, each to be worked out in a certain way, and with special tools. If, then, the student can be taught to work out these forms, each in the best way, and with the tools best adapted to the work, he will be far advanced in the skill which will make him available and useful in construction. The ideas involved in the system are, first, to entirely separate the *art* from the *trade*, the *instruction* shops from the *construction* shops; secondly, to do each kind of work in its own shop; thirdly, to equip each shop with as many places and sets of tools, and thus accommodate as many pupils, as a teacher can instruct at the same time; and fourthly, to graduate the samples to be made in each shop according to some scale, that of difficulty being probably the best in practice.

It will be seen, then, that the problem thus far is simply one of systematic instruction, given by an expert in each shop, and having the same end in view as instruction in any other subject or department. The aim is to give sufficient skill in each specialty in the shortest possible time, and to give the instruction to as many at the same time as the teacher can well instruct, thus securing the greatest economy of time and, therefore, money to both teacher and pupil.

The solution of the problem has been approached from the instruction side, and not from the construction side, and in this consists its fundamental and thoroughly practical character, as part of a system of education. The system presupposes the student's ignorance, and begins at the foundation, both in theory and practice. Every step well taken from such a beginning is a clear gain, and the successive steps have only to be taken to arrive at the goal of success.

Another value of the system is, that it is equally well adapted to the wants of each class, or grade, of students. If one wishes to be a mechanical engineer, and finds that he has the ability to master the highest theoretical questions involved, the amount of shopwork will be graded to meet his needs; if, on the other hand, the student looks forward to the rank of a first-class machinist, he will need more mechanical dexterity, and will therefore work out a larger number of examples and be required to do less in the higher mathematical and theoretical studies.

It is also an exceedingly important feature of this system, that the instruction shops are the least expensive to equip and maintain; and, further, it is not necessary for the highest success of this instruction, that construction shops should also be immediately connected with the school, either as at St. Petersburg or at Moscow. In this country, the young engineer, or machinist, after graduating in such a course, will find no difficulty in completing his practical education in great manufacturing works, and probably under circumstances quite agreeable to those who have already spent all they could borrow to complete their chosen course of study. Further, the system applies equally to all industrial arts needing manual skill.

In each case, the details must be worked out simply as an educational problem, and the instruction put in charge of an expert specialist, who

understands theoretically and practically the particular manipulation. With the same skill, energy, and perseverance as are needed to command success in the teaching of any subject, we shall not fail of corresponding success in the teaching of practical industrial art. With the ability to make will come the desire to create, to those who have the capacity to rise into the higher realms of their chosen art.

(At this point Dr. Runkle describes the equipment and the course of instruction in the School of Mechanic Arts, connected with the Massachusetts Institute of Technology, and quotes at length from the Report of the Industrial School in Boston.)

Let us now spend a few minutes upon the third point with which we set out; namely, is it feasible to introduce to any extent this manual element into our system of public instruction?

Suppose that we admit for the moment the educational value of the system to justify its introduction; and, further, suppose that a few special mechanic-art schools could soon begin to furnish teachers; then how could we proceed with the least disturbance to our system as it now exists?

The first question is, At what age have pupils sufficient physical development to enter upon any of these shop courses? We have found beyond question that brains as well as muscle are needed to attain rapidly to the highest success in manual skill; but it is also certain that more elementary courses could be designed, and the time of each lesson so shortened, that a well-developed boy of twelve could make fair progress. But it would take him longer to acquire the same skill than it would after greater physical and mental development. I have no reason to doubt of success, if boys should be put upon the wood courses at twelve; but I should prefer fourteen, the earlier years having been devoted to the graphic arts, including the typographic.

There are three educational centers which we will consider separately: First, the city; secondly, the town, with its high school so situated as to accommodate all parts of it; and thirdly, the district school. For the city, two courses could be followed; first, to establish a mechanic-arts school, with a three years' course of mental and manual study judiciously combined, and open to graduates of the grammar schools upon examination; or to establish a series of art shops in a central part of the city, and combine the instruction in them with the mental after a given age. These shops could also be open evenings for the purpose of the manual education of large numbers who could by no possibility have any other opportunity.

In the town, the shops could well be made a part of the high school; or, if independent of any particular school, they could be used for such pupils, and in such connection with all the schools, as the authorities might decide.

In the district, a single room fitted up to teach the use of the saw, plane, chisel, and auger, the common woodworking tools, or what seemed best adapted to the locality, would be all that need be done.

The question is often asked, Why not make salable articles, and thus meet wholly or in part the cost of the instruction and of the materials used? We should be obliged to make what would sell, which would at once break up any systematic and progressive series of lessons for developing skill in any special art; and, besides, when the student has once learned how to

make an article fit for sale, it is not for his interest as a learner to make the same piece a second time. He needs a lesson of a little higher grade of difficulty—one in which some modification of a manipulation already learned, or a new manipulation, is introduced. When the student has become familiar with the use of the tools in the few fundamental arts, and through the acquisition of such use has also worked out the elementary processes and combined them into the ordinary typical forms to be found in practice, then he will be able to apply his knowledge in production; and the simple question is whether he shall at once apply this knowledge in manufacturing outside of the school at its market value, or whether the city or state should establish trade schools, or manufacturing establishments, not only to teach the art elements, but also to furnish an opportunity for their application in manufacture.

All experience has proved that, to educate the individual or the race, we must expend money, not make it; and all attempts to evade this law have proved failures, and will to the end. All successful manufacturing not only demands, but is based on a knowledge of the arts and sciences which apply. The most artistic design, and the most careful and scientific selection and proportioning of the materials, will be of no avail if the manual skill be wanting; and this skill must be acquired through some system of teaching, or picked up without any system in the manufacturing shops. A series of art shops, or laboratories, equipped simply for teaching, can be provided for a comparatively small sum of money, and can be carried on, considering the teaching capacity, at a small expense.

Suppose, for instance, that we should confine ourselves in wood to—I. Carpentry and joinery; II. Wood turning; III. Patternmaking; in iron, to I. Vise work; II. Forging; III. Foundry work; IV. Machine-tool work. It will be best to have but one room for wood, but so arranged that classes in I and II can be taught at the same time. In patternmaking only one section can be taught at a time, as each student will have to use both bench and lathe. If all the shops are arranged to teach sections of sixteen, it will be seen that ninety-six students can be taught at a time; and if each student gets but three shop lessons per week, of four hours each, the teaching capacity of these shops will be three hundred and eight-four students. If the length of each lesson be two hours instead of four—and lessons shorter than two hours would not be desirable—the teaching capacity of the shops would be doubled. If sixty two-hour lessons should be given in each of the six courses, we could in three years, of forty weeks each, carry seven hundred and sixty-eight students over the ground. If the series of samples to be used in each shop are made as part of the instruction in other shops, thus reducing the expense to first cost of materials, the cost per student for materials will not exceed ten dollars per year. Each shop will need an expert teacher at a salary, say, of \$1,000 per annum. The expense per student, for this element of his education, would be \$17.81 per year.

These shops would still be available for evening classes, which would add, giving each student three two-hour lessons per week, one hundred and ninety-two students per year to their teaching capacity, and thus reduce the average cost per pupil. Having the proper rooms, the cost of fitting up this series of shops would not, at the outside, cost over \$20,000. To fit up a shop for

teaching carpentry and joinery to sections of sixteen would not cost, including sixty-four sets of tools, over \$1,500. If most of the tools should be used in common—or better, if the same set should only be used by the students, who, in succession, occupy the same bench—the expense would be under \$500.

This system of mechanic-art teaching is earnestly commended to all, with the assurance, that, in the hands of competent and faithful teachers, it will prove entirely successful, not only on educational, but also on economical grounds.

Institute of Technology,
Boston, January 22, 1878

JOHN D. RUNKLE

SOURCE REFERENCES

1. Clarke, Isaac Edwards. *Art and Industry*. U. S. Bureau of Education, Washington, D. C., 1898.
2. *Report of the Commission on Industrial Education* made to the Legislature of Pennsylvania, Harrisburg, 1891.
3. *Eighth Biennial Report of the Superintendent of Public Instruction of the State of Illinois*, 1869–1870.
4. Walker, Francis A., editor. *Reports and Awards International Exposition, 1876*. Government Printing Office, Washington, 1880.
5. *Handbook of the Kansas State Agricultural College*, 1874.
6. Coates, Charles Penney. *History of the Manual Training School of Washington University*. Bulletin, 1923, No. 3. U. S. Bureau of Education, Washington, D. C.
7. Woodward, C. M., *The Manual Training School*. D. C. Heath & Co., Boston, 1887.
8. Ham, Charles H. *Manual Training, the Solution of Social and Industrial Problems*. Harper and Brothers, New York, 1886.
9. *Forty-first Annual Report of the Board of Education, State of Massachusetts*, 1876–77.
10. *Report of the Commission Appointed to Investigate the Existing Systems of Manual Training and Industrial Education, State of Massachusetts*, 1893.
11. *Forty-fifth Annual Report of the Board of Education, State of Massachusetts*, 1880–81.
12. *Manual Education in the Polytechnic School of Washington University*. (A pamphlet loaned by Dr. Woodward and parts of it copied), 1877.
13. *Report of the United States Commissioner of Education for the year 1893–94*. Government Printing Office, Washington, D. C.

CHAPTER X

MANUAL TRAINING IN SECONDARY SCHOOLS

74. A New Type of High School. The earliest and also the most distinctive feature of the manual-training movement in America was the manual-training high school. It is a notable fact that this appeared in complete typical form in the very first institution of its class, the Manual Training School of Washington University, in the City of St. Louis. On that account, to know this particular type of school, one needs only to study this first school and a few later variations from the original.

In the previous chapter, attention was called to Professor C. M. Woodward's vision of a new type of secondary school which should give as important a place in its course of instruction to educationally organized shopwork as to mathematics and science. It was the continued pursuit of this vision that brought into being the Manual Training School of Washington University.

In the establishing ordinance, dated June 6, 1879, the purpose of the school was stated thus:

Its object shall be instruction in mathematics, drawing, and English branches of a high-school course, and instruction and practice in the use of tools. The tool instruction, as at present contemplated, shall include carpentry, wood turning, patternmaking, iron chipping and filing, forge work, brazing and soldering, and the use of machine shop tools, and such other instruction of a similar character as may be deemed advisable to add to the foregoing, from time to time.

The students will divide their working hours, as nearly as possible, equally between mental and manual labor.

They shall be admitted, on examination, at not less than fourteen years of age, and the course shall continue three years. (1—5)

An amplifying statement followed the ordinance in the original prospectus of the school. On account of the varied claims made later for this type of school, these original

statements of purpose are of interest to the student of education:

The Manual Training School owes its existence to the conviction, on the part of its founders, that the interests of St. Louis demand for young men a system of education which shall fit them for the actual duties of life in a more direct and positive manner than is done in the ordinary American school.

St. Louis already has large manufacturing as well as commercial interests, and we all expect to see these interests greatly increase. We see in the future an increasing demand for thoroughly trained men to take positions in manufacturing establishments as superintendents, as foremen, and as skilled workmen. The youths of today are to be the men of the next generation. It is important that we keep their probable life work in view in providing for their education. Excellent as are our established schools, both public and private, it must be admitted that they still leave something to be desired; they do not, and probably they can not, cover the whole ground.

This conviction of the incompleteness of present means and methods of education has found utterance in many ways. Some of the best friends of education have expressed themselves in strong and suggestive language. All such agree in the conclusion that the main deficiency is in the direction of manual education.

Hence, as it is often said, nearly all our skilled workmen are imported. Our best machinists, miners, weavers, watchmakers, iron workers, draftsmen and artisans of every description, come from abroad; and this is not because our native-born are deficient in natural tact or ability, nor because they are in point of fact above and beyond such occupations, but because they are without suitable means and opportunities for getting the proper training. (1—7, 8)

While it is true that this manual-training school seemed to be born full-fledged in plan, organization, and courses of instruction, it should be recalled that, during the two years previous to the opening of the school, courses in shopwork had been rapidly taking definite form at Washington University. Under the heading "Manual Education" in the University catalog for 1878-79 appears the statement that "all the regular polytechnic students devote to shopwork an average of two afternoons per week" and that "a class of about thirty students from the Academy" had been given instruction in woodworking twice a week. Furthermore, it is announced that Charles F. White, a graduate of the Worcester Free Institute, who had done graduate work at Stevens Institute of Technology, had been made superintendent of the shops. (2—89) Mr. White had examined the exhibit of the Russian System at the Centennial Exposition, and had

designed a series of exercises for machine tools at Stevens Institute, before coming to Washington University. Thus it was that the man who, during his eight years at St. Louis, developed the courses in woodworking and machine tool work for the Manual Training School, which remained almost unchanged for many years, had spent two years in organizing

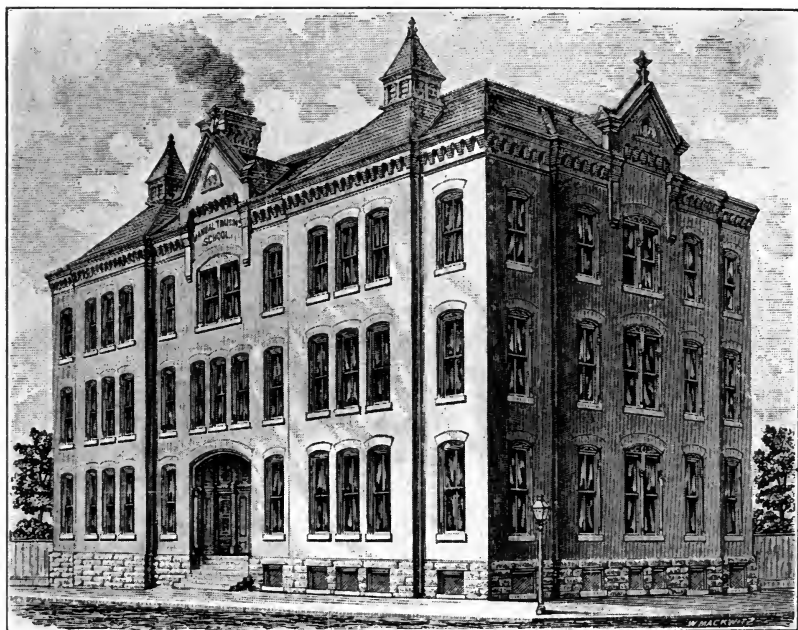

FIG. 112. MANUAL TRAINING SCHOOL, ST. LOUIS, 1880

courses in the "old dormitory" shops, (cf. 73) and had even gained experience in teaching shopwork to students of secondary-school grade. (3—28) Moreover, in that same year, it was stated that "no branch of study has been omitted from the theoretical work in consequence of the addition of shopwork." The standard of scholarship had not been lowered on account of the introduction of shopwork. (2—89)

From these statements, it is clear that, in devising the curriculum and the time schedule for the Manual Training School, Dr. Woodward was working with a background of

considerable experience. He was reasonably sure of some of the most vital factors entering into his scheme for the new school.

The building for the new school, Figs. 112, 113, 114, was completed during the summer of 1880. Its equipment, how-

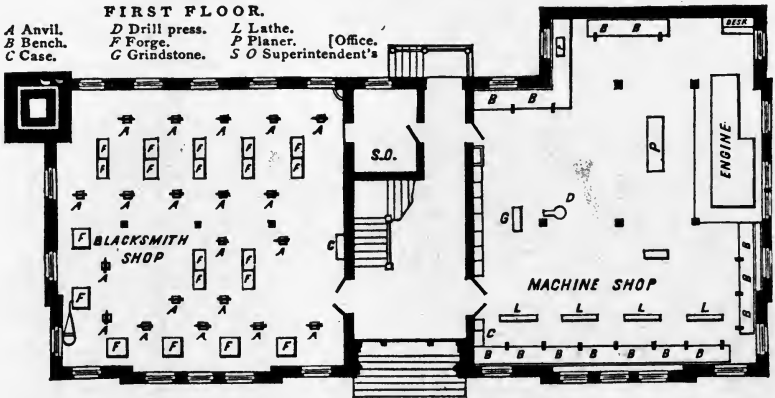

FIG. 113. FIRST-FLOOR PLAN, ST. LOUIS MANUAL TRAINING SCHOOL

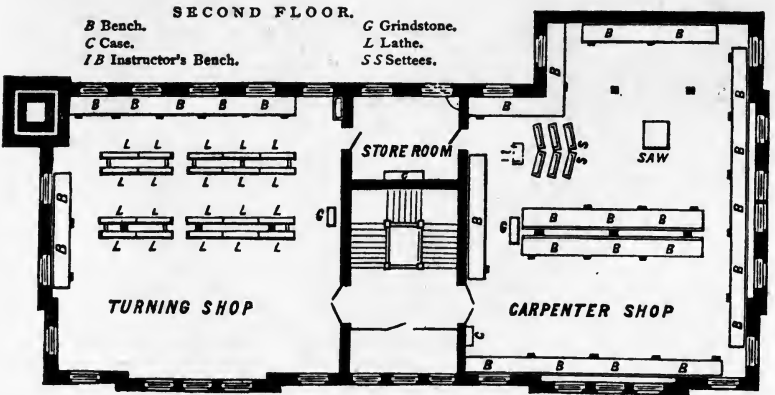

FIG. 114. SECOND-FLOOR PLAN, ST. LOUIS MANUAL TRAINING SCHOOL

ever, was not all purchased that year but was added as fast as needed. At first, the entire third floor was used for drawing and academic subjects. Three years later, an addition to the building provided for the academic work, and the third floor of the original building was given over to a needed

additional shop, to a physical-science laboratory, and a drawing room. Each shop was equipped to accommodate a class of twenty pupils all doing the same kind of work at one time. Figs. 115, 116, 117. Each pupil was provided with a set of edge tools for his exclusive use. These were kept in a locked drawer, thus making it possible to hold him responsible for their care and safety. Additional tools were provided for each class as needed.

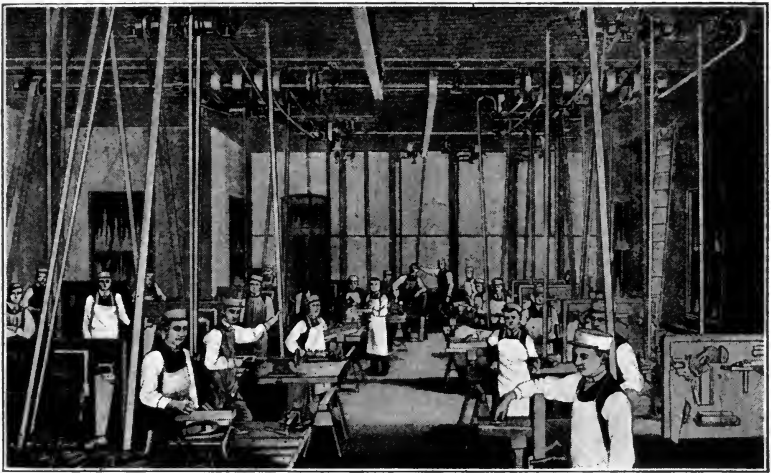

FIG. 115. WOODWORKING SHOP, ST. LOUIS MANUAL TRAINING SCHOOL

The school opened on September 6, 1880, with about 50 boys. The total enrollment during the first year was 67. The second year 61 new pupils formed the first-year class and 46 the second-year class. The enrollment the third year, with three classes, was 176. The 200 mark was passed the fourth year and, for more than twenty-five years, the enrollment was between 200 and 316. (3—39)

Each candidate for admission was examined in arithmetic, geography, spelling, and penmanship, and the writing of good English.

The course of instruction, the making of which was a most important factor in the success of the school and, in fact,

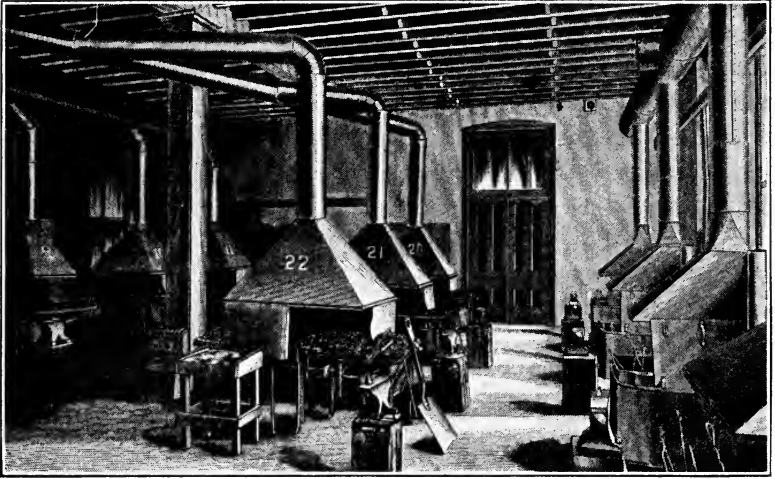

FIG. 116. BLACKSMITH SHOP, ST. LOUIS MANUAL TRAINING SCHOOL

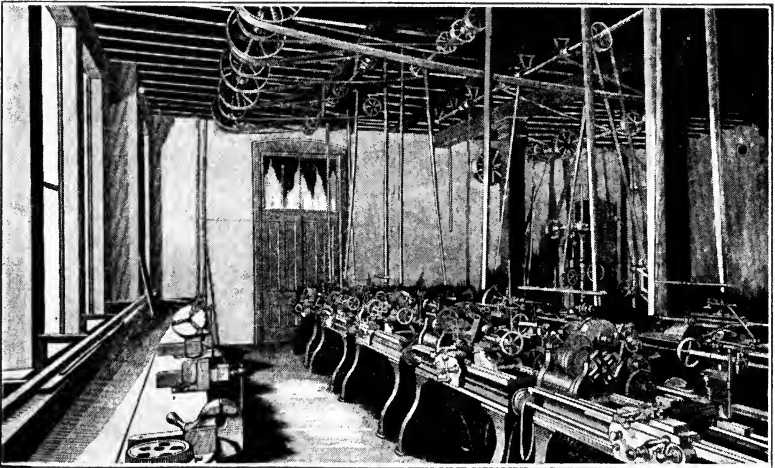

FIG. 117. MACHINE SHOP, ST. LOUIS MANUAL TRAINING SCHOOL

constituted the distinctive feature of this new type of secondary school, consisted of five fundamental lines of study carried on simultaneously:

1. Mathematics
2. Science
3. Language
4. Drawing
5. Shopwork

Quoting from an early catalog, "The course of instruction covers three years, and embraces five parallel lines—three purely intellectual, and two both intellectual and manual—as follows:

First—A course of pure mathematics, including arithmetic, algebra, geometry, and plane trigonometry.

Second—A course in science and applied mathematics, including physical geography, botany, natural philosophy, chemistry, mechanics, mensuration, and bookkeeping.

Third—A course in language and literature, including English grammar, spelling, composition, literature, history, and the elements of political science and economy. Latin and French are introduced as electives with English or science.

Fourth—A course in penmanship, freehand and mechanical drawing.

Fifth—A course of tool instruction, including carpentry, wood turning, molding, brazing, soldering, forging, and bench and machine work in metals. (4—177)

From this outline, it is clear that primarily the school did not aim to prepare boys for college but, by electing a foreign language, three years of college preparation were possible in the school.

Another important factor in the success of the school was the economical time schedule adopted. There were five subjects each day for every boy and one of these, shopwork, required more time than any of the others to be effective. So the day was divided into six one-hour periods, and two of these, called a double period, were given to shopwork. At first, a 20-minute period for study each day was taken out of one of the hours for academic work; as, for example, 20 minutes for study and 40 minutes for algebra. In a similar way, twenty minutes were provided for a recess or lunch period. All was done in the six hours from nine to three,

TABULAR VIEW OF DAILY EXERCISES.

FIRST TERM, 1884-5.

Class.	Section.	9:00 till 11:00.	11:00 till 1:00.	1:00 to 1:30.	1:30 till 3:30.
FIRST.	A.	Machine Shop.	Mechanics.	Geometry.	French.
	B.	Drawing.	Machine Shop.		Drawing.
	C.	Mechanics.	Drawing.	History and Literature.	Latin.
MIDDLE.	A.	Forging Shop.	Physics.	Algebra.	Machine Shop.
	B.	Algebra.	Forging Shop.		Drawing.
	C.	Drawing.	Latin.	Physics.	History and Literature.
JUNIOR.	A.	Woodworking Shop.	Arithmetic.	Science.	Forging Shop.
	B.	Lessons in English.	Woodworking Shop.		Drawing.
	C.	Drawing.	Woodworking Shop.		History and Literature.
	D.	Latin.	Arithmetic.	Science.	Science.
					Lessons in English.
					Woodworking Shop.

In the Junior Class Penmanship takes the place of Drawing once a week.
There is continual practice in English Composition in connection with Language and Literature.

C. M. WOODWARD, Director.

FIG. 118. TIME TABLE, ST. LOUIS MANUAL TRAINING SCHOOL

except the home study which was necessary. (5—179) After a little experience, however, the school session was extended to 3:30, a half hour recess allowed at lunch time, and no study hours scheduled, Fig. 118. (6—23) This time schedule, which permitted one teacher of shopwork to give instruction to three sections a day, was economical, and because every pupil was kept busy all the time, there was a business-like atmosphere about the school, which was quite in harmony with its purpose.

Not long after the school opened, the following explanation was made of the method employed in teaching the shopwork:

The shop instruction is given similarly to laboratory lectures. The instructor at the bench, machine, forge, or anvil, executes in the presence of the whole class the day's lesson, giving all needed instructions, and at times using the blackboard. When necessary, the pupils make notes and sketches, and questions are asked and answered, that all obscurities may be removed. The class then proceeds to the execution of the task, leaving the instructor to give additional help to such as need it. At a specified time, that lesson ceases; the work is brought in, commented on, and marked. It is not necessary that all the work assigned should be finished: the essential thing is, that it should be well begun and carried on with reasonable speed and accuracy.

It is almost useless to say that the personal characteristics of pupils are even more marked in this work than in any ordinary recitation, from the fact that no textbooks are used, nor is there previous study. The length of time required by different pupils in a large class for the doing of a specified piece of work varies considerably. Hence, additional lessons or constructive work are arranged for the brighter and quicker members.

. . . The use of the tool may be well taught by a large variety of exercises, just as a knowledge of bank discount may be gained from the use of several different examples. No special merit can be claimed for a particular example; neither can a particular model, or series of models, have any great value. No good teacher is likely to use precisely the same set twice.

Again, the *method* of doing a piece of work, and not the finished piece, may be the object of a lesson. (5—182)

At this same early period in the history of the school, the theory of the shopwork was set forth at considerable length as follows:

The application of the educational idea to mechanic arts is strictly analogous to its application to chemistry and physics. In each, the use of apparatus and the treatment of material is taught by systematic experiments in suitable laboratories. In each, everything is arranged for the purpose of giving instruction in the principles involved, and for acquiring skill in ma-

nipulation, and not for the sake of the production of salable compounds of either drugs or apparatus.

Chemical laboratories might be manufactories, and mixtures might be made for sale, but the efficiency of such a laboratory for the purpose of education would be very small. So a manufacturing establishment can be made a place for instruction in the use of tools, but its cost would be great in proportion to its capacity, and the variety of work would be limited by its business.

The scope of a single trade is too narrow for educational purposes. Manual education should be as broad and liberal as intellectual. A shop which manufactures for the market, and expects a revenue from the sale of its products, is necessarily confined to salable work; and a systematic and progressive series of lessons is impossible, except at great cost. If the object of the shop is education, a student should be allowed to discontinue any task or process the moment he has learned to do it well. If the shop were intended to make money, the students would be kept at work on what they could do best, at the expense of breadth and versatility.

It is claimed that students take more interest in working upon something which, when finished, has intrinsic value, than they do in abstract exercises. This is quite possible, and proper use should be made of this fact; but, if all education were limited to such practical examples, our schools would be useless. The idea of a school is that pupils are to be graded and taught in classes; the result aimed at being not at all the objective product or finished work, but the intellectual and physical growth which comes from the exercise. Of what use is the elaborate solution in algebra, the minute drawing, or the faithful translation, after it is well done? Do we not erase the one, and burn the other, with the clear conviction that the only thing of value was the discipline, and that that is indestructible?

So in manual education, the desired end is the acquirement of skill in the use of tools and materials, and not the production of specific articles: thence we abstract all the mechanical processes and manual arts and typical tools of the trades and occupations of men, arrange a systematic course of instruction in the same, and then incorporate it into our system of education. Thus, without teaching any one trade, we teach the essential mechanical principles of all.

In accordance with the foregoing principles, the shop training is gained by regular and carefully graded lessons designed to cover as much ground as possible, and to teach thoroughly the uses of ordinary tools. This does not imply the attainment of sufficient skill to produce either the fine work or the rapidity of a skilled mechanic; this is left to after-years. But a knowledge of how a tool or machine should be used is easily and thoroughly taught. The mechanical products or results of such lessons have little or no value when completed, and hence the shops do not attempt to manufacture for the market.

As has been said, work of immediate utility is of greater interest to students than abstract lessons. Such work has an undoubted value, and is in many ways desirable, provided it does not hinder or interfere with regular instruction. Opportunities for such constructive work are constantly occurring. The wants of a large institution are many, and, when they can be

supplied by student skill, it is a benefit to all concerned. In this way, outside the stated hours, pupils have the means of applying their knowledge and of gaining additional practice. The yearly aggregate of such productions is quite large, and it affords undeniable evidence of the efficiency of systematic instruction. (5—180—182)

A more detailed statement concerning the shopwork was included in a paper by Professor Woodward read before the American Society of Mechanical Engineers. From this paper, the following paragraphs are quoted:

The shop practice extends over a very wide field; but, like the drawing, which runs parallel with it, it is all required of every boy in the school, no matter what his plans for the future may be. It occupies two hours a day for five days each week.

The three hundred and eighty hours of the first year are devoted to wood, at the bench and at the lathe. Joining, with wood carving, gluing, inside and outside turning, forms of beauty and forms of strength, constitute the series. The year ends with the construction of an article, original or copied, which shall embody as many of the steps already learned as possible. Incidentally, the pupils keep up the stock of handles, mallets, clamps, trestles, and shelving in the establishment, though the great majority of exercises are of a purely abstract character.

The size of a shop division is limited to twenty-four boys, under the charge of a single teacher, and the daily lesson is uniform for the division. A working drawing of the piece or model required is first made and explained by the teacher of the division. Every boy copies the drawing in his special book, and henceforth, works from the drawing. The piece is then executed by the teacher in the presence of the class. Attention is called to the order in which the steps are taken, what tools are used, and how new processes are combined with old ones. The boys then execute the task, each for himself, with or without special direction or help from the teacher. Boys who work rapidly and well put their spare time after finishing their exercises into "extras," which generally combine the steps already learned in some article of use or beauty. The slowest boy generally hands in an unfinished piece. The results are criticised, compared, and graded on an absolute scale where one hundred per cent means reasonable perfection.

The aim is to master the range of every tool and to cultivate the habit of analyzing complicated processes into simple elements. A high degree of skill is not aimed at, the chief immediate object being an intelligent mastery of every step and every tool.

By a similar method, forging is learned during the middle year. The elementary processes of the forge are learned one at a time, with just enough practice to fix them indelibly on the mind and to secure a moderate degree of skill. We have found it extremely useful in giving exact knowledge of forms, and in teaching how to strike and how to hold pieces under the hammer, to use bars of cold lead in a preliminary exercise. The time apparently lost on a lead exercise is more than made good by the material and time saved in the

subsequent forgings of iron and steel. The necessity of keeping up the supply of forging tools, and of the construction of a set of lathe tools, cold chisel, and steel dog gives all the variety necessary for a course of mere instruction. The size of a working division during the second year is reduced to twenty-two; hence the shop contains but twenty-two forges, anvils, and sets of tools. A total of only two hundred and eight-five hours is given to the forging shop. The remaining ninety-five hours of the second year are given to pattern-making, molding, casting (with plaster or lead), brazing, and soldering. In connection with soldering comes practice in cutting sheet metal for special shapes, and spinning. This work is done in strict connection with their drawing of intersections, and the developments of surfaces.

The shop practice of the third year is in the machine and fitting shop. The maximum size of a working division is here reduced to twenty; and yet it has been found impossible to adhere strictly to uniform lessons, for the reason that it is practically out of the question to furnish twenty complete sets of machine tools. We have found our wants fairly met by twelve engine lathes, four speed lathes, two drills, two planers, and twelve vises. As one man is always detailed to keep the tool shop, nineteen are to be kept at work at once. Nevertheless, a large degree of uniformity is secured by means of systematic class instruction on the different tools, and then systematic rotation in the exercises. In the use of the planers and drills, a boy is first learner and then teacher. The series of exercises which we use are the results of large experience in devising such work as shall prove most instructive, and best serve to develop the full capacity of every hand and machine tool. The exercises occupy fully four fifths of the year, and include the use of every tool in the shop.

The last few weeks are devoted to construction. In some cases, new patterns are constructed; in others old patterns, made during the second year, are used; and, from the castings, (made elsewhere) articles of some complexity and real utility are constructed. During the present year, the senior class is engaged in the construction of three upright engines, several jackscrews, an emery grinder, and several pieces of brass work. The abstract exercises, however, covered the shopwork from the first of September to the middle of April. These engines and other articles are not made with any view to an income. Our purpose in their construction is to give the students themselves an opportunity to see how fully their exercises have prepared them for such constructive work and, on the other hand, to teach them that, no matter how comprehensive their experience may be, a new article may involve new problems which can be solved only by thoughtful study and the exercise of good judgment.

As to our policy of not carrying on a commercial establishment; of taking no contracts; and of not setting out to manufacture for any market: reference will be made later on. It may be now said that we have found our present system of uniform exercises: 1. More fruitful in general skill; 2. Better adapted for teaching method, and precision; 3. More economical as admitting of a larger number of students simultaneously under one instructor.

Such, then, are the chief features of the Manual Training School. It was not established, nor is it conducted, as a school for the primary training of mechanical engineers alone. It is a school for general training. It is assumed

that pupils entering its junior class are too young and undeveloped to decide the all-important question: what occupation or career in life shall he select? By the end of a three year's course, however, the bent or natural aptitude of a boy is generally found, if he has one. If he combines a love for practical work with strong mathematical power, then he has the prerequisites of an engineer. (10—IV, 44, 45)

To complete the picture of shopwork instruction as conceived by Professor Woodward, one should read Source Material X A on "The Teacher of Tool Work."

The course of tool exercises in woodworking as taken from *The Manual Training School* by Woodward, published in 1887, was as follows:

1. Use of jack plane and try-square in squaring up a piece from rough stock.
2. Use of crosscut saw; laying out and sawing
3. Rip and crosscut sawing; laying out and sawing
4. (a) Cross-lap joint, (b) end-lap joint, (c) miter joint
5. Slip joint
6. Double slip joint
7. Mortise-and-tenon joint, also double mortise-and-tenon joint
8. Sawing out tenons
9. A miter joint with an open double mortise-and-tenon
10. A half-dovetailed joint halved together
11. A dovetail joint with a single tongue
12. An oblique mortise-and-tenon joint with a pin
13. A half-dovetailed mortise-and-tenon joint with a key
14. A beveled corner piece of a frame, with a blind mortise for a half-dovetailed tenon
15. A half-blind dowel joint
16. Triangular frame
17. Hexagonal frame
18. A rafter joint
19. A dovetail joint with several tongues
20. A dovetail joint with a miter
21. A false double-dovetailed joint
22. A bench project (8—38—49)

Before receiving the diploma of the school, each boy was required to "execute a project satisfactory to the faculty of the school." This consisted of the construction of a machine. This machine completely finished must be accompanied by a full set of the working drawings from which the machine was made. Either the patterns for the castings or a description of how to make them was required to be submitted with the machine. (5—178)

75. A Period of Controversy. The decade from 1880 to 1890 was a period of marked progress and of heated discussion. The new type of high school was a popular success from the first. It filled a recognized gap in the American school system; it met a real need. Yet, in doing so, it aroused the active and sometimes highly emotional opposition of some of the more conservative educators who did not recognize the value of manual training in general education and feared the breaking down of the academic standards already established. While the discussion was heard in many places, it centered in the conventions of the National Education Association, where various phases of industrial education were discussed in general sessions and also in an industrial-education department.

The controversy received its first strong impulse at the annual summer convention at Saratoga, New York, in 1882. At this meeting, a committee on industrial education made an important report. This committee was made up of seven New England educators, of which Francis A. Walker, president of the Massachusetts Institute of Technology, was chairman, and John S. Clark of Boston was the secretary. They recommended (a) the development of sense perception through the study of models and natural objects, (b) the introduction of experimental work in natural science in the grammar grades, (c) the systematic teaching of drawing, and (d) "the introduction into grammar and high schools of instruction in the use of tools, not for their application in any particular trade or trades, but for developing skill of hand in the fundamental manipulations connected with the industrial arts, also as a means of mental development." (7—I, 886) The recommendation concerning tool instruction was "vigorously discussed." Dr. E. E. White, at that time president of Purdue University, said that "the doctrine that the public schools should cover the whole domain of education saps the very foundation of the public-school system, puts a magazine under it, and then lays a train out to fire it." A. P. Marble, superintendent of public schools at Worcester, Massachusetts, sought to kill the effect of the

report by ridicule. Among other choice bits, he gave the audience this one: "There is no information stored up in the plow, hoe handle, steam engine, but there *is* information stored up in books." (7—I, 887)

John S. Clark said that there should be no issue between industrial training and literary training; both were needed in a sound course of mental training. Both are equally demanded by the social conditions of any highly organized community. Dr. C. M. Woodward emphasized the importance of "making good workmen" as well as "educated intellects." The advocates of manual training desired to enrich the curriculum, not to curtail it, he said.

By this time, Dr. Woodward's statements and his school had become the center of discussion. Every address he made was watched by the opposition for unsound theories and overstatements of facts. Those who were open-minded and accepted his invitation to visit the school and see for themselves, were pleased with what they saw, while others picked at his every phrase that did not accord with their own theory or practice. For example, at the Missouri State Teachers' Association in June, 1883, his opponent asserted "that there could be no such thing as general training in the use of tools"; there were, he declared, no fundamental principles. And again he took the position that "whatever energy or strength was absorbed in manual-training exercises with tools was just so much energy withdrawn from mental training." To answer this, Dr. Woodward made an analysis of tool processes and pointed to the results with the boys in his St. Louis school.

On account of such opposition, on the one hand, and his encouraging experiences with the boys in the Manual Training School, on the other, Dr. Woodward began to say less about the original purpose of the school, which was to give boys a better secondary-school start toward a variety of occupations in the industries, and more about the general educational value of manual training, whatever a boy's future occupation might be. About the time of the graduation of the first class from the Manual Training School, Dr. Woodward said:

My own conclusion, based upon the observation of the influence of manual education for at least eight years, is that not only does our workshop not detract from the interest boys take in books, but it stimulates and increases it, either directly or indirectly. In mathematics, physics, mechanics, and chemistry, the help is direct and positive. Note, for instance, the mental arithmetic involved in the execution of a pattern from a working drawing. No one can learn from a book the true force of technical terms or definitions nor the properties of materials. The obscurities of the textbooks (often doubly obscure from the lack of proper training on the part of the author) vanish before the steady gaze of a boy whose hands and eyes have assisted in the building of mental images. (7—I, 890)

In July, 1883, at the convention of the National Education Association, held again at Saratoga, Dr. Woodward spoke on "The Fruits of Manual Training." This address later constituted Chapter VIII in his book, *The Manual Training School*. The claims for manual training in this address were: (a) larger classes of boys in the grammar and high schools; (b) better intellectual development; (c) a more wholesome moral education; (d) sounder judgments of men and things, and of living issues; (e) better choice of occupations; (f) a higher degree of material success, individual and social; (g) the elevation of many of the occupations from the realm of brute, unintelligent labor, to positions requiring and rewarding cultivation and skill; (h) the solution of labor problems." (8—203)

In 1884, the National Education Association held its annual convention at Madison, Wisconsin. An outstanding feature of that meeting was a large exhibit of school work, including several displays in the field of industrial education which attracted much attention. These were from The St. Louis Manual Training School, The School of Mechanic Arts of the Massachusetts Institute of Technology, The Illinois Industrial University, and Purdue University. (9—95—98)

In a report summarizing the exhibits, Dr. William T. Harris said, "All will rejoice that the matter of fitting for one's vocation in life is to become a matter of schooling rather than of apprenticeship. Intelligent skill will supplant mere 'knack.' Valuable time will be saved for general studies. Educated workmen from manual-training schools will furnish overseers that can teach as well as boss their subordinates.

It is not necessary, as some think, to introduce manual training into the common school. What we want is the manual-training school side by side with the high school as an independent institution for the preparation of youth for their vocation." (9—85)

The above opinion expressed by Dr. Harris is especially significant in view of the fact that in the years that followed 1884, he was the ablest of the opponents of manual training in general education. It is interesting to notice that his ideas were more European than American at that time, so far as special schools were concerned. He wanted what are now called vocational schools.

At this meeting, Dr. Woodward was president of the industrial department. Three addresses were given in this department which, taken together, may be looked upon as the most comprehensive and enlightening statement of the case for manual training that had been made up to that time. In "A Layman's View of Manual Training," Col. Augustus Jacobson of Chicago presented the viewpoint of the industrialist who looked upon manual training as "bread-winning training." He recognized that it did not teach trades but it did teach the rudiments of all trades. And he said, "Skill with small intelligence increases very slowly. Coupled with great intelligence, skill increases very rapidly." (9—299) "The wealth of the nation depends upon skill." (9—293)

In sharp contrast with this were the claims of manual training as a means of mental culture made by Dr. Felix Adler of New York City. The title of his address was given as "Technical and Art Education in Public Schools as Elements of Culture." Dr. Adler's introductory paragraph is quoted in full because of its importance at that stage in the discussion of the place and value of manual training in public education:

It should be clearly understood at the outset of this paper, that the method of instruction which it is my purpose to advocate is not any scheme of "industrial education," in the sense in which that phrase is commonly employed. There is, in certain quarters, a great outcry against our public schools, because they do not turn out skillful wage earners. The demand is made that the

system of instruction shall be of a more "practical" character; that it shall furnish a more purely material equipment for the exigencies of life, than is the case at present. To remedy this deficiency, various kinds of technical work have been from time to time introduced into schools in different parts of the country. Carpentry, printing, shoemaking, and art metalwork have been interjected into the school curriculum, in order to supply the want which is felt to exist and place the school abreast of modern requirements. This has not been done, however, without determined opposition—an opposition, let me hasten to say, with which I fully sympathize. I believe that the State violates the rights of the children, when it undertakes to prescribe their future career during the school age. The business of the public school is not to educate operatives, any more than it is to educate merchants, or clergymen, or physicians. The schools are designed to supply those elements of general culture which are necessary to all men and women alike. Unless, therefore, it can be demonstrated that technical work and art work *are* elements of that broad culture which all human beings ought to possess, these novelties should by no means be admitted into the curriculum. It is the purpose of this paper to advance the claim that tool instruction, workshop lessons—in a word, technical training and artistic modeling—are essential elements of general culture. Leave the direct material applications entirely out of account; suppose there were no factories in the world; suppose that all the millions of children educated in our public schools were to be gentlemen and ladies at leisure: I should, in that case, plead none the less strenuously for the introduction of technical and art work as an indispensable feature of the school system. I should plead for it then, as now, simply because of its broadening, humanizing effect; because it quickens into activity certain faculties of human nature which too commonly lie dormant; because, instead of the present one-sided development, it is a step further in the direction of that all-sided development which is the ideal in education. The cry for "industrial education," in the ordinary acceptance of the term, is a false cry. It gives rise to the suspicion that the school is to be debased into a mere training place for the material interests of life. At the very antipodes of such a system stands the reform that I would urge. I wish to insist strongly upon this radical distinction, and to set sharply and clearly before the mind of all the fundamental proposition that, though the busy hum of every workshop should be hushed into silence, though the earth nourished her children without requiring their labor, still, technical and art instruction would be as vitally important as ever, simply as elements of mind culture. (9—308, 309)

Dr. Adler then told in considerable detail how handwork aids mental development, and he illustrated his statements by relating experiences in the Workingman's School of New York City.

The third paper on this notable program was by Professor John M. Ordway of the Massachusetts Institute of Technology, Boston. His subject was "Handwork in the School." He brought together many facts concerning handwork in Euro-

pean schools, and restated the results of experiments in such places as Boston and St. Louis.

That same year a notable address was given at the annual meeting of the American Institute of Instruction by James MacAlister, superintendent of public schools in Philadelphia. In his address, he said:

A word or two must be added concerning the proper sphere of the manual-training school. It does not mean the fitting of pupils for special industrial occupations. Boston, Philadelphia, New York, may find it to their advantage to establish schools for the training of artisans, just as they have schools for the training of engineers and lawyers and doctors; but the moment the manual-training school undertakes to do this, it will forfeit its place as a part of the general educational system. The establishment of trade schools is a different question altogether; manual training, as I understand it, aims at general results. Its purpose is to develop human beings on the executive side of their nature as well as on the receptive. Its aim is to equip a boy so that, when he gets in the world, he will be able to *do* as well as to *think*. The training is to be so generalized in character that it will prove an accomplishment which will stand its possessor in good stead wherever manual skill can be made available. (10—II, 1178)

While such claims as were made at the Madison meeting were increasingly heard, the conservative leaders in education were opposed to the introduction of manual training as a part of the system of general education. They continued to look upon it as special trade or vocational training, and, at that time, there was quite general acceptance of the idea that public funds should not be expended for vocational training, as such. John W. Dickinson, secretary of the Board of Education in Massachusetts, in his report issued in 1885, said:

Our public schools do not propose to train their members directly for the practice of any trade or any profession. They propose to do much more than that, to give to the children the opportunity of obtaining that knowledge and that cultivation of mental power which will, in due time, bring them to the various occupations of life, ready to pursue them in the most intelligent and most productive manner. (10—1134)

In another paragraph of this report, however, he did show that he was open to further proof when he said, in referring to the handicrafts, "It is doubtful if such instruction can for the present enter as a considerable element into our public-school work. Cherishing toward it, however, a hospitable spirit, we may cordially welcome the fruits of experience."

On May 29, 1885, before the New England Association of School Superintendents, A. P. Marble, of Worcester, read a paper on "Industrial Education as a Part of the Common School Course," which, though punctuated with thrusts at the shifting claims and inconsistencies of the advocates of manual training and at the vagaries of theoretical educational reformers in general, probably did fairly represent the attitude of many of the leading schoolmen. His conclusions were summarized as follows:

I. The common schools have a sphere of their own, and it does not include shops-in-the-basement.

II. Industrial education, in the best possible forms is a part of the course—in the study of drawing.

III. Incidentally, and in any line for which he is fitted, every teacher should secure a certain manual dexterity.

IV. The best means of securing an industrial education is the systematic, but not formal, study of local industries.

V. For teaching trades, special schools should be experimented with by private enterprise; they should be supported by the public-school authorities only after their practicability and usefulness shall have been established, and in response to a real public demand. (10—921)

The fall months of 1885, Dr. Woodward spent in England and on the continent of Europe. The occasion of his going was an invitation to discuss manual training at an educational conference in Manchester, England. (cf. 48) On December 16 of that year, Dr. Woodward spoke at a public gathering in Huntington Hall, Boston, at the invitation of the governor of the state, the mayor, the superintendent of public schools of Boston, the president of the Massachusetts Institute of Technology, the secretary of the State Board of Education, and other leading citizens. Dr. Woodward very adroitly began his address by quoting from the highly honored New Englander, Ralph Waldo Emerson: "We are students of words; we are shut up in schools and colleges and recitation room from ten to fifteen years, and come out at last with a bag of wind, a memory of words, and do not know a thing. We cannot use our hands, or our legs, or our eyes, or our arms. . . . In a hundred high schools and colleges, this warfare against common sense still goes on." (10—II, 772—773) During this notable address, Dr. Wood-

ward met, point for point, the objections urged against manual training. It was on this occasion that Dr. Woodward gave utterance to the oft-quoted epigram about educating the whole boy. He said, "My educational creed I put into six words: *Put the whole boy to school.*" (7—897)

The year 1886 witnessed another notable discussion—or rather a discussion by notable men—at one session of the National Council of Education at Topeka in July. At that meeting a committee consisting of Dr. Selim H. Peabody, president of Illinois Industrial University; Professor John M. Ordway, of Tulane University, New Orleans; Dr. Emerson E. White, then superintendent of public schools, Cincinnati; and George T. Fairchild, president of Kansas State Agricultural College, made a report on "The Pedagogical Value of the School Workshop," which was discussed at length by many leaders in the Council. The report itself was an effort to define school shopwork, indicate its functions in education, and so eliminate misunderstandings. It was, however, in such general terms and, in some respects, so far from being a vital message, that its purpose was accomplished only in a very minor degree. Moreover, the discussion that followed its presentation revealed that the members of the committee did not agree on the interpretation and application of the report. Probably the most important conclusion expressed in the discussion was in a statement by Dr. White: "The workshop is deserving a place in the school, only as an educational instrument—not to teach trades. Hence, if the workshop enters the school, it must be for its educational value." (11—313) Yet he admitted that he thought it ought not to be introduced into public schools. He was not yet convinced of its value in general education. (11—314) Dr. Peabody, however, chairman of the committee, while emphasizing the pedagogic factor in manual training, would keep in mind also the economic or practical factor.

But it was at the Chicago convention of the National Educational Association in 1887 that a definite note of confidence was struck that marked the turning point in the series of discussions. On that occasion, General Francis A.

Walker, president of the Massachusetts Institute of Technology, read a paper on "Manual Education in Urban Communities," in which he showed why the city boy needs manual training to make up for the lack of certain experiences which the country boy enjoys, and then definitely recommended shopwork for boys in the grammar grades. He said, "One thing seems reasonably well established, namely, that carpentry and wood turning are the arts with which we may most advantageously begin with grammar-grade pupils. Work in these lines is sure to interest both scholars and parents." (12—200) Concerning manual training in the high school, he said:

Whatever other arts may, in the development of this system, come to be associated with carpentry and wood turning in the grammar schools, it appears to me that, at the very beginning, we may demand a complete course of both wood and metalworking for that smaller number of advanced pupils who go forward into the high school. If it is for the interest of the State that these young persons shall, at the public expense, be further educated and cultivated on one side of their minds, it is not equally, but doubly, desirable that the education and cultivation of their other powers and faculties should be kept up in the high school. It is little less than a shame that we should graduate from these schools pupils who are highly accomplished in language, composition, and declamation, but are less keen in perception, less careful in observation, weaker in practical judgments, with less of visual accuracy, less of manual dexterity, less of the executive faculty—the power, that is, of doing things instead of merely thinking about them, talking about them, and writing about them—than the children of the ordinary ungraded district school.

Whatever views one may hold of the mutual relations of the child and the State in the grammar school, it can be gainsaid by no one that, if the community is to be called upon to carry the more favored children forward through long and expensive courses of advanced education and training, those men who, on behalf of the community, direct the schools of this class have the absolute right to impose whatever terms and conditions, to exact and to withhold whatever the public interest may require. Cherishing the views I do as to what constitutes a complete education, I would allow no pupil to graduate from a high school who was not as proficient and exact in mechanical as in grammatical exercises; I would not make myself responsible for adding to the number of youth who have been trained in description, without having been taught to observe the things they should describe; who have spent years in the art of rhetorical elaboration and ornamentation, without acquiring any adequate body and substance upon which to exercise those arts; who are clever in dialectics and declamation, but purblind in perception and feeble in execution; great at second-hand knowledge, but confused and diffident when thrown upon their own resources; skillful with the pen, but using any other tool awkwardly and ignorantly. (12—201, 202)

Dr. Woodward spoke on "The Function of the Public School" and took occasion to reply to critics of manual training and to clear up obscurities of statement.

But the end of obstructing opposition had not yet come. It did come, however, during the next two years. At the meeting of the Department of Superintendence in Washington, February, 1888, Charles H. Ham of Chicago, author of the book, *Manual Training*, published in 1886, pointed out the shortcomings of the public schools and advocated the general introduction of manual training. In doing so, however, he overstated his case against the public schools and drew forth caustic criticisms of the claims for manual training from Superintendent A. P. Marble. At this juncture, Dr. Nicholas Murray Butler, president of the New York College for the Training of Teachers, entered the arena and won immediate approval of his scholarly and practical exposition of manual training. He saw no need for fighting each other with windmills.

We are not now discussing the philosophy of manual training. That day has passed. It has been incontestably established that the powers of thought, expression by delineation and construction, the judgment and the executive faculty, must be trained as well as the observation, the memory, and the power to learn. . . . If shopwork is used as a means of manual training, it is because of its disciplinary value, not because of its utility. It is only a means, not an end. It will be discarded whenever anything better adapted to accomplish the end in view is discovered, just as an old geography is thrown away when a better one is made. . . . That part of the training of the expressive faculties which is included in the terms "drawing" and "construction work" is what is meant nowadays by manual training. If the term manual training is used in antithesis to mental training, it is wrongly understood. Manual training, as I use the term, is mental training. It is mental training by means of manual training. It is included in the psychologically determined course of study because it reaches important mental faculties which no other studies reach. It is also a most valuable and important stimulus to the receptive faculty of observation. The child can neither draw accurately nor construct correctly unless he observes acutely. (10—II, 845, 846)

Continuing the discussion in harmony with the accepted psychology of that time, Dr. Butler's statements won wide approval among the many educational leaders who were present.

Plans had been laid for a still more complete discussion

of the subject at the meeting of the Department of Superintendence the following year, 1889. Again the Department met in Washington. There was a large attendance of leaders on both sides of the question, though two of the leaders favoring manual training were unable to be present. The result was that the outstanding contribution was a paper on "The Psychology of Manual Training" by Dr. William T. Harris. This was in such demand after the convention that it was printed in full several times. As one might expect from the founder of the *Journal of Speculative Philosophy*, it did not accept the teachings of Pestalozzi concerning the place of sense perception in education. It did, however, admit the possibility that manual training might be incorporated into the school system "as a general discipline," though Dr. Harris continued to believe that its place was in special schools for training apprentices. One of his chief points of attack was Dr. Woodward's phrase, "Put the whole boy to school." He connected that with what he said had become "fashionable in educational treatises since the days of Pestalozzi to define the province of education as the 'full and harmonious development of all our faculties.'" "This is," he said, "a survival of Rousseauism and, like all survivals from that source, is very dangerous." . . . "Again, this definition ignores the great distinction between the higher and lower faculties, between our faculties that are means to ends above them and those faculties which are ends in themselves. Sound psychology, for example, looks upon ethical insight as higher than insight into what is useful as a means to an end." (10—II, 907)

In fact, Dr. Harris's paper was more of an attack on the language used by the advocates of manual training in making their claims for it than on the manual-training work being done in the schools. The result of this paper was to stimulate more thoughtful discussion of the subject generally. An interesting fact in this connection is that, while Dr. Harris was afraid of "Rousseauism" and Pestalozzi's statements about "harmonious development," he was one of the chief American advocates of Froebel's kindergarten.

The final effort of the opposition forces to manual training in public education came at the convention of the National Education Association at Nashville, Tennessee, July 15, 1889. At that meeting, a Committee on Pedagogics, of which Dr. Harris was a member, made its report. From one standpoint, this report was a summary of the doubts and fears of schoolmen who did not fully comprehend what manual training was seeking to accomplish. They were blinded by the superficiality of their observations and by the overstatements of some of the enthusiastic advocates of manual training. The committee still clung to the idea that manual training was a good substitute for apprenticeship and that it should be confined to special schools, but only for boys who were twelve or preferably fifteen years of age. The report admitted that "manual training is an educative influence; for all that man does or experiences is educative to him, and affects both his will and his intellect"; but manual training, the report said, did not compare favorably with pure science, and history, language, and the other ordinary branches of school work. The report did, however, heartily approve industrial drawing as an elementary school subject; but in this subject, also, the report said, the purpose should not be the acquirement of a "new art of expression" but a means of "acquiring familiarity with the conventional forms of beauty in ornament." (10—II, 931 to 936).

At the same meeting, Dr. Harris read a paper on "The Intellectual Value of Tool Work." After a clear-cut, philosophical discussion of the subject from his point of view, he reached this conclusion:

Tool work without the theory of construction is educative to some extent, especially in the first stages of its practice. Tool work taught with the theory of machinery, with applied mathematics, is far more educative than mere tool work; and its educative influence lasts for a much longer time. Tool work with its theory and with natural science is permanently educative, and it does much to raise manual labor above drudgery; and especially is this the case if it is studied with the history of ornamentation and with careful cultivation of aesthetic taste.

But when compared with the present course of study in the schools it cannot be claimed that manual training opens any new windows of the soul,

although it may give a more distinct view from the window that opens towards inorganic nature.

There remains, notwithstanding, a permanently valid place for the manual-training school side by side with apprentice schools for all youths who are old enough to enter a trade, and who are unwilling to carry on any further their purely cultural studies. (10—II, 942)

The last phrase of this statement is especially revealing.

Concerning the heated discussion of this and other papers and the report of the Committee on Pedagogics, Dr. Woodward said, in his Chapter V on "The Rise and Progress of Manual Training," published in the Report of the Commissioner of Education for 1893-94, "Undoubtedly false issues were presented, wild assumptions were made, and much that was irrelevant was introduced; but the outcome, 'after the smoke and confusion of battle had cleared away,' was a clear conviction and a united purpose." In other words, he considered that the advocates of manual training had won. But the last word in this long controversy was spoken by Dr. Woodward himself. It was an extensive review of the report of the Committee on Pedagogics written for *The Teacher*, republished in pamphlet form, and later as Chapter XV in his book, *Manual Training in Education*. In this review, Dr. Woodward brought into more formidable array the claims of the leading supporters of manual training as an integral part of public education. He especially discussed (a) the curriculum of the manual-training school, (b) school tool work vs. trade work, (c) the age of manual-training school pupils, (d) social evils as related to manual training, (e) manual training compared with the study of pure science, (f) intellectual powers, mischievous, beneficial and otherwise, (g) the economic value of the method of manual training, (h) the argument against liberal culture in tool work, and (i) conclusion.

Under the last heading, Dr. Woodward quoted from the report of Superintendent James MacAlister concerning the public Philadelphia Manual Training School:

On account of its novelty, the manual training is apt to make the strongest impression upon visitors, and they do not always discover that the literary and scientific training are just as fully recognized and provided for. Anything

like a one-sided culture is carefully avoided, the aim of the school being to give each branch, whether scholastic or manual, such relative importance as shall lead to a fuller and more symmetrical development of mind and body than has been possible under the old systems of secondary education.

The success which has attended the manual-training school from the first is the best guarantee of the soundness of the principles upon which it is organized and conducted. Beginning a little more than four years ago, in a very humble way, it has steadily grown in public confidence and approval. It has more than justified every claim that was made in its behalf. (13—273, 274)

76. Variations from the Original Type of Manual-Training High School. As might be expected, on account of the immediate success of the St. Louis Manual Training School, other schools established during the next few years followed the original school very closely in curriculum and daily program. Later, however, experience, local conditions, and changing ideals brought about departures from the type set by the St. Louis School.

On February 4, 1884, in the City of Chicago, the second manual-training school was opened. This school, known as the Chicago Manual Training School, was founded by the Commercial Club of Chicago. At its regular club meeting, held March 25, 1882, the need of a school for industrial training in Chicago was discussed, more than half of \$100,000 pledged, and the necessary steps taken to secure a charter and a board of trustees for the school. Members of the club had visited the St. Louis School and were ready to accept its general plan for their own school. On September 24, 1883, the cornerstone was laid for a fine building, to be erected on the corner of Twelfth Street and Michigan Avenue. This building served the school's needs for many years, until the school became a part of the University of Chicago High School. Fig. 119 (10—IV, 70) A very important action for the future development of the school was the selection of Henry H. Belfield as director of the school. He was at that time principal of the North Division High School, Chicago. Eleven years before that time, which was previous to the Centennial Exposition of 1876, Dr. Belfield had urged the need of industrial training in the public school of Chicago in which he was a teacher. His plea was met with derision.

Both by conviction and experience, therefore, he was well qualified to guide the work of the new school. (14—342)

On March 3, 1884, the first manual-training high school to be supported at public expense, as part of a public-school

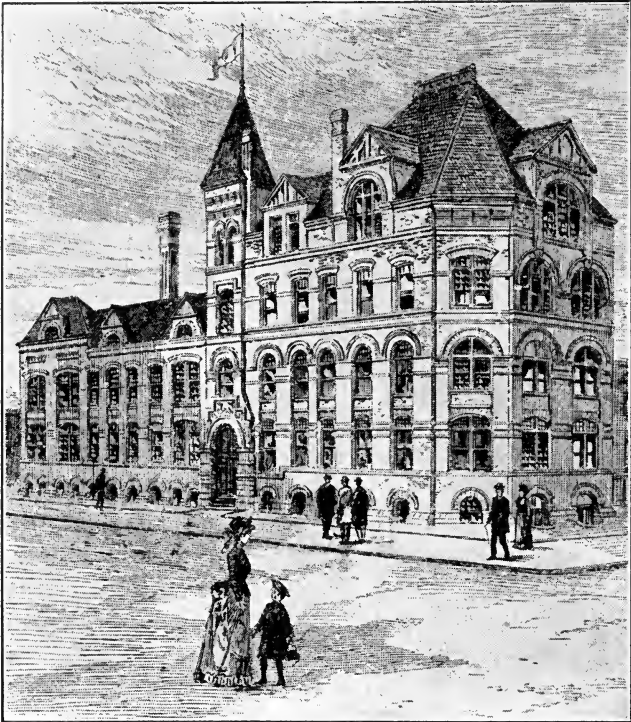

FIG. 119. CHICAGO MANUAL TRAINING SCHOOL

system, was opened in the City of Baltimore. In the previous October, the City Council had approved the plan recommended by the Board of School Commissioners. The school was modeled after the one in St. Louis. Dr. Richard M. Grady, principal of the school, had made a study of the St. Louis School, and Dr. Woodward had made an address at Johns Hopkins University in Baltimore to arouse public interest in the new school. (10—II, 357) In his efforts to organize the manual-training school, Dr. Grady was greatly encouraged by President Daniel C. Gilman of Johns Hopkins University. (7—890)

The Philadelphia Manual Training School, the second high school of this type to be supported at public expense as part of the public-school system, was opened in September, 1885, with Lieutenant Robert Crawford of the United States Navy as director, and William L. Sayre as principal. Lieutenant Crawford had been serving as superintendent of the mechanical department of the Spring Garden Institute in Philadelphia, and Mr. Sayre had been principal of a grammar school in that city. Their titles were afterwards changed to principal and vice-principal. When, in 1887, Lieutenant Crawford was ordered to active duty in the Navy, Mr. Sayre became the principal of the school. (15—179, 180) This school was brought into being on account of one of the first recommendations of James MacAlister, who went from Milwaukee to Philadelphia to become the superintendent of public schools there in 1883.

The regulations for this school called for a five-hour day—two hours for “study and recitation,” one hour for drawing, two hours for shopwork, and a half-hour recess—but, as actually organized, it had three two-hour periods—one for literary subjects, one for drawing and mathematics, and one for shopwork. There was a half-hour recess for lunch between the second and third periods. This kept the school quite close to the original St. Louis type.

A distinctive feature of the Philadelphia School, however, was the fact that in the shopwork woodworking and metalworking were given in parallel courses. For example, during the first year, pupils followed a course in joinery, and parallel with it a course in metalwork, including chipping, filing, fitting, molding, and casting. In the second year, tinsmithing and forging ran parallel to patternmaking. The daily program called for both woodwork and metalwork in the shopwork period. As the original outline did not include this new course feature, it is believed to have originated as a physical necessity in making a time schedule during the first year of the school, and proved so satisfactory that it was continued. Figs. 120, 121, and 122 reveal the fact that the

shop courses were decidedly disciplinary in character, requiring only a few kinds and sizes of material, arranged with easy steps in progressing from a given exercise to the next one, and consequently well adapted to class methods of instruction. It is noticeable that so early in the history of the manual-training school tinsmithing was included among the shop courses.

On the 5th of December, 1885, the building of the Toledo Manual Training School was opened to students of the adjoining high and grammar school. The eventful history of this school goes back to 1872, when Jesup W. Scott and his wife gave 160 acres of land to found "Toledo University of Arts and Trades." After Mr. Scott's death, his widow and three sons added materially to this gift; but up to 1884, the funds of the University were not sufficient to carry out its original purpose, and the property of the University was turned over to the City of Toledo to be administered by a board of directors. It was then decided that the first department of the University to be established should be a manual-training school. For this purpose an addition to the high school was built and equipped after the plan of the St. Louis Manual Training School. A graduate of the St. Louis school, Ralph H. Miller, was the first instructor in shopwork and was designated as principal of the Manual Training School. The academic subjects were taught in the high-school building. (10—II, 405 to 407) While this school was not independent of the general high school, its manual-training equipment was complete and its course of instruction was similar to that of the typical manual-training high school.

In this school, two important variations from the original type were made: A four-year course, beginning with the upper grammar grade, was adopted, and for the first time this type of school provided for girls as well as boys. Advice concerning the manual work for girls was received from Emma P. Ewing, dean of the School of Domestic Economy in Iowa State College.

The shopwork for boys, by years, was outlined as follows:

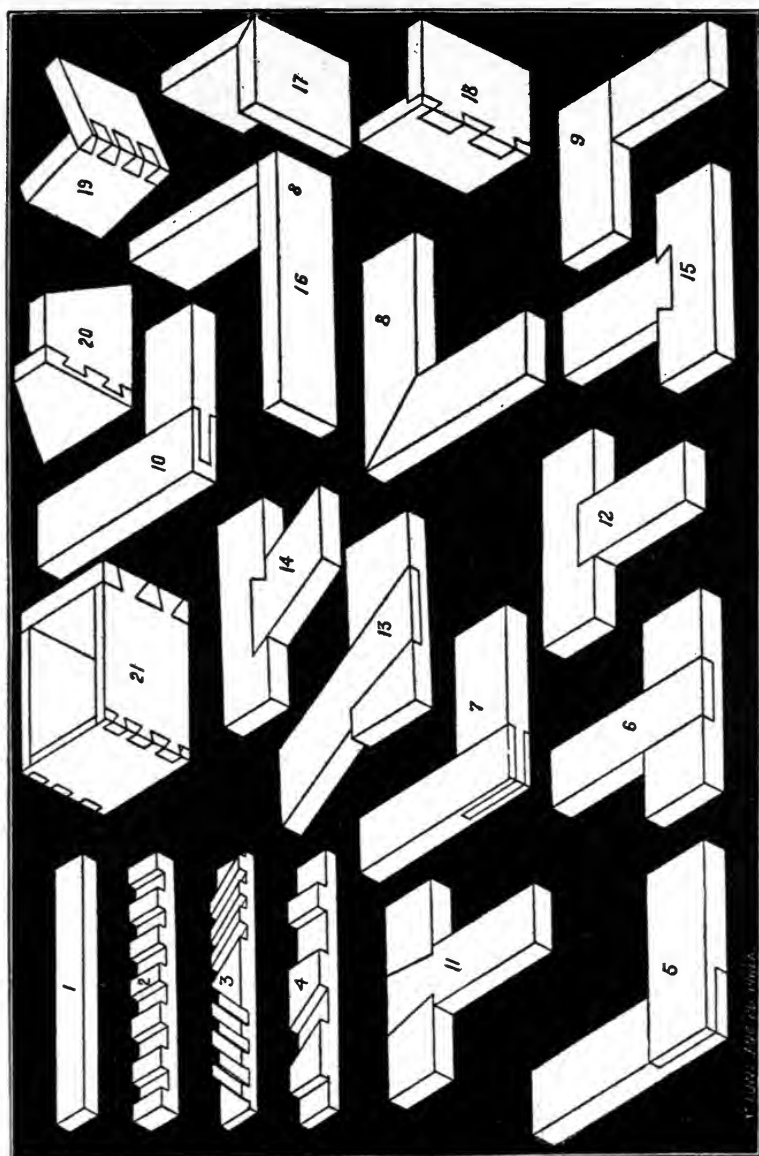
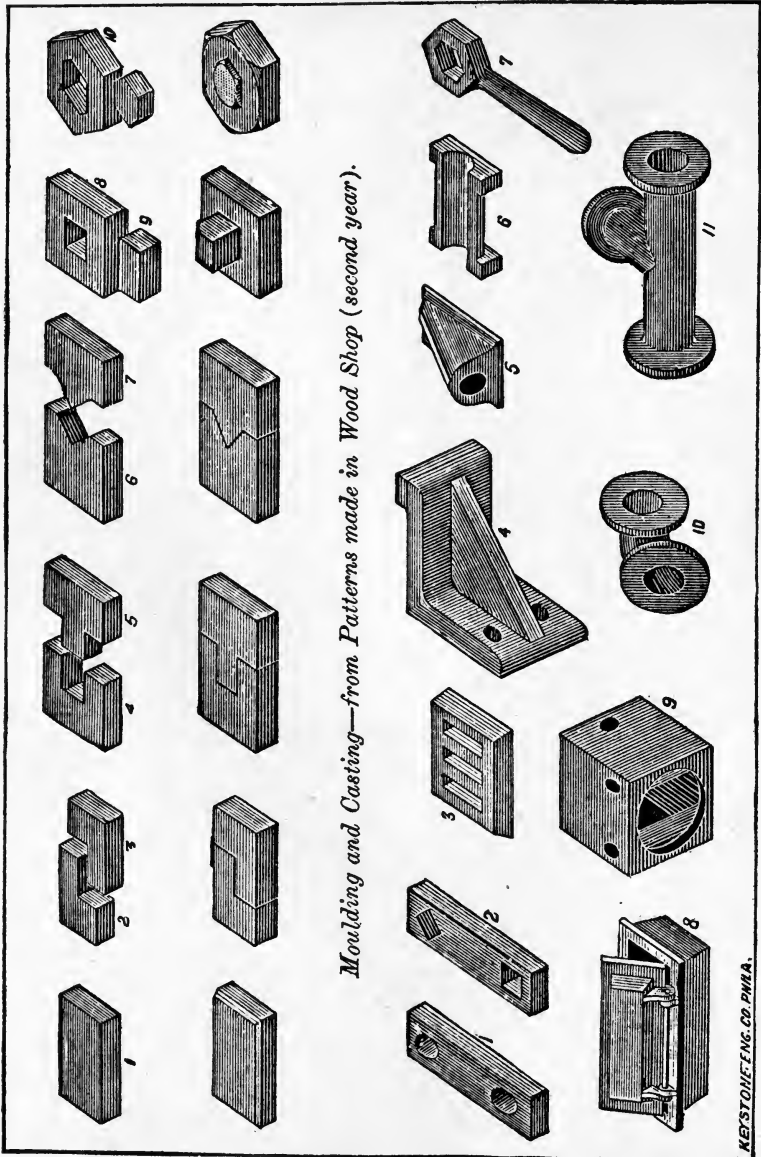

FIG. 120. JOINERY COURSE, PHILADELPHIA MANUAL TRAINING SCHOOL

W. L. B. 1907



Moulding and Casting—from Patterns made in Wood Shop (second year).

FIG. 121. CHIPPING AND FILING COURSE, ALSO PATTERNMAKING COURSE, PHILADELPHIA

KEystone ENG. CO. PHILA.

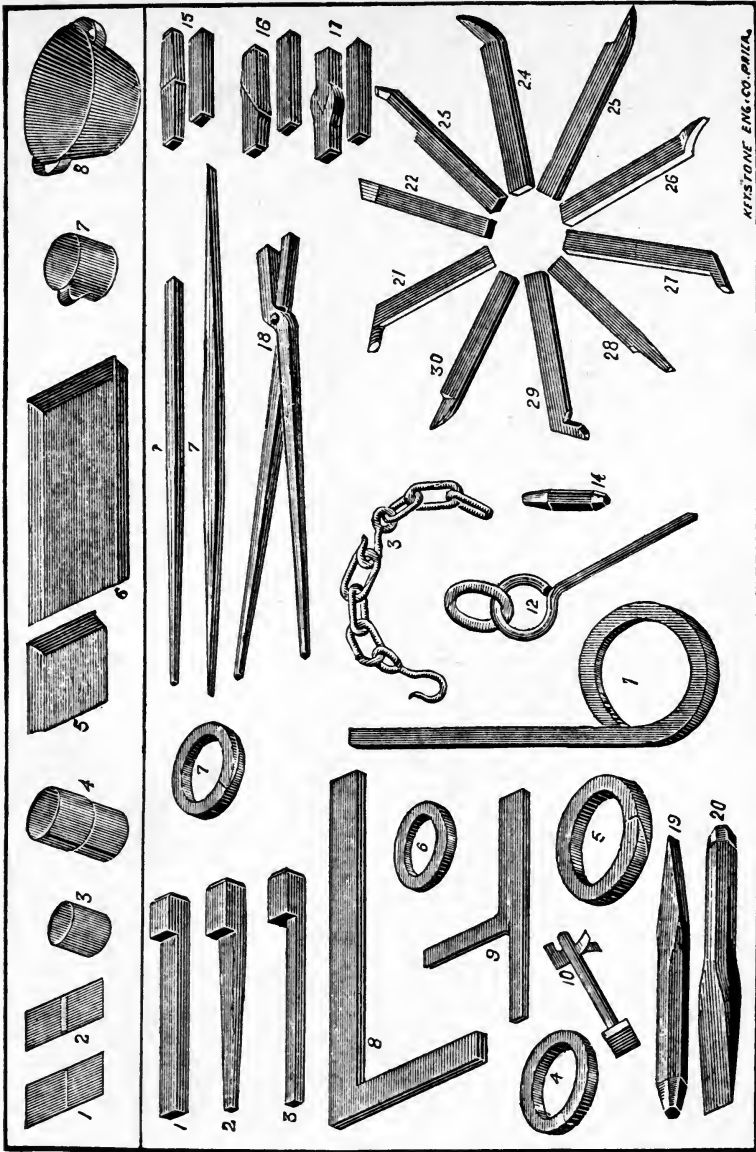

FIG. 122. TINSMITHING AND FORGING COURSES, PHILADELPHIA MANUAL TRAINING SCHOOL

1. Carpentry, joinery, jig sawing, proper care and use of tools.
2. Wood turning, patternmaking, wood carving, clay modeling.
3. Forging, welding, tempering, brazing and soldering, molding and casting.
4. Chipping, filing, turning, drilling, planing, etc. Study of machinery, care of steam engine and boilers, study of electrical machinery and gas engines. (10—II, 416)

The "domestic economy" for girls was outlined in this way:

1. Light carpentry, wood carving, care and use of tools.
2. Clay modeling, wood turning, introduction to course in cooking, or garment cutting and making.
3. Instruction in preparing and cooking food, purchasing household supplies, care of the sick, etc.
4. Cutting, making, and fitting of garments; household decorations, typewriting, etc. (10—II, 418, 419)

Parallel with the shop and domestic-economy courses were courses in drawing.

In much the same way that the Chicago Manual Training School came into being, a school of the same type was organized in Cincinnati, but it was known as The Technical School of Cincinnati. It was opened to students in November, 1886. An association was formed and incorporated to manage the school, which occupied one wing of Music Hall. After the first year, about half of the funds needed for running the school were supplied by the Commercial Club of Cincinnati. The principal of this school was E. R. Booth, who came from the St. Louis School, where he taught academic subjects. The course covered four years. Considerable emphasis was given to the fact that graduates of the school were admitted to several of the leading engineering schools without examination. (4—246). In 1901, the school was taken over by the University of Cincinnati and moved to the University campus, where a suitable building was erected for its use.

The Manual Training School at St. Paul, Minnesota, opened in September, 1888, under the principalship of Charles A. Bennett, a graduate of the Worcester Polytechnic Institute; though manual training for students of the high school who wished to elect it was begun in the fall of 1887. The manual-training school at first was in the high-school building, though independent of the high school in administration. (4—164)

to 172) The course was of three years' duration and was modeled after that of the St. Louis Manual Training School, though modified somewhat to meet the needs of pupils of the eighth, ninth, and tenth grades. While keeping rather close to the original type, this school was at the same time making



FIG. 123. ST. PAUL MANUAL TRAINING SCHOOL

the eighth-grade instruction very practical in order to hold more boys for high-school work. This school, therefore, was one of the early efforts to reach grammar-grade boys which, years later, culminated in the junior high school. In this school, also, some progress was made toward flexibility in the organization of shop and drawing courses to meet the needs of pupils of varying interests and abilities. This led to the introduction of completed useful problems and projects after a few fundamental tool exercises. In May, 1889, the contract was let for a new \$70,000 building for the school. Fig. 123. In the following February, it was ready for occupancy. A few years later, under the supervision of Eli Pickwick, Jr., manual-training shops were provided in grammar-school buildings and the manual-training school, under the principalship of George Weitbrecht, became the Mechanic Arts High School with four years of work above the eighth grade.

This type of high school had now become well established in the minds of schoolmen and it had met with the hearty approval of the public in many places. It had demonstrated that many boys were more attracted to it than to the older type of high school and would therefore remain in school longer on account of it; that boys completing the course in a manual-training high school were better prepared for a variety of industrial occupations than the graduate of the regular high school. While the schoolmen were wrangling over foolish claims both for and against this new type of school, many manufacturers, merchants, and critics were hearty in its approval. In several notable cases, they were so much in favor of it that they were willing to provide funds to establish schools of this type. They looked upon the manual-training school as the solution of what they regarded as one of America's greatest problems. They believed that this new type of school was to solve the problem of providing more skilled labor.

Beginning with Dr. Woodward's school in St. Louis, donors came forward with large sums. As already mentioned, the first schools in Chicago, Toledo, and Cincinnati were established in this way. There followed in 1886 the Manual Training School of Tulane University, in New Orleans, under the directorship of Professor John M. Ordway, who came from the Massachusetts Institute of Technology; in 1887, Pratt Institute was established in Brooklyn, New York; in 1888 Frederick H. Rindge gave the City of Cambridge, Massachusetts, a building for a manual-training school; in 1891, Senator Stout began his series of gifts to Menomonie, Wisconsin, for a manual-training school; in 1892, the Dupont gift was made to Louisville, Kentucky; and, in 1896, the Hackley Manual Training School opened in Muskegon, Michigan.

While this is by no means a complete list of such gifts and while, in some cases, the gifts were made to establish schools which were to be maintained at public expense, it is sufficient as indicating the vital quality of the interest of public-spirited men in the manual-training high school as a means of providing a more practical education, especially for boys. To some of these schools, girls also were admitted.

As this type of school grew in popularity, there was a constant tendency to enrich the course of instruction so as to serve a larger number of pupils. This meant a wider range of courses, more elective subjects, and a school day of more than six periods. An extreme example of this tendency was the Industrial Training School (later the Manual Training High School) of Indianapolis, of which Charles E. Emmerich was principal. In this school, the elective system was carried so far that students whose schooling was expected to end with the high school were allowed, after the first half year, to select any studies offered "in the order in which they are presented, with the exception of English, which was required for three years, and algebra, which was required for one year." A student receiving thirty-one credits was given the diploma of the school. This plan was not so free from restrictions as at first appears because "suggestions," very specific and subject to positive regulations, were given to students. If a student wished to enter an engineering college, a course was open to him with but one elective credit in the four years. If he wished to pursue a classical or scientific course in college, only three elective credits were open to him. If a student was intending to enter the Normal Training School of the city, he was "earnestly advised" to follow a certain course of electives. This scheme, under strong administration, made it possible to develop special talent to an unusual degree and provide for some students a rather highly specialized training for a vocation. Such a school must necessarily have more than six periods a day to carry out its plan; therefore, an eight-period day was adopted beginning at 8:45 and closing at 4:15. This school was outstanding, not only on account of its elective system, but also on account of its strong practical courses for girls as well as for boys—courses in art, cookery, sewing, shorthand, and typewriting. (16—15)

This tendency to enrich the manual-training high-school course brought about important changes in two directions: (1) toward a complete fusion with the regular or academic high school, which ultimately resulted in what came to be

known as the cosmopolitan or comprehensive high school; and (2) toward a richer curriculum on the technical side, resulting in what was called a technical high school or, in a few cases, a mechanic-arts high school, a manual-arts high school, or a polytechnic high school, though the latter two terms were sometimes applied, as in California, to schools of the comprehensive type. The technical high school, theoretically at least, is a more specialized school of the manual-training high-school type. It belongs, therefore, only in a city that has more than one high school.

Of this second type, the Technical High School at Springfield, Massachusetts, under the principalship of Charles F. Warner, may be taken as an early example. This school was established as a separate high school in September, 1898, and was designated "Mechanic Arts High School." Its program and plan were modeled after that of the Mechanic Arts High School of Boston and, going a little further back, after that of the Rindge Manual Training School of Cambridge, because the first headmaster of the Boston School, Frank A. Hill, later secretary of the Massachusetts Board of Education, came from the headmastership of the English High School of Cambridge, where he worked in cooperation with Harry Ellis in the organization of the Rindge school.

The purpose of the Springfield school was not understood at first, partly because it was associated in the minds of many people with its predecessor in the same building—the Industrial Institute—which had been a private school for teaching trades, both day and night; partly because, in October, 1898, soon after the opening of the Mechanic Arts High School, a new public evening trade school was organized in the same building, making use of the same equipment and employing the same teachers as the high school;¹ and partly because the word, "Mechanic," in the name of the school was misinterpreted by many to imply the teaching of trades. The Mechanic Arts High School was not organized as a trade school, but as a high school in which, besides the academic branches of a full high-school course, the fundamental principles of drawing, of design, and of hand and machine tool work should be taught in a practical way. In order that there might be no further misunderstanding of the purposes of the school, its name was changed in 1904 to the Technical High School. . . . It bears to the older high school a relation similar to that which schools of technology of college grade bear to colleges of

¹This evening trade school is said to be the first school in the United States to offer trade training at public expense.

the liberal arts. . . . Pupils may be prepared for college in this school. . . . No attempt is made to teach the trades. In the same spirit, courses in domestic science and household arts are offered to girls. The educational aim is broad and practical, not narrowly vocational.²

The term "technical high school" became an increasingly popular term to designate the highly specialized schools in which shopwork, drawing, and science as applied in industry were prominent in the curriculums. On the other hand, the comprehensive high schools giving a prominent place to shopwork and drawing were given less descriptive names, as the McKinley, the Yeatman, and the Cleveland high schools in St. Louis, or the Woodward and the Hughes high schools in Cincinnati.

Another and later example of the tendency to introduce a more extended program of technical subjects is found in the Stuyvesant High School in New York City, which opened in 1904 with Dr. Frank Rollins as principal. This school offered two courses: (1) A four-year preparatory course for colleges and professional schools, which was essentially of the manual-training high-school type, but with six instead of ten periods a week in shopwork; (2) an industrial course without foreign language, with the full ten periods a week in shopwork for three years, as in the original manual-training school, and then a fourth year in which the student was given an opportunity to spend ten periods a week in any one of the following highly technical subjects: (a) building construction (carpentry, sanitation, including heating and ventilation, electrical wiring and installation), (b) advanced forging and toolmaking, (c) advanced patternmaking and foundry practice, (d) advanced machine-shop practice, or (e) industrial chemistry. In this same year, there was an option between mechanical and architectural drawing, and an opportunity, in another four-hour course, to choose between advanced chemistry, economics, industrial and commercial law, or applied mechanics, steam, and electricity. (17—11)

²This quotation from the Springfield school report of 1906 and the facts in the previous paragraph are taken from a letter by Burton A. Adams, supervisor of manual arts in the schools of Springfield, sent to the author on September 27, 1932.

Almost immediately after the publication of the report of the Massachusetts Commission on Industrial and Technical Education, in 1906, (cf. 93) which demanded more "manual skill" and "industrial intelligence" as requisite to success in industrial occupation, and recommended "new elective industrial courses in high schools," the courses in many technical high schools began to be more vocational in character. The pendulum began to swing back to more nearly its original position in expressing the purpose of this type of high school. Many leaders in educational thinking had reached the conclusion that perhaps the industrialists were right and that no harm would come to general education if specific training for a vocation were given at public expense. While some still insisted that such training should be given in independent schools, others contended that it should be given as part of the public-school offering and so preserve the unity of the system of public education.

The new technical high schools as they came along gave special consideration to this newer point of view and shaped their courses accordingly. The Technical High School which opened in Cleveland, Ohio, in October, 1908, under the principalship of James F. Barker, allowed a student to elect to work in any shop after the first third of the third year. During the fourth year, a student might elect to spend twenty periods a week in some one line of technical work. In this school, there were eight 45-minute periods a day—40 periods a week. (18—18)

In the same year, 1908, The Lane Technical High School, Chicago, under the principalship of William J. Bogan, was established in its new building with a liberal attitude toward technical electives. In 1910, the Board of Education authorized "two-year vocational courses" in the high schools of Chicago, and such a course in electricity was organized at the Lane Technical High School. This course included instruction in science, mathematics, English, drawing, civics, and ten hours a week in applied electricity during the second year. (19—162)

In 1912, the William L. Dickinson High School, Jersey

City, New Jersey, opened an industrial department under the direction of Frank L. Mathewson, who came from the Technical High School in Cleveland. This department is probably the best example of the extreme limit of the swing of the manual-training high school toward vocational training. While the Dickinson High School was not a typical technical high school, its industrial department, with the support of the academic department, was essentially that. The aim of the school as a whole was to provide "instruction for both boys and girls in three distinct departments: academic, commercial, and industrial." (20—5) The purpose of the industrial department was stated thus:

The aim of the courses in the technical and industrial department of the Wm. L. Dickinson High School is to prepare boys and girls for definite vocations and for efficient industrial citizenship, thus extending to them the opportunity for specialization during the period of secondary education. Its courses offer preparation for industrial efficiency to young people who never find beyond the grammar or high school an opportunity to fit themselves for a specific occupation and service.

The specialized industrial courses are intended to be strictly vocational, and it is assumed that pupils who may elect any of these courses have a fairly definite idea in regard to the particular vocation they wish to select and for which training is offered. The courses of instruction are planned to qualify those who complete them for positions in industrial work of similar character.

Academic studies for industrial pupils coordinate wherever possible with the various phases of the special kinds of shopwork, and at the same time aim to give a thorough understanding of the fundamental requirements of each academic subject. Problems in both mathematics and science are taken from the shops and drawing rooms and discussed in the classrooms. The shops also offer many themes for descriptive composition for classes in English. (20—7, 8)

During the first two years, all boys pursued a definitely prescribed group of studies about equally divided between shopwork, drawing, and academic subjects (English, mathematics, and science, or history). During the last two years, students were given an opportunity to specialize in machine design, architectural drawing, machine-shop practice, carpentry, cabinetmaking, patternmaking, printing, or foundry practice. The courses for girls were worked out on the same principles. (20—8 to 16)

The Cass Technical High School of Detroit, Michigan, was

another school that placed emphasis on vocational instruction without becoming a trade school. A few facts concerning its history reveal the spirit and motive of the school. As early as 1900, Benjamin F. Comfort, a Detroit teacher of mathematics with several years of industrial experience, revealed to the superintendent of schools that he had a burning ambition to organize a high school to meet the practical needs of the 90 per cent of the pupils who entered the high schools of Detroit but did not go to college. In 1906, the desired opportunity came to him. In February, 1907, with 110 pupils and a small equipment on the third floor and in the basement of the Cass Primary School building, he began to solve his problem. His constant aim was to adapt the instruction to the needs of Detroit's rapidly growing industries, and in that way to the needs of the boys and girls who were to be employed in these industries.

For five years, from 1912 to 1917, the school sent three of its experienced teachers every day into the industries of the city to learn just what courses were wanted. These men spent their forenoons in the industries and their afternoons and evenings in teaching and in helping to develop in the school such practical courses as they found were wanted. The continued operation of this plan, together with new buildings, a growing faculty of specialists, and adequate financial support, resulted in the rapid development of a strong technical high school. Moreover, the continuance of the policy of first finding out what courses were wanted and then offering them led out into a wider and still wider field of educational endeavor. The school thus became the mother of three other schools: From 1909 to 1918, there was developing in the Cass School a high school of commerce. In 1914, a part-time continuation school began, which was nurtured until it became too large to care for in 1922. In 1914, also, a class of drug clerks needed instruction in chemistry, and out of this class grew a high-school course in pharmacy, which later became a college of pharmacy.

These statements account for the fact that the total enrollment in this mother school has sometimes been very

large—more than 16,000, counting day and evening pupils.³

77. **Manual Training in General High Schools.** As soon as the success of the St. Louis Manual Training School was evident, the general high schools in many places began to introduce shopwork courses—especially woodworking. In many cases, these were accompanied by work in mechanical drawing. The records seem to indicate that the first public high school to take such action was the one at Peru, Illinois, a small industrial city of 6,500 inhabitants. "In January, 1884, Joseph Carter, then superintendent of schools, upon his own responsibility, and with his own money, purchased twenty sets of carpentry tools and workbenches, and fitted up the basement of one of the school buildings as a workshop." To these he added other necessary tools for general use.

This action aroused much criticism, but Mr. Carter was upheld by the school board, and the results gradually disarmed the opposition. At first the shopwork was taught by a carpenter, but later one of the high-school teachers with a fair knowledge of tool work gave the instruction. This was considered a more satisfactory plan. Three years after the work started, the aims in the manual training were stated thus:

1. To inculcate a correct knowledge of the use and care of woodworking tools.
 2. To implant the habit of carefulness in accomplishing work.
 3. To develop the power to plan work.
 4. To teach quickness of perception; to train the judgment; to render the memory exact and reliable.
 5. To turn the pent-up energies of the boy into channels of usefulness.
- (10—II, 192)

In the year 1884, manual training was introduced in the high school of Eau Claire, Wisconsin, an industrial center of about 20,000 population. The work was so successful the first year that the course was extended and, in 1887, three years of work was given—two in woodwork and one in forging iron. The forty boys in the manual-training work were divided into four classes of ten each. The boys were allowed to work on

³The facts concerning the Cass Technical High School were, for the most part, gleaned from manuscripts loaned by the principal of the school.

Saturdays. Then, as a school official naïvely stated, they did "piecework; that is, doing little jobs or in making something." The boys taking manual training were said to "make more rapid progress and do much better work in all branches of mathematics" than boys of the same age who were not taking manual training. (10—II, 204)

In the month of February, 1885, under the leadership of Newton M. Anderson, a teacher of physics in the Central High School of Cleveland, Ohio, a small carpenter shop was provided in a barn to teach manual training to a group of high-school boys after school hours. This shop and the enthusiasm of the boys attracted the attention of some of the business men of the city, who formed a stock company. The Cleveland Manual Training School Company was therefore incorporated June 2, 1885, for the purpose of establishing and maintaining a manual-training school. A building was erected and equipped and the school opened in February, 1886, with Mr. Anderson as principal.

A tuition of \$40 a year was charged. This tuition fee prevented many desirable boys from entering the school, and the Board of Education petitioned the State Legislature for authority to levy a tax of two tenths of a mill annually to establish and maintain "manual- and domestic-training schools" in the city. The authority was granted and the Board of Education took over the maintenance of the school so that tuition was free to all public-school boys who had passed into the high school and to certain others over fourteen years of age. The course of instruction was announced thus:

First Year.—Freehand and mechanical drawing; carpentry and joinery; patternmaking; care and use of tools.

Second Year.—Geometrical and mechanical drawing; forging, welding, tempering, filing and chipping.

Third Year.—Machine and architectural drawing; machine-shop work; study of machines, steam engines and boilers. (10—II, 438, 439)

The announcement of this school published in 1887 contained the following details, which may be considered as representing the best practice of that time—an American modification of the Russian System:

The pupils all pass through the same course, which is progressively arranged, so that each department may be considered a preparation for the next. The pupil begins with the simplest tools and work, and passes by degrees to the more complex and difficult. . . .

At the outset the boy is placed in the carpenter shop, a room 56 by 35 feet, in which are twenty-three carpenter's benches, so arranged that each pupil has plenty of light and space. The benches are equipped with vises, stops, and tool racks. Upon the tool racks of each bench are a rip saw, cross-cut saw, back saw, hammer, mallet, large steel square, try square, bevel gauge, mortising gauge, foot rule, dividers, hand screw, screw driver, awl and chalk line, oilstone, and oil can. These tools belong to the bench, and are used by the one working thereat. The lower part of the bench is divided into three compartments, each of which contains a set of edge tools, consisting of jack plane, smooth plane, block plane, and set of chisels. *All tools are of the best quality.* The classes are divided into three divisions, working at different times. One of the compartments is assigned to each pupil. Each compartment is provided with lock and key, and the tools in it are considered the property of the pupil using it during the term he is at work in that shop. He is responsible for the tools and their condition. The pupils are taught to grind their own tools. The instructor's bench is so placed as to allow space for the class to assemble in front of it. Here the instructor calls the class together, explains the construction and use of each tool and the methods of laying out work, and instructs them in regard to the selection of wood, its shrinking, warping, and checking.

During the time the boys are at work at the benches, the instructor goes from one to the other, giving them personal instruction. At first the boys are taught the use of the crosscut and rip saws. With chalk line and square, they mark off strips and then saw them, until they can use the saw fairly well, after which they use the jack plane, and then the smoothing plane. The first piece the pupil is required to make is a block of given dimensions, *which must be perfectly flat on each face with all the angles right angles.* This board is used in making a bench hook. Working drawings of each piece are made for the pupils to work from. The second piece of the course is a box 8 by 6 by 4 inches.

After completing the box in a manner satisfactory to the instructor, the pupil makes a square miter joint. This piece is laid out with square and bevel gauge and made with saw and plane without using a miter box. Then follow halved joints, open and closed mortise-and-tenon, open and blind dowel pin, dovetail and glue joints, and panel making.

In all of these exercises, great care is used to impress upon the minds of the pupils the necessity of accuracy in their work. Each piece is marked by the instructor in the presence of the pupil. In the marking, the greatest value is given to dimensions, then joints and angles, and then finish. (10—II, 440, 441)

In addition to the regular exercise pieces mentioned above, during the year 1886, the boys made book shelves, screen doors, center tables, hat racks, milk stools, footstools, easels,

Indian clubs, ball bats, picture frames, and a cabinet. (4—261)

Each class had three lessons a week. Each lesson was three hours in length. Six hours of this time were spent in shopwork and three in drawing. (4—260)

In 1890, the Board of Education established the West Manual Training School under the principalship of William E. Roberts, who came from Boston, where he had been an instructor in the School of Mechanic Arts of the Massachusetts Institute of Technology. An abandoned high-school building was used for this new school. Nothing but shopwork and drawing were taught in it. Boys came from the high schools of the city after the regular high-school hours. Included in the three-year course were bench woodworking, wood turning, patternmaking, forging, machine-shop work, clay modeling and plaster work. A fourth year of work was given to some boys as a special privilege.

Among the first cities to give manual training a place in its public high school was Omaha, Nebraska. Beginning on the first of October, 1885, classes from the high school and the eighth grade were taught woodworking by A. Baumann, a graduate of the St. Louis Manual Training School. Bench and tool equipment was provided for twenty pupils in a class. Four classes were admitted. Each class was given an hour and a half of instruction every day. By the beginning of the second year, twenty wood-turning lathes with turning tools and an engine and boiler for power had been provided. (10—II, 430—432)

In January, 1887, the superintendent of schools said:

After an experiment of a little more than a year, it can be said that our venture has been a success. The progress of the boys has astonished us all. Without interfering with the academic work in the least, they have acquired more skill in the care and use of tools than apprentices are expected to have after a year or more of training in the usual way.

Although we have thus far made the work optional, and have expected from the shop boys the same amount of academic work as from the others, I am inclined to think it would be more satisfactory to make a special course for the manual training, and in this course reduce the academic work to some extent. In a large high school, this could be easily done, and while many will be willing to take the hour and a half spent daily in the shop from their recrea-

tion, it is doubtful if it is advisable to make it necessary in every case. (10—II, 429)

This statement reveals some of the immediate advantages of manual training and also some of the problems confronting the school principal and the superintendent of schools in their early efforts to make manual training an integral part of the public-school work. The manual-training group of studies in a general high school had not yet appeared.

The high school in the city of Washington, D. C., also was one of the very earliest to adopt manual training.⁴ In the school year, 1885-86, C. H. Koyl, teacher of physics, "succeeded in obtaining two cabinetmaker's benches, a circular saw, a wood-turning lathe, and an outfit of small tools, as equipment for a shop for which a small room in the basement was given to him." With this equipment, he gave his class in advanced physics one lesson a week in woodworking.

In September, 1886, Walter G. Wesson, a graduate of the Worcester Polytechnic Institute, was the first full-time instructor in manual training. A large room was provided and equipped with benches made the previous year by boys under the supervision of Mr. Koyl. A fact of some interest in this connection is that the one-lesson-a-week plan continued under Mr. Wesson. "Twenty-four classes of twelve boys each were given one lesson a week."

"In September, 1887, larger quarters, outside the school building, were acquired and equipped with twenty-four woodworking benches, six wood-turning lathes, six forges, and six molding benches." Mr. Wesson resigned, and John A. Chamberlain, also a graduate of the Worcester Polytechnic Institute, became the head of the manual-training work in Washington, a position which he held for more than forty years through many changes in the development of this department of school work. As early as 1888, a machine shop was added. That year, also, formal instruction in mechanical drawing was begun.

⁴The information concerning the beginnings of manual training in Washington are taken from a letter written to the author by John A. Chamberlain on March 29, 1929.

Another important city that began manual training by adding it as another subject to the general-high-school course was Minneapolis. In that city, however, instead of building an annex or a separate shop building, space for a shop was found in the central high-school building and, as new high schools were planned, shops were provided in each. Manual-training work began in Minneapolis in February, 1887, with W. F. Decker, previously a member of the faculty of the College of Mechanic Arts (Engineering) of the University of Minnesota, as instructor. It was given as part of an elective course, which included also drawing, arithmetic, and English for the first year. (10—II, 202, 203)

With very little reference to what had been done in Boston or St. Louis, Professor Decker proceeded to work out a course in woodworking for high schools which was probably the most genuinely American and the most thoroughly organized of any woodworking course of that period. In his method of presenting problems to students, he was years ahead of his time. Problems were presented to the pupils in the form of printed lesson sheets put up in pads $5\frac{1}{2}$ by $8\frac{1}{4}$ inches. One of the sheets is shown in Fig. 124. Professor Decker's own statement concerning the sheets was as follows:

Each of the sheets contains a working drawing of the product and additional sketches to illustrate principal operations, as well as printed directions for proceeding with the work.

Sheets are placed in the hands of each pupil at the bench, but additional instruction is given to assembled classes at the beginning of each exercise, when the instructor also shows how to properly use the tools. These lesson sheets are found to be almost indispensable as a means of systematizing the work and insuring thorough training in the fundamental operations. Our lessons begin with marking and sawing rough boards, and embrace all the principal steps of woodworking up to the construction of such useful articles as chests of drawers and ornamental cabinets.

Much attention is given to such operations as driving nails, planing to dimensions, boring, mortising, paring, etc. No construction is allowed that does not involve operations already learned. After completing the course laid down in the lesson sheets, the pupils take up wood carving and turning under a special instructor. (21—256)

From facts already stated, it is clear that there were two quite distinct ways of giving high-school pupils the benefit of instruction in manual training; namely, in the special manual-

EXERCISE XVIII

MAKING KEYED TENON JOINT.

Stock—Piece (1) of exercise six.

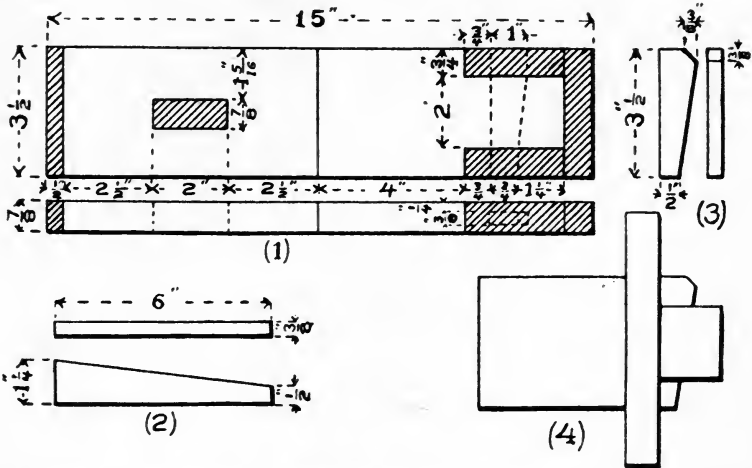

GENERAL DIRECTIONS—Mark as shown in (1).—Cut tenon and mortises.—Make oak key as shown in (2).—If work is approved, separate and block plane ends, join pieces and drive key.—Mark ends of key in line with edges of piece as indicated in (4).—Back out key, finish as shown in (3), and drive again.

The width of large mortise should be the same as thickness of piece, whatever that may be.—This is a very useful joint when the parts are liable to shrink.

FIG. 124. A PAGE FROM THE PRINTED COURSE IN WOODWORKING BY W. F. DECKER

training high school, as in Philadelphia, or in an elective course or in an elective group of studies in a general high school, as in Minneapolis. The fact that the manual training had been successful under both of these systems led, at times, to very warm discussions of the merits of each, especially for cities of considerable size. It was generally conceded that in a small town no such question arose because, without a very substantial private gift or even an endowment, a separate manual-training school would be financially out of the question. But, in the larger cities, where either system could be adopted, there was much discussion. On the one hand, there was the claim that only in a separate school would manual training be able to maintain its rightful place in the educational scheme; because most high-school principals did not appreciate the educative value of manual training, and because their decisions were influenced too largely by college entrance requirements. On the other hand, it was claimed that, if manual training was as valuable as its advocates claimed, it should be available to all high-school pupils. If its value is chiefly cultural, then it should be in the general high school; if chiefly occupational, then perhaps it should be in a separate school. The discussion led to a tangle of arguments, many of which on both sides were futile, and no generally accepted opinion was reached.

In a few cities, however, what may be regarded as a compromise, known as the cosmopolitan or comprehensive high school, was adopted. This plan brought into one school organization practically all of the courses and equipment that in other cities might be included in three schools—a general or a classical high school, a commercial high school, and a manual-training high school. It offered groups of studies in all three of these directions. The best examples of high schools of this type were in St. Louis and Cincinnati. In 1911, the courses in the Cincinnati high schools appeared under two general headings—academic and technical. Under academic, there were four courses: general, classical, domestic science, and manual training. These were for general culture and to prepare for colleges and professional schools. Under tech-

nical were four courses with a vocational emphasis. These were commercial, technical cooperative for boys, technical cooperative for girls, art, and music. In the art course, the instruction in art was given outside the high school in the Art Academy. Likewise, the practical work in the music course was given outside the school. During the last two years, the boys in the technical cooperative course spent half of their time in commercial shops and half in school. (22—2-3)

Thus, in a maximum degree, the comprehensive high school offered at once a breadth of opportunity for choice not possible in any specialized high school. Thus, also, it recognized the growing demand for courses leading more definitely toward a vocation.

In the ten years from 1883, when manual training first began to appear in public high schools, to 1893, under one of the plans described in this chapter, manual training was introduced into public high schools in more than fifty cities in the United States. (7—II, 2097-2113) By 1900, this number had more than doubled. (23—II, 2438-2440)

SOURCE MATERIAL X, A

THE TEACHER OF TOOL WORK

By Calvin M. Woodward

From *Art and Industry, Part IV*, by Isaac Edwards Clarke

Issued by the U. S. Bureau of Education, 1898

The proper functions of the shop teacher are little understood. He is not a historical character. Literature is not full of him; his sayings and doings are not on record; he is the latest product of evolution. Doubtless many of you have pictured him, in imagination, as a brawny fellow, with immense brown hands, with deft ways, an unerring eye, a fund of anecdote, abounding in ungrammatical figures of speech drawn from the bench, and cherishing undying admiration and reverence for the man he served under while learning his trade. You fancy him more fluent in directions than reasons; therefore, more ready to take one's tool and do one's exercise himself than to patiently explain and illustrate the method till his pupil can do it.

But you are in error. You are thinking of the experienced mechanic, not of the accomplished teacher. This new type of teacher is not a common article as yet. It is still a curiosity, and visitors to a school fortunate enough to have one spend most of their time watching him and his work. Let me give an account of him and present his picture.

This man has never served his time; that is, he has not spent from three to seven years earning his living while learning the mechanical processes and the business management of a single trade. His knowledge of applied mechanics differs from that of the ordinary workman as the mathematical training of a senior wrangler differs from the art of a lightning calculator. Under a variety of expert teachers, he has mastered the principles and become familiar with many crafts; he has studied a wide range of tools and materials, and is equally at home at every bench. . . .

In the first place, he believes it is his chief function *to teach*. His pupils are not to be left to find out for themselves how the various tools are to be used, how they are to be kept in order, and how a certain model is to be produced. He would no more leave them to thus teach themselves than you would give pupils pen, ink, and paper and leave them to learn penmanship by themselves; or than I would give an ignorant sailor a sextant and leave him to find out how to determine a ship's latitude and longitude by constantly trying. Tools are not what they are through accident or caprice; they are the product of ages of thought and experience, and there are best ways of using them. There is teachable art in handling the chisel, the gauge, and the file as there is in using a table fork, a tennis racket, and a drawing pen.

Moreover, as he has a score or more pupils to teach, he teaches them as a class and not individually: this enables him to make his instruction much more systematic and full, and it leaves him time to observe whether his instructions are followed. The class lecture is, therefore, almost a daily feature in his shop. It may occupy thirty minutes or only ten; but, while it lasts, it must absorb the attention of every pupil. He must have facilities for seating his class around his bench, anvil, or machine tool; so that they may be quiet and attentive and have good opportunity to see as well as to hear. His

room must be noiseless, and he must have at hand tools, materials, drawings, and blackboards. It is not a lecture properly so-called; for, as a rule, he does not read to his class; he talks, explains, and illustrates. He suits the action to the word, and the word to the action. This is an important point; for, like every other teacher in the school, he is a language teacher. When the need of a new word is clearly seen he gives it to his pupils, writes it before them; and henceforth it is a part of their vocabulary. He knows just where the class stands, how much and how little they know of the work in hand, and he discreetly leads them on a step at a time, and a step they never need retrace. He teaches the theory of every tool, and how it is to be put in order and kept so; he shows just how it is to be used and when; he analyzes a complicated operation into a series of simple steps, and points out the logic of his arrangement; he warns of peculiar difficulties and dangers; he leads his pupils to see that drawings may represent not only the details of form, but order of construction. Gradually he helps his pupils to build up a love for system, precision, and plan.

When his class instruction is over—and he is careful not to confuse and mislead by telling too much; he never tells all he knows—the pupils go to their separate places and reduce to genuine practice what to them is still only theory. The work of the class is as uniform as that of a class in algebra engaged on the solution of the same problem, or in chemistry when the pupils are performing the same experiment. A glance is sufficient to enable our teacher to detect a wrong motion or a false step, and he supplements his general instructions by such individual directions and explanations as may be necessary. He thus economizes time, and no pupil waits for him to come round. All have been taught; all have had opportunity for the same personal experience. If a pupil is inattentive or dull—and you may know that sometimes happens even in other studies—he patiently repeats what he has already said and done, or sends the dullard to a brighter pupil for direction and light; but he would no more take one's tools and do his work for him as the ordinary mechanic is generally too apt to do, having an eye more to the finished exercise than to the development of the child, than the teacher of English would write his pupil's composition, or the teacher of penmanship would fill out his pupil's copybook, or the teacher of drawing would finish his pupil's sketches. Success lies not in having certain things done, but in getting one's pupils to do them as well as they can.

When our teacher has examined and graded the pupil's work, he does not throw all the poor pieces into the waste box; but he shows a pupil the manifest defects of his workmanship, carefully preserves the specimen, no matter how poor, and encourages the pupil to replace it by a better one, made during such spare time as he may secure by getting other work in before "time is up." This encourages and rewards care and attention to business. There is no waste time in his shop. The rapid workers, who have no need to repeat their exercises, are always furnished with "extras" (corollaries to the main proposition) which fill their time, tax their ingenuity, and fire their ambition.

The discipline of the shop is such as promotes industry and fidelity. The standard of behavior is not that of the recitation-room, it is rather like that of the chemical laboratory. Necessary communication is allowed, but all trifling and distractions are strictly prohibited.

While in the shop, our teacher dresses as he expects his pupils to dress—appropriately. He sets no bad example; his language is correct and pure; his manners are those of a gentleman. The atmosphere of his shop is that of a science laboratory. His pupils soon become zealous and enthusiastic; there is no sense of drudgery, and no sordid motive impels to work. The pupils are as innocent of definite plans for utilizing the knowledge and skill they are acquiring (beyond the making of a toy, a present for a friend, or a convenience for his home) as they are in their arithmetic and history. The consciousness of growing power, both mental and manual, gives a satisfaction which throws a charm over every department of school work. (10—IV, 57—59)

SOURCE REFERENCES

1. *Prospectus of the Manual Training School of Washington University*, St. Louis, Missouri, November, 1879.
2. *Catalogue, Washington University*, 1878—79.
3. Coates, Charles Penney. *History of the Manual Training School of Washington University*. Bulletin, 1923, No. 3. U. S. Bureau of Education, Washington, D. C.
4. *Report of the Commission on Industrial Education Made to the Legislature of Pennsylvania*, Harrisburg, 1891.
5. *Forty-fifth Annual Report of the Board of Education*, Massachusetts, for the years 1880—81.
6. *Fifth Annual Catalogue of the Manual Training School of Washington University*, St. Louis, 1884—85.
7. *Report of the Commissioner of Education for the year 1893—94*. Washington, D. C., 1896.
8. Woodward, C. M. *The Manual Training School*. D. C. Heath & Co., Boston, 1887.
9. *The Journal of Proceedings and Addresses of the National Education Association*. Madison, Wisconsin, 1884.
10. Clarke, Isaac Edwards. *Art and Industry*. Education in the Industrial and Fine Arts in the United States. U. S. Bureau of Education, Washington, D. C., 1892.
11. *The Journal of Proceedings and Addresses of the National Education Association*, Topeka, 1886.
12. *The Journal of Proceedings and Addresses of the National Education Association*, Chicago, 1887.
13. Woodward, C. M. *Manual Training in Education*. The Walter Scott Publishing Co., London, 1908.
14. Ham, Charles H. *Manual Training*. Harper and Brothers, New York, 1886.
15. Curtis, John Trevor. *The Public Schools of Philadelphia—Historical, Biographical, Statistical*. Burk and McFetridge Co., Philadelphia, 1897.
16. *Catalogue of the Manual-Training High School*, Indianapolis, Indiana, 1907.
17. *The Stuyvesant High School* (Courses of study and description of equipment). New York City (No date—perhaps 1906)

18. *The Cleveland Technical High School*. Circular, 1909.
19. Leavitt, Frank M. *Examples of Industrial Education*. Ginn and Company, 1912.
20. *Industrial Courses in the William L. Dickinson High School*. Jersey City, N. J. (about 1914).
21. *Second Biennial Report of the Bureau of Labor Statistics of the State of Minnesota*, 1889-1890.
22. *Course of Study*. Cincinnati High Schools, 1912.
23. *Report of the Commissioner of Education for the year 1899-1900*. Washington, D. C., 1901.

CHAPTER XI

MANUAL TRAINING IN ELEMENTARY SCHOOLS

78. **An Experiment in Boston.** During the early seventies, while the Kansas State Agricultural College was developing its system of "industrials," and while Professor Woodward in the old Philbert mansion in St. Louis was discovering the value of tool exercises as a speedy means of teaching the elements of the mechanical arts, and while he was coming to recognize the need of such instruction in the common schools, certain religious and social workers in Boston were insisting that the public schools should give more practical instruction. With this end in view, these leaders helped to turn an industrial school for boys, which had been started and maintained for recreation and social improvement, into an educational experiment which led the way toward the establishment of manual training in public elementary schools.

Back of this experiment, however, were the experiences of several years in the teaching of sewing and drawing in the public schools of Boston. As early as 1835, the girls of two grades in the grammar schools were taught sewing and knitting by their regular teachers for an hour each day. (1—51) In 1848, drawing was placed on the list of grammar-school studies. By 1864, drawing was made a required study in the Boston schools, and by 1868 a complete graded system was in use. (2—I, 234) In 1872, at the instigation of Robert Swan, master of the Winthrop School, an act was passed by the General Court of Massachusetts legalizing the introduction of sewing and other industrial subjects. Cities and towns were permitted to establish and maintain industrial schools under the superintendence of their school committees: "provided, that in no case shall the expense of any such school exceed the appropriation specifically made therefor; and provided, that nothing in this act contained shall authorize the

school committee of any city or town to compel any scholar to study any trade, art, or occupation without the consent of the parent or guardian of such scholar, and that attendance upon any such school shall not take the place of the attendance upon public school required by law." (1—52)

It will be seen that, under this law, all industrial-school work must be supported by a special appropriation, and it must not interfere with required public-school attendance. The effect of the second proviso was to encourage industrial-school work near or in public-school buildings.

In the year 1871, there was opened in the chapel of the Hollis Street Church, under the charge of Frank Rowell, a photographer, what came to be known as The Whittling School. To this school came thirty to forty boys from twelve to sixteen years of age. With "jig saws, a turning lathe, a few simple tools," and "portable workbenches," they made "brackets, match boxes, small chests, checkerboards, and such trifling things." The chief value of the instruction was said to be not in the amount of skill gained by the boys but in the bent it gave to their leisure hours. (3—28)

Three years later, another industrial school was opened in the Lincoln Building. After two more years, these two schools united and moved into a room at 23 Church Street, the use of which was donated by the city. Here were installed workbenches large enough to give each boy a working space $2\frac{1}{2}$ by 4 feet.

Each bench had a vise with common wood jaws and an iron screw, a drawer with lock and key, in which the tools were kept, and a gas burner with movable arm. Each boy was provided with a work apron of cotton drilling. All the benches, tools, and aprons were numbered, and each boy was made accountable for their care and keeping. Printed rules of the school were pasted on each bench, and every precaution taken to secure good discipline.

Thirty-two boys were admitted to the school. Their ages ranged from twelve to sixteen. About half of them were still attending the day school; the others were employed in stores and offices. . . . A rank list was kept and posted on the wall, and each boy knew how his work was estimated by consulting the list. A course of twenty-four lessons in wood carving was prepared, with special reference to securing the greatest amount of instruction with the least expenditure for tools and material. It was not designed to make finished workmen in wood carving, but to take advantage of the

natural inclination towards handicraft. . . . The tools used . . . were the flat chisel, the gouge, and the veining-tool, or small gouge. Smooth blocks of whitewood, six inches long by two or three inches broad and one and a half inches thick, were the material worked upon. (4—194) (Fig. 125) . . . In one of these lessons, cherry was substituted for whitewood, but it was too hard for the younger boys. It will be noticed that no specific article was made in the school. The variety of manipulations and change of patterns were enough to maintain the freshness of the scholars' interest without introducing the manufacture of any article of trade or commerce.

The object of the school was not to educate cabinetmakers or artisans of any special name, but to give the boys an acquaintance with certain manipulations which would be equally useful in many different trades. *Instruction*, not *construction*, was the purpose of this school. After the blocks were finished, they were placed in a rack on one side of the room, and each boy's progress could be seen by consulting those specimens of his work.

The blocks were prepared by the teachers before the school opened. If another term of instruction could have been given, the boys would have been taught to prepare the blocks themselves. (4—195)

In the preparation of this course, the teachers of the school were assisted by Professor Channing Whitaker of the Massachusetts Institute of Technology. Dr. John D. Runkle, in his famous chapter, "The Manual Element in Education," referred to this course as an "excellent example of the Russian method of mechanic-art education"—the teaching method involved was the same as that which had been previously worked out in the bench course in metals at the Institute of Technology by Professor Whitaker and Valentine Wallburg. (4—193) (cf. 71)

In December, 1876, the group of men who were promoting the carving school on Church Street met at the Hollis Street Chapel and formed an organization called the Industrial School Association. Reverend George L. Chaney was elected its president. The "importance and feasibility of making manual education a part of public instruction" was one of its leading topics of discussion. The wood-carving school experiment had convinced them that the Russian system of "manual education may be made an efficient part of the public instruction." (4—219)

However, when it came to selecting the subject matter for a course best suited to supply public-school needs, the Association decided upon "a course in the use of the common

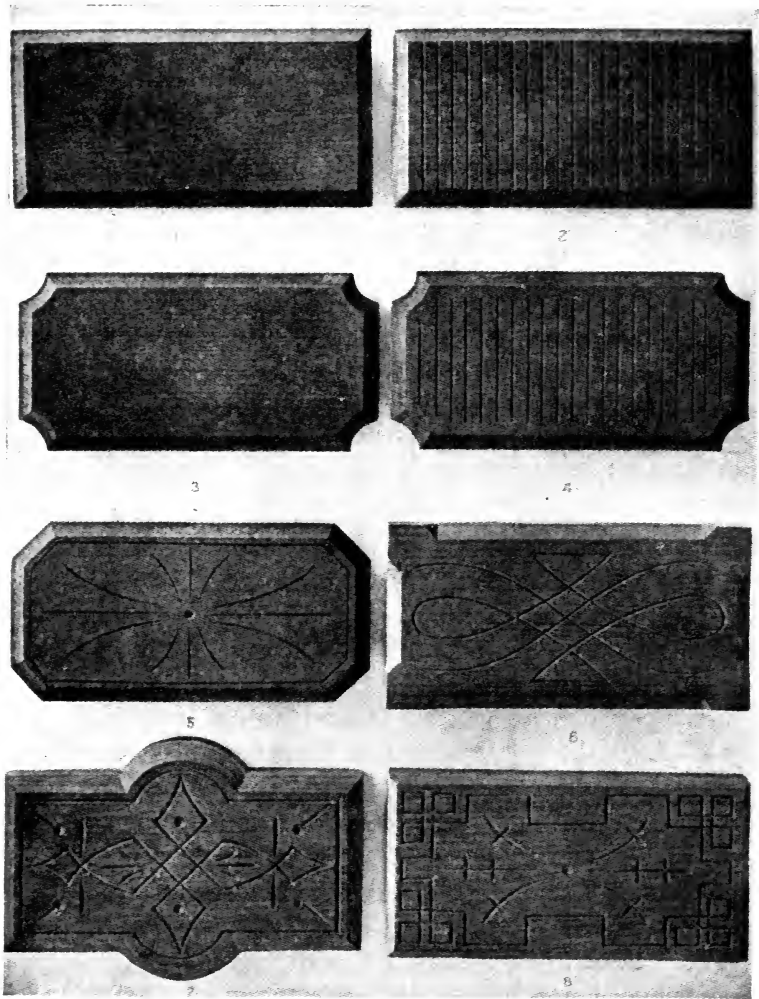

FIG. 125. THE FIRST EIGHT OF TWENTY-FOUR EXERCISES IN WOOD CARVING, USED IN INDUSTRIAL SCHOOL, BOSTON, 1874

woodworking hand tools . . . which would teach the primary arts of the carpenter, the joiner, the shipbuilder, the cabinet-maker, and of all the other craftsmen who practically use these tools. The students would 'lay out' their own work, so that this course would very properly follow the public instruction . . . given in constructive drawing." (4—219, 220)

In order to make "class instruction easy and efficient," the Association believed it desirable to have "a carefully prepared printed text, precisely setting forth every detail essential to the best performance of each manipulation." (4—220) Therefore, they authorized a committee, of which William R. Ware, professor of architecture at the Institute of Technology, was the chairman, "to employ the best service which they can command" in the preparation of such a text. This action resulted in the book, *Woodworking Tools: How to Use Them*, copyrighted in 1881 by the treasurer of the Association, and published by Ginn, Heath & Co. The plan for this first American textbook on school-shop woodworking originated with Professor Channing Whitaker. (5—IX) Associated with him, however, in the work of writing was Raymond D. Chapell, who tested the first draft during the winter of 1877-78 while teaching at the school maintained by the Industrial School Association at 23 Church Street and in the School of Mechanic Arts of the Massachusetts Institute of Technology. George H. Chapman, R. L. Bridgman, and others, also assisted. The manuscript and illustrations were tested in several classes in Cambridge taught by J. Phillips White and in a school in Gloucester, Massachusetts. (5—V, VIII)

In Gloucester, Miss Marian Hovey "placed at the disposal of the school committee a sum of money to be expended for the industrial education of boys." Four classes of twelve each received instruction on Saturdays. This work began in 1878. By 1880, one half of each afternoon session, Monday, Tuesday, Thursday, and Friday (two classes each session, eight classes in all), were given to woodworking. The course was elective. The work was under the direction of the superintendent of public schools, L. H. Marvel, and the classes were taught by

C. H. Dow, a practical carpenter. After some experience, the superintendent recommended that a half day each week be given to drawing and manual training. He said that the cost of equipping a shop need not exceed \$500, and he estimated that the per capita cost of instructing 320 pupils in such a shop need not be more than \$3.00 a year.

Another fact concerning this early work in Gloucester should not be overlooked: Although originally intended for boys, six girls were admitted to the woodworking classes in 1878, and two or three years later there were two full classes of girls and a mixed class. (2—970—972)

While these experiments were under way, an important discussion was precipitated by a report presented at the annual meeting of the American Social Science Association in Boston on January 10, 1877. This report was entitled "Report on a Developing School and School Shops." The chairman of the committee and originator of the plan recommended was S. P. Ruggles, an inventor and practical mechanic. On the committee were two distinguished public men, Wendell Phillips and Edward Everett Hale, and two additional men acquainted with practical affairs. In the light of what took place thirty years later in that same State and elsewhere, this early report takes on special significance.

The report recommended what was called a "developing school," where any boy might go after completing his general education in a public or private school. In this school, by trying one kind of work and then another, he would discover what trade or business he wished to enter. In illustrating the character of this school, the report says:

Imagine, if you please, one very large room, with a steam engine and boiler in the middle of it, so that all pupils that have any taste for the management of steam, or steam engines, could examine every point, and readily understand all about it. Then we would have a carpenter's bench, with a variety of tools, to show how that work was done; then perhaps turning lathes, to show how the wood-turning business was performed; then, with the aid of blackboards and carving tools, it might be seen how drawing and carving is done, by those that have any inclination for that business. We should also have planing machines, lathes, upright drills, jig saws, etc., to represent the machinist's business. Foundry work should be shown by having the usual fixtures for sand, and two- and three-part flasks for molding, etc.; the casting

could be done in soft metals, as lead, zinc or tin, which could be re-used; as the whole art in foundry work consists in the different manner of molding, and almost all other trades or methods of doing work could be pretty well represented in the same room.

As soon as it should be ascertained what kind of business the pupil is best fitted for by nature, he would be recommended to the school shop where that *trade* should be taught, and be more thoroughly instructed in two years, and become a better mechanic, than in six or seven years under the old system of learning a trade. (6—4, 5)

Thus the report presented the germ idea of what in recent years has become a school of mechanical trades with a preliminary vocation-finding course.

The report proposed to have each shop very completely equipped—much more completely than any shop run for profit—and every student taught the whole of his trade. Each student should make the whole of a machine, for example, and not merely a few pieces. The completed machines and other products of the school shops would be put on sale or sold at auction and the proceeds used in defraying the expenses of the school shops.

With public sentiment growing in favor of following up public-school instruction in drawing with some kind of instruction in the use of the tools and, with the significant experiments carried on by the Industrial School Association in cooperation with the Massachusetts Institute of Technology, the time seemed to be ripe for action to be taken by the City Council. So, in 1879, a group of influential citizens petitioned the Council to establish and support a “developing school and school shops”; but their plan was defeated. Two years later, the “developing-shop” idea had given way to the more immediately practical tool instruction of the adapted Russian System, and the School Committee in its report of 1881 discussed the question at some length. This report said that the term “industry” was “far too large to be adequately comprehended under any use of carpenter’s, machinist’s, or blacksmith’s tools. These are but portions of a vast field, which only a great number of special schools could make any pretension of properly traversing. But it is possible to meet some of the complaints, which are so

frequent, that the public education is so exclusively intellectual as to unfit the majority of youth for entering heartily into the ranks of manual labor, by directing certain pursuits of the school hour to the especial end of training the hand and eye; so that whatever the future occupation of the child, he will not be utterly awkward and helpless in the everyday responsibilities of earning his living." (7—54)

This report also pointed to the "eminent success" of the sewing instruction in the schools as affording "convincing evidence that it is possible to impart special manual skill without interfering with the established routine of study," and added that the teaching of industrial drawing, "now pretty firmly seated among the essentials of instruction," is quite in line with the proposed instruction in manual work. The School Committee thought "it would be no unwise venture to devote a small portion of the week in a few boys' grammar schools to an experiment of using hammers, saws, chisels, and like tools under a competent instructor, with the design of enlarging the work as fast as its smaller operations should be shown to be of advantage." (7—54)

This report and other influences brought about the much-desired public-school experiment from January to May, 1882. One of the rooms in the Dwight School building was fitted up for the purpose; a carpenter was employed for a teacher; the total cost of equipment and teacher was \$712. The following extract from the report of the principal of the school, James A. Page, reveals the success of the experiment:

On the first day of January, the instructor gave his opening lesson to a class of eighteen boys, all who could be accommodated at the three benches at one time. These boys had been selected by myself from the graduating class without reference to their standing, and no conditions were made with them except that they should not fall behind in their regular school work. Another class of the same number was selected from the second, third, and fourth classes, in order that the experiment might be tested by a wider application to ordinary grammar-school material. Many of these latter had already handled tools to a certain extent, either at home or in their fathers work shops.

In arranging the practical details of the school with Mr. Bachelder, it had been agreed that school discipline should be maintained throughout

the sessions; that the program should be carefully written out on the black-board; that each boy should be marked on the work done, and that a record of it should be kept. All this was faithfully carried out, and contributed, as I think, largely to the final success. From this beginning to the close, the school went on with unbroken and successful regularity. The teacher was promptly on hand; the order was good; the pupils interested.

It was delightful to see the eager desire manifested everywhere in the room to do the day's work well. There was no absence, no tardiness. On one occasion, a count was made, and seventeen out of eighteen pupils were found at work at one o'clock when two was the hour for beginning. It was feared that the noise of many hammers and other tools in use at once (as was necessary in giving the same lesson to a whole class) would be so great that the other rooms on the same floor might be seriously disturbed. It was arranged, therefore, that the school in the adjoining room should proceed to the hall whenever a lesson in the training room was going on. Practically, however, no trouble was felt from this source. The walls in the schoolroom were found to be so thick as to deaden the sound almost completely. It was thought also that taking a part of a class away from its regular school work would result in more or less detriment to its progress in the prescribed studies. Here and there a complaint was made by the teacher of some second-class boy, that he was not doing his work well in his own room; but the pupil, in every case, was so anxious to remain in the "carpenter's class" that a word or two of warning was sufficient to bring his performance up to the standard again.

I consider that the results go far to prove that manual training is so great a relief to the iteration of school work that it is a positive benefit, rather than a detriment, to the course in the other studies. (7—55, 56) (or 17—218, 219)

Following this experiment at the Dwight School, the school committee looked with favor upon an offer from the North Bennet Street Industrial School to give manual-training instruction to boys from near-by schools during the school hours. In September, 1883, before formal action was taken by the School committee, classes were sent from the Eliot School. In 1885, pupils from the Eliot and Hancock schools were permitted to go to the Industrial School for two hours a week, upon the written request of parents or guardians. (2—II, 338)

After two more years, the number of public-school pupils attending the North Bennet Street Industrial School was 614 a week—116 in the carpenter's shop, 118 in the printing office, 105 in the shoe shop, 116 in clay modeling, and more than 300 girls in cooking and housework. The hours of attendance were from 10 to 12 in the morning and from 2 to 4 in the afternoon. (2—II, 122)

This North Bennet Street Industrial School grew out of what was known as the North Bennet Street Industrial Home, a benevolent institution established to serve the poor of the neighborhood.

In the group of philanthropic women who were responsible for this school were Mrs. Quincy A. Shaw and Mrs. Augustus Hemenway who, during the years that followed, gave liberally of money and personal attention to the development of the type of industrial work which was adopted by the public schools of Boston and greatly influenced such work throughout the nation.

The management of this institution soon discovered that the best way to render permanent aid to the poor was to give practical instruction to the children. In studying the neighborhood, it was observed that "the inability to do anything well was the cause of most of the poverty and much of the crime." (2—II, 335) In this statement, then, one finds the early motive behind the teaching of manual training in the elementary schools of Boston; for unquestionably, in most places, the practical or social motive preceded the pedagogical or strictly educational motive in the elementary as well as in the secondary schools.

79. Testing New Theories in New York City. In the City of New York, as in Boston, the introduction of manual training into the public elementary schools was the direct result of agitation and demonstrations in connection with church missions and philanthropic institutions. Because sewing, cooking, and woodworking instruction were unquestionably beneficial to the few boys and girls who came to privately supported classes, there was reason to believe that it would be beneficial to all boys and girls if made a part of public-school instruction.

In New York City, in the early eighties, there were started two separate lines of industrial-educational endeavor, each with an inspired leader, and each of which today is represented by an outstanding educational institution in the Metropolis, and both of which received their initial impulse from the kindergarten of Froebel. The first was the kitchen garden

work of Emily Huntington, which broadened into the Industrial Education Association and then, through the influence and work of Grace Dodge (1856-1914), by a process of rapid changes, became the New York College for the Training of Teachers and then Teachers College of Columbia University. The second began with the first free kindergarten in America, which soon developed into the Workingman's School, broadened into the Schools of the Ethical Culture Society, and has culminated in the present Ethical Culture Schools—a continuous, consistent evolution of progressive education for half a century under Dr. Felix Adler (1851-1933). Largely due to the first of these, manual training became a factor in elementary public-school work in New York City.

In 1874, Emily Huntington came to New York to take charge of the Wilson Industrial School for Girls at Saint Mark's Place, an institution founded in 1854 and supported by charitable Christian women. In 1876, she visited a kindergarten exhibition and saw the children joyfully playing with blocks, and singing their songs of labor. While watching them, the idea of substituting miniature household utensils for the kindergarten gifts and occupations came to her as an inspiration. She began at once to apply the idea. She fitted up rooms with child-size furnishings and wrote songs that delighted the children and their parents; housework became play. (2—II, 256-260)

Grace Dodge became interested and "gave wings" to the work by writing about it, by talking about it, and by enlisting others in the movement. In 1880, the Kitchen Garden Association was organized to standardize and promote the instruction, and Miss Dodge was elected its corresponding secretary. The movement spread to many other cities and even to Europe and the Orient. (8—63, 65)

By 1884, Miss Dodge and several other members of the association saw the need for a broader work, a work involving industrial training for older children, and so the Kitchen Garden Association was dissolved on March 21, 1884, and the Industrial Education Association was organized on the same

date. (8—121) (2—II, 264) Quoting from the Constitution of the new association, its objects were:

First. To obtain and disseminate information upon Industrial Education, and to stimulate public opinion in its favor.

Second. To invite cooperation between existing organizations engaged in any form of Industrial Training.

Third. To train women and girls in Domestic Economy and to promote the training of both sexes in such industries as shall enable those trained to become self-supporting.

Fourth. To study and devise methods and systems of industrial training and secure their introduction into schools; also, when expedient, to form special classes and schools for such instruction.

Fifth. To provide instructors for schools and classes and, if necessary, to train teachers for this work. (2—II, 269)

This new organization brought men as well as more women into the work. General Alexander S. Webb, president of the College of the City of New York, was elected president, and Grace Dodge, vice-president, though she did the active work of a president. Dr. F. A. P. Barnard, president of Columbia College, and Seth Low, who later became president of Columbia University, were among the honorary members. Theodore Roosevelt was a member of one of the standing committees. Beginning May 1, 1885, the headquarters of the association was in a room at 21 University Place, and classes of girls were taught "true domestic service" at 54 East 11th Street. (8—123, 124)

The second annual report opened with an explanation of the intended significance of the word "industrial" as used in the name of the association. This word had given the impression that the purpose of the organization was to teach trades or "to introduce the teaching of trades as a feature of public education." To correct this false impression, the report quoted the following from an article written by Washington Gladden and published in *The Century* magazine:

There is an industrial training which is neither technical nor professional, which is calculated to make better men and better citizens of the pupils, no matter what calling they may afterward follow; which affects directly, and in a most salutary manner, the mind and character of the pupil, and which will be of constant service to him through all his life, whether he be wage worker or trader, teacher or clergyman. The training of the eye and of the

hand are important and essential elements in all good education. These elements the State is bound to furnish. (2—II, 276)

To promote the introduction of such industrial training into schools of all grades was declared to be "the great object" of the Association. While working to accomplish this great result, however, the Association proposed to furnish an example of the kind of education it advocated.

The outstanding event of the early years of the Association was the Children's Industrial Exhibition held in Cosmopolitan Hall from March 31 to April 6, 1886. This had been suggested by Charles A. Barnard, writer on things mechanical and electrical, and was carried forward with skill and enthusiasm. (8—125-127) The purpose of the exhibition was to arouse public interest in industrial education by showing what was being done in New York in contrast with industrial work being done in other cities where systematic instruction was given. Special invitations were sent to several cities and all local schools were urged to contribute.

"More than sixty schools and institutions, representing ten large cities and a number of towns and villages, and embracing all grades of manual training, from its first steps in the kindergarten to its full development in the manual-training school, took part in the exhibition." (2—II, 281) Things done and made by 3,000 children were on display and 7,000 people came to see them. Many came from neighboring cities and towns. A printed catalog of 88 pages gave information concerning the schools sending exhibits. Out-of-town exhibits came from Philadelphia, New Haven, Jamestown, Montclair, to mention only a few near-by places, and from as far west as Cleveland and Chicago. (9— —)

The results began to appear immediately: The office of the Association became the popular center of information on industrial education; the demand for teachers increased; citizens who saw the display of children's work began to ask why the New York City public schools were not represented in the exhibition; newspapers continued to discuss the question; and on November 1, 1886, Mayor Grace appointed Grace Dodge and Mrs. C. R. Agnew as members of the

Board of Education. This was the first time a woman had received such an appointment in New York City. (8—134) At once, Miss Dodge began to gather first-hand information concerning the public schools, and soon she was doing committee work. In June 1887, the Committee on Course of Study and School Books, of which she was a member, made a report commending the introduction of manual training into the public schools. The committee recommended instruction in the following subjects not then included in the course of study: in the primary grades, "construction by the use of splints, wire, thread, paper, pasteboard, and clay of the forms now prescribed in the course for drawing"; in the grammar grades, drawing to scale, sewing and cooking for girls, and woodworking for boys. These grammar-grade subjects were to be taught by special teachers. The cooking and shopwork were to be introduced only as fast as appropriate rooms for the purpose could be provided in the school buildings. To secure efficient instruction, an assistant superintendent was to be appointed to supervise the manual training. (10—9, 10)

In order to find time for instruction in these new subjects, the report proposed that less time in the upper grades be given to geography, history, and arithmetic, and in the primary grades, "partly by consolidating into one subject several matters now treated separately, and partly by a change in the method of instruction through the use of the exercises herein proposed." (10—9)

In the following October, this report of the Committee on Course of Study and School Books was adopted by the Board of Education, and the Committee directed to frame a course of study in harmony with its report. Such a course, known as the "Manual-Training Course of Study and Teachers' Manual," was published in 1888.

In this course, shopwork for boys was outlined for five grades. The lowest began with knife work, using thin wood splints. The forms, such as butt-joints, squares, rectangles, and Grecian borders, were to be drawn on paper, and the splints cut to fit the drawing and then glued to the paper.

Then $\frac{1}{4}$ " square stock was used in making tiny half-lap joints and frames, the knife being the cutting tool. After that came a rather severe course of exercises in the use of the plane. The second year's work began with sawing exercises and the making of a box; then came hammer-and-nails exercises, and finally the use of the chisel and chisel exercises. In the third year, chamfering and gouge exercises, making simple moldings; followed by the use of the rip saw in making an end mortise joint. The work of the fourth year consisted of end dovetail, side dovetail, oblique side dovetail, through mortise, stub-mortise, and scarf joints. The fifth and last year was devoted to the making of a dovetailed box $11'' \times 7'' \times 6''$, with hinged and hooked top. (11—133—141)

Thus, with a course of exercise pieces, joints, and a few constructed pieces in woodwork, and a course of geometric problems in mechanical drawing, manual training was introduced into a few public schools in New York City in 1888. The most significant fact about this new course as a whole, however, is that it was an effort to introduce "manual methods" in teaching the regular school subjects of that time, which involved placing special emphasis on form study, drawing, modeling.

Paralleling the pioneer work of Grace Dodge and her associates in the Industrial Education Association and on the Board of Education was that of Felix Adler and the Workingman's School. While Miss Dodge's efforts were those of a philanthropist, an organizer, and a financial manager, Dr. Adler's were those of a philosopher, an intellectual leader, and an educator. Though working separately, each, in a measure, supplemented the other.

After graduating at Columbia College in 1870, Felix Adler studied in the Universities of Berlin and Heidelberg, receiving the degree of Doctor of Philosophy in 1873. In May, 1876, he and several liberal-minded associates formed the New York Society for Ethical Culture. This brought together thinking men and women who had drifted away from the current religious creeds and who desired to cooperate in a movement to teach "the supremacy of moral ends above all

human ends and interests." The ethical training of children soon became one of the chief purposes of this society. In 1878, the first two free kindergartens in the United States were opened through the efforts of Dr. Adler—one in New York City and the other in San Francisco. Fannie E. Schwedler was the first principal of the Free Kindergarten in New York. In 1880, the Workingman's School was opened by the Society of Ethical Culture as a continuation of the Free Kindergarten. It extended its instruction up through the elementary-school period. Dr. Adler's aim was to develop a superior system of education extending over the child's entire school life. (2—II, 463-465)

Dr. Adler's philosophy of industrial activities in the schools, as stated in a notable address at the opening of the Workingman's School, is given, in part, in Source Material XI A at the end of this chapter. To supplement this are the following excerpts from an article in the *Princeton Review*, March 1883:

The salient feature of the new experiment is that it introduces what may be called the *creative method* into school education. The system of teaching by object lessons has long been familiar to educators. It is proposed to improve upon this system by giving lessons in the *production* of objects. The step forward taken by Pestalozzi, when he summoned teachers to desist from the vain work of teaching the names of things, and to lead their pupils rather to a first-hand observation of things, marked a new epoch in the science of pedagogy. At present, still another step must be taken, viz, from the mere observation to the production of things as a means of acquiring knowledge; and the taking of this step will mark another epoch in pedagogy. Froebel began to apply the principle of the creative method in his Kindergarten. But the kindergarten system covers only three years of the child's life; while, for the school age proper, no valuable and tangible formulation of the creative principle has yet been given. (2—II, 492-493)

. . . I have thus far spoken only of the value of the creative method for the culture of the intellect. But we who desire an "all-sided" rather than a "one-sided" development of the child must take into account the aesthetic and moral nature as well; only by the harmonious culture of all three can the larger humanity be perfected; and the creative method must show itself capable of giving a powerful stimulus in all these different directions if it would vindicate its title to the high significance which we are inclined to ascribe to it.

Now it is easy to see that the production of beautiful forms by the pupil will tend to heighten his appreciation of what is beautiful, and to refine his taste. I here speak of the school atelier as I have before spoken of a

school workshop. Both are equally needed to supplement the classrooms of the ordinary school. In the latter, mechanical drawing is made the basis of instruction, and the work executed is the means of creating mathematical precision; in the former, freehand drawing is the basis, and the work done is the means of cultivating a sense of harmony and of beauty. (2—II, 495)

In such a system of education Dr. Adler believed that industrial work should be an organic part of the whole. How he caused it to be interwoven with the other school work in an effort to produce a unified whole in the Working-man's School is suggested by Gabriel Bamberger, principal of the school in his report in 1887:

Pupils of the lowest classes work in clay, using compasses, rulers and blunt knives; they draw upon the clay, and afterwards cut out the simple plane figures, acquiring in this way the elementary ideas of geometrical forms. Pupils next above these grades use pasteboard as material, and sharp knives, awls, etc., as tools. The work consists of a series of exercises in stereography, the various geometrical solids being drawn in flat projection, and afterwards folded up and glued into shape. Passing above this grade, pupils next work in flat wood, using the necessary tools, including the bracket saw. Mensuration of areas is taught by this means. Next above this comes a series of exercises upon geometrical solids, which are constructed from blocks of wood, those having plane faces being made in the miter box, and those having curved faces on the lathe. Calculation of volumes is taught in this part of the course. For the higher classes, the exercises consist of lessons in making joints, and the elementary study of strains, followed by practice in casting and working metal, and closing with the construction of a small steam engine. At every stage of the course, the nature of limitations of the materials used, the capacities of the tools employed, and the physical and mathematical properties of the objects constructed, are impressed upon the mind of the pupil; and a firm foundation is thus laid for the future study of the natural sciences, and an intelligent understanding of abstract mathematics. Mechanical drawing accompanies the work of the shop throughout the entire course. Nothing is made until it has first been drawn, and the pupil, when he begins his construction, has thus a clear idea of what he intends to produce. The educational equivalents of our workshop instruction may therefore be summarized as follows: practice of eye and hand, illustrative value in the teaching of geometry and physics, important influence on character.

In the study of physics, pupils construct their own apparatus in the shop, and thus are placed in the attitude of original investigators into the phenomena of nature, the leadership of the teacher serving to prevent waste of effort by turning their inquiries in the right direction. The apparatus is simple in character, and easily made. Pupils perform every experiment themselves. They note down in their copybooks what they have observed; they draw deductions from these observations, and are thus led to formulate the elementary laws of nature in their own language. It need scarcely be

pointed out that this method of teaching physics is an advance upon the old, so-called experimental method, in which the demonstration is left entirely to the teacher. (2—II, 503)

80. Manual Training Given Public Support in Montclair.

In that same month of May, 1882, when the Dwight School experiment in shopwork was being completed in Boston, the voters of Montclair, New Jersey, at a school meeting, decided that "it is the opinion of the people of this school district that the pupils in the grammar schools, from twelve to fourteen years of age, be given opportunity to learn the proper use of woodworking tools under a competent instructor, and that a change in the studies and recitations of such pupils as elect to do this work, be made so as not to interfere with the regular studies of the school." (2—II, 157) One thousand dollars was voted for that purpose during the school year 1882-1883. This action resulted from the report of a committee appointed at a school meeting a year earlier, May 23, 1881, and was in accord with the advice of their progressive superintendent of schools, Randall Spaulding, who was working out his ideal of a school system for Montclair—one that should include appropriate industrial or hand training throughout the system, beginning with the kindergarten.

During the summer of 1882, "a well-lighted attic" room in one of the school buildings was equipped with benches and tools at a cost of about \$350, and John V. Shaw was elected instructor. Teaching began in this school shop on October 1, 1882, with about 50 boys "taken from the higher grammar classes. While these boys were in shopwork, the girls of the same grades were given lessons in needlework, etc." (2—II, 157) Two hours of the regular school time each week were taken for this purpose. From the first, therefore, the instruction in shopwork in Montclair was "a part of the regular work of the school," (9—42) and paid for out of *funds voted by the people of the community*.

During their first year in the shop, boys were taught the use of carpenter's tools; during the second year, they were engaged in wood carving. As a rule, pupils were expected

“to make their own designs for the wood carving. . . . The aim of the work was not to produce articles of value nor to teach a trade, but to discipline the mind through the hand and eye.” (12—56)

In February, 1884, Mr. Shaw included the following in a report to the trustees:

In the first lesson, the pupils were taught the names of the various tools, and their uses explained. In the second, the class was supplied with blocks, which were spaced off, and the practice given in striking straight blows with the hammer. In the several succeeding lessons, practice was had in driving nails, and in the use of planes and saws, in accurate boring with brace and bit, also in lining with chalk line, and in the uses of gouges, mallet, and chisels; then followed planing to gauge mark and planing boards out of “wind,” practicing in tool sharpening, etc. These exercises occupied the lessons to the sixteenth, inclusive; after which pupils were given practice in making mortises and tenons, and then taught to make a frame with halved corners. This was followed by instruction in the manner of making dovetails; also making frames with mitered joints, in the construction of which no miter box was allowed, the miters being struck out by measure. They were next instructed (drawing on blackboard) in the manner of laying out and constructing a box with corners dovetailed together. Then came practice in making frames with locked joints, or with corners halved, and the ends of wood projecting. We are now engaged on the last frame in the course of lessons, the joints of which are to be mortised and tenoned together.

In addition to this work, the carpentry classes have assisted me in constructing sixteen tool boxes for the use of the carvers; they have also made six frames of a somewhat ornamental character for mottoes, intended for the walls of the workroom. . . .

The percentage of boys who seem to have a natural aptitude for mechanical operations exceeds that of last year. We have some not over twelve years who show a proficiency beyond others of sixteen, and are giving evidence of superior ability. The ardor with which the boys continue to enter upon and pursue their studies is to me still a matter of surprise. With very few exceptions, there seems no diminution in their former eagerness to commence their work or in their unwillingness to desist when the lesson hour has expired. Some so love their work that they have requested me to let them practice a short time during the noon hour. A number have a fine artistic taste, and desire to produce beautiful objects. I have employed these in gilding the scroll and ornamental work on the motto frames, in which occupation they have been much interested, and I may say delighted. This artistic work has been done after the school hours, so as not to interfere with any of their studies. (2—II, 157, 158)

In January, 1887, after nearly five years of experience in developing his plan of making “industrial training” a regular part of school work, Superintendent Spaulding said that

not only had the results been "eminently satisfactory" but that all pupils in three grammar grades had been engaged in industrial work. (2—II, 162)

81. **Other Early Experiments.** Again in that same spring of 1882, and perhaps in that same month of May, a manual-training shop was built at Jamestown, New York, "large enough to accommodate four benches and three lathes, with a loft for storing away lumber." An outfit of tools was supplied and two young men working "under the general supervision of the janitor (a good mechanic)" gave instruction every school hour of the day. Previous to this time, a single workbench had been placed in a corridor in the basement of the school building, to which were assigned two selected boys at a time, "one to work half of the hour and the other to watch, under the direction of the janitor or one of the young men who understood the use of tools." (13—26, 27)

The cost of this beginning in shopwork instruction in Jamestown, however, was not taken from public funds. The money for this and other similar educational innovations was raised "at annual exhibitions given by the pupils, under the direction of the teachers" and encouraged by the superintendent of schools, Samuel G. Love, an enthusiastic believer in manual training. With the efficient help of Mary R. Willard, one of his teaching staff, he provided some kind of manual work for all of the grades from the kindergarten up through the high school.

Outlined by grades the course was essentially as follows:

Grade I. Block building, stringing straws, stringing beads, learning colors, tablet laying, paper folding, and drawing.

Grade II. Stick laying, picture cutting, scrapbook making, spool knitting, paper embroidery, braiding, and drawing.

Grade III. Perforated cardboard embroidery, slat plaiting, mat weaving, and drawing.

Grade IV. Crocheting, and advanced work in cardboard embroidery and slat plaiting.

Grade V. Sewing over and over, crocheting, paper folding, and mounting.

Grade VI. Hemming, knitting, construction of geometric figures and solids with short sticks or toothpicks and peas, paper flower making and drawing. (13—39 to 185)

Grades VII, VIII, and IX. Boys and girls separated, the boys taking woodwork and the girls practical work in sewing.

This was done with the approval of the Board of Education, but, in all these early years, without their financial support. All expenses, therefore, had to come out of the exhibition fund.

As early as 1874, Superintendent Love had taken \$125 out of this fund to equip a vacant room for a printing shop. This was placed in charge of "the commercial teacher who, when a boy, had worked in a printing office." Two classes of boys and girls of four each were selected from grammar and high schools to learn to set type. They were given two hours or more each week during the school year. (13—22)

In 1884, two wings were added to the high-school building which provided two well-lighted basement rooms, each about 28 by 37 feet, for manual training. One of these rooms became the woodworking shop; the other was used for a printing shop and a sewing room. The old shop building was fitted up for a kitchen for instruction in cooking. (13—37)

By 1887, all the children in the first six grades, about 1400 in all, were given from three to five lessons a week in some kind of manual work. In the upper grades and high school, not all the pupils received instruction in manual training; but 125 of the girls were taught sewing and 65 of the boys woodworking twice or three times a week, and 20 boys and girls set type in the printing shop one hour on four days of the week. (13—28)

By this time, the manual-training work at Jamestown had attracted wide attention among educators, and Mr. Love was urged to publish his course of instruction. This appeared in 1887 as a book of 306 pages under the title *Industrial Education* and the subtitle "A Guide to Manual Training." It was illustrated with 373 line drawings grouped in full pages. The book outlined the various kinds of manual work done by the children of the lower grades and then the lessons in shopwork, beginning with striking light, medium, and heavy blows with the hammer, and taking up the other tools, one at a time, in a course leading up to a blind-dove-tailed miter joint. A chapter was given to foot-power machines, including the lathe, the scroll saw, and the circular saw. There was a chapter on wood finishing, one on drawing

and construction, and another on printing. Work in sewing and cooking were more briefly outlined. Just as the book, *Woodworking Tools*, developed in Boston, exerted a very positive influence on early courses in woodworking in the public schools, so this book served to broaden the conception of what was meant by manual training in public education. Those who read this book, or even merely looked at the illustrations in it, realized that manual training meant much more than making a series of joints out of blocks of wood.

New Haven, Connecticut, under the progressive superintendency of Samuel T. Dutton, was one of the earliest cities to give manual-training work a fair trial in its public schools. To L. L. Camp, principal of the Dwight School, and J. R. French, of the Skinner School, is given the credit for having initiated an experiment in 1883 that resulted in building up an effective system of manual training in a very few years. A large basement room in each of these schools was fitted up with benches and tools for a class of twelve boys. At the Dwight School, sixty boys were "selected for superior scholarship" to receive instruction in woodworking. In a similar way, thirty boys were selected at the Skinner School. The ninety boys received instruction twice a week for an hour from the janitors of these schools who were much interested in the experiment. The cost for the first year was \$200, only one half of which was paid out of school funds. The work was popular with pupils, parents, and teachers from the beginning.

Some of the difficulties experienced elsewhere were avoided by basing the selection of pupils on good scholarship. Superintendent Dutton's statement concerning this plan was as follows:

Close students are often persons of highly wrought nervous temperament, who especially need relaxation and physical training. Those whose surplus energies are spent in outdoor sports, or who have active duties out of school, have less need for manual training. The fact that the dignity of labor may thus be popularized, and that many boys not members of these classes will be inspired "to do something," is a strong argument in favor of the plan. It is the industrial and industrious spirit that we want in our schools, and in the community as well, so that honest labor may be not only respectable

but honorable. It must be counted a misfortune that popular intelligence does not yet grasp the principles which underlie an education which begins in the kindergarten and carries the industrial and productive idea through all grades. (2—II, 1156)

Something of the character of the instruction in New Haven can be gained from the statement of Mr. Camp in 1885:

While teaching the correct use of tools has been our chief object and aim, yet, in addition to the numerous small articles and blocks upon which practice has been given, the pupils have made 14 molding tray tables, 12 sewing tables, 74 stools, 4 small cabinet boxes, 3 black walnut book shelves, 2 tool chests, 2 easels, 1 bookcase, 1 lap cutting board, 1 knife tray, 1 inlaid checkerboard, 4 drawing boards, besides a great number of small articles. There are also now in the process of manufacture numerous tables, stools, boxes, bookcases, etc.; so that there is real money value to the work the pupils have done, though that is not the object aimed at in the formation of the industrial classes. (2—II, 1158)

Mr. French said:

The purpose has been to produce useful articles, and most of them have met with ready sale. Many parents are anxious to own the objects made by their sons, and the sale of these has enabled us to obtain needed supplies without overdrawing the appropriation. All have been eager to work in the shop as much as possible and, during intermissions and on holidays, it has been a common thing to see some of them busy at the benches. (2—II, 1159)

Some instruction was given in wood carving and a little in clay modeling.

In 1884, Joseph Carter, superintendent of public schools at Peru, Illinois, upon his own responsibility and with his own money, purchased twenty sets of carpentry tools and ten workbenches, and fitted up the basement of one of the school buildings as a workshop. To these, he added other equipment, including carving tools and scroll saws. This action at first aroused general criticism; some objected to such useless expenditure of money; "others ridiculed the idea of engrafting such a monstrosity upon the public schools." But gradually these objections were overcome and the results shown disarmed the criticism. At first, instruction was given by a carpenter; but a little later, A. R. Jolley, a high-school teacher, was placed in charge of the shopwork. He gave three fourths of his time to teaching other high-school

subjects and one fourth to teaching manual training. Of this combination, the superintendent said in 1887, "This arrangement has been found to work admirably; in my opinion it is much to be preferred to putting the work in charge of a regular carpenter. A fair knowledge of tools and how to use them, plus the knowledge of how to teach, make the best combination for a manual-training instructor."

The course of instruction outlined for this school, instead of being a series of exercise pieces and joints, consisted of useful objects:

FIRST YEAR, FIRST TERM

First Month

1. Teach the use of the square in measuring and in laying out right angles.
2. Sawing to the line with rip and grain saws.
3. Planing boards to uniform width and thickness with jack, fore, and smoothing planes.
4. Nailing: the proper holding of hammer; setting the nail; striking square blows.
5. Make a small, plain footstool.

Second Month

This time is spent in making a knife box, or similar piece, all the pupils doing the same kind of work.

The use of the backsaw, miter box, and scroll saw are taught.

Third Month

This time is spent upon a boy's sled or some similar piece. The use of the dividers, brace and bit, are introduced here.

The main advance in this step is in passing from soft to hard wood.

FIRST YEAR, SECOND TERM

1. Plan and make a wash bench.
2. Lay out irregular curves, and saw the same.
3. Cut chamfers with chisels; make joints.
4. Sharpen and set tools.

FIRST YEAR, THIRD TERM

Object for construction, a tool chest. During this term, the pupils are taught to cut miters with miter box and with planes; also to construct a box with mitered corners; to use the turning lathes; to make double joints; also mortise-and-tenon joints.

SECOND YEAR

During this year the pupil exercises his individual preference as to what pieces he shall construct. In this, he is guided by his boyish fancies—what is needed in the family, or what he can make and sell to someone. There are finished up such pieces as tables, cupboards, book shelves, brackets, cabinet cases, flower stands, stepladders, etc.

MATERIAL

Each pupil pays the cost price of the material which he uses; this money, which nearly pays the running expenses of the workshop, is turned over to the school treasurer. (2—II, 193)

The introduction of manual training into the public schools of Peru should not be considered without mention of a previous effort to give the boys of that community some industrial training.

Late in the year 1876, under the leadership of Mrs. E. C. Holmes, who came from Gloucester, Massachusetts, the Women's Christian Temperance Union organized a Boys' Working Club. (It is probable that Mrs. Holmes was acquainted with the industrial-school activities of that time in Massachusetts.) For the use of this club, "a shop was fitted up with a dozen work benches, woodworking tools for two dozen boys, and a dozen tables for scroll-saw work." Competent carpenters were employed to teach the boys. They worked two evenings a week from 7 to 8 o'clock and on Saturday afternoons from 2 to 5. These particular hours were selected so as not to interfere with school or other duties. Along with the woodworking was some moral instruction given by members of the Women's Christian Temperance Union. This club work continued during the winter and spring months. It was supported by voluntary subscriptions, by sales made at annual fairs, and 10 cents per pupil per week for instruction. There were 40 boys the first year, 50 the second, and many were turned away because of lack of room for them. The work was discontinued after three years because the burden of carrying it on became too heavy for the women remaining after some of the leaders were gone. The success of the club prepared the way for the public-school manual training that came a few years later. (2—II, 191, 192)

In Philadelphia, as in Boston and New York, the beginning of the movement for manual training in the public schools grew out of organized philanthropy. In 1880, Charlotte Pendleton of the Society for Organized Charity made a report on the care and education of dependent children which called attention to the failure of the public schools "to prepare citizens for self-support." She emphasized certain defects in the schools and told what had been done in other cities to remedy them. Her second report, in April 1881, gave the results of a questionnaire which she sent to a few prominent citizens of Boston and Philadelphia. The essential fact reported was that they all believed in manual instruction and all but one believed that such instruction should be given in the public schools. This report recommended the formation of an organization to help bring about reform in the public schools of Philadelphia. Action on the recommendation was taken at once, and the Public Education Association came into being, with Miss Pendleton as its secretary. Through the years that followed, this Association was a very important factor in bringing about many reforms in the public-school system. (2—II, 989—1000)

On the original executive committee of this association was an enthusiastic believer in art education through the "minor arts"—Charles Godfrey Leland, an American author, who had helped to start the Home Arts Movement in England. Mr. Leland was successful in convincing the School Board's committee on industrial education of the feasibility of his system of manual training, and the committee arranged for an "experimental trial" of his system. (14—20) "The plan was to start in a central school house, where there were vacant rooms that could be used for the purpose, and to select the children from the schools all over Philadelphia. The teachers interested enough to want to come were to have a special class in the evening. The school house chosen was the Hollingsworth in Locust Street above Broad." (15—II, 102). Mr. Leland, who had never taught before, gave instruction in drawing, wood carving, and working in metal and leather. For this teaching, he received no pay; he was trying to

demonstrate the effectiveness of his plan of teaching the minor arts as a system of manual training in public schools. Other artists volunteered to help him. (15—II, 103)

The theory upon which Mr. Leland was working was that "interest in the minor arts develops general intelligence"; and "that knowledge of how to make things is of immense value in stimulating in every mind a love of industry." He regarded the minor arts as merely "drawing in different materials with different implements." Design he regarded as "the root which sends forth endless flowers," and it should begin with mastering the spiral. The free drawing of curves was therefore a foundation for all the arts in his school. (15—II, 105)

Thus began the Industrial Art School of Philadelphia. After three years, Mr. Leland returned to England; but many of his ideas continued to influence the school. The manual training, however, that finally took root in the public schools grew out of experiments after the establishment of the high-school work in manual training in 1885.

During the years, 1884 to 1888, manual-training instruction was begun in the public elementary schools of several other cities. Among these were Omaha, Nebraska, in 1885; Springfield, Massachusetts, in 1886; Beardstown, Illinois, and Washington, District of Columbia, in 1887.

In Omaha, the teacher came from the St. Louis Manual Training School. About half of the pupils were from the eighth grade and the remainder from the high school. (2—II, 430) In Springfield, fifty-four were from the ninth grade of the elementary schools and thirty from the high school.¹ The instruction was given by George B. Kilbon, a skilled mechanic and an enthusiastic teacher of boys. In Washington, manual training for high-school boys was begun in 1886 with one instructor, Walter G. Wesson from the Worcester Polytechnic Institute. In 1887, it was extended to take in classes from the seventh and eighth grades.² In Beardstown,

¹From data furnished by Burton A. Adams, supervisor of manual arts, Springfield, September 27, 1932.

²From data furnished by John A. Chamberlain, supervisor of manual training, March 21, 1929.

about fifty boys of the upper grammar grades were taught woodworking by a graduate of the St. Louis Manual Training School. (16—83)

After 1887, manual training developed rapidly in the grammar schools. Each year thereafter saw several new cities added to the list of adoptions. In most places, the grammar-grade instruction consisted of benchwork in wood; but there was little uniformity in the courses given and not much more in methods of teaching until after the Columbian Exposition in Chicago in 1893. The exhibits shown there—especially those from Boston—exerted a strong influence on the grammar-grade work of the entire country. Previous to that time, the prevailing methods of organization and teaching in the high schools were of Russian origin. After that time, the grammar-grade work soon took on the character of the work in Boston, which had been greatly influenced by the Swedish sloyd.

82. Typical Grammar-Grade Course Developed in Boston. From what has been said already concerning the beginnings of manual training in elementary schools, it should be clear that the year 1882 was an especially important one. To still further emphasize that fact, one more event in that year should be mentioned. In the summer of 1882, Professor John M. Ordway of the Massachusetts Institute of Technology visited Sweden and returned with a glowing account of the sloyd instruction in that country. (cf. Chap. II) He visited a sloyd shop in a public school in Stockholm and gathered much information, though it was in vacation time and no classes were being taught there. He visited August Abrahamson, founder of Nääs, and Otto Salomon with his summer class of teachers and his model school of boys. In reporting to John W. Dickinson, then secretary of the State Board of Education in Massachusetts, Professor Ordway said, "I was much impressed by the prevalent interest which is there practically shown in handwork instruction. While the other nations of Europe have only here and there taken some tentative steps towards meeting the requirements of the age, this free-minded northern people have gone forward in earnest and

have found it possible, with very limited means, to enlarge in the right direction their already excellent system of general education." (17—163)

Professor Ordway brought back extended reports of Swedish sloyd instruction which he translated for publication in the report of the Massachusetts Board of Education. What effect his statements produced on the committee of the Board of Education appointed to report on industrial education is shown by their Report on Manual Training. (Source Material XI B) This committee especially emphasized the belief that the shopwork that was desirable for the elementary school was not "industrial training proper, but manual training given for its educational value." (17—157) The report said that "a flood of light" had been thrown upon the subject by Professor Ordway's report on the "manual instruction in the common schools of Sweden." The practical effect of this report was apparent a few years later.

When Professor Ordway was in Sweden in 1882, he saw a paper called *Slojdaren* edited by Lars Erikson. He wrote to the editor and, in the correspondence that followed, suggested to Erikson that he come to America to teach the Swedish system. In 1884, Erikson went to Anoka, Minnesota, where he visited his daughter, and then to Minneapolis. On December 8, 1884, in the basement of the Augstana Lutheran Church of that city, Erikson began teaching a class in Swedish sloyd. This is supposed to be the first lesson in Swedish sloyd taught in America.³ A little later, Erikson started a sloyd school in Minneapolis; but, while trying to learn the English language, he was obliged to do other work to support his family. About two years after Erikson came to Minnesota, Carl Fallen came to Boston. He was a licentiate in philosophy but had not received sufficient technical training to be a successful sloyd teacher.⁴ In 1888, he was sent west to find Erikson and induced him to come to Boston to teach in the North Bennet Street Industrial School. Erikson taught there

³From special article in *The Minneapolis Journal*, January 12, 1913, verified by correspondence with Lars Erikson.

⁴From letter written by Charles A. Kunou, October 3, 1935.

about two years but was never a great success, partly, at least, owing to his difficulties with the English language. He came to realize that he had begun to study English grammar too late in life. He returned to Minnesota.

The real influence of Swedish sloyd upon American manual training began when Gustaf Larsson (1861-1919) came to Boston in 1888, followed shortly by Charles A. Kunou and, in 1890, by Josef Sandberg. Larsson and Kunou had been classmates at the technical school in Stockholm.⁵ Both Larsson and Sandberg had studied under Otto Salomon at Nääs; Kunou had studied sloyd according to the Nääs system. The circumstances of Larsson's coming to America were told by him in these words:

Having studied sloyd in Sweden at the well-known school at Nääs, in the double capacity of pupil and teacher, I felt that a knowledge of the system should be more widely diffused than it then was. During my studies, I was more and more impressed by the importance of the work; and being convinced that a broader opportunity would not only enlarge its sphere of usefulness, but also help to develop unrealized possibilities of sloyd, I concluded to visit America, hoping to interest school boards and other promoters of education, and that their sympathy and interest would result in the establishment here (in America) of schools for sloyd. With this aim in view, I gave up temporarily my position as teacher in one of the Swedish schools, and came to the United States, arriving in Boston on the first day of July, 1888. (18-17)

Gustaf Larsson was looked upon by Otto Salomon as the ambassador of Swedish sloyd in America. Within two weeks from the time of his arrival, Mr. Larsson was teaching a summer-school class in a private school, and within a few months, he was giving instruction to a class of public-school teachers. He was fortunate in winning the approval and financial support of Mrs. Quincy A. Shaw, whose influence in educational and philanthropic Boston was very great.

The coming of Mr. Larsson and his completely organized system of manual training stimulated interest and discussion. The fact that he claimed that sloyd applied sound principles of pedagogy and that other manual-training work in Boston

⁵ibid

did not, aroused discussion and sometimes opposition to sloyd. He emphasized the importance of what he called "duality of progression." By this he meant that exercises should follow in a progressive order from simple to complex and be carefully graded with reference to the powers of both mind and hand. (18—20) He believed that the manual-training work he found in Boston did not fulfill this condition. He insisted that exercises should be grouped and taught in such a way as to always result in the making of useful articles; no preliminary exercise pieces should be allowed. This point was argued on the ground of the child's greater interest in producing a complete, useful thing, and of the social and moral values of "the useful model." (18—21) He sought to cultivate the aesthetic sense and to broaden the instruction by including articles involving freehand modeling, such as the coat hanger and the hammer handle. And he advocated individual instruction as opposed to class instruction.

In Sweden, no mechanical drawing was taught in connection with sloyd; pupils worked from models, not from drawings. In America, Mr. Larsson soon found that mechanical drawing had become such a vital factor in industry and had gained such headway in the schools of Massachusetts that he adopted mechanical drawing as a part of what he called "American Sloyd," and, in 1893, he published a book of working drawings of his sloyd models. (1—22)

In the early days of his teaching, he adhered to the Swedish idea of a fixed course of models, and he determined what models should go in the course. Later, however, his work became more flexible and he assumed that, after proper instruction, the teacher was competent to determine the course, and, in some cases, the teacher would be justified in dropping, changing, or adding new models to suit individual pupil needs. (18—35,43)

While this evolution was taking place in Mr. Larsson's ideas, and very largely the cause of it, two other strong teachers in Boston were evolving courses for the elementary schools. These were Frank M. Leavitt, and Benjamin F. Eddy. Mr. Leavitt had received his training in the School of

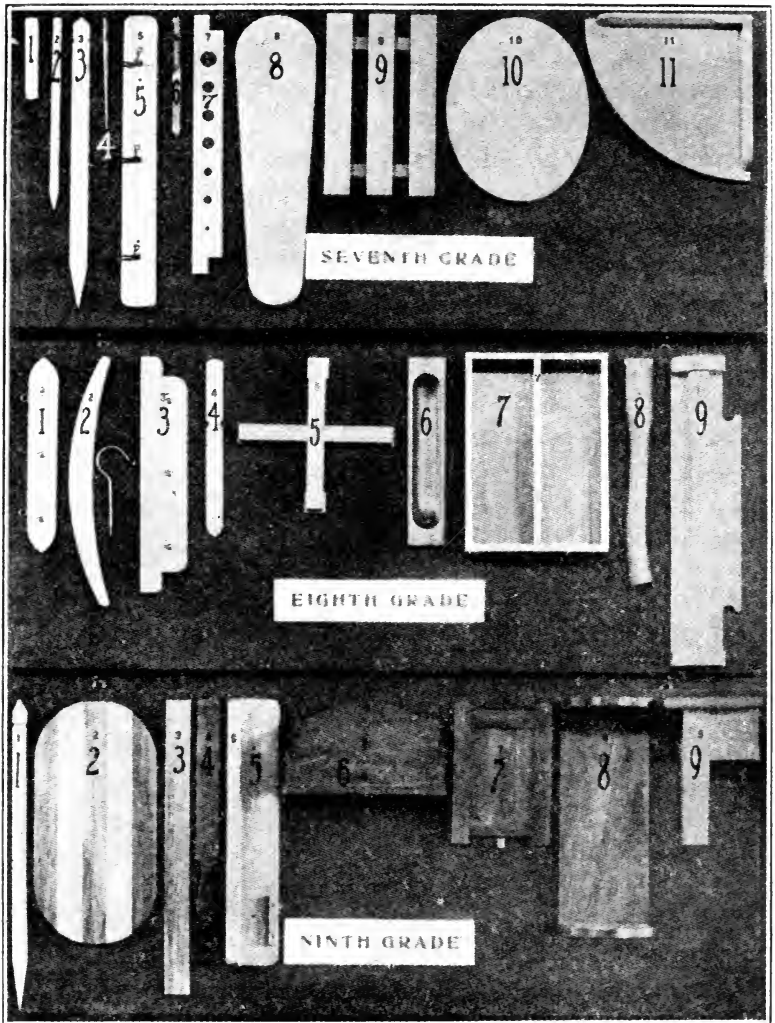

FIG. 126. COURSE IN SLOYD FOR GRAMMAR GRADES OF PUBLIC SCHOOLS
BY GUSTAF LARSSON

Mechanic Arts at the Massachusetts Institute of Technology and was therefore drilled in the fundamentals of the Russian System. He was teaching at the Eliot School in Jamaica Plain. Mr. Eddy was an expert woodworker, trained in industry, and a strong teacher. He was teaching at North Bennet Street Industrial School. These two and Mr. Larsson, at the Rice School, were looked upon by Superintendent Edwin P. Seaver as performing an experiment for the schools of Boston. In 1893, he said, "The intention of the school committee . . . is understood to be to continue the experiment for perhaps two years longer, in expectation that there may be a clear demonstration from experience of the best means by which the wants of boys in city grammar schools may be supplied, whether by the Russian shopwork or by the Swedish sloyd, or by some combination and outgrowth of the two, larger and better than either." (1—22, 23)

From his further discussion of this experiment, it is evident that he was expecting the result to be the "outgrowth" that would be "larger and better than either." What he probably did not foresee was that his experiment in Boston was producing the typical system for the grammar grades of the nation. Boston sent exhibits from these three schools to the Columbian Exposition in Chicago in 1893. They attracted much attention and received general commendation. They were studied in detail by many schoolmen and special teachers of manual training. To many visitors, they were so near alike that they appeared to be essentially one system, with small useful objects as the chief characteristic, Fig. 126. The effect was almost immediate. It was recognized that by accepting some of the so-called principles of the Swedish sloyd while continuing to apply some fundamental practices of the Russian system and harmonizing these with the best American practice in the use of woodworking tools, Boston had produced an American system of manual training that was pedagogically sound and practical. In the next few years, there was a large increase throughout the nation in the number of schools starting manual training in the upper grammar grades; and, whether conscious of it or not, a large proportion of these

followed the trend that was given direction in Boston. In 1901, Boston published its course of models for the seventh, eighth, and ninth grades, giving photographs of the completed models, working drawings, and outlines of the processes. (19—40—49) Figs. 127 and 128. This was issued under the supervision of Frank M. Leavitt, who had been promoted to the position of principal of manual-training schools in 1892. The Swedish idea of useful models had prevailed; the Russian idea of class instruction, supplemented by individual help, had not been abandoned. To a limited extent, modeling and curved forms, also chip carving characteristic of the Swedish work, were included; the American and Russian use of mechanical drawing was emphasized. To some extent, the rigid course of models had become more flexible; working drawings of suggested optional models were included in the published course.

83. Influences Tending to Modify the Grammar-Grade Manual Training. While the Russian system of tool instruction and the Swedish sloyd were the two strongest factors influencing the teaching of manual training in the early days of that work in the elementary schools of this country, there were other factors that soon acted as modifying elements. As time went on, these factors became more numerous and more influential until, at the close of the period now under consideration, up to 1918, hardly more than shadows of the original system remained in most of the progressive American courses. The Russian system, having developed to produce skilled workers as rapidly as possible (cf. Chap. I), had adopted class-instruction methods. The Swedish sloyd, on the other hand, recognizing individual differences in the speed of pupils in their work, had adopted individual-instruction methods. In America, class instruction was adopted before the Swedish sloyd came and, as it was considered effective and economical, it was retained. To develop courses and methods that would include the best features of both of these systems and be in harmony with the best American practice in the crafts and with American educational ideals became the problem of thoughtful teachers of manual training.

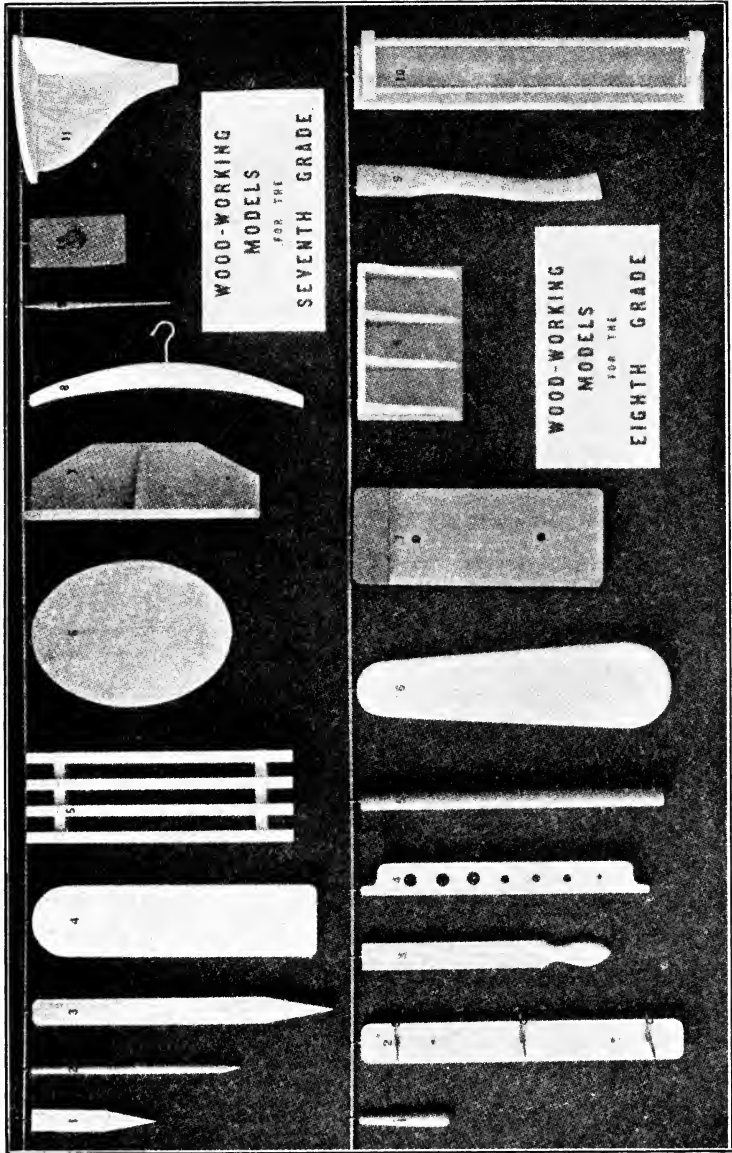

FIG. 127. Woodworking Course, Seventh and Eighth Grades, Boston Public Schools, 1901

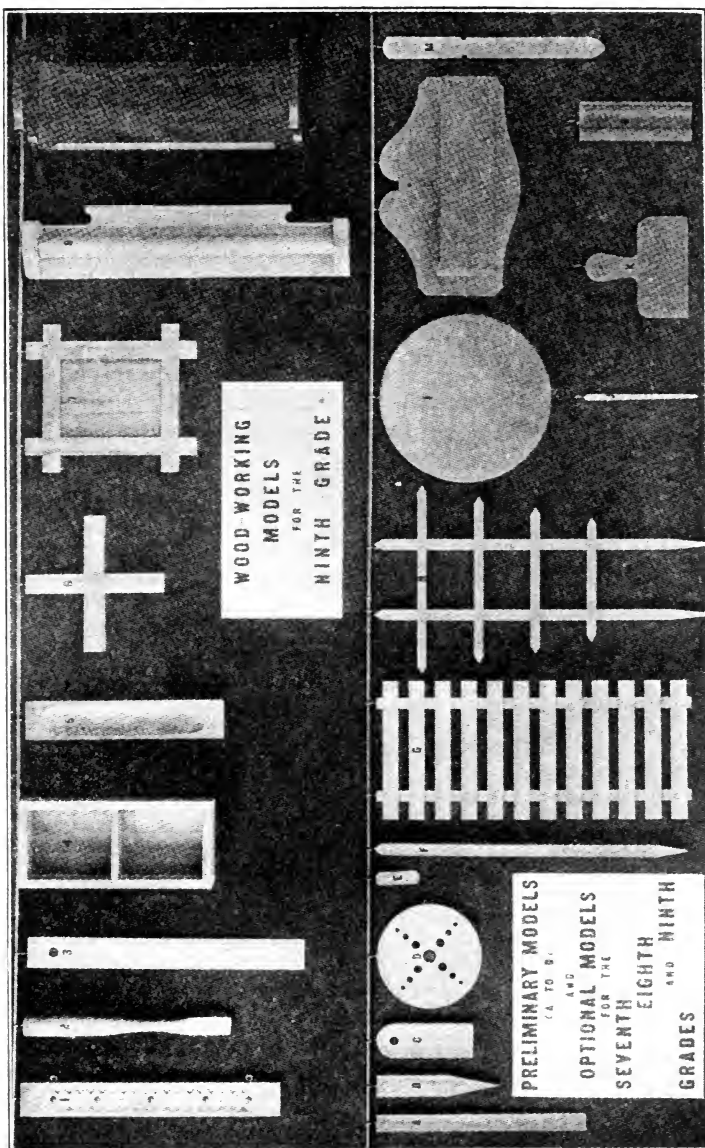

FIG. 128. WOODWORKING COURSE, NINTH GRADE, BOSTON PUBLIC SCHOOLS, 1901

One of the early devices intended to solve this problem was worked out by the writer at the New York College for the Training of Teachers. This was illustrated by an exhibit at the Columbian Exposition in Chicago in 1893, and won the official recognition of the representative of the French Minister of Education. This device was known as the group method of organizing a course of instruction. The subject matter for a given course of manual instruction was divided into natural or convenient groups. Each group consisted of things to make. Each group contained more than any one pupil would be likely to do. Certain elementary and vital parts of these things to make in a given group were designated as required, and the remainder as supplementary. The supplementary part might be indefinite in extent, provided it did not overlap the next or a future group in the course. There might be two required models or exercise pieces in a given group to be made by every pupil in the class, in order that all members of the class should acquire the minimum essentials of the group. In addition to this, there might be three, five, or any number of supplementary problems of varying degrees of difficulty and sufficiently interesting to the pupils to act as an incentive to do more than the minimum work of the group. Class instruction was given on the required part of the group, but only individual instruction was given on the supplementary parts.⁶

Working quite independently, Benjamin F. Eddy, in Boston, worked out a similar device on teaching wood turning. This, too, was shown at the Columbian Exposition. His required work consisted of a series of exercise pieces, and his supplementary work was a series of useful models involving the same cuts and forms as the exercise pieces. (1—164) The required work was after the Russian method, and the supplementary after the Swedish, but the result of this device was superior to that acquired by either alone.

Another similar device for harmonizing class and individual instruction, worked out quite independently of both of these,

⁶A more extended explanation of the group method may be found in Bennett: *The Manual Arts*, Chapter VI.

was the basic factor in the organization of the Danish sloyd, also shown at the Columbian Exposition. (cf. 23)

Among the early friends of manual training, who were also some of its severest critics, were Dr. G. Stanley Hall, president of Clark University, and Colonel Francis W. Parker, principal of Cook County Normal School. Dr. Hall once characterized it as a "hypermethodic" scheme in which the "thought side is feeble." To him it was "wooden in its teachings" and "iron in its rigidity." Courses in manual training were not liberal "because they hardly touch science, which is rapidly becoming the real basis of every industry," he said. Sloyd "in its partly acclimatized forms to American conditions," he considered "all adult and almost scholastic." For such "overmethodized and supernormalized" work, he would substitute toy-making in the lower grades and the making of simple scientific apparatus in the higher grades. "In general," he said, "the whole industrial life of our day is being slowly explored in the quest of new educational elements; and rubber, lead, glass, textiles, metallurgical operations, agriculture, every tool and many machines, etc., are sure to contribute their choicest pedagogical factors to the final result. In every detail, the prime consideration should be the nature and needs of the youthful body and will at each age, their hygiene and fullest development, and next, the closest connection with science at every point should do the same for the intellect." He thought that the Indian industries, such as basketry, pottery, bead work, leather work, and the making of bows and arrows, needed but little systematization to have even greater educational values than the imported sloyd. The same, he thought, would be true of some of the "indigenous household work of the old New England farm." (20—I, 176-179)

Colonel Parker, also, opposed a rigid course of models in the manual training. He pointed out that the process of education is used for two opposite purposes—to establish a hierarchy or to set free the human spirit. "Uniformity is absolute tyranny." "The influence from abroad is all in that direction." "To put down a course of study and say that every teacher shall follow it is tyranny. Manual training is the youngest

child of our educational work. Shall we allow this tyranny to crush it." (21—I, 99)

An early example of an effort to profit by such criticisms as that of Dr. Hall was the work done at the Ethical Cultural Schools in New York City under Arthur W. Richards. In a magazine article on "The Thought Side of Manual Training," published in 1902, he said, "The arts of industry furnish a motive thought and answer, as nothing else, the requirements for a basis for the manual work in our schools; because, more adequately than any other division of human activity, they represent that which has been evolved by the joint efforts of brain and hand." (21—III, 62) He accompanied his statement with illustrations showing the solutions of problems in mechanics and engineering by boys in the elementary schools. These included models of a waterwheel, a windmill, an airship, girders, devices for testing the strength of materials and construction elements, and such things as a mechanical shovel, a power derrick, and a bridge. He described the method of procedure in such problems in this sentence: "The purpose of the project, the function of its parts, and the principle upon which it worked were discussed, leaving the pupil to bring in a plan for the same and work it out as his own business." Then he explains, "It does not represent a gradation and sequence of tool exercises perfect enough for some"; but he considered it the "most gratifying work" he had ever done. He advocated a special library and museum to facilitate such instruction.

Shortly after this, progressive teachers and supervisors in public schools began to introduce such industrial-study problems as part of grammar-grade courses in manual training.

Another criticism that began early and has continued to the present time was that the manual training in schools of all grades was not taking advantage of a great opportunity to correlate with art instruction. No attention was paid to teaching design. The freehand modeling in some of the sloyd models was form study of a rather advanced and difficult type, but it was not design. The adaptation of chip carving to

sloyd models was appropriate surface decoration; but such adaptation was difficult for pupils and sometimes even difficult for teachers, and gave the pupils no design problems suited to their age and experience, though it did help them to add some appropriate decoration to their work in construction.

It was at this stage of development that the term "manual arts" came into use to express emphasis on the art side of manual training. In 1893, this term was used at Teachers College, New York City, to designate a building expressly for art and manual training—the Macy Manual Arts Building. The term was applied also to the new department of the college housed in that building, and very soon was given to the department of work in the New York City public schools presided over by Dr. James Parton Haney. From that time, the term gained in popularity. (21—XXXVI, 233–241)

The urge for design was very greatly stimulated by the Arts and Crafts Movement that took definite shape in this country (cf. 65) with the incorporation of The Society of Arts and Crafts in Boston in the year 1897. This society was organized "for the purpose of promoting artistic work in all branches of handicraft." The society maintained a salesroom and permanent exhibition; held occasional exhibitions that were more extensive; conducted a bureau of information; and for four years, beginning in 1902, issued a choice little monthly magazine called *Handicraft*. The Society issued a statement of principles of handicraft, one of which was as follows:

The conditions of true handicraft are natural aptitude, thorough technical training, and a just appreciation of standards. The unit of labor should be an intelligent man, whose ability is used as a whole and not subdivided for commercial purposes. He should exercise the faculty of design in connection with manual work, and manual work should be part of his training in design. (22—2)

The ideal set forth in the last sentence of this paragraph was at once accepted by many educators as a goal for the manual-training and the art work in the schools. An outstanding example of early efforts in this direction for the elementary schools was some experimental work done in New York City under the supervision of Dr. Haney. Two teachers working

under him taught design by showing type models, or block models, to the pupils and asking them to modify the contour in accordance with their own ideas of what change would make the object more beautiful. (21—IV, 10) By proceeding in this way and discussing with the class the possibilities and limitations of change, good individual designs for bookracks and brackets were produced by the pupils. In addition to modifying contours, the pupils made individual surface designs for their bookracks and brackets and for boxes, plate racks, and the like. These were applied by outlining with a carving tool and then staining and finishing. (23—13—22) For teachers using this method of teaching design along with the construction, Dr. Haney wrote a notable series of four articles entitled "Applied Design." (21—VI, 129—137; 210—221; VII, 1—15; 57—76) Meanwhile Professor Charles R. Richards at Teachers College was developing a course in constructive design intended especially for teachers of manual training. (21—IX, 114—127; 223—234)

Thus individually designed art-craft products began to appear in the school workshops, but some of them were unsuccessful because the teachers in charge of the shop instruction were not adequately trained in design and in teaching by the creative method. Training in both was needed to produce satisfactory educational results. (24—110)

Still another criticism of manual training in the upper grammar grades was that it was more play than work, was isolated from the other school studies, and was lacking in educational value. Not only was it lacking in correlation with art but also with science and mathematics where correlation was easily possible. The essential truth of some of these statements was easy to verify, but the facts were difficult to change. In the first place, manual training began in the high school with a system organized for specific training in hand skill, not for general education. Secondly, most of the teachers of manual training had not been broadly educated and had not attained a professional outlook beyond the technical phases of the subject they were teaching. Even in teaching the related technical subject matter, they were

weak, and had no conception of the possibilities of correlation with other subjects. And, thirdly, the superintendents and principals of schools did not have a clear idea of what ought to be accomplished through manual training, and so could not guide the teachers.

There were exceptions to this rule with reference to both teacher and superintendent. A notable example was at Oak Park, Illinois, where the superintendent, W. H. Hatch, had a clear conception of what manual training should do for the boys of his seventh and eighth grades and where the teacher, Ira S. Griffith, was a literary college graduate as well as a practical carpenter. Mr. Griffith had been a college professor of mathematics before teaching manual training, and continued with graduate work in educational psychology, history of education, and methods of manual instruction. He was an enthusiastic believer in the educational possibilities of manual training, and an understandingly successful teacher of boys. In a very few years, he developed work that attracted nation-wide attention. He assumed "that grammar-grade woodworking has a subject matter" of its own. He believed that in the grammar grades of public schools, "for economic reasons," "classes of considerable size must be cared for." He believed in class instruction and in organizing subject matter so as to make class instruction as effective as possible. In teaching mathematics, he had learned the value of a textbook. He asked for a textbook. As there was no satisfactory one available at that time, he wrote one, *Essentials of Woodworking*. The use of a text, he said, removes the necessity of constant repetition of oral instruction. He believed in holding "the thought element and the element of skill" in proper balance—"the doing growing out of the thinking and the thinking made clear and definite through doing." He considered that both the Russian and Swedish systems had overemphasized the value of skill and that certain psychologists had placed too much emphasis on the value of thought element to the neglect of the value of skill. His constant aim was to give instruction that would balance these two elements. (21—X, 148-160) For problems, he

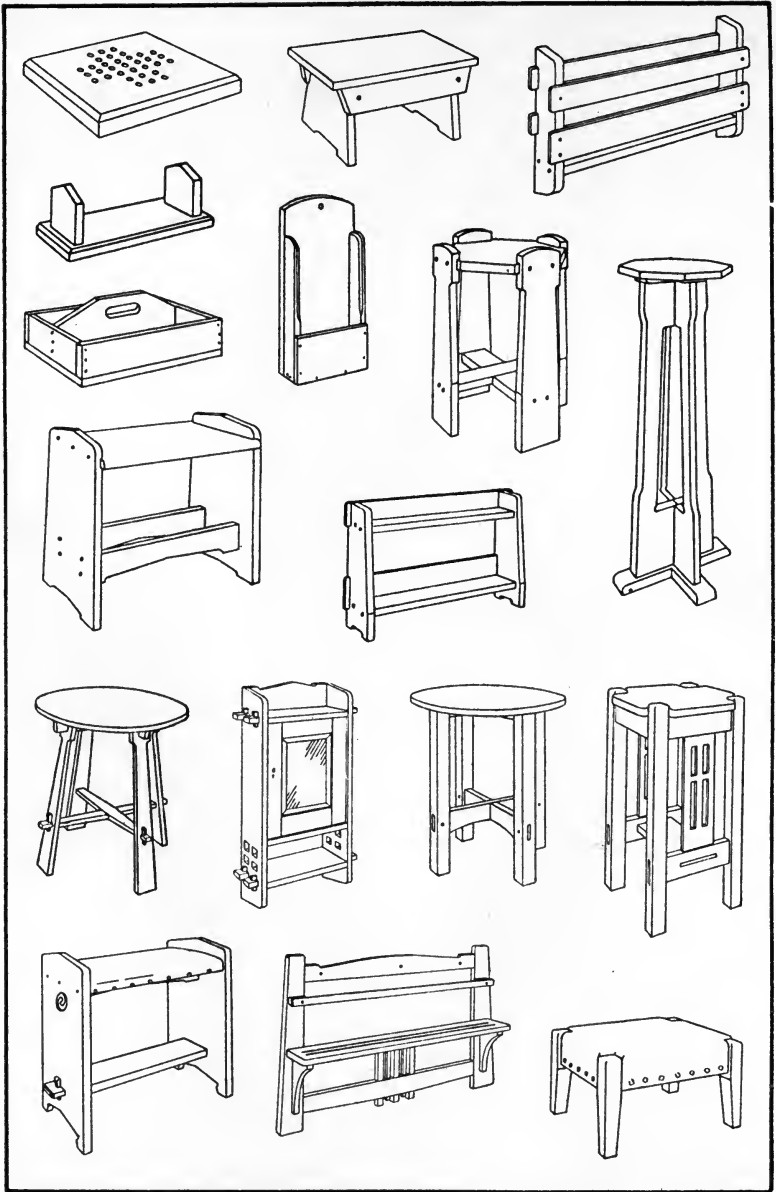

FIG. 129. GRAMMAR-GRADE PROBLEMS DESIGNED OR ADAPTED BY IRA S. GRIFFITH, 1912

selected well-designed small pieces of furniture in harmony with the ideals of that time. Figs. 129 and 130.

He organized his course of instruction by arranging problems in groups. It included the making of working drawings and the study of and reporting on definite related information assignments. After experimenting, he concluded that he could secure the best results in the year's work by having the pupils devote the first twelve weeks entirely to making drawings which they would use during the remainder of the year. (25—34) Care was taken by him to have the pupils work on well-designed objects and to gain a little experience themselves in designing what they made. This included especially the study of proportion and the designing of contours and of surface decoration. (25—41—51) Fig. 131. He convinced many schoolmen that manual training could be correlated with other school studies and could have educational value equal to the best of the others.

While the work in Oak Park was an outstanding example of the type of grammar-grade manual training of 1908 to 1914, it was by no means an isolated one. Many other teachers with similar ideals were successfully answering criticisms and demonstrating the educational value of manual training.

84. Industrial Arts. To understand the significance of the term "industrial arts" as now employed in American schools, one must recall, at least briefly, the development of handwork instruction in the primary and intermediate schools, whether known as manual training or sloyd or manual arts or construction work or handwork, or by any other name.

Already it has been pointed out (cf. 79) that, in New York City, the manual-training development started with the kindergarten. The suggestion for Miss Huntington's kitchen garden came from a kindergarten she visited in 1876, and Dr. Adler's Workingman's School began with a free kindergarten in 1878. Among the leading advocates of the kindergarten at that time was Dr. William T. Harris, then superintendent of public schools in St. Louis, Missouri. He went so far as to contend that the kindergarten furnished the answer to the growing demand for industrial education, so far as the

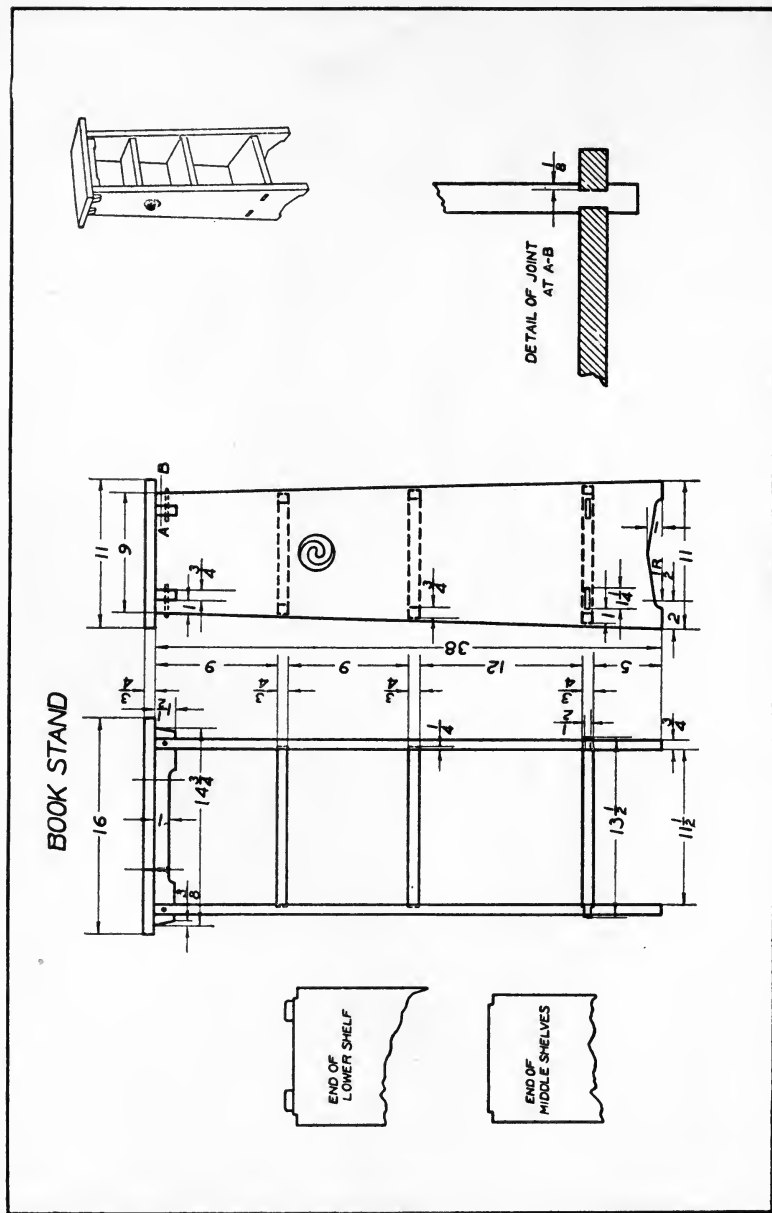

FIG. 130. THE KIND OF WORKING DRAWING ENCOURAGED BY IRA S. GRIFFITH

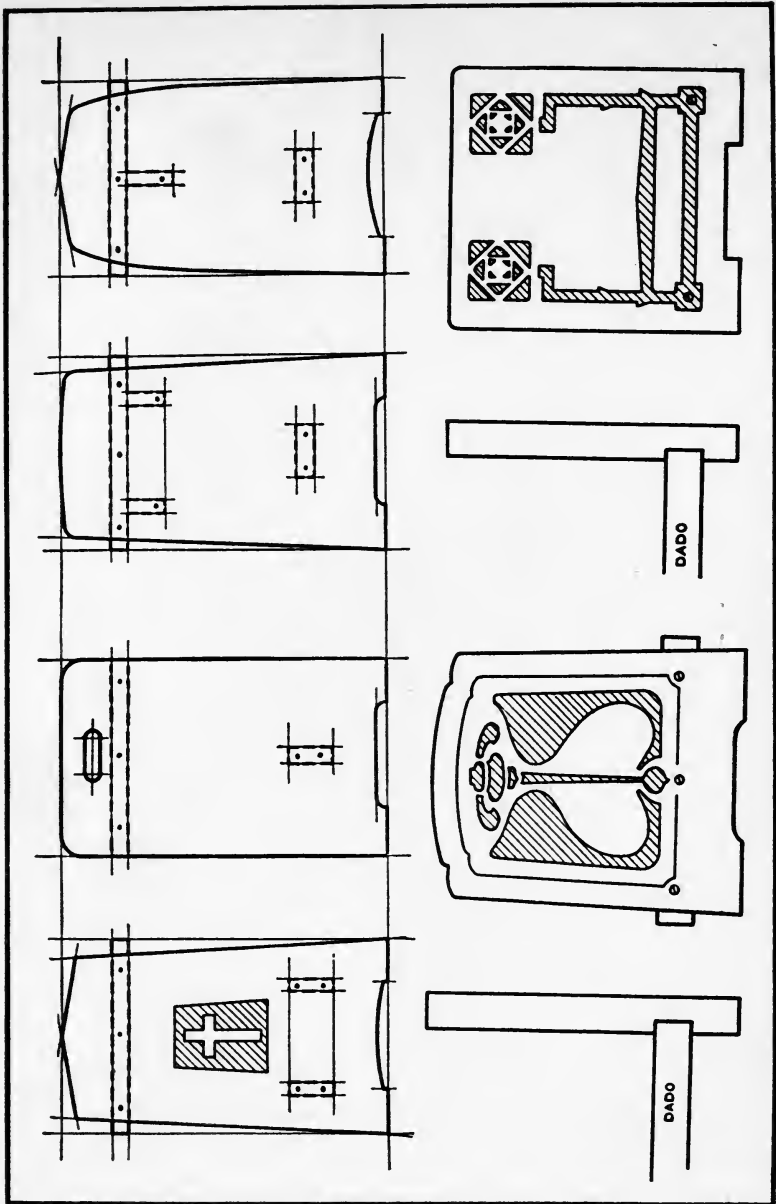

FIG. 131. TYPICAL DESIGN SUGGESTIONS USED BY IRA S. GRIFFITH

elementary school was concerned. In his report for the year ending August 1, 1879, he declared that "the kindergarten gifts are the best instrumentalities ever devised for the purpose of educating young children through self-activity," and emphasized the fact that they cultivated "skill of hand and accuracy of eye." Then he added:

Not only is this training of great importance by reason of the fact that most children must depend largely upon manual skill for their future livelihood; but, from a broader point of view, we must value skill as the great potency which is emancipating the human race from drudgery by the aid of machinery. (26—134)

He considered that the kindergarten was "worthy of a place in the common school system."

It should be a sort of subprimary education, and receive the pupil at the age of four or four and a half years, and hold him until he completes his sixth year. By this means, we gain the child for one or two years when he is good for nothing else but education, and not of much value even for education of the school as it is and has been. The disciplines of reading and writing, geography and arithmetic, as taught in the ordinary primary school, are beyond the powers of the average child not yet entered upon his seventh year. And beyond the seventh year, the time of the child is too valuable to use it for other than general disciplines—reading, writing, arithmetic, etc., and drawing. He must not take up his school time for learning a handicraft.

The kindergarten utilizes a period of the child's life for preparation for the arts and trades, without robbing the school of a portion of its needed time. (26—135)

This and similar statements by Dr. Harris gave strength to the Kindergarten Movement, but they did not please some teachers and school officers who were desirous of taking regular school time to experiment with the kindergarten gifts and occupations and with other forms of handwork.

As stated earlier in this chapter, a very early course in handwork for the elementary-school grades was formulated by Samuel G. Love and Mary R. Willard at Jamestown, New York, and published in 1887. Nearly all of the work up to the seventh grade was the formalized work of the kindergarten, or other handwork organized in the same spirit. It was kindergarten work extended upward into the grades, plus a first lesson in each type of work—an object lesson—that was

given in the Pestalozzian manner then in vogue, especially at the Oswego Normal School.

During the next few years, there was a definite swing toward such superkindergarten instruction in the primary grades, and during that same period a rapid extension of the teaching of "form study and drawing" by highly formalized systems (especially by the "Prang system") under the supervision of special teachers of drawing.

During this same period also, courses in thin woodwork were developed by many teachers of manual training, as they said, "to bridge the gap between the kindergarten work of the primary-school grades and the manual training of the seventh and eighth grades." One of the very first of these was worked out by George B. Kilbon of Springfield, Massachusetts, and published under the title, *Knifework in the Schoolroom*, in 1891. This consisted chiefly of exercise pieces and geometric figures. Another course made up of useful models was well developed by Eli Pickwick, Jr., in St. Paul, Minnesota. There were many others. (27—31—39)

What was, in some respects, a new type of work for the intermediate grades appeared in 1899, when *Cardboard Construction* by J. H. Trybom was published. This was an American adaptation of the cardboard sloyd of Sweden. It was a course of models, each represented in the book by a working drawing, a pencil sketch of the completed object and, briefly stated, the procedure in construction. Each model had some use or represented something useful. This type of work was more technical in character than the kindergarten type or the form study type of work; it appealed to children; under special supervision, it could be taught by the regular teachers of the intermediate grades; it was practical under school conditions. During the next twelve years, no less than eight more or less similar courses were published in book form, and others appeared in school reports and pamphlets.

A general characteristic of these courses was that, in organization, they were formal courses based on a sequence of some sort—usually a sequence of difficulty in making. They

were true descendants of Froebel—some by way of sloyd inheritance and some direct from the kindergarten. They were therefore subject to the same teaching strength and the same kinds of weaknesses as the kindergarten. As soon therefore as the kindergarten became the subject of severe criticism, such courses and similar courses in other materials began to suffer.

At a meeting of the National Education Association held in 1890, Anna E. Bryan of Louisville, Kentucky, read a paper before the kindergarten section that is now recognized as a turning point in the history of the kindergarten in America. The title of the paper was "The Letter Killeth." It was an outcry against the formalism of Froebel's system that had been made more formal in many American kindergartens—an outcry against "becoming so fascinated by the tools as to study them more than the child."

To suppose that simply giving to the child a sequence of material will necessarily lead to a sequence of creative thought, is the root difficulty in the use of Froebel's school of work.

This illustrates a mechanical and empty use of sequence. It is the letter without the spirit. . . . In order to give sequence in reality, there should pass through consciousness *not* a *passive, literal* sequence, but an *active, creative* one. (28—575)

From such a starting point, the leaders in kindergarten instruction, assisted by John Dewey, Fig. 132, G. Stanley Hall, and others, have developed the modern progressive kindergarten; and this change was felt higher up in the school grades.

About the same time that reaction against excessive formalism in kindergarten instruction began, Herbartian methods were brought to this country by American teachers who had studied at the University of Jena. Leaders in this movement who followed closely the teachings of Herbart looked upon manual instruction, not as a school subject, but as a convenient and effective means of teaching the traditional subjects of the school.⁷ For this purpose, the sequential courses built on the Froebel plan were not needed. The

⁷ Bennett: *History of Manual and Industrial Education up to 1870*, p. 161.

sequence of manipulative processes of the manual work must give way, they maintained, to the needs of the subject to which it was ancillary. The sequence must be of a different character, determined by other subjects—arithmetic, or science, or history, or language instruction. The bewilder-



FIG. 132. JOHN DEWEY

ment that followed in the trail of these leaders can be imagined.

Then came John Dewey's *School and Society* in 1899, placing industrial occupations at the very center of the elementary school curriculum. He, too, accepted the idea that manual training in the lower grades of the elementary school, at least, should be regarded as a method of teaching—

as a means of teaching related subject matter—but in these grades he would make the industrial occupations so broad and rich in related content that they would very readily and naturally become the basis for instruction in the so-called other subjects. Moreover, he would not select occupations that were merely typical of adult life, but occupations that were real in school life. They should serve as “instrumentalities through which the school itself shall be made a genuine form of active community life, instead of a place set apart in which to learn lessons.” (29—23) In the *Elementary School Record* for December, 1900, he said:

The more direct modes of activity, constructive, and occupation work, scientific observation, experimentation, etc., present plenty of opportunities and occasions for the necessary use of reading, writing (and spelling), and number work. These things may be introduced, then, not as isolated studies but as organic outgrowths of the child's experience. (30—231)

Concerning this organic outgrowth he said:

“It is the community and continuity of the subject matter that organizes, that correlates; correlation is not through devices of instruction which the teacher employs in tying together things in themselves disconnected.” (30—14)

Such statements as these and the methods of instruction being employed at the University Elementary School in Chicago brought his philosophy of education almost immediately to the attention of every forward-looking schoolman. Among the men in the manual-arts field, no one of the leaders was quicker to react to it than Professor Charles R. Richards, then director of the department of manual training at Teachers College, Columbia University. In 1901, he addressed the general session of the National Education Association on “Handwork in the Elementary School.” His address was, in fact, a discussion of the application of the Dewey philosophy to the manual education of the primary grades. In this he said:

The problem of the elementary school today is, I conceive, to make the life of the school more real; more an epitome of the kind of thinking, feeling, and doing that obtains in real life; more a reflection of the actual life outside of the school walls. . . .

But handwork will not be a life element in the school, unless it is used in a natural way. . . .

When we take up the problem of handwork in this spirit, we are going to recognize that a nice sequence of difficulties in the work may be of less importance than the question of motive or the significance of a project to the real interests of the particular moment. Accuracy and precision have commonly been referred to as the essential qualities of all educative handwork, but accuracy is natural only when its necessity is appreciated by the worker, and this will be the case only to the degree that the need for accuracy is perceived to be an inherent condition of success in the task and not as a quality imposed from without.

Such natural expression through handwork cannot take the form of set courses. It must be a matter of adaptation and relation to the life of each particular school. Both the in-school and out-of-school interests of the particular children dealt with must form the basis for such work. This means infinite variety and flexibility. Handwork of such a kind will take as many forms as there are classes to be taught and teachers to teach them.

In relation to the school interests, or more specifically to the course of study, handwork represents emphatically a method rather than subject matter of instruction; and it is in this sense that such work finds its most natural place in the lower grades. . . .

On the side of the pupil, handwork is a medium of expression in terms of form, color, and material; in its relation to social life, it is essentially a means of interpreting art and industry. (21—III, 2-9)

These statements are indicative of the definite reaction against the organization of sequential courses of instruction in handwork for the primary grades that came with the acceptance of the social philosophy of John Dewey.

Not long after this, in October 1904, Professor Richards, in an editorial in the *Manual Training Magazine*, suggested that the term "industrial arts" be substituted for the term manual training. ~~He contended~~ that, owing to a change of viewpoint, "we are rapidly leaving behind the purely disciplinary thought of manual training. . . . Now we are beginning to see that the scope of this work is nothing short of the elements of the industries fundamental to modern civilization." (21—VI, 32, 33)

In 1913, Frederick G. Bonser, professor of education at Teachers College, Columbia University, contributed an article to the *School Arts Magazine* that expanded the conception of industrial arts in the elementary school. It considered it as both a subject and a method—an end and a means.

Accepting the social philosophy of Dewey, Bonser sought to help in reforming elementary education. In doing so, he made full use of industrial arts. He asserted that industrial arts, when considered as a school subject, must justify itself on the same basis as other subjects. Then he added:

From this standpoint, it will at once appear that primary emphasis will not be placed upon the production of industrial commodities, but rather upon intelligence and cultivated taste in their choice and use. In no single field will all of the children function as producers, but from every field worthy of study they will all function as consumers. The largest problems are those of developing an appreciative understanding of industry as it is at the present time, realizing its social problems and cultivating intelligent judgment and appreciation in the selection and use of industrial products.

To illustrate Bonser's expansive view of only one of the industrial arts, the following is quoted:

A study of the making of books is not primarily to produce skill or craftsmanship in bookmaking—few, if any, of the children in a given school will become bookbinders, and, if any of them do, it will probably not be handicraft bookbinding. The purpose is rather to develop insight into an industry whereby the race has put itself on record for untold generations, improving its means and methods step by step, until the great mechanical typesetting machines are subjects of study and understanding; to study the design involved in the choice and arrangement of type, the arrangement of the page, the choice of paper, the design of binding and cover pages, and the appropriateness of all to the author's thought and feeling with the form and dress the bookmaker has given it; to learn of the debt we owe to Gutenberg, Coster, and Caxton, and, perhaps, to enjoy a part of "Fust and His Friends" with Browning, and to push on for a little way into social and even political questions—the great army of laborers engaged in the printing and publishing industry, wood pulps, and tariffs, and the place of the press in business, education, and enjoyment. The historic aspects of the work may lead a long way back to notch sticks, obelisks, tablet and stylus, papyrus, parchment, scroll, primitive inks, and quill pens, the monk and the scriptorium, rare illuminated texts, wood-block printing, and coming nearer and nearer to the present, to movable metal type, the linotype, the monotype, etchings, steel engravings, lithographs, electrotyping, and all of the marvelous possibilities of printing in form and color of today. In this study, many masterpieces of painting will help to give correct ideas of numerous elements in the bookmaker's art, and the historic summary will doubtless include the appreciation and enjoyment of Alexander's "Story of the Book" from the Congressional Library at Washington. Many of these problems will include handwork involving design and the use of the appropriate materials in such a way as to clarify thought and at the same time to secure all of the possible development of sense training and manual dexterity, and in every case in relationship to a specific situation appreciated as valuable. The work will

involve the study of man's many books, new and old, of current magazines and other periodicals, of streetcar, billboard, and other forms of poster advertising, and of printed matter wherever found. Is there not here a subject matter which will make books and the great art of their making mean vastly more than is usual—which will develop permanent interests in books, and which will cultivate judgment and taste in the selection of books in all particulars of form? Compare this body of thought, experience, and activity with the usual course in paper folding, cardboard construction, and book-binding to see wherein the difference lies. (31—109)

As to methods of procedure in teaching, Bonser would follow that by which we learn in life. A given experience may be made up of a variety of things, involving, perhaps, arithmetic, geography, spelling, science, and industrial arts. Let the child have the same kind of experience in school life. Proceeding thus, there is no need for overformalized courses of models in theoretical sequence. Instead, there should be "problematic situations." "The experiences of the race which have been and are fundamental to the race, constitute the *subject matter* and *content* of education. The process of re-living these race experiences, through meeting them as problems to be solved much as the race has solved them, constitutes the *method* of education." (31—187)

While the term "industrial arts" was first used to designate work that developed as a reaction against the formalized courses inherited from Froebel, the term has become so popular in the United States of America that it is coming to include all instruction in handicrafts for general education purposes, whether formalized or not. Its meaning is essentially the same as the term "manual arts," though its connotations are different. In the term industrial arts, the "industrial" is emphasized; while, in manual arts, the "arts" is historically the distinctive word and, in the term manual training, "manual" is the important word.

SOURCE MATERIAL XI, A

HAND EDUCATION AS AN ESSENTIAL PART OF SCHOOL EDUCATION

From an Address Concerning the Workingman's School, Delivered
before the Society of Ethical Culture, New York City,
October 24, 1880, by Dr. Felix Adler

But there is one main direction in which we believe we have to offer what is essentially new and what will constitute an epoch in education, if it be generally accepted. We mean the inclusion of hand education as an essential part of school education. I take it here for granted that free, popular education ought to be especially adapted for the children of the poorer classes, who are not able to provide the education suitable for their offspring themselves; for the children of the working people, who will be in their turn the working people of the future. I take it that public education ought especially to fit such children for their future station in life. And it is this class, whose needs appeal to the sympathy of the more fortunate, that we have had particularly in view in attempting to build up a model school. Now, if there is any one thing which the working people need, and which, therefore, the common welfare demands—for the interests of the community at large and of the working people are most intimately bound up together—it is that *greater dignity* shall attach to hand labor. There is no kind of work that does not become attractive when dignity attaches to it. Work of the hardest kind is performed every day by men of science, work which involves personal discomfort and the overcoming of physical disgust, and yet it is cheerfully done because of the intellectual dignity that elevates such work. Every physician renders, in his practice, menial and repulsive services, which no servant could be hired to render; and the physician, far from being disgraced, is ennobled by his service. In the same way, we believe that the tedious work of the working people could be rendered more easy to them, and even elevating, if greater dignity could be made to attach to it; if only more intellect could be put into it. And we look to hand education in the school as a means of accomplishing this desirable object. There are certain mental operations that underlie manual operations. These the children should be taught, so that their manual operations may become transparent to the mental operations that underlie them. In modern times, capable men have discovered that there is such a thing as a theory of tools; that tools can be classified and grouped, and that a child's mind can be led along in orderly succession in learning them. It has been shown that there are three great types of tools, involving three principles, by which, and the combinations of these principles, every kind of tool can be explained. There are reasons underlying manipulation; there is a reason why an axe should be wielded in a particular way, why an axe splits, and why a knife cuts wood. The double-cutting edge of a plane exhibits a rational contrivance, and has an interesting explanation of its own. The children ought to be taught these reasons, and made to understand these explanations, even while they use the saw, and wield the axe, and strike with the hammer, and move to and fro the plane. . . .

RUSSIAN SYSTEM OF INDUSTRIAL TRAINING

Later on, in a higher stage of industrial education, what is called the Russian system comes into play. The novelty and the importance of this system is that it is developed in a graded series of workshops, designed to serve educational purposes only; that the products of the young workman's labor are not salable articles, but in all cases typical forms, intended solely for the purpose of manual instruction. In each of these educational workshops, there is a particular class of learners, and there are elementary lessons for the use of beginners in the school, and advanced lessons for the more advanced; and, in each of these workshops, the use of one set of tools only is taught, and the pupil remains in this one workshop until he has mastered the theory and practice of this one set of tools. He is then graduated into a higher workshop, until he has finished the whole course; and he learns how to work in wood, and learns metal turning, and fitting, and planing, and forging. And some of the coarsest and some of the most repugnant kinds of labor are thus made interesting, and redeemed from their coarseness, because they are now saturated with understanding. The labor of the hands becomes attractive, because it blooms with mind.

If the machine be regarded as a development of the tool; then, in the same manner as he who works with tools is taught the principles underlying the use of tools, the ordinary factory workman also, who spends his days among machines, ought to learn to understand the principles embodied in machines. Enough of physics and mechanics must be taught in the school to attain at least this end.

IMPORTANCE OF EARLY BEGINNING

Now, furthermore: I believe that work education can be given to the youngest children, in the lowest classes of the school. And here is perhaps the main point, in which the importance of what we consider to be our new departure in education becomes apparent. For industrial education has long ago been given in many countries of the world to older children—boys of fifteen or sixteen years of age; but industrial education has never, to our knowledge, been introduced in the lower classes of schools; has never been combined *organically with the whole scheme of education*, and been made to support and coalesce with all the other studies of the child. And there are other ways, assuredly, which must occur to everybody, in which industrial education will tend to elevate the workman. It will develop his aesthetic sense, giving him something of the *artist's pleasure* in his work, giving him also greater *skill*, and thus enabling him to command *higher wages* and more of the comforts of life. But it is with industrial education as a means of fostering the dignity and independence of the workman that we are mainly concerned. For, upon the possession of these qualities, it will depend whether the social inequalities that exist between the working people and other classes of society will be gradually ameliorated, or so long as they must exist, will be endured in the right spirit. . . .

Let us impress upon the minds of the children that the business of life will always be carried on in a hierarchy of services, and that there is no shame

in doing a lesser service in this hierarchy; that all honor accrues to us only in doing that function well to which we are committed, and taking pride and finding dignity in its performance. And to enable the working people of the future to take pride and find dignity in the work of their hands, is the object of the work education which we are seeking to introduce into our school. I do not say that the young are to be taught to consider the present hierarchy of services as arranged upon a just or fair plan; I do not say nor should I teach that those are now in the higher grades of society who ought to be, and those in the lower who belong there. The reverse is often true. But, if a change in the interest of righteousness is to be made, it must surely come mainly from the working people themselves. It is their heightened self-respect, it is their increased intellectuality, it is their sense of dignity as working people, which will alone enable them to accomplish the wished-for result. . . .

INDUSTRIAL TRAINING ADDS INTEREST TO LIFE

And so there can be nothing more salutary, nothing more wholesome, nothing more efficient for good, than a system of work education, which shall relieve industry of its deadness and its dullness, and give to the laborers the reasons why of those occupations with which they are daily concerned.

We lend, moreover, an entirely new import to the method of industrial education in the school. We are seeking to apply the principle which ought to be at the foundation of every modern scheme of education: namely, that, as experiment conjoined with observation is necessary to the discovery of truth, so object-creating must supplement object-teaching in that rediscovery of truths which it is the purpose of all education to facilitate. Therefore, work instruction is not a something outside the regular instruction; it is an organic part of the regular instruction. It becomes a means of teaching mathematics, for instance, more thoroughly, causing the pupils to work out mathematical truths with their very hands; it becomes the means of teaching natural history more effectively; it is worked into inseparable connection with the entire scheme of the scholar's mental and moral development. It becomes the means of making the hand a wise and cunning hand, by putting more brain into it. But, on the other hand, it also makes the brain a clear and vigorous and enlightened brain, by giving it the salutary corrective of the demonstrations of the hand. And so the system of work education, considered as an advance in education, generally has a value of its own. . . .

THE IDEAL OF THE NEW EDUCATION PORTRAYED

And here it may become apparent why our school is not an industrial school in the sense which commonly attaches to that name. We shun the name, and call ours the Workingman's School, because we wish to keep away from us the ideas that are associated so frequently with the name of industrial schools. We do not propose to give our pupils an aptitude for any particular trade; we do not propose to make them tailors, or shoemakers, or printers. We would consider that a retrograde step, rather than a step in advance, if we were to prevent these young lads and little girls from

spending even a few years in gaining knowledge, without any reference to the pitiable necessities of their after-lives; we do not propose to yoke their young souls before they have had time to expand at all into the harness of trade, merely for the sake of getting their bread better afterward. We propose to give them that which will secure them bread thereafter, and many of the higher treasures of human existence, we hope, besides; we propose to give them a broad and generous education, such as children of the richest might be glad in some respects to share with them, which will not only prepare them for their future station in life, but also make them capable of living in a truly human way; we propose, in one word, to educate our pupils so that they shall become not working drudges, not working slaves in the treadmill of labor; but so that, while they remain *working* men and *working* women, they may also be, in the best and noblest sense, *working men* and *working women*. (2—II, 475-479)

SOURCE MATERIAL XI, B

MANUAL TRAINING IN THE COMMON SCHOOLS

From *Special Report of a Committee of the Board of Education in Massachusetts*, Forty-sixth Annual Report of the Secretary, 1881-82

The Committee appointed by the Board of Education to consider and report upon the subject of industrial education in common schools, would beg leave to report as follows:

The subject of industrial education in common schools has been for some time under public discussion. References may be found to it in several annual reports by the secretary of the Board of Education; and several carefully prepared papers have appeared in the appendices to the reports of the Board. It is the opinion of your Committee that the time has come when the subject should receive more specific attention from the Board itself.

It is a question, at the outset, whether the very word "industrial education" is not a misnomer as regards anything that can reasonably be proposed for public schools. The express object of these institutions is such a general training as may prepare for any occupation. This applies to every study in our common schools at least. If it be said that the high schools afford a special training, because they fit for college or because they teach book-keeping, it may justly be answered that even bookkeeping as there taught is only a branch of arithmetic, not carried beyond a point that will be useful in almost any pursuit; and that the college itself, as distinct from professional schools, claims to afford only a general training. But even, if it be granted that the high school affords a special training, and that special training in other ways may be desired by some pupils who are designed for particular pursuits, the legislature has sufficiently provided for that view of the case by allowing each town or city to establish technical schools for itself, in which "arts, trades, and occupations" may be taught. Pub. Stat., chap. 44, sect. 8.

But the real question is not of industrial schools or of technical schools.

We are satisfied that the object of our common schools, as they now are and should be conducted, is to give a general preparation for the duties of life without reference to any particular vocation. Up to a certain point, they answer that demand fairly well. Many of the published criticisms on them are, in our opinion, without foundation. It is not the fault of the common schools that the habit of mechanical apprenticeship is dying out, or that people like to live in the city rather than in the country; or that young men and women prefer the lighter and more lucrative occupations to the heavier and more cheaply paid. These tendencies, whether they are for good or evil, are the tendencies of the time; and our common schools have very little to do with them. On the other hand, the great activity of the community, its business skill and its inventive genius, are directly traceable in a large measure to the intellectual stimulus given by the common school. The evil tendencies that exist are in spite of our school system, not by reason of it; and those evils cannot, in our opinion, be reached, except in a very indirect and remote way, by industrial or technical training in our schools.

But let us approach the matter from a wholly different direction. It is, we take it, the object of our common schools to give to the poorest and least-favored children the same general preliminary education that we should all wish for our own sons and daughters. What should that education include? It would include, if we are wise, not only what is now taught in our public schools, but something more. That something more is something which many wise parents, at least in cities and towns, are now forced to supply out of their private means for their children—the rudimentary training of hand as well as eye. To learn how to drive a nail straight, how to insert a screw neatly, how to fit two edges of plank together, how to make a square box, is to obtain an elementary education almost as essential as to know that two and two make four. It is really the principle of two and two, worked out with the hand as well as the brain; it is to abstract knowledge what geometry is to algebra. It is not necessary to carry it very far, or to apply it in a variety of forms. A little of it goes a great way; but that little is so important that early education is very defective without it. It is not enough to “pick it up.” A boy of natural mechanical aptitude will pick it up in his father’s workshop or in a boat-builder’s shop. But most boys have access to no such place; and, if they had, there is no one to teach them to do it carefully; and, moreover, the boys who have least mechanical aptitude are those who most need such training. Any man who can remember the delight with which he first learned to do neatly and accurately any simple thing with his hands—learned from a sailor to tie a knot, or from a farmer to turn a furrow—ought to recognize the value of making it a part of every child’s training; not to do those particular things, but to use his ten fingers carefully and methodically, in the simplest, cheapest, and most convenient way. This is not industrial education. Industrial education is too large a name for it. It embraces the elements of manual training; that is all.

It is precisely on this point that great light has at last been thrown by European example. Until lately, there has come to our knowledge no attempt in this direction, in any country, which has seemed of any particular value as an example for us. We have heard of class schools, or technical schools, or schools that prepare for particular occupations—as that for

watchmaking at Geneva, Switzerland. These teach nothing toward our end, which is not, as has been said, industrial training proper, but manual training given for its educational value. But a flood of light has just been shed upon the subject by the report of Professor Ordway of the Institute of Technology in regard to manual instructions in the common schools of Sweden. . . .

The essential features of the Swedish plan are these: In Stockholm, a city of about 150,000 inhabitants, every grammar school has now a room fitted up for joiner's work, in which each boy is taught for two or more hours in every week the rudiments of joinery. This trade was deliberately selected, after maturer consideration, as being the simplest, the cheapest, and the cleanest. The teaching is by special teachers, but the plan is there, as with drawing and gymnastics among ourselves, that the regular teachers shall ultimately be trained to supply the place of those especially employed. For this purpose, a normal school for such teachers has been established by private benevolence, the particulars in regard to which will be found in Mr. Ordway's report.

How does this method work in Stockholm? It seems to be the unanimous testimony that it works admirably. Parents who were not at first favorable to it, as adding one more study, have been converted to it by finding their boys much more "handy" than before; and it has so increased the attractions of the public schools that the private schools are now obliged to introduce similar methods. If it be said that some of this attractiveness is due to novelty, it must be remembered that the first introduction of the system into Sweden was in 1872; that it has been practiced in a large part of the city of Stockholm for five years, and through the whole city for two years. This certainly gives time for the novelty to have worn off. Meanwhile, the system is steadily spreading through the whole of Sweden, not being compulsory by any general law, but encouraged by government grants and by gifts from mechanic institutes.

Your Committee are unanimous in the opinion that an experiment so prolonged and so successful as this throws a new light on the whole practical problem. . . . But that our schools need some further development in this direction is to our minds clear; and we do not hesitate to avow the opinion that it would afford a better general training to our children if we would curtail several hours a week from the time now given to unnecessary problems in arithmetic and to learning the names of villages in Siberia, if by this means we can teach every child a little of that manual facility which is the A B C of all the arts and industries of the world. This is the way in which every thoughtful man would reason as to the training of his own girls and boys; and why should he not reason in the same way in regard to the children of his neighbors?

The fact that even on a small scale such instruction has succeeded so well in the Dwight School in Boston, whose reports we also publish in our appendix; the fact that the mayor of one of our great manufacturing cities (Worcester) has expressed in his inaugural address the demand of the people for some such system: these and many other considerations indicate that the time has come for the serious study of the question. To all who are interested in that study, we recommend the report of Professor Ordway as

giving information more valuable for our American needs than all else that has hitherto been written on the subject.

THOMAS WENTWORTH HIGGINSON
FRANCIS A. WALKER
A. P. STONE
ABBY W. MAY,

Committee

(17—155 to 169)

SOURCE REFERENCES

1. *Report of the Commission Appointed to Investigate the Existing Systems of Manual Training and Industrial Education*, State of Massachusetts, 1893.
2. Clarke, Isaac Edwards. *Art and Industry*. U. S. Bureau of Education, 1885-1898.
3. Chaney, George L. *A Letter on Industrial Education* in the Report of Committee on Education made to the Massachusetts House of Representatives, January, 1877.
4. *Forty-First Annual Report of the Massachusetts Board of Education*, 1876-77.
5. *Wood-Working Tools: How to Use Them*. D. C. Heath & Co., Boston, 1896.
6. *Report on a Developing School and School-Shops*. American Social Science Association, Boston, 1877.
7. *Industrial Education in the United States*. Special report prepared by the U. S. Bureau of Education, 1883.
8. Graham, Abbie. *Grace H. Dodge, Merchant of Dreams*. The Womans Press, New York, 1926.
9. Catalogue, *Children's Industrial Exposition*. Cosmopolitan Hall, New York City, 1886.
10. *Manual Training in Common Schools*. Report of the Committee on Course of Study and School Books of the Board of Education of the City of New York, 1887.
11. *Manual Training Course of Study and Teachers' Manual*. Board of Education of the City of New York, 1888.
12. *Eighth Annual Report of the U. S. Commissioner of Labor, 1892*. Washington, 1893.
13. Love, Samuel G. *Industrial Education*. E. L. Kellogg & Co., New York, 1887.
14. *Sixty-second Annual Report of the Board of Public Education*, City of Philadelphia, 1881.
15. Pennel, Elizabeth Robins. *Charles Godfrey Leland, A Biography*. Houghton Mifflin and Company, Boston, 1906.
16. *Report of the Commission on Industrial Education* made to the Legislature of Pennsylvania, 1891.
17. *Forty-sixth Annual Report of the Massachusetts Board of Education*, 1881-82.

18. Larsson, Gustaf. *Sloyd*. Sloyd Training School, Boston, Massachusetts.
19. Annual Report of the Committee on Manual Training, School Document No. 12, 1904, Boston.
20. Hall, G. Stanley. *Adolescence*. (2 vols.) D. Appleton and Company, New York, 1904.
21. *Manual Training Magazine*, The Manual Arts Press, Peoria, Illinois.
22. Annual Report and By-laws, The Society of Arts and Crafts, Boston, 1904.
23. Yearbook of the Council of Supervisors of the Manual Arts, 1905.
24. Bennett, Charles A. *The Manual Arts*. The Manual Arts Press, Peoria, Ill., 1917.
25. Griffith, Ira S. *Correlated Courses in Woodwork and Mechanical Drawing*. The Manual Arts Press, 1912.
26. Twenty-fifth Annual Report of the Board of Directors of the St. Louis Public Schools for the year ending August 1, 1879.
27. Teachers College Bulletin, No. 6, March, 1896. Teachers College, New York.
28. Journal of Proceedings and Addresses, National Education Association, 1890.
29. Dewey, John. *The School and Society*. The University of Chicago Press, 1899.
30. *The Elementary School Record*. A series of nine monographs, The University of Chicago Press, 1900.
31. Bonser, Frederick Gordon. *Life Needs and Education*. Teachers College, Columbia University, 1932.

CHAPTER XII

TEACHER TRAINING AND ASSOCIATIONS OF TEACHERS

85. Beginnings of Manual Training in Normal Schools.

In looking for early instruction in manual training in normal schools, one turns first to the Oswego State Normal School, the institution that received its great inspiration from the teachings and work of Pestalozzi, who has been called "the father of manual training." This school, organized by Edward A. Sheldon (1823-1897), superintendent of schools in Oswego in 1861, was first known as the Oswego Training School. Five years later, it became a State normal school. From the early days of this school, such handwork as "stick laying, weaving, paper cutting, color, form, and inventive drawing" were included among the school activities.¹ About 1880, "a crude shop was fitted up in the basement" of the school building "where students could go and make pieces of apparatus and illustrative material" with the help of the janitor, Frederick H. Cyrenius, who was a good mechanic. "The work was purely voluntary on the part of the student. No regular class was established until 1893. However, much work was accomplished by Mr. Cyrenius in the making of school apparatus with the students."²

As early as 1881, "an industrial laboratory for wood-working" was in operation at the State Normal School at Bridgewater, Massachusetts. One of the regular instructors of the school was the teacher in this department. (1-126) The instruction was closely related to the work in science, yet it was based on a teaching analysis of materials, tools, and processes. The detailed outline of the Bridgewater course, reported in 1893 by Principal A. G. Boyden, is accompanied

¹From a manuscript accompanying a letter from Dr. Joseph C. Park, dated September 27, 1935.

²Ibid.

by the following paragraphs which suggest the method and spirit of the instruction:

It will be noticed that the pupil starts with a distinct idea of something which he needs for his own use, and is stimulated in his work by the desire to supply this need. He learns the nature of the materials which he uses, and how to use tools, so that he is able to go on and make for himself other apparatus as he may desire.

The benefits of this training are noticeable in all the lines of school work. Students have better command of themselves in any work which requires the use of the hands, and consequently greater interest in their work. It induces accuracy and skill. (1—133)

Some of the things made in this course were insect boards, test-tube holder, botany press, box for insect collection, mineral cabinet, and specific gravity apparatus. (1—131—133)

In 1883, instruction in the use of woodworking tools was begun at the State Normal School at Whitewater, Wisconsin. It was considered "a valuable adjunct of the scientific department." (2—398) In that same year, the Cook County Normal School, under Colonel Francis W. Parker, began to teach "sloyd, clay, and pasteboard . . . correlated with other work." (3—chart) In 1884, manual-training instruction was begun at the State Normal Training School in New Britain, Connecticut; in 1890, at the State Normal School, San Jose, California; and, in 1891, at the State Normal and Model School, Trenton, New Jersey.

As a member of the Industrial Education Commission of Pennsylvania, in 1888 or 1889, Dr. N. C. Schaeffer gathered facts about the State normal schools of the nation. Concerning such schools in twenty of the most progressive states, he said in his report:

Manual training has received very little attention in the normal schools of these states. The Maryland Normal School teaches woodwork to the young men and cooking and sewing to the young women. The Prairie View Normal School in Texas began this year with work in wood and metals and with sewing and cooking for girls—appropriation, \$5,000. The schools at Whitewater and Milwaukee in Wisconsin have a shop department in which pupils are trained in the use and care of common tools, and general principles relating to the construction of simple forms of woodwork, in lathe and forge work.

A large part of the students are females from sixteen to twenty-five years of age. They learn to handle hammer, saw, square, auger bit, plane, chisel, forge, lathe, etc., making various articles of furniture, apparatus, involving varied forms of joints, mortises, tenons, etc.

For several years, the pupils (ladies) of the State Normal School at Salem, Mass., have been offered instruction in the use of carpenters' tools. From fifty to sixty volunteered to learn the use of hammers, saws, planes, augers, etc. The amount of time given to this work was not large (one lesson of one hour each week), but much interest was shown in the work, and many articles, such as easels and bookcases, were made by the young ladies for their own use. Principal Hager says that the results are satisfactory.

The Legislature of New York passed an act in 1888 requiring the State normal and training schools "to include in their courses of instruction the principles underlying the manual or industrial arts, and also practical training in the same to such an extent as the Superintendent of Public Instruction may prescribe, and to such further extent as the local boards respectively of said normal and training schools may prescribe." (2—44, 45)

At this same time, the State Normal School at Millersville, Pennsylvania, had begun to teach woodwork "in one of its recitation rooms, which had been fitted up for the purpose." (2—45)

But none of these normal schools were training the kind of special teachers of manual training needed in schools of secondary grade. Such schools found their best source of supply for manual-training teachers to be the Worcester Polytechnic Institute (formerly Worcester County Free Institute of Industrial Science), Worcester, Massachusetts, and later the School of Mechanic Arts of the Massachusetts Institute of Technology, Boston, and the Manual Training School of Washington University, St. Louis. None of these gave professional courses for teachers, but they did give thorough and well-organized courses in the various types of shopwork and drawing that were beginning to be taught in high schools. In fact, the high schools had, in essential features, adopted the courses taught in these schools.

86. A Professional Course Developed at Teachers College. When the Industrial Education Association was organized in New York City in April, 1884, the first of the five stated objects was "to obtain and disseminate information upon industrial education, and to stimulate public opinion in its favor"; and the last of these was to provide instructors for

schools and classes and, if necessary, to train teachers for this work. (cf. 79) On moving into the building formerly occupied by the Union Theological Seminary, 9 University Place, in October, 1886, the work of the Association expanded rapidly. By March, 1887, instruction was being given in the Seminary building to 992 pupils. Of this number, 65 had been teachers. During the following winter, it became evident that, in order to accomplish its purpose, the Association must enter upon the work of training teachers, and so proceeded to organize normal classes. "This was no sooner done than it became evident that such a scheme must assume the proportions of a training college, needing the guidance of a trained and expert educator. A president must be found, and search was at once begun for the right man for the place." (4—II, 295) Nicholas Murray Butler, professor of philosophy and education at Columbia University, was elected president. Without giving up his position at Columbia, it was arranged that he give part of his time to this new college, to be known as the New York College for the Training of Teachers.

The first prospectus of the College stated that "for the present at least the instruction given will be almost wholly confined to those hitherto neglected factors in education which may be included under the name of industrial training." (4—II, 296) Both men and women were admitted. Applicants were required to be at least eighteen years of age and to pass examination in arithmetic, plane geometry, English, history, and composition. The regular course of study for men consisted of (a) history and science of education, 2 hours a week; (b) mechanical drawing and woodworking, 4 hours a week; and (c) modeling and industrial art, 3 hours a week. To these were added teaching under supervision in the model school and attendance upon certain lectures. (4—II, 297) Charles R. Richards (1865–1936) was professor of mechanical drawing and woodworking, a position that he held until the opening of Pratt Institute in 1888.

In 1891, important changes took place at the New York College for the Training of Teachers: Dr. Butler's full time was required at Columbia University, and Walter L. Hervey,

dean of the faculty, was made president. Elizabeth A. Herrick was elected professor of form study and drawing and Charles A. Bennett, professor of mechanic arts. In 1892, a special course in woodworking and mechanical drawing for prospective teachers and supervisors of manual training was given. It consisted of drawing and thin woodwork for the fifth and sixth grades, which could be taught in the regular schoolroom, and a course in joinery and elementary wood carving recommended for the seventh and eighth grades. The distinctive fact about this special course was that it was pursued from the standpoint of method of teaching. Once a week, also, a "department conference" brought together the instructors and the students majoring in manual training to discuss questions of equipment, organization of subject matter, and other teaching problems.

Announcements for the year 1893-94 brought a change in the name of the college, from New York College for the Training of Teachers to Teachers College. At this time also, the manual-training faculty was strengthened by John H. Mason, who came from Wisconsin to be associate professor, and by several instructors. The number of courses in mechanic arts was increased from seven to fifteen, the especially significant additions being three professional courses announced as follow:

History and Principles of Manual Training

1 period each week, Wed., 1.00 to 2.00

Origin and development of the manual-training idea; some characteristics of manual training in Sweden, Germany, France, England, and America; educational principles underlying manual training; a study of equipments and courses of instruction for elementary and secondary schools; the manual-training high school, its distinguishing characteristics and its place in the American system of education.

Economics of the Planning, Equipping, Organization, and Management of Manual-Training Schools. (To be given for the first time in 1894-95.)

Planning, with reference to site, location, points of compass, rooms required, size of each and location with reference to use, light, ventilation, economy of heating, accessibility and convenience; tools and appliances required for a given range of work; when and how to purchase tools and machinery, arrangement of the same with reference to their use, convenience, and safety of operation; selection of motive power, location of line shafts, kinds of hangers, belting, and other material required; fixing of responsibility,

arrangement of recitation and work periods, duties of engineer, janitor, and teachers; management, with reference to efficiency and economy in the instruction of classes and in the use of material in the workshops.

Observation and Practice Teaching

From 2 to 6 periods each week

A course affording opportunity for students to observe and to teach, under the eye of a critic teacher, grammar and high-school classes from the Horace Mann School in the various lines of work taught in the department.

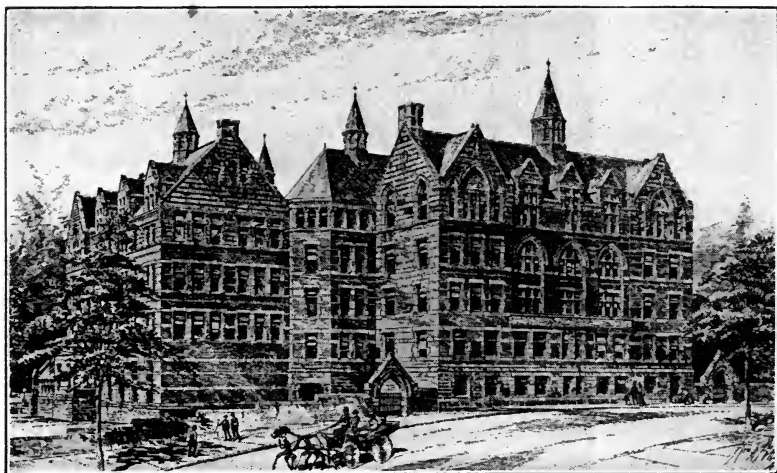

FIG. 133. MACY MANUAL ARTS BUILDING, TEACHERS COLLEGE,
NEW YORK CITY

This course is given only in the senior year. Each student must observe and teach in at least two subjects during the year, and no student will be recommended for a diploma whose work in this course is unsatisfactory. (5—17)

A two-year, major course in manual training leading to the college diploma was announced; also a group of courses for students desiring to take work in manual training as one of the requirements for a degree. (5—18, 19)

In the two-year, diploma course, the required work, in addition to the nine courses in the mechanic arts department, were three courses in psychology and history of education, one in the science and art of teaching, and four in form, drawing, and color. This diploma course, therefore, set a new standard for special teachers of manual training.

The practical carrying on of this course was made possible

by the moving of the College to 120th Street and especially by the gift of the Macy Manual Arts Building. Fig. 133. In the basement of this building was a blacksmith shop, a foundry, an engine room, and a stockroom and repair shop. On the first floor was a machine shop, wood-turning and pattern shop, lecture room, library, and offices. Fig. 134. On the second floor was a large shop for benchwork in wood, another for modeling and wood carving, a room equipped with ordinary school desks for elementary manual training, and a room for high-school mechanical drawing. A larger room for college classes in mechanical drawing and others for clay modeling, also a lecture room, were on the third floor. The fourth floor was taken up entirely by studios for drawing and painting, a lecture room, and offices of the department of art education.

By the terms of the agreement between Teachers College and Columbia College, which became effective July 1, 1893, the degree-giving power of Teachers College was transferred to Columbia; courses leading to degrees were in charge of the faculty of philosophy of Columbia; and certain members of the faculty of Teachers College were on the faculty of philosophy of Columbia. Through this agreement, certain courses at Teachers College were accepted, not only for the A.B. degree but also for the A.M. and Ph.D. degrees. Included among these was a course in the pedagogy of manual training. In the Columbia catalogue of courses given in the School of Philosophy, 1896-97, it was announced as follows:

XIII—*Manual Training in Elementary and Secondary Schools*: History and principles; courses, equipments, and methods of teaching. Lectures, essays, reports, and private reading. Two hours weekly first half-year. If accompanied with practice, four to six hours weekly the entire year. Professor Bennett.

Tu. and F. at 2, Macy Manual Arts Building.

A few students working for the A.M. and Ph.D. degrees took this course, which was undoubtedly the first graduate course in the pedagogy of manual training given in an American university.

87. **The Sloyd Training School in Boston.** While this rapid evolution of Teachers College was taking place at New York

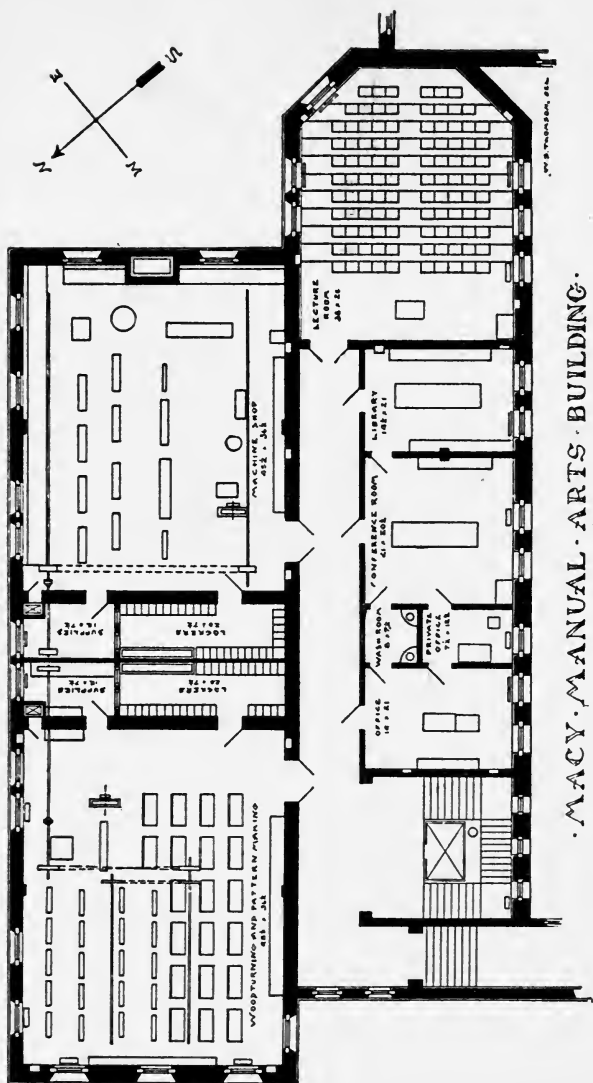

FIG. 134. FIRST-FLOOR PLAN, MACY MANUAL ARTS BUILDING

City, another center for the training of teachers was developing in Boston. Attention has already been called to the fact that, within a few months from the time of the arrival of Gustaf Larsson at Boston in 1888, he was giving instruction in sloyd to a class of public-school teachers. (cf. 82) In 1889, a notice was sent to kindergarteners and grammar-school teachers, offering free lessons in sloyd to teachers. One hundred and sixty teachers responded to the notice. Classes were formed to meet after school hours and on Saturdays. The interest of most of these was not permanent and, "as soon as the work began to look serious," the classes grew smaller. Busy teachers did not feel that they could spare the two hours a week to attend these classes. During the winter of 1890-91, however, applications for special teachers of sloyd began to come to the school, and it was announced that certificates of qualification to teach sloyd would be issued by the school to graduates approved by an examining committee. The requirements for the certificate were:

1. The satisfactory completion of twenty-five models (afterwards increased to thirty-one).
 2. Proof of ability to make and use working drawings, and of skill in the sharpening and care of tools.
 3. Evidence of teaching ability.
 4. A short essay on the theory and educational value of manual training—written in class. (6-8)
- The work now began to grow more serious and steady.

By the autumn of 1891, it became necessary to limit the number of students entering the school. First preference was given to graduates of normal schools or those with equivalent training and experience; and second preference to those who would give six hours weekly to the work. Seventy-eight women and sixteen men were accepted and a considerable number was refused admission. From this point on, the popularity and growth of the normal course at the Sloyd Training School continued.

From 1890 to 1895, the school was in the Rice School building; then for thirteen years in the building of the North Bennet Street Industrial School. Beginning in 1908, it was in

the building on Harcourt Street constructed especially for its use by Mrs. Quincy Shaw, who had been its patron from the first. In this building, the school expanded not only in number of students, but also and especially in the breadth of

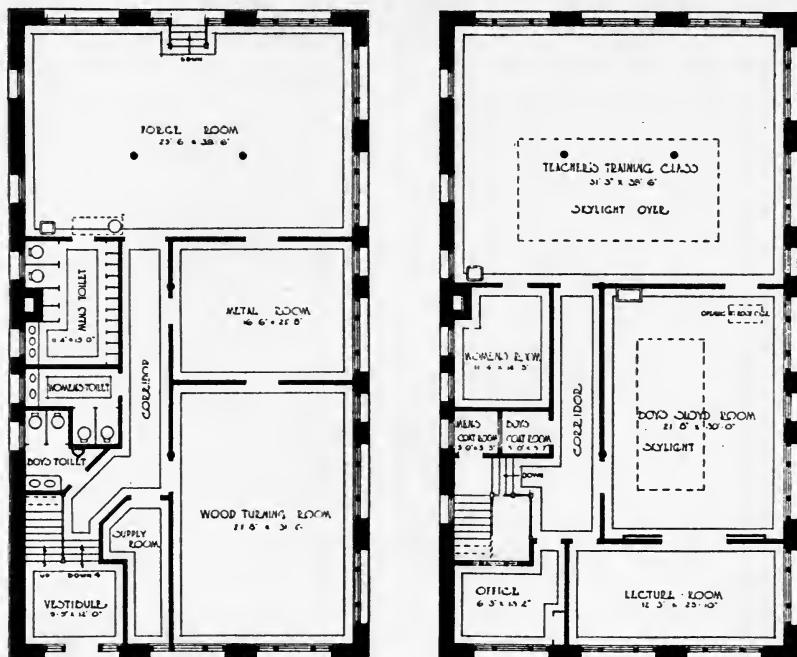

FIG. 135. FLOOR PLANS, SLOYD TRAINING SCHOOL, BOSTON

its training. Merely to consult the floor plans, Fig. 135, is to realize that the curriculum had come to include work in several handicrafts—forging, metalwork, wood turning, as well as elementary benchwork in wood. Bookbinding, patternmaking, and furniture construction by hand processes were also taught. These additional subjects made it possible to train men for secondary-school as well as for elementary-school positions. Moreover, whereas, at the beginning of the school, most of the students were women, now the student body came to consist very largely of men. Fig. 136.

The first class was graduated in 1892. At the end of twenty

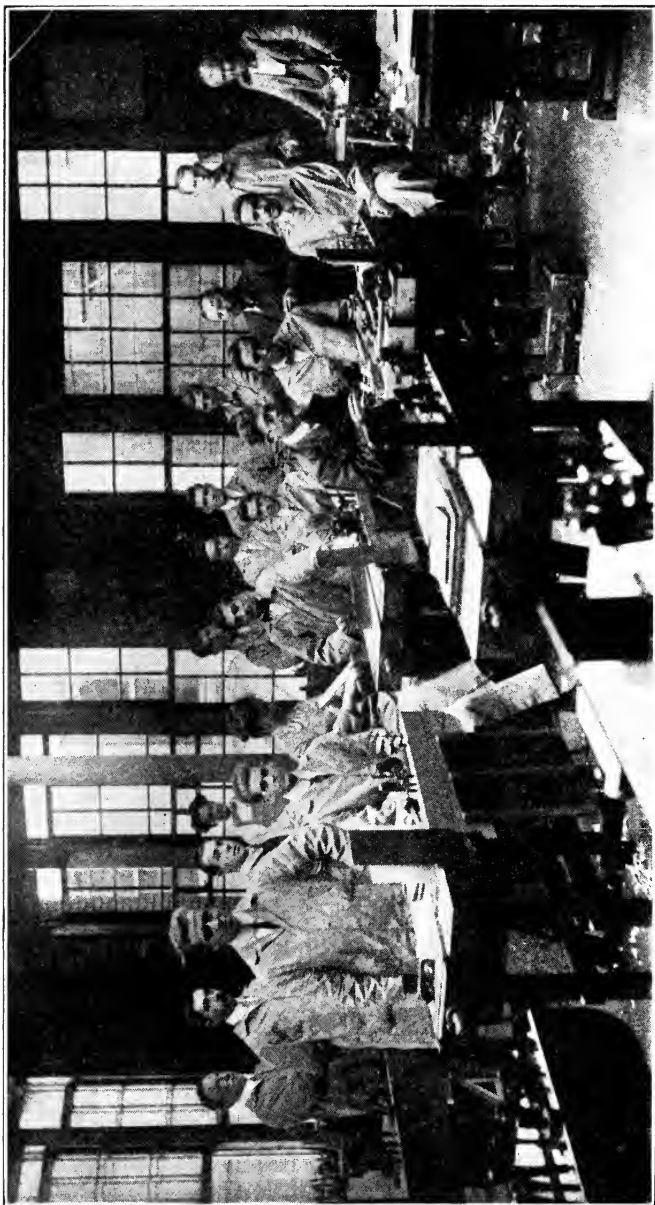

FIG. 136. CLASS OF 1913, SLOYD TRAINING SCHOOL, BOSTON

years, in 1912, the school had graduated 361 sloyd teachers. In the later years of the school, the Alumni Association, especially through its quarterly publication, *Sloyd Record*, was a very important factor in the development of the school. It should be stated clearly, however, that the notable success and



FIG. 137. PORTRAIT BUST OF GUSTAF LARSSON³

wide influence of this school were fundamentally due to the dynamic leadership of Gustaf Larsson, Fig. 137, who emphasized the belief that the essential qualifications in any teacher are "first, a proper understanding of and sympathy with the pupils; second, a professional training in the art and methods of teaching; third, a mastery of the subject matter." (7—XX, 176)

For the most part, his students were successful teachers

³Photograph contributed by Charles A. Kunou

before they entered his school. He placed teaching ability far above technical attainments, yet he sought to maintain a very high standard of technical performance.

88. Special Courses in State Normal Schools. During the period under consideration—up to the passage of the National Vocational Education Act in 1918—the preparation of special teachers of manual and industrial education was undertaken by many State normal schools. Only a few of the earlier or more typical ones, however, are considered here.

In the year 1893, new shops and new equipment were provided at the Oswego State Normal School, and a technically trained teacher, Richard K. Piez, was employed. Two elective courses in manual training were offered. "These courses could be substituted for certain courses in the regular two-year normal school curriculum."⁴ While these courses were merely the forerunners of the special courses offered later in the same school, several students graduating during this period have occupied responsible industrial teaching positions.

Beginning in 1902, when Joseph C. Park became the head of the manual-training department, a special drawing and manual-training certificate was available at the school. To secure it, one had to win the regular two-year normal school diploma and complete six courses (600 hours) in manual training and drawing. During the nine years while this plan was in operation, many holders of this certificate secured positions as special teachers of drawing and manual training.

In 1911, the State assumed control of industrial-arts-teacher education and a new two-year course went into effect at Oswego. This consisted of psychology, history and principles of education, English, methods in science, shop administration, drawing, shopwork, and practice teaching. The shopwork included joinery, cabinetmaking, wood turning and patternmaking, machine-shop practice, printing, molding, and forging. This course continued until after the passage of the Federal Vocational Education Act, when it was modified to meet new conditions.

⁴From data furnished by Dr. Joseph C. Park, September 27, 1935.

One of the early schools to undertake the training of special teachers of manual training was the State Normal School at Oshkosh, Wisconsin. Beginning in 1903, this school offered a special group of studies for certain students in their junior and senior years; thus producing in effect a two-year manual-training course. The outstanding feature of this course was that it was planned quite definitely for teachers and supervisors of manual training in all the grades of the elementary schools. What was called sloyd occupied three or four periods a week throughout the two years, or eight terms. Drawing was included for two terms, mechanical drawing for one, constructive work for one, theory of sloyd for one, and practice teaching for three terms. The remainder of the student program was filled with general educational and professional studies.⁵

The instruction in manual training at the Oshkosh Normal School was under the direction of L. L. Summers, a graduate of Iowa College, who had spent two and a half years in the special study of manual training, first at Pratt Institute and then in England, France, and Sweden. While Mr. Summers gave the name sloyd to his shopwork in wood, much of it was very different from the sloyd of Sweden. The most distinctive part of it was wood construction work for the small children in grades one to four. In the first two grades, much use was made of wood lath or other similar strips of thin wood which could be readily sawed to desired lengths and nailed together. Cart wheels were made of thin wood. In the third and fourth grades, a great variety of animal cages on wheels were made with these same kinds of materials; also bird houses, seed boxes, and miniature railway trains. In the fifth grade, models of various mechanical devices were made. This primary-school woodwork was thus correlated with other school subjects. (8—5—14)

In the year 1903, the legislature of Kansas passed an act establishing a State Normal School of Manual Training at Pittsburg. This school for the training of special teachers of

⁵Curriculum information received from letter written by H. H. Whitney, Feb. 11, 1935.

practical arts subjects was, at first, a branch of the State Normal School at Emporia and was controlled by the same board of regents. The first principal of the school was R. S. Russ, through whose efforts as superintendent of schools, manual training had been started in the public schools of Pittsburg in 1899. (9—10)

The school was open to (a) holders of first- or second-grade teachers' certificate, (b) graduates of high schools, and (c) those who passed an examination in arithmetic, reading, geography, grammar, United States history, physiology, writing, and spelling.

The course of instruction consisted of two years' work in three academic subjects and manual training or domestic science. The manual-training instruction, as illustrated in the first announcement of the school, consisted of such hand-work in various materials as was taught in the progressive schools of that time. It was organized according to the needs of the elementary-school grades in which it was to be taught. In the first four were paper weaving, folding, cutting and pasting; braiding and weaving raffia, corn husks, rushes, grasses, cord, and wool; sewing; clay modeling; and rough woodwork. In the fifth and sixth grades were thin woodwork, reed basketry, pottery, and cardboard work. In the seventh and eighth, cardboard work involving the use of cover paper, was taught, also the modeling of decorative forms in clay. The announcement for 1903 indicated that a woodworking equipment had been provided, including lathes for wood turning.

A. M. Bumann, from the St. Louis Manual Training School, was the teacher. Concerning the character of the woodwork, it was stated that "the exercises may take the form of a joint, showing some method of construction, or a series of practice forms to develop skill, or an article of use. (10—21)

No course was given in the special pedagogy of teaching manual training, but a ten weeks' general course in theory and practice of teaching was included in the work of the second year.

In 1905, the course was extended to three years. Me-

chanical drawing, patternmaking, and molding and forging were added to the announcement of courses. In 1908, a four-year, life-diploma course in manual training was announced, a similar course in art and manual training, and another in domestic art and domestic science. In 1910, a course in "methods" was announced for teachers and advanced normal pupils preparing to teach manual training. This included practice teaching, history and development of manual training, plans for equipping manual-training departments, costs, etc.

Then came the separation of the school from the one at Emporia, followed by an expansion of the curriculum and rapid general development under the presidency of Dr. W. A. Brandenburg. Since 1913, the industrial-education work of the school has been under the direction of A. H. Whitesitt, and courses on the college level have been developed.

89. Teacher Training in Privately Endowed Institutions. While the publicly supported State normal schools have contributed much toward the development of teacher-training in the manual arts, the chief contributions have come from certain privately endowed schools with superior equipments and facilities for technical instruction. A few of the leading institutions will be allowed to represent this group.

The Blake Manual-Training School. One of the members of that group of Bostonians who played such an important part in the advancement of industrial education during the eighties and nineties was Anna S. C. Blake, who moved to California and selected Santa Barbara for her home. She carried with her the same philanthropic desire to help young people that inspired Mrs. Shaw, Mrs. Hemmenway, and their co-workers in maintaining industrial classes in Boston. She believed in training girls to meet effectively the practical responsibilities of the home and the boys to be industrially intelligent and efficient. And she acted in accordance with her convictions.

From Mrs. Hemmenway's Normal School of Cookery, Miss Blake secured a teacher, Emeline E. Torrey, who taught cooking classes in Santa Barbara beginning in October, 1891. Girls from the public schools came once a week from 4:30 to

6:00 o'clock. Soon a class of boys was coming every Saturday morning. (11—2) Miss Blake realized that something besides an hour on Saturdays should be provided for the boys. Being aware of the growing interest in the Swedish sloyd work in Boston, she decided to start a sloyd class in Santa Barbara. But, instead of sending to Boston for a teacher, as she had done when starting the cooking class, she selected Ednah A. Rich, a teacher in an elementary school in Santa Barbara, and sent her to Boston to be trained in sloyd. Beginning in May 1892, Miss Rich received private instruction from Gustaf Larsson until he left for a summer visit to Sweden. In September, she entered the Sloyd Training School and remained until November, when she returned to Santa Barbara and began to teach sloyd.

From the beginning of Miss Blake's school, there was full cooperation on the part of the public schools of Santa Barbara. Miss Rich was allowed to take boys from the public schools.

In the fall of 1893, the school was in a new building. In the summer of 1895, Miss Rich took the course in wood sloyd in Herr Solomon's school at Nääs, Sweden, and the courses in cardboard work and metalwork under Dr. Goetze in Leipsic, Germany. In the fall, she returned to Boston and completed her course at the Sloyd Training School. In 1896, she was made principal of the Blake Manual Training School. In the year 1897, the School Board of Santa Barbara accepted the gift of the school from Miss Blake, who had supported it most liberally up to that time. The citizens of Santa Barbara voted a special tax to provide for the maintenance of the school.

Manual-training instruction for high-school students was begun as follows: Joinery in 1899, wood carving in 1903; metalwork, tooled leather, and jewelry making in 1906; bookbinding in 1908, pottery in 1909, printing in 1911; wood turning, patternmaking, forging, and sheet-metal work in 1911. (11—1)

In 1906, to help meet the demand for well-trained teachers of sloyd, the School Board of Santa Barbara offered a summer course at the Anna S. C. Blake Manual-Training School.

Instruction was given in benchwork in wood, theory and methods of teaching sloyd, and practice teaching in classes of boys. The standard of admission was high, the course being open only "to teachers of experience and to graduates of universities and normal schools." The school term lasted for six weeks. The work day was from 9:00 to 12:00 A. M. and from 1:30 to 3:00 P. M. (12—)

The summer school was such a success that it was repeated the next year. Meanwhile Mary H. Tracy, a graduate of the Sloyd Training School in Boston, member of the Arts and Crafts Society of Boston, graduate of a normal school, and teacher of experience in academic subjects, had become the assistant to Miss Rich. She helped, also, in the summer-school instruction. At the close of the summer session, three teachers, who were also normal-school graduates, asked for a year's course in sloyd. Miss Tracy worked out the details of a course which might be taken in one school year or in equivalent summer-school terms. Four students took the course in the year 1907-8.

Owing to the unusual privilege offered of specializing in one subject for a full year and to set a high standard in this new course for manual-arts teachers, applicants for admission were required to have completed at least two years of college or normal school work, including pedagogy and psychology, or to be teachers with testimonials of successful instruction given.

The course of instruction was announced as consisting of "benchwork in wood, mechanical drawing in its application to manual training, care and use of tools, and finish of woods. . . . Methods of presentation to children's classes and comparisons of various systems with regard to their value as educational factors; discussion of theories and their exemplification; history and development of the manual-training movement in the United States and other countries; history of common tools and special study of equipments; and the economic problems of administration." Practice teaching in grade classes was required. (11-3)

In 1909, by act of the California Legislature, the school

became the State Normal School of Manual Arts and Home Economics. Miss Rich was elected president and continued in that office until her marriage to Lewis Kennedy Morse in 1916. During that period, the same high standards for admission were maintained, except that, beginning in 1912, in order to increase the number of men students and thus supply a need in the State for more trained men to teach the manual arts, requirements for the admission of men were based on certain qualifications and general fitness rather than on academic degrees, normal school diplomas, or extended teaching experience.

Two features of the work of those years deserve special mention. The first is that, in addition to the usual shopwork instruction in elementary woodworking, joinery, pattern-making, wood turning, forging, machine shop, sheet metal, plumbing, concrete work, house framing, mechanical drawing, and printing, the school provided courses in such art crafts as wood carving, bookbinding, pottery, metalwork, jewelry, and weaving, also extensive courses in design. The second is that students received training in social service work. By making special studies of local problems, conclusions were reached and then embodied in a thesis. This was one of the required courses in education. (13—)

Meanwhile the school was provided with a unique building on one of the most beautiful sites imaginable, overlooking city, ocean, hills, and in view of distant mountains.

Upon the retirement of Miss Rich in 1916, Frank H. Ball became president. Mr. Ball had been a teacher at Rindge Manual Training School in Cambridge, Massachusetts; at the New York College for the Training of Teachers; the University Elementary School, Chicago, and had been supervisor of manual training in Cincinnati, Ohio, and Pittsburgh, Pennsylvania. He entered upon his new work with enthusiasm, but his health failed and he resigned in February 1918. He was followed in June 1918 by Clarence L. Phelps, a graduate of Leland Stanford Jr. University, with extended teaching experience in California normal schools. He reorganized the school, extended its curriculum,

assisted in securing larger financial support, and increased its influence so that it soon gained full collegiate status and became the chief center of teacher training in practical-arts subjects in the State of California.

Throop Polytechnic Institute at Pasadena, California, was founded by Amos G. Throop in 1891. It was established to furnish a liberal and practical education to students of both sexes and of all Christian religious denominations. A shop building was erected and equipped in 1892 and, in a few months, there were classes in benchwork in wood, carpentry, patternmaking, iron work, machine-shop practice, and mechanical drawing. In connection with the elementary-school department of the Institute, a sloyd school was soon organized under the direction of Charles A. Kunou, who was trained in Sweden and had been assistant to Gustaf Larsson in Boston. It was this sloyd work for elementary school boys and girls under Mr. Kunou that inspired the organization of a training class for teachers of sloyd. This was about 1894. The course was one year in length. The endeavor was to admit those who were already teachers; but, in the beginning, these entrance requirements were more or less flexible.

In September 1896, Arthur H. Chamberlain, a graduate of the Cook County Normal School and of the normal department at Throop, took the place of Mr. Kunou, who went to Los Angeles to develop sloyd instruction in the public schools. In the summer of 1899, Mr. Chamberlain studied sloyd in both Germany and Sweden. That same year, through his influence, the normal course was expanded to two years and was made to include art as well as manual training and home economics. The standard of admission was raised to the requirement of a teacher's certificate, or college graduation, or high-school graduation plus some special ability. Classes from the elementary-school department were used for practice teaching in sloyd, and special groups from the academy department served for practice teaching in the high-school manual-training subjects. At this time, also, professional courses in the history and purpose

of manual training were given in addition to more general courses in psychology and the history of education.⁶

Under Professor Chamberlain's direction, the normal school of manual training, art, and home economics continued to be one of the outstanding features of the work at the Institute until the general change of policy and the development of a higher technical college, which came about in 1910.

Stout Institute. The history of Stout Institute is typically American. It begins with a successful industrialist, James H. Stout, of Menomonie, Wisconsin, who acquired money, not for the sake of the money but for the good he could do with it. He became interested in industrial education; and, in 1891, provided a manual-training shop and a teacher for the public-school boys of Menomonie. That teacher was John H. Mason, graduate of the Worcester Polytechnic Institute, with several years of experience in industry. This new school work was so popular that, in 1893, Mr. Stout erected a building costing \$100,000 and equipped it for instruction in a much wider range of industrial subjects. This building burned in 1897 and a better one was erected in its place. (14—) By that time, industrial education was growing in popularity throughout the nation; more trained teachers were needed. Mr. Stout realized this.

In 1903, he secured the valuable services of Dr. Lorenzo D. Harvey (1848–1922), then State superintendent of public schools in Wisconsin, to take charge of what was essentially a new institution known as the Stout Training Schools. (14—) The director of the training school for manual-training teachers was John H. Mason, the first manual-training teacher in Menomonie, who had spent five years in New York City as associate professor of manual training at Teachers College, Columbia University, and then returned to Menomonie in 1899.

Two manual-training courses were offered: one for teachers in elementary schools, and the other for teachers of secondary schools. In both of these, besides the instruction in manual

⁶ Most of the facts concerning Throop Polytechnic Institute were obtained from a letter written by Professor Arthur H. Chamberlain, February 19, 1936.

work, there was "professional work" outlined as follows in the circular of information for 1904-1905: "(a) psychological and pedagogical principles in their application to the teaching of manual training; (b) organization and management of manual-training classes in public schools; (c) history and literature of manual training; (d) observation of teaching and practice teaching throughout the senior year."

With excellent equipments, manual instruction was given in (a) handwork for primary grades; (b) woodworking for intermediate and grammar grades; (c) joinery, wood turning, and patternmaking; (d) molding and foundry practice; (e) forging; (f) machine-shop practice; (g) freehand and mechanical drawing.

The growth of this new school was rapid. The number of students in courses for manual-training teachers increased from three in 1903 to seventy-three in 1910. (15-41) In 1908, its name was changed to The Stout Institute. In 1911, following the death of Mr. Stout, which occurred in 1910, Stout Institute became a State school, thus insuring its continued support and development. By act of legislature in 1917, besides its two-year courses, three-year and four-year courses were provided for, and the Institute was endowed with degree-granting power. The Act provided that the State Board for Vocational Education act as a Board of Trustees for Stout Institute.

When Mr. Mason retired in 1905, George F. Buxton, a graduate of Pratt Institute, Brooklyn, New York, and Teachers College, Columbia University, and with five years of experience in teaching manual training, was secured to take his place. Under his supervision, the manual-training department continued its rapid development in both the manual and the pedagogical instruction. Emphasis was placed on many varied "exploration courses" for grades seven to ten in public-school manual training. The "professional work" as announced in 1908 included the following: (a) psychology and pedagogy, (b) observation of teaching and practice teaching, (c) organization and management of manual-training classes in public schools, (d) history of

manual training, (e) junior literature of manual training, (f) senior literature of manual training, (g) courses of study in manual training, (h) manual-training theory, and (i) psychological and pedagogical aspects of manual training. (16—25 to 29)

Under the guidance of Dr. Harvey, the professional work became a distinguishing feature of the teacher-training program of Stout Institute. His constant aim was to have the professional purpose influence all instruction. His viewpoint was expressed thus:

The work which each school undertakes to do in its field is three-fold—academic, technical, and professional. The academic involves the mastery of the subject matter of the courses, as a matter of knowledge. The technical involves a mastery of the handwork regarded as valuable for training purposes, as a matter of skill. The professional involves a study of educational principles and processes, and practice in applying them in the organization and administration of work in its particular field of educational effort, and a study of the relation of its special work to other phases of the public-school curriculum.

While each of these three phases has a content of its own and receives special treatment, the professional phase permeates the entire work in the other two. It appears in the academic work when students are led to observe and consider their own mental processes; to determine the use to be made of the subject matter in their subsequent work as teachers, and how they are to use it most effectively. It appears in the technical work as it proceeds when they are led to observe the order of development; to determine whether the particular order followed is essential or not; to note the character and relation of mental and motor activities appropriate and necessary for the proper development of the pupils they are likely to teach.

From beginning to end, students are impressed with the idea that they must not only have accurate knowledge of the subjects they are to teach, and skill in the different phases of handwork, but that they must know how to teach others the things they are learning, and to train others to do well the things they are trained in doing. (15—6)

Bradley Polytechnic Institute was opened to students in the fall of 1897. It was founded by Mrs. Lydia Bradley, whose purpose was "to afford the youth of Peoria and surrounding counties the opportunity to secure a practical and serviceable education and particularly to teach them to work and to regard work as honorable." (17—85) The first president of the faculty was Dr. William R. Harper, president of The University of Chicago; the first director,

Edward O. Sisson; and the first head of the department of manual arts was Charles A. Bennett, who came from Teachers College, Columbia University. The Institute began with a School of Horology—a trade school—and a School of Arts and Sciences, which included a lower academy, a higher academy, and two years of college work. In the lower academy, woodwork and drawing were required subjects for all boys, and domestic economy for all girls. In the higher academy and college, three courses were offered: the scientific, the technical, and the literary. The technical provided a maximum of mathematics, shopwork, and drawing.

With such a background of higher academy and college instruction, a well-selected faculty, and superior buildings and equipments, it was inevitable that the Institute should attract young men and women who were preparing to teach. When it became evident that students already in the institution were planning to become teachers, the faculty decided to offer special groups of studies for teachers of manual arts and home economics. As a preliminary to such groups and as a tryout offering, a summer school of manual training was announced for 1904. Eight courses in manual work were given and one lecture and discussion course entitled "History and Organization of Manual Training." Fifty-five students attended. This was considered proof that teacher-training courses were needed. The announcement of courses for the year 1905-1906, therefore, included a one-year course for teachers. This was to be of second-year college grade. The requirements for admission were to be four years of academic work, including certain specified academic studies, freehand drawing, mechanical drawing and woodworking, and one year of approved college work or an equivalent in successful teaching experience.

The purpose of this group of studies was stated as follows:

This group is especially well suited to those who have already proved their ability to teach other subjects and are now desirous of fitting themselves to teach manual training. To those already engaged in teaching that subject, it offers new points of view and advanced study. Many students will find it advantageous to spend two years in this group instead of one.

In 1909, this group of studies was expanded and reorganized, making two-year courses: one for teachers of manual training and the other for teachers of art and manual training in elementary schools. The latter course was intended especially for women preparing to teach art and elementary handwork, including sewing, in elementary schools. Three professional courses were now given instead of one. They were history of manual training, teaching manual training, and organization of manual training.

An outstanding fact concerning these two-year groups of studies was that more than 25 per cent of the time was devoted to freehand drawing and courses in design, culminating in a course in constructive design.

In 1912, the offering to prospective teachers was again expanded: Educational psychology and history of education were added to the work of the freshman college year; a three-year group of studies was outlined for teachers of woodworking in secondary and vocational schools; and a similar group for teachers of metalworking. A three-year group was added for teachers of the art crafts and design in high schools.

In 1914, requirements were announced for a four-year course leading to the B.S. degree in manual training, which, in later years, has become the leading teacher-training group of studies.

90. Teacher Training in Universities. The increasing demand that all teachers in high schools should hold at least a Bachelor's degree and preferably a Master's degree has influenced universities to develop professional courses in the field of manual and industrial education. These courses have differed in many respects, depending upon the equipments available, upon the qualifications of the faculty, and perhaps especially upon the viewpoint and policies of the administrative officers. A few examples will serve to indicate attitudes and procedures up to 1918.

As previously stated (cf. 86), the first of the universities to offer professional teacher-training courses in manual training, leading to university degrees, was Columbia. With

its excellent facilities for instruction in this field at Teachers College, it was natural that Columbia should become the outstanding leader among the universities and so set a standard not only for teachers, but also for supervisors and other administrative officers in the field of manual training and, later, in industrial arts and vocational education. Following Professor Charles R. Richards, who became director of Cooper Union in 1908, the teacher-training work was continued by William Noyes, then by Professor Frederick G. Bonser, beginning in 1910, and in 1916, with the addition of Dr. David Snedden and Dr. Arthur D. Dean.

The teacher-training work in this field at the University of Chicago was quite different. It may well be considered as having passed through two separate periods of development: the first under the immediate guidance of Professor John Dewey, during the ten years ending in 1904, and the second activated by Professor Frank M. Leavitt, during the years from 1910 to 1918. During the first period, emphasis was placed on industrial and art activities in vital relationship to all school work, and especially in elementary education. In discussing *The University Elementary School*, the laboratory school of the Department of Philosophy and Education, Professor Dewey said:

A large part of the educational waste comes from the attempt to build a superstructure of knowledge without a solid foundation in the child's relation to his social environment. In the language of correlation, it is not science, or history, or geography that is the center, but the group of social activities growing out of the home relations. It is beginning with the motor rather than with the sensory side. . . . It is one of the great mistakes of education to make reading and writing constitute the bulk of the school work the first two years. The true way is to teach them incidentally as the outgrowth of the social activities at this time. (18—I, 418)

With this new philosophy put into practice, all teachers needed to be taught the arts and crafts, industries and occupations, that were serviceable in the home, school, and play environments of children. The teacher-training curriculum, therefore, was not organized to produce special teachers of manual-arts subjects. In training the teachers, however, special teachers were employed to teach construction in

wood and metals, textiles and paper; also drawing and modeling, and art and design applied in a great variety of materials. In all of these, the ideal was to emphasize natural correlations with science, history, geography, and literature.

With the changes taking place during the ten years previous to the passage of the Federal Vocational Education Act in 1917, came changes in the professional course for teachers. More and more emphasis was placed on vocational education and on vocational guidance. In 1910, Frank M. Leavitt left his supervisory work in Boston and came to the School of Education of the University of Chicago as associate professor of industrial education. During the next eight years of adjusting industrial education to new ideals and new demands, he contributed two books of timely value, *Examples of Industrial Education*, and, with the assistance of Miss Edith Brown, *Prevocational Education in the Public Schools*. During this period also, he gave the first course in vocational guidance to be given in a university.

In the fall of 1906, Fred C. Whitecomb, a graduate of Teachers College, Columbia University, became a member of the faculty of Miami University. He taught courses in handwork to students in the School of Education who were in training to become teachers in elementary schools. In addition to this, he gave instruction in drafting and shopwork as elective courses for any student in the university. The same year, he planned a two-year course to prepare students to teach industrial arts in public schools. In the fall of 1907, several students registered for this course and one student was graduated from it. In 1907, a similar course was offered in art education, and the next year, also under Professor Whitcomb's direction, similar courses were given in music education and home-economics education. In 1912, the four-year curriculum in industrial education was started; in 1915, one in home-economics education; and, in 1917, one in commercial education. Later a similar curriculum was added in physical education. Briefly stated, these are the beginnings of the Division of Practical Arts of the School of Education at Miami University.

From the beginning of this development, some instruction was given in history and organization of industrial education, but at first it was not under a separate heading. In 1915, Professor Whitcomb established a course in the organization and administration of industrial education and later a course in the history of industrial education separate from the course in organization and administration.⁷

From what has been said, it should be clear that the teacher-training work in industrial education at Columbia University grew out of the demands for teachers, dating from the beginning of the work of the Industrial Education Association and gradually taking the form of a group of studies in Teachers College, leading to a diploma or to a degree. At the University of Chicago, during the early period, industrial instruction was given to all candidates for teaching in elementary grades; during the later period, groups of studies for special teachers were developed and with them professional courses for teachers, supervisors, and administrative officers. Miami University evolved a group of studies for industrial teachers as one of several units in a comprehensive department of practical arts. It remained for the University of Wisconsin in 1910 to add to its College of Letters and Science a department of manual arts offering courses to general college students and a special four-year group of courses for special teachers. A feature of the Wisconsin plan was that it involved the cooperation of several departments: the College of Engineering, and the departments of education, home economics, and agriculture. This new department was organized and developed by Professor Fred D. Crawshaw, a graduate of the Worcester Polytechnic Institute, who had served as assistant dean of engineering at the University of Illinois and earlier as instructor in manual arts at Bradley Polytechnic Institute. As stated in 1917, it attracted the three following classes of students:

1. Those who desire special, intensive training to fit for positions as directors and supervisors of manual-arts work in the regular public schools and in industrial and trade schools.

⁷ From letter written by Fred C. Whitcomb, September 30, 1935.

2. Those who, in addition to the preparation to teach some or one of the regular academic subjects of the high school, seek to equip themselves to teach one or more of the special lines of manual-arts work.

3. Those who wish to broaden their educational horizon and enrich the traditional program of liberal study by electing some work in manual arts, usually on the side of drawing, design, and the crafts.

In order to complete the requirements for graduation in the four-year special group of studies for teaching the manual arts, a student must take at least 30 credits (maximum 40) out of 128.

The distribution of the work . . . is about as follows: technical manual arts (including allied subjects), 47 hours; science, 10 hours; cultural subjects, 28 hours; education courses, 9 hours; elective, 26 hours; total, 120 hours.

The strictly professional courses included in this curriculum are: organization and administration, 2 hours; vocational education and guidance, 2 hours; teaching and supervision of manual arts, 2 hours; supervised practice, 2 hours; problems in manual training (seminar), 1 hour. (19—84)

To encourage men with superior industrial experience, but limited academic preparation and no professional training, to enter the University for rounding out preparation for teaching, two industrial scholarships were offered to "carefully selected high-grade mechanics."⁸

91. **Professional Associations of Teachers.** If the development of professional spirit among teachers is indicated by the character of their organizations for cooperation and advancement, then the Industrial Art Teachers' Association organized in Boston, December 28, 1882, deserves recognition as setting a standard that was worth following. A previous organization, known as the Massachusetts Art Teachers' Association, was organized in 1874 under the inspiration and guidance of Walter Smith; but it proved to be essentially an undergraduate organization of the Massachusetts Normal Art School, and ceased to function after a few years. On the other hand, the Industrial Art Teachers' Association of 1882 continued to grow in strength and influence. It continued because it satisfied a real professional need. Briefly, its origin was as follows:

⁸ For a comparative study of groups of studies and statistics, consult Siepert, Albert F. *Courses of Study for the Preparation of Teachers of Manual Arts Bulletin*, 1918, No. 37. U. S. Bureau of Education.

A convention of the teachers of industrial drawing in Massachusetts was held in Boston on December 29, 1881. "This meeting was so successful that it was resolved to hold a similar one in 1882, which was done. At this meeting a permanent organization was effected." (4—I, 200) Its purpose was to stimulate the free discussion of vital professional subjects at a meeting to be held once a year. As seen from the present viewpoint, there were two important factors in the success of this organization: The first was the layout of the program. In the three-hour morning session, only two topics were discussed. Thirty minutes were allowed for "opening exercises"; then thirty minutes were given Miss Deristhe L. Hoyt, of the Massachusetts Normal Art School, to present the subject, "The Industrial Arts: Their Relation to the Fine Arts." Forty minutes for discussion followed; then a recess of ten minutes. The second topic of the morning was "Drawing in Public Schools." For its presentation, Charles M. Carter was allowed thirty minutes, which was followed by forty minutes of discussion. In a similar time division, two topics were presented in the afternoon session, closing with thirty minutes for reports of committees and the election of officers. Beginning at 7:30 was a "supper and social gathering." (Later Miss Hoyt's paper was published by the Association.)

The second important factor in the success of this association was that among its members were the outstanding leaders of that time in the teaching of industrial drawing in public schools: Henry Hitchings, director of the work in Boston, was elected president; Walter S. Perry, then of Worcester, later of Pratt Institute, was vice-president; Albert H. Munsell, of the Normal Art School, was secretary-treasurer. On the executive committee were Otto Fuchs, Miss D. L. Hoyt, E. C. Colby, Mrs. E. F. Bowler, and Eben Rose. (4—I, 201)

Thus began a successful professional organization of teachers in the field of industrial drawing.

A somewhat earlier but less stable organization was the industrial-education department of the National Education Association. This was started at the Minneapolis meeting

in 1875. Professor S. R. Thompson of Lincoln, Nebraska, presented a petition signed by twenty members of the Association for the organization of a department of industrial education. After some discussion, the petition was granted. At the first session of the new department held at Baltimore in 1876, Professor Thompson was elected president. In his address to the members, he stated that the department would have before it "three more or less distinct lines of effort: (1) general discussion, (2) collection of statistics, (3) a free conference over the practical work of the class of schools here represented." (20—1876 —)

Some idea of the scope of the department can be gained from the following topics discussed at this first meeting: "What can be done to secure a larger proportion of educated labor among our producing and manufacturing classes," presented by Professor W. C. Russell of Cornell University; "What are the legitimate duties of an agricultural profession?" by Professor E. M. Pendleton; "Drawing as an element of advanced industrial education" by Charles B. Stetson of Boston, author of *Technical Education: What Is It?* published in 1874. (20—). The next year, 1877, the topics discussed were "Relation of the common schools to industrial education" by Professor S. R. Thompson; "Systematic manual labor in industrial education" by President George T. Fairchild of the Kansas Agricultural College; "The Russian system of mechanical-art education," etc. by Dr. J. D. Runkle, president of the Massachusetts Institute of Technology; and "The relation of manual labor to technological training" by Charles O. Thompson, president of the Worcester County Free Institute of Industrial Science.

A few years later, under the influence of Dr. C. M. Woodward and others, the name of the department was changed to Industrial Education and Manual Training, and there was a separate department of Art Education. Still later, there was a department of manual training and a department of technical education.

In this record of changes in name, one recognizes a strong tendency to subdivide groups of teachers in order to better

serve special interests. Sometimes, however, the subdivisions have come on account of a clash of dominating personalities rather than any real need for specialization. Such a clash of personalities or of private interests has sometimes defeated efforts to combine groups. A striking example of building an organization that did not function for personal and selfish reasons was The Industrial and Kindergarten Educational Association organized in 1889. The following is an abbreviated account of what appears to have been a successful start for an influential association when it was greatly needed:

“In response to the call for a meeting of those in the West interested and engaged in industrial and art education, the lecture room of The Art Institute in Chicago was well filled on the morning of Thursday, December 27th. Eight states were represented in the audience. There were three meetings on Thursday and two on Friday. Each of the meetings was well attended. The papers were listened to with close attention and many participated in the discussions.” (21—vol. III, No. 5—5) A committee on organization reported that the object of the association should be the promotion of art, industrial, and kindergarten education and that the officers should be a president, a vice-president from each state, a secretary, a treasurer, and an executive committee, consisting of the president, the secretary, the treasurer, and five members, each of whom should be chairman of a departmental subcommittee. (21—vol. III, No. 5—8)

A complete set of officers was elected from the outstanding leaders in their respective fields of effort. The meeting adjourned and the association never held another convention.

To those who look back upon the Columbian Exposition of 1893 as one of the great significant events in America's industrial and educational history, it seems appropriate that two of the great organizations of teachers of art and industrial arts should have begun under the inspiring influence of that exposition.

At the last session of the manual-training section of the Educational Congress held in connection with this Exposition

in the month of July, 1893, George Robbins of Frankfort, Kentucky, announced that all teachers of manual training present were invited to remain after adjournment to consider the feasibility of forming an organization. This after-meeting of the Congress adopted the name Manual Training Teachers' Association of America. The following committee was appointed to draft a constitution: George Robbins of Frankfort, George S. Waite of Toledo, and Charles A. Bennett of New York City. This constitution was written and adopted by correspondence. The election of officers, also held by correspondence, resulted in the election of George B. Kilbon, of Springfield, Massachusetts, for president, George Robbins for vice-president, and Charles A. Bennett for secretary-treasurer. Soon after election, Mr. Bennett resigned and Mr. Robbins became secretary-treasurer, and George S. Waite, vice-president. (22—3) The first annual meeting was held at Drexel Institute in Philadelphia, July 17—19, 1894. John W. Seville of Baltimore was elected president and Charles B. Howe of Port Deposit, Maryland, secretary.

What grew directly out of this small beginning is suggested by the chart, Fig. 138. The following list of presidents and meeting places gives additional facts:

MANUAL TRAINING TEACHERS' ASSOCIATION OF AMERICA

<i>Year</i>	<i>President</i>	<i>Place of Meeting</i>
1894	George B. Kilbon	Philadelphia
1895	John W. Saville	Chicago

AMERICAN MANUAL TRAINING ASSOCIATION

1896	Thomas W. Mather	New York City
1897	Thomas W. Mather	New Haven
1898	Charles R. Richards	Washington
1899	Charles R. Richards	New York City

EASTERN MANUAL TRAINING ASSOCIATION

1900	R. Charles Bates	Cleveland
1901	William E. Roberts	Buffalo
1902	Daniel Upton	Allegheny
1903	George H. Bryant	Boston
1904	Louis Rouillion	Philadelphia
1905	Clifford B. Connelly	Newark
1906	William Noyes	New York City
1907	William Noyes	Cleveland
1908	John C. Brodhead	Washington
1909	Frank M. Leavitt	Pittsburgh

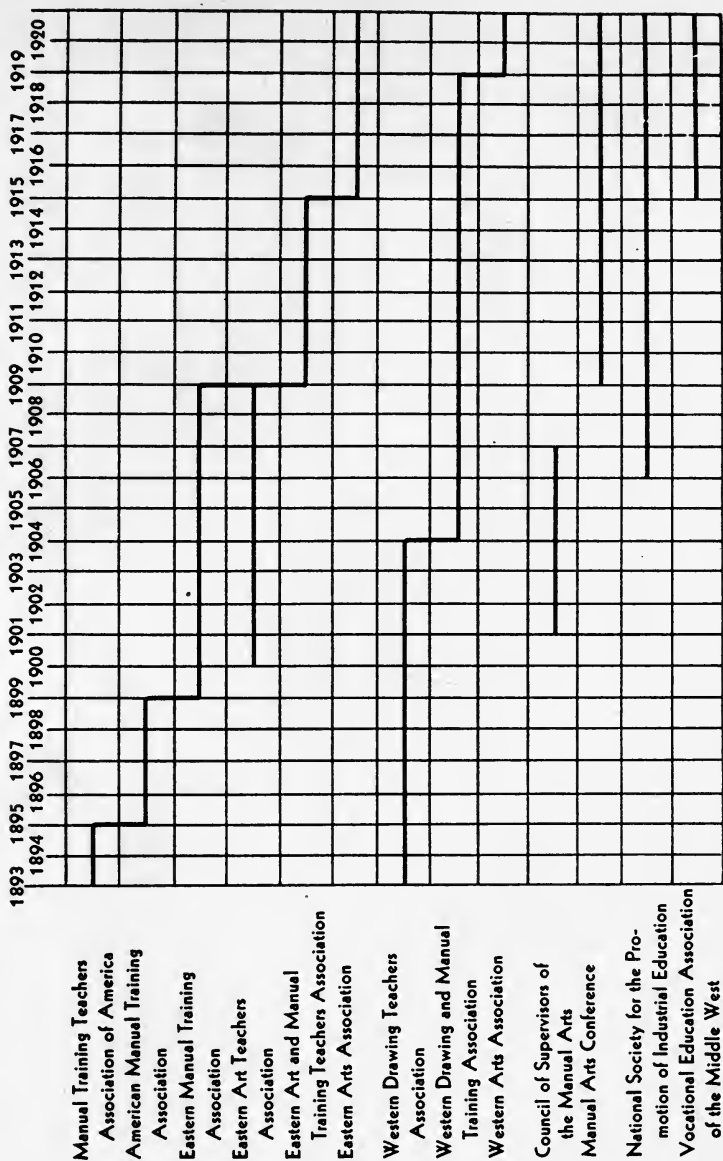

FIG. 138. CHART SHOWING DEVELOPMENT OF ASSOCIATIONS

EASTERN ART AND MANUAL TRAINING TEACHERS' ASSOCIATION

1910	Henry Turner Bailey	Boston
1911	Arthur D. Dean	Philadelphia
1912	C. Valentine Kirby	Baltimore
1913	Alvin E. Dodd	New York City
1914	Thomas D. Sensor	Atlantic City
1915	Harry L. Jacobs	Buffalo

EASTERN ARTS ASSOCIATION

1916	Millard B. King	Springfield
1917	Royal B. Farnum	Philadelphia
1918	E. E. McNary	New Haven
1919	Augustus F. Rose	New York City
1920	Frank E. Mathewson	Boston

(23—5)

From the above list, it will be evident that the original organization changed its name at its second annual meeting in order to add to its membership interested persons who were not teachers of manual training. Then, after four years more, since the meetings of the association had come to be held only in the eastern cities, and the programs, with few exceptions, were made up of eastern speakers, and since the membership was almost entirely of eastern teachers, the name was again changed to Eastern Manual Training Association. By this time manual training had made such progress that promoters outside of the profession were not necessary to maintain a successful organization. For ten years, under this new impulse, the association grew in strength and influence. Meanwhile, beginning in 1900, the art teachers of the eastern states had been building up an organization under such leaders as Solon P. Davis, who was its first president, Alfred V. Churchill, Fred H. Daniels, James Hall, Walter S. Perry, George H. Bartlett, and Arthur W. Dow. (23—5) In 1909, at Pittsburgh, Pennsylvania, the Eastern Art Teachers' Association and the Eastern Manual Training Teachers' Association held a joint convention and combined under the title, Eastern Art and Manual Training Teachers' Association. This result was brought about after several years of discussion and after a successful similar combination of art and manual-training teachers had taken place in the Middle West. The association continued under this long name until 1915. At

the Buffalo meeting that year, the name was changed to Eastern Arts Association.

The second organization to be started under the inspiration of the Columbian Exposition was the Western Drawing Teachers' Association. On the 10th of August, 1893, a group of teachers interested in art education met at the Chicago Manual Training School. This was brought about largely through the efforts of William S. Mack, formerly superintendent of public schools at Aurora, Illinois, but at that time the western manager of Prang Education Company, publishers and dealers in art supplies for schools. The group included many of the leading supervisors of drawing in the public schools of the Middle West.

L. L. Summers, then of Milwaukee and later instructor in manual training at the Oshkosh Normal School, was chosen chairman, and Antionette Miller of Chicago, secretary. A committee of three on organization was appointed, a constitution adopted, and the following officers elected: Ada M. Laughlin, St. Paul, president; Mrs. M. E. Riley, St. Louis, vice-president; Antoinette Miller, Chicago, secretary-treasurer. An executive committee of six was named, of which L. L. Summers was the chairman. The presidents and meeting places during the next quarter-century were as follow: (24—184)

WESTERN DRAWING TEACHERS' ASSOCIATION

<i>Year</i>	<i>President</i>	<i>Place of Meeting</i>
1894	Ada M. Laughlin	Milwaukee
1895	L. L. Summers	Aurora, Illinois
1896	Harriet G. Magee	Indianapolis
1897	Bonnie E. Snow	St. Louis
1898	Mrs. M. E. Riley	Detroit
1899	Myra Jones	Peoria
1900	Wilhelmina Seegmiller	Grand Rapids
1901	Clara A. Wilson	Rock Island
1902	Mrs. Jean McW. Mellor	Minneapolis
1903	John S. Ankeny, Jr.	Springfield, Ill.

WESTERN DRAWING AND MANUAL TRAINING ASSOCIATION

1904	M. Emma Roberts	Milwaukee
1905	Lucy S. Silke	Chicago
1906	Florence E. Ellis	Chicago

1907	Florence E. Ellis	Grand Rapids
1908	Charles A. Bennett	Indianapolis
1909	Carl N. Werntz	St. Louis
1910	Robert A. Kissack	Minneapolis
1911	Lillian S. Cushman	Springfield, Ill.
1912	Fred D. Crawshaw	Cincinnati
1913	Emma M. Church	Des Moines
1914	Robert W. Selvidge	Milwaukee
1915	Florence H. Fitch	Chicago
1916	S. J. Vaughn	Grand Rapids
1917	Edward J. Lake	Lincoln, Nebraska
1918	(No meeting held on account of World War)	

WESTERN ARTS ASSOCIATION

1919	Ira S. Griffith	Chicago
1920	Jeanette Buckley	Detroit (24—191)

For ten years the Western Drawing Teachers' Association continued to grow in strength and influence under the constitution originally adopted. Meanwhile the Manual Training Teachers' Association of America had ceased to be a national organization and had changed its name to Eastern Manual Training Teachers' Association. Fig. 138. This action left the manual-training teachers of the Middle West without the kind of professional organization they wanted. During the few years just preceding 1904, there was considerable discussion of the desirability of starting a new mid-western manual-training teachers' association. Those who opposed that plan preferred becoming a part of the Western Drawing Teachers' Association. The timely action of the drawing teachers was taken in 1903, when a committee, of which Bonnie E. Snow was chairman, recommended that "after the 1904 meeting, the Western Drawing Teachers' Association be known as the Western Drawing and Manual Training Association." This committee also recommended that the constitution of the Association be revised; that manual-training teachers receive recognition in appointments on committees for the 1904 meeting; and that a cordial invitation to cooperate be sent to the teachers of manual training in the western territory. (25—15) The adoption of these recommendations settled the question of forming a new

organization. There was no longer a demand for a separate association.

For thirteen years more, the Association continued to grow in influence; then came the World War and the omission of a convention in 1918. Before this date, however, new groups of teachers that did not call themselves either drawing or manual-training teachers had come into the association. These were represented on the programs by sectional meetings on household arts, printing, and vocational education. The feeling was developing that the name of the association was not broad enough. Even the drawing teachers much preferred to be called art teachers. Their work as well as their expanding ideals justified a change. Moreover, since 1900, the similar group in the East had been known as art teachers and, since 1915, the art and manual-training teachers had called their combined organization the Eastern Arts Association.

This wish to change the name was expressed in a proposed revision of the constitution presented in 1917 by a committee of which Lucy S. Silke was chairman. In 1919 the name, Western Arts Association, was adopted. Throughout the years from 1893, this Association has brought to its annual meetings the outstanding "speakers with a message" on the arts from all sections of the country, but especially from the East.

The average attendance during its first ten years when it was called Western Drawing Teachers' Association was 159; during the next fourteen, when known as the Western Drawing and Manual Training Association, it averaged 444. It began its career as The Western Arts Association with a membership of 655 in 1919 and 815 in 1920. (24—212) These figures, however, do not fairly represent the number of teachers in attendance because many local teachers came to meetings who did not join the Association.

In sharp contrast with the Eastern and Western Arts Associations were two other professional organizations whose aim was to limit their memberships to a few persons who were able and ready to do more intensive work. These

were The Council of Supervisors of Manual Arts in the East and The Manual Arts Conference of the Mississippi Valley in the Middle West. The Council of Supervisors was organized in May, 1901, under the leadership of Dr. James Parton Haney, supervisor of manual arts in the public schools of New York City. The work of the Council centered in the publishing of a yearbook. Its stated purpose was "the critical discussion of questions immediately concerned with the advancement of the manual arts of drawing, design, and construction work in public schools." Its membership was limited to forty active and one hundred associate members. In its seven years of activity, however, the membership had reached only 34 active members and 42 associates. The active members, in whom was vested all power and the privilege of contributing to the yearbook, were elected from the associate members.

All papers were published in the yearbook several weeks in advance of the annual meeting held in December, and the program of that meeting was made up of critical discussions of the papers in the yearbook, the leader in discussing each paper being designated beforehand. (26-5)

The presidents of the Council during the seven years were: 1901, James Parton Haney; 1902, Henry Turner Bailey; 1903, James Hall; 1904, James Parton Haney; 1905, Walter Sargent; 1906, Solon P. Davis; 1907, Frank Elliott Mathewson.

Dr. Haney once said: "The Council exists to do certain work. Its function is to produce each year its book, filled with contributions worthy the name professional. To achieve any measure of success, its work must be intimate and personal, its members must come into close communion, and submit to criticism, friendly but searching. A limit is thus placed upon size, while the aim remains quality in product. But while such product must perforce be the work of a few, as a serious and dignified contribution to the literature of the profession, it deserves well at the hands of the many." (7-VII, 101)

The Manual Arts Conference grew out of a letter written by Robert W. Selvidge to Charles A. Bennett of Bradley

Polytechnic Institute in 1908, expressing the opinion that there was great need of an opportunity for the teachers and organizers of manual training to get together in close conference where they might exchange views on questions of vital importance and express all of their heresies without being reported in educational papers. The next year, plans for such a conference took the following form:

1. The conference will consist of about ten or fifteen people, who will be sent formal invitations.
2. The conference will extend over three days, Thursday, Friday, and Saturday, November 11, 12, and 13.
3. Two sessions will be held each day and some social or semisocial event will be planned for each evening.
4. Each session will cover from two to three hours, and there will be a different chairman for each session.
5. The chairman of the session will select and present the topic for that session.
6. The discussion will be most informal but the chairman will endeavor to keep it sufficiently on the topic to reach definite results.
7. The subject for the last session will not be selected until the previous session, thus enabling it to summarize or work over any of the subjects discussed in the previous sessions. (27—10)

The invitation to the first meeting stated definitely that the conference was "not called to form a permanent organization but merely to help in the solution of problems of great importance."

The conference was held at Bradley Polytechnic Institute, Peoria, November 11—13, 1909.

The members of the conference were:

Louis A. Bacon, public schools, Indianapolis
 Charles H. Bailey, State Teachers College, Cedar Falls, Iowa
 William T. Bawden, Illinois State Normal University, Normal, Illinois
 Charles A. Bennett, Bradley Polytechnic Institute, Peoria
 Louis H. Burch, State Teachers College, Macomb, Illinois
 George F. Buxton, The Stout Institute, Menomonie, Wisconsin
 Fred D. Crawshaw, University of Illinois, Urbana
 M. L. Laubach, State Teachers College, Terre Haute
 Oscar L. McMurry, Chicago Normal College
 Walter Sargent, University of Chicago
 Robert W. Selvidge, University of Missouri, Columbia
 Leonard W. Wahlstrom, Francis W. Parker School, Chicago (27—13)

The first topic presented at the first session of this conference was "Our Unscientific Attitude" by Robert W. Selvidge. Only one topic was assigned to a session. The discussion was free and stimulating. The remaining four topics discussed during the conference were: "Controlling Ideas in the Selection of Problems in the Manual Arts—(a) for the Grades, (b) for the High School," Oscar L. McMurry; "Possibilities and Limitations of Industrial Work in the Grades," Fred D. Crawshaw; "Value of Different Factors in the Preparation of Teachers of the Manual Arts," William T. Bawden; "Is There Room in the Course of Study for the Art Crafts?" George F. Buxton. The conference closed with a summary of the topics discussed by Charles A. Bennett. (27—11)

This meeting was so satisfactory in plan and personnel that it was continued. The second meeting was held at Minneapolis in 1910, the third at Cincinnati in 1912, and the fourth at Peoria. For these first meetings, Mr. Bennett had acted as the chairman of a committee on arrangements. In 1914, an important change took place: Dr. Bawden, who had acted as secretary at the earliest meetings, had become the specialist in industrial education at the U. S. Bureau of Education in Washington, and he proposed that the Bureau be requested to take over the management of the Conference, it being understood that, if this were done, the Bureau would issue each year a summary of its proceedings as one of the Bureau publications. This suggestion was most acceptable to the members of the Conference, and Dr. Bawden, as the representative of the Bureau, became the director of the Conference. While this change added much to the effectiveness of the organization and broadened its influence, it did not change its fundamental plan of being limited to a small membership of leaders meeting for the free discussion of problems which had been previously studied by individuals or committees. The conference has continued to grow in interest and influence. Many of its members consider its annual meetings the most worth-while of the entire year.

Up to the present time two types of professional association have been mentioned: (a) the association that aims to attract

a large membership and thus extend its service and influence; and (b) the association that limits its membership to a selected few in order to do intensive work and thus render a professional service that cannot be done, or so readily done, by large groups of teachers. Both of these types, but especially the first, have been used effectively throughout the nation. State associations, city associations, and regional associations have continued to increase in numbers. Among the earliest of the city organizations to become well known was the Boston Manual Training Club organized in the fall of 1899. John C. Brodhead was its first president and Edward C. Emerson its first secretary. (7—I, 210) The School Crafts Club of New York City held its first meeting in May, 1902. Dr. James P. Haney was its first president and George F. Stahl was its secretary. (7—III, 235) Of the State associations independent of State teachers' associations, the Illinois Manual Arts Association was an early example, being organized in February, 1904. (7—V, 160) Another association of this same type was the Pacific Manual Training Teachers' Association, of which Arthur H. Chamberlain was president. (7—III, 106) Patterned after the National Education Association departments, many State and regional associations have provided section programs under various titles for the special benefit of teachers in the manual and industrial-education field.

SOURCE REFERENCES

1. *Report of the Commission Appointed to Investigate the Existing Systems of Manual Training and Industrial Education*, State of Massachusetts, 1893.
2. *Report of the Commission on Industrial Education* made to the Legislature of Pennsylvania, 1891.
3. *Report on the Preparation of Teachers and Manual Training*, New England Conference of Educational Workers, 1898.
4. Clarke, Isaac Edwards. *Art and Industry*. U. S. Bureau of Education, 1885-1889.
5. *Teachers College: Departments of Form, Drawing, and Color and of Mechanic Arts*, 1893-94.
6. *The Sloyd Experiment in Boston*. Sloyd Training School, 1893.
7. *Manual Training Magazine*. The Manual Arts Press, Peoria, Illinois.
8. *Announcement of Lake Winnebago Summer Manual Training School*, 1911.

9. Randolph, Vance. "The Teachers College at Pittsburg." *The Kansas Teacher*. Vol. XLI, No. 3, June 1935.
10. Manual Training School Bulletin, Vol. 1, No. 2, November 1903. State Normal School of Manual Training, Pittsburg, Kansas.
11. Rich, Ednah Anne (Mrs. Lewis Kennedy Morse). Unpublished Record of the Anna S. C. Blake Manual Training School.
12. Rich, Ednah Anna (Mrs. Lewis Kennedy Morse). Unpublished Account of the Santa Barbara State Normal School of Manual Arts and Home Economics, June 1932.
13. O'Reilly, Edmund. *A History of Santa Barbara State Teachers College*. Unpublished Master of Arts Thesis, Leland Stanford Junior University, 1928.
14. *The Story of Stout Institute*. A folder published by the Institute.
15. *Stout Institute Bulletin*, March 1911.
16. *Bulletin of the Stout Training Schools*, March, 1908.
17. *The First Decade, 1897-1907*. Bradley Polytechnic Institute, Peoria, Illinois.
18. *The University Record*, The University of Chicago Press, 1896.
19. Jarvis, Chester D. *Vocational Teachers for Secondary Schools. What the Land-Grant Colleges Are Doing to Prepare Them*. Bulletin, 1917, No. 38, U. S. Bureau of Education.
20. *Journal of Proceedings and Addresses*, National Educational Association, 1876.
21. *The Journal of Industrial Education*. Under the auspices of the Kitchen Garden Association of Chicago, beginning October, 1886, and continuing under various managements for about six years.
22. *Report of Manual Training Teachers' Association of America*, 1894.
23. *Program of Eastern Arts Association*, 1928.
24. Vogel, William H. "History of the Western Arts Association." *Western Arts Association Bulletin*, October, 1926.
25. Tenth Annual Report of the Western Drawing Teachers' Association, 1903.
26. *Year-Book; Council of Supervisors of the Manual Arts*, 1901.
27. *Report of Twentieth Manual Arts Conference*, 1929.

CHAPTER XIII

THE VOCATIONAL EDUCATION MOVEMENT

92. **Before 1906.** The Vocational Education Movement in the United States began in 1906 with the report of the Douglas Commission to the Massachusetts Legislature and the organization of the National Society for the Promotion of Industrial Education, but for thirty years previous to that time interest in practical education had been increasing. The manual-training movement had spread rapidly, causing instruction in the mechanic arts, especially in woodworking, to be given in city high schools and in many schools of upper elementary grade. Such instruction had been advocated by educators for general educational purposes, yet it was quite generally accepted by the public for its practical or industrial value. When well taught, manual training provided a foundation of industrial knowledge and habits of performance with tools that served as a basis for further instruction in a mechanical trade. Meanwhile, a few trade schools and technical schools of secondary grade had demonstrated what could be done in the training of skilled workmen. Some of these had started at the same point in their development as the manual-training schools; namely, with the analysis of tool processes and the teaching of resulting elements through exercises, after the manner of the Russian system of tool instruction. Others had continued to follow a modified apprenticeship method of instruction. The best of them combined these two and added much related mathematical, science, and technical information that was handed down to them from the schools of engineering and from the industries.

One of the schools of this period that was much visited and studied was the New York Trade School, opened in 1881. This was established in New York City by Colonel Richard T. Auchtmuty, who had studied the problem of trade teaching and reached some definite conclusions which he proceeded to

put into practice. (1—80) Not only were the students taught the best practical procedure in each trade, but also the scientific principles upon which these procedures were based. Students were enabled to learn both of these “thoroughly, expeditiously, and economically, leaving speed of execution and experience to be acquired at real work after leaving the school.” To accomplish all this, “carefully prepared lectures, manuals, diagrams, and experiments” were employed and instruction was given by skilled and experienced men in each trade. (2—5) The trades taught in this school in 1897 were house, sign and fresco painting, bricklaying, plastering, stone cutting, electrical work, steam and hot-water fitting, blacksmithing, carpentry, printing, sheet-metal cornice work, and plumbing. (2—13 to 40)

Intensive work was done by students in each of these trades. The usual length of a day course leading to a certificate was from October to April. The school grew rapidly in attendance—from 30 the first season to 589 the tenth. Men of wealth and influence served on its board of trustees, and it received the cooperation of trade committees from the Master Plumbers' Association, Master Painters' and Decorators' Association, the General Society of Mechanics and Tradesmen of New York, and other similar bodies. This type of school was adopted by the trade-school department of Pratt Institute established in Brooklyn, New York, in 1887.

In sharp contrast with these schools was the Williamson Free School of Mechanical Trades located about sixteen miles out of Philadelphia. This school, liberally endowed by Isaiah V. Williamson, was opened by 1891 and was designed to take the place of the old system of apprenticeship in so far as any school could do that. All boys admitted were bound as indentured apprentices to the trustees of the school for three years. On admission, a boy must not be under 16 or over 18 years of age and must give evidence of moral character and pass an examination in the common-school branches. For the first six months, he was given “a preparatory course in wood-working and mechanical drawing in connection with his studies in the schoolroom.” At the end of that time, he was

placed at one of the following trades, "the selection of which is made by the trustees, due regard being given to the inclination and adaptability of the boys to the trade to which they are assigned": (a) "woodworking in its various branches, such as carpentering, patternmaking, cabinetmaking, etc.; (b) building, including bricklaying, tile, range, and boiler setting, etc., plastering and stone masonry; (c) machine trade in all its usual details, including practical training in steam and electrical engineering, steam fitting, etc. Each boy takes but one of the trades named, and his instruction in mechanical drawing, which continues during his entire course, tends in the general direction of his trade." (1—86)

A third type of school to be established during that period was the Hebrew Technical Institute of New York. In the year 1883, thousands of Jewish immigrants reached New York on account of tremendous hardships imposed upon them in Russia. In the autumn of that year, a few citizens of New York met "to consider what might be done for these immigrants, and it was decided to start a technical school for their sons."¹

As stated in the first resolution passed by these citizens, the purpose of the school was to promote "industrial pursuits among Israelites." (3—7) In 1889, the director of the school, Dr. Henry M. Leipziger, said that the object of the school was both educational and economic: "educational, as it proposed to apply the best methods of teaching the principles that underlie the trades; economic, as it proposed to equip its graduates for some special calling in life." (4—21) Yet he wished to make it clear that the school was "not a trade school, but a technical school" because it endeavored "to make *young men* as well as *young artisans*." "It works on educational lines to economic ends." (4—25)

The course of instruction covered three years, one third of the time being given to academic studies. In its superficial aspects, it was essentially a manual-training school with a strong industrial bias, which sent its graduates into a variety

¹From a letter written by Dr. Edgar S. Barney, principal of Hebrew Technical Institute, dated April 30, 1928.

of industrial occupations. Several years later, under the directorship of Dr. Edgar S. Barney, it developed specialized senior-year courses in mechanical drawing, metalworking and toolmaking, instrument making, practical electricity, free-hand drawing and designing, automotive engineering, and automotive electricity.

Another school emphasizing instruction in academic subjects taught in their practical relation to industrial subjects was the California School of Mechanical Arts established at San Francisco through the gift of James Lick. Beginning in 1895, under the principalship of George A. Merrill, this school provided a two-year manual-training course followed by a two-year trade or technical course in any one of ten industrial occupations. (5—17, 18) Later, there came to the adjoining property, and under the principalship of Mr. Merrill, the Wilmerding School of Industrial Arts, thus, expanding the work of this center of industrial education. The Lick school then emphasized instruction for the machine trades and the Wilmerding for the building trades.

During this period also, evening schools for industrial workers increased. The mechanics institutes² were supplemented by such schools as Pratt Institute in Brooklyn and Drexel Institute in Philadelphia and a few apprentice schools conducted by corporations and by public evening schools. Among the earliest of the apprentice schools was the school established in 1872 by R. Hoe and Company of New York City, manufacturers of printing presses, machinery, and saws. Each class was given instruction two evenings a week, beginning at 6:30 o'clock. Supper was served to the class by the Company at 5:30. The instruction included mechanical drawing, arithmetic, algebra, and geometry. (6—101) For a short time, beginning in 1885, the Baltimore and Ohio Railroad Company maintained a technical school for the apprentices in the company's service. (7—III, 221) In 1902, the Grand Trunk Railway opened a school at Battle Creek, Michigan. In 1905, a note of warning was sounded

²Bennett, *History of Manual and Industrial Education up to 1870*, Chap. IX.

in a paper before the Railway Mechanics' Association, and a plan outlined for apprentice instruction to solve the problem of increasing the efficiency of shop workmen. This proved to be the initial motive force behind an extensive system of instruction in railway schools for apprentices that came into being a few years later. (8—147)

During the years preceding the Vocational Education Movement, it was generally assumed, and usually without question, that the teaching of trades should not be done at public expense; yet, in the later years of that period, there was a growing minority of citizens who were questioning the validity of the old attitude toward such expenditures. Among these were manufacturers and industrial workers in Springfield, Massachusetts. Moreover, the superintendent of public schools in that city, Dr. Thomas M. Balliet, and the principal of the new Mechanic Arts High School, Charles F. Warner, were in favor of starting an evening school of trades. Why not? The necessary equipment was in the Mechanic Arts High School building and unused in the evening; young men of the city needed and wanted the instruction; teachers were available; the School Board approved and the school was announced. The prospectus of the school contained the following statement:

The object of the Evening School of Trades is mainly to give men already employed in the trades, who know, therefore, at least a part of the trade in which they are employed, an opportunity to broaden their mechanical training and make themselves more efficient workmen. It is not the function of this school to train apprentices as such, but to supplement the imperfect and highly specialized training of modern shops by giving machine hands, helpers, and apprentices, so far as there are any apprentices, an opportunity to gain practice in a greater variety of work than would ever be open to any one man under the modern system of machine production. The aim of the school is to enable a mechanic to acquire a wider range of practical knowledge and to improve the quality of his work, and thus reach a higher classification in his trade with increased wages. This is a great advantage to the individual workman; but it does not materially affect the condition of the labor market in general. (9—234)

This school started with 61 pupils in two trades, toolmaking and plumbing. By 1904, there were 328 pupils in five trades. (9—236) Its unqualified success brought willing financial

support from the public treasury and attracted the attention of industrial leaders and school officials not only in Massachusetts, but wherever the basic facts about it were known.

During this period, Milton P. Higgins, who had been the superintendent of the Washburn Shops of the Worcester Polytechnic Institute from their beginning, discussed "Education of Machinists, Foremen, and Mechanical Engineers" at the 1899 meeting of the American Society of Mechanical Engineers. In his paper, Mr. Higgins pointed out that for twenty-five years the demands upon the machinist had constantly increased. He must now understand drawings, must quickly and with certainty make exact measurement and computations; he must deal with tempered steel and grinding substances; he is confronted with many refinements and complications not known to most machinists in the earlier days. The common schools, he said, were not giving the young machinist the required training, and the higher engineering schools were beyond his reach.

To provide the needed instruction, Mr. Higgins proposed what he called the "half-time school." The essential features of such a school he described as follows:

First. A school which shall include a first-class commercially successful and productive machine shop which is a department coordinate in importance, influence, and educational value with the academic department.

Second. A school in which the pupils are to have instruction and practice in this shop during half the working hours in five days of each week for a period of four years.

Third. Instruction in the public schools during a portion of the other half of the time, equivalent to a high-school course, restricted, abridged, and improved to meet the needs of these pupils.

Fourth. Special care and method of selection of pupils who finish the grammar-school course and who have special aptness for mechanical work.

Fifth. Management under a corporation whose trustees shall be practical business men. (10— —)

Mr. Higgins then discussed in considerable detail what the shop should be and why. A significant feature of the plan was that the school should aim to fit each boy by successive grades so that at any time he would be qualified to take up his work outside as a well-trained worker in the grade which he had completed and be prepared to enter the training of

the next higher grade. As he said, "the object of the school is to produce *many* well-trained and educated machinists and from these machinists *some* foremen, from the foremen a *few* superintendents, and finally an occasional engineer."

He believed that the ability and natural aptitude of the individual would determine which position he would occupy.

Pratt Institute later applied this principle.

93. The Report of the Massachusetts Commission. In 1905, Governor William L. Douglas of Massachusetts was empowered to appoint a commission to "investigate the needs for education in the different grades of skill and responsibility in the various industries of the Commonwealth." "They shall investigate how far the needs are met by existing institutions, and shall consider what new forms of educational effort may be advisable, and shall make such investigations as may be practicable through printed reports and the testimony of experts as to similar educational work done by other states, by the United States government, and by foreign governments." (11—1, 2) The Commission was appointed and Carroll D. Wright, formerly U. S. Commissioner of Labor, was selected to act as chairman.

An important feature of the work of the Commission was its public hearings held in the principal cities of the State. From these, the Commission gained several distinct impressions, which may be briefly summarized thus:

1. There was a wide-spread interest in special training for vocations. A practical personal interest was manifested by manufacturers and workmen, and a theoretical by "students of social phenomena" and of education.

2. There was a lack of skilled workman in the industries. This lack, however, was not chiefly a want of manual dexterity, though that was common, but of *industrial intelligence*, which was defined as "mental power to see beyond the task which occupies the hands for the moment to the operations which have preceded and to those which will follow it—power to take in the whole process, knowledge of materials, ideas of cost, ideas of organization, business sense, and a conscience which recognizes obligations."

3. The public schools were considered too exclusively literary in spirit, scope, and methods. They were not fully meeting the need of modern industrial and social conditions.

4. Excepting a letter from Charles F. Warner of Springfield, there was almost no remedial measures suggested.

5. Many of the labor unions showed suspicion and hostility because they

feared the Commission would formulate a plan for trade schools which would affect the labor market.

6. Technical schools could not solve the vocational-school problems.

7. There was a general feeling that the expense of the needed industrial education should be borne wholly or in part by the State. (11—3 to 7)

Concerning manual training as taught in the public schools of the State, the Commission said in their report:

The wide indifference to manual training as a school subject may be due to the narrow view which has prevailed among its chief advocates. It has been urged as a cultural subject mainly useful as a stimulus to other forms of intellectual effort—a sort of mustard relish, an appetizer—to be conducted without reference to any industrial end. It has been severed from real life as completely as have the other school activities. Thus it has come about that the overmastering influences of school traditions have brought into subjugation both drawing and the manual work. (11—14)

The most revealing part of the report was a study of the relation of children to the industries, conducted by Dr. Susan M. Kingsbury of Simmons College. On the basis of facts and figures gathered, it was estimated that 25,000 children between fourteen and sixteen years of age in the State were at work or idle. They were not in school, though only about one sixth of them had completed the work of the grammar grades. Neither were they learning a trade. These two years were therefore looked upon as “wasted years.” The reasons why they were out of school were usually their dissatisfaction with what they were able to get in the school and the ignorance of their parents who permitted them to enter the mill. If parents and children could have seen practical advantage in remaining in school till the age of sixteen had been reached, 66 per cent of them could have remained in school. Not more than one third of them were needed to work to help support the family. (11—44)

The Commission made two recommendations: The first was that the work of the elementary schools be so modified as to include “instruction and practice in the elements of productive industry, including agriculture and the mechanic and domestic arts, and that this instruction be of such a character as to secure from it the highest cultural as well as the highest industrial value; the second, that the work in

the high schools be modified so that the instruction in mathematics, the sciences, and drawing shall show the application and use of these subjects in industrial life, with especial reference to local industries, so that the students may see that these subjects are not designed primarily and solely for academic purposes, but that they may be utilized for the purposes of practical life." (11—20) Towns and cities were urged to provide new elective industrial courses in high schools, evening courses for persons employed in the trades, and part-time day classes for children from fourteen to eighteen who may be employed during the remainder of the day.

The second recommendation took the form of an Act to be presented to the Legislature for passing. This provided that the governor appoint another commission on industrial education to serve five years and to be assisted by a paid executive officer. This commission was to establish independent industrial schools and perform many other acts necessary to establish an industrial-school system for the State, independent of and parallel to the public-school system under the State Board of Education. (11—21)

This law was passed and approved by the governor in June, 1906. Dr. Paul H. Hanus, professor of education at Harvard University, was made chairman of the new Commission, and Charles H. Morse, superintendent of the Rindge Manual Training School in Cambridge, became the secretary and paid employe of the Commission.

This second commission then proceeded to carry out the provisions of the law, but was at once confronted with the indefiniteness and the seemingly conflicting elements in their problem. The general viewpoint of this Commission was expressed in their brief report in 1907. In 1908, a more extensive report was issued. In this, it was made clear that the Commission looked upon manual training as "an excellent educational exercise but has nothing or next to nothing to do with trade instruction." They were puzzled over the old question of whether trade instruction was a public-school matter. Is vocational training a public duty? Should trades be taught at public expense? Just how far in that direction

should they go? As the demand for vocational instruction had come largely from the manufacturers, it was decided to consult them and learn, if possible, just what they wanted. More than 900 manufacturers in twenty cities employing nearly 200,000 workmen, of whom about 25,000 were under eighteen years of age, were therefore visited and asked definite questions. From these interviews, it was evident that the manufacturers believed "that it is the duty of the State to furnish the same character of free, thorough elementary training for the productive industries that it is giving to the professions." (12—623) They agreed also that "the years from fourteen to sixteen can best be employed by acquiring general mechanical knowledge. The choice of a trade should not be made until that time. We do not care to employ young people under eighteen years of age." (12—623) They were uncertain about part-time school instruction, but were sure that evening schools were desirable. When they were asked to tell what kind of instruction would best serve their needs, they seemed to find it difficult to make definite statements. However, the Commission summarized what the manufacturers seemed to want as follows:

Any attempt to benefit our present employed must be started as an evening proposition. What we feel would be beneficial would be a somewhat exhaustive drill on the application of common-school arithmetic to mill problems, such as the calculation of the circumference of a roll from its diameter, the relative speeds of gears and pulleys, etc. The drawings which they make should be almost wholly freehand—machine parts, transmission layouts, etc., including the first principles of projection and the elements of design. The training in English should be confined to the reading of mill journals, the English of which is good enough, and the subject matter interesting and profitable. It might also lead to a voluntary reading of these technical papers, which would in itself furnish an education. The origin and transportation of our raw materials should be outlined; their preparation for the mill, the various processes to which they are subjected, the reasons for the use of different materials and different processes, the results as shown in the finished article, and the disposition of the goods, could all be made subjects of profitable instruction.

It is needless to say that all these subjects should be taught by men who are thoroughly familiar with the working conditions as they actually exist in the mills. In addition to this instruction, a museum of the materials in their various stages and samples of the finished goods should be conveniently displayed, in order to show definitely the effect of the different steps as out-

lined. You will notice that this does not call for a single machine, and yet we feel that the result on our operatives could not be other than beneficial.

Out of this evening work, when its good results are evident, would naturally grow part-time instruction for the employed and regular day instruction for young people intending to take up textile work. An expensive equipment is not necessary, and in all these schools we do not see the necessity for machinery other than hand-operated machines to illustrate the principles. (12—626)

After two years, in 1909, the work of this commission was merged with that of the State Board of Education; Dr. David Snedden was called from Columbia University to become State Commissioner of Education; for the next two years, Dr. Charles A. Prosser was State director of vocational education; and, in 1911, Charles R. Allen was made an agent for industrial education under the State Board of Education. These changes resulted in the rapid development of a comprehensive scheme of vocational education in connection with the public schools of Massachusetts which served as a model for study and inspired action by other states.

94. The National Society for the Promotion of Industrial Education. Following almost immediately after the publication of the report of the Douglas Commission in Massachusetts, timely action was taken looking to the formation of a national organization to extend and continue the discussion of industrial education. Through the influence of two men, Dr. James P. Haney, director of art and manual training in the public schools of New York City, and Charles R. Richards, professor of manual training at Teachers College, Columbia University, thirteen men met at the Engineer's Club in New York City on June 9, 1906. At this meeting, it was revealed that a deep and widespread interest in industrial education prevailed throughout the country. An organization committee of five was appointed that held frequent meetings in New York and Boston during the summer in preparation for the meeting which was held on November 16 at Cooper Union in New York City. About 250 persons, representing more than twenty states, were present. (13—No. 1, p. 13)

At this meeting a constitution was adopted and Henry S.

Pritchett, president of the Massachusetts Institute of Technology, was elected president; M. W. Alexander of the General Electric Company, vice-president; F. Everit Macy of New York City, treasurer; and Charles R. Richards, secretary. Fig. 139. Twenty-seven directors were elected, heading the list of which was Milton P. Higgins, who had acted as chairman of the organization committee. On this board of directors were not only manufacturers and educators, but also representatives of organized labor and social workers. Miss Jane Addams of Hull House, Chicago, was one of the latter. Among the hundreds who expressed approval of the organization were President Theodore Roosevelt, Dr. Felix Adler, Andrew Carnegie, Charles W. Eliot, Jacob Riis, and Dr. Elmer E. Brown, then U. S. Commissioner of Education.

Under the editorship of the secretary, there began at once the publication of a series of bulletins that carried the ideas of leaders in the movement to all parts of the country. The first of these contained the constitution and the addresses at the organization meeting. The second was a selected bibliography on industrial education. The third was an especially timely contribution entitled "A Symposium on Industrial Education." It was valuable at that time because it placed side by side the attitudes of manufacturers and labor leaders. The importance of understanding the viewpoint of each of these groups had already been evident, especially in Massachusetts where the appointment and the report of the Douglas Commission had aroused opposition in trade-union circles. The symposium consisted of answers to eleven questions sent out by the Society. These answers went a long way toward clarifying the issue between capital and labor so far as industrial education was concerned. Both groups were in favor of industrial education in general, but differed in details. Both considered trade schools a just charge on the public treasury.

The chief reason why trade unionists had opposed trade schools was because, as they believed, the advocates of such schools were usually men whose real motive was to create and maintain a surplus of cheap labor. They were, therefore,

especially opposed to trade schools run by or managed by corporations. They were in favor of trade schools run by or managed by themselves. Most of them were willing to have trade schools as a part of the public-school system. As



FIG. 139. CHARLES R. RICHARDS

Samuel Gompers said at a later date, they were willing to take their chances with the manufacturers when it came to voting on public-school matters. They would "favor public control of all trade schools, with representatives of labor on the board of directors."

Another reason why labor leaders had opposed trade schools was that manufacturers wanted schools open to any one who

could meet the aptitude and scholastic requirements for entrance, while they wished to limit entrance to persons already working at the trade or who had gained some practical experience in the trade. This, they said, was the only way to "prevent overcrowding of the industry" and the way to obtain the greatest benefits from the instruction. It was also the best way to prevent lowering the standard of the trade. (13—No. 3, pp. 12, 13) Both manufacturers and labor leaders generally favored *preparatory* trade-school work, including manual training, when well taught.

A comparison of the viewpoints expressed in the symposium makes it clear that the differences between the manufacturers and the labor leaders were centered in the one matter of control; both groups saw a real need for industrial education; both wanted it paid for out of public funds; but each wanted to manage it and say who should enter the schools and what kind of instruction should be given. One of the tasks of the National Society, therefore, was to harmonize these viewpoints enough to find some middle ground for united action. Such was the task accepted and vigorously pursued until both State and federal funds were available for vocational education.

But the capital-and-labor issue was not the only one. Quite as difficult in many respects and more deep-seated in tradition was the opposition of schoolmen. The Society therefore proceeded on a program of promoting industrial education by gathering facts concerning the need, best forms, and the administration of industrial education, formulating arguments, and publishing them. At first its efforts were centered on its bulletins and annual conventions; later, in forming branch organizations and on assisting in State and federal legislation.

The first of its annual conventions was held in Chicago in January, 1908, where a great deal of attention was given to apprenticeship. The second was at Atlanta, Georgia, where industrial education as a factor in national life was introduced and the importance of industrial education in public schools was set forth. At the third meeting in Milwaukee, a broader

program was presented, covering certain results of experience in trade-school work and discussing intermediate industrial schools. Bulletin No. 12 on "Legislation upon Industrial Education in the United States" was issued in November, 1910. Then came the Boston meeting, with an address by Dr. Georg Kerschensteiner, superintendent of schools in Munich, Bavaria, as the leading feature, and a notable program, dealing with four major topics: "Trade Education for Girls," "Apprenticeship and Corporation Schools," "Part-Time and Evening Schools," and "The Social Significance of Industrial Education." The report of this meeting took the form of four bulletins, one on each of the major topics of the convention. The Cincinnati meeting in 1911 again emphasized the value of part-time and cooperative industrial education; while the Philadelphia meeting in 1912 directed attention to the training of teachers for vocational education, but devoted its major effort to federal aid for vocational education. The leading speaker was U. S. Senator Carroll S. Page, who, a few months previous, had introduced a bill "to cooperate with the States in encouraging instruction in agriculture, the trades and industries, and home economics."

One of the important pieces of work undertaken by the Society was in connection with vocational-education surveys of cities. The findings and recommendations of each survey became the center of the program of a convention to be held in the city surveyed. The first of these was in Richmond, Virginia, in 1914; the second in Minneapolis in 1916.

The most outstanding work of the National Society, however, was done in helping to secure the passage of a law providing federal aid for vocational education. This is especially referred to in Section 99.

95. The New York State Report. Returning to the early days of the movement for vocational education, the most illuminating report following that of the Douglas Commission in Massachusetts was the one issued by the Bureau of Labor Statistics of the State Department of Labor in New York. This report, based on statistics gathered in 1907 and 1908, was prepared by Charles R. Richards, then director of Cooper

Union, New York City. "The object of the investigation was to determine the general relation of supply and demand in regard to skilled labor in the principal industries in the State, the conditions under which boys and girls enter the industries, and their chances for advancement, together with the opinions of both employers and employes as to the value and need of industrial training outside of commercial establishments." (14—1)

The industries studied represented the prominent skilled industries of the State, many mill and factory industries, employing low- and medium-skilled labor, and a few industries employing largely unskilled labor. Records were obtained from 1182 firms employing 317,932 persons in the following industries: Glass, metals, wood, leather and leather goods, printing and paper goods, textiles, clothing, cigars, confectionary, building. (14—2) Some of these were selected on account of the large number of minors—girls as well as boys—who were engaged in them.

This report was especially valuable at the time it was issued because it expanded the conception of the problem of industrial education in the minds of leaders in the movement. Stated in the words of the general summary of the report, "there is not a problem of industrial education but a hundred different problems, varying according to the nature of the different industries, according to local conditions as to wages and the size of establishments, and varying also according to the differing mental, physical, and will capacities of boys and girls entering the industries."

In the first place, it is evident that the intensity of the problem varies greatly among different industries. It is greatest in trades demanding a high degree of skill and intelligence and much less in the industries employing workers of low-grade skill upon specialized operations. Furthermore, the problem differs according as the industry is on a piecework or day-wage basis; it is affected by the age at which learners can be satisfactorily employed, and it assumes one aspect in those industries housed in a factory and another in the outdoor building trades. Another factor is the influence of immigration. The increment from this source has affected, and still continues to affect largely, the supply of skilled labor in certain trades while it leaves others almost untouched. From these many considerations, it becomes clear that no one method is competent to meet the situation in all its aspects, but that

many plans must be made use of to develop anything approaching comprehensive and adequate results. (14—7)

From the report's discussion of apprenticeship, the following paragraphs are quoted because they present a picture of apprenticeship under typical conditions in American industry at that time:

Various systems of training beginners exist in the different industries according to the nature of the work performed and the organization of the industry. The apprenticeship system is a survival from a period when only one class of industrialists existed, viz., the master-workman who was both merchant and craftsman and who in his own person bought and sold and practiced all the operations of the trade. The apprentice, who was in turn to become the master, was at once both assistant and learner, and he received a training which it was to the advantage of the master to make as thorough and complete as possible. Later on, the journeyman appeared; but, for a long period, he merely marked a state in the development of the master-workman and did not affect the status of the apprentice. When, however, the capitalist appeared and with him the fixed body of wage earners, the apprenticeship system lost its natural place in the industrial order. The master-merchant became the financial director and the master-craftsman became the shop director or the wage earner. The first of these is in no position to perform the function of teacher, and the others have no interest in so doing.

The modern organization of industry on the capitalist basis means the employment of numbers of workmen as wage earners whose sole responsibility is the forwarding of the productive tasks assigned to them. Such organization generally also means extended division of labor. It means these things whether hand power or machinery be used in the industry. In the trades where machinery is used, the value of the workman's time for purely productive purposes is increased by the added cost of machine and power. With the entire working force engaged upon production, it is to no one's interest to turn aside and instruct the learner, and such instruction, if in any sense comprehensive, can be given in the direct course of production only at a certain immediate loss.

Under these conditions, the employer of today, drawing his workmen from the general labor market, that in some cases is largely fed by immigration, no longer feels the same individual necessity and responsibility for the training of beginners, and hesitates to assume the cost and inconvenience of such a provision. The maintenance of a thorough apprenticeship system, having become exceptional, imposes in a sense a penalty upon the manufacturer who undertakes it inasmuch as he has no guarantee that apprentices will remain in his employ. Furthermore, the great subdivision of labor that characterizes all modern industries on a large scale imposes peculiar difficulties in the way of a thorough and comprehensive training, inasmuch as such a training involves a shifting of the apprentice from one branch to another that lessens his productive value. All these conditions make the employer slow to assume the trouble and expense of a thorough apprenticeship system. The tendency

is more and more to place the beginner upon certain special branches at the tools and let him develop as quickly as possible into a productive unit.

On the other hand, as pointed out above, the journeyman under ordinary conditions has no interest or advantage in the training of an apprentice. His first consideration is, of necessity, his own wages, and especially in those industries that are upon a piecework basis, the journeyman has no time for teaching; furthermore, he is apt to look upon the apprentice as a future rival who will add to the supply of skilled workers and reduce his own chance of employment.

Another difficulty, and a very large one, that faces the apprenticeship question is the unwillingness of the American boy to submit to a long period of training at low wages for the sake of future opportunities. The tendency of the American boy is toward a short cut; he resents the rules and restrictions of the apprenticeship period and turns to openings that yield larger immediate returns. That this attitude is justifiable and natural in many cases where the so-called apprentice is given practically no assistance toward attaining a really broad training and where he is left largely to chance and his own initiative to pick up anything more than the rudiments of a trade, must be conceded. This attitude is only removed when the apprentice feels that his interests are being cared for and a systematic effort is being made to open up a future worth working for. That it is removable is satisfactorily shown in those instances where provision is made for systematic training and technical instruction on the part of the employer.

Another cause that holds back a bright boy from the apprenticeship is the low wages paid. Whereas the journeyman's wage has been advanced in most of the skilled trades under the influence of organization, the wages of the apprentice have not advanced in proportion to the demand for young men in the industries. *Organized labor*, with its mind almost solely upon the *advancement of the standard of living*, and the *employer*, with his mind almost solely upon the *increase of profits*, have neither been concerned to advance the wage of the apprentice, and, with no influence to press them upward, these wages have remained extremely low.

Owing to these many conditions, apprenticeship in the sense of a broad and thorough training of the first-class workman has given place in many establishments and in many of the industries where it formerly prevailed to a so-called apprenticeship that trains in only a narrow range of work and fits only in some special line of skill. In such apprenticeship systems, the period of training is much shorter than in the older form and very often no age restrictions are imposed. Such systems figure to quite an extent in the industries studied in this report; notably in the machine woodworking trades, in the manufacture of gas and electric fixtures, in some branches of boot and shoe manufacture, in garment making and in the manufacture of cigars.

The helper system is another important channel through which beginners enter the skilled trades. The helper takes various forms in the various trades; but, in general, he supplies the relatively unskilled help needed to carry forward the work of the skilled journeyman. In some industries, as in certain of the building trades, he appears as an unskilled mature laborer that rarely advances to the grade of a skilled worker. In others, he is represented by a

younger class, below the journeyman, called juniors, improvers or helpers, who may be in regular succession to the skilled positions. In other cases, as in the machine shop, the helper is a "handy man" who performs odd jobs and in general the less skilled kinds of work such as finishing and filing. Such helpers have an opportunity to watch the operations of the journeyman and to become acquainted with his work, and where the conditions admit, the brighter and more progressive advance to the position of skilled workman.

One other general method under which skilled workers for the industries are recruited applies more or less to all industries in which great division of labor obtains. In such industries, beginners are generally put at first at the simpler operations, and, as they show ability and application, are advanced to somewhat more difficult processes or the manipulation of less simple machines. This advancement may continue up to that particular point in the organization beyond which the capacities or ambition of the worker are not sufficient to carry him. This system of developing skilled workers obtains in most women's trades, such as clothing, millinery and laundries, in the boot and shoe manufacture and in textile mills, and is found more or less combined with other systems of training in all other industries where much division of labor obtains. (14—24 to 27) . . .

Outside of the element of trade-union restrictions, the difficulty in the apprenticeship system may be summed up under two heads: one the unwillingness of the employer under the present conditions of manufacture to provide a really thorough apprenticeship training; and, the other, the unwillingness of the American boy to enter upon or to remain for a considerable period of years at low wages in apprenticeship that gives him no feeling of substantial progress and no promise of a broad training from which he will receive future benefit.

To sum up some of the elements of the situation in regard to the three main industries concerned, it may be said that in machine and engine construction a large number of firms show a willingness to take apprentices, and a tendency is appearing toward a modification of the terms of apprenticeship that shall make the system a matter of instruction rather than the mere employment of boys at restricted wages and that promises, in the case of large establishments, to make apprenticeship much more attractive for bright and ambitious boys. In the case of book and job and newspaper printing, the problem seems to be considerably complicated by trade-union restrictions. Outside of these restrictions, the conditions prevailing in the printing establishments allow of a competent apprenticeship training being obtained under commercial conditions; but there seems to be the same need as in machine industries for additional instruction in such branches as English and the technical and artistic details of the trade. In certain of the building trades, employers report willingness to take apprentices, but serious restrictions of apprentices by the labor union rules. In these trades, a general conviction apparently obtains on the part of the employer that some means of training beginners outside of commercial practice is needed. (14—36, 37)

The value of the New York report as a mirror, reflecting typical industrial conditions at the beginning of the movement for vocational education, was due, first, to the fact that it was

based upon carefully gathered statistics; secondly, it was due to the forward-looking questions asked; and thirdly to the illuminating discussion of the answers to some of these questions.

It should be recalled that the leaders in industrial education at that period in the movement were endeavoring to find the common ground between manufacturers and labor leaders in all matters pertaining to industrial education so that a program of State and federal aid might be promoted to a successful result. So many different and conflicting statements were made by individuals on both sides of the controversy that there was great need for a statistical basis as a guide in planning the details of proposed types of educational effort. To this end, the New York report made an outstanding contribution. For example, both groups were asked whether they would favor a general-industrial or trade-preparatory school for children from fourteen to sixteen years of age that would not teach a trade but would give better preparation for entering the industries than was being given in the common schools. The answers showed that 840 manufacturing establishments employing 219,734 persons favored such a school, while only 248 employing 58,976 opposed it. Of the trade unions, 1,500 favored it, 349 opposed it, and 574 did not answer. The vote therefore indicated that a working majority favored a preparatory trade school. In discussing the returns, the report concludes with these statements:

The question of the development of such schools is not only one of the foremost educational problems before the country today, but it is a question that is being increasingly recognized as having great practical bearing upon the whole problem of training for the industries. . . .

In any broad view of the subject it would appear that industrial education under public auspices should have at least two aims in view: one to assist the boy and girl to meet the immediate demand of the industries and so better enable them to obtain employment; the other to give them such breadth of training as will equip them for further development in their future careers. . . .

The hope of the industrial school of intermediate grade lies in the possibility of providing such a training for a large number of children that now leave school at 14 years of age, a training that will give them an advantage, whether it be to enter upon the work of the mill or factory or to take up the task of learning a skilled trade. The emphatic indorsement of this type of school by

both employers and organized labor should constitute a great encouragement to the educators who are endeavoring to develop such schools in different parts of the State. (14—43, 44)

On the other hand, while the questions concerning day trade schools for the older children—those from sixteen to eighteen years old—were framed in such a way as to bring favorable returns from both groups, the discussion of these figures was a recognition of the difficulties involved. In part, it was as follows:

The feeling of opposition to trade schools in general [on the part of the labor unions] is being replaced by an attitude which favors a trade school administered by public officials that will stand for thoroughness of training and for an after-period of practical experience in the trade before the journeyman's status is obtained. The opposition of organized labor toward the school which gives a brief and superficial training and sends out the graduate to compete with the journeymen is shared by most fair-minded employers and other students of the subject. On the other hand, all experience makes it clear that organized labor need have no fear of large increase in the supply of skilled labor through trade schools that limit the age of the student and which provide thorough and comprehensive courses of instruction.

One of the great difficulties under which the trade-school question labors at the present time is the undefined status of its graduates. No trade school can take the place of the old apprenticeship system. It can only, in the case of certain industries, supply a training that will advantageously take the place of the first one or two years of apprenticeship and prepare the learner to gain a larger benefit from further years of experience or apprenticeship before he reaches a status of skilled journeyman. Only when such status as to wages and period of further apprenticeship is agreed upon by the employer and the labor union will the trade school have a fair trial. Only then will it have a chance of successfully demonstrating its value and obtaining a recognized place in the industrial order. Whatever its development may be, it does not seem probable that the trade school will become the medium for training large numbers for the trades, but rather that its office will be restricted to training a superior workman and men of the foreman type.

It would seem clear that the trade school as a mere expedient to evade the restrictions of organized labor in regard to apprenticeship is doomed to failure. The same restrictions would inevitably be applied with equal force to the trade-school graduates. The trade school must demonstrate a larger value; it must demonstrate that it can perform the function of training beginners in certain trades more efficiently and on the whole more economically than this can be done in other ways, before it can take any large place as a factor in industrial training.

The industries in which the trade school would seem to have the largest actual possibilities are: first, in the machine and engine building trades, which demand some knowledge of drawing, elementary mathematics, and science for their full mastery and which open up exceptional chances of advancement

to the ambitious, intelligent, and inventive workman; and, secondly, in the building trades, where the conditions under which work is prosecuted make it particularly difficult to train beginners effectively in commercial practice. (14—46, 47)

96. New Schools to Meet New Conditions. With the increasing demands of manufacturers, labor leaders, and the public generally for more practical instruction in public schools and, with the lessening of the opposition to the expenditure of public funds to teach trades, a great variety of experiments in industrial education developed. In communities where the influence of labor unions was strong, efforts were chiefly toward providing some kind of preparatory trade or prevocational instruction for boys and girls under sixteen years of age while still in the public schools, and part-time improvement or industrial-continuation schools for those who had left the day schools and had become workers in the industries. In communities where the trade-union influence was not so strong, day-trade schools and part-time cooperative trade courses were established. The type of school to be started depended upon local conditions, especially with reference to manufacturing and labor interests, and the extent to which schoolmen and boards of education had overcome their prejudices against vocational education.

From this variety of experiment, a few more or less definite types of school were evolved or further developed during the ten years from 1907 to 1917. Among these were (a) the prevocational or industrial school, (b) the continuation school, (c) the part-time cooperative school, (d) the day vocational or trade school, and (e) the apprenticeship or corporation school.

(a) The elementary or intermediate industrial or prevocational school was intended to help solve the problem of the "wasted years" between fourteen and sixteen and provide education with an industrial bias parallel to that with an academic bias which was prevalent in the seventh and eighth, and sometimes the ninth, grades. Such industrial schools or departments were a very natural extension or enrichment of the public-school offering in these grades. They included

in their curricula the larger part of the studies for general culture and courses that were definitely preparatory to later trade or apprentice school work or to minor industrial occupations. Experimental instruction of this type began in the Agassiz School, Boston, in September, 1907. (15—95) One hour a day was given to industrial work. A fundamental difference between this new shopwork and the regular manual training was that "everything must conform as closely as possible to actual industrial work in real life. It was decided that the product must be not only useful, but must be needed and must be put to actual use (In this case it was used in the schools of Boston.); that it must be something which may be produced in quantities; that the method must be practical, and both product and method must, so far as possible, be subjected to the same commercial tests, as apply in actual industry." (15—97) In this experiment, while emphasis was placed upon shopwork, working drawings, and shop arithmetic, the election of this special course did not prevent a boy from going on to the high school if he was able to do so. Another example of this type of school was the Elementary Industrial School of Cleveland, Ohio, opened in 1909. In this school, half the time of a six-hour day was devoted to handwork, and the time devoted to each of the book subjects of the elementary school was reduced by two fifths and the instruction was related to the vocational interests of the pupils, not only those illustrated in the handwork of the school, but those pertaining to the commercial and manufacturing interests of the community. (15—103)

Still another school of this general type was the Shop School at Rochester, New York, opened in December, 1908. This school, like the two others mentioned, was not intended to teach a trade but "the fundamental principles pertaining to certain trades." Its aim was "to develop efficiency and rapidity in execution, so that those who go out with a diploma may be better fitted to enter their chosen trade than they would be under prevailing conditions." (15—131) In order to accomplish this, the school provided equipment and conditions resembling those found in factories. For this reason, the

school had more the air of a factory shop than a school shop. (15—132) At first, cabinetmaking was the shopwork course offered. Later, electrical work, carpentry, and plumbing were added, then architectural drawing and machine design. The length of the course was two years—forty weeks a year and thirty hours a week. The apportionment of time was: shopwork, 15 hours; shop mathematics, 5; drawing, 5; English, $2\frac{1}{2}$; industrial history, $1\frac{1}{2}$; and spelling, 1 hour. (15—131)

In discussing this general type of vocational training in 1909, Dr. James P. Haney said:

It is believed that the condition most essential to the success of a school planned to give this vocational training will depend on its establishment as a new and separate unit in the school system, one officered by a corps of instructors especially chosen because of their vocational knowledge and specific interest in the form of instruction to be given. The school should be one planned to perform a particular service. It should offer to the pupils the definite aim of vocational preparation, beginning some time before the completion of their compulsory school period and, by the practical nature of its teaching, striving to hold them after such period through the critical two years which follow. If the course of study is so organized, difficulties will be obviated, which would inevitably affect the success of a plan giving vocational training in the higher years of the elementary school, as at present organized, or in the lower years of a high-school course, extended downward into the grades. In either case, the vocational work would be incidental to the general curriculum, tacked on and loosely articulated with the regular course of study. The preparatory vocational school demands, on the contrary, that the vocational subjects be the center and core of its teaching. Both pupils and parents must see the school as one giving a preparation so direct and valuable to the future worker in the trades, that its graduate may count upon his knowledge as an immediate asset in securing him a shortened apprenticeship, and a speedier advance in wages.

Entrance into the preparatory-vocational school should naturally be offered as an elective; that is, the school should be organized in any district in a city in which the defection in the sixth and seventh years is now most marked, and should offer its courses to those pupils only who might choose to follow its curriculum rather than that of the grades as at present arranged. (16—27)

(b) The part-time cooperative school was one in which the pupils spent alternate weeks in school and in a commercially productive shop. The plan usually required that the boys work in pairs, one of the pair being in school while the other was in the shop. This plan was put in operation in teaching trades in 1908. In the spring of that year, Professor Herman

Schneider, dean of the college of engineering at the University of Cincinnati, explained to a group of metal manufacturers meeting in New York City his plan of cooperating with the manufacturers of Cincinnati in the training of engineers. Among those present on that occasion was Daniel Simonds of Fitchburg, Massachusetts, who was so favorably impressed with the plan that, on returning home, he talked it over with other manufacturers of the city and, with their approval, proposed to the school authorities that a similar plan be inaugurated between the high school and certain factories in Fitchburg. In order to insure a successful working out of the many details of the plan, it was considered essential that a technically trained man with shop experience be employed to act as coordinator. W. B. Hunter was secured for this new work, and he began to interview students early in August. Preference was given to boys who wished to follow the trades as a permanent occupation. Eighteen were chosen and at work by the opening of school in September. (17—7, 8)

The fundamental idea of the plan was to provide an opportunity for learning a trade or occupation and acquiring a secondary-school education at the same time. An agreement, corresponding to the indenture of an apprentice, was entered into between each boy's parents and the boy's employer. The course was four years in length. Each boy spent his school vacations working in the shop. Two months of shopwork during the summer before entering the school were intended to determine whether he was suited to the occupation he had selected. Boys received pay for their work on a graded scale agreed upon. The rate for these boys per hour was somewhat higher than had been commonly paid to apprentices, thus offering an inducement for a boy to get an education while learning a trade. (17—9)

An important contributing element to the success of the Fitchburg plan was the correlation of the school work with the shopwork in each trade. "From the first, the employers who offered their assistance demanded that the course be such as to make those going into it better mechanics, capable of advancing to the highest possibilities in the trade." (17—13)

Shop mathematics, mechanism of machines, and applied physical science occupied prominent places in these studies.

The part-time type of school which started in Fitchburg grew in popularity and appeared elsewhere with many modifications to suit local needs. It was adapted to clerical and mercantile as well as manufacturing occupations, to schools for girls as well as for boys. Notwithstanding its many details and difficulties in administration, it has appealed to educators as being superior to most other plans of vocational education. One great difficulty that has limited the plan has been the impossibility of finding positions for all who wanted such an opportunity of earning while learning. Moreover, the trade unions have been slow in giving their approval of the plan, or have made approval conditional.

(c) A continuation school, as the name implies, is a school where one who has left the full-time day school may continue his education. Under this inclusive definition, many public evening schools are continuation schools. Such schools have long existed. But under the impulse of the movement for vocational education, which is being considered in this chapter and, with the value of continuation schools in Europe, especially in Germany, being constantly emphasized, the term "continuation school" in America took on a new meaning, and the number and kinds of such schools increased rapidly. Some schools were organized to extend the *general* education of persons employed; many gave instruction related to specific industrial trades and other occupations; a few, with the necessary equipments, gave not only such related occupational instruction, but also broadening shop or laboratory experiences in the practical processes of specific industries, following the example of the industrial continuation schools of the city of Munich. (cf. 42) In several states, laws were passed making attendance upon continuation schools compulsory for boys and girls from fourteen to sixteen years of age, and requiring employers to release them to attend school a definite number of hours per week—usually from four to eight. For persons over sixteen, attendance was voluntary.

Successful continuation-school teaching, like the teaching in

the part-time cooperative school, takes advantage of every reasonable opportunity to build the instruction around the experiences of the individual pupils in their daily occupations. In this respect, continuation school teaching is often more effective than full-time school instruction for pupils of similar capacity. An example of good teaching in a continuation school in Cincinnati was reported thus:

The work done in the school is closely related to the work in the shop. For example, one of the first machines the boy becomes acquainted with is the drill press. In the school, the set of catalogs containing illustrations and descriptions of this machine is read by the class, the technical names of the parts are learned, and then other catalogs with other types of drill press are examined. A set of blueprints containing details of the feedbox is next studied, and the boys are encouraged to make freehand drawings, showing what the various lines mean to them. The discussion leads on to the various merits of the different types of machines, to scientific principles involved, and to the mathematical calculation of the speed of different spindles. This involves a problem in complex fractions which has been wholly forgotten by the boys. A lesson follows in arithmetic, and they, for the first time in their lives, take an intelligent interest in complex fractions. They are then given a carefully prepared sheet of problems and questions on the drill press which they work out and preserve in their course of study envelope. (18—222)

It should be observed that this problem, which, no doubt, occupied several lessons, involved reading, spelling, blueprint reading, drawing, study of mechanism, a bit of physical science, arithmetic, and composition: all as they are encountered in real life.

(d) Under the influence of the Vocational Education Movement, and especially when State aid was available, the full-time trade schools under public-school administration began to increase in number and change somewhat in form. In general, they gave more attention than formerly to the teaching of technical and other related subject matter and to education for citizenship. In general, such schools were intended to train skilled workmen before they entered upon employment. The earlier privately supported institutions were often looked upon with disfavor by trade unions; but, under public-school control and especially when union men were on advisory committees of the schools, they were ap-

proved and sometimes heartily supported. Not all full-time trade schools attempted to produce a few completely trained skilled workers; some preferred to give less complete trade preparation to a larger number of pupils. Two examples will illustrate these two types of schools for boys:

The Worcester Trade School, Worcester, Massachusetts, represents the complete training type. In 1910, it offered four-year courses in machinery, patternmaking, and cabinet-making. Completion of the work of the elementary school and evidence of mechanical aptitude were desired for entrance, with a minimum age of fourteen years. Work in the commercially productive shop of the school occupies half of the time. "Skill, speed, and appreciation of industrial demands, which are the requisites of the skilled workman, are gained by doing the commercial work." (15—191) In the other half of the time, considerable emphasis was placed upon the study of shop processes and in acquiring information related to the trade. Practical thoroughness has been a constant aim in this school. The management of the school was in the hands of the board of trustees elected by the city council. It was supported by city taxation and the State, each paying half of the cost.

Several good examples of the shorter-course trade school or trade-preparatory school were developed in Buffalo, New York, beginning in 1909. They were called vocational schools. In a few years, four such schools were giving two-year courses to hundreds of boys. The trades represented in these schools were automobile mechanics, cabinetmaking, carpentry, electrical construction, machine-shop practice, patternmaking, printing, and sheet-metal work. To motor-minded graduates of the elementary school, a choice of all these and the courses in the technical high school was offered. Half of the time in the six-hour school day was given to shopwork and half to such related subjects as drafting, mathematics, and science and to such more general subjects as industrial history, commercial geography, citizenship, hygiene, and English.

These schools were under the management and control of the Board of Education but partly supported by State funds.

For each trade course, there was "an advisory committee of four citizens, two representing organized labor and two representing employers. These committees helped to keep the schools in touch with the industries. (19—5)

(e) The corporation apprentice school is a fifth type of school that flourished under the Vocational Education Movement between 1907 and 1917. In large manufacturing corporations and railways, such schools flourished for a time. As previously stated (cf. 92) the initial motive force behind the starting of such schools in the railway shops was a paper read before the Railway Mechanics' Association in 1905. Almost immediately, the New York Central Lines put into operation a system of instruction based on the plan proposed. The Santa Fe, Delaware and Hudson, Delaware Lakawanna and Western, the Erie, and other railways followed. Likewise, during this same period, many large manufacturing corporations opened schools for their apprentices—International Harvester Company in 1906; The Western Electric Company and Yale and Towne Manufacturing Company in 1907; The Lakeside Press, and the Brown and Sharpe Manufacturing Company in 1908; Westinghouse Electric and Manufacturing Company in 1909. (8—146, 181)

Most of the schools of this type were maintained to give instruction in mathematics, mechanical drawing, and such elements of physical science as were related to the particular industry served. In many cases where the term of indenture was four years, the apprentices were required to attend school a few hours a week throughout the term of indenture. In other cases, school attendance was required for only two years. (8—145) The schools were usually in the employer's plant and the instruction what was needed for his particular work. All apprentices in a given works usually followed the same course of instruction irrespective of the trades they were learning. However, instruction was usually individual and adapted to the particular workshop needs of individual apprentices. The instruction in drawing was intended to develop ability to read drawings rather than to produce draftsmen.

In September, 1913, more than 100 men, interested in schools to increase the efficiency of employes, gathered in convention at Dayton, Ohio. They formed the National Association of Corporation Schools that exercised a powerful influence over apprentice schools until America became one of the belligerents in the World War, holding a convention each year and issuing an annual comprehensive report of proceedings. The number of corporation members in 1913 was 37. This number increased to more than three times that number. Industrialists of national and international fame served as officers, and leaders in industrial education cooperated. In 1913, the president was Arthur Williams of The New York Edison Company; first vice-president, E. St. Elmo Lewis of the Burroughs Adding Machine Company; and the second vice-president, Dr. Charles P. Steinmetz of the General Electric Company. Dr. Lee Galloway of New York University was the secretary. In 1914, Dr. Steinmetz was the president.

In 1913, a committee of this association presented a table of statistics concerning corporation apprentice schools that aroused much interest. In 1914, it was extended, revised, and again presented. It included returns from a questionnaire sent to 18 railroads, 37 manufacturing corporations, and 5 trade schools supported by public funds. Besides the statistics covering 49 items about students, courses, equipments, indentures, etc., the answers to ten questions were especially significant. From these, it was evident that every corporation believed that the benefits of an apprentice school would be sufficient to justify its expense. All but three thought that the public schools could not prepare boys for their shops without the aid of a "shop school." Nearly every corporation was willing to give apprentices from 2 to 5 hours a week of instruction, with pay for time spent in receiving such instruction. All but six favored the employment of a special instructor for the school rather than to require a shop foreman to teach the boys, but the instructor should be a "first-class practical mechanic." Concerning the question of whether the shop instruction should be given on "parts which go into

regular output" or on unproductive pieces "better suited to explain complicated operations," there was a difference of opinion. The majority favored the regular output; several recommended both; and two the unproductive work. The publicly supported trade schools favored the regular output. There was division of opinion also on whether all the instruction should be centered in the needs of the special industry maintaining the school or whether it should be more general in character. The majority wanted it broader than the particular applications to a single industry. (20—404)

In this connection, attention may well be called to the attitude of organized labor toward apprentice schools. In 1909, a committee of the American Federation of Labor, of which John Mitchell was chairman, made a report on industrial education that contained this paragraph:

It is of more than passing interest to note that a revival of apprenticeships by large corporate interests through comprehensive and sane regulations is gradually taking form. (21—10)

But in this same report is this caution:

Any scheme of education which depends for its carrying-out on a private group, subject to no public control, leaves unsolved the fundamental democratic problem of giving the boys of the country an equal opportunity and the citizens the power to criticize and reform their educational machinery. (21—12)

97. Vocational Guidance. The fact that the Vocational Education Movement aimed to fit boys and girls for specific occupations—to train them for definite skilled trades and jobs—brought about the necessity of their choosing between occupations and, consequently, between courses to pursue. This necessity for choosing, in turn, brought forward the idea of assistance in making such important choices, and gave impetus to a movement for vocational guidance. The movement started with an address by Frank Parsons before the Economic Club of Boston. On account of this, he was invited to speak to a graduating class of one of the evening high schools on the choice of a vocation. After the talk, a number of young men asked him for personal interviews. The

results gave evidence of being so helpful that Meyer Bloomfield, founder and director of the Civic Service House, asked him to draw up plans for the permanent organization of such a guidance service. The plans were submitted to Mrs. Quincy A. Shaw, to whom Boston had been indebted for funds to carry on several educational experiments. They met with her hearty approval, and The Vocation Bureau and Breadwinner's Institute was opened under Dr. Parsons's direction at the Civic Service House, Boston, in 1908. To this new center of helpful advice came "a large number of men and women from fifteen to seventy-two years of age." (22—91)

Among the applicants for advice were college students and young business men, but a majority of them were high-school students and working boys and girls of high-school age. The Bureau did not attempt to decide for any boy what occupation he should choose, but aimed to help him investigate and then come to his own conclusion. (22—92)

In his book, *Choosing a Vocation*, Dr. Parsons said, "In the wise choice of a vocation, there are three broad factors: (1) a clear understanding of yourself, your aptitudes, abilities, interests, ambitions, resources, limitations, and their causes; (2) a knowledge of the requirements and conditions of success, advantages and disadvantages, compensation, opportunities, and prospects in different lines of work; (3) true reasoning on the relations of these two groups of facts." (22—5)

Dr. Parsons died in 1908, but the work he had begun was continued. In 1909, Meyer Bloomfield organized the Vocation Bureau, of which he was the director until 1917. One of the first acts of this new bureau was to accept an invitation to cooperate with the Boston School Committee in developing a plan for making vocational guidance effective in the city schools. The Bureau made a study of the conditions in the trades and different kinds of business in Boston and published the results for the use of pupils, parents, and vocational counselors. It conducted a school for such counselors. It brought about cooperative effort among various organizations interested in guidance.

Thus began a movement that spread rapidly and has con-

tinued to grow in strength and influence. In November 1910, a national conference on vocational guidance was held in Boston, called by the Boston Chamber of Commerce in cooperation with the Vocation Bureau. The second conference was held in New York in 1912. This was spoken of as "an experience meeting." Many practical aspects of the movement were considered, including placement, follow up, study of occupations, scholarships, vocational analysis, opportunities for vocational training, methods of vocational direction, and relation of vocational guidance to the employer. The next year, a conference was held in Grand Rapids, Michigan, which resulted in the formation of the National Vocational Guidance Association. Frank M. Leavitt, of the University of Chicago, was elected president. During this same year, 1912, Professor Leavitt offered the first graduate course in vocational guidance to be given at an American university.

98. **State Legislation for Vocational Education.** The report of the Massachusetts Commission of 1906 and the work of the National Society for the Promotion of Industrial Education were so effective in arousing interest in the problems of industrial education that several states followed the example of Massachusetts. State commissions were appointed by Vermont, New Jersey, and Maryland in 1908, by Michigan in 1909, and by Maine in 1910; and in that same year Wisconsin appointed a legislative committee to investigate industrial and trade education. (23—27, 33) In the next few years, many states passed laws to encourage and aid vocational education. Massachusetts led the way in 1906 by authorizing the establishment of independent industrial schools, by providing State aid equal to one half of the local expenditures for such schools, and by the administration of vocational education through a commission independent of the State Board of Education. (23—11) In 1909, the work of the Commission was ended by transferring its duties and powers to a reorganized State Board of Education. (23—11) (15—272) Connecticut, beginning in 1907, passed laws which, in 1915, resulted in State-supported and -controlled day and evening trade schools. (24—23) New Jersey,

in 1909, amended laws allowing boards of education to establish schools for industrial education and providing State aid equal to local expenditures. (23—14) A more comprehensive law providing for day-school, continuation-school, and evening-school classes was passed in 1913. (24—24) A feature of the New York law of 1910 was that, in addition to authorizing general industrial schools for pupils who had completed the elementary schools or reached the age of fourteen years, trade schools for those who had attained the age of sixteen, continuation schools for employed workers over fourteen, and State aid, it provided for advisory boards of five members each, "representing the local trades, industries, and occupations." Such boards were to "counsel with and advise school authorities relative to schools and instruction." (25—699) Year by year, interest in the passage of laws in aid of vocational education spread from the industrial states of the East to the Middle West, and then largely because the laws contained provisions for the development of agricultural and home-economics education as well as industrial education, to the far West and to the South.

Of all the laws passed in states west of New York, none in the period under consideration were as complete as those enacted by the State of Wisconsin up to and including the law of 1911; none were as much quoted and discussed. As early as 1907, a statute was provided granting permission to any city or school district having within it a city to maintain a trade school for boys who had reached the age of sixteen. Such schools were to be under the management of the local school boards. In 1909, the age limit for trade schools was reduced to fourteen years.

The law provided that whenever such a trade school was established the school board "may appoint an advisory committee, to be known as the committee on trade schools, consisting of five citizens, not members of the school board, each of whom is experienced in one or more of the trades to be taught in the school or schools, to assist in the administration of the trade school or schools located in that city, which committee shall be appointed by the president of such school

board with the approval of the majority of the board. Such committee shall have the authority, subject to the approval and ratification of the school board, to prepare courses of study, employ and dismiss instructors, purchase machinery, tools and supplies, and purchase or rent suitable grounds or buildings for the use of such trade schools." (23—74) In order to further insure the practical and industrial character of the school, the school board was empowered to levy a tax of not over one-half mill on the assessed valuation of the city, and the funds so obtained could not be diverted to any other purpose.

The section of the law above quoted was the forerunner of the famous Act of 1911, creating what has been called the "dual system" of education—in plan somewhat similar to that tried in Massachusetts for the two years ending in 1909—in which the entire control of the vocational education of the State was placed in the hands of a State Board of Industrial Education and local boards of industrial education. This law created a State Board to be appointed by the governor. The board was to consist of six appointive members, three of whom were to be employers of labor and three skilled employes. The State superintendent of education, the dean of the extension department, and the dean of the college of engineering of the University of Wisconsin were to be *ex officio* members. This board was to control all State aid given under the Act. (15—287)

The law provided that, in every town or village or city of over 5,000 inhabitants, there was to be a local board of industrial education made up in a similar way to the State Board but by local school officials. Two of the appointive members were to be employers and two employes. No State aid was to be granted without the approval of the local board, and no money appropriated by the local community was to be spent for industrial schools without the approval of the local board of industrial education. The local board was to employ the teachers, do the purchasing for the industrial schools, and determine the tax to be levied for the support of the industrial schools. The course of study in such schools was

to be approved by the State superintendent of education and by the State Board of Industrial Education. (15—288-289)

The Wisconsin law of 1911 made provisions for apprentices and other employed children that were suggestive of the practice in Germany at that time. (cf. 42) Indentures were to meet certain requirements. Among them was one concerning time for instruction. Not less than five hours a week out of the total specified number must be allowed for instruction in English, citizenship, business practice, physiology, hygiene, the use of safety devices, and "such other branches as may be approved by the State Board of Industrial Education." This instruction might be given "in a public school, or in such other manner as may be approved by the local board of industrial education." (15—285)

Concerning the school hours for employed children, the law stated:

Whenever any evening school, continuation classes, industrial school, or commercial school, shall be established in any town, village, or city in this state for minors between the ages of fourteen and sixteen, every employer shall allow all minor employes over fourteen and under sixteen years of age a reduction in hours of work of not less than the number of hours the minor may by law be required to attend school. (15—286)

This law gave to Wisconsin a system of vocational education that could not be destroyed by the opposition of academic-minded schoolmen and one that gave employes an equal place with employers on controlling boards. From the standpoint of vocational education, it was regarded as safe and effective; but, from the standpoint of the leaders in general education, it was considered dangerous because it divided the taxing power and control of public education. Its success or failure appeared to be dependent upon the character and cooperative spirit of those who were to administer the law.

99. The National Vocational Education Law. As previously stated (cf. 94), the chief goal of the National Society for the Promotion of Industrial Education was to secure an adequate federal law providing national aid for industrial education. As early as 1908, at its first convention, the Society appointed a committee of ten educational leaders,

headed by Henry S. Pritchett, president of the Massachusetts Institute of Technology, to report upon the relation of industrial training to the general system of education in the United States. A preliminary report of the committee was made the next year at the Atlanta meeting, and the final report at the third convention held in Milwaukee. At this meeting, it was voted to send a copy of the report to the President of the United States, to the Vice-President, to the Speaker of the House of Representatives, and to the United States Commissioner of Education, calling special attention to the importance of "this whole matter of industrial education from the standpoint of our national and economic welfare," urging upon them "the duty of an adequate consideration of this subject by those responsible for the national progress," and recommending that an adequate appropriation be made to enable the United States Bureau of Education to investigate and report on the function of industrial education in the nation and its relations to the system of public instruction. (26—3, 4) The report suggested the kind of investigation needed and outlined it under three heads: (a) the industrial training of youth, (b) schools for men and women already in the trades, (c) the social significance of industrial education.

Previous to this time, 1907, U. S. Representative Charles R. Davis of Minnesota had introduced a bill in Congress calling for annual appropriations from the national treasury for maintaining instruction in agriculture and home economics in secondary agricultural schools and instruction in mechanic arts and home economics in city secondary schools. In opposing this bill, U. S. Commissioner of Education Elmer Ellsworth Brown, with the support of both the National Society's report of the committee of ten and a resolution of the National Education Association, contended that, before such a bill should be approved, a study should be made of the whole problem, and a bill framed in conference with experienced school superintendents. (24—59) By 1909, the American Federation of Labor entered the controversy in Washington, expressing approval of the idea of federal aid

for industrial education. Its special committee revised the Davis bill and gave it to Senator Jonathan P. Dolliver of Iowa, who introduced it in the Senate. (24—60) By the next year, the agricultural and labor interests had been lined up in favor of the Davis-Dolliver bill, and the support of the

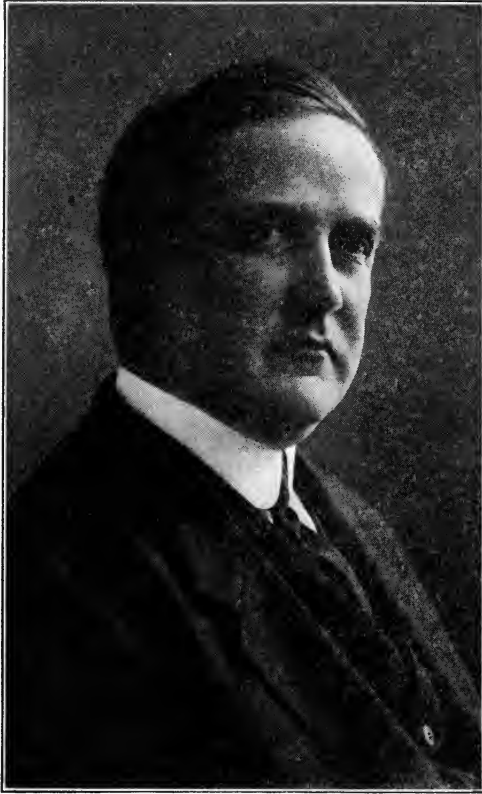

FIG. 140. CHARLES A. PROSSER

National Society for the Promotion of Industrial Education was sought. The National Society, however, refused to support the bill, and continued to believe that an investigation of the whole subject should be made. Early in 1911, the executive committee of the Society made the following definite statements that revealed some of the weaknesses of the Davis-Dolliver bill:

We highly commend the general spirit and purpose of Senate bill 8809 (Dolliver bill). We have, however, grave doubts as to whether the bill as at present drawn will accomplish the purposes in view. It should be modified by the introduction of specific terms to the end that it shall clearly provide:

1. For cooperation on the part of the Federal Government with the several States of the Union in encouraging vocational education in the trades and industries, agriculture, and home economics; in founding agricultural experiment stations; and in providing means for the training of special teachers for industrial, agricultural, and home-economics education;

2. For a definite limit to the amount of money appropriated under this act by the United States Government for each of the above-named purposes; and for an equitable means of distributing the sum appropriated among the several States in proportion to their approximate probable needs;

3. For the gradual availability of the sums appropriated to the end that the maximum limit may be reached only after a period of from 6 to 10 years;

4. For the contribution from each State of a sum equal to that contributed to said State by the Federal Government;

5. For a restriction limiting the use of the Federal contribution and the equal State contribution to the defraying of the expenses of instruction in these branches of study which the bill is intended to encourage, to the end that no part of said sum shall be used for general purposes;

6. For a provision permitting each State to propose the type and location of the schools in which vocational training is to be established, on condition that such proposal be approved by a properly constituted Federal authority;

7. For a requirement that each State shall propose its own methods of supervising any educational agencies established under the provisions of this bill, provided said methods of supervision shall be duly approved by a properly constituted Federal authority;

8. For a careful definition of the terms used relating to forms of education and experimentation, to the end that ambiguities and misunderstandings may be avoided;

9. For adequate Federal supervision that shall insure satisfactory results from the school established. (24—66, 67)

After the death of Senator Dolliver, Senator Carroll S. Page of Vermont became the Senate leader in promoting industrial education. He introduced a bill expressing his views in April 1911. In November of that year, the National Society for the Promotion of Industrial Education expressed general approval of the objects of the Page bill and suggested some improvements, especially with reference to its administration. (24—73, 74) These suggestions, however, were ignored in revising the bill. (24—76) It now became evident that, if the National Society was to accomplish its purpose, it must do some more effective work in Washington. At this juncture, it

was decided to induce Dr. Charles A. Prosser, Fig. 140, deputy commissioner of education for the State of Massachusetts, to become the secretary of the Society. He accepted the offer and went to Washington in March to help draft a new Page bill. A few months after this, Senator Page delivered a speech in the Senate, reviewing the legislative efforts for vocational education, which was reprinted and widely distributed. It quoted statements made by representatives of such organizations as the National Association of Manufacturers, The American Federation of Labor, and from numerous educators and other leading citizens. (27—45, 69—132)

While trying to help shape legislation in Washington, the National Society continued its educative efforts elsewhere. Especially, it sought to bring about State legislation in harmony with what it was advocating for federal aid. At the Philadelphia meeting in 1912, a statement of principles and policies was made that, from the viewpoint of the National Society, should underlie State legislation. This was approved by the official board and published in pamphlet form. In promoting the principles and policies in this statement, Dr. Prosser went from state to state as needed to help in shaping legislation, and through his legal knowledge, experience in Massachusetts, enthusiasm for vocational education, and exceptional ability as a public speaker, wielded a great influence upon legislative bodies.

Notwithstanding the general support of the Page bill, there were powerful interests that caused delay and insisted that the Smith-Lever agricultural extension bill be given precedence over the vocational education bill. A legislative deadlock followed. The Smith-Lever bill finally passed in January, 1914.

The next forward step was taken when Congress passed a resolution creating the Commission on National Aid to Vocational Education. Senator Hoke Smith of Georgia was made chairman of the Commission. The other Congressional members were Senator Page, Representative D. M. Hughes, and Representative S. D. Fess. To these were added five leaders

in the movement for vocational education, including Dr. Prosser. The two-volume report of this Commission discussed (a) the need of vocational education, (b) the need of national grants to the States, (c) kinds of vocational education for which national grants should be given, (d) aid to vocational education through federal agencies, (e) extent to which the national government should aid vocational education, (f) conditions under which grants for vocational education should be given, and (g) proposed legislation. To the discussion of these subjects were added supporting data, including hearings, statements from letters, and statistics.

The Commission recommended that national grants be made to the states (a) for training teachers of vocational subjects, (b) for paying part of the salaries of teachers of vocational subjects; and that appropriations be made to a federal board for making studies and investigations which should be helpful to vocational schools. The kinds of schools aided were to be (a) those "supported and controlled by the public," (b) "less than college grade," and (c) "designed to prepare boys and girls over fourteen years of age for useful or profitable employment in agriculture and in trades and industries." These should be of three types:

- a. All-day schools in which practically half of the time should be given to actual practice for a vocation on a useful or productive basis.
- b. Part-time schools for young workers over fourteen years of age, which should extend either their vocational knowledge or give preparation for entrance to a vocation, or extend the general civic or vocational intelligence of the pupils.
- c. Evening schools to extend the vocational knowledge for mature workers over sixteen years of age. (28—I, 14, 15)

To these recommendations were added paragraphs on the amount of the grants, administration of the law, and safeguarding conditions. Included in the report also was the draft of a bill embodying the recommendation of the Commission. (28—82—87) Although the report was received by Congress June 1, 1914, it was not brought forward for final action until the President urged its passage in January, 1916. Then it came as a new bill presented by Representative Dudley M. Hughes and it included home-economics education in addition

to the previously designated industrial education for women. Moreover, it took a conciliatory step toward meeting the objections of the National Education Association by changing the Federal Board for Vocational Education so as to include the United States Commissioner of Education and four citizens representing the special interests behind the bill, instead of being made up entirely of members of the President's cabinet. In this form, the bill now received the endorsement of the Department of Superintendence of the National Education Association, and the American Home Economics Association. (24—102, 103)

Another factor in shaping public sentiment was the work of the Vocational Education Association of the Middle West, holding large annual conventions in Chicago. Soon after the Richmond convention of the National Society for the Promotion of Industrial Education in December, 1914, a strong feeling was developing that, in the Mississippi Valley, there was need for an organization that would serve as a clearing house for debatable issues on vocational education. The National Society was supported and controlled by eastern men, and its programs did not give sufficient attention to some questions that were considered vital to the interests of public-school education in the Middle West. Action on account of this feeling was taken when Albert G. Bauersfeld and William Bachrach of Chicago, with Wilson H. Henderson of Milwaukee, discussed the matter with William J. Bogan, then principal of the Lane Technical High School, and secured his leadership. More than 600 people attended the first meeting held in Chicago in February, 1915. Most of the discussions at that and at subsequent meetings of the Association were focused on the various problems of relationship between vocational education and the public-school system. Under the leadership of Mr. Bogan, and with the support of nearly every leader of thought on vocational education in the Mid-West states, this Association did just what it aimed to do—provide a public forum for the discussion of vital topics on vocational training in its relation to public education. Leaders from the East as well as the West, and representing

widely different points of view, were brought together in an effort to solve a great social-educational problem in the wisest way.

An important climax was reached in the discussion of the Smith-Hughes act after the United States Chamber of Commerce took a nation-wide referendum vote on the subject of vocational education in 1916. This resulted in what was approximately a seven-to-one vote in favor of the provisions of the Smith-Hughes bill. Lloyd E. Blauch, in his *Federal Cooperation*, says of it:

The referendum was undoubtedly a master stroke. It showed the attitude of an important and influential group as to whether its members desired federal aid for vocational education, as well as their attitude on the constitution of the Federal Board for Vocational Education. It was a mandate of no mean importance. The result of the referendum was sent to all senators and representatives to guide them in their interpretation of the attitude of the citizens on the question. (24—104)

Another delay and then an urgent demand for early action from the President, and the Smith-Hughes bill passed and was signed by President Wilson on February 23, 1917.

Meanwhile Dr. Prosser had left the secretaryship of the National Society in 1915 to become the director of Dunwoody Institute in Minneapolis, and Alvin E. Dodd had succeeded him. It was therefore Mr. Dodd who represented the National Society in the final effort to bring about harmony of action. Three days after the bill became a law, Senator Page sent a letter to Secretary Dodd, in which he said:

Accept my heartiest congratulations on the passage of the great measure for which your organization has struggled so long and faithfully—the measure providing for Federal aid for vocational education.

After many years of strenuous work, the bill has passed both Houses without a dissenting vote and has been approved by the President. Your organization will agree with me, I am sure, that, measured by its immense importance to the boys and girls of this country, it is incomparably the most important piece of constructive legislation passed by Congress in this generation. (29—XVIII, 348)

At the time the Smith-Hughes bill was signed by the President, the National Society for the Promotion of Industrial Education was in session at Indianapolis. The news

flash from Washington was received with jubilation. The chief goal of the National Society had been reached.

Blauch says of the work of the National Society: "So well was the activity of the Society managed that practically all its principles were written into the bill and, due to the campaign conducted by the organization, the bill became a law. It is very doubtful whether a federal law on vocational education in secondary schools would have been enacted as early as 1917 if the Society had not taken a leading part in promoting the legislation." (24—131)

The signing of the Smith-Hughes act, thereby creating a federal directing and reimbursing law with reference to certain types of vocational education, was the beginning of a new era in manual and industrial education in the United States and therefore the end of the era concerning which this book was written. Throughout the years of effort to obtain the law, there were three constantly recurring and conflicting interests that had to be harmonized or at least propitiated. One was between the manufacturer and the labor union; each wished to regulate vocational training in order to control the labor market. Then there was the conflict of ideals between those who sought more practical education in the public schools and those who feared that vocational training would lower the standard of cultural education. And finally, when the need for vocational training was admitted, some believed that it could be effective only when separated from the public-school work of general education; while others insisted on the unity of control in public education and saw no good reason for a dual system. The law passed was probably the best compromise that could have been obtained at that time.

SOURCE REFERENCES

1. *Industrial Education*. Eighth Annual Report of the U. S. Commissioner of Labor, 1892.
2. Catalogue—New York Trade School, 1897-1898.
3. *Fifty Years of Learning Thru Doing*. The Fiftieth Anniversary of the Founding of the Hebrew Technical Institute, 1934.
4. Annual Report of the Hebrew Technical Institute, New York, 1889.

5. *The California School of Mechanical Arts*. Circular of Information, San Francisco. 1895.
6. Eighth Annual Report of the U. S. Commissioner of Labor, Washington, 1892.
7. Clarke, Isaac Edwards. *Art and Industry: Education in the Industrial and Fine Arts in the United States*. U. S. Bureau of Education, Washington, 1897.
8. *Industrial Education*. Twenty-fifth Annual Report of the U. S. Commissioner of Labor. Washington, 1910.
9. Warner, Charles F. "Development of Industrial and Technical Instruction in Evening Schools." *Industrial Education Magazine*. The Manual Arts Press, Peoria, Illinois.
10. Transactions of American Society of Mechanical Engineers, Volume XXI.
11. Report of the Commission on Industrial and Technical Education. State of Massachusetts, 1906.
12. Second Annual Report of the Commission on Industrial Education, State of Massachusetts, 1908.
13. Bulletins issued by the National Society for the Promotion of Industrial Education. Beginning in January, 1907.
14. *Industrial Training*, Part I of Twenty-sixth Annual Report of the Bureau of Labor Statistics. State Department of Labor, Albany, 1909.
15. Leavitt, Frank M. *Examples of Industrial Education*. Ginn and Company, Boston, 1912.
16. Haney, James Parton. "Vocational Training and Trade Teaching in the Public Schools." "Industrial Education." The Annals of The American Academy of Political and Social Science, Vol. XXXIII, No. 1, January, 1909.
17. McCann, Matthew R. *The Fitchburg Plan of Cooperative Industrial Education*. Bulletin, 1913, No. 50. U. S. Bureau of Education.
18. Leavitt, Frank M. "The Continuation School: Cincinnati's Examples." *Vocational Education*, Vol. II, 1913.
19. *Vocational Education for the Industries*. Pamphlet issued by the Board of Education, Buffalo, New York, 1919.
20. *Report of Second Annual Convention*, The National Association of Corporation Schools, 1914.
21. *Industrial Education*. Reports published by American Federation of Labor, 1910.
22. Parsons, Frank. *Choosing a Vocation*. Houghton Mifflin Company, Boston, 1909.
23. Elliott, Edward C. and Prosser, C. A. *Legislation upon Industrial Education in the United States*. Bulletin No. 12, National Society for the Promotion of Industrial Education, 1910.
24. Blauch, Lloyd E. *Federal Cooperation in Agricultural Extension Work, Vocational Education and Vocational Rehabilitation*. Bulletin, 1933, No. 15. U. S. Office of Education.
25. Hood, William R. *Digest of State Laws Relating to Public Education*. Bulletin, 1915, No. 47, U. S. Bureau of Education.
26. *Report of the Committee of Ten on the Relation of Industrial Training to*

- the General System of Education in the United States.* National Society for the Promotion of Industrial Education, 1910.
27. *Vocational Education.* Speech delivered in the U. S. Senate by Hon. Carroll S. Page, June 5, 1912. Government Printing Office, Washington, D. C.
28. *Vocational Education.* Report of the Commission on National Aid to Vocational Education. 2 vols. Government Printing Office, Washington, 1914.
29. *Manual Training Magazine.* The Manual Arts Press, Peoria, Illinois.

SIGNIFICANT DATES ¹

. Before 1870

PAGE

ENGLAND	1788 Philanthropic Society founded in England to establish industrial schools 226	226
1851 World's Fair in London—the great awakening 276	276	
1853 National Training School of Art, London 278	278	
FRANCE	1799 First National School of Trades and Industries in France. . . 160	160
1829 Central School of Trades and Industries founded in Paris . . . 160	160	
1832 School workshops installed in Paris by César Fichet 108	108	
1845 Manual instruction in 15 elementary schools in Paris 108	108	
1865 Report of National Commission on Technical Education 109	109	
GERMANY	1865 Industrial Art School opened in Nuremberg 210	210
OTHER EUROPEAN COUNTRIES	1846 Sweden—Association formed to extend instruction in sloyd . . . 55	55
1863 Finland—Normal school established by Cygnaeus 58	58	
1868 Russia—System of tool instruction developed by Della Vos in Imperial Technical School at Moscow 15	15	
AMERICA	1868—Washburn Shops offer instruction in the mechanic arts . . . 311	311

¹This list of dates has been selected in order to focus attention on certain events that seem to be of special significance as one studies cause and effect in the development of manual and industrial education.

SIGNIFICANT DATES

From 1870 to 1880

PAGE

		PAGE
ENGLAND	1870 School Boards in England empowered to provide special education for juvenile delinquents	226
	1878 City and Guilds of London Institute founded	280
FRANCE	1873 Salicis School opened in Paris	110
	1873 Diderot School opened in Paris	109, 154
	1878 Russian system of tool instruction shown at Paris Exposition	42
	1879 Corbon report on manual training in public elementary schools for France	122, 135
	1879 Tolain report on a system of apprenticeship schools for France	147, 166
GERMANY	1874 Compulsory continuation schools in several German states	195
OTHER EUROPEAN COUNTRIES	1872 Sweden—National grant of 2,500 crowns annually for sloyd schools	61
	1872 Sweden—Abrahamson establishes sloyd school at Näås	61
	1873 Austria—Russian system of tool instruction displayed in Exposition at Vienna	42
	1874 Bohemia—Royal Mechanic Arts School opened at Komotau	43
	1877 Sweden—Otto Salomon visits Cygnaeus in Finland	64
	1878 Sweden—Educational sloyd developed by Otto Salomon	65
	AMERICA	1871 "The Whittling School" opened in Boston
1874 Industrial courses at the Kansas State Agricultural College		314
1876 Russian system of tool instruction shown at Centennial Exposition at Philadelphia		320
1876 School of Mechanic Arts established at the Massachusetts Institute of Technology of Boston		322
1877 Professor C. M. Woodward described his vision of a new realm in education		336

SIGNIFICANT DATES

From 1880 to 1890

PAGE

ENGLAND	1882	Drawing inspector appointed for London	225
	1883	London Parochial Charities Act passed, leading to the development of the famous London polytechnics	285, 289
	1883	School Board of Manchester began manual training in two elementary schools	234
	1884	Birmingham established a "seventh standard technical school"	234
	1884	Report of the Royal Commissioners on Technical Instruction, England	238
	1885	Manual Training School opened at Manchester Technical School	232
	1885	Shopwork begun in Beethoven Street School, London	236
	1887	"Joint Committee" appointed in London	240
	1887	Classes in manual training for teachers opened in London	261
	1887	The National Association for the Promotion of Technical and Secondary Education organized in England	293
	1888	Arts and Crafts Exhibition Society formed in England	298
	1888	Manual training begun in six London centers under "Joint Committee"	241
	1888	Sloyd Association of Great Britain and Ireland organized	260
	1889	Technical Instruction Bill passed, permitting the use of public funds for manual instruction	242
FRANCE	1880	Law creating a new type of national apprenticeship or industrial school for France	149
	1881	Manual training recommended for all grades up to the end of the intermediate schools	122
	1882	Manual training an obligatory subject in France	140
	1888	Commission appointed to revise manual-training system in Paris	123
GERMANY	1880	Clauson-Kaas gave a course in domestic industry for teachers at Emden	171
	1881	Formation of German Central Committee for Instruction in Manual Dexterity and Home Industry	174
	1882	Extensive exhibit of school shopwork held at Leipsic	174
	1886	German Association for Boy's Handwork organized	175
	1886	College for training teachers of manual training established	175
	1886	Magazine for the promotion of manual training in Germany published at Leipsic	179

SIGNIFICANT DATES

From 1880 to 1890 (continued)

PAGE

OTHER EUROPEAN COUNTRIES

1881	Denmark—Ansel Mikkelsen began to teach manual work to his apprentices	98
1882	Sweden—Sloyd school at Nääs entirely devoted to training teachers	64
1882	Sweden—Director of sloyd appointed for the City of Stockholm	88
1886	Denmark—Danish Sloyd Association organized	98

AMERICA

1880	St. Louis Manual Training School opened	351
1880	Workingman's School opened in New York City	417
1881	<i>Woodworking Tools: How to Use Them</i> , America's first textbook on school-shop woodworking, published	406
1881	New York Trade School opened	507
1882	"Dwight School experiment" in Boston	409
1882	Montclair, New Jersey, began to teach manual training in the elementary schools at public expense	419
1882	Manual training began at Jamestown, New York	421
1884	Notable exhibit of manual-training work at meeting of National Education Association	362
1884	First publicly supported manual-training high school opened in Baltimore	374
1884	Industrial Education Association organized in New York City	413
1886	Children's Industrial Exhibition in New York City	414
1887	<i>The Manual Training School</i> by C. M. Woodward published	359
1887	<i>Industrial Education</i> by Samuel G. Love published	422
1888	Gustaf Larsson, advocate of Swedish sloyd principles, came to Boston	431

SIGNIFICANT DATES

From 1890 to 1900

PAGE

ENGLAND	1891 National Association of Manual Training Teachers organized	259
	1892 <i>Hand and Eye Magazine</i> published	260
FRANCE	1891 Course of instruction for manual-training teachers adopted in Paris	132
	1892 New system of manual training adopted in Paris	123
	1892 National vocational schools provided for in France under the Ministry of Commerce and Industry	151
GERMANY	1891 Law in Germany required employers to grant workers under 18 years time to attend continuation classes	195
AMERICA	1893 Professional courses for teachers of manual training at Teachers College, New York	468
	1893 Many manual-training exhibits at Columbian Exposition, Chicago	434
	1893 Manual Training Teachers' Association of America organized at Columbian Exposition in Chicago	496
	1893 Western Drawing Teachers' Association organized at Columbian Exposition in Chicago	499
	1896 Course in the theory and practice of manual training accepted as graduate work at Columbia University	470
	1897 Society of Arts and Crafts organized in Boston	441
	1898 Technical High School established at Springfield, Massachusetts	384
	1899 Milton P. Higgins proposed a "half-time" school to train for the industries	512
	1899 <i>School and Society</i> by John Dewey was published	451

SIGNIFICANT DATES

From 1900 to 1917

PAGE

ENGLAND	1901 <i>Manual Training Teacher</i> first published	260
FRANCE		
GERMANY	1900 Workshops for wood and metal in all eighth-grade classes for boys in Munich—six hours a week	184
	1900 New type of industrial continuation school opened in Munich	201
	1904 Prussia required classes in compulsory continuation schools to be held during the daytime	195
	1909 Fifty-four industrial continuation schools in Munich	201
AMERICA	1901 Boston course in manual training for seventh, eighth, and ninth grades published	435
	1901 Council of Supervisors of the Manual Arts organized	502
	1903 Dr. Lorenzo D. Harvey becomes director of Stout Training Schools, Menomonie, Wisconsin	484
	1906 Report of the Massachusetts Commission on Industrial Education	513
	1906 National Society for the Promotion of Industrial Education organized in New York City	517
	1907 Intermediate industrial schools organized	528
	1908 Part-time cooperative schools begun	531
	1908 First meeting of The Manual Arts Conference	503
	1909 <i>Choosing a Vocation</i> by Frank Parsons published	538
	1909 Report on Industrial Training in New York State	521
	1911 Vocational education law in Wisconsin	540
	1912 National Society for the Promotion of Industrial Education employed Dr. Charles A. Prosser to assist in promoting State and national legislation for vocational education	546
	1913 National Association of Corporation Schools organized	536
	1913 Article by Dr. Frederick G. Bonser in <i>School Arts Magazine</i>	453
1917 Smith-Hughes vocational education act signed by President Wilson on February 23	549	

INDEX

- Abrahamson, August, school at Nääs, 61
- Adler, Felix: 416; believed in industrial work in education, 418; founder of first free kindergarten in America, 417; "hand education a part of school education," 456-459; introduces the "creative method," 417; opposes trade training, but approved technical and art instruction, 363
- Allen, Charles R., 517
- American Federation of Labor, attitude of, toward vocational education, 537, 543, 546
- "American Sloyd," 432
- Analysis of processes: Russian, 13; Swedish, 65
- Anderson, Newton M., 390
- Apprenticeship, complete substitute for, 204, 216
- Apprenticeship method not satisfactory, 15
- Apprentice schools, corporation, 535
- Arts and Crafts Exhibition Society, 298
- Arts and Crafts Movement in America, 441
- Associations: American Manual Training Association, 496; Boston Manual Training Club, 505; The Council of Supervisors of Manual Arts, 502; Eastern Art and Manual Training Teachers' Association, 498; Eastern Arts Association, 499; Eastern Art Teachers' Association, 497; Eastern Manual Training Association, 496; Educational Handwork Union, England, 261; German Association for Boys' Handwork, 173-175; Illinois Manual Arts Association, 505; Industrial Art Teachers' Association, 492; Industrial Education Association; New York City (organized, 1884), 412; Industrial Education Department of the National Education Association, 493; Industrial School Association, Boston, 406; Institute of Handicraft Teachers, England, 261; The Manual Arts Conference, 502; Manual Training Teachers' Association of America, 496; National Association of Corporation Schools, 536; National Association of Manual Training Teachers, England, 259; National Association of Manufacturers, 546; National Association for the Promotion of Technical and Secondary Education, England, 293; National Vocational Guidance Association, 539; Northern Counties Sloyd Association, England, 261; Pacific Manual Training Teachers' Association, 505; The School Crafts Club, New York, 505; Sloyd Association of Great Britain and Ireland, 259; Vocational Education Association of the Middle West, 548; Western Arts Association, 501; Western Drawing and Manual Training Association, 500; Western Drawing Teachers' Association, 499
- Auchtmuty, Richard T., 507
- Bachrach, William, 548
- Bailey, Henry Turner, 502
- Ball, Frank H., 482
- Balliet, Thomas M., 511
- Bamberger, Gabriel, 418
- Barker, James F., 386
- Barnard, Charles A., 414
- Barney, Edgar S., 510
- Barter, Solomon, 241
- Bartlett, George H., 498

- Basic considerations in organizing continuation schools, 215
 Baumann, A., 392
 Bowden, William T., 504
 Belfield, Henry M., 373
 Bennett, Charles A., 380, 468, 487, 502, 504
 Biederman, Friedrich Karl, 170
 Bismarck's purpose in Germany, 193
 Blake, Anna, S. C., 479
 Bloomfield, Meyer, 538
 Bogan, William J., 386, 548
 Bonser, Frederick G.: 489; expanded conception of industrial arts in elementary education, 453-455
 Booth, E. R., 380
 Bowler, Mrs. E. F., 493
 Boyden, A. G., 464
 Bradley, Mrs. Lydia, 486
 Brodhead, John C., 505
 Bryan, Anna E., 450
 Building Trades School, Breslau, Germany, 208
 Bumann, A. M., 478
 Butler, Nicholas Murray: president of New York College for the Training of Teachers, 467; said that manual training is mental training, 369
 Buxton, George F., 485, 504
 Cabinetmaker's School in Berlin, 209
 Carter, Charles M., 493
 Carter, Joseph, 389, 424
 Centennial Exposition in Philadelphia (1876), 42
 Chamberlain, Arthur H., 483, 505
 Chamberlain, John A., 393
 Chaney, George L., 404
 Children's Industrial Exhibition in New York City, 414
 Churchill, Alfred V., 498
 City and Guilds of London Institute proposed the "joint committee," 241
 Clark, John S., both industrial and literary training needed, 361
 Clauson-Kaas: in Germany, 171; leader in domestic industries, 97
 Colby, E. C., 493
 Columbian Exposition, Chicago (1893), 42
 Comfort, Benjamin F., 388
 Continuation schools, 532
 Corbon report, France, 136-140
 Correlation sought through regular classroom teacher, 128
 Crawford, Robert, 375
 Crawshaw, Fred D., 491, 504
 Cygnaeus, Uno: 57; belief in handwork, 58; director of education, Finland, 58; handwork a fundamental subject, 59; insisted sloyd teacher should be a school teacher, 64; principal of Finnish school, 57; in Russian America, 57
 Daniels, Fred H., 498
 Davis, Solon P., 498, 502
 Dean, Noah, 318
 Decker, W. F., used printed lesson sheets, 394
 Della Vos, Victor, 14, 48
 "Developing school" proposed, 407
 Dewey, John, 489; helped change kindergarten, 450
 Dickinson, John W.: 429; public schools not to teach trades, 365
 Dodd, Alvin E., 549
 Dodge, Grace: first woman member of New York City Board of Education, 415; leader in industrial education, 412-416
 Domestic industries: 54; Danish Society for, 97
 Dow, Arthur W., 498
 Dow, C. H., 407
 Dutton, Samuel T., 423
 Eddy, Benjamin F., 432, 438
 Elementary industrial schools, 528-530
 Ellis, Harry, 384
 Emmerich, Charles E., elective system applied, 383
 Erikson, Lars, 430
 Ewing, Emma P., 376
 Fairchild, George T., 367, 494
 "Fitchburg plan," 531
 Foley, Thomas, 330
 French Commission of 1865, 14
 Fuches, Otto, 493
 Gladden, Washington, industrial training, 413
 Goetze, Dr. Waldemar, 172

- Gompers, Samuel, 519
 Grady, Richard M., 374
 Griffith, Ira S., 443
- Hackley Manual Training School, 382
 Hall, G. Stanley, 439, 450
 Hall, James, 498, 502
 Ham, Charles H., pointed to defects in public schools, 369
 Haney, James Parton, 441, 502, 505, 517, 530
 Hanus, Paul H., 515
 Harris, William T: approved vocational training, 362; leading advocate of kindergarten, 445; paper on "The Intellectual Value of Tool Work," 371; read notable paper on "Psychology of Manual Training," 370
 Harvey, Lorenzo, 484
 Hatch, W. H., 443
 Hawkes, Timotheus T., 317
 Hemenway, Mrs. Augustus, 411
 Henderson, Wilson H., 548
 Herrick, Elizabeth A., 468
 Hervey, Walter L., 467
 Higgins, Milton P., 518; advocated the half-time school, 512
 Hill, Frank A., 384
 Hitchings, Henry, 493
 Hogg, Quentin, 285
 Holmes, Mrs. E. C., 426
 Hood, Ozni P., 317
 Hovey, Marion, 406
 Howe, Charles B., 496
 Hoyt, Deristhe L., 493
 Hughes, D. M., 546, 547
 Hunter, W. B., 531
 Huntington, Emily, 412
 Huxley, Thomas Henry, 222
- Imperial Technical School, Moscow: 14, 48; visit of Charles O. Thompson to, 50
 Industrial Art School, Philadelphia, 428
 "Industrial Arts," term suggested by Charles R. Richards, 453
 Industrial Education Association, New York City, objects of, 413
 Industrial schools in England, 226
- Jacobson, Augustus, manual training "bread-winning training," 363
 Jolley, A. R., 424
 Judd, Joseph H., 269
- Kerschensteiner, Georg: 184, 197-204; basic considerations in organizing continuation schools, 215; in America (1910), 521
 Kilbon, George B: 428, 496; author of book on "knifework," 449
 Kimmins, C. W., 303
 Kitchen garden, 412
 Kunou, Charles A., 431, 483
- Larsson, Gustaf, 431, 472, 475
 Laughlin, Ada M., 499
 Leavitt, Frank M: 432, 435; 539; at University of Chicago, 489
 Leblanc, René, 123
 Leipsic Boy's Workshop, 172
 Leipziger, Henry M., 509
 Leland, Charles Godfrey, 427
 Lethaby, W. R., 300
 Lick, James, 510
 London Polytechnics, 284-290
 Love, Samuel G: 421; author of an early book on manual training, 422
 Lubbock, Sir John, 238
- MacAlister, James: brought about manual training school in Philadelphia, 375; said that manual training trains to *do* as well as to *think*, 365
 Macy Manual Arts Building, 470
 Magnus, Sir Philip, 239, 259, 280
 Main, Charles T., 330
 Manchester Technical School, 231
 Manual Arts, early use of the term, 441
 Manual Element in Education, The, by John D. Runkle, 340-346
 Manual Training Controversy (1880-1890), 360-373
 Manual training course of study for New York City (1888), 415
 Manual training in England: associations of teachers, 259; background, 220; beginning Swedish sloyd in London, 243; Birmingham, 234; Central School, Sheffield, 233; Code of 1890, allowing woodwork instruction in elementary schools, 242; cyclo-

- pedia of handwork, 267; defined, 246; Elementary Education Act of 1870, 224; elementary handwork, 265; industrial schools for poor and unfortunate children, 226; inspectors of needlework and drawing, 225; in a London Board school, 235; London School Board favors manual training in 1888, 243; in London, under the "joint committee," 240; 270-273; magazines, 260; in Manchester elementary schools, 234; in Manchester Technical School, 232; pioneer book on woodwork, 245; shopwork in Allan Glen's Institute, 229; shopwork at the University of Cambridge, 230; shopwork in Bedford Grammar School, 227; shopwork in the Uppingham School, 228; teaching devices, 258; training and certification of teachers, 261-265; typical course of instruction, 249-258; typical manual-training equipments for woodwork and metalwork, 249-258
- Manual training in France: artisan teachers and regular class teachers in Paris, 122, 128; Carbon report of 1879, 122, 136-140; early shopwork in Paris schools, 108; general method in Paris under supervision of A. Jully, 129, 142-145; historical background, 107; program for elementary schools, 122; Salicis School in Paris, the pioneer manual-training school, 110-121; special commission under Salicis and Leblanc, 123, 141; training teachers, 131-135
- Manual training in general high schools: Cleveland Manual Training School, 390; Cleveland, West Manual Training School, 392; Eau Claire, Wisconsin, 389; Minneapolis, 394; Omaha, 392; Peru, Illinois, 389; Washington, D. C., 393
- Manual training in Germany: beginning of the Movement, 171; college for teachers at Leipsic, 175; course of instruction advocated by Dr. Goetze, 177; eighth-grade program in Munich, 184-190; exhibition at Leipsic in 1882, 174; German Association for Boys' Handwork, 173-175; Leipsic a center of influence, 178; Leipsic method, 176; Manual training and German pedagogy, 169; method of teaching, 178; Munich, 184; Strassburg and Berlin, 191; trained teachers, not artisans, 176
- Manual training high school, first in America: course of instruction in St. Louis school, 353, 359; equipment of St. Louis school, 351; Manual Training School of Washington University, 347-359; new type of high school, 347-359; theory of shopwork in St. Louis school, 355; time schedule at St. Louis school, 353
- Manual training in normal schools: Bridgewater, 464; Chicago (Cook County), 465; Millersville, 466; New Britain, 465; Oswego, 464; San Jose, 465; Trenton, 465; Whitewater, 465
- Manual training in public elementary schools: Beardstown, Illinois, 428; Boston, 429; contribution of Ira S. Griffith, 443-447; criticisms of manual training, 439; Dwight School experiment in Boston, 409; early industrial work in Boston, 402; exhibit at Columbian Exposition, 434; Gloucester, girls as well as boys, 407; Jamestown, New York, 421; Leavitt becomes principal of manual-training schools, Boston, 435; modifying influence, 435-445; Montclair, New Jersey, first to vote funds for manual training, 419; New Haven, 423; Omaha, 428; Peru, Illinois, 424; Philadelphia, 427; Springfield, Massachusetts, 428; Trybom's cardboard sloyd, 449; Washington, District of Columbia, 428
- Marble, A. P.: opposed "shops-in-the-basement," 366; ridiculed Walker report, 361
- Mason, John H., 468, 484
- Massachusetts Commission: ap-

- pointed by Governor William L. Douglas, reported in 1906, 513; new commission appointed in 1906, 515; recommendations, 514; recommended independent industrial-school system, 515; reported that 25,000 children were in the industries of Massachusetts, 514
- Mather, Sir William, 232
- Mathewson, Frank E., 386, 502
- McMurry, Oscar L., 504
- Mechanic Arts School, Komotau, Bohemia: 43; course of study, 44
- Merrill, George A., 510
- Mikkelsen, Ansel, opened first educational sloyd school in Denmark, 98
- Mill, John, 276
- Miller, Antoinette, 499
- Miller, Ralph H., 376
- Mitchell, John, 537
- Morris, William, 296
- Morse, Charles H., 515
- Munsell, Albert H., 493
- National Aid to Vocational Education, Commission on, 546
- National Society for the Promotion of Industrial Education: efforts to secure national legislation, 543-549; organization meeting at Cooper Union, 517; preliminary committee work, 517
- New York State Report on apprenticeship and industrial education, 522-527
- North Bennett Street Industrial School, 410
- Noyes, William, 489
- Ordway, John M.: 333, 429, 430; director at Tulane University, 382; stated results of manual training in Europe and America, 364
- Ortner, Evan, 260
- Pabst, Alwin, 179
- Page, Carroll S., 521, 545
- Page, James A., 409
- Park, Joseph C., 476
- Parker, Francis W., 439
- Parsons, Frank, 537
- Part-time cooperative schools, 530
- Pearson, John C., 241
- Pendleton, Charlotte, 427
- Pendleton, E. M., 494
- Perry, Walter S., 493, 498
- Phelps, Clarence L., 482
- Pickwick, Eli, Jr., 381, 449
- Piez, Richard K., 476
- Playfair, Sir Lyon, 278
- Pritchett, Henry S., 517, 543
- Prosser, Charles A.: becomes secretary of National Society for the Promotion of Industrial Education, 546; State director of vocational education in Massachusetts, 517
- Ragged School Movement, 221
- Reynolds, J. H., 260
- Rich, Ednah A., 480
- Richards, Arthur W., 440
- Richards, Charles R.: 442, 467, 489, 517; suggested the term "industrial arts," 453
- Riley, Mrs. M. E., 499
- Rindge, Frederick H., 382
- Robbins, George, 496
- Roberts, William E., 392
- Rodhe, Eva, system of primary sloyd, 92-96
- Rollins, Frank, 385
- Rose, Eben, 493
- Rowell, Frank, 403
- Royal Society of Arts, England, 281
- Runkle, John D.: 320, 494; his conclusion on value of shopwork, 321; his estimate of the Russian system, 321; *The Manual Element in Education*, 340-346
- Ruskin, John, 295
- Russ, R. S., 478
- Russell, W. C., 494
- Russian system of teaching the mechanic arts: 13, 48; analysis of processes, 13; courses of instruction, 19; effective school substitute for apprenticeship, 46; equipment of the shop, 18; exercise pieces, 19-39; general principles, 17; methods of teaching, 22; origin of, 14; some results, 41; three periods, 19-41; the teacher, 46; workbook, 40; class instruction, 40; shown at international expositions, 42; three

- successive periods, 19; workbook, 40
- Salicis, Gustave Adolphe, 110, 123
- Salomon, Otto: advocate of educational sloyd, 64; emphasized importance of trained teachers, 66; far-reaching influence of, 88; Nääs, 62; visited Cygnaeus in Finland, 64
- Sandberg, Josef, 431
- Sargent, Walter, 502
- Sayre, William L., 375
- Schaeffer, N. C., 465
- Schenkendorff, Emil von, 171
- Schwab, Erasmus, 170
- Scott, Jesup W., 376
- Seaver, Edwin P., 434
- Selvidge, Robert W., 502, 504
- Seville, John W., 496
- Shaw, John V., 419
- Shaw, Mrs. Quincy A., 411, 431, 538
- Shopwork instruction in America before 1880: as part of general education, 321; course and equipment at the School of Mechanic Arts, 324; for those who wish to enter industrial pursuits, 322; general method, 319; ideas concerning shopwork in education, 319; Illinois Industrial University, 313; impressions of Russian exhibit in 1876, 320; instruction without trade motive, 318; Kansas State Agricultural College, 313; results at School of Mechanic Arts, 320; should be available to boy, 336; Stevens Institute of Technology, 313; tool exercises devised in 1872, 319; value of mechanic-arts instruction, 335; Worcester County Free Institute, 310
- Shopwork instruction, origin of, at Washington University, 318
- Silke, Lucy S., 501
- Sisson, Edward O., 487
- Sloyd: aims of educational, 67; characteristics of educational sloyd, 64; compulsory in the higher schools of Finland, 60; Danish, 97; Danish Sloyd Association, 98; decline of home sloyd, 102; educational, 63; educational principles, 87; in folk schools of Finland, 56, 61; equipment for Swedish, 68; home, 53; metal, 89; method of teaching, 86; in normal school of Finland, 58; primary, 92; principles of Danish, 99; recognition of individual differences, 100; school at Nääs, 61; Swedish Association, 55; Swedish, early schools, 55; Swedish models, 70-83
- Sloyd Training School, Boston, 470-475
- Smith, George, 334
- Smith, Senator Hoke, 546
- Smith-Hughes Bill signed by President Wilson, 549
- Snedden, David, State commissioner of education in Massachusetts, 517
- Snow, Bonnie E., 500
- State legislation for vocational education, 539
- Stetson, Charles B., 494
- Stout, James H., 484
- Summers, L. L., 477
- Swan, Robert, 402
- Swedish Sloyd in America, 430-432
- Tate, John William, 235
- Teacher: artisan-teacher in Paris, 122; importance of trained, 66; regular classroom, 128; same for handwork as for other subjects, 58; trained teachers of other school subjects, 176; sloyd teacher a school teacher, 64; trained, 176; training at Nääs, 62
- Teacher training in France, 131
- Technical education in England: only apprentices at Regent Street Polytechnic, 288; The Arts and Crafts Movement, 295; Central School of Arts and Crafts, London, 298; The City and Guilds of London Institute, 279; City Guilds Technical College, 281; Finsbury Technical College, 283; great awakening, 276; Junior technical schools, 300; London Parochial Charities Act, 285; London Polytechnic Council, 290; London Polytechnics, 284-290; The National Association for the

- Promotion of Technical and Secondary Education, 293; National Training School of Art, 278; Science and Art Department of the Government, 278; "technical education" defined, 275; trade schools of London, 303; typical English technical school, 290; wealthy Livery Companies, 279
- Textile School, Crefeld, Germany, 205
- Thompson, Charles O., 311, 494
- Thompson, Silvanus P., 222
- Thring, Edward, 228
- Todd, Ambrose, 317
- Tolain report, France, 166, 167
- Tracy, Mary H., 481
- Trade schools, public, full-time, 533
- Trade and technical education in France: comparative study of time allowances in industrial courses in national schools, 152; Corbon commission, 147; evening schools, 164; Municipal Trade Schools of Paris, 153-159; national industrial schools, 149; national schools of trades and industries, 160-163; national policy begun, 146; national system of vocational schools, 151
- Trade and technical education in Germany: Bismarck's purpose, 193; building trades school, 207; cooperation of guilds and continuation schools of Munich, 204; complete substitute for apprenticeship, 204; continuation schools, 194; Imperial Industrial Law, 195; industrial art schools, 210; industrial continuation schools of Munich, 197-204; school of cabinetmaking, 209; subjects of study in industrial continuation schools, 213; textile school, 205; typical weekly program in industrial continuation schools, 201
- Training special teachers of manual training: Bradley Polytechnic Institute, 486-488; course in pedagogy of manual training accepted toward A.M. and Ph.D. degrees, 470; Miami University, 490; Oshkosh Normal School, 477; Oswego Normal School, 476; professional courses at Teachers College, 466, 468, 469; requirements for certificate in Sloyd Training School, 472; Sloyd Training School, Boston, 470-475; State Normal School of Manual Arts and Home Economics, Santa Barbara, California, 479-482; State Normal School of Manual Training, Pittsburg, Kansas, 477; Stout Institute, 484; Stout Institute, professional work outlined, 485; Teachers College becomes a part of Columbia University, 470; Teachers College, New York City, 466-470; Throop Polytechnic Institute, Pasadena, California, 483; University of Chicago, 489; University of Wisconsin, 491
- Trybom, J. H., 449
- United States Chamber of Commerce took referendum vote, 549
- Variations from original type of manual-training high school: Baltimore, 374; Boston, Mechanic Arts High School, 384; Brooklyn, Pratt Institute, 382; Chicago, Lane Technical High School, 386; Chicago, Manual Training School, 373; Cincinnati, 380; Cleveland Technical High School, 386; Detroit, Cass Technical High School, 387; Indianapolis, 383; Jersey City, William L. Dickinson High School, 386; Louisville, 382; Muskegon, Michigan, Hackley Manual Training School, 382; New Orleans, Tulane University, 382; New York City, Stuyvesant High School, 385; Philadelphia, 375; St. Paul, 380; Springfield, Massachusetts, Technical High School, 384; Stout Manual Training School, Menomonie, Wisconsin, 382; Toledo, 376
- Vocation Bureau, Boston, 538
- Vocational education in America before 1906: apprentice schools, 510; California School of Mechanical Arts, 510; Drexel Institute,

- 510; Evening School of Trades, Springfield, Massachusetts, 511; half-time school proposed by Milton P. Higgins, 512; Hebrew Technical Institute, 509; New York Trade School, 507; Pratt Institute, 510; Williamson Free School of Mechanical Trades, 508; Wilmerding School of Industrial Arts, 510
- Vocational guidance, 537
- Waite, George S., 496
- Walker, Francis A: city boy needs manual training, 368; report on industrial education, 360
- Wallburg, Valentine, 324
- Warner, Charles F., 384, 511
- Washburn, Ichabod, 311
- Weitbrecht, George, 381
- Wesson, Walter G., 393, 428
- Whitaker, Channing: 324; planned the first American textbook on school-shop woodworking, 406
- Whitcomb, Fred C., 490
- White, Charles F., 348
- White, E. E: opposes the Walker report, 360; workshop not to teach trades in public schools, 367
- Whitesitt, A. H., 479
- Whittling School, The, Boston, 403
- Williamson, Isaiah V., 508
- Wilson, Woodrow, 549
- Wisconsin law of 1911, 540-542
- Woodward, Calvin M: 317, 494; gives notable address in Boston, 366; his tribute to the Russian system, 322; his vision, 337; his prophesy, 338; pointed to results in the St. Louis school, 361, 362; summarized the ten years of discussion, 372; visits England, 232
- Worcester County Free Institute of Industrial Science, 311
- Worcester Trade School, 534
- Workingman's School, 412
- World's Fair, London (1851), 276
- Wright, Carroll D., 513









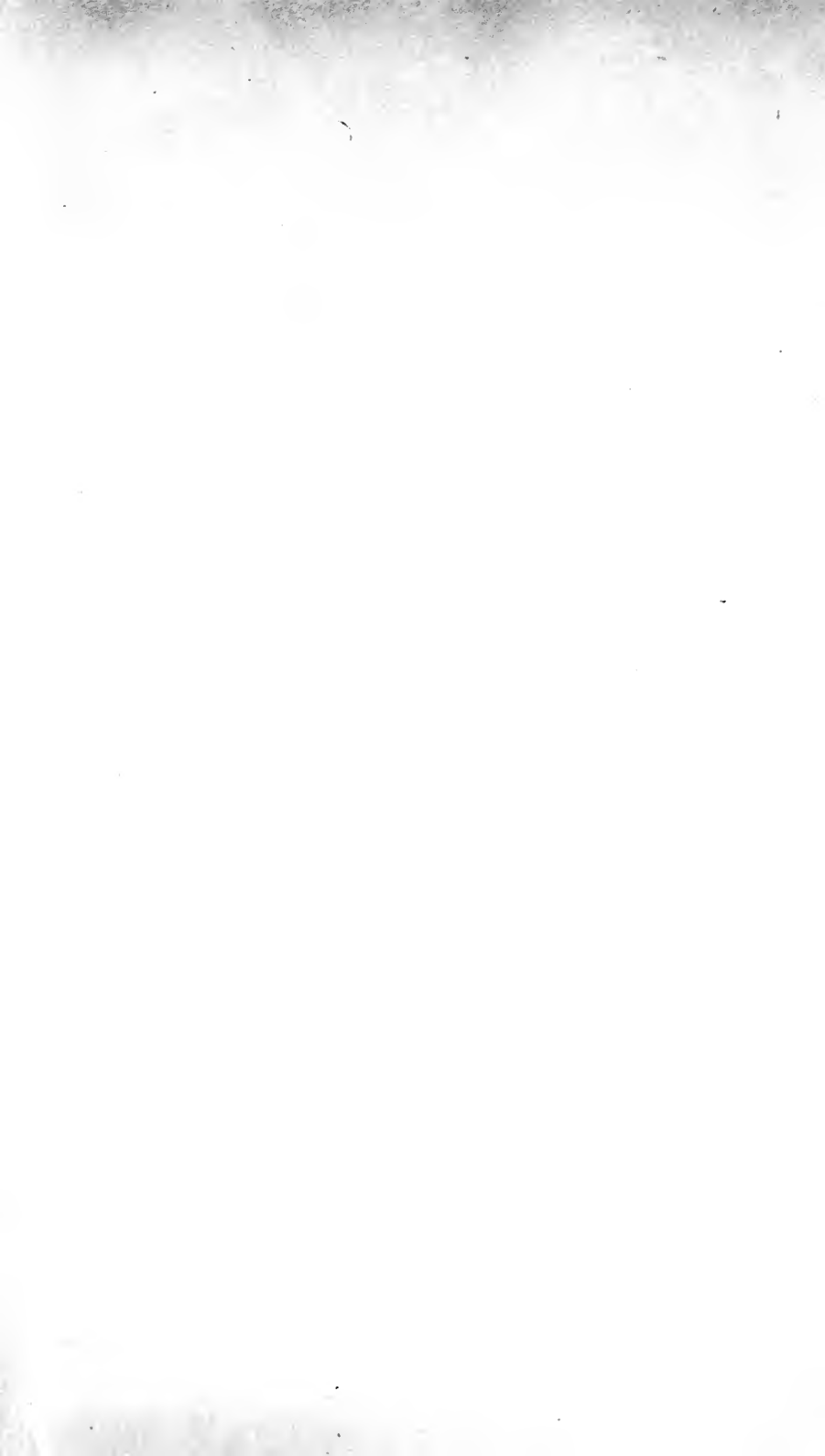

313
567a







