

UC-NRLF

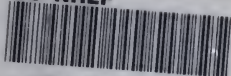

⌘B 32 017

Main

Lib.

Agric. Dept.

LIBRARY

OF THE

UNIVERSITY OF CALIFORNIA.

Received JUL 10 1895 . 189

Accessions No. *60512* . Class No.



THE
ALKALI TRADE

LONDON : PRINTED BY
SPOTTISWOODE AND CO., NEW-STREET SQUARE
AND PARLIAMENT STREET

THE
HISTORY, PRODUCTS, AND PROCESSES
OF THE
ALKALI TRADE

INCLUDING THE MOST RECENT IMPROVEMENTS

BY
CHARLES THOMAS KINGZETT
(CONSULTING CHEMIST)

WITH 23 ILLUSTRATIONS



LONDON
LONGMANS, GREEN, AND CO.
1877

TP201
K5

60512



PREFACE.

IN the following pages I have endeavoured to give a concise but comprehensive account of the largest branch of chemical industry of this country.

Importance has been attached in this attempt, to matters of history, interesting as they are in showing how gradually knowledge is perfected. It will, for instance, be seen that at no time in the history of the Alkali Trade has an inventor brought into use a totally new process; so-called new processes are but the perfected forms of old ones, and are based upon previously known facts. Moreover, the greatest commercial successes have been achieved, not by the practical application of new ideas, but in the development of old ones. Taken as a whole, this trade well exemplifies the truth that scientific investigations necessarily precede industry.

Men, from time to time, discover new facts, either by following out a process of induction constructed upon a knowledge of the relations existing between previously known facts, or by accident. Accidental discoveries are somewhat inevitable in experimental science, where the method of enquiry depends upon reasoning, for the correctness of which there is no absolute test. But for

science and humanity it is all one, no matter what be the instrument of discovery, so long as discoveries are effected. For in their time, other men arise, and in the course of their studies find the explanation, where before there was only known the fact, and with such advances there sometimes ensues a generalisation, a law, or a new method of enquiry. Simultaneously, progress in industrial applications is made.

In discussing, therefore, the value of abstract scientific work, those who engage in such discussion must be further prepared to discuss the good for humanity of all progress, not only in industry and commerce, but in every direction of civilisation. Such questions, in fact, lead only to the doctrine of evolution and the idea of eternity, and while first and final causes are alike hidden from us, we cannot withstand the march of progress.

With this idea before my mind, I have not hesitated, therefore, to bestow considerable attention in this work, to propositions and suggestions for improved processes, which have not as yet, and perhaps never may be, adopted in practice.

The processes which are actually in use have been so described, that while scientific accuracy has in no case been sacrificed, many technicalities have been avoided, in order that the accounts should be readable alike to the outside public, and to those engaged practically in the trade. To the latter class of readers, it is hoped that the book will be useful as a record of the state of the trade, and as a suggestive work of reference.

In order to make the book as complete in itself as possible, beyond the history and descriptive accounts of the various processes, I have given attention to the uses of the products in other arts and manufactures. Particular stress has also been laid upon waste products and their possible utilisation, while the statistics in reference to the trade will be found to accurately indicate its extent.

In parting with the book from my hands, I cannot forget the valuable help I have received from my friend Mr. George Chaloner, who, as editor of 'Iron,' bestowed especial care and aid during the publication of the following chapters in that Journal.

My thanks are also due to Mr. Richard Cail and Mr. Edmund K. Muspratt, the hon. secretaries of the Soda Association, for having furnished me with some valuable statistics.

To the other following gentlemen I desire to express my gratitude, in some instances for drawings of plant, and in others for useful information: Messrs. William and John Glover, Mr. Walter Weldon, Dr. Sprengel, Mr. James Mactear, Mr. W. Henderson, Mr. G. E. Davis, Mr. Claudet, Mr. J. Cammack, and Messrs. Daglish & Co. of St. Helens.

In conclusion, I trust these gentlemen will find justification for their kindness, in the work I now leave in the hands of the public.

CHARLES T. KINGZETT.

ANALYTICAL AND CONSULTING LABORATORY,
1 VICTORIA STREET, WESTMINSTER, S.W.



CONTENTS.



CHAPTER I.

INTRODUCTION.

	PAGE
Considerations regarding industry in its bearing on the wealth of nations—Historical notes on English chemical industry—Progress of pure chemical science—Patent laws and Governmental recognition of science—Scheme of the English alkali trade—Remarks on manufacturers and the conduct of works—Contrast of the trade in England and Germany	1

CHAPTER II.

PYRITES, SULPHUR, AND NITRE, AND THE HISTORY OF THE MANUFACTURE OF SULPHURIC ACID TO 1840.

Natural deposits of sulphur and their origin—Attempts to utilise the sulphur in gypsum—The use of pyrites, and their occurrence in nature—Statistics regarding pyrites—Attempts to make artificial pyrites—Natural beds of soda nitre; statistics—History of sulphuric acid to 1840—Manufacture of sulphuric anhydride	11
--	----

CHAPTER III.

MANUFACTURE OF SULPHURIC ACID.

Pyrites burners (different forms)—Nitric pots—Dr. Sprengel's water spray apparatus—Sulphuric acid chambers—Gay-Lussac's absorbing columns—Glover's towers—The concentration of sulphuric acid; old and new methods—Statistics of the trade—Purification of commercial acid—Notes on the trade in the South of France—Other processes for making sulphuric acid	26
--	----

CHAPTER IV.

THE TREATMENT OF BURNT PYRITES ; EXTRACTION OF COPPER,
SILVER, AND GOLD ; THE MANUFACTURE OF SULPHATE
OF COPPER.

Composition of burnt pyrites—The Henderson wet process of copper extraction—Removal of arsenic from copper liquors—Utilisation of the sulphate of sodium in copper liquors—Augustin's process for extracting silver from its ores—Claudet's process for extracting silver and gold from copper liquors—Chadwick and Jardine's improvements on Henderson's process—Mr. Gibb's process for extracting the silver—Dr. Hoffmann's improvements in the German trade—Manufacture of sulphate of copper 4

CHAPTER V.

HISTORICAL SKETCH OF ALKALI MANUFACTURE.

Ancient literature—Natural soda deposits—The old trade in kelp and barilla—Introduction of Leblanc's process and its history—Statistics of the soda trade 68

CHAPTER VI.

MANUFACTURE OF SALT, SULPHATE OF SODIUM, AND
HYDROCHLORIC ACID.

The uses and manufacture of salt—Statistics relative to salt decomposed for soda-making—Salt-cake furnaces—Cammack and Walker's and other improved forms of furnaces—Jones and Walsh's improvements—Longmaid's process—Historical notes leading up to Hargreaves' process—Description of Hargreaves' process—Other processes for making sodic sulphate—Manufacture of Glauber's salts . . . 76

CHAPTER VII.

MANUFACTURE OF CARBONATE AND BICARBONATE OF SODIUM.

Analyses of salt-cake, limestone, ashes of slack, etc.—Description of hand-worked black ash furnaces—Analyses of black ash—Revolving furnaces—Mr. Mactear's improvements in the manufacture of carbo-

	PAGE
nate of soda—Losses of soda in the various processes—Lixiviation of black ash or crude soda—Action of water upon ball soda—Composition of vat liquors—Production of soda ash, white alkali, soda crystals, etc.—Bicarbonate of sodium—Statistics	99

CHAPTER VIII.

MANUFACTURE OF CAUSTIC SODA.

Historical Notes—The causticising operation—Composition and uses of the lime-mud after causticising—Concentration of the caustic lyes—Oxidation of the 'pots'—Salting down process—Composition of 60 and 70 per cent. caustic soda—'Bottom' caustic—Red liquor and cream soda	118
---	-----

CHAPTER IX.

ALKALI WASTE; REGENERATION OF THE SULPHUR; MANUFACTURE OF HYPOSULPHITE OF SODIUM.

Alkali waste: its composition, etc.—Various suggested processes for effecting its utilisation, including those of Gossage, Duclou, Weldon, etc.—Mond's process for regeneration of the sulphur—Mactear's process for sulphur recovery—Schaffner's refining apparatus—Recovery of the sulphur by means of alloxan—Manufacture of fictitious pyrites from alkali waste and burnt pyrites—Manufacture of sodic hyposulphite	133
--	-----

CHAPTER X.

SODA PROCESSES OTHER THAN LEBLANC'S; INCLUDING THE 'AMMONIA PROCESS.'

Processes of Hunt, Gossage, Arrot, Ward, etc.—Manufacture of soda from cryolite—Tilghmann's and Fritzsche's processes—Other processes—Lunge's baryta process—Improved form of Bachet's process—History and description of the ammonia process—Davis's new phosphate of sodium process—Manufacture of sodic phosphate	149
--	-----

CHAPTER XI.

MANUFACTURE OF SOAP.

Historical notes regarding soap and its uses—The chemistry of soaps—Fats and fixed oils—Hard, soft, and silicated soaps—Resin soap—Soap from the yolks of eggs—Mottled soaps—Statistics	169
---	-----

CHAPTER XII.

HISTORICAL NOTES ON THE BLEACHING INDUSTRY.

PAGE

Ancient records of the art of bleaching—State of this industry at the end of last century—Improvements introduced by Roebuck and Horne—Influence of the discovery of chlorine—Rationale of bleaching by chlorine—Lye of Javelle, or potassic hypochlorite—Bleach liquor, or calcic hypochlorite—Bleaching powder—Process of bleaching by means of chloride of lime—The constitution of bleaching powder—Suggestions for improvements in the bleaching powder trade	178
--	-----

CHAPTER XIII.

THE OLD PROCESS OF MANUFACTURING CHLORINE.

Various uses of hydrochloric acid—Manganese ores and their sources—Early methods of generating chlorine—Chlorine stills—The process of making chlorine prior to introduction of Weldon's process—Elliott's and Dunlop's methods for regeneration of the manganese—M. Lauren's method of making chlorine—Shank's and Dunlop's chlorine processes—Longmaid's and Hargreaves' processes—Other processes which have been proposed	184
---	-----

CHAPTER XIV.

WELDON'S CHLORINE PROCESS (*a*).

Statistical notes of the bleaching-powder trade—Description of the Weldon plant and process—Chemistry of the process—Valentin's improvement in the oxidation of the manganese—Consideration of various so-called continuous reactions	196
---	-----

CHAPTER XV.

WELDON'S MAGNESIA CHLORINE PROCESS (*b*).

Impetus given to chemical industry by the introduction of Weldon's original process—The defects of the last-named process—Description of the new process for obviating these defects—Utilisation of dilute chlorine	207
---	-----

CHAPTER XVI.

DEACON'S AND OTHER CHLORINE PROCESSES.

	PAGE
Description of the Deacon process—Various improvements effected from time to time—The difficulties of the process—Hargreaves' and Robinson's chromate process	216

CHAPTER XVII.

MANUFACTURE OF BLEACHING POWDER, BLEACHING LIQUOR,
CHLORATE OF POTASSIUM, AND EPSOM SALTS.

Purification of the chlorine gas—Preparation of the lime—Description of the various chambers and the process—Analyses of good and bad bleaching powder—Working results and statistics—Notes on the French trade—Manufacture of bleach liquor—Manufacture of chlorate of potassium—Improvements in this last manufacture—Preparation of Epsom salts	224
--	-----

CHAPTER XVIII.

GENERAL CONSIDERATIONS REGARDING THE ALKALI TRADE ;
CHEMICAL CLIMATOLOGY, ETC.

The direct objects of manufacturers—The Alkali Act of 1863—The Amendment of 1874—Improvements introduced by the use of Gay-Lussac's and Glover's towers—Recovery of manganese from still-liquors, and sulphur from alkali waste—Nuisance from coal-smoke—General remarks	234
--	-----

CHAPTER XIX.

STATISTICS OF THE ALKALI TRADE.

Fluctuations in prices and profits—Past and present value of articles—Returns of 1861—Returns of 1866—Returns of 1867 (Tyne district)—Statistics relating to 1874—The chemical industry of Glasgow and the Clyde Valley—Table showing production upon 100 tons pyrites	242
--	-----



LIST OF ILLUSTRATIONS.



FIGURE	PAGE
1-3. SHOWING CONSTRUCTION OF PYRITES BURNERS	29, 30
4, 5. AN ARRANGEMENT OF TWENTY SETS OF BURNERS, WITH NITRE POTS, AND GAS CONDUCTING PIPES	30, 31
6. 'NITRE POT' COMMONLY EMPLOYED	33
7. SPRENGEL'S 'WATER SPRAY' APPARATUS	37
8, 9. GLOVER'S DENITRATING TOWERS	44
10-12. PLAN AND ELEVATION OF DECOMPOSING POT AND ROASTER FOR MAKING 'SALT CAKE'	83, 84
13, 14. PLANT USED IN HARGREAVES' PROCESS FOR MAKING 'SALT CAKE'	<i>to face</i> 92, 93
15, 16. ENGRAVINGS OF REVOLVING 'BLACK ASH' FUR- NACE	<i>to face</i> 105
17. ENGRAVING OF REVOLVING 'BLACK ASH' FUR- NACE	105
18, 19. CAUSTIC SODA 'POTS'	126
20. APPARATUS FOR MELTING SULPHUR BY MEANS OF STEAM	144
21, 22. PLANT USED IN WELDON'S PROCESS OF CHLORINE MANUFACTURE	199, 200
23. WELDON'S MANGANESE REGENERATION PLANT (PLAN) <i>to face</i> 200	



HISTORY, PRODUCTS, AND PROCESSES
OF
THE ALKALI TRADE.

CHAPTER I.

INTRODUCTION.

THE WEALTH of a nation may be said to be indicated by the magnitude of its commerce. This must have been so from the earliest times, although the several factors upon which all commerce is based, must individually and relatively have possessed very different values to those now attached to them. These factors are natural products, agricultural products, and manufactured products.

Could we go back sufficiently far in the history of nations, we should come to a time when commerce meant literally the exchange and barter of the commonest natural products; but as the peoples progressed in civilisation so must their requirements also have increased, and to meet these requirements it became necessary to apply to natural products certain processes based on a study of natural laws, in order to shape those articles to the desired uses. But so small must have been the extent of such modifications of natural products as scarcely to merit the name

manufactures, while they, beyond doubt, represent the first germs of that which has become the most important factor in the commerce of nations. While in such times it was possible for much to be accomplished through agriculture, yet even in this direction the improvements had to keep step with the march of time, until now agricultural products may be said to be not only the increase of the earth, but the increase of the earth as controlled and guided by the intervention by man, of scientific applications.

Passing on to consider more in detail the history of manufactures, we will confine ourselves more especially to those which have chiefly developed through chemical knowledge being brought to bear upon them ; and it will not be without interest to take a brief retrospect of the rise and progress in this country of that important branch of manufacture, known as the Alkali Trade, before pausing to study in detail its various ramifications.

The study of manufactures during the Middle Ages is attended with the greatest interest, for by it we are enabled to perceive how industry and science go hand in hand. Improvements in manufacturing industries can only arise through the application of new knowledge, which latter can only be attained through the method of experiment. Of such a method the ancients were in want ; hence, we find, in very early times, when the alchemists evaporated common water, and obtained a residue, that residue was regarded as a product of transformation of the water, a perfectly legitimate conclusion, when we consider that they had no knowledge of the power of certain liquids to dissolve certain substances.

Looking back over the pages of English history, we

find that in the fifteenth century our chief exports were wool, sheepskins, and leather, while our imports were wines, silks, spices, and precious metals. There was also a considerable iron trade carried on in Sussex, which continued to prosper for several centuries.

In the seventeenth century English commerce suffered vastly from the system of monopolies, which was not abolished till the time of the Long Parliament, but even at that early date, Manchester was famed for its cotton manufactures, while our silk and cloth industries were greatly improved by the French Protestants who, after the Revocation of the Edict of Nantes, found in England a refuge and a home (1685). About the same date, banking and the modern system of the post-office originated. Nearly a century later, spinning machines were invented (1769); in the same year Watt patented the steam-engine; and in 1785 the power-loom was introduced; moreover, the country was intersected by canals, which greatly benefited the inland trade.

These discoveries and improvements constituting the essentials of progress in industries, were only contemporaneous with scientific discoveries. While Watt was studying the steam-engine, the chemists in their laboratories were not idle. Chemistry was already far removed from its birth, and instead of alchemical experiments and wild speculations on the transformation of metals and the 'philosopher's stone,' there was substituted the discovery of natural laws by experiments based upon reasonable hypotheses. Lavoisier and Priestley had determined the true nature of oxygen, and the balance had been introduced into chemical science. Scheele had in 1774, discovered chlorine and its bleaching characters, and

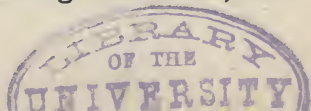

Chemistry itself may be said to have been no longer a dark search after things removed from the mental grasp, but henceforth a science whose function was *the study of the laws of changes of matter*. It was henceforth required that the amounts of the products of the changes should be determined, and their relations to the original matter established; it was not enough to know that oxide of mercury evolved oxygen on heating, but it was requisite to ascertain how much oxygen a given quantity of oxide of mercury *could* evolve.

But we must not dwell on this fascinating subject; we must pass on to consider Chemistry as a science built on a framework which had been raised by the labours of such men as Black, Lavoisier, Berzelius, Scheele, and Priestley; we must pass on to consider the applications of derived knowledge to the arts and manufactures. And having done so, we appreciate as the natural consequences the blessings of cheap soda and soap, 'cheap light and cheap cleanliness.' Neither can we stay to dwell on the strides made in chemical science in more recent times; but we shall be enabled to appreciate the importance of such progress when we proceed in future chapters to study the industries to which the gained knowledge has been applied. Suffice it here to say, that Mr. Gossage has shown that certain chemical industries have so developed, that now by the consumption of a manufactured article, namely soap, the civilisation of a country may be estimated. Unfortunately it is not so pleasant to contemplate the lives of those men who by their life-work have furnished such a happy state of things. It may be said of most of them that it was their fate to die 'unwept, unhonoured, and unsung'; and especially of one is this true, and one of the most

deserving of men, for he it was who, at the moment of peril to his country, opened to her, resources of wealth inestimable—resources hitherto unknown. It was Le Blanc; he who, after a life of poverty and hardship, lived for many years in a foreign hospital, and finally perished by what has proved the right arm of the alkali trade—his own.

England is open to similar charges of neglect of its best sons, and even now, in these days of boasted civilisation, no fact is more striking than that science is not sufficiently recognised by the Government of this country. It is and must be admitted on all sides that scientific research necessarily precedes the application of science to industry, and yet, even now, the pay of the chemist is little or no better than the recompense of an unskilled labourer. True it is that the patent laws afford some protection to those who are in the position to patent, but many even of our best chemists are not possessed of the means, while for the most part chemical inventions and discoveries do not admit of protection in this way. We cannot imagine, for instance, Scheele patenting the mode of preparation and uses of chlorine, and yet his discovery has led to an industry, viz., the manufacture of bleaching powder, of which substance this country alone produces annually more than 100,000 tons.

We can only hope that the time is near at hand when we shall have a Government sufficiently enlightened to appreciate that it is to its best interests to foster and encourage science in all its multiplicities, for by so doing alone, can England maintain that supremacy over all other nations which it now possesses in its varied industries.

With these preliminary observations we will now return to our more immediate subject. The alkali trade

as now worked in Great Britain is planned out on the adjoining scheme, and in the following chapters it will be our endeavour to give a complete sketch of the history, products, and processes involved in each branch, together with some remarks on the uses of the manufactured products. In doing this we shall pay especial attention to those recent improvements which may be said to have almost revolutionised the whole trade, by effecting the utilisation of what were previously waste products, or by their avoidance. While, therefore, the work will stand alone as the only one of its kind, it is hoped that it will serve as a basis for further thought and research by chemists, who, as a body, may be safely said to be unacquainted with those chemical processes which form the foundation stones of the alkali trade; and if, in assisting to destroy and overthrow the use of imperfect empiric, or 'rule-of-thumb' methods often largely employed in alkali works, it indicates a more scientific method, it will accomplish some good.

Products of the Trade:—Iron, copper, silver, gold, sulphuric and hydrochloric acids, bleaching powder, potassic chlorate, calcic chloride, sulphate of soda, caustic soda, sodic carbonate and bicarbonate, sulphur, sulphate of copper, hyposulphite of sodium, phosphate of sodium, and Epsom salts.

Waste Products:—Part of the hydrochloric acid as chloride of calcium, all the lime or nearly so, part of the sulphur.

Regenerated Products:—Nitre (partly), manganese and part of the sulphur.

The introduction of recent improvements in the alkali trade was attended with much opposition from manufacturers themselves.

Scheme of the Alkali Trade as now worked.

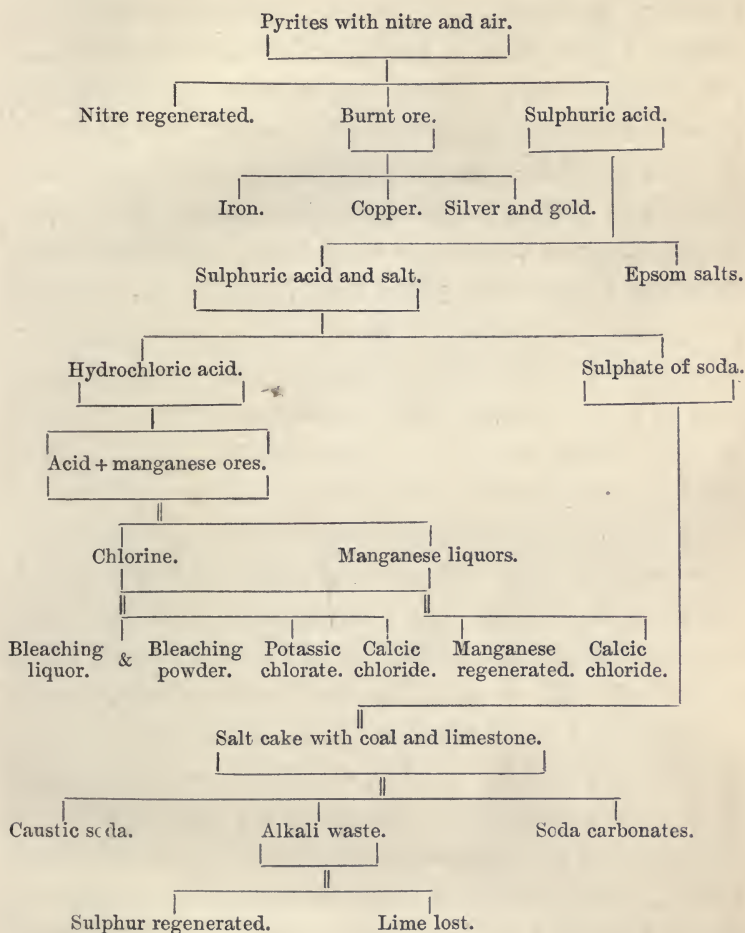

However strange at first sight it may seem, that manufacturers should so stand in their own light, it is not so inexplicable if we bear in mind that they were unscientific, and, moreover, it must be admitted that there is good reason why they should be chary of adopting new processes until the strongest evidence is forthcoming

that the new processes give better results than the old ones; for while, however good the improvements may be, there is always the greater possibility at such times than at others, that the improvements should themselves be improved upon; and every change of plant means, for the time at least, the sacrifice of so much capital.

It is gratifying, however, to find that many manufacturers are now well-known scientific men; to the truth of this assertion the names of Deacon, Pattinson, Young, Scheurer Kestner and others testify most fully. But it is to be deplored, perhaps, that so much scientific ignorance should exist as is known to exist among many managers and the second-rate chemists often employed at alkali works. These men often boast loudly of their rule-of-thumb methods of working, when those methods are known to be unreliable and therefore worse than useless, inasmuch as they mislead. Of course, when a process becomes familiar to those working it, it is often possible to adopt methods of testing certain products in an abbreviated way, and so save time and trouble, but there can be no doubt that many of these methods at present largely used are *not* reliable, and their use should therefore be discontinued. We refer, for instance, to the estimation of nitrous compounds in oil of vitriol by simple dilution with water; the determination of the temperature of vat liquor by the hand alone, etc. In short, when it is recognised that the chemist's duty in an alkali works consists in the examination and analysis of materials consumed, and products manufactured, and so forth, it becomes evident that his chemical ability should be such as to enable him to accomplish these things in a reliable manner; and also sufficient to enable him to trace any

loss in a manufacturing process to its source, or to detect any tampering of the materials by the workmen.

Thus, suppose the production of 'caustic' in a soda works to be below the average, then by the analysis of the successive intermediate products, as the salt cake produced in the pots, the vat liquors and so on, he should be able, generally, to discover the source of the loss. In the case under consideration, this might arise from the employment of 'salt cake' (sodic sulphate) below average strength, or from the 'balls' (crude sodic carbonate) being 'burned' or 'green,' or from imperfect washing of the lime mud from the causticiser, etc.

To any one acquainted with the status of chemical science in alkali works, the foregoing remarks will not be matter for surprise. Thus, quite recently, the author of a paper on caustic soda, alluded to laboratory work as a 'kind of out-at-elbows trade' and actually stated his opinion that 'a manager can be too much of a chemist.' To this we must strongly object, for it is absurd to suppose that because a manager may be likewise a good chemist, he will be misguided by his knowledge in attempting more than reasonable 'maximum productions'; on the other hand, his chemical knowledge will serve him as a rudder serves a boat, namely, as a guide by which to obtain a certain result, without loss of time or labour.

Chemical industry is just emerging from ignorance and prejudice, and any attempt to return to that state should therefore be opposed. For, as Parkes tells us in his 'Chemical Essays,' it is not so many years ago 'that Mr. Steer, a very large *aqua fortis* maker at Birstall, near Leeds, was for long accustomed to lay his glass retorts in a shallow rivulet which ran through his fields, where, in a

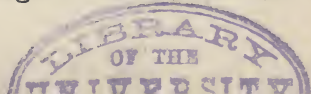

few weeks, the indurated salt was dissolved and washed away in the water.' In short, industrial chemistry has yet much to attain, as is shown by its history, by the existence of the Alkali Acts, and by the mountains of alkali waste that stagnate the atmosphere for miles round the districts where alkali works exist. But, at the same time, these things demonstrate to us what chemical science, aided by engineering, has done for the alkali trade of Great Britain. We cannot do better than conclude this chapter with some observations due to Dr. Lunge, who, in a recent address to the Tyne Chemical Society, stated that one of the largest works in Germany employs six chemists, at from 300*l.* to 400*l.* per annum, and in addition retains the services of a chemist of reputation, *exclusively for theoretical work in the laboratory*, at a salary of nearly 2,000*l.* per annum. This wise conduct gives rise to happy results, as is exemplified (to those who are conversant with the development of the soda trade in Germany) by the following figures:—

From 1867 to 1872, the German production of sulphuric acid increased from 57,825 tons to 84,264 tons; sulphate of sodium from 35,767 to 51,618 tons; and calcined soda ash from 26,250 to 36,227 tons.

CHAPTER II.

PYRITES, SULPHUR AND NITRE, AND THE HISTORY OF THE
MANUFACTURE OF SULPHURIC ACID TO 1840.

BEFORE proceeding to sketch the process employed in the manufacture of sulphuric acid, it will be well if we learn something about the materials consumed, viz., the pyrites or sulphur, and soda nitre. Although, as will be presently seen, the use of (Sicilian) sulphur for making sulphuric acid, has been abandoned, yet, as in the future it may again be used for that purpose, and as in past years it alone was used, it will be of some interest to first describe it.

Sulphur occurs in volcanic districts, as Toscana and Naples, in great abundance; and it has been suggested that much of it has been formed as met with, by the reaction that is known to take place between sulphurous anhydride and hydrosulphuric acid.

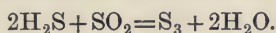

These gases escape through the fumaroles, and by their mutual reaction give rise to sulphur. This supposition derives some support from the fact that alkali waste, after exposure some time to atmospheric influences, often contains free sulphur, doubtless derived by a similar decomposition, arising from the action of acids upon sulphides and hyposulphites of calcium. Most of the sulphur originally consumed in the sulphuric acid manufacture

came from Sicily, no less than 1,164,099 cwt. being imported in 1859, as against 333,731 cwt. imported in 1842 (Richardson and Watts). Sulphur works, however, existed at Walker-on-Tyne, from 1800 to 1822, about twenty tons of roll and flour sulphur being made annually.

The following figures, showing the sulphur exported from Sicily in the years 1853 to 1860, are taken from the 'Report by the Juries of the Exhibition of 1862 : '—In 1853 there were exported from Sicily 97,268 tons ; in 1854, 111,993 ; in 1855, 101,393 ; in 1856, 121,550 ; in 1857, 125,987 ; in 1858, 163,629 ; in 1859, 152,487 ; in 1860, there were exported 137,745 tons.

It will be observed that the exportation has not fallen off, as might have been expected, when it was no longer used for making acid, but this is explained by an increased demand for gunpowder, and in the other various applications of sulphur.

Vast sulphur deposits occur also in Iceland, and in a recently published paper, Professor Gesner states, that in the Island of Saba occur the largest, and certainly the richest and most accessible deposits of sulphur in the world. These masses of gypsum, bearing sulphur, contain as much as 60 per cent. sulphur, as is seen in the analyses furnished by Mr. G. G. Blackwell. Sulphur, 75·81 to 80·57 per cent. ; silicate and sulphate of lime, 14·90 to 20·56 per cent. ; water, 3·63 to 4·53 per cent.

Sulphur is extracted from the mineral matters with which it is associated by fusion and distillation. When Sicilian sulphur was no longer available through the increased price placed on it, which was the effect of a grant of monopoly by the King of Sicily (of which we shall speak further hereafter), manufacturers had to seek other

sources. And so great was the industry in this direction, that Liebig in his 'Letters' tells us, that during the existence of the monopoly of sulphur, no less than 150 patents were taken out for the production of sulphur or sulphuric acid from gypsum.

One of these attempts consisted in exposing gypsum to a high temperature in the presence of silica, by which operation silicate of calcium is formed and sulphurous acid and oxygen evolved. Thus—

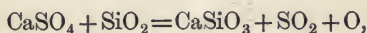

but this reaction takes place but to a limited extent, even at the highest temperatures. Another process which was suggested, consisted in the decomposition of gypsum by hydrochloric acid, giving chloride of calcium, water, sulphurous acid, and oxygen. Thus—

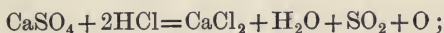

but this process was likewise attended by insurmountable difficulties, and of course in these days one could not for a moment entertain the idea of using hydrochloric acid (in such a manner as to afford no way of recovery), for making sulphuric acid. More reasonable were the proposals and attempts to reduce gypsum by coal to sulphide. Thus—

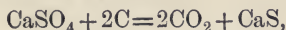

and to decompose the sulphide of calcium into carbonate and hydrosulphuric acid, by means of carbonic acid and steam. Thus—

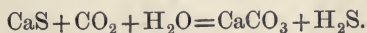

The H_2S to be then burnt into sulphurous acid ready for use in the chamber. This process was devised by Mr. Gossage, but in practice it did not work well.

Without pausing to consider more failures (for they were various and many), we will pass on at once to consider the use of pyrites, which were destined to fill the place which had been occupied by sulphur.

Long before this time, pyrites had been used as a source of sulphur in Germany, and in Nordhausen for centuries, in making the famous fuming acid of that name, by a process of dry distillation. MM. Perret and Son, of Chessy, were the first to successfully use pyrites for the manufacture of sulphuric acid (1833); but it was not till five years later, viz., at the date of the grant of the sulphur-monopoly by the King of Sicily, that its use was introduced into Great Britain on a large scale. At first, our supply was furnished from our own mines in Cornwall and Ireland, but the demand soon spread to foreign countries, especially when processes were devised for extracting the copper and rare metals from the burnt ores. For, previous to that time, ores free from copper only were employed. So great now is the importation of pyrites that 9-10ths of the sulphuric acid made in England in 1874 were obtained from imported pyrites (Dr. Lunge). These were chiefly derived from Spain, Portugal and Norway.

The table given at the head of the following page, showing the percentages of sulphur in various ores, has been compiled from a table in Richardson and Watts' 'Technology' (vol. i., part iii.), and from analyses furnished by the authors of various papers, read before the Newcastle-on-Tyne Chemical Society, etc.

As a general statement relative to pyrites, it may be said that those now in use contain from 1 to 3 and 4 per cent. copper, and from 0·0 to 2 per cent. of arsenic. The pre-

Constituents	First Norwegian	Second Norwegian	Mason's	Belgian	Tuscan	Westphalia	Spanish	Cornish	Irish
Sulphur	46.15	38.17	47.80	45.60	48.4	—	45.2	24.01 and 34.88	34.67 and 42.12
Iron .	42.20	32.80	42.88	38.52					
Copper .	1.20	1.10	2.26	—					
Zinc .	2.10	2.32	0.10	6.00					
Arsenic	—	trace	0.28	trace	0.943 (H.A.Smith)	1.878 (H.A.Smith)			
CaCO ₃ .	2.55	11.90	0.18	0.11					
CaSO ₄ .	trace	—	—	—					
MgCO ₃ .	—	1.08	—	—					
Insoluble	3.20	12.20	2.94	9.00					
Moisture	0.40	0.25	0.95	0.36					
Total .	99.80	99.82	99.39	99.59					

Most suitable ores (J. McCulloch). (Clapham.)

sence of much calcic carbonate militates against the perfect burning of the sulphur, by the formation of sulphate of calcium. The arsenic which is often found in commercial sulphuric acid is derived from the pyrites used. As illustrative of this, and of the fact that this arsenic present in pyrites often finds its way into other products of the alkali trade, we adjoin the following table taken from a paper by Mr. H. A. Smith, read before the Manchester Literary and Philosophical Society.

Substance	No. of Analyses	Per cent. as found
Pyrites before burning (hard Norwegian) .	8	1.649
„ after „	4	0.465
Sulphuric acid	15	1.051
Deposit in flue from kiln	4	46.360
Deposit on bottom of chamber	5	1.857
Hydrochloric acid	8	0.691
Sulphate of soda	15	0.029
Soda waste	6	0.422
Carbonate of soda	12	—
Recovered sulphur (by Mond's process before purification was introduced)	4	0.700
Mond's sulphur, latest methods	2	—

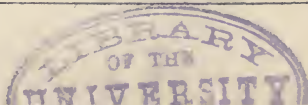

The presence of arsenic in sulphuric acid is likely to lead to much evil, when that acid is used for tinning iron, inasmuch as it is deposited in specific places which then refuse to take the tin. Moreover, from the residual ore, after burning, it finds its way into the copper, which is obtained therefrom in the manner to be shown, and this renders the copper brittle and greatly reduces its market value. We shall, therefore, have to discuss presently various proposals and methods for isolating this arsenic at certain stages.

Mr. R. Calvert Clapham, in a paper from which we shall again quote, gives the total consumption of pyrites of all kinds in the United Kingdom for 1869 as 400,000 tons.

	Tons.
From Norway	63,091
„ Holland	13,983
„ Portugal	140,805
„ Spain	99,648
„ Other parts	2,420
Total	<u>319,947</u>
Produced in Ireland	56,291
Cornwall and elsewhere	19,658
Total	<u>75,949</u>

Of this quantity 265,453 tons were cupreous pyrites.

	Tons.
From Norway	25,000
„ Portugal	140,805
„ Spain	99,648

According to M. F. Kuhlmann (jun.), mines of pyrites were discovered in the island of Kauno, off Norway, in 1865, by M. Defrance. This consists of sulphide of iron and sulphide of copper, furrowed with blende. The average proportion of sulphur contained, is 45 per cent., with 3 per cent. copper; though certain parts contain

from 12 to 14 per cent. copper. It is entirely free from arsenic, which enhances its value, while it contains but very small quantities of silver and gold.

Pyrites are also found in Italy containing a notable proportion of Rammelsbergite (NiAs). In some sorts of Italian pyrites there is as much as 3.75 per cent. nickel, and possibly this may at some future time be as profitably extracted, as the copper is now from Spanish pyrites.

Recently Martin, of Asnières, has proposed to replace pyrites by an artificial sulphide of iron, to be made by fluxing sulphate of lime, ferric oxide and charcoal, in the following proportions:—Sulphate of lime, 1,700; peroxide of iron, 1,000; charcoal, 500.

Another source of sulphur is the sulphurised ferric oxide obtained by Hill's process for abstracting the sulphuretted hydrogen from coal-gas, and otherwise purifying it. This process consists in passing the gas over a mixture of hydrated ferric oxide and sawdust. There is thus obtained protosulphide of iron and free sulphur. By atmospheric oxidation the iron peroxide is regenerated or revived, and the remaining sulphur liberated from its combination, when the product is again ready to purify more gas. These operations are repeated over and over again, until the product contains as much as 40 per cent. sulphur, and 1 ton of the mixture is stated to yield $1\frac{1}{4}$ ton of hydrated sulphuric acid. For burning it, however, a special form of kiln is requisite.

Such a product as that just described is also obtained in the working of a process (to be explained in a future place) for making soda, and unless it proved more desirable to extract the sulphur in the pure state, by dissolving the ferric oxide in hydrochloric acid, it might pro-

bably be well applied for the manufacture of sulphuric acid. It will be understood that the process to which we here refer is not actually in use, although it holds out some promise of success.

The consumption of pyrites in France has risen during the last ten years from an annual amount of 90,000 tons to 180,000 tons, and in England during the same period, from 180,000 to 520,000 tons. It is calculated that the total amount of pyrites in France is equal to a century's consumption. The pyrites from the St. Bel district contain from 46 to 53 per cent. of sulphur.

Soda nitre (nitrate of sodium) occurs in almost unlimited quantity in South America, especially in the district of Atacame, in Peru, where it is found from 0·6 to 1·0 mètre below the surface of the soil. It is used in preference to potassic nitrate, because it is not only cheaper but yields 9 per cent. more nitric acid. The chief quantities consumed in the alkali trade are in the manufacture of sulphuric acid, and for the oxidation of sulphides, etc., in the caustic pots, of which more anon. The commercial name for sodic nitrate is *caliche*.

The following analyses are by Dr. A. T. Machattie, F.C.S.:—

Analyses of caliche	No. 1. White caliche	No. 2. Brown caliche
Sodium nitrate	70·62	60·97
Sodium iodate	1·90	0·73
Sodium chloride	22·39	16·85
Sodium sulphate	1·80	4·56
Calcium sulphate	0·87	1·31
Magnesium sulphate	0·51	5·88
Insoluble matter	0·92	4·06
Water	0·99	5·64
	100·00	100·00

From the commercial caliche the purer soda nitre is obtained by crushing the mineral and recrystallising it from water, whereby a product results containing from 95 to 96 per cent. of pure sodium nitrate. The mother liquors are worked for iodine, but the process is a secret one.

The following further information regarding the nitrate of soda trade of South America is furnished by M. V. L'Olivier. He states that the nitre beds were discovered in 1821 by Mariano de Rivero, but were not worked till 1831. The nitre is from 0·3 to 2 mètres thick, and forms irregular masses, alternating with beds of common salt and borate of lime at the height of about 1,000 mètres, and extending from 19° to 23·5° south latitude. He considers the presence of the nitre to result from the evaporation of once-present salt lakes. It is generally found covered by *costra*, which is a harder saline deposit, and has its own value. L'Olivier found samples of nitre and one of *costra* from the basin of the Loa to have the following compositions:—

Constituents	Nitre		Costra
	(1.)	(2.)	
Nitrate of soda .	51·50	49·05	18·60
Sulphate of soda .	8·09	9·02	16·64
Chloride of sodium .	22·08	28·95	33·80
Chloride of potassium	8·55	4·57	2·44
Chloride of magnesium	0·43	1·25	1·62
Carbonate of lime .	0·12	0·15	0·09
Silica and oxide of iron	0·90	2·80	3·00
Iodide of sodium .	sometimes traces	traces	—
Insoluble matter .	6·00	3·18	20·10

Some samples of nitre, however, contain from 60 to 70 per cent. of nitrate of sodium, and sometimes even it is

found pure and crystalline. The export duties which the Peruvian Government lay upon it are imposed with a view of preventing its competition with guano. These restrictions will tend to transfer the nitrate of soda industry to the basin of the Loa.

It is calculated that the 131 establishments in Peru could produce 780,000 tons per annum, although the actual production has never exceeded 300,000 tons. Of this article, during the first eight months of 1875 no less than 44,840 tons were imported into France.

Historical Notes on the Manufacture of Sulphuric Acid.—Sulphuric acid is first mentioned in the writings of Basil Valentine, of Erfurt, according to the statement of most historians. But Mr. Rodwell in his classical work on 'The Birth of Chemistry,' gives data from which we conclude it was known long before the time of Basil Valentine. Sulphur itself was well known and used in the making of matches in the time of Pliny; and apparently it was also burnt in a current of air and the sulphurous acid employed for bleaching purposes. Pyrites were used at this time for striking fire with steel in order to kindle timber, hence the origin of the name. Geber, an Arab of the eighth century, obtained sulphuric acid by distilling alum; but it was reserved for Andrew Libavius (died 1616) to prove that the acid procured by distilling alum or sulphate of iron is the same as that prepared by burning sulphur with saltpetre. Basil Valentine (born 1394), was well acquainted with the preparation of sulphuric acid, and used it for various purposes of dissolution. He obtained fuming sulphuric acid by distilling green vitriol after the manner still practised near Nordhausen. Mayow (born 1645, died 1679) considered sulphuric acid to consist

of 'nitre air united with sulphur,' meaning, of course, oxygen and sulphur. Under the phlogiston theory, sulphuric acid was sulphur which had lost phlogiston, and therefore its calx had become heavier—in our language it had taken up oxygen. Although Paracelsus, the Swiss alchemist, who died in 1541, was acquainted also with sulphuric acid, it was not till 1570, when Gerard Dornæus published his work, that anything like a correct account of it was given.

Sulphuric acid is found in many springs having connection with volcanoes, and is doubtless derived by combustion of the sulphur which exists so largely in those districts, together with slow oxidation.

The English makers originally prepared their acid by the distillation of green vitriol in earthen vessels, known as 'long necks,' placed within a reverberatory furnace, and connected with receivers of glass by means of lute. In this way fifty or more 'long necks' were at work in one furnace. 'Copperas works had existed in England from an early date; in 1748 they began at Hartley, and in 1797 at Walker. The copperas, after being dried, was placed in brick ovens, to which a strong heat was applied; the acid distilled off and was condensed, and formed an impure oil of vitriol. If 1 ton of copperas produced $1\frac{1}{2}$ cwt. of acid, it was considered a fair result. The price was 2s. per lb. or 220l. per ton. The present price being only 6l. per ton.' (R. Calvert Clapham, 'Account of Soda Manufacture on the Tyne.')

But this process of manufacture, owing to the intense heat required and the 'wear and tear' of the stills, gave way to the use of sulphur and nitre (1736), which were burnt in very large glass globes and the product concen-

trated by boiling in glass retorts or other vessels. This method of making sulphuric acid is attributed by Fourcroy to Lefevre and Lemery; but in this country it was first adopted by Dr. Ward, who called his product 'oil of vitriol made by the bell,' and which was sold at 1s. 6d. to 2s. 6d. per lb.

It was about the year 1746 that Dr. Roebuck, of Birmingham, in conjunction with his partner, Mr. Samuel Garbett, erected the first leaden chamber, but the use of the acid so made was confined almost exclusively to the neighbourhood, owing to the absence of canals and the danger of land carriage. It was consumed in the recovery of gold and silver from gilt and plated goods, for dissolving copper and making Roman vitriol. But three years later, these same men erected other works at Prestonpans, on the eastern coast of Scotland, and here they made experiments as to the use of sulphuric acid in whitening linen cloth. These experiments were published by Dr. Home, of Edinburgh, and led to the abolition of sour milk for bleaching purposes. Thus, a greater demand was created; and, in short, not only did they supply the United Kingdom, but also exported large quantities. In 1790 England exported 2,000 tons.

From time to time the size and form of the leaden chambers which were erected varied. In 1772, Kingscote and Walker's Works, at Battersea, consisted of seventy-one circular vessels, each of 6 feet diameter and 6 feet high. Previous to this, chambers of 6 feet and 10 feet square had been in use.

The introduction of chlorine as a bleaching agent, in 1788, gave an impulse of a great character to the manufacture of sulphuric acid; the working capacity of the

chambers was greatly increased, and as the result of observation, the height of the chambers was decreased, until the average dimensions may be stated to have been 60 to 80 feet long, 10 to 14 feet broad, and 6 to 8 feet high. This height contrasts strongly with a large chamber previously in use in Lancashire, of 120 feet \times 40 \times 20 feet high, and of capacity 96,000 cubic feet. The advantages of the sized chambers which now came into use are obvious, as they admitted of being built on a frame-work of timber, so that the bottoms could be easily repaired, the effects of gravitation secured, and the space below economised.

In the early days of the manufacture, 7 or 8 lb. of sulphur, carefully mixed with 1 lb. of crude saltpetre, constituted the proportions employed, and of this mixture 1 lb. was considered to feed 300 cubic feet of chamber-air. This mixture placed upon plates of iron or lead, and supported on stands of lead, was burnt *within the chamber*, a foot or two above the surface of the water, being ignited by a hot iron. The next improvement was the introduction of a distinct apartment for burning the sulphur. Mr. Parkes, in his 'Chemical Essays,' states that from 1 lb. of sulphur by this method he obtained $2\frac{3}{4}$ lb. of sulphuric acid of specific gravity 1.848. The furnace consisted of a round oven of firebricks of 4 to 5 feet diameter, and having the floor 2 feet from the ground, and a roof of brick, the crown of which was arched, and at its highest elevation 2 feet from floor. The air admitted was regulated by a small sliding door of tin plate, moving in the primary door of sheet iron. The sulphurous acid was conveyed away through the roof by an iron pipe of 12 inches diameter.

In the next phase of the manufacture the crude sulphur was worked with water into a paste, and the bricks, of about 20 lb. weight, dried on the top of the furnace. Contemporary with this improvement was the introduction of saltpetre pots, the saltpetre used being in the proportion of a tenth of the sulphur employed, with enough sulphuric acid to effect a proper decomposition. At the same time the gases were cooled by passage through water contained in a leaden vessel from which the water dropped into the chamber. In 1828 Kestner, of Thann, introduced in this country the use of steam in the chamber, and about the same time the 'drop tube' for testing the strength of the acid came into use. Up to this time the gases issuing from the chamber were passed into the chimney of the works.

The next great change in the history of the sulphuric acid manufacture was the substitution of pyrites for sulphur. It was in 1838 that the King of Naples granted a monopoly of the Sicilian sulphur trade to Messrs. Taix and Co., of Marseilles, in consequence of which the price rose from 5*l.* to 14*l.* per ton (Gossage). Recourse was therefore had to pyrites, and Mr. Thomas Farmer, in 1839, was the first in this country to make use of this substance, although it had been previously used in France. Moreover, a Mr. Hill, of Deptford, is said to have employed ore instead of sulphur in 1818. Spanish pyrites were first used in 1856, Belgian pyrites in 1858, Westphalian in 1861, and Norwegian in the same year.

These historical notes have brought us to the present mode of making sulphuric acid ; here, therefore, we shall not enter into improvements which have been effected since 1840, but shall proceed to study them in treating

of the manufacture as at present carried on in this country, in our next chapter. But there is just one point which may conveniently be noticed here. Of late there has been a demand in the aniline trade for very strong sulphuric acid, and Nordhausen acid has been imported to meet this demand.

Drs. Messel and Squire having occasion to take cognisance of this, turned their attention to the manufacture of sulphuric anhydride, and successfully worked out a process which they described in a paper recently read before the Chemical Society (April 20, 1876). Sulphuric acid of commerce is boiled in a platinum still, and the vapour is passed through a white-hot platinum tube; in this way it is almost completely decomposed into water, oxygen and sulphurous anhydride. From the platinum tube the mixed gases are led through a leaden worm cooled by water, whereby the greater portion of the water contained in them is condensed, and thence up a coke scrubber filled with coke, where the gases are thoroughly dehydrated by meeting a current of descending concentrated acid. The dry mixture of sulphurous anhydride and oxygen is now passed through platinum tubes, which are heated to low redness by the waste heat used for the decomposer. These platinum tubes contain fragments of platinised pumice, which effect the re-combination of the gases, and the product is condensed in a series of Woulffe's bottles. The platinum tubes, it may be remarked, are heated in an ordinary Hofmann's combustion furnace of a large size.

This process may thus be represented:—

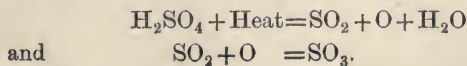

CHAPTER III.

MANUFACTURE OF SULPHURIC ACID.

IN the present chapter we propose briefly to indicate, in the first place, the *rationale* of the various processes entering into this manufacture, before we proceed to study each operation in detail.

The pyrites (iron and cuprous iron pyrites) are broken up into lumps about the size of pebbles, and are then roasted in a current of air, in an arrangement designated the 'burner.' By absorption of oxygen from the air, the iron becomes ferric oxide, while sulphurous anhydride is formed; thus—

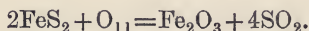

The gas passes into a flue, where it mixes with the vapour of nitric acid, generated in a 'nitre-pot,' from a mixture of sulphuric acid and nitrate of sodium—

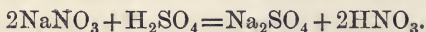

The mixed gases now pass on to what is called 'the chamber,' where, aided by the presence of steam, combination is effected, and sulphuric acid formed. The exact processes occurring in the chamber have been much debated; here we shall not enter into this discussion, but shall represent the process as taking place by virtue of the following reaction:—

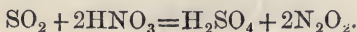

The sulphuric acid condenses in vesicles and falls to the floor of the chamber, where it is absorbed by water or dilute acid, while the nitric oxide resulting from the reaction indicated, takes up oxygen from the excess of air present, becoming nitric peroxide ($N_2O_2 + O_2 = N_2O_4$), which in its turn fulfils the functions of nitric acid as represented above. Finally, the residual gases from the last chamber (for chambers are worked in series), containing the nitric peroxide and all the nitrogen of the air which has been used, pass on to the 'absorbing columns,' which are arrangements which take advantage of the solubility of the oxides of nitrogen in strong sulphuric acid, to effect the removal of such oxides from the mixed gases, while the nitrogen escapes. The absorbing columns are known as 'Gay-Lussac's towers.'

The sulphuric acid from such towers loaded with the oxides of nitrogen is *denitrated* by blowing steam through it, and conveying the gases liberated in this way to the chamber; or, which is much better, the nitric compounds are recovered by causing the acid to come in contact with the sulphurous anhydride from the burners; this is effected in what are called 'Glover's towers.'

The most recent improvement in the manufacture of sulphuric acid, introduced by Dr. Hermann Sprengel, and consisting in the economisation of the steam used in the chamber by the use of water-spray, will be fully described together with other matters further on; so also, finally, will be described the manner in which the acid is concentrated to any desired strength.

The *pyrites burners*, while they are variously constructed to meet the requirements of each sort of ore, are all constructed on one principle, which aims at burning

off the whole of the sulphur with the minimum admission of air. This is a difficult matter to succeed in, because much of the oxygen goes to oxidise the iron from which the sulphur is abstracted, and thus an additional amount of nitrogen is introduced over that quantity, which corresponds to the oxygen calculated only upon the sulphur. Here and there, even now, is to be found a burner in use, which is of ancient date, and which was improved by Mr. Hunt. It is constructed on the principle of a lime-kiln, where the charge is introduced at the top, and the burnt residuum withdrawn below.

Without going through the lists of the various burners which have been in use, or proposed for use, it may be stated that up to a recent period it was usual to burn the pyrites in a series of twelve to twenty of a much smaller character than the form now commonly used. One of the best forms of burner, and one which may be taken as representing the others, was introduced by Mr. Harrison Blair; it consists in one large oven, which is charged once in twelve or twenty-four hours, and is provided with a slit arrangement in the door of the furnace for regulating the amount of air admitted. Its special advantage is the prevention of excessive dilution of the sulphurous anhydride by air, and with its use, a chamber of 25,000 cubic feet capacity is stated to give twenty-one tons of rectified acid weekly, against eleven tons by the ordinary old form of burner.¹

The amount of pyrites (after crushing in a mill and sifting from the finer portions) constituting a charge

¹ See 'Report on the Recent Progress, etc. of Manufacturing Chemistry,' by Drs. E. Schunck, Angus Smith, and Roscoe. ('British Association Report,' 1871.)

varies somewhat, but 5 cwt. per twenty-four hours per burner is one not uncommonly used.

For the sketches of an arrangement of pyrites burners (figs. 1 to 3), now largely used in alkali works, and of an

FIG. 1.

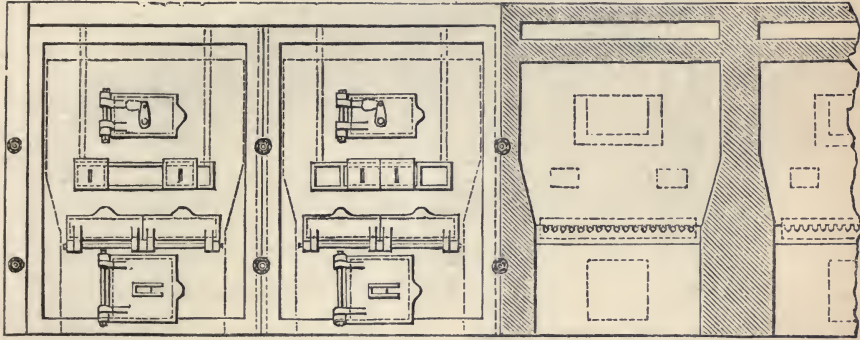
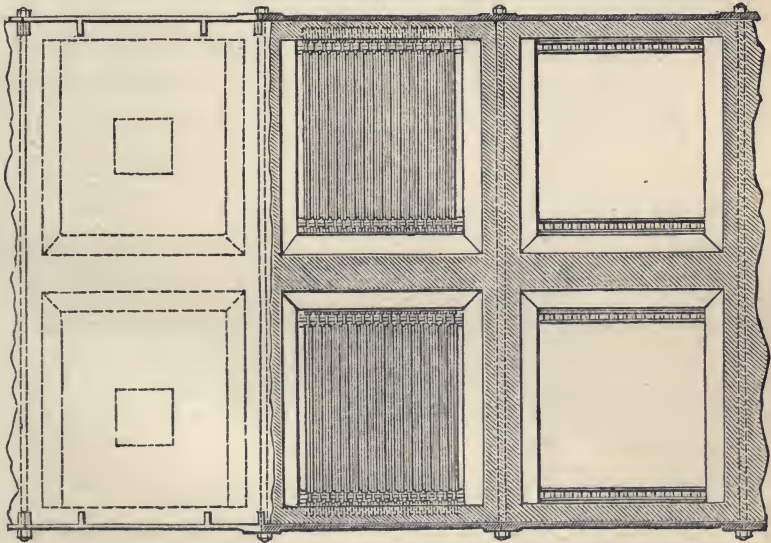

FIG. 2.



arrangement of twenty sets of burners, with nitre pots, and gas-conducting pipes, attached for conveying the gas

to the chamber (figs. 4 and 5), we are indebted to the courtesy of Messrs. Robert Dalglish and Co. of St. Helen's Iron Foundry, as also for other engravings bearing their

FIG. 3.

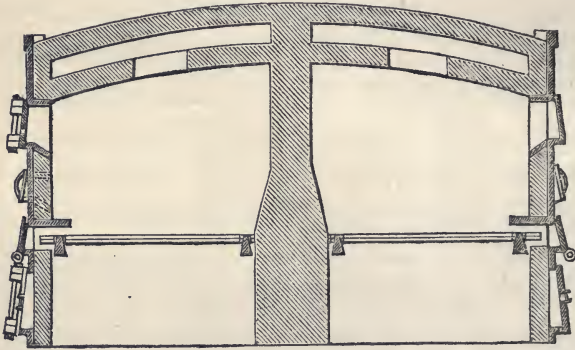

names. On the faces of the burners are to be seen the charging doors, stirring holes, and the slit arrangement for admitting and regulating the supply of air. The

FIG. 4.

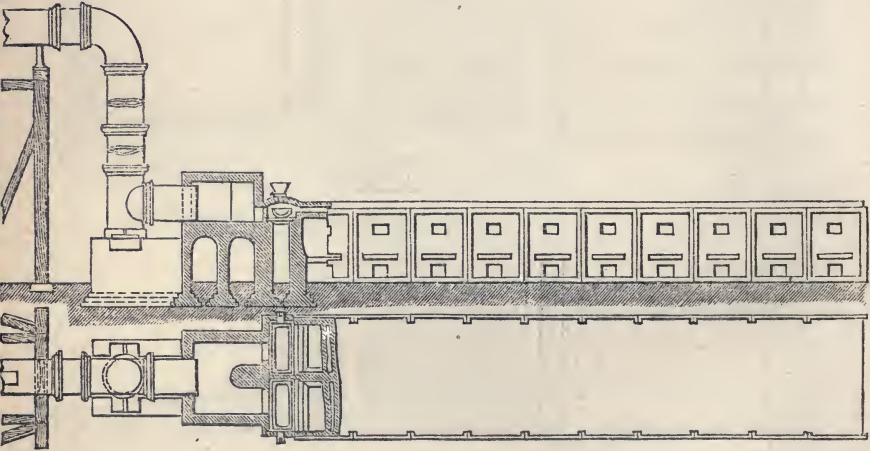

charge is withdrawn by tilting the bars upon which it rests, when the burnt pyrites fall to the floor and can

then be raked out. The whole burner is lined internally with firebricks, and near the centre of the roof there is a hole in each, through which the gases escape into a flue, running between the first roof of the burners and the second true roof. The usual size of the burner may be stated as about 6 feet 6 inches wide and 6 feet deep, as indicated by the burner front.

It has been stated that the pyrites after crushing are riddled from the dust and smaller fragments before being burnt. This is done in order that the air-passages to the burning pyrites may not become choked, and so prevent the perfect combustion of the sulphur. These powdered

FIG. 5.

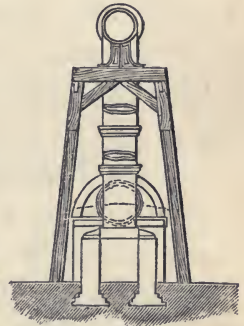

fragments of pyrites are designated 'smalls,' and many have been the special furnaces constructed for their combustion. One of the best of these burners was introduced by Mr. Spence, and employs a hearth of firebrick about 40 feet long by 6 feet wide, fired from below, and fed with air through an opening in the front governed by a damper. The material being introduced at the extremity furthest from the fire, is gradually worked up to the hottest parts, and so perfect combustion is secured. This mode of burning smalls is not largely in use at the present time, and even the plan of making them into bricks with clay (10 per cent.) to be then burnt in the kilns, has given way to a better. When clay was used, it was difficult to get anything like a perfect combustion of the sulphur, while the residual ore presented difficulties in working, and, consequently, degenerated in value. The method of treating 'smalls,'

now most usually employed, consists in stirring them with water and spreading them out to dry in thin layers on the tops of the furnaces. Oxidation there ensues with the production of a certain amount of sulphate of iron, which serves to bind the particles together, and in this agglutinated form compact masses are obtained which admit of burning in the ordinary kilns. In some works the amount of air admitted into the burners is regulated by controlling the egress of gases from the chambers. At other places Combe's anemometer is employed and fixed in a tube connected with the front of the burner. In any case the gases issuing from the chambers should not contain more than 2 to 3 per cent. oxygen. The residual ore after burning contains generally from 2 to 4 per cent. of sulphur, but with smalls the residual sulphur generally exceeds this quantity by 1 or 2 per cent.

In the burning of pyrites, white fumes are always generated along with the sulphurous anhydride. These fumes consist of sulphuric anhydride (SO_3), and have been ascribed as due to the decomposition of sulphate of iron, or to the concurrence of the sulphurous anhydride and moisture.

Wöhler long ago showed that by the passage of air and sulphurous acid over freshly formed ferric oxide (Fe_2O_3), a combination was effected. Recently A. Scheurer Kestner has described experiments, from which he concludes that these white fumes seen in the sulphur kilns, arise from a combination of sulphurous acid and oxygen, effected by means of the residual ferric oxide, which is stated to act as a carrier of the oxygen.

From the burners the gas passes into a flue which

has been described, where it meets other gas from other burners, and the whole body of gas now passes on to mix with the nitric acid prepared in the nitre pot, which is situated between the burners and the chambers.

The *nitre pots* are constructed of cast iron, and vary in size. Those now generally used are larger than those employed in times past, and like the one shown in sketch (fig. 6, kindly supplied by Messrs. Dalglish and Co.), are 4 feet 8 inches in length, and 1 foot broad. Smaller pots are preferred by some, for the reason that in the action of sulphuric acid on soda nitre (NaNO_3) great heat is evolved, and this, together with the heat of the burner gas, often drives off all the nitric acid quite suddenly. It must be

FIG. 6.

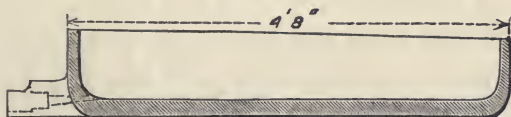

understood that in those works where 'Glover towers' are used for regaining the oxides of nitrogen issuing in gases from the chamber, the nitre pots are only worked at times, just to keep up the average working amount of nitric acid. We shall have more to say about the consumption of nitrate of sodium when we come to describe Glover towers, which are now in almost universal use. The quantity of nitre used varies from 3 to 4 or 5 per cent. on the sulphur burnt. From the 'nitre pots' the gases pass on to the '*chambers*' through an iron pipe 20 to 30 feet long (for cooling). These chambers are necessarily of huge size for three reasons: (1) On account of the large bulk of gases to be dealt with; (2) because air containing 79 per cent. nitrogen, therefore only contains

in 100 volumes 21 of oxygen for consumption; (3) because it is required that the gases in the chamber shall come into intimate mutual contact. The gases are conducted into the chambers at one end, and the chambers are supplied with syphon-arrangements and cisterns for carrying off and for storing the acid which is made.

Chambers are worked in sets of three to five, and it was usual in past times to section off the internal space by partitions of lead attached alternately to the floor and roof. The object of this arrangement was to more effectually mix the gases, but as it was found that these pieces of lead soon corroded, the use of them has been discontinued in most places.

The following are representative dimensions of sulphuric acid chambers:—(1) 75 feet long by 35 feet wide by 35 feet high; (2) 140 feet long by 24 feet 5 inches wide by 19 feet 5 inches high; (3) 100 feet long by 20 feet wide by 18 feet high. No. 3 constitutes a very good working chamber, and with the best advantage 1 cwt. of sulphur can be burnt in twenty-four hours for each 3,000 cubic feet of chamber-space.

There is a deal of divided opinion upon the most suitable-sized chamber to employ, and as to the best working conditions. Mr. H. A. Smith, who seems to have directed much attention to this manufacture, gives as the best form of chamber one of the following dimensions:—150 feet long, 25 to 30 feet wide, and 10 to 12 feet in height. He points out that the upper part of the chamber is of use principally as a reservoir for the gases, and that little or no reaction takes place at that part. This conclusion is based upon a number of experiments, in which he has estimated the relative amounts of sul-

phurous acid, sulphuric acid, and nitric acid, at certain stages of the passage of the gases through the chamber, and at heights of from 3 to 15 feet.

As the action takes place chiefly at the surface of the acid, in starting a chamber it is better to employ sulphuric acid on the floor of the chamber than water, to the depth of 2 or 3 inches. As to the quantity of the steam which has to be injected into the chamber, Mr. Smith states that it should increase in proportion to the increase of temperature, but should be less in volume than the combined volumes of the two gases. The temperature of the chamber should be about 93° C. (200° Fahr.), and the steam is generally injected at a pressure of from 10 to 11 lb. to the inch. Much steam is obtained in some works by utilising the waste heat from the pyrites kilns; but presently we shall discuss at some length an improvement which has been effected in reference to the consumption of water (as steam) in the chamber, and, consequently, in reference to the fuel used.

In building chambers which are to be used, say in sets of five, the first two should be of 7 lb. lead, and the others about 6 lb. This is because the first chambers ultimately contain the stronger, and therefore the heaviest acid. Muspratt was of opinion that the acid fluidified in the chamber as soon as formed, and that it then falls like rain to the floor, in which case the sides do not assist in liquefaction. Many manufacturers, endorsing this view, build large chambers accordingly.

The following working details of six chambers of 180 feet long by 21 feet wide and 20 feet high, during five years, are taken from an essay by Mr. M'Culloch:—
(1) Temperature of chambers 160° Fahr. but receiving

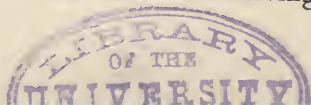

chamber only 90° Fahr. ; (2) 28 cubic feet space per pound of sulphur per twenty-four hours, giving an average production of 284 per cent. oil of vitriol on the sulphur consumed in forty burners, but without the employment of Glover towers ; (3) to obtain a good production the 'drops' from the strong chamber should test 130° to 135° T., and from weak chamber about 100° T. ; (4) 280 to 290 parts of oil of vitriol of sp. gr. 1.85 on 100 parts of sulphur is a good production, theory requiring only 306 oil of vitriol of that sp. gr. ; (5) a better return is made on 286 to 294 of acid of sp. gr. 1.846 on 100 of sulphur.

We have spoken above of chamber 'drops.' These are supplied from an apparatus known as a 'drop tube,' which allows an observer to take the strength of the acid contained in the chamber. Sprengel has invented an apparatus for gauging the depth of liquid on the chamber floor, and for withdrawing a sample of all the heterogeneous layers of liquid for determining the mean specific gravity. This apparatus consists of a graduated tube of glass, provided with a caoutchouc piston. When the acid in the chamber attains a specific gravity of about 1.6 it is withdrawn, and either used in that state, or purified, or concentrated. We will now consider the improvement which has been introduced into the sulphuric acid manufacture quite recently by Dr. Sprengel, and in doing so we shall quote from facts kindly furnished us by that gentleman himself.

About 1,000 tons in every 2,000 tons of chamber acid consists of water which has once been steam as injected into the chamber, and therefore has occupied space, and by its heat expanded the bulk of the gases, a condition of things unfavourable to acid making. For it

may be said that by lowering the temperature of chamber-gas a shrinking of its volume is effected, a condition which favours the formation of sulphuric acid. With this knowledge to work upon, Dr. Sprengel has introduced into the manufacture a patented process for substituting chamber steam by *pulverised or atomised water or spray*. This is done by causing some steam to escape from a platinum jet under a pressure of about two atmospheres into the centre of a flow of water, as shown in the adjoining sketch (fig. 7).

Twenty pounds of steam thus convert 80 lb. of water

FIG. 7.

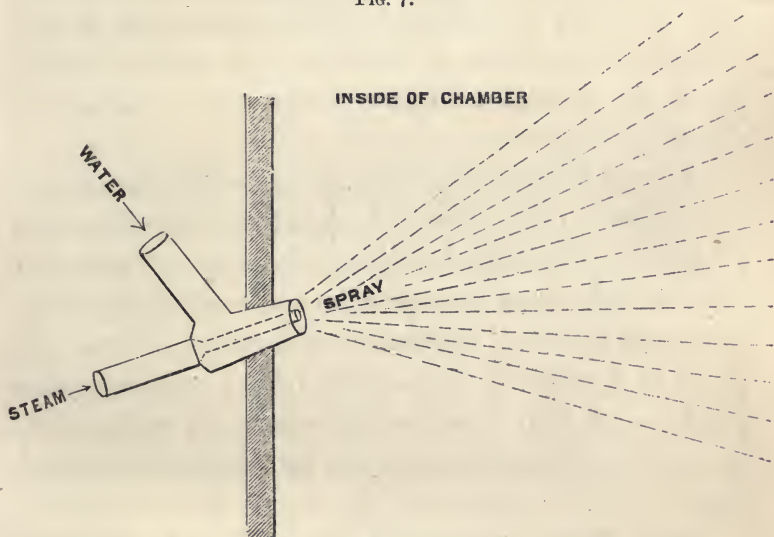

into a cloudlike mist at the rate of about one-third of a ton in twenty-four hours. These jets are placed in the sides of the chamber about 40 feet apart. Where this process has been at work on a large scale (Barking, in Essex), nearly two-thirds of the quantity of coal formerly burned for steam production have been saved, while its

employment brings about those conditions of temperature and volume of the chamber gases which we have indicated as favouring the production of oil of vitriol. There seems to be no doubt that from the very nature of this improvement, and the simple way in which it works, that it will be largely adopted.

Dr. Sprengel also proposes in his patent to use the spray for effecting the absorption of the lower oxides of nitrogen contained in or escaping from the acid chambers; and he has also patented the use of nitrous sulphuric acid (as obtained in the Gay-Lussac towers) to be injected into the chambers in the form of spray likewise, so as to utilise the oxides of nitrogen contained therein. This he proposes as a substitute for Glover towers, which, as we shall see below, perform very successfully the same function.

As may be supposed, many attempts have been made to supersede the costly lead chambers, but they have all failed. The materials that have been proposed as substitutes for lead include stone and earthenware (Leyland and Deacon), vulcanised indiarubber, slates, and plates of a material consisting of 70 per cent. stoneware powder and 30 per cent. sulphur (Simon); gutta percha is much more rapidly destroyed by sulphuric acid than lead.

With these observations we will now return to consider the treatment of the gases as they issue from the chambers. These gases consist of nitrogen derived from the air, 2 to 3 per cent. oxygen, and all the oxides of nitrogen which have served the purpose of carrying the oxygen of the air to the sulphurous anhydride. The oxides of nitrogen were originally generated

as nitric acid from a mixture of soda nitre and sulphuric acid. We have seen that, owing to the restrictions made on the nitre trade by the Peruvian Government, its use forms an item of considerable expense in the manufacture of sulphuric acid. Therefore it is, that many attempts have been made to recover these oxides of nitrogen existing in the gases issuing from the chambers.

It is more than thirty years ago, since Gay-Lussac proposed to effect this desideratum by the use of strong sulphuric acid, which has the property of absorbing oxides of nitrogen, and this proposal was first carried into effect at the works of St. Gobain. In this way the consumption of nitre, which originally amounted to from one-eighth to one-twelfth of the weight of sulphur burnt, was reduced by one-half, or even in some cases by two-thirds that quantity. The 'absorbing columns,' as they are termed, are virtually leaden towers supported on a timber of framework, high and narrow, and packed with lumps of coke about the size of eggs. The vapours from the chambers are led into these towers at a point in one side near the bottom, and in their ascent up through the towers they encounter a current of sulphuric acid of 1.76 sp. gr. flowing downwards over the coke. The acid used for this purpose is stored in a cistern over each tower, to where it is pumped by means of a forcing engine. In its descent through the tower the acid absorbs the nitrous compounds and is stored in a reservoir, while the unabsorbed gases pass into the flue and are carried away. It is now necessary to recover from, and restore to the chamber, the nitrous compounds dissolved in the acid, and this was done until recently as follows:—

The acid was pumped up to the top of a second

similar tower, after some dilution with water, and here it was allowed to flow in its descent over coke, while it experienced an ascending current of steam which deprived it of the nitrous compounds, which, along with the steam, passed into the chambers, while the acid, by absorption of water, became considerably diluted (to 1.615 sp. gr.), and flowed off at the bottom ready for concentration. These latter towers are known as 'denitrating columns.'

They are sometimes constructed as follows:—A cast-iron pipe, 9 feet by 3 feet, is lined with lead, and provided with a further lining of half-thick bricks, with pipeclay as mortar. This is set on end and packed with flints, being connected with the chamber by means of a fire-clay pipe, which conveys the nitrous gas issuing from the other end. The nitro-sulphuric acid enters at the top and trickles over the flints, meeting from beneath the steam. The acid is thus reduced from 148° T. to 104° T. and raised from 60° Fahr. to 300° Fahr. and on cooling, gives acid of 128° T. containing traces of nitrous compounds. Mr. J. McCulloch, working in this way, has published results, from which we gather the following figures:—Using 25,000 tons pyrites annually, an average of 3.5 per cent. nitre has been consumed, but the process has the drawback of requiring 3 or 4 tons of coal per twenty-four hours, to boil up as much weak acid as is required to make strong acid to absorb the nitrous compounds accompanying the conversion of 12 tons of sulphur into sulphuric acid.

Notwithstanding these methods of working, in them there are three distinct sources of loss of nitrous compounds, amounting in all to about 3 to 6 per cent. of the

soda nitre used :—(1) The chamber acid invariably retains some in solution, although its maximum strength does not exceed 1.60 sp. gr.; (2) a certain amount escapes absorption in the Gay-Lussac towers; (3) after the denitration by steam of the acid from the absorbing columns, a certain amount always remains in the acid.

Some few years ago Mr. John Glover introduced into the trade an improvement on the plan just described for denitrating acid. Mr. Glover's plan is now in almost universal use, although the steam process is still used at some works.

This method of denitration is carried out in what are known as 'Glover towers' (10 feet by 6 feet internal diameter), which are built of lead, and lined with brick. Up these towers pass all the products of combustion from the pyrites kilns (or burners), and thus enter the tower at a temperature of about 600° or 700° Fahr. The hot gases meet a descending stream of mixed nitro-sulphuric acid from the Gay-Lussac tower, and weak acid from the chambers, thus thoroughly *denitrating and at the same time concentrating* the whole of the acid to a density of 145° to 150° T. The nitrous compounds given off in the interior of the tower, along with the steam evolved in concentration and sulphurous anhydride, being carried into the chambers. The issuing acid is then taken either to the Gay-Lussac tower to again absorb the nitrous compounds from the chamber-gas, or otherwise used as needed. By the use of this tower the economic value of the Gay-Lussac tower is fully realised, as an abundant supply of strong acid for it is obtained without any expenditure for fuel for concentrating the acid.

The saving of nitre alone, is said by Mr. Glover to be

at least half to three-quarters of what was formerly used, while a better yield of acid is obtained from the sulphur burned, and an escape of sulphurous anhydride into the atmosphere is prevented.

Two objections have been urged against Mr. Glover's process, namely, an alleged danger of the lead or packing giving way, thus necessitating repairs and laying-off chambers, and the reabsorption of nitre in the columns.

But Mr. Glover has met these objections and refuted them. He states that these objections never exist with 'a properly proportioned and worked tower.' He has had a tower in use for five years without interfering with the packing, and after six years the lining is still good. The acid rather contains sulphurous acid than is imperfectly denitrated. The same tower in converting 1,651 tons sulphur (from Norwegian pyrites) required 63 tons 13 cwt. of nitre, or .3·8 per cent.; chamber-space being 1 sulphur per twenty-four hours to 20 cubic feet, and all the acid made being by the same process concentrated to 140° to 150° T.

Another advantage attached to the use of the Glover tower is that all the water formed as steam in the denitration by the sulphurous anhydride goes to the chamber, and so an economy in the steam generated direct by fuel is effected. Another alleged danger of the use of Glover towers is the contamination of the acid by iron carried up in the current of sulphurous anhydride from the burner. But R. Hasenclever finds that in his hands, by the Glover system, the acid contains only 0·05 per cent. of iron.

It has been also said that a serious source of loss is encountered under certain circumstances in working with

these towers, viz., in the reduction of the higher oxides of nitrogen to monoxide, or even to nitrogen itself, although it has been also allowed that such a reduction takes place when Glover towers are *not* used, if the proportion of free oxygen entering the chamber be too low.

However, to conclude this review of *pros* and *cons*, it may fairly be said that Mr. Glover process bears the stamp of success, and is the most advanced process of the day for denitrating nitrous sulphuric acid.

Through the kindness of Mr. William Glover we are enabled to give an engraving of the tower (figs. 8 and 9), which is self-explaining. All we need add is, that the towers are supplied with the nitrous sulphuric acid by means of a Barker's mill in some works, which arrangement equally distributes the acid over the area of tower.

In conclusion, what has been stated in detail may be represented as follows:—Taking the squares to indicate the various pieces of plant in the order in which they are arranged in the most modern way of manufacturing sulphuric acid, then we have—

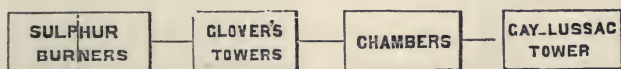

In the burners, sulphurous anhydride is generated, and passing with air and nitric acid into the chambers, meets with steam or atomised water and forms acid. From the chamber-gas the oxides of nitrogen are abstracted by strong sulphuric acid in the Gay-Lussac towers, and from this product the oxides of nitrogen are taken and restored to the chambers in the Glover towers, which also prepare strong acid for the Gay-Lussac towers.

Concentration of Sulphuric Acid.—The acid of 1·6

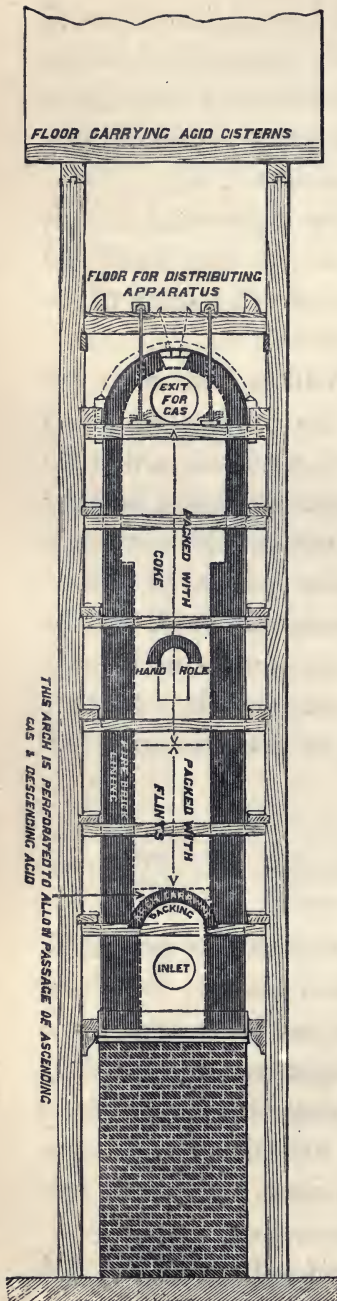

FIG. 8.

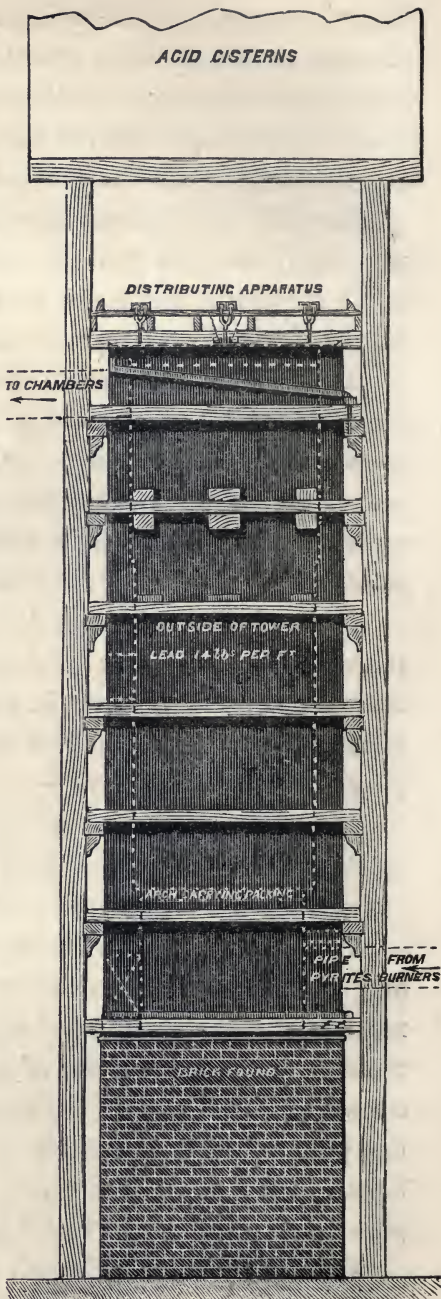

FIG. 9.

sp. gr. (71 per cent. H_2SO_4) from the chambers, is strong enough for the manufacture of salt cake, but as it is not strong enough for many other purposes it has to fulfil, its concentration has to be effected. At first this concentration is allowed to proceed in leaden pans placed on plates of cast iron, which are heated direct by fire and lined with clay and fire-bricks until, in fact, its density is 1.720 (82 per cent. H_2SO_4). At this stage it forms the 'brown vitriol' of commerce, which is much used in the manufacture of phosphatic manures. This degree of concentration is often effected by the waste heat of the burners. The pans are not filled deeper than 0.35 metre height (or 15 inches) of acid; nevertheless, the wear on them is chiefly on the bottom. This doubtless arises from the combined action of fire and pressure exerted by the weight of the acid. When well managed, 1 cwt. of 60° B. acid may be obtained from acid of 50° by 16 or 18 lb. of coal on the average (F. Bode).

Beyond a density of 1.720 the concentration cannot be effected in leaden pans, not so much on account of any action on the lead by the acid, but owing to an action brought about by the acid, through the high temperature at which it boils,—two dangers thus appearing—melting of the lead, and its corrosion by the acid. Pure and soft lead is more affected by acids than the harder varieties. To further concentrate the acid, recourse was originally had, as stated in the previous chapter, to distillation in glass retorts. These, however, gave way to alembics of platinum of capacity 10 to 30 gallons, and costing from 400*l.* to 800*l.* In these the concentration proceeded to 1.845 sp. gr. (100 per cent. H_2SO_4). At this stage sulphuric acid passes over, and, indeed, long before it

arrives at this state much acid is carried over with the water, but means are taken to condense it and return it to the chamber.

Platinum retorts, however, are costly, and are much more readily attacked by acid than might be imagined. This is especially the case with acid containing an undue proportion of nitrous compounds. Kestner found that when an alloy of platinum and iridium was employed, this destruction was much less, but then such an alloy is far less malleable than platinum alone, and therefore far harder to work.

The cost of a retort in these days is about 4,000*l.* for one capable of yielding half a ton of finished acid per day. In Germany a platinum still costs from 30*l.* to 48*l.* per kilo. But, although they are still used here and there in England, and to a great extent on the Continent, yet, practically, here at home they have been abandoned, and have given way once more to improved glass retorts (lead glass) heated by an open fire or in iron pots with sand. Moreover, this method has the advantage of rendering the progress of concentration evident by the loss of brown colour.

In 1850, Mr. Clough, of America, patented the concentration of the acid, by surface heating in leaden pans, which are placed in water and lined with fire-bricks, and covered with a low arch of brickwork. Over the surface of the acid, the flame of a reverberatory furnace is passed. But this promising method is attended with a considerable loss of acid, and after a time the leaden pans are also attacked.

In the same year Mr. Gossage (junior) patented the concentration of sulphuric acid by its distribution over

pebbles contained in a leaden tower. From below, the acid was met by a current of hot air, produced by the combustion of coke; but unfortunately here also, there was a great loss of acid by evaporation in the vesicular state.

It may be stated, that beyond concentrating the acid to the strength at which it is employed for making sulphate of soda, these operations are carried on at distinct works.

Some short time ago a method was discussed in the columns of the 'Chemical News' for concentrating sulphuric acid, which seemed somewhat promising. The method originated with Mr. John Galletly and Mr. James Stoddart, simultaneously and independently.

Mr. Stoddart points out, that by heating the acid to 300° Fahr. (a temperature maintained by fire) in a current of air, the brown acid of 1.700 sp. gr. can easily be made, and at a temperature of 500° Fahr. (also in a leaden pan), by these means, concentrated acid. Mr. Galletly has repeatedly concentrated a gallon of brown vitriol in a small leaden box, with a depth of acid of 4 to 5 inches, and a temperature varying from 190° C. to 210° C. till its sp. gr. = 1.840. Paying especial attention to the lead box, he concluded the action of the acid to be very slight, of course through working at such a comparatively low temperature. On another occasion he prepared from brown vitriol (of 1.745 sp. gr.) 5 gallons of 1.830 sp. gr. at 205° C. in an hour, using $16\frac{1}{4}$ cubic feet of air. The loss of monohydrated acid was 11.19 per cent. as against 8.8 per cent. by concentration in glass bottles. At first the evaporated water was practically free from acid; the last fourth had a sp. gr.

of 1·070. He points out that enough heat, even from the best-built pans, might be economised and utilised to propel a small engine for blowing the requisite air.

Mr. F. Bode has commented on these proposals at some length. He points out that, in employing the above method, deeper pans than those usually employed would have to be used, and this would necessitate a thorough support at the bottom, owing to the increased pressure of the hot acid. Further, it would be necessary to cover the pans with a hood, to prevent mechanical losses by spiriting, and, even so, the formed steam would carry over some acid in a vesicular state not easily recoverable. At any rate, the method is worth trying further, although, practically, it is the same method as that of Mr. Gossage, above alluded to, and open to the same objections.

Before leaving the subject we must allude to the method which employs super-heated steam; this originated with Carlier, of Drusberg, and is now employed, according to R. Hasenclever, in many works in Germany. The acid is placed in leaden-lined wooden tanks of 4 mètres square, and provided at the bottom with two coils of leaden pipes, 45 mètres long, 0·03 mètre internal diameter, and 0·007 mètre thickness of lead. Through these coils high-pressure steam is forced, until the sp. gr. of the acid is 1·7, when it is run into another tank, through a serpentine leaden coil of pipes, so that it reaches the second tank in a warm state, and there the evaporation is continued. In an apparatus as here mentioned, 5 tons of chamber acid are concentrated to 1·7 sp. gr. in twenty-four hours, with steam at a pressure of 45 lb. to the square inch—a temperature 135·1°,

employing a quantity of fuel amounting to 9 per cent. of the acid concentrated. The advantages of this method are, first, the prevention of loss of acid by employing a low temperature, and the non-contamination of the acid by impurities.

According to MM. Favre and Kessler, there are thirty-nine platinum alembics of a peculiar construction at work in twenty-six works in France. They are composed of wide, shallow, platinum cisterns, covered with a leaden hood with double walls between which water circulates to keep them cool. Connection between the cistern and the leaden cap is effected by a hydraulic joint. These cisterns are fed by means of a leaden pipe, with acid of 60° B., and deliver full-strength acid through a pipe of platinum.

Scheurer Kestner has recently determined the solubility of platinum in sulphuric acid at various degrees of concentration. With acid free from nitrous compounds, 1 gm. of platinum is dissolved per 1000 kilogrammes of acid concentrated to 94 per cent. When carried to 98 per cent. 6 or 7 grms. of platinum dissolve per 1,000 kilogrammes of acid concentrated, and 9 grms. when carried to 99·5 per cent. H_2SO_4 . In the presence of nitrous compounds much more dissolves.

Statistics of the Sulphuric Acid Trade.—A small works will turn out about 150 to 200 tons of acid annually, while a large one will often make more than 4,000 or 5,000 tons per annum. When it is to be sold or exported, it is packed in carboys holding from 11 to 12 gallons, and containing about 200 lb. each.

‘In 1830 the produce of acid on the Tyne may be calculated at about 3,300 tons, and advancing to 1867,

and acting on more certain returns, it appears that the production of sulphuric acid has increased to 140,000 tons' (R. Calvert Clapham). Professors Schunck, Angus Smith, and Roscoe estimated that 700 tons of sulphuric acid, of sp. gr. 1.85, were annually produced in the Lancashire district, exclusive of that used for soda-ash making. Besides its consumption in the soda trade, it is largely consumed in the manufacture of soap, glass, hydrochloric and nitric acids, alum, superphosphates (manures), sulphate of copper, and in bleaching and dyeing. A true estimate of the 'total make' of sulphuric acid can only be arrived at from a knowledge of the amount of it used in these industries. Such tables we shall give in a later chapter.

Strength of Sulphuric Acid of different Densities at 60° Fahr. or 15.5° Cent. (Ure) (Abridged).

Specific gravity	Percentage H_2SO_4	Specific gravity	Percentage H_2SO_4	Specific gravity	Percentage H_2SO_4
1.8460	100	1.7901	88	1.6624	76
1.8415	98	1.7728	86	1.6415	74
1.8366	96	1.7540	84	1.6204	72
1.8288	94	1.7315	82	1.5975	70
1.8181	92	1.7080	80	1.5760	68
1.8070	90	1.6860	78	—	—

Purification of Commercial Sulphuric Acid.—Commercial sulphuric acid is always contaminated with lead, and generally with arsenic, as we have already shown.

A method, adopted in several Continental manufactories, for separating arsenic from oil of vitriol, consists in heating the chamber acid with the necessary amount of sodium hyposulphite at a temperature of

70° or 80°, with some stirring. Sulphide of arsenic separates out and collects in flakes on the surface, while the acid containing an equivalent amount of sodium sulphate is withdrawn from below. The arsenic can also be removed by the use of sulphuretted hydrogen, or of barium sulphide; if the latter be used, sulphuretted hydrogen is generated, and this forms sulphide of arsenic, whilst the barium as sulphate remains undissolved.

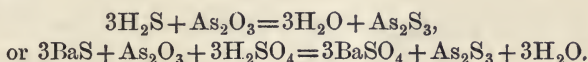

Lead can be removed from the acid by dilution with water, when lead sulphate is precipitated; but when this method is used, it is necessary to concentrate the acid again afterwards.

Notes on the Sulphuric Acid Trade in the South of France.—According to M. A. Favre, the sulphuric acid is entirely obtained from pyrites roasted in furnaces capable of revolving on their axle. The depth of the kiln being 1·80 m. and its surface 1·20 m. The pyrites are burnt down to 2 or 3 per cent. sulphur, while the combustion is incomplete in many works owing to the use of too shallow layers of pyrites, so that the burning is carried on too briskly. He approves of the following proportions:—180 cubic mètres of chamber space to 1 square mètre of surface of kiln grating, upon which are burnt every twenty-four hours 270 kilos. of pyrites at 40 per cent. sulphur, corresponding to 150 kilos. of pyrites to 100 cubic mètres of chamber-space. He considers that the capacity of the chambers may be better utilised by cooling the gases before they enter them. The chambers are generally worked in sets of three, one

large and two smaller ones, and for the larger chamber the most approved dimensions are 45 mètres long, by 8 in width and 6 in height; the three chambers giving a total cubic bulk of 4,000 cubic mètres. The cost of 1,000 kilos. of acid at 50° B. is stated at 36·9 fr.

Other Processes Proposed for Making Sulphuric Acid.—One cannot insist too strongly on the importance of keeping up a knowledge of old processes and suggestions, for, after all, our new processes are, in a limited sense, old processes improved. Industrial processes, like scientific laws, are generally the accumulation of individual experiences rather than the work of one man. One notes a fact, another extends the observations, a third generalises, a fourth discerns a principle, and a fifth beyond recognising, establishes it. We shall therefore offer no apology for once more placing on record the following old processes:—

(1) Shanks proposed to decompose gypsum with chloride of lead $\text{CaSO}_4 + \text{PbCl}_2 = \text{PbSO}_4 + \text{CaCl}_2$, and then to decompose the PbSO_4 with hydrochloric acid: $\text{PbSO}_4 + 2\text{HCl} = \text{PbCl}_2 + \text{H}_2\text{SO}_4$. The acid is removed and concentrated; the PbCl_2 is used over and over again; the CaCl_2 is wasted.

(2) McDougall and Rawson patented the passage of sulphurous acid through nitric acid. Sulphuric acid and nitric oxide are formed, the latter being converted into peroxide by air, and this is again decomposed by water into nitric acid and NO_2 . The difficulty of the process is presented in the management of the apparatus. There is also a great wear and tear on the plant.

(3) Keller obtained sulphuric acid from lead sulphate as follows. He obtained hydro-sulphuric acid, amongst

other methods, by exposing sulphate of calcium or barium with coal and sand to steam in a heated state. The hydrothion was conveyed into vessels holding in suspension (in water) PbSO_4 . Sulphide of lead was precipitated and yielded more PbSO_4 by roasting, while sulphuric acid passed into solution.

(4) Margueritte decomposed clay with chloride of magnesium, giving hydrochloric acid, which was used to decompose phosphate of lime. He then decomposed sulphate of lime by phosphoric acid, reproducing phosphate of lime and giving sulphuric acid.

(5) Schmersahl and Bouct passed a mixture of sulphurous acid, air, and steam through horizontal pipes of clay or iron, filled with asbestos, pumice, or other porous material, and heated in a furnace. But even before this, as already pointed out, Wöhler had discussed the facility which CuO , Fe_2O_3 , Cr_2O_3 , at a low red heat, have for giving sulphuric acid in this way; but at Oker the attempts which were made to carry out these reactions on a large scale, did not prove satisfactory.

(5) Döbereiner was the first to suggest the use of spongy platinum for making sulphuric acid without chambers.

(6) Under the heading 'Alkali Waste' other processes, including Gossage's and Duclos', will be given.

CHAPTER IV.

THE TREATMENT OF BURNT PYRITES ; EXTRACTION OF COPPER, SILVER, AND GOLD ; AND THE MANUFACTURE OF SULPHATE OF COPPER.

IN the present chapter we shall discuss the various methods adopted for extracting from the burnt residuum from the pyrites kilns, the several metals contained therein, and the utilisation of the unburnt sulphur. These several operations are often conducted in special works, but the industry is so essentially a part of the alkali trade as to warrant its complete study here.

In times gone by, the employment of cupriferous ores for acid making was avoided as far as possible, but now that processes have been devised for extracting the copper, these ores have come largely into use, and are quickly supplanting the other forms of pyrites. H. L. Pattinson and Co. began to smelt copper ores obtained from burnt pyrites in 1858, but for the most part, in those early days of the trade, they had to be sent to Swansea to undergo this extraction. But since copper works were erected at Hebburn in 1865 to carry out this extraction by the so-called 'wet method' of Mr. Henderson, this example has been followed, and thus the expense of sending the ores to Swansea has been rendered unnecessary. This process, so successfully worked out by Mr. Henderson, we shall now describe, but, before

doing so, we give the following analyses made by Mr. Thomas Gibb, showing the amounts of copper and silver contained in the burnt residuum of the chief varieties of pyrites :—

Kind of ore	Copper, per cent.	Silver
Rio Tinto	3·80	1 oz. 4 dwts. per ton.
Tharsis	3·50	15 „ „
San Domingo's (Mason's).	3·70	15 „ „

Mr. Henderson's process begins by fluxing the burnt pyrites with common salt, employing both in the state of powder, at a low red heat. The sulphur present forms sulphate of iron, which decomposes some of the salt, producing therefore sulphate of sodium and chloride of copper. Any chloride of copper that may sublime and pass away with the hydrochloric acid which is generated, is condensed with the latter in Gossage's towers, and the liquors so obtained can be afterwards used entirely or partly to lixivate the furnace product. This lixiviation is effected by water and the acid described, in wooden tanks; the acid assisting most effectually in dissolving out the metals. In this way liquors are obtained consisting of chlorides of copper, silver, and lead, with undecomposed salt and sulphates of sodium and lead. These liquors are now precipitated in tanks by scrap iron, or what is better, because of its more rapid action, spongy iron, which latter is made by heating burnt pyrites with coal in a muffle furnace.

The copper so obtained is washed, drained, and partially dried, after which it is smelted in a reverberatory

furnace, yielding what is termed 'pimple' copper (60 per cent.), and this when melted in a current of air in a similar furnace, is purified by the oxidation of impurities which proceeds, and gives blister copper (86 per cent.), which is lastly refined into 'finished' or 'ingot' copper, ready for the market, and containing 96·5 per cent. Cu. Mr. R. Calvert Clapham gives, as the rough analysis of the tank residue remaining after the precipitation of the copper, the following:—Peroxide of iron, 90 tons; silica, 6 tons; water, 4 tons: total, 100 tons. This is largely used for 'fettling' in puddling furnaces, and in blast-furnaces, where it takes the place of hæmatite. Mr. Henderson's process for extracting the copper, it may be remarked, likewise applies to weak copper ores. The copper is dissolved out of the sandstone by hydrochloric acid, and from the liquors the copper is precipitated by iron.

It has been seen that the ores used in the sulphuric acid manufacture often contain a considerable quantity of arsenic, and a good deal of this remains in the burnt residuum (about 0·5 per cent.), and ultimately in the above process is precipitated more or less with the copper. Now the presence even of traces of arsenic in copper, renders it extremely brittle, and such copper finds anything but a ready sale in the market. It is, therefore, a matter of importance to rid the copper of this impurity. This is done successfully at the Tharsis Works by a process patented by Mr. Down in 1870. This process is said to consist in treating the acid copper liquors, obtained as described above, with such an amount of lime or calcic carbonate as is sufficient to neutralise a great deal of the excess of acid present. But, according to the

specification, the copper liquors are by preference allowed to remain in contact with the lime 'until the salts of iron present in the solution with the copper begin to precipitate.' The solutions are then run off into the tanks, where the precipitation of the copper by metallic iron takes place. Now Mr. Down claims that by this process, while the excess of acid is neutralised, and thus an economy in the amount of iron used for precipitation of the copper, effected, there is yet sufficient acid left in the solution to allow of that precipitation, and at the same time to keep the arsenic and antimony in solution. He further states that arsenic and antimony are precipitated with the copper only when the liquors are very acid, so that by working his process the copper is obtained free from these metals. Now, while we do not for a moment doubt the utility and practicability of the process, we are inclined to interpret the changes effected in a way somewhat different to Mr. Down. That he gets the copper free from arsenic we know, for we have on several occasions examined such liquors after treatment by his process, and found them free from arsenic. But where we are inclined to differ from him is in the chemistry of the process by which the arsenic has been removed. And here we are writing from personal knowledge; for, in fact, soon after the date of Mr. Down's patent, we were engaged in working with some processes devised for the same purpose.

We have seen that Mr. Down preferably allows the liquors to remain in contact with the lime until the salts of iron begin to precipitate; and although he expressly says that in such case the greater amount of the arsenic and antimony remain in solution, we are yet disposed to

think that the arsenic and antimony are actually removed by the precipitate of ferrous oxide which occurs at this stage, although it is of course small in amount. It has been our universal experience, that whenever the acid copper liquors, of which we are writing, are treated either with lime in sufficient quantity to precipitate a small quantity of ferrous oxide, or are treated with ferric oxide itself, then all the arsenic present is removed by the precipitate, in combination, in a form similar to that in which arsenic exists in 'Scheele's green'; the only difference being that in 'Scheele's green' copper exists in the place of iron. Thus 'Scheele's green' is CuHAsO_3 ; whereas the iron compound may have a formula FeHAsO_3 , or more probably, FeAsO_3 , or the arsenic may be precipitated in combination with the lime. If our view of the process be correct, it would prove desirable to perform the process in separate tanks to those in which the copper is precipitated by the iron, otherwise the copper would still be contaminated with the arsenic, although in a different form. This is important, because, Mr. Down says, 'the neutralisation may be effected wholly or in part in the precipitating vats.' But, apart from the criticism we have made, one thing is certain, that the process, when carried out in a certain manner, gives excellent results and yields copper free from arsenic.

The utilisation of the sulphate of sodium existing in the mother liquors, after the precipitation of the copper, has likewise been attempted by Dr. Merz and Mr. Napier, and will, doubtless, shortly be a matter of consummation. Mr. Calvert Clapham points out that this new copper-extraction industry has had the effect of decreasing the mining of native ores, with a corresponding increase in

the importations; so that whereas in 1860 no less than 15,968 tons of native ore were raised, in 1869 only 8,291 tons were raised, equal to a reduction of nearly 50 per cent. The copper made from 'burnt ore' in 1869, on the Tyne, amounted to 4,100 tons, and in Lancashire and other places to 3,500 tons: total 7,600 tons. This copper trade has reduced the cost of sulphur to the soda maker 40 per cent. since 1865.

We will now proceed to consider processes which have been devised and used for extracting from burnt pyrites the small amounts of precious metals contained therein.

We give here Augustin's process for extracting silver from its ores, although it is not employed in the extraction from *burnt* ore of its silver. It is yet the basis of several suggestions, and is of interest. The ores are roasted with salt and the mass lixiviated with a solution of salt, to dissolve out the chloride of silver. By dilution, silver chloride would be precipitated, but it is found preferable to precipitate the silver by copper, with formation of cupric chloride; the presence of which does not interfere with its use for extracting fresh quantities of chloride of silver. An improvement on this process was made by Ziervogel, who avoids argentic chloride altogether, and merely roasts the sulphurous ore in such a manner that the sulphates of iron and copper are completely decomposed, whilst the argentic sulphate remains undecomposed, as it withstands a much higher temperature.

To effect this, the roasting is continued until sulphurous acid is no longer evolved and the mass yields no sensible amount of sulphate of copper to water. The argentic sulphate is extracted by boiling water, and the silver is

precipitated by metallic copper as before. A small quantity of silver is still retained in the undissolved residue of oxides of iron and copper, and this may advantageously be utilised by Augustin's process. Both these processes are largely practised.

Percy has suggested the use of sodic hyposulphite as a solvent for chloride of silver. The roasted products (of ores and salt) are washed with hot, and then with cold water, and afterwards digested in dilute hyposulphite solution, and the silver precipitated from this as sulphide by means of sulphide of sodium, sodic hyposulphite being reproduced.

Now, although it had long been known that the copper precipitate, extracted as above described by Henderson's process, contained notable quantities of the precious metals, attempts to extract them on a profitable scale were not undertaken until 1870.

Henderson and Down proposed to calcine the precipitated metals, hoping to get the chloride of silver which volatilises, condensed in a suitable apparatus, but no precipitate was condensed when experiments were made at Alderley Edge Mine, in Cheshire. The process now to be described, and known as Claudet's process, is based on the precipitation of the precious metals as iodide, and is carried out previous to the precipitation of the copper. It was introduced in the beginning of 1870, and is very successfully worked at the Widnes Metal Works, by Mr. J. Arthur Phillips.

The burnt ores, which have been roasted with salt, are lixiviated in vats, and receive eight or nine washings, with water alone or water acidified with hydrochloric acid. The first three only contain a sufficient amount of

silver to be worth working. For removing the soluble salts, hot water is employed; and, as a large amount of the salt used remains undecomposed, it acts as a solvent for the chloride of silver produced in the furnace.

The first three washings, containing 95 per cent. of the total silver dissolved, are alone treated. They are first run into wooden cisterns of capacity equal to 2,700 gallons, where they settle. The yield of silver per gallon is now ascertained by taking a measured quantity, to which are added hydrochloric acid, potassic iodide, and a solution of lead acetate. The precipitate so formed is thrown on a filter, and, after drying, is fused with a flux consisting of sodic carbonate, borax, and lampblack. The resulting argentiferous lead is passed to the cupel, and from the weight of the button of silver obtained the amount of that metal in a gallon of the liquor is estimated. In another vat the amount of soluble iodide calculated from the test, is run into the settled liquor from a graduated tank, and water added equal to one-tenth of the volume of copper liquor; the whole is now stirred and a little lime-water added, after which it is allowed to settle for forty-eight hours. This done, the supernatant liquors are assayed, run off, and the tank again filled, the precipitate which collects being washed into another vessel about once a fortnight. It consists of plumbic sulphate, argentic iodide and copper salts. The copper salts are removed by dilute hydrochloric acid and worked up by Henderson's process. To the mother liquor zinc is now added, giving its iodide for use over again, and a precipitate rich in silver and some gold. M. Claudet gives the composition of this precipitate as follows:—

	Per cent.
Silver	5·95
Gold	0·06
Lead	62·28
Copper	0·60
Zinc oxide	15·46
Ferric oxide	1·50
Lime	1·10
Sulphuric acid	7·68
Insoluble residue	1·75
Oxygen and loss	3·62
	<hr/>
Total	100·00

The first six months' experience at Widnes showed that $\frac{1}{2}$ oz. of silver and 1·5 gr. of gold were extracted at a total cost, including labour, loss of iodide, etc. from each ton of ore worked, of 8*d.* per ton, or 1*s.* 4*d.* per oz. of silver produced. Deducting from this, 6*d.* the value of 3 gr. of gold in each ounce of silver, the cost of the production becomes 10*d.* per oz. of silver, and the expense of working a ton of ore 5*d.* (Report of British Association, 1870).

Although Mr. Phillips has been so successful, other extractors have been less so, and in some works, after a trial, the process has been abandoned. One cause of the want of success is, according to Mr. Thomas Gibb, F.C.S., the presence of cuprous chloride in the liquors, and this results when the ores, badly burnt or otherwise refractory, are calcined in *hand-worked* furnaces, or when a high temperature is employed in calcination. The following tests of ores by Mr. Gibb show the great difference in the relative proportions of cupric and cuprous chlorides in calcined ores :

Cupric chloride (CuCl ₂)	6·70 per cent.	4·03 per cent.	4·25 per cent.	3·75 per cent.
Cuprous chloride (Cu ₂ Cl ₂)	Nil.	0·21 „	0·45 „	0·62 „

When present in large quantity cuprous chloride is precipitated on dilution of the liquors with water, and thus the quantity of precipitate to be worked up is increased, and in such a case, moreover, the silver is incompletely precipitated by the iodide. That the process may be worked with profit is sustained by the following facts communicated by a friend to the author. At the Runcorn Soap and Alkali Works at Runcorn, the value of the silver extracted daily was 4*l.*, using 100 tons of burnt ore per week. At an extra expense of 6*d.* per day for wages, and with a total consumption of 12 lbs. of potassic iodide, there was extracted, during 50 days, silver to the value of 200*l.* In his paper, Mr. Gibb has described a process which is employed in the stead of Claudet's by the St. Bede's Metal and Chemical Company of Newcastle. Sulphuretted hydrogen, obtained from alkali waste by means of hydrochloric acid, is diluted with air, and passed by a blowing engine through the copper liquors. But before blowing the copper in the liquors is estimated by potassic cyanide. The blowing, which lasts about twenty minutes, is continued until a sample gives 6 per cent. less copper than the first test. The precipitate is now allowed to settle, and is drained, and the copper liquors drawn off to the precipitating tanks. The precipitate is washed somewhat, and collected in an expanded Needham and Kite Filter (a filter which employs strong flannel bags with lateral pressure).

The following are average testings of liquors and precipitate :—

Solution tested	Copper per litre.	Silver, per ton of Cu.
Original solution . . .	20·1 grms.	18 oz. 0 dwt.
Desilvered solution . . .	18·8 grms.	2 oz. 19 dwt.
Precipitated by H ₂ S . . .	1·3 grm.	15 oz. 1 dwt.

These sulphides are not quite free from chlorides, and in the next operation, viz., calcination at a low temperature, copper and silver chlorides are produced with oxide and sulphate of copper. The calcined body is powdered and lixiviated, first with water, which dissolves the sulphate of copper and only a trace of silver, and subsequently with hot solution of salt to dissolve the argentic chloride. This last product always contains copper and some sulphate of lead. It is now mixed with lime-milk and the resulting precipitate well washed to free from chloride of calcium, after which it is digested in dilute sulphuric acid to separate oxide of copper and again washed. After drying it has a composition as follows:—

	Per cent.
Silver	8·77
Oxide of lead	28·66
Oxide of copper	3·75
Peroxide of iron	2·61
Lime	13·67
Sulphuric acid	31·72
Chlorine	4·70
Water	4·20
Insoluble residue	1·40
Total	99·48

Although this treatment is somewhat complicated, Mr. Gibb says it has been adopted as the cheapest, after several modifications have been attempted.

The proportion of silver recoverable from burnt ore, viz., about 1 part per 60,000, yet amounts in Tharsis and Mason's ores in value to 2s. 6d. per ton, whilst the cost of extraction by Claudet's or this process, is about 10d. per ton of ore worked, and when it is considered that 350,000 tons are produced annually, the aggregate value is not unimportant.

An important improvement has recently been introduced into the working of Mr. William Henderson's process, and the experience afforded at that gentleman's works at Irvine is of the most satisfactory nature. The improvements themselves were patented by Messrs. Chadwick and Jardine, but they have become the property of Mr. Henderson. The cuprous solutions obtained in the Henderson process, and registering from 40° to 60° T., are diluted with water to about 20° or 25° T. To the resulting solution is added a very weak solution of any soluble lead salt, but in practice the acetate is preferred. The quantity of lead acetate employed, is calculated as an equivalent upon the silver present in the solution, and a further quantity is used, equivalent to any salts of arsenic, antimony, or bismuth that may be present. As the original pyrites contain lead, in certain cases less acetate may be employed than in others. Ordinarily about half a pound of brown acetate is used per ton of ore, and in this way there is produced on stirring, a cream coloured precipitate, containing 53 per cent. of lead (as sulphate), 5 to 6 per cent. of silver, and 3 oz. of gold per ton of precipitate.

From this precipitate, after proper washing, the gold and silver may be obtained by smelting and refining in the ordinary manner. Besides the simplicity of this process in thus isolating the precious metals, it has the further advantage, it is stated, of purifying the copper liquors by causing the precipitation of arsenic and antimoniac acids, and any traces of bismuth that may be present, so that the solution in its further treatment yields a very pure copper.

Dr. Hoffmann has devised a process for utilising burnt

ores, which is said to be successful in its object. The burnt residue, by systematic washing with water at 40° C., gives liquors which are treated with salt in the proportion of one equivalent for each equivalent of sulphuric acid present. The resulting sulphate of sodium on cooling crystallises out, while the mother liquors contain zinc chloride, salt, sulphates of iron and of zinc, and a further amount of sulphate of sodium. When concentrated to 54° B. the salts are deposited, with the exception of zinc chloride which may then be isolated. In this state it has industrial applications, and is sold in Prussia at $18\frac{3}{4}$ frs. per 100 kilos., being used chiefly as a preservative for railway sleepers.

Or by treatment with lime, zinc oxide may be obtained, and from this the metal. The residue from the first operation, consisting chiefly of iron oxides, is dried in the air, during which it disintegrates, and Dr. Hoffmann finds that the pulverulent portion thus obtained is almost completely free from sulphur, so that when sifted from the larger fragments which contain sulphur, it may be used as an iron ore.

Of course the process described above, for utilising the zinc contained in pyrites, only applies to ores of a certain character. The sulphuric acid works in Germany are mainly supplied with ores derived from the mines near Meggen; these often contain as much as 6 per cent. of zinc, which, becoming sulphate in the roasting process, causes a loss of sulphur.

Before concluding this chapter, we must take some notice of the manufacture of sulphate of copper, which is also made, to some extent, from the copper obtained as described from the burnt pyrites. Some years ago this

branch of manufacture was conducted chiefly at Newcastle or in its vicinity ; now it is no longer pursued there, but is carried on principally at Macclesfield, also at Bolton-le-Moors.

The copper derived from the burnt pyrites by the wet method is calcined in an ordinary reverberatory furnace, by which operation it is converted into cupric oxide. The product is then dissolved in sulphuric acid, in cisterns lined with lead, and after time has been allowed for the liquors to settle, they are run into other tanks also lined with lead, into which strips of lead project from bars of wood laid across the vessels. To these strips and to the sides of the pans the crystals of cupric sulphate which form, attach themselves.

Considerable quantities of the product are exported to Chili and Peru, where it is used in some processes for the extraction of iodine.



CHAPTER V.

HISTORICAL SKETCH OF ALKALI MANUFACTURE.

THE manufacture which will be next described is that of 'salt-cake,' or sulphate of sodium, and as the production of this is the first stage in the manufacture of alkali, it is thought best to preface it with a historical sketch of the alkalies, their uses, etc.

The word *Lixivium*, used by the ancient Romans, is evidently derived from *Lix*, signifying a lye made with ashes. *Lixa*, another Latin term, signifies a worker in ashes, and this in itself is a proof of the antiquity of the art. Marcus Terentius Varro, the Roman general, writing in the first century, tells us that the inhabitants upon the Rhine, wanting sea-salt, used a substitute procured from wood. In the excavations of the city of Pompeii, a complete soap-boiler's shop was discovered, with soap in it, which had evidently been made from oil and alkali, and the soap, though 1,700 years had elapsed, was still perfect. Several ancient writers describe nitrum, and in the ninth century Geber the Arabian describes soda distinctly, and actually distinguishes it from potash. Pliny relates that the Germans of his day used potash for soap-making. The word 'alkali' is of Arabian origin, being derived from *kali* (a species of vegetable); the particle *al*, according to Albertus Magnus, having been

added to signify the importance of the substance over that of the plant from which it is derived¹

Mr. Rodwell, in his 'Birth of Chemistry,' tells us that nitrum was a term applied to sodic carbonate by the ancients, who used it for glass-making. In fact, glass is supposed by Pliny to have been 'first discovered by some Phœnician merchants who were returning from Egypt with a cargo of natron (carbonate of soda), and who landed on the sandy banks of the river Belus. In order to support the vessels they used for cooking their food over the fire, they used some large lumps of natron, and the fire was sufficiently strong to fuse it with the fine sand of the river. Hence resulted the first glass.'² Mr. Rodwell shows that, whatever may be the worth of the story detailed by Pliny, the ancients were proficient in glass-making, and that the composition of the Egyptian glass was nearly identical with that of our crown glass, in the manufacture of which alkali is necessarily consumed.

Soda in various forms occurs in nature very widely and abundantly. As sesquicarbonate, $2\text{Na}_2\text{O}, 3\text{CO}_2 + 3\text{Aq}$, it forms the deposits known as 'Trona' and 'Urao,' left by the drying up of soda lakes. As a mineral, in combination with carbonate of calcium, it constitutes Gay-Lussite, $\text{Na}_2\text{CO}_3 + \text{CaCO}_3 + 5\text{H}_2\text{O}$. Its occurrence as chloride (salt) will be further alluded to presently. But it was from marine plants that our early supply was derived; such plants as salsola, triglochia, salicornia, atriplex, all yield sodium carbonate on incineration. Sea plants, as a rule, however, compared with land plants, contain less soda and more potash. Sea weeds contain

¹ Parkes' 'Chemical Essays.'

² 'Birth of Chemistry,' p. 48.

or yield from 9 to 25 per cent. of ash calculated on the weed dry at 100° C., and in this ash the potash ranges from 4 to 24 per cent. and the soda from 2 to 24 per cent. The following information, as likewise some which has gone before, is taken from Richardson and Watts' 'Technology':—

100 parts ash from	salsola clavifolia	.	.	gave	45·99	per cent.	Na ₂ CO ₃
"	"	salsola soda	.	"	40·95	"	"
"	"	halmiocucum capsicum.	"	"	36·75	"	"
"	"	solsola kali	.	"	34·00	"	"
"	"	kochia sedoides	.	"	30·84	"	"
"	"	salsola brachiata	.	"	26·26	"	"

Previous to the year 1793, soda was obtained exclusively from the ashes of marine plants, the chief quantities being derived from Alicante in Spain, Sicily, Teneriffe, and the coasts of Great Britain. Russian and American potashes were also largely imported. In fact, so large had grown this importation, that during our dispute with America a considerable quantity of saltpetre was consumed in Great Britain to furnish alkali, by heating it with charcoal or other carbonaceous matter.¹ The pearlashes were prepared from potashes by calcination, whereby sulphur and carbon were burnt away, the product being employed for the nicer purposes. These potashes were prepared from the ashes of burnt wood. In the middle of the last century the Russian product was far superior to the American.

The plants described above, furnished the soda of Alicante and Carthagea, or (as it was commonly known) 'Barilla,' and were sown as seeds in the end of the year and gathered in the following September. So highly was the product valued, and the importance of the trade

¹ Parkes' 'Chemical Essays.'

regarded, that by the laws of Spain the exportation of the seed was an offence punishable by death. The plants were mowed down, sun-dried, and burnt on iron bars placed over pits 3 feet deep by 4 feet square. The ashes fell into the pit, on the floor of which they formed a semi-vitrified mass, which was allowed to cool, then broken into pieces, and in this state it formed the commercial barilla, the best qualities of which contained about 40 per cent. carbonate of soda.

'Kelp' was another commercial form of soda, and its manufacture on our shores (Wales and Scotland) was introduced from Ireland, by MacLeod in 1730, to the Highlands of Scotland. It is said that Lord Macdonald of the Isles realised 10,000*l.* a-year from his kelp shores alone. British kelp was inferior to the Spanish barilla, seeing it contained more potash, neutral salts, and carbonaceous matter. These rough alkalies were bruised and mixed with quicklime and lixiviated, to furnish the lyes used by soap-makers. They also furnished the supply for the manufacture of glass. According to Richardson and Watt's 'Technology,' kelp is still produced for making iodine and potash salts, while the mother liquors are boiled down to dryness, and yield 'kelp salts' containing from 7 to 14 per cent. of alkali, which are sold to the soda makers. In 1834 there were imported 12,000 tons of barilla; in 1850 there were imported 34,880 cwt. of barilla; in 1856 there were imported 54,608 cwt. of barilla. Scotland alone produced at one time 25,000 tons of kelp annually, so that we did not depend on the Spanish product so much as other countries.

The French Revolution of 1793 stopped the importation of soda into France, whereupon the Convention made

an appeal to the nation, and appointed a committee to discover the means of supply from native resources. Out of thirteen processes which were reported upon, that of Le Blanc was approved. Mr. Gossage has shown that the process was not an outcome of this appeal, but that Le Blanc had not only devised it previously, but had also worked it on a considerable scale. We have alluded elsewhere to the terrible privations which attended the life of this great man, and the sad story of his death. Sundry works were erected in France to carry out his process, but it was not till some years later that it was introduced into England.

At first, when introduced into England, the trade did not develope as might have been expected, because of the duties which then existed on salt, the substance from which the soda was derived by this process. The abolition of these duties in 1823 was in no small measure due to Mr. Parkes, and he ultimately received the congratulations of the Commons for his efforts. So great an effect had the abolition of the duties on the price of salt, that it rapidly fell, even in London, from 35*l.* to 2*l.* 10*s.* per ton. When once fairly introduced into England, the manufacture of soda assumed such a rapid development that in a few years it formed the most important chemical industry of the kingdom—important, as Richardson and Watts point out, on account of the capital employed, the labour employed, and the uses of the manufactured products.

This process of Le Blanc has three stages:—(1) The decomposition of common salt by sulphuric acid; (2) the decomposition of the ‘salt-cake’ so formed by chalk and carbon; and (3) the separation of the carbonated alkali

by lixiviation and its purification. These stages will be separately described, together with those improvements which have nearly all been introduced by Englishmen, and which are mainly directed, not to supersede Le Blanc's process, but to perfect it by the recovery and utilisation of once waste products. But before passing on to consider these processes, it may be of some interest to look at earlier attempts which were made to manufacture cheap soda.

Scheele, who discovered chlorine and its bleaching effects, also discovered that chloride of sodium was decomposed by oxide of lead, and previous to the introduction of Le Blanc's process, soda was manufactured in this way at Walker, by Mr. Losh, the yellow lead compound which was formed being sold as 'Turner's Patent Yellow.' Le Blanc's process is practically an improvement on the combined processes of Malherbe and Higgins. In 1778 Malherbe decomposed sulphate of sodium (it was well known at that time how to prepare this body) by reduction with charcoal. Iron was then thrown in, then more charcoal, then iron again, and so on, until sulphuretted hydrogen ceased to be evolved. The mass on lixiviation gave caustic soda. The proportions employed were:— Calcined sulphate of sodium, 100 parts; charcoal powder, 20; red-hot charcoal, 11; iron scales, 33 parts. And in this way the process was actually in work at Javelle, near Paris, before the date of the Revolution.

In 1781, Mr. Brian Higgins formed sulphate of sodium from salt and sulphuric acid, and roasted the product when dry, with one-eighth of its weight of coal in a reverberatory furnace. Metallic oxides of the heavy metals were then thrown in, and so caustic soda obtained.

It has been already mentioned that a certain quantity of sodic carbonate was manufactured in this country during our dispute with America, and how it was obtained from soda-nitre and charcoal. In 1737, Duhamel patented a process for making carbonate by reducing sulphate of soda with charcoal to sulphide, and the decomposition of the product with acetic acid. The acetate so obtained yielded carbonate of soda on ignition. These processes undoubtedly contained among them what may be called the germs of Le Blanc's process, which Mr. Losh learned on the Continent in 1802. On his return to England he worked it at Walker, with permission of the Government; and in 1823 Mr. Muspratt manufactured carbonate by this process in its entirety.

In the present day the whole of the soda manufactured is produced by the same process. It is interesting to note that in 1814 soda crystals cost 60*l.* per ton, while in 1861 the price had fallen to 4*l.* 10*s.* per ton.

In 1861 there were fifty soda works in Great Britain, producing about 3,000 tons soda ash and 2,000 tons soda crystals; 250 tons of soda bicarbonate per week, besides 400 tons of bleaching powder. The total annual value of the products exceeded two millions sterling, while 10,000 workmen were employed, exclusive of those employed in mining operations and navigation.

The prices of materials at this date were as follow:— Salt, 8*s.* per ton; sulphur from pyrites, 5*l.*; limestone, 6*s.* 8*d.*; fuel, 6*s.* per ton.¹ Mr. Cobden, by negotiating

¹ 'History of the Alkali Trade,' by Gossage, and Richardson and Watts' 'Technology.'

the commercial treaty with France, opened a new market for our products.

The figures given above, contrast strikingly with the price of soda not so many years previously. Kelp, containing on an average 30 per cent. alkali, was at the close of the last century 11*l.* per ton, a price which would render a ton of soda-ash worth 180*l.* The present price of soda is about 8*l.* per ton.

The growth of the soda manufacture in this country is well exhibited by the following figures, which we are enabled to give through the kindness of Mr. Richard Cail and Mr. Edmund K. Muspratt (hon. secretaries of the Soda Association).

Year	SALT DECOMPOSED			EXPORTS OF ALKALI	
	Lancashire Branch	Tyne Branch	Total	Quantity	Value
	Tons.	Tons.	Tons.	Cwt.	£.
1860	—	—	250,000	2,049,582	965,348
1866	194,000	157,000	351,000	2,997,479	1,613,207
1869	164,922	141,983	306,905	3,514,382	1,379,108
1874	267,987	191,769	459,756	5,010,616	2,618,034

Statistics regarding the quantities of the principal articles whose manufactures start with the decomposition of salt, we reserve until such manufactures shall have been studied.

CHAPTER VI.

MANUFACTURE OF SALT, SULPHATE OF SODIUM,
AND HYDROCHLORIC ACID.

THE manufacture of sulphate of sodium employs, as at present practised on the largest scale, sulphuric acid and salt, and having already described the sulphuric acid manufacture, we propose, in the first place, to make a few observations on salt. Salt must be regarded as one of the chief materials consumed in the alkali trade, for it is from the simple combination so familiar to us, that the soda maker manufactures his soda and his chlorine, the first of which is indispensable to the soap maker, and the second indispensable to the bleacher. It has been a familiar substance from the earliest ages, and it is connected with many proverbs and superstitions; among the Eastern nations it is an emblem of hospitality. To the human economy it is likewise essential, for by it, as a food, the stomach is enabled, by a process of decomposition and recombination of its elements, to perform its functions of digestion. It is most widely distributed in sea-water, which contains about 2·7 per cent., an amount equivalent to 4 oz. per gallon, or about a bushel in 300 to 350 gallons; and in earlier days it was from sea-water that the chief supply was derived by a process of simple concentration, when the salt crystallised out. Water dissolves 27 per cent. by weight of salt, but if it contains 27·4 per cent.

of chloride of magnesium (a body present in sea-water) it can only dissolve 2 per cent. of salt. From this fact, we see the importance attached to the concentration of sea-water, for the greater the concentration the more salt is deposited. From Richardson and Watts' 'Technology' we learn that, even so far back as the reign of Edward the Confessor salt was manufactured from the brine pits that occur in the 'wiches' of Cheshire, the beds not having been discovered until the year 1670. Again, at Wertham, brine has been worked since the days of William the Norman. One of the most remarkable brine springs in the world is that of Montiers in Sardinia, where nearly 3,000,000 lb. of salt are obtained annually from water less strong in salt than sea-water. Halle furnishes 300,000 tons per annum by the same process. In Siberia the climate is taken advantage of, by freezing the brine water and removing the ice, which leaves a mother liquor strong in salt. At one time, even on our own shores, salt was extracted from sea-water, but this method has practically passed away, although salt works exist still on the coast of Spain, France (Mediterranean shore), Italy, Sardinia, Sicily, etc. At these places, bay salt is obtained by spontaneous evaporation, when it is deposited until the density of the liquors becomes 1.262, after which, mixed salts (chloride of sodium, sulphates of magnesium, potassium, etc.) are deposited. The mother liquors are a source of bromine, and are known as 'bitterns,' and from them and the mixed salts, sulphate of sodium and potassium salts are made by Merle's modification of Balard's process. Originally, carbonate of potash was also among the products made from mixed salts.

The mean produce of a salt-work is given by Richard-

son and Watts as follows:—250 English acres, or 100 hectares of surface, produce 10,000 tons of sea-salt; 800 tons of salts (from liquors of 32° to 35° B.) giving 160 tons of Na_2SO_4 ; and 600 tons of salts (from liquors of 35° to 37.5° B.) giving 40 tons of K_2CO_3 .

Rock salt is another source, though the product often requires recrystallisation before it is ready for the market. The manufacture in Germany differs from the English proceedings, but consists, nevertheless, in spontaneous and artificial evaporation of brine liquors from springs, etc. At Salzburg the process is known as the graduation process, and is employed for liquors weak in salt. These are pumped to a height, and allowed to trickle over stacks of faggots freely exposed, but screened from the rain. A great surface evaporation is thus effected, and after this process has been repeated eight or nine times, when the density of the liquors is about 1.140, they are concentrated by heat. In the first basin or pan the deposit consists chiefly of insoluble double sulphate of sodium and calcium, $\text{Na}_2\text{Ca}(\text{SO}_4)_2$, and is known as 'schlot.' At 1.236 sp. gr. the liquor is decanted into another pan and further evaporated, when crusts of salt form and are removed from time to time.

Table salt is obtained by rapid evaporation, and is fine-grained, whereas 'fishery salt' is hard and highly crystallised, being obtained by slower evaporation. It may here be remarked that the deliquescent character of common salt is chiefly derived from the presence of chloride of magnesium, which possesses this character in an eminent degree. Most of the salt now consumed in England is obtained from the vast beds which occur in Cheshire. There are also large beds at Wieliczka in Poland, which

it is said contain enough salt to supply the world for ages, the mine being 500 miles in length, 20 miles broad, and 1,200 feet thick; it occurs in the Chalk formation. Cardona in Spain, and Belfast, likewise have beds of salt. The beds of Cheshire chiefly occur in the Magnesian Limestone. At Northwich there are two beds, 30 feet apart, being separated by clay and marl; together they possess a thickness of 60 feet, and are 300 yards broad and $1\frac{1}{2}$ mile long. The salt is purified by re-solution and re-crystallisation when necessary, and where coal is cheap, water is often let down into the mine, and the liquor is then pumped up and treated by evaporation, etc. Many improvements have of late years been introduced into the manufacture, most of them having reference to the economy in fuel, and the preservation of the pans. The total produce in the United Kingdom for 1860 amounted to 1,570,972 tons. Germany in 1846 produced 339,703 tons. Besides its enormous consumption in the alkali trade, it is extensively used in glazing stoneware goods, and for preserving and salting purposes.

It is of some interest to note here the analysis of the brine derived from the salt spring at Walker, from which the first quantities of alkali made in England were produced. The analysis was made by a Mr. G. Woods, and is stated by Mr. R. Calvert Clapham as follows:—

CONTENTS IN 1,000 GRAINS OF BRINE.

Chloride of sodium	32 grains.
Chloride of calcium	10 „
Chloride of magnesium	} 1 „
Carbonate of lime	
Carbonate of iron	
Silica	—
Total	43 grains.

It was upon this brine that the experiments of Mr. Losh and the Earl of Dundonald were first commenced, and were continued until the repeal of the duties on salt.

An idea of the amount of salt consumed may be formed from the following figures.

In 1869 there were decomposed in Great Britain no less than 326,000 tons of common salt, 142,000 tons of which were treated in the Newcastle district, and most of the rest in Lancashire. It was estimated (according to information kindly furnished by Mr. Richard Cail) that in 1874, as much as 202,000 tons of salt were decomposed in the Tyne district alone, while the amount decomposed in the Lancashire district was considerably greater. These figures will also furnish some idea of the growth of the trade during the last few years.

We will now consider the process of decomposition of salt by means of sulphuric acid. In early days this was effected in ordinary reverberatory furnaces with brick beds, the hydrochloric acid which formed (according to the equation) being allowed to escape: $2\text{NaCl} + \text{H}_2\text{SO}_4 = \text{Na}_2\text{SO}_4 + 2\text{HCl}$. The first improvement of any note in the construction of the furnace, was the introduction of leaden linings or pans in the furnace; but this gave way shortly to a plan introduced by Lee and Gamble, who employed iron pots, which were charged with from 4 to 8 cwt. of salt, and enough sulphuric acid of 130°T . at a temperature of 120°Fahr . This sort of pot was combined with two drying flats, whereon the decomposition was completed, so that three charges were in operation at one time. But even with these arrangements it will be seen that no precautions were taken to preserve the hydrochloric acid gas from dilution with the air in the furnace.

When therefore, it was desirable, and ultimately compulsory, to condense the hydrochloric acid, an operation somewhat difficult to effect in such a diluted condition, the iron pots were provided with semicircular covers, by means of which the acid was kept free from contamination with air and the products of combustion. Ultimately also, the drying flats of the reverberatory furnace, gave way to muffle furnaces, which were constructed with the same objects in view. In such cases 16 cwt. of salt constituted a charge with 1,800 lb. or 123·5 gallons of sulphuric acid of sp. gr. 1·45 and at 120° Fahr. The mixture was raked about, covered with the hood and fired, when about one hour was sufficient to expel all the hydrochloric acid. Richardson and Watt, from whose work these figures are taken, state that two such furnaces will turn out about ten charges a day, being equivalent to nearly 19 tons of 'salt-cake' production from 16 tons of salt. 100 parts of salt give 62 parts of dry hydrochloric acid, and about 116 parts of salt-cake, against 121·5 parts Na_2SO_4 required by theory. As these furnaces are now constructed, the cover to the pot has two doors, through one of which the charge is introduced, whilst by means of the other it is transferred to the 'roaster furnace.' These 'pots' are about 9 feet in diameter, and made of cast iron 2 to 7 inches thick, the cover being of a similar construction with a maximum depth of 1 foot. The fire is made to pass over the cover and under the pot. The 'muffle' is adjacent to the pot, and constitutes a chamber of about 30 feet long by 9 feet wide, heated by fire from one end which traverses a space left between the muffle and its outer roof, and which extends also beneath and along the bed of the furnace. Half a ton of salt is a convenient

and ordinary charge—although the charge varies from 5 to 18 cwt. salt—and in about one a half hour two-thirds of the hydrochloric acid are expelled from the ‘pot.’ On the bed of the muffle it loses the other third by decomposition of the bisulphate with undecomposed salt.

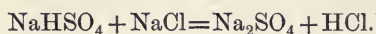

The respective gases are kept separate, and are technically known as ‘pot’ and ‘roaster’ gas.

Within the last year another form of furnace for producing salt-cake has been devised and patented by Messrs. Cammack and Walker. In principle it resembles an ordinary sausage-machine. The salt is charged into a hopper at one extremity of the furnace, which is tubular in construction, and thence into the furnace by means of a continuous spiral screw which travels along the entire length of the apparatus. The progress therefore of the salt into the furnace is very gradual and uniform, while the sulphuric acid is charged upon it by means of an automatic arrangement which supplies it at the desired speed, in a thin stream. Thus, all the hydrochloric acid generated is of one strength, and readily condensable in the towers; meanwhile, as the mass travels through the furnace it is gradually converted, so that it issues at the other extremity as finished salt-cake. Expectations are high in regard to this plant, but so far as experiments have been conducted at the works of Messrs. Golding, Davis, and Co., of Widnes, they have not been of a thoroughly decisive character so far as we can learn. We are informed that the ‘turn-out’ or capability of a cylinder 21 feet long amounts to about 50 tons of salt-cake at 95 per cent. per week. There is a rumour to the effect that

a danger is anticipated from crusting of the material on the cylinder sides.

It is impossible, however, to speak in any decided terms in regard to this new furnace and its working results.

Among other new forms of furnaces recently patented, there is one by Mr. James Mactear, which promises good results.

The amount of 'salt-cake' (sulphate of sodium) made in a pot varies from 50 to 75 tons, while the total amount a pot turns out varies from 1,000 to 2,000 tons. Through the courtesy of Messrs. Daglish and Co. we are enabled to give plan and elevations of decomposing pot

FIG. 10.

SECTION THRO' I.K

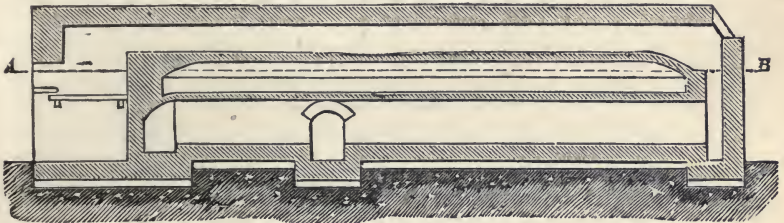
Scale $\frac{1}{8}$ inch to the foot.

and roaster as employed in many works. (Figures 10, 11, and 12). Of late years many manufacturers have resorted to Siemens' gas method of heating these furnaces. The gas furnished in the coal roasters is allowed to deposit its tar and ammoniacal liquor in metal or earthenware condensers, which are constructed in the form of large tubes or pipes of 2 to 3 feet in diameter. The supply of gas mixed with the air necessary for its combustion is regulated by a valve, and passes under the pot, and then over the furnace.

In a plan patented by Deacon and Robinson, the heat

for the pot was generated in an ordinary cupola supplied with a blast and an ashpit, situated away from, but in

FIG. 11.

SECTION THRO' I. K

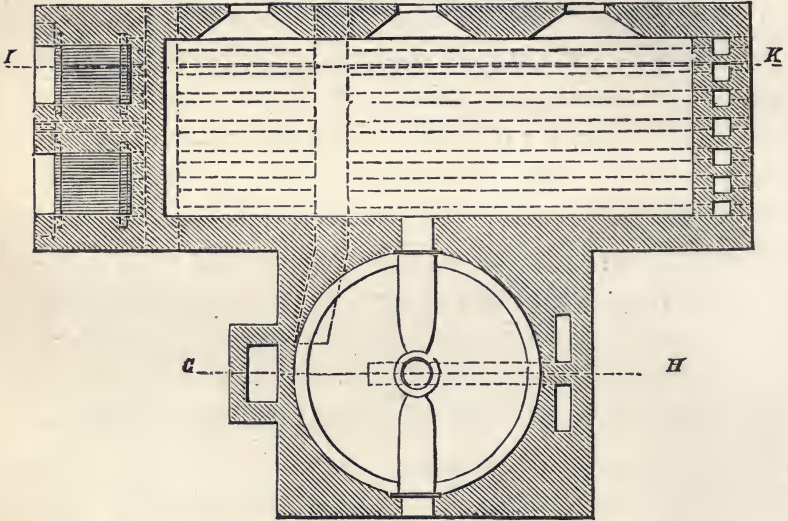

Scale $\frac{1}{4}$ inch to the foot.

proximity to, the furnace. As already stated, before the bleaching industry assumed its present importance, and

FIG. 12.

SECTION THRO' G. H

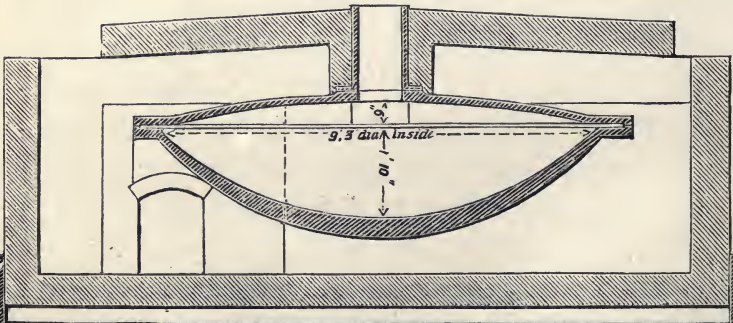

Scale $\frac{1}{8}$ inch to the foot.

when therefore, the hydrochloric acid generated had little or no value, it was allowed to escape, and desolated the country around for miles, destroying vegetable life of all kinds.

But when its employment as a source of chlorine to be used in the manufacture of bleaching powder increased, various means were proposed and used to condense and utilise it. Where it proved a curse to the neighbourhood, it was condensed by causing it to traverse long chambers or towers packed with limestone moistened with water, when chloride of calcium formed and was discharged, being valueless. Kuhlmann passed it through a series of stoneware vessels through which a stream of water ran in an opposite direction to the gas current; the water towards the end of the series being mixed with witherite or native barium carbonate, produced chloride of barium, which was used for making permanent white (sulphate of barium). In France the acid was absorbed by sets of carboys containing water, with imperfect results. But the time was drawing near, when, by Act of Parliament, perfect condensation was rendered compulsory, whereby, indeed, new resources of wealth were opened to manufacturers who were hitherto content to throw away this now valuable product. Gossage had already introduced a much more perfect system of condensation, by means of towers packed with lumps of coke, over which a stream of water was disseminated falling, and into one of these towers the gas entered at the bottom and rose to the top, while that which remained unabsorbed passed into a second tower, where the condensation was completed. The draught for causing the gases to pass through these columns was supplied by the chimney of

the works, but Mr. Bell patented the use of a steam-jet for aiding the draught, through its action as an aspirator. Mr. Clapham, however, effected the object in a better way, by pumping up the weak acid from the second tower to absorb fresh gas in the first one. Sometimes flint is used instead of coke. Mr. Gossage's plan has developed and extended, and works so well that since the Alkali Act of 1863, which renders the condensation of 95 per cent. of the hydrochloric acid compulsory, 99 per cent. condensation has been common. These condensers are generally constructed of Yorkshire flagstones, and supplied with a cistern at the top, and a well at the base for collecting the acid which is of a strong yellow colour, and averages 35° T.

The sulphate of sodium produced as described, averages from 96 to 97 per cent., and when good it readily crumbles by pressure between the fingers. When carelessly made it is hard, lumpy, and yields inferior results in its subsequent employments. But, perfect as the process is, there is a considerable loss of sodium, which amounts on the average from 2—2·5 per cent. as undecomposed salt, and an additional ·5 to 1·0 per cent. mechanical loss. To refine salt-cake it is dissolved in water, and treated with a slight addition of lime to precipitate any iron that may be present, in the form of oxide. The settled liquor is next evaporated to dryness, and the product furnaced, and in this state it is ready for the market. The hydrochloric acid gas is conducted from the furnaces to the condensers by earthenware pipes covered with tar and clay, to prevent cracking by the rain or other cooling influences. In certain works, glass pipes are now used: these have a diameter of about 15 inches, and are

loosely packed so as to allow of expansion by the hot gases which they convey. They are so constructed that they fit one into the other, and in this way the trouble of having the pipes luted together is rendered unnecessary. These glass pipes are protected by a wooden shade.

Notwithstanding the improvements that have been effected in the construction of the 'decomposer,' much expense and inconvenience are often caused by stoppage of work through breakage of the pans, and hence many attempts have been made to improve them. Thus in 1860, Mr. R. Calvert Clapham had some pans made of fire-clay, which were used at Walker, and found to work very well, except that they were difficult to heat. Recently the same gentleman, in a paper read before the Newcastle Chemical Society, has described a new form of furnace, patented by Messrs. W. Jones and J. Walsh, by the use of which the decomposition of salt is completed in one furnace. Several such furnaces are already in work; they are constructed in the form of a metal dish, composed of six segments or plates of metal $2\frac{1}{2}$ inches thick, resting on solid brickwork. 'The diameter is 15 feet, and the charge of salt is about 12 tons each twenty-four hours; so that a furnace of this capacity will turn out about 80 tons of sulphate of soda in six days. The batch is kept in constant motion by means of two cross metal arms, worked from a centre shaft, to which are fixed paddles and rakes, and the whole mass is much more completely mixed than in a hand-worked furnace, while the sulphate produced is of a very fine and uniform character.' Although at present the charge is introduced and withdrawn by hand, Mr. Goodman hopes to perfect a plan for doing this by machinery.

The advantages claimed for the use of this new furnace may be stated as follow : (1) A more regular means of working, and exemption from breakages. (2) A saving in wages, one man only being required for each shift for charging and working the furnace. (3) A saving of fuel. In the ordinary method 9 cwt. of coal (equal to $5\frac{1}{2}$ cwt. of coke) are consumed per ton of sulphate turned out, whereas by this method only 3 cwt. coke are used per ton of salt-cake made. (4) A calculated saving in sulphuric acid, amounting to about 2 per cent. (5) The hydrochloric acid is generated regularly and of an uniform strength throughout, which allows of its perfect condensation in one tower, giving acid, which, when hot, marks 26° to 28° T. Finally, there appeared good reason to expect that each furnace would turn out 100 tons of sulphate of sodium weekly, but more recent experiences have not fulfilled, we believe, the expectations formed in regard to this plant.

From what has gone before, it will be evident that the maximum amount of sulphuric acid that is manufactured is employed as a means of decomposing salt, with the production of a material to be afterwards used (when not for glass-making) for obtaining caustic and carbonated soda. Therefore the saving that would be effected by the introduction of a process (supposing it to be effectual) for making ' salt-cake ' in one operation, and thus abolishing the necessity for costly acid chambers, is enormous, and at once evident. Of the many methods suggested, previous to Hargreaves' (of which more anon), the most plausible was that of Longmaid, which though not entirely new, being based on a well-known reaction, was greatly developed and the method of working im-

proved by him. So late as 1861, the process was in use at several works, but it has never been in general or even extensive, use, on account of a loss of sulphurous acid which is experienced. This process consists in roasting pyrites and salt in a reverberatory furnace, sulphate of sodium, ferric oxide and chlorine being the products: $4 \text{FeS}_2 + 16 \text{NaCl} + 19\text{O}_2 = 2 \text{Fe}_2\text{O}_3 + 8 \text{Na}_2\text{SO}_4 + 8 \text{Cl}_2$ (Miller). From the residue, the sulphate of sodium is extracted by lixiviation, and the residual ore worked for copper, silver, and iron. Some chlorine is evolved likewise, but it is too dilute to make good 'bleach' to which purpose Longmaid proposed to direct it, after washing out the hydrochloric acid which itself was contaminated with volatile ferric chloride.

During the last few years, Mr. Hargreaves, of Widnes, has worked out a process for the direct manufacture of sulphate of sodium, which consists in exposing common salt, moulded into bricks or other forms with a little water, to the action of sulphurous acid, air and steam, at a temperature of 800° to 900° Fahr. The following reaction first sets in at about 700° Fahr., $2\text{NaCl} + \text{SO}_2 + \text{O} + \text{H}_2\text{O} = \text{Na}_2\text{SO}_4 + 2\text{HCl}$. The salt is placed in the chambers, and finished sulphate is drawn out. Mr. Hargreaves has stated that the loss of sulphurous acid experienced is much less than in the old process, and that a part of the hydrochloric acid is 'burned' into chlorine and water. But this last statement as to the chlorine is of no value, because much chlorine could not be formed, and none could permanently exist in the presence of sulphurous acid, whilst if any existed it would simply be an inconvenience when in small quantity. The gases from the pyrites burners constitute the sulphurous acid

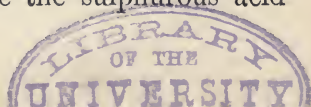

employed, and these being at a red heat, and the action itself being a source of heat 'the fuel required to make a ton of sulphate is not more than a third part of that required by the sulphuric-acid process of making salt-cake.' One most important feature in the process is that it dispenses with the use of nitrate of sodium, which is costly, and rock-salt can be employed. Further, as no very high temperatures are employed, the wear and tear of the apparatus is quite inappreciable. Some time since (March 1874), we were informed that two manufacturers were building plant for the production of 100 tons of salt-cake per week each, and that a third plant was about to be commenced. Moreover, Mr. Hargreaves has for some time prepared considerable quantities of salt-cake by his method. At any rate it is of very high importance, and bids fair to attain commercial success.

This statement is supported by the fact that quite recently two patents have been secured relative to this process. In one, Mr. Arthur McDougall proposes to use superheated steam, by which means he claims to complete the reaction in less time. He also claims to facilitate the reaction by maintaining the salt in motion by suitable means, and thus avoids the moulding of the salt into bricks. In the other, Mr. William Hunt proposes to erect the chambers wherein the decomposition is effected, immediately over the pyrites burners, so that the heat from the hot gases issuing therefrom is utilised, as far as practicable, to heat the contents of the chamber itself. Robb, in 1853, had proposed to pass sulphurous acid, air and steam over salt and oxide of iron; and even more, in 1857 Brooman passed these gases over salt alone,

contained in hot flues. But it was left, as we have seen, for Mr. Hargreaves to develop the process as a manufacture.

Phillips and Kuhlmann, in 1832, proposed to make sulphurous acid into sulphuric acid by passing it, along with hot air, over finely divided platinum; and in 1855, Schmiersahl and Bouck passed a mixture of sulphurous acid, air and steam through horizontal pipes of clay or iron, filled with asbestos, pumice or other porous material, and strongly heated in a furnace. But this last method was probably an outgrowth from Wöhler's researches ('Ann. Chem. Pharm.,' lxxx. 255), to which we have already adverted, and which demonstrated the facility with which the oxides of copper, iron, and chromium, at a low red heat, transform sulphurous acid and oxygen into sulphuric acid. But, as previously stated, the attempts that were made at Oker on a large scale proved unsatisfactory. Hargreaves' process, then, combines the principles involved in those processes, just briefly sketched, and goes a step further, and presents to the sulphuric acid at the moment of formation common salt whereupon to react. This, no doubt, aids moreover the formation of the sulphuric acid.

Having now given an outline of Hargreaves' process, and of certain older proposals, which seem to lead naturally to it, we purpose considering more in detail the precise method of procedure. In doing this, we are greatly helped by the drawings kindly placed at our disposal by Mr. Hargreaves, and which we reproduce here (figs. 13 and 14). Originally, Mr. Hargreaves moulded the salt into bricks with water, these when dry, were broken into pieces about $1\frac{1}{2}$ inch in diameter.

But, more recently, Mr. J. C. Stevenson has invented an apparatus for moulding the salt into pieces of suitable size and shape (circular), which are then dried by causing them to traverse the length of an oven like those used by biscuit bakers. The advantages of using salt prepared in this form consist in the saving of labour by the use of machinery; avoiding the production of dust in the breaking machine; saving fuel, and ensuring regularity of action by uniformity of the pieces of salt in size and shape. Mr. Hargreaves prefers to use 'coal salt,' that is to say, salt obtained by surface evaporation of brine liquors by the direct action of flame, as, by these means, salt is obtained which binds better and preserves a porosity. And in a recent paper he states that he has received much assistance through Pohl's process of making salt, which, by a considerable reduction in the fuel, reduces the cost of the salt.

The sulphurous acid gas used in the process is of course derived from the roasting of pyrites, but, inasmuch as the success of the whole process depends on the amount of fuel used, Mr. Hargreaves does not use the ordinary form of burner, but one which avoids the loss of heat experienced generally through radiation from the burner front. This is effected by encasing the door in a non-conducting lining, and avoiding the exposure of surfaces of iron to the heat of the burning pyrites, by substituting common brickwork, which forms an excellent non-conducting material.

Mr. Hargreaves describes the plan of working as follows :—

'The prepared salt is placed in iron cylinders where it lies without further manipulation till converted into



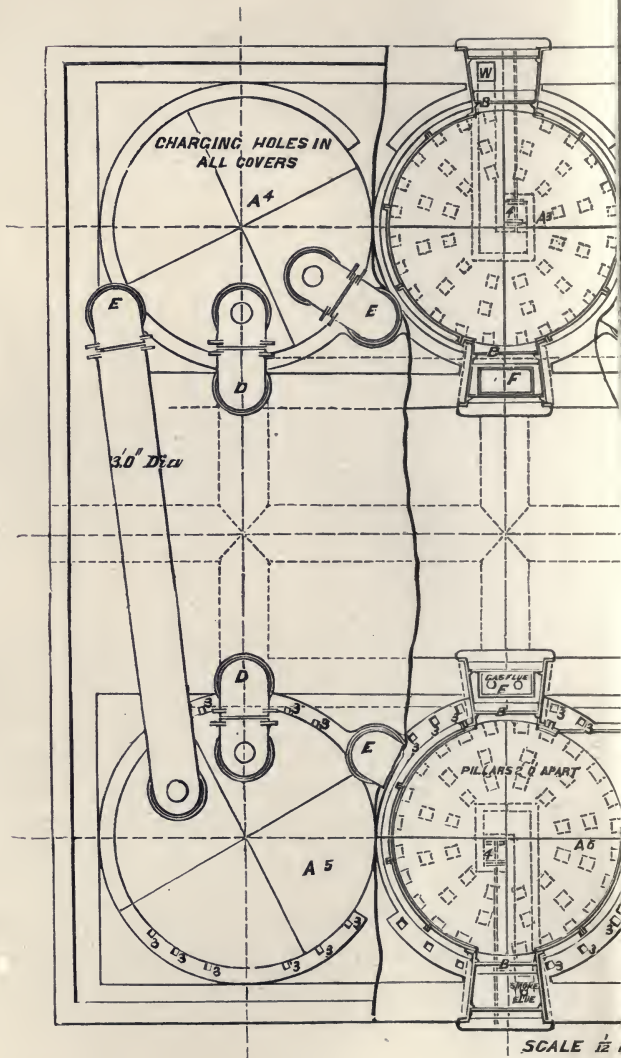

PLANT USED IN HARGREAVES'

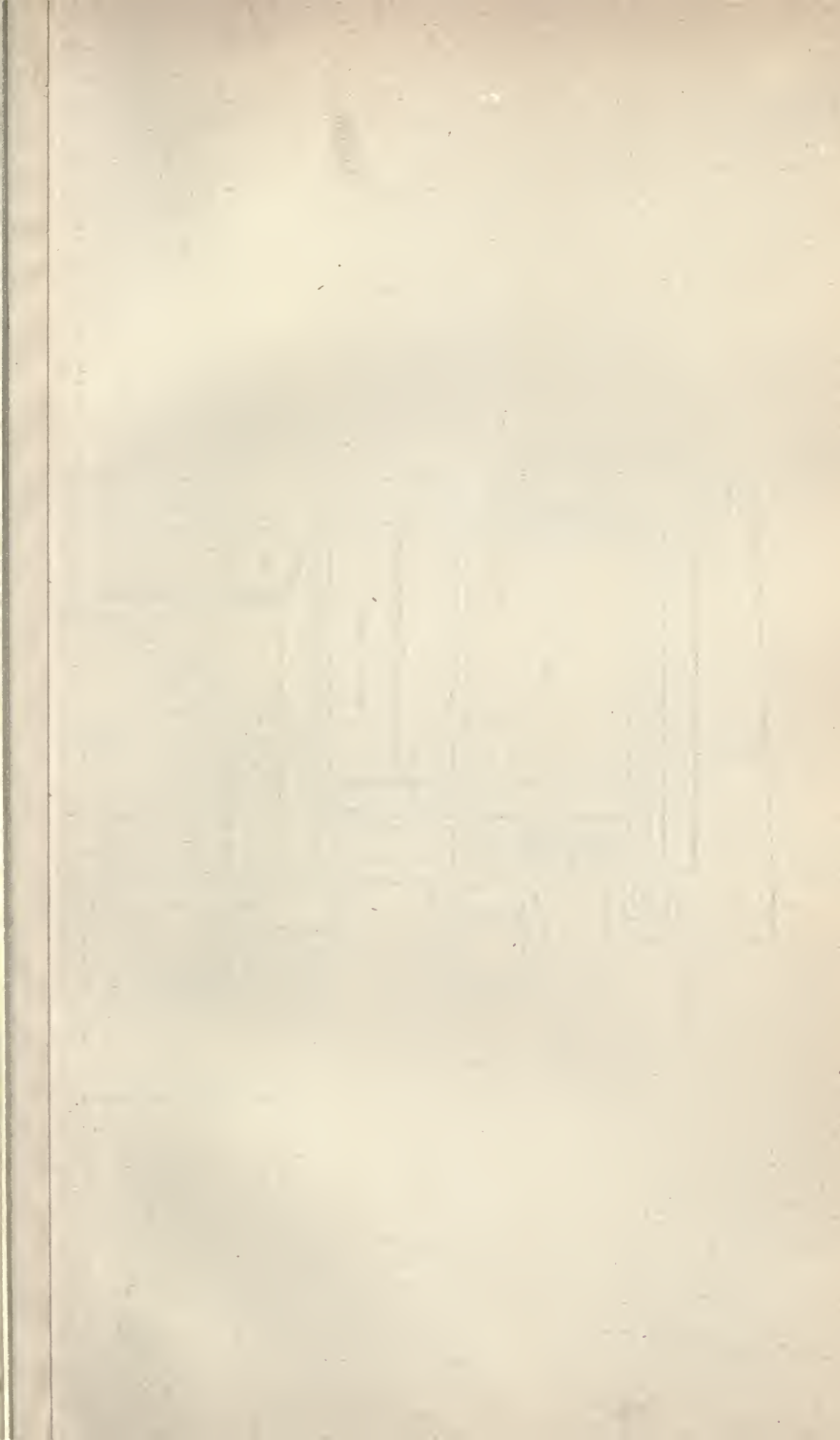

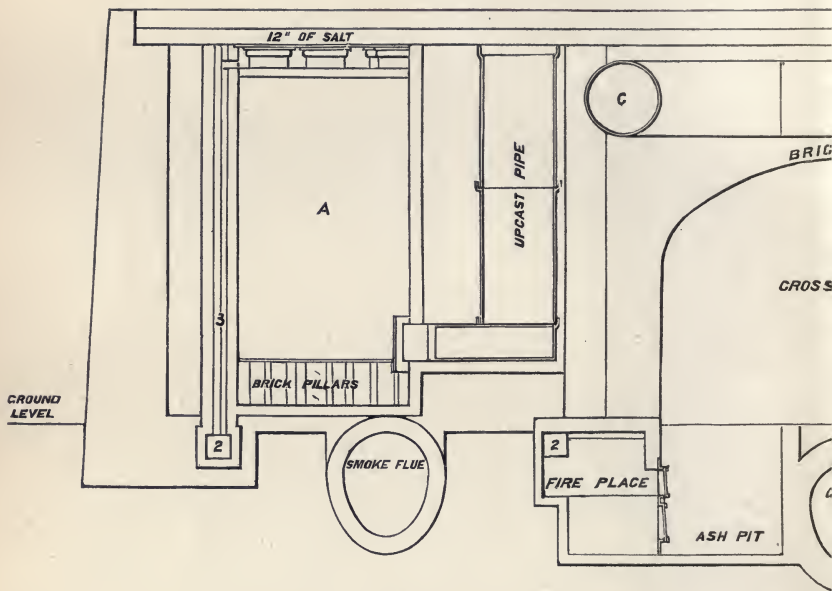

HARGREAVES' PLANT

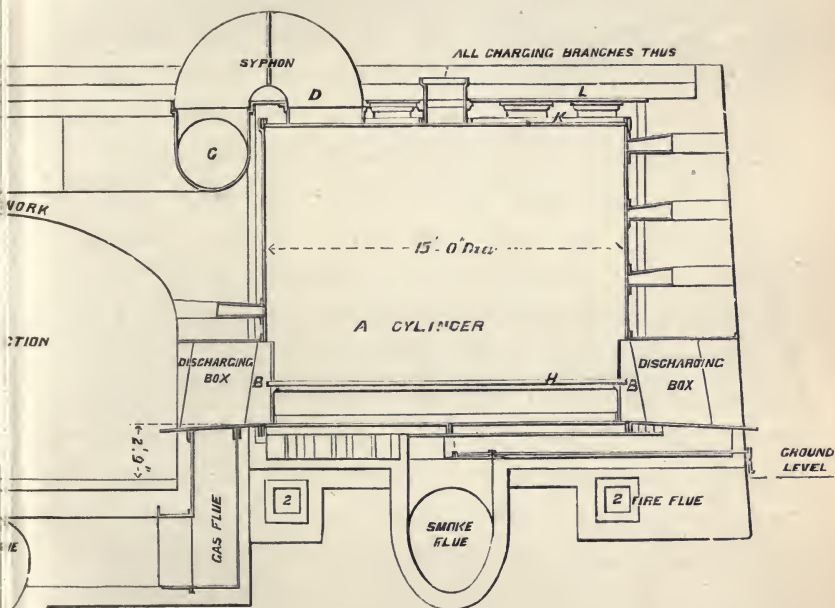

MAKING SALT-CAKE.

sulphate. The minimum number of cylinders that we advise is eight in a series, and the greater the number the more regular is the reaction, and the smaller the quantity of fuel required per ton of sulphate manufactured. The series of cylinders is so arranged that each in its turn becomes the first, intermediate, and last. The SO_2 is first admitted into the cylinder whose contents are most nearly converted into sulphate, and the spent gases pass out from that which was last charged with salt, after passing through a succession of cylinders containing less and less sulphate.*

'The apparatus here shown consists of eight cylinders of 15 feet diameter and 12 feet high, disposed in two rows and marked A1, A2, etc. They are provided with doors, B, for withdrawing the sulphate. The ground space between the two rows of cylinders is covered by an arch which is covered with ashes. Along the sides of the two rows of cylinders, and over the abutment of the arch, are two iron flues, C, which conduct the SO_2 from the burners to the cylinders. The flues are protected from loss of heat by the arch below and a bulk of ashes on the outside, the other side being against the heated cylinder. A layer of ashes is also laid over the flues. Ashes form the most efficient non-conducting material readily obtainable, their rate of conduction being only about half that of common bricks, and being also costless and of small weight for a given bulk. Each sulphurous acid flue has four syphons, D, connecting them with each of the cylinders. The cylinders are connected with each other by the circulating syphons, E. When at work the whole of the SO_2 syphons, except the one connected with the 'finishing' cylinder (i.e. the cylinder whose contents

are most nearly converted into sulphate), are closed, and the SO_2 is allowed to flow into this cylinder. Suppose A3 to be the finishing cylinder and A2 the exit cylinder, the SO_2 syphon between C and A3 is open and the circulating syphon between A3 and A2 closed, so as to prevent the SO_2 from passing direct to the exit cylinder without going through the whole series. The gas passes in succession through A3, 4, 5, 6, 7, 8, 1 and 2 leaving the cylinders by an opening in the bottom of the drawing doorway, F, whence it passes into the flue, G, and is withdrawn by exhausting apparatus. The salt or sulphate lies upon moveable grids, H, which are supported by tripods. These tripods fall readily on striking out small cramps which keep the feet near together, and leave the grids unsupported when the sulphate is withdrawn. When the sulphate in A3 is finished the gas is admitted into A4 from the SO_2 flue, the circulating syphon between A4 and A3 is closed. After withdrawing the sulphate and filling A3 with salt, the circulating syphon between A2 and A3 is opened and A3 is made the exit cylinder. The short pipes, J, serve as charging holes to supply the charge of salt. One of these has an annular space around it, to admit the products of combustion into the inside of the cylinder, if at any time it is desirable to heat the salt before turning the gases into it. It also allows any gases from the inside of the cylinder to pass directly into the chimney flue, and prevent them from annoying the workmen when withdrawing the charge.

‘The gas from the pyrites kilns is too concentrated to be allowed to pass direct into the cylinders containing raw salt, for then the action becomes so violent as to fuse it into a hard cohesive mass. This is avoided by getting

up the temperature as soon as possible, and allowing the salt to get covered with a coating of sulphate while at the exit end of the series, where only about one-tenth of the original quantity of SO_2 is contained in the gas. The covering of sulphate increases in thickness as the cylinder gets nearer the inlet.'

'The cylinders are heated by fire-places (1). The hot gases pass through a horizontal flue (2) and ascend narrow vertical flues; these flues are only 5 inches square in section, the object being to reduce the heat-absorbing surface where the products of combustion are very hot; the flues, however, are amply large enough to carry away all the products of combustion. The fire-places are furnished with close-fitting doors, so that when the fires are not needed, both the fire-places and ash-pits may be secured against admission of air, and at the same time the damper (4) is closed to stop draught to the chimney. After leaving the vertical flues the smoke passes into a space 10 inches deep between the cylinder cover and an upper covering plate, circulating round the charging holes and over the cylinder cover; the smoke then passes down the side of the cylinder and beneath it, when it passes the damper to the chimney.'

The amount of fuel consumed at Messrs. Boyd and Alexander's is as follows, viz. :—

Heating cylinders	4	cwt.	}	Per ton of sulphate of sodium.
Preparing salt	3	"		
Steam, say	$\frac{3}{4}$	"		
Total	$7\frac{3}{4}$	cwt.		

The following is an analysis by Mr. W. Plunkett of an average sample of a cargo shipped by Messrs. Boyd and Alexander :—

Sulphate of soda	99·24
Chloride of sodium	·08
Free acid and moisture	·20
Oxide of iron and insoluble	·48
	<hr/>
Total	100·00

Mr. Hargreaves, by dint of very difficult and prolonged studies, has at last succeeded in placing the process on such a basis as to form a powerful rival to the old method of working. In short, there can be no doubt that if in the future the process should meet with that success which is expected of it, it will amount to a complete revolution in the alkali trade of this country.

Of many other processes that may have been proposed, or used to a small extent, for the manufacture of sulphate of sodium, the following are the only ones it is desirable to mention here. M. Ramon de Luna has shown that when crystallised magnesium sulphate (Epsom salts), which abounds in certain Spanish mines, and which is also a manufactured product from Greek stone ($MgCO_3$) and sulphuric acid, is heated to redness with half its weight of salt, hydrochloric acid is evolved, and magnesia and sulphate of sodium are left. Indeed, by this process, more than 12,000 kilos. of very pure sulphate of sodium have been made. The MgO can of course be used over again by dissolving it in sulphuric acid. In 1871 Mr. Henry Deacon secured by patent a process for producing sulphate of sodium simultaneously with chlorine, by the passage of sulphuric anhydride (SO_3) mixed with air or oxygen, over or through chloride of sodium at an elevated temperature; the following reaction first occurs: $2NaCl + 2SO_3 = Na_2SO_4 + SO_2 + Cl_2$. Thus, as will be seen, sulphurous acid is produced along with the chlorine,

and of course the latter cannot be used for the production of bleaching powder until after the removal of the sulphurous acid. Mr. Deacon proposes to effect this removal, by causing the sulphurous anhydride to become sulphuric anhydride by uniting it with oxygen of the air present, through the catalytic action (so called) of sulphate of copper, or other substances. Then this sulphuric anhydride is passed over other chloride of sodium, thus giving more sulphate of sodium and half the original quantity of sulphurous acid. The apparatus is so arranged, therefore, that the gases pass alternately over sodic chloride and the catalytic substance; and by repetition of these proceedings Mr. Deacon claims to convert all the sulphurous acid into sulphate of sodium, with the liberation of the chlorine from the salt in a state of dilution with the nitrogen of the air, etc. In a somewhat later patent Mr. Deacon describes a process very much like the foregoing, but distinct in several particulars. It consists in passing sulphurous acid, air, and aqueous vapour at an elevated temperature over heated salt, giving sulphate of sodium and hydrochloric acid thus: $2\text{NaCl} + \text{SO}_2 + \text{H}_2\text{O} + \text{O} = \text{Na}_2\text{SO}_4 + 2\text{HCl}$. The hydrochloric acid gas and the excess of air are then exposed to the influence of sulphate of copper or other substance at a high temperature, giving dilute chlorine to be utilised by any existing processes for the production of bleaching powder ($2\text{HCl} + \text{O} = \text{H}_2\text{O} + \text{Cl}_2$).

Glauber's salts is the name for sulphate of sodium which has been further refined by recrystallisation, and this manufacture is carried on at several works in Lancashire; but the substance so obtained is not sold in any

great quantity. Of course, when sulphate of sodium is obtained by the methods heretofore described, it is in an anhydrous state; but on recrystallisation it combines with water of crystallisation, and has the formula $\text{Na}_2\text{SO}_4, 10\text{H}_2\text{O}$.

CHAPTER VII.

MANUFACTURE OF CARBONATE AND BICARBONATE OF SODIUM.

THERE are several varieties of commercial sodium carbonate, which are known respectively as soda ash, white alkali, and soda crystals, and which differ in form and their degree of purity. But they are all produced from 'black ash,' which is crude sodic carbonate, made by furnacing sodium sulphate together with chalk or limestone or lime, and coal. The proportions in which these several substances are mixed are almost identical with those first used by Le Blanc; and although each manufacturer has his peculiar idea of the best proportions, it may safely be said that those usually employed are as follow:—Salt-cake (sulphate of sodium), 3 cwt.; chalk or lime, 3 cwt.; coal (slack), 1.5 to 2 cwt. These figures represent the actual weights employed where, as is the more usual practice, 'twenty-four stone balls' are made. This expression signifies that twenty-four stone salt-cake has been actually employed in making each 'ball'; but in some works 'twenty-stone balls' are made, or, in other words, while the proportions observed in the mixing are the same as those above given, the quantities start from 2.5 cwt. of salt-cake. When caustic soda constitutes the desired product, the proportions used are different to those given, and certain other conditions are also observed; but these will be pointed out fully in our next chapter.

Before proceeding to describe the operations which

are undertaken to produce carbonate of sodium from such mixtures, we will quote a few analyses of salt-cake, limestone, and slack ashes made by Mr. George E. Davis.

Analyses of Salt-cake.

Constituents	A	B	C
Insoluble in water . . .	0·112	0·073	0·042
Free sulphuric acid . . .	0·955	1·820	0·022
Calcium sulphate . . .	1·139	1·148	1·046
Iron persulphate . . .	0·682	0·588	0·322
Sodium chloride . . .	2·632	0·234	0·744
Sodium sulphate . . .	94·393	96·137	97·824
Moisture	0·087	—	—
	100·00	100·00	100·00

Analyses of Lump Limestone.

Constituents	Buxton.	Minera.	Ruthin.
Organic matter . . .	traces	traces	traces
Silica	0·106	0·442	0·398
Alumina	0·123	0·145	0·135
Ferrous carbonate . . .	0·187	0·348	0·252
Calcium carbonate . . .	99·372	98·298	98·370
Magnesium „ . . .	0·116	0·756	0·756
Manganese „ . . .	0·013	0·022	0·026
Calcium phosphate . . .	trace	trace	trace
	99·917	100·011	99·937

Analyses of Ashes of Slack.

Constituents	A	B
Silica	49·36	48·74
Alumina	26·86	22·79
Iron peroxide	14·00	18·76
Lime	7·07	5·43
Magnesia	0·48	0·99
Sulphuric acid (SO ₃)	1·12	2·74
Phosphoric acid (P ₂ O ₅)	0·11	0·05
	99·00	99·50

As regards the sulphate of sodium, it may be said that since the introduction of improved methods of manufacture, such as those described in our last chapter, it is easily obtained of even greater purity than that indicated by the above analyses.

The limestones as supplied to the works are often mixed up with a quantity of clay or sand, which matters increase the silica and alumina introduced into the processes to be described, and act prejudicially by causing a loss of sodium as insoluble salts. Mixing slack yields from 7 to 16 per cent. ash, and from the above analyses it will be seen how much silica and alumina is introduced in this way; therefore, the lower the percentage of ash the better fitted is the coal for its purpose. The percentage of carbon present in the various varieties of slack varies from 70 to 88 per cent. more or less. But to continue the study of the process of soda manufacture. The salt-cake, limestone, and slack are worked by a spade into a mixture which should be free from large pieces, and in this state it is charged into the furnace.

The reverberatory furnace used, is provided with two beds, one of which is at a lower level than the other. The one nearest the fire is the lower one, while the charge is introduced on the furthest one from the fire, through an iron door. Thus two charges, each of about 7 cwt., are in work at a time, one heating, and one fluxing on the hottest bed. Towards the end of the operation much gas (chiefly carbonic oxide) is evolved in the form of 'candles,' which burn with a yellowish-green flame. At this stage tranquil fusion sets in, and the operation is completed. It is therefore raked out, after a little brisk working, into 'bogies,' which are square iron boxes about

9 inches deep, set on wheels. When cold the product is known as 'ball-soda,' and each ball weighs about 5 cwt., twelve to sixteen being produced in twelve hours.

These balls consist of carbonate of sodium and caustic soda, sulphide and carbonate of calcium, unburned coal, etc. They contain from 22 to 26 per cent. alkali, reckoned as Na_2O ; from 0.5 to 1.0 per cent. Na_2SO_4 and 0.6 to 1.0 per cent. Na_2S when properly made. It is easy to see by their colour when they are 'overlimed,' and in such a case the balls, by losing much of their porosity, yields less alkali in the vats. By 'green balls' is meant under-roasted balls containing an excess of undecomposed sulphate, and 'burnt balls' signifies over-roasted balls, which are generally pregnant with sulphides of sodium. Analyses of black ash necessarily differ widely, as it is not a pure chemical individual; moreover, the analyses of the different samples of the same ball often differ considerably.

The elaborate analyses of black ash or ball soda stated on p. 103, were given by Mr. G. E. Davis in a paper on the manufacture of white caustic soda read before the Society for the Promotion of Scientific Industry, May 25, 1875.

In these analyses Mr. Davis has calculated the matters into soluble and insoluble constituents, so that it may be readily seen what dissolves and what remains insoluble during the subsequent process of lixiviation.

The general results which are there indicated, fairly express those obtained by the author also, during an investigation of the chemistry of black ash making, extending over many months. It will be seen from these analyses how difficult must be the methods employed.

The analytical methods ordinarily employed in the analysis of black ash serve only to yield results which are valuable, so far as they admit of comparison among themselves, while, in many instances, the actual results obtained are not to be trusted. We hope that Mr. G. E. Davis will soon find time to elaborate and publish his new methods of analysis.

Constituents	A	B	C
Sodium carbonate . . .	28·144	31·807	28·336
„ oxide	5·860	5·614	3·844
„ chloride	2·808	2·574	3·101
„ sulphate	0·192	0·191	3·037
„ sulphite	0·151	0·072	none
„ hyposulphite	0·189	0·853	0·126
„ sulphide	0·358	0·163	6·645
„ aluminate	0·344	0·752	0·923
„ silicate	1·026	0·914	0·758
„ cyanide	0·186	0·043	0·422
„ sulphocyanide	0·074	0·021	0·077
Calcium sulphide	29·504	29·744	33·245
„ carbonate	12·657	9·272	6·087
„ oxide	10·048	9·488	3·465
Iron sulphide	0·554	0·774	1·355
Alumina	0·172	1·042	0·624
Silica	1·095	0·923	0·973
Magnesia	0·266	0·322	0·146
Soda	0·344	0·546	0·577
Carbon	4·263	4·483	4·958
Sand	1·237	0·875	0·842
	99·472	99·479	99·646
Soluble iron sulphide			·105

All that has gone before, relates to hand-worked furnaces. These are subject to great wear and tear, which destructive processes display themselves equally on the tools employed by the workmen for raking and stirring the mixture. There is also experienced a large absorption of the fused mass into the bed of the fur-



nace, and in this way the furnace is often destroyed by actually fusing through into the fireplace where the heat is the greatest. To avoid this difficulty, air-passages are sometimes constructed between the fireplace and the first bed of the furnace. Moreover, these furnaces have to be stopped at definite periods in order that the flues may be cleaned out. The loss caused by stoppage might, perhaps, be avoided by constructing the furnace with two flues ultimately converging and provided with swing dampers, so that the one flue might be used while the other is being cleaned out.

We must now direct our attention to a form of furnace which was first introduced in 1853. Already, in 1848, Mr. W. W. Patinson had devised a furnace in which the balls were worked and expelled by machinery, but it was short lived on account of the great wear and tear incidental to the use of such high temperatures. The first form of revolving furnace worked very indifferently; the balls turned out by it were not sufficiently porous, and therefore would not lixiviate well. But shortly afterwards Messrs. Stephenson and Williamson, of the Jarrow Chemical Works, effected an improvement in its construction, which again led to its use. Since then, many other improvements have been introduced, among others by Messrs. Robert Dalglish and Co., to whose courtesy we are again indebted for the engravings of a revolving furnace (figs. 15, 16, and 17). This furnace is worked with Siemens' patent gas arrangement, and on consulting the references attached to the figures, the methods of heating and working will be evident to the reader. The furnace itself is cylindrical, and is lined with fire-bricks, ridges of which project one above the other, and act as

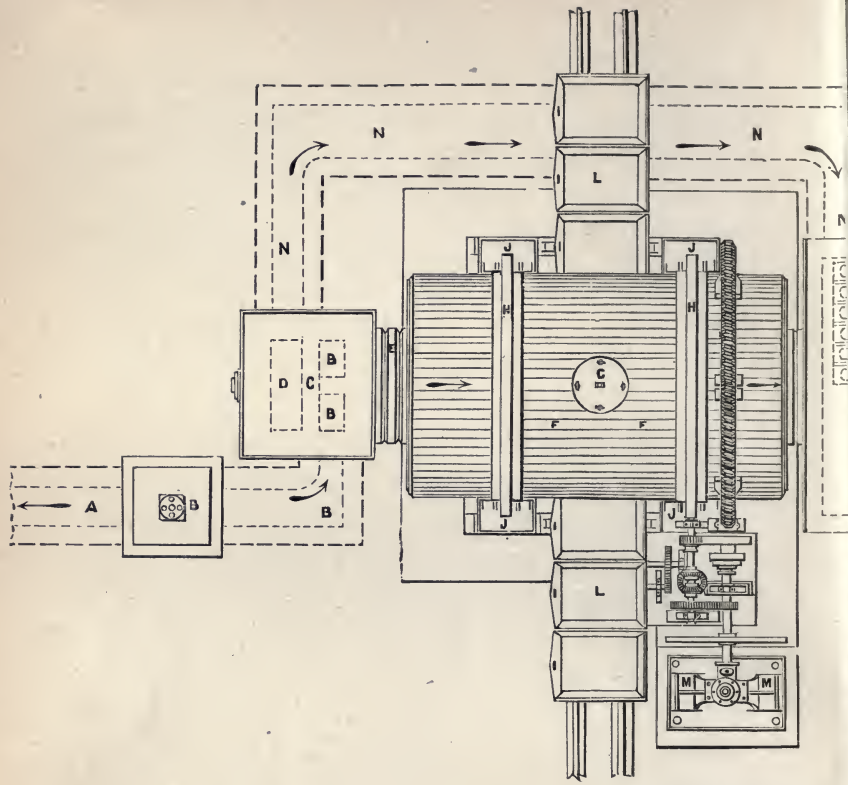

REVOLVING FURNACE FOR

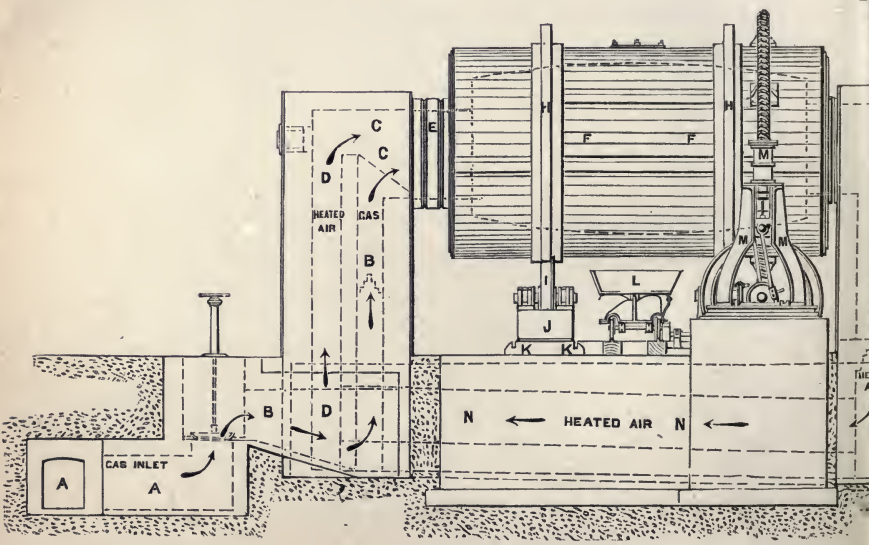

REVOLVING FURNACE FOR M

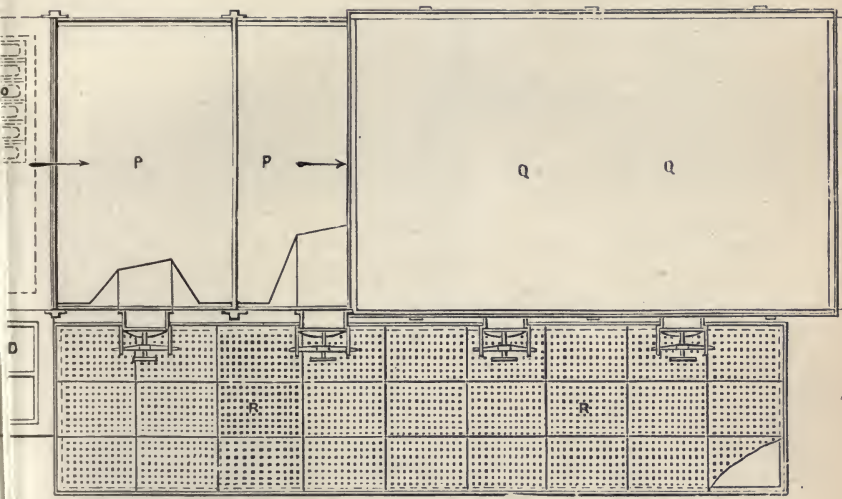

MAKING BLACK ASH (PLAN).

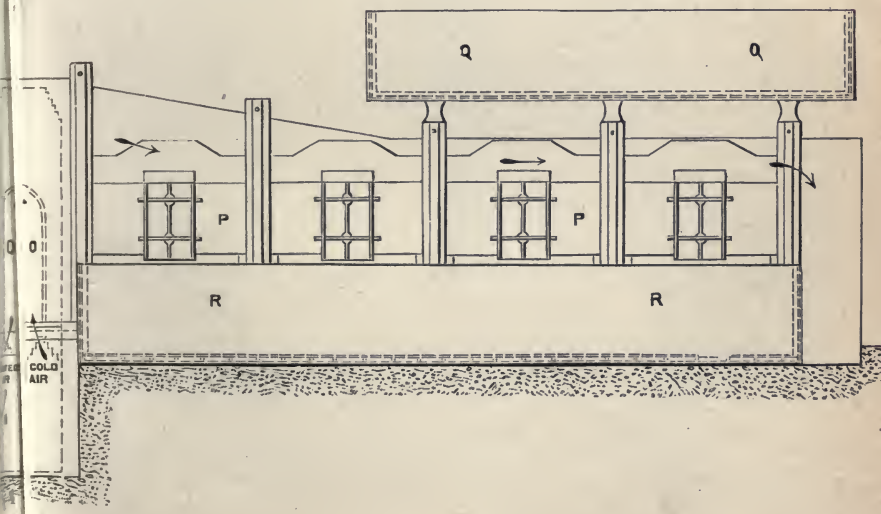

MAKING BLACK ASH (ELEVATION).

Fig. 17.

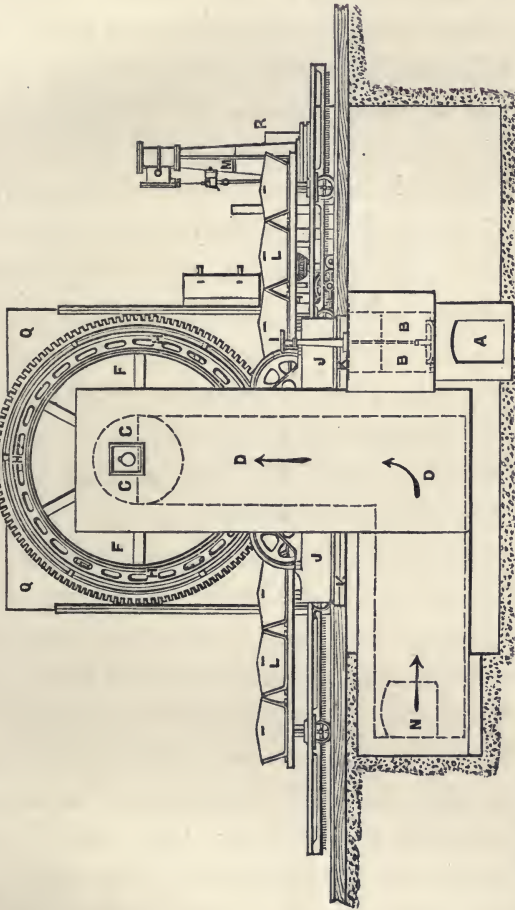

The following references relate to all the figures 15, 16 and 17:—

- A A Gas flue.
- B B Gas inlet for regulating supply of gas } Siemens' patent arrangement.
- C C Combustion chamber
- D D Air inlet.
- E E Ring for allowance of expansion in cylinder.
- F F Revolving furnace, lined inside with firebricks and blocks.
- G G Charging hole when on top side and discharging hole when on bottom side.
- H H Friction rings which work upon friction rollers (I, J).
- I I Steel-tired friction rollers.
- J J Foundation bearers sitting upon strong iron tie-plates (K, K).

- K K Foundation plates.
- L L Waggons for receiving black ash and driven by engine (M, M).
- M M High-pressure engine for driving the black ash cylinder and waggons, and being varied in speed by the gearing.
- N N Air-fue for supplying heated air to combustion chamber and heated by the waste heat after passing through the furnace (E, F).
- O O Cast-iron air heater.
- P P Salting-down pan over which the waste heat passes from the revolving furnace.
- Q Q Vat for supplying salting-down pan.
- R R Drainer pan.

stirrers and mixers. The flame passes into, and around the inside of the furnace, and thence over the liquors requiring concentration, contained in adjacent pans.

The charge usually employed, consists of 30 cwt. salt-cake, 32 cwt. of limestone, and 20 or 21 cwt. of slack. These are introduced through a hopper, which serves also the purpose of a discharging mouth. Such a charge takes about two hours to work off, and yields ten balls of 3 cwt. each.

The rate at which the furnace revolves at first, is very slow—about one revolution per 20 minutes—but this can be increased at will, by increasing the speed of the engine, to five or six revolutions per minute, which represents the maximum speed. These furnaces are about 10 feet in diameter by 15 feet long, but some are now made 12 feet in diameter and 18 feet long. A furnace 10 feet by 15 feet is capable of converting about 170 tons of sulphate of sodium in six days.

The advantages gained by the use of revolving furnaces may be stated thus: (1.) Uniform heating of the charge, and so prevention of loss of sodium by volatilisation. (2.) Less labour is required and more work done in a given time than can be accomplished in an ordinary reverberatory furnace. (3.) The use of tools is rendered unnecessary, and the danger of absorption of soda into the bed of the furnace is obviated. One disadvantage of the use of these revolving furnaces is, that they turn out balls which are somewhat dense, and therefore difficult to thoroughly lixiviate.

This led to the carbonate of lime and part of the coal being first charged and heated for some time, so as to produce a quantity of caustic lime, the other materials

being added subsequently. In this method the obtained results are better. The plan of charging a mixture of caustic lime and carbonate of lime with the sulphate of soda and coal, has also been tried, but gave balls bad in quality and difficult to dissolve. Mr. James Mactear, aware of, and used to these difficulties encountered in making ball soda in revolving furnaces, has patented improvements, which are in work most successfully, both at St. Rollox, Glasgow, and in the Lancashire district.

In the working of these improvements, a mixture of sulphate of soda with coal, and a quantity of carbonate of lime barely in excess of the chemical equivalent, is charged at one time into the revolving furnace, and the heating operation is allowed to proceed until the reaction is nearly complete, which is recognisable by the fluxing of the materials and other signs. At this point, a small quantity, say 10 per cent., of crushed caustic lime is added, and then, as soon as this added caustic lime is thoroughly mixed with the other materials, the entire charge is withdrawn. In this way the disadvantage of having caustic lime present during the reaction is avoided, whilst the intermixture of a suitable small proportion of caustic lime at, or near the end, has the effect of rendering the resulting balls easily soluble, and well conditioned for the subsequent operations. The quantity of caustic lime to be thus added 'will vary accordingly as the manufacturer wishes to have more or less of the soda in a caustic state, 3 to 4 per cent. having in practice given good results in cases in which a minimum proportion of caustic soda was desired.'

Among the advantages attending these improvements,

the following are enumerated by Mr. Mactear: (1.) The proportion of carbonate of lime being diminished, a much increased quantity of sulphate of soda may be decomposed in a furnace of a given size; in fact, the productive power of these furnaces is thus increased by 50 per cent. (2.) The time occupied in finishing each charge being reduced, an increased number of charges can in most cases be worked in a given time. (3.) There is a great saving of coal and carbonate of lime. (4.) A diminished proportion of waste is left on lixiviating, and consequently less soda is lost with the waste. (5.) A diminished proportion of caustic soda and sulphides are found in the liquors, the total caustic lime being alterable at pleasure.'

Now we shall see that Kestner has demonstrated that in making black ash the loss of soda as insoluble salts in waste, increases with the increase of proportion of carbonate of lime used, and he recommends, therefore, the use of the least possible excess. Mr. Mactear's improvements are based upon these facts, and by their use he produces soda at a cheaper rate with less loss. At the same time, by introducing a percentage of lime near the end of the operation, the porosity of the ball is not sacrificed, and so perfect lixiviation is ensured.

In December, 1876, nineteen revolvers were working according to this improved process, and Mr. Mactear anticipated that by the following January twenty more would be working. This fact is not surprising in face of the splendid results obtained by the use of these improvements.

The chemical reactions that occur in the furnace have been made the subject of much discussion and experiment. We shall content ourselves here, with stating Mr. Gossage's

views, which are those most generally adopted, and which are expressed in the following equation :—



Perhaps this is the right time to note that Blythe and Kopp patented and worked a balling process, in which peroxide of iron was used instead of lime or chalk. The sulphide of iron so obtained was burned to furnish fresh sulphurous acid for the chambers, whilst the residual ferric oxide was used over and over again.

We must next consider the losses of soda that are experienced in the 'balling operation' as conducted in hand-worked furnaces. Dr. C. R. A. Wright estimates the losses as follows :—

Undecomposed sodic sulphate . . .	3.49 per cent.
Insoluble sodic compounds . . .	5.44 „
Vaporisation of sodic compounds. . .	1.14 „
	<hr/>
	10.07 „

These results were based on experiments conducted during the manufacture of 5,000 tons soda ash.

M. A. Scheurer-Kestner claims to have proved that in the furnacing operation, no soda-salts are reduced to metallic sodium, and therefore no loss by volatilisation of the metal occurs; and that the greater part of the loss is due to the formation of insoluble sodic salts, which are retained in the waste, a loss which is never less than 5 per cent., and often greater. He endeavours to show that this loss increases proportionately with the excess of limestone or chalk employed, inasmuch as this excess of lime becomes hydrated in the vats, and reacting upon the Na_2CO_3 forms insoluble salts. He gives the following table :—

Limestone used for 100 Na_2SO_4 .	Na retained by 100 waste.
98.0	0.59
102.0	0.86
107.5	1.27
111.0	1.30

Whilst, therefore, an excess of lime is generally used to prevent the formation of polysulphide of calcium, Kestner recommends the use of no excess, or the least possible, to avoid loss of soda as insoluble salts.

In a paper already quoted from, by Mr. Mactear, the loss of soda in Leblanc's process is given, and he finds that the greatest loss occurs as insoluble sodic salts plus soluble salts in the waste, which amounts to 5 or 7 per cent. of the total soda.

The Lixiviation of the Black Ash constitutes the second stage in the manufacture of sodic carbonate. The present system of effecting this operation is mainly due to the efforts of Clement Desormes and Mr. Shanks. Clement Desormes' arrangement embodied the descent of the liquor contained in the top vat of a series arranged one above the other, to those successively below it, and worked the black ash in the opposite direction. That is to say, the black ash, being first introduced into the lowermost vat, was transferred from vat to vat by means of baskets worked with handles, until it reached the highest vat, by which time it was fully exhausted. But it was reserved for Shanks to take advantage of the superior specific gravity of the liquid obtained by lixiviation over that of water. This he did by recognition of the principle that a given column of a liquid of a given specific gravity, corresponds with a given greater column of a liquid of a less specific gravity; and therefore if a series of vessels be arranged in a row, and contain liquids of the varying

specific gravities, which gradually decrease from first to last, a flow is effected from the beginning to the end, just the same as if the vessels were ranged one above the other.

It is on these principles that the vats in most common use are now worked. These vats are either 6 feet square and 6 feet deep, or, as now often constructed, one whole series are 54 feet long, 11 feet wide, and 5 feet deep.

The black ash is broken up into big lumps, and these are then charged in the vats which are provided with false bottoms on which the black ash rests. Water is then supplied to them at a temperature of about 120° Fahr., but the temperature of the water used varies from 90° to 140° Fahr., and well it might, when the temperature in many works is simply guessed at, by feeling the pipe conveying it with the hand. The water is contained in a cistern, where it is raised to the required temperature by blowing steam into it. In the tanks or vats, the black ash swells, disintegrates, and yields up its soluble salts, forming a more or less greenish-blue liquid, which is transferred from one vat to the next, where it becomes stronger by taking up alkali from another lot of black ash, and so on, until it leaves the final vat at a specific gravity of about 1.3.

The residue remaining in the vats after perfect extraction, so far as is practicable, contains all the sulphur from the sulphate of sodium used to make the black ash, and a certain amount of soda, varying from 0.3 to 1 per cent. Na_2O . The water used for lixiviation should not exceed about 120° Fahr., otherwise the calcic sulphide is decomposed into sulph-hydrate, which is soluble, and hydrate of lime, and the sulph-hydrate immediately reacts on

the sodic carbonate, giving sodic sulphide and calcic carbonate.

The following summary of the action of water upon black-balls is taken from Watts's Dictionary, and is information derived from Kolb:—(1.) A given quantity of crude soda yields very different proportions of caustic soda and sulphide of sodium, according to the quantity and temperature of the water and the *time* allowed for digestion. (2.) The degree of causticity of the resulting solution is not sensibly affected by the quantity of water, but increases with the time of digestion and temperature. (3.) The quantity of sulphide of sodium increases with the quantity of water, and more particularly with time and temperature. (4.) The decrease in the amount of sodic carbonate not only corresponds to the amount of caustic soda formed, but is also affected by the variation in the amount of sodic sulphide formed. Hence, it would appear that the sodic sulphide is formed at the expense of the carbonate. (5.) The amounts of sulphide and caustic soda formed bear no definite relation one to the other. (6.) The presence of lime or caustic soda prevents the action of sodic carbonate upon calcic sulphide, with the production of calcic carbonate and sodic sulphide.

The average time required to work off a vat is forty-eight hours. The liquors obtained by lixiviation contain between 10 and 11 lbs. of real soda per cubic foot, or about 13·5 per cent. by weight. A vat of about 6 feet square conveniently takes twelve balls, and gives liquors of about the following composition, expressed in grammes per litre. The analyses are those of Mr. G. E. Davis.

Analyses of vat liquor	50° Tw. at 99° Fahr.	50. 5° Tw. at 90° Fahr.
Iron sulphide	0.074	0.042
Sodium sulphide	4.485	3.822
" sulphite	1.323	0.979
" hyposulphite	1.580	1.774
" sulphate	12.707	14.258
" chloride	19.597	23.412
" silicate	5.961	3.774
" aluminate	3.371	4.218
" ferrocyanide	0.133	0.416
" sulphocyanide	0.211	0.196
" phosphate	traces	traces
" fluoride		
" carbonate	209.500	204.326
" hydrate	44.800	52.740

It will be seen that these vat liquors contain small quantities of sulphocyanides and ferrocyanides; they cannot therefore be utilised for furnishing sodic carbonate direct, on account of the yellow colour that adheres to the sodic carbonate in such a case, and which is caused by the presence of iron.

The destruction of ferrocyanide is said to have been successfully accomplished by Mr. Williamson of the Jarrow Chemical Works, by heating the liquors under pressure to a temperature of 310° Fahr.

Production of Soda Ash.—Where an inferior soda ash is wanted, the vat liquors are boiled down, and the residue calcined in furnaces about 18 feet long and 9 feet wide, and lined internally with fire-bricks. The waste heat from the balling furnaces is generally employed in evaporation, and in some works the flame is made to pass into a flue running along the top of the furnaces themselves, and thence downwards into the main flue, whilst on the top of the furnaces are placed pans, the flue being

constructed as a passage left between the furnace and the pans; but this method, though very effectual, introduces the evil of a great pressure on the furnace itself, and sometimes involves the manufacturer, should his furnace or pans crack or give way, in a mess. Sometimes a system of pans is employed, in the last of which the carbonate of soda deposits, and is sorted out, the mother-liquor being evaporated to dryness. Mr. Gossage, among his multifarious improvements, aids the evaporation by drawing hot air through the liquors. The product is soda ash, containing from 65 to 73 per cent. carbonate, and from 13 to 24 per cent. caustic soda, 4 to 7 per cent. sulphate of soda, and 2 to 6 per cent. of salt, besides small amounts of other substances.

If required in a purer state (and for the manufacture of plate glass this is necessary) the soda ash is mixed with about its own bulk of sawdust (sometimes small coal is used), and heated in a reverberatory or so-called 'calker furnace,' where it is repeatedly worked by paddles at a temperature of about 600° to 700° Fahr. (about the melting point of lead). Meanwhile the sulphur and carbon are burnt off, and the caustic soda becomes carbonated. The process is known as 'calking,' and lasts from 2 to 2½ hours.

For obtaining what is known as white alkali, the soda-ash salts are re-dissolved by water in vats, aided by steam. A ton of water dissolves a ton of the ash, giving a liquor of 54° T., which is allowed to settle, and is then evaporated in iron pans, fired with coke. These pans are 20 to 30 feet long, 7 wide, and 2 deep. The ash removed is called 'white alkali,' and contains 77 to 84 per cent. Na_2CO_3 , and from traces to 5 per cent. caustic

hydrate; 2 to 10 per cent. of Na_2SO_4 , and 3 to 7 per cent. NaCl . Ward employed Greek stone (Mg CO_3) along with the sawdust in carbonating, and he states that in this way, a purer and a stronger white alkali is got. Shanks treated the black ash with carbonic acid, while Wilson patented the use of soda bicarbonate, which he mixed with the liquors in the ordinary reverberatory furnaces, stirring till dry.

To obviate the presence of sodic sulphide and sulphide of iron in black-ash liquors, Gossage oxidised the Na_2S by atmospheric oxidation in towers filled with coke. With such purified liquors the excess of caustic soda must be carbonated by carbonic acid, before boiling down the liquor drawn off from the precipitated ferric sulphide ensuing on the oxidation of the Na_2S to Na_2SO_4 . Gossage further isolated the ferrocyanide present in the liquors by first crystallising out the excess of carbonate, precipitating what remained as bicarbonate, or else causticising it, and crystallising out the potassic ferrocyanide from the mother-liquors, after which it was refined and sold. Mr. Deacon prefers to purify these liquors by means of ferric oxide, which gives ferrous sulphide and caustic soda.

To obtain the product known as 'soda crystals,' the 'soda ash' or 'white alkali' is dissolved in nearly boiling water kept heated by steam in iron pans, until specific gravity = 1.225, enough being dissolved in one operation to give two, three, or four tons of crystals. The solution is then filtered through bags of unbleached calico, or allowed to settle for about 12 hours, then concentrated in boilers over free fires until specific gravity = 1.30; it is then run into settlers, and a small quantity of lime or bleaching powder, or both, added. Thus the liquid is

clarified, after which it is allowed to settle again till the temperature is 92° Fahr. when it is run into crystallising coolers of cast iron, the surface of the liquid being covered with bars of wood or iron, to which the crystals attach themselves. After five or ten days the mother-liquor is run off and boiled down, giving a white alkali of weak strength. The crystals are drained, dried, and packed. Sometimes the product is again purified by recrystallisation.

Dr. Wright, in his paper above alluded to, gives the following as loss of soda during and after lixiviation of black ash:—Soluble alkali left in vat waste, 3.16 per cent.; oxidation of sulphide, inappreciable; leakage and loss during white-ash process—6.56 per cent.; total 9.72.

Bicarbonate of Soda is, as will be shown, the product of the 'ammonia process,' to be described in a future chapter. It is, however, also manufactured by moistening the crushed soda crystals (of carbonate) with water, and exposing them on cloths to the depth of two or three inches, in stone or wooden boxes, to a current of gaseous carbonic anhydride; the water of crystallisation is separated during the process, and there is simultaneously experienced a great rise of temperature. The carbonic acid is generated either by the action of hydrochloric acid upon limestone, or by burning coke or coal in a kiln, and washing the resulting products of combustion.

Messrs. Kurtz and Co., of St. Helen's, make this material largely, by packing soda crystals in what may be called iron boxes, where they are exposed to a current of carbonic acid gas, made by the action of hydrochloric acid upon limestone. The product of this operation goes to the drying house, which is packed with

shelves, and on the top ones the substance is first placed, and removed gradually to the bottom shelves at such a rate that when the product reaches the lowest shelves it is quite dry. It is then powdered in a mill and packed. It is largely used for the preparation of baking powders, etc.

We are enabled, through the kindness of Mr. Edmund K. Muspratt and Mr. Richard Cail, to whom we are indebted for many important statistics having reference to the alkali trade, to give here some figures illustrative of the growing importance of this branch of the trade.

In 1799 there were produced on the Tyne 10 tons of soda crystals, which were sold at 50*l.* per ton. In 1809, 66 tons were produced, which sold at 62*l.* to 71*l.* per ton. In 1866 there were produced in the Tyne district 86,000 tons of soda crystals, selling at 5*l.* 10*s.* per ton; 74,000 tons of soda ash or alkali, selling at 11*l.* per ton; and 11,000 tons bicarbonate of sodium, selling at 18*l.* per ton. In the same year, in the Lancashire district there were produced 24,978 tons soda crystals; 87,314 tons soda ash and refined alkali; and 6,457 tons of bicarbonate of sodium.

CHAPTER VIII.

MANUFACTURE OF CAUSTIC SODA.

WE have seen in chapter vii. that after the carbonate of sodium contained in the vat liquors has been crystallised out, there remains a mother-liquor known technically as 'red liquor.' This contains much caustic soda, and the credit is generally given to Gossage for having, in 1851 or 1853, suggested the manufacture of solid caustic soda from these liquors by sufficient concentration. Hitherto, for most purposes, these liquors were carbonated, and a further quantity of soda ash obtained from them. But Deacon has recently called attention to the following extract from the specification of a patent granted to Mr. George Brown, of the firm of Messrs. Charles Tennant and Co., of St. Rollox, and dated February 20, 1845:—'Red liquor . . . is brought into a metal pan, and is evaporated to about the consistency of tar; the proper quantity of nitrate of soda is then added, and heat applied to expel the remaining water and flux the mass,' etc. This would seem to indicate that even before Mr. Gossage made caustic soda in this way it had been made by Tennant and Co., while still less credit therefore belongs to those various other firms which have laid claim to the invention. In short, it was one of those progressive inventions to which no one individual can lay

sole claim, but in which many have a share. Amongst these latter, besides those enumerated, come Mr. McBryde, Mr. Lee, Mr. Gamble, and Mr. Deacon.

In 1855 Stott patented a process for removing the sulphides contained in vat liquors by means of the oxides of iron, manganese, or zinc, and this same process has been since patented many times by different persons. Bakewell was the first (1857) to patent the method of packing the caustic soda in sheet-iron drums, and his method is still employed. Previous to this, it was usual to pour it out upon iron plates, after which it was broken up and packed in wooden casks. In 1858 the method of causticising with lime and oxidation of the sulphides by air was patented by four gentlemen named Thomas. For carrying this causticising operation into effect, it is necessary to dilute the liquors, and in 1859 Mr. Dale resorted to the concentration of the caustic liquors in the boilers used for generating steam. This method is even now employed in some works, but it is not an unmixed good, owing to the crusts which form and deposit in a hard state on the boilers.

Up to 1860 most of the caustic soda produced was of the character known as 'cream soda,' that is, soda which has been concentrated in the state of liquor until on cooling it has set in a hard state; the concentration is not continued to fusion. But, in November 1860, Ralston patented the following improvements:—'If it is desired to produce a hydrate of great strength (it is done by), evaporating and separating the foreign salts, but in place of keeping the heat low as hitherto, the evaporation is continued, and the heat raised until the iron separates as oxide of iron, and until the oxide is precipitated to

the bottom of the vessel, the clear alkali is then separated from the iron.' But how it was possible for Ralston to patent this method does not appear clear, for Deacon has pointed out that his firm made their first batch of caustic soda in this way on September 17, 1857. It is further known that Gamble and Son, of St. Helen's, had been even before Deacon in this respect, while Mr. McBryde also made caustic soda in 1859.

For some of the foregoing observations we are indebted to Mr. George E. Davis, from whose excellent article on the manufacture of white caustic soda we have previously quoted. Before proceeding to describe the mode of manufacture as at present conducted, we give a few figures illustrative of the growth of this manufacture. In 1867 there were produced on the Tyne no less than 3,720 tons of caustic soda, while during 1866 there were made in the Lancashire district 11,213 tons of caustic soda. Since then the manufacture has greatly developed, so that many works now turn out from 100 to 250 tons weekly.

The process itself, starts with the production of black ash or ball soda which has been already described. But whereas it is an object to keep down the lime as low as possible when carbonate of sodium is to be made, this is not so necessary in the case of caustic soda. Moreover, the lime mud from the causticiser may be used for mixing with the salt-cake and slack instead of so much limestone. The mixing proportions may, therefore, be either as represented in the one or other column following:—

	A		B
Salt-cake	2·5 cwt.	2·5 cwt.
Buxton limestone	2·75 "	1·5 "
Lime mud	none	2·5 "
Slack	1·5 cwt.	1·5 "

The lixiviation of the black ash has also been described in the last chapter; and, in fact, the analyses of the vat liquors therein given really relate to those obtained from black ash so made as destined to furnish caustic soda.

We here give two other analyses by Mr. G. E. Davis, who has expressed the results in grms. per litre:—

Constituents	50° Tw. At 90° Fahr.	50½° Tw. At 90° Fahr.
Iron sulphide	0·074	0·042
Sodium sulphide	4·485	3·822
" sulphite	1·323	0·979
" hyposulphite	1·580	1·774
" sulphate	12·707	14·258
" chloride	19·597	23·412
" silicate	5·961	3·774
" aluminate	3·371	4·218
" ferrocyanide	0·133	0·416
" sulphocyanide	0·211	0·196
" phosphate	traces	traces
" fluoride	traces	traces
" carbonate	209·500	204·326
" hydrate	44·800	52·740
CaO, MnO and MgO	traces	traces
	313·742	320·857

We now come to the operation of causticising, which it is impossible to carry out upon strong liquors. The vat liquors are therefore reduced in strength from 50° – 60° Tw. (1·27 – 1·28 sp. gr.) to 22° Tw. (sp. gr. 1·10). Some manufacturers reduce them to 14° or 16° Tw., but this is quite unnecessary, and adds only to the cost of production, for all the water added at this stage has to be again evaporated. After settling, the liquors are run into the ‘causticiser,’ or ‘operation pan,’ an apparatus of varying size, and, like the ‘filter,’ to be presently

described, often constructed out of an old boiler. When specially made, the operation pan is $25 \times 6 \times 6$ feet, and is provided with a circled bottom so as to facilitate agitation, and an agitator worked by a bracket engine. In addition to these, there are steam-pipes for heating the charge to 100° C., a valve for running off the mud, and a drop syphon for decanting the clear liquor which is eventually obtained.

In some works no agitator is employed, but a current of air is blown in along with the steam and this acts effectually as an agitating cause, while it also serves the useful purpose of oxidising any sulphides that may be present. In a few works, litharge (oxide of lead) is added to remove the sulphides, but the advisability of its use is, to say the best for it, questionable. When used, there are required about fifty pounds per ton of 60 per cent. caustic soda.

It may be said that twelve good balls give sufficient vat liquor for one operation in the causticiser, and from this quantity there should be produced nearly one ton of finished caustic soda, so that salt-cake gives about 50 per cent. caustic soda.

The liquor contained in the causticiser is heated to boiling by means of steam, and supplied with sufficient freshly-burnt lime as free as possible from alumina and silica. This is generally supplied through an iron cage which retains stones and big lumps; meanwhile, the agitation and steaming are continued and carried on until a little of the filtered solution gives no effervescence on the addition of dilute acid. To an experienced workman the conditions of boil, colour, and time, are indications, moreover, of the approach of the 'finish.' Of course, the prin-

cipal reaction that occurs in the causticiser consists in the removal of the carbonic acid from the soda, thus— $\text{Na}_2\text{CO}_3 + \text{CaO} = \text{Na}_2\text{O} + \text{Ca CO}_3$: but other reactions also occur. Thus the lime removes much of the alumina and silica which previously existed in the solution as soluble salts of sodium, and in an insoluble form they are carried down with the carbonate of calcium, while, when air is used, part of the sulphide of sodium is converted as we have already stated, into sulphate. The use of bad lime often produces a liquor which will not settle well, and thus traces of lime are carried on further into the process of caustic making, and give future trouble. Eleven to sixteen cwt. of well-burnt lime are required per ton of 60 per cent. caustic soda, and one to one and a-half hour is consumed in the causticising operation. After settling, the liquors are run off, and the operation pan is charged afresh without removing the sludge until the second operation is completed. The lime-mud remaining after this, is washed by agitation with water, first in the pan, and then finally on a 'filter.'

This filter, as above stated, is generally half of a boiler which has been cut longitudinally in twain, but when specially made it is about 20 feet by 10 feet by 4 feet deep. The bottom is lined with bricks set on edge, about 2 inches apart, a channel being preserved along the central axis. These bricks are covered loosely with 8 or 9 inches thickness of coke or limestone, and over this comes a layer of coarse sand or cinders. Finally, over the whole are spread iron grids, so as to present flat surfaces from which the lime-mud when well washed and drained, can be readily removed. Sometimes this filtration is aided by the use of a vacuum pump, and in any

case it should be continued, until the mud contains about 50 per cent water, and gives up to water about 1 per cent. caustic soda. The composition of this lime-mud, just as it is used in black ash making, is indicated by the following analyses by Mr. G. E. Davis.

Analyses of lime-mud	A	B
{ Calcium hydrate	2·825	2·652
{ Sodium	1·906	1·663
" chloride and sulphate	0·244	0·206
Calcium carbonate	40·170	42·031
" hydrate	3·756	3·072
Silica	0·673	0·774
Alumina	0·255	0·324
Iron peroxide	0·048	0·708
Magnesia	0·086	0·095
Soda	1·832	1·600
Water	47·986	46·577
	99·781	99·702

The bracketed constituents represent the part soluble in 100 cc. water at 100° C., calculating the amounts from the results obtained in experimenting upon 5 grms. Many attempts have been made to reconvert this lime-mud into caustic lime for use over again in the causticiser, but the process is too expensive; moreover, by using it in the black ash making, most of the soda it contains is returned to the process. The washings of the lime-mud are used for diluting fresh quantities of vat liquor.

The causticised liquors of from 14° to 16° Tw. are now ready for concentration, an operation often effected in ordinary boilers until the strength reaches 30° Tw.; after this, it is not advisable to evaporate them in the boilers, for not only does the sulphide of sodium act injuriously on the plates, but deposits are formed which

it is best, or many obvious reasons, to avoid. The further concentration is therefore effected in 'boat-pans,' which were first introduced by Mr. Gamble. This shape admits of the ready removal of the salts which are deposited in the pans after a time. A number (two or more) of such pans are generally worked in concert, and are heated by the waste heat from the black ash furnaces, by being built over the flues leading from them.

These pans are either of wrought or cast iron, and are sometimes built on the tops of the furnaces themselves; but this plan is not to be recommended, for besides the great pressure thus brought to bear upon the latter, leakages into the furnace may occur and lead to a stoppage, not only of the pans, but also of the furnaces. The pans are about 12 feet long by 8 feet wide, and at the deepest part 3 feet. When about 35° to 40° Tw. (cold), the liquors are run into the 'strong pans,' where the evaporation is allowed to proceed until the liquors are at 280° Fahr., and test when hot, about 60° Tw. Meanwhile, 'salts' are deposited, consisting of carbonate, sulphate, and chloride of sodium, together with some caustic soda, etc. These are fished out, and in some works a small amount of soda nitre is now added to the liquors, but this is better done at a later stage.

The concentration of the liquors is still further prosecuted in the strong pans which are self-fired, until they indicate 70–72° Tw., if 60 per cent. caustic is desired, or 80–85° Tw. if 70 per cent. caustic is the product desired. The fires are then withdrawn, and the liquors allowed to settle; they are afterwards baled out into the 'pots,' and the deposited salts are treated along with those previously obtained, as hereafter to be described.

The 'pots,' which are of wrought or cast iron, are constructed to hold 8 or 10 tons of finished caustic soda, being 9 feet in diameter, $5\frac{1}{2}$ feet deep, and self-fired (figs. 18 and 19). These pots are liable to wear out by the

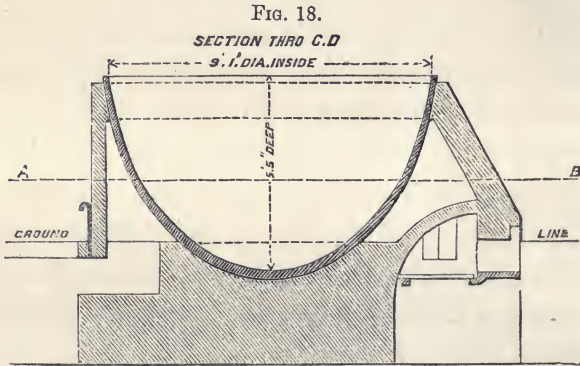

direct play of the fire upon them, which is sure to find out the weak points, and which produces holes in specific

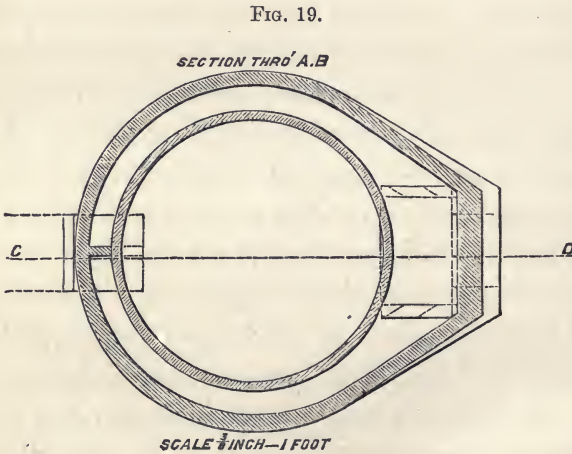

spots; or else at times they crack. To avoid these misfortunes, they are turned from time to time to present fresh faces to the fire. The pots are set in the ground in a

frame of brickwork ; but the particular way in which they are set varies in almost every work. One manager will so arrange that the fire plays round the pot in a kind of worm, and eventually escapes to the flue ; whilst another will split the flame by brickwork and send it round the pot in two opposite directions, meeting at the other side, and so on.

About five pans of liquor are required to furnish one pot of caustic. Usually three pots are used in succession, the first being replenished from the pans, and the second from the first, and the third from the second. More salts are deposited in the first pot, and these are fished out and united with those obtained from the pans. Altogether, about two tons of salts are produced per ten tons of caustic, and these salts being used instead of sodium sulphate for making fresh black ash, carry back into the process about five cwt. of caustic, eighteen cwt. of carbonate of sodium, and thirteen cwt. of sulphate of sodium (Mr. Morrison). The various arrangements for concentration all incline downwards, and the transfer of liquor is effected by means of bales and spouts.

At 250° Fahr. the liquor in the pot boils and froths while ammonia is evolved, and salts are deposited until liquor is 85° to 90° Tw., when the liquor is dark and boils at 311° Fahr. (155° C.). The ammonia is produced—*a*, by decomposition of the cyanogen compounds ; *b*, by removal of oxygen from water by the sulphides, while the hydrogen reduces the nitric acid to the form of ammonia.¹

¹ Hoffmann's 'Jury Report,' 1862.

Strength of Solutions of Caustic Soda (Dalton).

Sp. Gr.	Na ₂ O in 100	Sp. Gr.	Na ₂ O in 100.
1.56	41.2	1.32	23.0
1.50	36.8	1.29	19.0
1.47	34.0	1.23	16.0
1.44	31.0	1.18	13.0
1.40	29.0	1.12	9.0
1.36	26.0	1.06	4.7

At 400° Fahr. the liquors in the pot are darker, and the vapours are irritating, while at 500° Fahr. they boil gently, and presently on increased firing the boil ceases and graphite separates. This separation of graphite was first observed by Dr. Pauli, and proceeds from the decomposition of the cyanides, nitrogen being also evolved.

The pots are now loosely covered either with sheet iron, or with covers with which they are at times specially provided, and the fire is urged until the contents of the vessel are at a dull red heat. This consumes the graphite and 'clears' the 'pot,' after which the oxidation of the sulphides is effected, either by the addition of soda nitre or by a current of air. Before oxidation there is contained about 1.5 to 2 per cent. sulphide, or 35 lb. per ton, and this quantity requires 29 lb. of oxygen for conversion into sulphate. This amount of oxygen is contained in 56 lb. of nitre, or about 30,000 cubic feet of air. When air is used, it is pumped in by means of the same engine as that which supplies the current of air for the causticiser, and is conveyed by means of an iron pipe.

The action of soda nitre upon sulphide of sodium is represented as follows:—

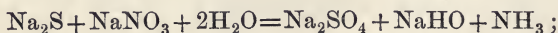

or at higher temperatures,

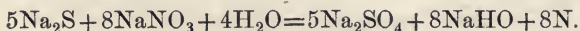

During the same operation the sulphide of iron becomes converted into ferric oxide.

It is estimated that about half of the nitre used, is returned as caustic soda, but its economical employment depends upon the relative market values of caustic soda and nitre. Its employment has certainly the advantage of consuming only four or five hours in the operation, whereas atmospheric oxidation takes a much longer time. In either case the oxidation is allowed to proceed till no sulphides are present, which is ascertained by pouring out a little of the fused caustic on a shovel and testing it with acetate of lead.

It is possible to over-oxidise a pot, that is to make it 'green' in colour. This colour is derived from the manganese, which in its turn is derived from the lime. The manganese, in the presence of sulphides, exists as lower oxide, but under the circumstances stated, forms manganate of sodium, which has a green colour. This over-oxidation may be remedied by the introduction of a few balefuls of fresh unoxidised liquor.

It now only remains to reduce the strength of the 'caustic' in the pots to that which is desired, and this is done by the addition of salt, an agent which is cheap, and which by its presence does not interfere with the future uses of the product. For a caustic to contain 60 per cent. Na_2O when packed, it must test, before 'salting,' 68 to 70 per cent. Na_2O , while, when it is desired to pack 70 per cent. caustic, it should test before salting, 72 per cent. Na_2O . The quantity of salt which has to be added is based upon these determinations, and on its introduction a loud crackling noise is produced, while a fine cloud of hot spray is thrown up, which makes its

presence in the air felt most unmistakably by any persons in its neighbourhood.

This operation concluded, the pot is again 'brought up to heat,' then the fires are withdrawn, and the contents of the vessel, after settling during eight to twelve hours, are ready for packing. This last proceeding is effected by baling out the fused mass into the sheet-iron drums previously alluded to. This is best done in instalments, with intervals between each, so as to prevent the formation of the hollow core which would otherwise obtain throughout the mass, by too sudden contraction into the solid state. These drums of caustic soda contain about five cwt. each.

The composition of 60 per cent. and 70 per cent. caustic soda is as follows:—

Constituents	60 per cent. Na ₂ O	70 per cent. Na ₂ O
Sodium hydrate . . .	70 to 73 per cent.	82 to 89 per cent.
„ carbonate . . .	1·5 to 6 „	2 to 5 „
„ chloride . . .	18 to 19 „	3 to 7 „
„ sulphate . . .	5·5 to 6·5 „	3 to 6 „
„ sulphite . . .	traces	traces
„ silicate . . .	0·2 to 0·5 „	0·2 to 5 „
„ aluminate . . .	traces	traces

The whole of the contents of the 'pots' are not, however, of this nature, for, during the settling, there is deposited a denser layer, containing much ferric oxide, silica, and alumina. In fact, this deposit, known as 'bottoms,' ranges about seven cwt. per pot of 10 tons of 60 per cent. caustic. Sometimes it finds a market as 54 per cent. caustic, but is generally worked up to furnish fresh liquor in the causticiser, leaving, as far as it is possible, the ferric oxide behind; or it is dissolved up and mixed

with the 'red liquors,' from which is made what is called 'cream soda.'

'Red liquor' is the mother-liquor left behind, after the separation by concentration, of the carbonate of sodium and other salts present in vat liquor destined to furnish sodic carbonate. These salts are freed from the liquor by rotation in centrifugal machines which were introduced into the trade by Mr. Gamble. The liquors, of specific gravity 1.5, derive their red colour from the presence of a soluble double sulphide of iron and sodium; they are treated as follows:—Concentration is resorted to until the temperature of the solutions is about 250° Fahr., when it averages 70° Tw.; they are then allowed to cool, and the deposited salts fished out. The concentration is then continued till the density of the liquors is about 94° Tw.; meanwhile 2 or 3 cwt. of nitre are added, after which they are run off, settled, and finally transferred to the pots, which are fired till the soda tests 60 per cent. alkali. At this point igneous fusion has not set in, and, therefore, the product contains water over that quantity necessary for the soda to exist as hydrate. No 'bottoms' are obtained in this method, and the oxidation in the pots is dispensed with. Mr. Morrison gives the following analysis of a sample of 'cream caustic' (60 per cent.):—

NaHO	70.00
Na ₂ CO ₃	5.00
NaCl	7.00
Na ₂ SO ₄	2.00
Water	15.80
Insoluble	0.20
	<hr/>
	100.00

Finally, we should state that the salts which are



fished out from the various liquors during concentration, are used up in black ash making, in the place of sulphate of sodium, so that most of the soda therein contained, is returned to the process. It should be further stated that the way in which the causticised liquors are concentrated, differs in particulars in almost every works, but the general principles observed, remain the same as those we have described. In the evaporation of the liquors there is experienced a considerable loss of soda, amounting to, perhaps, 5 or 6 per cent., as estimated by Dr. C. R. A. Wright, but to much less as estimated by others. When it is considered, however, that the total loss of soda in making alkali of commerce, amounts to about 13 per cent., and that the whole of the sulphur contained in the salt-cake employed, was, until the last few years, wasted, it is not surprising that many attempts have been made to obviate these evils. Some of these attempts have reference to matters already described, while others have aimed at superseding Leblanc's process entirely. In the next chapter we shall treat of the various methods of extracting from the 'tank waste' the sulphur it contains.

CHAPTER IX.

ALKALI WASTE ; REGENERATION OF THE SULPHUR ; MANUFACTURE OF HYPOSULPHITE OF SODIUM.

ALKALI waste constitutes the residual matter remaining in the vats after the carbonate of sodium and other soluble matters have been for the most part extracted by means of warm water. For every ton of soda ash produced, there are from $1\frac{1}{2}$ to 2 tons of residual waste, so that it accumulates in the districts of large works at the rate of 500 or 600 tons per week ; and when it is considered that there are consumed annually 300,000 or 400,000 tons of pyrites, we are enabled to get an idea of the total enormous amount of waste produced. Now soda-waste contains from 15 to 20 per cent. sulphur, and Mr. Gossage has shown that this quantity represents nine-tenths of the total sulphur contained in the original pyrites, while by the pyrites two-fifths of the whole cost of the raw materials used in soda-making are incurred. No subject has presented more difficulty in treatment than that of waste, so that for years it has accumulated, and has evolved poisonous gases into the air, and given off offensive drainings which have polluted many streams. Nevertheless, this nuisance has not existed so long through any lack of investigation ; processes upon processes have been devised, but until quite recently none of them have been

attended with that success which is essential to a large industry.

The composition of waste may be seen from the following analyses of Muspratt and Dawson :—

Constituents	Fresh waste	Six weeks old
CaCO ₃	41·20	23·42
Mg SiO ₃	3·63	1·78
Phos. Al (Fe ₂ O ₃)	8·91	7·40
Ca SO ₄	2·53	4·59
Ca H ₂ O ₂	8·72	12·03
CaS ₂	5·97	0·62
CaS	25·79	36·70
Na ₂ S	1·44	2·87
Water	1·73	10·59

In 1848 this material was recommended as a manure by Mr. P. Ward, but, as might have been inferred from the nature of the material, this application proved anything but successful. Mr. Deacon, many years ago, used it for making floors, but for the most part it has been used for filling up pits from which clay has been removed for brick-making.

It would serve but little purpose to sketch the many processes that have been at various times suggested for dealing with this waste chemically, so as to obtain saleable products. We shall, therefore, only allude to those which have either proved in a measure successful, or which serve to delineate the history of those at present in work.

Mr. Gossage endeavoured to decompose the sulphides contained in waste while it was yet in the vats, through the agency of impure carbonic anhydride. For this purpose coke or coal, or these together with limestone, were burnt in kilns, and the resulting gases were caused to

filter through the waste, the vats containing it being provided with covers and suitable arrangements. Instead of carbonic acid, hydrochloric acid or the acid liquors from the stills could at that time be employed, and in this way a current of mixed carbonic acid and sulphuretted hydrogen gases were obtained. The last portions of gas were ejected by means of steam, or, as stated in a later specification, steam alone could be used without either hydrochloric or carbonic acid. The resulting gases admitted of treatment in several ways.

In one system, they were mixed with more carbonic acid, and air or sulphurous acid, and the total mixture heated to redness, giving free sulphur and water. Or the sulphuretted hydrogen could be burnt into sulphurous acid, to be used for making sulphuric acid. This, however, would not work on account of the excessive dilution of the sulphurous acid with the nitrogen of the air employed to burn the hydrothion. Mr. Gossage therefore condensed the sulphurous acid in a tower, and so obtained a solution, from which he expelled the sulphurous acid gas by allowing it to percolate downwards through another tower in which it met a current of hot air. In this case some sulphuric acid formed direct, while the rest of the sulphurous acid went to the chambers. Unfortunately, none of these methods worked well in practice.

When that form of the process which employed the acid liquors from the stills was used, the free chlorine in the acid caused the separation of a certain quantity of sulphur, and the excess of acid being neutralised by the lime, a quantity of sulphide of manganese was likewise produced in the waste. In this way the residual product

admitted, it was thought, of utilisation by burning in the ordinary way to furnish sulphurous anhydride.

Lee proposed to burn the sulphuretted hydrogen obtained from the waste as above, into sulphurous anhydride, to be then passed through a fire of coke or coal, which maintained a chamber at a red heat. This chamber was packed with bricks, and through the interstices the products of combustion escaped into other chambers. Mutual decomposition of the gases occurred in the hot chambers; the sulphurous anhydride being reduced by carbonic anhydride, giving sulphur and carbonic oxide, which latter served to decompose a further quantity of sulphurous acid, or any bisulphide of carbon or sulphuretted hydrogen that might be present. The sulphur was obtained on cooling the vapours issuing at the end of the hot chamber.

Other inventors treated the waste in the manner already described for obtaining sulphuretted hydrogen, and caused this to react with sulphurous anhydride, giving water and sulphur.

M. Favre brought the hydrosulphuric acid into contact with moist sulphurous anhydride, while Mr. Duclo obtained similar results by passing sulphurous acid gas into an aqueous solution of sulphuretted hydrogen. The reaction which takes place under these conditions is generally represented in text-books as follows¹:—

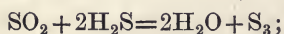

but no matter which of the above modifications of experiment was employed, pentathionic acid ($\text{H}_2\text{S}_5\text{O}_6$) was

¹ It may be here stated that a chemical equation is not by any means a mathematical one, and simply expresses generally the chief reaction that occurs between two or more substances, while it fails to express the secondary reactions generally attendant upon the primary one.

invariably formed and in some cases one-fifth of the total sulphur was lost in this way.

Mr. Weldon, after a long series of experiments, appears to have perfected the process just described, and so avoids the formation of pentathionic acid. This he does by passing sulphuretted hydrogen gas into a *solution* of sulphurous acid. Water dissolves at 67° Fahr. thirty-seven times its own volume of sulphurous anhydride, and so a solution is readily to be obtained. There are considerations, however, which render it extremely unlikely that such a process can ever be employed except for utilising the sulphur in alkali waste, and, perhaps, not even in that case, for, as we shall presently see, other processes actually in work do this equally well.

Mr. T. Spencer, in 1859 and 1860, proposed to absorb the sulphuretted hydrogen by dry sesquioxide of iron, and to expose the product to atmospheric oxidation, reproducing the sesquioxide and giving free sulphur; these processes to be repeated until the sulphur had accumulated in quantity sufficient to burn the material for supplying sulphurous anhydride to the chambers. This is practically the same process as Hill's, which is applied to purify coal-gas and which has been already described under 'Sulphuric Acid Manufacture.'

In relation to this last subject C. Méne states that at the Vaise station of the Lyons gasworks the oxide of iron is regenerated as follows:—When ready, it is placed in a tank of iron, which is filled and hermetically closed. Steam is then admitted at the bottom or sides, while from the top another pipe carries off the sulphuretted hydrogen resulting from the action of low-pressure steam upon ferrous sulphide. Actual decomposition of water

is said to occur, ferric oxide being regenerated, and the hydrothion escaping. One fails to perceive the advantage of this process, even if it worked successfully and without formation of any sulphate of iron, seeing that the hydrothion is lost, whereas in Hill's process it is regained to make sulphuric acid.

In 1838 Mr. Gossage demonstrated the decomposition of one equivalent of sulphide of calcium by one equivalent of carbonic acid, and the same for sulphide of sodium; and at the British Association in 1861 he stated his conviction that the recovery of the sulphur would be effected in this way in future years, thus producing carbonate of soda and giving hydrothion to be absorbed by ferric oxide for use in the manufacture of sulphuric acid. Recently Mr. Walter Weldon has taken out a patent for a developed form of this process; or it may be applied to hydrothion generated from soda waste.

As a soda process, sulphide of sodium is first prepared by fluxing in a close furnace a mixture of fine coal and salt-cake in the proper proportions, and lixiviation of the product in water. The sulphide of sodium liquor so obtained is decomposed by carbonic acid, giving sodic carbonate which may be crystallised out of the solution and further purified by recrystallisation. Thus

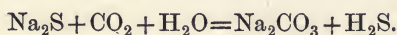

This latter gas passes on to a series of iron vessels containing water or an alkaline solution holding in suspension hydrated peroxide of iron (as bog-iron ochre). The ferric oxide absorbs the gas thus,



at the completion of the operation the ferrous sulphide

is oxidised by blowing air through the mixture, in this way the combined sulphur is liberated :

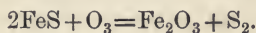

These operations of sulphurising and oxidising are repeated again and again till the sulphur has accumulated to an extent sufficient to remove (85 sulphur to 15 oxide), when the iron oxide is dissolved out by acid, leaving the sulphur which is now ready to refine. If desirable, the ferric oxide can be regained from the acid solution by precipitation with lime.

Now, in regard to this process, a difficulty appears to exist in making sulphide of sodium from salt-cake by reduction as described. In the first place, the sulphide of sodium speedily destroys a furnace of the ordinary kind ; secondly, it is impossible in such a furnace, to prevent the oxidation of the sulphide into hyposulphite, etc., while much soda appears to be lost by volatilisation. The first difficulty Mr. Weldon proposes to meet by using furnaces lined with carbon in the form of bricks as first used by Mr. Henderson. These bricks are made by mixing powdered coke with a small quantity of tar ; the mixture is then moulded and exposed to a red heat.

In revolving furnaces lined with such materials it is proposed first to heat powdered coke to incandescence, while in another Siemens' furnace the salt-cake is heated, perhaps to fusion. The reaction is to be effected in the carbon-lined furnace, which will be so disposed and arranged that while it admits of being heated in the ordinary way, the opening at which the products of combustion enter can also be closed at will, while the opening at the other end is to be placed in communication with a gas-holder. In this way Mr. Weldon hopes to surmount

the difficulties above enumerated. As regards the other part of the process there seems to be but little difficulty, except it be of that nature which necessarily attends any new process. We refer, of course, to the disposal and arrangement of the plant, etc.

On many series of experiments relative to these processes the author was, some years ago, engaged for Mr. Weldon, and he can testify to the complete success which attended them in the laboratory. At the same time, however, there are dangers to be apprehended, even if the obstacles attending the manufacture of the sulphide of sodium are overcome. Thus, during the lixiviation of the furnace product, it will be a matter of difficulty to avoid a very considerable oxidation; and further, it has yet, of course, to be proved that carbonic acid can be obtained on a sufficiently cheap scale, in order to effect that which is certainly to be desired—the object of the process.

In concluding our remarks on this matter, we may point out that Mr. Weldon has also patented the use of ferric salts in solution, for fulfilling the same purposes as ferric oxide, and they also admit of regeneration by oxidation.

While writing about sulphuretted hydrogen and sodium chloride, it may here be stated that the author of this work has shown, in a paper read before the Chemical Society, that sulphuretted hydrogen converts sodium chloride into sodium sulphide at high temperatures, with the evolution of hydrochloric acid; and although the percentage of salt decomposed in these experiments never exceeded 15 per cent., yet, nevertheless, they were performed under unfavourable circumstances, and therefore

further experiments are well worth making. The results which were obtained are here tabulated :—

Sodium chloride used in experiment	Duration of experiment	Temperature employed	Per cent. of NaCl decomposed
3·123	1 hour.	Sufficient to fuse salt.	6·00
3·123	1 "	"	15·00
3·123	2 "	Much higher.	3·38
·301	10 minutes.	Below fusion.	1·10
·7215	30 "	"	·94
3·0587	40 "	Very high.	5·51
1·0565	45 "	Below fusion.	1·71
·844	2 hours.	Partial fusion.	2·21
2·005	1 "	To fusion.	·93
1·4864	1 "	"	1·78
·939	2 "	"	8·18
1·056	3 "	"	5·99
·500	2 "	"	8·12

With the process for recovering from alkali waste the mass of sulphur it contains, that we next proceed to describe, the names of Guckelberger, Mond, and Schaffner are associated. Guckelberger and Mond seem to have worked together to a great extent, the work being continued afterwards by Mond alone. Schaffner's investigations, so far as we propose to enter into them here, have to do only with the purification of the sulphur prepared from the waste.

The chemical reactions involved in the process were first proposed for realisation on a manufacturing scale by Mr. Thomas H. Leighton in 1836, and long before Mr. L. Mond introduced the process in an improved form, it had actually been in use at various works in Great Britain.

Where the process is employed, in addition to the four tanks or vats usually employed in a series, for lixiviation of black ash, six others are used. Three of these

For good working results, the liquors should contain at least one equivalent of CaS_2O_3 for every two of CaS_2 , and one of CaS_2O_3 for every one of CaH_2S_2 (according to Mond). Practically they may be said to consist of hypsulphites and sulphides, and it is an object to obtain these constituents in such relative proportions as may be required on treatment with acid to yield sulphuretted hydrogen and sulphurous acid in the quantities necessary to produce only sulphur and water.

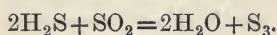

The liquors are allowed to settle in tanks, and are then run into a wooden vessel lined with lead, of 10 to 12 feet diameter, and 3 to 6 feet in height, and maintained at a temperature of 140° to 150° Fahr. by steam. Hydrochloric acid of 20° B. is now added, then more sulphur liquor, then more acid, and so forth alternately, in the proportion of 8 : 1 or 7 : 1. Meanwhile the temperature is maintained (60° C.), and the liquors are kept in agitation until the vessel is sufficiently full, when acid is finally added until an odour of sulphurous anhydride is perceptible. Into other tanks the liquors after being so treated are then run, and here the sulphur speedily settles, and is then washed by a stream of water. Finally, it is raked out into drainers below, constructed of bricks and tiles, which are heated underneath. The resulting product contains 60 per cent. water, and it then only remains to be melted and refined in an apparatus which has been improved by Schaffner.

Through the kindness of Messrs. Dalglish and Co. we are enabled to reproduce here a sketch (fig. 20) of a steam sulphur melter as commonly employed. In such an apparatus the sulphur is exposed to steam at a pres-

sure of 20 lb. to the inch, when it melts and sets free the water, which floats on the top of the molten sulphur. Sulphate of calcium and other impurities subside to the bottom, and the fluid sulphur is blown off by the steam into moulds or tubs. If the hydrochloric acid used in its manufacture be free from arsenic, so also will be the sulphur, which is useful not only for the manu-

FIG. 20.

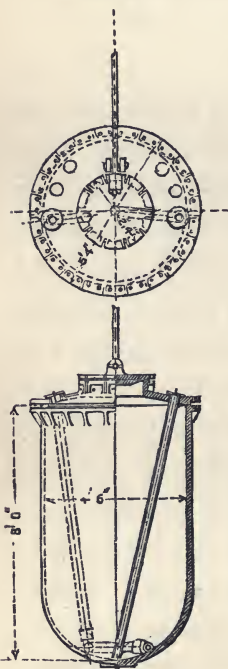

facture of pure sulphuric acid, but also in the preparation of gunpowder, for which purpose it is most largely used. The amount of sulphur so recovered varies, but Mr. Mond states that he has obtained as much as 60 per cent. of the total amount contained in waste; practically, however, not more, we believe, than two-fifths are recovered.

M. Schaffner shows that alkali waste after this treatment consists principally of carbonate and sulphate of calcium, together with some calcic sulphite. He further credits it with the power of preserving railway sleepers, while it is also stated to be of use as a manure and for building purposes.

Notwithstanding the merits of the process we have described, it has proved remunerative in the hands of but few manufacturers, and is not largely used on account of the small profit realised by its working.

The sulphur recovery process worked on the largest scale in this country is Mactear's. The process is in work at St. Rollox, Glasgow, where I am informed by

Mr. James Mactear that about 30 tons of sulphur per week are made by his process, and more could be made were it required. This process has two modifications. In the one, the yellow liquors obtained by collecting the drainage from the waste, or by oxidising and lixiviating the waste, are mixed with lime in a finely divided and hydrated state, and submitted to the action of sulphurous acid in a wooden vat fitted with an agitator. The sulphurous acid is absorbed, and seeing the yellow liquors consist chiefly of calcium sulphides, some sulphur is deposited. At the same time that sulphur is precipitated, calcium hyposulphite forms, and some hydrothion is evolved. The liquor is now mixed with fresh yellow liquor in suitable proportions, preferably so as to contain an equivalent of calcic hyposulphite to each two equivalents of calcic bisulphide, and one of hyposulphite (CaS_2O_3) to one of sulph-hydrate of calcium (CaSHS). The hydrothion evolved is passed into liquor which has been previously treated with sulphurous acid, so that it is thereby decomposed, with precipitation of sulphur. Or it may be passed into milk of lime, and the product added to fresh yellow liquors requiring treatment. The liquors treated as above set forth are now decomposed with hydrochloric acid in suitable wooden vessels, thus giving a solution of calcic chloride (CaCl_2) and sulphur, which latter is collected and dried, or melted for use or sale.

The other modification, being the one which is actually used at St. Rollox, is as follows:—The yellow liquors, without being treated with lime, are placed in a wooden vat provided with an agitator, and kept stirred while a solution of sulphurous acid is run in. Prac-

tically hydrochloric acid is added to the yellow liquor, sulphurous acid being run in along with the other two streams, keeping the temperature at about 145° Fahr., and proportioning the streams as to yield chloride of calcium and sulphur, which is collected, washed, and dried as before described.

It is of some interest to note that when alloxan (an oxidation product of uric acid) is treated with sulphuretted hydrogen, alloxanthine is formed, and sulphur set free, thus—

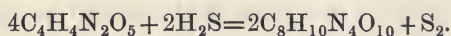

Could the alloxan be regenerated from the alloxanthine, a process might be worked out for the recovery of sulphur in this way. Now, it is well known that alloxanthine may be reconverted into alloxan by moistening it with a mixture of 2 parts fuming nitric acid (1.52 sp. gr.) with one part of ordinary nitric acid (1.42 sp. gr.), when nitrous acid is copiously evolved, and after some time the reaction is complete.

Here, therefore, we have chemical grounds for a process to recover the sulphur from waste, and without any loss of nitric acid, for the nitrous acid evolved could be again converted into nitric acid for further use. The alloxan could be made from guano.

It is worthy of record that among other unsuccessful undertakings for the regeneration of sulphur from waste, is one which originated with Mr. I. Lowthian Bell. He proposed to make factitious pyrites (so called) by heating in a blast-furnace a mixture of soda waste and the residue left by burning pyrites. So far as the mere union of the sulphur and the iron was concerned, the undertaking was

eminently successful, and, in fact, some 2,000 to 3,000 tons of the factitious pyrites were actually made. But, beyond certain destructive influences on the furnaces, the cost was too great at the time to warrant continuation of the manufacture; not only so, but the difficulty was increased by the discovery that the product could only be burnt so as to regain the sulphur for chamber consumption, when in union with coal-brasses or native pyrites. Nevertheless, Mr. Bell has pointed out that should native pyrites experience an improvement in price, or coal a great deterioration, the process might, after all, be employed more or less widely. The least that can be said of the process is, that it was as ingenious as the undertaking was commendable.

While treating of alkali waste we may conveniently refer to the manufacture of hyposulphite of sodium, although this substance is not largely produced. Its production in Great Britain is, we believe, confined to the Tyne district, and at Walker the process which is followed, is somewhat as now to be stated.

Tank or vat waste is exposed to the atmosphere, whereby the sulphides of calcium are converted into hyposulphite. The product is made into a thin paste or solution with water, and is then heated with sulphate or carbonate of sodium. In this way sulphate or carbonate of calcium is precipitated, while sodic hyposulphite remains in the solution, and is obtained therefrom on concentration and crystallisation.

In 1863 about five tons were made weekly by this method at Walker-on-Tyne. Another process, used at Newcastle, consists in the reduction of sulphate of sodium

to sulphide by means of coal, in a close furnace. The 'balls' which result from this operation are extracted with water, and the solution after settling, is exposed to a current of sulphurous anhydride. It is then concentrated in the open air, and on cooling the sodic hyposulphite crystallises out.

CHAPTER X.

SODA PROCESSES OTHER THAN LEBLANC'S, INCLUDING THE
'AMMONIA PROCESS.'

UNDER this heading it is our intention to briefly indicate, and in some measure describe, processes which have been proposed from time to time, either as supplementary to, or substitutive of, the one in general use. Most of them are improved modifications of old processes, and have been tried on a limited scale, while others are actually in use to a small extent.

Some years ago Mr. Hunt proposed a process, founded on some experiments of Mr. Gossage, and which, indeed, was an old friend in a new garb. It was proposed to obtain crude sulphide of sodium by fluxing salt-cake with coke or coal; the product was to be broken into lumps and placed in iron cisterns provided with false bottoms, under which carbonic anhydride was forced, the gases passing out at the top. Each vessel was to be heated by steam, and the carbonate of sodium so obtained to be purified by recrystallisation. As for the sulphuretted hydrogen evolved in the reaction, this was mixed with air and burnt under a stratum of oxide of iron kept red-hot by the burning gases, and in this way sulphurous anhydride was produced for use in the chambers. The chief difficulties encountered in the working of such a process are those which Mr. Weldon hopes to avoid,

and as we have already described his process and its advantages in our last chapter, we may pass from its consideration.

Mr. Arrot, Mr. Hunt, and others have also proposed at various times to manufacture caustic soda from the sulphide made as above, by the use of oxides, such, for instance, as those of iron, manganese, zinc, and copper. Where iron is used, a double compound of sulphide of iron and sodium results, which is difficult to manipulate. But in any case a greater difficulty so far, consists in the manufacture of the sodic sulphide. This has been attempted by causing a fused stream of sulphate of sodium to flow through red-hot coke or coal, but with partial success. If by Weldon's plan, good results should be obtained, then these various other processes would merit reconsideration.

The processes we shall next describe, refer to the extraction of soda contained in felspar, cryolite, and other minerals.

Ward proposed to frit any natural silicate, as pumicestone, with calcium fluoride and chalk, in a reverberatory furnace, by which operation, supplemented by lixiviation of the product, a solution of caustic soda is obtained; the residuum he employed as a hydraulic cement.

Newton patented the use of the following proportions:—100 parts felspar, 50 parts phosphate of lime, and 300 to 400 parts of lime, all in powder. This mixture was calcined at a low red heat for two hours, by which means there are formed silicate of lime and phosphate of sodium; the silicate of lime combines with the silicate of alumina, and on lixiviation, the lime decomposes the phosphate of sodium, reproducing phosphate of lime and

giving caustic soda, which remains in solution. The residue obtained in these operations was recommended as a manure.

The attempts to obtain soda from cryolite, which is a double fluoride of sodium and aluminium, originated with Spilisbury, and were revived by Moigno. But it is by a process devised by Julius Thomsen in 1850, that such an amount of soda is actually manufactured at the present day, as to consume annually 12,000 to 15,000 tons of cryolite. Cryolite occurs almost exclusively in South Greenland, where it forms a solid mass of about 600 feet in length and 200 feet in width, and of unknown depth. This mine is the property of the Danish Government.

The following description of the manufacture of soda from this mineral is taken from a paper by J. Lawrence Smith. The decomposing agent employed is lime, and the process can be performed either in the wet or dry.

The Dry Process.—The cryolite, crushed to powder, is mixed with slaked lime or powdered chalk in such proportions that for each equivalent of pure cryolite there shall be rather more than six equivalents of lime. In the next process of calcination, the great difficulty of the process is encountered. The heat must only be great enough to effect the decomposition, for if the temperature exceeds this, the materials fuse, and produce a product it is impossible to lixivate. About two hours are required to complete the decomposition of a charge of 1,000 lb., and the product, when properly made, is a granular loose mass of an ash colour. After cooling, it is lixiviated by water, and yields a solution of soda and sodium aluminate, which marks on an average 26° to 28° Baumé. The

liquors are placed in large horizontal cylinders, provided with agitators, where the solution is treated with carbonic acid, produced by the combustion of coke and washed with water, by being made to traverse stacks of faggots over which water trickles. The carbonic acid converts the caustic soda and aluminate into carbonate, setting free the alumina, thus—

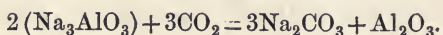

The liquors now mark about 31° Baumé, and furnish soda, while the alumina is allowed to settle, and in this state of granular powder constitutes a valuable source of alums. The carbonate of soda obtained is tolerably pure, containing only 1 or 2 per cent. of sulphate of sodium, derived from the sulphides associated with the cryolite.

The Wet Process differs from the dry, according as the required product be carbonate, or caustic soda. If carbonate be desired, the proportions above stated are used; but when caustic is the desideratum, fifteen equivalents of lime are employed to two of cryolite, the resulting products being caustic soda, aluminate of lime, and fluoride of calcium, which last-named body is formed in either case. The operation is conducted in a large vertical cylinder heated by steam and provided with an agitator, and takes from two to three hours' boiling. The liquors are filtered and settled, and are treated with carbonic acid as above (with the same result) if carbonate of soda be desired. On the other hand, when caustic soda is required, the liquors are simply evaporated in the usual way, yielding caustic soda of 75 per cent.

The wet process has many advantages over the dry method, but inasmuch as lyes of only 10° Baumé are so

produced, there is an enormous consumption of fuel necessitated by evaporation.¹

There are four establishments in Germany consuming about 2,000 tons of cryolite annually, and in 1867 one was started in Pennsylvania for working 6,000 tons. At this works, in Natrona, caustic soda is made as above on a large scale. Bauxite (a mineral containing 80 per cent. of alumina) is sometimes mixed with the cryolite to increase the yield of alumina.

The following equations, although they may not represent exactly what occurs in the two forms of the process described, nevertheless do so fairly:—

1st. *Dry Process*—

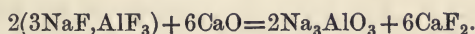

Any caustic soda present in the product would seem to result only from the presence of water in the lime used, thus—

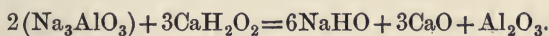

2nd. *Wet Process*—

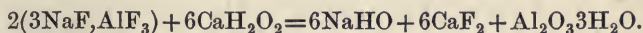

The various products manufactured from cryolite have a market value of more than \$1,500,000 in gold.

Allied to the processes just described are others in which salt is decomposed by silica and steam. Blanc and Blazille (1840) used a mixture of 280 parts of salt and 200 of sand, which was enclosed in red-hot iron cylinders, and exposed to a current of steam. In this

¹ It is not easy to see why four or five such cylinders should not be worked in a series, like as vats are worked in Lancashire. In this way the liquor from the first operation would be used in the second, and so on, and thus stronger liquors would be obtained.

way hydrochloric acid is evolved, and neutral sodic silicate produced. This latter was then fluxed with sodic carbonate, and the product dissolved in water, then treated with carbonic anhydride, thus obtaining the whole of the alkali as carbonate, and the silica in a finely-divided precipitated state, fit for use over again, or for glass-making. The evil of the process consists in the difficulty experienced in obtaining anything like a perfect decomposition of the salt, and the gelatinous nature of the precipitated silica.

Tilghmann (1847) and Fritzsche (1858) obtained neutral silicate of sodium in the same way, but treated it by lixiviation with water, and decomposition of the solution by caustic lime; but the silicate of lime so produced was so bulky, and had such a retentive nature for the caustic fluid, that the process did not succeed in practice. Tilghmann also attempted to decompose sulphate of sodium in the presence of alumina by hot steam, thus forming sulphuric acid, which was carried away by the steam, and aluminate of sodium, which was decomposed in water by carbonic acid, giving sodic carbonate, and regenerating the alumina. But the form of process with which the name of Tilghmann is most intimately associated employs common salt, alumina, and steam, in which case the following equations represent the reactions on which the process is based:—

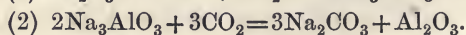
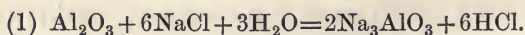

This beautiful process excited much attention some years since, but, in many experiments conducted at Glasgow, alkali of low strength only could be produced.

An interesting process was patented in Prussia, in

1867, for obtaining caustic soda and nitric acid from Chili saltpetre (NaNO_3). Equivalent quantities of this substance and chalk are heated in iron vessels, and the evolved gases conducted into water, giving, it is said, eleven-twelfths of the original nitric acid. The mass left in the retorts consists of lime and sodic carbonate; and this, on treatment with water, gives caustic soda, and regenerates the carbonate of calcium. This process might, perhaps, be worked with advantage in Chili and Peru, where soda nitre abounds; but here, the nitre is far too costly (for reasons previously given) to admit of the use of such a process. As regards the process itself, there appears to be a rapid destructive action on the iron pots; but it is not at all improbable that muffle furnaces could be used instead.

Sheridan, in 1837, proposed to decompose salt direct by highly heated steam; and in 1862, R. W. Swinbourne proposed to use superheated steam and *fused* salt. This is a very favourite idea with chemists; but to those who have repeated these observations it is well known that it is impracticable to get a perfect decomposition, and, moreover, the salt is volatile at a strong red heat. What reaction takes place, occurs but slowly, and very dilute hydrochloric acid is therefore obtained.

Patents for the decomposition of salt by means of electricity have also been secured by Cook in 1851, Watts in 1851, and Stanley in 1853.

We will now pass on to regard a new process proposed by Dr. Lunge, and described before the Newcastle-on-Tyne Chemical Society as follows:—‘Carbonic acid, made as rich and as pure as possible, is forced through a series of closed vessels, the first few, or “converters,”

containing a solution of sodium sulphate and barium carbonate; the next, which I will call "precipitators," standing at a higher elevation, and containing solution of barium sulphide, the escaping impure sulphuretted hydrogen being dealt with in any of the manners previously defined. The operation produces in the "converters" a precipitate of barium sulphate (which is afterwards reduced to sulphide and charged into the "precipitators") and a solution of sodium bicarbonate (which is boiled down and dried, yielding solid alkali and gaseous carbonic acid). The same operation produces in the precipitators, by the action of the residual carbonic acid, the conversion of barium sulphide into carbonate, which is run in the state of mud into the converters, and serves for a fresh operation there,' etc.

This process is based on the fact, discovered by Wagner, that bicarbonate of barium acts far more effectually in decomposing sulphate of sodium than the normal carbonate. M. Kuhlmann, however, found the operation impracticable on a large scale, but obtained better results by working under a pressure of four or five atmospheres. But such a pressure is awkward and costly to secure. The advantage thus presented, however, is due to the increased solubility of barium bicarbonate.

One advantage presented by Dr. Lunge's process is that pure carbonate of soda is obtained, and the theoretical quantity of artificially-prepared barium carbonate suffices; but if native witherite be used, four times this quantity is required. On a scale of several hundredweights, Dr. Lunge always found he could obtain a perfect conversion of the sulphate in three or four hours, even at ordinary atmospheric pressure; but in

working on a manufacturing scale by his apparatus, there would be a pressure of 15 lb. to the square inch in the first converter. As much as 99½ per cent. of the calculated sodium carbonate obtainable was realised in Dr. Lunge's experiments, and if this could be realised on a large scale, it would certainly compare very favourably with Leblanc's process, in which there is a loss of 12 to 15 per cent. on the theoretical quantity.

Ozouf's plan of obtaining pure carbonic acid would be useful here, if practicable. It consists in passing any impure carbonic acid through a solution of sodium carbonate, which retains the carbonic acid whilst foreign gases escape. The carbonic acid so absorbed is again expelled by heat. But Dr. Lunge considers the carbonic acid obtained by burning coke in a lime-kiln to be quite good enough, if it be cooled and washed. The greatest difficulty experienced in the process would be in dealing with the sulphuretted hydrogen.

The first start would be made with native heavy spar, and Dr. Lunge has convinced himself that 90 per cent. of the barium sulphate can be reduced by coal-dust in a good reverberatory furnace, contact with air being as much as possible avoided. On an average he obtained a reduction of 80 per cent., and that which escapes reduction is again obtained on lixiviation. In fact, the reduction of barium sulphate is effectually performed at one or two works on the Continent on a large scale.

Dr. Lunge concludes his paper in these words:—'I would not like to say that my process allows a given quantity of sulphate to be worked up as cheaply as Leblanc's process, for the reduction of barium sulphate will cost about as much labour and coals as the "ball-

ing" process.' There is also the cost of producing carbonic acid, and, in the present state of affairs, the loss of sulphur; but against this, the process does *not* present a loss of 12 to 15 per cent. alkali, and the product is free from sulphate, sulphite, and hyposulphite.

We have dwelt somewhat at length with these notes from Dr. Lunge's paper, because they contain many valuable hints, even if the process should never have an existence on an extended scale.

We might extend our considerations upon suggested processes for making soda yet very much; but as our object is not to exhaust the subject, but only to indicate the most reasonable ones, or those which are, or have been, actually in work, we shall only pause to notice two others.

The first of these is known as Bachel's process for making caustic soda, and may be said to constitute an improved form of the process originally employed by Lord Dundonald and Mr. Losh, at the end of the last century (1790-1799). This consisted in the decomposition of salt by means of litharge; but, as the process was then worked, less than 6 per cent. of the salt used was decomposed, and great loss of lead was experienced. Nevertheless, at that date caustic soda was thus made at a profit; and this need not surprise us, for Mr. R. Calvert Clapham has calculated that this product was then worth from 85*l.* to 90*l.* per ton of 70 per cent. In M. Bachel's process hydrate of lime is used in addition to salt and litharge, and with such a mixture many experiments were made at Walker (1869 and 1870), and have been described by Mr. Clapham.

The best results were obtained, using a mixture of

100 parts litharge, 70 parts salt, and 50 of lime. This mixture is ground on a mill with some water, so as to form a paste, and the reaction takes place at this stage, 19 or 20 per cent. of the salt being decomposed, forming chloride of lead, and giving caustic soda. Preferably, this liquor, which is obtained from the pulpy mass by pressure in a mill worked at a pressure of 145 lb. to the square inch, is used over again for treatment of fresh quantities of the original mixture, and so in this way 47 or 50 per cent. of the salt admits of decomposition.

Now this solution contains lead which has to be removed, and this is best done by filtration through hydrate of lime which can afterwards be used in the process. From the liquors thus freed from lead, caustic soda of 70 per cent. can be obtained in the ordinary way, if care be taken to fish out the common salt deposited on concentration. The cakes left in the press are dried at a temperature of 350° Fahr., by which operation the hydrate of lead is converted into yellow oxide, but higher oxides appear to form also, and these suffice, as is suggested by Mr. Clapham, to explain why this material does not act so well after it has been regenerated several times. The mass so dried, is thrown into boiling lime-water to decompose the chloride of lead, after which, and draining, it is ready for use over again in decomposing fresh quantities of salt. Although many difficulties were experienced in working this process, yet Mr. Clapham held out hopes that it would prove to make caustic at a cheaper rate than the one in almost universal use. Unfortunately, since the date of his paper, but little has been heard of the further history of the undertaking.

More than 20,000 tons of caustic soda are made

annually in England, of the value of 350,000*l.*, and, therefore, any question regarding an improvement in such a trade deserves the most careful study.

The only remaining plan of making soda that calls for study here, is technically known as the 'ammonia process,' and it is the only one which, as a rival to Leblanc's, has met with any measure of success. The following list of patents having reference to it, shows how great is the interest taken in it:—Dyer and Hemming (its inventors), in 1838; Schløesing, in 1854; Gossage, in 1854; Belford, in 1855; Schløesing and Rolland, in 1858; Solvay, in 1863; Solvay in 1867; Young, in 1871 and 1872; Solvay, in 1872; Weldon, in 1872 and 1873.

The process itself consists in treating a solution of salt with bicarbonate of ammonium, practically with carbonic acid gas and ammonia at the same time, to saturation. Bicarbonate of sodium is thus produced, and a solution of ammonic chloride results, from which the ammonia is regenerated. The process may be said to depend upon the relative solubility of chloride of ammonium and sodium bicarbonate, and therefore it is necessary to work with very strong solutions. Gossage prepared his bicarbonate of ammonium by exposing currents of carbonic anhydride and ammoniacal gas to a shower of water in a tower, and decomposed common salt either with the dry product, or direct by ammonia and carbonic anhydride. From the sodic bicarbonate so produced, the second molecule of carbonic anhydride was recovered by heating the substance in iron retorts. But he found the great difficulty of the process to exist in the loss of ammonia.

It has been stated that the following reaction cannot be realised in practice:—

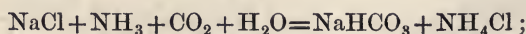

for with equivalent quantities of ammonia and salt, even when excess of carbonic anhydride is used, only two-thirds of the soda are obtained as bicarbonate, and thus a large amount of bicarbonate of ammonium is wasted. If two equivalents of salt be taken to one of ammonia, four-fifths of the ammonia are utilised, but much salt remains undecomposed. Moreover, carbonic anhydride must be employed in a pure state and under considerable pressure in order to insure perfect absorption.

These, however, constituted the objections (among others) to the process many years ago, while, as a matter of fact, many improvements have really been introduced, and, indeed, the process is in work at Couillet, Aix-la-Chapelle, Kasan, Northwich, and other places. The particular improvements effected by Honigmann, of Aachen, and Gerstenhöfer, of Freiberg, are kept secret, as are also some of the most important (according to statement) of Solvay's improvements. It is certain that some time ago 25,000 to 50,000 lb. of sodium carbonate were being made daily at Couillet, but there is much difficulty in ascertaining, even now, whether at that place, or anywhere else, it is fulfilling the expectations anticipated of the process.

According to one account, the process is conducted as follows:—A saturated solution of salt is made in vessels arranged on the same principles as lixiviating vats, and the solution of 23° or 24° is transferred to a vessel provided with a false bottom pierced with holes, wherein it is saturated with ammonia. Great heat is evolved, and the volume of liquid is sensibly augmented, so that it registers only 16° after this treatment. The solution is then cooled down by means of a worm of cold water, and

is then ready for treatment with carbonic anhydride. This is obtained either by roasting limestone, or treating it with acid, and passes, after washing in water, into the aforesaid solution which is contained in cylindrical vessels, or absorbers, 30 to 40 feet high, and with nearly a like diameter. The gas enters from below, under a pressure of 1.5 to 2 atmospheres, and by having to rise through the liquid, the temperature is kept within the desired limits. The liquid, saturated with carbonic anhydride, is drawn off every half hour, and the resulting bicarbonate of sodium is collected on a filter, washed with a little water, and is made then to pass down a tower, in which it meets hot gas or ascending steam. Passing alternately by a spiral arrangement from the centre to the circumference, and *vice versa*, it reaches the bottom as ordinary carbonate, ready for sale. The carbonic anhydride evolved in this last operation is conveyed to the absorbers.

According to Honigmann, in order to produce 10,000 lb. of carbonate of sodium, there are required—

Substances consumed	1.—90 per cent.	2.—95 per cent.	3.—98 per cent.
	lb.	lb.	lb.
Common salt	20,000	19,000	17,500
Coal	20,000	15,600	15,000
Limestone	15,000	18,000	13,000
Sulphuric acid (50° B.)	1,000	800	600
Ammonic chloride	500	400	300

The chloride of ammonium is employed to make up for losses in the process, while the sulphuric acid is used for absorption of ammonia.

Honigmann has been chiefly instrumental in introducing the process into Germany, and he works in a somewhat different way to Solvay, under whose patent the

works at Northwich are conducted. Honigmann's process is in work at Vagy and Bocsko, but late advices from Germany are to the effect that the process does not pay so well as was anticipated.

It is said that the plant required by either form of this process is very delicate and liable to get out of order, while it is also stated that for every ton of alkali produced, 5 per cent. of the ammonia used in the preparation is lost. Glassmakers have urged as an objection to the soda ash so made, that it is bulky; but at the same time it is very pure, as is shown by the following analysis of a sample by Mr. John Pattinson:—

Carbonate of sodium	98.72
Sulphate of sodium	0.20
Chloride of sodium	0.54
Carbonate of lime	0.13
Carbonate of magnesium	0.04
Peroxide of iron	0.01
Alumina	0.01
Silica	0.09
Moisture	0.32
	<hr/>
	100.00
	<hr/>
Sold by English alkalimetric test	58.50

In the process we have just described, there is obtained a solution of chloride of ammonium, and from this the ammonia has to be re-obtained. Originally lime was employed for this purpose, but recently (1872) Mr. Weldon has patented the use of magnesia for this purpose. In this way there is obtained magnesium chloride this may be evaporated down to a low bulk, and then heated in a furnace with steam, whereby hydrochloric acid is generated, and may be absorbed in the ordinary

Gossage towers, while magnesia remains in the furnace, and may be used over and over again.

In a later patent (1873) Mr. Weldon claims the use of artificial carbonate of magnesium for the same purpose, but the method of procedure is somewhat different. In this case the chloride of ammonium liquors are distilled with the carbonate, thus giving a distillate of ammoniac carbonate, and leaving behind chloride of magnesium. The magnesia obtained from the latter he converts again into carbonate by suspending it in water, and subjecting the milk to the action of carbonic anhydride from any source. It should be remarked that Mr. James Young had in 1872 patented the use of carbonate of calcium or magnesium for the same purpose, but no method for its constant regeneration as in Weldon's case.

Finally, we must direct attention to some improvements patented by Mr. James Young in 1871, having reference especially to the plant used in the ammonia process. He employs a series of air-tight vessels, which are so arranged as to admit of revolution, but as this form of plant has not been adopted, so far as we know, we may conclude this notice with a statement of the claims of the invention. These are, the boiling with water of the bicarbonate of soda, mixed with compounds of ammonia, or heating it by steam, so as to reduce it to carbonate of soda, by driving off and recovering a portion of the carbonic acid and the residual compounds of ammonia in the manner described; and the manufacture of carbonate of soda in the manner described, so that all the ammonia or compounds of ammonia are always kept within air-tight apparatus.

Whatever success may ultimately attend the ammonia process, it is certain that it can only have a limited

application, unless other sources of ammonia are discovered and rendered available. In any case it cannot supersede Leblanc's, for the strength of this process not only consists in its wide existence, but the various bye-products have by their utilisation become such important articles of commerce, that if not made in the present way, they must be made in some other way. At the same time the fact remains that there is not only room for improvement in this process, but that the desideratum of the day, is a process which shall furnish in one, soda and chlorine, or soda and hydrochloric acid.

In the meantime we would direct attention to a new process for making soda and phosphate of soda, patented and worked out by Mr. G. E. Davis, of Manchester, which is the more interesting inasmuch as it avoids the nuisance arising from alkali waste.

It has for one of its objects, the utilisation of the several phosphates of alumina in such a way that both the alumina and the phosphoric acid are gained, caustic soda being produced as a bye-product, or if the caustic soda be made the principal manufacture, the phosphate of lime and the aluminous residue will be the bye-products; and as the process is one which is likely to receive the attention of manufacturers, manufacturing as it does soda without the production of a noxious waste, we give our readers a description of the process.

A mixture is made of phosphate of alumina, sand, salt-cake, and slack, all in the state of powder, and the mass heated in an ordinary black ash furnace until the decomposition is complete, which happens in rather less time than with an ordinary black ash ball, as the mixture only requires heating to strong redness, and need not be

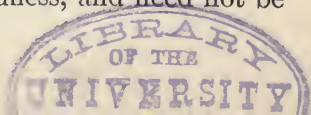

in any way fluxed; indeed, it is almost impossible to flux a charge in any ordinary length of time. When the decomposition is complete, the charge is drawn into an iron bogie, and even without cooling is ready for the operation of lixiviation.

The best form of sand to use for this process is that which comes from the grinding and polishing of plate glass, which, being a waste product, costs the glass-works a large sum of money annually to remove.

The sulphurous acid arising from the decomposition of the salt-cake escapes from the furnace, and may be utilised for the production of salt-cake by Hargreave's process, or in the manufacture of sulphites, by performing the heating of the charge in what is known as a close roaster; if the gas be not required, the charge may be heated in an ordinary furnace or revolver. Several charges worked on the large scale in an ordinary hand black ash furnace were compounded as follows:—

Phosphate of alumina	1.5 cwt.
Salt-cake	2.75 „
Waste sand	0.75 „
Slack	0.75 „

Each charge was worked and drawn in less than an hour, and was so thoroughly decomposed that only traces of phosphate of alumina were found in the insoluble portion.

The chief reaction which takes place, is the formation of a double silicate of alumina and soda, and the soluble tribasic phosphate of soda. The reaction may probably be represented as follows:—

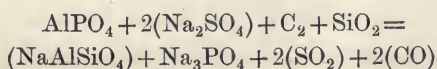

After leaving the furnace, the mass is lixiviated in the ordinary vats used in the alkali manufacture, and a solution of tribasic phosphate of soda is easily obtained. The insoluble residue remaining behind, consisting of the double insoluble silicate of alumina and soda, and containing also a little sulphide of iron, free sand and cinders from the slack used, is very easily washed, and is very coarse and open in whatever way it is manipulated. It has absolutely no smell, and no smell is eliminated in whatever atmosphere it is placed or kept.

The solution, or as we may term it the vat-liquor, is a solution of tri-sodic phosphate, which may be easily converted into the ordinary or rhombic phosphate by the addition of phosphoric acid, thus—



which may be purified by recrystallisation. Caustic soda is made by acting on the vat-liquor with quicklime, when the following reaction takes place—

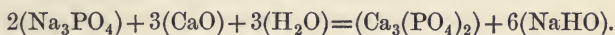

The causticising of a phosphate liquor can take place at higher densities than in the present process, thereby saving much fuel. The lime-mud in this case is no nuisance; it is a phosphate of lime of great purity, and only requires partially drying to make it fit for the market, where it will fetch, as an 80 per cent. article, about 6*l.* per ton. After causticising, the liquor is worked in just the same way as hitherto, that is to say, evaporated, the salts fished out, and the caustic soda carried to cream or fusion. Carbonate of soda is made by acting upon the tribasic phosphate of soda with powdered chalk, thus—

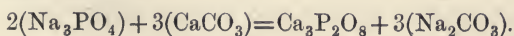

The insoluble residue, which has been mentioned before as not being in any way noxious, may be piled in heaps, and the sulphide of iron allowed to oxidise, after which the copperas may be washed out, and the iron-free residue used for alum making, or other applications, such as sewage precipitation, etc. It dissolves easily in all the dilute acids, forming salts of alumina and soda, and gelatinous silica.

Thus it will be seen that this process deserves the earnest attention of manufacturers, for not only may it produce soda, at a cheaper rate than hitherto, but there is no noxious waste to deposit, and what waste there is, may be used up profitably. The process may be carried on in any alkali works without any change of plant; and as far as we know at present, it is the only feasible process for making alkali, which both *prevents the formation of a noxious waste and the recovery of nearly the whole of the sulphur*. The process, moreover, as one for producing phosphate of soda, contrasts favourably with the method at present in practice. This is as follows:—Coprolites are ground to powder and stirred with sulphuric acid of 28° Tw.; the sulphate of calcium so formed is allowed to deposit, and the supernatant liquors are drawn off, neutralised by the addition of soda ash, and crystallised. The product on recrystallisation gives commercial phosphate of sodium.

CHAPTER XI.

MANUFACTURE OF SOAP.

THE history of the soda trade would be imperfectly described, did we not bestow some attention on the application of caustic soda to soap making. In this place we shall give only a few historical notes regarding this manufacture, and the salient features of the process, referring our readers for full descriptions to the admirable treatises already existing.

According to Rodwell, soap is first mentioned by Pliny, who declared it to be a Gallic invention, and at that time best prepared in Germany. Pliny seems also to have distinguished between hard and soft soap, and was acquainted with the mode of its preparation from wood ashes (beech tree) and goat's tallow. Rodwell says it was used solely as a kind of pomatum, while for cleansing purposes the Greeks added wood ashes (containing carbonate of soda) to the water. This would likewise be inferred from Scripture references, as, for instance, 'Though thou wash thee with nitre and take much soap, yet thine iniquity is marked before me.' (Jeremiah ii. 22). Ætius, a Christian medical writer, about the end of the fourth century, speaks of a black soap, and Paulus Ægineta, a Greek physician in the early part of the seventh century, says he made an extemporaneous soap from oil and the burned dregs of

wine. We have already pointed out that in the ruins of Pompeii, a soap-boiler's shop, containing soap, was discovered and excavated.

In 1795 the Committee of Public Safety in France, engaged Darcet, Lelièvre, and Pelletier to investigate the nature of the art of soap-making, and to supplement their studies by devising improved processes founded on chemical knowledge. In this way many improvements were introduced into the trade, but in those days, as we have seen, the chief sources of soda were kelp and barilla, which were impure forms of sodium carbonate. Before the soap-maker could use these preparations, they had to be dissolved in water and causticised by lime. This was done by the soap-maker himself until caustic soda became a manufactured product, and even now, in many cases, the soap-maker purchases soda ash and causticises it himself. Pearlashes and American potashes are used for making soft soaps, while for the manufacture of hard soap, caustic soda is employed.

Before proceeding to the description of the manufacture, it will be well to understand, in the first place, what is meant by the term 'soap.' In chemical language a soap is a salt of a fatty acid, but for a soap to admit of use as a cleansing agent, it must be one which is soluble in water, and, to an extent, decomposable by it. Such soaps are those having potassium, sodium, and ammonia as their bases, but the two former are the ones which are made on a large scale.

Fats and fixed oils constitute the sources from which the fatty acids are derived; these do not exist in the free state, but in combination with glycerine. To understand this clearly, it may be stated that glycerine is a

triatomic alcohol, $C_3H_5(HO)_3$, or it may be viewed as a triacid base, and as it exists in fats and fixed oils, the hydroxyls are replaced by the radicals of fatty acids; thus, with stearic acid we have the compound

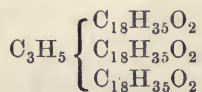

Similar compounds, or fats, are formed by glyceryl and the radicals of palmitic, margaric and oleic acids, etc., and the reaction by which they are produced may be exemplified as follows:—

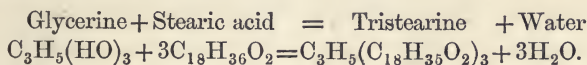

In butter, a fat occurs which may be termed tributyrine $C_3H_5(C_4H_7O_2)_3$; the fats occurring in the human body and in animal food are tripalmitine $C_3H_5(C_{16}H_{31}O_2)_3$, and tristearine $C_3H_5(C_{18}H_{35}O_2)_3$. Trioleine, a more fluid fat abounds in the oils extracted from the lower animals and vegetable seeds; its formula is $C_3H_5(C_{18}H_{33}O_2)_3$. The residues from these vegetable matters are known as oil-cakes, and they are largely used for cattle feeding.

Now when these fats or fixed oils are melted and boiled with caustic alkali, a reaction takes place, which may be represented by the following example:—

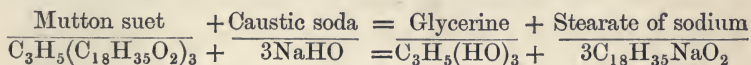

that is to say, the fat is decomposed by the caustic alkali, giving, in the instance we have adduced, glycerine and stearate of sodium. The process itself is called 'saponification,' the product is 'soap,' while the glycerine is a bye-product. This glycerine is for the most part thrown

away, but a considerable quantity is made pure and used for the manufacture of nitro-glycerine.

Soaps are known as hard, soft, or silicated. Hard soaps result from the use of soda, while soft soaps are produced by using potash; of silicated soaps we shall have more to say anon.

Hard Soaps are manufactured from tallow, palm oil, cocoa-nut oil, resin, etc., by saponification with caustic soda.

It will be well here to point out that the consistence of a neutral fat depends upon the predominance of olein or stearin, the first of these bodies being liquid and the second solid.

The pans in which the saponification is effected vary in size, some being 15 feet in diameter and 15 feet deep, capable of yielding 25 to 30 tons of finished soap in one operation. They are constructed of wrought-iron plates, which are riveted together and heated either by a steam pipe immersed in the contents, or by a steam jacket, or by fire. The manufacturer charges his pan with neutral fat or oil, and adds caustic lye of 1.05 specific gravity, boils and stirs. This produces a milky emulsion, to which are added fresh quantities of soda lye, each portion being stronger than the preceding one, until there is free alkali present. These processes are repeated until the pan is filled, but finally the alkali must not be in excess.

Common salt is now added in the proportion of 10 lb. to every 100 lb. of fatty matter used, with the view of salting out (or rendering insoluble) the soap produced, which thereupon floats in granules.

The spent lye is next drawn off and discharged, while the soapy mass is boiled with fresh weak lyes. This

operation gives a homogeneous mixture, which is allowed to remain quiescent for a few hours, after which it is solidified in rectangular frames of cast-iron plates, and after four to five days, when hardened, it is cut by wires into slabs or bars.

Soft Soaps are made chiefly from whale, seal, and linseed oils, tallow and resin, in this country; while on the Continent, hemp, linseed, and poppy oils (drying oils), rape and train oils are largely employed.

These are saponified by potash lyes until a streaky appearance is observed, after which the product is clarified by stronger lyes, till it presents itself as a transparent slime; much of the water is evaporated off, and the boiling continued, meanwhile stirring with sticks until it 'talks.' It is then packed in casks as a deliquescent paste.

Soap from Resin is obtained both as hard and soft, according to the process employed. Resin itself is a mixture of pinic and sylvic acids, together with colophonic acid; these are highly oxidised products of turpentine, and considerable quantities are obtained as a residue in the distillation of turpentine.

The resin is first purified and decolourised by distillation in a current of steam, after which it may be used alone, or mixed with fats. The production of soap from resin is easily explained, resin soaps being simply the alkaline salts of the acids contained in resin. These acids are capable of decomposing sodic carbonate. In short, a soap may be said to be commercially *a body which, on treatment with water, liberates alkali*. This is effected with ordinary soaps as follows:—The water decomposes the neutral sodic or potassic salt into free alkali and acid

salt, which latter, being insoluble, is precipitated as 'suds' while the alkali goes into solution, and by its action upon fatty impurities, effects the cleansing which is desired. This is not at all difficult to comprehend, if it be borne in mind that soap is a polybasic salt, capable of resolution into a less basic or more acid salt, and free base.

Soap from Yolk of Eggs.—Richardson and Watts state that in the print-works of Alsace, there are consumed annually 125,000 kilogrammes of dry albumen, and one kilogramme requires the whites of 28 eggs. The yolks are now used for soap-making as well as for other purposes. To understand the production of soap from the yolk of eggs, we must look into its chemistry.

Besides the olein contained in the free state, there is present a body called lecithine, of formula $C_{42}H_{84}NPO_9$. Gobley, Diakonow, Strecker, Thudichum, and Kingzett have studied this substance, and express its chemolysis as follows:—

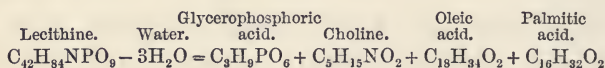

That is to say, bases have the power, by abstracting water, to split up lecithine into, among other products, oleic and margoric acid; so that when eggs are used for soap-making, this process actually occurs, the soda or potash employed, being sufficient to effect the necessary decomposition, and the resulting soap being therefore the product from not only the olein, but from the fatty acids so formed.

Mottled Soaps are produced spontaneously, or by adding to the nearly finished soap, crude soda liquor containing sulphide, through a watering spout. On descending through the pasty mass, any iron that may be present,

is seized and precipitated in veins, thus presenting in the soap the appearance of marble. Or, instead of this proceeding, a slight addition of prussian-blue is made to the soap. In France, sulphate of iron is added during the boiling, by which means ferrous oxide is first formed, and this rapidly peroxidises and gives rise to the mottled character in a great degree. Mottling is simply a trade practice, and serves no useful purpose.

Hard Soaps, when genuine, have the following composition:—In the case of mottled soap, 20 per cent. water; in white, equal 25 per cent.; and in yellow, 30 per cent. together with 8 to 9 per cent. alkaline bases, and 60 to 70 per cent. of fat acids. (Richardson and Watts.)

Soft Soap is generally used for 'fulling' and for cleansing and scouring woollen stuffs. It has a composition which is expressed by the following analyses given by Richardson and Watts:—

Analyses of soft soaps	1	2
Fatty acid	50·0	40·0
Potash	11·5	9·5
Water	38·5	50·5

Silicated Soaps.—We have remarked that, commercially, a soap is not necessarily the alkaline salt of a fatty acid, but a salt of an alkaline base, giving with water free alkali. We may, therefore, in the future, look forward to the extension of the soap trade in fresh directions, as chemical laws may dictate. Already the manufacture of silicated soap in the hands of Mr. Gossage has assumed a most important magnitude.

Silicate of soda (or soluble glass) is known, like soap,

to hold its alkali in but feeble combination, and it possesses considerable detergent power. When mixed with ordinary soap, it forms a mixed soap of greatly reduced price, which is very useful both for domestic and manufacturing purposes.

For hard soap, Mr. Gossage melts in a reverberatory furnace nine parts of soda ash containing 50 per cent. caustic soda, with eleven parts of clean sand; and for soft soap, equal weights of carbonate of potash and sand. These products are dissolved by suitable processes, and mixed mechanically with soap paste, forming the so-called 'silicated soaps.'

Illustrative of the imperfect knowledge possessed by many manufacturers, we may relate here an appropriate case. A Lancashire soap-maker, aware that Mr. Gossage bought sand for soap-making, also determined to buy some, but when he had purchased it he was at a loss to know how to use it, and in consequence mixed the sand with his soap paste!

Thus far we have attempted to indicate the steps in the processes of soap-making, but the chapter is necessarily little more than an indication of the various plans and processes now in use. In conclusion, we give here some statistics relative to the soap trade.

In the year in which the duty on soap was abolished (1852), the total production of soap in Great Britain was equal to 1,600 tons per week, 'less than one-half of which was produced in Lancashire' (Gossage). In 1860, no less than 9,749 tons were exported, but the export trade has fallen off since. In the year 1870 the production of soap in the Lancashire district alone, amounted to the total production of 1852; therefore, to 1870, it had

increased 50 per cent. (Gossage). The following figures are taken from McCulloch's Dictionary, and show the quantities of soap produced in England and Scotland :—

YEAR ENDING JANUARY 5, 1872.

Kind of soap	England	Scotland
Silicated	lb. 1,320,033	lb. 7,150
Hard	169,519,201	15,206,064
Soft	11,874,932	7,150,119
	182,714,166	22,363,333

CHAPTER XII.

HISTORICAL NOTES ON THE BLEACHING INDUSTRY.

MR. PARKES, in his 'Chemical Essays,' gives some interesting observations on the history of bleaching. He records that Pliny wrote, 'Of late days there were seen in the amphitheatres of the Emperor Nero, fine curtains of blue azure colour like the sky, and the very floor of the ground under men's feet was coloured red. But for all these paintings and rich dyes, yet, when all is done, the white linen held the pre-eminence still, and was highly esteemed above all colours.' Pliny likewise records that the Gauls and Britons of his time were acquainted with a mode of bleaching linen cloth, by pounding the woven yarn in water, and beating it upon a smooth stone with broad-headed cudgels; he also tells us that 'the Faventine cloth is always far whiter than the Allian, which is ordinarily brown when it is new woven and before it is bleached.' Theophrastus (son of a fuller in the Isle of Lesbos, 300 B.C.) relates that lime was then employed in bleaching; moreover, there are numerous allusions in Scripture to fine linen white and clean. The ancients employed sulphurous acid for bleaching purposes.

Passing from these very ancient times to modern ones, we find that, in 1803 (according to Mr. Henry Ashworth), the charge for bleaching a well-known description

of cloth was 7s. 6d. for a piece of 28 yards ; such a piece would now cost less than 6d. for bleaching. Half a century ago, the linen from Holland was the most esteemed, owing to the superior skill there employed in the operations of bleaching. Generally, the process employed at and before that time may be thus described :—The goods were steeped in water, or hot dilute alkaline lyes, after which they were *boiled* in similar solutions, which operation was known as ‘bucking.’ This done, the goods were exposed to the air on the grass (crofting), and after they had been exposed sufficiently long they were immersed in sour milk (souring), and the whole of the operations repeated as often as was necessary. Sometimes these operations extended over a period of six, seven, or even eighteen months.

But an improvement was near at hand, and consisted in the employment of sulphuric acid in the place of sour milk. Although the manufacture of sulphuric acid was first successfully introduced by Dr. Roebuck, as we have already shown, the application of it to bleaching purposes was the proposition of Dr. Home. In this way, the time required for the above operations was reduced to four months or so. In 1774, the Swedish chemist, Scheele, in experimenting on the action of marine (hydrochloric) acid upon native manganese, discovered the green gas chlorine, and he himself afterwards ascertained its power of destroying vegetable colours, either when employed as a gas, or in the form of an aqueous solution. Davy, in 1810, proved its elemental character, and changed its name from oxy-muriatic acid to chlorine. Berthollet, in 1785, advocated its employment in the art of bleaching, and not only so, but he described experiments illustrative

of the bleaching character of chlorine on pronounced vegetable colours.

To understand this bleaching action, it must be stated, that it is dependent on the decomposition of water by the chlorine, which liberates nascent oxygen, and this is what really effects the bleaching. Indigo blue, in the presence of water, is destroyed by chlorine with the formation of a soluble orange-red non-tinctorial principle, viz. Isatin, thus—

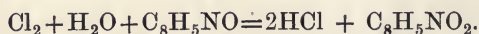

‘Thus bleaching by the action of chlorine, like bleaching by exposure to air, is really an act of oxidation’ (Odling).

About the end of July, 1787, the first actual application of chlorine to bleaching was effected by Messrs. Milnes and Messrs. Gordon, Barrow, and Co., of Aberdeen, on the information given by Professor Copland and the Duke of Gordon, who gained their knowledge on the Continent. Mr. Watt, the engineer, on the invitation of Berthollet, witnessed his experiments about the same time, and he communicated the results to his relative, Mr. MacGregor, of Glasgow, who continued the experiments, and used the process. But, after some experience, it became important to protect the fibre of the material to be bleached, from the corrosive action of chlorine itself and the hydrochloric acid which is produced simultaneously with the act of bleaching.

This, and the injurious action of the chlorine upon the workmen, led to the use of ‘lye of Javelle,’ which was introduced from Javelle, near Paris, where it was originally made in 1792, and which was really hypochlorite

of potassium. But this was destined to give way, after some extended use, to Mr. Tennant's patent of 1798, in which a solution of hypochlorite of calcium was used, although Dr. Henry appears to have first used lime. Mr. Tennant shortly afterwards lost the right of patent, but in 1799 he introduced the use of bleaching powder. Bleaching powder is still used in vast quantities, its manufacture having greatly developed since the introduction of straw, Esparto grass, etc., in addition to rags, for the manufacture of paper.

The further history of bleaching powder relates to the improvements in the manufacture of chlorine used in its preparation. These will be described in detail in further chapters. Here we shall merely give the rationale of the process of bleaching.

In the case of calico, the fabric is well washed and boiled successively with lime-water, much dilute sulphuric acid, and weak caustic soda, to remove the weavers' dressing, greasy and resinous matters, etc. It is then well washed and digested in a 2 to 2½ per cent. solution of bleaching powder, after which it undergoes an immersion in very dilute sulphuric acid, which liberates chlorine within the fibres, and thus removes the colour *in situ*. But even now it is not perfectly white, and is therefore washed and again steeped in an alkaline lye, to remove the colouring matter rendered soluble by the chlorine. It is then again passed through weaker solutions of bleaching powder and dilute acid successively, and finally thoroughly washed in copious streams of water, to effectually remove the sulphuric acid, which would otherwise destroy the fibre.

Bleaching powder presents a great facility of manage-

ment and capability of being used in different ways, so much so, that the great development of the manufacture is considerably due to these causes.

Now let us pause for a time to consider the constitution of bleaching powder, and the probable manufacture in the future of that principle in it in which rests its whole power of bleaching.

Bleaching powder, then, has, by the researches of Gay-Lussac, Kolb, Kingzett, and others, been proved to be a compound of hypochlorite and chloride of calcium, represented by a formula first assigned to it by Odling,

Ca $\left\{ \begin{array}{l} \text{Cl} \\ \text{OCl} \end{array} \right.$; but the combination is so feeble that, under

certain conditions, water destroys the compound from a chemical whole into the two salts. Till quite recently, however, the true hypochlorite of calcium was unknown in the solid pure state, but the author has succeeded in the isolation of the hypochlorite from bleaching powder, thus still more clearly establishing the constitution of bleaching powder.

Bleaching powder as we know it in commerce, is a mixture of the above principle, with a great excess of lime, and contains about 35 to 38 per cent. chlorine. For bleaching purposes, the excess of lime is valueless, so also is any excess of chloride that may be present, and also that amount of chlorine which enters as chloride into the compound molecule. That is to say, the bleaching power may be said to reside in the hypochlorite of calcium only; so that if it were possible to manufacture pure calcic hypochlorite, its use would supersede that of 'bleach,' among other reasons, because (1) it is entirely and easily soluble in water, and (2) it

possesses the total bleaching power of the powder in a much less volume.

In a following chapter we shall point out how, in the future, the manufacture may be possibly conducted in this way. As we have already shown, 'bleach' must, before being used, be dissolved in water; but as by the passage of chlorine into milk of lime there is obtained a product richer in chlorine than the powder, bleaching liquor continued to be produced and used for some time after the invention of the powder. The objection to it, lies in its anti-portable nature, and this objection was more serious in those days than now, because even the action of chlorine upon milk of lime (except under limited conditions) was unknown, and if excess of chlorine happened to be used, free hypochlorous acid was produced, and thus a product obtained, which is liable to explode spontaneously; but if the action of chlorine be limited in the manner to be hereafter described, this danger is avoided.

CHAPTER XIII.

OLD PROCESSES OF MANUFACTURING CHLORINE.

IN a previous chapter we have described the manufacture of hydrochloric acid as a bye-product obtained in the conversion of salt into sulphate of sodium, together with the means of condensation employed and the working results.

Let us now consider this hydrochloric acid as a source of chlorine, for the production of bleaching powder and chlorate of potassium. These, however, are not the only manufactures in which hydrochloric acid is found useful. It is used by bleachers for decomposing the lime soap formed by boiling greasy fabrics with lime, the fatty acids so liberated being removed by alkali. The dyer also employs it for making chloride of tin, and it is largely used as a solvent for the phosphatic constituents of bone during the manufacture of gelatin. We might easily extend this list of the uses of hydrochloric acid, but we will simply add that in some alkali works, hydrochloric acid is employed to generate carbonic acid from limestone, to make bicarbonate of sodium.

We shall first describe the manufacture of chlorine as carried out on the largest scale, prior to the introduction of Mr. Weldon's first process, after which we shall describe Dunlop's, Shank's, and other processes which were either actually in work to a greater or smaller extent, or have

been only suggested. Ever since the discovery of chlorine by Scheele, by the action of muriatic acid upon peroxide of manganese, that method has been the one in use on the largest scale for the manufacture of chlorine.

The manganese ores employed, are derived chiefly from Germany, Spain, France, Belgium, and Holland, and small quantities are produced in England and America. 'Pyrolusite' is the most abundant of these ores, and one of the richest in oxygen, containing from 80 to 87 per cent. red oxide of manganese, and 10 to 14 per cent. oxygen. This is important to bear in mind, because the generation of chlorine depends essentially upon the seizure of the hydrogen of the hydrochloric acid, by the excess of oxygen in the pyrolusite, to the formation of water, with the liberation of the chlorine. The ores used in commerce generally contain from 60 to 75 per cent. in terms of MnO_2 (peroxide of manganese).

In the early days of the trade, our chief supplies came from Devonshire, then Germany and Belgium fed the demand; but of late years the best qualities and chief quantities have been imported from Spain. Richardson and Watts, in their work, tell us that the total production of manganese ores in Germany amounted in 1857 to 895,666 centner (mostly from Nassau), and that Spain produced annually 500,000 centner. Muspratt, in his Dictionary, states the total consumption in this country to be about 25,000 tons annually, of which from 17,000 to 18,000 tons were in his days, used in the manufacture of bleaching powder. For 1858, Ure gives our total import of manganese as 24,171 tons.

The chlorine was originally produced from a mixture of salt, manganese and sulphuric acid, heated in a leaden

apparatus on a water bath. The proportions used in 1800 were as under :—Vitriol, 4 ; manganese, 2 ; water, 4 ; salt, $4\frac{1}{2}$. (Mactear.)

Up to 1815 an excise duty of 30% per ton was laid upon the waste products from bleaching powder stills (Clapham), but after that date, the sulphate of sodium contained in the residuum was extracted and used for alkali making. Eventually the use of salt in admixture with the manganese ore was abandoned, and the latter used alone. For the reaction, bitubulated stoneware carboys were used, but these gave way many years ago to perforated stoneware cylinders ; then came cast-iron vessels lined with lead, and eventually a more recent kind of still, which was sometimes hewn out of the solid stone.

The most recent kind of still (as used in the Weldon process) is, therefore, the perfected form of an apparatus which, though very crude originally, has undergone improvements in construction, partly by Lee and Pattinson (1846), and finally by Weldon. These stills are now constructed of Yorkshire flagstones, being square in build, and of about 5 to 6 feet. The joints are rendered air-tight by means of indiarubber rods supplemented by Chinese clay and tar, and the whole girded strongly together by iron bands. They are provided with a manhole, large enough to admit a man, for cleansing purposes ; and there are also two taps, a smaller one for testing purposes, and a large one near the bottom for drawing off the residual liquors. The stills are further fitted with a false bottom of stone, 5 to 10 inches from the true bottom, on which (in the case of ore) the charge of manganese is laid—400 to 800 lb. manganese ore.

The hydrochloric acid, which is usually stored in a

cistern above and near the still, is run into the still through an indiarubber pipe, passing into a hole just large enough to admit it. There is also another small hole for gauging the contents, and in one corner of the still, which is partitioned off by stone, enters the steam pipe for heating purposes.

Originally, these stills were not uncommonly heated by fire, but explosions often occurred, and led to the disuse of fire; moreover, in the Weldon process steam answers thoroughly well, the regenerated manganese being so much more soluble than the ore. The chlorine is led away by an earthenware pipe in communication with a cistern of water which serves the purpose of washing the gas, which then passes on through lead pipes for the chamber use.

The chemical reaction which occurs in the stills is as follows :—



That is to say, one half of the total chlorine was originally lost (for the residual liquors were thrown away) as chloride of manganese. Not only so, it was impossible to entirely neutralise the whole of the hydrochloric acid, in this way.

These facts led manufacturers to make what use they could of these residual liquors. We have seen that they were used to decompose alkali waste, for instance. Further attempts were made from time to time to regenerate at least the manganese contained in them, while other efforts were directed to substitute entirely different processes. From the many proposed methods we shall select a few for description.

Mr. Elliott attempted the regeneration of the manga-

nese by evaporating the liquors left in the still, to dryness, and roasting the residue in a current of steam. The hydrochloric acid so formed being condensed, the residue consisted of a mixture of protoxide and peroxide of manganese, which was destined for use in the still again :—



Others precipitated the manganese from the liquors as protoxide by means of lime or other bases, and exposed the product to a red heat with access of air, thus producing a more or less highly oxidised manganese ; but all these plans failed commercially on a manufacturing scale, depending as they did in great measure on the relative cost of coal and manganese ores. Moreover, it is impossible to get above a certain state of oxidation under the given circumstances, and, after all, the value of a regenerated manganese depends, like the ore, upon its state of oxidation—the greater the amount of oxygen it contains, the more valuable it is.

Dunlop's process, however, succeeded better than any other, and indeed, Messrs. Tennant have from the time when the process was first introduced, utilised the whole of their residual still liquors by this method. The great drawback to the process lies in the costly apparatus required ; but when once this is erected, Mr. Mactear considers it to be even now the best process of the day in so far as cost and yield of bleach are concerned.

The difficulty we have named, and the high price of coal on the Continent, have militated against its general adoption.

The process, which is still worked at St. Rollox, is as follows :—The liquors are first freed from ferric oxide,

alumina and silica, by the addition of a little milk of lime, after which they are mixed with finely-divided chalk, which reacts on the manganese chloride as follows:—



This reaction, by the aid of steam under pressure and heat, is completed in about four hours in boilers. The chloride of calcium liquors are then run off, and the precipitated carbonate of manganese is washed and drained.

The next operation, which is one of the most beautiful in the whole range of industrial chemistry, has for its object the expulsion of the carbonic acid and oxidation of the manganese. For this purpose the carbonate is drawn through a furnace in small waggons, in much the same way as glass is annealed. Each furnace holds about forty-eight of these waggons, and is worked at an average temperature of $315^\circ \text{C}.$; in forty-eight hours all the water and carbonic acid are evolved, leaving a product of about the composition represented by $2\text{MnO}_2 + \text{MnO}$.

M. Laurens proposed to obtain chlorine from cupric chloride by mixing it with sand and heating the perfectly dry mixture in retorts or cylinders of iron lined with clay and charcoal, when at a strong heat cuprous chloride forms and chlorine is simultaneously evolved. From the cuprous chloride the cupric salt is again made, by exposure to air and hydrochloric acid, and the resulting solution, after evaporation to dryness, undergoes once more the primary reaction. Thus we have—

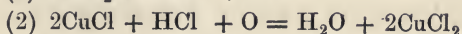

Mr. Gatty had previously proposed and examined this

process in England, and in Germany M. Vogel did the same, while the last-named observer states that the cupric chloride in this way loses only one-third of its total chlorine. Copper is so expensive (some loss is inevitable), and so great is the wear and tear on the plant, that these objections, considering also the danger arising to the workmen from the fine copper dust, have proved insurmountable.

Dr. Gerland and Mr. E. Muspratt obtained cobalt and nickel sulphides from manganese liquors, by means of alkali waste liquors, thus utilising in some degree the soluble sulphides of calcium contained therein.

Mr. Shank devised a chlorine process which was practically worked in St. Helens, and, in fact, at the date of Messrs. Roseoe, Smith, and Schenck's report the British Association in 1871, was still in operation. In this process chromate of lime is decomposed in the stills with hydrochloric acid, when the following reaction occurs:—

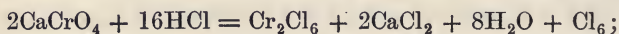

giving a steady supply of chlorine, the last portions being expelled by steam-heating. The residual liquors containing chlorides of calcium and chromium, are diluted with hot water, and neutralised with milk of lime; more milk of lime is now added, first in quantity necessary for the precipitation of the sesquioxide of chromium, and afterwards a further quantity, sufficient for combination with the chromic acid formed in the next operation. The liquors are settled, and the chloride of calcium solution decanted. The sludge is drained, and when stiff, is thrown into a close furnace maintained at low redness, air meanwhile being admitted through apertures, when

the whole mass is transformed into chromate of lime, ready for use over again. One of the greatest objections to this process is the enormous waste of hydrochloric acid involved.

Another process, known as Dunlop's, has also been in actual use at St. Rollox since it was first proposed. It consists in decomposing a mixture of nitrate (Chilian or soda nitre) and chloride of sodium in cast-iron cylinders by means of sulphuric acid. The gaseous products are made to pass through leaden Woulff's bottles containing sulphuric acid to a depth of 24 inches, this great pressure being necessary to moderate the action in the cylinders. Each cylinder takes 12 cwt. of nitre, and sufficient sulphuric acid of 120° Tw. is used to form the bisulphate of soda:— $2\text{NaCl} + \text{NaNO}_3 + 3\text{H}_2\text{SO}_4 = 3\text{NaHSO}_4 + \text{Cl}_2 + 3\text{H}_2\text{O} + \text{NO}_2$ (nitrous acid), which is run off as a liquid into a furnace containing common salt, thus producing salt-cake and hydrochloric acid. The charges are worked off in thirty-six hours at a temperature of 400° to 500° Fahr. The nitrous acid is absorbed by the sulphuric acid in the condensers, and the hydrochloric acid is condensed, while the chlorine goes to the chambers. The nitrous sulphuric acid is employed in the production of chamber acid.

Mr. Dunlop also suggested the expulsion of the nitrous compounds by heat, into a chamber where they meet with a current of sulphuretted hydrogen, giving rise to sulphate of ammonium and sulphur—



There have been proposed several other processes, alike in many respects to this one of Dunlop. They may

be expressed as follows:—Hydrochloric acid is decomposed by nitric acid, giving a lower oxidised form of nitrogen and chlorine. The nitrogen compound takes up more oxygen from the air, and the product is again decomposed by hydrochloric acid, and so on indefinitely:—

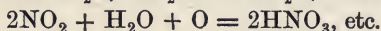
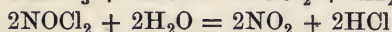
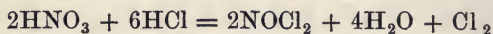

However, the precise reactions occurring have not been established, and would vary, in all probability, with the circumstances under which they occur. Nitric acid is an expensive oxidant, and it would therefore be necessary to thoroughly and cheaply regenerate it.

We have already, in an earlier chapter, alluded to Longmaid's process, which produces chlorine so diluted with air and nitrogen as to be unfit for making bleaching powder above 20 per cent. The same objection applies to Thilbierge's proposition. Thilbierge passed air over heated ferrous chloride (FeCl_2), thus obtaining ferric oxide and chlorine. Recently (British Association, 1870), Mr. Hargreaves, of Widnes, has revived this idea. He has a process for separating phosphoric acid from iron ores and cinders, and in this process the slag is dissolved in hydrochloric acid, in which operation, apart from the main object of the process, the protochloride of iron is obtained. Mr. Hargreaves proposed to deal with this by evaporating it to dryness, and then by heating the dried substance in air at a temperature about the melting point of zinc, to decompose it into the peroxide of iron and free chlorine which was to serve for the production of bleaching powder:—



Thus it will be seen that, if the process worked, not only would the use of manganese be dispensed with, but a given amount of hydrochloric acid would produce double the amount of chlorine that can be obtained by using manganese. But even should this be so, and the reactions be fully realised, the process would be attended by an insuperable difficulty—the treatment of the dilute chlorine produced. Moreover, in these days, when the manganese is regenerated, the process would, by comparison, depreciate in value.

Oxland, in 1845, passed one volume of dry hydrochloric acid gas and two volumes of air through airtight reverberatory furnaces, packed with pumice stone kept at a red heat; and in 1846, Jullion, in a similar plan, substituted asbestos and spongy platinum for the pumice stone. But here again, as in Deacon's process to be presently described, chlorine in a dilute state is obtained.

Maughan, in 1836, first proposed to pass roaster gas (hydrochloric acid) through manganese contained in cylinders heated by steam, the evolved gases being washed in water and the chlorine conveyed to the chambers; and, in 1842, Seybel proposed the same process, only he, moreover, passed his products through water containing manganese in suspension, and kept the manganese in motion.

Tessie de Mothay has a process which is as follows:— Into a retort maintained at a red heat, containing peroxide of manganese, or a mixture of it with lime, a current of hydrochloric acid gas is caused to pass. Chlorine and steam are disengaged, and there remains in the retort, a mixture of undecomposed peroxide of manganese

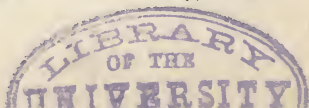

with the chlorides of manganese and calcium. Over the mixture remaining in the retorts, still at the same temperature, air or oxygen is passed, which in the presence of the peroxide is said to decompose the manganic chloride at once.

The chlorine produced in this last operation, is led into vats containing a mixture of lime and protoxide of manganese, which bodies have been previously produced by the decomposition of $MnCl_2$ by lime, the soluble calcic chloride having been run off. In the vats sesquioxide of manganese and calcic hypochlorite result, and these two react, giving peroxide of manganese and calcic chloride.

The product, with fresh hydrochloric acid, yields more chlorine for use in the chambers; or he uses, instead of lime, magnesia. Thus he proposes to constantly regenerate the manganese, and get all his chlorine for the production of dry hypochlorites in the pure undiluted condition.

Some time ago Mr. Deacon secured letters patent for a process which consisted in passing sulphuric anhydride and air over salt at high temperatures:—

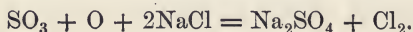

Unfortunately, air having to be employed, necessarily dilutes the chlorine which is produced, with all the nitrogen contained therein, even if no other objections were encountered in attempting to realise the above reaction. If air be omitted, the following reaction would occur:—

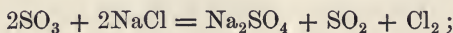

and directly these resulting gases came in contact with

water, there would be formed sulphuric and hydrochloric acids:—

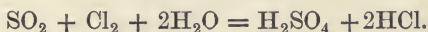

F. de Lalande and M. Prud'homme profess to have generalised this reaction of Deacon's, employing in the place of sulphuric anhydride, silicic, boric, stannic, and phosphoric acids, also alumina. Taking silica, they say that silicate of sodium is formed, together with chlorine, thus:—

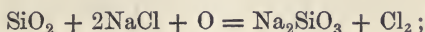

and by passing hydrochloric acid over the residue, they obtain re-formed chloride and free silica, for use again:—

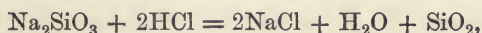

thus obtaining a continuous supply of chlorine. The steam in this last reaction gives rise to two secondary reactions, both of which occur, however, to a very limited extent:—

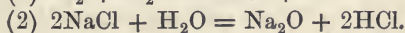
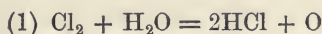

But these methods, so far, are possessed of scientific interest only. In our next chapter we propose to study the process which bears Mr. Weldon's name, and which has proved the most successful industrial process of the day.

CHAPTER XIV.

WELDON'S CHLORINE PROCESS (*a*).

TILL quite recently, the numerous attempts made from time to time to regenerate manganese from the acid liquors of chlorine stills were, as we have seen, mostly unsuccessful, the best of them having achieved a very limited adoption. It remained for Mr. Walter Weldon to successfully revive the spent manganese by effecting its aërial oxidation. The importance of this process is borne out by the fact that, taking the total bleach-make of Great Britain during 1874 at 90,000 tons, more than 50,000 were made by Weldon's process. We are informed that in 1874, twenty-two plants were working this process, and that nearly forty others were in course of erection. It is, moreover, largely at work in Germany, and is employed at the largest works in France and in Belgium. Regarding the capability of the plant, it may be said to be limited only by its size. As much as 230 tons of bleach are made per week at one work.

Incidentally, the process has the advantage of abolishing the discharge of corrosive, acid, manganese liquors into water streams, whereby great damage was often effected. The liquors as they come from the still consist of chloride of manganese, containing small quantities of the sesqui-

chlorides of iron and aluminium, chloride of calcium, and the excess of unneutralised hydrochloric acid. They are run into a well about 7 feet deep, and 20 feet in diameter, provided with an agitator, where they are neutralised by chalk or other forms of carbonate of calcium, thus precipitating the iron and aluminium as oxides, and are afterwards pumped up into the 'settlers.' These settlers are oblong iron tanks, wherein the gypsum and oxides of iron and aluminium deposit, and a clear, pink liquor results; this is drawn off by means of an iron pipe, provided with a piece of gauze at the extremity, to keep back any solid lumps, and which is allowed to dip just beneath the surface of the liquor. As regards this deposit, it may be said that it causes the only unavoidable loss of manganese in the process, for although the deposit is submitted to washing, yet as thrown away, it contains some manganese.

A vessel known as an 'oxidiser' receives the liquors from the settlers. This cylindrical vessel, when of large size, is about 8 to 12 feet in diameter, and 22 to 35 feet deep, constructed of wrought-iron plates, and furnished with two pipes, which go down nearly to the bottom—a large one for conveying a blast of air from a blowing engine, and a smaller one for the injection of steam. The oxidiser is also fitted with an agitator.

The oxidiser, having received a charge of liquor, is heated by steam to somewhere between 150° and 170° Fahr. Sometimes the liquors reach the oxidiser at nearly that temperature. Immediately above the oxidiser is a reservoir containing milk of lime (15 to 20 lb. of the hydrate to the cubic foot), which is run into the hot liquor as rapidly as possible, air being blown in meanwhile. The

addition of the milk of lime is continued until the filtrate, from a sample drawn off at a tap placed near the bottom of the oxidiser, ceases to give a manganese reaction with solution of bleaching powder, that is, a purple colour, due to the formation of permanganate of calcium. A certain further quantity of milk of lime is then added, and the blowing continued till peroxidation ceases, which point is usually attained when from 80 to 85 per cent. of the manganese has become converted into peroxide, an operation lasting two to four hours.

The contents of the oxidiser are now a thin black mud, consisting of chloride of calcium solution, containing in suspension about 2 lb. of peroxide of manganese per cubic foot, being combined with varying quantities of protoxide of manganese and lime. This protoxide of manganese and lime are together known as 'base,' and amounts generally to from $\frac{1}{2}$ to $\frac{3}{4}$ per cent. The mud is now run into a series of 'mud settlers,' or iron settling tanks, where it subsides to about one-half, so that the top clear liquor is drawn off and discharged, while the mud, now containing about 4 lb. of peroxide of manganese to the cubic foot, is ready to be charged into the stills, for a fresh operation. For this purpose, the stills are about half filled with the acid, and the manganese mud run in to the extent of about 500 cubic feet to a charge, at the same time that heating by steam is applied. It takes from two to four hours to work off a still. The reactions representing the various operations may be stated generally as follows:—

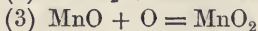
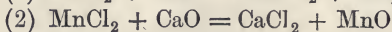
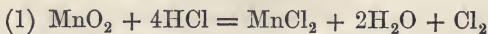

We are enabled, through the personal kindness of

Mr. Walter Weldon, to give here a drawing of his chlorine plant (figs. 21, 22, and 23).

FIG. 21.

- A. Native manganese stills (used for starting the process and for keeping up the supply of manganese, which very slowly decreases owing to a slight loss).
- B. 'Weldon stills,' about 8 feet square and 10 feet deep; acid pipe about 4 feet above the bottom of the stills. These stills are constructed of Yorkshire flagstones, or hard silicious sandstone, and are specially adapted for working up the manganese mud, which is changed through a lute into the still. The new Weldon stills are polygonal in shape, 12 feet across and 7 feet to 8 feet deep.
- C. Space for other stills.
- D. Well in which the still liquors are neutralised (14 feet diameter and 7 feet deep).
- E. Donkey-pump for liquors.
- F. Still liquor settlers (two of wrought iron; 12 feet long and about 6 feet deep).
- G. Oxidiser (8 feet 6 inches diameter and 30 feet deep).
- H. Mud settlers (four of wrought iron; 6 feet deep and 12 feet long).
- I. Vessel in which the milk of lime is prepared (8 feet diameter).
- J. Vessel for holding milk of lime (8 feet diameter and 6 feet in depth).
- K. Boiler (about 30 feet long and 7 feet diameter).
- L. Blowing engine (these are either vertical or horizontal).
- L'. Space for second blowing engine.
- M. Air receiver.
- N. Pump for milk of lime.

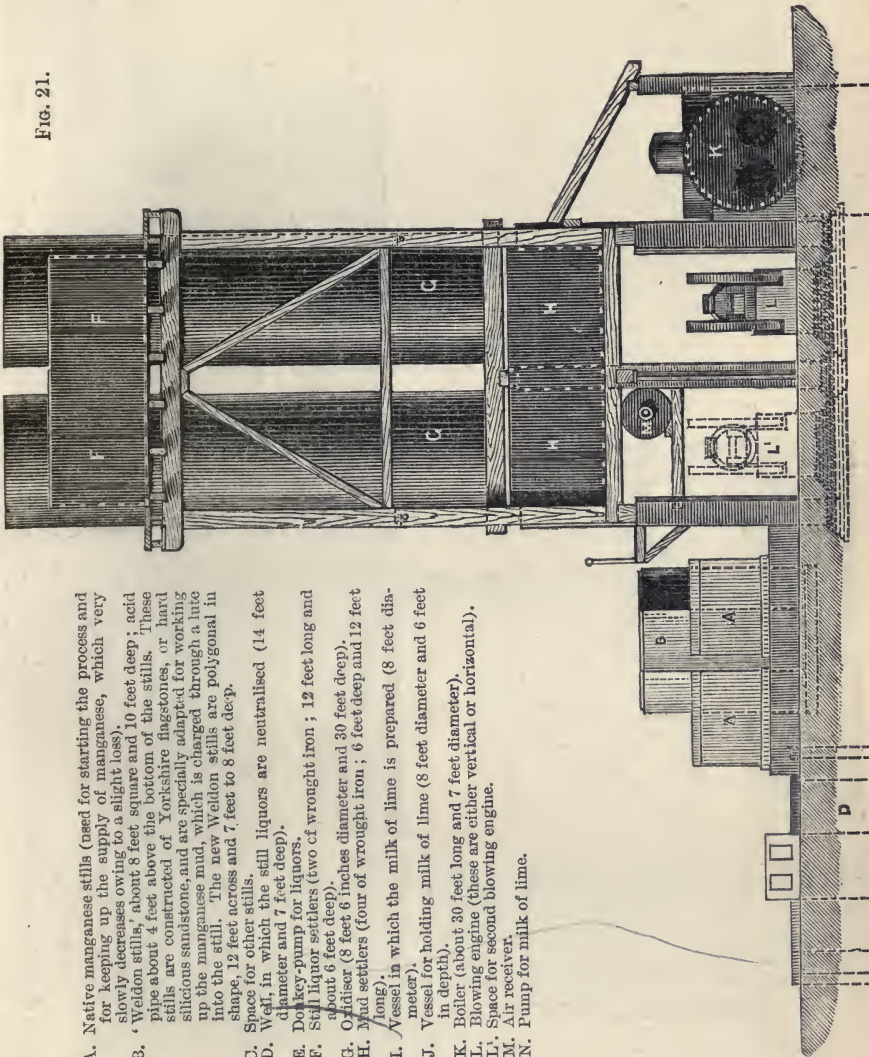
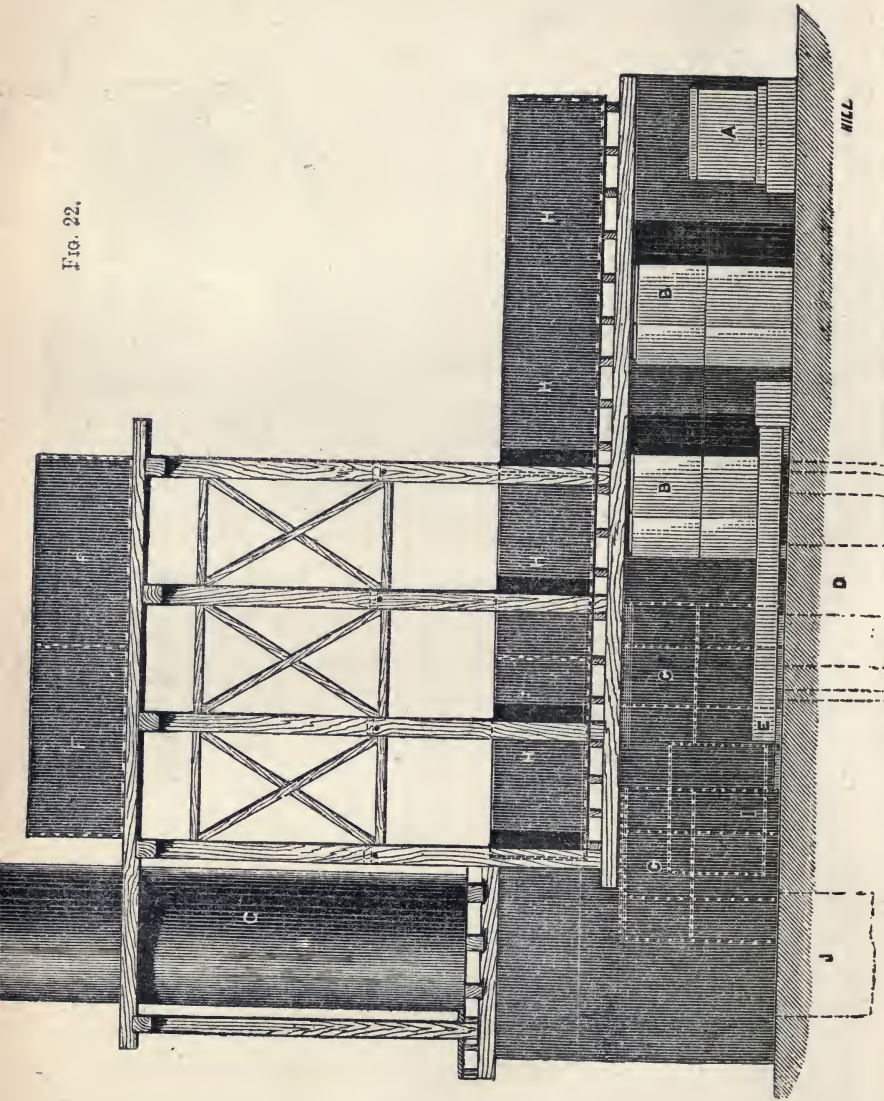
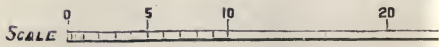
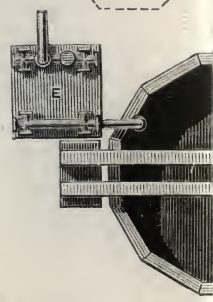
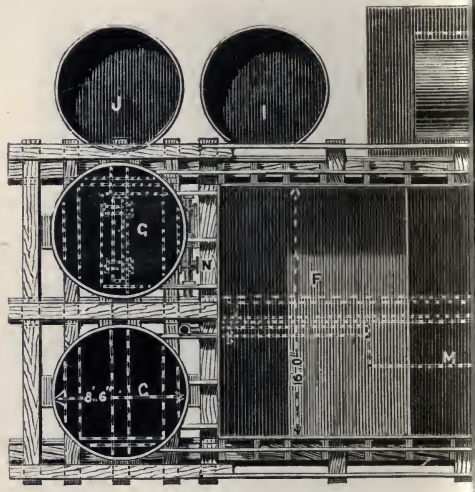
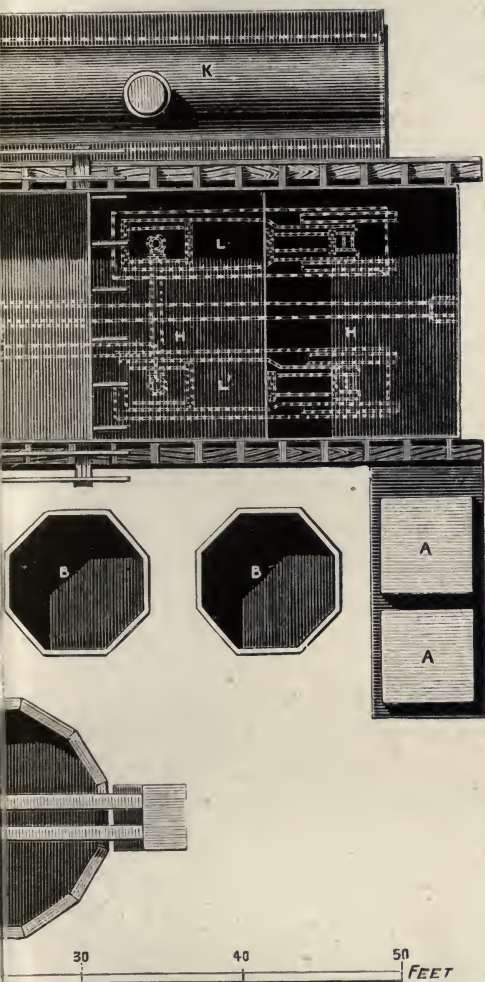

FIG. 22.







GENERATION PLANT (PLAN).

The quantity of lime which it is necessary to employ in the oxidiser varies considerably, because lime dissolves in chloride of calcium, and further, because all parts of the lime do not act equally well—the coarser particles act less rapidly and perfectly. Usually, however, 1.15 to 1.45 equivalents are added before the precipitation of all the manganese is effected, and the further quantity which is added such that the foregoing figures become 1.5 or 1.6 equivalents.

Now, for one moment, let us consider the use of this additional quantity of lime. The precipitation of protoxide of manganese by lime, has for very many years been a well-known fact; in short, it is the excess of lime employed, which constitutes the very secret of Weldon's process, for without that excess, it would be impossible to carry the peroxidation of the manganese to any great extent.

In the presence of an excess of lime, there is not obtained peroxide of manganese but, as Weldon suggests and claims to have demonstrated, various compounds of the peroxide with lime, viz., manganites and sesquimanganites, etc. Thus CaOMnO_2 and CaO_2MnO_2 are obtained, a small portion of the CaO being usually replaced by an equivalent amount of MnO .

The quantity of air required to be blown in, varies with the conditions, chiefly depending upon the depth of the oxidiser—the greater the depth the more rapid the oxidation proceeds. In one instance 175,000 cubic feet of air were blown in, during five hours, and of the oxygen contained in this, 14.8 per cent. (equal to rather more than 4 cwt.) was absorbed in the production of 22 cwt. of peroxide of manganese. (Weldon.) The mechanical

power generally expended in blowing, averages about between seven and eight horse-power for one hour, per 100 lb. of MnO_2 made.

Theoretically, 1,020 lb. of MnO_2 should yield the amount of chlorine contained in 1 ton of bleaching powder per 37 per cent. chlorine, and in practice, 1,100 lb. of MnO_2 are necessary for this production, or rather that amount of mud containing 1,100 lb. MnO_2 . The lime used, is generally prepared like that used for making bleaching powder (see chapter xvii.), and its consumption averages 14 cwt. per ton of bleach. By this process 1 ton of bleach is made, using 2,832 lb. of hydrochloric acid (HCl), generated by the decomposition of 47.5 cwt. of salt, viz., a quantity which theoretically yields 3,334 lb. HCl . There is, therefore, a loss of acid of 15 per cent. The loss of manganese varies from 4 to 10 per cent. The whole of the lime is lost, and two-thirds of the total chlorine (in combination with calcium) contained in the acid used.

The following table is employed in works where Weldon's process is in use, for the estimation of the 'base,' that is the CaO and MnO in the mud.

'As the number of grains of ferrous sulphate ($\text{FeSO}_4 \cdot 7\text{H}_2\text{O}$) peroxidised by the MnO_2 in a given volume of manganite mud, is to the number of grains of oxalic acid ($\text{C}_2\text{H}_2\text{O}_4 \cdot 2\text{H}_2\text{O}$) decomposed and neutralised by the same volume of the mud; so is 100 to a figure in column A against which in column B is the per cent. of bases:—

A				B			
69·00	65·75	62·50	59·25	1·044	·901	·758	·615
68·75	65·50	62·25	59·00	1·033	·890	·747	·604
68·50	65·25	62·00	58·75	1·022	·879	·736	·593
68·25	65·00	61·75	58·50	1·011	·868	·725	·582
68·00	64·75	61·50	58·25	1·000	·857	·714	·571
67·75	64·50	61·25	58·00	·989	·846	·703	·560
67·50	64·25	61·00	57·75	·978	·835	·692	·549
67·25	64·00	60·75	57·50	·967	·824	·681	·538
67·00	63·75	60·50	57·25	·956	·813	·670	·527
66·75	63·50	60·25	57·00	·945	·802	·659	·516
66·50	63·25	60·00	56·75	·934	·791	·648	·505
66·25	63·00	59·75	56·50	·923	·780	·637	·494
66·00	62·75	59·50	56·25	·912	·769	·626	·483

It is of extreme importance to keep down the amount of base in the mud as low as possible, because lime and protoxide of manganese have, of course, no power to generate chlorine from hydrochloric acid, but simply dissolve in it, thus—

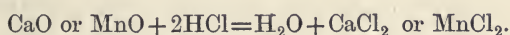

To effect this desideratum it is essential that no more lime should be used in the oxidiser than is absolutely required, because a great excess of lime causes the formation of compounds which do not admit readily of peroxidation. In fact, in many works, a little chloride of manganese solution is now added after the full complement of lime has been charged into the oxidiser.

In relation to Weldon's process, a provisional specification was taken out by Mr. Valentin, of the School of Science. He discovered that ferricyanide of potassium acts as a carrier of oxygen to protoxide of manganese, and he proposed to apply this discovery in industry. For this purpose the still liquors, after neutralisation with lime, are precipitated by a chemical equivalent of lime,

and instead of adding more lime, as is done in Weldon's process, a solution of potassic ferricyanide is added, and air blown through, whereby the protoxide becomes peroxide of manganese, and in much less time than in Weldon's process.

It is probable that the influence of the ferricyanide consists in yielding up its oxygen to the mud, being at the same time reduced to ferrocyanide, and this being reconverted into ferricyanide, these reactions are continually repeated until the whole of the manganese is peroxidised. To effect this, it was found that about 10 lb. of the ferrocyanide were requisite per ton of manganese mud, and Mr. Valentin calculated that this form of process would yield 'bleach' at about 10s. per ton cheaper than Weldon's process. Unfortunately, a difficulty was encountered. It was necessary that the ferrocyanide should be recovered for two reasons, viz., on account of its cost, and to prevent cyanogen compounds entering the chamber with the chlorine; and to recover the ferricyanide it was found necessary to filter the mud, an operation which on so large a scale proved to be impracticable.

This process of Mr. Weldon's is fraught with interest apart from its industrial value. We have seen that its inventor claims to have proved the formation of manganites—that is, bodies which may be viewed as salts in which the base is calcium or manganese protoxide, and the acid radical manganic peroxide; thus, CaOMnO_2 and MnOMnO_2 ; and possibly also $(\text{CaO}, \text{MnO})(\text{MnO}_2)_2$.

The great interest of the process attaches to the high state of oxidation attained by the manganese. If air, or even oxygen, be blown through protoxide of manganese suspended in solution, only the sesquioxide is formed

(Mn_2O_3); but, as before said, if this oxidation be effected in the presence of ferricyanide of potassium, peroxide of manganese (MnO_2) is produced. Mr. Valentin explains this as a process in which the ferricyanide acts as a carrier of oxygen, and it is instructive to compare this reaction with other similar ones known to chemical science.

Suboxide of copper, or cuprous oxide Cu_2O , is a red body, and tolerably stable in the pure state at normal temperatures. When dry, it passes into a higher state of oxidation if heated to a temperature considerably above 100°C . If placed in water and submitted to a current of air or oxygen, it is unaffected, as the author has shown; but the presence of a small quantity of a caustic alkali under these conditions induces a peroxidation even in the cold, and more rapidly in the hot; and in this way the red lower oxide is transformed into the black oxide, CuO . Here, therefore, the alkali acts as a carrier of oxygen, and this hypothesis derives considerable support from Harcourt's discovery of higher oxides of potassium and sodium than those which form the base of ordinary caustic alkaline solutions. It is, therefore, to be supposed that in the above reaction the oxide of sodium or potassium is, for the time being, continually peroxidised and reduced, yielding the oxygen thus carried to the oxide of copper.

There are many such 'continuous actions,' as they are called, in chemistry. As we have seen in a previous chapter, sulphuric acid is manufactured by a process in which an oxide of nitrogen acts as a carrier of oxygen to sulphurous anhydride, and there is practically attempted, and partially realised, what theoretically takes place, viz., the transformation of an infinitely large amount of sul-

phurous anhydride into sulphuric acid, by means of an indefinitely small quantity of nitric acid.

The process by which ordinary ether is made, is another similar and striking instance of this class of reactions, and may be expressed as the conversion of an infinitely large amount of alcohol into ether, by means of an indefinitely small quantity of sulphuric acid. Thus the process is supposed to take place in two distinct phases, and that this truly represents what actually occurs, has become almost matter of certainty, through some elaborate researches of Williamson.

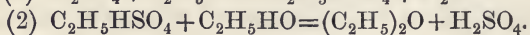
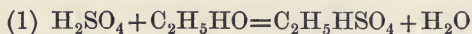

In the next chapter we shall consider an improved form of Mr. Weldon's process as here described.

CHAPTER XV.

WELDON'S MAGNESIA CHLORINE PROCESS (*b*).

THE success attending Weldon's process for the manufacture of chlorine gave an impetus to researches in chemical industry, and one result was the perfection of another method for making chlorine devised by Mr. Deacon of Widnes. This process we shall describe in the next chapter.

Here we shall record those efforts made by Mr. Weldon to perfect his own process by the substitution of magnesia (to be recovered) in the place of lime.

These experiments must be regarded as highly successful, and showed that the process admitted of many modifications, none of which, however, have been adopted by manufacturers for one reason, viz., because they were satisfied with the results obtainable with the old form of the process.

Should an increased demand for bleaching powder arise, it is not unlikely that the process now to be described will come into use.

The process commences by neutralising the acid liquor from the stills, formed by the action of hydrochloric acid on native manganese, with Greek stone or very nearly pure magnesite (carbonate of magnesium). Or, if it be desirable, the Greek stone may be first calcined and the light, easily-dissolved magnesia powder, so

made, used in its stead. This operation is performed in a well of cast-iron, or the liquor may be neutralised in the stills.

The mixed chlorides of manganese and magnesium liquor, obtained as described, is pumped into the settlers, where any peroxide of iron, alumina and gypsum deposit. This gypsum is derived from the sulphuric acid contained in commercial hydrochloric acid. From the settlers the liquor is run into an iron pot or pan, where it is evaporated until it attains a state of concentration, registering a temperature of about 320° Fahr. At this stage the evolution of hydrochloric acid gas commences, from the decomposition of the magnesian chloride by water. By opening a screw plug (of metal) it is now run into a muffle furnace, consisting of two divisions, which communicate with each other by means of an iron door worked by a pulley from without.

In one of these compartments the evaporation to dryness is completed, and is accompanied by the evolution of much hydrochloric acid, *plus* a little chlorine. The residue, which, by stirring constantly at this stage, is broken up into thin cakes, is then transferred by means of a rake into the second compartment, where it is heated with access of air.

Here the heat requires careful regulation, for if the temperature rises too high, fusion ensues, and thus the porosity of the mass is lost and oxidation impeded. The best heat is one designated 'blood-red,' and if this be attained and kept, the oxidation proceeds very regularly till the end. This tendency to fuse on the part of the mixture is due to the magnesian chloride, and therefore it is greater in the first place than afterwards, when it is

partially decomposed, as magnesia exhibits no such disposition. In other words, the furnace may be brightly red hot in the first compartment, because the temperature is greatly reduced by the evaporation which there takes place. As the mixture passes into the second compartment of the furnace, it consists of manganese chloride, together with magnesian chloride and magnesia, hence it is at this stage, that the temperature must be carefully watched; but as the decomposition proceeds, the magnesian chloride becomes less and less in quantity, and therefore the temperature may be allowed to increase to some extent with the decomposition. At the same time that the magnesium chloride undergoes decomposition, so also does the manganic chloride, and there is thus obtained protoxide of manganese, which absorbs oxygen from the air which is admitted, and becomes peroxide. This latter body appears to combine with the magnesia under these circumstances, and forms what Mr. Weldon has termed manganite of magnesium ($MgMnO_3$), which when properly made, is a dense, black, finely divided powder. It should be understood, however, that all the manganese is not peroxidised, in short, that there remains a certain portion as protoxide, and this, with the magnesia, constitutes what is termed the 'base,' that is, it furnishes with hydrochloric acid no free chlorine. It is only the manganese which exists as peroxide, that is capable of liberating chlorine in the stills. Now, so long as water is present in the furnace, hydrochloric acid is evolved, and as the main evaporation takes place in the first division of the furnace, it is chiefly hydrochloric acid which is there generated. In the second division it is chiefly chlorine

which is evolved, but it is of course mixed with some hydrochloric acid.

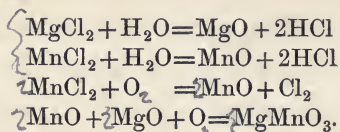

These equations probably represent the reactions in the order in which they occur in the furnace. It is, indeed, doubtful whether much manganese chloride is decomposed by the water, so long as there remains any chloride of magnesium, as this latter body is far more readily decomposable. Any water which may be left, would then attack the chloride of manganese, and finally, the mixture of oxide of manganese and magnesia absorbs oxygen to form the compound manganite of magnesium. Of course, to a certain extent, all these reactions take place at the same time, but not in the same measure.

Portions of the charge may be withdrawn from the furnace from time to time, and tested for the amount of manganic peroxide, and when this amount ceases to increase, the operation is concluded. The charge is now withdrawn, and is placed in the stills when cold, there to decompose a renewed quantity of hydrochloric acid, giving undiluted chlorine; the liquor so obtained is perfectly neutral, or may be made so by addition of a little magnesia, and is then ready to pass once more through the cycle of operations already sketched: so the process is repeated *ad infinitum*, without being attended with any waste product whatever.

The manganite of magnesium may be charged into the stills in one of two or three ways, namely, either in the state in which it comes from the furnace, or in the form of a sludge made by grinding it in a mill with

water, or it may be added gradually through a valve so constructed that while it admits the charge, it does not allow of the escape of the chlorine. In any case it is always charged in slight excess, so that there results a practically neutral still liquor. This liquor is allowed to settle somewhat before drawing off, so that any excess of the furnace-product left undecomposed is not lost, but remains in the still for a subsequent operation.

Now, we have seen that of all the chlorine formed in this process, that generated in the still alone is undiluted, whilst that evolved in the furnace is mixed with much hydrochloric acid and nitrogen from the air, together with that excess of air that may have been used in the process of fire oxidation (or *pyrooxidation*). The mixed gases are drawn by chimney draught, through the 'coke scrubbers' in the ordinary way (see Salt-cake chapter), by which means the hydrochloric acid is washed out, thus giving a product strong enough to serve the purpose of reacting upon fresh manganese in the still. Evidently, several courses now present themselves for dealing with the dilute chlorine. In the first case, the strong chlorine can be used at once in the old chambers, or it can be mixed with the dilute gas, producing a gas of sufficient strength to form 'bleach.' On the other hand, the weak chlorine admits of a process which effectually removes the air and the nitrogen. This was carried out on a manufacturing scale in St. Helens, by introducing the gases into leaden towers from below, where they, in their ascent, meet with a shower of milk of lime, which unites with the chlorine, forming at first ordinary 'bleach liquor,' but which, on the absorption of a further amount

of chlorine, produces a liquor containing only chloride of calcium and free hypochlorous acid, thus :—

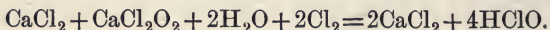

Assuming that such a liquor could be constantly obtained of this composition, it could be utilised in two or three ways. First, it admits of being pumped direct into the ‘octagons,’ where it is treated hot with chloride of potassium, to make chlorate of potassium ; or it may be placed in the still and treated with hydrochloric acid, when the following reaction occurs :—

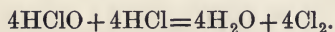

That is to say, the hypochlorous and hydrochloric acids mutually react, giving rise to free chlorine and water. The chloride of calcium takes no part in the reaction, and is lost. But here is the danger of the process. It is a difficult thing to keep down the temperature in the towers where the chlorine is absorbed by lime milk, and when the temperature rises above a certain height, chlorate of calcium is formed, and the presence of this body in the liquor might, if used in the stills, give rise to very serious accidents on account of the explosive nature of the oxides of chlorine there liberated in such a case. Moreover, the action of hydrochloric acid upon hypochlorous acid is terribly violent, and attended with danger. This danger is obviated, however, in great measure, by running the hypochlorous acid solution in a thin stream into the hydrochloric acid contained in the still. We have in chapter xiii. referred to the isolation of calcic hypochlorite, and shown that, in the future, manufacturers may possibly seek to make this body instead of bleaching-powder. This could only be done, so far as

we know, in one way, and that at present a difficult one. If it could be successfully accomplished, it would at once employ the liquors of which we have been treating above. Thus, in the towers, where the milk of lime is exposed to the chlorine, we should have to stop at that stage where bleach liquor results, and avoid the formation of hypochlorous acid. The reaction in that case would be as follows :—

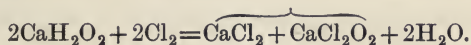

This liquor, as the author of this work has shown, gives, on evaporation in vacuo over sulphuric acid, a crystallisation of pure hypochlorite of calcium, leaving the very soluble chloride of calcium in solution. Now, if such an evaporation could be conducted on a manufacturing scale, so, surely, might this process assume the extent of a trade. Unfortunately, heat cannot be employed to concentrate the liquor, for in that case, as we have seen, calcic chlorate results.

Leaving this part of our subject, Mr. Weldon claims to be able to produce, by the manganite of magnesium chlorine process above sketched, 1 ton of bleach per 16 cwt. of salt used (to generate the hydrochloric acid). ‘This is about *four times* the average yield,’ says Mr. Weldon, in a manifesto of February 6, 1872, ‘obtained at present.’

Further, by varying the proportions of the chlorides of manganese and of magnesium, it can be so arranged that ‘the proportion of the strong chlorine generated in the still, to that of the weak chlorine produced in the furnace, may be anything between one to one and one to four, at will.’

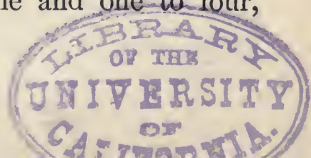

The process is continuous, and requires, from its simple character, but little skilled labour. No machinery (excepting liquor pumps) is involved; the plant required is comparatively low in cost, compared either with the Weldon process in general use, or Deacon's process, and Mr. Weldon claims for it the production of 'bleach' at a less cost per ton than by any other process, even throwing the whole cost on the strong chlorine only. These, however, are matters which, in event of the process being adopted, would require a more extended experience to decide with certainty.

One word more may conveniently be said here regarding the furnace product. Its composition, of course, varies with the nature of the liquors which furnish it, that is to say, it depends upon the relation existing between the chlorides of manganese and magnesium employed; and as the magnesia does not serve to generate chlorine, but only to neutralise the 'still' liquors, and to assist by its presence, in the oxidation of the manganese protoxide, it becomes desirable to use the minimum amount allowable.

Theoretically, the best proportions are those of one to one, because, in the compound manganite, this is the relation in which the magnesium stands to the manganese (MgMnO_3). Had the furnace-product this exact constitution, it would have the value, in terms of oxygen, of a native ore containing 68.3 per cent. MnO_2 ; but probably, owing to the excess of magnesia, and manganese existing as protoxide, the percentage of manganic dioxide in the product would practically be about 40 to 50 per cent. Finally, it should be stated that Mr. Weldon has proposed the plans of dealing with the dilute chlorine,

not only in regard to his own process, but as equally applicable to chlorine furnished in a dilute state by any other process, such as Deacon's, to be hereafter studied.

As a matter of history, it should be remarked that several plants were erected in Lancashire for working this improved form of Weldon's process, but they were ultimately abandoned. At the time, bleaching powder had undergone a depreciation in value, and, in fact, the production was in excess of the demand. Meanwhile Deacon's process was being condemned by many manufacturers as much less successful than Weldon's old process. In the face of these facts, producers did not feel justified in adopting the new form of a process which in its original modification gives such excellent results.

We have described, however, the improvements somewhat fully, from the conviction of their possible importance in the future. This conviction is strengthened by the writer's personal acquaintance with the process and its working results. Its great importance rests upon the fact that the loss of lime experienced in Weldon's process now in general use, is obviated by these improvements, while if magnesia be substituted in the towers for absorbing the dilute chlorine, there is virtually no loss of hydrochloric acid experienced, for side by side with hypochlorous acid, magnesian chloride is produced, and from this the hydrochloric acid is regenerated by simple evaporation and ignition.

At the same time, the element of cost enters largely into all these matters, and an extended experience could alone decide their feasibility in practice.

CHAPTER XVI.

DEACON'S AND OTHER CHLORINE PROCESSES.

THE process bearing Mr. Deacon's name was first brought before the public, at the British Association meeting of 1870. It excited at that time much attention, and indeed, for some period it was doubtful whether it would not rival or even displace the Weldon process. Further experience, however, discovered difficulties in the practical working of this beautiful method, which exercise a deteriorating influence on its value, and lessen its applicability. Although several plants have been erected in connection with this mode of manufacturing chlorine, most of them have been since abandoned, and at the present time, as we have seen, most of the chlorine is manufactured according to the process of Mr. Weldon.

Mr. Deacon laboured hard to perfect his method, even up to the time of his lamented death, and during his investigation many important facts were discovered. These he communicated in the form of a lecture to the Chemical Society of London, on June 20, 1872. The process itself consists in passing 'roaster' or hydrochloric acid gas along with air, over sulphate of copper superficially dried upon some refractory substance, such as brick. For the time being, the sulphate of copper appears to be transformed into chloride of copper; and, in fact, it would seem that the process may be viewed as

a combination of two reactions, which occur simultaneously :—

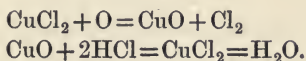

These equations may at least be considered to represent the extreme result attainable. It has long been known that chlorine is formed when hydrochloric acid and air are heated strongly together, and in a previous chapter we have observed that the reactions represented by the above two equations were also known to chemists.

Mr. Deacon's process combines these two, and he further employs sulphate of copper, which allows the formation of chlorine to take place at much lower temperature than otherwise. Theoretically, the action itself should generate enough heat for the purpose, but practically, owing to losses by radiation, etc., a considerable amount of fuel is required to aid the process.

Originally, common red brick was employed for the purpose of exposing a surface of the sulphate of copper to the mixed gases, and at the present time, at one place, to our knowledge, firebrick broken up into pieces of the size of a walnut is employed. But Mr. Deacon preferred, we believe, to employ clay balls or marbles, and recently, we are informed, he had used a mixed solution of the sulphates of copper and of sodium. The sulphate of sodium appeared not only to increase the activity, but, moreover, increased the resistance offered to permanent decomposition of the cupric sulphate. Mr. Deacon has shown that the action is essentially a surface one, and ' it would appear that there is a certain comparatively small range of temperature, between the critical limits of which, the percentage of hydrochloric acid decomposed, varies

greatly, and that this is not the same for the chloride as for the sulphate (of copper), being higher for sulphate.'

He has further concluded that, 'other conditions remaining the same, the percentage of hydrochloric acid decomposed varies with the square root of the proportionate volume of oxygen to hydrochloric acid,' and 'that the chloride of copper formed bears no definite proportion to the amount of chlorine produced.' In the absence of clay, and below a certain temperature, chlorine is freely formed, without conversion of the sulphate; but in the presence of clay the sulphate becomes transformed into chloride, and in any case, above a certain temperature (about 800° Fahr.), chloride is permanently formed, and volatilises. The bricks or marbles are dipped in sulphate of copper, dried, and placed in the *decomposer*, which is constructed of iron and encased in brickwork. Under these circumstances they are maintained at a temperature of 700° to 750° Fahr. (below 400° Fahr. the reaction does not occur).

Taking the hydrochloric acid gas as it is furnished in the salt-cake apparatus, described in a preceding chapter, it is found to contain enough air to insure the decomposition of the hydrochloric acid gas, although it is in the power of the manufacturer to vary the proportions within limits, at will. The mixed gases are drawn over the marbles by mechanical suction, or chimney draught.

Latterly, Mr. Deacon had improved his decomposer, because it was found that, after a few months' working, the brick would become inactive. In this improved form of apparatus, he seeks to remedy this defect, by making arrangements through which the inactive, worked-out firebrick can be withdrawn through a trap, and a fresh

supply added once a week from the top, from which it descends by its own gravity to the copper-soaked marbles. All this can be done without stopping work, and better results are expected from it than are secured with the ordinary form of decomposer.

Previous to this improvement, difficulties had been encountered in this direction. It had been observed that after a certain period of regular working, the catalytic agent lost its power in some degree, and this appeared to be at least partly due to the volatilisation of some chloride of copper, and to its consequent localisation in specific places, or the sulphate of copper gradually worked itself into the interior of the brick, leaving the surfaces deprived of part of its activity. To remedy these evils, Mr. Deacon would allow the decomposer to cool down from time to time to about 220° Fahr. and then pass in steam. This dissolved the copper sulphate, and the solution thus formed was in this way once more gradually distributed over the surface of the brick or other matter. It is difficult to speak in a precise manner about these obstacles and their remedies, for the real chemical reactions occurring are still, in great measure, matters of speculation. Mr. Deacon appeared to believe that the process, when properly conducted, did not depend upon the transformation of the sulphate into chloride of copper, but viewed the production of the chlorine as resulting from a mere decomposition of hydrochloric acid by oxygen, brought about by contact or collision of the gaseous molecules with the sulphate of copper. Thus he regarded it in some way to be a mechanical action only; but this is scarcely warrantable, when it is considered that contact with some sorts of substances is not so effectual as is the

case with other sorts. The fact that there is a difference of power at all in what is called the catalytic substance, implies a difference of process.

Thus chromic oxide has the same kind of power as the sulphate of copper in transforming hydrochloric acid and oxygen into chlorine and water, and, indeed, its use was patented by a Belgian as an improvement on the latter substance. But while it has the advantage of non-volatility, its use is open to the same objection that is true of any form of the process, viz., the production of dilute chlorine.

Before passing on to this subject, however, we may add that among other substances which act like sulphate of copper and chromic oxide, are platinum black or spongy platinum, manganese compounds, etc. Platinum is best used by soaking brick, or asbestos in a solution of its chloride; if then the substance be subjected to a red heat, the platinic compound is decomposed, leaving a film of the metal over the surface. Any porous substance has the catalytic power, only in a less degree than when supplemented by some such agent as sulphate of copper.

To return to the study of the chlorine produced by this process. It is associated with all the nitrogen of the air, and any excess of air that may have been used, and for a long time it was thought that such dilute chlorine could not be used for making strong bleaching powder, that is, it would present difficulty in its absorption by lime. Nevertheless, by careful regulation of the amount of air used, a gas can be obtained which will produce 'bleach' of full strength, under conditions to be hereafter described.

A perfect decomposition of the hydrochloric acid is never effected, and hence it becomes necessary to wash out the hydrochloric acid attached to the chlorine *en route* for the chambers. Hence, in any case, Weldon's or some other process would have to be employed to work up this condensed hydrochloric acid. Of course it could be used by boiling it to generate fresh gas for the 'decomposer'; but this would entail a large consumption of fuel. After freeing the chlorine from hydrochloric acid, it has to be dried by passing through a tower, wherein it is exposed to sulphuric acid of specific gravity 1.6, and in some works it then passes on to another tower packed with fused chloride of calcium. Here the drying is completed, and the gas is then ready for chamber consumption. But for this purpose the ordinary form of chamber, the consideration of which matter we reserve for our next chapter, cannot be employed. In this place we shall briefly describe the form of chamber used in the Deacon process only.

The stronger and purer the chlorine, the more readily is it absorbed by lime, and *vice versâ*. When dealing, therefore, with such dilute gas as is obtained in the process under description, there must be presented to it a larger surface of absorbing material, and this is done by spreading upon a series of shelves made of slate, lime to the depth only of about $\frac{5}{8}$ of an inch. The lime is charged into the chambers from the top through a hopper, and is then spread upon the shelves by means of a rake having a gauge of $\frac{5}{8}$ of an inch. These shelves are 6 inches one below the other, and are so constructed that the fresh chlorine first passes over that powder, which is already most nearly saturated, and thence to the less chlorinated

lime. In this way good bleach containing 37 or 38 per cent. chlorine may be readily prepared.

Altogether, the Deacon process, so far, cannot be said to have worked so well as was expected, and no plant yet constructed, has been able to produce that amount of bleaching powder which it was calculated and destined to give.

The various difficulties encountered in the process of working may be thus enumerated:—

1. The roaster gas is liable to contain carbonic acid gas, which presents an obstacle in the production of good bleach, forming as it does carbonate.

2. The plant being largely constructed of iron and exposed to high and inevitably varying temperatures, the joints are liable to give way, and admit the products of combustion from the furnace outside.

3. The copper is apt to volatilise as chloride, which condenses in the cooler part of the decomposer, impeding the draught, and involving stoppage for cleaning; while the marble, under such circumstances, requires periodically redressing.

We have endeavoured to sketch this process fairly and truthfully, and if we appear to have laid special stress upon the difficulties inherent in it, we feel justified by the importance of the subject. Nevertheless, the circumstances and conditions under which this process can attain commercial success, may yet be discovered, and thus reward the indefatigable exertions already made to perfect it, by Mr. Deacon and his chemist, Dr. Hurter.

Illustrative of these difficulties, it may be stated that a new anemometer, for measuring the speeds of the gases to the decomposer, had to be invented, and also new

forms of pyrometers for indicating their temperatures. Further, when it is considered that a manufacturer, making 40 tons of sulphate of sodium daily, in order to use all his hydrochloric acid as generated, would have to deal with about 1,100,000 cubic feet of gases, the means whereby they have been enabled to partly accomplish this, reflect exceedingly well on those who have devised them.

In passing from this study, there yet remains one other process to be described before we proceed to some further considerations regarding the production of bleaching powder. The process we refer to, is the subject of a patent by Messrs. James Hargreaves and Thomas Robinson, and has been proposed in reference to the manufacture of hydrochloric acid and chlorine.

One part of potassic or sodic chloride is mixed with two to three parts of oxide of chromium, and with or without magnesium or manganese as oxide, or in the form of a salt, to assist in the production of chromic acid. The mixture is moulded into bricks with water, and then dried. These are then exposed to a current of air, at a temperature which may be expressed as 'red heat,' but below fusion, in a series of furnaces or other chambers. In this way chlorine is generated, and the sodium or potassium converted into chromate. If hydrochloric acid be the desired product, along with the current of air, is used one of steam also. In both instances, if desirable, the air may first be made red hot by use of the air-heating apparatus of the Messrs. Siemens. The equations illustrating the decompositions may be thus expressed :—

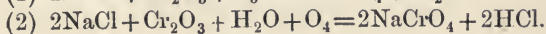
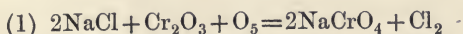

CHAPTER XVII.

MANUFACTURE OF BLEACHING POWDER, BLEACHING LIQUOR,
CHLORATE OF POTASSIUM, AND EPSOM SALTS.

BLEACHING POWDER is produced commercially by the action of chlorine prepared by any of the afore-described processes upon slaked lime.

The chlorine gas is first dried by passage through small leaden or other purifiers, packed with coke or flints, kept well supplied with strong sulphuric acid. In many works the chlorine is washed by passing it through water before drying. This is done in order to prevent the occurrence of traces of manganese in the bleaching powder—for it is asserted that peroxide of manganese, even when present in very minute amounts, greatly facilitates the spontaneous decomposition of the product, with the evolution of oxygen. This is a matter, however, yet requiring investigation. The choice of the lime used is of much importance, many kinds containing traces of ferric or manganic oxide; and such substances give to the 'bleach' the induced liability to decomposition already referred to. Such lime is to be identified by its yellow colour. Irish and French limestones furnish, by a process of calcination, most of the lime used in this country, as they give a 'heavy' lime, which is the best sort to employ. Large quantities of limestone are also obtained from Buxton.

Having obtained the lime in a well-burnt state, it has next to be carefully slaked; if too much water be employed in the operation, the product agglomerates; and if too little water be used, the product absorbs chlorine imperfectly. After slaking, it is sifted from the 'yelks'—that is, unburned carbonate, pebbles and impurities—and should then contain about 24 per cent. water, in addition to that amount necessary to form hydrate of lime. The vessels, in which the absorption of chlorine by the lime takes place are called 'chambers,' and, as originally constructed, were virtually leaden receivers, in which the lime was stirred from time to time.

When bleaching powder was first made on the Tyne—viz., in 1830, by Losh, Wilson, and Bell—wooden chambers covered with pitch were used. Then came chambers of brick, which gave way eventually to others constructed of stone (Yorkshire flagstone), or lead, or both; some, however, are constructed of iron. Usually, these chambers are built upon the ground, but sometimes they are supported upon a wooden framework. It was usual, moreover, in the past, to place the lime upon a series of shelves to a depth of 5 to 8 centim. (2 to 3 inches); these shelves were situated about 6 inches one above the other, and three or four in number were used. Except where chlorine generated by Deacon's process is used, shelves are no longer employed; and instead thereof, the lime is placed upon the floor to a depth of about six inches.

Chambers, as now usually constructed, are from 50 to 60 feet long, 25 to 30 feet wide, and from 5 to 6 feet high. Most of them are built of lead, in which case they

are tarred inside. In any case the bleaching powder is kept from contact with the metal, by having the sides (to the depth of the lime) built of flagstones, on which the leaden or iron body rests. The chambers are provided with doors which are luted on, after the charge of lime has been introduced, and there are also small windows through which may be seen the colour of the gas, a criterion, to an experienced workman, of the progress of the absorption.

The charge of lime varies according to the size of the chamber, 72 cwt. sometimes being employed, and sometimes 144 cwt. This having been introduced and the chambers closed, the gas is allowed to enter slowly; if the operation proceeds too quickly, the temperature rises owing to the combination, and the hypochlorite of calcium which is formed, decomposes into chlorate and chloride. The temperature generally observed is 62° Fahr., although Scheurer-Kestner is of opinion that a temperature of 130° Fahr. is not injurious so long as the chlorine does not enter too rapidly. 12 cwt. of good lime yield about 20 cwt. of bleaching powder, testing 37 per cent. chlorine; or, expressed generally, 100 parts of lime should absorb from 64 to 66 parts of chlorine, giving a product testing from 35 to 37 per cent. chlorine.

Under ordinary conditions, 36 to 48 hours are required to saturate the lime with chlorine; when completed, the residual chlorine is drawn off by chimney draft or otherwise, into a freshly charged chamber, leaving the contents ready for packing. The doors are now unluted, and the 'bleach' is drawn by wooden rakes towards them, by workmen who protect themselves from the chlorine by holding in their mouths wet rags or

flannel. The powder is packed firmly in dry wooden casks, and in this state is supplied to the market.

The following analyses of bleaching powder are by Mr. G. E. Davis, and may be taken as fairly representative:—

ANALYSES OF GOOD SAMPLES.

Form of Chlorine.	1	2	3	4	5
Total chlorine .	36.40	35.54	38.62	37.76	39.52
Active chlorine .	35.12	35.00	35.50	35.87	36.11

ANALYSES OF BAD SAMPLES.

Form of Chlorine.	1	2	3	4	5
Total chlorine .	33.86	37.24	30.52	30.90	37.51
Active chlorine.	30.25	31.33	29.46	27.87	32.30

The actual value of the powder depends upon its percentage of active chlorine, and the difference between the percentages of total and active chlorine, is that amount in combination as chloride of calcium, which is of course useless for bleaching purposes. The commercial bleaching powder has therefore a composition which may be represented by

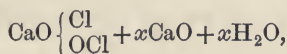

and contains on the average, 35 to 39 per cent. chlorine, 43 to 44 per cent. lime, and 15 to 16 per cent. water, with traces of foreign matters.

Bleaching powder slowly undergoes spontaneous decomposition, and Mr. J. Pattinson finds that during a summer month the loss of available chlorine may rise as high as 0.86 per cent. on the average; in a winter month, it loses about 0.26 per cent. on the average.

In a factory where 350 tons of salt were decomposed weekly, and the strong hydrochloric acid employed in making 'bleach,' the following were the working results, reduced to a standard of 20 cwt. of salt :—Common salt, 2,240 parts; hydrochloric acid at 28° Tw., 2,753 parts; manganese at 60 per cent. = 448 parts; producing 416 parts of bleach at 39 per cent. (Richardson and Watts). These figures relate to the industry prior to the revolution brought about by the introduction of the Weldon process; so also do the following figures, taken from the same source :—Eight large stills in Lancashire supplied five chambers, each still being charged with 7 or 8 cwt. of manganese, and 90 cubic feet of acid at 28° Tw. Each chamber was charged with 43 cwt. lime, taking a week for complete saturation, and giving a production of 64 cwt. of 'bleach' at 35 per cent. strength.

Using Weldon's process for the generation of the chlorine, a ton of 'bleach' is produced from about 50 to 55 cwt. of salt, decomposed. In the Lancashire district, during 1866, it is calculated that 20,000 tons of bleaching powder were produced by twenty manufacturers, while in 1867 the Tyne district yielded 27,000 tons. In 1871, the estimated production of Great Britain and Ireland was 75,000 tons, selling at 10*l.* per ton, giving, therefore, a total value of three-quarters of a million sterling. At the present time the annual production is about 100,000 tons, and over 90 per cent. of this is made, using Weldon's form of chlorine process; but this latter calculation does not include about 10,000 tons made by Dunlop's process in Glasgow. In 1799, bleaching powder had a value of 168*l.* per ton; its present value is 5*l.* per ton.

Of late years, certain attempts have been made to intro-

duce an improved form of apparatus or chamber in which the lime absorbs chlorine. We have seen that where Deacon's process is used, it is so contrived that the partly-saturated lime is exposed first to the action of the stronger gas, etc. This idea, we believe, originated with Mr. Gamble, but it is the same idea that pervades the use of the various pieces of apparatus recently devised. That is to say, in all of them it is attempted to bring the gas into more intimate contact with the lime, thus effecting the absorption in a less time than otherwise. This is a result especially desirable to obtain, when a dilute gas is employed, such a gas, in fact, as that furnished in Deacon's process.

Thus, in some places, revolving cylinders have been employed, and were first adopted by Oberkampf and Widmer in Germany (1816). At home, these cylinders were of sheet iron, 5 feet in diameter, 14 feet long, and coated with cement internally. Each cylinder was charged with 14 cwt. of lime, and made about twelve to fifteen revolutions per hour. The casks in which the powder was packed, were placed beneath the cylinders, and received their charges after passing through a tammy (sieve). It is conceivable that, using the form of chamber now generally adopted, a simple piece of machinery might be devised, which should act as a haymaking machine, by constantly exposing fresh surfaces of lime to the action of the chlorine. In such case, lime might be used to the depth of several feet.

Mr. Bramwell, of St. Helens, has patented the use of an apparatus, which consists essentially of an iron cylinder, provided with pipes for working the gases, and a door for discharging the finished powder. The cylinder

is provided with a rod passing through its centre (horizontally), and from this rod project a number of arms in various directions. When the cylinder is charged with lime, gas is admitted, and the apparatus within, is caused to work up and down, thus making minute spaces in the lime, into which the gas is supposed to enter, and thus effect the object of the invention. So far as we can learn, however, it has not been tried at all, although if it worked it would have the decided advantage of economising space—no mean consideration.

In another tower-form of chamber, patented by Mr. Leather, of St. Helens, the lime falls in the form of powder from a hopper, and is kept in agitation as it falls, the chlorine meeting it from below. We are informed that the experiments made a short time since with this tower-method of making bleach, gave results not at all satisfactory.

In a third apparatus of Mr. Hargreaves, the lime is placed at the top of a spiral shelf, and is moved gradually downwards by means of a scraper, which, in its action, thus continually exposes fresh surfaces of lime to the chlorine, which enters below and meets the lime in its descent. By the time the lime reaches the bottom, it is supposed to be literally converted into 'bleach,' but, so far as we can learn, no experiments have yet been made with this apparatus.

In further reference to the manufacture of bleaching powder, the following notes by R. C. Clapham, relative to the trade, as practised in France, are not without interest. The Weldon process is now pretty largely used, but at the time of which we are writing (1874), it had not come into operation.

Instead of using stills, such as we have described in preceding chapters, the French used retorts, made of fire-clay, and not unlike Wolff's bottles in form. A charge consisted of 50 lb. of ground manganese, with sufficient hydrochloric acid of 30° to 32° , and was worked off either by the heat derived from a flue, or by steam. In this way a very complete decomposition of the manganese was effected, the chlorine being conveyed in glass pipes to the chambers. The latter were constructed of stone flags, containing a number of shelves, upon which the lime was spread, and the absorption was not allowed to extend above 32° , which is the usual French standard. Many persons claim for a 'bleach' of this strength more stability than for stronger ones.

Bleach liquor is still a manufactured product in Great Britain, and, indeed, in 1866, no less than 5,871 tons were produced in the Lancashire district alone. It is made by submitting milk of lime to the action of chlorine, either in towers, as described under 'Weldon's Magnesia Process,' or in a cylinder, enclosed in a wooden box. Mr. Deacon proposed to substitute the carbonate of lime for the hydrate ordinarily employed. In such case a tower is used, packed with chalk or limestone, over which water slowly trickles, as the chlorine ascends from below; or the carbonate may be ground and made into a milk with water, and the product submitted to the action of the gas in the same kind of apparatus.

Chlorate of Potassium is also largely made from chlorine, in the manner we shall now proceed to describe. In the form of process generally employed, milk of lime is submitted to the action of chlorine in the hot, and is

thereby resolved into calcic-chlorate and chloride, thus :—

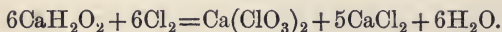

To the concentrated solution of the mixed salts, potassium chloride is then added, in the proportion of 74·5 parts to each 168 of caustic lime originally used, when the following reaction takes place :—

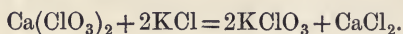

In practice, however, the milk of lime is submitted to the action of the chlorine in presence of the potassic chloride, until the liquor shows a pink colour, or till free chlorine escapes unabsorbed. The liquors are then allowed to settle in the same vessel, run off, and allowed to crystallise in iron pots or pans. The rough crystals of potassic chlorate, which take about six or seven days to form properly, are powdered and redissolved by hot water in this way. The crystals are placed in bags, and the water is allowed to permeate the contents at such a rate that as the solution drops through the bag into the crystallising settlers beneath, it is in a concentrated form. The crystals formed in the settlers are separated from the dust by the motion of an eccentric apparatus, while the mother-liquor is used for redissolving fresh crops of crystals. Ultimately, the calcic chloride solution is thrown away.

Owing to the dangerous nature of chlorate of potassium, a carbonic acid apparatus is generally kept near at hand, to extinguish any fire that may possibly occur. The ‘agitators’ or ‘octagons’ in which the chlorate is made, are, as their name implies, eight-sided vessels at times, though generally they are cylindrical in form

The substance is used not only in match-making, but also as an oxidising agent for steam colours on calico, etc. We believe that from 12 to 20 tons are made weekly in St. Helens alone, while in 1871 the total make amounted to 750 tons, having a value of 105*l.* per ton, or an aggregate value of nearly 80,000*l.* The only improvement we have to indicate in reference to this manufacture, is one which was proposed by Mr. Walter Weldon after having performed a great number of experiments, showing the feasibility of the proposition, although it has not yet been adopted, so far as we can learn. It consists in the use of magnesia instead of lime, thus obtaining a residue of magnesian chloride instead of calcic chloride, and from which the magnesia is constantly regenerated with the production of hydrochloric acid, by simple evaporation to dryness in a current of steam and continued roasting.

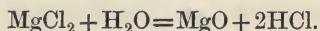

The hydrochloric acid can be condensed in the ordinary way for further use.

Magnesia may be readily obtained, as stated elsewhere, by simple roasting of the native carbonate which occurs in a nearly pure form as Greek stone or magnesite. *En passant*, it may be remarked that Epsom salts (Mg SO_4) are made from this magnesite by the action of sulphuric acid. No less than 590 tons are made annually in the Tyne district (1867), and have an aggregate value of 4,720*l.* Epsom salts are also made by Mr. Gamble, at St. Helens.

CHAPTER XVIII.

GENERAL CONSIDERATIONS REGARDING THE ALKALI TRADE ;
CHEMICAL CLIMATOLOGY, ETC.

IN the foregoing chapters we have studied the growth of the alkali trade from its beginnings, and at all stages it is evident that the improvements which have been from time to time effected in this large industry, have been chiefly directed to the utilisation of once waste products. In fact, its history, like that of the English nation, is one of slow progression, in which advancement has been made chiefly by a process of evolution rather than by one of revolution.

The question before the manufacturer takes the form of highest possible profits from the smallest possible outlay; and in England, where labour is high-priced and competition so powerful, the quantity of 'turn out' has been the main object in view. Here and there, owing to this system, and to the gigantic scale on which the various manufactures we have described, are practised, excellence of production has at times been to some extent forgotten. On the whole, however, owing to the intimate acquaintance of our manufacturers with the practical working of the various processes, this country is far in advance of all others in chemical industry. At the same time it must be confessed, to our shame, perhaps, that while this is so, the attention of manufacturers is

more readily commanded by the voice which proclaims a reduction in the cost of producing rather than by one setting forth the merits of an entirely new process. In other words, they are far more 'practical' than scientific. The element of competition, however, atones in some measure for this evil, and if one producer, by the utilisation of a waste product, or by the adoption of an innovation, can enter the market and sell with greater advantage than his compeers, they are generally not slow to follow.

It is therefore the object of manufacturers, for the sake of their own purse—with them the strongest argument—to make the most out of a certain outlay, and this can best be done by working with care, and keeping down waste as low as possible. Such waste proves a nuisance as well as an expense.

We have seen that in years gone by, most of the hydrochloric acid resulting from the decomposition of salt was allowed to escape into the atmosphere. This caused residential habitation in certain districts to be quite impossible, while the noxious vapour rendered the surrounding country desolate, as if stricken with some dire disease. The grass perished, the trees died, crops were ruined, and the birds and insects departed or became extinct, until owners of property brought numerous actions for damages against the proprietors of the works from which the evil gases were generated. The evil became so serious in 1863, that the Legislature interfered, on the suggestion of the late Earl of Derby, and passed an Act which compelled manufacturers of alkali to condense no less than 95 per cent. of the total muriatic acid evolved in the salt-cake furnaces. The means of effecting

such absorption were ready to hand, and had, indeed, been devised by Mr. Gossage long before their use was rendered imperative. Almost simultaneously there came an increased demand for bleaching powder, owing to the causes we have previously sketched, and it is from that once wasted hydrochloric acid that the demand for 'bleach' is now fed, by the manufacture of chlorine therefrom.

As time went on, there arose the copper extraction industry (by the wet method), but it brought with it another evil, for in the process of roasting the burnt pyrites with salt, much hydrochloric acid and some sulphurous anhydride is evolved. In the meantime, the Act of 1863 only applied to soda works, and the extractors of copper for a time went free. In 1874, however, the Act was amended, and copper and sulphuric acid works were placed under similar restrictions to those above set forth. The result is that, as regards hydrochloric acid, not only is 95 per cent. of the total quantity evolved, condensed, but in many works even 99 per cent. is saved, while cases rarely occur in which the quantity of hydrochloric acid contained in the chimney-gas exceeds one-fifth of a grain per cubic foot. Considerable evil is nevertheless exerted by the escape of muriatic gas in the immediate vicinity of alkali works. This escape results from the method of raking the finished salt-cake out upon the open ground, when all the residual acid gas enclosed between the solid parts of the charge is liberated, and exerts a most deleterious influence upon the workmen, who generally stand at their work with wet rags in their mouth. Should the salt cake be imperfectly roasted, the evil is of course much greater.

These matters are, however, carefully watched by the inspectors appointed under the above Act of Parliament, while those furnaces and methods which have been more recently devised for manufacturing salt-cake, avoid, in great measure, even this residual evil, either by causing the charge when finished to cool in closed receptacles, or by effecting a more complete decomposition of the salt.

Another nuisance is created by the escape of sulphurous anhydride and nitrous vapours into the atmosphere, an evil which was of course incomparably greater in past days, when the chamber gases were passed direct into the chimney shaft, than now, when Gay-Lussac's and Glover's towers are so widely used. In badly managed works, the quantity of sulphur—in every form—contained in the residual chamber gas often amounts to 16 grains per cubic foot (Roscoe), while it should certainly not exceed, when proper care is taken, 1 grain per cubic foot. The gas issuing from the chimney shaft should not contain more than $\frac{1}{4}$ grain of sulphur per cubic foot, half of which, however, is derived from the furnaces wherein coal or coke is burnt.

In well-conducted works there is but little escape of chlorine; when it is the case, from carelessness or otherwise, it proves one of the most painful of noxious influences. The workmen are necessarily exposed to it in some measure, when withdrawing the finished bleach from the chambers; but in addition to this, and an occasional leakage from the stills, or pipes which convey the gas, little evil results owing to the escape of chlorine.

During the process of 'salting down' the caustic pots, a considerable nuisance is often caused by the escape of

hot particles of salt into the atmosphere. When the salt is thrown into the red-hot caustic, it decrepitates and throws up a fine cloud of hot spray, which is very painful to persons in the neighbourhood. The nuisance may be, and is, avoided in great part by keeping the pots duly covered during the proceeding.

Passing from waste gases to liquids, we find far less cause for complaint than in years gone by, when nearly all the waste liquors of acid, chloride of manganese were discharged into the water streams. Such a waste, beyond the loss of manganese, exerted most deleterious influences, by ruining the potability of the water thus contaminated, and by destroying the fish living in the streams. Not only so, but the acid thus so readily spread over the surrounding neighbourhood constantly came in contact with vat waste, and thereby liberated volumes of sulphuretted hydrogen and sulphurous anhydride into the atmosphere, to the distress and injury of resident people. Now, however, since the introduction of Weldon's process, this evil is greatly obviated, yet not entirely, for although chloride of calcium is of far less value to the manufacturer, who can therefore afford the better to throw it away in preference to mixed hydrochloric acid and chloride of manganese, its presence by no means improves the quality of water. This waste product, therefore, is an evil which must be swept away sooner or later; and in previous chapters we have indicated the means proposed by Mr. Weldon to effect this step, viz., the substitution of magnesia for lime in his process, and the utilisation, by regeneration, of it and the chlorine with which it is in combination as chloride.

The greatest evil in the alkali trade, soda waste, we have already adverted to—greatest, because of the valuable ingredients it contains though a waste product, and on account of a constant evolution of sulphuretted hydrogen from it, by the action of water and carbonic acid upon the sulphides it contains. While, as we have seen, some sulphur is regenerated from it by Mond's process, and yet more by Mactear's, most of the enormous quantity of alkali waste produced in this country finds no better use than to fill up pits from which clay has been taken. Meanwhile, there are ranges of hills of it in various places, whose presence proclaim the imperfection of chemical knowledge and practical skill, although both are so boasted in the present day.

There is, moreover, another nuisance in connection with the alkali as well as other trades, which is, perhaps, of as much or greater import than 'vat waste' or 'blue-billy,' as it is called, namely, coal-smoke. Manufacturers may build their chimney-shafts ever so high, aye, even to top Egypt's proudest pyramid, but the smoke still rolls out its black stream ruthlessly, and, although it is diffused, it is not destroyed. Besides the mischief it creates, both on the bodily health and the mental peace of mankind, it speaks of wasted fuel and dissipated energy. Even in this direction, however, there is some hope of improvement, and of late, many attempts have been made to construct furnaces and stoking machines, which may prove serviceable in saving fuel, while at the same time the escaping smoke is lessened. These stoking machines aim at feeding into the furnace a continuous supply of fuel at the rate required, while providing a proper proportion of air to combine with the carbon and combus-

tible gases; to effect the perfect mixing of the air and gases; and, lastly, to prevent the resulting mixture from reduction in temperature below that of ignition, before the combustion is complete. These are difficult problems to solve, and the foremost chemical engineers of the day have but begun the attempt at solution. It is satisfactory, however, to know there is a beginning, and we may therefore hope for better things eventually.

In closing this chapter, we cannot refrain from a mention of the able services rendered in connection with the science of chemical climatology as related to the alkali trade, by Dr. Angus Smith, Mr. Fletcher, and Mr. James Mactear. For great difficulties are experienced in determining the rate at which gases issue from chimneys, seeing that the whole volume contained in a shaft does not move at one uniform rate. Beyond the successful removal of these obstacles, these gentlemen have also constructed most accurate anemometers, and have, indeed, laid the foundation of a science in this direction.

Manufacturers would do well to appreciate more fully than they do at present, that science is slow to progress, and on that progress all improvement in industrial applications depends. Let them, therefore, encourage its development by employing competent chemists; and not only so, but rather aid research than war against it, as they have too often done in the past. They cannot hinder the current of knowledge in its advance, but they can help to increase its rate of movement. In another direction they can also benefit humanity, by creating the means whereby their workmen may elevate themselves and train their children, in a better way than is to be witnessed now. Men have other relations one to the

other than those included in the commercial world of capital and labour, and this better side of life cannot be hidden even by the shadow of the Stock Exchange and the marts. Indeed, life may be compared to a spectrum with its bright and dark lines.

CHAPTER XIX.

STATISTICS OF THE ALKALI TRADE.

THE alkali trade, as it has been described in the foregoing chapters, may be said to be exclusively the growth of this century. The articles manufactured constitute, in many instances, the raw materials for other trades and industries, so that the alkali trade is in some measure dependent on the general state of trade in this and other countries. Consequently, great fluctuations in price and profit are experienced from time to time, a state of things often intensified by too rapid extension of plant beyond even the demand for the various manufactured products. We have already given many statistics relating to the articles consumed and manufactured in the alkali trade, under the headings of individual substances; here, therefore, we shall only give some figures regarding this industry, as it was fifteen years ago, and, more particularly, as it exists now. It should be remarked that it is a most difficult matter to make an accurate computation of the whole state of the trade, and, indeed, the only approximate one that has been constructed refers to the year 1866. Originally, as we have seen, in the days of the beginning of the trade, comparatively small amounts of products were manufactured, and these were sold at prices which, viewed against those now obtaining, seem ridiculously high. Thus, in 1805, bleaching powder was

worth 120*l.* per ton; in 1868, its price was 10*l.* 12*s.* per ton, while to-day it has a value of 4*l.* or 5*l.* per ton. Again, in 1801, alkali sold at about 49*l.* 5*s.* per ton, and in 1806, soda crystals sold at about 60*l.* per ton; to-day it is 4*l.* 15*s.* per ton. In 1736 sulphuric acid cost 2*s.* per lb., or 128*l.* per ton, while in 1866 it cost 6*l.* per ton; to-day it has a value of 5*l.* per ton. Bicarbonate of soda now sells at 17*l.* per ton; caustic soda of 60 per cent. at 13*l.* per ton, and chlorate of potassium at 9*d.* per lb.

Between the years 1852 and 1862, the total alkali trade more than doubled, while in the latter year the annual value of finished products amounted to 2,500,000*l.* At that date, the raw materials consumed per annum were as follow:—Salt, 254,000 tons; coal, 961,000; limestone and chalk, 280,500; pyrites, 264,000; nitrate of soda, 8,300; manganese, 33,000; timber (for casks), 33,000—total, 1,833,800 tons. There was a total capital employed of 2,010,000*l.*

It has been calculated that in 1861 there were about fifty soda works in Great Britain, with about the following quantities of ‘turn out’:—

Articles Manufactured	Per week	Annually
	Tons	Tons
Soda ash	3,000	156,000
Soda crystals	2,000	104,000
Soda bicarbonate	250	13,000
Bleaching powder	400	20,800

Employing about 10,000 persons, exclusive of mining operations and transportations, etc. Multiplying the above quantities in the first column by 52, to get the annual products, we obtain those in the second column.

Now, according to Messrs. Schunck, Smith, and

Roscoe, the Lancashire district alone, produced in 1861 the following quantities :—

Name of Article	Per week	Annually
	Tons	Tons
Common salt decomposed	2,600	135,000
Sulphuric acid (1.6) used	3,110	161,720
Hydrochloric acid (1.5) produced	3,800	176,800
Soda ash sold	1,800	93,600
Salt-cake	180	9,360
Soda crystals ($\text{Na}_2\text{CO}_3 \cdot 10\text{H}_2\text{O}$),,	170	8,840
Bicarbonate	225	11,700
Caustic soda	90	4,680

These quantities were calculated from the returns made by twenty-five works, so that, in comparison with the above figures relating to the whole of Great Britain, a very good idea is obtained of the distribution, so to speak, of the trade at that time.

Advancing to 1866, and acting on very good returns from twenty manufacturers in the Lancashire district, with the estimated production of six, it is found that 194,000 tons of salt were decomposed, with the production of the following quantities :—

Quantity returned		Price per ton	Total amount
	Tons	£ s. d.	£ s. d.
Soda crystals	24,978	6 0 0	149,868 0 0
Soda ash and refined alkali	87,314	11 0 0	960,454 0 0
Caustic soda	11,213	20 0 0	224,260 0 0
Bicarbonate of soda	6,457	18 0 0	116,226 0 0
Sulphate of soda	32,137	4 5 0	136,582 5 0
Bleaching powder.	20,006	14 0 0	280,084 0 0
Bleach liquor	5,871	3 0 0	17,613 0 0
Tons	187,976	Total .	£1,885,087 5 0
Oil of vitriol for sale	18,592	6 0 0	111,552 0 0
Muriatic acid ,,	13,819	0 15 0	10,364 5 0
Total tons	220,387	Total value	£2,007,003 10 0

In the Tyne district during the same year about 157,000 tons of salt were decomposed, and the following amounts of various products turned out:—

Quantity returned		Price per ton			Total amount		
	Tons.	£	s.	d.	£	s.	d.
Soda crystals	86,000	5	10	0	473,000	0	0
Soda ash or alkali . . .	74,000	11	0	0	814,000	0	0
Caustic soda, 70 per cent.	3,720	26	0	0	96,720	0	0
Bicarbonate of soda . . .	11,000	18	0	0	198,000	0	0
Sulphate of soda	2,400	4	5	0	10,200	0	0
Bleaching powder	27,000	14	0	0	278,000	0	0
Epsom salts	590	8	0	0	4,720	0	0
Glauber salts	20	6	15	0	135	0	0
Sulphate of copper	200	26	0	0	5,200	0	0
Hyposulphite of soda . . .	400	18	0	0	7,200	0	0
Chloride of manganese . . .	1,300	3	10	0	4,550	0	0
Oil of vitriol for sale . . .	9,000	4	0	0	36,000	0	0
Muriatic acid	700	3	0	0	2,100	0	0
Total tons	216,330	Total value			1,929,825	0	0

Thus it will be seen that the extent of the alkali trade in the two great districts of Lancashire and the Tyne was nearly equal in terms of production and value. In regard to the Tyne district (1867), the raw materials consumed for producing the above quantities consisted of pyrites, salt, chalk, timber, coal, and manganese, and amounted to 1,070,000 tons, with an aggregate value of 830,925*l.*

‘The number of workmen employed in the soda works on the Tyne is estimated to be 8,000; and the number of vessels which discharged cargoes of raw materials at soda works in 1867 was 5,000. The floating and fixed capital employed in soda works on the Tyne is 2,000,000*l.* to 2,500,000*l.*’ (R. Calvert Clapham.)

Taking the raw materials consumed in Lancashire to have had a total value of about 869,600*l.* in 1866–67, we get the following computation for the whole of England in that year:—Raw materials, 1,700,525*l.*; manufactured ditto, 3,936,829*l.*; capital, 5,000,000*l.*

Since the year of which we have been writing, no very reliable statistics are forthcoming for the collective trade; but we know that the production of particular articles has undergone a large increase—notably, caustic soda and bleaching powder. Indeed, the production of the latter article has more than doubled; while sulphur regenerated from the alkali waste and certain other regenerated substances, have to be added to the list of manufactured articles. The manufacture of the specialties of the Tyne district—sulphate of copper and hypsulphite of soda—has diminished.

Apart from exact statistics, it has been calculated that the decomposition of salt in the Tyne district during 1874, exceed 202,000 tons, and as it has also undergone an increase in the Lancashire district, perhaps it may be said that about 500,000 tons of salt are now annually consumed in Great Britain. It must not be forgotten that the Glasgow chemical industry is very large, and further on, we shall again allude to it.

The following figures show the state of the Tyne alkali trade in 1874, and in connection with this matter it should be remembered that it gives rise to a large shipping trade in addition.

Inwards to the extent of	622,000 tons
Coals (only a small part by shipping)	800,000 „
	<u>1,422,000 „</u>
Outwards, including packages	382,000 „
Totals	<u>1,804,000 „</u>
Value of raw materials	£1,600,000
Computed value of manufactured goods	£2,630,000
Weight in tons of manufactured goods	382,000
Weight carried in all by sea and rail	2,126,000 tons

These weights and values do not include the materials used in buildings, plants, and repairs, which, from

LONDON : PRINTED BY
SPOTTISWOODE AND CO., NEW-STREET SQUARE
AND PARLIAMENT STREET

CATALOGUE
OF
Practical and Scientific Books
PUBLISHED BY
HENRY CAREY BAIRD & CO.

INDUSTRIAL PUBLISHERS, BOOKSELLERS AND IMPORTERS.

810 Walnut Street, Philadelphia.

Any of the Books comprised in this Catalogue will be sent by mail, free of postage, to any address in the world, at the publication prices.

A Descriptive Catalogue, 84 pages, 8vo., will be sent free and free of postage, to any one in any part of the world, who will furnish his address.

Where not otherwise stated, all of the Books in this Catalogue are bound in muslin.

AMATEUR MECHANICS' WORKSHOP:

A treatise containing plain and concise directions for the manipulation of Wood and Metals, including Casting, Forging, Brazing, Soldering and Carpentry. By the author of the "Lathe and Its Uses." Seventh edition. Illustrated. 8vo. . . . \$2.50

ANDRES.—A Practical Treatise on the Fabrication of Volatile and Fat Varnishes, Lacquers, Siccatives and Sealing Waxes.

From the German of ERWIN ANDRES, Manufacturer of Varnishes and Lacquers. With additions on the Manufacture and Application of Varnishes, Stains for Wood, Horn, Ivory, Bone and Leather. From the German of DR. EMIL WINCKLER and LOUIS E. ANDES. The whole translated and edited by WILLIAM T. BRANNT. With 11 illustrations. 12mo. . . . \$2.50

ARLOT.—A Complete Guide for Coach Painters:

Translated from the French of M. ARLOT, Coach Painter, for eleven years Foreman of Painting to M. Eherler, Coach Maker, Paris. By A. A. FESQUET, Chemist and Engineer. To which is added an Appendix, containing Information respecting the Materials and the Practice of Coach and Car Painting and Varnishing in the United States and Great Britain. 12mo. . . . \$1.25

ARMENGAUD, AMOROUX, AND JOHNSON.—The Practical Draughtsman's Book of Industrial Design, and Machinist's and Engineer's Drawing Companion :

Forming a Complete Course of Mechanical Engineering and Architectural Drawing. From the French of M. Armengaud the elder, Prof. of Design in the Conservatoire of Arts and Industry, Paris, and MM. Armengaud the younger, and Amoroux, Civil Engineers. Rewritten and arranged with additional matter and plates, selections from and examples of the most useful and generally employed mechanism of the day. By WILLIAM JOHNSON, Assoc. Inst. C. E. Illustrated by fifty folio steel plates, and fifty wood-cuts. A new edition, 4to., half morocco \$10.00

ARMSTRONG.—The Construction and Management of Steam Boilers :

By R. ARMSTRONG, C. E. With an Appendix by ROBERT MALLET, C. E., F. R. S. Seventh Edition. Illustrated. 1 vol. 12mo. 75

ARROWSMITH.—Paper-Hanger's Companion :

A Treatise in which the Practical Operations of the Trade are Systematically laid down: with Copious Directions Preparatory to Papering; Preventives against the Effect of Damp on Walls; the various Cements and Pastes Adapted to the Several Purposes of the Trade; Observations and Directions for the Panelling and Ornamenting of Rooms, etc. By JAMES ARROWSMITH. 12mo., cloth \$1.25

ASHTON.—The Theory and Practice of the Art of Designing Fancy Cotton and Woollen Cloths from Sample :

Giving full instructions for reducing drafts, as well as the methods of spooling and making out harness for cross drafts and finding any required reed; with calculations and tables of yarn. By FREDERIC T. ASHTON, Designer, West Pittsfield, Mass. With fifty-two illustrations. One vol. folio \$6.00

ASKINSON.—Perfumes and their Preparation :

A Comprehensive Treatise on Perfumery, containing Complete Directions for Making Handkerchief Perfumes, Smelling-Salts, Sachets, Fumigating Pastils; Preparations for the Care of the Skin, the Mouth, the Hair; Cosmetics, Hair Dyes, and other Toilet Articles. By G.W. ASKINSON. Translated from the German by ISIDOR FURST. Revised by CHARLES RICE. 32 Illustrations. 8vo. \$3.00

BAIRD.—Miscellaneous Papers on Economic Questions. By Henry Carey Baird. (*In preparation.*)

BAIRD.—The American Cotton Spinner, and Manager's and Carder's Guide :

A Practical Treatise on Cotton Spinning; giving the Dimensions and Speed of Machinery, Draught and Twist Calculations, etc.; with notices of recent Improvements: together with Rules and Examples for making changes in the sizes and numbers of Roving and Yarn. Compiled from the papers of the late ROBERT H. BAIRD. 12mo. \$1.50

BAIRD.—Standard Wages Computing Tables :

An Improvement in all former Methods of Computation, so arranged that wages for days, hours, or fractions of hours, at a specified rate per day or hour, may be ascertained at a glance. By T. SPANGLER BAIRD. Oblong folio \$5.00

BAKER.—Long-Span Railway Bridges :

Comprising Investigations of the Comparative Theoretical and Practical Advantages of the various Adopted or Proposed Type Systems of Construction; with numerous Formulæ and Tables. By B. BAKER. 12mo. \$1.50

BAKER.—The Mathematical Theory of the Steam-Engine :

With Rules at length, and Examples worked out for the use of Practical Men. By T. BAKER, C. E., with numerous Diagrams. Sixth Edition, Revised by Prof. J. R. YOUNG. 12mo. 75

BARLOW.—The History and Principles of Weaving, by Hand and by Power :

Reprinted, with Considerable Additions, from "Engineering," with a chapter on Lace-making Machinery, reprinted from the Journal of the "Society of Arts." By ALFRED BARLOW. With several hundred illustrations. 8vo., 443 pages \$10.00

BARR.—A Practical Treatise on the Combustion of Coal :

Including descriptions of various mechanical devices for the Economic Generation of Heat by the Combustion of Fuel, whether solid, liquid or gaseous. 8vo. \$2.50

BARR.—A Practical Treatise on High Pressure Steam Boilers :

Including Results of Recent Experimental Tests of Boiler Materials, together with a Description of Approved Safety Apparatus, Steam Pumps, Injectors and Economizers in actual use. By WM. M. BARR. 204 Illustrations. 8vo. \$3.00

BAUERMAN.—A Treatise on the Metallurgy of Iron :

Containing Outlines of the History of Iron Manufacture, Methods of Assay, and Analysis of Iron Ores, Processes of Manufacture of Iron and Steel, etc., etc. By H. BAUERMAN, F. G. S., Associate of the Royal School of Mines. Fifth Edition, Revised and Enlarged. Illustrated with numerous Wood Engravings from Drawings by J. B. JORDAN. 12mo. \$2.00

BAYLES.—House Drainage and Water Service :

In Cities, Villages and Rural Neighborhoods. With Incidental Consideration of Certain Causes Affecting the Healthfulness of Dwellings. By JAMES C. BAYLES, Editor of "The Iron Age" and "The Metal Worker." With numerous illustrations. 8vo. cloth,

BEANS.—A Treatise on Railway Curves and Location of Railroads :

By E. W. BEANS, C. E. Illustrated. 12mo. Tucks \$1.50

BECKETT.—A Rudimentary Treatise on Clocks, and Watches and Bells :

By Sir EDMUND BECKETT, Bart., LL. D., Q. C. F. R. A. S. With numerous illustrations. Seventh Edition, Revised and Enlarged. 12mo. \$2.25

BELL.—Carpentry Made Easy :

Or, The Science and Art of Framing on a New and Improved System. With Specific Instructions for Building Balloon Frames, Barn Frames, Mill Frames, Warehouses, Church Spires, etc. Comprising also a System of Bridge Building, with Bills, Estimates of Cost, and valuable Tables. Illustrated by forty-four plates, comprising nearly 200 figures. By WILLIAM E. BELL, Architect and Practical Builder. 8vo. \$5.00

BEMROSE.—Fret-Cutting and Perforated Carving :

With fifty-three practical illustrations. By W. BEMROSE, JR. 1 vol. quarto \$2.50

BEMROSE.—Manual of Buhl-work and Marquetry :

With Practical Instructions for Learners, and ninety colored designs. By W. BEMROSE, JR. 1 vol. quarto \$3.00

BEMROSE.—Manual of Wood Carving :

With Practical Illustrations for Learners of the Art, and Original and Selected Designs. By WILLIAM BEMROSE, JR. With an Introduction by LEWELLYN JEWITT, F. S. A., etc. With 128 illustrations, 4to. \$2.50

BILLINGS.—Tobacco :

Its History, Variety, Culture, Manufacture, Commerce, and Various Modes of Use. By E. R. BILLINGS. Illustrated by nearly 200 engravings. 8vo. \$3.00

BIRD.—The American Practical Dyers' Companion :

Comprising a Description of the Principal Dye-Stuffs and Chemicals used in Dyeing, their Natures and Uses; Mordants, and How Made; with the best American, English, French and German processes for Bleaching and Dyeing Silk, Wool, Cotton, Linen, Flannel, Felt, Dress Goods, Mixed and Hosiery Yarns, Feathers, Grass, Felt, Fur, Wool, and Straw Hats, Jute Yarn, Vegetable Ivory, Mats, Skins, Furs, Leather, etc., etc. By Wood, Aniline, and other Processes, together with Remarks on Finishing Agents, and Instructions in the Finishing of Fabrics, Substitutes for Indigo, Water-Proofing of Materials, Tests and Purification of Water, Manufacture of Aniline and other New Dye Wares, Harmonizing Colors, etc., etc.; embracing in all over 800 Receipts for Colors and Shades, accompanied by 170 Dyed Samples of Raw Materials and Fabrics. By F. J. BIRD, Practical Dyer, Author of "The Dyers' Hand-Book." 8vo. \$10.00

BLINN.—A Practical Workshop Companion for Tin, Sheet-Iron, and Copper-plate Workers :

Containing Rules for describing various kinds of Patterns used by Tin, Sheet-Iron and Copper-plate Workers; Practical Geometry; Mensuration of Surfaces and Solids; Tables of the Weights of Metals, Lead-pipe, etc.; Tables of Areas and Circumferences of Circles; Japan, Varnishes, Lackers, Cements, Compositions, etc., etc. By LEROY J. BLINN, Master Mechanic. With One Hundred and Seventy Illustrations. 12mo. \$2.50

BOOTH.—Marble Worker's Manual :

Containing Practical Information respecting Marbles in general, their Cutting, Working and Polishing; Veneering of Marble; Mosaics; Composition and Use of Artificial Marble, Stuccos, Cements, Receipts, Secrets, etc., etc. Translated from the French by M. L. BOOTH. With an Appendix concerning American Marbles. 12mo., cloth \$1.50

BOOTH and MORFIT.—The Encyclopædia of Chemistry, Practical and Theoretical :

Embracing its application to the Arts, Metallurgy, Mineralogy, Geology, Medicine and Pharmacy. By JAMES C. BOOTH, Melter and Refiner in the United States Mint, Professor of Applied Chemistry in the Franklin Institute, etc., assisted by CAMPBELL MORFIT, author of "Chemical Manipulations," etc. Seventh Edition. Complete in one volume, royal 8vo., 978 pages, with numerous wood-cuts and other illustrations \$3.50

BRAMWELL.—The Wool Carder's Vade-Mecum :

A Complete Manual of the Art of Carding Textile Fabrics. By W. C. BRAMWELL. Third Edition, revised and enlarged. Illustrated. Pp. 400. 12mo. \$2.50

BRANNT.—A Practical Treatise on Animal and Vegetable Fats and Oils :

Comprising both Fixed and Volatile Oils, their Physical and Chemical Properties and Uses, the Manner of Extracting and Refining them, and Practical Rules for Testing them; as well as the Manufacture of Artificial Butter, Lubricants, including Mineral Lubricating Oils, etc., and on Ozokerite. Edited chiefly from the German of DRs. KARL SCHAEGLER, G. W. ASKINSON, and RICHARD BRUNNER, with Additions and Lists of American Patents relating to the Extraction, Rendering, Refining, Decomposing, and Bleaching of Fats and Oils. By WILLIAM T. BRANNT. Illustrated by 244 engravings. 739 pages. 8vo. \$7.50

BRANNT.—A Practical Treatise on the Manufacture of Soap and Candles :

Based upon the most Recent Experiences in the Practice and Science; comprising the Chemistry, Raw Materials, Machinery, and Utensils and Various Processes of Manufacture, including a great variety of formulas. Edited chiefly from the German of Dr. C. Deite, A. Engelhardt, Dr. C. Schaedler and others; with additions and lists of American Patents relating to these subjects. By WM. T. BRANNT. Illustrated by 163 engravings. 677 pages. 8vo. \$7.50

BRANNT.—A Practical Treatise on the Raw Materials and the Distillation and Rectification of Alcohol, and the Preparation of Alcoholic Liquors, Liqueurs, Cordials, Bitters, etc. :

Edited chiefly from the German of Dr. K. Stammer, Dr. F. Elsner, and E. Schubert. By WM. T. BRANNT. Illustrated by thirty-one engravings. 12mo. \$2.50

BRANNT—WAHL.—The Techno-Chemical Receipt Book :

Containing several thousand Receipts covering the latest, most important, and most useful discoveries in Chemical Technology, and their Practical Application in the Arts and the Industries. Edited chiefly from the German of Drs. Winckler, Elsner, Heintze, Mierzinski, Jacobsen, Koller, and Heinzerling, with additions by WM. J. BRANNT and WM. H. WAHL, PH. D. Illustrated by 78 engravings.
12mo. 495 pages \$2 00

BROWN.—Five Hundred and Seven Mechanical Movements.

Embracing all those which are most important in Dynamics, Hydraulics, Hydrostatics, Pneumatics, Steam-Engines, Mill and other Gearing, Presses, Horology and Miscellaneous Machinery; and including many movements never before published, and several of which have only recently come into use. By HENRY T. BROWN.
12mo. \$1.00

BUCKMASTER.—The Elements of Mechanical Physics :

By J. C. BUCKMASTER. Illustrated with numerous engravings.
12mo. \$1.00

BULLOCK.—The American Cottage Builder :

A Series of Designs, Plans and Specifications, from \$200 to \$20,000, for Homes for the People; together with Warming, Ventilation, Drainage, Painting and Landscape Gardening. By JOHN BULLOCK, Architect and Editor of "The Rudiments of Architecture and Building," etc., etc. Illustrated by 75 engravings. 8vo. \$3.50

BULLOCK.—The Rudiments of Architecture and Building :

For the use of Architects, Builders, Draughtsmen, Machinists, Engineers and Mechanics. Edited by JOHN BULLOCK, author of "The American Cottage Builder." Illustrated by 250 Engravings. 8vo. \$3.50

BURGH.—Practical Rules for the Proportions of Modern Engines and Boilers for Land and Marine Purposes.

By N. P. BURGH, Engineer. 12mo. \$1.50

BYLES.—Sophisms of Free Trade and Popular Political Economy Examined.

By a BARRISTER (SIR JOHN BARNARD BYLES, Judge of Common Pleas). From the Ninth English Edition, as published by the Manchester Reciprocity Association. 12mo. \$1.25

BOWMAN.—The Structure of the Wool Fibre in its Relation to the Use of Wool for Technical Purposes :

Being the substance, with additions, of Five Lectures, delivered at the request of the Council, to the members of the Bradford Technical College, and the Society of Dyers and Colorists. By F. H. BOWMAN, D. Sc., F. R. S. E., F. L. S. Illustrated by 32 engravings.
8vo. \$6.50

BYRNE.—Hand-Book for the Artisan, Mechanic, and Engineer :

Comprising the Grinding and Sharpening of Cutting Tools, Abrasive Processes, Lapidary Work, Gem and Glass Engraving, Varnishing and Lacking, Apparatus, Materials and Processes for Grinding and

- Polishing, etc. By OLIVER BYRNE. Illustrated by 185 wood engravings. 8vo. \$5.00
- BYRNE.—Pocket-Book for Railroad and Civil Engineers:**
Containing New, Exact and Concise Methods for Laying out Railroad Curves, Switches, Frog Angles and Crossings; the Staking out of work; Levelling; the Calculation of Cuttings; Embankments; Earthwork, etc. By OLIVER BYRNE. 18mo., full bound, pocket-book form \$1.75
- BYRNE.—The Practical Metal-Worker's Assistant:**
Comprising Metallurgic Chemistry; the Arts of Working all Metals and Alloys; Forging of Iron and Steel; Hardening and Tempering; Melting and Mixing; Casting and Founding; Works in Sheet Metal; the Processes Dependent on the Ductility of the Metals; Soldering; and the most Improved Processes and Tools employed by Metal-Workers. With the Application of the Art of Electro-Metallurgy to Manufacturing Processes; collected from Original Sources, and from the works of Holtzapffel, Bergeron, Leupold, Plumier, Napier, Scoffern, Clay, Fairbairn and others. By OLIVER BYRNE. A new, revised and improved edition, to which is added an Appendix, containing The Manufacture of Russian Sheet-Iron. By JOHN PERCY, M. D., F. R. S. The Manufacture of Malleable Iron Castings, and Improvements in Bessemer Steel. By A. A. FESQUET, Chemist and Engineer. With over Six Hundred Engravings, Illustrating every Branch of the Subject. 8vo. \$5.00
- BYRNE.—The Practical Model Calculator:**
For the Engineer, Mechanic, Manufacturer of Engine Work, Naval Architect, Miner and Millwright. By OLIVER BYRNE. 8vo., nearly 600 pages \$4.50
- CABINET MAKER'S ALBUM OF FURNITURE:**
Comprising a Collection of Designs for various Styles of Furniture. Illustrated by Forty-eight Large and Beautifully Engraved Plates. Oblong, 8vo. \$2.00
- CALLINGHAM.—Sign Writing and Glass Embossing:**
A Complete Practical Illustrated Manual of the Art. By JAMES CALLINGHAM. 12mo. \$1.50
- CAMPIN.—A Practical Treatise on Mechanical Engineering:**
Comprising Metallurgy, Moulding, Casting, Forging, Tools, Workshop Machinery, Mechanical Manipulation, Manufacture of Steam-Engines, etc. With an Appendix on the Analysis of Iron and Iron Ores. By FRANCIS CAMPIN, C. E. To which are added, Observations on the Construction of Steam Boilers, and Remarks upon Furnaces used for Smoke Prevention; with a Chapter on Explosions. By R. ARMSTRONG, C. E., and JOHN BOURNE. Rules for Calculating the Change Wheels for Screws on a Turning Lathe, and for a Wheel-cutting Machine. By J. LA NICCA. Management of Steel, Including Forging, Hardening, Tempering, Annealing, Shrinking and Expansion; and the Case-hardening of Iron. By G. EDE. 8vo. Illustrated with twenty-nine plates and 100 wood engravings . . . \$5.00

CAREY.—A Memoir of Henry C. Carey.

By DR. WM. ELDER. With a portrait. 8vo., cloth . . . 75

CAREY.—The Works of Henry C. Carey:**Harmony of Interests: Agricultural, Manufacturing and Commercial.** 8vo. . . . \$1.25**Manual of Social Science.** Condensed from Carey's "Principles of Social Science." By KATE MCKEAN. 1 vol. 12mo. . . \$2.25**Miscellaneous Works.** With a Portrait. 2 vols. 8vo. . . \$10.00**Past, Present and Future.** 8vo. . . . \$2.50**Principles of Social Science.** 3 volumes, 8vo. . . . \$7.50**The Slave-Trade, Domestic and Foreign; Why it Exists, and How it may be Extinguished (1853).** 8vo. . . . \$2.00**The Unity of Law: As Exhibited in the Relations of Physical, Social, Mental and Moral Science (1872).** 8vo. . . . \$2.50**CLARK.—Tramways, their Construction and Working:**

Embracing a Comprehensive History of the System. With an exhaustive analysis of the various modes of traction, including horse-power, steam, heated water and compressed air; a description of the varieties of Rolling stock, and ample details of cost and working expenses. By D. KINNEAR CLARK. Illustrated by over 200 wood engravings, and thirteen folding plates. 2 vols. 8vo. . . \$12.50

COLBURN.—The Locomotive Engine:

Including a Description of its Structure, Rules for Estimating its Capabilities, and Practical Observations on its Construction and Management. By ZERAH COLBURN. Illustrated. 12mo. . . \$1.00

COLLENS.—The Eden of Labor; or, the Christian Utopia.

By T. WHARTON COLLENS, author of "Humanics," "The History of Charity," etc. 12mo. Paper cover, \$1.00; Cloth . . . \$1.25

COOLEY.—A Complete Practical Treatise on Perfumery:

Being a Hand-book of Perfumes, Cosmetics and other Toilet Articles. With a Comprehensive Collection of Formulæ. By ARNOLD J COOLEY. 12mo. . . . \$1.50

COOPER.—A Treatise on the use of Belting for the Transmission of Power.

With numerous illustrations of approved and actual methods of arranging Main Driving and Quarter Twist Belts, and of Belt Fastenings. Examples and Rules in great number for exhibiting and calculating the size and driving power of Belts. Plain, Particular and Practical Directions for the Treatment, Care and Management of Belts. Descriptions of many varieties of Beltings, together with chapters on the Transmission of Power by Ropes; by Iron and Wood Frictional Gearing; on the Strength of Belting Leather; and on the Experimental Investigations of Morin, Briggs, and others. By JOHN H. COOPER, M. E. 8vo. . . . \$3.50

CRAIK.—The Practical American Millwright and Miller.

By DAVID CRAIK, Millwright. Illustrated by numerous wood engravings and two folding plates. 8vo. . . . \$3.50

CREW.—A Practical Treatise on Petroleum :

Comprising its Origin, Geology, Geographical Distribution, History, Chemistry, Mining, Technology, Uses and Transportation. Together with a Description of Gas Wells, the Application of Gas as Fuel, etc. By BENJAMIN J. CREW. With an Appendix on the Product and Exhaustion of the Oil Regions, and the Geology of Natural Gas in Pennsylvania and New York. By CHARLES A. ASHBURNER, M. S., Geologist in Charge Pennsylvania Survey, Philadelphia. Illustrated by 70 engravings. 8vo. 508 pages \$5.00

CROSS.—The Cotton Yarn Spinner :

Showing how the Preparation should be arranged for Different Counts of Yarns by a System more uniform than has hitherto been practiced; by having a Standard Schedule from which we make all our Changes. By RICHARD CROSS. 122 pp. 12mo. . . . 75

CRISTIANI.—A Technical Treatise on Soap and Candles :

With a Glance at the Industry of Fats and Oils. By R. S. CRISTIANI, Chemist. Author of "Perfumery and Kindred Arts." Illustrated by 176 engravings. 581 pages, 8vo. . . . \$15.00

CRISTIANI.—Perfumery and Kindred Arts :

A Comprehensive Treatise on Perfumery, containing a History of Perfumes from the remotest ages to the present time. A complete detailed description of the various Materials and Apparatus used in the Perfumer's Art, with thorough Practical Instruction and careful Formulæ, and advice for the fabrication of all known preparations of the day, including Essences, Tinctures, Extracts, Spirits, Waters, Vinegars, Pomades, Powders, Paints, Oils, Emulsions, Cosmetics, Infusions, Pastilles, Tooth Powders and Washes, Cachous, Hair Dyes, Sachets, Essential Oils, Flavoring Extracts, etc.; and full details for making and manipulating Fancy Toilet Soaps, Shaving Creams, etc., by new and improved methods. With an Appendix giving hints and advice for making and fermenting Domestic Wines, Cordials, Liquors, Candies, Jellies, Syrups, Colors, etc., and for Perfuming and Flavoring Segars, Snuff and Tobacco, and Miscellaneous Receipts for various useful Analogous Articles. By R. S. CRISTIANI, Consulting Chemist and Perfumer, Philadelphia. 8vo. . . . \$10.00

**DAVIDSON.—A Practical Manual of House Painting, Grain-
ing, Marbling, and Sign-Writing :**

Containing full information on the processes of House Painting in Oil and Distemper, the Formation of Letters and Practice of Sign-Writing, the Principles of Decorative Art, a Course of Elementary Drawing for House Painters, Writers, etc., and a Collection of Useful Receipts. With nine colored illustrations of Woods and Marbles, and numerous wood engravings. By ELLIS A. DAVIDSON. 12mo. \$3.00

**DAVIES.—A Treatise on Earthy and Other Minerals and
Mining :**

By D. C. DAVIES, F. G. S., Mining Engineer, etc. Illustrated by 76 Engravings. 12mo. . . . \$5.00

- DAVIES.—A Treatise on Metalliferous Minerals and Mining:**
By D. C. DAVIES, F. G. S., Mining Engineer, Examiner of Mines, Quarries and Collieries. Illustrated by 148 engravings of Geological Formations, Mining Operations and Machinery, drawn from the practice of all parts of the world. 2d Edition, 12mo., 450 pages \$5.00
- DAVIES.—A Treatise on Slate and Slate Quarrying:**
Scientific, Practical and Commercial. By D. C. DAVIES, F. G. S., Mining Engineer, etc. With numerous illustrations and folding plates. 12mo. \$2.00
- DAVIS.—A Treatise on Steam-Boiler Incrustation and Methods for Preventing Corrosion and the Formation of Scale:**
By CHARLES T. DAVIS. Illustrated by 65 engravings. 8vo. \$1.50
- DAVIS.—The Manufacture of Paper:**
Being a Description of the various Processes for the Fabrication, Coloring and Finishing of every kind of Paper, Including the Different Raw Materials and the Methods for Determining their Values, the Tools, Machines and Practical Details connected with an intelligent and a profitable prosecution of the art, with special reference to the best American Practice. To which are added a History of Paper, complete Lists of Paper-Making Materials, List of American Machines, Tools and Processes used in treating the Raw Materials, and in Making, Coloring and Finishing Paper. By CHARLES T. DAVIS. Illustrated by 156 engravings. 608 pages, 8vo. \$6.00
- DAVIS.—The Manufacture of Leather:**
Being a description of all of the Processes for the Tanning, Tawing, Currying, Finishing and Dyeing of every kind of Leather; including the various Raw Materials and the Methods for Determining their Values; the Tools, Machines, and all Details of Importance connected with an Intelligent and Profitable Prosecution of the Art, with Special Reference to the Best American Practice. To which are added Complete Lists of all American Patents for Materials, Processes, Tools, and Machines for Tanning, Currying, etc. By CHARLES THOMAS DAVIS. Illustrated by 302 engravings and 12 Samples of Dyed Leathers. One vol., 8vo., 824 pages \$10.00
- DAWIDOWSKY—BRANNT.—A Practical Treatise on the Raw Materials and Fabrication of Glue, Gelatine, Gelatine Veneers and Foils, Isinglass, Cements, Pastes, Mucilages, etc.:**
Based upon Actual Experience. By F. DAWIDOWSKY, Technical Chemist. Translated from the German, with extensive additions, including a description of the most Recent American Processes, by WILLIAM T. BRANNT, Graduate of the Royal Agricultural College of Eldena, Prussia. 35 Engravings. 12mo. . . . \$2.50
- DE GRAFF.—The Geometrical Stair-Builders' Guide:**
Being a Plain Practical System of Hand-Railing, embracing all its necessary Details, and Geometrically Illustrated by twenty-two Steel Engravings; together with the use of the most approved principles of Practical Geometry. By SIMON DE GRAFF, Architect. 4to. \$2.00

DE KONINCK—DIETZ.—A Practical Manual of Chemical Analysis and Assaying:

As applied to the Manufacture of Iron from its Ores, and to Cast Iron, Wrought Iron, and Steel, as found in Commerce. By L. L. DE KONINCK, Dr. Sc., and E. DIETZ, Engineer. Edited with Notes, by ROBERT MALLET, F. R. S., F. S. G., M. I. C. E., etc. American Edition, Edited with Notes and an Appendix on Iron Ores, by A. A. FESQUET, Chemist and Engineer. 12mo. . . . \$2.50

DUNCAN.—Practical Surveyor's Guide:

Containing the necessary information to make any person of common capacity, a finished land surveyor without the aid of a teacher By ANDREW DUNCAN. Revised. 72 engravings, 214 pp. 12mo. \$1.50

DUPLAIS.—A Treatise on the Manufacture and Distillation of Alcoholic Liquors:

Comprising Accurate and Complete Details in Regard to Alcohol from Wine, Molasses, Beets, Grain, Rice, Potatoes, Sorghum, Asphodel, Fruits, etc.; with the Distillation and Rectification of Brandy, Whiskey, Rum, Gin, Swiss Absinthe, etc., the Preparation of Aromatic Waters, Volatile Oils or Essences, Sugars, Syrups, Aromatic Tinctures, Liqueurs, Cordial Wines, Effervescing Wines, etc., the Ageing of Brandy and the improvement of Spirits, with Copious Directions and Tables for Testing and Reducing Spirituous Liquors, etc., etc. Translated and Edited from the French of MM. DUPLAIS, Ainé et Jeune. By M. MCKENNIE, M. D. To which are added the United States Internal Revenue Regulations for the Assessment and Collection of Taxes on Distilled Spirits. Illustrated by fourteen folding plates and several wood engravings. 743 pp. 8vo. \$10 00

DUSSAUCE.—Practical Treatise on the Fabrication of Matches, Gun Cotton, and Fulminating Powder.

By Professor H. DUSSAUCE. 12mo. . . . \$3 00

DYER AND COLOR-MAKER'S COMPANION:

Containing upwards of two hundred Receipts for making Colors, on the most approved principles, for all the various styles and fabrics now in existence; with the Scouring Process, and plain Directions for Preparing, Washing-off, and Finishing the Goods. 12mo. \$1 25

EDWARDS.—A Catechism of the Marine Steam-Engine,

For the use of Engineers, Firemen, and Mechanics. A Practical Work for Practical Men. By EMORY EDWARDS, Mechanical Engineer. Illustrated by sixty-three Engravings, including examples of the most modern Engines. Third edition, thoroughly revised, with much additional matter. 12mo. 414 pages . . . \$2 00

EDWARDS.—Modern American Locomotive Engines,

Their Design, Construction and Management. By EMORY EDWARDS. Illustrated 12mo. . . . \$2.00

EDWARDS.—The American Steam Engineer:

Theoretical and Practical, with examples of the latest and most approved American practice in the design and construction of Steam Engines and Boilers. For the use of engineers, machinists, boiler-makers, and engineering students. By EMORY EDWARDS. Fully illustrated, 419 pages. 12mo. . . . \$2.50

- EDWARDS.—Modern American Marine Engines, Boilers, and Screw Propellers,**
 Their Design and Construction. Showing the Present Practice of the most Eminent Engineers and Marine Engine Builders in the United States. Illustrated by 30 large and elaborate plates. 4to. \$5.00
- EDWARDS.—The Practical Steam Engineer's Guide**
 In the Design, Construction, and Management of American Stationary, Portable, and Steam Fire-Engines, Steam Pumps, Boilers, Injectors, Governors, Indicators, Pistons and Rings, Safety Valves and Steam Gauges. For the use of Engineers, Firemen, and Steam Users. By EMORY EDWARDS. Illustrated by 119 engravings. 420 pages. 12mo. \$2 50
- EISSLER.—The Metallurgy of Gold :**
 A Practical Treatise on the Metallurgical Treatment of Gold-Bearing Ores, including the Processes of Concentration and Chlorination, and the Assaying, Melting, and Refining of Gold. By M. EISSLER. With 132 Illustrations. 12mo. \$3.50
- EISSLER.—The Metallurgy of Silver :**
 A Practical Treatise on the Amalgamation, Roasting, and Lixiviation of Silver Ores, including the Assaying, Melting, and Refining of Silver Bullion. By M. EISSLER. 124 Illustrations. 336 pp. 12mo. \$4.25
- ELDER.—Conversations on the Principal Subjects of Political Economy.**
 By DR. WILLIAM ELDER. 8vo. \$2.50
- ELDER.—Questions of the Day,**
 Economic and Social. By DR. WILLIAM ELDER. 8vo. \$3.00
- ERNI.—Mineralogy Simplified.**
 Easy Methods of Determining and Classifying Minerals, including Ores, by means of the Blowpipe, and by Humid Chemical Analysis, based on Professor von Kobell's Tables for the Determination of Minerals, with an Introduction to Modern Chemistry. By HENRY ERNI, A. M., M. D., Professor of Chemistry. Second Edition, rewritten, enlarged and improved. 12mo. \$3.00
- FAIRBAIRN.—The Principles of Mechanism and Machinery of Transmission .**
 Comprising the Principles of Mechanism, Wheels, and Pulleys, Strength and Proportions of Shafts, Coupling of Shafts, and Engaging and Disengaging Gear. By SIR WILLIAM FAIRBAIRN, Bart. C. E. Beautifully illustrated by over 150 wood-cuts. In one volume, 12mo \$2.50
- FLEMING.—Narrow Gauge Railways in America.**
 A Sketch of their Rise, Progress, and Success. Valuable Statistics as to Grades, Curves, Weight of Rail, Locomotives, Cars, etc. By HOWARD FLEMING. Illustrated, 8vo. \$1 00
- FORSYTH.—Book of Designs for Headstones, Mural, and other Monuments :**
 Containing 78 Designs. By JAMES FORSYTH. With an Introduction by CHARLES BOUTELL, M. A. 4 to., cloth \$5 00

FRANKEL—HUTTER.—A Practical Treatise on the Manufacture of Starch, Glucose, Starch-Sugar, and Dextrine:

Based on the German of LADISLAUS VON WAGNER, Professor in the Royal Technical High School, Buda-Pest, Hungary, and other authorities. By JULIUS FRANKEL, Graduate of the Polytechnic School of Hanover. Edited by ROBERT HUTTER, Chemist, Practical Manufacturer of Starch-Sugar. Illustrated by 58 engravings, covering every branch of the subject, including examples of the most Recent and Best American Machinery. 8vo., 344 pp. . \$3.50

GARDNER.—The Painter's Encyclopædia:

Containing Definitions of all Important Words in the Art of Plain and Artistic Painting, with Details of Practice in Coach, Carriage, Railway Car, House, Sign, and Ornamental Painting, including Graining, Marbling, Staining, Varnishing, Polishing, Lettering, Stenciling, Gilding, Bronzing, etc. By FRANKLIN B. GARDNER. 158 Illustrations. 12mo. 427 pp. \$2.00

GARDNER.—Everybody's Paint Book:

A Complete Guide to the Art of Outdoor and Indoor Painting, Designed for the Special Use of those who wish to do their own work, and consisting of Practical Lessons in Plain Painting, Varnishing, Polishing, Staining, Paper Hanging, Kalsomining, etc., as well as Directions for Renovating Furniture, and Hints on Artistic Work for Home Decoration. 38 Illustrations. 12mo., 183 pp. . \$1.00

GEE.—The Goldsmith's Handbook:

Containing full instructions for the Alloying and Working of Gold, including the Art of Alloying, Melting, Reducing, Coloring, Collecting, and Refining; the Processes of Manipulation, Recovery of Waste; Chemical and Physical Properties of Gold; with a New System of Mixing its Alloys; Solders, Enamels, and other Useful Rules and Recipes. By GEORGE E. GEE. 12mo. . . . \$1.75

GEE.—The Silversmith's Handbook:

Containing full instructions for the Alloying and Working of Silver, including the different modes of Refining and Melting the Metal; its Solders; the Preparation of Imitation Alloys; Methods of Manipulation; Prevention of Waste; Instructions for Improving and Finishing the Surface of the Work; together with other Useful Information and Memoranda. By GEORGE E. GEE. Illustrated. 12mo. \$1.75

GOTHIC ALBUM FOR CABINET-MAKERS:

Designs for Gothic Furniture. Twenty-three plates. Oblong \$2.00

GRANT.—A Handbook on the Teeth of Gears:

Their Curves, Properties, and Practical Construction. By GEORGE B. GRANT. Illustrated. Third Edition, enlarged. 8vo. \$1.00

GREENWOOD.—Steel and Iron:

Comprising the Practice and Theory of the Several Methods Pursued in their Manufacture, and of their Treatment in the Rolling-Mills, the Forge, and the Foundry. By WILLIAM HENRY GREENWOOD, F. C. S. With 97 Diagrams, 536 pages. 12mo. \$2.00

GREGORY.—Mathematics for Practical Men :

Adapted to the Pursuits of Surveyors, Architects, Mechanics, and Civil Engineers. By OLINTHUS GREGORY. 8vo., plates \$3.00

GRIMSHAW.—Saws :

The History, Development, Action, Classification, and Comparison of Saws of all kinds. *With Copious Appendices.* Giving the details of Manufacture, Filing, Setting, Gumming, etc. Care and Use of Saws; Tables of Gauges; Capacities of Saw-Mills; List of Saw-Patents, and other valuable information. By ROBERT GRIMSHAW. Second and greatly enlarged edition, *with Supplement*, and 354 Illustrations. Quarto \$5.00

GRISWOLD.—Railroad Engineer's Pocket Companion for the Field :

Comprising Rules for Calculating Deflection Distances and Angles, Tangential Distances and Angles, and all Necessary Tables for Engineers; also the Art of Levelling from Preliminary Survey to the Construction of Railroads, intended Expressly for the Young Engineer, together with Numerous Valuable Rules and Examples. By W. GRISWOLD. 12mo., tucks \$1.75

GRUNER.—Studies of Blast Furnace Phenomena :

By M. L. GRUNER, President of the General Council of Mines of France, and lately Professor of Metallurgy at the Ecole des Mines. Translated, with the author's sanction, with an Appendix, by L. D. B. GORDON, F. R. S. E., F. G. S. 8vo. \$2.50

Hand-Book of Useful Tables for the Lumberman, Farmer and Mechanic :

Containing Accurate Tables of Logs Reduced to Inch Board Measure, Plank, Scantling and Timber Measure; Wages and Rent, by Week or Month; Capacity of Granaries, Bins and Cisterns; Land Measure, Interest Tables, with Directions for Finding the Interest on any sum at 4, 5, 6, 7 and 8 per cent., and many other Useful Tables. 32 mo., boards. 186 pages25

HASERICK.—The Secrets of the Art of Dyeing Wool, Cotton, and Linen,

Including Bleaching and Coloring Wool and Cotton Hosiery and Random Yarns. A Treatise based on Economy and Practice. By E. C. HASERICK. *Illustrated by 323 Dyed Patterns of the Yarns or Fabrics.* 8vo. \$7.50

HATS AND FELTING :

A Practical Treatise on their Manufacture. By a Practical Hatter. Illustrated by Drawings of Machinery, etc. 8vo. \$1.25

HOFFER.—A Practical Treatise on Caoutchouc and Gutta Percha,

Comprising the Properties of the Raw Materials, and the manner of Mixing and Working them; with the Fabrication of Vulcanized and Hard Rubbers, Caoutchouc and Gutta Percha Compositions, Water-proof Substances, Elastic Tissues, the Utilization of Waste, etc., etc. From the German of RAIMUND HOFFER. By W. T. BRANNT. Illustrated 12mo. \$2.50

HAUPT—RHAWN.—A Move for Better Roads :

Essays on Road-making and Maintenance and Road Laws, for which Prizes or Honorable Mention were Awarded through the University of Pennsylvania by a Committee of Citizens of Philadelphia, with a Synopsis of other Contributions and a Review by the Secretary, LEWIS M. HAUPT, A. M., C. E.; also an Introduction by WILLIAM H. RHAWN, Chairman of the Committee. 319 pages. 8vo. \$2.00

HUGHES.—American Miller and Millwright's Assistant :

By WILLIAM CARTER HUGHES. 12mo. \$1.50

HULME.—Worked Examination Questions in Plane Geometrical Drawing :

For the Use of Candidates for the Royal Military Academy, Woolwich; the Royal Military College, Sandhurst; the Indian Civil Engineering College, Cooper's Hill; Indian Public Works and Telegraph Departments; Royal Marine Light Infantry; the Oxford and Cambridge Local Examinations, etc. By F. EDWARD HULME, F. L. S., F. S. A., Art-Master Marlborough College. Illustrated by 300 examples. Small quarto \$2.50

JERVIS.—Railroad Property :

A Treatise on the Construction and Management of Railways; designed to afford useful knowledge, in the popular style, to the holders of this class of property; as well as Railway Managers, Officers, and Agents. By JOHN B. JERVIS, late Civil Engineer of the Hudson River Railroad, Croton Aqueduct, etc. 12mo., cloth \$2.00

KEENE.—A Hand-Book of Practical Gauging :

For the Use of Beginners, to which is added a Chapter on Distillation, describing the process in operation at the Custom-House for ascertaining the Strength of Wines. By JAMES B. KEENE, of H. M. Customs. 8vo. \$1.25

KELLEY.—Speeches, Addresses, and Letters on Industrial and Financial Questions :

By HON. WILLIAM D. KELLEY, M. C. 544 pages, 8vo. \$2.50

KELLOGG.—A New Monetary System :

The only means of Securing the respective Rights of Labor and Property, and of Protecting the Public from Financial Revulsions. By EDWARD KELLOGG. Revised from his work on "Labor and other Capital." With numerous additions from his manuscript. Edited by MARY KELLOGG PUTNAM. Fifth edition. To which is added a Biographical Sketch of the Author. One volume, 12mo. Paper cover \$1.00
Bound in cloth 1.50

KEMLO.—Watch-Repairer's Hand-Book :

Being a Complete Guide to the Young Beginner, in Taking Apart, Putting Together, and Thoroughly Cleaning the English Lever and other Foreign Watches, and all American Watches. By F. KEMLO, Practical Watchmaker. With Illustrations. 12mo. \$1.25

KENTISH.—A Treatise on a Box of Instruments,

And the Slide Rule; with the Theory of Trigonometry and Logarithms, including Practical Geometry, Surveying, Measuring of Timber, Cask and Malt Gauging, Heights, and Distances. By THOMAS KENTISH. In one volume. 12mo. . . . \$1.25

KERL.—The Assayer's Manual:

An Abridged Treatise on the Docimastic Examination of Ores, and Furnace and other Artificial Products. By BRUNO KERL, Professor in the Royal School of Mines. Translated from the German by WILLIAM T. BRANNT. Second American edition, edited with Extensive Additions by F. LYNWOOD GARRISON, Member of the American Institute of Mining Engineers, etc. Illustrated by 87 engravings. 8vo. . . . \$3.00

KICK.—Flour Manufacture.

A Treatise on Milling Science and Practice. By FREDERICK KICK, Imperial Regierungsrath, Professor of Mechanical Technology in the Imperial German Polytechnic Institute, Prague. Translated from the second enlarged and revised edition with supplement by H. H. P. POWLES, Assoc. Memb. Institution of Civil Engineers. Illustrated with 28 Plates, and 167 Wood-cuts. 367 pages. 8vo. . \$10.00

KINGZETT.—The History, Products, and Processes of the Alkali Trade:

Including the most Recent Improvements. By CHARLES THOMAS KINGZETT, Consulting Chemist. With 23 illustrations. 8vo. \$2.50

KIRK.—The Founding of Metals:

A Practical Treatise on the Melting of Iron, with a Description of the Founding of Alloys; also, of all the Metals and Mineral Substances used in the Art of Founding. Collected from original sources. By EDWARD KIRK, Practical Foundryman and Chemist. Illustrated. Third edition. 8vo. . . . \$2.50

LANDRIN.—A Treatise on Steel:

Comprising its Theory, Metallurgy, Properties, Practical Working, and Use. By M. H. C. LANDRIN, JR., Civil Engineer. Translated from the French, with Notes, by A. A. FESQUET, Chemist and Engineer. With an Appendix on the Bessemer and the Martin Processes for Manufacturing Steel, from the Report of Abram S. Hewitt, United States Commissioner to the Universal Exposition, Paris, 1867! 12mo. . . . \$3.00

LANGBEIN.—A Complete Treatise on the Electro-Deposition of Metals:

Translated from the German, with Additions, by WM. T. BRANNT. 125 illustrations. 8vo. . . . \$4.00

LARDNER.—The Steam-Engine:

For the Use of Beginners. Illustrated. 12mo. . . . 75

LEHNER.—The Manufacture of Ink:

Comprising the Raw Materials, and the Preparation of Writing, Copying and Hektograph Inks, Safety Inks, Ink Extracts and Powders, etc. Translated from the German of SIGMUND LEHNER, with additions by WILLIAM T. BRANNT. Illustrated. 12mo. \$2.00

LARKIN.—The Practical Brass and Iron Founder's Guide:

A Concise Treatise on Brass Founding, Moulding, the Metals and their Alloys, etc.; to which are added Recent Improvements in the Manufacture of Iron, Steel by the Bessemer Process, etc., etc. By JAMES LARKIN, late Conductor of the Brass Foundry Department in Reany, Neafie & Co.'s Penn Works, Philadelphia. New edition, revised, with extensive additions. 12mo. . . . \$2.50

LEROUX.—A Practical Treatise on the Manufacture of Worsteds and Carded Yarns:

Comprising Practical Mechanics, with Rules and Calculations applied to Spinning; Sorting, Cleaning, and Scouring Wools; the English and French Methods of Combing, Drawing, and Spinning Worsteds, and Manufacturing Carded Yarns. Translated from the French of CHARLES LEROUX, Mechanical Engineer and Superintendent of a Spinning-Mill, by HORATIO PAINE, M. D., and A. A. FESQUET, Chemist and Engineer. Illustrated by twelve large Plates. To which is added an Appendix, containing Extracts from the Reports of the International Jury, and of the Artisans selected by the Committee appointed by the Council of the Society of Arts, London, on Woolen and Worsted Machinery and Fabrics, as exhibited in the Paris Universal Exposition, 1867. 8vo. . . . \$5.00

LEFFEL.—The Construction of Mill-Dams:

Comprising also the Building of Race and Reservoir Embankments and Head-Gates, the Measurement of Streams, Gauging of Water Supply, etc. By JAMES LEFFEL & Co. Illustrated by 58 engravings. 8vo. . . . \$2.50

LESLIE.—Complete Cookery:

Directions for Cookery in its Various Branches. By MISS LESLIE. Sixtieth thousand. Thoroughly revised, with the addition of New Receipts. 12mo. . . . \$1.50

LE VAN.—The Steam Engine and the Indicator:

Their Origin and Progressive Development; including the Most Recent Examples of Steam and Gas Motors, together with the Indicator, its Principles, its Utility, and its Application. By WILLIAM BARNET LE VAN. Illustrated by 205 Engravings, chiefly of Indicator-Cards. 469 pp. 8vo. . . . \$4.00

LIEBER.—Assayer's Guide:

Or, Practical Directions to Assayers, Miners, and Smelters, for the Tests and Assays, by Heat and by Wet Processes, for the Ores of all the principal Metals, of Gold and Silver Coins and Alloys, and of Coal, etc. By OSCAR M. LIEBER. Revised. 283 pp. 12mo. \$1.50

Lockwood's Dictionary of Terms:

Used in the Practice of Mechanical Engineering, embracing those Current in the Drawing Office, Pattern Shop, Foundry, Fitting, Turning, Smith's and Boiler Shops, etc., etc., comprising upwards of Six Thousand Definitions. Edited by a Foreman Pattern Maker, author of "Pattern Making." 417 pp. 12mo. . . . \$3.00

LUKIN.—Amongst Machines:

Embracing Descriptions of the various Mechanical Appliances used in the Manufacture of Wood, Metal, and other Substances. 12mo.

\$1.75

LUKIN.—The Boy Engineers:

What They Did, and How They Did It. With 30 plates. 18mo.

\$1.75

LUKIN.—The Young Mechanic:

Practical Carpentry. Containing Directions for the Use of all kinds of Tools, and for Construction of Steam-Engines and Mechanical Models, including the Art of Turning in Wood and Metal. By JOHN LUKIN, Author of "The Lathe and Its Uses," etc. Illustrated. 12mo.

\$1.75

MAIN and BROWN.—Questions on Subjects Connected with the Marine Steam-Engine:

And Examination Papers; with Hints for their Solution. By THOMAS J. MAIN, Professor of Mathematics, Royal Naval College, and THOMAS BROWN, Chief Engineer, R. N. 12mo., cloth.

\$1.00

MAIN and BROWN.—The Indicator and Dynamometer:

With their Practical Applications to the Steam-Engine. By THOMAS J. MAIN, M. A. F. R., Ass't S. Professor Royal Naval College, Portsmouth, and THOMAS BROWN, Assoc. Inst. C. E., Chief Engineer R. N., attached to the R. N. College. Illustrated. 8vo.

\$1.00

MAIN and BROWN.—The Marine Steam-Engine.

By THOMAS J. MAIN, F. R. Ass't S. Mathematical Professor at the Royal Naval College, Portsmouth, and THOMAS BROWN, Assoc. Inst. C. E., Chief Engineer R. N. Attached to the Royal Naval College. With numerous illustrations. 8vo.

MAKINS.—A Manual of Metallurgy:

By GEORGE HOGARTH MAKINS. 100 engravings. Second edition rewritten and much enlarged. 12mo., 592 pages.

\$3.00

MARTIN.—Screw-Cutting Tables, for the Use of Mechanical Engineers:

Showing the Proper Arrangement of Wheels for Cutting the Threads of Screws of any Required Pitch; with a Table for Making the Universal Gas-Pipe Thread and Taps. By W. A. MARTIN, Engineer. 8vo.

50

MICHELL.—Mine Drainage:

Being a Complete and Practical Treatise on Direct-Acting Underground Steam Pumping Machinery. With a Description of a large number of the best known Engines, their General Utility and the Special Sphere of their Action, the Mode of their Application, and their Merits compared with other Pumping Machinery. By STEPHEN MICHELL. Illustrated by 137 engravings. 8vo., 277 pages.

\$6.00

MOLESWORTH.—Pocket-Book of Useful Formulæ and Memoranda for Civil and Mechanical Engineers.

By GUILFORD L. MOLESWORTH, Member of the Institution of Civil Engineers, Chief Resident Engineer of the Ceylon Railway. Full-bound in Pocket-book form.

\$1.00

MOORE.—The Universal Assistant and the Complete Mechanic:

Containing over one million Industrial Facts, Calculations, Receipts, Processes, Trades Secrets, Rules, Business Forms, Legal Items, Etc., in every occupation, from the Household to the Manufactory. By R. MOORE. Illustrated by 500 Engravings. 12mo. \$2.50

MORRIS.—Easy Rules for the Measurement of Earthworks:

By means of the Prismoidal Formula. Illustrated with Numerous Wood-Cuts, Problems, and Examples, and concluded by an Extensive Table for finding the Solidity in cubic yards from Mean Areas. The whole being adapted for convenient use by Engineers, Surveyors, Contractors, and others needing Correct Measurements of Earthwork. By ELWOOD MORRIS, C. E. 8vo. \$1.50

MORTON.—The System of Calculating Diameter, Circumference, Area, and Squaring the Circle:

Together with Interest and Miscellaneous Tables, and other information. By JAMES MORTON. Second Edition, enlarged, with the Metric System. 12mo. 50

NAPIER.—Manual of Electro-Metallurgy:

Including the Application of the Art to Manufacturing Processes. By JAMES NAPIER. Fourth American, from the Fourth London edition, revised and enlarged. Illustrated by engravings. 8vo.

NAPIER.—A System of Chemistry Applied to Dyeing.

By JAMES NAPIER, F. C. S. A New and Thoroughly Revised Edition. Completely brought up to the present state of the Science, including the Chemistry of Coal Tar Colors, by A. A. FESQUET, Chemist and Engineer. With an Appendix on Dyeing and Calico Printing, as shown at the Universal Exposition, Paris, 1867. Illustrated. 8vo. 422 pages \$3.50

NEVILLE.—Hydraulic Tables, Coefficients, and Formulæ, for finding the Discharge of Water from Orifices, Notches, Weirs, Pipes, and Rivers:

Third Edition, with Additions, consisting of New Formulæ for the Discharge from Tidal and Flood Sluices and Siphons; general information on Rainfall, Catchment-Basins, Drainage, Sewerage, Water Supply for Towns and Mill Power. By JOHN NEVILLE, C. E. M. R. I. A.; Fellow of the Royal Geological Society of Ireland. Thick 12mo. \$5.50

NEWBERY.—Gleanings from Ornamental Art of every style:

Drawn from Examples in the British, South Kensington, Indian, Crystal Palace, and other Museums, the Exhibitions of 1851 and 1862, and the best English and Foreign works. In a series of 100 exquisitely drawn Plates, containing many hundred examples. By ROBERT NEWBERY. 4to. \$12.50

NICHOLLS.—The Theoretical and Practical Boiler-Maker and Engineer's Reference Book:

Containing a variety of Useful Information for Employers of Labor Foremen and Working Boiler-Makers, Iron, Copper, and Tinsmiths

- Draughtsmen, Engineers, the General Steam-using Public, and for the Use of Science Schools and Classes.** By SAMUEL NICHOLLS. Illustrated by sixteen plates, 12mo. \$2.50
- NICHOLSON.—A Manual of the Art of Bookbinding:**
Containing full instructions in the different Branches of Forwarding, Gilding, and Finishing. Also, the Art of Marbling Book-edges and Paper. By JAMES B. NICHOLSON. Illustrated, 12mo., cloth \$2.25
- NICOLLS.—The Railway Builder:**
A Hand-Book for Estimating the Probable Cost of American Railway Construction and Equipment. By WILLIAM J. NICOLLS, Civil Engineer. Illustrated, full bound, pocket-book form \$2.00
- NORMANDY.—The Commercial Handbook of Chemical Analysis:**
Or Practical Instructions for the Determination of the Intrinsic or Commercial Value of Substances used in Manufactures, in Trades, and in the Arts. By A. NORMANDY. New Edition, Enlarged, and to a great extent rewritten. By HENRY M. NOAD, Ph.D., F.R.S., thick 12mo. \$5.00
- NORRIS.—A Handbook for Locomotive Engineers and Machinists:**
Comprising the Proportions and Calculations for Constructing Locomotives; Manner of Setting Valves; Tables of Squares, Cubes, Areas, etc., etc. By SEPTIMUS NORRIS, M. E. New edition. Illustrated, 12mo. \$1.50
- NYSTROM.—A New Treatise on Elements of Mechanics:**
Establishing Strict Precision in the Meaning of Dynamical Terms: accompanied with an Appendix on Duodenal Arithmetic and Metrology. By JOHN W. NYSTROM, C. E. Illustrated. 8vo. \$2.00
- NYSTROM.—On Technological Education and the Construction of Ships and Screw Propellers:**
For Naval and Marine Engineers. By JOHN W. NYSTROM, late Acting Chief Engineer, U. S. N. Second edition, revised, with additional matter. Illustrated by seven engravings. 12mo. \$1.50
- O'NEILL.—A Dictionary of Dyeing and Calico Printing:**
Containing a brief account of all the Substances and Processes in use in the Art of Dyeing and Printing Textile Fabrics; with Practical Receipts and Scientific Information. By CHARLES O'NEILL, Analytical Chemist. To which is added an Essay on Coal Tar Colors and their application to Dyeing and Calico Printing. By A. A. FESQUET, Chemist and Engineer. With an appendix on Dyeing and Calico Printing, as shown at the Universal Exposition, Paris, 1867. 8vo. 491 pages \$3.50
- ORTON.—Underground Treasures:**
How and Where to Find Them. A Key for the Ready Determination of all the Useful Minerals within the United States. By JAMES ORTON, A.M., Late Professor of Natural History in Vassar College, N. Y.; Cor. Mem. of the Academy of Natural Sciences, Philadelphia, and of the Lyceum of Natural History, New York; author of the "Andes and the Amazon," etc. A New Edition, with Additions. Illustrated \$1.50

OSBORN.—The Prospector's Field Book and Guide:

In the Search for and the Easy Determination of Ores and Other Useful Minerals. By Prof. H. S. OSBORN, LL. D., Author of "The Metallurgy of Iron and Steel;" "A Practical Manual of Minerals, Mines, and Mining." Illustrated by 44 Engravings. 12mo. \$1.50

OSBORN.—A Practical Manual of Minerals, Mines and Mining:

Comprising the Physical Properties, Geologic Positions, Local Occurrence and Associations of the Useful Minerals; their Methods of Chemical Analysis and Assay: together with Various Systems of Excavating and Timbering, Brick and Masonry Work, during Driving, Lining, Bracing and other Operations, etc. By Prof. H. S. OSBORN, LL. D., Author of the "Metallurgy of Iron and Steel." Illustrated by 171 engravings from original drawings. 8vo. \$4.50

OVERMAN.—The Manufacture of Steel:

Containing the Practice and Principles of Working and Making Steel. A Handbook for Blacksmiths and Workers in Steel and Iron, Wagon Makers, Die Sinkers, Cutlers, and Manufacturers of Files and Hardware, of Steel and Iron, and for Men of Science and Art. By FREDERICK OVERMAN, Mining Engineer, Author of the "Manufacture of Iron," etc. A new, enlarged, and revised Edition. By A. A. FESQUET, Chemist and Engineer. 12mo. \$1.50

OVERMAN.—The Moulder's and Founder's Pocket Guide:

A Treatise on Moulding and Founding in Green-sand, Dry-sand, Loam, and Cement; the Moulding of Machine Frames, Mill-gear, Hollowware, Ornaments, Trinkets, Bells, and Statues; Description of Moulds for Iron, Bronze, Brass, and other Metals; Plaster of Paris, Sulphur, Wax, etc.; the Construction of Melting Furnaces, the Melting and Founding of Metals; the Composition of Alloys and their Nature, etc., etc. By FREDERICK OVERMAN, M. E. A new Edition, to which is added a Supplement on Statuary and Ornamental Moulding, Ordnance, Malleable Iron Castings, etc. By A. A. FESQUET, Chemist and Engineer. Illustrated by 44 engravings. 12mo. \$2.00

PAINTER, GILDER, AND VARNISHER'S COMPANION:

Containing Rules and Regulations in everything relating to the Arts of Painting, Gilding, Varnishing, Glass-Staining, Graining, Marbling, Sign-Writing, Gilding on Glass, and Coach Painting and Varnishing; Tests for the Detection of Adulterations in Oils, Colors, etc.; and a Statement of the Diseases to which Painters are peculiarly liable, with the Simplest and Best Remedies. Sixteenth Edition. Revised, with an Appendix. Containing Colors and Coloring—Theoretical and Practical. Comprising descriptions of a great variety of Additional Pigments, their Qualities and Uses, to which are added, Dryers, and Modes and Operations of Painting, etc. Together with Chevreul's Principles of Harmony and Contrast of Colors. 12mo. Cloth \$1.50

PALLETT.—The Miller's, Millwright's, and Engineer's Guide.

By HENRY PALLETT. Illustrated. 12mo. \$2.00

PERCY.—The Manufacture of Russian Sheet-Iron.

By JOHN PERCY, M. D., F. R. S., Lecturer on Metallurgy at the Royal School of Mines, and to The Advance Class of Artillery Officers at the Royal Artillery Institution, Woolwich; Author of "Metallurgy." With Illustrations. 8vo., paper . . . 50 cts.

PERKINS.—Gas and Ventilation :

Practical Treatise on Gas and Ventilation. With Special Relation to Illuminating, Heating, and Cooking by Gas. Including Scientific Helps to Engineer-students and others. With Illustrated Diagrams. By E. E. PERKINS. 12mo., cloth . . . \$1.25

PERKINS AND STOWE.—A New Guide to the Sheet-iron and Boiler Plate Roller :

Containing a Series of Tables showing the Weight of Slabs and Piles to Produce Boiler Plates, and of the Weight of Piles and the Sizes of Bars to produce Sheet-iron; the Thickness of the Bar Gauge in decimals; the Weight per foot, and the Thickness on the Bar or Wire Gauge of the fractional parts of an inch; the Weight per sheet, and the Thickness on the Wire Gauge of Sheet-iron of various dimensions to weigh 112 lbs. per bundle; and the conversion of Short Weight into Long Weight, and Long Weight into Short. Estimated and collected by G. H. PERKINS and J. G. STOWE. \$2.50

POWELL—CHANCE—HARRIS.—The Principles of Glass Making.

By HARRY J. POWELL, B. A. Together with Treatises on Crown and Sheet Glass; by HENRY CHANCE, M. A. And Plate Glass, by H. G. HARRIS, Asso. M. Inst. C. E. Illustrated 18mo. . . \$1.50

PROCTOR.—A Pocket-Book of Useful Tables and Formulæ for Marine Engineers :

By FRANK PROCTOR. Second Edition, Revised and Enlarged. Full-bound pocket-book form . . . \$1.50

REGNAULT.—Elements of Chemistry :

By M. V. REGNAULT. Translated from the French by T. FORREST BETTON, M. D., and edited, with Notes, by JAMES C. BOOTH, Melter and Refiner U. S. Mint, and WILLIAM L. FABER, Metallurgist and Mining Engineer. Illustrated by nearly 700 wood-engravings. Comprising nearly 1,500 pages. In two volumes, 8vo., cloth . . . \$7.50

RICHARDS.—Aluminium :

Its History, Occurrence, Properties, Metallurgy and Applications, including its Alloys. By JOSEPH W. RICHARDS, A. C., Chemist and Practical Metallurgist, Member of the Deutsche Chemische Gesellschaft. Illustrated . . . \$5.00

RIFFAULT, VERGNAUD, and TOUSSAINT.—A Practical Treatise on the Manufacture of Colors for Painting :

Comprising the Origin, Definition, and Classification of Colors; the Treatment of the Raw Materials; the best Formulæ and the Newest Processes for the Preparation of every description of Pigment, and the Necessary Apparatus and Directions for its Use; Dryers; the Testing. Application, and Qualities of Paints, etc., etc. By MM. RIFFAULT, VERGNAUD, and TOUSSAINT. Revised and Edited by M.

- F. MALEPEYRE. Translated from the French, by A. A. FESQUET, Chemist and Engineer. Illustrated by Eighty engravings. In one vol., 8vo., 659 pages \$7.50
- ROPER.—A Catechism of High-Pressure, or Non-Condensing Steam-Engines :**
Including the Modelling, Constructing, and Management of Steam-Engines and Steam Boilers. With valuable illustrations. By STEPHEN ROPER, Engineer. Sixteenth edition, revised and enlarged. 18mo., tucks, gilt edge \$2.00
- ROPER.—Engineer's Handy-Book :**
Containing a full Explanation of the Steam-Engine Indicator, and its Use and Advantages to Engineers and Steam Users. With Formulæ for Estimating the Power of all Classes of Steam-Engines; also, Facts, Figures, Questions, and Tables for Engineers who wish to qualify themselves for the United States Navy, the Revenue Service, the Mercantile Marine, or to take charge of the Better Class of Stationary Steam-Engines. Sixth edition. 16mo., 690 pages, tucks, gilt edge \$3.50
- ROPER.—Hand-Book of Land and Marine Engines :**
Including the Modelling, Construction, Running, and Management of Land and Marine Engines and Boilers. With illustrations. By STEPHEN ROPER, Engineer. Sixth edition. 12mo., tucks, gilt edge. \$3.50
- ROPER.—Hand-Book of the Locomotive :**
Including the Construction of Engines and Boilers, and the Construction, Management, and Running of Locomotives. By STEPHEN ROPER. Eleventh edition. 18mo., tucks, gilt edge \$2.50
- ROPER.—Hand-Book of Modern Steam Fire-Engines.**
With illustrations. By STEPHEN ROPER, Engineer. Fourth edition. 12mo., tucks, gilt edge \$3.50
- ROPER.—Questions and Answers for Engineers.**
This little book contains all the Questions that Engineers will be asked when undergoing an Examination for the purpose of procuring Licenses, and they are so plain that any Engineer or Fireman of ordinary intelligence may commit them to memory in a short time. By STEPHEN ROPER, Engineer. Third edition \$3.00
- ROPER.—Use and Abuse of the Steam Boiler.**
By STEPHEN ROPER, Engineer. Eighth edition, with illustrations. 18mo., tucks, gilt edge \$2.00
- ROSE.—The Complete Practical Machinist :**
Embracing Lathe Work, Vise Work, Drills and Drilling, Taps and Dies, Hardening and Tempering, the Making and Use of Tools, Tool Grinding, Marking out Work, etc. By JOSHUA ROSE. Illustrated by 356 engravings. Thirteenth edition, thoroughly revised and in great part rewritten. In one vol., 12mo., 439 pages \$2.50
- ROSE.—Mechanical Drawing Self-Taught :**
Comprising Instructions in the Selection and Preparation of Drawing Instruments, Elementary Instruction in Practical Mechanical Draw

- ing, together with Examples in Simple Geometry and Elementary Mechanism, including Screw Threads, Gear Wheels, Mechanical Motions, Engines and Boilers. By JOSHUA ROSE, M. E. Illustrated by 330 engravings. 8vo, 313 pages . . . \$4.00
- ROSE.—The Slide-Valve Practically Explained :**
Embracing simple and complete Practical Demonstrations of the operation of each element in a Slide-valve Movement, and illustrating the effects of Variations in their Proportions by examples carefully selected from the most recent and successful practice. By JOSHUA ROSE, M. E. Illustrated by 35 engravings . . . \$1.00
- ROSS.—The Blowpipe in Chemistry, Mineralogy and Geology :**
Containing all Known Methods of Anhydrous Analysis, many Working Examples, and Instructions for Making Apparatus. By LIEUT.-COLONEL W. A. ROSS, R. A., F. G. S. With 120 Illustrations. 12mo. \$2.00
- SHAW.—Civil Architecture :**
Being a Complete Theoretical and Practical System of Building, containing the Fundamental Principles of the Art. By EDWARD SHAW, Architect. To which is added a Treatise on Gothic Architecture, etc. By THOMAS W. SILLOWAY and GEORGE M. HARDING, Architects. The whole illustrated by 102 quarto plates finely engraved on copper. Eleventh edition. 4to. \$10.00
- SHUNK.—A Practical Treatise on Railway Curves and Location for Young Engineers.**
By W. F. SHUNK, C. E. 12mo. Full bound pocket-book form \$2.00
- SLATER.—The Manual of Colors and Dye Wares.**
By J. W. SLATER. 12mo. \$3.00
- SLOAN.—American Houses :**
A variety of Original Designs for Rural Buildings. Illustrated by 26 colored engravings, with descriptive references. By SAMUEL SLOAN, Architect. 8vo. \$1.50
- SLOAN.—Homestead Architecture :**
Containing Forty Designs for Villas, Cottages, and Farm-houses, with Essays on Style, Construction, Landscape Gardening, Furniture, etc., etc. Illustrated by upwards of 200 engravings. By SAMUEL SLOAN, Architect. 8vo. \$3.50
- SLOANE.—Home Experiments in Science.**
By T. O'CONNOR SLOANE, E. M., A. M., F. R. D. Illustrated by 91 engravings. 12mo. \$1.50
- SMEATON.—Builder's Pocket-Companion :**
Containing the Elements of Building, Surveying, and Architecture; with Practical Rules and Instructions connected with the subject. By A. C. SMEATON, Civil Engineer, etc. 12mo. . . . \$1.50
- SMITH.—A Manual of Political Economy.**
By E. PESHINE SMITH. A New Edition, to which is added a full Index. 12mo. \$1 25

- SMITH.—Parks and Pleasure-Grounds :**
 Or Practical Notes on Country Residences, Villas, Public Parks, and Gardens. By CHARLES H. J. SMITH, Landscape Gardener and Garden Architect, etc., etc. 12mo. \$2.00
- SMITH.—The Dyer's Instructor :**
 Comprising Practical Instructions in the Art of Dyeing Silk, Cotton, Wool, and Worsted, and Woolen Goods; containing nearly 800 Receipts. To which is added a Treatise on the Art of Padding; and the Printing of Silk Warps, Skeins, and Handkerchiefs, and the various Mordants and Colors for the different styles of such work, By DAVID SMITH, Pattern Dyer. 12mo. \$2.00
- SMYTH.—A Rudimentary Treatise on Coal and Coal-Mining.**
 By WARRINGTON W. SMYTH, M. A., F. R. G., President R. G. S. of Cornwall. Fifth edition, revised and corrected. With numerous illustrations. 12mo. \$1.75
- SNIVELY.—Tables for Systematic Qualitative Chemical Analysis.**
 By JOHN H. SNIVELY, Phr. D. 8vo. \$1.00
- SNIVELY.—The Elements of Systematic Qualitative Chemical Analysis :**
 A Hand-book for Beginners. By JOHN H. SNIVELY, Phr. D. 16mo. \$2.00
- STOKES.—The Cabinet-Maker and Upholsterer's Companion :**
 Comprising the Art of Drawing, as applicable to Cabinet Work; Veneering, Inlaying, and Buhl-Work; the Art of Dyeing and Staining Wood, Ivory, Bone, Tortoise-Shell, etc. Directions for Lacker-ing, Japanning, and Varnishing; to make French Polish, Glues, Cements, and Compositions; with numerous Receipts, useful to work men generally. By STOKES. Illustrated. A New Edition, with an Appendix upon French Polishing, Staining, Imitating, Varnishing, etc., etc. 12mo \$1.25
- STRENGTH AND OTHER PROPERTIES OF METALS :**
 Reports of Experiments on the Strength and other Properties of Metals for Cannon. With a Description of the Machines for Testing Metals, and of the Classification of Cannon in service. By Officers of the Ordnance Department, U. S. Army. By authority of the Secretary of War. Illustrated by 25 large steel plates. Quarto . . . \$10.00
- SULLIVAN.—Protection to Native Industry.**
 By Sir EDWARD SULLIVAN, Baronet, author of "Ten Chapters on Social Reforms." 8vo. \$1.00
- SULZ.—A Treatise on Beverages :**
 Or the Complete Practical Bottler. Full instructions for Laboratory Work, with Original Practical Recipes for all kinds of Carbonated Drinks, Mineral Waters, Flavorings, Extracts, Syrups, etc. By CHAS HERMAN SULZ, Technical Chemist and Practical Bottler Illustrated by 428 Engravings. 818 pp. 8vo. \$10.00

- SYME.—Outlines of an Industrial Science.**
By DAVID SYME. 12mo. \$2.00
- TABLES SHOWING THE WEIGHT OF ROUND, SQUARE, AND FLAT BAR IRON, STEEL, ETC.,**
By Measurement. Cloth 63
- TAYLOR.—Statistics of Coal:**
Including Mineral Bituminous Substances employed in Arts and Manufactures; with their Geographical, Geological, and Commercial Distribution and Amount of Production and Consumption on the American Continent. With Incidental Statistics of the Iron Manufacture. By R. C. TAYLOR. Second edition, revised by S. S. HALDEMAN. Illustrated by five Maps and many wood engravings. 8vo., cloth \$10.00
- TEMPLETON.—The Practical Examinator on Steam and the Steam-Engine:**
With Instructive References relative thereto, arranged for the Use of Engineers, Students, and others. By WILLIAM TEMPLETON, Engineer. 12mo. \$1.00
- THAUSING.—The Theory and Practice of the Preparation of Malt and the Fabrication of Beer:**
With especial reference to the Vienna Process of Brewing. Elaborated from personal experience by JULIUS E. THAUSING, Professor at the School for Brewers, and at the Agricultural Institute, Mödling, near Vienna. Translated from the German by WILLIAM T. BRANNT. Thoroughly and elaborately edited, with much American matter, and according to the latest and most Scientific Practice, by A. SCHWARZ and DR. A. H. BAUER. Illustrated by 140 Engravings. 8vo., 815 pages \$10.00
- THOMAS.—The Modern Practice of Photography:**
By R. W. THOMAS, F. C. S. 8vo. 75
- THOMPSON.—Political Economy. With Especial Reference to the Industrial History of Nations:**
By ROBERT E. THOMPSON, M. A., Professor of Social Science in the University of Pennsylvania. 12mo. \$1.50
- THOMSON.—Freight Charges Calculator:**
By ANDREW THOMSON, Freight Agent. 24mo. \$1.25
- TURNER'S (THE) COMPANION:**
Containing Instructions in Concentric, Elliptic, and Eccentric Turning; also various Plates of Chucks, Tools, and Instruments; and Directions for using the Eccentric Cutter, Drill, Vertical Cutter, and Circular Rest; with Patterns and Instructions for working them. 12mo. \$1.25
- TURNING: Specimens of Fancy Turning Executed on the Hand or Foot-Lathe:**
With Geometric, Oval, and Eccentric Chucks, and Elliptical Cutting Frame. By an Amateur. Illustrated by 30 exquisite Photographs. 4to. \$3.00

VAILE.—Galvanized-Iron Cornice-Worker's Manual :

Containing Instructions in Laying out the Different Mitres, and Making Patterns for all kinds of Plain and Circular Work. Also, Tables of Weights, Areas and Circumferences of Circles, and other Matter calculated to Benefit the Trade. By CHARLES A. VAILE. Illustrated by twenty-one plates. 4to. \$5.00

VILLE.—On Artificial Manures :

Their Chemical Selection and Scientific Application to Agriculture. A series of Lectures given at the Experimental Farm at Vincennes, during 1867 and 1874-75. By M. GEORGES VILLE. Translated and Edited by WILLIAM CROOKES, F. R. S. Illustrated by thirty-one engravings. 8vo., 450 pages \$6.00

VILLE.—The School of Chemical Manures :

Or, Elementary Principles in the Use of Fertilizing Agents. From the French of M. GEO. VILLE, by A. A. FESQUET, Chemist and Engineer. With Illustrations. 12mo. \$1.25

VOGDES.—The Architect's and Builder's Pocket-Companion and Price-Book :

Consisting of a Short but Comprehensive Epitome of Decimals, Duodecimals, Geometry and Mensuration; with Tables of United States Measures, Sizes, Weights, Strengths, etc., of Iron, Wood, Stone, Brick, Cement and Concretes, Quantities of Materials in given Sizes and Dimensions of Wood, Brick and Stone; and full and complete Bills of Prices for Carpenter's Work and Painting; also, Rules for Computing and Valuing Brick and Brick Work, Stone Work, Painting, Plastering, with a Vocabulary of Technical Terms, etc. By FRANK W. VOGDES, Architect, Indianapolis, Ind. Enlarged, revised, and corrected. In one volume, 368 pages, full-bound, pocket-book form, gilt edges \$2.00
Cloth 1.50

VAN CLEVE.—The English and American Mechanic :

Comprising a Collection of Over Three Thousand Receipts, Rules, and Tables, designed for the Use of every Mechanic and Manufacturer. By B. FRANK VAN CLEVE. Illustrated. 500 pp. 12mo. \$2.00

WAHNSCHAFFE.—A Guide to the Scientific Examination of Soils :

Comprising Select Methods of Mechanical and Chemical Analysis and Physical Investigation. Translated from the German of Dr. F. WAHNSCHAFFE. With additions by WILLIAM T. BRANNT. Illustrated by 25 engravings. 12mo. 177 pages \$1.50

WALL.—Practical Graining :

With Descriptions of Colors Employed and Tools Used. Illustrated by 47 Colored Plates, Representing the Various Woods Used in Interior Finishing. By WILLIAM E. WALL. 8vo. \$2.50

WALTON.—Coal-Mining Described and Illustrated :

By THOMAS H. WALTON, Mining Engineer. Illustrated by 24 large and elaborate Plates, after Actual Workings and Apparatus. \$5.00

WARE.—The Sugar Beet.

Including a History of the Beet Sugar Industry in Europe, Varieties of the Sugar Beet, Examination, Soils, Tillage, Seeds and Sowing, Yield and Cost of Cultivation, Harvesting, Transportation, Conservation, Feeding Qualities of the Beet and of the Pulp, etc. By LEWIS S. WARE, C. E., M. E. Illustrated by ninety engravings. 8vo.

\$4.00

WARN.—The Sheet-Metal Worker's Instructor:

For Zinc, Sheet-Iron, Copper, and Tin-Plate Workers, etc. Containing a selection of Geometrical Problems; also, Practical and Simple Rules for Describing the various Patterns required in the different branches of the above Trades. By REUBEN H. WARN, Practical Tin-Plate Worker. To which is added an Appendix, containing Instructions for Boiler-Making, Mensuration of Surfaces and Solids, Rules for Calculating the Weights of different Figures of Iron and Steel, Tables of the Weights of Iron, Steel, etc. Illustrated by thirty-two Plates and thirty-seven Wood Engravings. 8vo.

\$3.00

WARNER.—New Theorems, Tables, and Diagrams, for the Computation of Earth-work:

Designed for the use of Engineers in Preliminary and Final Estimates, of Students in Engineering, and of Contractors and other non-professional Computers. In two parts, with an Appendix. Part I. A Practical Treatise; Part II. A Theoretical Treatise, and the Appendix. Containing Notes to the Rules and Examples of Part I.; Explanations of the Construction of Scales, Tables, and Diagrams, and a Treatise upon Equivalent Square Bases and Equivalent Level Heights. The whole illustrated by numerous original engravings, comprising explanatory cuts for Definitions and Problems, Stereometric Scales and Diagrams, and a series of Lithographic Drawings from Models; Showing all the Combinations of Solid Forms which occur in Railroad Excavations and Embankments. By JOHN WARNER, A. M., Mining and Mechanical Engineer. Illustrated by 14 Plates. A new, revised and improved edition. 8vo.

\$4.00

WATSON.—A Manual of the Hand-Lathe:

Comprising Concise Directions for Working Metals of all kinds, Ivory, Bone and Precious Woods; Dyeing, Coloring, and French Polishing; Inlaying by Veneers, and various methods practised to produce Elaborate work with Dispatch, and at Small Expense. By EGBERT P. WATSON, Author of "The Modern Practice of American Machinists and Engineers." Illustrated by 78 engravings.

\$1.50

WATSON.—The Modern Practice of American Machinists and Engineers:

Including the Construction, Application, and Use of Drills, Lathe Tools, Cutters for Boring Cylinders, and Hollow-work generally, with the most Economical Speed for the same; the Results verified by Actual Practice at the Lathe, the Vise, and on the Floor. Together

- with Workshop Management, Economy of Manufacture, the Steam Engine, Boilers, Gears, Belting, etc., etc. By **EGBERT P. WATSON**. Illustrated by eighty-six engravings. 12mo. \$2.50
- WATSON.**—The Theory and Practice of the Art of Weaving by Hand and Power
With Calculations and Tables for the Use of those connected with the Trade. By **JOHN WATSON**, Manufacturer and Practical Machine-Maker. Illustrated by large Drawings of the best Power Looms. 8vo. \$6.00
- WATT.**—The Art of Soap Making:
A Practical Hand-book of the Manufacture of Hard and Soft Soaps, Toilet Soaps, etc., including many New Processes, and a Chapter on the Recovery of Glycerine from Waste Leys. By **ALEXANDER WATT**. Ill. 12mo. \$3.00
- WEATHERLY.**—Treatise on the Art of Boiling Sugar, Crystallizing, Lozenge-making, Comfits, Gum Goods,
And other processes for Confectionery, etc., in which are explained, in an easy and familiar manner, the various Methods of Manufacturing every Description of Raw and Refined Sugar Goods, as sold by Confectioners and others. 12mo. \$1.50
- WIGHTWICK.**—Hints to Young Architects:
Comprising Advice to those who, while yet at school, are destined to the Profession; to such as, having passed their pupilage, are about to travel; and to those who, having completed their education, are about to practise. Together with a Model Specification involving a great variety of instructive and suggestive matter. By **GEORGE WIGHTWICK**, Architect. A new edition, revised and considerably enlarged; comprising Treatises on the Principles of Construction and Design. By **G. HUSKISSON GUILLAUME**, Architect. Numerous illustrations. One vol. 12mo. \$2.00
- WILL.**—Tables of Qualitative Chemical Analysis.
With an Introductory Chapter on the Course of Analysis. By Professor **HEINRICH WILL**, of Giessen, Germany. Third American, from the eleventh German edition. Edited by **CHARLES F. HIMES**, Ph. D., Professor of Natural Science, Dickinson College, Carlisle, Pa. 8vo. \$1.50
- WILLIAMS.**—On Heat and Steam:
Embracing New Views of Vaporization, Condensation, and Expansion. By **CHARLES WYE WILLIAMS**, A. I. C. E. Illustrated 8vo. \$3.50
- WILSON.**—A Treatise on Steam Boilers:
Their Strength, Construction, and Economical Working. By **ROBERT WILSON**. Illustrated 12mo. \$2.50
- WILSON.**—First Principles of Political Economy:
With Reference to Statesmanship and the Progress of Civilization. By Professor **W. D. WILSON**, of the Cornell University. A new and revised edition. 12mo. \$1.50

WOHLER.—A Hand-Book of Mineral Analysis :

By F. WÖHLER, Professor of Chemistry in the University of Göttingen. Edited by HENRY B. NASON, Professor of Chemistry in the Rensselaer Polytechnic Institute, Troy, New York. Illustrated.
12mo. \$3.00

WORSSAM.—On Mechanical Saws :

From the Transactions of the Society of Engineers, 1869. By S. W. WORSSAM, JR. Illustrated by eighteen large plates. 8vo. \$2.50

RECENT ADDITIONS.
ANDERSON.—The Prospector's Hand-Book :

A Guide for the Prospector and Traveler in Search of Metal Bearing or other Valuable Minerals. By J. W. ANDERSON. 52 Illustrations.
12mo. \$1.50

BRANNT.—The Practical Scourer and Garment Dyer :

Comprising Dry or Chemical Cleaning; the Art of Removing Stains; Fine Washing; Bleaching and Dyeing of Straw Hats, Gloves, and Feathers of all kinds; Dyeing of Worn Clothes of all fabrics, including Mixed Goods, by One Dip; and the Manufacture of Soaps and Fluids for Cleansing Purposes. Edited by WILLIAM T. BRANNT, Editor of "The Techno-Chemical Receipt Book." Illustrated.
203 pages. 12mo. \$2.00

BRANNT.—The Metallic Alloys :

A Practical Guide for the Manufacture of all kinds of Alloys, Amalgams and Solders used by Metal Workers, especially by Bell Founders, Bronze Workers, Tinsmiths, Gold and Silver Workers, Dentists, etc., etc., as well as their Chemical and Physical Properties. Edited chiefly from the German of A. Krupp and Andreas Wildberger, with additions by WM. T. BRANNT. Illustrated. 12mo. \$3.00

BRANNT.—A Practical Treatise on the Manufacture of Vinegar and Acetates, Cider, and Fruit-Wines :

Preservation of Fruits and Vegetables by Canning and Evaporation; Preparation of Fruit-Butters, Jellies, Marmalades, Catchups, Pickles, Mu-tards, etc. Edited from various sources. By WILLIAM T. BRANNT. Illustrated by 79 Engravings. 479 pp. 8vo. \$5.00

BRANNT.—The Metal Worker's Handy-Book of Receipts and Processes :

Being a Collection of Chemical Formulas and Practical Manipulations for the working of all Metals; including the Decoration and Beautifying of Articles Manufactured therefrom, as well as their Preservation. Edited from various sources. By WILLIAM T. BRANNT. Illustrated. 12mo. \$2.50

DEITE.—A Practical Treatise on the Manufacture of Perfumery:

Comprising directions for making all kinds of Perfumes, Sachet Powders, Fumigating Materials, Dentifrices, Cosmetics, etc., with a full account of the Volatile Oils, Balsams, Resins, and other Natural and Artificial Perfume-substances, including the Manufacture of Fruit Ethers, and tests of their purity. By Dr. C. DEITE, assisted by L. BORCHERT, F. EICHBAUM, E. KUGLER, H. TOEFFNER, and other experts. From the German, by WM. T. BRANNT. 28 Engravings. 358 pages. 8vo. \$3.00

EDWARDS.—American Marine Engineer, Theoretical and Practical:

With Examples of the latest and most approved American Practice. By EMORY EDWARDS. 85 illustrations. 12mo. . . . \$2.50

EDWARDS.—600 Examination Questions and Answers:

For Engineers and Firemen (Land and Marine) who desire to obtain a United States Government or State License. Pocket-book form, gilt edge \$1.50

POSSELT.—Technology of Textile Design:

Being a Practical Treatise on the Construction and Application of Weaves for all Textile Fabrics, with minute reference to the latest Inventions for Weaving. Containing also an Appendix, showing the Analysis and giving the Calculations necessary for the Manufacture of the various Textile Fabrics. By E. A. POSSELT, Head Master Textile Department, Pennsylvania Museum and School of Industrial Art, Philadelphia, with over 1000 illustrations. 292 pages. 4to. \$5.00

POSSELT.—The Jacquard Machine Analysed and Explained:

With an Appendix on the Preparation of Jacquard Cards, and Practical Hints to Learners of Jacquard Designing. By E. A. POSSELT. With 230 illustrations and numerous diagrams. 127 pp. 4to. \$3.00

POSSELT.—The Structure of Fibres, Yarns and Fabrics:

Being a Practical Treatise for the Use of all Persons Employed in the Manufacture of Textile Fabrics, containing a Description of the Growth and Manipulation of Cotton, Wool, Worsted, Silk, Flax, Jute, Ramie, China Grass and Hemp, and Dealing with all Manufacturers' Calculations for Every Class of Material, also Giving Minute Details for the Structure of all kinds of Textile Fabrics, and an Appendix of Arithmetic, specially adapted for Textile Purposes. By E. A. POSSELT. Over 400 Illustrations. quarto. . . \$10.00

RICH.—Artistic Horse-Shoeing:

A Practical and Scientific Treatise, giving Improved Methods of Shoeing, with Special Directions for Shaping Shoes to Cure Different Diseases of the Foot, and for the Correction of Faulty Action in Trotters. By GEORGE E. RICH. 62 Illustrations. 153 pages. 12mo. \$1.00

RICHARDSON.—Practical Blacksmithing :

A Collection of Articles Contributed at Different Times by Skilled Workmen to the columns of "The Blacksmith and Wheelwright," and Covering nearly the Whole Range of Blacksmithing, from the Simplest Job of Work to some of the Most Complex Forgings, Compiled and Edited by M. T. RICHARDSON.

Vol. I.	210 Illustrations.	224 pages.	12mo.	. . .	\$1.00
Vol. II.	230 Illustrations.	262 pages.	12mo.	. . .	\$1.00
Vol. III.	390 Illustrations.	307 pages.	12mo.	. . .	\$1.00
Vol. IV.	226 Illustrations.	276 pages.	12mo.	. . .	\$1.00

RICHARDSON—The Practical Horseshoer :

Being a Collection of Articles on Horseshoeing in all its Branches which have appeared from time to time in the columns of "The Blacksmith and Wheelwright," etc. Compiled and edited by M. T. RICHARDSON. 174 illustrations. . . . \$1.00

ROPER.—Instructions and Suggestions for Engineers and Firemen :

By STEPHEN ROPER, Engineer. 18mo. Morocco . \$2.00

ROPER.—The Steam Boiler : Its Care and Management :

By STEPHEN ROPER, Engineer. 12mo., tuck, gilt edges. \$2.00

ROPER.—The Young Engineer's Own Book :

Containing an Explanation of the Principle and Theories on which the Steam Engine as a Prime Mover is Based. By STEPHEN ROPER, Engineer. 160 illustrations, 363 pages. 18mo., tuck . \$3.00

ROSE.—Modern Steam-Engines :

An Elementary Treatise upon the Steam-Engine, written in Plain language; for Use in the Workshop as well as in the Drawing Office. Giving Full Explanations of the Construction of Modern Steam-Engines: Including Diagrams showing their Actual operation. Together with Complete but Simple Explanations of the operations of Various Kinds of Valves, Valve Motions, and Link Motions, etc., thereby Enabling the Ordinary Engineer to clearly Understand the Principles Involved in their Construction and Use, and to Plot out their Movements upon the Drawing Board. By JOSHUA ROSE, M. E. Illustrated by 422 engravings. Revised. 358 pp. . . \$6.00

ROSE.—Steam Boilers:

A Practical Treatise on Boiler Construction and Examination, for the Use of Practical Boiler Makers, Boiler Users, and Inspectors; and embracing in plain figures all the calculations necessary in Designing or Classifying Steam Boilers. By JOSHUA ROSE, M. E. Illustrated by 73 engravings. 250 pages. 8vo. . . . \$2.50

SCHRIBER.—The Complete Carriage and Wagon Painter :

A Concise Compendium of the Art of Painting Carriages, Wagons, and Sleighs, embracing Full Directions in all the Various Branches, including Lettering, Scrolling, Ornamenting, Striping, Varnishing, and Coloring, with numerous Recipes for Mixing Colors. 73 Illustrations. 177 pp. 12mo. . . . \$1.00





YC 18401

TP201
K5

60512

