

XH
.0851

vol. 7
1908

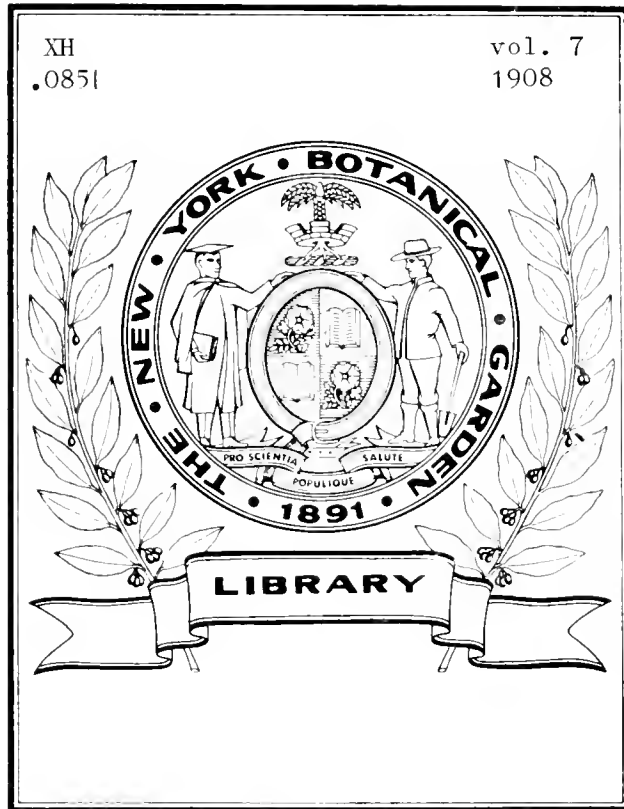

HORTICULTURE

INDEX TO VOL. VII.

Illustrated articles are marked with a *

Page	Page	Page
A		C
After adjournment...36, 100, 168, 201, 233, 264, 297, 329, 753, 817.	American Rose Society:—(Continued)	Cabbage growers, A boon for... 663
Alabama State Horticultural Soci- ety..... 170	—June show..... 662	*Calceolaria hybrida..... 585
Alaska-Yukon Pacific Exposition. 240, 854	American Seed Trade Associa- tion:—	—Culture of the..... 589
Albany Florists' Club..... 788	—Annual convention..... 857	Canadian postage discussion.... 140
*Allen, C. L..... 753	—Executive committee meeting.. 142	*Cattleya:—
Alleys, On the..... 861	—Secretary's announcement..... 726	—Gigas Sauderiana..... 854
American Apple Growers' Con- gress..... 788	*Anchusa Italica var. Dropmore.. 448	—Percivaliana Alva..... 57, 84
American Association of Nursery- men:—	Anniversary, An Interesting.... 753	—The most useful of the..... 722
—Program..... 721	Apples in the northwest..... 264	*White Mossiae..... 745
—President's address..... 784	—*Flowering..... 293	Carnations:—
—Secretary's report..... 786	—Show, National..... 480	*Afterglow, House of..... 102
—Treasurer's report..... 786	Appraiser's decisions....105, 238, 295, 490, 756.	*Andrew Carnegie..... 105
—Committee reports..... 786	*Aquilegias..... 231	—An interesting seedling..... 105
—Report continued..... 820	Arnold Arboretum, Notes from. 401, 437, 473, 591, 621, 653, 685, 717, 749, 781, 813, 845.	*Apple Blossom in October.... 135
American Association of Park Superintendents..... 408, 688	*Asmuss, George..... 368	*Bay State..... 617
—Preliminary program..... 820	Asperula..... 133	*Climax in October..... 135
American Breeders' Association.. 106	*Aster, A profitable..... 52	—Commercial..... 266
American Carnation Society:—	—Growing contest..... 333	—Exhibition at Cornell..... 337
—Rate to Washington..... 8	—A great..... 418	*Georgia, A vase of..... 104
—Preliminary announcement..37, *101	B	—Growers organize..... 367
*Fred H. Lemon; *A. M. Herr; Peter Bisset..... 101	Baccharis halimifolia.....*649, 655	*Harvard..... 104
—Convention at Washington..136, 169	Baltimore, Exhibition at..... 541	—Indoor culture of..... 210
—President's address..... 136	Bark effect and pussy willows... 526	—In New Bedford..... 104
—Secretary's report..... 137	*Baur, A. F. J..... 234	*Lloyd..... 7
—Judges' report; List of awards. 138	Berberis Thunbergii..... 365	Lieut. Peary..... 277
—The banquet..... 169	Bibliothèques horticoles, Les.... 690	*Marchioness..... 7
—What the grower should expect from the introducer of a new seedling..... 171	*Bisset, Peter..... 101	—New American in England.... 439
—Special points on carnation hy- bridizing..... 172	*Blackistone, Z. D..... 103	—Novelties at Wa-no-ka green- houses..... 135
*Experiments in carnation grow- ing by the U. S. Dept. of Agri- culture..... 204	Boiler manufacturing concern, A prosperous..... 645	—Points on field and indoor cul- ture of..... 327
—Points on carnation breeding in America..... 212,	Boston:—	*President Seelye..... 102
—Carnations registered...37, 65, 754	—Gardeners' and Florists' Club of, 64, 106, 202, 236, 265, 330, 374, 408, 442, *529, 562, 688, 754, 818,	*Singular flower, A..... 625
American Forestry Association.. 7	—Market exhibition..... 234, 295	—Temperatures..... 233
American Peony Society:—	—Rhododendron exhibition at, 754, 788	—Three promising..... 104
—Notice of annual meeting..... 721	*Spring show at..... 404	*Two new white seedlings.... 7
—Annual meeting..... 852	Botanic gardens and their use... 108	*Wa-no-ka in September..... 135
—Secretary's report..... 852	Bougainvilleas..... 261	—White Fair Maid..... 89, 104
American Rose Society:—	—*Glabra, An arbor of..... 257	Catalogues received..... 40, 110, 111, 143, 174, 206, 238, 270, 302, 339, 353, 414, 488, 534, 598, 727, 761, 824.
—Life membership certificates.. 9	Bread from stones..... 229	Celastrus orbiculatus..... 5
—Executive committee meeting. 64, 265	*Bremont, Martial..... 532	Celsia arcturus.....*161, 175
—Prizes offered....107, 141, 220, 332, 368.	*Bridle path, W. Roxbury park- way, Boston..... 713	Chatenay, M. Abel..... 852
—Philadelphia to Chicago..... 297	British horticulture...35, 95, 165, 230, 403, 472, 526, 591, 687, 749, 783, 845.	Chicago Florists Club...203, 235, 243, 330, 408, 659, 788.
*Art Institute, Chicago..... 368	*Brown, Charles J..... 809	—Gleanings from plant growers. 568
*Michell trophy..... 370	Buddleia variabilis Veitchiana... 632	—Jottings..... 602
—Annual meeting..... 406, 440	Buffalo Florist Club..... 235, 333, 688	—Spring plant trade in..... 725, 792
—President's address..... 406	Bulbs, Inferior Dutch..... 561, 594	Chionodoxas..... 687
—Secretary's report; treasurer's report..... 407	—*Spring bedding at Agricultural Dept., Washington, D. C..... 724	Chrysanthem, La..... 699
—The exhibition; Election of of- ficers..... 408	—Superfluous flowers..... 781	Chrysanthemum Society of Amer- ica..... 265
—The banquet..... 440	—Freight rate on..... 817	Chrysanthemum mildew..... 133
—The rose from a retailer's view 497	—Freight rate on Japan..... 849	Two good annual..... 477
—Secretary's statement..... 592	—The situation..... 817	Chrysantheum pumiceus..... 263
	Business changes.....14, 45, 75, 115, 147, 179, 213, 245, 275, 309, 343, 385, 419, 453, 504, 536, 561, 602, 627, 666, 694, 731, 763, 794, 819, 855.	Club and society notes...9, 42, 66, 107, 142, 174, 209, 236, 266, 300, 421, 442, 496, 533, 562, 592, 627, 661, 688, 721, 789, 821, 851.
	—Reverses, Recent..... 663	Codling moth, Controlling the... 189
		Competition fair and foul..... 67
		Connecticut Horticultural Society. *8, 61, 298, 375, 533, 720
		*Cook, George H..... 103

HORTICULTURE

Page		Page	Page
Court decision in customs house case.....	613	Editorials: (Continued)	
Cover illustration, Our.....	723, 781	Prosperity in full swing; The electric van in horticultural trade; An unequal struggle....	624
Crocuses in the grass.....	841, 849	Memorial day; Sunday closing; Limitations of the registration bureau.....	654
*Cumming, Alex.....	691	The trend of preference; A wise and patriotic measure; The amplitude of salesmanship.....	686
*Cyclamens in England.....	95	Unfrilled orchid growing; For the better development of New England.....	718
Fertilizing and selecting of the.....	167, 197	Floriculture enriched; An experience and its lesson; Merchandising methods.....	752
*Cypripedium Fairricanum hybrids.....	61	Co-operative sentiment should be encouraged; Cohesion is better than divergence.....	782
*Curtisii nobilior.....	653	"Bumper" crops and good times on the way; Unappreciated flower shows; Nurserymen headed right.....	816
Co-operation between wholesaler and retailer in times of over-production.....	755	The fall exhibitors; To arouse public interest; The national flower show.....	848
Correction, A.....	722	Elberon Horticultural Society.....	375
D		Engelman Botanical Club.....	106
Daily plant auction.....	345	Entire satisfaction.....	529
Daphne Cneorum.....	628	*Ernest, W. H.....	103
Dayton news.....	114	Euonymus alatus.....	97
Florists' Club.....	236	European crop conditions.....	70
Detroit Florist Club.....	8, 106, 141, 478, 720	Evil to be remedied, An.....	655
--Good example.....	539	Experiment Station, The Massachusetts.....	68
--Park board vs. San Jose scale.....	856	Express monopoly, The.....	849
--Retailers' view.....	634	F	
Dingee & Conard Co.'s, Heard at.....	264	Fashion in flowers.....	327
During recess.....	109, 421, 536, 789, 824	*Fertilizers, A fern fed with soluble.....	527
E		--and manures in the greenhouse, Misuse of.....	751
*Easter, 1908.....	465	--About, and their use.....	99
--Market reports.....	571, 573, 581	--Commercial, sized up.....	233
--Prospects.....	503	--Mechanical fineness of.....	197
--Suggestions.....	502	--Soluble.....	253, 264, 559
*Echinops.....	401	--The question.....	489
Editorials: --		--Weights and areas for.....	33
--1908; The scope of school horticulture; What we promise....	6	--Fertilizing while watering.....	63
--The carnationists' opportunity; Get "a move on"; Helping one another.....	31	Fire record.....	836
--Intelligent plant feeding; Profitless work; Making a record....	62	*Flora's harbingers of spring.....	471
--Salutation; Two standards of value; The catalogue season....	98	Florists' Mail Association.....	408
--Costly carelessness; A broad gauge course; To demonstrate decorative value.....	134	--Opportunity for.....	382
--The nomenclature of carnation sports; Again the charter; Essentials in hybridization; A rose grower's duty.....	166	Flower market reports.....	17, 45, 77, 84, 117, 149, 181, 213, 245, 277, 309, 345, 385, 421, 453, 507, 541, 605, 605, 637, 669, 701, 733, 765, 797, 829, 861
--The passing of "sterilis"; A proposed rose bulletin; Vicissitudes of the violet; An inevitable result.....	200	--market proposed, A new.....	603
--Exclusively for the commercial florist; Planning the business campaign; To safeguard the forests.....	232	Flower spike, A sixty million....	724
--The carnation growers' burden; The forcing bulb industry; Old style houses at a disadvantage....	262	Forest lands, Exempting from taxation.....	189
--The single violet a winner; The gardener of the future; Where education points the way.....	296	*Freeman, J. R.....	103
--Reciprocity; Vicissitudes of Fashion; A duty of every florist.....	328	Fungicides, insecticides and spraying.....	766
--Of value to rose growers; What an organization can do.....	366	G	
--A story well told; Reporting the exhibition; The remedy....	402	Galloway, Dr. A question for.....	233
--The rose in the ascendant; Progress; A live question....	438	*Garden making, Art and nature in.....	229
--Seasonable good wishes; Position fairly won; An opportunity neglected.....	476	Gardeners, Movements of.....	269, 536, 824
--The Chinese primrose; The fate of the sluggard; A superfluous commodity.....	528	Geraniums, Four best zonal.....	595
--Easter, 1908; About "lap seam" boilers; The early flowering sweet pea.....	560	Ghent, International Horticultural Exposition at.....	234
--A "tip" for the fall show. A proposed insecticide bill; The problem of the forcing bulb.....	590	Quinquennial, Trip to.....	415
		--Show.....	561, 851
		--Some azalea awards at.....	699
		Ginseng growers.....	107
		*Gladioli, Ruffled.....	165
		Glass marble, The.....	516
		Glory bell.....	753
		Grass, A new ornamental.....	688
		Greenhouse, The proper size to grow roses for commercial purposes.....	483
		Greenhouses building or contemplated.....	26, 51, 85, 125, 157, 190, 222, 254, 277, 318, 351, 393, 420, 461, 516, 549, 580, 614, 645, 677, 696, 725, 773, 804, 837, 869
		Greenwich Gardeners' Society.....	107
		*Gude, W. F.....	103
		*Guttman, A. J.....	605
		Gypsy moth fight, \$250,000 for....	270
		H	
		Hail losses.....	461
		--Record.....	486
		*Hammond, Benjamin.....	369
		Happy gardener, The.....	84
		*Harford's new superintendent of streets.....	691
		Heard in the anteroom.....	367
		Heating apparatus, New.....	26, 85, 190
		Herbaceous border, The present care of.....	403
		*Herr, A. M.....	101
		*Herr, Mrs. A. M.....	139
		Hippophae rhamnoides.....	167
		Horticulturist, The ideal.....	199
		*House, A staunch.....	189
		Huntington Horticultural and Agricultural Society.....	203, 300
		*Huss, J. F.....	5
		Hydrangea arborescens grandiflora.....	231
		--Controversy, The.....	39
		--Question settled.....	198
		Hydrocyanic gas for white fly.....	725, 815
		I	
		Ilex crosses.....	329
		Illinois State Floral Association... ..	266
		--State Horticultural Society.....	298
		Incorporated.....	10, 115, 143, 175, 213, 245, 309, 382, 418, 453, 504, 571, 603, 655, 677, 695, 727, 757, 792, 821, 859
		Inspection laws, Good results of... ..	52
		Iowa State College, New forester at.....	108
		Insecticides, Proposed law affecting.....	856
		J	
		Jamaicaway, Olmsted Park, Boston.....	225, 231
		*Jensen, J. E.....	369
		June, A song for.....	817
		K	
		*Kill, Leonard.....	106, 369
		Killarney's Chicago home.....	536
		--Mildew on.....	753
		*Kramer, F. H.....	103, 531
		L	
		*Lemon, Fred H.....	101
		Lenox Horticultural Society.....	141, 378
		Letter of gratitude, A.....	7
		Lettnice, Boston Head at Irondequoit.....	85
		*Leuthy, A.....	594
		Level, A low priced.....	861
		Liberal offer, A.....	564
		Library Notes.....	201, 233, 416, 757
		Lilies, Longiflorum vs. Multiflorum.....	787
		--*More about Formosa.....	499
		--The qualities of Formosa.....	448
		--Shy of bloom.....	397
		Lily bulbs, Home production of... ..	105
		Louisiana State Horticultural Society.....	141
		M	
		Madison, N. J., Personal items from.....	859
		March, A song for.....	329
		Marguerites, Improving the.....	593
		Marylanders in Holland.....	632

HORTICULTURE

Rose:—(Continued)			
—Cherokee	141		
—Gruss an Tepfitz	371		
—Houses, Large	364		
—*Madonna	377		
—*Marshall P. Wilder	483		
—*Mrs. Jardine	377		
—*Mrs. Potter Palmer	377		
—*My Maryland	377		
—New book on the	367		
—*Queen Beatrice	376		
—*Rhea Reid	376		
—*White Killarney	376, 433		
Roses:—			
—A dethorning instrument for	233		
—At Westerly, R. I.	370		
—From sand and cuttings	295		
—Notes on newer	371		
—Pot, for Easter	491		
—Remembrances of some pot	655		
—Some now, worth having	376		
—Under glass	815		
*Roy, David F.	100		
Royal Gardens, Kew	35		
S			
Salem Cherry Fair	754		
Salvia Zurich	61		
Sciadopitys verticillata, A method of propagating	696		
—Propagation of	791		
*Scarboro pond	681		
*Screen, A practical	623		
San Jose scale	630		
Secretaries for 1908	170		
Seedsmen's League, Wholesale	338		
Seed trade	10, 40, 70, 112, 142, 206, 238, 270, 302, 338, 414, 446, 488, 534, 566, 598, 630, 694, 726, 761, 795, 824, 856		
—Maine views on free	72		
Selling, The art of	689		
Shamrock, The Irish	329		
—The Japanese	329		
Shrub chat	596		
*Simpson, Robert	369		
—*A chat with	656		
Small fruits	285, 484		
*Smith W. R.	103		
Society launched, A new	380		
Society of American Florists:—			
—President Traendly's greeting	9		
—New directors	9, 39, *65		
—Executive board meeting	39, 300, 408, 478		
—New officers	65		
—State vice-presidents	65, 107, 688		
—Ladies' Society of American Florists	100		
—A bustling member	412		
—The question of plant registra- tion	658		
—Census committee	688		
—Supt. C. H. Keitsch's notice	720		
—Reduced rates to Niagara	789		
—National Flower Show premium list	140, 208, 300, 375		
—Call for meeting	266		
—Committee of Fifty meeting	626		
—Department of plant registration	156, 530, 562, 592		
Southampton Horticultural Society	58, 107, 266, 333, 479		
Soil, A chemical study of some greenhouse	758		
—Fertility, maintaining	53		
Some wise advice	529		
—New things seen in an old coun- try	410, 481		
Sprig from the spice bush, A	849		
Springfield, Ill., The city beautiful movement in	482		
Steamer departures	762, 794, 826, 858		
St. Louis Florist Club	64, 235, 374, 533, 688, 819		
—Horticultural Society	141, 236, 754		
—Flower show	318		
*Stock Queen Alexandra	589		
Storage Company must pay	24		
*Sweet peas at Christmas	33		
—Popularity of	10		
—*Watchung, Early white	553		
—*Winter flowering	563, 628		
T			
Tarrytown Horticultural Society	9, 109, 170, 299, 442, 626, 754, 818		
Testimonial, A	113, 529		
*Temple show, The	787		
*Thilow, J. Otto	481		
Toledo Florists' Club	592		
—Florists in Tiffin and Fostoria	203		
—Notes	345		
—Some florists	333		
Tomatoes under glass	96		
Tribune Horticole	367		
Tri-City Florists' Association	8		
Twenty-eighth street, News of	605		
Twin City Florists' and Garden- ers' Club	141, 266, 300, 592		
—Notes from	421, 627		
V			
Vegetables under glass	253		
—*Greenhouse grown	272		
Viburnum opulus	261		
*Violet Boston, New	29		
—*House of	36		
W			
*Waters, T. E.	369		
Washington, Florists' Club of	42, 64, 107, 203, 331, 659, 788		
*Welch, P.	369		
*Wellesley, Horticultural study at	157		
Western New York Horticultural Society	38, 176		
West Grove, Pa., A burglary at	297		
Winnipeg Florists' Association	478		
Wireless from Robert Craig	340		
—Picked up by	495		
Wood preservation for horticul- turists	750		
Worcester County Horticultural Society	38, 332		
*Wreath, A well-made	306		
Y			
York experiment station, Nebras- ka, Notes from	621		

THE INDEX WHICH APPEARS ON THESE PAGES HAS A VALUE BEYOND ITS ORDINARY PURPOSE AS A GUIDE TO THE CONTENTS OF VOLUME 7. CONSIDERING THAT THE ABOVE LIST OF SUBJECTS COVERS A PERIOD OF ONLY SIX MONTHS—HALF A YEAR—COSTING THE SUBSCRIBER FIFTY CENTS. IT IS, WE THINK, A STRONG PRESENTATION OF THE VALUE WHICH HORTICULTURE IS RETURNING TO ITS SUBSCRIBERS. CAN YOU DO BETTER THAN TELL YOUR FRIENDS ABOUT IT?

HORTICULTURE

Vol. VII. JANUARY 4, 1908 No. 1



GOLD MEDAL DECORATIVE GROUP AT EXHIBITION OF NATIONAL CHRYSANTHEMUM SOCIETY OF ENGLAND
By H. J. Jones.

*Devoted to the
FLORIST, PLANTSMAN,
LANDSCAPE GARDENER,
and
Kindred Interests*

*Published
EVERY SATURDAY
At 11 Hamilton Place,
BOSTON, MASS.
Subscription, \$1.00*

CARNATIONS - Rooted Cuttings

Healthy, well-rooted stock the product of the most reliable growers of this locality

	Per 100	Per 1000		Per 100	Per 1000		Per 100	Per 1000
White Enchantress,	\$6.00	\$50.00	Enchantress,	\$2.50	\$20.00	Harlowarden,	\$2.00	\$18.00
White Perfection,	3.00	25.00	Helen Goddard,	2.50	21.00	Patten,	2.50	20.00
White Lawson,	2.00	18.00	Lawson,	2.00	18.00	Fenn,	2.00	18.00
Queen Louise,	2.00	18.00	Beacon,	6.00	50.00	Red Sport,	2.00	18.00
Winsor,	6.00	50.00	Victory,	3.00	25.00	Boston Market,	2.00	18.00
Aristocrat,	6.00	50.00	Craig,	3.00	25.00	Joost,	2.00	18.00
Rose Pk Enchantress,	3.50	30.00						

NEW CROP SEEDS

ASPARAGUS PLUMOSUS NANUS, Greenhouse Grown, Hand Selected.

CUT BOXWOOD, 50 lb. cases, \$15.00 per 100 lbs. | POINSETTIAS, extra value, \$15.00 and \$25.00 per 100 lb.

S. S. PENNOCK-MEEHAN COMPANY, "THE" Wholesale Florists of
1608-1620 Ludlow Street, PHILADELPHIA

WINSOR and WHITE ENCHANTRESS Strong Rooted Cuttings Now Ready For Delivery

WINSOR has proved to be the finest carnation in the light pink class. We sold a large quantity of it last year, but there will be a much larger sale for it this year. At the English Carnation Show held in December, it was the winner in the light pink class. It is doing well everywhere and will supplant everything in that color.

WHITE ENCHANTRESS will occupy the same position among white carnations that Enchantress does among flesh pinks. It has all the good qualities of the common Enchantress,—long stem, earliness, large size, freedom, etc. In our opinion, it is by far the best white carnation ever introduced.

We have a splendid stock of both Winsor and White Enchantress ready for immediate delivery, and will guarantee perfect satisfaction with the cuttings supplied. Do not wait, because the demand for these varieties is bound to be enormous. Order early, while we can promise immediate delivery, and secure gilt-edged stock. We have a large stock of both of these varieties, and all our cuttings are heel cuttings, taken from flowering stems. On account of the quantity that we are growing, we are not obliged to over-propagate, and our stock is in the most perfect and healthy condition.

Strong rooted cuttings from sand, \$6 per 100, \$50 per 1000. Extra strong transplanted cuttings from soil, \$7.50 per 100, \$60 per 1000. Strong established pot-grown plants \$9 per 100, \$75 per 1000.

F. R. PIERSON CO., - Tarrytown-on-Hudson, - NEW YORK

Select Stock of Strong Well Rooted Carnation Cuttings.

	Ready Now.	Per 100	Per 1000
Andrew Carnegie, scarlet			
Harlowarden	\$12.00	\$100.00	
Aristocrat, bright cerise	6.00	50.00	
Winsor, pink	6.00	50.00	
Beacon, orange scarlet	6.00	50.00	
White Enchantress, pure white	6.00	50.00	
Welcome, pink	6.00	50.00	
Red Chief, Christmas scarlet	6.00	50.00	
Rose Pink Enchantress	3.00	25.00	
White Perfection	3.00	25.00	
Enchantress	3.00	25.00	
Daybreak Lawson	3.00	25.00	
Victory, scarlet	3.00	25.00	

CHICAGO CARNATION COMPANY,
A. T. PYFER, Mgr. JOLIET, ILL.

Carnation Cuttings

Both standard varieties and novelties. Stock guaranteed to be first-class. Address,

S. S. SKIDELSKY

1741 North 18th Street, Philadelphia

CARNATIONS

White Enchantress R. C. this stock originated with and grown by me is the very best, \$6.00 per 100, \$50.00 per 1000. Enchantress, light pink, \$2.50 per 100, \$20.00 per 1000. Lawson, \$2.00 per 100, \$15.00 per 1000. Lord, light pink, \$3.00 per 100, \$25.00 per 1000. Queen, white, \$2.00 per 100, \$15.00 per 1000. The Belle, \$2.00 per 100, \$20.00 per 1000.

FRANK H. KIMBERLY,

631 Townsend Avenue, New Haven, Conn.

JOHN E. HAINES Bethlehem, Pa.

is the place to order rooted-cuttings of the following varieties for 1908.

	Per 100	Per 1000
John E. Haines, red		
Imperial variegated		
Pink Imperial, Pink	\$6.00	\$50.00
Enchantress, Light Pink		

Place your orders early for Jan. delivery.

CARNATIONS ROOTED CUTTINGS

Winona, color, true clear pink, comes nearest to Fiancee but a different type flower. Growth on order of Scott but vastly improved in every respect. Early flowers in quantity and on long stems. Does not burst its calyx. Fine, shapely, active growth. In color and productiveness it is without an equal. Orders booked now and filled in strict rotation. \$12 per 100, \$100 per 1000.

White Perfection, pure white. We have a large stock. \$3 per 100, \$25 per 1000.

F. DORNER & SONS CO.
LA FAYETTE, IND.

1908—TOREADOR—1908

Our new seedling Carnation. In color, a very much improved Prosperity, with the addition of strong stiff stems. The finest novelty for 1908. Awarded first-class certificate Toronto meeting of the American Carnation Society. Write us for further information.

The H. Weber & Sons Co., Oakland, Md.

A PENNY SAVED IS WORTH TWO EARNED



Save your Pinks from Splitting by using the

M. & D. ARTIFICIAL CALYX

Free Sample. Send for one and be convinced of its merits.

MAXFIELD & DIMOND

P.O. Box 304 D WARREN, R.I.



Pat. Sept. 18-06

CHRYSANTEMUMS

Novelties from all over the world. Largest collection in America. Earliest delivery

NATHAN SMITH & SON
Adrian, Mich.

CATALOGUE OF

New Chrysanthemums Roses, Etc.

Now ready, I am headquarters for the new singles, and carry the cream of the world's novelties. If you are interested send for my list. It's yours for the asking.

CHARLES H. TOTTY
Madison, - - - N. J.

WE are now booking orders for Grafted and Own Root Rose stock.

A. N. PIERSON
CROMWELL, - - - CONN.

GLADIOLI

I can satisfactorily supply your wants for Gladioli for forcing or outdoor planting. Mixtures, color sections or named varieties of exceptional beauty.

Write for Prices

ARTHUR COWEE
Gladiolus Specialist
Meadowvale Farm, BERLIN, N. Y.



For Easter Forcing

RHODODENDRONS fine plants, shapely bushy specimens with twelve or more buds. **\$1 each; \$11 per doz.; \$90 per 100**

HARDY AZALEA MOLLIS a plant that is becoming more popular every season for forcing, if you have never used it try a few as an experiment. We offer bushy well budded plants 15 in. high **\$4.50 per doz.; \$35 per 100**

DEUTZIAS FOR FORCING

STRONG, FIELD GROWN PLANTS

LEMOINEI suitable for 6 or 7 in. pots **85c per doz.; \$6 per 100** **GRACILIS** suitable for 6 or 7 in. pots **85c per doz.; \$6 per 100**

GRACILIS ROSEA suitable for 6 or 7 in. pots **85c per doz.; \$6 per 100**

For a full and complete list of all seasonable stock see our new **Quarterly Wholesale List** issued January 1st

HENRY A. DREER

714 Chestnut Street, : PHILADELPHIA

LADY GAY

And other Rambler Roses.

CYCLAMENS

Finest specimen Plants ever offered.

\$36.00 per dozen

THOMAS ROLAND

Plant Grower

NAHANT, - - MASS.

DAHLIAS

A long list of desirable varieties at 3c each. Write for list.

A. B. DAVIS & SON, INC.
PURCELLVILLE, VA.

DAHLIAS.

Now is the time to place your order for bulbs which will insure you getting named varieties in any quantity; prompt delivery.

DAVID HERBERT & SON,

Successors to L. K. Peacock, Inc.
ATCO, N.J.

100,000 DAHLIAS

Premium Stock, guaranteed true to name. **500,000 large Flowering Gladioli**, hundreds of colors and variations mixed. Wholesale prices on application. Order now for spring delivery. Catalogue free.
J. L. MOORE, Northboro, Mass.

PURE WHITE ENCHANTRESS

ROOTED CUTTINGS

\$6.00 per 100 \$50.00 per 1000

JACOB SCHULZ

644 4th Ave., LOUISVILLE, KY.

JOHN WATERER & SONS, Ld.

American Nursery, Bagshot, England

Are Specialists in the

REALLY HARDY VARIETIES

of Rhododendron Hybrids and in Select Varieties of Hardy Border Plants.

NEW NEW

RAMBLER ROSE "NEWPORT FAIRY"

To be disseminated Spring, 1908. Ask for illustrated pamphlet and prices

JULIUS ROEHRS CO., Rutherford, N.J.

ROSES

Selected Stock for Forcing **CRIMSON RAMBLER and DOROTHY PERKINS**

3 to 4 ft. \$1.50 per 10, \$12.00 per 100; 4 to 5 ft. \$2.00 per 10, \$15.00 per 100

HYBRIDS - All Leading Varieties, \$1.50 per 10, \$12.00 per 100
General Catalog and Trade Lists on Application

The NEW ENGLAND NURSERIES, Inc., Bedford, Mass.

HYDRANGEA OTAKSA

FIELD CROWN

6c, 8c, 10c and 15c each by the dozen or hundred. Fine stock.

BAUR FLORAL CO., Erie, Pa.

Rose Hill Nurseries

Established 40 Years

New and Rare Plants

NEW ROCHELLE, N. Y.

New York Office, Siebrecht Building, 425 Fifth Avenue

Hardy Rhododendrons Azaleas, Conifers, Clematis, H. P. Roses, Shrubs and Herbaceous Plants from our **HOLLAND NURSERIES**

Prices Moderate

P. OUWERKERK, 216 Jane St., Weehawken Heights, P. O. No. 1, Hoboken, N. J.

Viburnum Plicatum

Berberis Thunbergii } **LARGE STOCK.**
Hydrangea Pan Grand, }
Honeysuckle Heckrottii } **Send for Prices.**

The CONARD & JONES CO.
WEST GROVE, PA.

Easter Azaleas and Spring Forcing Plants



Our stock this season is handsomer than ever. Anybody in want of a quantity will do well to inspect our plants before placing their order. We have only popular American varieties: Schryveriana, Niobe, Paul Weber, Prof. Wolters, Raphael, Simon Mardner, Vervaeana, Louis de Kerchove, Mme. Van der Cruyssen, Deutsche Perle, Dr. Moore, John Llewelyn, Mme. Cam. Van Langenhove, Mme. Jos. Vervaeae, Paul de Schryver, Memorie de L'Van Houtte, Sigismund Rucker and others.

	Per doz.	Per 1000		Per doz.	Per 1000
8-10 in. diam.	\$3.50	\$25.00	15-16 in. diam.	\$9.00	\$75.00
10-12 "	4.50	35 00	16-18 "	12.00	90.00
12-14 "	6.00	45.00	18-20 "	25.00	200.00
14-15 "	7.50	60.00	20-24 "	36.00	300.00

Order early to save heavy express charges; impossible to ship by freight in cold weather.

FORCING ROOTS AND POT CROWN SHRUBS

	Doz.	100	1000		Doz.	100	1000
Azalea Mollis, \$4.00, \$9.00, \$12.00				Gladiolus, The Bride			\$7.50
" " standard form 12.00				" rubra			6.50
" " chinensis 12.00				Kalmia latifolia, fine budded plants, \$9.00, 12.00			
" " " Anthony Koster 12.00				Lilacs pot grown 9.00			
" Rustica 12.00				Lily of the Valley, Berlin Pips 14.00			
Very handsome budded plants.				" Hamburg Pips 12.00			
Crataegus, Paul's Scarlet Double scarlet Hawthorn) pot grown, \$12.00, 18.00				Spiraea, Blondin			5.00
Dielytra spectabilis, large clumps, \$6.00				" Compacta 4.50			4.50
Deutzia gracilis, pot grown Lemoinei 15.00				" Gladstone extra large clumps 7.00			4.50
Rhododendrons, handsome budded plants in fine forcing varieties, \$2, \$12, \$15, \$18, \$24, \$30 per dozen.				" Japonica 4.50			10.00
				" Queen of Holland 10.00			10.00
				" Washington 10.00			
				Viburnum opulus (Snowball - bush form, pot grown 6.50			

Roses Grown in Our Nursery for Easter Forcing

- BABY RAMBLERS, tree form, pot grown, 50c. each
- Bushy form fine field grown plants
- CLOTHILDE SOUPERT, field grown, 2 year old
- DOROTHY PERKINS, strong field grown plants, 2 years old, 7-8 feet
- HERMOSA, field grown, fine for pots, 2 years old
- RED KAISERIN, strong 2 year old field grown plants

Dozen	100
\$5.00	\$15.00
2.00	12.00
1.50	20.00
3.00	12.00
1.50	25.00
3 50	

- LADY GAY, strong field grown plants, with well ripened wood, 2 years
- H. P. ROSES, imported, field grown, 2 years old
- Capt. Christy, Duchess of Edinburgh, Gen. Jacqueminot, Mme. Gabriel Luizet, Mrs. John Laing, Perle des Blanches, Ulrich Brunner, Caroline Testout, Frau Karl Druschki, La France, Magna Charta, Paul Neyron, Rothschild.

Dozen	100	1000
\$3.50	\$25.00	12.00
		\$100.00

KENTIAS

The handsomest lot in the country. All sizes, from 15 inches to 15 feet. Inspect our stock before buying.

BOXWOOD, Standard

All sizes ... from \$1.00 to \$5.00 each

BOXWOOD, Pyramidal

These plants are conceded to be the finest ever imported to this country. (Exceptional value.)

2 ft. \$.75 each	4 ft. \$ 3.00 each
2 1/2 ft. 1.00 each	4 1/2 ft. 4.00 each
3 ft. 1.50 each	5 ft. 5.00 each
3 1/2 ft. 2.00 each	6 ft. 6.00 each

BOXWOOD, Bush

Handsome, bushy specimens.

10-12 in. 150 each	15-18 in. 350 each
12-15 in. 250 each	18-22 in. 500 each

BAY TREES

We have a large number in all sizes. Ask for prices.

VISITORS INVITED.

ASK FOR CATALOGUE.

BOBBINK & ATKINS, Nurserymen and Florists, Rutherford, N. J.

Just Received in Splendid Condition

15,000 AZALEAS

in all sizes and varieties

25c. up to \$2.00 each

Also Kentias, Rubbers, Araucarias, Pandanus, Boxwood, Euonymus, Crotons, Areca and Eurya latifolia.

Extra good value in large

Specimen and Decorative Palms

A. LEUTHY & CO.

Perkins Street Nurseries, Roslindale, Mass.

GODFREY ASCHMANN

Importer and Wholesale Grower and Shipper

of Ar. ... Kentia ... Pandanus ... Crotons ...

1012 Ontario St., Philadelphia

ANTON SCHULTHEIS

Wholesale Plant Grower,

College Point, - New York.

Price List of Foliage, Flowering and Decorative Plants sent free on application.

SEED—COCOS WEDDELIANA

Specially Splendid Seed

\$4 per 100 \$36 per 1000

Carriage free. Cash from unknown correspondents.

SANDER & SONS. Bruges, Belgium.

AUGUST ROLKER & SONS

Supply the trade with

PLANTS AND BULBS

For greenhouse or outdoor use, imported to order. Send for estimate. Address—

31 Barclay St., or P.O. Box 752, New York.

AZALEAS (HENT-MOLLIS And Natives

PYRAMIDAL BOX LARGE STOCK All Sizes

ROSES STRONG PLANTS--BEST VARIETIES

Send for List and Prices

Acres of HERBACEOUS PERENNIALS. LARGEST VARIETY IN NEW ENGLAND

Send for Catalogues. **BAY STATE NURSERIES** NO. ABINGTON MASS.

A New Disease of the Peony

To the amateur horticulturist, that is, one who grows plants for pleasure rather than for money, the peony has been, and probably always will be, a great favorite. The dark green foliage throughout a long growing season, the large flowers, the endless number of varieties, its comparative freedom from disease and the small number of insects which trouble it, have all contributed more or less to its deserved popularity. Hence it is that peony-lovers in and about Cambridge, Mass., have viewed with dismay the destruction of many of their favorite plants the past season by a new disease.

Among the first symptoms of the disease are wilting of the leaves and loss of green color in the stalks. On digging away the earth the roots are found more or less decayed. In a majority of cases, though not always, the disease is fatal. Specimens of the diseased plants have been sent to the experiment stations, but so far no satisfactory conclusions have been reached. Probably some bacterium or fungus is the cause of all the trouble, but the particular species has not yet been determined, nor is it known whether infection takes place above or below the ground.

If it should be proved that the disease is spread by spores that are blown about by the wind and germinate on reaching the leaf, the remedy may be simple, for spraying with Bordeaux mixture or other fungicide would undoubtedly be sufficient to protect the plants from future attacks. But it appears more likely that infection takes place in the soil and that the root is the first part of the plant to undergo destruction. In this case to insure the immunity of the plant will not be so easy.

If the cause of the trouble is a species which is usually parasitic and lives in the soil, the grower of peonies has some reason for being alarmed as the control of such species is difficult. They are seldom kept from doing harm except by rotation of crops as the case of onion smut, club-foot of cabbage and potato scab. Yet it may be that the peony disease is only a saprophytic form (that ordinarily lives on decaying matter only) which has become under favorable conditions temporarily a parasite. If such is the case an amelioration of the soil by applications of lime, sand, or other material may be sufficient to prevent further ravages.

Prof. M. L. Fernald of the Botanic Garden, Cambridge, who has made an extended study of the geographical distribution of plants as affected by their physical environment, says that many members of the Ranunculaceæ (Buttercup Family) to which the peony belongs, delight in a limestone soil. So far as known the peony disease has appeared only in clayey soils

where there is, presumably, only a small amount of lime. And it may be that the peony having been transported from its natural environment has become so weakened that the saprophytic organisms have been able to attack the last plant before natural decay of the roots has begun.

In the meantime, while we await the decisions of the plant pathologists who are studying the disease, we advise the peony-grower who wishes to save his plants to begin spraying all parts of the plant above the soil as soon as the leaves appear in the spring. This will prevent any infection by spores blown about by the wind. To retard any further spread of disease in the soil, lime should be broadcasted at the rate of fifty to seventy-five bushels per acre and spaded in thoroughly as soon as the ground can be worked. These preventives may not prove to be an unqualified success, but they are the best known at present.

E. W. MORSE.

Celastrus orbiculatus Thun.

Even now this Asiatic cousin of our own Bitter Sweet or Roxbury Wax Work is showy with its wealth of crimson seeds. Although introduced into this country more than thirty years ago it is by no means as commonly planted as it deserves. A twining shrub, native to China and Japan, it attains a height of ten to fifteen feet and in habit closely resembles the Wax Work though it is a more vigorous plant and a more rapid grower. The leaves are usually two to three inches long, dark yellow-green on the upper surface and turn to yellow before falling in the autumn. The flowers are small, yellow-green, borne in axillary clusters and are of little ornamental value. The fruit is very abundant and ripens in early autumn. It is globose and about one-quarter inch in diameter. The pod is a clear yellow and the aril of the seed crimson. The fruit is smaller than that of the Roxbury Wax Work and is less showy until the leaves have fallen because the fruit stalks do not lift it above the leaves. Then the aril is lighter in color and somewhat less striking than that of the Wax Work. However, the greater abundance of fruit more than compensates for these deficiencies. As to persistence, the pod usually remains until late fall or early winter, while the seed with its crimson aril not infrequently remains until late winter. It is not particular as to soil or situation and it grows in the shade as well as in the sun. It is especially good for covering rocks and for twining over walls and fences. Then it is well adapted to house-decoration, a purpose for which it is made to serve by the Japanese.

Celastrus orbiculatus is figured and described in "Garden and Forest", vol. III, pp. 550-551.

Daniel A. Clarke.

HORTICULTURE

VOL. VII

JANUARY 4, 1908

NO. 1

PUBLISHED WEEKLY BY
HORTICULTURE PUBLISHING CO.
 11 Hamilton Place, Boston, Mass.

Telephone, Oxford 292
 WM. J. STEWART, Editor and Manager

SUBSCRIPTION PRICE

One Year, in advance, \$1.00: To Foreign Countries, 2.00; To Canada, \$1.50

ADVERTISING RATES

Per Inch, 30 inches to page \$1.00.

Discounts on Contracts for consecutive insertions, as follows:

One month (4 times) 5 per cent.; three months (13 times) 10 per cent.;

six months (26 times) 20 per cent.; one year (52 times) 30 per cent.

Page and half page spaces, special rates on application.

COPYRIGHT, 1907, BY HORTICULTURE PUB. CO.

Entered as second-class matter December 8, 1904, at the Post Office at Boston, Mass., under the Act of Congress of March 3, 1879.

CONTENTS

	Page
FRONTISPIECE—A Gold Medal Decorative Group	
A NEW DISEASE OF THE PEONY—E. W. Morse...	5
CELASTRUS ORBICULATUS—Daniel W. Clarke...	5
TWO NEW WHITE CARNATIONS—Illustrated....	7
NEWS OF THE CLUBS AND SOCIETIES	
American Forestry Association.....	7
New York State Fruit Growers' Association—	
American Carnation Society—Connecticut Horti-	
cultural Society, Portrait Pres. J. F. Huss—Det-	
roit Florist Club—Tri-City Florists' Association	
—Newport Horticultural Society.....	8
Society of American Florists, Portrait, Secre-	
tary W. N. Rudd—American Rose Society—	
Tarrytown Horticultural Society—Club and	
Society Notes.....	9
SEED TRADE.....	10
OBITUARY	
George Wainwright—John Clark, Portrait—Reu-	
ben H. Warder—Myrtle Rosenfield—Walter	
White.....	12
Francois Quinlan—Arthur B. Howard—Everett B.	
Clark—Mrs. W. H. Gunther—Mrs. Julius E.	
Schray.....	13
FLOWER MARKET REPORTS	
Boston, Buffalo, Detroit, Indianapolis, Newport,	
New York, Philadelphia, Washington, Twin	
Cities.....	17
STORAGE COMPANY LIABLE.....	24
THE POTATO—Walter L. Jagger.....	25
MISCELLANEOUS	
A Letter of Gratitude.....	7
Popularity of the Sweet Pea.....	10
List of Patents.....	10
Plant Imports.....	10
Incorporated.....	10
A New Firm.....	11
Philadelphia Notes.....	14
Personal.....	14
News Notes.....	14, 15
Business Changes.....	14
Incorporated.....	14
A Seed Trade Tribute, Illustrated.....	14
New Retail Flower Stores.....	15
Greenhouses Building or Contemplated.....	26
New Heating Apparatus.....	26
SUPPLEMENT—Index to Vol. VI.	

which all should strive and every forward step in this direction will hasten the realization of

A Happy New Year.

The scope
of school horticulture

We read of one teacher in a school where gardening has been taught who finds fault with some of the boys who prefer

growing vegetables to flowers and advocates compulsory flower culture on the ground that the growing of vegetables fosters the mercenary spirit, whereas the object should be to teach the children how to appreciate the beauties of nature. As we understand it the primary object in school horticulture is to educate the children away from the idea that the city is the only place for those who seek a road that leads on to fortune, to develop in them an appreciation of the comforts and the opportunities that a country life offers, to expand their minds on healthy lines, to cultivate the heart, brain and hands and to build up character as it can only be built up by association with nature. As with all other movements of a philanthropic sort there is danger of theorists and extremists nullifying much well-meant effort in this school-garden movement. The school teacher who objects to the boys' vegetable gardens should be passed on to another job.

What we
promise

It is our purpose to make the coming volume of HORTICULTURE better than any of its predecessors in every possible respect. This means that it will be still more emphatically the foremost horticultural journal of America. As heretofore its policy will be to serve the interests of and promote the fraternal spirit among those engaged in horticulture out of doors or under glass and the allied industries by securing for its reading columns the experience and views of the most intelligent, progressive and successful plantmen, florists and gardeners on practical subjects and presenting weekly full reports of the doings of all local and national organizations devoted to horticultural advancement and education. Its influence and support will be extended to every movement tending to elevate and dignify American horticulture. All news of value to the trade from every section of our country and abroad, market and crop reports and forecasts, current prices, etc., will be carefully compiled for our weekly issues. Editorials on reasonable topics and signed contributions from the foremost horticultural writers and educators on matters of scientific and artistic interest will fill a prominent place. On our staff of writers for the coming year are included Jackson Dawson, Daniel A. Clarke, J. A. Pettigrew, Theodore Wirth, A. Hans, T. D. Hatfield and other eminent authorities on tree and landscape topics, Edwin Lonsdale, Robert Craig, Robert Cameron, D. McIntosh, Kenneth Finlayson, George Moore—all plantmen of high repute, E. O. Orpet, James Hutchinson and John E. Lager on orchids, J. E. Simpson on roses, Wm. Sim on violets, F. J. Rem on herbaceous plants, Edw. McKendry on chrysanthemums, Wilfrid Wheeler on small fruits, Dr. George E. Stone on vegetables under glass, R. L. Adams on plant diseases, Dudley M. Pray on fertilizers, and many other eminent writers on special subjects, George C. Watson and our rapidly growing staff of local correspondents, and the foreign field will be covered by W. H. Adsett, Harry H. Thomas, C. Harman Payne, Edgar Elvin, F. Gomer Waterer and other interesting contributors from time to time. We intend that subscribers to HORTICULTURE shall have the best dollar's worth ever given in horticultural literature.

1908

To our readers, advertisers, friends and well-wishers everywhere, HORTICULTURE extends the compliments of the season and heartiest good wishes that prosperity, comfort and happiness may come to them in overflowing measure during the year upon which we now enter. Let each make resolution to do his part in the advancement of our art and the uplifting of every branch of industry connected with it. Better equipment, better products, better business methods and a better market—these are objects for the attainment of

TWO NEW WHITE SEEDLING CARNATIONS.



HOUSE OF THE MARCHIONESS

The accompanying illustration is from a photograph of a house of the new white seedling carnation Marchioness, raised by L. E. Marquisee, of Syracuse, N. Y. The house was planted September 15 and the photograph taken December 9th last. That in Marchioness Mr. Marquisee has a winner, all the local florists who have closely watched it for the past three years cordially agree. The conditions under which it has been grown this season have been most unfavorable, as the government weather bureau at Syracuse University reports fewer bright days for the months of October, November and December than have been recorded in the past five years. Then, again, the greenhouses are situated in a residential section of the city and are surrounded by large dwellings. What it is capable of doing under more favorable conditions all good carnation growers can readily imagine. It is described as not a cropper, but a steady bloomer; flowers 2 1/2 to 4 inches, high built and full, with very strong clove fragrance. It requires cool treatment 48 to 50 deg. at night—a matter of great importance when the coal bill is considered. That it is a very free bloomer, the photograph clearly proves, and there is not a florist that would not be pleased to own such a crop for his Christmas trade.

The Lloyd.

The illustrations show a vase of H. A. Jahn's new white seedling carnation, The Lloyd, and also a house of this variety which originated with Mr. Jahn in New Bedford, Mass., five years ago. It is a pedigree seedling with Lawson blood in it. Mr. Jahn states that in the first year he picked from the original plant 65 blooms, and last October the cut on one day from 10,000 plants was 3,000 blooms. He says it is not a cropper but always in bloom. The flowers are pure white, very fragrant, and measure 3 inches, very often 4 inches, across; stiff stems from 18 inches to 36 inches long. The garden committee of the Massachusetts Horticultural Society who visited Mr. Jahn's greenhouses gave The Lloyd a high endorsement.

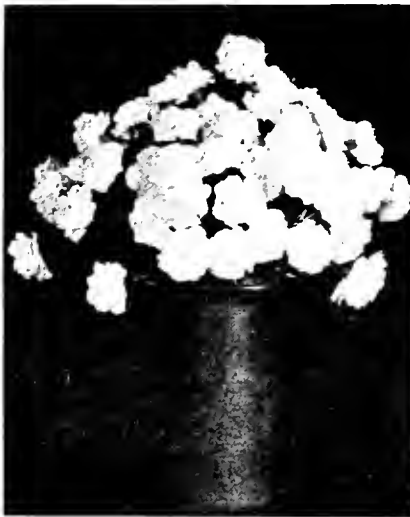

VASE OF LLOYD

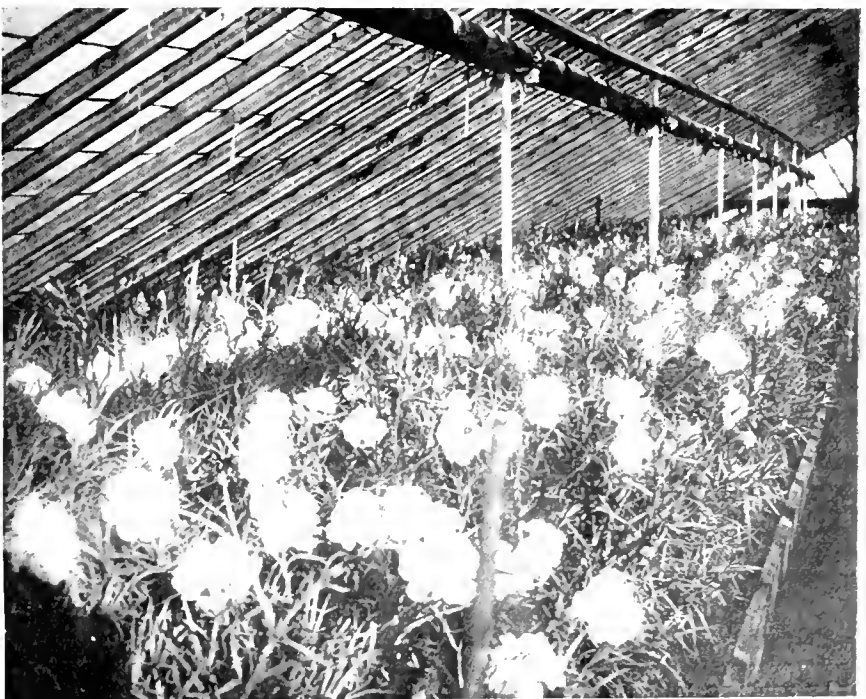

HOUSE OF LLOYD

A LETTER OF GRATITUDE.

President Thos. H. Westwood, of the Gardeners' and Florists' Club of Boston, has received a letter from the elder brother of the late John Clark, whose tragic death is recorded in our obituary columns, from which we extract the following:

"We found on our arrival in Boston that everything had been done which could be done by the neighbors and friends of the family, and as it would be impossible for us to thank each one individually, we wish you would on our behalf convey to the florists and trade generally in and around Boston, our sincere appreciation of the many kind acts and words we have received from their hands at this time.

"It is a debt of gratitude that will not be soon forgotten.

"Thanking you for your own kind words of sympathy, I remain,

"Sincerely yours,

"GEORGE D. CLARK"

AMERICAN FORESTRY ASSOCIATION.

The annual meeting of the American Forestry Association will be held in Washington, at the New Willard Hotel, on Wednesday, January 29, 1908, beginning at 10.00 o'clock A. M. On the evening of the same day a reception will be held at the residence of Mr. and Mrs. J. W. Pinchot and Mr. Gifford Pinchot, The Forester.

On arriving in Washington, members are requested to register at Room 395, Epiphany Building, 1311 G. Street, N. W.—the offices of The American Forestry Association. Programs and invitations to the reception will be issued at the time and place of registration.

NEWS OF THE CLUBS AND SOCIETIES.

NEW YORK STATE FRUIT GROWERS' ASSOCIATION.

The programme for the annual meeting of the New York State Fruit Growers' Association is considerably shorter than any previous ones, because it has been deemed advisable to have less formal addresses and more extemporaneous discussion. The meeting will be held in Syracuse January 8th and 9th in Empire Hall. The Chamber of Commerce of that city has donated several prizes for fruit exhibits. The judges will be instructed to bar all specimens showing San Jose scale.

The address of welcome will be given by Hon. Allen C. Forbes, Mayor of Syracuse, and the response by B. J. Case, of Sodus. J. R. Cornell, of Newburgh, President of the Association, will then address the meeting, after which will follow the annual reports of Secretary E. C. Gillett, of Penn Yan, and Treasurer C. H. Darrow of Geneva. There will be two addresses on the first day, one by Senator Henry M. Dunlap, on "Effect on Production of Apples Caused by Cross-Pollenizing," and one by Prof. John Craig, of Ithaca, on "Glimpses of Peach Growing in Various Parts of the United States." This will be an illustrated address. An interesting address will be that given by Prof. A. McNeill, chief of Fruit Division, Department of Agriculture, Ottawa, Canada, who will give his hearers information on the line of co-operation in the marketing of apples. It is said that Canadians have a more businesslike method in disposing of apples than have growers on this side of the border. Following this address will be one by S. A. Beach, Professor of Horticulture in the Iowa State College, at Ames, on "A Successful Organization and Its Lessons for Fruit Growers." Senator Dunlap will conclude the formal addresses with one on "Commercial Apple Growing in the Middle West."

THE AMERICAN CARNATION SOCIETY.

The rate of a fare and one-third has been again secured for the annual meeting of this society, to be held in Washington, D. C., Jan. 28, 29, 30. This is on the certificate plan; all you have to do is to be on hand about fifteen or twenty minutes before your train is due, ask the agent for a certificate for the meeting of the American Carnation Society, pay full fare going and you can then return for one-third of a full fare. As the two-cent rate is in effect in quite a number of states this will make a very cheap rate for this meeting and no carnation grower who consults his own interests can afford to miss it. Premium lists have been mailed to all of the members. Anyone who wishes a copy can obtain one by applying to the secretary.

ALBERT M. HERR,
Lancaster, Pa.

CONNECTICUT HORTICULTURAL SOCIETY.

The annual meeting of this society was held in Hartford on Friday, December 27. President Sternberg in the chair. The general purpose of this meeting was the election of officers for 1908. There was an extra large attendance of members, nearly a hundred being present. Following is a list of the officers who will guide the affairs of the society during the ensuing year: President, J. F. Huss; treasurer, W. W. Hunt; secretary, Alex. Cumming, Jr. The latter has been in the employ of the Parks Department for several years, and is a son of the retiring secretary. As shown by the reports of the treasurer and secretary, the financial condition of the society is excellent, and a brief resume of the business of the past year proved that our organization did much creditable work in the interests of horticulture.



PRESIDENT J. F. HUSS.

President-elect Huss outlined the work the society should undertake during the coming year. He intimated that various committees would be appointed, and that the flower shows to be held under the auspices of the society would be on a larger and more elaborate scale than they had been for several years. Papers on interesting horticultural topics would be read at all the meetings, and altogether a campaign of useful activity would be inaugurated.

President Sternberg feelingly referred to the bereavement recently suffered by President-elect Huss in the death of his estimable wife, and an engrossed resolution of sympathy and condolence was sent to Mr. Huss and his family in the name of the society.

DETROIT FLORISTS' CLUB.

President E. A. Scribner's selection of six members to decide whether there should be a spring or a fall flower show, or both, has fallen on E. S. Beard, Thos. Brown, Robt. Kage, Albert Pochelon, Bruno Schroeter and J. F. Sullivan.

Mr. Wm. Heilscher, our hustling and inventive wire-worker, is distributing a very handsome calendar.

TRI-CITY FLORISTS' ASSOCIATION.

The subjects which will be considered in papers and discussions at each monthly meeting of this association are as follows:

January: "General discussion of heating and building greenhouses."

February: "Propagation of Easter stock, such as lilies, hydrangeas, lilacs, and azaleas, etc."

March: "How, when and what are the best varieties of bedding plants for spring sales."

April: "Planting of shrubs and hardy plants, also, the best and most useful varieties."

May: "What are the most profitable and salable plants and cut flowers for Decoration Day?"

June: "Soils: How to prepare the best soil for roses, carnations, violets, mums and general bedding plants."

July: "The ladies' month; preparing of floral work and what are the best out-of-door plants to grow for funeral work."

August: "How to handle cold storage lilies and valley pips."

September: "When to plant bulbs for early and late flowering, and what are the best varieties for that purpose?"

October: "Poinsettias. Best varieties of azaleas for Xmas; are geraniums profitable for Christmas?"

November: "Out-door planting of bulbs, and what are the best varieties for show beds?"

December: "Propagation of roses, carnations, bedding plants, also sowing of seeds."

The committee which reported on the above subjects for the coming year's discussions is composed of Frank Woelz, Henry Gaethje of Rock Island, John T. Temple and H. M. Bills of Davenport, and Alfred Anderson of Moline, Ia.

NEWPORT HORTICULTURAL SOCIETY.

The regular meeting of this society was held December 24. President John T. Allan in the chair. The ball committee reported very satisfactory progress, and the newly elected financial secretary, D. J. Coughlin, reported surprising success in the collection of dues since assuming the office. He had to the credit of the society nearly \$100 in the bank, being very good work in two weeks. It is seldom Alex. MacLellan is absent from a meeting but a slight illness detained him this week. He has since entirely recovered. The new president, John T. Allan, has evidently started in with the determination to make his administration a success, which, however, is only possible when aided by all hands interested. The executive committee organized the same evening, electing John T. Allan chairman and David McIntosh secretary. D. M.

SOCIETY OF AMERICAN FLORISTS AND ORNAMENTAL HORTICULTURISTS.

To the members of the S. A. F. and O. H.

Greetings: On the opening of this new year, I desire on taking over the office of President of our national society, to extend to you my heartiest good wishes for a prosperous and successful year, both as regards our individual interests and those of the organization, the welfare and advancement of which we all have so much at heart. No man ever entered on the duties of the presidency of the S. A. F. and O. H. more conscious of the great responsibilities resting upon him than I do. To maintain the standard of efficiency to which the organization has been brought by my able predecessors is a task which even those most experienced in the work of the society must regard as a formidable one. But as the old saying has it, "The best of men are but men at best," I assume the leadership to which your suffrage elected me, promising you my very best endeavor to fulfil as far as I faithfully and possibly can, the trust, which you, my fellow members, have reposed in me.

But in order that the society shall measure up to its highest efficiency during the year 1908, I must have and expect to obtain, the fullest cooperation of all the members. I therefore urge the state vice-presidents to do their very best in securing new members in their respective localities, to spread abroad therein propaganda concerning the organization, its benefits, its usefulness, and how deserving of encouragement and support it is, by every man and woman engaged in lines of industry we are banded together to promote and advance.

Of the various committees appointed by my predecessor in office, I earnestly desire, as I feel sure of obtaining, the faithful and full performance of their respective duties which have been assigned to them, as on the result of their endeavors very much of the progress of our association depends. I also hope that every member, individually, will do his or her part in the furtherance of the work of the S. A. F. and O. H. "One for all, and all for one" should be the motto impelling each of us in our every effort along the lines of society work.

I wish to call particular attention to the forthcoming flower show to be held under the society auspices at Chicago, Ill., in the fall of this year. The committee appointed to carry out the detail of this our first undertaking in this line are now hard at work, and I bespeak for them the best assistance of all the members, looking to the ultimate success that is hoped for in our stupendous venture.

I would briefly refer to the great loss which our organization has sustained by the sad death of our secretary, P. J. Hauswirth. The work of the secre-

tary's office is being looked after by Mr. Willis N. Rudd, Morgan Park, Ill., whose well-known ability ensures the utmost efficiency in everything connected with that office.

The preparation of the annual report for 1907 is being rapidly pushed to a conclusion, and the publication and distribution of the document will be accomplished with as little delay as possible.

Again assuring you of the best that is in me, in the conduct of the society's affairs during 1908, and looking for, and expecting the cordial and hearty support of you all, I am,

Yours fraternally,

F. H. TRAEENDLY,
President S. A. F. and O. H.

President F. H. Traendly announces that he has appointed Messrs. John Young, of New York, and George Asmus, of Chicago, to serve as directors of the society for the term of three



W. N. RUDD

The New Secretary Society of American Florists and Ornamental Horticulturists.

years, beginning January 1, 1908. John Young is the well known wholesale florist of New York city. Mr. Young has served for many years as secretary of the New York Florists' Club, where he has won popularity by his faithful attention to the duties of his office and where the experience gained in club work has thoroughly equipped him for good service on the executive board of the National Society. George Asmus is manager of the Schiller retail flower establishment in Chicago. He is an enthusiastic worker in the exhibitions and other enterprises of the Chicago horticultural organizations and has also done good service in various capacities connected with the S. A. F., especially on the spotting features of the annual

conventions. He is an estimable representative of the younger element in the society and will make a good and earnest executive officer.

AMERICAN ROSE SOCIETY.

The commendations received by the secretary of the American Rose Society from the life members of the society who have received their certificates, show that these very handsome parchments are highly appreciated.

The Chicago exhibition of the American Rose Society will open on the fourth Wednesday in Lent, that is, the 25th day of March, and will run three days. The Chicago Florists' Club advises that the show will be held at Marshall Field's or at the Auditorium. The Rose Society has about ready for mailing the schedule of prizes. In Division F, the special prizes are thrown open for support from all America that has a good word or wish for roses.

There will be some fine papers offered at the annual meeting.

BENJAMIN HAMMOND, Sec'y.

TARRYTOWN HORTICULTURAL SOCIETY.

The regular monthly meeting of the Tarrytown Horticultural Society was held on Thursday evening, December 26, Mr. Frank R. Pierson presiding. James Bell and Hector McDoudd were elected active members. The following officers were elected: President, Robt. Angus; vice-president, Abel Weeks; secretary, E. W. Neubrand; corresponding secretary, L. A. Martin; treasurer, James T. Lawrie. James Ballantyne very ably opened a discussion on roses under glass, after which many of the members took active part. The annual dinner will be held at the Florence Hotel on the evening of January 15th. DAVID MacFARLANE.

CLUB AND SOCIETY NOTES.

The annual ball of the Newport Horticultural Society will take place January 8.

The lecture course conducted by the American Institute of the City of New York opens on January 8 in Berkeley Lyceum. George T. Powell speaks on "Agriculture as a Business and a Profession."

The Western Association of Nurserymen at their meeting in Kansas City, Mo., December 17 and 18, elected officers for the coming year as follows: President, E. P. Bernardin; vice-president, E. S. Welch; secretary, A. J. Holman, Leavenworth.

The committee on gardens of the Massachusetts Horticultural Society have awarded prizes as follows: The J. H. Hunnewell Triennial premium to the Morton F. Plant Estate, Groton, Conn., T. W. Head, gardener; special prize for best kept estate of from one to three acres to Hon. J. R. Leeson, Newton Centre, Mass., Jas. Cartwright, gardener; silver medal to James Garthley, gardener to H. H. Rogers, Fairhaven, for skillful cultivation of chrysanthemums; first prize for peony garden, to Dr. Minot, Milton; first prize for vegetable garden non-commercial, of 20,000 feet, to P. P. Baugs, Ayer, Mass.

Seed Trade

In this the first issue of HORTICULTURE for 1908, congratulations are extended to the American Seed Trade on the excellent position in which it now stands. Despite the money stringency, talk of panics, and a general plowing down of business activity, there appears no cloud of serious proportions on the seedmen's horizon. Excepting beans, most staples in the seed line are in short supply, and active demand at prices far above normal, and unless all indications are misleading, stocks in most lines will be greatly reduced or altogether cleaned out, and on the general shortage more actual profit will be made than on a full crop.

One class of our citizens seem scarcely to have known of any business depression, and that is the farmers. While staple farm crops have not been quite so large as those of 1906, according to Bradstreet's, they are worth 20 per cent. more, or over \$200,000,000 over the bumper crops of 1906. So long as the farmers are prosperous and have money to spend, there is no danger of any prolonged business depression, and as the seedmen's prosperity is largely dependent on the farmers, the present outlook is about as good as could be desired. During the panic of 1893-4 the farmers were not in the happy condition they are today. Then, they were groaning under debts, and farm products were selling at almost the lowest prices in half a century. The gold supply was inadequate, and the per capita circulation fully one-third less than at present. Let every one take an optimistic view of the future, and this confidence will of itself be a most important factor in restoring prosperity.

New bids have been asked for by the department of agriculture for spot seeds to be used in the present distribution, which seems to indicate that some persons have disappointed "Uncle Jimmie." Learning where some of the orders had gone last fall, it was hinted in HORTICULTURE at the time that the present situation was likely to develop. The absurd policy of buying only of the lowest bidder regardless of the standing of the concern, or their ability to deliver the goods, has long been a scandal to the department, and caused a general overturning only a few years ago at the time of the Nellis regime. Those upon whom the secretary has placed the responsibility of ordering the seeds and other items required by the department in that connection, know all about the scandals of a few years ago, and were largely instrumental in exposing the frauds being perpetrated on the Government, resulting from the ridiculous practice of recognizing only the lowest bid regardless of its source. Yet the same policy is being followed now by the same men, and inevitably with the same results. Early in November it was authoritatively stated that the department had placed orders covering all requirements in seeds, and now comes a fresh call for bids. Why? Simply because some one has failed to "make good" whose bid was too temptingly low for the department officials to pass. Everything required could have been secured from responsible

houses at very reasonable figures, but as the department will buy only at auction prices, these figures were too high. However, it looks as if in the final wind-up they would have to pay the prices or go without the goods. "Hence these tears."

Congress was very prompt in passing the supplementary appropriation of \$50,000 asked for by Sec. Wilson, and his credit need not now be doubted. This at least is satisfactory.

Mr. O. K. Natt has severed his connection with Josiah Young of Troy, N. Y., and is now open to accept a position. Mr. Natt is especially valuable to any one conducting an experimental farm or trial grounds, but can fill any position in a seed house, wholesale or retail.

The stock of Jos. A. Schindler Seed Co., New Orleans, was badly damaged by fire and water on December 15.

POPULARITY OF THE SWEET PEA.

The sales of the "Sweet Pea Annual" for 1907 amounted to about £21, as compared with £15 17s. in 1906. This is substantial evidence of the increasing interest that is taken in the society's official publication. The "Annual" for 1908 is being prepared by Mr. Chas. H. Curtis and Mr. Horace J. Wright, who report that the forthcoming issue will lack nothing in interest and usefulness when compared with previous efforts. A few of the items will be "More Historical Notes," by Mr. S. B. Dicks; "Popular Voting on Novelties," by Mr. G. H. Mackereth; "Sweet Peas in Devon," by Mr. R. Bathurst; "Wire Netting for Sweet Peas," by Mr. G. H. Leak; "Breakers Ahead," by Mr. Walter P. Wright; "Adherence to Principles," by Mr. George Gordon, V. H. M.; Medallists for 1907; The Audit for 1907; the Classification for 1907; report of the floral committee; list of officers, members and affiliated societies, and a complete list of all known sweet peas, prepared by Miss Jessie Cuthbertson.—Journal of Horticulture (England), December 19, 1907.

LIST OF PATENTS.

Issued December 24, 1907.

- 874,534. Wheel Plow. William H. Parlin, Canton, Ill., assignor to Parlin & Orendorf Co., Canton, Ill., a Corporation of Illinois.
- 874,566. Wheel Cultivator. Arthur F. Brown, Springfield, Ohio, assignor to P. P. Mast and Company, Springfield, Ohio, a Corporation of Ohio.
- 874,597. Plow. Edwin Jarrell, Riverdale, Kans.
- 874,776. Manure Loader. Henry J. Lawrence, Elmore, Minn., assignor of one-half to Oscar E. Seastrom, Elmore, Minn.
- 874,800. Beet Harvester. Edwin E. Shaw, Edgewood, Mich.
- 874,827. Check Row and Hill Marker. Winfield J. Botts, Havre de Grace, Md.

We learn that Suburban Life has been sold to McClure's.

ASPARAGUS ROOTS FOR FORCING

Each root will cover more than the top of a basket and is five years old. Will make excellent clumps for forcing. Only \$2.50 per 100 if ordered at once.
Rhubarb Roots for Forcing. Fine large roots for \$6.00 per 100. Will produce excellent results.
Asparagus Seed of an immense variety. This variety comes from the Palmetto but is twice as large. Seven to ten stalks in a bunch. Twenty dollars per pound. Only a limited quantity.

WARREN SHINN,

Woodstown, N. J.

STATEMENT OF PLANT IMPORTS.

There were entered at the port of New York during the two weeks Dec. 18 to Dec. 31, 1907, the following plants, etc:

From Rotterdam: H. F. Darrow, 4 cs. plants; W. Elliott & Sons, 1 cs. do.; P. Onwerkerk, 4 cs. trees; Sundry Forwarders, 34 cs. plants, 16 cs. trees, 1 cs. bulbs, 39 cs. roots.

From Antwerp: Stump & Walter Co., 4 cs. bulbs; Vaughan's Seed Store, 9 cs. do.

From Germany: H. F. Darrow, 60 cs. lily of the valley; W. Hagemann & Co., 362 cs. do.; C. F. Meyer, 158 cs. do.; S. Stern, 222 cs. do.; J. M. Thorburn & Co., 1 cs. seeds; To order, 1 cs. plants.

Via Havre: H. F. Darrow, 282 pgs. seeds; J. M. Thorburn & Co., 16 pgs. do.; Vaughan's Seed Store, 100 pgs. do.; Forwarders, 14 pgs. do.

From Copenhagen: Yokohama Nursery Co., 36 cs. garden seed.

From London: W. R. Huntington, 44 bls. garden seed; 22 bags do.

Via Southampton: C. C. Abel & Co., 27 cs. plants; H. F. Darrow, 170 pgs. seed; McLutchison & Co., 104 pgs. plants; August Rolker & Sons, 22 pgs. do.; J. M. Thorburn & Co., 35 bags garden seed; Weeber & Don, 3 sacks seed; Forwarders, 1 cs. trees.

From Glasgow: H. F. Darrow, 15 cs. trees.

INCORPORATED.

Norris F. Comley Conservatories, Lexington, Mass.; N. F. Comley, T. B. Hughes, A. E. Goldberg; capital, \$15,000.

Buffalo Cut Flower Co., Buffalo, N. Y.; J. H. Gould, L. H. Gould, G. R. Sheldon, Middleport, N. Y.; capital, \$25,000.

International Seed and Bulb Supply Company, Boston and Philadelphia; A. A. Holmes, Edna M. Holmes, Edith V. Henderson; capital, \$50,000.



HYACINTHS, TULIPS, NARCISSI
 AND OTHER BULBS
ROMAN HYACINTHS and the true
PAPER WHITE GRANDIFLORA

Ask for our Wholesale Trade List at Hillsgom
K. VELTHUYS, Hillegom, Holland
 Rep. by **FELIX BOSCH, 260 Clarendon St., Boston**

A NEW FIRM.

Thomas Knight and Geo. F. Struck, heretofore traveling representatives for well-known firms, announce that they have joined interests and on and after January 1, 1908, will be in business as Knight & Struck at Room 8082 Metropolitan Building, New York, as jobbers in palms, bay trees, evergreens, shrubs, and bulbs. Both these young men are enterprising and deservedly popular, and they have our best wishes for a bright and prosperous business career.

**Cover your Cold Frames with
HOT BED MATS**

Made of burlaps, thickly quilted with jute making a serviceable warm mat. 76 x 76 inches, will cover two frames.

\$1.25 each. \$14.00 per doz.

WM. ELLIOTT & SONS

201 Fulton St., NEW YORK.

SEEDS — NEW STOCK

	Trade Pkt.	Per Oz.
Begonia Vernon	.50c	\$2.00
Begonia Erfordii	.50	
Candytuft Empress		.15
Carnation Marguerite	.25	1.00
Centau ea Gymnocarpa	.10	.25
Cyclamen Giganteum in colors, per 1000 seeds		\$4.00
Lobelia Crystal Palace Comp.	.25	1.25
Lignonette New York Market	.50	5.00
Lysotis Victoria	.10	.50
Salvia Splendens Grandiflora	.25	1.00
Salvia Splendens Bonfire	.50	2.50
Stock Boston Market in colors	.50	5.00
Verbena Mammoth mixed	.25	1.00
Vinca Rosca and Alba	.10	.40

W. E. MARSHALL & CO.

145 West 23rd Street, - - New York

WIBOLTT'S SNOWBALL CAULIFLOWER-SEED
No. 34
is the earliest of all Snowballs, the most compact, the surest headed, is giving the largest and snow-whitest heads, and is the best keeper in dry-weather. Demand it through your seed-firm or direct from
R. WIBOLTT, NAKSKOV, DENMARK

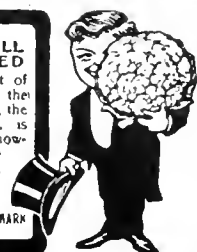

Cyclamen

Superb English Strain
Second to none in size of flowers
Giant Crimson.
" Pink
" White.
" White with Claret base.
" Mauve.
" Salmon Queen.
" New Fringed.



100 seeds \$1; 1000 seeds \$9.

H. E. FISKE SEED CO.

12 and 13 Fanueil Hall Square, - BOSTON, MASS.

CAULIFLOWERS & CABBAGE SEED

HJALMAR HARTMANN & CO.,
12 Stormgade, COPENHAGEN, DENMARK.

ESTABLISHED 1802



PER 1000 SEEDS

Asparagus plumosus nanus seeds \$2.25

Asparagus plumosus robustus seeds 2.50

Send for our Wholesale Catalogue of Seeds for Florists and Market Gardeners, ready in a few days.

J. M. THORBURN & CO.

33 Barclay St., through to 38 Park Place

NEW YORK

Everything of the Highest Grade

"QUALITY IS REMEMBERED LONG AFTER PRICE IS FORGOTTEN."

WHAT QUALITY MEANS.

Quality means the best and finest types procurable in their respective classes. We go to specialists for our flower seeds. Our customers, the Florist, the private gardener demand the highest grade. We have no cheap catalogue trade. "Quality" may mean a little higher in price. "Quality" in fact means "Quality" and we know that when you buy from us you get it—and our customers know it too. Catalogue now in press; 40 pages. Write for one its FREE. We sell bulbs too.

ARTHUR T BODDINGTON, SEEDSMEN

342 West 14th St., - - NEW YORK.

BRASLAN SEED GROWERS CO.

GROWERS FOR THE

WHOLESALE TRADE ONLY

SAN JOSE, - - CALIFORNIA

Burpee's Seeds

PHILADELPHIA

Blue List of Wholesale Prices mailed only to those who plant for profit

Lily of the Valley

Finest Berlin \$12.00 per 1,000

BRIDGEMAN'S SEED WAREHOUSE

RICKARDS BROS.

Props.

37 East 19th St., - NEW YORK CITY

C. G. MORSE & CO.

Address all communications to our permanent address
48 to 56 Jackson St., San Francisco, Cal.

The Largest Seed Growers in the United States

BAMBOO CANES

TOUGH AND STRONG
6 ft. long — \$1 per 100; \$6 per 1000; \$11 per 2000

They cost about 10 per cent. more than other kinds, and they are 10 times better.

STUMPP & WALTER CO., - 50 Barclay St., New York

**RELIABLE SEEDS
SOW NOW**

	Tr. Pkt.	6 Tr. Pkts.
Alyssum Carpet Queen real dwarf for pots only, no equal.	\$.25	\$1.25
Begonia Gracilis Luminosa, new	.50	2.50
Erfordia, beautiful.	.50	2.50
Zangen's Bedding Queen	.50	2.50
Lobelia, new Trailing Hamburgia	.30	1.50
Petunia, Zangen's Extra Double		
Fringed Giants.	1.00	5.00
Zangen's Superb Single		
Fringed Giants.	.75	4.00
Zangen's Ruffled Giants, the best.	1.00	5.00
Phlox, best for pots, Fireball, Roseball, Snowball, each color.	.25	1.25
Salvia Fireball, new, a fine potter	.50	2.50
Stocks, German 10 weeks: Blood-red, Lavender, Pink, Purple, White, each color.	.50	2.50
Verbena Mammoth: Pink, Purple, Scarlet, Striped, White, each color.	.25	1.25

My New Fall List Ready for the Asking

O. V. ZANCEN

Seedsman. HOBOK, N. J.

Best Quality Fall Bulbs

It is to your advantage to place your order early. Send us a list of your wants and we will quote you rock-bottom prices. Copy of our Florists' Bulb Catalogue will be sent upon request. Catalogues now ready.

VICK'S SUPERB PANSY SEED

All the best varieties in separate colors

VICK'S SUPERB MIXTURE

the best strain from all the leading named sorts

1-8 oz. 75c. 1-4 oz. \$1.50 Ounce \$5.00

JAMES VICK'S SONS, Rochester, N. Y.

CYCLAMEN

Farquhar's Giant Strain

Unsurpassed for size of flowers.

Giant Crimson Giant Pink
Giant White Finest Mixed
Giant Excelsior, White with Claret Base

100 seeds, \$1.25; 1000 seeds, \$10.00.

R. & J. FARQUHAR & CO.

6 & 7 So. Market St., Boston, Mass.

BULBS

SPIREA JAPONICA COMPACTA MULTIFLORA, FL. RIBUNDA, GLADSTONE

Get our special prices on surplus Bulb stock.

Joseph Breck & Sons Corp.
47-54 NO. MARKET ST., BOSTON, MASS.

JUST ARRIVED

LARGE SHIPMENT OF High-Grade SCOTCH SOOT.

We have the Stott Double Nozzle
THOMAS J. GREY CO.

32 & 33 So. Market St., BOSTON

Obituary

George Wainwright.

George Wainwright, nurseryman and florist of Trenton, N. J., whose death occurred early on the 31st December, 1907, and whom you spoke of in your last issue as having undergone an operation for cataract, which had rendered him helpless for three or four years, was my dearest friend, and the bravest, most honest and simple-minded man I ever knew.

Wainwright came of an excellent old Yorkshire family, several of whom made most enviable reputations for themselves. Henry, a younger brother, was mayor of Doncaster for several successive terms, and when he died as alderman, Doncaster suspended all business for his funeral. An uncle, John Wainwright, was quite an historian, having written several histories of the Yorkshire Wapentakes, and a brochure on the "landing of Julius Caesar in England."

George Wainwright was 82 years old on the 14th February last, when the writer and a few of his old friends gave him a surprise party. During last summer he felt he must discontinue business, and sold his nursery grounds on Princeton avenue; soon afterwards he underwent the operation for his sight, which resulted in its partial restoration, but was of course a shock to a man of his age.

On Christmas Day I dined with his family, and Wainwright indulged me with one of his characteristic arguments on evolution. After dinner he seemed exhausted, laid down on a couch, and soon to bed. On the morning of the 30th early he arose for a drink of water, stumbled, fell, severely hurt and shocked himself, and never recovered but for a few moments' recognition of myself and one or two of his family.

Wainwright learned his business in this country with the late Robert Buist of Philadelphia, serving him in company with the late Thomas Meehan. He then came to Trenton and about 1854 bought 100 acres of land where the Fashion Farm is now, and for a short time he conducted a farm there. He eventually decided to establish a nursery for himself, and in 1857 he bought the Wainwright Nurseries at Princeton and Ingham avenue. This tract he cultivated until last July, when he sold the property to Harrisburg parties and retired to private life.

He was fond of roses, and raised several fine hybrids. The "Dinsmore" was one of his, and was brought to the notice of the late Peter Henderson by the writer through an article in *The Country Gentleman*, describing its perpetual blooming. It is not so fine a grower on the Atlantic as on parts of the Pacific coast, however, but Henderson bought it, in company with John Henderson of Flushing, and changed its name from the "Pocahontas" — Wainwright's name. On his old grounds there is one of the finest male trees of *Ginkgo biloba* in the country.

For many years past Wainwright made a sowing of seeds of *Magnolia Lenzelii*, of which he had a fine speci-

men, and as you know, this was claimed to be a hybrid. My friend and I watched those seedlings with great interest, and some were very remarkable. Some had golden foliage, one was dark inside and out, far darker than the darkest *atropurpureas* or *nigras* I have seen. But there was no trace of the tree form among them, and I feel sure that all the so-called hybrids of bush form are nothing but *obovatas*.

Mr. Wainwright was liberal, kindly, honest, a good father, a warm friend and a grand Englishman.

Requiescat in pace. J. MacP.

John Clark.

A terrible calamity, one of the saddest events of the holiday season, was the tragic death of John Clark, aged 42, his wife Fanny, 35, and their three children, John Clark, Jr., 11 years, Philip, 7 years and Doris, 4 years, all of whom perished in a fire which destroyed their home at Watertown, Mass., early on the morning of December 27.

John Clark was a salesman for the H. E. Fiske Seed Company, of Boston. His father John F. Clark is em-

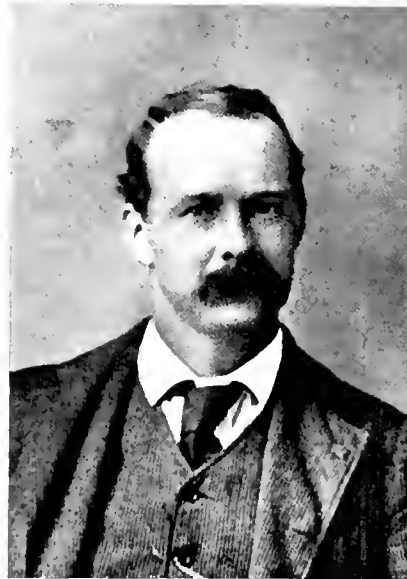

JOHN CLARK

ployed at the Botanic Garden in Washington, one brother is engaged in the florist business in Washington, and two other brothers, George and James are in the employ of H. A. Dreer, Philadelphia. Mr. Clark has been in the seed business from his youth up. He had been with Peter Henderson & Co., New York, Joseph Brock & Sons, Thos. J. Grey & Co., and W. W. Rawson & Co., Boston, previous to engaging with the Fiske Company. He was widely known and the calamity has cast a gloom over the seed and florist trade circles about Boston, where he was a member of the Massachusetts Horticultural Society and the Gardeners' and Florists' Club. The cause of the fire is a mystery. Neighbors discovered the blaze about 1 A. M. and sent in an alarm, but the firemen were absent on another call and there was some delay. The bodies of Mr. Clark and the two boys were found in the hall at the head of the stairs, death having come from suffocation. The mother and lit-

tle girl could not be reached until after the fire had been extinguished and their bodies were badly burned. The date was the eleventh birthday of the eldest boy. All were buried in one grave in Ridgelawn Cemetery. The funeral services were held in the open air in the presence of about two thousand people. Many beautiful floral offerings from the seed trade, the Florists' Club and other organizations and individuals, testified to the respect and sorrow of Mr. Clark's associates.

Reuben H. Warder.

Reuben H. Warder, secretary of the Lincoln Park Board and superintendent of the park for the last six and one-half years, died on December 26, at his home, 50 St. James place, Chicago, after an illness of two days. He was 64 years old.

Mr. Warder, who was born in Cincinnati, relinquished his position as superintendent of the park in his native city to come to Chicago in June, 1901. At that time he was known as a skilled horticulturist, and his coming to this city at the solicitation of the Lincoln Park board was for the purpose of rehabilitating the North Side parks. This work has been accomplished under his direction, and the members of the board refer to his efforts in high terms of praise. Mr. Warder's father, J. A. Warder, was one of the distinguished horticulturists of his time, belonging to most of the societies interested in that work, and he took an active part in the formation of organizations calculated to spread the study of this particular branch. The junior Mr. Warder took a deep interest in the reconstruction of Lincoln Park, and all of the innovations are along lines suggested by him. Board members were impressed with the deep study which he gave to his work. The body was taken to Cincinnati for burial there.

Myrtle Rosenfield.

J. F. Rosenfield, peony specialist of West Point, Nebr., has been greatly afflicted in the loss of his charming and gifted daughter Myrtle, aged 29 years, who died December 16th.

The following is from the local press.

"Accomplished in music, a pure and spotless character, a cordial greeting for everyone, kindness personified in her being for father, sisters and brothers, the light of their home, one of the most welcome callers in any of our homes, a favorite among the young people, this young lady was on earth long enough to leave every life with whom she came in contact better, and the good seeds sown will multiply a thousandfold in their fruitage during the years to come."

Service was held at the home and also at the Congregational Church, the post pastor, Rev. Crofts, of national reputation, officiating. Some years ago Mrs. Rosenfield died, leaving eight children; then Myrtle took charge of the home. The great loss falls heavily on the family. C. S. HARRISON.

Walter White.

Walter White, one of the oldest flower growers in Philadelphia, died at the Old Men's Home December 26,

at an advanced age. Mr. White started the year before Dreer did (which we understand was in 1836) and continued actively in business until a few years ago, in West Philadelphia. His location, latterly, was at 36th and Chestnut. He was a very honest, hard-working man, but did not have the gift of gathering riches, but through the efforts of friends, chief of whom may be mentioned Robert Craig, he passed his last years comfortably in the Old Men's Home. He came originally from Ireland along with two brothers, all three being now gone and no family left behind. One brother ran the retail flower store on North 8th street for many years; this establishment being still in existence under the title of White Bros.

Francis Quinlan.

Francis Quinlan, a prominent florist of Lynn, Mass., died at his home on December 28, aged 48. For many years Mr. Quinlan was connected with the firm of E. & J. Bowditch, landscape gardeners of Boston, and laid out some of the largest estates in this country. Twenty years ago he started in business in Salem but later moved to Lynn, where he has conducted a large florist business. He was prominently connected with many fraternal organizations.

Arthur B. Howard.

Arthur B. Howard, who was born in Belchertown, Mass., June 1, 1833, and lived there all his life, died at his home on December 20. Mr. Howard was an enthusiast in everything pertaining to flowers or fruit, and held an enviable reputation as a horticulturist and pomologist. He has been a successful exhibitor both in his own and other states. His petunias have long been widely known. Two children survive.

Everett B. Clark.

The death of Mr. Everett B. Clark, of Milford, Conn., will be sincerely mourned by practically the entire seed trade of the United States and Canada. He leaves a record for uprightness and fair dealing which his successors will do well to imitate. For want of time further references to Mr. Clark will be left for a future issue.

Mrs. W. H. Gunther.

Mrs. W. H. Gunther of New York City passed away on Christmas eve. Funeral services were held on the evening of December 26.

Mrs. Julius E. Schray.

Mrs. Julius E. Schray, of St. Louis, died on December 23 and was buried on Christmas day.

NEP. WHITMANI
2 1/4 in., \$5.00 per 100
NEP. WHITMANI
3 1/2 in., \$25.00 per 100
BOSTON FERNS
2 1/4 in., \$3.00 per 100
H. H. BARROWS & SON Whitman, Mass.

"TO THE TRADE"

On and after JANUARY 1, 1908, all Rights and Titles of the Firm of
NATHAN SMITH & SON, Adrian, Mich.
Will be transferred to, and thereafter the Business will be Conducted under the firm name of
ELMER SMITH & CO.

To Whom All Accounts Due the Old Firm are Payable. The new firm will discontinue many lines formerly handled, and as soon as stock on hand can be disposed of, will offer to the trade
Chrysanthemums and Aster Seeds Only
devoting their entire time and energy to the development and improvement of these two popular florists' flowers. Your trade solicited and will receive the same prompt and careful attention as in the past. CATALOG EARLY IN JANUARY.

GERANIUMS

NEW VARIETIES.—In New Varieties we make a special offer of one each of 100 varieties 1905 and 1906 introductions for \$1.00. This is acknowledged to be the finest collection ever offered in this country, coming as it does from such noted introducers as Bruant, Lemome, Bouchlat and Cannell, is in force enough that in it will be found represented the highest state of development in Geraniums at the present time. Some of wondrous beauty in solid colors, others of exquisite combination of colors which baffles successful description, and would make grand acquisitions to any collection, possessing as they do special merit of such sterling qualities that we are satisfied they are destined to become the standards in their several different classes.

STANDARD VARIETIES.—In standard varieties we offer an immense stock in prime condition, for immediate shipment, at from \$2.00 to \$4.00 per 100. For \$18.50 we will send one thousand, 50 each of 20 varieties, our selection, single and double, all "A No. 1" kinds.

PELARGONIUMS.—In a good assortment, containing such kinds as GALATEA, COUNTESS OF CREW, PURITY, COUNTESS OF WARWICK, GLORIOSA, TOMMY DODD, &c. \$1.50 per doz. \$6.00 per 100.

Lantanas, in 10 good varieties.....	Per 100	\$2.00	Alyssum, Giant double	Per 100	\$2.00
Hardy English Ivy,	2.00		Coleus, 10 good varieties	2.00	
Fuchsias, Black Prince	2.00		Ageratum, Stella Gurney, Inimitable		
Hellebore, good assortment.....	2.00		dwarf white.....	2.00	

Cash with order.

R. VINCENT JR. & SONS CO., White Marsh, Md.

ORCHIDS
Largest Importers, Exporters, Growers and Hybridists in the World
Sander, St. Albans, England
and 235 Broadway, Room 1
NEW YORK CITY

... ORCHIDS ...
Just to hand, C. Trianae, C. labiata, C. Mossiae, C. Intermedia, C. Schroderae, C. Speciosissima, C. Citrina, C. Gaskelliana, Laelia Aneaps, L. Albida, L. majalis, L. Autumnalis, Epidendrum Vittelium majus, E. Cooperianum, Oocidium Crispum, O. Varicosum, O. Cavendishianum, O. Luridum, Odonto. Citrosimum. To arrive in a short time, C. Dowiana, C. Aurea, C. Warnerii, Miltonia Vexillaria.
CARRILLO & BALDWIN SECAUCUS, N. J.

ORCHIDS
Just arrived, in fine condition,
Cattleya Trianae (new district).
Oncidium Varicosum Rogersii.
Write for prices.
JOSEPH A. MANDA, 191 Valley Road,
WEST ORANGE, N. J.

LILIUM AURATUM
9-11 \$75 per 1000
ROSEUM and RUBRUM
9-11 \$65 per 1000
MULTIFLORUM
7-9 \$45 per 1000
D. RUSCINI, 128 West 6th St., CINCINNATI, OHIO

THE FINEST
Lily of the Valley Excellenta
From cold storage. Only few cases left. Please order at once. \$32.00 per case of 2000 fine pips.
JOHN SCHEEPERS & CO.
4 & 6 Old Slip, - - NEW YORK.

Write at once for our quotations on all
ORCHID IMPORTATIONS
FOR 1908 DELIVERY
JULIUS ROEHRS CO.,
The Orchid Nurseries, Rutherford, N. J.

ORCHIDS
We are at present booking orders for freshly imported Orchids for delivery 1908, of all leading kinds at reduced prices. We have just received the following:—
Oncidium, Sarcodes, O. Forbesu, O. Tigrinum and Sophronites, Grandiflora and Coccinea.
LAGER & HURRELL, Summit, N. J.

ORCHIDS
The largest importation of Orchids ever received in this country WILL ARRIVE next spring from Brazil, Colombia and Venezuela. If you intend putting in stock wait for these to arrive and we will quote the Lowest Prices in America.
ORDONEZ BROS., - Madison, N. J.

JOHN SCOTT
Grower of PALMS, FERNS and Other Decorative Stock
NEPHROLEPIS SCOTTII All the Year Round
Rutland Road and East 45th St.
Telephone 2890 Bedford **BROOKLYN, N. Y.**

JAPANESE
THE YOKOHAMA NURSERY CO. LILIES
31 BARCLAY STR. NEW YORK. PLANTS
BAMBOO STAKES

Prices Quoted in these Columns are for Dealers Only. When Writing to Advertisers Please Mention HORTICULTURE.

PHILADELPHIA NOTES.

Frank W. Whiteley, late of Coles & Whiteley, Lansdowne, is now located with the Allen Piano Co. at 1715 Chestnut street.

The dance and reception given by James W. Paul in honor of his daughter at Horticultural Hall, December 26, was one of the most elaborately decorated affairs ever held in Philadelphia, and reflected great credit on the artists, J. J. Habermehl's Sons. The Benedicts' ball at the same place December 27 was also an important function, being handled in the decorative time by Graham Blessings on the good spenders. A tremendous lot of flowering and foliage plants found appreciative use in these events, and incidentally made profit and fame for the business. The object being to enable

* * * "Wealth and pride To obtain their wish—the world's applause" of course; but that's what we horticulturists are here for to a large extent.

Ino. Welch Young is laid up with typhoid fever. His many friends sincerely wish him a speedy recovery.

Robert Craig reports a very good holiday trade, although it was a little late in starting. Poinsettia, in Mr. Craig's opinion, deserves more care in culture. For fifty years this old favorite has held first place. Lorraine begonias and Dracaena terminalis were close seconds. Good cyclamens and azaleas were also favorites. A novelty for Easter will be the new German cluster rose (Tausendschon), of which some two thousand plants were prepared specially abroad for the occasion. The Dingee & Conard Co. are making a feature of this new variety in their catalogue trade this year.

W. E. McKissick is one of the many victims of the grip. There may be a few minor exceptions, hardly worthy of mention, but nearly all the men of mark have had their siege in the past few weeks.

P. Welch, Boston, was a visitor among the wholesale centres. We have also had the pleasure of seeing W. J. Stewart, Frank Traendly, J. K. Farquhar, W. H. Elliott, H. B. Beatty, W. F. Kasting, Wm. F. and Adolphus Gude, Willis N. Rudd, and other shining lights the past week.

PERSONAL.

Robert Simpson, president of the American Rose Society, is down with grippe at his home in Clifton, N. J.

While Mr. and Mrs. Robert Hunnack of Newport, R. I., were out driving on Christmas eve their carriage accidentally collided with a heavy wagon owned by V. A. Vanicek. They were thrown into the street and painfully cut and bruised. They were assisted home and medical aid summoned, and both are now rapidly recovering.

Visitors in New York this week include Messrs. Swoboda of Schmidt & Co., Erfurt, Sander of St. Albans, England, Howard M. Earl of Burpees, and Geo. C. Watson, Philadelphia, W. N. Rudd, Chicago, J. K. M. L. Farquhar and P. Welch, Boston, W. F. Kasting, Buffalo, J. N. Champion, New Haven, Conn., Carl Jurgens, Jr., Newport, R. I.

EXTRA FINE BOXWOOD \$17.50 per GWT.

FANCY FERNS, A No. 1 Quality, \$1.50 per 1000
GREEN CALAX \$1 per 1000, \$7.50 per 10,000
BRILLIANT BRONZ \$1 per 1000, \$8.50 per 10,000

Headquarters for HARDY FERNS, MOSS, LAUREL,
PRINCESS PINE, FESTOONING, Etc. See Our Cut Flower Ad.

HENRY M. ROBINSON & CO., FLORISTS' SUPPLIES 15 Province St., and 9 Chapman Pl., BOSTON

NEWS NOTES.

The John C. Moninger Co., Chicago, have the contract for furnishing the frame work, ventilating, etc., for the greenhouse to be built in the City Park, Denison, Texas.

The greenhouses of M. L. Tirrell, of Randolph, Mass., were badly damaged by fire on the morning of December 26. It is thought a defective pipe chimney was the cause. It is stated that no insurance was carried.

Edward Schnell, of St. Louis, Mo., was arrested recently for planting shade trees in front of his home, there being a city ordinance making it an offence to plant trees alongside a public walk. Judge O'Halloran while considering that the defendant had done a meritorious act, fined him \$5, which was suspended on promise to plant no more trees.



Floral Tribute to the Late John Clark by the Seed Trade of Boston.

BUSINESS CHANGES.

E. H. Lucking has purchased the Dowell greenhouse, Bradford, Pa.

D. H. Green succeeds to the business of Green & Baylis at West Grove, Pa.

Henry Seitz has taken over the business of Seitz & Nordell, Glenlake and Evanston avenues, Chicago.

On January 1 the firm name of Nathan Smith & Son, Adrian, Mich., was changed to Elmer D. Smith & Co., who will concentrate their efforts on the chrysanthemum and aster. Particulars are given in our advertising columns.

BOSTON FLORIST LETTER CO.
Manufacturers of FLORISTS' LETTERS

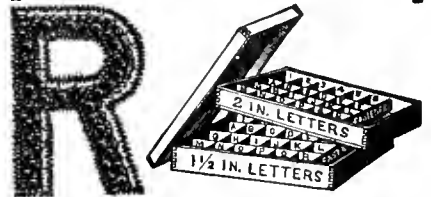

This wooden box nicely stained and varnished, 18x30x12, made in two sections, one for each size letter, given away with first order of 500 letters

Block Letters, 1 1/2 or 2 inch size per 100, \$2.
Script Letters, 3. Fastener with each letter or word. Used by leading florists everywhere and for sale by all wholesale florists and supply dealers

N. F. McCARTHY, Manager
66 Pearl Street, BOSTON, MASS.

KORAL SCRIPT LETTERS AND EMBLEMS

ONCE USED ALWAYS USED
Forsale by all first class supply houses. Made by
KORAL MFG. CO.
26 Hawley St., Boston

The "Japana" Cut Flower Holder

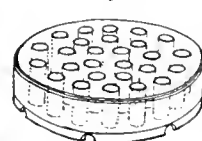

A handy article for florists. Sells to the trade on sight. Made of glass in three sizes. The "Anglais" Table Decoration, something entirely new, long needed. The florist and housewife will appreciate this article, as it simplifies the art of table decorating.

Ask for catalog.

M. V. CARNSEY, Dept. J,
130 Waiola Ave., La Grange, Ill.

GALAX LEAVES

New crop, fresh from the patch, prices as follows:

- Bronze and Green Galax Leaves..... \$1.50 per 1000
- Fancy and Dagger Ferns..... 1.00 per 1000
- Green Leucothoe Sprays..... 2.50 per 1000
- Bronze " "..... 1.00 per 1000
- Rhododendron Sprays..... 2.50 per 1000
- Kalmia or Mountain Laurel..... 2.50 per 1000

Discount on large orders. Fourteen years' experience enables me to guarantee perfect satisfaction. 250 customers now in U. S. Send cash with first order.

J. N. PRITCHARD, Elk Park, N. C.



FANCY and DAGGER FERNS

Best quality, \$1 per 1000

ROBERT GROVES
127 Commercial St. ADAMS, MASS.

E. A. BEAVEN
Southern Wild Smilax, Log Mosses,

Natural and Perpetuated — at Wholesale,

EVERGREEN, ALABAMA.

JOHN BREITMEYER'S SONS

Cor. Miami and Gratiot Aves.
DETROIT, MICH.

Artistic Designs . . .
High Grade Cut Blooms

We cover all Michigan points and good sections of Ohio, Indiana and Canada

P. J. HAUSWIRTH

232 Michigan Ave.
CHICAGO

AUDITORIUM ANNEX Tel. Harrison 585

SAMUEL MURRAY Florist

Coates House Conservatory
1017 BROADWAY, KANSAS CITY, MO
Both 'Phones 2670 Main

FRED C. WEBER FLORIST

4326-28 ST. LOUIS, MO.
OLIVE STREET
Established 1873
Long Distance Phone Bell Lindell 676



WASHINGTON,
D. C.

GUDE'S

Geo. H. Cooke FLORIST

Connecticut Avenue and L Street
WASHINGTON, D. C.

The Park Floral Co.

J. A. VALENTINE
Pres.

DENVER, COLORADO

WILLIAM L. ROCK FLOWER CO.

KANSAS CITY, MO.
will carefully execute orders for Kansas City and any town in Missouri or Kansas.

ALBANY, N. Y.

EYRES Flowers or Design Work

DELIVERED IN ALBANY AND VICINITY ON TELEGRAPHIC ORDER.
11 NORTH PEARL ST., ALBANY, N.Y.

NEWS NOTES.

The failure of Mackintosh, florist, 1144 Broadway, New York, is reported under date of December 28.

E. W. Pearson, of Newburyport, Mass., has recently added the raising of early vegetables to his florist business.

The Michigan Cut Flower Co., of Detroit, has started to use its cold storage ferns and every case opened so far has contained 26 good ferns to each bunch.

M. T. Twomey, proprietor of the Oak Hill Nurseries, Roslindale, Mass., has purchased about seventy-five acres of land at Wadsworth station on which to grow his nursery stock.

John E. Freudenberger, who will be remembered by those who attended the S. A. F. Convention at Dayton, has left the National Cash Register Company and will start a business of his own in Dayton.

Chas. L. Seybold, superintendent of Carroll Park, is chairman of the committee in charge of the flower show to be given in connection with the exhibition of the National Sculpture Society next April in Baltimore.

NEW RETAIL FLOWER STORES.

Messrs. Ulrich, Tiffin, O.
Mingham & Westwood, 122 Columbus avenue, New York.
Sawyer & Paine, 27 W. Bay street, Jacksonville, Fla.

LEADING RETAIL FLORISTS—
Index by Towns will be found in Buyers' Directory.



PROMPT DELIVERY IN BOSTON

AND ALL NEW ENGLAND POINTS
HOUGHTON & CLARK
396 Boylston St., Boston, Mass.

Send flower orders for delivery in
BOSTON
and all

NEW ENGLAND POINTS
THOS. F. CALVIN
124 Tremont St., Boston

TRANSFER

Your orders for flower or plant delivery in Eastern New England to

JULIUS A. ZINN,
2 Beacon St., Boston.

Fine Design Work a Specialty.

ATLANTA FLORAL CO.
41 Peachtree Street, ATLANTA GEORGIA.

Florists Out of Town

Taking orders for delivery in
New York or Vicinity
can have them filled in best manner and specially delivered by

Thomas Young, Jr.

41 W. 28th St., New York City

ALEX. McCONNELL

571 FIFTH AVENUE
NEW YORK CITY

Telegraphic orders forwarded to any part of the United States, Canada, and all principal cities of Europe. Orders transferred or intrusted by the trade to our selection for delivery on steamships or elsewhere receive special attention.

Telephone Calls, 487 and 488 38th St.
Cable Address, ALEXCONNELL

WILLIAM H. DONOHOE

FLORAL DECORATOR

17 East 28th St., New York

Special Attention to Theatre and Steamer Orders, and reliable deliveries guaranteed.

DAVID CLARKE'S SONS

Deliver orders from any part of the country to
New York City

Or OUT-GOING STEAMERS

Write or telegraph

2139-2141 Broadway, New York
Telephone 1552-1553 Columbus

A. WARENDORFF,

1193 Broadway,
NEW YORK.

Send your orders to the King of Floral Artists.

Flower Deliveries

In Brooklyn and other Long Island Points New York City, New Jersey, etc. At Theatres, Hotels, Steamers or Residences.

WILSON

Fulton St. and Greene Ave., Brooklyn, N.Y.

YOUNG & NUGENT

42 West 28 St., NEW YORK

"FLOWERS BY TELEGRAPH"

William J. Smyth FLORIST

Cor. Michigan Ave. and 31st St., CHICAGO

We ship to all points in Illinois and Iowa.

Phones: Douglas 744, Douglas 523, Douglas 740

JACOB SCHULZ, 644 Fourth Ave., LOUISVILLE, KY.
Cut Flowers of BEST QUALITY in season delivered promptly to any address.
Write, Telegraph or Telephone.
Cumberland and Home Phones 223 and 984

FLOWER MARKET REPORTS

BOSTON Reports of business throughout New England are generally favorable and indicate that normal conditions prevail in this section. Although the weather has been conducive to a heavy crop of flowers the demand from outside points has been very brisk and Boston houses doing a shipping trade have been very fortunate as the call has been very steady ever since Christmas. Locally the business has not been so satisfactory, possibly owing to the fact that the retail trade in the city is pretty well loaded up with plants, which are naturally given first chance at a sale. At present writing cut flower prices are advancing slightly over the rates prevailing in the early part of the week. Lily of the valley, hyacinths and narcissi are the most sluggish stock at present. This bulb forcing seems to be overdone.

BUFFALO The holiday trade for 1907 was a hummer, if not a record breaker. The balance of the old year was carried out with a good volume of business and as large, if not larger, than previous years, in spite of the so-called hard times. Holly and other festooning in the decorating line was well cleaned up, save Xmas trees, of which there were a few left for souvenirs. The shipping trade was excellent, trains running fairly well on time and there was not so much worry as in previous years. In the plant line Lorraine begonias sold well and primulas and other flowering plants exceeded last year's sales. Azaleas were not plentiful and poinsettias were rather short. The cut flower stock was in good supply; Beauties in excellent quality and plenty to be had; Richmond of select quality were short in supply and prices ruled high; Killarney and other roses sold exceptionally well; violets were plentiful enough and cleaned up better than previous years; lily of the valley, peas, orchids and gardenias were in good demand, while narcissi were a "flood" and prices dropped exceedingly low. As usual on holidays, the carnation is in most demand, especially red; the latter were short in supply and red Lawson held out to good advantage. Other varieties were a trifle scarce at the beginning of each holiday week, but all orders were completely filled and a good cleaning up was had. There was an enormous supply of greens, especially smilax, though other greens, especially ferns, were well in demand.

DETROIT Every florist regrets having built his calculations on newspaper items yelling panic, and finding himself therefore not sufficiently prepared for the Christmas trade. Such was the predicament of a great majority. Everything sold at the same good prices of last year and a good deal more would have been turned into dollars if the goods had been here. But even with our scarcity of flowers, especially in carnations, we noticed with great satisfaction a lot of about 2,000 Lawson and Enchantress which must have been held back at least ten days go to the dump. May that be a lesson not only for this grower but for all others who believe in crowding the holiday

market with pickled stock. Some large decorations are booked for the New Year's ball, making business in general satisfactory.

INDIANAPOLIS The reports of the different retailers vary as to Christmas trade. Some claim that business was away ahead of last year, others about 15 per cent. less, but as a whole everybody seems well satisfied. Despite the cry of scarcity of flowers there appeared to be a large quantity. A big supply of flowering plants was on hand and relieved the market to a great extent. The principal scarcity was in large and medium azaleas. Great quantities of Lorraine begonias were sold but they don't bring the prices and have the run that they used to. The general impression was that prices of flowers would surely weaken, but orchids, lily of the valley, violets and fancy grades of Beauties and teas brought prices fully up to those of a year ago. Holly was a great disappointment; little or no fancy holly was to be seen and it was not equal to the demand. There was nothing in the way of a novelty. The absence of freezing weather was a great advantage in the delivery of flowers and plants. Christmas greens of all kinds were among the best selling articles and helped considerably to swell the receipts of many of the retailers.

NEWPORT The prices obtained for plants and flowers at Christmas equalled those ruling on former occasions with perhaps a trifle higher figure for some things. There were good supplies of all salable material and there was nothing of any account left over. Cyclamens, Lorraine begonias, poinsettias and ardisias sold well. Ferns went quickly in small and medium sizes. Holly was a profitable item from the start. Cut flowers were in most all lines in supply about equal to the demand. There was a big demand for American Beauty roses towards the close, and it could hardly be met for immediate delivery. Every man in the business had all the work he could attend to for two days and when it came to the end there was but very little left unsold.

NEW YORK It is now several years since most of the glory of New Year's Day as an occasion of great floral importance in New York departed. This season's event was, therefore, not expected to make any sensational record and the fact is that it did not. Still there is a very evident feeling of satisfaction with the results generally of the New Year's business. This is particularly true of the retail dealers, who are naturally pleased with the moderate wholesale prices at which choice material has been obtainable all through the holiday season as compared with former years. Never before has it been possible to obtain holiday gardenias, cattleyas and special American Beauty roses at the figures prevalent since Christmas. Cattleyas are in very heavy supply at the present time in this market. Violets are plentiful but of excellent quality and have maintained value unusually well, there being, however, a good

many stale bunches from some shippers. Lily of the valley is probably the most unfortunate flower on the whole list, the receipts in wholesale market far exceeding the requirements, necessitating the calling in of the fukir to help unload at "bargain counter" prices. Much of the lily of the valley is below standard of quality. Roman hyacinths and paper-white narcissi have been hard to move. Carnations have done well. Plants such as Lorraine begonias, poinsettias, heaths and azaleas figured largely in the window displays and general stock of the retail florists, the inference being that this class of material was not fully sold out at Christmas.

PHILADELPHIA While the inevitable easing up of prices took place after the Christmas rush business was fairly satisfactory last week, and aided by a good out-of-town demand kept the distributors on the jump—even on Sunday. At this writing (Monday) prospects for the new year trade are good, and if the weather is anything like propitious very little will go to waste. American Beauty roses continue of splendid quality and dominate the market. Brides and Bridesmaids have improved considerably as to color and hold firm as to prices. Richmonds are in good demand. Chatenay and Wellesley are in evidence, but these do not cut a wide swath in this market. Killarney is very good at present. The carnation market holds its own nicely as to prices, and quantity and quality is all that could be wished. Lily of the valley is still rather too plentiful for the demand. Violets, while good stock, do not go with quite the usual snap. Orchids are plentiful with healthy demand. Romas and narcissi are in over-supply, yet there is usually found a place for them somewhere. Mignonne continues very good stock—one of the most satisfactory on the market. Poinsettias are very fine as to quality, with values much in buyers' favor.

WASHINGTON The phenomenally beautiful weather that has lasted through almost the entire Christmas holidays has proved a boon to the florists generally. All retailers express themselves as more than pleased with the outcome. Small potted plants sold unusually well. Richmond and Killarney roses are more in demand than others, but Beauty is about the only rose that keeps up in price. The large retailers have their hands pretty full with the New Year decorating. It is feared that the continued warm weather will be a great menace to hardy plants and climbers. Nearly everything is coming into good bud.

TWIN CITIES Business was good and the outlook for this week is bright. Prices are steady, retailers complaining they are too high to make a fair profit. Roses and carnations are shipped in from Illinois as well as from Iowa in large numbers.

The KERVAN CO. 113 W. 25th St. New York

WHOLESALE DEALERS
Fresh, Imported and Grown in Italy, France, Germany, Holland, and Mexico. All Decorating and Holiday Goods.



HARDY CUT FERNS

Sphagnum Moss, Extra Large Bales, per bale, \$1.25. Fancy and Dagger Ferns our specialty. A trial order will convince you that we ship only first-class stock. Headquarters for Florists' supplies and wire work. All cut flowers in season. **BOXWOOD**, per bunch 35c, 50 lbs. \$7.50.

MICHIGAN CUT FLOWER EXCHANGE, INC., All 'phone connections 38-40 Broadway, Detroit, Mich.

FANCY and DAGGER
Extra fine, \$1.50 per 1000. Bronze and Green Galax, \$1.25 per 1000. Leucothoe Sprays, \$1.00 per 100, \$7.50 per 1000.

WHOLESALE FLORISTS
54 West 28th St.
NEW YORK
Telephone 3559 Madison Sq.

A. L. YOUNG & CO.

RECEIVERS & SHIPPERS OF CUT FLOWERS.
CONSIGNMENTS SOLICITED.

Headquarters in Western New York
FOR
ROSES, CARNATIONS
And all kinds of Seasonable Flowers
Wm. F. Kasting Co.
Wholesale Commission Florist, also Dealer in Florists' Supplies and Wire Designs.
383-87 ELLICOTT ST. BUFFALO, N. Y.
Give us a trial. We can please you.

FRANK S. HICKS & CO.
Wholesale Florists.
Open Now for Consignments of Cut Flowers.
52 West 28th Street, - New York City
Tel. 2920 Mad. Sq.

FRANK MILLANG
Wholesale Florist
Telegraphic Orders Filled and Delivered.
55-57 West 26th St., New York City.

Charles Millang
50 West 29th St., New York City
Cut Flowers on Commission
A Reliable Place to Consign to or order from
Telephone: 3860-3871 Madison Square

A. MOLTZ
Will purchase flowers on order in N. Y. market and ship carefully at prevailing wholesale prices. Address
55-57 West 26th Street, New York City

Best Flowers
IN THE
BOSTON MARKET
N. F. McCarthy & Co.
84 Hawley St., BOSTON, MASS.
Send for Prices

HENRY M. ROBINSON & CO.
WHOLESALE COMMISSION FLORISTS
Finest Grades of Roses, Carnations, Chrysanthemums, Lily of the Valley, Violets, etc.
15 Province St. & 9 Chapman Pl., Boston, Mass.
See our Fern ad.

SAMUEL A. WOODROW
WHOLESALE PLANTSMAN
Palms, Large and Small Ferns, etc.
53 West 30th Street, NEW YORK
Telephone 2083 Madison

WILLIAM H. KUEBLER
Brooklyn's Foremost and Best
WHOLESALE COMMISSION HOUSE
A First Class Market for all CUT FLOWERS
28 Willoughby St., Brooklyn, N. Y.
Tel. 4591 Maio

CLEARY'S HORTICULTURAL CO.
Management AMBROSE T. CLEARY
Wholesale Contracting, Jobbing, Auction
HORTICULTURAL PRODUCTS
of every description.
Consignments Received. Surplus Stock Converted.
62 Vesey St., NEW YORK

Moore, Hentz & Nash,
Wholesale Commission Florists,
55 and 57 West 26th Street,
Telephone No. 756
Madison Square. **New York.**

WHOLESALE FLOWER MARKETS. — PER 100. TO DEALERS ONLY.

	CINCINNATI Dec. 31	DETROIT Dec. 24	BUFFALO Dec. 31	PITTSBURG Dec. 31
ROSES				
Am. Beauty, Fan. and Sp.	50.00 to 75.00	75.00 to 100.00	75.00 to 85.00	50.00 to 75.00
" Extra	40.00 to 50.00	50.00 to 75.00	50.00 to 50.00	30.00 to 40.00
" No. 1	20.00 to 30.00	25.00 to 30.00	20.00 to 30.00	10.00 to 20.00
" Lower grades	10.00 to 15.00	8.00 to 10.00	10.00 to 20.00	5.00 to 8.00
Bride, 'Maid, F. & S.	10.00 to 12.00	10.00 to 12.00	10.00 to 15.00 to 15.00
" Extra	8.00 to 10.00	8.00 to 10.00	10.00 to 12.00 to 12.00
" Low. gr.	6.00 to 8.00	6.00 to 8.00	4.00 to 6.00	6.00 to 10.00
Killarney, Richmond, Fan. & Sp.	10.00 to 12.00	10.00 to 18.00	8.00 to 10.00	15.00 to 20.00
" Lower grades	10.00 to 8.00	6.00 to 10.00	4.00 to 6.00	8.00 to 10.00
Chateau, Wellesley, Fan. & Sp.	10.00 to 12.00	10.00 to 18.00	8.00 to 15.00 to 15.00
" Lower grades	6.00 to 8.00	6.00 to 10.00	4.00 to 8.00	8.00 to 12.00
Golden Gate, Ivory	8.00 to 10.00	10.00 to 18.00	6.00 to 12.00	6.00 to 10.00
CARNATIONS				
Fancy and Novelties	6.00 to 8.00	6.00 to 10.00	5.00 to 7.00 to 6.00
Ordinary	3.00 to 4.00	4.00 to 6.00	3.00 to 5.00	4.00 to 5.00
MISCELLANEOUS				
Violets	1.00 to 1.50	1.50 to 2.50	1.00 to 2.00	.75 to 1.25
Cactleys	50.00 to 75.00 to 75.00	60.00 to 75.00
Cyripediums	8.00 to 12.00 to 25.00 to 15.00
Lilies to 15.00	15.00 to 20.00	4.00 to 15.00	15.00 to 20.00
Lily of the Valley to 4.00	4.50 to 5.50	3.00 to 5.00	4.00 to 6.00
Roman Hy., Paper White Nar.	3.00 to 4.00	4.00 to 8.00	2.00 to 5.00	2.00 to 3.00
Pofosettias	20.00 to 30.00	25.00 to 50.00	15.00 to 40.00	20.00 to 50.00
Stevia	1.00 to 1.50	2.00 to 3.00	1.00 to 1.25	1.00 to 2.00
Mignonette	3.00 to 6.00	3.00 to 6.00	3.00 to 6.00	4.00 to 8.00
Chrysanthemums to 10.00	10.00 to 25.00 to 10.00 to 10.00
Adiantum to 1.00	1.50 to 2.50	.50 to 1.50	1.00 to 1.25
Smilax to 15.00	15.00 to 20.00 to 15.00 to 15.00
Asparagus Plumosus, strings	40.00 to 50.00	50.00 to 75.00	40.00 to 60.00 to 50.00
" " & Sprea. (100 bchs.)	25.00 to 35.00	40.00 to 70.00	35.00 to 50.00	30.00 to 50.00

H. C. BERNING
Wholesale Florist
1402 Pine Street, ST. LOUIS, MO.

J. B. Murdoch & Co.
Wholesale Florists
FLORISTS' SUPPLIES
545 Liberty St., PITTSBURG, PA.
Long Distance 'Phone 1435 Court.

Alex Mann, Jr. Co. Inc.
Wholesale Dealer in
Florists' Supplies and Cut Flowers
White Doves, \$9.00 per doz.
Galax Leaves.
1125 Polk Street, San Francisco, Cal.

REED & KELLER
122 West 25th St., New York
Florists' Supplies
We manufacture all our
Metal Designs, Baskets, Wire Work & Novelties
and are dealers in
Glassware Decorative Greens and Florists' Requisites.

Buyer's Directory and Ready Reference Guide

Advertisements under this head, one cent a word. Initials count as words.

Regular advertisers in this issue are also listed under this classification without charge. Reference to List of Advertisers will indicate the respective pages.

Buyers falling to find what they want in this list will confer a favor by writing us and we will try to put them in communication with reliable dealers.

ACCOUNTANT

R. J. Dysart, 28 State St., Boston.
For page see List of Advertisers.

AQUARIUM PLANTS

Aquarium plants, the year around. Wholesale and retail. Send for price list.
Schmid's Emporium of Pets, 712 12th St., Washington, D. C.

ARAUCARIAS

Godfrey Aschmann, 1012 Ontario St., Philadelphia, Pa.
For page see List of Advertisers.

ARTIFICIAL CALYX

Maxfield & Dimond, Warren, R. I.
For page see List of Advertisers.

ASPARAGUS

Asparagus Sprenger, field grown, \$4.00 and \$6.00 per 100. C. Winterlich, Defiance, Ohio.

Asparagus Plumosa, 2 in. pots. Fine plants. \$2.50 per 100; \$20.00 per 1000. Cash with order or good reference. Erie Floral Co., Erie, Pa.; or, Wm. F. Kasting Co., 385 Ellicott St., Buffalo, N. Y.

AUCTION SALES

Cleary's Horticultural Co., 62 Vesey St., New York.
Horticultural Products of Every Description.
For page see List of Advertisers.

Sales every Tuesday and Friday. If you cannot attend send bids and shipping instructions. Catalogues on application. N. F. McCarthy & Co., 84 Hawley St., Boston.

AZALEAS

A. Leuthy & Co., Perkins St. Nurseries, Roslindale, Mass.
For page see List of Advertisers.

W. W. Edgar Co., Waverley, Mass.
For page see List of Advertisers.

Bay State Nurseries, N. Abington, Mass.
For page see List of Advertisers.

Bobbink & Atkins, Rutherford, N. J.
For page see List of Advertisers.

BAMBOO CANES

Stump & Walter Co., 50 Barclay St., New York.
For page see List of Advertisers.

Yokohama Nursery Co., 31 Barclay Street, New York.
For page see List of Advertisers.

BAY TREES.

Specimens and pairs, all sizes. Send for prices. N. F. McCarthy & Co., 84 Hawley St., Boston.

Bay Trees and Box Trees, standards and pyramids. All sizes. Price list on application. J. Roehrs Co., Rutherford, N. J.

BOILERS

BOILERS. "Burnham" Boilers made for greenhouse heating. Lord & Burnham, 1133 Broadway, N. Y.

BOXWOOD

A. Leuthy & Co., Perkins St. Nurseries, Roslindale, Mass.
For page see List of Advertisers.

Henry M. Robinson & Co., 15 Province St., Boston.
For page see List of Advertisers.

BUILDING MATERIAL

BUILDING MATERIAL of all description for All Cypress, Semi-Iron, Iron Frame or Truss Houses. Hot Bed Sash and Frames. Lord & Burnham Co., 1133 Broadway, N. Y.

BULBS AND TUBERS

Joseph Breck & Sons, 47-54 N. Market St., Boston.
For page see List of Advertisers.

J. M. Thornburn & Co., 33 Barclay St., New York.
Roman Hyacinths; Bermuda Easter Lilies.
For page see List of Advertisers.

A. T. Roddington, 342 W. 14th St., N. Y.
For page see List of Advertisers.

Rickards Bros., 37 East 19th St., New York.
For page see List of Advertisers.

J. F. Mitchell Co., Philadelphia.
For page see List of Advertisers.

H. E. Fiske Seed Co., Faneuil Hall Sq., Boston.
For page see List of Advertisers.

James Vick's Sons, Rochester, N. Y.
Fall Bulbs.
For page see List of Advertisers.

D. Rusconi, 128 W. Sixth St., Cincinnati, O.
Callas, Narcissi, Dutch Bulbs.
For page see List of Advertisers.

Aug. Rolker & Sons, 31 Barclay St., New York.
Seasonable Import Plants and Bulbs.
For page see List of Advertisers.

John Scheepers & Co., 4 and 6 Old Slip, New York.
Lily of the Valley Excellents.
For page see List of Advertisers.

K. Velthuis, Hillegom, Holland.
Represented by Felix Bosch, 260 Clarendon St., Boston.
Bulbs French and Dutch.
For page see List of Advertisers.

Write for prices on only selected bulbs, plants, etc. F. W. O. Schmitz, Prince Bay, N. Y.

25 Lily of Valley, postpaid, 80 cts; 200 Dunlap, Warfield Strawberry plants, postpaid, \$1.35 Catalogue free. Alva Y. Cathcart, Bristol, Indiana.

CARNATIONS

Field Grown

The H. Weber & Sons Co., Oakland, Md.
Seedling Carnation Treador.
For page see List of Advertisers.

Rooted Cuttings

John E. Haines, Bethlehem, Pa.
For page see List of Advertisers.

F. Dornier & Sons Co., Lafayette, Ind.
For page see List of Advertisers.

S. S. Skidelsky, 1741 N. 18th St., Philadelphia.
For page see List of Advertisers.

Frank H. Kimberly, 631 Townsend Ave., New Haven, Ct.
For page see List of Advertisers.

Chicago Carnation Co., Joffet, Ill.
For page see List of Advertisers.

F. R. Pierson Co., Tarrytown, N. Y.
For page see List of Advertisers.

CHRYSANTHEMUMS

Charles H. Totty, Madison, N. J.
For page see List of Advertisers.

Nathan Smith & Son, Adrian, Mich.
Novelty Chrysanthemums.
For page see List of Advertisers.

A. N. Pierson, Cromwell, Conn.
Chrysanthemum Stock Plants.

W. W. Edgar Co., Waverley, Mass.
For page see List of Advertisers.

BARGAIN in stock Chrysanthemums. 150 Yellow Appleton, 100 Robinson, at 2½c. Also 25 large, bushy Wall-flowers, 4c. The lot for 87 G. S. Rainsburg, 275 High St., Somersworth, N. H.

Chrysanthemums, strong stock plants of Bonnaillon, Enguehard, Nonin, J. Jones, etc., \$4.00 per 100. Rooted cuttings of Clay Erick and Beatrice May, \$5.00 per 100. Frank Shearer & Son, Binghamton, N. Y.

Chrysanthemum stock plants. White—Clementine Tonset, Polly Rose, Bergmann, Ivory, Robinson, Alice Byron, Mrs. Eno, Jeanne Nonin, Pink—Pacific, A. J. Balfour, Wm. Duckham, Enguehard, Lady Hopetoun. Yellow—Monrovia, Sunshine, Halliday, Bonnaillon, Co. Appleton. 50c. per doz.; \$3.50 per 100. Stafford Floral Co., Stafford Springs, Conn.

CINERARIAS

John J. Coonan, Haverstraw, N. Y.
For page see List of Advertisers.

CONIFERS

John Waterer & Sons, Ltd., America Nursery, Bagshot, Eng.
For page see List of Advertisers.

Bay State Nurseries, North Abington, Mass.
For page see List of Advertisers.

Write for prices on all choice ornamental conifers. N. F. McCarthy & Co., 84 Hawley St., Boston, Mass.

CUT FLOWER BOXES.

Edwards Folding Box Co., Philadelphia.
For page see List of Advertisers.

Getmore Box Factory, Inc., Belleville, Ala.
Light Wood Boxes.

We Have Them.
Send for New Illustrated Catalogue.
H. Bayersdorfer & Co.,
1129 Arch St., Philadelphia, Pa.

Folding cut flower boxes, the best made. Write for list. Holton & Hunkel Co., Milwaukee, Wis.

CYCLAMEN.

Thomas Roland, Nahant, Mass.
For page see List of Advertisers.

DAHLIAS

David Herbert & Son, Ateo, N. J.
For page see List of Advertisers.

J. L. Moore, Northboro, Mass.
For page see List of Advertisers.

A. B. Davis & Son, Purcellville, Va.
For page see List of Advertisers.

DECORATIVE PLANTS

A. Leuthy & Co., Roslindale, Mass.
For page see List of Advertisers.

Julius Roehrs, Rutherford, N. J.
For page see List of Advertisers.

Anton Schulthels, College Point, N. Y.
For page see List of Advertisers.

For List of Advertisers See Page 24

FERNS

- A. Leuthy & Co., Roslindale, Mass.
For page see List of Advertisers.

- H. H. Barrows & Son, Whitman, Mass
Nephrolepis Whitmani.
For page see List of Advertisers.

- Godfrey Aschmann, 1012 Ontario St.,
Philadelphia, Pa.
For page see List of Advertisers.

- John Scott, Brooklyn, N. Y.
For page see List of Advertisers.

FERTILIZERS

- Pulverized Manure Co., 31 Union Stock
Yards, Chicago, Ill.
Wizard Brand Cattle Manure.
For page see List of Advertisers.

- Thos. J. Grey & Co.,
32 and 33 South Market St., Boston.
High-Grade Scotch Soot.
For page see List of Advertisers.

FLORISTS' GREENING PINS

- We Have Them.
Send for New Illustrated Catalogue.
H. Bayersdorfer & Co.,
1129 Arch St., Philadelphia, Pa.

FLORAL PHOTOGRAPHS

- Floral Photographs. Foley's 226-228 1-2
Bowery, New York.

FLORISTS' LETTERS.

- Boston Florist Letter Co., 66 Pearl St.,
Boston, Mass.
For page see List of Advertisers.

- Koral Mfg. Co., 26 Hawley St., Boston.
For page see List of Advertisers.

- We Have Them.
Send for New Illustrated Catalogue.
H. Bayersdorfer & Co.,
1129 Arch St., Philadelphia, Pa.

FLORISTS SUPPLIES

- H. M. Robinson & Co., 15 Province St. and
9 Chapman Pl., Boston, Mass.
For page see List of Advertisers.

- The Keivan Co., 113 W. 28th St., N. Y.
Decorative Evergreens.
For page see List of Advertisers.

- Reed & Keller, 122 W. 25th St., New York.
For page see List of Advertisers.

- J. B. Murdoch & Co., 545 Liberty St.,
Pittsburg, Pa.
For page see List of Advertisers.

- H. Bayersdorfer & Co., 1129 Arch St.,
Philadelphia.
For page see List of Advertisers.

- Alex. Mann, Jr., Co., 1125 Polk St., San
Francisco, Calif.
For page see List of Advertisers.

FLOWERS BY TELEGRAPH

- Park Floral Co., Denver, Colo.
For page see List of Advertisers.

- George H. Cooke, Washington, D. C.
For page see List of Advertisers.

- Gude Bros. Co., 1214 F St.,
Washington, D. C.
For page see List of Advertisers.

- Atlanta Floral Co., Atlanta, Ga.
For page see List of Advertisers.

- P. J. Hauawith, 232 Michigan Ave.,
Chicago.
For page see List of Advertisers.

- William J. Smyth, Michigan Ave. and 31st
St., Chicago.
For page see List of Advertisers.

- Jacob Schulz, 644 4th Ave., Louisville, Ky.
For page see List of Advertisers.

- Thos F. Galvin, 124 Tremont St., Boston.
For page see List of Advertisers.

- Julius A. Zinn, 2 Beacon St., Boston.
For page see List of Advertisers.

- Houghton & Clark, 396 Boylston St.,
Boston.
For page see List of Advertisers.

FLOWERS BY TELEGRAPH —

Continued

- Sidney Hoffmau, 59-61 Massachusetts Ave.,
Boston.
For page see List of Advertisers.

- J. Breitmeyer's Sons, Miami and Gratiot
Aves., Detroit, Mich.
For page see List of Advertisers.

- Samuel Murray, 1017 Broadway,
Kansas City, Mo.
For page see List of Advertisers.

- Wm. L. Rock Flower Co., 1116 Walnut
St., Kansas City, Mo.
For page see List of Advertisers.

- Theodore Miller, 4832 Delmar Bvd.,
St. Louis, Mo.
Fred C. Weber, 4326-28 Olive St.,
St. Louis, Mo.
For page see List of Advertisers.

- H. G. Eyres, 11 N. Pearl St., Albany, N.Y.
For page see List of Advertisers.

- David Clarke's Sons, 2159-2141 Broadway,
New York.
For page see List of Advertisers.

- W. H. Donohoe, 17 E. 23rd St., New York.
For page see List of Advertisers.

- Alex. McConnell, New York.
For page see List of Advertisers.

- A. Warendorff, 1193 Broadway, New York.
For page see List of Advertisers.

- Robert G. Wilson, Fulton St. & Greene
Av., Brooklyn, N. Y.
For page see List of Advertisers.

- Thos. Young, Jr., 41 W. 28th St., N. Y.
For page see List of Advertisers.

- Young & Nugent, 42 W. 28th St., N. Y.
For page see List of Advertisers.

- Mills, the Florist, Jacksonville, Fla.
Telegraph or mail orders promptly filled.
Long distance telephone connections.

FLOWER POTS

- W. H. Ernest, 28th and M Sts.,
Washington, D. C.
For page see List of Advertisers.

- A. H. Hews & Co., Cambridge, Masa.
For page see List of Advertisers.

- Hilfinger Bros., Ft. Edward, N. Y.
For page see List of Advertisers.

FORCING ROOTS

- Robbuck & Atkins, Rutherford, N. J.
For page see List of Advertisers.

GALAX

- Michigau Cut Flower Co., 38 and 40 Broad-
way, Detroit, Mich.
For page see List of Advertisers.

- Finest green and bronze Galax in any
quantity at lowest figures. N. F. Mc-
Carthy, 84 Hawley St., Boston.

GERANIUMS

- We Have It.
Send for New Illustrated Catalogue.
H. Bayersdorfer & Co.,
1129 Arch St., Philadelphia, Pa.

- GERANIUMS**
R. Vincent Jr. & Sons Co., White Marsh,
Md.
New and Standard Varieties.
For page see List of Advertisers.

GLADIOLI

- Arthur Cowee, Meadowvale Farm, Berlin,
New York.
For page see List of Advertisers.

- J. L. Moore, Northboro, Mass.
For page see List of Advertisers.

- Gladioli. Write for leaflet. B. Ham-
mond Tracy, Cedar Acres, Wenham, Mass.
Groff's hybrid, mixed. Order at once for
best bulbs. E. R. Macomber, Woodfords,
Maine.
15,000 Groff's Hybrid Gladiolus Bulbs to
close out at a bargain; extra large and
monster bulbs at 88 and \$10 per 1000. Cash,
please. E. A. Muchow, Clarence, N. Y.

GLADIOLI — Continued

- Gladiolus Bulbs, Groff's Hybrids, extra
large and nice bulbs measuring as high
as 10 and 12 inches in circumference, \$1.50
per 100; \$12.00 per 1000. Cash. E. A.
Muchow, Clarence, N. Y.

- Gladioli Colvilli Alba, \$1.00 per 100;
\$7.50 per 1000. Gladioli Rosea, \$1.25 per
100; \$9.00 per 1000. America, light pink,
immense flower, \$1.00 per doz.; \$7.50 per
100. Cushman Gladiolus Co., Sylvania, O.

GLASS

- Boston Plate & Window Glass Co., Boston.
For page see List of Advertisers.

- Standard Plate Glass Co., 26-30 Sudbury
St., Boston.
For page see List of Advertisers.

- Foley Mfg. Co., between Western Ave. and
26th St., Chicago, Ill.

- GLASS, High Grade, Double Thick Green-
house Glass. Lord & Burnham, 1133 Broad-
way, N. Y.

GLAZING POINT

- H. A. Dreer, Philadelphia, Pa.
For page see List of Advertisers.

- GLAZING POINTS, Lord & Burnham
Special Glazing Nails (Points). Lord &
Burnham, 1133 Broadway, N. Y.

**GREENHOUSE BUILDING MATE-
RIAL.**

- Lord & Burnham Co.,
1133 Broadway, New York.
For page see List of Advertisers.

- Pierson U-Bar Co., 1 Madison Sq., N. Y.
For page see List of Advertisers.

- Hitchings & Co., 1170 Broadway, N. Y.
For page see List of Advertisers.

- A. T. Stearns Lumber Co., Neponset,
Boston.
For page see List of Advertisers.

- King Construction Co., N. Tonawanda,
New York.
For page see List of Advertisers.

- J. C. Moninger Co., 117 East Blackhawk St.,
Chicago, Ill.
For page see List of Advertisers.

- Foley Mfg. Co., between Western Ave. and
26th St., Chicago, Ill.
For page see List of Advertisers.

- I. Cassidy, 215-21 Randolph Ave., Jersey
City, N. J.
For page see List of Advertisers.

- Metropolitan Material Co., 1398-1408 Metro-
politan Ave., Brooklyn, N. Y.
For page see List of Advertisers.

- S. Jacobs & Sons, 1365-79 Flushing Ave.,
Brooklyn, N. Y.

- D. Hille, 49 Washington St., N., Boston
Piping and Construction.

GREENHOUSE CONSTRUCTION

- GREENHOUSE CONSTRUCTION, Semi-
Iron Greenhouse, New Truss Houses and
Iron Frame Houses. Lord & Burnham,
1133 Broadway, N. Y.

- J. A. Payne, 260-274 Culver Ave., Jersey
City, N. J.
For page see List of Advertisers.

- I. Cassidy, 215 to 221 Randolph Ave., Jer-
sey City, N. J.
For page see List of Advertisers.

- Foley Mfg. Co., between Western Ave. and
26th St., Chicago, Ill.

GREENHOUSE HOSE

- Mineralized Rubber Co., 18 Cliff St., N. Y.
For page see List of Advertisers.

GUTTERS

- GUTTERS, Cast Iron Gutters, L. & B.
Improved V Shaped Gutter with drip gut-
ter attachment. Lord & Burnham, 1133
Broadway, N. Y.

HAIL INSURANCE

- Florists' Hail Asso. of America.
J. G. Esler, Saddle River, N. J.
For page see List of Advertisers.

In writing to Advertisers kindly mention Horticulture

HARDY FERNS AND SUPPLIES

H. M. Robinson & Co., 15 Province St. and 9 Chapin Pl., Boston, Mass.
For page see List of Advertisers

The Kervan Co., 113 W. 28th St., N. Y.
For page see List of Advertisers.

Michigan Cut Flower Exchange,
38 and 40 Broadway, Detroit, Mich.
Fancy Ferns.
For page see List of Advertisers.

Robert Groves, 127 Commercial St.,
Adams, Mass.
For page see List of Advertisers.

A full line of ferns, galax, and all wild greens. N. F. McCarthy & Co., 84 Hawley St., Boston.

HARDY HERBACEOUS PLANTS

Bay State Nurseries, N. Abington, Mass.
For page see List of Advertisers.

New England Nurseries, Inc., Bedford, Mass.
For page see List of Advertisers.

HEATING APPARATUS

Lord & Burnham Co.,
1133 Broadway, New York.
For page see List of Advertisers.

Pierson U-Bar Co., 1 Madison Sq., N. Y.
For page see List of Advertisers.

Hitchings & Co., 1170 Broadway, N. Y.
For page see List of Advertisers.

John A. Payne, 260-274 Culver Ave., Jersey City, N. J.
For page see List of Advertisers.

HOT-BED MATS

Wm. Elliott & Sons, 201 Fulton St.,
New York.
For page see List of Advertisers.

HOT-BED SASH

The A. T. Stearns Lumber Co., Neponset, Mass.
For page see List of Advertisers.

Pierson U-Bar Co., 1 Madison Sq., N. Y.
For page see List of Advertisers.

Hitchings & Co., 1170 Broadway, N. Y.
For page see List of Advertisers.

Lord & Burnham Co., 1133 Broadway, N. Y.
For page see List of Advertisers.

Foley Mfg. Co., between Western Ave. and 26th St., Chicago, Ill.

HYDRANGEA OTAKSA

Baur Floral Co., Erie, Pa.
For page see List of Advertisers.

INSECTICIDES.

Andrew Wilson, Summit, N. J. Dept. 8.
Plant Oil.
For page see List of Advertisers.

Carman's Anti-pest.
Perfection Chemical Co., Flushing, N. Y.
W. W. Rawson & Co., 5 Union St., Boston.
For page see List of Advertisers.

Nicotinide kills all greenhouse pests.
P. R. Palethorpe Co.,
Eleventh St., Owensboro, Ky.
For page see List of Advertisers.

Nicotine Mfg. Co., St. Louis, Mo.
Nikoteen.
For page see List of Advertisers.

JAPANA CUT FLOWER HOLDER

M. V. Garnsey, 130 So. Walola Av., La Grange, Ill. Dept. J.
For page see List of Advertisers.

We Have Them.

Send for New Illustrated Catalogue.
H. Bayersdorfer & Co.,
1129 Arch St., Philadelphia, Pa.

KENTIAS

A. Leuthy & Co., Rosindale, Mass.
For page see List of Advertisers.
Godfrey Aschmann, 1012 W. Ontario St., Philadelphia.
For page see List of Advertisers.

LEADING RETAIL FLORISTS

Park Floral Co., Denver, Colo.
For page see List of Advertisers.

George H. Cooke, Washington, D. C.
For page see List of Advertisers.

Gude Bros. Co., 1214 F St.,
Washington, D. C.
For page see List of Advertisers.

Atlanta Floral Co., Atlanta, Ga.
For page see List of Advertisers.

P. J. Hauswirth, 232 Michigan Ave.,
Chicago.
For page see List of Advertisers.

William J. Smyth, Michigan Ave. and 31st
St., Chicago.
For page see List of Advertisers.

Jacob Schulz, 644 4th Ave., Louisville, Ky.
For page see List of Advertisers.

Thos. F. Galvin, 124 Tremont St., Boston.
For page see List of Advertisers.

Julius A. Zinn, 2 Beacon St., Boston.
For page see List of Advertisers.

Houghton & Clark, 396 Boylston St.,
Boston.
For page see List of Advertisers.

Sidney Hoffman, 59-61 Massachusetts Ave.,
Boston.
For page see List of Advertisers.

J. Breitmeyer's Sons, Detroit, Mich.
For page see List of Advertisers.

Samuel Murray, 1017 Broadway,
Kansas City, Mo.
For page see List of Advertisers.

Wm. L. Rock Flower Co., 1116 Walnut
St., Kansas City, Mo.
For page see List of Advertisers.

Kansas City, Mo., Alpha Floral Co.

Theodore Miller, 4832 Delmar Bvd.,
St. Louis, Mo.

Fred C. Weber, 4326 Olive St., St. Louis,
Mo.
For page see List of Advertisers.

H. G. Eyres, 11 N. Pearl St., Albany, N. Y.
For page see List of Advertisers.

David Clarke's Sons, 2139-2141 Broadway,
New York.
For page see List of Advertisers.

W. H. Donohoe, 17 E. 28th St., New York.
For page see List of Advertisers.

Alex. McConnell, New York.
For page see List of Advertisers.

A. Warendorff, 1193 Broadway, New York.
For page see List of Advertisers.

Robert G. Wilson, Fulton St. and Greene
Ave., Brooklyn, N. Y.
For page see List of Advertisers.

Thomas Young, Jr., New York.
For page see List of Advertisers.

Young & Nugent, 42 W. 28th St., N. Y.
For page see List of Advertisers.

Mills the Florist, Jacksonville, Fla.
Telegraph or mail orders promptly filled.
Long distance telephone connections.

NEW AND RARE PLANTS

Rose Hill Nurseries, New Rochelle, N. Y.
For page see List of Advertisers.

NICO-FUME

Kentucky Tobacco Product Co.,
Louisville, Ky.
For page see List of Advertisers.

NURSERY STOCK

John Waterer & Sons, Ltd.,
American Nursery, Bagshot, England.
For page see List of Advertisers.

New England Nurseries, Bedford, Mass.
Shrubs, Roses and Herbaceous Perennials.
Specimen Pyramidal Box.
For page see List of Advertisers.

The Conard & Jones Co., West Grove, Pa.
Hardy Stock.
For page see List of Advertisers.

NURSERY STOCK - Continued

Bay State Nurseries, N. Abington, Mass.
Herbaceous Perennials, Hardy Ornamental
Trees.

For page see List of Advertisers.

Cleary's Horticultural Co., 62 Vesey St.,
New York.
For page see List of Advertisers.

P. Ouwkerk, 216 Jane St., Weehawken
Heights, N. J.
Holland Nursery Stock for Forclog.
For page see List of Advertisers.

Nursery Stock. N. F. McCarthy & Co.,
84 Hawley St., Boston, Mass.

ORCHID PLANTS

Lager & Hurrell, Summit, N. J.
For page see List of Advertisers.

Sander, St. Albans, England.
Importers, Exporters, Growers, Hybridists
For page see List of Advertisers.

Julius Roehrs Co., Rutherford, N. J.
For page see List of Advertisers.

Carrillo & Baldwin, Secaucus, N. J.
For page see List of Advertisers.

Jos. A. Manda, 191 Valley Road, W.
Orange, N. J.
For page see List of Advertisers.

Ordenez Bros., Madison, N. J., Box 105.
For page see List of Advertisers.

PALMS

A. Leuthy & Co., Perkins St. Nurseries,
Rosindale, Mass.
For page see List of Advertisers.

Kentia, Phoenix, etc., all sizes. Write
for new price list. Julius Roehrs Co.,
Rutherford, N. J.

PAINT AND PUTTY

PAINT AND PUTTY: Ideal Greenhouse
lead; Special Greenhouse Putty. Lord &
Burnham, 1133 Broadway, N. Y.

PANSY PLANTS.

Choice pansy plants, 50c. per 100; \$4.00
per 1000. Cash. Aug. Zirngel, Need-
ham, Mass.

PATENTS

Siggera & Siggers, Washington, D. C.
For page see List of Advertisers.

PEAT

Orchid peat, Rotted peat, Azalea peat,
Leaf-Mould, Live Sphagnum moss, Baled
Sphagnum moss, Green Clump moss, etc.
Jobbers' list on application. C. W. Brown-
ell & Co., Walden, N. Y.

PIPE AND FITTINGS

Foley Mfg. Co., between Western Ave. and
26th St., Chicago, Ill.

PIPE AND FITTINGS. Cast Iron and
Wrought Pipe, Valves, Elbows, Pipe Hooks,
Automatic Air Headers, etc. Lord &
Burnham, 1133 Broadway, N. Y.

PLANT BED CLOTH

Mineralized Rubber Co., 18 Cliff St., N. Y.
For page see List of Advertisers.

POT HANGERS

Pot hangers, Kramer's \$1 doz. by exp.,
\$1.25 by mail. I. N. Kramer & Son, Cedar
Rapids, Ia.

PRUNING SHEARS

Rhodes Mfg. Co., Grand Rapids, Mich.
Dept. R.
For page see List of Advertisers.

PYRIMIDAL BOX

Bay State Nurseries, N. Abington, Mass.
For page see List of Advertisers.

RAFFIA

Samples free. Large assortment of
colors. R. H. Comey Co., Camden, N. J.,
or, 910-824 Washburn Ave., Chicago.

We Have It.

Send for New Illustrated Catalogue.
H. Bayersdorfer & Co.,
1129 Arch St., Philadelphia, Pa.

For List of Advertisers See Page 24

RHODODENDRONS

John Waterer & Sons, Ltd.,
American Nursery, Bagshot, England.
For page see List of Advertisers.

ROSES

Thomas Roland, Nahant, Mass.
Lady Gay Rcscs.
For page see List of Advertisers.

Julius Roehrs Co., Rutherford, N. J.
Rambler Rose, Newport Falry.
For page see List of Advertisers.

New England Nurseries, Inc., Bedford,
Mass.
Roses for Forcing.
For page see List of Advertisers.

Bay State Nurseries, N. Abington, Mass.
For page see List of Advertisers.

Bobbinck & Atkins, Rutherford, N. J.
For page see List of Advertisers.

400 varieties; own roots; summer grown.
Leedle Company, Springfield, Ohio.

Low-budded roses. No. 1, \$95.00; No.
1-2, \$65.00 1000. H. T. Jones, Elizabeth,
N. J.

Crimson Ramblers, extra strong, 3-yr.,
for forcing, at 9 cts. Gilbert Costich,
Rochester, N. Y.

The beautiful new pink rose, MISS
KATE MOULTON is the queen of all
pink roses. It's a winner and you should
grow it. Price \$30.00 100; 500 \$125.00;
1000 \$200.00; 5000 and upwards \$175 per
1000. Minneapolis Floral Co., Minneapolis,
Minn.

SCALECIDES

B. G. Pratt Co., 11 Broadway, New York.
For page see List of Advertisers.

SEEDS

T. J. Grey Co., 32 So. Market St.,
Boston, Mass.
For page see List of Advertisers.

Joseph Breck & Sons,
51 and 52 N. Market St., Boston, Mass.
For page see List of Advertisers.

W. Atlee Berpee & Co., Philadelphia.
For page see List of Advertisers.

J. M. Thorburn & Co., 33 Barclay St., N. Y.
For page see List of Advertisers.

A. T. Boddington, 342 W. 14th St., N. Y.
Vinca Seed.
For page see List of Advertisers.

H. F. Mitchell Co., 1017 Market St., Phila.
For page see List of Advertisers.

James Vick's Sons, Rochester, N. Y.
Vick's Superb Pansy Seed.
For page see List of Advertisers.

Hjalmar Hartmann & Co.,
12 Stormgade, Copenhagen, Denmark.
Canliflower and Cabbage Seed.
For page see List of Advertisers.

Richards Bros., 37 E. 19th St., New York.
For page see List of Advertisers.

R. & J. Furquhar & Co., 6-7 So. Market
St., Boston.
Glant Cyclamen Seed.
For page see List of Advertisers.

C. C. Morse & Co., 48-56 Jackson St.,
San Francisco, Cal.
For page see List of Advertisers.

H. E. Fiske Seed Co., Faneuil Hall Sq.,
Boston.
For page see List of Advertisers.

Braslin Seed Growers Co., San Jose, Cal.
For page see List of Advertisers.

O. V. Zangen, Hoboken, N. J.
For page see List of Advertisers.

W. E. Marshall & Co., 146 W. 23d St.,
New York.
For page see List of Advertisers.

R. Wiboltt, Nakskov, Denmark.
Snowball Canliflower Seed.
For page see List of Advertisers.

SMILAX

E. A. Beaven, Evergreen, Ala.
Southern Wild Smilax; Log Mosses.
For page see List of Advertisers.

SPHAGNUM MOSS

Live Sphagnum moss, orchid peat and
orchid baskets always on hand. Lager &
Hurrell, Summit, N. I.

We Have It.
Send for New Illustrated Catalogue.
H. Bayersdorfer & Co.,
1129 Arch St., Philadelphia, Pa.

Fresh, clean, 5 bbl. bale, \$1.25; 2 bales,
\$2.25; 5 bales, \$5.00; 10 bales, \$9.50. Cash.
H. R. Akers, Chatsworth, N. J.

SPIREA

Spirea, extra fine clumps in leading variety.
F. W. O. Schmitz, Pritchard Bay, N. Y.

STEAM TRAP

E. Hippard, Youngstown, O.
For page see List of Advertisers.

VENTILATING APPARATUS

Pierson U-Bar Co., 1 Madison Sq., N. Y.
For page see List of Advertisers.

Hitchinga & Co., 1170 Broadway, N. Y.
For page see List of Advertisers.

Foley Mfg. Co., between Western Ave. and
26th St., Chicago, Ill.
For page see List of Advertisers.

John A. Payne, 260-274 Culver Ave., Jersey
City, N. J.
For page see List of Advertisers.

VENTILATING MACHINERY, New
Model encased, self-oiling gear; Standard
Model Open Gear. Lord & Burnham, 1133
Broadway, N. Y.

WIREWORK

Reed & Keller, 122 W. 25th St., N. Y.
For page see List of Advertisers.

Wirework. Write for our catalogue.
Holton & Hunkel Co., Milwaukee, Wis.

William E. Hellscher's Wire Works, 38-40
Broadway, Detroit, Mich.

The "Just Right" kind. Send for price
list. Frank W. Ball, 31 East Third Street,
Cincinnati, O.

We Have Them.
Send for New Illustrated Catalogue.
H. Bayersdorfer & Co.,
1129 Arch St., Philadelphia, Pa.

**WHOLESALE FLORISTS
Boston**

N. F. McCarthy & Co., 84 Hawley St.,
Boston.
For page see List of Advertisers.

H. M. Robinson & Co., 15 Province St.
and 9 Chapman Pl., Boston.
For page see List of Advertisers.

Welch Bros., 226 Devonshire St., Boston.
For page see List of Advertisers.

Buffalo

Wm. F. Kasting Co., 383-87 Ellcott St.,
Buffalo, N. Y.
For page see List of Advertisers.

Chicago

Chas. W. McKellar, 51 Wabash Ave.,
Chicago.
For page see List of Advertisers.

Peter Reinberg, 51 Wabash Ave., Chicago.
For page see List of Advertisers.

E. F. Winterson Co., 45-49 Wabash Ave.,
Chicago.
For page see List of Advertisers.

Detroit

Michigan Cut Flower Exchange, 38 and 40
Broadway, Detroit, Mich.
For page see List of Advertisers.

**WHOLESALE FLORISTS—
Continued
New York**

J. K. Allen, 106 W. 28th St., New York.
For page see List of Advertisers.

J. S. Fenrich, 110 W. 28th St., New York.
For page see List of Advertisers.

Ford Bios., 48 W. 28th St., New York.
For page see List of Advertisers.

H. E. Froment, 57 W. 28th St., New York.
For page see List of Advertisers.

Alex. J. Guttman, 43 W. 28th St., New
York.
For page see List of Advertisers.

E. C. Horan, 55 W. 28th St., New York.
For page see List of Advertisers.

A. H. Langjahr, 55 W. 28th St., New York.
For page see List of Advertisers.

James McMann, 42 W. 28th St., New York.
For page see List of Advertisers.

Chas Millang, 50 W. 29th St., New York.
For page see List of Advertisers.

John I. Raynor, 49 W. 28th St., New York.
For page see List of Advertisers.

W. F. Sheridan, 39 W. 28th St., New York.
For page see List of Advertisers.

Traendly & Schenck, 44 W. 28th St., New
York.
For page see List of Advertisers.

John Young, 51 W. 28th St., New York.
For page see List of Advertisers.

Moore, Hentz & Naah, 55 and 57 W. 26th
St., New York.
For page see List of Advertisers.

Frank S. Hicka & Co., 52 W. 28th St.,
New York.
For page see List of Advertisers.

Frank Millang, 57 W. 26th St., New York.
For page see List of Advertisers.

Wm. H. Kuebler, 28 Willoughby St.,
Brooklyn, N. Y.
For page see List of Advertisers.

Phillip F. Kessler, 55 and 57 W. 26th St.,
New York.
For page see List of Advertisers.

A. Moltz, 55-57 W. 26th St., New York.
For page see List of Advertisers.

B. S. Shau, Jr., 55 W. 26th St., New York.
For page see List of Advertisers.

A. L. Young & Co., 54 W. 28th St., New
York.
For page see List of Advertisers.

Philadelphia

W. E. McKissick, 1221 Filbert St., Phila-
delphia, Pa.
For page see List of Advertisers.

Leo Nlessen Co., 1209 Arch St., Philadel-
phia, Pa.
For page see List of Advertisers.

The S. S. Peacock-Meehan Co., 1608-18
Ludlow St., Philadelphia, Pa.
For page see List of Advertisers.

Edward Reid, 1526 Ranstead St., Phila-
delphia, Pa.
For page see List of Advertisers.

A. M. Campbell, 1510 Sansom St.,
Philadelphia.
For page see List of Advertisers.

Wm. J. Baker, South Penn. Square,
Philadelphia, Pa.

Pittsburg

J. B. Murdoch & Co., 545 Liberty St.,
Pittsburgh, Pa.
For page see List of Advertisers.

San Francisco

Alex. Maon, Jr., Co., 1125 Polk St., San
Francisco, Cal.
For page see List of Advertisers.

St. Louis

H. G. Berning, 1402 Pine St., St. Louis, Mo.
For page see List of Advertisers.

WHOLESALE PLANTSMAN

Samuel A. Woodrow, 53 W. 30th St.,
New York.
For page see List of Advertisers.

In writing to Advertisers kindly mention Horticulture

List of Advertisers

Page	Page
Allen J. K. 1	McMann Jas. 11
American Nursery... 1	Metropolitan Ma- 27
Aschmann Godfrey... 1	Michell H. F. Co. 20
Atlanta Floral Co. 1	Michigan Cut Flower 19
Barrows H. H. & Son. 1	Exchange. 19
Baur Floral Co. 1	Millang Charles 19
Bayersdorfer H. & Co. 26	Millang Frank. 19
Bay State Nurseries... 4	Mineralized Rubber 26
Beaven E. A. 14	Co. 26
Berning H. G. 17	Moltz, A. 20
Bobbin & Atkins 4	Moninger J. C. 27
Boddington A. T. 11	Moore, Hentz & Nash 19
Boston Florist Letter 4	Moore, J. L. 2
Co. 24	Morse C. C. & Co. 11
Boston Plate and Win- 20	Murdoch J. B. & Co. 10
dow Glass Co. 20	Murray Samuel 15
Bosch, Felix. 20	New England Nur- 3
Braslan Seed Growers 11	series. 3
Co. 11	Nicomie Mfg. Co. 26
Breck Joseph & Sons 11	Niessen Leo. Co. 16
Breitmeyer's J. Sons 15	Ordonez Bros. 13
Bridgemoor's Seed 11	Ouwkerk P. 3
Warehouse 11	Paletorpe P. R. Co. 26
Burpee W. A. & Co. 11	Park Floral Co. 15
Carrillo & Baldwin ... 15	Payne John A. 20
Cassidy I. 27	Peacock-Meehan Co. 2
Chicago Carnation 2	Perfection Chemical 26
Co. 2	Co. 26
Clarke's David, Sons 15	Perkins St. Nurseries. 4
Cleary's Horticultural 19	Pierson A. N. 2
Co. 19	Pierson F. R. Co. 2
Conard & Jones Co. 3	Pierson U Bar Co. 28
Cooke G. H. 15	Pratt B. G. Co. 25
Cowee A. 2	Pritchard J. N. 14
Davis A. B. 2	Pulverized Manure 26
Donohoe W. H. 15	Co. 26
Dorner F. Sons & Co. 16	Rawson W. W. & Co. 26
Dreier H. A. 25	Raynor John L. 18
Dysart R. J. 16	Reed & Keller. 19
Edgar, W. W. Co. 16	Reid Edw. 16
Edwards Folding Box 10	Reinberg Peter. 16
Co. 10	Rhodes Mfg. Co. 27
Elliott Wm. & Sons. 11	Rickards Bros. 11
Erringer, J. W. 27	Robinson H. M. & Co. 14-16
Esler J. G. 27	Rock Wm. L. Flo. Co. 15
Ernest W. H. 27	Roehrs Julius Co. 3-13
Eyres. 15	Roland, Thomas. 3
Farquhar R. & J. & 11	Rolker August & Sons 13-27
Co. 11	Rose Hill Nurseries. 3
Fenrich J. S. 18	Rusconi D. 14
Fiske, H. E. Seed Co. 11	Sander & Son. 4-13
Foley Mfg. Co. 27	Scheepers John & Co. 4
Ford Bros. 15	Schultheis Anton 4
Froment H. E. 8	Schulz Jacob. 3-15
Galvin Thos. F. 15	Scott, John. 13
Garnsey M. V. 15	Sheridan W. F. 19
Grey T. J. Co. 15	Shinn Warren. 10
Gude Bros. Co. 15	Siggers & Siggers. 25
Groves, Robt. 14	Situations & Wants. 21
Guttman Alex. J. 17	Skudelsky S. S. 2
Hall Asso. 27	Slun B. S. Jr. 12
Haines, J. E. 7	Smith Nathan & Son 2
Hartmann Hjalmar & 15	Smyth Wm. J. 15
Co. 15	Standard Plate Glass 27
Hauswirth P. J. 15	Co. 27
Herbert David & Son. 15	Stearns A. T. Lumber 27
Hews A. H. & Co. 17	Co. 27
Hicks Frank S. & Co. 16	Stumpp & Walter Co. 11
Hilfinger Bros. 17	Thorburn J. M. & Co. 11
Hippard E. 27	Totty Chas. H. 2
Hitchings & Co. 25	Traendly & Schenck. 18
Hoffman. 15	Valentine, J. A. 15
Horan E. C. 17	Velthuys, K. 10
Houghton & Clark. 15	Vick's Jas. Sons 11
Kasting W. F. 19	Vincent R. Jr. & Sons. 13
Kentucky Tobacco 17	Warendorf A. 15
Product Co. 17	Waterer John & Sons. 3
Kervan Co., The. 17	Weber F. C. 15
Kessler, P. F. 17	Weber H. & Sons. 2
Kimbley Frank H. 17	Welch Bros. 10
King Cons. Co. 17	Wiboltz, R. 10
Koral Mfg. Co. 24	Wilson. 15
Kuebler Wm H. 19	Wilson, Andrew. 25
Lager & Hurrell 19	Winterson, E. F. Co. 16
Laagjahr, Alfred H. 18	Woodrow, Sam'l A. 19
Lehman Bros. 17	Yokohama Nursery 14
Leuthy A. & Co. 17	Co. 14
Lord & Burnham Co. 28	Young A. L. 19
Manda Jos. A. 11	Young John. 18
Mann, Alex. Jr. Co. 19	Young, Thos. Jr. 15
Marshall, W. F. 19	Young & Nugent. 15
Maxfield & Diamond. 2	Zangen O. V. 11
McCarthy N. F. & Co. 15	Zinn, J. A. 15
McConnell Alex. 15	
McKellar Charles W. 19	
McKissick, W. E. 19	

New Offers in This Issue.

CATALOGUE OF NEW CHRYSANTHEMUMS, ROSES, ETC.

Charles H. Totty, Madison, N. J.
For page see List of Advertisers.

CHANGE OF NAME.

Elmer D. Smith & Co., Adrian, Mich.
For page see List of Advertisers.

COCOS WEDDELIANA SEED.

Sunder & Son, Bruges, Belgium.
For page see List of Advertisers.

GRAFTED AND OWN ROOT ROSES.

A. N. Pierson, Cromwell, Conn.
For page see List of Advertisers.

LILIUM AURATUM, ROSEUM, MULTIFLORUM.

D. Rusconi, 128 W. 6th St., Cincinnati, O.
For page see List of Advertisers.

RHUBARB ROOTS: ASPARAGUS ROOTS AND SEED.

Warren Shinn, Woodstown, N. J.
For page see List of Advertisers.

WAGON HEATER.

Lehman Bros., 10 Bond St., New York.
For page see List of Advertisers.

WHITE ENCHANTRESS ROOTED CUTTINGS.

Jacob Schulz, 644 4th Av., Louisville, Ky.
For page see List of Advertisers.

WHOLESALE SEED CATALOGUE.

J. M. Thorburn & Co., 33 Barclay St., New York.
For page see List of Advertisers.

WINSOR AND WHITE ENCHANTRESS ROOTED CUTTINGS.

The F. R. Pierson Co., Tarrytown-on-Hudson, N. Y.
For page see List of Advertisers.

WANTS, FOR SALE, ETC.
Advertisements in this column one cent a word. Initials count as words. Cash with order. All correspondence addressed "care HORTICULTURE" should be sent to 11 Hamilton Place, Boston.

SITUATIONS WANTED

WANTED Position with reliable wholesale or retail seed house as seedman; six years' experience with trustworthy seed firms; nationality, Scotch. Address Seeds, care Horticulture.

WANTED Situation by A1 grower of carnations, violets and bedding stock; best of references. J. P. Hersey, 724 South St., Roslindale, Mass.

SITUATION WANTED in general greenhouse work; single, age 35, five years' experience, commercial. Address W. W., care HORTICULTURE.

FOR SALE

Suburban Florist Store FOR SALE CHEAP

Fine location for local trade; two years established. Fitted with ice chest, counters, etc., for immediate occupancy. A good chance for industrious party.

Address C Care Horticulture, Boston.

FOR SALE—A large consignment of 16x24 double thick American glass, A and B quality. For further information write Parschelsky Brothers, 59 Montrose Avenue, Brooklyn, N. Y.

FOR SALE—Greenhouses 5,000 feet, heavily stocked, nearly new, flourishing trade. A bargain, \$1,600. Reason for selling, other business. Knoll Floral Co., Pierceton, Ind.

FOR SALE—2000 feet second-hand 4-inch cast iron pipe with fittings. In perfect condition. Apply to T., care Horticulture Pub. Co.

FOR SALE—Cheap for cash, five-foot horizontal tubular boiler, complete, good as new. G. S. Rainsburg, Somersworth, N. H.

STORAGE COMPANY MUST PAY.

Lily Pips Sprouted in Freezer—Court Holds That Refrigerating Company Must Keep Temperatures Sufficiently Low to Preserve the Goods.

Julius Roehrs' exotic nurseries of Rutherford, New Jersey, will celebrate the present holiday season with a check for over five thousand dollars (\$5000), recovered through its attorneys, Hatch & Clute, of 100 Broadway, New York, in a law suit which involved points of great importance to florists and cold storage men.

The decision in favor of Mr. Roehrs has just been unanimously affirmed on appeal by the Appellate Division of the Supreme Court in New York, and the substantial sum of money turned over by the storage house to make good the loss caused by the sprouting of the pips.

It appears from the record on the appeal in the case, that in the winter of 1903-04 Mr. Roehrs received about a million lily of the valley pips from well-known German florists. He used about half of the pips in question at his nurseries in Rutherford, N. J., during the winter of 1903, and about the middle of March, 1904, he stored the remaining half million pips with the Manhattan Cold Storage Company, of New York. The following summer Mr. Roehrs discovered that the pips while in the storage warehouse had sprouted and were growing. He immediately caused an investigation to be made by his lawyers, who represent a number of local florists and who have given special attention to the legal rights of the trade in the matter of the very heavy losses which have been sustained through the careless storage of goods. As a result of this investigation the demand was made upon the storage company to reimburse Mr. Roehrs for the loss of the pips, and this demand brought about a test of the respective rights of the florist and the storage house under the circumstances disclosed.

It was claimed, on behalf of the storage company, that its legal obligation was not to "preserve the goods," in the absence of a special agreement for a specific temperature, and that, as Mr. Roehrs could not establish what occurred in the storage warehouse, he could not recover. It was also claimed that the condition of the goods at the time they were received from Europe, as well as their condition at the time they were stored, was in doubt, because not all of the boxes were examined at Mr. Roehrs' place.

So important were these points to the trade generally, that Mr. Roehrs determined to fight the case to the end, and on the trial many well-known florists and growers of Lily of the Valley testified as witnesses. Mr. Roehrs' attorneys succeeded in getting before the jury the temperature records of the storage company, which contained some damaging evidence in the way of temperature, which experts said were too high to preserve the bulbs. It was also shown that the goods of several other dealers stored there during the same period were found to have sprouted. Expert storage men were brought from Philadelphia and other cities, who testified that the storage plant of the defendant was constructed according to the most

Is Your Name In The Above List? If Not, Why Not?

modern plans and was equipped with a proved refrigerating machinery; but there was strong substantial evidence offered, to establish some special carelessness and oversight on the part of the storage company, during the spring of the year in question. A sufficient rise in temperature was indicated to start the bulbs from their dormant state, and it was proved by the testimony of experts, that when once the pips had sprouted, their growth could not be stopped or retarded without destroying them. This evidence convinced the jury, which decided in favor of Mr. Roehrs, and they brought in a verdict for the full value of the goods. The court ruled against the storage company, on the point which was made by its lawyers, that all of the boxes of the goods should have been opened and examined by the florist before the goods were placed on storage. The court sustained the contention that only a reasonable examination, in ordinary course of business, is necessary.

It is needless to say that the defendant storage company, and other companies in the same line, will take special notice of this case, in the future conduct of their business, and it is also apparent that the decision will attract much attention from florists, who cannot fail to benefit largely by the protection which this decision affords them.

THE POTATO.

A paper read before the Southampton Horticultural Society by Walter L. Jagger.

If in the presentation of this paper the personal pronoun I is prominently presented I trust you will not think it to be in a spirit of egotism. When nine years old I was called upon to assist in the planting and culture of potatoes and have been at it every year since, so that I may justly claim to have been a grower of the *Solanum tuberosum*, for more than half a century and yet at the present time feel that I can only lay claim to a hack seat among the army of potato growers who are making a financial success of the business. The tools used for planting when I began consisted of a plow and manure fork only, and for tilling this same plow, a small harrow and a hoe; this hoe was usually manipulated by the boy and in most cases was in size all out of proportion to his strength. Plowing 4 rows, 40 rods long, was considered a fair day's work. The only recreation we could get was to exchange work with the neighbor's boy over the pond; you help me hoe two rows and I'll help you hoe two; the work went more easily when we had companionship. My father was one of the very first in this locality to purchase a horse hoe cultivator and this tool at that time did very efficient work. It is still in existence in my tool house, but its use has long since been superseded by better ones and it is only kept as a reminder of the past.

In the season of 1867 potatoes nearly all rotted, and there were not enough produced in the locality to supply the demand. Many had to substitute turnips and the cereals. My father, who was something of an experimenter, had this year eight rows, 40



"SCALECIDE"

SAVE YOUR TREES THIS FALL DON'T WAIT TILL SPRING

ORDER
A
BARREL
NOW

The chances are they'll be killed by San Jose Scale. Take time by the forelock—spray with **SCALECIDE**. It kills every insect it touches. Cheaper than Lime-Sulphur or any home-made mixture, and easier to apply. Non corrosive, non-clogging, 32 percent oil—the largest amount with less water than is found in any spray yet discovered. We prove it. Order a 50-gallon barrel at \$25. Makes 800 or 1000 gallons costing 25c to 30c at any station in the U. S. east of Mississippi and north of Ohio Rivers. There's nothing cheaper. Send now for free, special booklet W.

B. G. PRATT CO., Mfg. Chemists,
11 Broadway, New York City

rods long, planted with seaweed in the drill, and these produced enough to supply the family with potatoes. The balance of the field all rotted and were not worth digging. I have often wondered whether salt might not help prevent rot in potatoes. The chemical fertilizers of the present day had not then come on the market. Peruvian guano, ground bone, fish lime, wood ashes, mock farm manure, were used in different combinations and proportions, and the process of planting an acre of potatoes was a laborious one.

After coming into possession of a farm of my own I spent a good deal of time and money experimenting with different varieties of potatoes. One year I grew 13 varieties, some of which were almost a total failure, entailing on me quite a money loss. It took me quite a number of years to find out which was the most profitable variety for me to grow, and after a time I learned it was a great deal cheaper to let the other fellow do most of the experimenting and confine myself to growing one variety which yielded well and found a ready market, which at the present time appears to be Carman No. 1.

I grew one year on a measured acre 396 bushels of marketable potatoes and 10 1-2 bushels of culls, making a total yield of 406 1-2 bushels on the acre. The variety was the Early Norther. I never had any such yield before nor since. I made no special effort to grow this acre of potatoes, but like Topsy they "just grew."

For the years 1897, '98, '99, 1900, I had charge of three acres under the direction of Dr. Jordan, director of the New York Agricultural Experiment Station, at Geneva. These three acres were divided into ten parts each, making 30 plats in all, and the objects were: First, a comparison of different amounts of complete fertilizer from 500 to 2,000 pounds; second, a test of the relative efficiency of the common Long Island formula 4-8-10 mixture and a fertilizer based on the composition of the potatoes, a 7-4-10 mixture; third, the use side by side of sulphate and muriate as a source of potash; fourth, a comparison of formula containing 10 per cent potash with the same mixture in which the potash was reduced to two-thirds, one-third and nothing. The materials used in compounding all the fertilizers were citrate of soda, dried blood, acid phosphate, sulphate or muriate of potash and land plaster.

I will not at this time enter into details as to results; suffice it to say that the experiments appeared to prove that 1,500 pounds was the limit of profitable application. The 4-8-10 mixture gave better results than the formula based on the supposed draft of the potatoes

on the soil. The tests of muriatic and sulphate were not conclusive and the surprising thing was, notwithstanding the large quantity of potash taken from the soil by the potato tubers, 30 pounds in 100 bushels, the crops in these tests seemed to find a sufficient supply of this element in the natural soil, for the plats receiving only nitrogen and phosphoric acid averaged slightly more than those receiving one-third or two-thirds of the full amount of potash per acre, and only a fraction of a bushel less than that receiving the entire amount.

The composition of the tubers evidently varies according to seasons and soils and fertilizers, the variety grown, etc. I suppose you all have noticed that some seasons potatoes cook better and have a better flavor than at others. It is claimed that sulphate of potash produces a finer quality of starch than muriate, but from my observation and experience I am inclined to think that soil, season and variety have fully as much to do with the composition of the potatoes as the kind of fertilizers used. Albert Carman, former editor of the Rural New Yorker, the originator of several varieties of potatoes, has to my mind done as much or more for the benefit of the people of this country than Luther Burbank with all the plants and flowers which he has originated, though if my memory serves me right, the Burbank potato was one of those used by Mr. Carman in crossing to produce the ones he did. Understand me, I do not intend in the least to disparage the work of Mr. Burbank; he has wrought wonders and a history of his creations in plant life is as fascinating as a novel.

PATENTS

Trademarks and Copyrights

Send other business direct to Washington. Saves time and insures better service. Personal attention guaranteed. Twenty-five years' active service. SPECIALTY: "Working on the Failures of Others."

SIGGERS & SIGGERS

PATENT LAWYERS

Box 9, National Union Building
Washington, D. C.

Holds Glass Firmly

See the Points **PEERLESS**

Glassing Points are the best 80 rights or lefts. Box of 1,000 points 75 cts. postpaid.

HENRY A. DREER,

714 Chestnut St., Phila., Pa.

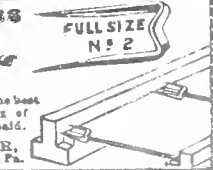

Tobacco Paper "NICO-FUME" LIQUID
 S THE
STRONGEST,
BEST PACKED,
EASIEST APPLIED.
 24 sheets.....\$ 0.75
 144 sheets..... 3.50
 288 sheets..... 6.50
 1728 sheets..... 35.10

**Furnishes the
 Most Nicotine for the Money!**

... Manufactured by ...
 THE KENTUCKY TOBACCO PRODUCT CO., Louisville, Ky.

OVER 40% NICOTINE
 By far the
CHEAPEST.
 JUST NOTE PRICES!
 Pint.....\$ 1.50
 1/2 Gallon..... 5.50
 Gallon..... 10.50
 5 Gallons..... 47.25

WILSON'S PLANT OIL

If you want to make money there is only one way. That is to have clean stock and the only way to get it is by using WILSON'S PLANT OIL.

New York Botanical Garden, Bronx Park, New York City, September 5, 1906.
 Mr. Andrew Wilson—Having used your insecticide here, I can testify to its efficiency in destroying scale and other insects infesting plants.
 Yours very truly,
 GEO. A. SKENE.

Florham Farms, Madison, N. J., December 8, 1906.
 Mr. Andrew Wilson:—Dear Sir—Your Plant Oil is certainly the most effective scale killer I have ever tried. Please send another five gallons.
 Yours truly,
 A. HERRINGTON.

PRICES: 1-2 pint cans, 25c; pints, 40c; quart, 75c; 2 quarts, \$1.25; gallon, \$2.00; five gallons, \$9.00. Cash with order.

ANDREW WILSON, Dept. 8, SUMMIT, N. J.
 Selling Agents for New England, R. & J. FARQUHAR & CO., 6 and 7 South Market St., Boston, Mass.

**GREENHOUSES BUILDING OR CON-
 TEMPLATED.**

Bryn Mawr, Pa.—J. C. Bright, house 11x19.
 Fitzgerald, Ga.—Joel Thomas, house 16x70.
 Atchinson, Kan.—Edward Snell, addition.
 Canajoharie, N. Y.—Jos. Trandt, one house.
 E. Bethel, Vt.—Aaron Storrs, one house.
 Thompsonville, Ct.—C. F. Brainard, one house.
 Rutland, Vt.—Baker's Seed House, house 22x102.
 Jamestown, O.—D. E. Adsit, three houses each 20x80.
 Westery, R. I.—S. J. Renter & Son, six houses each 35x185.
 Franklin, Mass.—Continental Nurseries, one house 30x300.

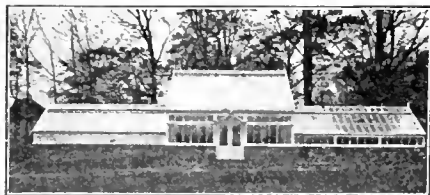

**I MANUFACTURE
 AND ERECT**

Iron frame and wood Greenhouses of every type for commercial and private use.
 If you contemplate building, allow me to submit sketch and estimate covering your requirements.

JOHN A. PAYNE,
 Horticultural Architect and Builder.
 Main Office and Factory:
 260-274 Culver Ave., Jersey City, N.J.
 Sash opening apparatus and all kinds of greenhouse structural material.

**The Best
 Bug Killer and
 Bloom Saver**

For PROOF
 Write to
P. R. Palethorpe Co.
 OWENSBORO, KY.

NEW HEATING APPARATUS.
 John Cotting, Rock City, N. Y., has installed a new system.
 Baker Seed House, Rutland, Vt., one 40 H. P. boiler.

Look through the Buyers' Directory and Ready Reference Guide. You will find some good offers there also.

ANCHOR GREENHOUSE HOSE
 WEARS WELL.
PLANT BED CLOTH
 Protects from Cold and Dampness.

GARMAN'S ANTIPEST

For the Garden, Orchard and Greenhouse.
 Non-poisonous and harmless to vegetation.
 Kills Green Fly, Aphides, Bark Lice, Thrip, Mealy Bug, Red Spider, Scale, Wire Worms, Ants and Slugs.

This is the Grower's Friend, handy to use, cheap and effective, mixes readily in water. Destroys all insect pests, and keeps down filth. Circulars on application \$1.50 per gallon. Also in quarts, half gallons and in bulk.

PERFECTION CHEMICAL CO.,
 FLUSHING, N. Y.
 Eastern Agents:
W. W. RAWSON & CO., 5 Union St. Boston, Mass.

NIKOTEEN APHIS PUNK
 THE ORIGINAL AND GENUINE
NICOTINE FUMIGANT
 STRONGEST AND MOST UNIFORM
NIKOTEEN
 LIQUID
 FOR SPRAYING OR VAPORIZING
NICOTINE MFG. Co. ST. LOUIS, MO.

MINERALIZED RUBBER CO.
 18 Cliff Street New York

BOSTON PLATE & WINDOW GLASS CO.
GREENHOUSE GLASS
 German and American
 261 to 287 A St., BOSTON 20-22 Canal St.

**Cattle Manure
 In Bags** Shredded or Pulverized

Best and safest manure for florists and greenhouse use, absolutely pure, no waste, no danger. Write for circulars and prices.
 The Pulverized Manure Co.,
 31 Union Stock Yards, Chicago

In ordering goods please add, "I saw it in HORTICULTURE."

GREENHOUSE GLASS

Cheaper Now Than For Years

We are taking contracts for next Spring delivery.

WRITE FOR OUR PRICES

STANDARD PLATE GLASS COMPANY

26-30 Sudbury St. 61-63 Portland St.
BOSTON, MASS.

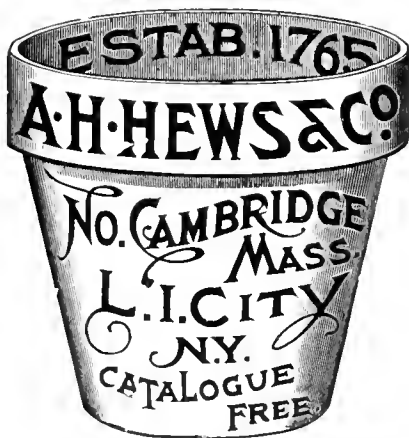

STANDARD FLOWER POTS

Packed in small crates, easy to handle.

Price per crate		Price per crate	
1500 2 1/2 in. pots in crate	\$4.88	120 7 in. pots in crate	\$4.20
1500 2 1/4 " " "	5.25	60 8 " " "	3.00
1500 2 " " "	6.00	HAND MADE	
1000 3 " " "	5.00	48 9 in. pots in crate	\$3.60
800 3 1/2 " " "	5.80	48 10 " " "	4.80
500 4 " " "	4.50	24 11 " " "	3.60
320 5 " " "	4.51	24 12 " " "	4.80
144 6 " " "	3.16	6 16 " " "	4.50

Seed pans, same price as pots. Send for price list of Cylinders for Cut flowers, Hanging Baskets, Lawn Vases, etc. Ten per cent. off for cash with order. Address Hilfinger Bros., Pottery, Fort Edward, N. Y. August Folker & Sons, Agts., 31 Barclay St., N. Y. City.

Standard Flower .. POTS

If your greenhouses are within 500 miles of the Capitol, write us, we can save you money

W. H. ERNEST,

28th and M Street WASHINGTON D. C.

METROPOLITAN MATERIAL CO. GREENHOUSE WRECKERS

Everything in New and Second Hand To

REPAIR HEAT BUILD GREENHOUSES

1398-1408 Metropolitan Ave. BROOKLYN, NEW YORK

In ordering goods please add, "I saw it in HORTICULTURE."

INSURANCE

of your plants from FREEZING in cold weather: at a trifling cost. Use a celebrated

LEHMAN WAGON HEATER

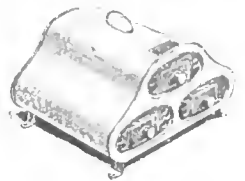

There is no danger of fire; no smoke, dirt or gases to injure plants. They burn Lehman Coal, which costs less than 1/2 cent per hour.

400,000 Lehman heaters are in actual use by Florists, Horsemen, Agriculturists and Physicians. Have you one? Write for new booklet with prices to-day.

LEHMAN BROS.

Manufacturers

10 Bond St., NEW YORK

BEWARE OF IMITATIONS.

J. W. ERRINGER

Gen. West. Sales Agent

45 E. Congress St., CHICAGO

Mention "Horticulture" when writing.

THE STANDARD STEAM TRAP

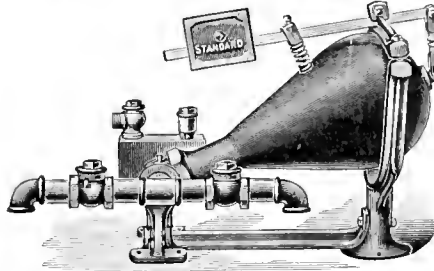

Is acknowledged the best for the florist, because it is durable and does its work without trouble and annoyance, saving its cost by the economy in coal bills.

E. HIPPARD

YOUNGSTOWN, OHIO

NOW IS THE RIGHT TIME TO FIGURE

MATERIAL

AND PLAN FOR THE BUILDINGS OF NEXT YEAR

FOLEY'S

QUALITY AND WORK THE BEST. PRICES RIGHT AND LOWEST. ESTIMATES WILL PROVE. TRY US.

Foley Ventilating Apparatus Unequaled

Will Ventilate any Size of House Easily. Send for Circular.

THE FOLEY MFG. CO. Western Ave. 25th & 26th Sts. CHICAGO

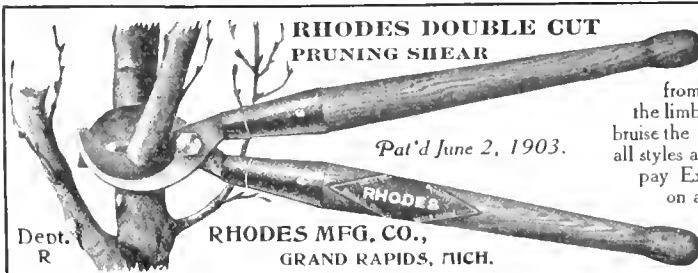

RHODES DOUBLE CUT PRUNING SHEAR

Pat'd June 2, 1903.

Dept. R

RHODES MFG. CO., GRAND RAPIDS, MICH.

THE only pruner made that cuts from both sides of the limb and does not bruise the bark. Made in all styles and sizes. We pay Express charges on all orders. Write for circular and prices.

I. CASSIDY

Designer and Builder OF

Iron and Wood Greenhouses

Office and factory, 215 to 221 Randolph Ave. JERSEY CITY, N. J.

GREENHOUSE CONSTRUCTION LUMBER

John C. Moninger Co.

117 E. Blackhawk St., CHICAGO

R. TONAWANDA, N. Y.

TORONTO, ONT.



CYPRESS SASH BARS

82 feet or longer

HOT BED SASH

PECKY CYPRESS BENCH LUMBER

GREENHOUSES

ERECTED AND EQUIPPED COMPLETE IF DESIRED

Write for Circular "D" and Prices

The A. T. STEARNS LUMBER CO. NEPONSET, BOSTON, MASS.

The FLORISTS' HALL ASSOCIATION OF AMERICA, insurer of 28,000,000 sq. ft. of glass. For particulars address John G. Esler, Sec'y, Saddle River, N. J.

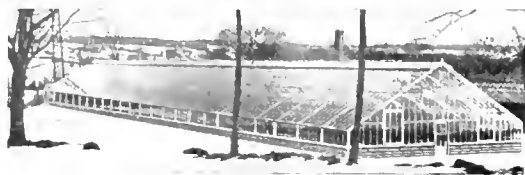

THE NORTH SIDE RESULT of our Steel Eave Plate is what we want you to know. When we say this eave plate of ours clears itself from snow and ice, we are talking particularly about the north side of the house.

This photograph of the north side of this 40 foot Iron Frame house of Mr. Jeff. Doremus, at Madison, N. J., was taken last winter at four o'clock on an afternoon when the mercury was hanging around the below zero mark. *The eave is cleared of ice.*

But don't think the steel eave plate is for the Iron Frame House only — we use it in our Half Iron Construction and are ready to sell you ten or ten hundred feet of it with the roof bar brackets bolted to it. Get the price — and get it now.

HITCHINGS AND CO.

GREENHOUSE DESIGNERS AND BUILDERS.

Manufacturers of Heating and Ventilating Apparatus.

1170 Broadway, NEW YORK.

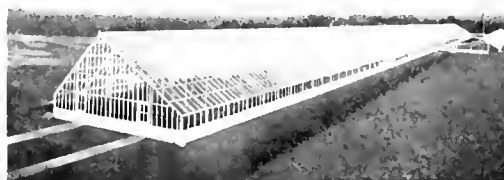

Two Ways the First Cost OF THE Wide House Wins Out

A house 11 feet wide requires identically the same sides, same ridge, same work in setting side posts and putting up the frame, same amount of glass and paint as the 30 foot wide house: so one wide house is not only cheaper to erect, but a very considerably cheaper to maintain, than two narrow houses covering the same space. Don't make the mistake of forgetting the difference between cutting expense down and cutting it off at both ends. The large house cuts both ends — the building end and the maintaining end.

Get your order for a Sectional Iron Frame House in at once so we can make prompt deliveries the first building day in the Spring.

We make every part of a greenhouse but the glass. We sell any part.

LORD & BURNHAM CO.
Greenhouse Designers and Manufacturers

1133 BROADWAY, cor. 26th Street, N. Y.
BOSTON Branch: 819 Tremont Building
PHILADELPHIA Branch: 1215 Filbert St.



These U-Bar greenhouses are the central feature of an extensively laid out ground scheme.



By connecting the potting-house by a 11 feet passage the shading of the central house is overcome and valuable space for propagating benches secured.

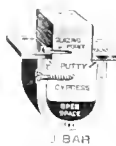

THE owner of this range took unusual pains, time and trouble to investigate thoroughly the merits of the various greenhouse constructions, and placed the order with us only after he had become convinced that the U-Bar construction is greatly superior to any other. Our catalog tells in an interesting way all about the U-Bar construction. Send for it. **Pierson U-Bar Company**, Designers and Builders *U-Bar Greenhouses*, Metropolitan Building, 4th Ave. and 23rd St., New York.

HORTICULTURE

Vol. VII.

JANUARY 11, 1908

No. 2

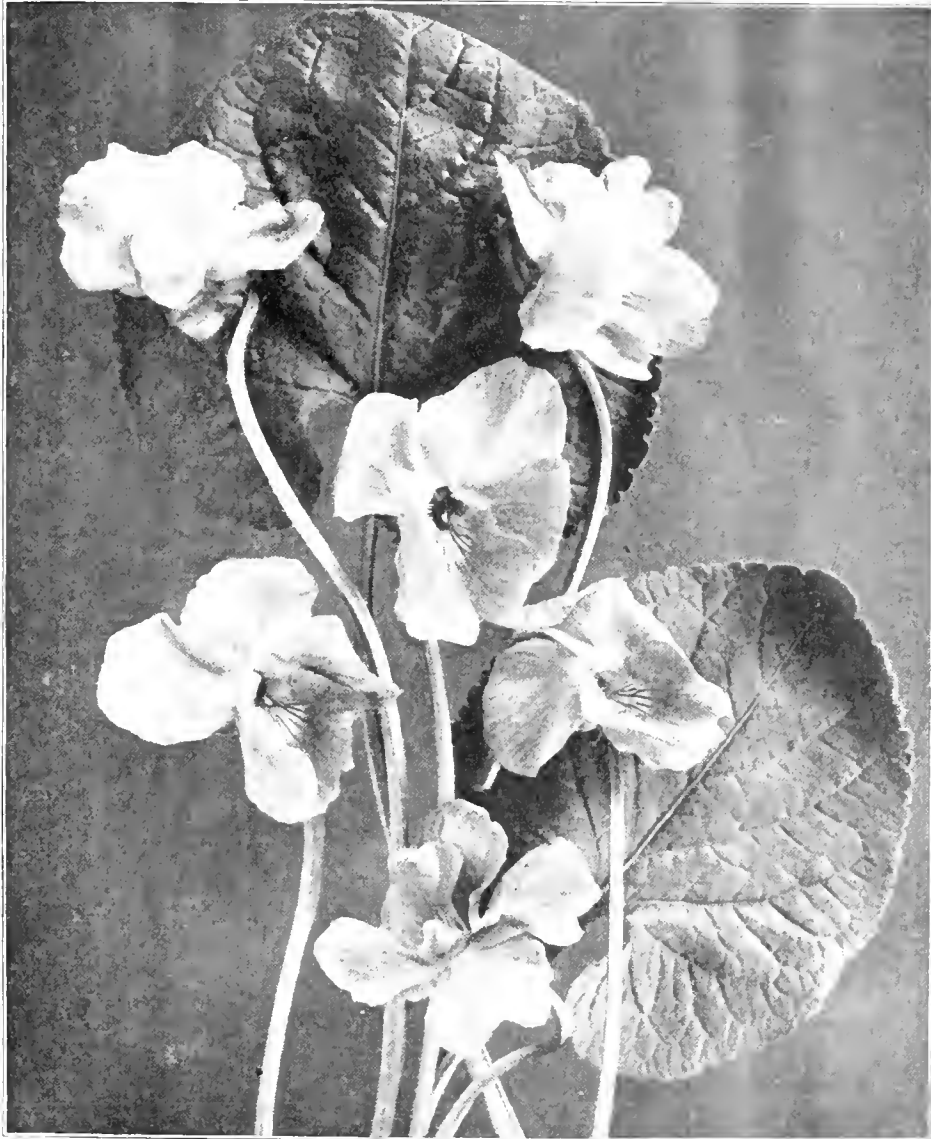

NEW VIOLET "BOSTON"
Reduced One Third

*Devoted to the
FLORIST, PLANTSMAN,
LANDSCAPE GARDENER,
and
Kindred Interests*

*Published
EVERY SATURDAY
At 11 Hamilton Place,
BOSTON, MASS.
Subscription, \$1.00*

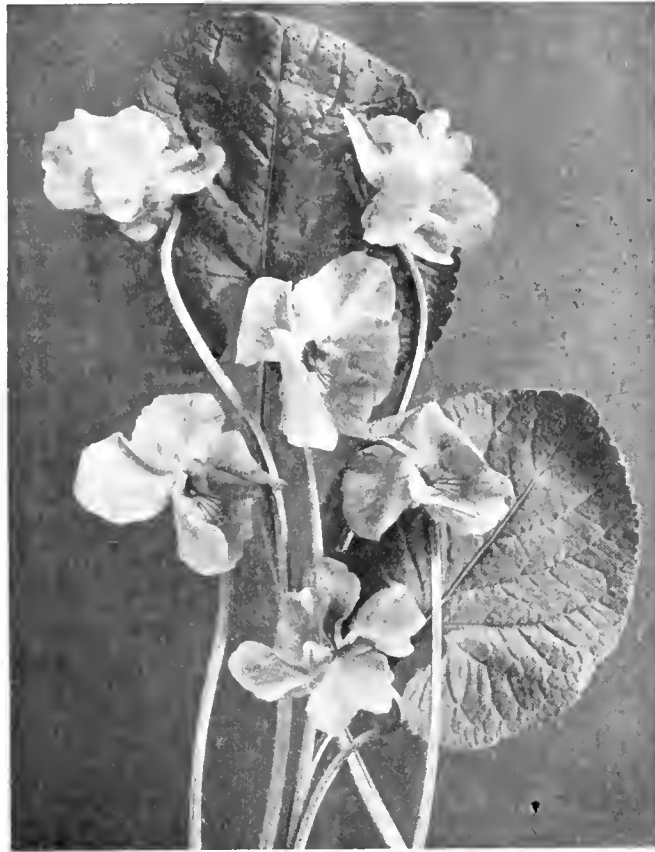

New Violet BOSTON

In introducing this new variety to the trade I wish to state that I have been growing it in quantity for the past two years and do not hesitate to state that it is entirely distinct, a strong grower, a free bloomer, and the finest single Violet in cultivation.

Ready for Distribution in April and May. Orders booked now.

\$1 per 12; \$12 per 100; \$100 per 1000
500 at 1000 rate

WILLIAM SIM
Clifftondale, Mass.

Just Received in Splendid Condition

15,000 AZALEAS

in all sizes and varieties

25c. up to \$2.00 each

Also Kentias, Rubbers, Araucarias, Pandanus, Boxwood, Euonymus, Crotons, Areca and Eurya latifolia.

Extra good value in large

Specimen and Decorative Palms

A. LEUTHY & CO.

Perkins Street Nurseries, Roslindale, Mass.

GERANIUMS

WE have an immense crop of good plants from 2 inch pots, ready for immediate shipment at prices running from \$2.00 per 100 up for good standard sorts. We will send one thousand in twenty varieties, our selection, for \$18.50; five hundred for \$9.25.

ALLIANCE—A Hybrid between a Zonal and an Ivy which has retained all the good points of both parents, the beautiful soft finish of an Ivy and the hardy constitution of the Zonal. Its color is the most exquisite shade of delicate lilac white, feathered and blotched crimson rose, flowers semi-double, habit dwarf, an ideal pot plant in every way. Strong plants from 2 inch pots, \$1.00 per doz., \$6.00 per 100.

IVY GERANIUMS—In good assortment, \$3.00 per 100. We make the special offer for a short time of \$25.00 per 1000, our selection of five kinds, 500 for \$12.50.

CACTUS GERANIUMS \$1.00 per doz., \$8.00 per 1000.

For Dahlia Root and Miscellaneous stock see issue of Dec. 28th. Cash with order.

R. VINCENT, Jr. & SONS CO., - White Marsh, Md.

ANTON SCHULTHEIS

Wholesale Plant Grower,
College Point, - New York.

Price List of Follage, Flowering
and Decorative Plants sent free on
application.

GODFREY ASCHMANN

Importer and Wholesale Grower
and Shipper

of Araucaria Excelsa, Compacta, Robusta and Glauca;
Kentia Forsteriana and Belmoreana Azalea, Indica, etc.
Cultivator of Boston, Scottia, Barrowsii, Elegantissima
and Whitmanii Ferns. Ferns for dishes, Cocos,
etc. Write for prices.

1012 Ontario St., Philadelphia

AZALEAS GHENT-MOLLIS And Natives **PYRAMIDAL BOX** LARGE STOCK All Sizes

ROSES STRONG PLANTS—BEST VARIETIES
Send for List and Prices

Acres of HERBACEOUS PERENNIALS. LARGEST VARIETY IN NEW ENGLAND

Send for Catalogues. **BAY STATE NURSERIES** NO. ABINGTON MASS.

THE FINEST
Lily of the Valley Excellenta

From cold storage. Only few cases left. Please
order at once. \$32.00 per case of 2000 fine pips.

JOHN SCHEEPERS & CO.
4 & 6 Old Slip, - NEW YORK.

LILIUM AURATUM
9-11 \$75 per 1000
ROSEUM and RUBRUM
9-11 \$65 per 1000
MULTIFLORUM
7-9 \$45 per 1000

D. RUSCONI, 128 West 6th St., CINCINNATI, OHIO

SEED—COCOS WEDDELIANA

Specially Splendid Seed
\$4 per 100 \$36 per 1000

Carriage free. Cash from unknown correspondents.

SANDER & SONS, Bruges, Belgium.

AUGUST ROLKER & SONS
Supply the trade with
PLANTS AND BULBS

For greenhouse or outdoor use, imported
to order. Send for estimate. Address—
Barclay St., or P. O. Box 752, New York.



For Easter Forcing

RHODODENDRONS fine plants, shapely bushy specimens with twelve or more buds. **\$1 each; \$11 per doz.; \$90 per 100**

HARDY AZALEA MOLLIS a plant that is becoming more popular every season for forcing, if you have never used it try a few as an experiment. We offer bushy well budded plants 15 in. high. **\$4.50 per doz.; \$35 per 100**

DEUTZIAS FOR FORCING

STRONG, FIELD GROWN PLANTS

LEMOINEI suitable for 6 or 7 in. pots. **85c per doz.; \$6 per 100**

GRACILIS suitable for 6 or 7 in. pots. **85c per doz.; \$6 per 100**

GRACILIS ROSEA suitable for 6 or 7 in. pots. **85c per doz.; \$6 per 100**

For a full and complete list of all reasonable stock see our new **Quarterly Wholesale List** issued January 1st

HENRY A. DREER

714 Chestnut Street, : PHILADELPHIA

Hardy Roses

American Grown—Superior to Imported

We have unsold at the present time the following varieties—all field grown plants, grown in our nurseries at Rochester, N. Y.:

- | | |
|--------------------|-----------------------|
| Anne de Diesbach | Prince Camille |
| Cllo | Thick Branch |
| Frau Karl Druschki | Crimson Rambler |
| General Jacquemlot | White Rambler |
| John Hopper | Yellow Rambler |
| Mme. G. Lulzet | Philadelphia Rambler |
| Marshall P. Wilder | Common Sweet Briar |
| Mrs. John Laing | Mme. G. Brant |
| Paul Neyron | Wichuriana (The Type) |

These plants are in our storage cellars and can be shipped at any time. Prices on request.

ELLWANGER & BARRY

Nurserymen—Horticulturists

Mount Hope Nurseries, Rochester, N. Y.

DAHLIAS.

Now is the time to place your order for bulbs which will insure you getting named varieties in any quantity; prompt delivery.

DAVID HERBERT & SON,

Successors to L. K. Peacock, Inc.

ATCO, N.J.

100,000 DAHLIAS

Premium Stock, guaranteed true to name. 500,000 large Flowering Gladioli, hundreds of colors and variations mixed. Wholesale prices on application. Order now for spring delivery. Catalogue free.

J. L. MOORE, Northboro, Mass.

JOHN SCOTT

Grower of PALMS, FERNS and Other Decorative Stock

NEPHROLEPIS SCOTTII All the Year Round

Rutland Road and East 45th St.

Telephone 2890 Bedford BROOKLYN, N. Y.

NEP. WHITMANI

2 1/4 in., \$5.00 per 100

NEP. WHITMANI

3 1/2 in., \$25.00 per 100

BOSTON FERNS

2 1/4 in., \$3.00 per 100

H. H. BARROWS & SON Whitman, Mass.

John Waterer & Sons, Ltd.

AMERICAN NURSERY

BAGSHOT, ENGLAND

Rhododendrons, Andromedas, Kalmias and Specimen Evergreens

NEW — NEW

RAMBLER ROSE "NEWPORT FAIRY"

To be disseminated Spring, 1908. Ask for illustrated pamphlet and prices

JULIUS ROEHRS CO., Rutherford, N.J.

ROSES

Selected Stock for Forcing **CRIMSON RAMBLER** and **DOROTHY PERKINS**

3 to 4 ft. \$1.50 per 10, \$12.00 per 100; 4 to 5 ft. \$2.00 per 10, \$15.00 per 100

HYBRIDS—All Leading Varieties, \$1.50 per 10, \$12.00 per 100

General Catalog and Trade Lists on Application

The NEW ENGLAND NURSERIES, Inc., Bedford, Mass.

WE are now booking orders for Grafted and Own Root Rose stock.

A. N. PIERSON

CROMWELL, - - - CONN.

Established 40 Years

Rose Hill Nurseries

New and Rare Plants

NEW ROCHELLE, N. Y.

New York Office, Siebrecht Building, 425 Fifth Avenue

Hardy Rhododendrons Azaleas Conifers, Clematis, H. P. Roses, Shrubs and Herbaceous Plants from our

HOLLAND NURSERIES

Prices Moderate

P. OUWERKERK, 216 Jane St. Westhaven Heights P. O. No. 1. Hoboken N. J.

CANNAS

Send for our List and Prices

The CONARD & JONES CO. WEST GROVE, PA.

PRICES QUOTED IN THESE COLUMNS ARE FOR DEALERS ONLY

When Writing to Horticulturist Please Mention Horticulture

WINSOR and WHITE ENCHANTRESS Strong Rooted Cuttings Now Ready For Delivery

WINSOR has proved to be the finest carnation in the light pink class. We sold a large quantity of it last year, but there will be a much larger sale for it this year. At the English Carnation Show held in December, it was the winner in the light pink class. It is doing well everywhere and will supplant everything in that color.

WHITE ENCHANTRESS will occupy the same position among white carnations that Enchantress does among flesh pinks. It has all the good qualities of the common Enchantress,—long stem, earliness, large size, freedom, etc. In our opinion, it is by far the best white carnation ever introduced.

We have a splendid stock of both Winsor and White Enchantress ready for immediate delivery, and will guarantee perfect satisfaction with the cuttings supplied. Do not wait, because the demand for these varieties is bound to be enormous. **Order early, while we can promise immediate delivery**, and secure gilt edged stock. We have a large stock of both of these varieties, and all our cuttings are heel cuttings, taken from flowering stems. On account of the quantity that we are growing, we are not obliged to over-propagate, and our stock is in the most perfect and healthy condition.

Strong rooted cuttings from sand, \$6 per 100, \$50 per 1000. Extra strong transplanted cuttings from soil, \$7.50 per 100, \$60 per 1000. Strong established pot-grown plants \$9 per 100, \$75 per 1000.

F. R. PIERSON CO., - Tarrytown-on-Hudson, - NEW YORK

LLOYD IS THE REAL THING The Carnation for every one to grow

LLOYD is a commercial white, with a fancy flower

The only ever-blooming, large-flowering white in existence

Will take the place of all other whites now in commerce. Every New Bedford grower has bought stock. Come and investigate.

**A KEEPER
A SHIPPER
A BLOOMER**

It will bring the shekels when all others fail

\$2 pr 12. \$12 pr 100. \$100 pr 1000

H. A. JAHN

NEW BEDFORD, - - MASS.

CATALOGUE OF

New Chrysanthemums Roses, Etc.

Now ready, I am headquarters for the new singles, and carry the cream of the world's novelties. If you are interested send for my list. It's yours for the asking.

CHARLES H. TOTTY
Madison, - - - N. J.

HYDRANGEA OTAKSA FIELD CROWN

6c, 8c, 10c and 15c each by the dozen or hundred. Fine stock.

BAUR FLORAL CO., Erie, Pa.

Select Stock of Strong Well Rooted Carnation Cuttings.

	Ready Now.	Per 100	Per 1000
Andrew Carnegie (Scarlet Harlowarden).....	\$12.00	\$100.00	
Aristocrat , bright cerise.....	6.00	50.00	
Windsor , pink.....	6.00	50.00	
Beacon , orange scarlet.....	6.00	50.00	
White Enchantress , pure white.....	6.00	50.00	
Welcome , pink.....	6.00	50.00	
Red Chief , Christmas scarlet.....	6.00	50.00	
Rose Pink Enchantress	3.00	25.00	
White Perfection	3.00	25.00	
Enchantress	3.00	25.00	
Daybreak Lawson	3.00	25.00	
Victory , scarlet.....	3.00	25.00	

CHICAGO CARNATION COMPANY,
A. T. PYFER, Mgr. JOLIET, ILL.

CARNATIONS ROOTED CUTTINGS

Winona, color, true clear pink, comes nearest to Fiancee but a different type flower. Growth on order of Scott but vastly improved in every respect. Early flowers in quantity and on long stems. Does not burst its calyx. Fine, shapely, active growth. In color and productiveness it is without an equal. Orders booked now and filled in strict rotation. \$12 per 100, \$100 per 1000.

White Perfection, pure white. We have a large stock. \$3 per 100, \$25 per 1000.

F. DORNER & SONS CO.
LA FAYETTE, IND.

Carnation Cuttings

Both standard varieties and novelties. Stock guaranteed to be first-class. Address,

S. S. SKIDELSKY

1741 North 18th Street, Philadelphia

ANNOUNCEMENT

Our new seedling carnation, **TREADOR**, will not be disseminated until January 1909.

For further particulars address,
The H. WEBER & SONS CO., Oakland, Md.

Wanted - Unrooted Cuttings

of Rose Pink and White Enchantress, Victory and Beacon.

ADDRESS, C. L., care of WELCH BROTHERS
226 Devonshire Street, Boston

Rooted Carnation Cuttings

Pink	100	1000
Aristocrat	\$6.00	\$50.00
Windsor	6.00	50.00
Rose Pink Enchantress	3.50	30.00
Enchantress	3.00	25.00
Lawson	2.50	20.00
Joost	2.00	15.00

White	100	1000
White Perfection	3.00	25.00
" Enchantress	6.00	50.00
" Lawson	3.00	25.00
Queen	2.00	18.00
Boston Market	2.00	18.00
Louise	2.00	18.00
Lt. Peary	3.00	25.00
Bountiful	2.50	20.00

Red	100	1000
Beacon	6.00	50.00
Victory	3.00	25.00
Robert Craig	3.00	25.00
Flamingo	2.50	20.00

Miscellaneous	100	1000
Patten	2.50	20.00
Harry Fenn	2.50	20.00
Harlowarden	2.50	20.00

Stock Guaranteed - Prompt Deliveries

THE LEO NIESSON CO.
WHOLESALE FLORISTS
1209 Arch St., PHILADELPHIA

JOHN E. HAINES Bethlehem, Pa.

is the place to order rooted-cuttings of the following varieties for 1908.

John E. Haines, red	} Per 100 Per 1000	\$6.00 \$50.00
Imperial variegated		
Pink Imperial, Pink		
Enchantress, Light Pink		

Place your orders early for Jan. delivery.

PURE **ENCHANTRESS** WHITE

ROOTED CUTTINGS
\$6.00 per 100 \$50.00 per 1000

JACOB SCHULZ
644 4th Ave., LOUISVILLE, KY.

Prices Quoted in these Columns are for Dealers Only. When Writing to Advertisers Please Mention HORTICULTURE.

Sweet Peas at Christmas

The accompanying photograph is of a sweet pea house here taken just before Christmas. The varieties are Mont Blanc, and Christmas Pink (Zvolanek's). They were sowed the first week in September, and were grown along very cool until they commenced to set bud. The temperature was then increased to 52 degrees nights and 65 to 68 degrees on bright days. They are on the solid and are planted in rows three feet apart crosswise the house. The house is 30 feet wide. The rows are 26 feet long allowing 2 feet at each side for passage way. The house is 6 feet high at the eaves. Cutting was commenced at Thanksgiving. All the heating pipes are on the sides.

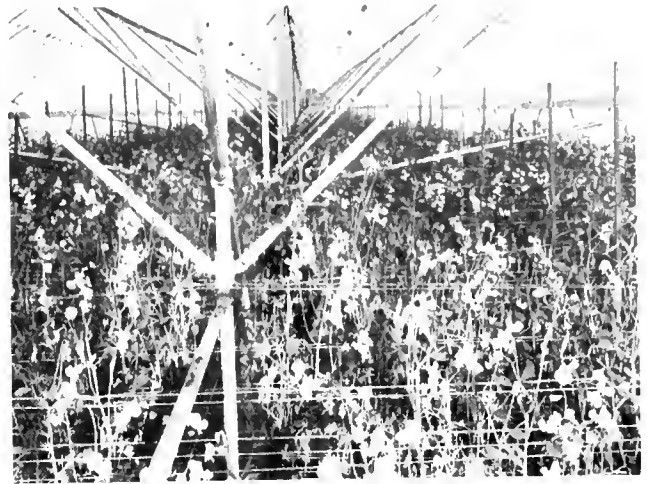

William Lin

The Paeony Disease

Editor HORTICULTURE:

The article in your paper of January 14th, by Mr. E. W. Morse in reference to a new paeony disease, is very likely nothing but what paeony growers have known for some years as the Black Rot. From observations which I have made, I am inclined to the belief that the infection takes place in the ground.

In dividing a fine variety in fall of 1906 into thirteen divisions I found that in May, 1907, three of the divisions had failed to grow. In digging them up, it was observed that the crown was rotted off of all three. These could not have been affected through the leaf and stalk, because the stalk had been cut off to three or four inches when the whole plant was divided.

The treatment given these three roots was taking them and cutting away the affected parts, and planting them in a new place after a thorough dusting with air-slacked lime. All three grew. One was finally cut off by cut worms; but the other two grew all through the season, and I believe they will come all right next spring. As many as eight years ago I read an article by a German professor saying that the best remedy for this disease was lime.

I have tried also this treatment. Dig the plant up and cut away the bad part and soak the plant in a solution of Formalin, then plant in an entirely new place. An old grower whom I have corresponded with in France soaks them in a solution of sulphate of iron. The Formalin solution is the best fungus killer.

I have lost wholly only two plants by this disease, so far as I know, and these I neglected.

E. J. Shaylor

Peony Specialist.

Weights and Areas for Fertilizers

The table below may be useful to those who wish to compare the amounts of fertilizer used outdoors on large areas with corresponding values used indoors on small areas. It may also interest those wishing to use a soluble fertilizer by means of tanks, Kinney pump, wheeled water-barrel or hand water can.

Pounds per acre. (43,560 sq. ft.)	1 lb. will cover	1 oz. will cover
2,000 Pounds	22 sq. ft.	1.3 sq. ft.
1,000 "	44 "	2.7 "
900 "	48 "	3 "
800 "	55 "	3.5 "
700 "	62 "	4 "
600 "	72 "	4.5 "
500 "	87 "	5 "
450 "	97 "	6.5 "
400 "	109 "	7 "
350 "	124 "	8 "
300 "	145 "	9 "
250 "	174 "	11 "
200 "	218 "	14 "
150 "	289 "	18 "
125 "	336 "	22 "
100 "	436 "	27 "
75 "	578 "	36 "
50 "	872 "	54 "
40 "	1,090 "	68 "
30 "	1,446 "	90 "
25 "	1,744 "	108 "
20 "	2,178 "	136 "

In case of plant foods dissolving completely in water values much stronger than 200 lbs. to the acre would not commonly be used and in most cases much less.

It should always be clearly borne in mind that the standard referred to in applying any fertilizer is the *weight per area* and in the case of water soluble nutriment the actual weight that finally reaches the soil depends on both the *amount in the water* and the *amount of water applied* to the area in question.

Rudley M. Pray

HORTICULTURE

VOL. VII

JANUARY 11, 1908

NO. 2

PUBLISHED WEEKLY BY
HORTICULTURE PUBLISHING CO.
 11 Hamilton Place, Boston, Mass.

Telephone, Oxford 292

WM. J. STEWART, Editor and Manager

SUBSCRIPTION PRICE

One Year, in advance, \$1.00; To Foreign Countries, 2.00; To Canada, \$1.50

ADVERTISING RATES

Per Inch, 30 inches to page \$1.00.

Discounts on Contracts for consecutive insertions, as follows:

One month (4 times) 5 per cent.; three months (13 times) 10 per cent.;

six months (26 times) 20 per cent.; one year (52 times) 30 per cent.

Page and half page spaces, special rates on application.

COPYRIGHT, 1908, BY HORTICULTURE PUB. CO.

Entered as second-class matter December 8, 1904, at the Post Office at Boston, Mass. under the Act of Congress of March 3, 1879.

CONTENTS

	Page
FRONTISPICE—New Violet "Boston."	
SWEET PEAS AT CHRISTMAS—Wm. Sim, Illustrated	33
THE PAEONY DISEASE—E. J. Shaylor	33
WEIGHTS AND AREAS FOR FERTILIZERS— Dudley M. Pray	33
BRITISH HORTICULTURE—W. H. Adsett	35
ROYAL GARDENS, KEW—Thos. Bunyard	35
AFTER ADJOURNMENT	36
HOUSE OF VIOLET "BOSTON"—Illustrated	36
AMERICAN CARNATION SOCIETY	37
NEWS OF THE CLUBS AND SOCIETIES:	
Western New York Horticultural Society—Worcester County Horticultural Society—North Shore Horticultural Society—New Jersey Horticultural Society—Southampton Horticultural Society	38
Massachusetts Horticultural Society—Society of American Florists	39
Florist Club of Philadelphia—Florists' Club of Washington—Club and Society Notes	42
SEED TRADE	40
CATALOGUES RECEIVED	40
FLOWER MARKET REPORTS:	
Boston, Buffalo, Detroit, Indianapolis, New York, Philadelphia, Toledo, Washington	45
MAINTAINING SOIL FERTILITY	53
OBITUARY	53
Everett B. Clark, Portrait	53
MISCELLANEOUS:	
Personal	36
News Notes	42-43
New Retail Flower Stores	43
Business Changes	45
A Profitable Aster—Illustrated	52
Good Results of Inspection Laws	52
Posts Made Durable	54
Greenhouses Building or Contemplated	54

The carnationists' opportunity
 We are reminded of the rapid flight of time by the near approach of the Carnation Society meeting at Washington. Only three weeks away; and yet it seems but a few weeks since we said adieu to the hospitable Torontonians. No doubt the gathering at Washington will equal, if not exceed, any conclave of carnationists ever held. Anyone interested in the divine flower (and what florist is not) who volun-

tarily misses the opportunity presented in this Washington convention deserves to get left in the upward and onward movement which is carrying his more enterprising fellows to favor, fame and fortune, as he surely will if he continues unmindful of the advantages which others are eager to grasp. "Watch your opportunity."

Get "a move on" over and its real or fancied effect upon the floral and other horticultural interests is

Now that the financial flurry is apparently fully comprehended it remains for all concerned to get down to active business once more and, with old-time confidence and courage, lay foundations for the immediate future. We are not only at the beginning of a new year but, as many believe, on the threshold of a new and more healthy business development and now is the opportunity of a life-time—that "tide in the affairs of men which taken at the flood, leads on to fortune." Years hence men will look back to this juncture not so much as an emergency as an opportunity and they will designate by name the men who rose to the opportunity and improved it. It is no time now to mourn over the past or eringe at the imaginary future. Let every one get right into harness and do business at the old stand with double the old enthusiasm.

Helping one another

A promising sign of the times is the evident willingness of hitherto widely separated branches of horticultural industry to get together and work in unanimity in those directions where their interests are identical. We have had occasion to note this tendency in several recent instances—notably the Minnesota Horticultural Society, whose president in his annual address said that "the policy of our society is that of doing anything in a horticultural way that may be helpful to mankind," and the Maryland Horticultural Society under the guidance of such sterling men as Orlando Harrison, and Prof. Symonds—both societies representing strong fruit-growing communities but welcoming to full participation in the meetings and exhibitions the representatives of floriculture with a fraternal cordiality equalled only by the willingness and enthusiasm with which the latter entered upon their joint duties. The conditions which worked to segregate these interests in the past need not now be recounted; it is sufficient to know that we have outlived and largely overcome them and he who would seek to perpetuate them is no friend of horticulture. It is well that the distinctly divergent needs of the many sections of horticulture should be cared for by independent organizations. The more we have of these engaged in special work the better will fundamental details be attended to and the wider and deeper will the feeding roots of the great tree extend but there are many points of contact where union of effort will bring increased vigor and robust strength to horticulture in its broadest sense and we are glad to see things heading that way.

British Horticulture

RETROSPECTIVE

The year just closed was not altogether favorable to gardening operations, the weather at the early part of the summer being particularly trying. Despite these drawbacks, there are many satisfactory incidents to record, which indicate that the various departments of horticulture are making a steady progress. The Royal Horticultural Society continues to meet with encouraging success. The Society's various shows met with enthusiastic support both from the exhibitors and the public. A notable achievement has been the opening of new laboratories at the Society's extensive gardens at Wisley. This extension is likely to materially add to the Society's usefulness. The National Rose Society as is befitting an organization associated with the National flower, is making good headway. During the past year 577 new members have joined, whilst the membership has been doubled in a period of five years. The Society serves a useful purpose not only in organizing popular shows, but in the dissemination of valuable information amongst rosarians. The National Sweet Pea Society is also in the sunshine of prosperity. A new society has lately come into existence to cater for the sweet pea enthusiast in the Midland countries. The Winter Flowering Carnation Society judging from the success attending the last show, has come to stay. The British Gardeners' Association, formed to raise the status of the working gardener, is adding to its membership roll. The first number of its quarterly "Journal" has been brought out. Another useful move has been the federation of the horticultural Mutual Improvement Societies, under the auspices of the Royal Horticultural Society.

A BRITISHER ABROAD

Mr. W. Harrison, a member of the firm of Messrs. Harrison, Cragg and Harrison, market nurserymen, of Heston, Middlesex, has returned from a tour in the United States. He has lately recounted his experiences and incidents of his travels. Amongst his conclusions he states: "I think it is fair to say I have come back with a profound respect for the American's push and ability to get through, as well as his readiness to avail himself of the many labor-saving devices his intelligence and better education enable him to utilize." Mr. Harrison was considerably impressed by the fruit growing in Colorado, and the excellent system of co-operation adopted amongst the growers. He winds up by stating "I cannot conclude without acknowledging the heartiness and cordiality of my welcome from both eastern and western growers alike. I went out there expecting to be a stranger in a strange land; I left the country amazed and touched by the friendliness I experienced from every one. Instead of being a stranger I was treated as an honored guest, and I look forward with great eagerness to the time when I shall once again renew the many warm friendships I made during my visit to the other side." It is well that there should be these interchanges of visits. These not only widen one's experience, but remove the prejudices sometimes formed by an uninformed isolation. I am quite sure that should any American grower pay a return visit they would find a cordial welcome awaiting them on this side.

W. H. Adsett.

Royal Gardens, Kew

Being no halls to attend I turn my attention to the above, which if it be not should be the pride of every Britisher, for it is acknowledged to be the best and most complete establishment of its kind in Europe. It is not the time of year to see the various arboretums, or even to visit the beautiful rock garden, so will make my way at once to the show house, familiarly known as No. 4 to see what is there displayed. Its popularity is mainly through its being the gathering place of all subjects when they are flowering—or at least at their best from a decorative point of view, and therefore, there is no botanical exclusiveness in the denizens of the house, which in the summer often has alpine plants from the snow line of the Alps cheek by jowl with East Indian orchids and hardy but forced shrubs forming a background to forced bulbs in pots. It is here that the market florist often gets a useful hint of the practical value of a little known plant, and as the aim of Kew is to be as near as possible up to date here may be seen the novelties from Europe, and the cream of those from America, not to mention fresh introductions from our colonies either in the tropics, the southern archipelago, or simply from Australia, New Zealand, or Polynesia generally. Entering by the Cumberland gate, one could but note how green and fresh were the ferns under the shade of the trees. *Polystichum* I should call them but as usual that is not the Kew name—so in future I must call them *Aspidium*. Wisely, the *Hypericum calycinum* is freely used under trees as it soon carpets the ground and drip does not injure it. To add a little brightness some fine clumps of *Helleborus niger* were just opening their flowers—justifying its title of Xmas rose. A near way to No. 4 was through the houses devoted to cool orchids. The first thing that strikes one on entering No. 4 is a batch of plants of *Peristrophe speciosa* from the Himalaya. *Crassula lactea* was freely used along the edges of the stage. In the centre bed were specimens of late chrysanthemums. A pretty light-flowering sweet-scented thing is *Eupatorium Weinmannianum*. *Senecio Potasitis* is displaying some massive heads of its bright star-like flowers. Commanding notice here was an elegant fountain-like plant of *Buddleia Asiatica*, diffusing its delicious odor around: even if it fails to prove hardy, it will at any rate be a great gain in plants suitable for winter-garden decoration. The side benches had some very good *Primula sinensis*, Sutton's giant strain. Reading Blue is a true blue, and Giant White is a superb fringed flower of great substance. *Acacia platyptera* was the only one in good flower, *longifolia* coming along, while one pinnate leaved kind, with a very light and elegant habit of growth was labelled *Baileyana*, but was not yet flowering. *Luculia gratissima* was past, but a pretty batch of *Plumbago rosea* demonstrated that this variety is well adapted for pot culture and most useful at this season.

Plants of *Moschosma riparium* were dotted along the margin of the centre bed and were bearing many of their pretty flower spikes. *Begonia Lorraine*, *narcissi*, *cyclamens*, *nicotiana*, *Primula Kewensis* and such like well-known plants, made a very pretty display. A very fine winter flowering scarlet zonal *Polygonium* is Paul Crampel.

Thomas Buryard.

AFTER ADJOURNMENT.

January 28th, 29th and 30th. These are the dates for the carnation meeting at Washington. Patten up your pet seedlings, put them in the ring at Washington and you'll soon find out their "trotting" value.

Better flowers, better workmen, better system, are things much to be desired but let every florist also exert himself to devise better ways of using what we already have. There's plenty of room for improvement.

The road to success in floriculture is paved with industry, tenacity and that kind of enterprise which gets its stimulation from visiting the most successful establishments and the exhibitions and reading the best horticultural literature.

The growers whose roses or carnations are top-notch quality plumes himself upon his methods and good management but the one with low-grade product charges it to the weather, the late foreman or the man who sold him the stock.

It is to be hoped that the generally satisfactory conditions reported from most sections at holiday time may continue without impairment throughout the winter floral season. It would seem from the way the florist business has been sustained during the recent financial strain that plants and flowers and fancy greenhouse products of all kinds have graduated for good from the "luxury" class.

"Solomon was fain to admit that there were three things too wonderful for him; yea, four which he knew not: 'The way of an eagle in the air; the way of a serpent upon a rock; the way of a ship in the midst of the sea; and the way of a man with a maid.' Had Solomon lived till this day and generation he would have added a fifth puzzler, to wit: The way of an express company with a prepaid package."—*Phila. Record.*

And perchance a sixth: The way of a flower wholesaler with a fakir.

An announcement of the spring exhibition of the American Rose Society occupies the back cover page of the program and schedule of the American Carnation Society. That is the right sort of spirit. Let us have more of it.

"For a' that, an' a' that,
It's comin' yet for a' that,
That man to man the world o'er
Shall brethren be for a' that."

Fix up your show window. There are very few of these that cannot be improved and it is impossible to have them too well done. This does not mean extravagant and wasteful use of high-priced flowers but it does mean scrupulous cleanliness, simplicity and pure taste in arrangement, and resourceful proficiency in making effective use of the things most available at the time. Always combine beauty and utility.

Commenting on the New York Herald's estimate of \$1,750,000 as the amount spent by New Yorkers to give

HOUSE OF VIOLET "BOSTON."



appropriate welcome to the New Year, the *Philadelphia Record* says:

"No doubt this joyousness was in part due to the rebound from the depression of the last days of the old year. It is, however, a good symptom. To eat and drink so much may be a little provocative of indigestion, but it puts hoarded money in circulation and starts the wheels moving."

Very true, and, as we have said before, blessings on the good spenders. When America gets to wearing old shoes it will be a cold day for the florist and gardener.

In the light of the heavy supply of orchids for which the New York market could find no outlet at the Holidays that article published in the *New York Times* about the famine in orchids with famine prices ought to incite the fool-killer to load his gun and prepare to do business. "On Thursday night" it tells us "one of the dinner givers ordered orchids for table decorations. He took his chances and gave a carte blanche order. He found that the dinner and champagne were far less in price than the two dozen orchids, which nodded gracefully from their nests of maiden-hair fern. Then he appreciated the ravages of the orchid famine." This is the sort of ruinous rot which scares away business, leaves the wholesalers' ice-boxes full and gives the grower a cold chill.

The report of the Connecticut Agricultural Experiment Station on Fertilizers, for 1907, is interesting reading and should set the man who uses fertilizers to serious thinking. Many pages of analyses and valuations of special manures are given. We clip the following statement as being especially worth consideration by those growers who are in the habit of using the two mixtures analysed.

"Two samples of fertilizers made in England especially for florists' use were sent for analysis by Thos. W. Head, Groton, Conn.

No. 19275. Clay's Fertilizer for chrysanthemums and general flowering stock, imported in bags and tins, for sale at \$7.00 per hundred weight.

No. 19276. Thompson's Vine Ma-

nure imported in bags and sold for \$6.75 per hundred pounds.

	Thompson's Vine Fertilizer, No. 19275	Clay's Fertilizer, No. 19276
Nitrogen as ammonia	1.81	1.77
Nitrogen, organic	3.09	2.42
Nitrogen, total	4.90	4.19
Water-soluble phosphoric acid	0.08	5.46
Citrate-soluble phosphoric acid	1.50	1.54
Citrate-insoluble phosphoric acid	7.11	2.31
Total phosphoric acid	8.69	12.31
Water-soluble potash	0.18	7.31
Valuation per ton	\$23.43	\$32.80

No. 19276 apparently contained horn shavings. Nitrogenous superphosphates or specials can be bought here for from \$30 to \$35 which contain as much available plant food as these fertilizers which sell at preposterous prices."

PERSONAL.

Visiting Detroit: Mr. Holm of St. Paul, Minn.

George Ostertag has been re-appointed superintendent of parks at St. Louis for four years.

A. R. Cutting, editor of the *Canadian Florist*, Toronto, was married on January 1 to Miss Rita J. Revett of Chicago.

Visiting Boston: F. R. Pierson and J. R. Fotheringham of Tarrytown, N. Y., the latter just back from Europe.

Visitors in Newport, R. I.: Rickards Bros., New York, and John Beaton, representing R. & J. Farquhar & Co., Boston.

M. B. Bunker, florist, of Boston, was obliged to go to the Boothby Hospital on Wednesday, January 8, to undergo a painful operation.

Harry C. Hogan has been appointed gardener to Mr. Reginald Vanderbilt in Newport. Mr. Hogan was previously employed on the estate as foreman.

Mr. John Mahan, superintendent on the Auchincloss estate, was elected one of the license commissioners for the city of Newport, R. I., at the election last Monday.

AMERICAN CARNATION SOCIETY

The Seventeenth Annual Meeting and Exhibition of this Society will be held in the National Rifles Hall, 918 G street, N. W., Washington, D. C., January 28, 29 and 30, 1908. Exhibition on the first floor, sessions on the second floor. Address all exhibits to Chas. McCauley, Washington, D. C. Express charges on all exhibits must be prepaid.

Papers will be read as follows: "Experiments in Carnation Growing by the Department of Agriculture," by Dr. B. T. Galloway, Washington, D. C.; "Carnation Breeding," by Prof. J. B. Norton, Washington, D. C.; "What the buyer of a New Carnation should expect from The Originator," by S. S. Skidelsky, Philadelphia, Pa.; "What The Originator of a New Carnation should expect of the buyer," by W. N. Rudd, Mt. Greenwood, Ill.; "Special Points on Carnation Hybridizing," by Peter Fisher, Ellis, Mass.; C. W. Ward, Queens, N. Y.; Fred. Dorner, LaFayette, Ind., and Richard Witterstaetter, Cincinnati, O.; "Cultural Methods for Carnations," by Irving Gingrich, South Bend, Ind.

Exhibitions Rules and Regulations.

1. All entries must be forwarded so as to reach the secretary, Albert M. Herr, Lancaster, Pa., not later than Wednesday, January 15. Exhibitors from a distance will please note the date and mail accordingly, as a charge of \$1 for each variety entered will be made for those not entered as above requested.

2. All entries not staged by 1 P. M., January 28, will be disqualified from any and all competition excepting for "Certificate of Merit."

3. None but members of the Society are eligible to compete for any prizes, medals or certificates.

4. All exhibits for competition must have the variety correctly labeled, if a named sort, or numbered if an unnamed seedling. The Society will furnish a uniform card for this purpose, and varieties not labeled or numbered with this card will not be judged in any of the classes. The secretary will typewrite these cards for exhibitors who get their entries in early enough for him to do it, and furnish them to the exhibitor in Washington any time during the morning of January 28.

5. The same vase is not allowed to compete for more than one prize, excepting those entered for Certificates and where otherwise stated.

Scale of Points.

This scale shall be employed in judging all seedlings for Certificate of Merit, or for any special prize, and in all classes where competition is close, it shall be used to arrive at a decision: Color, 25; size, 20; calyx, 5; stem, 20; substance, 10; form, 15; fragrance, 5; total, 100.

Rules Governing the Award of Certificates of Merit.

A variety must have been bloomed not less than three years; not less than fifty blooms must be shown, and an entrance fee of \$5.00 is charged for each variety. The variety must be properly

labeled with the Society's Card. (See Rules and Regulations.)

Preliminary Certificate.

This can be competed for by two-year-old seedlings, twelve blooms or more to be shown, and an entrance fee of \$2.00 paid for each variety. The variety must be properly labeled with the Society's Card. (See Rules and Regulations.)

General Premiums.

Class A.—Open to all varieties, Seedlings or Standard Sorts:—

No.	100 Blooms	First Prize.	Second Prize.
1.	White	\$10.00	\$5.00
2.	Enchantress shade of Pink	10.00	6.00
3.	Lawson shade of Pink	10.00	6.00
4.	Winsor shade of Pink	10.00	6.00
5.	Scarlet	10.00	6.00
6.	Crimson	10.00	6.00
7.	Yellow Variegated	10.00	6.00
8.	White Variegated	10.00	6.00
9.	Any other color	10.00	6.00

Class B.—Open to all varieties disseminated prior to July 1st, 1907:—

Classes No. 10 to No. 36, each for a first prize of \$5.00, and second prize of \$3.00 for fifty blooms of the following varieties respectively: Lady Bountiful, White Perfection, any other White, Enchantress, any other Enchantress shade of Pink, Winsor, Pink Enchantress, any other Pink (this shade), Lawson, Aristocrat, Pink Imperial, any other Dark Pink, Robert Craig, Red Chief, Victory, Beacon, any other Scarlet, M. A. Patten, Imperial, any other White Variegated, Harry Penn, Harlowarden, Any other Crimson, Eldorado, Any other Yellow Variegated, Prosperity, Any other Color. Three prizes may be awarded under No. 36.

The American Carnation Society Medal.

Class C.: A gold medal will be given for the best vase of 100 blooms, any variety, any color.

A silver medal will be given for the second best vase of 100 blooms, any variety, any color.

A bronze medal will be given for the third best vase of 100 blooms, any variety, any color.

Special Medals of the Society of American Florists.

Class D.: A silver medal will be awarded for the best vase of 50 blooms of carnations not yet disseminated.

A bronze medal will be given for the second best vase of 50 blooms of carnations not yet disseminated.

The variety to be in all cases of American origin.

Judges are to reserve awards in this class if in their opinion the exhibits are not worthy of the medals.

Special Prizes.

The Henry F. Michell Co., Philadelphia, Pa., offer a silver vase valued at \$40.00 for the best 100 blooms of carnations in four varieties, twenty-five blooms to a variety. Open to private gardeners only.

Peter Bisset, Washington, D. C., offers \$10.00 in gold for the best display of carnations grown by a private gardener distinct from Michell's prize.

Peter Fisher, Ellis, Mass., offers

prizes for the best fifty blooms of Beacon: 1st, \$12.00; 2nd, \$8.00; 3rd, \$5.00.

Geo. H. Cooke, Washington, D. C., offers \$10 in gold for the best 25 blooms pink seedling or sport darker than Enchantress and lighter than Lawson, never before winning a prize or medal. Those having a preliminary certificate eligible. Entries for this prize will not be eligible to compete for any other prize.

Geo. C. Shaffer, Washington, D. C., offers \$10 in gold for the best vase of 50 blooms, not more than three varieties, open only to growers having less than 20,000 feet of glass.

S. C. Briggs, Washington, D. C., offers \$10 in gold for the best vase of white carnations, 50 blooms, distinct from other entries.

John Robertson, Washington, D. C., offers \$5 cash for best 25 blooms of Winsor, distinct from other entries.

Mr. J. J. Harty, Washington, D. C., offers a silver cup to the exhibitor making the largest display—all vases in all classes being counted as part of this display.

Z. D. Blackistone, Washington, D. C., offers \$10 in gold for the best 50 blooms of white carnations, distinct from other entries.

C. A. Goldsmith, jeweler, Washington, D. C., offers a cup or stein for the best 50 blooms of red—new or standard variety. Vases for this prize not to be entered in any other class. Red meaning Beacon, Victory or Craig shade of red.

Headquarters.

Hotel Raleigh will be headquarters. It is a first class hotel and can accommodate all members who wish to stop there. The rate is from \$2 per day upward.

Officers for 1907-'08.

President, Fred Lemon, Richmond, Ind.; vice-president, Peter Bisset, Washington, D. C.; secretary, Albert M. Herr, Lancaster, Pa.; treasurer, Fred. Dorner, Jr., Lafayette, Ind.; directors, Fred Lemon, Peter Bisset, Albert M. Herr, Fred. Dorner, Jr., Wm. Weber, Wm. Gammage, J. S. Wilson, J. F. Wilcox, Eugene Dailedouze.

Officers of the Florists' Club of Washington.

President, Peter Bisset, vice-president, Z. D. Blackistone; secretary, Chas. McCauley; treasurer, Wm. H. Ernest; directors, Peter Bisset, Z. D. Blackistone, Chas. McCauley, Wm. H. Ernest, Geo. C. Shaffer, W. S. Clark, W. F. Gude, John Robertson.

Carnation Registered.

H. W. Field, Northampton, Mass., registers President Seelye, a pure white seedling from Mrs. Thos. W. Lawson and "Queen."

ALBERT M. HERR,
Lancaster, Pa.

On Wednesday evening, January 15th, the Tarrytown Horticultural Society will enjoy its annual dinner at the Florence Hotel. There will be "hospitality sitting with gladness" and then will come "Discourse, the sweeter banquet of the mind." The latching string will be out as usual.

NEWS OF THE CLUBS AND SOCIETIES.

WESTERN NEW YORK HORTICULTURAL SOCIETY.

The 53rd annual meeting of the Western New York Horticultural Society will be held in the Eureka Club building, Rochester, January 22nd and 23rd. The programme follows:

Wednesday, Jan. 22 10:30 a. m., appointment of committees, report of secretary-treasurer, trustees of permanent fund, state fair exhibit F. E. Rupert, chairman, committee on preservation of the pomological history of N. Y. state; Prof. John Craig, chairman, committee on botany and plant diseases; Prof. F. C. Stewart, N. Y. Agricultural Experiment Station.

Afternoon session, 2 o'clock: "Twenty-five Years of Experiment Station Work," Dr. W. H. Jordan, N. Y. Agricultural Experiment Station; "Are We Planting Enough Varieties?" Wm. A. Taylor, U. S. Dept. of Agriculture; "Tillage vs. the Sod-Mulch," Prof. U. P. Hedrick, N. Y. Agricultural Experiment Station; "Co-operation in the Packing and Marketing of Orchard Fruits," M. C. Burritt, College of Agriculture, Cornell University; "Atmospheric Nitrogen as a Future Commercial Source of Plant Food," Dr. L. L. Van Slyke, N. Y. Experiment Station; "Progress of Inspection Work with Apples," Prof. John Craig, Ithaca, N. Y.; Report of Legislative Committee, S. D. Willard, chairman; a few words relative to fruit packing, by Prof. Lowell Judson, College of Agriculture, Cornell University.

Evening session, 7:30 o'clock.—"Some Observation on Fruit Insects," Prof. P. J. Parrott, N. Y. Experiment Station; "Relation of Birds to Horticulture," Prof. Howard E. Eaton, Canandaigua, N. Y.; Discussion.

Thursday, Jan. 23rd, 9:30 A. M.—Members' hour, conducted by Geo. T. Powell, Ghent, N. Y.; "Planting and Caring for a Peach Orchard," S. H. Fulton, Sleepy Creek, W. Va.; Report of committee on nominations; Election of officers; "Dwarf Apple Trees in Commercial Orchards, and the Value and Possibilities in Dwarfing Standard Trees Through Special Means of Pruning," George T. Powell, Ghent, N. Y.; "Small Fruit Culture," W. W. Farnsworth, Waterville, Ohio.

Afternoon session, 2 o'clock.—Members' hour for discussion of special questions; Report of committee on fruit exhibit at this meeting; Unfinished and new business; Report of committee on resolutions; Discussion of questions for balance of session.

Practical addresses by practical men for practical fruit growers, is the keynote running all through the programme. One other great attraction connected with this gathering is the exhibition of choice fruit. Not less than a thousand square feet of space will be required for the display. The State Experiment Station will use one-half to three-fourths of the space. Many of the addresses will be illustrated with stereopticon views. This makes a combination of entertainment and instruction.

WORCESTER COUNTY HORTICULTURAL SOCIETY.

The winter program of meetings at Horticultural Hall, Worcester, Mass., is as follows:

Thursday, Jan. 2—"Maintaining Soil Fertility," by Prof. L. A. Clinton, director of Storrs Agricultural Experiment Station of Connecticut; Thursday, Jan. 9—"Italian Gardens," illustrated by stereopticon, John Farquhar of Boston; Thursday, Jan. 16—"Improvement of Vegetables by Selection and Hybridization," M. F. Hall, horticulturist at the New Hampshire college; Thursday, Jan. 23—"Embellishment of Streets and Waysides by the Planting of Trees," J. A. Pettigrew, department of parks, Boston; Thursday, Jan. 30—"Children's Home Gardens," O. A. Morton, superintendent of schools, Marlboro.

Thursday, Feb. 6—"Rural Life," Joseph K. Greene of Worcester; Thursday, Feb. 13—"Ladies' day. Music, and Mrs. George S. Ladd will speak on the "Influence of Horticulture." Mrs. David L. Fiske on "Practical Horticulture," and Mrs. Sarah E. Brown on "Aesthetic Horticulture"; Thursday, Feb. 20—"A Campaign for Rural Progress," Kenyon L. Butterfield, president of the Massachusetts Agricultural College; Thursday, Feb. 27—"Forestry," Philip W. Ayres of Concord, N. H., forester for the Society for the Protection of New Hampshire Forests.

Thursday, March 5—Subject and speakers to be announced; Wednesday, March 11—Annual reunion of the society; March 11 and 12—Massachusetts Fruit Growers' convention; Thursday, March 12—"How Can We Develop Commercial Orcharding in Massachusetts," F. C. Sears, pomologist at Massachusetts Agricultural college.

The program was arranged by President George Calvin Rice, Secretary Adin A. Hixon, Arthur J. Marble, Edward W. Breed, J. Lewis Ellsworth and Charles W. Wood, committee on winter meetings.

NORTH SHORE HORTICULTURAL SOCIETY.

This society held its regular meeting January 3rd. In the absence of Pres. McGregor, the chair was occupied by Vice-President Thomas Jack. Reports from officers for 1907 were read and accepted, the treasurer and financial secretary's report showing the society to be in a flourishing condition with an increase in finance and membership. The annual election of officers followed, resulting as follows for 1908: President, William Till; vice-president, A. E. Parsons; treasurer, John Baker; financial secretary, Herbert Shaw; recording secretary, James Salter; executive committee, Philemon Sanborn, J. B. Dow, Joseph Clark, Sr., W. H. Tyler, James McGregor.

In accepting the chair, the president thanked the members for their confidence and stated that he would not make or advocate any radical change in the policy of the society.

The annual banquet will be held in Manchester Town Hall, January 29, at 1:30 P. M. W. T.

NEW JERSEY FLORICULTURAL SOCIETY.

The installation of the following officers took place on the 3d instant with the usual ceremony. President Malcolm MacKorie; vice-president, Henry Halbig; secretary, Orson A. Miller; treasurer, William Read. After discussion it was decided to hold special public exhibitions of carnations, roses, dahlias and chrysanthemums and offer special inducements for flowers in season at the regular monthly meetings.

In the competition for 1907 the following winners of prizes were announced: 1st, Peter Duff, gardener for John Crosby Brown; 2nd, William Read, gardener for the Colgate Estate; 3d, Max Schneider, gardener for Chas. Hathaway; and in the special class for growers without glass, Arthur T. Caparn, gardener for Stewart Hartshorne. Among the non-competitive awards certificates were given to F. R. Pierson Co., Lager & Hurrell, Julius Roehrs Company, W. A. Manda, Robert Scott, Thomas Jones, Joseph A. Manda, J. C. Williams and Henry Hornacker. Cash prizes aggregating forty dollars were donated by the following: Peter Henderson Company, J. M. Thorburn & Co., Vaughan's Seed store and F. R. Pierson Co.

In the floral display for the evening, orchids preponderated. *Cypripedium Leeanum Clinkaburyanum*, the finest form of this genus in existence and *Cypripedium insigne Luciana*, the yellow form, by Lager & Hurrell; four vases of cut blooms of *Cattleya Trianae alba* of several distinct forms, by Thomas Jones; *Epidendrum lonopsis* and *Cypripedium Leeanum Clinkaburyanum* by Orson A. Miller of East Orange, the new secretary, who has come out as a grower for the trade and is now in active competition with "Willowmead" of the same place. All of these growers promise to revive during the present year, the old latent partiality for the *cypripedium* claiming that it is still alive though dormant. Joseph A. Manda of West Orange, contributed a vase of *Anthurium Andreanum giganteum*; roses from the estate of Douglas Robinson, John Garvan, gardener, and violets from Charles Hathaway, Max Schneider, gardener. An invitation from the Morris County Gardeners to their smoker on the 8th was read and a committee appointed to go there. Satisfactory reports were received from secretary and treasurer.

JOSEPH B. DAVIS.

SOUTHAMPTON (L. I.) HORTICULTURAL SOCIETY.

The first annual meeting of this society was held on Thursday, January 2, President Clark in the chair. Officers elected for the ensuing year were as follows: President, H. W. Clark; vice-president, Wm. T. Halsey; recording secretary, E. C. Palmer; financial secretary, Charles Gillouz, in place of Wm. Gray, resigned; treasurer, Julius King. The appointment of the execu-

five committee was held over till the next meeting. There were the usual interesting discussions, the principal one being the construction, care and management of lawns, which subject was very ably discussed by Messrs. Frankenbach and Palmer. The next regular meeting will be held Jan. 23; subject, "Pruning of Trees and Shrubs." U. G. AGER.

MASSACHUSETTS HORTICULTURAL SOCIETY.

There was a good attendance of members at the inaugural meeting of the Massachusetts Horticultural Society, which was held in the lecture hall of the building at noon on January 4.

President Stephen M. Weld occupied the chair and in his inaugural address he said that as a means of increasing the society's income certain improvements might be made in the halls to make them more sought after by tenants. Reference was made to the decoration of one of the halls at a cost of \$1000, which seems to have accomplished its purpose. A committee now has under consideration other changes.

The exhibitions of the year have been of a high standard of excellence. Referring to the last chrysanthemum show, President Weld said the show was hardly as full and complete as had been hoped for, but that measures are under way to insure a greater exhibition than ever next fall. He criticized the last show mildly as being incomplete in its display of chrysanthemums.

Reference was made to a strong difference of opinion existing among the members as to whether cash prizes or medals and vases are most conducive to the horticultural spirit. The president suggested that the matter be given careful consideration. The lectures are of increasing interest and their publication has increased their influence. The interest in horticulture seems to be growing everywhere. It was suggested that the society offer prizes for the plantation of trees, and that idle land be used for this purpose. Relative to the danger to woodland from fire, there should be a more vigorous enforcement of present laws.

Hon. William C. Strong, delegate to the Pomological Convention held at the Jamestown Exposition, reported a good attendance from different parts of the country. A prominent topic for reports and consideration at the convention was the breeding of new varieties by cross-fertilization.

Wilfrid Wheeler reported for the committee on fruit, and stated that the past year was an especially good one for apples, not so much as regards quantity as quality; there was an unusually large crop of strawberries, but not as many pears as usual. Peaches were almost a total failure. Mr. Wheeler recommended that grapes be cultivated more extensively, as they will thrive in almost any soil.

William H. Spooner reported for the State Board of Agriculture to which he was a delegate. Mr. Locke, for the committee on vegetables, gave an encouraging report of the year's developments. Mr. Rich, for the committee on plants and flowers, stated that 617 awards aggregating \$2764 had been made during the year. Numerous other committees also made reports.

SOCIETY OF AMERICAN FLORISTS AND ORNAMENTAL HORTICULTURISTS.

Executive Board Meeting.

Pursuant to call by President Stewart, the executive committee met in special session at Horticultural Hall, Philadelphia, on December 28th. There were present Messrs. Stewart, Elliot, Kasting, Westcott, Beatty, Farquhar, Traendly, Hallock and Rudd. The president appointed Messrs. Robt. Craig and Wm. F. Gude to act in the place of Messrs. Wirth and Murray, who were not present. The president announced that he had appointed W. N. Rudd as secretary to the society, in accordance with the by-laws, to fill the vacancy caused by the death of P. J. Hauswirth, which action was approved by the committee.

President Stewart prefaced his formal announcements of the business before the meeting by a few words, setting forth most feelingly the loss which had been sustained by the society and by the trade at large, through the death of P. J. Hauswirth, and on motion a committee consisting of W. F. Kasting, Frank H. Traendly and Wm. F. Gude was appointed to draw up resolutions, which committee later on presented the following report, which was adopted:

Whereas, We, the Executive Committee of the S. A. F. & O. H., in special session assembled in the city of Philadelphia, Pa., this 28th day of Dec. 1907, have learned of the sad death of our beloved secretary, which occurred in the city of Chicago, on Dec. 4th, 1907; therefore, be it

Resolved, By the Executive Committee of the S. A. F. & O. H., that in the death of Mr. Hauswirth the Society has lost a good worker and a loyal friend.

His motto always was the greatest good to the greatest number, and best interests of all concerned. For time and ability freely given to the best interest of our Society, he stood without a peer. With him the common good was always first; he was ever ready to sacrifice his own interests for those of others. If he had a fault, it was that in his generosity he sacrificed his own interests too much. For time freely given in the best interests of this Society and for the welfare of Horticulture at large, we are indebted beyond expression.

As an acknowledgment of this debt and as a token of grief we feel at his sad death, these resolutions are to be spread upon the records of this Society and a copy sent to his bereaved family.

Signed W. F. KASTING,
FRANK H. TRAENDLY,
WM. F. GUDE.

The president stated that there was a net balance of the society's funds in the hands of the estate of the late secretary amounting to approximately \$1500, and that the family were ready to turn this sum over, but under the advice of their attorney, had asked that a complete check of all society matters, which had been in his hands, should be made in order that there should be no uncertainty. The secretary had deemed this also an eminently proper course to pursue, so that any fears on the part of members of the society, arising through groundless rumors which always are circulated in such unfortunate cases, may be set at rest beyond peradventure.

At the afternoon session Mr. Farquhar was unable to be present, and the president appointed Edwin Lonsdale

ORCHIDS

Largest Importers, Exporters, Growers and Hybridists in the World

**Sander, St. Albans, England
and 235 Broadway, Room 1
NEW YORK CITY**

... ORCHIDS ...

Just to hand, C. Trianae, C. labiata, C. Mossiae, C. Intermedia, C. Schroderae, C. Speciosissima, C. Cirrosa, C. Gaskelliana, Laelia Anceps, L. Albida, L. majalis, L. Autumnalis, Epidendrum Vitellinum majus, E. Cooperianum, Oncidium Crispum, O. Varicosum, O. Cavendishianum, O. Luridum, Odontoglossum Citreum, To arrive in a short time, C. Dowiana, C. Aurea, C. Warmii, Miltonia Vexillaria.

GARRILLO & BALOWIN SECAUCUS, N. J.

ORCHIDS

Just arrived, in fine condition,
Cattleya Trianae (new district).
Oncidium Varicosum Rogersii.

Write for prices.

JOSEPH A. MANDA, 191 Valley Road,
WEST ORANGE N. J.

Write at once for our quotations on all

ORCHID IMPORTATIONS

FOR 1908 DELIVERY

JULIUS ROEHR'S CO.,

The Orchid Nurseries, Rutherford, N. J.

ORCHIDS

We are at present booking orders for freshly imported Orchids for delivery 1908, of all leading kinds at reduced prices. We have just received the following:--
Oncidium Sarcodes, O. Forbesii, O. Tigridum and Sophronites, randi-lora and Coccinea.

LAGER & HURRELL, Summit, N. J.

ORCHIDS

The largest importation of Orchids ever received in this country WILL ARRIVE next spring from Brazil, Colombia and Venezuela. If you intend putting in stock wait for these to arrive and we will quote the Lowest Prices in America.

ORRONEZ BROS., - Madison, N. J.

JAPANESE
THE YOKOHAMA NURSERY CO. NEW YORK.
31 BARCLAY STR.
LILIES
PLANTS
BAMBOO STAKES

to take his place. On motion of Mr. Kasting the flower show committee was authorized to use for awards at the National Flower Show to be held in Chicago, November, 1908, ten silver gilt medals, 25 silver medals, 25 bronze medals, and as many certificates of merit as would be needed for worthy subjects there shown.

The thanks of the members of the committee were then formally tendered to President Stewart for his long services as secretary and president of the Society of American Florists and Ornamental Horticulturists.

President Traendly has appointed Mr. E. V. Hallock of Queens, N. Y., as director, to fill the vacancy on the executive board of the S. A. F. & O. H., occasioned by Mr. Traendly's election as president.

W. N. RUDD Secretary

GOLD MEDAL STRAIN BEGONIAS

TUBEROUS ROOTED

Doz., 100		Doz., 100	
Single White	40c \$2.50	Dbl. White	65c \$5.00
" Yellow	40c 2.50	" Yellow	65c 5.00
" Nanken	40c 2.50	" Orange	75c 5.00
" Pink	40c 2.50	" Rose	75c 5.00
" Rose	40c 2.50	" Dark Rose	65c 5.00
" Red	40c 2.50	" Dark Red	65c 5.00
" Dark Red	40c 2.50	" Red	65c 5.00
" Salmon	40c 2.50	" Salmon	65c 5.00
" Orange	40c 2.50	" Mixed	70c 4.00
" Mixed	35c 2.25		

CALADIUM ESCULENTUM

or Elephant's Ear

	Doz.	100
Size 5x7 inch bulbs	\$0.30	\$2.00
" 7x9 "	.48	3.00
" OVAL "	.85	6.00
" 12 inch and over bulbs	2.40	10.00

GLADIOLUS BULBS

	100	1000	5000
America	\$7.00	\$60.00	\$250.00
Augusta	2.50	20.00	95.00
Brenchleyensis, selected			
1st size	1.50	10.00	47.50
Flay	2.00	15.00	70.00
White and Light	1.50	12.00	57.50
Special Fixed, extra large			
selected bulbs	1.00	8.00	37.50
Tuberose Excelsior			
Pearl, 4x6 — 1st size		9.00	40.00

STUMPP & WALTER COMPANY, 50 Barclay Street, NEW YORK

Seed Trade

The executive committee of the American Seed Trade Association will meet at the Auditorium, Chicago, January 21.

James J. H. Gregory has transferred his seed business at Marblehead, Mass., to his son, Edgar. Mr. Gregory, Sr., is now in his eightieth year.

We mentioned in seed trade notes last week Mr. O. K. Natt. There is no such gentleman; the name is P. K. Nott. "A rose by any other name would smell as sweet."

CATALOGUES RECEIVED.

W. W. Barnard Co., Chicago.—Preliminary List of Florists' Flower Seeds for Early Sowing.

G. S. Crego, Maywood, Ill.—Illustrated folder of the Crego aster, which is described as "the best aster in the market."

Pacific Nurseries, F. Ludemann, Prop., San Francisco, Cal.—Catalogue and Price-list, 1907-1908. A very explicit list of plants, tender and hardy.

W. W. Johnson & Son, Boston, England.—List of novelties and specialties, with wholesale prices to the trade. Vegetable and flower seeds are included.

Haskell Avenue Floral Company, Dallas, Texas.—Roses and Plants for the South. Fills the bill. Colored illustration of Meteor rose adorns the first cover page.

James Vick's Sons, Rochester, N. Y.—Vicks' Garden and Floral Guide, 1908. Chock full, as usual, with good material. The front cover illustration is a trio of Vicks' famed asters in colors.

Conard & Jones Co., West Grove, Pa.—New Floral Guide for 1908. Rose illustrations in colors on cover. This catalogue not only lists roses but a general line of tender and hardy plants.

Felix & Dykhuis, Boskoop, Holland.—Wholesale Catalogue of specialties for nurserymen and landscape architects. Also "The Paeonia," a descriptive list of over three hundred varieties of P. sinensis, phloxes, irises, etc.

California Nursery Company, Niles, Cal.—Catalogues and Price-list of Fruit and Ornamental Trees, Palms, Roses, etc., for 1907-1908. This company has 500 acres under cultivation and the present is the 23rd edition of their catalogue.

Sluis & Groot, Enkhuizen, Holland.—

General Wholesale Price-list of Vegetable, Flower and Agricultural Seeds. Includes a colored plate of Tropaeolum Lobbianum Queen Wilhelmina; flowers scarlet and foliage creamy-white, marbled and veined.

W. E. Marshall & Co., New York City.—Seed Catalogue for Spring, 1908. The Countess of Lonsdale dahlia forms the first cover page illustration, and Black Valentine bean the last. The contents are comprehensive and include a good novelty list.

A. Mitting, Santa Cruz, Cal.—Wholesale Price-list for Florists and Nurserymen. Frontispiece, a cut of Superlative raspberry, a European introduction said to produce berries three times as large as any known raspberry and to be a continuous cropper.

Henry F. Michell Co., Philadelphia, Pa.—1908 Wholesale Catalogue for Florists and Market Gardeners. This has the characteristic Michell business ring in every one of its fifty pages, and the florist or market gardener who does not send for a copy should be fined.

W. W. Rawson & Co., Boston.—Garden Manual for 1908. A belle toying with a bunch of Canterbury Bells for the edification of an elderly gentleman in the window, forms an expressive frontispiece. The book is a McFarland production which sufficiently fixes its merit as a typographical and pictorial attraction.

David Herbert & Son, Atco, N. J.—1908 Descriptive Catalogue of Dahlias, for seedsmen, florists, nurserymen and dealers. This is a very desirable list for those who wish to learn about the new and rare varieties and the best of the standard sorts. The collection represented is undoubtedly the largest in this country.

W. Atlee Burpee & Co., Philadelphia, Pa.—Burpee's Farm Annual, containing "the plain truth about the best seeds that grow." Unique New Fordhook Bush Lima Bean distinguishes the front and a group of brilliant sweet peas the back cover page. Spencer sweet peas, new nasturtiums, Fordhook musk melon and Wayahead lettuce are the subjects of colored inserts.

J. M. Thorburn & Co., New York City.—Seed Catalogue, 1908. A high-class catalogue in every respect. The cuts are beautiful and the arrangement of the text convenient, creditable alike to compiler and printer. The light, creamy brown cover is embossed, the first page showing a garland of asters in colors and the last page a cluster of

carnations. Thorburn's Trade List comes by same mail. It is a business proposition from cover to cover.

H. A. Dreer, Inc., Phila., Pa.—Dreer's Garden Book, 1838-1908.—This is the seventieth anniversary edition of this old but ever young friend of the flower and garden lover. No attempt at sensational effect is made on the covers, which are dark green with no ornament other than the inscription in gold embossed letters, but there are four handsome colored inserts—garden vegetables, pansies, cannas and paeonies respectively—and the pages are well filled with readable descriptive matter as usual.

"Everything for the Garden," by Peter Henderson & Co., New York, is

MICHELL'S SEEDS
Are Always Reliable.
1018 MARKET ST. PHILA.
WHOLESALE CATALOGUE FREE

GLADIOLI
I can satisfactorily supply your wants for Gladioli for forcing or outdoor planting. Mixtures, color sections or named varieties of exceptional beauty.
Write for Prices
ARTHUR COWEE
Gladiolus Specialist
Meadowvale Farm, BERLIN, N. Y.

HYACINTHS, TULIPS, NARCISSI AND OTHER BULBS
ROMAN HYACINTHS and the true PAPER WHITE GRANDIFLORA
Ask for our Wholesale Trade List at Hillegom
K. VELTHUYS, Hillegom, Holland
Rep. by **FELIX BOSCH, 260 Clarendon St., Boston**

an annually welcome visitor to our desk. The edition for 1908, just received, is if possible better than any of its predecessors, every square inch of space filled with illustration or descriptive matter calculated to make the average mortal yearn for the spring time to come and the privilege of filling out the order sheet. The cover is white with gold embossed letters and, apparently seen through a lattice work, is a garden scene in bright colors, a very effective arrangement.

Kelway & Son, Langport, Somerset, England.—Kelway's Manual of Horticulture, for 1907-1908. This volume of four hundred pages, the largest publication of its class which we have seen, is teeming with interesting reading matter and superbly illustrated. A lovely colored plate of herbaceous paeony Queen Alexandra forms the frontispiece. A group of new delphiniums is the subject of another colored illustration. This useful book is a Manual in fact, and will be found invaluable especially by the lover of hardy herbaceous plants. Messrs. Kelway are to be complimented on their enterprise in sending out so fine a work.

Cover your Cold Frames with HOT BED MATS

Made of burlaps, thickly quilted with jute making a serviceable warm mat. 76 x 76 inches, will cover two frames.

\$1.25 each. \$14.00 per doz.

WM. ELLIOTT & SONS
201 Fulton St., NEW YORK.

WIBOLTT'S SNOWBALL CAULIFLOWER-SEED
is the earliest of all Snowballs, the most compact, the surest header, is giving the largest and snow-whitest heads, and is the best keeper in dry-weather. Demand it through your seed-firm or direct from
R. WIBOLTT, NAKSØY, DENMARK



Cyclamen
Superb English Strain
Second to none in size of flowers
Giant Crimson.
" Pink
" White.
" White with Claret base.
" Mauve.
" Salmon Queen.
" New Fringed.

100 seeds \$1; 1000 seeds \$9.

H. E. FISKE SEED CO.
12 and 13 Fanueil Hall Square, BOSTON MASS.

CAULIFLOWERS & CABBAGE SEED
HJALMAR HARTMANN & CO.,
12 Stormgade, COPENHAGEN, DENMARK.

ESTABLISHED 1802
Thorburn's Seeds

Send for our Wholesale Catalogue of Seeds for Florists and Market Gardeners, ready in a few days.

	Per doz.	Per 100
GLADIOLUS PRIMULINUS	\$8.00	\$60.00
PRIMULINUS HYBRIDS	3.00	20.00

J. M. THORBURN & CO.
33 Barclay St., through to 38 Park Place
NEW YORK

Everything of the Highest Grade

"QUALITY IS REMEMBERED LONG AFTER PRICE IS FORGOTTEN."
WHAT QUALITY MEANS.
Quality means the best and finest types procurable in their respective classes. We go to specialists for our flower seeds. Our customers, the Florist the private gardener demand the highest grade. We have no cheap catalogue trade. "Quality" may mean a little higher in price. "Quality" in fact means "Quality" and we know that when you buy from us you get it;—and our customers know it too. Catalogue now in press; 40 pages. Write for one its FREE. We sell bulbs too.
ARTHUR T BODDINGTON,
SEEDSMEN
342 West 14th St., NEW YORK.

BRASLAN SEED GROWERS CO.
GROWERS FOR THE
WHOLESALE TRADE ONLY
SAN JOSE, - - CALIFORNIA
Burpee's Seeds
PHILADELPHIA

Blue List of Wholesale Prices mailed only to those who plant for profit

Lily of the Valley
Finest Berlin \$12.00 per 1,000
BRIDGEMAN'S SEED WAREHOUSE
RICKARDS BROS.
Props.
37 East 19th St., - NEW YORK CITY

C. C. MORSE & CO.
Address all communications to our permanent address
48 to 56 Jackson St., San Francisco, Cal.
The Largest Seed Growers in the United States

BAMBOO CANES TOUGH AND STRONG
6 ft. long—\$1 per 100; \$6 per 1000; \$11 per 2000
They cost about 10 per cent. more than other kinds, and they are 10 times better.
STUMPP & WALTER CO., - 50 Barclay St., New York

RELIABLE SEEDS
SOW NOW

	Tr. Pkt.	6 Tr. Pkts.
Alyssum Carpet Queen, real dwarf for pots only, no equal.....	\$0.25	\$1.25
Begonia (Gracilis Luminosa, new Erfordia, beautiful.....	0.50	2.50
Zangen's Bedding Queen	0.50	2.50
Lobelia, new Frailing Hamburga	0.30	1.50
Petunia, Zangen's Extra Double Fringed Giants.....	1.00	5.00
Zangen's Superb Single Fringed Giants.....	0.75	4.00
Zangen's Ruffled Giants, the best.....	1.00	5.00
Phlox, best for pots, Fireball, Roseball, Snowball, each color.....	0.25	1.25
Salvia Fireball, new, a fine potter	0.50	2.50
Stocks, German 10 weeks: Blood-red, Lavender, Pink, Purple, White, each color.....	0.50	2.50
Verbena Mammoth: Pink, Purple, Scarlet, Striped, White, each color.....	0.25	1.25

My New Fall List Ready for the Asking
O. V. ZANCEN
Seedsman. HOBOKEN, N. J.

Best Quality Fall Bulbs
It is to your advantage to place your order early. Send us a list of your wants and we will quote you rock-bottom prices. Copy of our Florists' Bulb Catalogue will be sent upon request. Catalogues now ready.

VICK'S SUPERB PANSY SEED
All the best varieties in separate colors
VICK'S SUPERB MIXTURE
the best strain from all the leading named sorts
1-8 oz. 75c. 1-4 oz. \$1.50 Ounce \$5.00
JAMES VICK'S SONS, Rochester, N. Y.

CYCLAMEN
Farquhar's Giant Strain
Unsurpassed for size of flowers.
Giant Crimson Giant Pink
Giant White Finest Mixed
Giant Excelsior, White with Claret Base
100 seeds, \$1.25; 1000 seeds, \$10.00.
R. & J. FARQUHAR & CO.
6 & 7 So. Market St., Boston, Mass.

BRECK'S SEEDS
For Farmer, Market Gardener and Florist
New Crop High Grade
Catalogues mailed free on application
Joseph Breck & Sons Corp.
47-54 NO. MARKET ST., BOSTON, MASS.

JUST ARRIVED
LARGE SHIPMENT OF
High-Grade SCOTCH SOOT.
We have the Stott Double Nozzle
THOMAS J. GREY CO.
32 & 33 So. Market St., BOSTON

FLORIST CLUB OF PHILADELPHIA.

The monthly meeting of this club held on the 7th inst. was notable for the excellent exhibits of new roses and carnations. R. Witterstaetter staged a fine vase of carnation Afterglow; Fred Dorner, Sons & Co., sent fifty blooms of Winona, a light rose, showing great promise. John E. Haines was on hand with Imperial, Pink Imperial and a number of new seedlings. John Kuhn showed his new dark pink seedling. In roses the Rhea Reid from E. G. Hill Co. was conspicuous. Robert Scott & Sons sent a fine vase of their new star, Mrs. Jardine. From Poehlman Bros. came Mrs. Potter Palmer, the first time this variety has been exhibited here. Adolph Farenwald sent his new Aurora, a cross between Carnot and Bon Silene, something after the form and color of Chateau; Kate Moulton showing excellent culture, and a lot of Killarneys; the latter, however, had to take a back seat when compared with the magnificent blooms of the same variety from the Waban Rose Conservatories. Mr. Farenwald thinks the soil, or climate, or both, around Boston must have something to do with the superiority of the Killarneys grown there. Mr. Fancourt explained to the members that the Waban Killarneys were the ordinary flowers as sent to market, and had not been grown or selected specially for exhibition. Myers and Samtman sent their new pink, Wyndmoor, and Mr. Samtman was kept busy explaining its origin and merits. Bruno Schroeter of Detroit exhibited a grand lot of White Enchantress carnation, and a new white snapdragon, both showing excellent culture. S. S. Skidelsky was the essayist of the evening, his subject being "Competition—Fair and Foul," which he handled in his usual able and scholarly manner. The next meeting, first Tuesday of February, will be devoted specially to the carnation. Exhibits are requested.

FLORISTS' CLUB OF WASHINGTON.

The regular monthly meeting was held at Gude's Hall on the night of Jan. 7th inst. This is the first time that Pres. Bisset has presided at a meeting since his return from Porto Rico, and all were more than glad to find him so much improved in health. The chief subject of interest was the approaching carnation show. The meetings will be held at National Rifles Armory, but the final details have not been perfected, and there will be a special meeting called beforehand to settle all minor matters. Jan. 29th will be known as "Carnation Day" and all growers of carnations are earnestly requested to donate flowers as there will be 25,000 of them given away on that day. On the afternoon of the 30th it is purposed, if possible, to have a drill by the artillery and cavalry at Fort Myer in honor of the visiting florists. On the evening of the 30th there will be a banquet. Suitable resolutions were drawn up on the death of John Clark, who with his entire family recently perished in a fire in his home in Watertown, Mass. A copy of the resolutions will be sent

EXTRA FINE BOXWOOD \$17.50 per CWT.

**FANCY FERNS, A No. 1 Quality, \$1.50 per 1000
GREEN CALAX \$1 per 1000, \$7.50 per 10,000
BRILLIANT BRONZ \$1 per 1000, \$8.50 per 10,000**

Headquarters for HARDY FERNS, MOSS, LAUREL, PRINCESS PINE, FESTOONING, Etc.

HENRY M. ROBINSON & CO., FLORISTS' SUPPLIES **15 Province St., and 9 Chapman Pl., BOSTON**

his father, John T. Clark, who has a position at Botanic Gardens.

Mr. Burns, of Agricultural Department, had on exhibition about two dozen fine seedling carnations, which were favorably received.

CLUB AND SOCIETY NOTES.

The annual meeting of the Southern Minnesota Horticultural Society will be held at Albert Lea, January 14-15.

At the annual meeting of the Minnesota State Agricultural Society, to be held at St. Paul January 14-16, about \$500 will be offered as premiums for the best displays of grain seed.

The Toledo Florists' Club meeting on December 26th had a holiday attendance and no business of note was accomplished, but a jolly good time was had among those who were there.

The inaugural meeting of the New York Florists' Club will be held on Monday evening, January 13. It will be a brilliant gathering. All the nobility and talent of the club will be present to see President Weathered grasp the gavel.

On Tuesday evening, January 21, the Gardeners' and Florists' Club of Boston will hold Ladies' Night. President Westwood has set his heart on making this a memorable event and the committee in charge are unanimously of the same mind, and that settles it.

NEWS NOTES.

At the recent exhibition of the Winter Flowering Carnation Society in London, England, carnation Aristocrat was awarded first prize in the deep-pink class.

The Daily News, of Newport, R. I., has published several articles recently on the subject of children's school gardens, and all of them have the proper ring.

Stump & Walter Co., New York, are sending out a folder telling about the Auto-Spray with which they say everybody ought to spray. Now is a good time to buy this excellent sprayer.

J. L. Loose of Alexandria, Va., has recovered \$20,000 damages from the Southern Railway Company for the destruction of plants and flowers by smoke issuing from the defendant's premises.

GALAX FROM FIRST HANDS

GALAX { Bronze, small to med. size.....35c 1000
" medium size.....40c 1000
" large size.....45c 1000
Green, medium size.....40c 1000
" large size.....45c 1000

Terms: Strictly cash, f.o.b. Galax, Va.
W. M. WOODRUFF & SON, Lowgap, N. C.

BOSTON FLORIST LETTER CO.
Manufacturers of FLORISTS' LETTERS



This wooden box nicely stained and varnished, 18x30x12, made in two sections, one for each size letter, given away with first order of 500 letters.
Block Letters, 1/2 or 2 inch size per 100, \$2.
Script Letters, 3/4. Fastener with each letter or word. Used by leading florists everywhere and for sale by all wholesale florists and supply dealers.
N. F. McCARTHY, Manager
66 Pearl Street, BOSTON, MASS.

BOXES BOXES BOXES
LIGHT WOOD CUT FLOWER BOXES
Sizes in Stock per 100

3 x 4 x 20	\$4.00
3 x 5 x 24	4.50
3 x 7 x 21	4.50
6 x 6 x 24	6.80
4 x 12 x 24	9.00
6 x 12 x 24	10.50
6 x 12 x 30	12.50
5 x 12 x 36	14.00
6 x 12 x 36	15.00
6 x 15 x 42	20.00
6 x 15 x 48	23.00

Write for samples and prices in car load lots.
GETMORE BOX FACTORY, Incorporated,
BELLEVILLE, ALA.

The "Japan" Cut Flower Holder

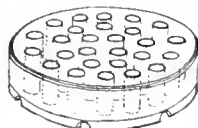

A handy article for florists. Sells to the trade on sight. Made of glass in three sizes. The "Anglials" Table Decoration, something entirely new, long needed. The florist and housewife will appreciate this article, as it simplifies the art of table decorating.
Ask for catalog.
M. V. CARNSEY, Dept. J,
130 Waiola Ave., La Grange, Ill.

KORAL SCRIPT LETTERS AND EMBLEMS
ONCE USED ALWAYS USED
For sale by all first class supply houses. Made by
KORAL MFG. CO.
26 Hawley St., Boston

E. A. BEAVEN
Southern Wild Smilax, Log Mosses,
Natural and Perpetuated — at Wholesale,
EVERGREEN, ALABAMA.
In ordering goods please add, "I saw it in HORTICULTURE."

**JOHN BREITMEYER'S
SONS**
Cor. Miami and Gratiot Aves.
DETROIT, MICH.
**Artistic Designs . . .
High Grade Cut Blooms**
We cover all Michigan points and good
sections of Ohio, Indiana and Canada

P. J. HAUSWIRTH
232 Michigan Ave.
CHICAGO
AUDITORIUM ANNEX Tel. Harrison 585

**SAMUEL MURRAY
Florist**
Coates House Conservatory
1017 BROADWAY, KANSAS CITY, MO
Both 'Phones 2670 Main

**FRED C. WEBER
FLORIST**
4326-28 ST. LOUIS, MO.
OLIVE STREET
Established 1873
Long Distance Phone Bell Lindell 676



WASHINGTON,
D. C.
GUDE'S
GUDE BROS CO
FLORISTS
1214 F ST NW
WASHINGTON DC

**Geo. H. Cooke
FLORIST**
Connecticut Avenue and L Street
WASHINGTON, D. C.

The Park Floral Co.
J. A. VALENTINE
Pres.
DENVER, COLORADO

**WILLIAM L. ROCK
FLOWER CO.**
KANSAS CITY, - MO.
will carefully execute orders for Kansas City
and any town in Missouri or Kansas.

ALBANY, N. Y.
EYRES
Flowers or Design Work
DELIVERED IN ALBANY AND VICINITY
ON TELEGRAPHIC ORDER.
11 NORTH PEARL ST., ALBANY, N. Y.

NEWS NOTES.

D. H. Maggart of Salem, Ore., has started in the florist business at Elmhurst, Cal.

Albert Zepf has returned to Vincennes, Ind., and will start in the florist business there.

It is stated that the Braidwood Floral Co. of Colorado Springs, Colo., is in financial difficulties.

The tournament of roses was held at Pasadena, Cal., Jan. 1. It is said that 50,000 visitors were present.

The Longview Floral Co. is the name of a new concern starting in business at 2520 Elma avenue, Kansas City, Mo.

A. E. Lemke, florist, St. Paul, Minn., has filed a petition in bankruptcy. A meeting of creditors was held on Jan. 3.

Fire, which evidently originated in the boiler room, destroyed the small greenhouse and other property belonging to James Dennington, Bridgeton, N. J., on Dec. 31. The loss is about \$400.

D. J. Mackintosh, 1144 Broadway, New York, has filed a petition in bankruptcy; liabilities, \$8,780; assets, \$4,496, including about \$3,500 in uncollectable accounts.

NEW RETAIL FLOWER STORES.

Richard Coats, Indianapolis, Ind.
A. Rolleri, 7th and Clay streets, Oakland, Calif.

LEADING RETAIL FLORISTS—
Index by Towns will be found in Buyers' Directory.



**Hoffman
FLORIST**
59-61
Massachusetts Ave.
Commonwealth Ave.
BOSTON.

**PROMPT DELIVERY IN
BOSTON**
AND ALL NEW ENGLAND POINTS
HOUGHTON & CLARK
396 Boylston St., Boston, Mass.
Send flower orders for delivery in
BOSTON
and all
NEW ENGLAND POINTS
THOS. F. GALVIN
124 Tremont St., Boston

TRANSFER
Your orders for flower or plant delivery in
Eastern New England to
JULIUS A. ZINN,
2 Beacon St., Boston.
Fine Design Work a Specialty

ATLANTA FLORAL CO.
41 Peachtree Street, ATLANTA GEORGIA.

Florists Out of Town

Taking orders for delivery in
New York or Vicinity
can have them filled in best
manner and specially deliv-
ered by

Thomas Young, Jr.

41 W. 28th St., New York City

ALEX. McCONNELL
571 FIFTH AVENUE
NEW YORK CITY
Telegraphic orders forwarded to any
part of the United States, Canada, and
all principal cities of Europe. Orders
transferred or intrusted by the trade to
our selection for delivery on steamships
or elsewhere receive special attention.
Telephone Calls, 487 and 488 38th St.
Cable Address, ALEXCONNELL

WILLIAM H. DONOHOE
FLORAL DECORATOR
17 East 28th St., New York
Special Attention to Theatre
and Steamer Orders, and reliable
deliveries guaranteed.

DAVID CLARKE'S SONS
Deliver orders from any part of the country to
New York City
Or OUT-GOING STEAMERS
Write or telegraph
2139-2141 Broadway, New York
Telephone 1552-1553 Columbus

A. WARENDORFF,
1193 Broadway,
NEW YORK.

Send your orders to the King of Floral Artists.

Flower Deliveries
In Brooklyn and other Long Island Points
New York City, New Jersey etc. At Theatres,
Hotels, Steamers or Residences.
WILSON
Fulton St. and Greene Ave., Brooklyn, N. Y.

YOUNG & NUGENT
42 West 28 St., NEW YORK
"FLOWERS BY TELEGRAPH"

**William J. Smyth
FLORIST**
Cor. Michigan Ave. and 31st St., CHICAGO
We ship to all points in Illinois and Iowa.
Phones: Douglas 744, Douglas 523, Douglas 740

JACOB SCHULZ, 644 Fourth Ave.,
LOUISVILLE, KY.
Cut Flowers of BEST QUALITY in season
delivered promptly to any address.
Write, Telegraph or Telephone.
Cumberland and Home Phones 223 and 984

CARNATIONS — Rooted Cuttings

Healthy, well-rooted stock the product of the most reliable growers of this locality

	Per 100	Per 1000		Per 100	Per 1000		Per 100	Per 1000
White Enchantress,	\$6.00	\$50.00	Enchantress,	\$2.50	\$20.00	Harlowarden,	\$2.00	\$20.00
White Perfection,	3.00	25.00	Helen Goddard	2.50	24.00	Patten,	2.50	20.00
White Lawson,	2.00	18.00	Lawson,	2.00	18.00	Fenn,	2.00	18.00
Queen Louise,	2.00	18.00	Beacon,	6.00	50.00	Red Sport,	2.00	18.00
Winsor,	6.00	50.00	Victory,	3.00	25.00	Boston Market,	2.00	18.00
Aristocrat,	6.00	50.00	Craig,	3.00	25.00	Joost,	2.00	18.00
Rose Pk Enchantress,	3.50	30.00						

NEW CROP SEEDS
ASPARAGUS PLUMOSUS NANUS \$4.50 per 1000.
 Special prices on large quantities. Greenhouse Grown, Hard Selected

CUT BOXWOOD, 50 lb. cases, \$15.00 per 100 lbs.
POINSETTIA, extra value, \$15.00 and \$25.00 per 100 lbs.

S. S. PENNOCK-MEEHAN COMPANY, "THE" Wholesale Florists of **PHILADELPHIA**
 1608-1620 Ludlow Street, - - - - -

EVERYTHING SEASONABLE IN
CUT FLOWERS
EDWARD REID, Wholesale Florist
 1526 Ranstead St., PHILADELPHIA
 STORE CLOSES 3 P. M.

CHAS. W. McKELLAR
 51 WABASH AVE., CHICAGO
 Western Headquarters for Choice Orchids
 Valley, Roses and all Cut Flowers

PETER REINBERG
 WHOLESALE
CUT FLOWERS
 51 Wabash Av., Chicago, Ill.
 In writing advertisers mention Horticulture

CUT FLOWER BOXES
EDWARDS FOLDING BOX CO
 MANUFACTURERS
 PHILADELPHIA, PA.

AMERICAN BEAUTY and all other **ROSES**
LILY OF THE VALLEY, CARNATIONS
WELCH BROS., 226 Devonshire St., Boston, Mass.

TRUMPET MAJORS
 Extra Quality Any Quantity
W. E. McKISSICK WHOLESALE FLORIST
 PHILADELPHIA
 1619-1621 RANSTEAD ST.

WHOLESALE FLOWER MARKETS
 TRADE PRICES—Per 100—TO DEALERS ONLY

	CHICAGO Jan. 4	TWIN CITIES Dec. 31	PHILA. Dec. 31	BOSTON Jan. 9
ROSES				
Am Beauty, Fancy and Special...	30.00 to 50.00	40.00 to 75.00	60.00 to 75.00	40.00 to 50.00
" Extra.....	30.00 to 40.00	40.00 to 75.00	40.00 to 50.00	20.00 to 30.00
" No. 1.....	15.00 to 25.00	30.00 to 40.00	20.00 to 30.00	10.00 to 15.00
" Lower grades.....	8.00 to 10.00	20.00 to 30.00	8.00 to 15.00	6.00 to 8.00
Bride, 'Maid, Fancy & Special....	8.00 to 10.00	10.00 to 12.00	12.00 to 15.00	10.00 to 12.00
" Extra.....	6.00 to 7.00	8.00 to 10.00	8.00 to 10.00	6.00 to 8.00
" Lower grades.....	3.00 to 5.00	6.00 to 8.00	5.00 to 6.00	2.00 to 4.00
Killarney, Richmond, Fau. & Sp....	8.00 to 15.00	10.00 to 20.00	15.00 to 20.00	12.00 to 15.00
" Lower grades.....	6.00 to 7.00 to 6.00	6.00 to 10.00	4.00 to 6.00
Chatenay, Wellesley, Fau. & Sp....	8.00 to 12.00	10.00 to 20.00	15.00 to 20.00	12.00 to 15.00
" Lower grades.....	3.00 to 6.00	6.00 to 8.00	6.00 to 10.00	6.00 to 8.00
Golden Gate, Ivory.....	5.00 to 8.00	10.00 to 20.00	5.00 to 10.00	6.00 to 8.00
CARNATIONS				
Fancy and Novelties.....	4.00 to 5.00	12.00 to 18.00	5.00 to 6.00	4.00 to 5.00
Ordinary.....	2.00 to 3.00	6.00 to 10.00	3.00 to 4.00	2.00 to 3.00
MISCELLANEOUS				
Violets.....	.75 to 1.00	2.00 to 3.00	1.00 to 1.50	.50 to .75
Cattleyas.....	40.00 to 50.00	60.00 to 75.00	50.00 to 60.00	40.00 to 50.00
Cypripediums.....	12.00 to 17.00	15.00 to 25.00	12.00 to 15.00	10.00 to 12.00
Lilies.....	12.00 to 20.00	15.00 to 20.00	12.00 to 15.00	10.00 to 16.00
Lily of the Valley.....	3.00 to 5.00	4.00 to 5.00	3.00 to 5.00	2.00 to 4.00
Roman Hy., Paper White Nar.....	2.00 to 3.00	4.00 to 5.00	2.00 to 4.00	1.00 to 2.00
Poinsettias..... to 45.00 to 60.00	15.00 to 25.00 to 30.00
Stevia..... to 1.50	2.00 to 3.50	2.00 to 2.50	1.00 to 1.50
Mignonne.....	3.00 to 8.00	4.00 to 5.00	4.00 to 8.00	3.00 to 6.00
Chrysanthemums..... to 1.00	1.50 to 2.00	1.00 to 1.50	1.00 to 1.50
Adiantum.....	.75 to 1.00	1.50 to 2.00	1.00 to 1.50	1.00 to 1.50
Whitmanii Fronds.....	15.00 to 25.00	4.00 to 5.00 to 4.00	1.00 to 2.00
Smilax.....	12.00 to 15.00	15.00 to 20.00	12.00 to 15.00	12.00 to 16.00
Asparagus Plumosus, strigosa.....	35.00 to 50.00	40.00 to 65.00 to 50.00 to 50.00
" " & Spreng. (too heavy).....	35.00 to 50.00	40.00 to 65.00	35.00 to 50.00 to 50.00

DAILY CONSIGNMENTS
 From 40 to 60 Growers
 We can care for your cutflower wants to advantage.
E. F. WINTERSON CO.
 45-47-49 WABASH AVE., CHICAGO

ROBERT J. DYSART,
 Public Accountant and Auditor
 Simple methods of correct accounting especially adapted for florists' use.
 Books Balanced and Adjusted
 Merchants Bank Building
 28 STATE ST., BOSTON
 Telephone, Main 38

THE FLORISTS' SUPPLY HOUSE OF AMERICA

Without a rival in knowledge of the requirements of the trade and the ability to supply them. Our New Illustrated Catalogue, recognized as a work of art unprecedented in its line for variety, novelty and completeness, tells the story fully, and if you have not yet sent for it, do so now.

'TIS FREE TO EVERYBODY IN THE TRADE

H. BAYERSDORFER & CO., 1129 Arch St., Philadelphia, Pa.

To Cut Flower Growers and Retail Florists

IF YOU

want to find a market for your product
want a regular or special supply of the product of the best growers

Consult the Advertisements on these Wholesale Flower Pages

The Advertisers Represented Here are the Leading Concerns in the Wholesale Flower Trade

A Fine Assortment of
==AZALEAS==

Extra fine lot of **FIREFLY** in bloom from

CHRISTMAS to EASTER

WRITE FOR PRICES

MAJOR BONNAFFON

The best all 'round Yellow Chrysanthemum. Strong stools,
\$5.00 per 100

W. W. EDGAR CO., Waverley, Mass.

FLOWER MARKET REPORTS

BOSTON Quiet prevails in the business here since New Year's, and on some lines accumulations are imminent. Taking the leading specialties in order, it may be said that roses are not overplentiful, and all varieties and grades find a fair sale excepting high-grade American Beauties, which in the presence of high-grade Richmonds at one half the traditional Beauty price have to take a back seat, and it does look as though the Beauty was definitely slated for lower prices henceforth. Carnations have shifted their lines and it is no longer the bright colored sorts but the whites that hold precedence. Violets are plentiful and are moving rather reluctantly. All bulbous stock is slow and accumulating in wholesalers' hands. Some yellow narcissi are in and sell at \$2.00 to \$3.00 per 100 when a buyer shows up, but Paper White at its worst sells in the proportion of ten to one as compared with the yellow trumpets at this early date. Lily of the valley is still in the dumps. Too many are being grown for this market at present.

BUFFALO Trade was rather quiet the past week; in fact very little doing. Had it not been for a sprinkling of floral work and one or two pink teas the florists would have had a winter vacation. Stock has not been too plentiful, though enough so to fill all orders. Sweet peas have been a little short in supply and the same may be said of Beauties, the quality being fine. All bulbous stock is in good supply.

DETROIT Truly a great finish for the old year, is the only way local business conditions can be described. Every scrap of flower found its purchaser. As the end so was the whole of 1907—good prices, no surplus stock, and a regular demand were the principal characteristics of 1907, and if anyone did not fully realize and get all the good there was in it he must blame more himself than any other agency. We are fortunate here in not being bothered with any serious price cutting and what little there was was entirely un-called for, but such will be always more or less. Several fakery tried this trick here, but a scant supply and less demand caused them to withdraw as poorer but wiser men. In the

better stores carnations find easy sales at \$1.50 to \$2.00 per doz. Roses retail from \$2.00 to \$12.00 for best American Beauties and violets at \$3.00 to \$4.00 per hundred.

INDIANAPOLIS Since Christmas there has been a fairly steady demand and the total of sales has been satisfactory. The supplies of stock have been such that prices were not maintained as they usually are between the holidays. Beauties and teas are of good quality but not in extra heavy supply. Carnations are abundant and of splendid quality. Unless we get too much dark weather there is not apt to be any shortage of stock in most lines as long-delayed crops seem to be on. There was a good demand for violets at New Year's which were of good quality. All requirements can be now met with in lilies, lilacs, lily of the valley and bulbous stock in general. Paper Whites seem to be a glut and are selling below the market price. Sweet peas, daffodils and tulips sell well but are to be had in limited quantities only. New Year's did not develop any special demand and as to trade will compare favorably with last year.

NEW YORK Business in the wholesale district is very slow and prices are falling daily. No special flower seems to have much lead in the demand, all suffering more or less from the inactivity which has prevailed since New Year's. Bulbous stock and lily of the valley are perhaps in poorest luck and all green goods keep them company. The drop in values since New Year's averages about 25 to 35 per cent. The drop was not immediate but has been gradual from day to day. A renewal of activity will be most welcome and it cannot come too soon.

PHILADELPHIA A shortening up of receipts helped the situation here considerably last week. The cooler weather has had a very good effect all round, especially in the rose crops. Carnations have not been affected to quite the same extent. But, generally speaking, a much better tone prevails. While American Beauty is in shorter supply there is still plenty for demand. Brides and Bridesmaids show decided improvement as to quality, the flowers

being much firmer, heavier and of better color. Campbell and Princess remain the leaders in violets. The lily of the valley market has improved a little and has now some snap to it. The only change in the orchid situation is the advent of some very fine shipments of *Cypripedium Leeatum*.

TOLEDO Christmas and New Year's business was about the same as last year. Where the florists in the better neighborhoods did more business, those in the working quarters did less, as a good many factory hands had been out of work for several weeks. Flowers were not over plentiful and more could have been used; everything was cleaned out nicely. Our stores were all fairly well decorated, but nothing very elaborate. The only flower that did not sell as expected for Christmas was the poinsettia, but they went off nicely after Christmas. Carnations are now more plentiful and quality is good; roses are not grown largely here, but what there are show good quality.

WASHINGTON A terrific wind, rain and sleet storm held Washington in an icy clutch for more than twelve hours on Jan. 7th. Cloudy weather followed, which has been a menace to the crops. Everything in the cut flower line is scarce and in great demand, and prices keep up. Everywhere the working force is diminished by grippe, which has been a dreadful epidemic in Washington since two weeks before the holidays. We hope that the present year which has just been ushered in has pleasanter and healthier things in store for us all at a very early date.

BUSINESS CHANGES.

The Simon greenhouses at Easton, Pa., have been leased by Fred Munz.

Mrs. Scallen is carrying on the business, formerly of Charles Scallen, at 42d St. and Broadway, New York, which was recently disposed of by sheriff's sale.

The KERVAN CO. 113 W. 28th St. New York

WHOLESALE DEALERS
Fresh cut Palmetto & Cycas Palm Leaves, Ferns, Lichtholze Ferns and Mosses. All Decorating & Evergreen

JOHN YOUNG
WHOLESALE FLORIST
 Finest American Beauties and
 Carnations
 51 West 28 St. - NEW YORK

FORD BROTHERS
 48 West 28th Street, NEW YORK
FINE ROSES FANCY CARNATIONS
 A Full Line of ALL CUT FLOWERS
 Telephone, 3870 or 3871 Madison Square

H. E. FROMENT,
 Wholesale Commission Florist,
 Choice Cut Flowers,
 57 West 28th St., :: NEW YORK.
 Telephones: 2200, 2201, Madison Square.

The Reliable Commission House
 Richmond Roses and Rich Flowers
 of all varieties
JOS. S. FENRICH
 110 W. 28th Street, New York
 Tel. 324-325 Madison Square

Established 1891 BUY FROM SHIP TO TRY **ME**
ALFRED H. LANGJAHR
 All Choice Cut Flowers in Season
 55 West 28th St., New York
 Telephone 3024 Madison Square.

JOHN I. RAYNOR
Wholesale Commission Florist SELLING AGENT FOR LARGEST GROWERS
 A full line of Choice Cut Flower stock for all purposes. Comprises every variety grown for New York market, at current prices
 TEL. 1998 MADISON SQUARE 49 W. 28 St., New York City

Walter F. Sheridan
 Wholesale Commission Dealer in
CHOICE CUT FLOWERS
 39 West 28th Street, New York
 Telephone: 3532-3533 Madison Square

HEADQUARTERS FOR NOVELTIES
ORCHIDS A SPECIALTY
 THE HIGHEST GRADE OF **VALLEY** ALWAYS ON HAND
 GARDENIAS, DAISIES, ROSES AND CARNATIONS
JAMES McMANUS, Telephone 759 Mad. Sq. 42 W. 28th St., New York

PHILIP F. KESSLER 55 & 57 W. 26th St., New York City
 Commission Dealer, Wholesale Buyer and Seller of
CUT FLOWERS
 Open from 5 a. m. to 6 p. m. Sunday till 10 a. m.
 Tel., 5243 and 2921 Madison Sq. Res., 345 J., Newtown.
Finest Lilies in the Market Every Day in the Year.

WHOLESALE COMMISSION FLORIST **J. K. ALLEN** 106 W. 28 ST. NEW YORK
 Telephone 167 Madison Sq.
 OPEN 6 A.M. DAILY
 We have a good regular outlet for seasonable flowers

NEW YORK QUOTATIONS PER 100—TO DEALERS ONLY

	Last Half of Week ending Jan. 4 1908	First Half of Week beginning Jan. 5 1908	Last Half of Week ending Jan. 4 1908	First Half of Week beginning Jan. 5 1908
Roses				
Am. Beauty, fan and sp.	10.00 to 15.00	50.00 to 20.00	25.00 to 10.00	50.00 to 20.00
" extra	15.00 to 10.00	20.00 to 15.00	10.00 to 8.00	20.00 to 15.00
" No. 1	10.00 to 5.00	15.00 to 10.00	8.00 to 1.00	15.00 to 2.00
" Lower grades	5.00 to 1.00	10.00 to 5.00	1.00 to 8.00	2.00 to 12.00
Bride, 'Maid, fan and sp.	10.00 to 7.00	12.00 to 8.00	8.00 to 6.00	12.00 to 8.00
" extra	7.00 to 1.00	8.00 to 6.00	6.00 to 2.00	8.00 to 4.00
" lwr. grds.	1.00 to 10.00	6.00 to 15.00	2.00 to 10.00	4.00 to 15.00
Killarney, Richmond, lncy & spec	10.00 to 2.00	15.00 to 6.00	10.00 to 2.00	15.00 to 4.00
" lower grades	2.00 to 0.00	6.00 to 8.00	2.00 to 10.00	4.00 to 12.00
Chatenay, Wellesley, fan. and spec.	0.00 to 2.00	8.00 to 4.00	10.00 to 2.00	12.00 to 4.00
" lower grades	2.00 to 2.00	4.00 to 8.00	2.00 to 8.00	4.00 to 10.00
Golden Gate, Ivory	2.00 to 1.00	8.00 to 2.00	2.00 to 1.00	10.00 to 6.00
Carnations, Fancy and Novelties	4.00 to 1.00	6.00 to 2.00	4.00 to 1.00	6.00 to 2.00
" Ordinary	1.00 to .30	2.00 to .75	1.00 to .30	2.00 to .60
Violets	.30 to .75	.75 to .30	.30 to .75	.60 to .30
Cattleyas				
Cypripediums	25.00 to 8.00	60.00 to 10.00	25.00 to 8.00	50.00 to 10.00
Lilies	8.00 to 1.00	10.00 to 3.00	12.00 to 1.00	10.00 to 3.00
Lily of the Valley	1.00 to 10.00	3.00 to 25.00	3.00 to 10.00	3.00 to 25.00
Gardenias	10.00 to 2.00	25.00 to 3.00	10.00 to 2.00	25.00 to 3.00
Roman Hy., Paper White Nar.	2.00 to 10.00	3.00 to 25.00	2.00 to 10.00	3.00 to 25.00
Poinsettias	10.00 to 3.00	25.00 to 1.00	10.00 to 3.00	25.00 to 1.00
Slevia	1.00 to 3.00	1.00 to 6.00	1.00 to 3.00	1.00 to 6.00
Mignonette	3.00 to 1.00	6.00 to 1.50	3.00 to 1.00	6.00 to 1.50
Adiantum	1.00 to 8.00	1.50 to 12.00	1.00 to 8.00	1.50 to 12.00
Smilax	8.00 to 25.00	12.00 to 50.00	8.00 to 25.00	12.00 to 50.00
Asparagus Plumosus, strigs.	25.00 to 10.00	50.00 to 15.00	25.00 to 10.00	50.00 to 15.00
" " & Spreo. (100 bchs.)	10.00 to 10.00	15.00 to 15.00	10.00 to 10.00	15.00 to 15.00

B. S. SLINN, Jr.
 WHOLESALE FLORIST
 55 & 57 W. 26th St., New York City
 Tel., 3864 Madison Sq. Shipping Orders Solicited.
VIOLETS Roses and Carnations

TRAENDLY & SCHENCK
WHOLESALE FLORISTS
 Furnish best stock at fair prices all the year round Send for quotations on full orders
 Tel. 798.799 Madison Sq. 44 West 28th Street, New York City

Edward C. Horan
 Wholesale Florist
 55 WEST 28th ST.
 Tel 1462 1463 Madison Square New York

Alexander J. Guttman
THE WHOLESALE FLORIST OF NEW YORK
 43 WEST 28th STREET
 PHONES. 1664-1665 MADISON SQUARE
ENOUGH SAID



HARDY CUT FERNS

Sphagnum Floss, Extra Large Bales, per bale, \$1.25. Fancy and Dagger Ferns our specialty. A trial order will convince you that we ship only first-class stock. Headquarters for Florists' supplies and wire work. All cut flowers in season. **BOXWOOD**, per bunch 35c, 50 lbs. \$7.50.

MICHIGAN CUT FLOWER EXCHANGE, INC., All 'phone connections 38-40 Broadway, Detroit, Mich.

WHOLESALE FLORISTS
54 West 28th St.
NEW YORK
Telephone 3559 Madison Sq.

A. L. YOUNG & CO.

RECEIVERS & SHIPPERS OF CUT FLOWERS.
CONSIGNMENTS SOLICITED.

Headquarters in Western New York
FOR
ROSES, CARNATIONS
And all kinds of Seasonable Flowers
Wm. F. Kasting Co.
Wholesale Commission Florist, also Dealer in
Florists' Supplies and Wire Designs.
383-87 ELLICOTT ST.
BUFFALO, N. Y.
Give us a trial. We can please you.

FRANK S. HICKS & CO.
Wholesale Florists.
Open Now for Consignments of Cut Flowers.
52 West 28th Street, - New York City
Tel. 2920 Mad. Sq.

FRANK MILLANG
Wholesale Florist
Telegraphic Orders Filled and Delivered.
55-57 West 26th St., New York City.

Charles Millang
50 West 29th St., New York City
Cut Flowers on Commission
A Reliable Place to Consign to or order from
Telephone: 3860-3871 Madison Square

A. MOLTZ
Will purchase flowers on order in N. Y. market and ship carefully at prevailing wholesale prices. Address
55-57 West 26th Street, New York City

Best Flowers
IN THE
BOSTON MARKET
N. F. McCarthy & Co.
84 Hawley St., BOSTON, MASS.
Send for Prices

HENRY M. ROBINSON & CO.
WHOLESALE COMMISSION FLORISTS
Finest Grades of Roses, Carnations, Chrysanthemums, Lily of the Valley, Violets, etc.
15 Province St. & 9 Chapman Pl., Boston, Mass.
See our Fern ad.

WHOLESALE FLOWER MARKETS. — PER 100. — TO DEALERS ONLY.

	CINCINNATI Dec. 31	DETROIT Jan. 5	BUFFALO Jan. 6	PITTSBURG Jan. 6
ROSES				
Am. Beauty, Fan, and Sp.	50.00 to 75.00	25.00 to 25.00	75.00 to 85.00	50.00 to 65.00
“ Extra	40.00 to 50.00	15.00 to 20.00	35.00 to 50.00	30.00 to 40.00
“ No. 1	20.00 to 30.00	10.00 to 15.00	20.00 to 30.00	10.00 to 20.00
“ Lower grades	10.00 to 15.00	6.00 to 10.00	10.00 to 20.00	6.00 to 10.00
Bride, Maid, F. & S.	10.00 to 12.00	8.00 to 10.00	10.00 to 15.00	10.00 to 15.00
“ Extra	8.00 to 10.00	4.00 to 6.00	8.00 to 10.00	8.00 to 12.00
“ Low gr.	6.00 to 8.00	8.00 to 10.00
Killarney, Richmond, Fan, & Sp.	10.00 to 12.00	8.00 to 10.00	8.00 to 10.00	10.00 to 15.00
“ Lower grades	6.00 to 8.00	4.00 to 6.00	4.00 to 6.00	6.00 to 12.00
Chatenay, Wellesley, Fan & Sp.	10.00 to 12.00	8.00 to 10.00	8.00 to 10.00	10.00 to 15.00
“ Lower grades	6.00 to 8.00	4.00 to 6.00	4.00 to 6.00	6.00 to 10.00
Golden Gate, Ivory	8.00 to 10.00	8.00 to 10.00	8.00 to 10.00	6.00 to 10.00
CARNATIONS				
Fancy and Novelties	6.00 to 8.00	3.00 to 5.00	5.00 to 7.00	4.00 to 6.00
Ordinary	3.00 to 4.00	2.00 to 3.00	2.00 to 3.00
MISCELLANEOUS				
Violets	1.00 to 1.50	1.00 to 1.50	.75 to 1.25	.75 to 1.25
Catleyas	34.00 to 50.00	75.00 to 100.00
Cypripediums	8.00 to 12.00	20.00 to 25.00
Lilies	15.00 to 15.00	4.00 to 15.00	15.00 to 20.00
Lily of the Valley	4.00 to 5.00	3.00 to 5.00	3.00 to 5.00
Roman Hy., Paper White Nar.	3.00 to 4.00	3.00 to 4.00	2.00 to 3.00	2.00 to 3.00
Poinsettia	20.00 to 30.00	15.00 to 40.00	15.00 to 30.00
Stevia	1.00 to 1.50	2.00 to 2.00	1.00 to 1.25	2.00 to 3.00
Mignonette	3.00 to 6.00	0.00 to 0.00	3.00 to 6.00	4.00 to 6.00
Adiantum	1.50 to 2.50	.50 to 1.50	1.00 to 1.25
Whitmann Foods
Senilax	15.00 to 15.00	15.00 to 15.00
Asparagus Plumosus, strigosa	40.00 to 50.00	5.00 to 50.00	45.00 to 60.00	30.00 to 50.00
“ “ & Sprea (100 bchs.)	25.00 to 35.00	30.00 to 40.00	35.00 to 50.00	40.00 to 75.00

SAMUEL A. WOODROW
WHOLESALE PLANTSMAN
Palms, Large and Small Ferns, etc.
53 West 30th Street, NEW YORK
Telephone 2083 Madison

WILLIAM H. KUEBLER
Brooklyn's Foremost and Best
WHOLESALE COMMISSION HOUSE
A First Class Market for all CUT FLOWERS
28 Willoughby St., Brooklyn, N. Y.
Tel. 4591 Main

CLEARY'S HORTICULTURAL CO.
Management AMBEROSE T. CLEARY
Wholesale Contracting, Jobbing, Auction
HORTICULTURAL PRODUCTS
of every description.
Consignments Received. Surplus Stock Converted.
62 Vesey St., NEW YORK

Moore, Hentz & Nash,
Wholesale Commission Florists,
55 and 57 West 26th Street,
Telephone No. 756
Madison Square. **New York.**

H. C. BERNING
Wholesale Florist
1402 Pine Street, ST. LOUIS, MO.

Alex Mann, Jr. Co. Inc.
Wholesale Dealer in
Florists' Supplies and Cut Flowers
White Doves, \$9.00 per doz.
Galax Leaves.
1125 Polk Street, San Francisco, Cal.

J. B. Murdoch & Co.
Wholesale Florists
FLORISTS' SUPPLIES
545 Liberty St., PITTSBURG, PA.
Long Distance Phone 1435 Court.

REED & KELLER
122 West 25th St., New York
Florists' Supplies
We manufacture all our
Metal Designs, Baskets, Wire Work & Novelties
and are dealers in
Glassware Decorative Greens and Florists' Requisites.

Buyer's Directory and Ready Reference Guide

Advertisements under this head, one cent a word. Initials count as words.

Regular advertisers in this issue are also listed under this classification without charge. Reference to List of Advertisers will indicate the respective pages.

Buyers failing to find what they want in this list will confer a favor by writing us and we will try to put them in communication with reliable dealers.

ACCOUNTANT

R. J. Dysart, 28 State St., Boston.
For page see List of Advertisers.

ARAUCARIAS

Godfrey Aschmann, 1012 Ontario St., Philadelphia, Pa.
For page see List of Advertisers.

ARTIFICIAL CALYX

Maxfield & Dimond, Warren, R. I.

ASPARAGUS

Asparagus Sprengeri, field grown, \$4.00 and \$6.00 per 100. C. Winterlich, Defiance, Ohio.

Asparagus Plumosa, 2 in. pots. Fine plants. \$2.50 per 100; \$20.00 per 1000. Cash with order or good reference. Erie Floral Co., Erie, Pa.; or, Wm. F. Kasting Co., 385 Ellcott St., Buffalo, N. Y.

AUCTION SALES

Cleary's Horticultural Co., 62 Vesey St., New York.
Horticultural Products of Every Description.
For page see List of Advertisers.

Sales every Tuesday and Friday. If you cannot attend send bids and shipping instructions. Catalogues on application. N. F. McCarthy & Co., 84 Hawley St., Boston.

AZALEAS

A. Leuthy & Co., Perkins St. Nurseries, Roslindale, Mass.
For page see List of Advertisers.

W. W. Edgar Co., Waverley, Mass.
For page see List of Advertisers.

Bay State Nurseries, N. Abington, Mass.
For page see List of Advertisers.

Bobblin & Atkins, Rutherford, N. J.

BAMBOO CANES

Stump & Walter Co., 50 Barclay St., New York.
For page see List of Advertisers.

Yokohama Nursery Co., 31 Barclay Street, New York.
For page see List of Advertisers.

BAY TREES.

Specimens and pairs, all sizes. Send for prices. N. F. McCarthy & Co., 84 Hawley St., Boston.

Bay Trees and Box Trees, standards and pyramids. All sizes. Price list on application. J. Roehrs Co., Rutherford, N. J.

BOILERS

BOILERS. "Burnham" Boilers made for greenhouse heating. Lord & Burnham, 1133 Broadway, N. Y.

BOXWOOD

A. Leuthy & Co., Perkins St. Nurseries, Roslindale, Mass.
For page see List of Advertisers.

Henry M. Robinson & Co., 15 Province St., Boston.
For page see List of Advertisers.

BUILDING MATERIAL

BUILDING MATERIAL of all description for All Cypress, Seal-Iron, Iron Frame or Truss Houses. Hot Red Sash and Frames. Lord & Burnham Co., 1133 Broadway, N. Y.

BULBS AND TUBERS

Joseph Breck & Sons, 47-54 N. Market St., Boston.
For page see List of Advertisers.

J. M. Thornburn & Co., 33 Barclay St., New York.
For page see List of Advertisers.

A. T. Boddington, 342 W. 14th St., N. Y.
For page see List of Advertisers.

Rickards Bros., 37 East 19th St., New York.
For page see List of Advertisers.

H. F. Michell Co., Philadelphia.
For page see List of Advertisers.

H. E. Fiske Seed Co., Faneuil Hall Sq., Boston.
For page see List of Advertisers.

James Vick's Sons, Rochester, N. Y. Fall Bulbs.
For page see List of Advertisers.

D. Rusconi, 128 W. Sixth St., Cincinnati, O. Liliun Auratum, Roseum, Multiflorum.
For page see List of Advertisers.

Aug. Rolker & Sons, 31 Barclay St., New York.
Seasonable Import Plants and Bulbs.
For page see List of Advertisers.

John Scheepers & Co., 4 and 6 Old Slip, New York.
Lily of the Valley Excellenta.
For page see List of Advertisers.

K. Velthuis, Hillegom, Holland, Represented by Felix Bosch, 260 Clarendon St., Boston.
Bulbs French and Dutch.
For page see List of Advertisers.

CARNATIONS

Field Grown

The H. Weber & Sons Co., Oakland, Md. Seedling Carnation Toreador.
For page see List of Advertisers.

Rooted Cuttings

John E. Halnea, Bethlehem, Pa.
For page see List of Advertisers.

F. Dorner & Sons Co., Lafayette, Ind.
For page see List of Advertisers.

S. S. Skidelsky, 1741 N. 18th St., Philadelphia.
For page see List of Advertisers.

Frank H. Kimberly, 631 Townsend Ave., New Haven, Ct.

Chicago Carnation Co., Joliet, Ill.
For page see List of Advertisers.

F. R. Pierson Co., Tarrytown, N. Y. Windsor and White Enchantress Rooted Cuttings.
For page see List of Advertisers.

Jacob Schulz, 644 4th Av., Louisville, Ky. White Enchantress Rooted Cuttings.
For page see List of Advertisers.

CHRYSANTHEMUMS

Charles H. Potty, Madison, N. J.
For page see List of Advertisers.

W. W. Edgar Co., Waverley, Mass.
For page see List of Advertisers.

CINERARIAS

John J. Coonan, Haverstraw, N. Y.

CONIFERS

John Waterer & Sons, Ltd., American Nursery, Bagshot, Eng.
For page see List of Advertisers.

Bay State Nurseries, North Abington, Mass.
For page see List of Advertisers.

Write for prices on all choice ornamental conifers. N. F. McCarthy & Co., 84 Hawley St., Boston, Mass.

CUT FLOWER BOXES.

Edwards Folding Box Co., Philadelphia.
For page see List of Advertisers.

Getmore Box Factory, Inc., Belleville, Ala. Light Wood Boxes.
For page see List of Advertisers.

We Have Them.

Send for New Illustrated Catalogue. H. Bayersdorfer & Co., 1129 Arch St., Philadelphia, Pa.

Folding cut flower boxes, the best made. Write for list. Holton & Hunkel Co., Milwaukee, Wis.

CYCLAMEN.

Thomas Roland, Nahant, Mass.

DAHLIAS

David Herbert & Son, Atco, N. J.
For page see List of Advertisers.

J. L. Moore, Northboro, Mass.
For page see List of Advertisers.

A. B. Davis & Son, Purcellville, Va.

DECORATIVE PLANTS

A. Leuthy & Co., Roslindale, Mass.
For page see List of Advertisers.

Jullus Roehrs, Rutherford, N. J.
For page see List of Advertisers.

Anton Schulthels, College Point, N. Y.
For page see List of Advertisers.

FERNS

A. Leuthy & Co., Roslindale, Mass.
For page see List of Advertisers.

H. H. Barrows & Son, Whitman, Mass. Nephrolepis Whitman.
For page see List of Advertisers.

Godfrey Aschmann, 1012 Ontario St., Philadelphia, Pa.
For page see List of Advertisers.

John Scott, Brooklyn, N. Y.
For page see List of Advertisers.

FERTILIZERS

Palverized Manure Co., 31 Union Stock Yards, Chicago, Ill.
Wizard Brand Cattle Manure.
For page see List of Advertisers.

Thos. J. Grey & Co., 32 and 33 South Market St., Boston. High-Grade Scotch Soot.
For page see List of Advertisers.

FLORISTS' GREENING PINS

We Have Them. Send for New Illustrated Catalogue. H. Bayersdorfer & Co., 1129 Arch St., Philadelphia, Pa.

FLORAL PHOTOGRAPHS

Floral Photographs. Foley's 226-228 1-2 Bowery, New York.

For List of Advertisers See Page 52

INSECTICIDES.

- Andrew Wilson, Summit, N. J. Dept. 8.
Plant Oil.
For page see List of Advertisers.
- Carman's Anti-pest.
Perfection Chemical Co., Flushing, N. Y.
W. W. Rawson & Co., 5 Union St., Boston.
For page see List of Advertisers.
- Nicotinide kills all greenhouse pests
P. R. Palethorpe Co.,
Eleventh St., Owensboro, Ky.
For page see List of Advertisers.
- Nicotine Mfg. Co., St. Louis, Mo.
Nikoteen.

JAPANA CUT FLOWER HOLDER

- M. V. Garosey, 130 So. Walola Av., La
Grange, Ill. Dept. J.
For page see List of Advertisers.
- We Have Them.
Send for New Illustrated Catalogue.
H. Bayersdorfer & Co.,
1129 Arch St., Philadelphia, Pa.

KENTIAS

- A. Leuthy & Co., Roslindale, Mass.
For page see List of Advertisers.
- Godfrey Aschmann, 1012 W. Ontario St.,
Philadelphia.
For page see List of Advertisers.

LEADING RETAIL FLORISTS

- Park Floral Co., Denver, Colo.
For page see List of Advertisers.
- George H. Cooke, Washington, D. C.
For page see List of Advertisers.
- Gude Bros. Co., 1214 F St.,
Washington, D. C.
For page see List of Advertisers
- Atlanta Floral Co., Atlanta, Ga.
For page see List of Advertisers.
- F. J. Hauswirth, 232 Michigan Ave.,
Chicago.
For page see List of Advertisers.
- William J. Smyth, Michigan Ave. and 31st
St., Chicago.
For page see List of Advertisers
- Jacob Schulz, 644 4th Ave., Louisville, Ky.
For page see List of Advertisers

- Thos. F. Galvin, 124 Tremont St., Boston.
For page see List of Advertisers.
- Jullus A. Zinn, 2 Beacon St., Boston.
For page see List of Advertisers.

- Houghton & Clark, 396 Boylston St.,
Boston.
For page see List of Advertisers.

- Sidney Hoffman, 59-61 Massachusetts Ave.,
Boston.
For page see List of Advertisers.

- J. Breitmeyer's Sons, Detroit, Mich.
For page see List of Advertisers.

- Samuel Murray, 1017 Broadway,
Kansas City, Mo.
For page see List of Advertisers.

- Wm. L. Rock Flower Co., 1116 Walnut
St., Kansas City, Mo.
For page see List of Advertisers.

- Fred C. Weber, 4326 Olive St., St. Louis,
Mo.
For page see List of Advertisers.

- H. G. Eyres, 11 N. Pearl St., Albany, N. Y.
For page see List of Advertisers.

- David Clarke's Sons, 2139-2141 Broadway,
New York.
For page see List of Advertisers.

- W. H. Donohoe, 17 E. 28th St., New York.
For page see List of Advertisers.

- Alex. McConnell, New York.
For page see List of Advertisers.

- A. Warendorff, 1193 Broadway, New York.
For page see List of Advertisers.

- Robert G. Wilson, Fulton St. and Greene
Ave., Brooklyn, N. Y.
For page see List of Advertisers.

- Thomas Young, Jr., New York.
For page see List of Advertisers
- Young & Nugent, 42 W. 28th St., N. Y.
For page see List of Advertisers
- Mills the Florist, Jacksonville, Fla.
Telegraph or mail orders promptly filled.
Long distance telephone connections.

NEW AND RARE PLANTS

- Rose Hill Nurseries, New Rochelle, N. Y.
For page see List of Advertisers.

NICO-FUME

- Kentucky Tobacco Product Co.,
Louisville, Ky.

NURSERY STOCK

- John Waterer & Sons, Ltd.,
American Nursery, Bagshot, England.
For page see List of Advertisers.
- New England Nurseries, Bedford, Mass.
Shrubs, Roses and Herbaceous Perennials.
Specimen Pyramidal Box.
For page see List of Advertisers.

- The Conard & Jones Co., West Grove, Pa.
Hardy Stock.
For page see List of Advertisers.

- Bay State Nurseries, N. Abington, Mass.
Herbaceous Perennials, Hardy Ornamental
Trees.
For page see List of Advertisers.

- Cleary's Horticultural Co., 62 Vesey St.,
New York.
For page see List of Advertisers.

- P. Ouwerkerk, 216 Jane St., Weehawken
Height, N. J.
Hollad Nursery Stock for Forcing.
For page see List of Advertisers

- Nursery Stock, N. F. McCarthy & Co.,
84 Hawley St., Boston, Mass.

ORCHID PLANTS

- Lager & Hurrell, Summit, N. J.
For page see List of Advertisers.
- Sander, St. Albans, England.
Importers, Exporters, Growers, Hybridists
For page see List of Advertisers.

- Jullus Roehrs Co., Rutherford, N. J.
For page see List of Advertisers.

- Carrillo & Baldwin, Secaucus, N. J.
For page see List of Advertisers.

- Joa. A. Maada, 191 Valley Road, W.
Orange, N. J.
For page see List of Advertisers.

- Ordenez Bros., Madison, N. J., Box 106.
For page see List of Advertisers.

PALMS

- A. Leuthy & Co., Perkins St. Nurseries,
Roslindale, Mass.
For page see List of Advertisers.

- Kentia, Phoenix, etc., all sizes. Write
for new price list. Jullus Roehra Co.,
Rutherford, N. J.

PAINT AND PUTTY

- PAINT AND PUTTY: Ideal Greenhouse
lead; Special Greenhouse Putty. Lord &
Burnham, 1133 Broadway, N. Y.

PANSY PLANTS.

- Choice pansy plants, 50c. per 100; \$4.00
per 1000. Cash. Aug. Zirngelbel, Need-
ham, Mass.

PATENTS

- Siggers & Siggers, Washington, D. C.
For page see List of Advertisers.

PEAT

- Orchid peat, Rotted peat, Azalea peat,
Leaf-Mould, Live Sphagnum moss, Baled
Sphagnum moss, Green Clump moss, etc.
Jobbers' list on application. C. W. Brown-
ell & Co., Walden, N. Y.

PIPE AND FITTINGS

- Foley Mfg. Co., between Western Ave. and
26th St., Chicago, Ill.

- PIPE AND FITTINGS. Cast Iron and
Wrought Pipe, Valves, Elbows, Pipe Hooks,
Automatic Air Headers, etc. Lord &
Burnham, 1133 Broadway, N. Y.

PLANT BED CLOTH

- Mineralized Rubber Co., 18 Cliff St., N. Y.
For page see List of Advertisers.

POT HANGERS

- Pot nangers, Kramer's \$1 doz. by exp.,
\$1.25 by mail. J. N. Kramer & Son, Cedar
Rapids, Ia.

PRUNING SHEARS

- Rhodes Mfg. Co., Grand Rapids, Mich.
Dept. R.

PYRIMIDAL BOX

- Bay State Nurseries, N. Abington, Mass.
For page see List of Advertisers.

RAFFIA

- We Have It.
Send for New Illustrated Catalogue.
H. Bayersdorfer & Co.,
1129 Arch St., Philadelphia, Pa.
- Raffia (colored), 20 beautiful shades
Samples free. R. M. Conroy Co., Camden,
N. J.; 810 Washburn Ave., Chicago, Ill.

RHODODENDRONS

- John Waterer & Sons, Ltd.,
American Nursery, Bagshot, England.
For page see List of Advertisers.

ROSES

- Jullus Roehra Co., Rutherford, N. J.
Rambler Rose, Newport Falry.
For page see List of Advertisers.
- New England Nurseries, Inc., Bedford,
Mass.
Roses for Forcing.
For page see List of Advertisers.
- Bay State Nurseries, N. Abington, Mass.
For page see List of Advertisers.

- A. N. Pierson, Cromwell, Conn.
Grafted and Own Root Roses.
For page see List of Advertisers.

- Bobbink & Atkins, Rutherford, N. J.

- Thomas Roland, Nahant, Mass.
Lady Gay Roses.

- 400 varieties; own roots; summer grown.
Leedle Company, Springfield, Ohio.

- Low-budded roses, No. 1, \$95.00; No.
11-2, \$65.00 1000. H. T. Jones, Elizabeth,
N. J.

- Crimson Ramblers, extra strong, 3-yr.,
for forcing, at 9 cts. Gilbert Costich,
Rochester, N. Y.

SCALECIDE

- B. G. Pratt Co., 11 Broadway, New York.
For page see List of Advertisers.

SEEDS

- T. J. Grey Co., 32 So. Market St.,
Boston, Mass.
For page see List of Advertisers.

- Joseph Breck & Sons,
51 and 52 N. Market St., Boston, Mass.
For page see List of Advertisers.

- W. Atlee Burpee & Co., Philadelphia.
For page see List of Advertisers.

- J. M. Thorburn & Co., 33 Barclay St., N. Y.
For page see List of Advertisers.

- A. T. Boddington, 342 W. 14th St., N. Y.
Vinca Seed.
For page see List of Advertisers.

- H. F. Michell Co., 1017 Market St., Phila.
For page see List of Advertisers.

- James Vlek's Sons, Rochester, N. Y.
Vlek's Superb Pansy Seed.
For page see List of Advertisers.

- Hjalmar Hartmann & Co.,
12 Stormgade, Copenhagen, Denmark.
Cantiflower and Cabbage Seed.
For page see List of Advertisers.

- Rickards Bros., 37 E. 19 th St., New York.
For page see List of Advertisers.

- R. & J. Farquhar & Co., 6-7 So. Market
St., Boston.
Giant Cyclamen Seed.
For page see List of Advertisers.

For List of Advertisers See Page 52

SEEDS—Continued

- C. C. Morse & Co., 48-56 Jackson St., San Francisco, Cal.
For page see List of Advertisers.
- H. E. Fiske Seed Co., Faneuil Hall Sq., Boston.
For page see List of Advertisers.
- Braslan Seed Growers Co., San Jose, Cal.
For page see List of Advertisers.
- O. V. Zangen, Hoboken, N. J.
For page see List of Advertisers.
- R. Wibolff, Nakskov, Denmark.
Snowball Cauliflower Seed.
For page see List of Advertisers.
- Sander & Son, Bruges, Belgium.
Cocos Weddelliana Seed.
For page see List of Advertisers.
- W. E. Marshall & Co., 146 W. 23d St., New York.
- Crego aster seed. Ask for circular. G. S. Crego, Maywood, Ill.

SMILAX

- E. A. Beaven, Evergreen, Ala.
Southern Wild Smilax; Log Mossea.
For page see List of Advertisers.

SPHAGNUM MOSS

- Live Sphagnum moss, orchid peat and orchid baskets always on hand. Lager & Hurrell, Summit, N. I.

We Have It.

- Send for New Illustrated Catalogue.
H. Bayersdorfer & Co.,
1129 Arch St., Philadelphia, Pa.

STEAM TRAP

- E. Hippard, Youngstown, O.

VEGETABLE PLANTS

- 10,000 Tomato plants. Genuine Comet and Lorillard Forcing. Good, strong plants. \$2.00 per 100. Also cuttings from 20 varieties of carnations, good stock. Locust St. Greenhouses, J. H. A. Hutchison, Prop., Oxford, Pa.

VENTILATING APPARATUS

- Pierson U-Bar Co., 1 Madison Sq., N. Y.
For page see List of Advertisers.

- Hitchings & Co., 1170 Broadway, N. Y.
For page see List of Advertisers.

- Foley Mfg. Co., between Western Ave. and 26th St., Chicago, Ill.
For page see List of Advertisers.

- John A. Payne, 260-274 Culver Ave., Jersey City, N. J.
For page see List of Advertisers.

- VENTILATING MACHINERY**, New Model encased, self-oiling gear; Standard Model Open Gear. Lord & Burnham, 1183 Broadway, N. Y.

WAGON HEATER

- Lehman Bros., 10 Bond St., New York.
For page see List of Advertisers.

WIREWORK

- Reed & Keller, 122 W. 25th St., N. Y.
For page see List of Advertisers.
- Wirework. Write for our catalogue. Holton & Hunkel Co., Milwaukee, Wis.
- William E. Heitscher's Wire Works, 38-40 Broadway, Detroit, Mich.

- The "Just Right" kind. Send for price list. Frank W. Ball, 31 East Third Street, Cincinnati, O.

We Have Them.

- Send for New Illustrated Catalogue.
H. Bayersdorfer & Co.,
1129 Arch St., Philadelphia, Pa.

**WHOLESALE FLORISTS—
Boston**

- N. F. McCarthy & Co., 84 Hawley St., Boston.
For page see List of Advertisers.
- H. M. Robinson & Co., 15 Province St. and 9 Chapman Pl., Boston.
For page see List of Advertisers.
- Welch Bros., 226 Devonshire St., Boston.
For page see List of Advertisers.

WHOLESALE FLORISTS—

Continued

Buffalo

- Wm. F. Kasting Co., 383-87 Ellcott St., Buffalo, N. Y.
For page see List of Advertisers.

Chicago

- Chas. W. McKellar, 51 Wabash Ave., Chicago.
For page see List of Advertisers.
- Peter Reinberg, 51 Wabash Ave., Chicago.
For page see List of Advertisers.

- E. F. Winterson Co., 45-49 Wabash Ave., Chicago.
For page see List of Advertisers.

Detroit

- Michigan Cut Flower Exchange, 38 and 40 Broadway, Detroit, Mich.
For page see List of Advertisers.

New York

- J. K. Allen, 106 W. 28th St., New York.
For page see List of Advertisers.

- J. S. Fenrich, 110 W. 28th St., New York.
For page see List of Advertisers.

- Ford Bros., 48 W. 28th St., New York.
For page see List of Advertisers.

- H. E. Froment, 57 W. 28th St., New York.
For page see List of Advertisers.

- Alex. J. Guttman, 43 W. 28th St., New York.
For page see List of Advertisers.

- E. C. Horan, 55 W. 28th St., New York.
For page see List of Advertisers.

- A. H. Langjahr, 55 W. 28th St., New York.
For page see List of Advertisers.

- James McManus, 42 W. 28th St., New York.
For page see List of Advertisers.

- Chas. Millang, 50 W. 29th St., New York.
For page see List of Advertisers.

- John J. Raynor, 49 W. 28th St., New York.
For page see List of Advertisers.

- W. F. Sheridan, 39 W. 28th St., New York.
For page see List of Advertisers.

- Traendly & Schenck, 44 W. 28th St., New York.
For page see List of Advertisers.

- John Young, 51 W. 28th St., New York.
For page see List of Advertisers.

- Moore, Hentz & Nash, 55 and 57 W. 26th St., New York.
For page see List of Advertisers.

- Frank S. Hicks & Co., 52 W. 28th St., New York.
For page see List of Advertisers.

- Frank Millang, 57 W. 26th St., New York.
For page see List of Advertisers.

- Wm. H. Kuebler, 28 Willoughby St., Brooklyn, N. Y.
For page see List of Advertisers.

- Phillip F. Kessler, 55 and 57 W. 26th St., New York.
For page see List of Advertisers.

- A. Moltz, 55-57 W. 26th St., New York.
For page see List of Advertisers.

- B. S. Sinn, Jr., 55 W. 26th St., New York.
For page see List of Advertisers.

- A. L. Young & Co., 54 W. 28th St., New York.
For page see List of Advertisers.

WHOLESALE FLORISTS—

Continued

Philadelphia

- W. E. McKissick, 1221 Filbert St., Philadelphia, Pa.
For page see List of Advertisers.

- Leo Niessen Co., 1209 Arch St., Philadelphia, Pa.
For page see List of Advertisers.

- The S. S. Pennock-Meehan Co., 1608-16 Ludlow St., Philadelphia, Pa.
For page see List of Advertisers.

- Edward Reid, 1526 Ranstead St., Philadelphia, Pa.
For page see List of Advertisers.

- A. M. Campbell, 1510 Sansom St., Philadelphia.
For page see List of Advertisers.

- Wm. J. Baker, South Penn. Square, Philadelphia, Pa.

Pittsburg

- J. B. Murdoch & Co., 545 Liberty St., Pittsburg, Pa.
For page see List of Advertisers.

San Francisco

- Alex. Mann, Jr., Co., 1125 Polk St., San Francisco, Cal.
For page see List of Advertisers.

St. Louis

- H. G. Berning, 1402 Pine St., St. Louis, Mo.
For page see List of Advertisers.

WHOLESALE PLANTSMAN

- Samuel A. Woodrow, 53 W. 30th St., New York.
For page see List of Advertisers.

New Offers in This Issue.

CANNAS.

- The Conard & Jones Co., West Grove, Pa.
For page see List of Advertisers.

CARNATION LLOYD.

- H. A. Jahn, New Bedford, Mass.
For page see List of Advertisers.

CARNATION TOREADOR DISSEMINATION POSTPONED.

- H. Weber & Sons Co., Oakland, Md.
For page see List of Advertisers.

GALAX.

- W. M. Woodruff & Son, Lowgap, N. C.
For page see List of Advertisers.

GERANIUM ALLIANCE: IVY AND CACTUS GERANIUMS.

- R. Vincent, Jr. & Sons Co., White Marsh, Maryland.
For page see List of Advertisers.

GLADIOLUS PRIMULINUS.

- J. M. Thorburn & Co., 33 Barclay St., New York.
For page see List of Advertisers.

HARDY ROSES.

- Ellwanger & Barry, Rochester, N. Y.
For page see List of Advertisers.

VIOLET BOSTON.

- William Sim, Cliftondale, Mass.
For page see List of Advertisers.

WANTED: UNROOTED CUTTINGS.

- Clarence Welch Bros., 226 Devonshire St., Boston.
For page see List of Advertisers.

In writing to Advertisers kindly mention Horticulture

List of Advertisers

Page	Page
Allen J. K. 46	McManus Jas. 46
American Nursery... 31	Michell H. F. Co. ... 40
Aschmann Godfrey... 30	Michigan Cut Flower Exchange... 47
Atlanta Floral Co. ... 43	Millang Charles... 47
Barrows H. H. & Son... 31	Mineralized Rubber Co. 55
Baur Floral Co. 32	Moltz, A. 47
Bayersdorfer H. & Co. 44	Moninger J. C. 55
Bay State Nurseries... 30	Monre, Hentz & Nash 47
Beaven E. A. 42	Moore, J. L. 31
Berning H. G. 47	Morse C. C. & Co. ... 41
Boddington A. T. 41	Murdoch J. B. & Co. 47
Boston Florist Letter Co. 42	Murray Samuel ... 43
Boston Plate and Window Glass Co. ... 55	New England Nurseries ... 31
Bosch, Felix... 49	Niessen Leo. Co. ... 32
Braslan Seed Growers Co. 47	Ordenez Bros. 39
Breck Joseph & Sons 41	Ouwerkerk P. 31
Breitmeyer's J. Sons 43	Ordonez Bros. 39
Bridgeman's Seed Warehouse... 41	Ouwerkerk P. 31
Burpee W. A. & Co. 41	Palethorpe P. R. Co. 54
Carrillo & Baldwin ... 39	Park Floral Co. 43
Cassidy I. 55	Payne John A. 54
C. F. 32	Pennock-Meehan Co. 44
Chicago Carnation Co. 32	Perfection Chemical Co. 54
Clarke's David, Sons 43	Perkins St. Nurseries 30
Cleary's Horticultural Co. 47	Pierson A. N. 31
Conard & Jones Co. ... 31	Pierson F. R. Co. ... 32
Cooke G. H. 43	Pierson U Bar Co. ... 56
Cowee A. 40	Pratt B. G. Co. 53
Donohoe W. H. 43	Pulverized Manure Co. 54
Dorner F. Sons & Co. 32	Rawson W. W. & Co. 54
Dreer H. A. 31-55	Raynor John L. ... 46
Dysart R. J. 44	Reed & Keller... 47
Edgar, W. W. Co. 45	Reid Edw. 44
Edwards Folding Box Co. 44	Reinberg Peter... 44
Elliott Wm. & Sons. 41	Rickards Bros. 41
Ellwanger & Barry ... 31	Robinson H. M. & Co. 42-47
Eringer, J. W. 55	Rock Wm. L. Flo. Co. 43
Estler I. G. 55	Roehrs Julius Co. ... 31-30
Ernest W. H. 55	Rolker August & Sons 30-55
Eyres 43	Rose Hill Nurseries... 31
Farquhar R. & J. & Co. 41	Rusconi D. ... 30
Fenrich J. S. 46	Sander & Son 30-39
Fiske, H. E. Seed Co. 41	Scheepers John & Co. 30
Foley Mfg. Co. 55	Schultheis Anton ... 30
Ford Bros. 40	Schulz Jacob... 32-43
Froment H. E. 46	Scott, John. 31
Galvin Thos. F. 43	Sheridan W. F. 40
Garnsey M. V. 42	Siggers & Siggers... 55
Getmore Box Factory 42	Sim, Wm. 30
Grey T. J. Co. 41	Situations & Wants... 52
Gude Bros. Co. 43	Skidelsky S. S. 32
Guttman Alex. J. 46	Slinn B. S. Jr. 46
Hall Asso. 55	Smyth Wm. J. 43
Haines, J. E. 32	Standard Plate Glass Co. 55
Hartmann Hjalmar & Co. 41	Stearns A. T. Lumber Co. 55
Hauswirth P. J. 43	Stump & Walter Co. 40-41
Herbert David & Son. 31	Thorburn J. M. & Co. 41
Hews A. H. & Co. 55	Totty Chas. H. 32
Hicks Frank S. & Co. 47	Traendly & Schenck. 46
Hilfinger Bros. 55	Valentine, J. A. 43
Hitchings & Co. 56	Yelhuys, K. 40
Hoffman 43	Vick's Jas. Sons ... 41
Huran E. C. 46	Vincent R. Jr. & Sons. 40
Houghton & Clark... 43	Warendorff A. 43
Jahn, H. A. 32	Waterer John & Sons. 31
Jacobs S. & Sons 55	Weber F. C. 43
Kasting W. F. 37	Weber H. & Sons... 32
Kervan Co., The. 42	Welch Bros. 44
Kessler, P. F. 46	Wibolt, R. 41
King Cons. Co. 55	Wilson. 43
Koral Mfg. Co. 42	Wilson, Andrew... 34
Kuebler Wm. H. 47	Winterson, E. F. Co. 44
Lager & Hurrell ... 39	Woodrow, Sam'l A. ... 47
Langjahr, Alfred H. 46	Woodruff, W. M. & Son. 42
Lehman Bros. 55	Yokohama Nursery Co. 37
Leuthy A. & Co. 30	Young A. L. 47
Lord & Burnham Co. 56	Young John 46
Manda Jos. A. 9	Young, Thos. Jr. ... 43
Mann, Alex. Jr. Co. ... 47	Young & Nugent... 43
McCarthy N. F. & Co. 47	Zangen O. V. 41
McConnell Alex. ... 43	Zinn, J. A. 43
McKellar Charles W. 41	
McKissick, W. E. 44	

A PROFITABLE ASTER.



A new industry for the fruit grower and poultryman and small farmer as well, is the aster culture, especially that of the new improved variety recently developed and introduced by The Scientific Special Crops Intense Culture Ranch of Elmhurst, Ill. Mr. E. A. Kibbe, the originator, gives the following interesting information regarding this aster which appears in the accompanying illustration.

"This improved aster is of the chrysanthemum type, being unlike all other varieties of asters heretofore produced. It is of the Burbank strain; its name is the Lady Roosevelt. The flowers are of unusual size, 4 1-2 and 4 3-4 in. in diameter, borne on stems of a very stiff, wiry nature 36 in. in length. They were sold this past season at wholesale at \$1.00 per doz. net, bringing more than double the price an aster was ever before marketed at, thus enabling the grower to realize at the rate of \$8000 per acre and over. As aster blooms can be shipped 2000 miles without deterioration, and can be grown as successfully by an amateur as an experienced gardener, no greenhouse or hotbed required, it is a very commendable crop to cultivate."

The company issues an illustrated folder for free distribution.

WANTS, FOR SALE, ETC.

Advertisements in this column one cent a word. Initials count as words. Cash with order. All correspondence addressed "care HORTICULTURE" should be sent to 11 Hamilton Place, Boston.

SITUATIONS WANTED

WANTED—Position with reliable wholesale or retail seed house as seedsman; six years' experience with trustworthy seed firms; nationality, Scotch. Address Seeds, care Horticulture.

SITUATION WANTED in general greenhouse work; single, age 35, five years' experience, commercial. Address W. W., care HORTICULTURE.

FOR SALE

FOR SALE—A large consignment of 16x24 double thick American glass, A and B quality. For further information write Parshelsky Brothers, 59 Montrose Avenue, Brooklyn, N. Y.

FOR SALE—Greenhouses 5,000 feet, heavily stocked, nearly new, flourishing trade. A bargain, \$1,000. Reason for selling, other business. Knoll Floral Co., Piercetou, Ind.

FOR SALE—2000 feet second-hand 4 inch cast iron pipe with fittings. In perfect condition. Apply to T., care Horticulture Pub. Co.

GOOD RESULTS OF INSPECTION LAWS.

Statistics compiled by A. F. Crowell, deputy state horticultural commissioner, show the value of fruit produced in Spokane county, Washington, to be \$2,894,165, of which the apple crop netted \$1,827,065. This latter estimate is based on acreage of trees and the selling price of the Ben Davis variety, the cheapest grade in the Northwest. The apple crop of the State of Washington is valued at \$10,000,000. The prune crop was the second in value in Spokane county, bringing \$47,600, strawberries netted \$42,300, pears \$37,300, and peaches, cherries and vine fruits, \$938,800. Careful spraying and the better care of trees are two causes assigned for the crop, which is 25 per cent larger than in 1906. Mr. Crowell says in his report:

"Spokane county fell far short of supplying its home market during 1906, and it was necessary to ship in 66 cars of apples from the Yakima and Wenatchee. This fruit was shipped from a district where spraying was carefully attended. Had spraying been more thorough this year the increase would have brought to the grower fully \$500,000. However, the spraying has brought the production up to a supply equal to the home demand, while many cars of apples have been shipped to the markets of the world.

"I have not been able to get the exact number of acres of fruit for cultivation in Spokane county. The assessors' figures show 5,186 acres of apple orchard, 96 acres in pears, 119 acres in prunes, and 70 1-2 acres in strawberries. From the same source it is shown that there are 1,398 acres given over to the cultivation of miscellaneous fruits, including peaches and cherries. I am confident the figures given by the assessor are too low. Prof. C. L. Smith of Spokane says there are 250 acres given over to the cultivation of prunes alone along the lines of the Spokane & Inland Empire railway, and I believe the total number of acres of fruit is much larger than that given."

"The rigid inspection of nursery stock shipped into the county has caused the nurserymen to be more careful of the stock they send out, and, as a result, a better grade of trees are purchased by the fruit-grower," said Mr. Crowell. "More care is also being exercised in marketing fruit. During October and November the commission condemned and destroyed 911 boxes of apples and in September 595 boxes of pears infected with codlin moth and San Jose scale were destroyed. A large percentage of the pears destroyed was from the Snake river district.

"Although in force only two years, the inspection laws have been a great help to the fruit-grower and dealer, who are beginning to realize the benefits to be obtained from spraying. They realize that the inspected fruit brings a better price and establishes a record for clean fruit. When the inspection was taken up two years ago, fully one-half of the nursery stock sold to the grower had to be condemned because of the diseased condition of the trees. This year, aside from three shipments of trees, the

Is Your Name In The Above List? If Not, Why Not?

MAINTAINING SOIL FERTILITY.

In the first lecture of the series before the Worcester County Horticultural Society, on January 2, Dr. L. A. Clinton, director of Storrs' Agricultural Experiment Station, Connecticut, said that "the abandoned farms of New England show progress in New England agriculture. It speaks well for the New England farmer. These farms are not being abandoned because of lack of fertility of the soil, but simply because the cost of producing crops on these farms at the present time is too great and the farmers have discovered they can grow crops cheaper on other farms. When New England becomes densely populated somebody will grow crops on these fields that will surprise us.

"What is fertility? What is the measure of fertility? If we have a field that is fertile, what character does it possess that makes it fertile? If not fertile, what does it lack? What can we do to make it fertile? If we have good soil, how are we going to keep it fertile, so that it will be fertile for the next man and the next man?"

"The problem of fertility and the measure of fertility is, crop-producing power.

"Half of the successes in life do not come of the work you can do, but of the work you can have others do for you. Every farmer, gardener, or fruit grower has friends in the bacteria in the manure pile. As a matter of fact, not half the farmers think about these friends, the

Bacteria of the Soil.

who would like to do work for him if they would be let. Bacteria in the soil is something new. Ten years ago there was talk about bacteria in the milk, but nothing of bacteria in the soil."

Dr. Clinton then told about people who send samples of soil to experiment stations, asking them to analyze it and tell them what the soil needs. He explained that it isn't the farmer who has toiled 40 years that asks this question, but the city man who has gone to farming and who has read literature such as Harwood's "Wonders of Luther Burbank." He said a farmer would know that the experiment station can't tell them what their farm needs.

Dr. Clinton said he believes in under-draining a field if necessary and that he would take chances of a dry summer better with the field under-drained than not under-drained.

"The soil does not lose its fertility because of the plant soil which is removed with the crop we take from the soil," said Dr. Clinton. "All actual plant food could be returned at the expense of a few dollars in fertilizer." Dr. Clinton told the farmers, so far as possible to keep every foot of the farm covered with growing plants, all the time.

"When you take your corn off," said he, "have something else put right on there so it will be a growing plant and a covering on the ground all winter, beside the snow, to keep the soluble plant food and prevent its being drained off by the winter rain." He explained the great damage done by leaving a field exposed to winter rains,

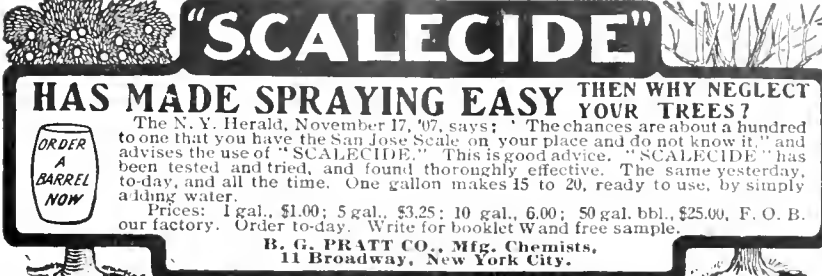

"SCALECIDE"

HAS MADE SPRAYING EASY THEN WHY NEGLECT YOUR TREES?

The N. Y. Herald, November 17, '07, says: "The chances are about a hundred to one that you have the San Jose Scale on your place and do not know it," and advises the use of "SCALECIDE." This is good advice. "SCALECIDE" has been tested and tried, and found thoroughly effective. The same yesterday, to-day, and all the time. One gallon makes 15 to 20, ready to use, by simply adding water.

Prices: 1 gal., \$1.00; 5 gal., \$3.25; 10 gal., 6.00; 50 gal. bbl., \$25.00, F. O. B. our factory. Order to-day. Write for booklet W and free sample.

B. G. PRATT CO., Mfg. Chemists,
11 Broadway, New York City.

when a covering of rye or any growing plant, even weeds, would protect it, and can be ploughed under and improve the soil.

Continuing, he said: "Now we all know the value of clover. Some people think clover can be grown in any field to bring it back, but that is not so. Clover grows well on fields that have good soil, and it clover grows in a field, you can be sure that that field is in good condition." Dr. Clinton explained that one of the best field coverings is rye.

"Suppose we find out that we have done all we can, and still something is needed. Then I say use fertilizers, but use them intelligently. In buying plant food I buy three things, nitrogen, phosphoric acid and potash, and mix it in any quantity I want it. I don't let somebody mix it for me. In fertilizing my fields I bear in mind the crop I intend to grow."

Regarding the use of lime, Dr. Clinton said: "It is good under three conditions: First, if the field is deficient in lime, which isn't so often, as not one field in 10,000 is deficient in the lime necessary; secondly, if the ground is acid, an application of lime would change that; third, if the soil is clayey, then lime will remedy that."

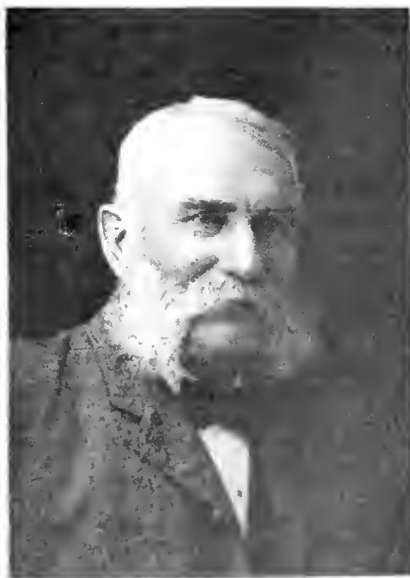

THE LATE EVERETT B. CLARK

A fire in the boiler-house of the greenhouses of Marcus L. Tirrell, Randolph, Mass., caused a damage to the building of about \$50. No estimate is given on the damage to the plants and flowers from smoke, water, cold and broken glass. Mr. Tirrell carried no insurance.

Obituary

W. H. Brown, florist, of Pittsburg, Pa., died on December 22, aged 66.

Levi Parsons, an employe in the Wilcox greenhouses, Omaha, Neb., dropped dead on December 19.

George C. Butz, a member of the horticultural staff of the Pennsylvania State College, died on December 14 at the age of 44.

B. F. Barton, for many years a successful salesman for Chase Bros., nurserymen, died on December 30 at West Windsor, Me., aged 81.

Mrs. Louise S., wife of Dr. Charles F. Millspaugh, curator of the botany department of the Field Columbian Museum, Chicago, died at her home on December 24, after a brief illness.

Alfred Plant, president of the Plant Seed Company of St. Louis, died on December 28 after an illness of eight months, at the age of 87. Mr. Plant was born in Lancaster (now Clinton), Mass., graduated with honors from Yale in 1847, entered the employ of Plant & Co. in 1856, where he was prominent in building up the business of which he ultimately became the head.

Francis Quinlan, of Lynn, Mass., whose death was recorded in our obituary columns last week, was possessed of a strong vein of humor, and many stories are told of his fertility as a joker.

The story is told that one summer's day he had been on an Elks' outing to Nahant and the party was on the way back to Lynn in a "barge." The weather was hot, and the barge was altogether too crowded for comfort. Suddenly Quinlan fell to the floor of the barge, apparently unconscious. The others lifted him onto the seat tenderly. Some one produced a bottle of whiskey and persuaded him to drink a portion. Others got water and bathed his forehead and wrists, and during the rest of the journey to Lynn he was given one entire side of the barge seat to lie on, while several kept him cool by fanning. When the barge reached Lynn they helped Quinlan out. No sooner did he touch the ground than he broke away and dashed up the street, leaving an amazed and angry crowd of Elks behind.

Quinlan was a florist in Lynn for many years and left considerable property.

WILSON'S PLANT OIL

If you want to make money there is only one way. That is to have clean stock and the only way to get it is by using WILSON'S PLANT OIL.

Mr. Andrew Wilson—Having used your Insecticide here, I can testify to its efficiency in destroying scale and other insects infesting plants.
New York Botanical Garden, Bronx Park, New York City, September 5, 1906.
Yours very truly,
GEO. A. SKENE.

Mr. Andrew Wilson:—Dear Sir—Your Plant Oil is certainly the most effective scale killer I have ever tried. Please send another five gallons.
Florham Farm, Madison, N. J., December 8, 1906.
Yours truly,
A. HERRINGTON.

PRICES: 1-2 pint cans, 25c; pints, 40c; quart, 75c; 2 quarts, \$1.25; gallon, \$2.00; five gallons, \$9.00. Cash with order.

ANDREW WILSON, Dept. 8,

SUMMIT, N. J.

Selling Agents for New England, R. & J. FARQUHAR & CO., 6 and 7 South Market St., Boston, Mass.

POSTS MADE DURABLE.

Woods Given Sixteen Years' Additional Service by Preservative Treatment.

Fence posts of many kinds of cheap woods which ordinarily would soon decay if set in the ground can be made to last for twenty years by a simple treatment with creosote. Most of the so-called "inferior" woods are well adapted to the treatment, and this is especially true of cottonwood, aspen, willow, sycamore, low-grade pines, and some of the gums. When properly treated, these woods outlast untreated cedar and oak, which are becoming too scarce and too much in demand for other uses to allow of their meeting the demand for fence posts.

Impregnation with creosote has been greatly cheapened by the introduction of the "open tank," which can be installed at a cost of from \$30 to \$45, or much less if an old boiler is used. A tank with a bottom 12 square feet in area will suffice for treating 40 or 50 6-inch posts a day, or double this number when two runs per day can be made. The absorption of creosote per post is about as follows: Eucalyptus, one-tenth gallon; willow, two-tenths gallon; sassafras, ash, hickory, red oak, water oak, elm, maple, four-tenths gallon; Douglas fir, quaking aspen, and black walnut, six-tenths gallon; sycamore, cottonwood, and lodgepole pine, seven-tenths gallon. The price of creosote is about 10 cents per gallon in the East and Middle West, 16 cents per gallon on the Pacific coast, and 27 cents per gallon in the Rocky Mountain States. The cost of treating a post will therefore vary from 4 to 15 cents. Properly treated, it should give service for at least twenty years.

Experiments of the Forest Service show that with preservative treatment the durability of lodgepole pine in Idaho is increased sixteen years. The cost of creosote is there relatively high, yet by treating posts there is a saving, with interest at 6 per cent., of 2 cents per post yearly. More important than the saving, however, is the fact that through preservative treatment other woods are fitted to take the place of cedar, of which the supply is rapidly becoming exhausted. A detailed description of experiments in preserving

fence posts, together with practical suggestions for treating them on a commercial scale, are contained in Circular 117 of the Forest Service. This publication can be obtained upon application to the Forester at Washington.—Press Review 27 (Circular 117 of the Forest Service).

GREENHOUSES BUILDING OR CONTEMPLATED.

Vincennes, Ind.—Albert Zepf, one house.

Blackington, Mass.—Mr. Stevens, range of houses.

Philadelphia, Pa.—John Boylan, one house.

So. Portland, Me.—J. W. Minott & Son, one house, 45x150.

The school ma'ams will flock to Amherst again next summer. The Massachusetts Agricultural College will supply them with four weeks of fun and study in the outdoor life. This plan of teaching teachers out of doors was tried with great success in the summer of 1907, and the plan now is to give more varied and extended exercises along the same line. There will be work in elementary agriculture, nature study, science and education suited for teachers, preachers and amateur farmers. This is a novel departure in school work, but one which is already giving good results.

A colored plate of John Waterer & Sons' rhododendron Fred Waterer was sent out as a supplement with The Garden, London, in its issue of December 21. The color is bright crimson and strikingly beautiful.

Harry Papworth, of New Orleans, shed his hail insurance too soon. The hail storm will get you if you only wait long enough, as Harry found out to his cost. The uninsured are trotting in the same class.

JOHN G. ESLER.

Look through the Buyers' Directory and Ready Reference Guide. You will find some good offers there also.



Cattle Manure In Bags

Shredded or Pulverized

Best and safest manure for florists and greenhouse use, absolutely pure, no waste, no danger. Write for circulars and prices.

The Pulverized Manure Co., 31 Union Stock Yards, Chicago



HEATING THE GREENHOUSE

thoroughly and economically during the coming winter is the problem now engrossing the mind of the florist who takes time by the forelock.

I am in a position to help you to the best solution of this problem, I have done it for others, I can do it for you.

It will be to your advantage to consult me and get quotations on your heating plant either erected complete or for material ready for erection.

I have the largest line of C. I. and steel greenhouse boilers on the market and can give prompt shipments.

WRITE ME TO-DAY.

John A. Payne

Horticultural Architect and Builder

Main Office and Factory:

260 274 Culver Ave., Jersey City, N.J.

Sash opening apparatus and all kinds of greenhouse structural material.



In ordering goods please add, "I saw it in HORTICULTURE."

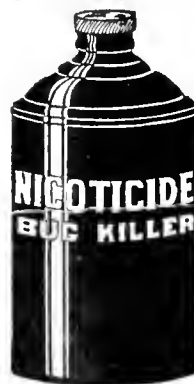

The Best Bug Killer and Bloom Saver

For PROOF

Write to

P. R. Palethorpe Co.
OWENSBORO, KY.

CARMAN'S ANTIPEST

For the Garden, Orchard and Greenhouse.

Non-poisonous and harmless to vegetation. Kills Green Fly, Aphides, Bark Lice, Thrip, Mealy Bug, Red Spider, Scale, Wire Worms, Ants and Slugs.

This is the Grower's Friend, handy to use, cheap and effective, mixes readily in water. Destroys all insect pests, and keeps down mildew. Circulars on application \$1.50 per gallon. Also in quarts, half gallons and in bulk.

PERFECTION CHEMICAL CO.,
FLUSHING, N. Y.

Eastern Agents:

W. W. RAWSON & CO., 5 Union St. Boston, Mass.

GREENHOUSE GLASS

Cheaper Now Than For Years

We are taking contracts for next Spring delivery.

WRITE FOR OUR PRICES

STANDARD PLATE GLASS COMPANY

26-30 Sudbury St. 61-63 Portland St.
BOSTON, MASS.



STANDARD FLOWER POTS

Packed in small crates, easy to handle.

Price per crate		Price per crate	
1500 2 1/2 in. pots in crate	\$4.88	120 7 in. pots in crate	\$4.20
1500 3 1/4 " " "	5.25	60 8 " " "	3.00
1500 2 3/4 " " "	6.00	HAND MADE	
1000 3 " " "	5.00	48 9 in. pots in crate	\$3.60
800 3 3/4 " " "	5.80	48 10 " " "	4.80
500 4 " " "	4.50	34 11 " " "	3.60
320 5 " " "	4.51	34 12 " " "	4.80
144 6 " " "	3.16	12 14 " " "	4.80
		6 16 " " "	4.50

Seed pans, same price as pots. Send for price list of Cylinders for Cut flowers, Hanging Baskets, Lawn Vases, etc. Ten per cent. off for cash with order. Address **Hilfinger Bros., Pottery, Fort Edward, N.Y.** August Rolker & Sons, Agts., 31 Barclay St., N. Y. City.

Standard Flower POTS

If your greenhouses are within 500 miles of the Capitol, write us, we can save you money

W. H. ERNEST,

28th and M Street WASHINGTON D. C.

PATENTS

Trademarks and Copyrights

Send other business direct to Washington. Saves time and insures better service. Personal attention guaranteed. Twenty-five years' active service. SPECIALTY: "Working on the Failures of Others."

SIGGERS & SIGGERS

PATENT LAWYERS

Box 9, National Union Building
Washington, D. C.

INSURANCE

of your plants from **FREEZING** in cold weather at a trifling cost. Use a celebrated

LEHMAN WAGON HEATER

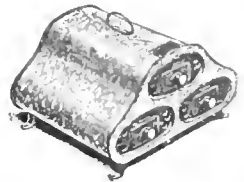

There is no danger of fire; no smoke, dirt or gases to injure plants. They burn **Lehman Coal**, which costs less than 1/2 cent per hour.

400,000 Lehman heaters are in actual use by **Florists**, Horsemen, Agriculturists and Physicians. Have you one? Write for new booklet with prices to-day.

LEHMAN BROS.

Manufacturers

10 Bond St., NEW YORK

Beware of Imitations.

J. W. ERRINGER

Gen. West. Sales Agent

45 E. Congress St., CHICAGO

Mention "Horticulture" when writing.

NOW IS THE RIGHT TIME TO FIGURE

MATERIAL

AND PLAN FOR THE BUILDINGS OF THIS YEAR

FOLEY'S } QUALITY AND WORK THE BEST.
PRICES RIGHT AND LOWEST.
ESTIMATES WILL PROVE. TRY US.

Foley Ventilating Apparatus Unequaled

Will ventilate any size of house easily. Send for Circular.

THE FOLEY MFG. CO. Western Ave. 25th & 26th Sts. CHICAGO

S. JACOBS & SONS

Manufacturers of GULF CYPRESS

GREENHOUSE MATERIAL

Jobbers of

Glass, Boilers, Pipes, Etc.
Catalogue and Prices Upon Request.

1365-1379 Flushing Ave.
BROOKLYN, - NEW YORK

ANCHOR GREENHOUSE HOSE

WEARS WELL.

PLANT BED CLOTH

Protects from Cold and Dampness.

MINERALIZED RUBBER CO.

18 Cliff Street New York

BOSTON PLATE & WINDOW GLASS CO.

GREENHOUSE GLASS

German and American

261 to 287 A St., BOSTON 20-22 Canal St.

In ordering goods please add, "I saw it in HORTICULTURE."

The **FLORISTS' HAIL ASSOCIATION OF AMERICA**, insurer of 28,000,000 sq. ft. of glass. For particulars address **John G. Esler, Sec'y, Saddle River, N.J.**

Anything of Value

to the profession

CAN BE SOLD

through advertising in

Horticulture

CYPRESS SASH BARS 82 feet or longer
HOT BED SASH
PECKY CYPRESS BENCH LUMBER

GREENHOUSES

ERECTED AND EQUIPPED COMPLETE IF DESIRED.

Write for Circular "D" and Prices

The A. T. STEARNS LUMBER CO.
NEPONSET, BOSTON, MASS.

I. CASSIDY

Designer and Builder
OF

Iron and Wood Greenhouses.

Office and factory, 215 to 221 Randolph Ave.
JERSEY CITY, N. J.

GREENHOUSE CONSTRUCTION LUMBER

John C. Moninger Co.
117 E. Blackhawk St., CHICAGO

R. TONAWANDA, N. Y.

TORONTO, ONT.



Holds Glass Firmly
See the Point
PEERLESS

FULL SIZE
NO. 2

Glazing Points are the best. No rights or lefts. Box of 1,000 points 75 cts. postpaid.

HENRY A. BREER,
714 Chestnut St., Phila., Pa.

H AND O

HERE IS SOMETHING MORE TO THINK OVER

Did you ever stop to think that the outsider often knows more about your business than you do? Yes, actually knows more about its weak spots, that is, he knows better why you are not *more* successful. In other words, when you are constantly so near your own interests, it is often impossible for you to get the accurate view others can. You get wound up in prejudice, a habit, a rut. You know something is wrong, but become powerless to locate it. We are not only greenhouse builders, but we are trouble finders. We are not authority on how to grow things, but we do know the best house in which the best things grow, and how to build that sort of house. Can tell you where your present construction is wrong and build you a house that will cut down running expenses, reduce repair bills and put you in a position to meet competition of the keenest. You need us! Write!

HITCHINGS AND CO.

GREENHOUSE DESIGNERS AND BUILDERS.
Manufacturers of Heating and Ventilating Apparatus.

1170 Broadway, NEW YORK.



HERE IS THAT NEW CATALOG

that we have been talking about—let us give you just a little scan of its contents. There are five pages of a mighty interesting chat with Mr. Burnham, one of the pioneer greenhouse builders—then come three pages on "Planning and Locating your Greenhouse" which contains a good bit of information as a moneysaver to you. The next 26 pages cover every conceivable sort of greenhouse suitable for either private places or institutions of various kinds—these pages start with a single compartment house 18 feet wide and 33 feet 4 inches long, and end with a series of selections covering ranges for growing every sort of thing. There is

a page on right benching, another on the heating question, and the last fourteen pages contain the real meat of the catalog, and tell exactly what our Sectional Iron Frame Construction is—each structural part is described and illustrated by a detail cut. The various types of side wall constructions and different styles of houses are freely illustrated. No pains have been spared to make this catalog not only a text book of perfect construction, but a decidedly interesting book to read. The illustrations are many and printed in the finest way possible. If the greenhouse question interests you, and you contemplate erecting one, we want you to have this catalog.

We make every part of a greenhouse but the glass. We sell any part.

LORD & BURNHAM CO.
Greenhouse Designers and Manufacturers

1133 BROADWAY, cor. 26th Street, N. Y.
BOSTON Branch: 819 Tremont Building
PHILADELPHIA Branch: 1215 Filbert St.



What a clean cut, convincing proposition this is! What a total absence of any attempt to secure ornamentalness—yet how downright graceful and beautiful every line and structural detail of this U-Bar construction is. Imagine a house of other constructions with heavy gutter at the eave, and compare it with this curved eave U-Bar house absolutely free of any obstruction, from ridge to sill. It is just this freedom—the wide spacing of glass and unequalled lightness that makes them the superior growing houses they are. We erected this range on one of the largest estates in Newport and carried out the owner's wish to provide for additions, by framing in a part of the connecting passages which will fit the future houses, and using them at present for side entrances. An 11 foot house, used for propagating, joins the potting room with the center compartment. But to really know U-Bar strong points, go and see a house for yourself, or next best send for the catalog. Pierson U-Bar Company, Designers and Builders U-Bar Greenhouses, Metropolitan Building, 4th Avenue and 23rd Street, New York.



HORTICULTURE

Vol. VII.

JANUARY 18, 1908

No. 3



CATTELYA PERCIVALIANA ALVA

*Devoted to the
FLORIST, PLANTSMAN,
LANDSCAPE GARDENER
and
Kindred Interests*

*Published
EVERY SATURDAY
At 11 Hamilton Place,
BOSTON, MASS.
Subscription, \$1.00*

Easter Azaleas and Spring Forcing Plants



Our stock this season is handsomer than ever. Anybody in want of a quantity will do well to inspect our plants before placing their order. We have only popular American varieties: **Schryvertiana**, **Simon Mardner**, **Vervaeana**, **Mme. Van der Cruyssen**, **Deutsche Perle** and others.

	Per doz.	Per 100		Per doz.	Per 1000
8-10 in. diam.	\$3.50	\$25.00	15-16 in. diam.	\$9.00	\$75.00
10-12 "	4.50	35.00	16-18 "	12.00	90.00
12-14 "	6.00	45.00	18-20 "	25.00	200.00
14-15 "	7.50	60.00	20-24 "	36.00	300.00

Order early to save heavy express charges; impossible to ship by freight in cold weather.

FORCING ROOTS AND POT GROWN SHRUBS

	Doz.	100	1000		Doz.	100	1000
Azalea Mollis , \$4.00, \$9.00, \$12.00				Deutzia gracilis , pot grown	\$12.00		
" " standard form	12.00			" Lemoinei	15.00		
" " chinensis	12.00			Gladiolus , The Bride			\$7.50
" " Anthony				" rubra			6.50
" " Koster	12.00			Kalmia latifolia , fine budded plants,	\$9.00, 12.00		
" Rustica	12.00			Lilacs pot grown	9.00		
Very handsome budded plants.				Lily of the Valley , Berlin Pips			14.00
Crataegus , Paul's Scarlet (Double scarlet Hawthorn) pot grown,	\$12.00, 18.00			" " Hamburg Pips			12.00
Dielytra spectabilis , large clumps,	\$10.00			Viburnum opulus (Snowball) bush form, pot grown	6.50		

Rhododendrons, handsome budded plants in fine forcing varieties, \$9, \$12, \$15, \$18, \$24, \$30 per dozen.

ENGLISH MANETTI STOCK, right size for grafting, \$10.00 per 1000

Roses Grown in Our Nursery for Easter Forcing

- BABY RAMBLERS**, tree form, pot grown, 50c. each
- Bushy form fine field grown plants
- CLOTHILDE SOUPERT**, field grown, 2 year old
- DOROTHY PERKINS**, strong field grown plants, 2 years old, 7-8 feet
- HERMOSEA**, field grown, fine for pots, 2 years old
- RED KAISERIN**, strong 2 year old field grown plants

Dozen	100
\$5.00	\$15.00
2.00	15.00
1.50	12.00
3.00	20.00
1.50	12.00
3.50	25.00

LADY GAY, strong field grown plants, with well ripened wood, 2 years

Dozen	100	1000
\$3.50	\$25.00	

H. P. ROSES, imported, field grown, 2 years old

12.00 \$100.00

Capt. Christy, Duchess of Edinburgh, Gen. Jacqueminot, Mme. Gabriel Luizet, Mrs. John Laing, Perle des Blancches, Ulrich Brunner, Caroline Testout, Frau Karl Druschki, La France, Magna Charta, Paul Neyron, Rothschild.

KENTIAS

The handsomest lot in the country. all sizes, from 15 inches to 15 feet. Inspect our stock before buying.

BOXWOOD, Standard

All sizes..... from \$1.00 to \$5.00 each

BOXWOOD, Pyramidal

These plants are conceded to be the finest ever imported to this country. (Exceptional value.)
 2 ft. \$.75 each 4 ft. \$3.00 each
 3 ft. 1.00 each 4 1/2 ft. 4.00 each
 4 ft. 1.50 each 5 ft. 5.00 each
 5 ft. 2.00 each 6 ft. 6.00 each

BOXWOOD, Bush

Handsome, bushy specimens.
 10-12 in. 1.50 each 15-18 in. 3.50 each
 12-15 in. 2.50 each 18-22 in. 7.50 each

BAY TREES

We have a large number in all sizes. Ask for prices.

VISITORS INVITED.

ASK FOR CATALOGUE.

BOBBINK & ATKINS, Nurserymen and Florists, Rutherford, N. J.

Just Received in Splendid Condition

15,000 AZALEAS

in all sizes and varieties

25c. up to \$2.00 each

Also Kentias, Rubbers, Araucarias, Pandanus, Boxwood, Euonymus, Crotons, Arecia and Eurya latifolia.

Extra good value in large

Specimen and Decorative Palms

A. LEUTHY & CO.

Perkins Street Nurseries, Roslindale, Mass.

GODFREY ASCHMANN

Importer and Wholesale Grower and Shipper

of Araucaria Excelsa, Compacta, Robusta and Glauca; Kentia Forsteriana and Beluoreana Azalea, Indica, etc.; Cultivator of Boston, Scottii, Barrowsii, Elegantisima and Whitmanii Ferns. Ferns for dishes, Cocos, etc. Write for prices.

1012 Ontario St., Philadelphia

AUGUST ROLKER & SONS

Supply the trade with

PLANTS AND BULBS

For greenhouse or outdoor use, imported to order. Send for estimate. Address—
 Barclay St., oP O. Box 752, New York

LILIUM AURATUM

9-11 \$75 per 1000

ROSEUM and RUBRUM

9-11 \$65 per 1000

MULTIFLORUM

7-9 \$45 per 1000

O. RUSCONI, 128 West 6th St., CINCINNATI, OHIO

ANTON SCHULTHEIS

Wholesale Plant Grower,
 College Point, - New York.

Price List of Foliage, Flowering and Decorative Plants sent free on application.

AZALEAS GHENT-FLOLLIS And Natives PYRAMIDAL BOX LARGE STOCK All Sizes

ROSES STRONG PLANTS--BEST VARIETIES Send for List and Prices

Acres of HERBACEOUS PERENNIALS. LARGEST VARIETY IN NEW ENGLAND

Send for Catalogues. **BAY STATE NURSERIES** NO. ABINGTON MSAS.



ADIANTUM FARLEYENSE

DREER'S MIXED FERNS FOR DISHES

There always has been a scarcity of **First Class Ferns** after the Holidays and in anticipation of this we have this season prepared an extra quantity of both 2 1/4 and 3 inch pot plants which are now in prime condition, better than we have ever been able to supply at this season of the year. We offer

2 1/4 in. pots in choice mixture, **\$3.50 per 100** ; \$30.00 per 1000
 3 " " " " " **\$6.00 " " \$50.00 " "**

We also have an exceptional fine lot of

Adiantum Farleyense

6 inch pots, fine specimens, **\$1.00 each**
 8 " " " " " **\$2.00 " "**

Nephrolepis Amerpohli

6 inch pans, elegant stock, **\$1.00 each**

For a complete list of seasonable stock see our **Quarterly Wholesale List** just issued.

HENRY A. DREER

714 Chestnut Street, : PHILADELPHIA

Hardy Roses

American Grown—Superior to Imported

We have unsold at the present time the following varieties—all field grown plants, grown in our nurseries at Rochester, N. Y.:

- | | |
|---------------------|-----------------------|
| Anne de Diesbach | Prince Canille |
| Olo | Ulrich Brunner |
| Fran Karl Druschki | Crimson Rambler |
| General Jacqueminot | White Rambler |
| John Dopper | Yellow Rambler |
| Mme. G. Luize | Philadelphia Rambler |
| Marshall P. Wilder | Common Sweet Brlar |
| Mrs. John Long | Mme. G. Bruant |
| Paul Neyron | Wichuriana (The Type) |

These plants are in our storage cellars and can be shipped at any time. Prices on request.

ELLWANGER & BARRY

Nurserymen—Horticulturists

Mount Hope Nurseries, Rochester, N. Y.

DAHLIAS.

Now is the time to place your order for bulbs which will insure you getting named varieties in any quantity; prompt delivery.

DAVID HERBERT & SON,

Successors to L. K. Peacock, Inc.

ATCO, N. J.

100,000 DAHLIAS

Premium Stock, guaranteed true to name.

500,000 large Flowering Gladioli, hundreds of colors and variations mixed. Wholesale prices on application. Order now for spring delivery. Catalogue free.

J. L. MOORE, Northboro, Mass.

JOHN SCOTT

Grower of PALMS, FERNS and Other Decorative Stock

NEPHROLEPIS SCOTTII All the Year Round

Rutland Road and East 45th St.

Telephone 2890 Bedford **BROOKLYN, N. Y.**

NEP. WHITMANI

2 1/4 in., \$5.00 per 100

NEP. WHITMANI

3 1/2 in., \$25.00 per 100

BOSTON FERNS

2 1/4 in., \$3.00 per 100

H. H. BARROWS & SON Whitman, Mass.

JOHN WATERER & SONS, Ld. American Nursery, Bagshot, England

Are Specialists in the

REALLY HARDY VARIETIES

of Rhododendron Hybrids and in Select Varieties of Hardy Border Plants.

NEW NEW

RAMBLER ROSE "NEWPORT FAIRY"

To be disseminated Spring, 1908. Ask for illustrated pamphlet and prices

JULIUS ROEHR'S CO., Rutherford, N. J.

ROSES

Selected Stock for Forcing

CRIMSON RAMBLER and DOROTHY PERKINS

3 to 4 ft. \$1.50 per 10, \$12.00 per 100; 4 to 5 ft. \$2.00 per 10, \$15.00 per 100

HYBRIDS—All Leading varieties, \$1.50 per 10, \$12.00 per 100

General Catalog and Trade Lists on Application

The **NEW ENGLAND NURSERIES, Inc., Bedford, Mass.**

WE are now booking orders for Grafted and Own Root Rose stock.

A. N. PIERSON

C. O MWELL, - - - CONN.

Established 40 Years

Rose Hill Nurseries

New and Rare Plants

NEW ROCHELLE, N. Y.

New York Office, Siebrecht Building, 425 Fifth Avenue

Hardy Rhododendrons Azaleas Conifers, Clematis, H. P. Roses, Shrubs and Herbaceous Plants from our

HOLLAND NURSERIES

Prices Moderate

P. OUWERKERK, 216 Jane St., Weehawken Heights, P. O. No. 1, Hoboken N. J.

CANNAS

Send for our List and Prices

The **CONARD & JONES CO.**
 WEST GROVE, PA.

PRICES QUOTED IN THESE COLUMNS ARE FOR DEALERS ONLY

When Writing to Advertisers Please Mention Horticulture

WINSOR and WHITE ENCHANTRESS Strong Rooted Cuttings Now Ready For Delivery

WINSOR has proved to be the finest carnation in the light pink class. We sold a large quantity of it last year, but there will be a much larger sale for it this year. At the English Carnation Show held in December, it was the winner in the light pink class. It is doing well everywhere and will supplant everything in that color.

WHITE ENCHANTRESS will occupy the same position among white carnations that Enchantress does among flesh pinks. It has all the good qualities of the common Enchantress,—long stem, earliness, large size, freedom, etc. In our opinion, it is by far the best white carnation ever introduced.

We have a splendid stock of both Winsor and White Enchantress ready for immediate delivery, and will guarantee perfect satisfaction with the cuttings supplied. Do not wait, because the demand for these varieties is bound to be enormous. **Order early, while we can promise immediate delivery,** and secure gilt-edged stock. We have a large stock of both of these varieties, and all our cuttings are heel cuttings, taken from flowering stems. On account of the quantity that we are growing, we are not obliged to over-propagate, and our stock is in the most perfect and healthy condition.

Strong rooted cuttings from sand, \$6 per 100, \$50 per 1000. Extra strong transplanted cuttings from soil, \$7.50 per 100, \$60 per 1000. Strong established pot-grown plants \$9 per 100, \$75 per 1000.

F. R. PIERSON CO., - Tarrytown-on-Hudson, - NEW YORK

LLOYD

IS THE REAL THING
The Carnation for every one to grow

LLOYD is a commercial white, with a fancy flower

The only ever-blooming, large-flowering white in existence

Will take the place of all other whites now in commerce. Every New Bedford grower has bought stock. Come and investigate.

**A KEEPER
A SHIPPER
A BLOOMER**

It will bring the shekels when all others fail

\$2 pr 12. \$12 pr 100. \$100 pr 1000
Unrooted Cuttings
\$6 per 100. \$50 per 1000.

H. A. JAHN

NEW BEDFORD, - - MASS.

CATALOGUE OF

**New Chrysanthemums
Roses, Etc.**

Now ready, I am headquarters for the new singles, and carry the cream of the world's novelties. If you are interested send for my list. It's yours for the asking.

CHARLES H. TOTTY
Madison. - - - N. J.

FERNS

Boston, 4 inch 12c, 5 inch 25c.
Piersonii, 3 inch 8c.
Elegantissima, 2 1/2 inch 6c, 3 inch 10c,
4 inch, 15c.

BAUR FLORAL CO., Erie, Pa.

Select Stock of Strong Well Rooted
Carnation Cuttings.

	Ready Now.	Per 100	Per 1000
Andrew Carnegie Scarlet			
Harlowarden	\$12.00	\$100.00	
Aristocrat, bright cerise	6.00	50.00	
Winsor, pink	6.00	50.00	
Beacon, orange scarlet	6.00	50.00	
White Enchantress, pure white	6.00	50.00	
Welcome, pink	6.00	50.00	
Red Chief, Christmas scarlet	6.00	50.00	
Rose Pink Enchantress	3.00	25.00	
White Perfection	3.00	25.00	
Enchantress	3.00	25.00	
Daybreak Lawson	3.00	25.00	
Victory, scarlet	3.00	25.00	

CHICAGO CARNATION COMPANY,
A. T. PYPER, Mgr. JOLIET, ILL.

CARNATIONS ROOTED CUTTINGS

Winona, color, true clear pink, comes nearest to Fiancee but a different type flower. Growth on order of Scott but vastly improved in every respect. Early flowers in quantity and on long stems. Does not burst its calyx. Fine, shapely, active growth. In color and productiveness it is without an equal. Orders booked now and filled in strict rotation. \$12 per 100, \$100 per 1000.

White Perfection, pure white. We have a large stock. \$3 per 100, \$25 per 1000.

F. DORNER & SONS CO.

LA FAYETTE, IND.

Carnation Cuttings

Both standard varieties and novelties. Stock guaranteed to be first-class. Address,

S. S. SKIDELSKY

1741 North 18th Street, Philadelphia

ANNOUNCEMENT

Our new seedling carnation, **10READOR**, will not be disseminated until January 1909. For further particulars address, **The H. WEBER & SONS CO., Oakland, Md.**



A PENNY SAVED IS WORTH TWO EARNED

Save your Pinks from Splitting by using the **M. & D. ARTIFICIAL CALYX** Free Sample. Send for one and be convinced of its merits. **MAXFIELD & DIMOND** Pat. Sept. 18-06 P. O. Box 304-D WARREN, R. I.

Rooted Carnation Cuttings

<u>Pink</u>	100	1000
Aristocrat	\$6.00	\$50.00
Winsor	6.00	50.00
Rose Pink Enchantress	3.50	30.00
Enchantress	3.00	25.00
Lawson	2.50	20.00
Joost	2.00	15.00

White

White Perfection	3.00	25.00
" Enchantress	6.00	50.00
" Lawson	3.00	25.00
Queen	2.00	18.00
Boston Market	2.00	18.00
Louise	2.00	18.00
Lt. Peary	3.00	25.00
Bountiful	2.50	20.00

Red

Beacon	6.00	50.00
Victory	3.00	25.00
Robert Craig	3.00	25.00
Flamingo	2.50	20.00

Miscellaneous

Patten	2.50	20.00
Harry Fenn	2.50	20.00
Harlowarden	2.50	20.00

Stock Guaranteed—Prompt Deliveries

THE LEO NIESSEN CO.

WHOLESALE FLORISTS

1209 Arch St., PHILADELPHIA

JOHN E. HAINES
Bethlehem, Pa.

is the place to order rooted-cuttings of the following varieties for 1908.

John E. Haines, red } Per 100 Per 1000
Imperial variegated } \$6.00 \$50.00
Pink Imperial, Pink }
Enchantress, Light Pink }
Place your orders early for Jan. delivery.

PURE WHITE ENCHANTRESS

ROOTED CUTTINGS

\$6.00 per 100 \$50.00 per 1000

JACOB SCHULZ

644 4th Ave., LOUISVILLE, KY.

Prices Quoted in these Columns are for Dealers Only. When Writing to Advertisers Please Mention HORTICULTURE.

Cypripedium Fairrieianum Hybrids



CYPRIPEDIUM X NIOBE.

Few hybrid cypripediums are so interesting as the Fairrieianum hybrids, which, until quite recently, were almost the only representatives of the much talked of "Lost Orchid" in cultivation. Some three years ago an interesting note appeared in HORTICULTURE by E. O. Orpet, in which the possibilities of the habitat of Cypripedium Fairrieianum being rediscovered were discussed. Mr. Orpet was optimistic and cited the case of Cattleya labiata which was also "lost" for quite a while. Within a short time the news came that Fairrieianum had been found, causing a great deal of newspaper comment and excitement in the orchid world. The coincidence passed without comment.

The accompanying illustration gives a good idea of the beautiful hybrid X Niobe which resembles its pollen parent and has much of the vigor of the seed parent; also, like many hybrids, has a better constitution than either. The Fairrieianum hybrids, although comparatively rare at the present time, will, during the next few years become plentiful, as Cypripedium Fairrieianum is now being imported and grown by thousands and strange to say has not as yet exhibited any tendency to sicken and die as was expected.

The fact that its habitat and environs are now known

has much to do with this as no doubt many plants of former importations died because they were grown too hot and close. Coming from a high altitude a cool airy treatment is necessary.

An interesting circumstance has come to light since the rediscovery of this famous cypripedium. Cypripedium hirsutissimum which was introduced at the same time as Fairrieianum has been for years grown and cherished by the family of Mr. Fairrie as Fairrieianum. They only discovered their mistake when illustrations of the rediscovered plants appeared.

The seed parent of the subject of our illustration, Cypripedium Spicerianum, succeeds best under somewhat cool treatment. The hybrid, however, is best grown in the warm East Indian compartment. All the Fairrieianum hybrids are free flowering and may some day rival C. insigne and C. Leeaanum as commercial varieties. In Niobe the habit is good, stem long, dorsal sepal white, veined and partly suffused with rich purple, lip brownish, petals whitish green ribbed with brownish purple, staminode greenish white with dark red centre.

Some of the best Fairrieianum hybrids are vexillarium, Juno, Arthurianum, Baron Schroder, H. Ballantyne, Edwardii and Amesiana. As a seed parent Fairrieianum has not been much used. The records give only two, Constableanum and Aaseni, which are not common. The possibilities of the future, however, are unlimited.

James Hutchison

Salvia Zurich

Anyone growing salvias should try this splendid variety which was recently introduced. We have found it preferable to the older standards in our last year's trials and so have some other members of the craft here and we have all discarded Bonfire and Lord Fauntleroy, which we grew up to the present time. Salvia Zurich bloomed much earlier, though the cuttings were not nearly so old and kept on blooming just as long as the rest. As our stock last season was limited we used it for our particular customers who must have a scarlet sage bed every year and they were well pleased to have them in bloom so early in June where other years the beds made little show before the end of August. It does not grow as tall as the older kinds and seems to bloom freer, and is just as scarlet as it can be. We recommend to our brother florists a trial. It is no more experiment: we have tried it and know it is good.

J. L. Schiller

Toledo, O.

HORTICULTURE

VOL. VII

JANUARY 18, 1908

NO. 3

PUBLISHED WEEKLY BY
HORTICULTURE PUBLISHING CO.
 11 Hamilton Place, Boston, Mass.

Telephone, Oxford 292
 WM. J. STEWART, Editor and Manager

SUBSCRIPTION PRICE

One Year, in advance, \$1.00; To Foreign Countries, 2.00; To Canada, \$1.50

ADVERTISING RATES

Per Inch, 30 inches to page . . . \$1.00.
 Discounts on Contracts for consecutive insertions, as follows:
 One month (4 times) 5 per cent.; three months (12 times) 10 per cent.;
 six months (26 times) 20 per cent.; one year (52 times) 30 per cent.
 Page and half page spaces, special rates on application.

COPYRIGHT, 1908, BY HORTICULTURE PUB. CO.

Entered as second-class matter December 8, 1904, at the Post Office at Boston, Mass., under the Act of Congress of March 3, 1879.

CONTENTS

	Page
FRONTISPIECE— <i>Cattleya Percivaliana</i> Alva.	
CYPRIPEDIUM FAIRRIEANUM HYBRIDS—James Hutchison—Illustrated	61
SALVIA ZURICH—J. L. Schiller	61
THE PAEONY DISEASE—C. Betscher	63
FERTILIZING WHILE WATERING—Dudley M. Pray	63
NEWS OF THE CLUBS AND SOCIETIES:	
Gardeners' and Florists' Club of Boston—St. Louis Florists' Club—Newport Horticultural Society—Pasadena Gardeners' Association—The Carnation Meeting at Washington—Connecticut Horticultural Society—American Rose Society	64
Society of American Florists; The New Directors—American Carnation Society—Pittsburgh Florists' and Gardeners' Club—New Bedford Horticultural Society—Pennsylvania Horticultural Society	65
New York Florists' Club—New York State Fruit Growers' Association—Nassau County Horticultural Society—Club and Society Notes	66
COMPETITION FAIR AND FOUL—S. S. Skidelsky	67
MASSACHUSETTS EXPERIMENT STATION—Wm. P. Brooks	68
SEED TRADE	70
European Crop Conditions	70
A Maine View on Free Seeds	72
ORNAMENTAL HORTICULTURE—Professor Herman Beekenstrater	72
OBITUARY—Victor S. Dorval, Portrait—Marston B. Bunker—Sol. De La Rosh—Fred Thayer—Mrs. Lydia B. Manning	74
FLOWER MARKET REPORTS:	
Boston, Buffalo, Detroit, Indianapolis, New York, Philadelphia	77
Twin Cities, Washington	84
CATTELYA PERCIVALIANA ALVA	84
BOSTON HEAD LETTUCE AT IRONDEQUOIT, N. Y.—H. R. Peachey	85
MISCELLANEOUS	
News Notes	74-75
Business Changes	75
Personal	84
A Record Florist	84
"The Happy Gardener"	84
List of Patents	85
Greenhouses Building or Contemplated	85
New Heating Apparatus	85

We trust every one of our readers who conducts a greenhouse for plants or flowers will carefully read the series of articles on the use of fertilizers now being contributed by Dudley M. Pray. The third in the series appears in this issue. These contributions are written for HORTICULTURE by a gentleman who has

for years made a special study of this subject from a practical florists' standpoint and present the information in a quite different style from that followed in the ordinary Experiment Station analyses. At the beginning of the year we promised our readers some good things for 1908. This is one of several in prospect that we did not specify by name. We have others in store also highly valuable. Tell your friends to subscribe for HORTICULTURE for every issue will contain much useful reference matter.

Profitless work

The ambition shown by some flower growers to force tulips into bloom and into market earlier in the season than it is possible to get a passable flower has always seemed incomprehensible to us, for there is no incentive of price or demand. Quantities of stemless abortive flowers prematurely driven out of rootless bulbs are not an uncommon sight in the markets at the present time. The best price at which they can be sold to the cheap cemetery florists cannot possibly cover more than the bare cash cost of the bulbs and is often less than that. When we consider that two or three weeks more allowed these bulbs to develop their flowers would have enabled them to produce something creditable and saleable we are at a loss to understand the wasteful course of the grower who is supposed to do these things for the profit there is in it.

Making a record

At this time, when new officers are beginning their administrations and new and ambitious policies are being introduced in our clubs and societies an excellent opportunity is offered for society members generally to forget past differences, drop old and threadbare controversies and with cordiality and enthusiasm give a helping hand to any movement which promises to promote the prosperity and usefulness of the organization and help the objects for which it exists. And right here, it may not be out of place to remind our readers that mere numbers must not be depended upon as evidence of any great or permanent prosperity in any organization. Some officers rely much upon their success in inducing many accessions to the ranks from among their friends. This may or may not have permanent value according as the accessions are due to simply the personal popularity of an official or mean support for some well-planned and far-reaching policy calculated to redound to the lustre of the society and the good of its constituency. Presidents are, or should be, chosen for something more than to sit on a platform and preside at meetings and members in electing their fellows to these positions of honor and duty should understand that they are themselves assuming other responsibilities than of simply flocking to the meetings and participating in the general pleasantries, admirable as that undoubtedly is. Let us hope that every newly installed officer together with those over whom he presides may see to it that his year is made notable for some distinct achievement to which in after years he and his supporters may revert with a proud consciousness that it furnishes ample justification of his elevation to official honors.

The Paeony Disease

I have noticed a number of writings lately in various farm and trade papers harmonious with the article in a recent issue of HORTICULTURE anent the new paeony disease, and quite a number of growers and customers have written me regarding it. We have had only a few plants to show this "disease" that really is only a symptom, a symptom more of carelessness or thoughtlessness than a real disease. Our land progresses from a very light to a very heavy loamy clay, from a gravel or sand subsoil to soapy stiff clay, hence we are very certain that soil has nothing to do with the disease.

Where found this symptom was on a few plants that we imported from France; details, as in our own case each had manured quite heavily after planting or had given each plant a heavy mulching leaving the manure to rot over the crowns. Usually after a wet spell they show a white spawn around the stems at about the surface line, in a few days the plants show a delicate sulphury color of stem and leafage, a few days later they blight black to the roots and the roots often show a brown rot. This usually is the beginning of the end; however, if the plant is lifted and planted into a soil where there is little vegetable matter it may be revived but the dead matter should be cut off and lined lightly before planting.

There is quite a different result with some varieties apparently from the same mistreatment. The plants only partially blight, largely just the tips of the leaves, the rootage in about the same proportions. The microbes get through the bases of the season's growth, nearly eating them apart from the old plant; this causes a dense growth, quite dwarfed, the leaves as they mature becoming a much lighter color than plants not affected. Usually one would think the plants are badly mixed but usually they revive but rarely bloom for several years after it is noticed.

A number of writers have written articles regarding the latter symptom, calling it paeony rosette, stating that plants so affected are worthless and should be dug and thrown away. My observations were such that I let the latter plants stand, removing the soil around the plant as much as possible, then putting soil back that has very little manure in it. It is a very good idea to distribute a good application of slacked lime about the plant, boeing it in as close to the stems as possible; this kills the disturbing agencies and the plants revive. Paeonies that are in low ground or low places where water is allowed to cover the plants for any length of time show these same symptoms but it is generally fatal.

We use manure direct from the stable or well rotted—whichever we have—distributing it over the plantage about November to January but usually draw the soil to the plants with shovel plow before manuring. I think many paeonies are over-manured hence the indifferent results. Since we noticed the bad results with manure when applied to young plants we usually try to get a crop of corn or potatoes previous to planting with paeonies. This finds the soil in very fine condition, few insects and bacteria. We give no manure before the following fall, and then after the ground is frozen.

I think most of the parties who have had trouble with paeonies have received them from growers growing them for long periods in one place or that have them growing in very well enriched soil. Where paeonies are

given good cultivation manuring is not essential to get good results.

I have no fears regarding paeony diseases. We have five acres very closely planted; have stock from at least twenty-five growers but the loss of plants has been practically nil. Officialis Rosa Superba is the only sort we have had trouble with but this seems general and evidently is a constitutional disease.

C. BETSCHER.

Fertilizing While Watering

In order to apply to a given area a certain weight of soluble plant food in the course of the usual watering, both the amount of water then used on that area and also its fertilizing value per gallon must be known, or a corresponding figure. If one filling of a tank would please "go even" on certain benches or convenient areas it would be simple to put the amount desired for that area in that tank and not bother about the strength as long as the watering was sufficient. In this case the amount put in the tank would be the amount that would reach the area. But this nice "coming out even" happens more often in the arithmetic than elsewhere and as identical conditions of watering are rare it will nearly always be necessary to know both the strength of food at the tank end and also the gallons applied to the soil to calculate what amount of food reaches the area at last. Similar remarks would apply to the use of Kinney pump and such devices. Just what is a proper amount is "another story" at this time.

It is to be remarked here that it is very hard to over-emphasize the fact that a fertilizer should be applied weakly if possible, but often. To be applied often it must be weak or more than is necessary will be carried to the soil and either be wasted or worse. As a rule manure-water is such a weak liquid. It is certain that plant roots can grab what they want from an infinitely weak solution.

The accompanying table is an attempt to put part of this watering problem into figures. The peculiar way the values in the last column run is due to the employment of whole figures in the first.

One gal. applied to	1000 sq. ft. would get	Water would be
1 sq. ft.	1000 gallons.....	1.6 Inches deep
2 " "	500 "8 " "
3 " "	333 "5 " "
4 " "	250 "4 " "
5 " "	200 "3 " "
6 " "	166 "27 " "
7 " "	143 "23 " "
8 " "	125 "20 " "
9 " "	111 "18 " "
10 " "	100 "16 " "
12 " "	83 "13 " "
14 " "	71 "11 " "
17 " "	60 "10 " "
20 " "	52 "08 " "
26 " "	40 "07 " "
51 " "	20 "03 " "

A depth of water one fifth of an inch is not uncommon but the range varies so in practice that no one figure could be said to be "it." A whole raft of books could be written on this one subject.

Rudley M. Bray

NEWS OF THE CLUBS AND SOCIETIES.

GARDENERS' AND FLORISTS' CLUB OF BOSTON.

The next regular monthly meeting of the club will be held at Horticultural Hall, on Tuesday evening, January 21, 1908, at 8 o'clock.

The officers elected at the November meeting will be installed. In place of a regular lecture the meeting will be an open one to which ladies are particularly invited. A very pleasing entertainment has been prepared and other attractions will be added which will render this a most delightful gathering for all who attend.

The February meeting will be Carnation night, which will be a record breaker. Exhibits of all the season's novelties and other attractions are being prepared. Plans for the March meeting are also well under way.

The opening of 1908 finds the Gardeners' and Florists' Club of Boston more prosperous than ever before in its history. The officers for the present year will strive with might and main to make the club a power for good, and to keep it in the van of horticultural progress. No gardener or florist who wants to be up-to-date can well afford to remain outside our fold. May the new year be one of happiness and prosperity to all our members.

W. N. CRAIG,
Secretary.

ST. LOUIS FLORIST CLUB.

The St. Louis Florist Club made a good beginning in the New Year, which was very pleasing to President Young. The first meeting in 1908 took place on Thursday, January 9th, at 2 o'clock, with thirty members present. The entertainment committee reported in favor of economy and was granted further time until the next meeting. The proposed pottery stock company was reported on by the committee in charge. The report was quite lengthy and a long discussion took place. It was finally voted that a subscription list be floated for stock, and that this subscription be in the hands of the committee until May 15th, and unless by that time \$10,000 is subscribed the proposition will be dropped.

It was voted that the club hold its annual Carnation exhibition at the regular meeting in February, competition to be open to local growers only, and to invite growers of new varieties to send exhibition blooms for the benefit of our carnation growers, who are always well represented at these meetings.

J. E. Ammann of Edwardsville and A. S. Halsted of Belleville invited the members to come to Springfield February 18th to attend the meeting of the Illinois State Florists' Association, and promised them a good time.

The question box brought out a lively discussion on a number of important questions. This ended the first meeting of the Florist Club in 1908. February 12th is the date of the next meeting.

NEWPORT HORTICULTURAL SOCIETY.

The annual ball of the Newport Horticultural Society took place on Wednesday, Jan. 8th, in Masonic Hall. The attendance was large and the enjoyment was unabated from the start till the "Wee sma' hours" in the morning. The hall was tastefully decorated by the committee assisted by another committee from the Telephone Exchange, the employes of which had a ball there the evening previous. The committee, of which Mr. John T. Allan the president of the Horticultural Society was chairman, deserve great credit for bringing this ball to such a satisfactory conclusion, financial and otherwise. Although at no time uncomfortably crowded the hall was full from beginning almost to the end with active participants in the pleasures of the dance. A few, of course, looked on or chatted in corners but they were few in comparison with the number so engaged on former occasions.

D. M.

PASADENA GARDENERS' ASSOCIATION.

The regular meeting of the above association was held on January 3, President John Blake in the chair. There was a large attendance of members and also visitors from Los Angeles. A general discussion on roses and various topics took place. At the close Mr. Nilsson addressed President Blake and presented him with a gold and marble clock and pair of gold candlesticks to match as a mark of the appreciation of the good work done by him and his untiring endeavors in the interests of the association. Nineteen hundred and seven was a very successful year, each meeting being well attended, and at the present time there are 102 members in good standing and a neat sum in the bank in reserve for the next flower show. Officers elected at the December meeting were: President, John Blake; vice-president, Otto Hentchy; secretary, R. Mackenzie; treasurer, G. F. Nilsson; trustees, Howard Coolidge, J. M. Ross.

H. E. GEORGE.

THE CARNATION MEETING AT WASHINGTON.

The all-absorbing topic of conversation in the Washington florist world is the approaching carnation show to be held Jan. 28th to 30th inclusive, at National Rifles Armory. The banquet to be given on the evening of the 29th will be held at Kauscher's. There was a special meeting of the executive committee of the local club called on January 19th to dispose of some final matters, and the following gentlemen were appointed on the banquet committee, Peter Bisset, Geo. Cooke, Geo. Shaffer, John Robertson, Wm. F. Gude, F. H. Kramer and Chas. McCauley. With such an efficient committee there should be plenty of good things coming.

CONNECTICUT HORTICULTURAL SOCIETY.

This society held its regular meeting on January 10, President Huss occupying the chair. The newly appointed officers were duly installed and a program of the work for the coming year was outlined. Various committees were appointed and it was decided to hold a pansy show sometime during May. As we have a number of pansy enthusiasts in our community the success of the coming show is practically assured. As an indication that the exhibition will be on a considerable scale, John Gerard, the pansy specialist of New Britain, promises at least 2,500 pots from his district. President Huss exhibited for the first time here the new *Moschosma riparium*, which promises to be of considerable value as a winter flowering subject. It was awarded a certificate of merit.

Certificates of merit were also awarded to Mr. Huss for a fine display of cut orchids and a specimen plant of *Reinwardtia trigrinum*, and to A. J. Weber, gardener to Walter Goodwin, for *Nephrolepis Whitmanii*. President Huss presented the society with a block and gavel made from the Washington elm, which until within a few years was one of the famous landmarks of Hartford.

A. CUMMING, Jr.,
Secretary.

AMERICAN ROSE SOCIETY.

The Executive Committee of the American Rose Society met at the Hotel Martinique, New York City, on Monday afternoon, January 13. August Poehlmann of Morton Grove, Ill., has been appointed special committee-man for the Chicago Show. J. A. Valentine will present a paper at the annual meeting, upon Roses in Colorado; Adolph Poehlmann will present one upon Practical Rose Growing, and Wm. H. Elliott of Brighton, Mass., will give a paper upon the Proper Size of a Greenhouse for Commercial Rose Growing. Mr. Elliott has the largest single rose house in New England. Robert Craig of Philadelphia will have a paper upon Forcing Roses in Pots for Easter. A new rose from Sharon Hill, Pa., Mrs. Jardine, will be one of the novelties on exhibition.

The following judges have been appointed: Messrs. J. E. Wilcox, Council Bluffs, Ia., Adam Graham, Cleveland, O., and John H. Dunlop, Parkdale, Ont.

The Secretary reported that many of the members had paid up their annual subscriptions within ten days from mailing the bills, and that the Society needed as many as a thousand annual members, all interested. The details of schedules had been attended to and the first edition had already been printed and mailed. There will be a supplementary list of prizes issued to cover those that are given for special objects.

BENJAMIN HAMMOND, Secretary.

SOCIETY OF AMERICAN FLORISTS AND ORNAMENTAL HORTICULTURISTS.

Secretary Rudd announces the following appointments by President Traendly for the year 1908:

Entomologist—Prof. Frederick L. Washburn, University of Minn., Minneapolis, Minn.

Botanist—Prof. L. H. Pommel, Ames, Iowa.

Pathologist—Dr. B. M. Duggar, Columbia, Mo.

Legislative committee: Benjamin Hammond, Fishkill-on-Hudson, N. Y.; L. B. Coddington, Murray Hill, N. J.; Wesley Greene, Des Moines, Ia.; E. A. Moseley, Washington, D. C.; Patrick Welch, Boston, Mass.

State Vice-Presidents.

Alabama—H. F. P. Davis, Mobile, Ala. California—Sidney Clack, Menlo Park, Cal. Colorado—Emil Glauber, Montclair, Cal. Connecticut—Alex. Cumming, 188 Hawthorn street, Hartford, Conn. District of Columbia—Geo. H. Cooke, Conn. avenue and L street, Washington, D. C. Florida—E. N. Reasoner, Oneco, Fla. Georgia—M. C. Pennoek, Gainsville, Ga. Illinois—J. F. Ammann, Edwardsville, Ill. and Fred Lautenschlager, 2561 N. 41st St. Court, Chicago, Ill. Indiana—John Bertermann, 241 Massachusetts Ave., Indianapolis, Ind. Iowa—J. A. Kramer, Cedar Rapids, Ia. Kansas—Oscar Roehr, 1425 Fillmore street, Topeka, Kan. Kentucky—A. R. Baumer, 644 Fourth Ave, Louisville, Ky. Louisiana—U. J. Virgin, 838 Canal street, New Orleans, La. Maryland—R. A. Vincent, White Marsh, Md. Massachusetts—F. E. Palmer, Brookline, Mass. and A. J. Loveless, Lenox, Mass. Minnesota—C. N. Ruedlinger, 2924 Aldrich Ave., Minneapolis, Minn. Mississippi—S. W. Crowell, Rich, Miss. Missouri—J. Steidle, Central, Mo., and W. L. Rock, 1116 Walnut street, Kansas City, Mo. Nebraska—Lewis Henderson, 1519 Farnum street, Omaha, Neb. New Hampshire—B. Chase, Derry, N. H. New Jersey—A. Herrington, Madison, N. J. New York—G. C. Perkins, Newark, N. Y., and J. Austin Shaw, Box 545, New York, N. Y. N. Carolina—W. Rehder, Wilmington, N. C. Ohio—E. G. Gillett, 113 E. 3rd street, Cincinnati, O., and C. J. Graham, 2849 Euclid Ave., Cleveland, O. Pennsylvania—E. J. Fancourt, 1612-18 Ludlow street, Philadelphia, Pa. and T. P. Langhans, 504 Liberty street, Pittsburgh, Pa. Rhode Island—Carl Jurgens, Newport, R. I. S. Carolina—F. W. Wessels, Aiken, S. C. S. Dakota—E. C. Newbury, Mitchell, S. D. Tennessee—C. L. Baum, Knoxville, Tenn. Texas—E. H. R. Green, Dallas, Tex. Virginia—J. J. Curran, Salem, Va. W. Virginia—C. P. Dudley, Parkersburg, W. Va. Wisconsin—C. C. Pollworth, 54 City Hall Sq., Milwaukee, Wis., and E. Amerpohl, 214 S. Main street, Janesville, Wis. Ontario—T. W. Duggan, Brampton, Ont. Manitoba—H. E. Philpott, Winnipeg, Man.

THE NEW S. A. F. DIRECTORS.



GEORGE ASMUS,
Of Chicago.



JOHN YOUNG,
Of New York City.

PITTSBURGH FLORISTS' AND GARDENERS' CLUB.

The meeting of the club, January 7th, was Rose Night. E. G. Hill Co. had a large display of Rhea Reid and Princess, the latter a fine, light pink; also carnations Sarah Hill, white, Afterglow and White Enchantress. Princess rose may be renamed, as it seems the name has already been appropriated. It is said to be a good keeper and to open entirely out without dropping its petals. W. P. Craig showed rose Mrs. Jardine and Poehlmann Bros. Co. displayed Mrs. Potter Palmer. The president appointed as committee to pass upon the merits of the carnations exhibited, Messrs. Bader, Lorch and Crall, who awarded to the E. G. Hill Co. first-class certificates for carnations Sarah Hill and Afterglow, and certificate of merit for White Enchantress on its pure white color. Messrs. Fred Burki, T. P. Langhans and E. J. McCallum, as rose committee, awarded first-class certificates to E. G. Hill Co. for Rhea Reid and Princess; to Poehlmann Bros. Co., for Mrs. Potter Palmer, and to W. P. Craig, for Mrs. Jardine.

Fred Burki, Gibsonia, Pa., showed roses, among them being Alice Roosevelt, a sport from Chateauy, of which he has not yet grown enough to pass final judgment upon.

Henry Menschke showed roses, including Gen. MacArthur, the latter particularly noticeable for its charming fragrance. Dr. Shafer, through Jas. Hutchinson, showed four hybrid cypripediums.

The secretary was instructed to write to the American Carnation Society, inviting them to hold their 1909 meeting in Pittsburgh.

As officers of the club for 1908 the following were put in nomination: F. Burki, president; E. C. Reineman, vice-president; H. L. Blind, treasurer; H. P. Joslin, secretary; E. C. Ludwig, assistant secretary; P. S. Randolph, Jno. Bader and C. S. Crall, executive committee.

Jno. W. Jones, who has been president of the club for two years, declined a re-nomination. His faithful

services and hard work have been greatly appreciated by the club.

At the next meeting, on February 4th, there will be a competitive exhibition of carnations by members. As a committee in the interests of the commercial growers Messrs. Randolph and Burki are appointed. The committee for the private gardens will be named later by President Jones by mail. Committee on prizes, Messrs. Falconer and Langhans.

H. A. Bunyard, who was present at the meeting, after paying an eloquent tribute to private gardeners, offered in behalf of A. T. Boddington, a prize of \$10 for the best 50 blooms of carnations, solid color or mixed, open to private gardeners only.

Letter was read from the city passenger agent of the B. & O., quoting rate of \$10.70, round trip, Pittsburgh to Washington, D. C., and return, to attend the Carnation Convention.

H. P. JOSLIN, Sec.

NEW BEDFORD HORTICULTURAL SOCIETY.

At the annual meeting of the New Bedford Horticultural Society the following officers were elected:

President, Frank C. Barrows; vice-president, H. A. Jahn; secretary, Joseph C. Forbes; assistant secretary, Edward E. Shaw; treasurer, Walter A. Luce; executive committee, William Keith, Andrew J. Fish, John H. Lowe, Robert Dunn, Walter D. Hathaway, Arthur J. Brooks, Peter Priaux, William H. Gibbs.

It was voted to hold the flower show in the fall, probably in September.

PENNSYLVANIA HORTICULTURAL SOCIETY.

J. Otto Thilow will give his complete lecture with stereopticon views on the Yellowstone Park before the Philadelphia Horticultural Society next Tuesday evening, January 21st. Members of the Florists' Club with their ladies, and all others interested, are cordially invited. Mr. Thilow delivered only about one half of his lecture last August on account of lack of time.

AMERICAN CARNATION SOCIETY.

Carnation Registered.

By Henry Nichols, Waynesboro, Pa. Mrs. E. T. Omwake, a light pink sport of Enchantress, registered subject to the approval of the Society.

ALBERT M. HERR, Lancaster, Pa.

NEW YORK FLORISTS' CLUB.

The January meeting of this organization was devoted to the pleasant duty of installing the various officers, committee reports and consideration of policies for the incoming year. The retiring president, C. H. Totty, introduced his successor, C. B. Weathered, who was received with prolonged applause. The new president said that he had no new policy or plans other than to carry forward the purposes of his predecessors and to complete as far as possible any unfinished work. He hoped that the dream of many years of having a permanent home might be realized. With better meeting rooms, seventy-five per cent. of the membership might be brought regularly to the sessions. He referred with much satisfaction to the present financial strength of the club and advised economy in the entertainment committee's domain during the year to come. The negotiations now under way to bring about closer relations with the Horticultural Society of New York would establish a means for inaugurating periodical floral exhibitions in New York on a reliable basis, and he hoped that some mutually acceptable scheme of co-operation might be effected. The address was thoughtful and broad in conception and was very favorably commented upon.

Vice-president W. E. Marshall, escorted by John Birnie and Patrick O'Mara, was next presented. He endorsed all that the president had favored. Secretary John Young, who was then called upon, was reminiscent and congratulatory in his remarks and urged active co-operation of the membership in support of the president. The treasurer, J. K. Allen, briefly promised to do his duty; trustee E. V. Hallock declared his greatest hope to be that he would not disappoint his fellow members; trustee W. B. DuRoi said that it looked to him as though something was going to be done; the club had been organized for work and the time had come when they proposed to do it; and A. J. Rickards, who was jauntily escorted to the platform by Mr. "Bobbie" Schultz, spoke in a similarly enthusiastic strain.

Patrick O'Mara spoke for the committee on closer relations with the Horticultural Society of New York, going quite fully into the question of the benefits to New York horticulture which would accrue from a friendly co-operation of the two bodies, especially in the giving of public exhibitions. He explained that there was no intent to merge the bodies or interfere with the autonomy of either. The discussion which followed was quite animated, and the committee was given another month in which to deliberate.

The treasurer's report was presented by Mr. Sheridan, showing the comfortable sum of \$2,601.95 in bank. A communication from the B & O. R. R. was read, stating that round trip tickets on certificate plan from New York to the carnation meeting at Washington would cost \$7.55. Tickets good going from January 21 to 29 inclusive, and to return up to February 1.

Several members of the executive committee of the American Rose Society who had held a special meeting in the afternoon were present. President Robert Simpson spoke of the rose meeting to be held at Chicago in

March. He said that it was expected that the exhibition on that occasion would be the best in American rose history, and he hoped that a large representation of eastern growers would be present. The executive committee, he added, had accepted an invitation from the Horticultural Society of New York to hold a co-operative exhibition of roses in New York next June. Messrs. W. P. Craig, A. Farenwald and S. S. Skidelsky also spoke briefly on being called up.

A set of resolutions on the death of P. J. Hauswirth of Chicago, expressing sorrow at the loss of a valued friend and sympathy with his family, was adopted by a unanimous vote.

The question of the annual dinner of the club was next tackled and was productive of much fun, all the wits of the meeting contributing to the comedy of the occasion as they gave their views on the conduct and the price of club banquets. The upshot was a vote to adhere to time-honored traditions and have a course dinner.

The president announced the following standing and special committees: On death of Victor S. Dorval, Messrs. Donaldson, Shaw and Stewart; legislative, Messrs. O'Mara, Sheridan and Stewart; essays, Messrs. Birnie, Barron and Hammond; awards, Messrs. Totty, Simpson, Turner, Kennedy, Traendly, Zangen and Zeller; exhibition, Messrs. J. Manda, Jaenecke, Lenker, Butterfield and Nugent; dinner, Messrs. Sheridan, Craw, Henshaw, Schultz and Marshall; house, Messrs. Rickards, Weston and Burnett; new meeting room, Messrs. Young, Sheridan and Allen; outing, Messrs. Marshall, Schenck, Shaw, J. Manda, Weber, Adams, Reimels, Schultz, L. Schmutz, Jr., F. A. Lord.

On the exhibition table was a large vase of the new rose Mrs. Jardine; some fine sweet peas in bright colors from A. Zvolanek, and a seedling carnation from J. Lappe. The award of a certificate of merit for Mrs. Jardine was confirmed and votes of thanks were tendered for the other exhibits.

NEW YORK STATE FRUIT GROWERS.

The eastern fruit growers are not particularly interested in the work of Luther Burbank, the California hybridizer. J. R. Cornell, president of the New York State Fruit Growers' Association, which convened in Syracuse, Jan. 8-9, when asked for his opinions of Burbank's work, said:

"Oh, the eastern fruiters are not particularly interested in what he is doing further than to follow the reports of his work. We are willing to accept what he may do if he really does something which will be of general benefit. Freak combinations and productions are not of much use to the fruiter.

"Burbank has gotten a whole lot of free advertising and that's about the sum and substance of his work. Hybridizing is not a new thing, by any means, and long before Burbank was thought of it was used successfully. To cross and recross products of fruit trees and vines, to improve them in point of size or flavor or output has gone on from time immemorial, almost. The hybridizer of flowers or plants, you know, is a well-known

factor in the production of improved varieties.

"As a hybridizer, Mr. Burbank has been successful, I imagine." The Burbank potato is one of his chief points of distinction, but he did not create that. It bears his name, however. Anyhow, it cannot be said that the Burbank potato is the best in the market. There are others just as good.

"The spineless cactus is something about which the fruit grower of the east has nothing to do, and whatever success Mr. Burbank has achieved in that direction does not appeal to us, save as the natural curiosity aroused by any attempt of a similar character."

The addresses given during the two days' sessions were all of a high order, practical and instructive. The exhibit was good, a large display being on the tables. The State Experiment Station showed 184 varieties.

The newly-elected officers are: President, J. R. Cornell, Newburgh; 1st vice-president, S. W. Smith, Albion; 2d vice-president, D. D. Stone, Oswego; 3rd vice-president, H. L. Brown, Carlton; 4th vice-president, W. S. Page, Linden; secretary, E. C. Gillette, Penn Yan; treasurer, C. H. Damon, Geneva; executive committee, B. J. Case,odus, chairman; S. W. Wadhams, Clarkson; L. L. Morrell, Kinderhook; T. B. Wilson, Halls Corners; F. M. Bradley, Barker.

NASSAU COUNTY HORTICULTURAL SOCIETY.

This society held its monthly meeting at Glen Cove, L. I., on January 8, with a large attendance. H. F. Meyer showed a fine vase of carnations. The annual dinner of the society will be held at the Oriental Hotel, Glen Cove, on January 29, at 4 P. M.

GEORGE M. KURZ, Cor. Sec.

CLUB AND SOCIETY NOTES.

The Texas State Horticultural Society and the Nut Growers' Association met in joint session at Audleue on January 15 and 16.

The New Jersey Floricultural Society will hold their annual smoker, Friday, Feb. 7, at Elks Hall, 240 Main street, Orange, N. J.

Wilfrid Wheeler of Concord, Mass., was the speaker at the lecture of the Massachusetts Horticultural Society on January 11, and his story of the Concord grape and its originator, Ephraim Wales Bull, was very interesting. The Concord grape was first exhibited on Sept. 3, 1853, before the Massachusetts Horticultural Society, and it won at various times for Mr. Bull the society's silver medal and the gold medal.

There will be a meeting of the National Council of Horticulture at the Auditorium Annex, Chicago, Ill., at 10 A. M., Jan. 22, 1908. The members of the Council invite suggestions or questions on any topics which should properly come before that body. Plans for the press bureau service for the coming year must be worked out. It is hoped to make this a stronger feature than ever before. Other matters have been mentioned and it is hoped that other lines of work may be instituted which will be helpful to the horticultural interests of the country.

COMPETITION—FAIR AND FOUL.

Read before the Florists' Club of Philadelphia January 7th, 1908, by S. S. Skidelsky.

Competition, it is claimed, is the life of trade—and so perhaps it is, providing of course the "live and let live" principle is not lost sight of.

It is an axiomatic truth—and we are beginning to realize it, to some extent at least, that success in its broader sense hinges not upon the failure of others but upon the general welfare and prosperity of the community.

The idea that one man's failure constitutes another man's success or vice versa, as we have been led to believe by those whose vision is circumscribed by the ramifications of their pocket books, has long since been relegated, in theory at least, to the rubbish heap of similar fallacies, having no foundation in fact.

The infamous financier, for example, who attempted to corner the gold market and succeeded in plunging the country into a panic, was no more of a success in life than the savage in the jungle who strangles his antagonist in order to possess himself of a few brass trinkets. Both are dismal failures, notwithstanding the apparent ascendancy of might over right.

The progressive business man of today is inclined to take a more rational and a broader view of business conditions and business opportunities. It begins to dawn upon him that the fundamental principle underlying the success of any enterprise, great or small, must first of all be sound in itself, else no enterprise can possibly endure.

Go where we may and look where we choose—the signs of the times point clearly to a general awakening of public conscience, to a general revival of that Spirit of Justice which, since times immemorial and throughout the whole range of history—both ancient and modern—was never known to fail in its struggle for a worthy cause.

The Standard Oil Company, well nigh a kingdom and a law unto itself, the tobacco trust, the beef trust, and many another corporation of questionable repute, whose colossal fortunes were amassed at the expense of an indifferent and patient people—who defied public opinion and strangled competition by means that were foul and methods that were adverse to the public welfare—are called to account at last. Their day of reckoning seems to have come. A mighty avalanche of public opprobrium that has been gathering momentum for some time, bids fair to sweep down and hurl itself upon the heads of the malefactors with a force that will be crushing in its effect. "Fair play" and a "square deal" seem to be the cry of the hour.

We seem to realize at last that the "corrupt man of business"—to quote President Roosevelt—"is as great a foe to the country as the corrupt politician." We hear it also from the pulpit, at the bankers' banquet table, in the corner grocery store.

We seem to realize that the time has come to call a halt to iniquities, that God Almighty had never intended to concentrate all the privileges and all the opportunities in the hands of the few, that the world is broad enough for all willing to try their chances in it.

It is claimed—and not without good reason, perhaps—that the wave of materialism which has swept our country is gradually expending its force and that the succeeding generation will witness a complete transformation in our ideals and in our moral make-up.

Be that as it may, the fact is patent that our tendencies and aspirations are still steeped in the mire of greed, that we are still resembling our brothers in the jungle, one arrayed against the other, the strong preying upon the weak, the mighty crushing the small fry.

That green monster—Jealousy—prompted by the inexorable dictator—the Almighty Dollar—does not only rule amidst us, but it rules us with an iron rod that, at times, and to many of us, is well nigh unbearable.

"Peace on earth and good will toward men" is a beautiful injunction, having the right ring to it—in Church, but no where else. In our daily intercourse with our fellow men, we cannot possibly be governed by such obsolete rules.

"Business is business" bears a more practical sound to our ears. It is our favorite slogan and, in our estimation, it is broad and powerful enough to cover up a multitude of sins.

It is not my object, however, to deal in platitudes, nor do I wish to assume the role of the preacher, whose business it is to exhort his audience.

The subject I have chosen for my paper need not necessarily take me into labyrinth of figures and data in order to prove that two multiplied by two makes four. Nor need I depart far from my course in quest of examples in order to illustrate the striking contrast between the methods of fair and those of foul competition. Examples of either and both are at our very doors. We behold the one with a feeling of satisfaction and we become inspired with confidence in fellowman,—the sight of the other fills us with disgust and suspicion.

Fair competition courts the light of day. Having nothing to fear and nothing to conceal, it stands upon a pedestal of its own creation, firm and indestructible, in full view of an exacting multitude—being eager to prove and to convince, striving to achieve its success not by the circuitous way of fraud and deception, but by the straighter path of honorable means and honest business methods. Fair Competition believes in the "live and let live" principle. Having learned that lesson in its own school of Experience, it is eager to promulgate its truth to the world at large, fearing no detriment to its own interests, no ill results to its own pocket book. It is like an open book, accessible to all wishing to peruse its pages.

Fair Competition goes into the open market, firmly convinced that merit must and will win in the end, that success, if it is to be permanent, must rest not upon the quicksand of uncertainty, but upon a bed rock of stability.

It makes no rash promises, it shuns reckless statements, it abhors falsifications and adulterations of all sorts, ever aiming to improve rather than to cheapen quality, ever striving to win and to hold public confidence without which success is impossible.

Fair Competition does not cringe, does not fawn and does not sham—such despicable methods being foreign to its business policy. Nor does it concern itself with the affairs of its rivals for the purpose of ascertaining their methods in order to underbid and to undersell them.

If John sees fit to peddle his 4-inch geraniums at 60 or 75 cents per dozen, heralding that fact for months in advance in the "locals," with a view of cornering the geranium market and incidentally to put his rival out of business—it is John's own affair of course. Fair Competition does not attempt to follow his methods, much less to "go him one better," knowing full well that such prices do not cover the cost of production, let alone a living profit—realizing that by attempting to corner the market John will inevitably get into a tight corner himself, and it is seldom indeed that it errs in its judgment.

Fair Competition has mapped out its own way of doing things and it follows its own business methods. It reasons thus: All things being equal—the cost of production plus the cost of marketing the product, plus a legitimate profit—the price to the consumer must be clearly defined and based upon strict business lines, that any deviation from this straight business course, either one way or the other, must inevitably result either in a loss of confidence and custom, if the quality of the product be cheapened, else in financial ruin to the concern itself if quality be maintained at the expense of its legitimate profit.

A sense of propriety deters me from citing examples of concerns that have gone to the wall, because of such reasons, and of others that are heading that way by leaps and bounds.

Having arrived at this logical conclusion, Fair Competition becomes conscious of its own impregnable position. It has cast its anchor, as it were, in the harbor of safety, never fearing the assaults and calumnies of the numerous cheap Johns who would feign see a tidal wave engulf their successful competitor.

I doubt if any of the gentlemen present here will take exception to my assertion that foul competition is a curse to the business world.

Being utterly devoid of business or any other principles foul competition works on the assumption that there are fools—a plenty—eager to swallow the tempting bait—hook and all—called "Cheap."

Cheap! The very word has a sinister meaning if considered in its proper light. Cheap bulbs, like cheap clothes, yield but cheap results. Cheap plants come dear in the end; a cheap design, a floral monstrosity at so many nickels and dimes per foot—is a veritable sore to the eye, as well as an insult to the dead, and so all along the line.

Foul competition does not end here, however. There is a type of it, so low and degraded, so vile and treacherous, that the wonder is how any respectable and self-respecting business man can tolerate the moral stench of its very presence.

Conceived in iniquity and fostered in an atmosphere of fraud and corruption, unscrupulous, morally distorted, suave and cunning—foul competition has but one object in view

and that to attain its ignoble end regardless of means.

In its anxiety to grasp everything within sight, it is by no means content with the "purse" only, which the greatest poet of all times characterizes as "trash" and the slave of thousands. It goes a step or two farther, considering it good business tactics to reflect upon the name and the honor and to attack the reputation of a rival in business. It never occurs to these fellows that "he who steals my purse steals trash, but he that filches from me my good name robs me of that which not enriches him and makes me poor indeed."

Honor and justice mean empty sounds to their ears, and business ethics are an unknown quantity to them. They will not at all hesitate to tell you that the design or the decoration put up by Mr. Brown is not worth half the price paid for it, that the work is poor and that Mr. Brown is a foxy fellow anyway, one who will hear watching. On the road they will make it their business to sling dirt in every direction, in the hope of striking some competitor or other, leaving a trail of moral filth behind them that, to the fair minded man, is nauseating in the extreme.

They will pick up a plant of a rival concern and will pass judgment upon it there and then. In their estimation it is a very poor specimen indeed—the price paid for it being most unreasonable, of course.

New varieties of carnations lend themselves especially to attacks and to "knock-out blows," and these are often dealt without mercy.

"Don't touch it," you will hear them say, "it is a cropper, it has a weak constitution, it makes a measly growth, the calyx bursts, the blooms are ragged, the stem is short, and you had better leave it alone"—and all this assault without having the faintest idea of the true merit or faults of the variety in question.

If it be a batch of lily bulbs going or gone to the bad, as it often happens, here is a splendid opportunity to put in their ghoulish work. As a matter of course, the concern that supplied these bulbs is to be blamed for the poor results. The concern in question, they will tell you, is a back number anyway and is losing prestige and ground every day. In fact, there are all sorts of rumors. Has not somebody told him of somebody somewhere in Missouri or Connecticut who had a similar experience with lily bulbs bought of this very unreliable concern?

In fact Mr. So and So had the same trouble during the past few seasons "but now that he has our bulbs, you ought to see his lilies—perfect peaches and no mistake."

To be sure, men of this ilk soon show their true colors and, like all scamps, they will sooner or later defeat their own ends. Nevertheless, the mischief they create has, for the time being at least, a demoralizing effect upon an otherwise clear business horizon.

How to discourage such abominable practices, how to counteract such pernicious influences upon the trade are indeed vital questions that are well worth our while to consider seriously. If it be true, as somebody has

aptly put it, that "no shady transaction can stand the limelight of publicity," it may be worthy of our effort to turn on that light in its full force.

Says Dr. Torrey, the Evangelist: "A business man who says that every other business man is dishonest or a liar is a liar and a thief himself."

An evil that affects us all alike must not be ignored. A sneak at random, to say the least, is a troublesome creature indeed.

THE MASSACHUSETTS EXPERIMENT STATION.

Paper Read by Wm. P. Brooks, Director, at Massachusetts Conference of Rural Progress.

(Continued from page 860)

Hatch Experiment Station Established.

The Hatch Experiment Station was established under the provisions of an act of Congress applicable to all the states in 1887. It was named in honor of Senator Hatch of Missouri, the author, and chief promoter of the passage of the act bearing his name which provided for national support of agricultural experiment stations. By the provisions of this act the station must be a department of the college, and for this reason the money appropriated under the Hatch Act could not be placed at the disposal of the existing state station which as has been indicated was an independent institution. It did not seem expedient at that time to make the state station a department of the college and so arose the somewhat anomalous condition—two agricultural experiment stations side by side and practically in the same institution. Of the Hatch Experiment Station, President Henry Hill Goodell was made director, which position he held until his death in 1905. Under the organization adopted, it was arranged that all the chemical work required in connection with the experiments of the Hatch Station should be done in the State Station, which received for this work the sum of \$5000 annually, which was one-third of the appropriation from the national government. Throughout the period of the existence of the two stations, duplication of work was most carefully avoided and the harmonious relations existing between the two organizations and the members of their staffs were never in any way disturbed.

Two Stations Unite.

Nevertheless there soon came into existence a feeling that in the interest of economy of administration and work and for the best results the two stations should be united. This feeling strengthened with the passing years and in 1895 the union was effected by act of Legislature, the combined stations taking the name of the younger organization. My part as chronicler of station history makes necessary the mention of but one other change—the readoption of the name Massachusetts Agricultural instead of Hatch. When the latter name was taken, there already existed a Massachusetts station and to avoid confusion some entirely different designation was needed. It was suggested that it would be a graceful and appropriate act to honor Senator Hatch, the author of the bill under

which the stations were organized, by naming the new Massachusetts station after him. The reason for the name Hatch was never generally understood by the public and ludicrous blunders were a frequent occurrence. No other state designated its station "Hatch" though all were equally indebted to the Missouri senator. The uniform custom throughout the union has been to apply the name of the state to the experiment station; and therefore to bring Massachusetts into line and because the name of the state better characterizes the station the change was provided for by act of the most recent legislature and the last annual report and the last four bulletins bear the imprint Massachusetts Agricultural Experiment Station. With the consolidation of the original Massachusetts Agricultural Experiment Station with the Hatch Experiment Station Dr. Charles A. Goessmann who had been director of the former, was made honorary director of the combined stations. He continued in charge of the chemical fertilizer and fertilizer control work until last July when at the age of eighty he retired from active duties and was made expert consulting chemist. The present incumbent after acting in that capacity for a year was made the director early in the year 1906.

The policy put into practice with the organization of the Hatch Experiment Station of subdivision into distinct departments—with one exception under the headship of the professor at the head of the corresponding department of the college—is still followed. The head of the chemical department of the station is not directly connected with the educational work of the college. It is a question too broad and of too great importance to be entered upon in the limited time at our disposal whether in the best interests of station development and usefulness the policy of separate headship for college and station work along leading lines should not be more generally adopted.

Some of the Results.

Conscious as all those connected with station work have been and are that the ideals of the past even—to say nothing of the ideals of the present—have not been reached, a brief statement of some of our more important results must make it apparent that our work has touched and helped the farming public at many points. A complete summary of the work of the station is out of the question and cannot of course be looked for in an address of this character. Some statement of the results obtained, however, seems desirable and, though aware that injustice either in estimates of importance or through omissions will perhaps be done, is nevertheless presented in all modesty and sincerity.

Some of the things then that the farming public owes to the station are: better knowledge of methods of feeding our live stock whether for milk, pork, beef, mutton, veal, or eggs; far more definite information as to the nature and special adaptation of food stuffs; better knowledge of methods of feeding the crops of the field, garden and orchard; more accurate information as to the nature of manures and fertilizers and the results to be anticipated from their use under the

ever varying conditions of practical operations; far wider and more accurate knowledge of the insects injurious to crops and the discovery of much better means of destroying them; accurate knowledge of the nature and causes of many plant diseases and the perfection of methods of prevention; a clearer insight into the relations of environment to the development and health of crops which promises much in the direction of prevention of disease—that ounce worth so infinitely more than the pound of cure; the discovery of the causes operating to destroy or injure so many of our shade trees and the pointing out of methods of protection; and accurate reports as to the merits of new crops and new varieties.

Besides these and numerous other lines of work and discovery which might be mentioned, the station has tested and introduced to the agriculture of the country one crop—the Japanese barnyard millet—which has proved of enormous value throughout a large part of the United States. It is yearly grown upon thousands of acres and one enthusiastic seddman calls it "Billion dollar grass" because as he asserts, its general cultivation would increase our national wealth by that amount annually.

The station secured the passage of feed and dairy laws. It has helped to protect the public health by the analysis of well and spring waters. Finally and among the most warmly appreciated of its benefits, the members of the station staff have annually answered several thousands of letters of inquiry. This line of work, though possibly not the most productive in the direction of general advancement and uplift is nevertheless most highly appreciated by the man who seeks advice or who is in trouble and needs a remedy.

With this very incomplete reference to some of the accomplishments of the past, let us consider the present. Let me endeavor to show you what this engine of modern civilization known as the agricultural experiment station is, what it has to work with, and what it seeks to do.

What the Station Seeks to Do.

The experiment station is a department of the college. It numbers on its working staff twenty-one men, besides several clerks and stenographers. Of these men, thirteen give their entire time to the station; the others serve on the teaching force of the college as well. The organization of these men into divisions corresponding with the two great subdivisions in farming, viz., agriculture and horticulture, and with the leading sciences closely related to agriculture, chemistry, botany, entomology, veterinary science and meteorology, is natural and in the interests of efficiency. These divisions, while pursuing somewhat distinct lines of work, co-operate to the fullest extent the one with the other in all cases where circumstances require such co-operation for the best results.

The experiment station makes free use of such portions of the college estate as are needed in its various lines of work. Its buildings have been provided in most cases by direct and special appropriations from the state. It is supported by both state and national appropriations—about one-third of its

present assured income coming from the state and two-thirds from the national treasury.

The work of the experiment station is of three distinct classes: investigation, control work and dissemination of information. Though most important among the lines of station work and mentioned first, I shall speak of investigation last.

Control Work: The control work of the station has for its object the protection of the purchaser of fertilizers and feeds, and the user of certain classes of dairy apparatus. As related to fertilizers and feeds, the laws providing for this work require, briefly stated, that the seller "shall state what he sells and sell what he states." Those who remember the unsatisfactory character of the trade in fertilizers and feeds before the passage of these laws recognize their great value to the community. The honest manufacturer and dealer as well as the buyer being protected, the trade is infinitely more satisfactory and attains much larger proportions than before the passage of these beneficent laws. The execution of these laws is the province of the chemical division of the station, each being under the immediate supervision of a separate section. The financial support of the fertilizer control work is in part provided for by the license fees which dealers are required to pay, the balance coming from the general funds of the station. The feed and dairy control work is covered by a special state appropriation. These branches of our work employ almost the entire time of five chemists.

It seems desirable that in the near future the station should be charged also with seed control. The character of the seeds offered is now in many cases uncertain and unsatisfactory. They should be guaranteed both as regards genuineness, freedom from weed seed and foreign matter and percentage of germination.

Dissemination of Information.

Dissemination of Information: The station carries its information to the public through a number of distinct channels—most important among which are distribution of its publications, correspondence, object lessons and demonstrations, exhibits at fairs and farming special trains.

The station publications are the principal means of reaching the public. Since organization, the Massachusetts stations have issued 32 annual reports, 176 bulletins, besides a regular monthly meteorological bulletin and numerous circulars. These have treated a wide variety of subjects and have been given a very wide distribution. Our regular mailing list at the present time includes some 20,000 names, and to each address all regular bulletins will be sent.

The correspondence of the station has been previously referred to. During the farmers' busy season, the station will probably average 40 to 50 letters of inquiry daily. To answer many of these letters requires investigation or consultation of authorities, and this work makes a heavy draft upon the time of members of our staff. The work, however, is "present help in time of need," for every effort is made to return prompt replies—in

most cases the day of receipt of inquiry sees the reply dispatched. It is much appreciated, is rapidly growing, and unless it can be otherwise provided for, must be continued.

In the line of object lessons and demonstrations upon private farms in different localities and upon our own grounds, we have done something, but when resources in means and men permit, these lines of work may be much extended, for they surpass the printed page or the spoken word in clearness and strength of impression produced.

Farming special trains, of which we have operated one in co-operation with Vermont and New Hampshire, seem also to constitute a powerful agency for spreading information and driving home truths. These, however, are very expensive—a heavy tax both upon the treasury and the time and energies of busy men. Without the most generous co-operation of the railroads and a larger staff such trains are at present impossible.

Investigation.

Investigation: Experiments are suggested by the name adopted for this institution, and these are naturally regarded as its principal work, but that all experiments are not investigation is by no means always recognized. If, for example, the experiment station selects three supposedly similar and equal areas of land and having applied A's fertilizer to one, B's to another, and left the third unfertilized, then plants to corn, cares for the three areas similarly, harvests and determines which has given the better product, it has tried an experiment. So, too, if two lots of animals are fed in contrasted ways and the results compared, this is an experiment. In either case can the experiment be dignified by the title investigation. The results may have some value or, on the other hand, they may be absolutely misleading, so numerous and so variant are the conditions which in either case determine the outcome. To know that A's fertilizer in the case supposed gave a better crop than B's establishes a presumption perhaps that it is the better, but unless we have looked deeper and can give the reasons we have not made an investigation which deserves the name. The soil and the subsoil must be submitted both before and after cropping to close chemical and mechanical examination. The chemical character of the fertilizers must be exactly determined. The relations of climate to the outcome must be studied. The growth of the plants must be observed and recorded, and their composition determined. By such an investigation—the experiment being repeated until the result under known conditions can be foretold—the underlying causes and laws may be determined, and the discovery of these must have permanent value.

Up to the present time we have had perhaps too many experiments and too little investigation or research in the work of this as of other experiment stations. We are seeking to improve our work in this direction. Such improvement is in full line with our ambitions and is moreover both demanded by the most enlightened public sentiment and required under the last act of Congress relating to the station.

Seed Trade

Numerous interviews with prominent seedsmen during the past two weeks very happily confirm the optimistic opinions expressed in HORTICULTURE of January 4 as to the outlook for the seed trade for the coming year. As predicted in that issue monetary conditions have again become practically normal and this condition has come about more speedily than was expected. However, it is none the less welcome and removes whatever there might have been of doubt or misgiving for the near future, and leaves a prospect as promising as the trade has looked forward to in many years. Let us hope that this promise may bring a golden harvest.

The tendency to resort to arbitration as a means of settling disputes should appeal to seedsmen with commanding force, and particularly among themselves. Any serious litigation among them would be almost certain to reveal the skeleton in the closet, and it has been pertinently said, that however high or however low, every family has its skeleton. While many seedsmen may say there is nothing to conceal from the public, it is still a fact that there are many matters which but half explained as they would be in court, would certainly be of no benefit to the trade, but on the contrary from the fact that they are so imperfectly understood are liable to great distortion and exaggeration to the serious impairment of the seedsmen's prestige.

It seems to be quite generally understood that many efforts have been made by the American Seed Trade Association to establish a permanent board of arbitration to which all disputes between members as well as the trade in general who cared to avail themselves of its services could be referred for adjustment, but so far as the writer is able to ascertain, nothing practical has ever come of it. This is most unfortunate, as the value of such a board composed of say three or five of the most eminent members of the trade would command general confidence, and their decisions would be accepted in good faith by all honorable members. Of course such a body could not enforce its decisions, but it is assumed that those who resorted to it would pledge themselves to abide by its findings. The advantages of such a permanent board over the ordinary method of selecting arbitrators are many, not the least of which would be its really judicial character, and its findings would therefore be more in accordance with the facts than would be possible by the other method. Where each litigant selects an arbitrator, and these two select a third, the only unbiased man is this third party, as the other two are not arbitrators, but counsel for their respective clients, and regardless of facts or the merits of the case, each seeks to win the case for his client, and this is one reason why so many "arbitrated" cases are apparently so at variance with the facts.

The difficulties of forming such a board as has been described are recognized, but it is contended that if the seedsmen of the country appreciated its value and were earnest in their

advocacy of it, the thing could be done. The obstacles are not insurmountable, and always providing that the man who would most naturally be suggested would serve, the rest could be arranged. On such a board men of strong convictions and judicial temperament would be needed. The man of expediency who sits on the fence and gets down on the winning side would never do as an arbitrator, as his verdict would lead always in the direction of his personal interests. Developments of the near future may emphasize the necessity for such a body and cause regret that it does not now exist.

There is still some languid interest shown by canners in seed peas, particularly Admirals, of which there has not, and probably will not be enough to supply requirements, and this, despite the fact that nearly every grower has sold more or less of his seed of this variety. This fact will be noticed next year, and however large the crop from the acreage planted, there will almost certainly be a shortage in Admirals. This applies to all wrinkled varieties such as Advancers, Horsfords and Surprise, and we may as well include Alaskas, though there is less probability of a severe shortage in this variety, owing to more abundant seed stocks.

A few growers who started in to book future canners' peas at but slight if any advance over last year's prices, have seen a light and advanced their prices from 50 to 75 cents over last year's figures. In the meantime, however they have demoralized prices and caused considerable dissatisfaction among canners and no little resentment among the more conservative growers. The stupidity of these men has been commented on more than once, and it was remarked that they would doubtless continue such fool tactics as long as they live. Occasionally they are temporarily hoisted out of their rut by a few of the wiser growers, but easily revert again to their level, and the hoisting process must be renewed every year.

Preparations for the coming canners' convention go merrily on, and predictions are freely made that it will be the largest in point of attendance and machinery exhibits of any convention in the history of the canned goods trade. It is said that contrary to an agreement entered into by the hotel proprietors of Cincinnati and representatives of the canners, the former are raising their rates for the convention week. The agreement is said to have been verbal, and true to their reputation and characteristics the bonifaces are proceeding to violate it after preparations have progressed so far that no change to any other town is practicable. Hereafter agreements with these people or their colleagues in business should be in writing and signed with a forfeit attached.

In discussing the place for the next convention of the American Seed Trade Association with a number of members, Detroit seems to have the call, but what action the executive committee will take is not known even to the members themselves. It is not necessary to boom Detroit to those who know it, but it may be well to

MICHELL'S
SEEDS
Are Always Reliable.
1018 MARKET ST.
PHILA.
WHOLESALE CATALOGUE FREE

GLADIOLI

I can satisfactorily supply your wants for Gladioli for forcing or outdoor planting. Mixtures, color sections or named varieties of exceptional beauty.

Write for Prices

ARTHUR COWEE

Gladiolus Specialist

Meadowvale Farm, BERLIN, N. Y.

HYACINTHS, TULIPS, NARCISSI AND OTHER BULBS ROMAN HYACINTHS and the true PAPER WHITE GRANDIFLORA

Ask for our Wholesale Trade List at Hillegom

K. VELTHUYS, Hillegom, Holland
Rep by **FELIX BOSCH, 260 Jareidon St., Boston**

remark in passing, that a more beautiful city in June does not exist, with its many attractive and charming nearby resorts.

Heroic efforts have been made to save as much of last year's sugar corn crop as possible, and much of it has been dried artificially, but there is a woeful lack of vitality, and much that will be palmed off as seed might as well be pebbles as it will not grow 25 per cent. Whether price has yet reached high water mark or will go still higher, will be determined within the next thirty days. Unless it does go higher it will begin to decline before the canners' convention closes.

EUROPEAN CROP CONDITIONS.

The prospects of the winter crops in Europe are by no means so promising as they were a year ago. Yet the best possible condition of the seedlings in early winter gives no guaranty of ultimate success—last year's grain crops being a striking instance in point. A year ago full acreage had been sown and the crops had an adequate snow covering. But the ensuing severe winter and the late spring were beyond the endurance of a large proportion of the plants, and the harvest of winter grains was poor except in Great Britain, France, and Italy. This year generally late harvests and unsuitable weather in the autumn—excessive rain in western Europe and prolonged drought in eastern Europe—greatly delayed plowing and drilling. The lateness of the winter rendered possible

further seeding and a stronger development of the young plants than was thought possible a month or six weeks ago; but at the same time the consequent injury wrought by vermin and weeds has been large. Given the high range of prices so far this crop year, a large increase in the wheat acreage would seem inevitable; yet nowhere in Europe does it appear that such a result has been attained. The weather rendered it impracticable for farmers to carry out their plans in this respect. It is, indeed, improbable that the acreage of winter wheat is so large as last year. In parts of England and parts of France there has been some increase, but in both countries it is thought doubtful by most observers whether even as much land as last year has been sown to wheat. From Russia and the Balkan States come reports of greatly reduced acreage; and while the grain crops in the Balkan States have entered the winter in fairly safe condition, the Russian seedlings throughout the great winter wheat region, extending from the extreme southwest to the Caucasus, are in a precarious condition. In Hungary, as well as in the more southeastern countries, the plants are largely late sown

(Continued on page 72.)

BEGONIAS

Single Named colors	Doz.	100
" Mixed "	40c	\$2.50
Double Named "	35c	2.25
" Mixed "	65c	5.00
Gloxinias Named "	50c	4.00
" Mixed "	40c	2.50

WM. ELLIOTT & SONS
201 FULTON ST., NEW YORK

WIBOLTT'S SNOWBALL CAULIFLOWER SEED

is the earliest of all Snowballs, the most compact, the surest header, is giving the largest and snow-whitest heads, and is the best keeper in dry-weather. Demand it through your seed-firm or direct from

R. WIBOLTT, NAKSROY, DENMARK



Cyclamen
Superb English Strain
Second to none in size of flowers

Giant Crimson.
" Pink.
" White.
" White with Claret base.
" Mauve.
" Salmon Queen.
" New Fringed.

100 seeds \$1; 1000 seeds \$9.

H. E. FISKE SEED CO.
12 and 13 Fanuell Hall Square, - BOSTON MASS.

CAULIFLOWERS & CABBAGE

HJALMAR HARTMANN & CO.,
12 Stormgade,
COPENHAGEN, DENMARK.

ESTABLISHED 1802

Thorburn's Seeds

Send for our Wholesale Catalogue of Seeds for Florists and Market Gardeners, ready in a few days.

	Per doz.	Per 100
GLADIOLUS PRIMULINUS	\$8.00	\$60.00
PRIMULINUS HYBRIDS	3 00	20.00

J. M. THORBURN & CO.
33 Barclay St., through to 38 Park Place
NEW YORK
Everything of the Highest Grade

"QUALITY IS REMEMBERED LONG AFTER PRICE IS FORGOTTEN."
WHAT QUALITY MEANS.

Quality means the best and finest types procurable in their respective classes. We go to specialists for our flower seeds. Our customers, the Florist the private gardener demand the highest grade. We have no cheap catalogue trade. "Quality" may mean a little higher in price. "Quality" in fact means "Quality" and we know that when you buy from us you get it—and our customers know it too. Catalogue now in press; 40 pages. Write for one it's FREE. We sell bulbs too.

ARTHUR T BODDINGTON
SEEDSMEN
342 West 14th St., - - NEW YORK.

	Pkt.	Oz.
Agrotum Blue Perfection	\$0.15	\$0.50
Alyssum Little Gem . .	.10	.35
Ca dy Tuft Empress . .	.10	.20
Bellis Snowball25	
" Longfellow25	
Salvia Splendens25	1.35
" Bonlire25	2.50
Verbena Mammoth Mixed	.25	1.50

BRIDGEMAN'S SEED WAREHOUSE
RICKARDS BROS., Props.
37 East 19th St., NEW YORK CITY

BRASLAN SEED GROWERS CO.
GROWERS FOR THE
WHOLESALE TRADE ONLY
SAN JOSE, - - CALIFORNIA
Burpee's Seeds
PHILADELPHIA

Blue List of Wholesale Prices mailed only to those who plant for profit

BAMBOO CANES
They cost about 10 per cent. more than other kinds, and they are 10 times better.

STUMPP & WALTER CO., - 50 Barclay St., New York

RELIABLE SEEDS—SOW NOW

Alyssum Carpet Queen, real dwarf for pots only, no equal	Tr.	6 Tr.
Begonia Giracilis luminosa, new	Pkt.	Pkts.
Eriodia, beautiful	0.50	2.50
Lobelia, new Trading Hamburga	0.30	1.50
Petunia, Double Fringed Giants	1.00	5.00
" Single Fringed Giants	0.75	4.00
Phlox, best for pots, Fireball, Rose ball, Snowball, each color	0.25	1.25
Sativa Fireball, new, a fine potter	0.50	2.50
Stocks German 6 weeks, Blood red, Lavender, Pink, Purple, White, each color	0.50	2.50
Verbena Mammoth, Pink, Purple, Scarlet, Striped, White, each	0.25	1.25

My New Price List Ready for the Asking
O. V. ZANCEN
Seedsman. HOBOKEN, N. J.

Best Quality Fall Bulbs

It is to your advantage to place your order early. Send us a list of your wants and we will quote you rock-bottom prices. Copy of our Florists' Bulb Catalogue will be sent upon request. Catalogues now ready.

VICK'S SUPERB PANSY SEED
All the best varieties in separate colors
VICK'S SUPERB MIXTURE
the best strain from all the leading named sorts
1-8 oz. 75c. 1-4 oz. \$1.50 Ounce \$5.00
JAMES VICK'S SONS, Rochester, N. Y.

CYCLAMEN
Farquhar's Giant Strain

Unsurpassed for size of flowers.

Giant Crimson Giant Pink
Giant White Finest Mixed
Giant Excelsior, White with Claret Base
100 seeds, \$1.25; 1000 seeds, \$10.00.

R & J. FARQUHAR & CO.
6 & 7 So. Market St., Boston, Mass.

BRECK'S SEEDS
For Farmer, Market Gardener and Florist
New Crop High Grade
Catalogues mailed free on application
Joseph Breck & Sons Corp.
47-54 NO. MARKET ST., BOSTON, MASS.

JUST ARRIVED
LARGE SHIPMENT OF
High-Grade SCOTCH SOOT.
We have the Stott Double Nozzle
THOMAS J. GREY CO.
32 & 33 So. Market St., BOSTON

C. G. MORSE & CO.
Address all communications to our permanent address
48 to 56 Jackson St., San Francisco, Cal.
The Largest Seed Growers in the United States

TOUGH AND STRONG
6 ft. long - \$1 per 100; \$6 per 1000; \$11 per 2000
STUMPP & WALTER CO., - 50 Barclay St., New York

EUROPEAN CROP CONDITIONS.*(Continued from page 71)*

and are abnormally weak, and therefore particularly subject to damage from cold. While the greater part of Europe has experienced freezing temperature, snow is much less general than usual at this time of the year. Even in the face of the present gloomy outlook, however, it is by no means impossible that, if the seedlings are favored by a mild winter, a normal harvest of winter grain may be reaped in 1908.—From January report, Bureau of Statistics, Department of Agriculture.

MAINE VIEW ON FREE SEEDS.

To be sure it is not quite time to plant garden seeds up here in this part of Uncle Sam's big farm, despite the warm weather and the open winter, but down in Florida and just over in California the farmers and gardeners are putting in the early seed, and even in Washington the congressmen are getting ready for the usual supply to send to their constituents.

Of course congressmen must have their beet seed and turnip seed and so the House of Representatives has passed a deficiency appropriation bill setting aside \$50,000 for the purchase of more seeds for free distribution.

It was only last winter that Congress was busily engaged in talking about possible total abolition of the free seed graft. If memory is correct the movement even went so far that a committee report advised the abandonment of the wasteful appropriation for that purpose. Of course the reform was not successful. Moved by the touching appeals of men like Representative Chandler of Mississippi, who said that if no seeds were distributed by him his "dear old farmer friends" would look at him reproachfully and say: "You raised your own pay, but to us you are not willing to give even so much as a bushel basket of beans," Congress clung to the old idea of free seeds.

And now what do we discover? Not only has all the free seed money been spent, but more, too. It is going to take an extra \$50,000 to make up for the congressmen's overdrafts on their standing graft account.

The Commercial has steadily opposed this large annual draft on the treasury for free seeds. It has done so because in general the seeds sent out are of the old standard varieties which any one can purchase at all country stores for a few cents, and because in general many of the seeds are worthless.

It would be far better for Congress to make larger appropriations for the work of the several state experiment stations, and let the officials of the stations experiment with new seeds, find out what plants are adapted to the several states and ascertain what new varieties would be an acquisition to those we now have. In that way much good would come of the money so expended.

No appropriation for saving the White Mountain forests from destruction and for preventing the rivers from drying up; but thousands upon thousands of dollars for useless garden seeds. Such is congressional economy—or congressional graft. Down with it!—Bangor Commercial.

ORNAMENTAL HORTICULTURE.

Extract from a paper read before the Civic Club of Portland, Me., by Prof. Herman Beckenstrater.

The growth of any community along the lines of ornamental horticulture indicates progress along the lines of culture and refinement.

No doubt America is at the present time somewhat behind European countries in this line of work, but this is not strange, for long before the birth of our nation this art has had abroad a comparatively free field in which to advance. While in the pioneer century there was naturally a lack of means; today wealth, rapidly developing taste, and in fact everything needed for fostering the fine arts is with us, and the time is not far distant when we must excel in this as we do in most of the useful arts and inventions.

There is a general awakening all over the land. The larger cities have already developed large and extensive park systems and more land and money is continuously being appropriated to this cause and from the great amount of good that this is doing to the millions in the crowded cities many are asking why it was not done long ago. In large, populous centers the acquisition of land is becoming more and more difficult and expensive if not impossible, but in our smaller cities where land is still cheap, the city should not delay in acquiring parks and play grounds for the generations to come. It will never be easier and cheaper than now, and if any wishes to build a monument to his honor, I know of no better way than to donate a tract of land to his city for park purposes. Such a monument will be more enduring and beneficial to the future inhabitants than the endowment of a library or an institution of learning.

Where Charity Begins.

We are a missionary people—we are willing to spend millions for the conversion of supposed heathens in foreign lands, but we often forget that charity begins at home. There are millions of children and grown people in the crowded tenement houses in our large cities who never tasted the real pleasure of out-of-door life. Crimes of all kinds flourish in the crowded cities, and what else could we expect? There is nothing for the mind to do but brood over its own condition. Give them a chance to get acquainted with nature, with trees and flowers and a new vista of life will suddenly open up to them. To alleviate and better conditions like these is real missionary work.

Does Ornamental Horticulture pay? I would not cut down that tree for a hundred dollars, is an expression one may often hear from property owners, as they point to some favorite. And often the valuation is placed much higher than that. Now what did that tree cost? Perhaps \$5.00 fifteen years or so ago for the tree, preparing the soil and planting. From the time the roots took hold upon the soil and a beautiful show of foliage appeared increasing year by year in size, soon giving a pleasant shade, it has been a constant source of delight. Was the setting of that tree profitable considering the value at which it is now appraised and the pleasure it has afforded? The decisions of courts in this country have proven in more than

one instance that trees have property value and in many cases from \$50 to \$200 have been awarded for the destruction of a single shade tree.

The gains from ornamental horticulture cannot alone be computed in dollars and cents. It has been said that "The strength of America lies not in the roar of its cannon but in the cheerful fireside of its people." Whatever adorns one's home—be it in city or country—nobles his domestic life, strengthens his love for country nurtures the better elements of the natures in those who are thrown in contact with such improvement. To promote a love for trees, shrubs, vines and flowers by cultivating and studying them, develops in children a love for the beautiful in nature, in art and still more in character. Nothing is truer than that the love for nature sharpens the senses and quickens all the intellectual faculties. Were parents to provide to the fullest practical degree the simplest means for encouraging the love for ornamental gardening they early secure for the young a source of high enjoyment that is unknown elsewhere, one which elevates the mind and fills it with noble aspirations. Besides these things the mere spending of time on the part of all and especially of women and children in the exercise and enjoyment that comes from associating with and caring for plants is highly conducive to health.

Have a Plan.

A carefully prepared plan should precede all attempts in extended landscape gardening. It pays to do well whatever is done in landscape gardening. In starting such work it is too often undertaken without any thing like a definite plan. It would be quite as reasonable to work without a well considered plan in building our houses, yet we find that large sums of money in the aggregate are paid to architects for house plans while to the surrounding little thought is given to calling in the services of the trained gardener. When the day comes that the landscape gardener will be consulted along with the house architect in matters of home improvement, then a less sum of money will go farther to the purchase of real beauty, pleasure and comfort than when the latter is alone employed.

Time for Producing Effect.

There are many who would like to plant trees and shrubs but are kept from doing so by erroneous notions as to the time it will take to produce results. It is possible so to treat trees that they will not grow the same number of inches in 10 years; but on the other hand they may by proper management reach a height of from two to three times as many feet in 10 years from planting. The difference lies in matters that ordinarily are in a large degree without our control. When trees remain almost at a standstill for a long time it indicates either that they were of poor quality in the beginning or in rare cases that the soil cannot be fitted to their wants, but very commonly that they are deprived of the food and moisture they would appropriate if they had the chance.

It is well to know that as a rule shrubs come to maturity quicker than trees. Planted in good soil, these

NEW ROSE--MY MARYLAND

I am booking orders now for this new rose. It is a beautiful salmon pink with long buds. Easy and strong grower. Makes no blind wood, has averaged 22 flowers to a plant since the first of October, has long stiff stems. Some of the largest growers who have seen it have bought from one to three thousand plants.

PRICE, 2 1-2 inch pots, \$5 per dozen, \$25 per 100, \$200 per 1000.

STOCK LIMITED

JOHN COOK, 318 N. Charles St., Baltimore, Md.

GERANIUMS

WE have an immense crop of good plants from 2 inch pots, ready for immediate shipment at prices running from \$2.00 per 100 up for good standard sorts. We will send one thousand in twenty varieties, our selection, for \$18.50; five hundred for \$9.25.

ALLIANCE—A Hybrid between a Zonal and an Ivy and which has retained all the good points of both parents, the beautiful soft finish of an Ivy and the hardy constitution of the Zonal. Its color is the most exquisite shade of delicate lilac white, feathered and blotched crimson rose, flowers semi-double, habit dwarf, an ideal pot plant in every way. Strong plants from 2 inch pots, \$1.00 per doz., \$6.00 per 100.

IVY GERANIUMS—In good assortment, \$3.00 per 100. We make the special offer for a short time of \$25.00 per 1000, our selection of five kinds, 500 for \$12.50.

CACTUS GERANIUMS \$1.00 per doz., \$8.00 per 1000.

For **Dahlia Root** and Miscellaneous stock see issue of Dec. 28th. **Cash with order.**

R. VINCENT, Jr. & SONS CO., - White Marsh, Md.

take hold quickly and in a few years show beauty in habit, foliage and flowers that is scarcely excelled in after years, though they may increase in size. Planting is often delayed from year to year until sufficient time has passed to have allowed the trees to make large growth had they been set when the idea was first entertained. Almost any shrub or tree, with good treatment, may be counted on to reach a very pleasing size in from two to six years from planting. How soon such a period slips by! To illustrate permit me to cite the experience of the capitol city of my own native state. Outside of the Capitol and university grounds there were no public parks in Madison, Wisconsin, 15 years ago. Now there are 300 acres of parks connected by some 30 miles of beautiful parkways. While Madison is naturally a beautiful city, it contained besides beauty spots, many swampy and unsightly regions. Chief among these was the marshy region along a sluggish stream that connects the waters of the two lakes through the peninsula upon which the city is situated. This was a dumping ground for 50 years. It had become so ugly and unsightly that we used to shut our eyes as we passed in and out of the city on the trains. At last a crusade was started against it and this region was practically turned into a paradise of beauty during my college days. Another park which was nothing but a marsh less than 10 years ago was similarly transformed and is now one of the most delightful little parks in the entire Northwest.

It is well to bear in mind that "the way to get started is to start." To debate too long on pros and cons consumes energies without result. Do something and in the course of your

NOW READY Our 1908 Catalogue

CHRYSANthemUMS OUR SPECIALTY

The most comprehensive work of its kind in this country If not received by the 20th drop us a card.

Elmer D. Smith & Co.
Successors to NATHAN SMITH & SON
Adrian, Mich.

THE FINEST

Lily of the Valley Excellenta

From cold storage. Only few cases left. Please order at once. \$32.00 per case of 2000 fine pips.

JOHN SCHEEPERS & CO.
4 & 6 Old Slip, - - NEW YORK.

New Violet BOSTON

In introducing this new variety to the trade I wish to state that I have been growing it in quantity for the past two years and do not hesitate to state that it is entirely distinct, a strong grower, a free bloomer, and the finest single violet in cultivation. Ready for distribution in April and May. Orders booked now. \$2 per 12; \$12 per 100; \$100 per 1000. 500 at 1000 rate.

WILLIAM SIM, CLIFTONDALE, MASS.

ROBERT CRAIG CO.

ROSES, PALMS,

and Novelties in Decorative Plants

MARKET and 49th STREETS., PHILADELPHIA, PA.

activities allies will appear to assist by their council, means and other necessities.

ORCHIDS

Largest Importers, Exporters, Growers and Hybridists in the World

Sander, St. Albans, England
and 235 Broadway, Room 1
NEW YORK CITY

... ORCHIDS ...

Just to hand, C. Trianae, C. labiata, C. Mossiae, C. Intermedia, C. Schroderae, C. Speciosissima, C. Citrina, C. Gaskelliana, Laelia Anceps, L. Albida, L. majalis, L. Autumnalis, Epidendrum Vittelinum majus, E. Cooperianum, Oncidium Crisp m, O. Varicosum. O. Cavendishianum, O. Luridum, Odonto. Citrosium. To arrive in a short time, C. Dowiana, C. Aurea, C. Warnerii, Miltonia Vexillaria.
GARRILLO & BALDWIN SEGAUCUS, N. J.

ORCHIDS

Just arrived, in fine condition,
Cattleya Trianae (new district).
Oncidium Varicosum Rogersii.

Write for prices.
JOSEPH A. MANDA, 191 Valley Road,
WEST ORANGE, N. J.

Write at once for our quotations on all

ORCHID IMPORTATIONS

FOR 1908 DELIVERY

JULIUS ROEHRS CO.,
The Orchid Nurseries, Rutherford, N. J.

ORCHIDS

We are at present booking orders for freshly imported Orchids for delivery 1908, of all leading kinds at reduced prices. We have just received the following:—
'ncidium Sarcodes, O Forbesi, O Tigrinum and Sophronites, Brantiajlora and Coccinea.

LAGER & HURRELL, Summit, N. J.

ORCHIDS

The largest importation of Orchids ever received in this country **WILL ARRIVE** next spring from Brazil, Colombia and Venezuela. If you intend putting in stock **wait** for these to arrive and we will quote the **Lowest Prices in America.**

ORDONEZ BROS., - Madison, N. J.

In ordering goods please add, "I saw it in HORTICULTURE."

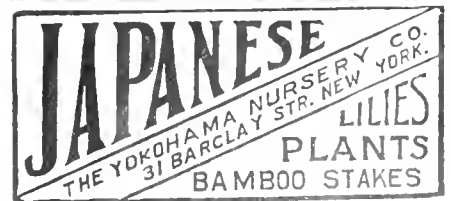

Obituary

Victor S. Dorval.

Another one of the old-time gardeners has gone. Victor S. Dorval, who died at his home in Woodside, Long Island, N. Y., on January 12, was born in Dijon, France, 75 years ago. He received his first horticultural training in the park of Boule d'Or in Dijon. Thence he went to the Barrillier Greenhouses of the City of Paris under La Meutte and then to Buenos Ayres as gardener to a priest who accompanied him from France. Shortly after he went into the sheep business, but the war broke out and he was left penniless. He came to the United States about 1870, and after occupying positions in Washington, Whitestone and Newport, finally settled in Woodside about 1874 and conducted a florist business until six years ago, when he retired, leaving the business to his two sons, Victor S. and Edward J. Besides these he leaves a widow and one daughter. Carnations, buibs and bedding plants were his specialty. He has furnished

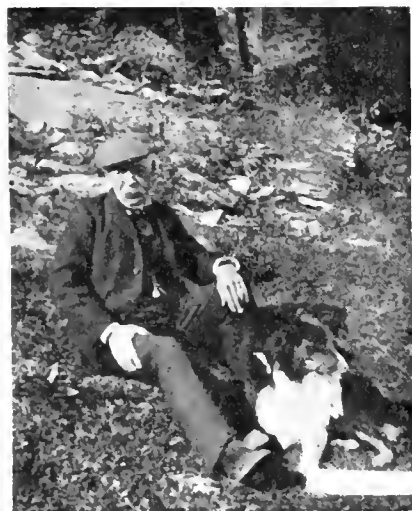

VICTOR S. DORVAL.

the Trinity Corporation with the latter every year since 1878. In addition to his Woodside establishment he had a fine place at Great Neck.

Mr. Dorval was a member of the New York Florists' Club, and until quite recently of the Society of American Florists. He was a congenial, open-hearted, lovable man, of sterling character, and will be mourned by a large circle of friends and neighbors. He has been in failing health since last summer.

Marston B. Bunker.

The sudden death of this well-known Boston florist comes as a great shock to the trade. As announced in our issue of last week, Mr. Bunker went, on Wednesday, to the Boothby Hospital, where he underwent a surgical operation on Saturday and from the effects of which he died on Sunday. Mr. Bunker was born in Cambridge, April 25, 1859. As a young man he entered the flower business in Boston, and for a number of years had charge of the flower stands at the Parker House, Young's Hotel and the Touraine. Later he opened a

EXTRA FINE BOXWOOD \$17.50 per CWT.
FANCY FERNS, A No. 1 Quality. \$1.50 per 1000
GREEN CALAX \$1 per 1000, \$7.50 per 10,000
BRILLIANT BRONZ \$1 per 1000, \$8.50 per 10,000

Headquarters for HARDY FERNS, MOSS, LAUREL, PRINCESS PINE, FESTOONING, Etc. See Our Cut Flower Ad.

HENRY M. ROBINSON & CO., FLORISTS' SUPPLIES 15 Province St., and 9 Chapman Pl., BOSTON

store in Beacon street and for the past nine years has been located in City Hall avenue, where he did a good business. He leaves a widow, son and daughter to mourn the loss of a devoted husband and father. The funeral took place on Wednesday, January 15, from his late residence in Somerville

Sol. D. La Rosh.

Sol D. La Rosh, one of the pioneer residents of Pekin, Ill., died on January 4, at the age of 67. Mr. La Rosh attained a state reputation for the quality and variety of fruit raised on his farm in Groveland township.

Fred Thayer.

Fred Thayer, at one time in the florist business at Westfield, Mass., was killed suddenly at N. Wilbraham on January 4.

Mrs. Lydia B. Manning.

Mrs. Lydia B., wife of the late Jacob W. Manning, of Reading, Mass., passed away on January 9.

NEWS NOTES.

Jacob Becker has added a new house, 22x186, to his already extensive range at 49th and Chestnut streets, Philadelphia. The old plant is being conducted as usual.

Robert Craig says that all *Dracaena terminalis* plants ought to be sponged over now with a mild solution of fir tree oil. Weak and unworthy plants are not worth their board bill.

Fire in the early morning of January 6 destroyed the main greenhouse at Ervin Hayden's, Marblehead, Mass., and his entire stock was ruined by the smoke and cold air. Loss, \$3000; no insurance.

Nathan D. Pierce, proprietor of the Norwood Floral and Home Nursery Companies, Norwood, R. I., has leased the Standard Greenhouses. This gives him an area of 20,000 square feet under glass which will be devoted to carnations and violets.

Frederick Law Olmsted and other experts are formulating plans for beautifying Baltimore's group of public buildings, along Fayette street and the market buildings on Center Market Place. It is proposed among other things to convert Jones' Falls into a covered stream and construct a boulevard along its entire length from Baltimore street to North Ave.

The State Commission on Industrial Education of Massachusetts have plans outlined for about twenty high schools of agriculture at convenient distances geographically and varied according to the needs of the sections in which

BOSTON FLORIST LETTER CO.
 Manufacturers of FLORISTS' LETTERS

This wooden box nicely stained and varnished, 18x30x12, made in two sections, one for each size letter, given away with first order of 500 letters

Block Letters, 1 1/2 or 2 inch size per 100, \$2.
 Script Letters, 3. Fastener with each letter or word. Used by leading florists everywhere and for sale by all wholesale florists and supply dealers

N. F. McCARTHY, Manager
 66 Pearl Street. BOSTON, MASS.

The "Japana" Cut Flower Holder

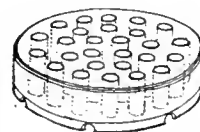

A handy article for florists. Sells to the trade on sight. Made of glass in three sizes. The "Anglais" Table Decoration, something entirely new, long needed. The florist and housewife will appreciate this article, as it simplifies the art of table decorating.

Ask for catalog.
M. V. CARNSEY, Dept. J,
 130 Waiola Ave., La Grange, Ill.

KORAL SCRIPT LETTERS AND EMBLEMS
ONCE USED ALWAYS USED
 For sale by all first class supply houses. Made by
KORAL MFG. CO.
 26 Hawley St., Boston

E. A. BEAVEN
Southern Wild Smilax, Log Mosses,
 Natural and Perpetuated — at Wholesale,
EVERGREEN, ALABAMA.

GALAX FROM FIRST HANDS

GALAX	}	Bronze, small to med. size.....	.35c 1000
		" " medium size.....	.40c 1000
		" " large size.....	.45c 1000
		Green, medium size.....	.40c 1000
		large size.....	.45c 1000

Terms: Strictly cash, f. o. b. Galax, Va.
W. M. WOODRUFF & SON, Lowgap, N. C.

they are located. Plant life from seed to harvest, entomology in so far as it relates to insect enemies, elementary forestry, horticulture in greenhouse and garden, are some of the special topics to be taught. A two years' or four years' course can be taken. Northampton is the only place that has availed itself of this privilege thus far.

**JOHN BREITMEYER'S
SONS**
Cor. Miami and Gratlot Aves.
DETROIT, MICH.
**Artistic Designs . . .
High Grade Cut Blooms**
We cover all Michigan points and good
sections of Ohio, Indiana and Canada

P. J. HAUSWIRTH
232 Michigan Ave.
CHICAGO
AUDITORIUM ANNEX Tel. Harrison 585
SAMUEL MURRAY
Florist
Coates House Conservatory
1017 BROADWAY, KANSAS CITY, MO
Both 'Phones 2670 Mafo

FRED C. WEBER
FLORIST
4326-28 ST. LOUIS, MO.
OLIVE STREET
Established 1873
Long Distance Phone Bell Lindell 676



**WASHINGTON,
D. C.**
GUDE'S
GUDE BROS CO
FLORISTS
1214 F ST NW
WASHINGTON DC

Geo. H. Cooke
FLORIST
Connecticut Avenue and L Street
WASHINGTON, D. C.

The Park Floral Co.
J. A. VALENTINE
Pres.
DENVER, COLORADO

WILLIAM L. ROCK
FLOWER CO.
KANSAS CITY, MO.
will carefully execute orders for Kansas City
and any town in Missouri or Kansas.

ALBANY, N. Y.
EYRES
Flowers or Design Work
DELIVERED IN ALBANY AND VICINITY
ON TELEGRAPHIC ORDER.
11 NORTH PEARL ST., ALBANY, N. Y.

NEWS NOTES.

At Newport, R. I. the wind completely demolished a greenhouse on the estate of Otto Ehrhardt.

High winds on January 7 did considerable damage to the greenhouse on the Winslow estate, North Beverly, Mass.

Poole & Purlant, having disposed of their business at Bellefontaine, have located at Washington Court House, O.

Schedules in bankruptcy of J. M. Hodgson, florist, of New York and Newport, show liabilities of \$26,460 and assets, \$7,524; 170 creditors.

An interesting talk on Italian gardens was given by J. K. M. L. Farquhar of Boston before the Worcester County Horticultural Society, Worcester, Mass., on January 9.

The recent accounts of experiments to force plants by use of electricity brings out the fact that Dr. Lyman Larkin of Wrentham, Mass., was a successful practitioner in that line nearly half a century ago.

C. S. Strout of Biddeford, Me., has received eight prizes on his carnations and chrysanthemms from the Massachusetts Horticultural Society. As they were the only prizes distributed in that state, Mr. Strout attaches great value to them.

BUSINESS CHANGES.

The Piedmont Floral Co. is now located at Hotel Athens, Broadway, Oakland, Calif.

R. S. McMurray has purchased the greenhouse business of Poole & Purlant, Bellefontaine, O.

Miss A. M. Browne and Mrs. B. O. Weisenger have bought the business of the Beaumont Floral Co., Beaumont, Tex.

LEADING RETAIL FLORISTS—
Index by Towns will be found in
Buyers' Directory.



Send flower orders for delivery in
BOSTON
and all
NEW ENGLAND POINTS
THOS. F. GALVIN
124 Tremont St., Boston

TRANSFER
Your orders for flower or plant delivery in
Eastern New England to
JULIUS A. ZINN,
2 Beacon St., Boston.
Fine Design Work a Specialty

ATLANTA FLORAL CO.
41 Peachtree Street, ATLANTA GEORGIA.

Florists Out of Town

Taking orders for delivery in
New York or Vicinity
can have them filled in best
manner and specially deliv-
ered by * * *
Thomas Young, Jr.
41 W. 28th St., New York City

ALEX. McCONNELL
571 FIFTH AVENUE
NEW YORK CITY
Telegraphic orders forwarded to any
part of the United States, Canada, and
all principal cities of Europe. Orders
transferred or intrusted by the trade to
our selection for delivery on steamships
or elsewhere receive special attention.
Telephone Calls, 487 and 488 38th St.
Cable Address, ALEXCONNELL

WILLIAM H. DONOHUE
FLORAL DECORATOR
17 East 28th St., New York
Special Attention to Theatre
and Steamer Orders, and reliable
deliveries guaranteed.

DAVID CLARKE'S SONS
Deliver orders from any part of the country to
New York City
Or OUT-GOING STEAMERS
Write or telegraph
2139-2141 Broadway, New York
Telephone 1552-1553 Columbus

**PROMPT DELIVERY IN
BOSTON**
AND ALL NEW ENGLAND POINTS
HOUGHTON & CLARK
396 Boylston St., Boston, Mass.

Flower Deliveries
In Brooklyn and other Long Island Points
New York City, New Jersey, etc. At Theatres,
Hotels, Steamers or Residences.

WILSON
Fulton St. and Greene Ave., Brooklyn, N.Y.

YOUNG & NUGENT
42 West 28 St., NEW YORK
"FLOWERS BY TELEGRAPH"

William J. Smyth
FLORIST
Cor. Michigan Ave. and 31st St., CHICAGO
We ship to all points in Illinois and Iowa.
Phones: Douglas 744, Douglas 523, Douglas 740

JACOB SCHULZ, 644 Fourth Ave.,
LOUISVILLE, KY.
Cut Flowers of BEST QUALITY in season
delivered promptly to any address.
Write, Telegraph or Telephone.
Cumberland and Home Phones 223 and 984

CARNATIONS — Rooted Cuttings

Healthy, well-rooted stock the product of the most reliable growers of this locality

	Per 100	Per 1000		Per 100	Per 1000		Per 100	Per 1000
White Enchantress, - - - -	\$6.00	\$50.00	Enchantress, - - - -	\$2.50	\$20.00	Harlowarden, - - - -	\$2.00	\$18.00
White Perfection, - - - -	3.00	25.00	Helen Goddard, - - - -	2.50	21.00	Patten, - - - -	2.50	20.00
White Lawson, - - - -	2.00	18.00	Lawson, - - - -	2.00	18.00	Fenn, - - - -	2.00	18.00
Queen Louise, - - - -	2.00	18.00	Heacon, - - - -	6.00	50.00	Red Sport, - - - -	2.10	18.00
Winsor, - - - -	4.00	30.00	Victory, - - - -	3.00	25.00	Boston Market, - - - -	2.00	18.00
Aristocrat, - - - -	6.00	50.00	Craig, - - - -	3.00	25.00	Joost, - - - -	2.00	18.00
Rose PK. Enchantress, - - - -	3.50	30.00						

NEW CROP SEEDS
ASPARAGUS PLUMOSUS NANUS \$4.50 per 1000.
 Special prices on large quantities. Greenhouse Grown, Hand Selected

MRS. JARDINE: the sensational new pink rose: 2½ inch
 pots; **\$30.00 per 100, \$250.00 per 1000**
 Orders Booked Now

S. S. PENNOCK-MEEHAN COMPANY, "THE" Wholesale Florists of
1608-1620 Ludlow Street, PHILADELPHIA

EVERYTHING SEASONABLE IN
CUT FLOWERS
EDWARD REID, Wholesale Florist
 1526 Ranstead St., PHILADELPHIA
 STORE CLOSES 8 P M.

CHAS. W. McKELLAR
 51 WABASH AVE., CHICAGO
 Western Headquarters for Choice Orchids
 Valley, Roses and all Cut Flowers

PETER REINBERG
 WHOLESALE
CUT FLOWERS
 51 Wabash Av., Chicago, Ill.
 In writing advertisers mention Horticulture

CUT FLOWER BOXES
EDWARDS FOLDING BOX CO
 MANUFACTURERS
 PHILADELPHIA, PA.

AMERICAN BEAUTY and all other ROSES
LILY OF THE VALLEY, CARNATIONS
WELCH BROS., 226 Devonshire St., Boston, Mass.

TRUMPET MAJORS
 Extra Quality Any Quantity
W. E. McKISSICK WHOLESALE FLORIST
 PHILADELPHIA
 1619-1621 RANSTEAD ST.

DAILY CONSIGNMENTS
 From 40 to 60 Growers
 We can care for your cutflower wants to advantage.
E. F. WINTERSON CO.
 45-47-49 WABASH AVE., CHICAGO

ROBERT J. DYSART,
 Public Accountant and Auditor
 Simple methods of correct accounting especially adapted for florists' use.
 Books Balanced and Adjusted
 Merchants Bank Building
28 STATE ST., BOSTON
 Telephone, Main 38

WHOLESALE FLOWER MARKETS
 TRADE PRICES—Per 100—TO DEALERS ONLY

	CHICAGO Jan. 15	TWIN CITIES Jan. 13	PHILA. Jan. 13	BOSTON Jan. 16
ROSES				
Am. Beauty, Fancy and Special... to 50.00	60.00 to 80.00	50.00 to 60.00	40.00 to 50.00
" " Extra	30.00 to 40.00	35.00 to 50.00	30.00 to 40.00	20.00 to 30.00
" " No. 1	15.00 to 25.00	20.00 to 30.00	15.00 to 20.00	10.00 to 15.00
" " Lower grades...	8.00 to 10.00	12.00 to 18.00	5.00 to 10.00	6.00 to 8.00
Bride, "Maid, Extra & Special	8.00 to 10.00	10.00 to 18.00	12.00 to 15.00	10.00 to 12.00
" " Extra	6.00 to 7.00	8.00 to 12.00	8.00 to 10.00	6.00 to 8.00
" " Lower grades	3.00 to 5.00	6.00 to	3.00 to 6.00	2.00 to 4.00
Killarney, Richmond, Fan & Sp...	8.00 to 15.00	8.00 to 12.00	15.00 to 25.00	12.00 to 25.00
" " Lower grades	6.00 to 7.00	4.00 to 6.00	5.00 to 8.00	4.00 to 6.00
Chateauy, Wellesley, Fan & Sp...	8.00 to 12.00	8.00 to 12.00	15.00 to 25.00	12.00 to 15.00
" " Lower grades	3.00 to 6.00	6.00 to 8.00	5.00 to 8.00	6.00 to 8.00
Golden Gate Ivory	5.00 to 8.00	10.00 to 15.00	4.00 to 12.00	6.00 to 8.00
CARNATIONS				
Fancy and Novelties	4.00 to 5.00	4.00 to 8.00	4.00 to 6.00	4.00 to 5.00
Ordinary	2.00 to 3.00	3.00 to 5.00	2.00 to 3.00	2.00 to 3.00
MISCELLANEOUS				
Violets	.75 to 1.00	1.00 to 1.50	.50 to 1.25	.50 to .75
Cattleyas	40.00 to 50.00	45.00 to 60.00	50.00 to 60.00	40.00 to 50.00
Cypripediums	12.00 to 17.00	15.00 to 20.00	12.50 to 15.00 to 12.00
Lilies	12.00 to 20.00	15.00 to 20.00	12.00 to 15.00 to 16.00
Lily of the Valley	3.00 to 5.00	3.00 to 5.00	2.00 to 5.00	2.00 to 4.00
Romye Hy., Paper White Nar...	2.00 to 3.00	2.00 to 3.00	2.00 to 4.00	1.00 to 2.00
Stevia	1.50 to 2.00	2.00 to 3.00	2.00 to	1.00 to 1.50
Mignonette	3.00 to 8.00	4.00 to 5.00	2.00 to 5.00	3.00 to 6.00
Acanthum	1.00 to 1.50	1.00 to 1.50	1.00 to 1.50	1.00 to 1.50
Whitmanii Fronds	.75 to 1.00	1.00 to 1.50	1.00 to 1.50	1.00 to 1.50
Smilax	15.00 to 25.00	4.00 to 5.00 to 4.00	1.00 to 2.00
Whitmanii Fronds	15.00 to 25.00	12.00 to 15.00	12.00 to 15.00	12.00 to 16.00
Asparagus Plumosus, strings	35.00 to 50.00	40.00 to 60.00 to 50.00 to 50.00
" " & Spren. (too bech.)	35.00 to 50.00	40.00 to 60.00	35.00 to 50.00 to 50.00

THE FLORISTS' SUPPLY HOUSE OF AMERICA

Without a rival in knowledge of the requirements of the trade and the ability to supply them. Our New Illustrated Catalogue, recognized as a work of art unprecedented in its line for variety, novelty and completeness, tells the story fully, and if you have not yet sent for it, do so now.

IT IS FREE TO EVERYBODY IN THE TRADE

H. BAYERSDORFER & CO., 1129 Arch St., Philadelphia, Pa.

PHILADELPHIA PLANT EXCHANGE

We aim to give our patrons the best values every week. Write us for anything you are in the market for. We handle your surplus stock also, our only charge being 10 per cent on sales.

THIS WEEK'S BARGAIN OFFERS:

500 PLUMOSA, 3 inch, \$5 00 per 100	500 FICUS CUTTINGS, well rooted, . . \$15.00 per 100
1000 MIXED FERNS, 3 inch, 7.00 "	3000 JOOST CUTTINGS, 17.00 per 1000
500 RUBBERS, 4 inch, 25.00 "	3000 MARION " 17.00 "
400 WHITMANI, 4 inch, 25.00 "	TODEAOIDES FERNS, 2½ inch, 20 00 per 100

ADDRESS ALL ORDERS TO

PHILADELPHIA PLANT EXCHANGE, 839 Market Street, PHILADELPHIA, PA.

Don't grow crops there is no demand for. Write us first. We cannot handle anything unless it is first class in every way.

To Cut Flower Growers and Retail Florists

IF YOU

want to find a market for your product

want a regular or special supply of the product of the best growers

Consult the Advertisements on these Wholesale Flower Pages

The Advertisers Represented Here are the Leading Concerns in the Wholesale Flower Trade

A Fine Assortment of

==AZALEAS==

Extra fine lot of **FIREFLY** in bloom from
NOW UNTIL EASTER

WRITE FOR PRICES

MAJOR BONNAFFON

The best all 'round Yellow Chrysanthemum. Strong stools,
\$5.00 per 100

W. W. EDGAR CO., Waverley, Mass.

FLOWER MARKET REPORTS

The rose market holds up satisfactorily thus far, but, outside of this, conditions are quite blinky. Carnations are coming in with a rush and there is no demand equal to the occasion, so prices have sagged badly and accumulations are the order in the wholesale marts. Violets are suffering to some extent from the same trouble, as is also all bulbous material. From all obtainable information, however, this market is as well-balanced at present as any in the country, and price fluctuations are moderate. The market quotations as given in HORTICULTURE are reasonably near the actual returns received by growers from day to day, and will be found on investigation to cover the situation as well as it is possible in a weekly report.

Trade was quite active
BUFFALO the past week, the weather being favorable especially at end of the week, it being more like spring than mid-winter. Floral work has been much in evidence, which has helped to clear up a little surplus stock, white carnations materially being much in demand. Lawsons were much too plentiful, especially the poor grades. Roses were a trifle more plentiful than heretofore, and demand was good on all lines of Teas. Beauties are in fine quality, but not too abundant, and prices holding firm. Mignonette, lilies, narcissi, peas, Roman hyacinths, lily of the valley, violets and freesla are in good supply.

At present everyone is taking things rather easy. While there are a good many orders daily there is plenty of time and material to fill considerably more. Fortunately most growers are off crop or else there would be a great deal of waste. In a couple of weeks we can expect a much heavier cut in almost every line and we have reasons to expect business to pick up by that time. Bridesmaid rose will have to give more way to La Detroit in this summer's planting; it will be more propagated than ever. Winsor and White Enchantress are also driving some of the other carnations from the local market. The Michigan Cut Flower Exchange shipped 300,000 fancy ferns last week; their weekly consumption is 150,000 on an average. Christmas orders called on them for most everything in the florist line, the principal items being carnations, 20,000; violets, 25,000; poinsettias, 3,000; boxwood, 1-2 ton; fancy ferns, 250,000.

The past week has been a fairly prosperous one with the trade, making allowance for the usual lull at this time. Beauties and tea roses are in a supply that is equal to the demand with prices a shade less than a year ago. Carnations are of fine quality and supply large. They have also suffered in price. Smilax is over-abundant while maiden-hair ferns continue scarce. Tulips, daffodils and peas find ready sale at good figures. There seems to be a good trade in all kinds of greens, galax leaves in par-

ticular. Tomlinson Hall market reports trade first class, wholesale as well as retail.

NEW YORK There is little to be said about conditions in the market at the present time, beyond stating that the falling market noted in our last report has continued steadily on its downward course and that prices are consequently from twenty to thirty per cent, lower on many leading things. Quality varies with the different growers, some of them sending in as fine material as ever was seen in this market and others sending the other kind. Neither are getting rich on the proceeds, but of whatever there is in it the first gets the lion's share, as he should. The variety of flowers in sight is increased by the addition of tulips, trumpet daffodils, calanthes, wall-flowers, freesias, callas and forced shrub bloom.

The marked improvement noted in our last week's report is not sustained this week. In fact, a slight fall is noticeable in many staples. The general market lacks snap. American Beauty and other roses dropped a little, with the exception of Brides. These are quite scarce. Carnations are easier. Violets and lily of the valley are very fair stock, but there is little go to them.

(Continued on page 82)

The KERVAN CO. 113 W. 28th ST. New York

WHOLESALE DEALERS
Fresh cut Palmetto & Cycas Palm Leaves, Galax, Leucothoe, Ferns and Mosses. All Decorating Evergreen.

JOHN YOUNG
WHOLESALE FLORIST
 Finest American Beauties and Carnations
 51 West 28 St. - NEW YORK

FORD BROTHERS
 48 West 28th Street, NEW YORK
FINE ROSES FANCY CARNATIONS
 A Full Line of All CUT FLOWERS
 Telephone, 3870 or 3871 Madison Square

H. E. FROMENT,
 Wholesale Commission Florist,
 Choice Cut Flowers,
 57 West 28th St., :: NEW YORK.
 Telephones: 2200, 2201, Madison Square.

The Reliable Commission House
 Richmond Roses and Rich Flowers
 of all varieties
JOS. S. FENRICH
 110 W. 28th Street, New York
 Tel. 324-325 Madison Square

Established 1891 BUY FROM SHIP TO TRY **ME**
ALFRED H. LANGJAHR
 All Choice Cut Flowers in Season
 55 West 28th St., New York
 Telephone 3924 Madison Square.

JOHN I. RAYNOR
Wholesale Commission Florist SELLING AGENT FOR LARGEST GROWERS
 A full line of Choice Cut Flower stock for all purposes. Comprises every variety grown for New York market, at current prices
 TEL. 1998 MADISON SQUARE 49 W. 28 St., New York City

Walter F. Sheridan
 Wholesale Commission Dealer in
CHOICE CUT FLOWERS
 39 West 28th Street, New York
 Telephone: 3532-3533 Madison Square

HEADQUARTERS FOR NOVELTIES
ORCHIDS A SPECIALTY
 THE HIGHEST GRADE OF **VALLEY** ALWAYS ON HAND
 GARDENIAS, DAISIES, ROSES AND CARNATIONS
 Telephone
JAMES McMANUS, 759 Mad. Sq. 42 W. 28th St., New York

PHILIP F. KESSLER 55 & 57 W. 26th St., New York City
 Commission Dealer, Wholesale Buyer and Seller of
CUT FLOWERS
 Open from 5 a. m. to 6 p. m. Sunday till 10 a. m.
 Tel., 5243 and 2921 Madison Sq. Res., 345 J., Newtown.
Finest Lilies in the Market Every Day in the Year.

WHOLESALE COMMISSION FLORIST **J. K. ALLEN** 106 W. 28 ST. NEW YORK
 Telephone 167 Madison Sq.
 OPEN 6 A.M. DAILY
 We have a good regular outlet for seasonable flowers

NEW YORK QUOTATIONS PER 100—TO DEALERS ONLY

	Last Half of Week ending Jan. 11 1908	First Half of Week beginning Jan. 13 1908		Last Half of Week ending Jan. 11 1908	First Half of Week beginning Jan. 13 1908
Roses					
Am. Beauty, lan and sp.	20.00 to 50.00	25.00 to 40.00			
" extra	15.00 to 20.00	8.00 to 18.00			
" No. 1	10.00 to 15.00	6.00 to 10.00			
" Lower grades	1.00 to 5.00	1.00 to 2.00			
Bride, 'Maid, lzo and sp.	10.00 to 12.00	8.00 to 10.00			
" extra	7.00 to 8.00	5.00 to 6.00			
" lwr. grs.	1.00 to 6.00	1.00 to 3.00			
Killarney, Richmond, lzo & spec	10.00 to 15.00	10.00 to 15.00			
" lower grades.	2.00 to 6.00	2.00 to 4.00			
Chatenay, Wellesley, lan. and spec.	6.00 to 8.00	8.00 to 10.00			
" lower grades.	2.00 to 4.00	1.00 to 3.00			
Golden Gate, Ivory	2.00 to 8.00	1.00 to 6.00			
Carnations, Fancy and Novelties	4.00 to 6.00	3.00 to 5.00			
" Ordinary	1.00 to 2.00	1.00 to 2.00			
Violets	.30 to .75	.30 to .50			
			Cattleyas	25.00 to 60.00	25.00 to 50.00
			Cypripediums	8.00 to 10.00	8.00 to 10.00
			Lilies	8.00 to 12.00	8.00 to 12.00
			Lily of the Valley	1.00 to 3.00	1.00 to 2.00
			Gardenias	10.00 to 25.00	10.00 to 25.00
			Roman Hy., Paper White Nar.	2.00 to 3.00	1.00 to 2.00
			Stevia	1.00 to 1.00	1.00 to 1.00
			Pignonette	3.00 to 6.00	2.00 to 5.00
			Adiantum	1.00 to 1.50	1.00 to 1.50
			Smilax	8.00 to 12.00	8.00 to 10.00
			Asparagus Plumosus, strigs.	25.00 to 50.00	25.00 to 35.00
			" & Sprea. (too bchs.)	10.00 to 15.00	10.00 to 15.00

B. S. SLINN, Jr.
 —WHOLESALE FLORIST—
 55 & 57 W. 26th St., New York City
 Tel., 3864 Madison Sq. Shipping Orders Solicited.
VIOLETS Roses and Carnations

Edward C. Horan
Wholesale Florist
 55 WEST 28th ST.
 Tel. 1462 Madison Square New York

TRAENDLY & SCHENCK
WHOLESALE FLORISTS
 Furnish best stock at fair prices all the year round Send for quotations on fall orders
 Tel. 798.799 Madison Sq. 44 West 28th Street, New York City

Alexander J. Guttman
THE WHOLESALE FLORIST OF NEW YORK
 43 WEST 28th STREET
 PHONES. 1664--1665 MADISON SQUARE
ENOUGH SAID

List of Advertisers

Table listing various horticultural businesses and their corresponding page numbers, including entries like Alleo J. K., American Nursery, Aschmann Godfrey, Atlanta Floral Co., etc.

CATTLEYA PERCIVALIANA ALVA.

This handsome cattleya, which forms the subject of our frontispiece, was collected in Venezuela in the Andes by Ordóñez Bros., and is now in bloom, bearing two flowers, and may be seen at Madison, N. J. The color of the flower is pearl white with a yellow throat. The flowers are very large.

PERSONAL.

J. F. Sullivan of Detroit is confined to his house by an attack of La Grippe.

A. Pericat, of Collinsville, formerly of Philadelphia, is very ill with pneumonia.

J. W. Rodgers was re-appointed superintendent of parks at Cincinnati, O., on January 1.

Detroit visitors: Harry Heim and Thos. McGee, Toledo; B. Eschner, Philadelphia, Pa.

Phil. Kessler, the New York wholesale florist, is getting ready to take a trip to Bermuda, combining business and pleasure.

Friends of J. T. D. Fulmer of Des Moines, Iowa, will be sorry to learn of his severe illness at his home. Pneumonia is the trouble, but the best is hoped for.

THE HAPPY GARDENER.

When you die, earth-lover,
Flowers shall be your cover;
Braver than the purple pall
Spun to veil dead kings withal.
You are weaving, day by day,
Beauty for the sun to slay,
The fleeting pageant of delight
That dwells within a garden bright.
You this Persian carpet spread,
And named it a sweet-william bed.
You painted this great lambent screen
Of larkspur, lilies white between.
You hang vine garlands low and high,
Ripe for Bacchus, reeling by.
You are the over-lord of grapes
And plums, and all alluring shapes
To win the eye and tempt the tongue,
Globed liquid honey, leaves among.
Living, you, an earth-born guest,
Are of men the mightiest;
And when you die, earth-lover,
Flowers shall be your cover.
—Alice Brown in Harper.

A RECORD FLORIST.

John H. Thiry, the 86-year-old School Commissioner of Long Island City, L. I., received many congratulations yesterday on the arrival of a small daughter at the Commissioner's home at 181 Academy street, in the Dutch Kills section of Long Island City. The newcomer is the fifth child born to the Commissioner's young wife since their marriage in 1896. She had come to this country with him from Belgium, and when Mr. Thiry's health broke down thirty years ago, the couple moved to Mr. Thiry's present home in Long Island City, where he devoted himself to raising fruit and flowers. Mr. Thiry said yesterday that he expected to live to celebrate his 100th birthday. N. Y. Times, Dec. 29, 1907.

ADVERTISE CARNATIONS.

Next issue will be full of interesting news for carnation growers. It will CIRCULATE at the Carnation Convention. See the point?

FLOWER MARKET REPORTS.

(Continued from page 77)

Orchids are selling fairly well. The mignonette supply is falling off but what is arriving is of good quality. Snapdragon and lilac have made their advent in limited quantity, and are a welcome addition. Trumpet narcissi are also coming in freely, and find ready buyers. Sweet peas are fine but prices are much below the average.

Since the holidays as a whole prices have not sunk very much, and there are no signs that they will go down in the near future, at least not as long as business keeps as good as it has since the beginning of this year. Carnations and roses are getting more plentiful now—at least the home growers are able to supply the market.

Business has been WASHINGTON quite brisk for the past week, and prices keep up. There is a decided glut of lily of the valley and also of cattleyas. The demand for carnations entirely equals the supply and prices keep up.

John T. Allan, who has for several years been the efficient captain of Hose Co. No. 3 of the fire department of Newport, R. I., has resigned. Among the candidates for the position thus made vacant are W. H. Maher and P. H. Reynolds, the former a florist and the other a gardener.

WANTS, FOR SALE, ETC. Advertisements in this column one cent a word. Initials count as words. Cash with order. All correspondence addressed "care HORTICULTURE" should be sent to 11 Hamilton Place, Boston.

SITUATIONS WANTED

SITUATION WANTED—As foreman or section man on an up-to-date place of roses; good grafter and propagator. American, married, aged 39, sober; good wages expected or will accept good private place. Have had charge for a number of years. F. C. Searies, Closter, N. J.

WANTED—Position with reliable wholesale or retail seed house as seedsmen; six years' reference with trustworthy seed firms; nationality, Scotch. Address Seeds, care Horticulture.

SITUATION WANTED in general greenhouse work; single, age 35, five years' experience, commercial. Address W. W., care HORTICULTURE.

FOR SALE

FOR SALE—On account of the recent death of my husband, I desire to sell our green house property located at Farmington, Conn., consisting of seven greenhouses, covering 12,000 square feet of ground, planted principally to carnations and violets. Stock in excellent condition, free from disease and showing lots of bloom at present time. Business established twenty-eight years and a ready market for entire output. With two acres of land, and a six-roomed cottage, with all modern improvements; stable, sheds, implements, etc. A splendid opportunity to a quick buyer. Address for further information, terms, etc., to Mrs. Hugh Chesney, Farmington, Conn.

FOR SALE—A large consignment of 16x24 double thick American glass, A and B quality. For further information write Parshelsky Brothers, 59 Montrose Avenue, Brooklyn, N. Y.

Is Your Name In The Above List? If Not, Why Not?

BOSTON HEAD LETTUCE AT IRON-DEQUOIT, N. Y.

The most important salad plant among the varied cultivated vegetables is the lettuce, of which there are more than a hundred varieties. It is in demand all seasons of the year, and is grown successfully in greenhouses, hot-beds and outdoors. The Irondequoit gardener has learned that to succeed he must have patience. This salad plant is essentially a cool-weather grower. It will stand slight frosts and come out all right. This sometimes happens with a gardener who is slow in getting heat connections made in the fall. What the Irondequoit gardener considers an important item in the culture of lettuce, is the choice of seeds and the best seeds procurable are bought. In the indoor crop, the seed is sown thickly in rows about two inches apart, and in a small bed. As the seed germinates and the young plant reaches a certain height the beds are thinned out and the stronger plants transplanted. When still larger many of the plants are again transplanted. By continual sowing and transplanting and selling, a succession is kept up the year around in many of the houses. Boston Head lettuce is considered the best for greenhouse cultivation. The tastes of the consumer must be catered to, and the grower after a good many years has found that Boston Head is the kind for all-round sales. Some consumers prefer the soft, delicate flavored varieties, others want the hard texture of the crisp sorts. The Boston or head varieties seem to fill these requirements. For general sales the head lettuce is most in demand during winter. It is a splendid shipper, and will keep fresh for several days on the local markets.

Lettuce growing has its disappointing features. Cloudy weather causes them to become mouldy and "damp off" if the soil condition is not right. Then plant lice are another nuisance, and fumigating with tobacco stems is the antidote.

The gardener has a "mascot" in every greenhouse. He is a quiet little worker, but he keeps the bugs scarce. It is the little "American Toad," and he is the greenhouse man's best friend in this line of work. They are especially of value in catching snails.

H. R. PEACHEY.

The Gardeners' Chronicle, London, for December 14, 1907, publishes a communication from a French correspondent concerning an insect (*Malacosma lusitanicum*) which has done great damage and caused considerable loss to the horticulturists in the neighborhood of Toulon who grow narcissi for the cut-flower trade. The beetles of this insect are abundant and well known in the central region of France, but the larval form has hitherto been unknown. It is the latter which feeds on the bulbs and several of them are sometimes found in a single bulb. Disinfection of the soil by means of bisulphide of carbon, applied at the rate of 240 lbs. to the acre, is recommended as a remedy.

"SCALECIDE"

HAS MADE SPRAYING EASY THEN WHY NEGLECT YOUR TREES?

The N. Y. Herald, November 17, '07, says: "The chances are about a hundred to one that you have the San Jose Scale on your place and do not know it," and advises the use of "SCALECIDE." This is good advice. "SCALECIDE" has been tested and tried, and found thoroughly effective. The same yesterday, to-day, and all the time. One gallon makes 15 to 20, ready to use, by simply adding water.

Prices: 1 gal., \$1.00; 5 gal., \$3.25; 10 gal., 6.00; 50 gal. bbl., \$25.00, F. O. B. our factory. Order to-day. Write for booklet W and free sample.

B. G. PRATT CO., Mfg. Chemists,
11 Broadway, New York City.

LIST OF PATENTS.

Issued December 31, 1907.

- 874,988. Wheeled Cultivator. Staley D. Poole and John Kiel, Moline, Ill., assignors to Deere & Company, Moline, Ill., a corporation of Illinois.
- 875,020. Automatic Stoker. Henry E. Wallis, Terre Haute, Ind., assignor to Wallis Stoker and Manufacturing Co., Terre Haute, Ind., a corporation of Indiana.
- 875,211. Spring Trip for Cultivators. Lewis Reeves and George K. Gilchrist, Vinton, Iowa.
- 875,235. Portable Stand for Flowers. Joseph F. Bastel, St. Louis, Mo.
- 875,236. Fastening Device for Split Carnations. Armin J. Baur, Millcreek township, Erie County, Pa.
- 875,233. Mowing Machine. Martin Jewell, Clinton, Me.
- 875,407. Plow Attachment. Josephus Bingaman, Garnett, Kans.
- 875,525. Compound for Spraying Fruit Trees. Charles J. Herring, Memphis, Tenn.

GREENHOUSES BUILDING OR CONTEMPLATED.

- Greene, N. Y.—L. Ford, one house.
- LeRoy, N. Y.—Fred Walter, house 20x75.
- Lenox, Mass.—C. F. Bishop, grapery, 24x60.
- Philadelphia, Pa.—James Bower, one house.
- W. Brentwood, N. H.—Bert Bartlett, two houses.
- Concord Junction, Mass.—F. L. Garland, one house.
- Williston, N. D.—M. Bartholomew, two houses, each 20x75.
- Zanesville, O.—C. L. Humphrey, two houses, each 50x100.
- Pittsburg, Pa.—Finleyville Floral Co., carnation house, 42x220.
- Berwick, Pa.—John A. Smethers & Son, two carnation houses, 25x65.
- Kearney, Nebr.—The Green Seed & Plant Co., two carnation houses, each 12x80.

NEW HEATING APPARATUS.

- Morris K. Jesup estate, Lenox, Mass., new boiler.
- Carl Swenson, Winsted, Ct., hot water boiler.
- W. S. Harry, Conshohocken, Pa., Lord & Burnham boiler.

ADVERTISE CARNATIONS.

Next issue will be full of interesting news for carnation growers. It will **CIRCULATE** at the Carnation Convention. See the point?

GREENHOUSE
GLASS

Cheaper Now Than For Years

We are taking contracts for next Spring delivery.

WRITE FOR OUR PRICES

STANDARD PLATE GLASS
COMPANY

26-30 Sudbury St. 61-63 Portland St.
BOSTON, MASS.



I MANUFACTURE AND ERECT

Iron frame and wood Greenhouses of every type for commercial and private use. If you contemplate building, allow me to submit sketch and estimate covering your requirements.

JOHN A. PAYNE,
Horticultural Architect and Builder.

Main Office and Factory:
260-274 Culver Ave., Jersey City, N.J.
Sash opening apparatus and all kinds of greenhouse structural material.

ANCHOR GREENHOUSE HOSE

WEARS WELL.
PLANT BED CLOTH
Protects from Cold and Dampness.

MINERALIZED RUBBER CO.
18 Cliff Street New York

BOSTON PLATE & WINDOW GLASS CO.

GREENHOUSE GLASS
German and American

261 to 287 A St., BOSTON 20-22 Canal St.

Tobacco Paper "NICO-FUME" **LIQUID**
 S THE
STRONGEST,
BEST PACKED,
EASIEST APPLIED.

Furnishes the Most Nicotine for the Money!

By far the **CHEAPEST.**

JUST NOTE PRICES!

24 sheets.....\$ 0.75	Pint.....\$ 1.50
144 sheets..... 3.50	½ Gallon..... 5.50
288 sheets..... 6.50	Gallon..... 10.50
1728 sheets..... 35.10	5 Gallons..... 47.25

Manufactured by...]
THE KENTUCKY TOBACCO PRODUCT CO., Louisville, Ky.

WILSON'S PLANT OIL

If you want to make money there is only one way. That is to have clean stock and the only way to get it is by using WILSON'S PLANT OIL.

New York Botanical Garden, Bronx Park, New York City, September 5, 1906.
 Mr. Andrew Wilson—Having used your insecticide here, I can testify to its efficiency in destroying scale and other insects infesting plants. Yours very truly,
 GEO. A. SKENE.

Florham Farms, Madison, N. J., December 8, 1906.
 Mr. Andrew Wilson:—Dear Sir—Your Plant Oil is certainly the most effective scale killer I have ever tried. Please send another five gallons. Yours truly,
 A. HERRINGTON.

PRICES: 1-2 pint cans, 25c; pints, 40c; quart, 75c; 2 quarts, \$1.25; gallon, \$2.00; five gallons, \$9.00. Cash with order.

ANDREW WILSON, Dept. 8, **SUMMIT, N. J.**
 Selling Agents for New England, R. & J. FARQUHAR & CO., 6 and 7 South Market St., Boston, Mass.

PATENTS

Trademarks and Copyrights

Send other business direct to Washington. Saves time and insures better service. Personal attention guaranteed. Twenty-five years' active service. SPECIALTY: "Working on the Failures of Others."

SIGGERS & SIGGERS
 PATENT LAWYERS
 Box 9, National Union Building
 Washington, D. C.



The Best Bug Killer and Bloom Saver

For PROOF Write to
P. R. Palethorpe Co.
 OWENSBORO, KY.

NIKOTEEN APHIS PUNK

THE ORIGINAL AND GENUINE
NICOTINE FUMIGANT
 STRONGEST AND MOST UNIFORM

NIKOTEEN
 LIQUID
 FOR SPRAYING OR VAPORIZING

NICOTINE MFG. CO. ST. LOUIS, MO.

STANDARD FLOWER POTS

Packed in small crates, easy to handle.

1500 2 in. pots in crate \$4.88	120 7 in. pots in crate \$4.20	
1500 2 1/4 " " " 5.25	60 8 " " " 3.00	
1500 3 " " " 6.00	HAND MADE	
1000 3 " " " 5.00	48 9 in. pots in crate \$3.60	
800 3 1/2 " " " 5.80	48 10 " " " 4.80	
500 4 " " " 4.50	24 11 " " " 3.60	
320 5 " " " 4.51	24 12 " " " 4.80	
144 6 " " " 3.16	12 14 " " " 4.80	
	6 16 " " " 4.50	

Seed pans, same price as pots. Send for price list of Cylinders for Cut flowers, Hanging Baskets, Lawn Vases, etc. Ten per cent. off for cash with order. Address **Hilfinger Bros., Pottery, Fort Edward, N. Y.** August Rolker & Sons, Agts., 31 Barclay St., N. Y. City.

CARMAN'S ANTIPEST

For the Garden, Orchard and Greenhouse.
 Non-poisonous and harmless to vegetation.
Kills Green Fly, Aphides, Bark Lice, Thrip, Mealy Bug, Red Spider, Scale, Wire Worms, Ants and Slugs.

This is the Grower's Friend, handy to use, cheap and effective, mixes readily in water. Destroys all insect pests, and keeps down filth. Circulars on application \$1.50 per gallon. Also in quarts, half gallons and in bulk.

PERFECTION CHEMICAL CO.,
 FLUSHING, N. Y.
 Eastern Agents:
W. W. RAWSON & CO., 5 Union St. Boston, Mass.

Holds Glass Firmly
 See the Point
PEERLESS

Glazing Points are the best. No rights or lefts. Box of 1,000 points 76 cts. postpaid.
HENRY A. DREER,
 714 Chestnut St., Phila., Pa.

Standard Flower POTS

If your greenhouses are within 500 miles of the Capitol, write us, we can save you money

W. H. ERNEST,
 28th and M Street WASHINGTON D. C.

The **FLORISTS' HALL ASSOCIATION OF AMERICA,** Insurer of 28,000,000 sq. ft. of glass. For particulars address **John C. Ester, Sec'y, Saddle River, N. J.**

Cattle Manure In Bags

Shredded or Pulverized

Best and safest manure for florists and greenhouse use, absolutely pure, no waste, no danger. Write for circulars and prices.
 The Pulverized Manure Co.,
 31 Union Stock Yards, Chicago

In ordering goods please add, "I saw it in HORTICULTURE."

In ordering goods please add, "I saw it in HORTICULTURE."

In ordering goods please add, "I saw it in HORTICULTURE."

WILLIAM H. LUTTON

HORTICULTURAL ARCHITECT AND BUILDER

WEST SIDE AVENUE STATION (C. R. R. OF N. J.)
JERSEY CITY, N. J.

Have not been established 50 years, but long enough to convince the wide-awake Florist and Gardener that it is to his interest to place his work in thoroughly practical hands.

(150,000 sq. ft. glass erected in 1907 will substantiate this claim.)

And why not? My material is the best that can be secured. My iron frame construction has every modern feature that years of practical experience can embody.

AND THEN THERE IS THE COST TO BE CONSIDERED.

Why not let us take up this important question now?

CYPRESS SASH BARS
 82 feet or longer
HOT BED SASH
PECKY CYPRESS BENCH LUMBER

GREENHOUSES

ERECTED AND EQUIPPED COMPLETE IF DESIRED

Write for Circular "D" and Prices

The A. T. STEARNS LUMBER CO.
 NEPONSET, BOSTON, MASS.

METROPOLITAN MATERIAL CO.
 GREENHOUSE WRECKERS

Everything in New and Second Hand

To
REPAIR HEAT BUILD GREENHOUSES

1398-1408 Metropolitan Ave.
 BROOKLYN, NEW YORK

I. CASSIDY

Designer and Builder
 OF

Iron and Wood Greenhouses

Office and factory, 215 to 221 Randolph Ave.
 JERSEY CITY, N. J.

GREENHOUSE CONSTRUCTION LUMBER

John C. Moninger Co.
 117 E. Blackhawk St., CHICAGO



INSURANCE

of your plants from **FREEZING** in cold weather
 at a trifling cost. Use a celebrated

LEHMAN WAGON HEATER

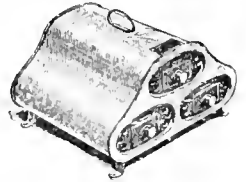

There is no danger of fire; no smoke, dirt or gases to injure plants. They burn **Lehman Coal**, which costs less than 1/2 cent per hour.

400,000 Lehman heaters are in actual use by **Florists, Horsemen, Agriculturists and Physicians.** Have you one? Write for new booklet with prices to-day.

LEHMAN BROS.

Manufacturers
 10 Bond St., NEW YORK
 BEWARE OF IMITATIONS.

J. W. ERRINGER

Gen. West. Sales Agent
 45 E. Congress St., CHICAGO
 Mention "Horticulture" when writing.

THE STANDARD STEAM TRAP

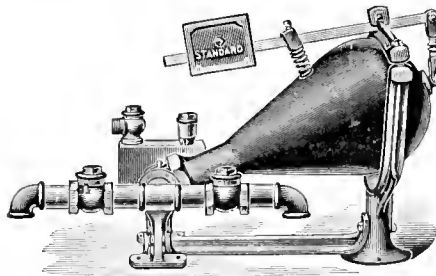

Is acknowledged the best for the florist, because it is durable and does its work without trouble and annoyance, saving its cost by the economy in coal bills.

E. HIPPARD

YOUNGSTOWN, OHIO

NOW IS THE RIGHT TIME TO FIGURE

MATERIAL

AND PLAN FOR THE BUILDINGS OF THIS YEAR

FOLEY'S

QUALITY AND WORK THE BEST.
 PRICES RIGHT AND LOWEST.
 ESTIMATES WILL PROVE. TRY US.

Foley Ventilating Apparatus Unequaled

Will ventilate any size of house easily. Send for Circular.

THE FOLEY MFG. CO. Western Ave. 25th & 26th Sts. CHICAGO



DANIEL ILIFFE

Greenhouse Construction—Supplies
Heating and Ventilating Steam and Hot Water Piping

On hand, a quantity of second-hand valves from 2 to 6 in. Send for Catalogue.

49 Washington Street, North,
 BOSTON, MASS.

H AND CO



If You Contemplate Building a GREENHOUSE

Write Us for Prices on

- The house erected complete.
- The Ironwork and Woodwork.
- The Heating Apparatus Erected.
- The Boiler.
- The Ventilating Apparatus, or any any part you desire to purchase.

HITCHINGS AND CO.

GREENHOUSE DESIGNERS AND BUILDERS.

Manufacturers of Heating and Ventilating Apparatus.

1170 Broadway,

NEW YORK.



INVALUABLE FOR THE GARDENER.

is this Greenhouse Book on the Sectional Iron Frame Greenhouse and its construction as applied to parks and private places only.

Send for it, and when you write, it will help us to complete our list of private places if you will kindly mention employers name.

We make every part of a greenhouse but the glass. We sell any part.

LORD & BURNHAM CO.

1133 BROADWAY, cor. 26th Street, N. Y.
BOSTON Branch: 819 Tremont Building
PHILADELPHIA Branch: 1215 Filbert St.



Then there is the downright practical side of U-Bar houses, the side that means more flowers, or vegetables of finer quality with less care and expense than in any other houses constructed any other way. The reason for this is, in short — *more light*. You see there is no gutter at the eave—no heavy members—the glass is spaced 24 inches instead of 16 inches. Every structural detail has been reduced to the smallest possible point. Still with all this extreme lightness of construction, there is not a more rigid, enduring house made—and it is the U-Bar that does it. The catalog, although filled with U-Bar houses, both exteriors and interiors, also shows plans, sections and all the interesting structural details that you like so well to know—Send for it. Pierson U-Bar Company, Designers and Builders U-Bar Greenhouses, Metropolitan Building, 4th Avenue and 23rd Street, New York.



HORTICULTURE

Vol. VII. JANUARY 25 1908 No. 4



WHITE FAIR MAID

*Devoted to the
FLORIST, PLANTSMAN,
LANDSCAPE GARDENER
and
Kindred Interests*

*Published
EVERY SATURDAY
At 11 Hamilton Place,
BOSTON, MASS.
Subscription, \$1.00*

DAHLIA CHARLES LANIER

BEST NOVELTY OF THE YEAR



We shall not describe it ourselves—the Press has already done so.

... WHAT THE PRESS SAYS ...

From the New York Tribune, Sept. 23, 1907.
At the Dahlia Show at the American Institute Exhibit.

Probably the most striking of the new Dahlia specimens is a brilliant yellow, its round blossom as large as the head of a baby, from the Charles Lanier Estate at Lenox.

Standing high and proud on their long stems in a huge yellow vase in the centre of a table, these magnificent blossoms caused audible exclamations as they caught the eyes of the visitors. This is their debut in New York, although they were recently shown in Boston.

From the New York Times, Sept. 27, 1907.
Newest Specimen at the Dahlia Show.

A large number of men and women visited the big dahlia show at the American Institute, 19 West Twenty-fourth St., yesterday afternoon. There were at least 200 varieties of the finest and newest spec-

imens of this beautiful Fall flower, and it would be impossible to tell how many colors and shades.

The most noticeable blossom was a big Charles Lanier which is known as the "show" dahlia. It is the old-fashioned quilled flower but of a mammoth size and beautiful yellow color. This was raised by A. H. Wingett, on the estate of Charles Lanier, Lenox, Mass., and named for the proprietor. Mr. Wingett has been at work developing the plant for the last three or four years, and it has now been awarded first prize and a certificate, which is a scientific sanction of it as a new flower.

The Charles Lanier dahlia probably will be sold before the exhibition closes and should bring a good price, for it stands alone in its class.

From Horticulture, Sept. 7, 1907.
Dahlia Show at Boston.

The dahlia show at Horticultural Hall, Boston, this week is unquestionably the

finest exhibition of dahlias ever given in America.

The sensation of the show is A. H. Wingett's Charles Lanier, a four-year-old, deep yellow in color, which may be appropriately described the Col. Appleton of the dahlias. The flowers, which came in excellent condition all the way from Lenox, are shown in one of the large vases occupying the centre of the stage in the lecture hall.

From "Dahlia News," September, 1907.
New Seedling Show Dahlia "Charles Lanier."

Twenty-four enormous perfect blooms of a bright yellow were exhibited in a large Japanese vase, and in effect it equalled the best vase of chrysanthemum. The special merit of this variety is the extreme length of stem, three feet or over, which makes it a most desirable variety for cutting. In size it equals any exhibition variety shown.

Plants to be delivered in May. Special prices to the trade only, as follows: Per dozen plants, \$3.50; 25 plants \$6; 50 plants \$11; 100 plants \$20. Orders to be filled in rotation as received.

R. & J. FARQUHAR & CO., 6 and 7 South Market St., BOSTON, MASS.

CARNATION CUTTINGS **DEPEND**

on receiving only **STRONG** and **HEALTHY** cuttings when you order from **US**.
WE HAVE ONLY THE NICEST AND BEST VARIETIES.

Write for further information to

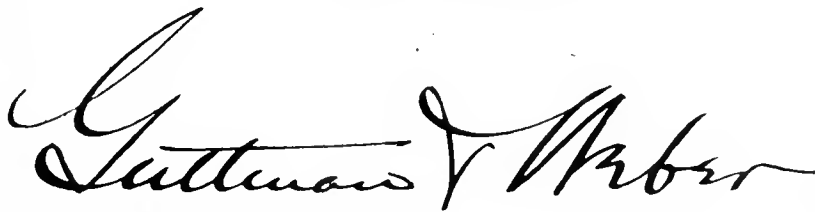

THE WHOLESALE FLORIST OF NEW YORK
 43 West 28th Street

GROWER
 Lynbrook, L. I.

Victory **Imperial**
 Pink Imperial
Aristocrat **Winsor**
 White Perfection
Welcome **Lieut. Perry**
Rose Pink Enchantress, etc.

PRESIDENT SEELYE

The new white carnation, seedling of Mrs. T. W. Lawson and The Queen.
 Tested for four years.

It has large, well-formed flowers, is fragrant and a free bloomer. The calyx does not split. It has long stems from the start. Does best in a temperature from 50-52 degrees. Plants warranted well-rooted and free from disease. \$10.00 per hundred, \$75.00 per thousand. **Orders Booked for February Delivery**

H. W. FIELD, : : Northampton, Mass.

LLOYD
IS THE REAL THING
The Carnation for every one to grow

LLOYD is a commercial white, with a fancy flower

The only ever-blooming, large-flowering white in existence

Will take the place of all other whites now in commerce. Every New Bedford grower has bought stock. Come and investigate.

A KEEPER
A SHIPPER
A BLOOMER

It will bring the shekels when all others fail

\$2 pr 12. \$12 pr 100. \$100 pr 1000
 Unrooted Cuttings
 \$6 per 100. \$50 per 1000.

H. A. JAHN
 NEW BEDFORD, - - MASS.

SPECIAL ATTENTION PRIVATE GARDENERS.
CARNATION CUTTINGS AND PLANTS

	2 1/2" pots	Per 100	Per 1000	Per 100
Andrew Carnegie, scarlet Harlowden the best scarlet for you to grow,		\$12.00	\$100.00	\$15.00
Aristocrat, beautiful cerise,		6.00	50.00	8.00
Welcome, silvery pink, very good, long stems,		6.00	50.00	8.00
Winsor, silvery pink, good producer,		6.00	50.00	8.00
Beacon, orange scarlet,		6.00	50.00	8.00
Red Chief, scarlet, produces 2-1 of any other scarlet,		6.00	50.00	8.00
White Enchantress, large stock of the true pure white,		6.00	50.00	8.00
Rose Pink Enchantress, true stock,		3.00	25.00	5.00
White Perfection,		3.00	25.00	5.00
Daybreak Lawson or Melody,		3.00	25.00	5.00
Victory, good scarlet,		3.00	25.00	5.00
Enchantress, large stock,		2.50	20.00	5.00

Special Prices on Large Quantities. **Send us your Order**
CHICAGO CARNATION CO. (A. T. PYFER, MGR.) Joliet, Ill.

JOHN E. HAINES
Bethlehem, Pa.

is the place to order rooted-cuttings of the following varieties for 1908.

John E. Haines, red } Per 100 Per 1000
 imperial variegated } \$6.00 \$50.00
 Pink Imperial, Pink }
 Enchantress, Light Pink }
 Place your orders early for Jan. delivery.

PURE ENCHANTRESS
WHITE

ROOTED CUTTINGS
 \$6.00 per 100 \$50.00 per 1000

JACOB SCHULZ
 644 4th Ave., LOUISVILLE, KY.

CARNATIONS **ROOTED CUTTINGS**

Winona, color, true clear pink, comes nearest to Fiancee but a different type flower. Growth on order of Scott but vastly improved in every respect. Early flowers in quantity and on long stems. Does not burst its calyx. Fine, shapely, active growth. In color and productiveness it is without an equal. Orders booked now and filled in strict rotation. \$12 per 100, \$100 per 1000.

White Perfection, pure white. We have a large stock. \$3 per 100, \$25 per 1000.

F. DORNER & SONS CO.
 LA FAYETTE, IND.

Winsor and White Enchantress

Strong Rooted Cuttings Now Ready for Delivery

WINSOR has proved to be the finest carnation in the light pink class. We sold a large quantity of it last year, but there will be a much larger sale for it this year. At the English Carnation Show held in December, it was the winner in the light pink class. It is doing well everywhere and will supplant everything in that color.

WHITE ENCHANTRESS will occupy the same position among white carnations that Enchantress does among flesh pinks. It has all the good qualities of the common Enchantress,—long stem, earliness, large size, freedom, etc. In our opinion, it is by far the best white carnation ever introduced.

We have a splendid stock of both Winsor and White Enchantress ready for immediate delivery, and will guarantee perfect satisfaction with the cuttings supplied. Do not wait, because the demand for these varieties is bound to be enormous. **Order early, while we can promise immediate delivery,** and secure gilt-edged stock. We have a large stock of both of these varieties, and all our cuttings are heel cuttings, taken from flowering stems. On account of the quantity that we are growing, we are not obliged to over-propagate, and our stock is in the most perfect and healthy condition.

Strong rooted cuttings from sand, \$6 per 100, \$50 per 1000. Extra strong transplanted cuttings from soil, \$7.50 per 100, \$60 per 1000. Strong established pot-grown plants \$9 per 100, \$75 per 1000.

F. R. PIERSON CO., Tarrytown-on-Hudson, NEW YORK

Rooted Carnation Cuttings

Pink	100	1000
Aristocrat	\$6.00	\$50.00
Winsor	6.00	50.00
Rose Pink Enchantress	3.50	30.00
Enchantress	3.00	25.00
Lawson	2.50	20.00
Joost	2.00	15.00

White	100	1000
White Perfection	3.00	25.00
“ Enchantress	6.00	50.00
“ Lawson	3.00	25.00
Queen	2.00	18.00
Boston Market	2.00	18.00
Louise	2.00	18.00
Lt. Peary	3.00	25.00
Bountiful	2.50	20.00

Red	100	1000
Beacon	6.00	50.00
Victory	3.00	25.00
Robert Craig	3.00	25.00
Flamingo	2.50	20.00

Miscellaneous	100	1000
Patten	2.50	20.00
Harry Fenn	2.50	20.00
Harlowarden	2.50	20.00

Stock Guaranteed—Prompt Deliveries
THE LEO NIESSEN CO.
 WHOLESALE FLORISTS
 1209 Arch St., PHILADELPHIA

Hardy Rhododendrons Azaleas Conifers, Clematis, H. P. Roses, Shrubs and Herbaceous Plants from our

HOLLAND NURSERIES

Prices Moderate

P. OUWERKERK, 216 Jane St., Weehawken Heights P. O. No. 1 Hoboken, N. J.

ROSES FOR FORCING Strong-Dormant Immediate Delivery

American Beauty, Clothilde Soupert, Gloire de Dijon, Hermosa, Kaiserin A. Victoria, Killarney, Liberty, La France, Laman Cochet, Marechal Nell, Mrs. R. G. Scharman-Crawford, Marchioness of Londonderry, Souv. de la Malmaison, including all the leading varieties of Hybrid Perpetuals.

BAY STATE NURSERIES, No. Abington, Mass.

NEW NEW

RAMBLER ROSE "NEWPORT FAIRY"

To be disseminated Spring, 1908. Ask for illustrated pamphlet and prices

JULIUS ROEHR'S CO., Rutherford, N.J.

ROSES Selected Stock for Forcing

CRIMSON RAMBLER and DOROTHY PERKINS

3 to 4 ft. \$1.50 per 10, \$12.00 per 100; 4 to 5 ft. \$2.00 per 10, \$15.00 per 100
HYBRIDS—All Leading Varieties, \$1.50 per 10, \$12.00 per 100
 General Catalog and Trade Lists on Application

The NEW ENGLAND NURSERIES, Inc., Bedford, Mass.

CATALOGUE OF New Chrysanthemums Roses, Etc.

Now ready, I am headquarters for the new singles, and carry the cream of the world's novelties. If you are interested send for my list. It's yours for the asking.

CHARLES H. TOTTY
 Madison, - - - N. J.

DAHLIAS. Now is the time to place your order for bulbs which will insure you getting named varieties in any quantity: prompt delivery.

DAVID HERBERT & SON,
 Successors to L. K. Peacock, Inc.
 ATCO, N.J.

Hardy Roses

American Grown—Superior to Imported
 We have unsold at the present time the following varieties—all field grown plants, grown in our nurseries at Rochester, N. Y.:

Anne de Diesbach	Prince Camille
Cllo	Ulrich Brunner
Franz Karl Druschki	Crimson Rambler
General Jacqueminot	White Rambler
John Hopper	Yellow Rambler
Mme. G. Luizet	Philadelphia Rambler
Marshall P. Wilder	Common Sweet Briar
Mrs. John Laing	Mme. G. Brant
Paul Neyron	Wichuriana (The Type)

These plants are in our storage cellars and can be shipped at any time. Prices on request.

ELLWANGER & BARRY
 Nurserymen—Horticulturists
 Mount Hope Nurseries, Rochester, N. Y.

100,000 DAHLIAS

Premium Stock, guaranteed true to name. 500,000 large Flowering Gladioli, hundreds of colors and variations mixed. Wholesale prices on application. Order now for spring delivery. Catalogue free.
J. L. MOORE, Northboro, Mass.

PRICES QUOTED IN THESE COLUMNS ARE FOR DEALERS ONLY When Writing to Advertisers Please Mention Horticulture

THE NEW CARNATION **AFTERGLOW**

Was Awarded a

GOLD MEDAL

(EXHIBITED BY W.T. NICHOLSON)

by the Rhode Island Horticultural Society at Providence, Nov., 1907.

CRAIG SILVER CUP

(EXHIBITED BY DAILEDOUZE BROS.)

by the Penn. Horticultural Society at Philadelphia, Nov., 1907.

FIRST PRIZE

(EXHIBITED BY THE E. G. HILL CO.)

by the St. Louis Horticultural Society at St. Louis, Mo., Nov., 1907.

FIRST PRIZE

(EXHIBITED BY THE ORIGINATOR)

by the State Florists' Association of Indiana at Indianapolis, Nov., 1907.

SCORED

the highest number of points of any seedling exhibited at the Toronto Exhibition of the A.C. S., Jan., 1907, after arriving 24 hours late from Framingham, Mass.

ASIDE

from these honors, the fact that it has been grown successfully wherever it has been tried is the best proof of its commercial value. Orders now booked by the undersigned, to be filled in rotation for well grown, well rooted cuttings at

\$2.00 per doz.; \$12.00 per 100; \$100.00 per 1000.

WILLIAM NICHOLSON,
Framingham, Mass.

THE E. G. HILL CO.,
Richmond, Ind.

DAILEDOUZE BROS.,
Flatbush, Brooklyn, N.Y.

R. WITTERSTAETTER, Originator,
Sta. F., Cincinnati, Ohio

AS a matter of Business Policy it pays to satisfy a customer. This is what I am aiming to do in order to have your good will as well as your trade. Rest assured that I will do all in my power to satisfy you, for I am well equipped (better than ever) to supply you

CARNATION ROOTED CUTTINGS

of high grade and can give prompt delivery. Pure WHITE ENCHANTRESS, BEACON, WINSOR, ARISTOCRAT, PINK IMPERIAL, \$6 per 100, \$50 per 1000. ROSE PINK ENCHANTRESS, WHITE PERFECTION, VICTORY, \$3 per 100, \$25 per 1000. ENCHANTRESS, M. A. PATTEN, HELEN GODDARD, HARLOWARDEN, \$2.50 per 100, \$20 per 1000.

Also the best novelties of the season's introduction at the introducer's prices.

DROP ME A LINE

S. S. SKIDELSKY, 1741 No. 18th St., PHILADELPHIA, PA.

"THE TEST is what TELLS THE STORY."

When growers who buy by the 100 the first season order thousands the next— **IT MEANS MERIT**

BEACON CARNATION

occupies this enviable position: as an all winter blooming scarlet **IT HAS NO EQUAL**

Strong, vigorous, healthy cuttings, ready now. Per 100, \$6.00; per 1000, \$50.00

Winsor, Per 100, \$6.00; per 1000, \$50.00	Rose Enchantress, . . . Per 100, \$4.00; per 1000, \$40.00
White Perfection, . . . " " " " 4.00; " " " " 35.00	Enchantress, " " " " 2.50; " " " " 25.00

Send Money Orders on Norwood, Mass.

PETER FISHER, Ellis, Mass.

CARNATIONS

WHITE ENCHANTRESS R. C.

This stock originated with and grown by me is the very best.

\$6.00 per 100, \$50.00 per 1000.

	Per 100	Per 1000
Enchantress, light pink,	\$2.50	\$20.00
Lawson,	2.00	15.00
Lord, light pink,	2.00	15.00
Queen, white,	2.00	15.00
The Belle, white,	2.50	20.00

250 at 1000 rate. Orders of 1000 or more will be shipped prepaid on receipt of check.

Get your R. C. early and have blooms when others have none.

FRANK H. KIMBERLY

631 Townsend Avenue, NEW HAVEN, CONN.

Winsor Carnations.

From 6000 plants we have plenty of exceptionally fine stock, and 50,000 ready for shipment now. From 2 1/2 inch pots, \$7.00 per 100, \$60.00 per 1000. Rooted Cuttings, \$6.00 per 100, \$50.00 per 1000

A. N. PIERSON, - - Cromwell, Conn.

WHITE FAIR MAID

Rooted Cuttings

\$10 per 100. \$75 per 1000

WELCH BROS., 226 Devonshire St.

ANNOUNCEMENT

Our new seedling carnation, **CREADOR,** will not be disseminated until January 1909.

For further particulars address, **The H. WEBER & SONS CO.,** Oakland, Md.

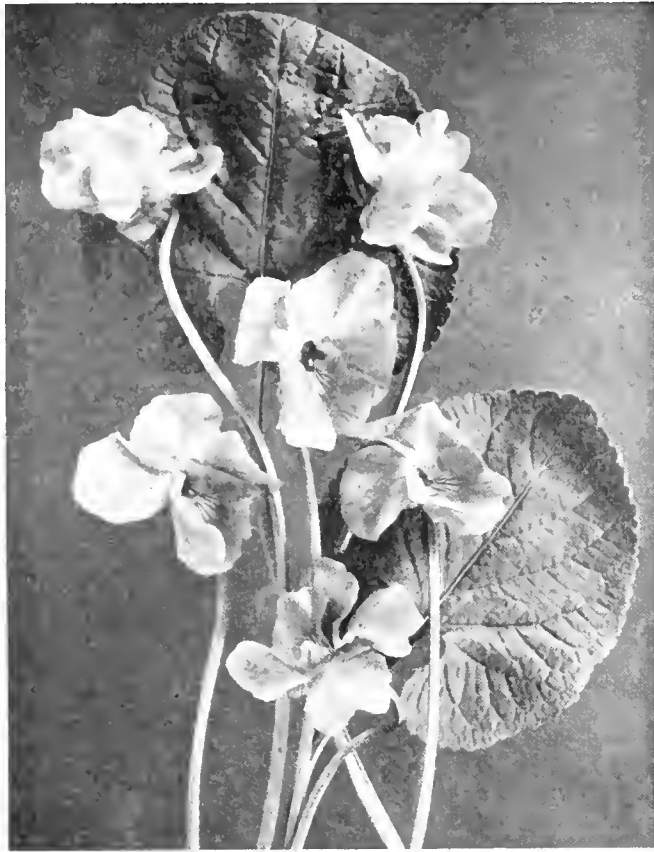

New Violet BOSTON

In introducing this new variety to the trade I wish to state that I have been growing it in quantity for the past two years and do not hesitate to state that it is entirely distinct, a strong grower, a free bloomer, and the finest single Violet in cultivation.

Ready for Distribution in April and May. Orders booked now.

\$2 per 12; \$12 per 100; \$100 per 1000
500 at 1000 rate

WILLIAM SIM
Cliftondale, Mass.

ANTON SCHULTHEIS

Wholesale Plant Grower,
College Point, - New York.

Price List of Foliage, Flowering
and Decorative Plants sent free on
application.

Just Received in Splendid Condition

15,000 AZALEAS

in all sizes and varieties

25c. up to \$2.00 each

Also Kent as, Rubbers, Araucarias,
Pandanus, Boxwood, Euonymus,
Crotons, Areca and Eurya latifolia.

Extra good value in large

Specimen and Decorative Palms

A. LEUTHY & CO.

Perkins Street Nurseries, Rosindale, Mass.

GODFREY ASCHMANN

Importer and Wholesale Grower
and Shipper

of Araucaria Excelsa, Compacta, Robusta and Glauca;
Kentia Forsteriana and Belmoreana Azalea, Indica, etc.
Cultivator of Boston, Scottii, Barrowsii, Elegantis-
sima and Whitmanii Ferns. Ferns for dishes, Cocos,
etc. Write for prices.

1012 Ontario St., Philadelphia

NEW ——— A MONEY MAKER ——— NEW CARTER'S DOUBLE BLUE LOBELIA

\$2.50 per doz., \$18.00 per 100

CASH WITH ORDER PLEASE. J. FULLER, 31 Orchard St., LEOMINSTER, MASS.

JOHN SCOTT

Grower of PALMS, FERNS and Other Deco-
rative Stock

NEPHROLEPIS SCOTTII All the Year Round

Rutland Road and East 45th St.

Telephone 2890 Bedford BROOKLYN, N. Y.

NEP. WHITMANI

2¼ in., \$5.00 per 100

NEP. WHITMANI

3½ in., \$25.00 per 100

BOSTON FERNS

2¼ in., \$3.00 per 100

H. H. BARROWS & SON Whitman, Mass.

FERNS

Boston, 4 inch 12c, 5 inch 25c.

Pierstonii, 3 inch 8c.

Elegantissima, 2¼ inch 6c, 3 inch 10c,
4 inch, 15c.

BAUR FLORAL CO., Erie, Pa.

Established 40 Years

Rose Hill Nurseries

New and Rare Plants

NEW ROCHELLE, N. Y.

New York Office, Siebrecht Building, 425 Fifth Avenue

CANNAS

Send for our List and
Prices

The **CONARD & JONES CO.**
WEST GROVE, PA.

LILIUM AURATUM

9-11 \$75 per 1000

ROSEUM and RUBRUM

9-11 \$65 per 1000

MULTIFLORUM

7-9 \$45 per 1000

D. RUSCONI, 128 West 6th St., CINCINNATI, OHIO

ROBERT CRAIG CO.

ROSES, PALMS,

and Novelies in Decorative Plants

MARKET and 49th STREETS., PHILADELPHIA, PA.

THE FINEST

Lily of the Valley Excellenta

From cold storage. Only few cases left. Please
order at once. \$32.00 per case of 2000 fine pips.

JOHN SCHEEPERS & CO.

4 & 6 Old Slip, - - NEW YORK.

Cyclamens in England



The accompanying illustration shows one of the cyclamen houses at the Royal Gardens, Sandringham, and was taken exactly thirteen months after the seed was sown. The cyclamen being a great favorite with King Edward and Queen Alexandra quite a large number of plants have to be grown each year, and the high quality which is maintained year after year, reflects great credit upon Mr. Cook, the able superintendent of this noted establishment. The Sandringham strain of cyclamen is now well-known in England, Mr. Cook having made these plants a specialty for many years, and devoted a great deal of time and labor in bringing the strain to its present high state of perfection. The methods which he followed are most interesting. A few years ago he collected from various sources the best seed which he could possibly obtain. Not being satisfied with the varieties which then existed, he took in hand regular and systematic fertilization of the finest, having in view richness and substance in the flower, symmetry and length in the stem, and glossy marbled foliage. The results obtained I may say, have quite exceeded his expectations. Personally, I have never seen a finer lot of plants, and I am certain that he possesses at the present time a strain which cannot be equalled in Britain. Surely this system of private selection is well worthy of emulation by growers on this side of the Atlantic.

Wm. W. M. Brown.

North Easton, Mass.

British Horticulture

SWEET PEA TRIALS

The National Sweet Pea Society has arranged to have another series of trials of new varieties at the University College Gardens, Reading, this year. Last year's trials proved very successful, demonstrating the

practical value of this side of the Society's work. The chief objects of the trials are to enable the committee to have an opportunity of inspecting the new varieties growing under similar conditions. It is intended to grant awards of merit or first-class certificates to those varieties in the trials deserving these awards. A glance at the seedsmen's lists reveals the fact that there are too many varieties listed, and the multiplication of novelties only serves to confuse growers when a selection is made. The decision of the committee to only grant awards after the novelties have been included in the trials is well advised. It will prevent needless duplication besides allowing the committee to ascertain whether a variety is properly fixed. There have been disappointments in the past when a certificated new-comer was found to be totally unreliable. When it is found that the certificates have been awarded after a full and careful trial, such as that which can be relied upon at Reading, their value will be enhanced in the estimation of growers.

SOME NEW VARIETIES

Amongst the many new varieties which are being sent out this year the now favorite Spencer type, with a wavy form, appears to predominate. St. George, which is described as of a brilliant carmine-scarlet tint, of the Spencer type, received the silver medal for the best new variety in 1907 at the National Sweet Pea Society's show, besides a first-class certificate. It also received an award of merit from the Royal Horticultural Society last summer. Princess Victoria, which was so much admired, when exhibited last summer, is a delightful shade of soft pink somewhat similar to Mrs. Hardcastle Sykes. It received an award of merit from the National Society and from the Royal Horticultural Society. The Marquis is a mauve Spencer, and has also received an award of merit from the National Society. Norah Unwin is a decided advance on Gladys Unwin or Frank Dolby. The pure white flowers are of fine form and substance, and it is likely to prove a strong rival to Dorothy Eckford. Other new aspirants for fame are: Lord Nelson, navy blue; Evelyn Hemus, pale creamy with carmine edge; Clara Curtis, a cream Spencer; Rosie Adams, rosy mauve; Silas Cole, named after the raiser of Countess Spencer, of a darker shade than the former variety; Pride of Althorp, lavender blue; Lord Althorp, an improved Helen Lewis; and Miss Delia Spencer, rose pink.

NEW SINGLE FLOWERED CHRYSANTHEMUMS

Amateurs are recognizing to a larger extent the value of this section of chrysanthemums. The following is a list of new varieties which are being sent out: Lady Mayoress Sayers, yellow; Pink Felicity, bright pink; Felicity, ivory-white, large, prominent yellow disc; Victoria, yellow; F. W. Smith, rose-pink; Mrs. C. Radclyffe, rosy-carmine, with a clear white ring next the disc; Exquisite, crushed-strawberry; Blanche, white; William Grix, canary yellow; Ruby, late, ruby-crimson; Mrs. N. E. Barnes, yellow, flushed bronzy red; Mrs. Robert Armitage, terra-cotta; Mrs. H. A. Witt, bright mauve, with a narrow zone of white next to disc; Maisie Lyon, deep rose.

A NEW WINTER WASH

Some good results have been obtained with a new winter wash known as V1 fluid. Mr. Walter E. Collings, head of the Department of Economic Zoology in

the University of Birmingham, who has conducted some exhaustive experiments with the preparation, records: "In one orchard where it was tried on about a hundred acres of apple, pear, and plum trees, and 34 acres of various fruit trees, apple-sucker, apple aphid, plum aphid and mussel scale were exceedingly bad last year. A careful inspection was made in March of some thirty or forty of the worst-attacked trees, and not a single egg of any of these pests could be found alive." Another disadvantage is that hitherto Mr. Collings has had to use one preparation for insect and another for parasitic fungi, such as the moulds, mildews and rusts, but this new fluid is said to be as deadly to the latter as to the former, and a single spraying will suffice.

W. H. Adsett.

Tomatoes Under Glass for Early Summer Crop

It is only within the last few years that tomatoes have been grown to any great extent for an early summer crop under glass, around Boston. Many growers seeing others succeed are now taking up this industry. The credit, however, belongs to those who embarked in the business and in spite of the large quantities coming from the South showed the people that the home-grown article was so much better and that a price could be realized from them in proportion to their value. Many flower growers might add something to their revenue by growing them. Houses that have held Easter stock, violets, or others that are not paying, might be planted with tomatoes when otherwise they would be idle. It is not necessary to plant early to have an early summer crop. Any time in April or even the beginning of May is right. Your big pick will then be on in the early part of July which is the time they sell the best. The prices may not look big to some,—10 to 15 cents per pound,—but at that season of the year what else could you get any more out of? Well-grown plants will bear six pounds and over and the space occupied is about twenty inches square. Of course there is the growing on of the young plants which should be in four-inch pots and in bloom at the time of planting, but they can be grown to that size for about \$1.00 per hundred.

The labor in growing tomatoes is likely more than in most crops, but I think the revenue will be larger in proportion. Of course it will not pay to grow them unless you go about it in the right way. The plants must be kept tied up and trimmed and as they make a very rapid growth you must be right after them, otherwise your past labors may amount to very little. They are gross feeders and from the time the fruit starts swelling they must be fed and fed high. My past experience has shown that they do not care for clear water at any time after the fruit is the size of plums. They, however, should not be fed on anything that is green. I have found that liquid made from well rotted horse and cow manure is the best thing to feed with. The second week of August the crop will be through and the house may be put to any purpose desired. A treatise on growing may be given later if desired.

William Lin

Plant! Plant!

A mighty timber famine is at our very doors. Plant quick-growing trees which will soon bring results. The cotton-wood, Carolina and Norway poplars bring in speedy results. There are low, wet places which for twenty-five years have done nothing but raise weeds; set them to raising houses and barns for yourself and children. The soil from your hillsides is going down to the gulf; lariat it, make it stay at home. Fasten it with evergreens. The cream of your land is being wasted; it is a crime to allow this. The bleak fields need protection in winter. The crops need defense from the sweeping hot winds—so plant wind-breaks.

You are king by divine right. Your domain reaches from the center of the earth up to the stars. For you the forces of Nature are at work. Out on the oceans, Nature sets numberless pumps to work to load those squadrons of the air which pour abundance on your fields. For you there is power in those lances of light which come from the sun. All the air is filled with viewless armies, working for you. For you that orchard toils, and for you those young forests would labor as faithful serfs. Plant flowers and they will spring up and give you worshipful reverence. As supreme in your kingdom, you should make the very best of it, and have your place match the beauty of the surroundings, the glory of the skies, the attraction of the fields, the splendors of the morning and the evening. Too often the home is like a plague spot—a carbuncle on the fair face of Nature.

THE HOME

is not a sty, a kennel, a barn, or a workshop. It is a place where immortals live to fit themselves for eternal beauty which is their heritage. Don't be content with raising pork, grains, and fruits and vegetables for the body; raise something to feed the soul. Remember, beauty is wealth, and you can raise it as easily as you can corn and potatoes. The pioneer stage, with its hard struggle is past. We are in a new era, now, where we can afford the home beautiful. It should be the most attractive place on earth—a precious memory for children in all the after years. I recall two homes—one is surrounded with flowers. It was beautifully transformed by the owner. In the rear, was a grove of spruce which he planted, himself. The rows were like aisles in grand temples. The trees were like columns, supporting that arch of green. That grove was full of play-houses and play-things. All the influences were purifying and inspiring. How the children loved that home, and when they went away, how eager they were to get back again, and when they grew up, they wanted to settle near it.

The other, is a bleak house, out on a great prairie. There is the eternal grind. In the yard, not a bush or tree or flower. In the house not a carpet or rocking-chair, no pictures nor magazines. It is work, work. The father is like one of the old slave drivers; the children, slaves. Result: Three beautiful girls who might have made noble wives and mothers, were easily lured to the bad. You could write ruin on their blighted lives.

Anything was better, they thought, than such dreadful, dreary drudgery. The five boys left as soon as they could get away—only one amounted to anything. The rest were hoboes. These might have been noble men, leaders in society, enterprising citizens. Father and mother are left all alone in their desolation. Every child was as eager to get away as a convict to escape prison. Nothing could call them back. The man has his money, \$75,000, but the children are gone—sold! sold! by their own father. Does this pay?

A father once said to me, "I am having trouble with my boys. I have lost control of them, and sometimes they steal my money. I am afraid they are going to the bad." He wanted me to visit him. The man had built a fine store in a near by town, he had a half section of land, but was living in a miserable house, and his boys had to go to bed in a stuffy garret so low they had to crawl into bed on all fours. He never encouraged them or paid them anything. They worked hard and thought they should have some remuneration if they had to steal it.

Right here, let me say, the boy is a good deal as his father moulds him. A man should keep his promise to his son as most sacred, and on no account violate it. He should see that the son keeps his promise to him to the letter. Some fathers have written contracts with their boys, so that everything will be in black and white, so that either can point out any lack on the other side. In contrast with the den above described, I visited a father who built a new house and saw that his boys had one of the finest rooms. I was visiting him and noticed that the two sons, sixteen and eighteen, were taking hold of the work as though they owned the place. They seemed to show good judgment, and acted as if the whole responsibility was on their shoulders. I congratulated the father. He said, "I pay that oldest boy eighteen dollars a month and the other twelve dollars. I want them to have some self respect, and feel that they are earning something and it teaches them how to take care of their money and then we live for our children, anyway. What incentive would we have without them?"

Too often, children have less attention than the cattle and the horses. Oh! the shame of it, when they should be trained as kings and queens for a royal heritage. Strange, the parent can not look over into the future and see an ideal for that little toddler—a leader among men, crowned with riches and honor, his own prolonged life on a grander scale. Let the children associate with the pure and the beautiful. Have that front yard an Elysium. Have every attractive thing in it which can be made to grow—a charming array of trees, shrubs, and flowers. Have the girls associate with the best dressed and best behaved company on earth. Children are influenced by their surroundings. Interest the boy in the finest flowers that bloom and he will be a gentleman and not a boor.

A man who saw that he was going to lose three calves, said to his three sons, "You may have, each of you, one of these calves, if you will save them." They did. How much they found out of the best way to raise stock. Two years passed and he said at the table, "I think I shall sell my three steers, tomorrow; they will bring fifty dollars apiece." The boys noticed it. He had to go away that afternoon; when he came back, there were not any steers. The boys said, "We will teach Dad to be honest." Children will get tremendously in earnest if you will let them study all out doors. The structure of the plant, the unfolding of

the flower, grafting, budding, planting, all are so much more interesting than poring over dull books.

Interest the boy in the choicest trees, shrubs, and flowers. Let him write their names on labels and tie them on till he knows them by heart. Let him study their history, interest him in the creation of new varieties, teach him the principles of hybridizing, call out the Divinity within him. Let him understand that he, too, can be a creator, that he can call out of the unknown, things rare and beautiful which no other eyes have yet seen, and you have lifted him to a higher plane and given him a start worthy of his parentage, so plant and raise refinement and beauty.

"Oh bosh on your beauty!" did you say? "There is no money in it." Yes, but back in your soul, there is a lurking love for it after all. You married the most beautiful girl you could find; you drive a fine team—I notice you did not buy a dilapidated buggy at an auction but got a new carriage. Your colts and calves are beautiful and you keep them so. Those round and plump pigs with those fashionable kinks in their tails just please you. Sneer as you will, you love the beautiful; now go and raise a lot of it in that front yard.

C. S. Hammon

York, Neb.

Euonymus alatus, Maxim

The autumnal coloring of our trees and shrubs contributes in no small degree to their value for ornamental planting, and, fortunately, the appreciation of this truth is constantly growing. Unique in respect to its autumnal beauty is this Asiatic congener of our own Burning Bush. Although native to China and Japan, *Euonymus alatus* is quite at home in our gardens and grounds where it becomes a compact, spreading, symmetrical shrub and attains a height of five to eight feet, and a spread of equal proportions. It is distinguished from the other members of its group by the pronounced corky wings or plates on its branches, which give them the appearance of being four-angled. The flowers appear in early June. They are small, yellowish and, like those of many of this same group, unimportant. The fruit which follows is small, borne on short stalks singly or in groups of two or three, and opens its capsule from the middle to the last of September. The pod is purplish and the aril of the seed is scarlet. However, the fruit does not render the plant showy for not only is it scattered but, before the leaves fall, it is partially concealed. The foliage is neat, of good color and in the autumn turns to a cheerful rose-pink which is most delightful. In fact as regards beauty of autumnal splendor it ranks very high among ornamental shrubs. As to requirements, it does not appear to be fastidious though of course it needs good treatment for the best results. The neatness of its habit and the goodness of its foliage make it desirable when a specimen shrub is sought, and render it indispensable to the shrubbery.

Daniel A. Clarke.

HORTICULTURE

VOL. VII JANUARY 25, 1908 NO. 4

PUBLISHED WEEKLY BY
HORTICULTURE PUBLISHING CO.
 11 Hamilton Place, Boston, Mass.
 Telephone, Oxford 292
 WM. J. STEWART, Editor and Manager

SUBSCRIPTION PRICE
 One Year, in advance, \$1.00. To Foreign Countries, 2.00. To Canada, \$1.50
ADVERTISING RATES
 Per Inch, 30 inches to page \$1.00.
 Discounts on Contracts for consecutive insertions, as follows:
 One month (4 times) 5 per cent.; three months (13 times) 10 per cent.;
 six months (26 times) 20 per cent.; one year (52 times) 30 per cent.
 Page and half page spaces, special rates on application.

COPYRIGHT, 1908, BY HORTICULTURE PUB. CO.
 Entered as second-class matter December 8, 1904, at the Post Office at Boston, Mass.
 under the Act of Congress of March 3, 1879.

CONTENTS

	Page
FRONTISPIECE—White Fair Maid.	
CYCLAMENS IN ENGLAND—Wm. McM. Brown—Illustrated	95
BRITISH HORTICULTURE—W. H. Adsett	95
TOMATOES UNDER GLASS—Wm. Sim	96
PLANT, PLANT!—C. S. Harrison	96
EUONYMUS ALATUS—D. A. Clark	97
ABOUT FERTILIZERS AND THEIR USE—Dudley M. Pray	99
THE HYDRANGEA CONTROVERSY—E. G. Hill	99
AFTER ADJOURNMENT	100
OBITUARY	100
AMERICAN CARNATION SOCIETY	
Portraits of Officers	101
Program and Schedule	101
Transportation	102
SOME PROMISING CARNATION NOVELTIES	
House of Afterglow, Illustrated	102
President Seelye, Illustration	102
Three Promising Carnations, Illustrated	104
White Fair Maid	104
Andrew Carnegie, Illustrated	105
A GROUP OF WASHINGTON'S BUSY MEN—Portraits	103
NEWS OF THE CLUBS AND SOCIETIES	
Newport Horticultural Society—American Breeders' Association—Engelman Botanical Club—New Haven County Horticultural Society—New President of Chicago Florists' Club, Portrait of Leonard Kill—Detroit Florist Club—Minnesota Crop Breeders—Gardeners' and Florists' Club of Boston—Greenwich Gardeners' Society	106
Southampton Horticultural Society—Ginseng Growers—Society of American Florists—Florists' Club of Washington—American Rose Society—Club and Society Notes	107
DURING RECESS	
Tarrytown Horticultural Society—Sporty New Haven—Fun at Madison	109
SEED TRADE	112
FLOWER MARKET REPORTS	
Boston, Buffalo, Detroit, Indianapolis, New York, Philadelphia, Washington	117
MISCELLANEOUS	
Personal: D. E. Roy, portrait	100
Carnations in New Bedford	104
Home Production of Lily Bulbs	105
Appraisers' Decisions	107
A New Nursery	105
An Interesting Seedling	105
New Forester at Iowa State College	108
Potamic Gardens and Their Uses—A. S. Kinney	108
Catalogues Received	109, 111
Publications Received	114
Flora Imports	112
Philadelphia Notes	114
Dayton News	114
News Notes	114
Fire Record	114
Business Changes	115
New Retail Stores	115
Incorporated	115
Greenhouses Building or Contemplated	125

According to custom **HORTICULTURE** for the fourth time takes up its annual prerogative and extends cordial greetings to the carnation industries of our country and the Society which so ably represents them. In preceding issues we have urged the value of the meetings and exhibition which are about to open in Washington and the importance of attendance and participation by every grower of the divine flower who has any aspiration for excellence or prosperity. We hope to see the largest gathering in the Society's history and that the proceedings may widen the sphere, elevate the standard and fire the ardor of those whose lives are dedicated to the interests of this flower of the people.

Just how far the winning of high honors under the exacting rules of the exhibition table as to form, size, etc., will go as an endorsement of a variety for every day florists' needs is no new question with the carnation society or, indeed, any society similarly devoted to the improvement on precise lines of any special flower. Some of the qualities that make for utility and serviceable availability for the florist whose primary demand upon a carnation must be that it "brings grist to his mill" as a cut flower, are not easily made apparent on the exhibition table and as advancement towards the ideal goes on from year to year the problem may be expected to grow in importance. For the dealer enjoying the support of critical buyers willing to pay for fine finish nothing can be too good. He should encourage with the utmost liberality the striving for high grade material which is the keynote of successful competitive exhibiting. But the lack of superiority in these points is not enough in itself to condemn a carnation for every day market uses.

Catalogues, catalogues, by every mail, from all points, domestic and foreign. What an enormous expenditure, or investment rather, they represent in the aggregate! To any one who has had occasion to follow up the catalogue industry the remarkable advancement in quality, within a decade even, is conspicuously apparent. Half-tone illustrations of high artistic excellence have replaced the crude productions of a few years ago and the cheap wood cut has practically disappeared. In cover adornment, quality of paper and beauty of typographical work no expense has been spared, apparently, and after the book is completed then comes the outlay for mailing—an amount little realized by most of us. And yet, while prices of everything which appertains to catalogue making have vastly increased, the prices on seeds, plants, and sundries as quoted are no higher but in many instances lower than they were in years gone by. The seed and nursery catalogue makers have contributed much to the general store of popular horticultural knowledge; in intelligence, liberality and enterprise they stand in the front rank of the profession and are entitled to the respect and gratitude of every one who likes to see horticulture flourish.

Two standards of value

The catalogue season

About Fertilizers and their Use

SOLUBILITY

To dispose of this term solubility when used in its broad sense would be to go to the roots of all science, while to attempt to do so within the compass of a few words would be chemical sacrilege. Chemical conceptions of any sort, especially concerning solids, are always complicated with questions of solubility. The alkali of the Western plains makes vast areas inhospitable to plant life and troublesome to eradicate because of its everlasting solubility. The slow but certain action of the elements making our granite rocks yield up their stores of potash for vegetable growth is largely a question of solubility. The only "Open Sesame" at the plant root is solubility. Animal and vegetable life both are dependent upon solubility.

Every day conditions upon this planet are such that we immediately associate solubility with that combination of elements called water. Water and solubility.

The illimitable solvent action of water needs no proof or elucidation here. Even our late friend Jernegen of Gold-Sea-Water fame was right, for sea water does have gold—some—and likewise many other minerals which dissolve by the conditions in Nature, although gold is one of the most obdurate metals, being dissolved by only the strongest acids. Yet gold is not soluble in water in the common acceptance of the word for it does not dissolve easily and entirely in a moderate amount of water. Such substances as sugar, nitrate of soda or sulphate of potash do, although not to the same degree because sugar will dissolve in twice its weight of water, pure nitrate in nearly its own weight while the sulphate takes ten times to become dissolved.

The simple solvent action of water, while remarkable, should not become confused with that obtained when combined with agents as air or the juices from bacteria. Many "mixed fertilizers," blood or bone, are insoluble and require something besides water to dissolve them.

In this connection the great influence of the fineness of fertilizing materials should be noted for its great practical importance. The ease or otherwise with which it yields up its value depends largely upon the amount of surface exposed or in other words upon the working surface. Fine grinding makes surface grow in astounding fashion and therefore even if the solubility is slight the work done in a given time is vastly increased and the maximum effect is reached with the finest powder.

Everybody is cognizant of this truth and note its application to bone. Being of slight solubility in water its immediate value depends to a great extent upon its fineness. Almost any action upon it from any agent will be aided by large surface. To have bone last a long time we use "inch" bone. To have it last years we use "meal." To get its value as near to "now" as possible, use very fine. But no grinding mill ever made by man can begin to equal the smallness of the particle of a fertilizer already dissolved in water yet fine grinding does advance a little along the road of solubility.

The great importance to the plant of this question of solubility lies in the accepted fact that no solid can be taken in by the root. Whatever necessary mineral is wanted by the plant must first be dissolved; to be admitted to the internal works it must be as a liquid.

Rudley M. Pray

The Hydrangea Controversy

Editor of HORTICULTURE:

The criticisms on the name bestowed by our firm upon the Hydrangea known as *arborescens alba grandiflora* have been duly noted. If Professor Bailey, in using the name *H. arb. var. sterilis*, copied same from Asa Gray's works this would not prove the one described by Gray and the variety named by ourselves to be identical, by any means. We cannot conceive that so valuable a shrub as the variety named by us could possibly have escaped for so many years the attention of those interested in hardy shrubs.

The dissemination of *H. arb. alba grandiflora* was brought about through agencies quite unusual. It was not disseminated by any nurseryman or plantsman, but was widely scattered by private individuals through a stretch of country embracing Dayton, Piqua, Springfield and Yellow Springs, Ohio. In this particular one of our critics makes us say that we knew it was held and grown by a large number of plantsmen. If the word plantsman as used means those in the trade then such reference is incorrect and untrue.

I cannot see that either the secretary of the S. A. F. or ourselves are to blame for the part taken in naming and registering the variety *H. arbor. alba grandiflora*. It is conceded that we were the first to describe and offer the variety in a commercial way. Mr. E. Y. Teas, who has furnished a number of notes on the variety under the name *arb. sterilis*, saw the plant blooming for the first time on our place and we had the privilege of calling his attention to it.

The fact that one or two foreign horticultural journals call this hydrangea by the old botanical name should not outweigh the fact that nearly all the catalogue men in this country use the name given by our firm. With all due respect to the critics it does seem as if a mountain had been made out of a small affair. We have not believed the variety named by us to be identical with the variety described by Gray and Torrey and until proof is forthcoming that such is the case we shall decline to drop the name given by us. Let those who are contending so strenuously bring the proof that such is the case and then we will cheerfully surrender the name given by us.

Hind-sight criticism is not always on the line of a square deal. If the writers who have had so much to say in the way of criticizing both the name and the registration had given their (supposed) information earlier it would have looked more like a desire to ascertain the truth rather than to reflect on the alleged shortcomings of the registrar.

We have this solution to offer. We suggest that Professor Charles S. Sargent be made the referee in the matter of determining the name. When the hydrangea in question comes into bloom at the Arboretum the Professor could then compare it with the dried specimens in the herbaria and whatever decision Professor Sargent shall render will be eminently satisfactory to us and should be to all concerned.

E. G. Hill

AFTER ADJOURNMENT.

Keep your eye on the Chas. Lamer dahlia. It is "head and shoulders" above anything in its class. As a commercial cut flower subject it will fill a large place.

Let every member of the Carnation Society visiting Washington next week take a look in at the Botanic Garden and doff his hat to the Crittendon Oak and its indomitable defender, Wm. R. Smith.

Don't look for a clean sweep of a houseful of stock as a result of a couple of dollars timidly invested in advertising. Just keep hammering away and be reasonable. It's bound to win.

Hear that heavy rumbling in the distance? That must be old Jupiter and his friend the weather clerk fixing up a howler for Burns' birthday anniversary and the Carnation Society's pilgrimage. Watch out!

That hydrangea problem now takes on new magnitude. Our friend the National Nurseryman opens its columns to it as "the new 'Everblooming!'"

"The worst is not
So long as we can say, 'This is the worst.'"

The warm weather of the past month has been very lenient on the coal pile, and the man with the Electric Circulator on his heating system is to be envied. For warm weather or coldest weather what a comfort that Circulator is to the grower!

We are glad to see the double-flowering lobelia coming into this market at last. It is one of the grandest pot plant and bedding plant novelties sent out in recent years. It produces no seed but may be propagated easily. The color is a most beautiful blue and it is "bound to take."

At the Chicago meeting of the American Carnation Society, ten years ago preliminary certificates were won by the following varieties: Mrs. Thos. W. Lawson, America, Arbutus, Scarlet Queen; three-year certificates by Empress, Evelina, Argyle, G. H. Crane. How fleeting is fame! Wonder where our present day beauties will be ten years hence.

On McKinley Day, January 29, it is proposed to give away a lot of carnations at the exhibition in Washington, and request is made for donations for this purpose from growers. Carnations are plentiful and we hope the growers will do the generous thing. The McKinley sentiment has been worth a good deal to the carnation in its haste for popularity.

I think HORTICULTURE should be complimented on several points but especially on the fact that its columns are not occupied by the effusions of personal spite and spleen, under the imaginary disguise of "wit" such as can be found in some other trade papers. Respectfully yours,

PATRICK FLANAGAN.

New Rochelle, N. Y., Jan. 6, 1908.

PERSONAL.

Detroit visitor: Mr. J. E. Roiser, of New York.

F. E. Palmer, florist, of Brookline, Mass., has been elected president of the Brookline Business Men's Association.

Parker Thayer Barnes, formerly connected with the Garden Magazine, has taken a position with Suburban Life.

Charles A. Davis, of Dover, N. H., who has been ill for three weeks with grippe and pneumonia, is now reported as improving.

Edwin Lonsdale is in attendance upon the meeting of the State Board of Agriculture, of which he is a member, at Harrisburg, Pa.

Visitors in Boston: A. N. Pierson, Cromwell, Conn.; S. S. Skidelsky, Philadelphia; Winfried Rolker, New York; H. R. Mitchell, Waterville, Me.; E. J. Harmon, Portland, Me.

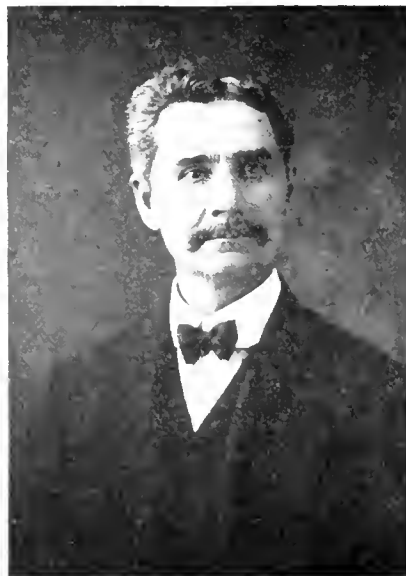

DAVID F. ROY

Richard Engelman, florist, of Pittsfield, Mass., was married to Miss Margaret Wallner, of New York, on January 5, in the German Lutheran Church, New York.

Miss Amy K. Luffman, daughter of George E. Luffman, landscape gardener of Birmingham, Ala., and Mr. Jas. R. Lambly were married at Spokane, Washington, on January 18, 1908.

H. J. Corfield, who for the past three years has been designing and constructing a large estate nearly three hundred acres in extent, near Detroit, has resigned and will return east.

Carl E. Kern, formerly with J. H. Troy of The Rosary Flower Company, New York, has been appointed head of the landscape department of the National Cash Register Company at Dayton, O.

David F. Roy, for many years head gardener at the Converse Estate and superintendent of Pine Banks Park, Malden, Mass., has resigned those posi-

tions and will take charge of "The Moorings." Col. H. E. Converse's estate at Marion, Mass. Mr. Roy's removal from the Boston district will be a decided loss to the gardening fraternity of the New England metropolis who have recognized in him one of the most skilful of the growers and exhibitors at the Massachusetts Horticultural Society's shows. The place he is about to take charge of is practically new and offers abundant scope for constructive ability. A range of greenhouses will eventually be erected. The best wishes of a host of friends will accompany Mr. Roy and his family to their new home.

LADIES' SOCIETY OF AMERICAN FLORISTS.

All members of the Ladies' Society of American Florists attending the carnation meeting at Washington, please wear your Badge Pin.

MRS. W. J. VESEY, Pres.

MRS. CHAS. H. MAYNARD, Sec'y.

OBITUARY.

William Adams, a highly esteemed florist of Great Neck, N. Y., died on January 2.

Frances E., wife of J. E. Linfoot, florist of Cincinnati, passed away on January 11.

Wm. Cunningham, florist, of Cincinnati, O., who has occupied a stand in the flower market since it was started, died on January 12.

Robert Mann, one of the pioneer florists of Lansing, Mich., died on January 6, aged 77. A wife, two daughters and two sons survive him.

Jacob Katz, a retired landscape gardener and florist of Mt. Airy, Pa., died on January 11. He was born in Philadelphia 75 years ago. Two sons survive.

James W. Davis, born in Godfrey township, Ill., where he has spent his entire life, passed away on January 13, aged 67. He has been very successful in raising and propagating small fruits.

Patrick McDonough, who has carried on a florist business in Kearny and Arlington, N. J., for many years, died at his home in East Newark on January 12. A widow, two sons and a daughter survive him.

Mayor Hibbard has put his official ban upon the use of the potted plants and floral decorations from the municipal conservatories for private social affairs throughout the city of Boston.

The mayor was called upon by a committee of young people who wanted to borrow potted plants from the city's conservatories, and he was amazed at such a request. When informed that it was customary for years to secure such displays for the asking, he immediately notified those in charge of the municipal conservatories not to loan any more flowers or potted plants for private use.

In years gone by and until the present administration it was a very common occurrence for the city to distribute plants at halls where social affairs were being held, and the city paid for all the carting. Reform is surely under way.

AMERICAN CARNATION SOCIETY.

The Sixteenth Annual Meeting and Exhibition of this Society will be held in the National Rifles' Hall, 918 G street, N. W., Washington, D. C., January 28, 29 and 30, 1908. Exhibition on the first floor, sessions on the second floor. Address all exhibits to Chas. McCauley, Washington, D. C. Express charges on all exhibits must be prepaid.

Papers will be read as follows: "Experiments in Carnation Growing by the Department of Agriculture," by Dr. B. T. Galloway, Washington, D. C.; "Carnation Breeding," by Prof. J. B. Norton, Washington, D. C.; "What the buyer of a New Carnation should expect from The Originator," by S. S. Skidelsky, Philadelphia, Pa.; "What The Originator of a New Carnation should expect of the buyer" by W. N. Rudd, Mt. Greenwood, Ill.; "Special Points on Carnation Hybridizing," by Peter Fisher, Ems, Mass.; C. W. Ward, Queens, N. Y.; Fred Dornier, LaFayette, Ind., and Richard Witterstaetter, Cincinnati, O.; "Cultural Methods for Carnations," by Irving Gingrich, South Bend, Ind.

Exhibition Schedule.

Class A.—Open to all varieties, Seedlings or Standard Sorts:—

No.	100 Blooms	First Prize.	Second Prize.
1.	White	\$10.00	\$6.00
2.	Enchantress shade of Pink	10.00	6.00
3.	Lawson shade of Pink	10.00	6.00



FRED H. LEMON
President American Carnation Society

4.	Winsor shade of Pink	10.00	6.00
5.	Scarlet	10.00	6.00
6.	Crimson	10.00	6.00
7.	Yellow Variegated	10.00	6.00
8.	White Variegated	10.00	6.00
9.	Any other color	10.00	6.00

Class B.—Open to all varieties disseminated prior to July 1st, 1907:—

Classes No. 10 to No. 36, each for a first prize of \$5.00, and second prize of \$3.00 for fifty blooms of the following varieties respectively: Lady Bountiful, White Perfection, Any other White, Enchantress, Any other Enchantress shade of Pink, Winsor, Pink Enchantress, Any other Pink (this shade), Lawson, Aristocrat, Pink Imperial, Any other Dark Pink, Robert Craig, Red Chief, Victory, Beacon, Any other Scarlet, M. A. Patten, Imperial, Any other White Variegated, Harry Fenn, Harlowarden, Any other Crimson, Eldorado, Any other Yellow Variegated, Prosperity, Any other color. Three prizes may be awarded under No. 36.

Class C.—A gold medal will be given for the best vase of 100 blooms, any variety, any color.

A silver medal will be given for the second best vase of 100 blooms, any variety, any color.

A bronze medal will be given for the third best vase of 100 blooms, any variety, any color.

S. A. F. Medals.

Class D.—A silver medal will be awarded for the best vase of 50 blooms of carnations not yet disseminated.

A bronze medal will be given for the second best vase of 50 blooms of carnations not yet disseminated.

The variety to be in all cases of American origin.

Judges are to reserve awards in this class if in their opinion the exhibits are not worthy of the medals.

The Henry F. Michell Co., Philadelphia, Pa., offer a silver vase valued at \$40.00 for the best 100 blooms of carnation in four varieties, twenty-five blooms to a variety. Open to private gardeners only.

Peter Bisset, Washington, D. C., offers \$10.00 in gold for the best display of carnations grown by a private gardener, distinct from Michell's prize.

Peter Fisher, E111's, Mass., offers prizes for the best 50 blooms of Beacon: 1st, \$12.00; 2nd, \$8.00; 3rd, \$5.00.

Geo. H. Cooke, Washington, D. C., offers \$10.00 in gold for the best 25 blooms pink seedlings or sport darker than Enchantress and lighter than Lawson, never before winning a prize or medal. Those having a preliminary certificate eligible.

Entries for this prize will not be eligible to compete for any other prize.

Geo. C. Shafter, Washington, D. C., offers \$10.00 in gold for the best vase



A. M. HILL
Secretary



PETER BISSET
Vice-President

of 50 blooms, not more than three varieties, open only to growers having less than 20,000 feet of glass.

S. C. Briggs, Washington, D. C., offers \$10.00 in gold for best vase of white carnations, 50 blooms, distinct from other entries.

J. J. Harty, Washington, D. C., offers a silver cup to the exhibitor making the largest display—all vases in all classes being counted as part of this display.

Z. D. Blackistone, Washington, D. C., offers \$10.00 in gold for the best 50 blooms of white carnations, distinct from other entries.

C. A. Goldsmith, jeweler, Washington, D. C., offers a cup or stein for the best 50 blooms of red—new or standard variety. Vases for this prize not to be entered in any other class. Red meaning Beacon, Victory or Craig shade of red.

In addition to the premiums offered in the Premium List the Berry & Whitmore Co. offer a silver cup for the best vase fifty blooms of light pink (Enchantress shade), either novelty or standard sort, but separate from other exhibits.

W. J. Vonderheide offers a very fine silver cup for a vase of 100 blooms of the best carnation to be disseminated for 1908. This exhibit must also be separate from all others excepting that it can enter for Certificate of Merit with the same vase.

In consideration of the lateness in offering these prizes they can be entered for at the meeting in Washington without extra charge. Any one not a member of the society and not acquainted with the rules and regulations can by joining at the meeting, make entries for the show free of charge. Members who have neglected to send in their entries or have additions to make can make them at the meeting by paying \$1.00 for each entry made. Everything possible will be done to make the work of exhibitors easy and expeditious. We have a fine lot of entries now and want more for the above prizes and any other of the

HOUSE OF CARNATION AFTERGLOW.



The illustration shows a house of carnation Afterglow that was planted on August 8th and photographed seven weeks later. These plants were propagated the first week in April, potted

in 2-1/4-inch pots on May 10th and planted in the field on June 2d. The blooms could be cut with stems ten to fourteen inches long at the time the photograph was taken.

numerous ones offered in the Premium List.

Any mail sent the secretary after this issue of the paper to be sure of reaching him should be sent to the Raleigh, Washington, D. C.

Transportation.

Concerning reduced rates to Washington, the Central Passenger Association, having refused the special rate, thus cutting out the States of Ohio, Indiana, Michigan and Illinois, members from these states will do well to buy to Pittsburgh and from there buy

to Washington on the Certificate plan, or get special rates for parties of ten to Washington.

Mississippi, Alabama, Georgia, Florida, South and North Carolina, Tennessee, Kentucky, Virginia, West Virginia, Maryland, Delaware, New Jersey, Pennsylvania, except the northwest corner north and west of Pittsburgh and west of Franklin, Oil City and Warren, New York excepting the territory west of Salamanca and Buffalo, Connecticut, Rhode Island, Massachusetts, Vermont, New Hampshire and Maine, will issue certificates if asked for, making the rate one and one-third.

Through some misunderstanding the New England Passenger Association instructed their agents to issue certificates for the Breeders' Association to be held in Washington, D. C., Jan. 28th to 30th, in conjunction with this society, but failed to add that certificates should be issued to either the Breeders' or the Carnation Society as both are to be counted as one meeting. This has been changed and covers the whole of the New England Association except that the Eastern Steamship Co. certificates will be issued for the Carnation Society in this territory the same as in previous years.

If you cannot get a certificate for the Carnation Society and the agent has instructions to issue for the Breeders' meeting buy your ticket for that meeting; it will be honored in Washington and you can get the reduced fare to return home.

We want everybody interested in carnations to come to this meeting and if possible bring along an exhibit. You will be getting into good company both in the exhibition hall and the meeting room.

ALBERT M. HERR, Sec.



H. W. FIELD'S NEW CARNATION, PRESIDENT SLEVE



GEORGE H. COOK



F. H. KRAMER



J. R. FREEMAN



W. R. SMITH

A Group of
WASHINGTON'S
Busy Men
who will extend
GREETING



E. A. MOSELY

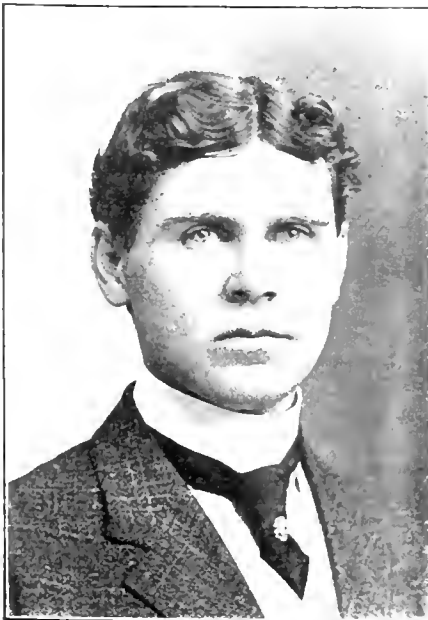

Z. D. BLACKSTONE



WM. F. GUDE



W. H. ERNEST

THREE PROMISING CARNATIONS.

Growers of carnations would find much to interest them at the establishment of James D. Cockcroft, Northport, L. I., one of the largest plants devoted exclusively to the cultivation of carnations east of New York. Besides the best of the standard varieties the principal attractions are the three new varieties, Harvard (crimson), Faust (scarlet) and Georgia (fringed white), originated by Mr. Cockcroft.

The following extract from a letter from one of the leading wholesale florists of New York shows the popularity and ready sale of these novelties:

"Georgia we consider to be the best white carnation coming to New York and can easily sell from 50 to 100 per cent more than regular white.

"Harvard we think to be the best dark red coming here; easier to sell at double the price of any other dark red.

"Yours truly,

(Signed) "TRAENDLY & SCHENCK."

Harvard.

This new crimson carnation originated four years ago. The raisers inform us that it is the result of a cross between Prosperity and Gen. Macco, combining the magnificent size and stem of the former with the freedom and rapid growth of the latter, the flowers measuring from 3 1/2 to 4 inches in diameter, being symmetrical and well built and splendid keepers and shippers. A critical examination by a disinterested party just before Christmas of the 5000 plants now being grown disclosed not a single case of split calyx. The stems are stiff and wiry at all seasons, averaging about 24

inches in length. The plant comes into bloom early and, continuing throughout the season, every shoot produces a well-formed flower.

Faust.

This scarlet variety is a shade brighter than Victory with wiry stems averaging 20 to 24 inches. The flowers are of medium size, well built up, with a perfect calyx. It is a strong grower, coming into bloom very early and its extreme productiveness recommends it

for commercial use, especially as at Christmas it is in full crop.

Georgia.

Among the whites on the market Georgia stands in a class by itself as a commercial variety in productiveness, and a fancy in size, fragrance and form. This variety James D. Cockcroft intends to introduce next year.

CARNATIONS IN NEW BEDFORD.

A. B. Hathaway writes us that carnation crops have been very fine about New Bedford, Mass., this season. Winsor, grown by its originator, Peter Murray, has made a new record. The Lloyd, H. A. Jahn's new white, has created a sensation, the cut from 10,000 plants just before Christmas being very heavy and the flowers averaging over three inches in diameter. S. S. Peckham, who has now given up the retail trade, E. Y. Pierce and R. U. Woodhouse, are all large growers of carnations in this neighborhood, the Queen and Fair Maid being the varieties most extensively grown but it is in the air that the Lloyd bids fair to distance all other whites in their future plantings.

WHITE FAIR MAID.

This pure white sport of the useful and universally popular pink Fair Maid, which forms the subject of our frontispiece, originated with R. E. Moir, and is being disseminated by Welch Bros., Boston. It needs no introduction; the picture shows what it is and the experienced commercial grower will have no trouble in recognizing the brand.



HARVARD



A VASE OF GEORGIA

HOME PRODUCTION OF LILY BULBS.

Bulletin No. 120 of the Bureau of Plant Industry, written by Geo. W. Oliver, treats on the Production of "Easter" Lily Bulbs in the United States. Disease in bulbs imported from Bermuda is given as the reason for the trials which have been under way in the Department of Agriculture to find favorable locations and climatic conditions for the domestic production of these bulbs for commercial purposes. After many unsatisfactory attempts in the Carolinas, on the Pacific coast and elsewhere, it is stated that the experimenters became convinced that the progeny of crossed varieties were more vigorous than either parent, and the work is now being prosecuted in California with results so encouraging that several practical men are engaged in getting up a stock of seedlings upon a large scale. The report now issued tells of the advantages or drawbacks of many localities, the difficulties encountered in the various stages of production, etc. It is stated that the best success thus far has been with seedlings obtained by crossing the red-stemmed "giganteum" with the Harrisii. Full details of culture, selection of seed bearers, preparation of soil, sowing seed, temperatures and their effects, etc., and an interesting group of plates is appended.

APPRAISERS' DECISIONS.

No. 17885.—Iris Bulbs.—Protest 255-184 of F. B. Vandegrift & Co. (New York).

Dried iris bulbs which were classified under the provision in paragraph 251, tariff act of 1897, for "bulbs * * * which are cultivated for their flowers," are claimed to be free of duty under paragraph 548 as "drugs," or under other provisions of the free list. Assessment affirmed.

Waite, General Appraiser: * * * The iris is a well-known flowering plant. See "Iris," International Encyclopedia. From some varieties of this plant is produced the orris root, known to the drug trade. We think, however, that the orris root of commerce is the root of the iris plant after being scraped and prepared for the trade, which destroys the germinating principle. We are unable to learn that the root in such form as imported in this case is known or dealt in by the drug trade. There is some evidence in the case which tends to show that this particular importation was brought in for the purpose of planting and raising the orris root for medicinal or drug purposes of planting and raising the orris root for medicinal or drug purposes. We do not think, however, that the use of the merchandise after importation should govern. It will be noted that the language of paragraph 251 is, "which are cultivated for their flowers." We think the iris roots are cultivated for their flowers, and the fact that they may be diverted to another use cannot vary the assessment upon importation, the commodity not being in shape or condition to be used as a drug or by those dealing in druggists' materials. It appears from the evidence that these plants at the time of importation were in a condition to germinate and grow. If the bulb may be used either to plant for flowering

CARNATION ANDREW CARNEGIE.

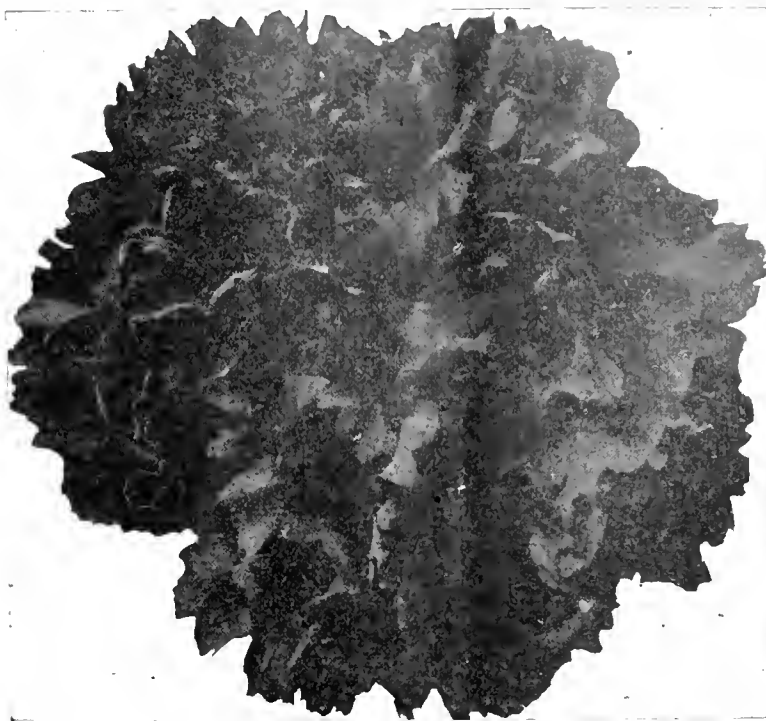

The Chicago Carnation Company has 10,000 plants of this new variety growing. It is even more vigorous than its parent, with a somewhat heavier stem and a shorter growth than Harlowarden. As Harlowarden is so well known universally and has so many good points, there is little left to be said in regard to the merits of this sport. The disseminators are booked up on orders for about all they can deliver this month, and anticipate quite a demand for it later in the season, which they hope to be

able to supply, as the variety makes so many cuttings.

purposes or to raise a product intended for ultimate conversion into a drug, it cannot be said, therefore, to be dutiable under paragraph 548.

A NEW NURSERY.

Messrs. A. Van Leeuwen and H. H. deWildt, formerly of Worcester, Mass., under the firm name of the Horticultural Company, have put in operation a nursery of 50 acres on the tract which the Carolina Trucking Development Company is developing at Castle, N. C.

The Horticultural Company is at present erecting a large stable and bulb house, 40x100 feet, on their place at Castle Haynes. Both gentlemen are well qualified by long experience in nursery work and landscape planting,

AN INTERESTING SEEDLING.

Edwin Lonsdale of Girard College, Philadelphia, has a number of seedling carnations one of which, a cross between Enchantress and Crane, he has great hopes of. It has the characteristic stem of the seed parent and gives promise of being a more profuse bloomer. The shape of the flower is also an improvement. It is essentially a white variety but has the faintest pink edge on each petal which, however, fades away before the flower is in condition for cutting. Mr. Lonsdale has hopes that this pink edge is the beginning of the picotee marking which, in his opinion, is preferable to the striped or bizarre stripe of variegation which, thus far, prevails in the American carnation type.

NEWS OF THE CLUBS AND SOCIETIES.

NEWPORT HORTICULTURAL SOCIETY.

A largely attended meeting of the Newport Horticultural Society was held in Mercury Hall, Tuesday evening, Jan. 14. D. J. Coughlin for the ball committee reported everything very satisfactory and promising for a large surplus of cash when all bills are paid. The committee were awarded a vote of thanks. Quite an interesting discussion was started by Mr. MacLellan on the subject of plant registration by the S. A. F. In the course of Mr. MacLellan's remarks he said that while he did not agree that the Secretary of the S. A. F. should be blamed for any mistakes occurring which he could not have prevented, (if such were the case that mistakes were made,) still he was strongly of the opinion that the S. A. F. should place more safeguards around the registry in order that only names of new varieties which, after investigation by persons of qualifications for the work, could be guaranteed as such, would be registered. It was generally conceded that the proper registry of new varieties of plants is a necessity. A case in point was mentioned where an amaryllis long known to gardeners and grown by them under a certain name is now advertised as something new, though not under the name it was known by. By such methods persons are liable to be disappointed in what they buy. Mr. MacLellan will read a paper at the next meeting of the society.

AMERICAN BREEDERS' ASSOCIATION.

The fourth annual meeting of this association will be held on January 28-30 at National Rifles Hall, Washington, D. C. On Wednesday and Thursday from 2 to 5 P. M. the meetings will be held conjointly with the American Carnation Society, and papers will be presented as follows:

Wednesday, Original Work among Native Roses, by W. Van Fleet, Little Silver, N. J.; Some Observations in Plant Improvement, by A. M. Soule, Athens, Ga.; Report of Committee on Breeding Roses, Peter Bisset, Washington; Development of the Immune or Resistant Character in Plants, by H. L. Bolley, Fargo, N. D.; Report of Committee on Breeding Carnations, C. W. Ward, Queens, N. Y. On Thursday afternoon papers on Carnation Breeding will be read and discussed.

ENGELMAN BOTANICAL CLUB.

The Engelman Botanical Club, St. Louis, Mo., held its meeting on January 13, and officers for 1908 were elected as follows: C. H. Thompson, president; Drs. Green and Gladfelter, vice-presidents; H. S. Barber, secretary; John Kellog, treasurer. The meeting was well attended and there were some very entertaining features during the evening, one of the best being a lecture by Prof. M. Craig, who has charge of the herbarium at the Missouri Botanical Garden. The next meeting will take place February 10th. Anyone interested is welcome.

NEW HAVEN COUNTY (CONN.) HORTICULTURAL SOCIETY.

The regular meeting of the above society was held on Tuesday, the 7th inst. Officers for the ensuing year were elected as follows: John H. Murray, president; Frank Duffy, vice-president; David Kydd, treasurer; Walter Koella, secretary; board of managers, James Moore, Robert Paton, Thos. Pettit, James Bruce, Ernest Carroi. The new president gave a short address outlining the work for the following year. A syllabus of speakers on various subjects to be presented at different meetings is being prepared. It was voted to have the annual chrysanthemum show again next November.



LEONARD KILL

The New President of the Chicago Florists' Club.

Our congratulations to the Chicago Florists' Club on its good selection of a president for this all important year in its history. Leonard Kill is young, wide-awake and popular. He will "make good."

DETROIT FLORISTS' CLUB.

The many members of the club who assembled at the last regular meeting were doomed to disappointment. The special committee to decide whether there should be a spring or fall show recommended a fall show, but after a lengthy discussion the matter was referred back to the committee for further consideration.

MINNESOTA CROP BREEDERS.

The afternoon session of the State Agricultural Society Jan. 15 was given over to the Crop Breeders' Association. Among other interesting papers on field crop breeding was one on potatoes by F. M. Libby and one on growing onions by F. H. Gibbs, both well-qualified, up-to-date growers of vegetables.

GARDENERS' AND FLORISTS' CLUB OF BOSTON.

The meeting of the Gardeners' and Florists' Club at Horticultural Hall, Boston, on the evening of January 21, was a record breaker. It was ladies' night and there must have been close to four hundred members with their ladies in attendance. More or less routine work was transacted briefly before the entertainment began. The secretary made the interesting statement that the largest attendance during the year 1907 was 316 and the smallest 110, the average being 153. Sixty-three new members had been added. The next meeting, in February, will be carnation night and the March meeting will be rose night. The report of the treasurer showed a gain of \$200 in the treasury for the year. Resolutions on the deaths of W. W. Edgar and John Clark were adopted and placed on record. An appreciative letter was received from John Cook concerning the award given at the last meeting to his rose My Maryland. A letter of gratitude came from John Clark and Wm. S. Clark of Washington. On the exhibition table were some superb trusses of geranium from W. N. Craig, eucharis flowers from F. W. Fletcher and Moschosma riparium from David Weir.

Among the speakers during the evening were S. S. Skidelsky of Philadelphia, J. K. M. L. Farquhar and Thos. J. Grey, all of whom struck an optimistic note and gave much pleasure with their remarks. The musical program rendered by kind friends of the members gave unalloyed pleasure and the refreshments so lavishly handed around by volunteer young ladies and gentlemen appropriately closed an evening which will be long remembered as one of the most enjoyable occasions in the history of this popular organization. Among the performers were Frank Cannell, Mrs. Whittet, Miss Hanigan, Mrs. and Mr. Brough.

With Boston's big department store show windows all aglow with tartans and Black Watch kilts in honor of the 149th birthday of Scotland's beloved poet, it seemed perfectly natural and fitting that a goodly proportion of the music should find its best expression through the exultant strains of "Bonnie Dundee," "The March of the Cameron Men," and the love cadences of the land of heather and bonnie lasses. But "Killarney" and "Barney O'Hay" also had a hearing, and so for everybody.

"The golden hours on angel wings flew—"

GREENWICH GARDENERS' SOCIETY.

The Greenwich Gardeners' Society held a meeting at Florist McMellen's store, 67 Arch street, Greenwich, Conn., to elect officers for the ensuing year. All the old officers were re-elected. President, Silas Frost; vice-president, P. Flaherty; financial secretary, P. Crighton; treasurer, A. Mead; recording secretary, T. Young. After the routine business had been discussed the meeting adjourned till Feb. 5.

THOMAS YOUNG, Secretary.

New Rose-MRS. JARDINE

Has all the good qualities and is a money maker.

Easy to Grow. Large Flower. Free Bloomer. Fragrant.

It has stood every test and already has been awarded many honors.

A Silver Medal from Massachusetts Horticultural Society. A Silver Medal from the Pennsylvania Horticultural Society. And Numerous Certificates.

It has also stood the best test that any novelty could possibly have in receiving the highest honors of the award committee of the New York Florist Club after their exhaustive examination of the growing plants in December, they having unanimously awarded Mrs. Jardine the club certificate with a score of ninety-two points.

Our young stock is in superb condition and all orders will be filled in strict rotation on and after March 15th.

From two and one half inch pots, \$6.00 per dozen; \$30.00 per hundred; \$250 per thousand, \$1125 five thousand.

Grafted plants on DICKSON'S MANETTI STOCKS, \$5.00 per 100 additional.

Send orders to

ROBERT SCOTT & SON

Sharon Hill, Pa.

OR

WILLIAM P. CRAIG

1305 Filbert St., Philadelphia, Pa.

Sole Selling Agent in United States and Canada

SOUTHAMPTON HORTICULTURAL SOCIETY.

At the second bi-monthly meeting of this society held January 16, C. Gollioz read a very interesting paper on Mushroom Culture which brought out a good discussion. The subject of mulching newly planted trees was taken up and discussed at some length after which Pres. Clark appointed a show committee as follows: U. G. Ager, J. Guilfoyle, M. McLaughlin, Wm. Fitzpatrick, B. C. Palmer and Wm. Griffin. U. G. AGER.

GINSENG GROWERS.

The following officers were elected January 15 by the Minnesota State Ginseng Growers' Association: President, J. S. Reese, Hutchinson; 1st vice-president, H. D. Lots, St. Paul; 2nd vice-president, E. H. Peterson, Garden City; secretary, Mrs. D. D. Chapin, Hutchinson; treasurer, C. R. Klinkenberg, Lester Prairie.

Only seventeen growers of the State belong to the association, but they are determined to better the condition and to stop the growing of Japanese Ginseng which they claim is inferior to American. This organization is only a year old, but is thriving.

SOCIETY OF AMERICAN FLORISTS AND ORNAMENTAL HORTICULTURISTS.

President Traendly has appointed as State vice-presidents for Michigan: Messrs. A. Pochelon, Detroit, and Henry Smith, Grand Rapids, for 1908.

FLORISTS' CLUB OF WASHINGTON.

A special meeting was held at Gude's Hall, Jan. 21st, for the purpose of settling all final matters pertaining to the approaching carnation show. There is every reason to believe that the exhibition will outdistance all other shows of this city. On the evening of Jan. 29th, which is "McKinley Day," all the carnations will be given away, and growers are earnestly requested to donate what carnations they can to help make the undertaking a thorough success in every way.

The reception to be held on the evening of the 30th will be at Rauscher's. F. H. Kramer was appointed chairman of committee with the power of appointing six colleagues of his own selection. The committee on banquet hall decoration is headed by Wm. F. Gude, who will also select his own committee. Chas. McCauley was appointed superintendent of exhibition. All exhibition tables must be below the usual average in order that the exhibits may be better seen and be more effective. Letters were read from both Commissioner McFarland and Secretary Wilson declining with regret their invitations to be present at the banquet, pleading previous engagements.

The next regular meeting of the club will be held Feb. 4th and will be especially important, as it is the meeting for the election of officers for the coming year.

AMERICAN ROSE SOCIETY.

F. R. Pierson Co., Tarrytown, New York, offer a silver cup for a vase of twelve blooms (or not to exceed twenty-five) for the best new rose not in commerce and never before exhibited before the American Rose Society.

BENJ. HAMMOND, Secretary.

CLUB AND SOCIETY NOTES.

On Thursday, January 30, C. A. Morton of Marlboro will speak on Children's Home Gardens before the Worcester County Horticultural Society, Worcester, Mass.

The lecture before the Massachusetts Horticultural Society, Boston, on January 25, will be delivered by Robert Cameron of Cambridge; subject, Annuals and Biennials.

At the annual election of officers on January 15th at Providence the Rhode Island Horticultural Society elected E. H. Burlingame, president, and Chas. W. Smith secretary and treasurer.

The State Horticultural Association held its annual meeting at Lancaster, Pa., January 13-14. Among the interesting features was an illustrated lecture depicting insect warfare by Prof. Surface of Harrisburg.

The St. Louis Horticultural Society at its last meeting decided to again hold a Spring Flower Show, place and date not yet decided upon. The executive committee will meet again next month to make arrangements.

The Tennessee State Nurserymen's

Special Announcement

by the

S. S. PENNOCK-MEEHAN CO., of Philadelphia

The Sensational New Rose, MRS. JARDINE

If anyone is in a position to know and judge of the merits of a new rose from a commercial point of view, it is the wholesaler. He stands midway between the grower and retailer, and knows thoroughly how difficult it is to get a rose to suit both. Therefore, when a firm of the standing of the S. S. Pennock-Meehan Co. comes out boldly and says that Mrs. Jardine is a winner in every way, after they have watched her behavior long and carefully, every grower may confidently bank on their assurance. The important place long held by Bride-maid and now occupied for a short time by Killarney is the destined pedestal of Mrs. Jardine in the rose world. Nothing less. Orders booked now with the S. S. Pennock-Meehan Co. will be filled direct from their growers, delivery commencing March 15, strong plants on their own roots, 2½ inch pots, as follows:— **\$30.00 per 100, \$250.00 per 1000.**

In view of the enormous demand already in evidence from all parts of the country, orders should be placed without delay. If grafted plants are preferred, these can be furnished at fifty dollars per thousand additional—grown on the genuine Dickson Manetti Stocks.

Association will meet on January 31, at the Tulane Hotel, Nashville. An interesting program has been arranged. Exhibits of spraying machinery, insecticides, nursery stock, etc., will be made.

The fifth annual meeting of the Alabama State Horticultural Society will be held at Birmingham on February 13-14. Prof. S. B. Green, of Minnesota, is expected to be present. W. F. Heikes is president and R. S. Mackintosh, secretary.

The Horticultural Society of Chicago at its meeting on January 14 elected officers as follows: President, W. E. Kelley; vice-presidents, W. N. Rudd, Ernest Wienhoeber, N. H. Carpenter; secretary, E. A. Kanst; treasurer, E. Wienhoeber. One thousand dollars was pledged to the guarantee fund for the National Flower Show and prizes and medals to the value of \$500.

At the meeting of the Illinois Florists' Association which meets at Springfield, Ill., Feb. 18 and 19, quite a delegation of members of the St. Louis Florists' Club are expected to attend. Ex-President H. C. Irish of the St. Louis Florists' Club has accepted the invitation to read a paper. The request came from President Hey of the Springfield Florists' Club. Mr. Irish has not as yet selected his subject, but it is sure to be interesting to all.

The prize list of the Victoria Horticultural Society, Victoria, B. C., for their show on August 12-13, is now ready and includes some one hundred and seventy prizes. In the sweet pea class are offered a vase valued at \$20 and the silver medal of the National Sweet Pea Society; Robert Sydenham, of England, offers three prizes of a guinea, 15s., and 10s. 6d., respectively, for sweet peas grown from seed furnished by him. In the decorated dinner table class the prizes are \$25, \$12 and \$6, respectively.

The annual meeting, banquet and exhibition of the State Florists' Association of Indiana was held January 15 at Indianapolis. It was decided to extend an invitation to the American Carnation Society to hold its annual convention and exhibition at Indianapolis in 1909. Officers for the ensuing year were elected as follows: President, A. S. Stewart, Anderson; vice-presidents, Herman Young, Indian-

Rooted Carnation Cuttings

Ready Now, from Sand and Soil

Lawson.....	\$2.00 per 100
White Lawson.....	2.50 "
Red Lawson.....	2.50 "
Harlowarden.....	2.50 "
Enchantress.....	2.50 "
Lady Bountiful.....	2.50 "
Rose-Pink Enchantr's	3.00 "
Victory.....	3.00 "
White Perfection.....	3.00 "

H. N. HOFFMAN, Elmira, N. Y.

apolis; Chas. Knopf, Richmond; secretary, A. F. J. Baur, Indianapolis; treasurer, H. L. Wiegand, Indianapolis.

NEW FORESTER AT IOWA STATE COLLEGE.

At a recent meeting of the Board of Trustees of the Iowa State College, Mr. C. A. Scott, of the United States Forest Service, was elected to the Chair of Forestry to fill the vacancy caused by the resignation of Professor H. P. Baker who accepted a more lucrative position at the Pennsylvania State College. Mr. Scott is a graduate of the Kansas State Agricultural College and a student of the Yale College of Forestry. Mr. Scott has been continuously in the employment of the Forest Service since graduation, and during this period of seven years has gradually advanced through all stages of the work from that of Student Assistant to Forest Supervisor, which position he resigned to accept the Chair of Forestry at the Iowa State College.

His work has been largely confined to the Middle West and the Rocky Mountain states; hence he has the advantage of being familiar with the forestry conditions of the Upper Mississippi Valley. Since its origin he has had charge of the extensive forest nurseries and plantings of the Dismal River National Forest. During the past three years he has given a special course of lectures before the Nebraska University forestry students and during the winters has also rendered assistance as a lecturer at the Farmers' Institutes of Nebraska. In 1906 he was elected to membership in the Society of American Foresters, a professional organization which is limited in its membership. His training, experience, strength of character and personality make him one of the best men available for the position to which he has been elected at the Iowa State College.

BOTANIC GARDENS AND THEIR USE.

At a meeting of the horticultural seminar at Massachusetts Agricultural College, January 17, A. S. Kinney of Mount Holyoke College gave a valuable paper on Botanic Gardens and Their Uses in Teaching Horticulture. He pointed out the difference between a flower garden and a botanic garden saying that it was just the difference between a novel and a spelling book. The same words may be in each book but in one they are arranged for beauty of effect while in the other they are arranged systematically for study. In growing plants in a botanic garden it is important that each species be allowed an opportunity for perfectly normal development. No group of plants should be especially favored and none should be placed at a special disadvantage. Labels should be of two kinds, large genus labels and smaller species labels. It is often advisable to take in all of the labels during the winter and it is nearly always best to take in the smaller ones. A record of plants in the gardens should be kept either in a record book or better still in a card catalog. As fast as plants disappear in the collection the cards representing them should be placed in a separate file thus maintaining a dead list. When a species disappears in this manner a careful entry should be made on the card showing how and why it was lost. It is desirable in a botanic garden to have representations of all families and as far as possible of all important genera. It requires considerable study and enterprise to secure a complete representation. Herbaceous perennials are especially valuable because they are easily maintained and they add greatly to any botanic collection. Valuable additions to a botanic garden are to be secured most easily with exchanges with other botanic gardens. Nearly every garden maintains an exchange list of seeds and it is easy in this way to secure new plants from all parts of the world. The uses of the botanic garden are various. The opportunity offered for the study of plants in their natural condition is greater than in a flower garden or other ornamental collection.

During Recess

TARRYTOWN HORTICULTURAL SOCIETY.

The ninth annual dinner of this society was held at the Florence Hotel on January 15, 1908. The hall and tables were artistically decorated with carnations from F. R. Pierson Co. and flowering plants from several private gardeners. About sixty-five members and guests were present and after a short address of welcome by newly-elected President Angus, we sat down to the most elaborate dinner given by the caterers, Mr. and Mrs. John Hennessey, and, as far as the writer could see, every one did honor to the repast. Mr. and Mrs. Hennessey are retiring from business this spring, and as it was their last dinner put up for this society they surpassed their record, and as a token of friendship to the members they donated a beautiful gold mounted ivory gavel, which was presented by Hon. Frank V. Millard. Mr. F. R. Pierson responded to the donation in a few well chosen words, and accepted the gift in the name of the society. The jovial Dr. F. E. Russell was toastmaster for the evening, and he certainly filled the position with tact and plenty of good humor. A few representatives of kindred societies were with us, but an early start for home made them miss the best part of the evening. The poetic J. Austin Shaw was present as usual, and we had to listen to some very fine poetry about Tarrytown. S. S. Butterfield made only a flying visit and had to return home early.

Speakers on different subjects as called by the toastmaster were Farmer Millard on "Back Yard Gardens;" Farmer Tibbits on "Aquatic Gardens;" Farmer Ely on "Harrowing Experiences with Automobiles;" Farmer Brown with "Graft and Grafting," all were listened to with pleasure.

It was pronounced the most enjoyable dinner we ever had; and the only regrettable incident of the evening was that one prominent member had the misfortune to have his hat exchanged for a pretty well damaged one; but it seemed to fit his head.

LOUIS A. MARTIN, Cor. Sec.

SPORTY NEW HAVEN.

The bowling team of the New Haven County Horticultural Society held its banquet at the Aschenbroedel on the 15th inst. and presentation of prizes won during the last series of games was part of the program. The following is a list of prize winners and their averages:

	Ave.	High Single.
Ferguson	165	215
Dickie	159	194
Nye (Captain)	152	205
Bell	139	186
Pettit	139	177
Symons	135	172
Wirtz	130	173
W. J. Bayliss	124	189
A. Bayliss	124	176
Kydd	116	159
Bruce	116	157
Webster	108	176
Moore	106	159

Ferguson won silver cup for three high singles; W. J. Bayliss ditto for high average. At the meeting on the 18th, Thos. Nye was re-elected captain.

A committee was appointed to make

DAGATA

In **DAGATA** we have what is conceded, and that without successful contradiction, to be the highest development of the Geranium at the present time, the premier of M. Bruant's many magnificent introductions, which are recognized as the Standard in their different classes the world over. The color is a beautiful shade of mauve rose, with large white blotches at the base of each upper petal, flowers are freely produced in enormous trusses, the habit is perfect. dwarf, robust and branching. **25c each; \$2.00 per dozen; \$15.00 per 100.**

CYCLOPS. This new race of Geraniums is remarkable for their distinct white center, making them strikingly attractive as a pot plant. The following varieties are all of splendid habit of growth, free blooming, etc., and we are confident they will give satisfaction in every way.

MISTRAL. (Lemoine, 1905), the brightest soft crimson shading through tender rose to distinct white center. **\$1.00 per dozen, \$6.00 per 100.**

MAURICE POTTE-HER. (Lemoine, 1905), bright scarlet, shading through tender violet to white center. **\$1.00 per dozen, \$6.00 per 100.**

JULES VASSEUR. (Bruant, 1906), vermillion scarlet, distinct white center, slight violet shading on upper petals. **25c each, \$2.00 per dozen.**

LEON BAUDRIER. (Bruant, 1906), beautiful soft cerise, shading to white center. **25c each, \$2.00 per dozen.**

LEOPOLD BOUILLE. (Bruant, 1906), bright crimson magenta, shading through violet to white center. **25c each, \$2.00 per dozen.**

DR. PHILIPPE TISSOT. (Bruant, 1906), light crimson, shading through magenta to white center. **25c each, \$2.00 per dozen.**

GERANIUMS, New Varieties, 100, all different, 1905 and 1906 introduction, a splendid collection for \$10.00.

GERANIUMS, Standard Varieties, \$2.00 per 100 up. 2-in pots, 1000, our selection in 20 varieties for **\$18.50.**

GERANIUMS, Ivy-leaved, good assortment, \$3.00 per 100.

PELARGONIUMS, 6 good varieties, \$1.50 per dozen, \$6.00 per 100.

Lantanas, 10 varieties.....	\$2.00 per 100	Coleus, 10 var efls.....	\$2.00 per 100
Hardy Chrysanthemums.....	2.00 "	Ageratum, Stella Gurney, Inimitable and Dwarf White.....	2.00 "
Hardy English Ivy.....	2.00 "	Verbenas, white, pink, scarlet and purple.....	2.00 "
Fuchsias, Black Prince and Minnesota.....	2.00 "	Caladium Esculentum, 3 to 6.....	\$1.00
Cuphea, Cigar plant.....	2.00 "	" " 6 to 9.....	2.00
Dahlia roots, \$5.00 per 100, \$40.00 per 1000, whole field clumps; send for list.		Lavender and Rosemary 2-in.....	2.00
		" " 3-in.....	3.00

Visitors always welcome. Cash with order.

R. VINCENT, Jr., & SONS CO.
WHITE MARSH, MD.

RHODODENDRONS, ANDROMEDAS, KALMIAS AND SPECIMEN EVERGREENS

JOHN WATERER & SONS, LD.

AMERICAN NURSERY

BAGSHOT, - - - ENGLAND

up a schedule, as there are about twenty members more in the club and match games will be played every Monday and Saturday night. The Aschenbroedel alleys have been secured for those nights and some fine prizes will be put up.

FUN AT MADISON.

The second annual smoker of the Morris County Gardeners' and Florists' Society, at Madison, N. J., was a gala affair. Over one hundred and fifty members and their friends were on the job.

Great credit is due the entertainment committee for the high class talent they secured. Service of coffee, sandwiches, punch "a la Totty" and cigars was abundant and timely. There was a short business meeting, at which letters of regret were read from the

Monmouth County Horticultural Society, Tarrytown Horticultural Society and Wm. J. Stewart of HORTICULTURE. Among the visitors were Harry Turner of Castle Gould, the Rickards Bros., Wm. Sperling of Stump & Walter, W. E. Marshall, who represented the New York Florists' Club, making an address and singing a couple of songs. J. Austin Shaw, who left his poetry on the train but had a couple of yarns that were worth anyone's while to hear. The indispensable Al. and Billy Rickards helped with their songs and playing. O. A. Miller of the N. J. Floricultural Society extended an invitation to attend their smoker on Feb. 7th, in a body. The invitation was accepted and Orange will hum that evening. "Auld Lang Syne" was sung at 1 A. M.

E. R.

New Rose—MY MARYLAND

Rose Growers in attendance upon the Carnation Show at Washington are invited to stop over at Baltimore and see this rose growing.

I am booking orders now. It is a beautiful salmon pink with long buds. Easy and strong grower. Makes no blind wood, has averaged 22 flowers to a plant since the first of October, has long, stiff stems. Some of the largest growers who have seen it have bought from one to three thousand plants.

PRICE, 2 1-2 inch pots, \$5 per dozen, \$25 per 100, \$200 per 1000.

STOCK LIMITED

JOHN COOK, 318 N. Charles St., Baltimore, Md.

CATALOGUES RECEIVED.

American.

American Horticultural Distributing Co., Martinsburg, W. Va.—Pamphlet of Target Brand Scale Destroyer.

W. W. Barnard Company, Chicago.—Market Gardeners' Price List of high grade vegetable seeds and gardening tools.

Henry Saxton Adams, Wellesley, Mass.—Adams' Little Green Book of Choice Seeds and Bulbs, 1908. Sweet peas for cover subject.

D. McNallie Plant and Fruit Co., Sarexie, Mo.—1908 Catalogue and Price List of Strawberry Plants. 10,000,000 in 75 varieties.

R. Vincent, Jr., & Sons Co., White Marsh, Md.—Wholesale Trade List of Vegetable, Greenhouse and Bedding Plants for Florists and Dealers Only.

California Rose Company, Pomona, Cal.—Illustrated and Descriptive Book of Field Grown Roses. Issued for Fall of 1907 and Spring of 1908. Finely illustrated.

Chicago Carnation Company, Joliet, Ill.—Price List of Carnations and Chrysanthemums for 1908. Portraits of Manager A. T. Pyfer and Supt. Peter Oisem adorn the title page.

W. W. Wilmore, Denver, Colo.—Catalogue of Dahlias, Hardy Herbaceous Plants, etc., for Spring, 1908. Illustrated with excellent portraits of the various types of dahlias, which are Mr. Wilmore's leading specialties. Also Dahlia Trade List.

Bridgeman's Seed Warehouse, Rickards Bros., proprietors, New York City

—Flower and Vegetable Seed Catalogue for 1908. Pretty cover design in gold and drab on brown background. A good sensible publication and very creditable to "the boys."

Joseph Breck & Sons, Boston, Mass.—1908 Catalogue of High Grade Seeds. As usual a comprehensive list, with fine descriptive text and dignified make-up. The cover is white with inscription in soft green tints with delicate scroll work in red.

R. Vincent, Jr., & Sons Co., White Marsh, Md.—Geraniums. A very attractive catalogue, a collection of handsome geranium novelty portraits bound together, all of the highest artistic excellence and well calculated to bring business to the house.

James Smalley & Co., McPherson, Kansas.—Garden and Field Seed Annual, 1908. Golden chrysanthemums and golden corn, with background of brown oak leaves, form a somewhat unusual but effective cover. Kansas' seed interests seem to be well taken care of.

Johnson Seed Company, Philadelphia, Pa.—Garden and Farm Annual, 1908. A robust old gentleman gazing in admiration on a mammoth onion duly larded, calls attention on the cover page to the good things enumerated within. Profusely illustrated with convincing half-tones.

Elmer D. Smith & Co., Adrian, Mich. Wholesale Catalogue for 1908 of Chrysanthemums, New and Standard Varieties. The reader doesn't need to go beyond this catalogue to get in touch with the top crust of the chrysanthe-

num interest in America. Send for it and take your inspiration from it. It fills the bill.

Henry F. Michell Co., Philadelphia, Pa.—Michell's 1908 Book of Seeds. This astute seed merchant has chosen for his front cover illustration a group of hardy chrysanthemums in colors and for the back cover some exquisite dahlias. The novelty list is a good one and the catalogue is altogether up-to-date.

Wm. Elliott & Sons, New York City.—Seeds, 1908. This volume is quite unusual in size and form. The front cover presents a charming garden scene in dainty colors, of trees and shrubs and blooming rhododendrons. Nasturtium Pink Beauty adorns the back cover. One of the handsomest of the season.

Storrs & Harrison Co., Painesville, O.—Spring Catalogue, No. 2, 1908.—Cover subjects are Digitalis and Royal Striped Comet Asters effectively portrayed in colors. This is a book of over 100 pages devoted to greenhouse and hardy plants, seeds, trees and shrubs, and profusely illustrated with half tones and wood cuts.

Fancher Creek Nurseries, Fresno, Cal.—New Products of the Trees; Luther Burbank's Late Introduction. Contains a number of beautifully colored plates of the Vesuvius, Formosa, Gaviota and Santa Rosa plums, Rutland plumeot and finished lumber of the Paradox and Royal Black walnut, the latter a cross between Juglans nigra and J. Californica. The volume contains also portraits of Luther Burbank and Geo. C. Roeding.



ADIANTUM FARLEYENSE

DREER'S MIXED FERNS FOR DISHES

There always has been a scarcity of **First Class Ferns** after the Holidays and in anticipation of this we have this season prepared an extra quantity of both 2 1/4 and 3 inch pot plants which are now in prime condition, better than we have ever been able to supply at this season of the year. We offer

2 1/4 in. pots in choice mixture, \$3.50 per 100; \$30.00 per 1000
 3 " " " " \$6.00 " \$50.00 "

We also have an exceptional fine lot of

Adiantum Farleyense

6 inch pots, fine specimens, \$1.00 each
 8 " " " " \$2.00 "

Nephrolepis Amerpohli

6 inch pans, elegant stock, \$1.00 each

For a complete list of seasonable stock see our **Quarterly Wholesale List** just issued.

HENRY A. DREER

714 Chestnut Street, : PHILADELPHIA

CATALOGUES RECEIVED.

Foreign.

Roustan, Servan & Cie, St. Remy de Provence, France.—Wholesale Catalogue and Price List of flower and vegetable seeds.

Wilhelm Pfitzer, Stuttgart, Germany.—General catalogue of seeds, plants, bulbs, roses, etc., including many choice novelties; also special rose list.

J. Heiß's' Sahne, Halstenbek, Germany.—A little book of views in this busy nursery establishment showing fields of seedling conifers, etc., packing sheds and facilities.

Uberto Hillebrand, Pallanza, Italy.—Wholesale List of Flower, Vegetable and Tree Seeds. Aster alpinus longipetiolata Goliath is a promising novelty from Central Asia.

Frederick Roemer, Quedlinburg, Germany.—Wholesale catalogue of Choice German Flower Seeds. Strong on pansies, stocks, asters and other specialties of this well-known house.

Arpad Muhle, Temesvar, Germany. Rose Catalogue for 1908. A remarkable list of about 1000 varieties of roses in all classes with name of introducer and date of introduction. Many line rose portraits.

K. Velthuys, Hillegom, Holland.—Wholesale Trade List of Holland Bulbs and Flower Roots. A colored view of one of the firm's tulip fields in bloom makes an attractive frontispiece. Importers of French and Dutch bulbs would do well to consult this list.

M. Herb, Naples, Italy.—General Catalogue of Seeds for 1907-1908. The text of this catalogue is given in three languages, English, German and French. Some interesting novelties in myosotis, helianthus, ipomea, stocks, zinnias, etc., are offered.

Henry Mette, Quedlinburg, Germany.—1907-1908 Trade Catalogue of Flower, Vegetable and Farm Seeds. A very full list of the offers of this old-established firm. The cover illustrations in color comprise novelties in petunias, verbenas, tuberous begonias and violas.

F. C. Heinemann, Erfurt, Germany.—Special Trade Offer of Novelties, 1908, and of previous years. Among the interesting things described and figured are pansy 'Eros,' Emperor salpiglossis, Gloxinia Meteor and Dark-shaded Princess pinks, all of which are beautifully shown in a colored plate.

Papet Bergmann, Quedlinburg, Germany.—General seed, bulb and plant catalogue for 1908. The cover is decidedly original, being of terra cotta ground work, with a charming young miss watering a plantation of four-leaved clover with a watering pot of enormous capacity.

Wilhelm Muhle, Temesvar, Germany.—General Catalogue of Seeds, Plants and Shrubs, hardy and tender. An immense book with gorgeous covers, the front showing new rose-flowered canna Mad. Marguerite Muhle, with portrait of the lady in whose honor it was named, and the back page adorned with three strikingly handsome chrysanthemums.

PUBLICATIONS RECEIVED.

The Mulberry and Other Silk Worm Food Plants, by George W. Oliver, is the title of Bulletin No. 119 of the Bureau of Plant Industry, issued Dec. 31, 1907. This is to take the place of Bulletin No. 34, published in 1903, on the same topic, which has long been out of print.

AZALEAS

for fall delivery, the best that are grown, also Palms for spring or fall delivery, furnished by August Haereus, Sommergem, Belgium; orders booked now. Address the American representatives,

AUGUST ROLKER & SONS, New York, 31 Barclay Street, or P. O. Box 752.

ORCHIDS

Largest Importers, Exporters, Growers and Hybridists in the World

Sander, St. Albans, England and 235 Broadway, Room 1 NEW YORK CITY

... ORCHIDS ...

Just in hand, C. Trianae, C. labiata, C. Mossiae, C. Intermedia, C. Schroderae, C. Speciosissima, C. Cirrha, C. Gaskelliana, Laelia anceps, L. Albida, L. majalis, L. Autumnalis, Epidendrum Vittellinum majus, E. Cooperianum, Oncidium Crispum, O. Varicosum, O. Cavendishianum, O. Luridum, Odonto Citrosomum. To arrive in a short time, C. Dowiana, C. Aurea, C. Warmuthii, Miltonia Vexillaria.

CARRILLO & BALDWIN SECAUCUS, N. J.

ORCHIDS

Just arrived, in fine condition.

Cattleya Trianae (new district).
 Oncidium Varicosum Rogersii.

Write for prices.

JOSEPH A. MANDA, 191 Valley Road, WEST ORANGE N. J.

Write at once for our quotations on all

ORCHID IMPORTATIONS

FOR 1908 DELIVERY

JULIUS ROEHRS CO.,

The Orchid Nurseries, Rutherford N. J.

ORCHIDS

We are at present booking orders for freshly imported orchids for delivery 1908, of all leading kinds at reduced prices. We have just received the following:—Oncidium Sarcodes, O. Forbesii, O. Tigrinum and Sophronites, randiolora and Coccinea.

LAGER & HURRELL, Summit, N. J.

ORCHIDS

The largest importation of Orchids ever received in this country WILL ARRIVE next spring from Brazil, Colombia and Venezuela. If you intend putting in stock wait for these to arrive and we will quote the Lowest Prices in America.

ORDONFZ BROS., - Madison, N. J.

In ordering goods please add, "I saw it in HORTICULTURE."

JAPANESE
 THE YOKOHAMA NURSERY CO. NEW YORK.
 31 BARCLAY STR.
LILIES
PLANTS
BAMBOO STAKES

Seed Trade

The very mild open weather is regarded by many as an ill omen for next season's crops. Of course there is yet plenty of time for snow and cold weather. Snow is needed to protect the roots of plants and winter grain as the freezing and thawing is most harmful, but the absence of cold weather is allowing great swarms of insects to become active, and numerous reports of the green bug and Hessian fly in the winter wheat are floating in from Kansas, Missouri and the southwest generally. This is one of the first results of such a winter, and should conditions continue as up to January 20th, plant life will have many more insects to contend with next summer than if we had seasonably cold weather and a liberal quantity of snow. However, there is no use worrying, as there is yet time enough for all the cold weather we may want to kill off all the insects we want killed, and some things we do not.

It really begins to look as if we were slated for Government supervision of the seed business. Already the grass seed dealers have been brought under control to a considerable extent, and the coils are tightening all the time. If the control were just and intelligent it might be endurable, but without prejudice it can very truthfully be described as neither. To illustrate this, a prominent grass seed jobber submitted to the Department of Agriculture half of a sample of fancy red top, the other half going to his state experiment station. The two samples were identical, the lot having been placed on a paper and divided, yet the reports were radically at variance. The Washington Department found 134-100 of 1 per cent. of foreign seed and 6 per cent. of inert matter. The report then proceeds to show the number of foreign seeds to the pound on the basis of 134-100 as something over 100,000, but the number of true seeds is not given. Would it not have been fair to have done so? It would be interesting to know by what process of computation they arrived at the number of foreign seeds to the pound, or if the number given is even approximately correct. It would seem to be about up to the seedsmen, and particularly the grass seed dealer, to have a central laboratory in charge of a trained and fully equipped seed expert of such standing that his findings would be authoritative and beyond question; then when the Washington Department sends out a report like that above referred to, they can either verify or disprove it. As matters now stand, if the Department had said 1,000,000 foreign seeds, there would have been no way of disproving it excepting its inherent improbability.

Referring again to Government supervision of the seed industry, it would seem to be a perfectly logical step in view of the present trend of Government policy, and the fact that the grass seed end of it is now under such supervision; and could the right man be found for this work it might not prove an unmixed evil. Among ourselves we may as well admit that there is a great deal of faking and

humbugging of the public by seedsmen—not all by any means—but a sufficient number to discredit the entire trade. The remaining of varieties is one of the chief evils and has resulted in multiplying names to such an extent as to be a well nigh unbearable nuisance. Most seedsmen have been somewhat at fault, but the chief glory belongs to a few retailers whose names will readily occur to the reader.

The American Seed Trade Association has wrestled with this problem of multiplying names by appointing committees on nomenclature, but they have been mainly ornamental, as no practical results have ever followed. In justice to them, however, it may be said that the problem was too difficult and complex, and having no authority to enforce any conclusions they might reach, however excellent, they could do nothing. More will be said along this line in the near future.

Alaska peas are being offered at a considerable reduction in price from that ruling about January first. These offers are coming from growers and dealers. Many of these persons are like the proverbial farmer, who never will sell so long as any one wants to buy, but when the buyer loses his interest and no longer follows the farmer, the latter will promptly turn and follow him. It is certainly wonderful where all of the peas have come from this year, though the wrinkled canning sorts are still difficult to obtain, and particularly Admirals, which are not procurable at any price. Still some of these may be dug up in the near future.

Mr. and Mrs. Francis Brill of Hempstead, Long Island, celebrated their golden wedding anniversary at their home on January 1st, 1908. Owing to the failing health of Mrs. Brill the celebration was quiet and a formal reception was dispensed with. Mr. Brill's father, John Brill, was a leading horticulturist, conducting a market garden and florist business in Jersey City, and later at Newark, N. J., until the time of his death in 1870. With the advantage of these surroundings and training, Francis Brill in 1870 established a seed farm at Mattituck, L. I., where he soon made fame in cauliflower seed growing. Later the business was transferred to Hempstead. Five children are living, one of whom is the wife of Walter Bodger of John Bodger & Sons, seed growers, of Gardena, Cal. HORTICULTURE joins in the congratulations which are being extended to Mr. and Mrs. Brill from far and near, and wishes them many years yet of happiness and prosperity.

The Executive Committee of the American Seed Trade Association met at Chicago on Tuesday, January 21 and voted for Detroit, Mich., as the location for the next convention.

William Seabald will put up a \$25,000 warehouse at Curtis and Cuits avenues, Signal, Ohio, where he will deal in seeds, grain, etc.

You have a good and coming paper. It proves to me that you are hustlers.

CALIFORNIA CARNATION CO.
Loomis, Cal.

MICHELL'S

SEEDS

Are Always Reliable.

1018 MARKET ST.
PHILA.

WHOLESALE CATALOGUE FREE

GLADIOLI

I can satisfactorily supply your wants for Gladioli for forcing or outdoor planting. Mixtures, color sections or named varieties of exceptional beauty.

Write for Prices

ARTHUR COWEE

Gladiolus Specialist

Meadowvale Farm, BERLIN, N. Y.

HYACINTHS, TULIPS, NARCISSI AND OTHER BULBS ROMAN HYACINTHS and the true PAPER WHITE GRANDIFLORA

Ask for our Wholesale Trade List at Hillegom

K. VELTHUYS, Hillegom, Holland
Rep. by **FELIX BOSCH, 260 Iarndon St., Boston**

PLANT IMPORTS.

There were entered at the port of New York during the two weeks of January 7th to January 21st, inclusive, the following imports of plants, etc.:

From Rotterdam: A. T. Boddington, 33 bls. grass seed; P. Henderson & Co., 50 bgs. do.; 4 cs. bulbs; Vaughan's Seed Store, 6 pgs. seed; Weeber & Don, 86 pgs. flower seed; To Order, 48 bls. seed.

From Antwerp: H. Frank Darrow, 1 cs. bulbs; H. H. Berger & Co., 5 bbl. seed; Stump & Walter, 4 cs. bulbs.

From Germany: H. Frank Darrow, 11 pgs. seed; Wm. Elliott & Sons, 1 bbl. do.; O. G. Hempstead & Co., 6 bls. do.; Peter Henderson & Co., 2 pgs. do.; Maltus & Ware, 2 bbls. do.; 3 sacks do.; Stump & Walter, 1 bl. do.; J. M. Thornburn & Co., 2 cs. do.; Vaughan's Seed Store, 8 pgs. do.; Sundry Forwarders, 8 cs. do., 10 bls. larkspur seed.

Via Havre: H. F. Darrow, 42 pgs. plants; Amerman & Patterson, 33 pgs. seed; McHutchison & Co., 66 pgs. do.; A. H. Post & Co., 42 pgs. do.; J. M. Thornburn & Co., 155 cs. do.; To Order, 57 cs. plants, 23 cs. trees; Sundry For-

\$3000 PER ACRE IN TOMATOES

Outdoor culture. With my **Concrete or Cement Plant Protector**, Patent pending. Set plants six weeks earlier and get house prices. Will sell Town Rights and furnish mold. Send 2c stamp for circular.

J. H. HALEY, MUNITH, MICH.

warders, 600 cs. plants, etc., 31 pgs. seed.

Via Marseilles: C. C. Abel & Co., 2 cs. plants; To Order, 530 bgs. seed; Sundry Forwarders, 18 cs. plants.

Via Southampton: H. F. Darrow, 24 pgs seed, 89 cs. plants; Peter Henderson & Co., 16 bgs. seed; McHutchison & Co., 164 cs. plants; Maltus & Ware, 1 cs. seed; Sundry Forwarders, 44 cs. plants, 6 bgs. seed.

Via Liverpool: Sundry Forwarders, 2 cs. trees.

Via London: Wm. Elliott & Sons, 34 bgs. seed; Vaughan's Seed Store, 41 bgs. do; Sundry Forwarders, 45 bls. garden seed, 659 bgs. do.

From Naples: Stache, Pablo, 12 pgs. live plants; To Order, 700 bgs. seed.

"NO BETTER PAPER."

Editor of HORTICULTURE:

Dear Sir,—I have been taking HORTICULTURE about a year and am much pleased with it. It is gotten up in good style and has a very able corps of writers. There is no better paper of its kind. A. B. HATHAWAY.
New Bedford, Mass., Jan. 18, 1908.

In ordering goods please add, "I saw it in HORTICULTURE."

BEGONIAS

	Doz.	100
Single Named colors	40c	\$2.50
" Mixed "	35c	2.25
Double Named	65c	5.00
" Mixed "	50c	4.00
Gloxinias Named	50c	4.00
" Mixed "	40c	2.50

WM. ELLIOTT & SONS
201 FULTON ST., NEW YORK

WIBOLTT'S SNOWBALL CAULIFLOWER-SEED

No. 34 is the earliest of all Snowballs, the most compact, the surest header, is giving the largest and snow-whitest heads, and is the best keeper in dry-weather. Demand it through your seed-firm or direct from

R. WIBOLTT, NAKSKOV, DENMARK



Cyclamen

Superb English Strain
Second to none in size of flowers

Giant Crimson.
" Pink
" White
" White with Claret base.
" Mauve.
" Salmon Queen.
" New Fringed.

100 seeds \$1; 1000 seeds \$9.

H. E. FISKE SEED CO.
12 and 13 Faneuil Hall Square, BOSTON MASS.

CAULIFLOWER SEED
CABBAGE SEED

HJALMAR HARTMANN & CO.,
12 Stormgade,
COPENHAGEN, DENMARK.

ESTABLISHED 1802

Thorburn's Seeds

Send for our Wholesale Catalogue of Seeds for Florists and Market Gardeners, ready in a few days

	Per doz.	Per 100
GLADIOLUS PRIMULINUS	\$8.00	\$60.00
PRIMULINUS HYBRIDS	3.00	20.00

J. M. THORBURN & CO.
33 Barclay St., through to 38 Park Place
NEW YORK
Everything of the Highest Grade

"QUALITY IS REMEMBERED LONG AFTER PRICE IS FORGOTTEN."
WHAT QUALITY MEANS.

Quality means the best and finest types procurable in their respective classes. We do to specialists for our flower seeds. Our customers, the Florist the private gardener demand the highest grade. We have no cheap catalogue trade. "Quality" may mean a little higher in price. "Quality" in fact means "Quality" and we know that when you buy from us you get it;—and our customers know it too. Catalogue now in press; 40 pages. Write for one its FREE. We sell bulbs too.

ARTHUR T BODDINGTON
SEEDSMEN
342 West 14th St., NEW YORK.

	Pkt.	Oz.
Agrotatum Blue Perfection	\$0.15	\$0.50
Alyssum Little Gem	.10	.35
Ca dy Tuft Empress	.10	.20
Bellis Snowball	.25	
" Longfellow	.25	
Salvia Splendens	.25	1.35
" Bonfire	.25	2.50
Verbena Mammoth Mixed	.25	1.50

BRIDGEMAN'S SEED WAREHOUSE
RICKARDS BROS., Props.
37 East 19th St., NEW YORK CITY

BRASLAN SEED GROWERS CO.
GROWERS FOR THE
WHOLESALE TRADE ONLY
SAN JOSE, - - CALIFORNIA
Burpee's Seeds
PHILADELPHIA

Blue List of Wholesale Prices mailed only to those who plant for profit

BAMBOO CANES **TOUGH AND STRONG**

6 ft. long — \$1 per 100; \$6 per 1000; \$11 per 2000

They cost about 10 per cent. more than other kinds, and they are 10 times better.

STUMPP & WALTER CO., - 50 Barclay St., New York

RELIABLE SEEDS — NOW NOW

	Tr.	6 Tr.
Alyssum Carpet Queen real dwarf for pots only, no equal....	\$0.25	\$1.25
Begonia Gracilis Luminosa, oew	0.50	2.50
Erfordia, beautiful.....	0.50	2.50
Lobelia, new Trading Hamburga	0.30	1.50
Petunia, Double Fringed Giants...	1.00	5.00
Single Fringed Giants...	0.75	4.00
Phlox, best for pots, Fireball, Roseball, Snowball, each color.....	0.25	1.25
Salvia Fireball, new, a fine potter	0.50	2.50
Stocks, German 10 weeks: Blood-red, Lavender, Pink, Purple, White, each color.....	0.50	2.50
Verbena Mammoth: Pink, Purple, Scarlet, Striped, White, each	0.25	1.25

My New Price List Ready for the Asking
O. V. ZANCEN
Seedsman, HOBOKEN, N. J.

Best Quality Fall Bulbs

It is to your advantage to place your order early. Send us a list of your wants and we will quote you rock-bottom prices. Copy of our Florists' Bulb Catalogue will be sent upon request. Catalogues now ready.

VICK'S SUPERB PANSY SEED
All the best varieties in separate colors
VICK'S SUPERB MIXTURE

the best strain from all the leading named sorts
1-8 oz. 75c. 1-4 oz. \$1.50 Ounce \$5.00

JAMES VICK'S SONS, Rochester, N. Y.

CYCLAMEN
Farquhar's Giant Strain

Unsurpassed for size of flowers.

Giant Crimson Giant Pink
Giant White Finest Mixed
Giant Excelsior, White with Claret Base

100 seeds, \$1.25; 1000 seeds, \$10.00.

R. & J. FARQUHAR & CO.
6 & 7 So. Market St., Boston, Mass.

BRECK'S SEEDS
For Farmer, Market Gardener and Florist
New Crop High Grade
Catalogues mailed free on application

Joseph Breck & Sons Corp.
47-54 NO. MARKET ST., BOSTON, MASS.

JUST ARRIVED
LARGE SHIPMENT OF
High-Grade SCOTCH SOOT.

We have the stout Double Nozzle
THOMAS J. GREY CO.
32 & 33 So. Market St., BOSTON

C. C. MORSE & CO.

Address all communications to our permanent address
48 to 56 Jackson St., San Francisco, Cal.

The Largest Seed Growers in the United States

PHILADELPHIA NOTES.

Begonia Duke of Marlboro is considered by Charles H. Campbell to be a grand Christmas plant. Its grey-white trusses are massive, freely produced and borne well above the foliage. He has found it a good seller the past three seasons.

George Anderson thinks that the ruling averages on cut roses this season will have some effect on the automobile industry, and that there will be a few good second-hand machines for sale among the flower growers next June. At this writing we have been unable to get a price on Mr. Anderson's own "devil-wagon."

Christian Eisele has purchased the dwelling and large rear lot on the north of his present property at 11th and Roy Sts. The Westmoreland St. extension is expected to go through this season and will take away his old dwelling and part of his greenhouses, for which he has been awarded \$7,000 by the city. Hitchings & Co. have the contract to rebuild three houses 60 x 15 feet. Mrs. Claus, a neighboring florist, has been awarded \$5,300 for the damages to her greenhouses, etc., for the same street extension, but we understand she does not intend to rebuild.

Godfrey Aschman believes the great secret of his success in Easter lily culture lies in having the bulbs well ripened before potting them, and then keeping them growing slowly at first, but without the slightest check. If careful attention be given to these two points, little will be heard in the land as to bad bulbs.

Edward Reid left on the 20th inst. on a brief gunning trip to North Carolina. A trip like this is a good antidote for the rather backward trade conditions this year. It is also fine when the season happens to be unusually prosperous. In fact, it resembles the Duke of York's special brew—"warm in winter, cool in summer, good all the year."

A large audience assembled in Horticultural Hall on the 21st inst. to listen to J. Otto Thilow's lecture on the Yellowstone Park. The lecture was splendidly illustrated with stereopticon views.

W. K. Harris, while able to be around after his severe illness of last fall, is still far from his normal self. He and Commodore Westcott are contemplating a trip to the Bermudas for a few weeks' rest, recuperation and change of air.

Spring show of Pennsylvania Horticultural Society will open March 31.

DAYTON NEWS.

In a very cordial letter, Mr. H. H. Ritter writes us that business in Dayton has been generally satisfactory this season, the flower trade being fairly busy. The plant trade is not as good as it might be, as elsewhere the weather has been unseasonably spring like. Mr. Ritter says: "One day last week I picked about a dozen dandelion blooms in my yard; but now we are having cold weather with the sun nice and bright, which brings us good stock." Among recent visitors were Fred Beerhorst, Holland, and W. C. Johnson, Cambridge, Ohio.

You will find something worth reading on every page of HORTICULTURE.

EXTRA FINE BOXWOOD \$17.50 per CWT.

FANCY FERNS, A No. 1 Quality, \$1.50 per 1000
GREEN CALAX \$1 per 1000, \$7.50 per 10,000
BRILLIANT BRONZ \$1 per 1000, \$8.50 per 10,000

Headquarters for HARDY FERNS, MOSS, LAUREL,
PRINCESS PINE, FESTOONING, Etc. See Our Cut Flower Ad.
HENRY M. ROBINSON & CO., FLORISTS' SUPPLIES 15 Province St., and 9 Chapman Pl., BOSTON



GALAX LEAVES.

GALAX, SPRAYS and FERNS

All fresh and fine. Handled by experienced hands

GALAX, green or bronze, 45c per 1000
FERNS, fancy or dagger, 75c "
LEUCOTHOE SPRAYS, green or bronze. \$2.50 "



DAGGER FERNS.

TERMS: Cash with first order. Discount on lots of 50,000 and up. Send us your orders and get just what you want, and get it QUICK.

T. J. RAY & CO., - - - Elk Park, N. C.

NEWS NOTES.

A. E. Jennings, florist, of Toronto, Can., has made an assignment.

W. C. Hawkins has started in the florist business in Palestine, Texas.

A dividend of 20 per cent. has been declared to the creditors of A. J. Feltonris, New York.

W. J. Kingsbury, of West Derry, N. H., has purchased the Smith greenhouses and will continue the business.

E. F. Hauser has purchased the Prospect avenue greenhouses at Rutledge, Pa., and will make changes and improvements.

The Meuret greenhouses at Park Ridge, Chicago, have been leased by L. C. Schelt. Mr. Meuret will locate near by and put up new houses.

Charles De Clerc will open an office in the Hoffman Building, Green Bay, Wis., about February 1, where orders may be taken for the stock to be grown in his new houses near the Fort Howard cemetery.

Leonard Barron, managing editor of the Garden Magazine, gave a lecture in the Free Lecture Course of the American Institute at the Berkeley Lyceum, New York City, on Wednesday, January 22, on "Everybody's Flower Garden," with suggestions on plans of arrangement for harmonious color effect. The lecture was illustrated with stereopticon slides of great interest and was enjoyed by a large and appreciative audience.

FIRE RECORD.

A fire that started in the boiler room injured the greenhouses of W. L. Porter, of Ogden, Utah, to the amount of \$3000. No insurance.

A greenhouse belonging to Dr. D. J. Nagel, of New York, at his summer residence on Game Cock Island, was destroyed on January 8. Loss about \$800.

E. A. BEAVEN
Southern Wild Smilax,
Log Mosses,
Natural and Perpetuated — at Wholesale,
EVERGREEN, ALABAMA.

BOSTON FLORIST LETTER CO.
Manufacturers of FLORISTS' LETTERS

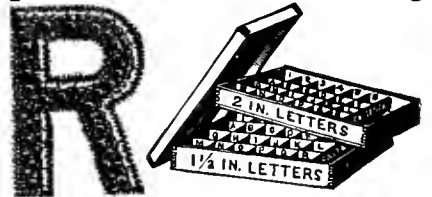

This wooden box nicely stained and varnished, 18x30x12, made in two sections, one for each size letter, given away with first order of 500 letters
Block Letters, 1 1/2 or 2 inch size per 100, \$2.
Script Letters, 3. Fastener with each letter or word. Used by leading florists everywhere and for sale by all wholesale florists and supply dealers
N. F. MCCARTHY, Manager
66 Pearl Street, BOSTON, MASS.

BOXES BOXES BOXES
LIGHT WOOD CUT FLOWER BOXES

Sizes in Stock	per 100
3 x 4 x 20	\$4.00
3 x 5 x 24	4.50
3 x 7 x 21	4.50
6 x 6 x 24	6.80
4 x 12 x 24	9.00
6 x 12 x 24	10.50
6 x 12 x 30	12.50
5 x 12 x 36	14.00
6 x 12 x 36	15.00
6 x 15 x 42	20.00
6 x 15 x 48	23.00

Write for samples and prices in car load lots.
GETMORE BOX FACTORY, Incorporated,
BELLEVILLE, ALA.

The "Japana" Cut Flower Holder

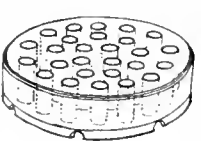

A handy article for florists. Sells to the trade on sight. Made of glass in three sizes. The "Anglais" Table Decoration, something entirely new, long needed. The florist and housewife will appreciate this article, as it simplifies the art of table decorating.

Ask for catalog.
M. V. CARNSEY, Dept. J,
130 Waiola Ave., La Grange, Ill.

KORAL SCRIPT LETTERS AND EMBLEMS
ONCE USED ALWAYS USED
For sale by all first class supply houses. Made by
KORAL MFG. CO.
26 Hawley St., Boston

BUSINESS CHANGES.

Schmidt & Gorkel, Fort Thomas, Ky., have succeeded E. H. Fries.

E. G. Gillett, Cincinnati, has moved from 113 to 114 East Third street.

Frank Manker has purchased the greenhouse of J. Hogan, Gravesend, N. Y.

C. Vasatka and L. K. Grisback have leased the greenhouses of R. Wessling, Minneapolis, Minn.

Schloss Bros., New York, dealers in ribbons, will begin business on February 1 in their new quarters, 542 Broadway.

O. H. Diffendarfer has disposed of his interest in the Wagoner Floral Co., Ft. Wayne, Ind., to his partner, A. J. Waggoner.

Miss Fannie Lee has closed her greenhouse at Marshall, Mich., and is now in charge of a branch store for H. A. Fisher & Co., at Battle Creek.

NEW RETAIL STORES.

C. Weiss, 1 East 41st St., New York City.

Peter Ness, 1324 N. Western avenue, Chicago.

Franken Bros., Central avenue, Cincinnati, O.

Geo. C. Hartung, 11816 Michigan avenue, Kensington, Chicago.

Mr. Maurice Wolff has again started a stand on Woodward avenue, Detroit. Some years ago he did a good deal to abate carnation and aster gluts, but this year the supply is none too heavy.

INCORPORATED.

American Nursery Co., New York, by F. W. Kelsey, Theo. Foulk, Wm. Flemer; capital, \$100,000.

Mackintosh, florist, New York, by Elizabeth Mackintosh, Jas. Malone, C. A. Flynn; capital, \$2,500.

LEADING RETAIL FLORISTS—
Index by Towns will be found in Buyers' Directory.



Send flower orders for delivery in **BOSTON**

and all **NEW ENGLAND POINTS**
THOS. F. CALVIN
124 Tremont St., Boston

TRANSFER

Your orders for flower or plant delivery in Eastern New England to

JULIUS A. ZINN,
2 Beacon St., Boston.
Fine Design Work a Specialty.

ATLANTA FLORAL CO.
41 Peachtree Street, ATLANTA GEORGIA.

Florists Out of Town

Taking orders for delivery in **New York or Vicinity** can have them filled in best manner and specially delivered by

Thomas Young, Jr.

41 W. 28th St., New York City

ALEX. McCONNELL

571 FIFTH AVENUE
NEW YORK CITY

Telegraphic orders forwarded to any part of the United States, Canada, and all principal cities of Europe. Orders transferred or intrusted by the trade to our selection for delivery on steamships or elsewhere receive special attention.

Telephone Calls, 487 and 488 38th St.
Cable Address, ALEXCONNELL

WILLIAM H. DONOHUE

FLORAL DECORATOR

17 East 28th St., New York

Special Attention to Theatre and Steamer Orders, and reliable deliveries guaranteed.

DAVID CLARKE'S SONS

Deliver orders from any part of the country to **New York City**

Or **OUT-GOING STEAMERS**

Write or telegraph

2139-2141 Broadway, New York

Telephone 1552-1553 Columbus

PROMPT DELIVERY IN BOSTON

AND ALL NEW ENGLAND POINTS

HOUGHTON & CLARK

396 Boylston St., Boston, Mass.

Flower Deliveries

In Brooklyn and other Long Island Points New York City, New Jersey etc. At Theatres, Hotels, Steamers or Residence: s.

WILSON

Fulton St. and Greene Ave., Brooklyn, N.Y.

YOUNG & NUGENT

42 West 28 St., NEW YORK

"FLOWERS BY TELEGRAPH"

William J. Smyth
FLORIST

Cor. Michigan Ave. and 31st St., CHICAGO

We ship to all points in Illinois and Iowa.

Phones: Douglas 744, Douglas 523, Douglas 740

JACOB SCHULZ, 644 Fourth Ave., LOUISVILLE, KY.
Cut Flowers of BEST QUALITY in season delivered promptly to any address.

Write, Telegraph or Telephone.
Cumberland and Home Phones 223 and 984

JOHN BREITMEYER'S SONS

Cor. Miami and Gratiot Aves.
DETROIT, MICH.

Artistic Designs . . .
High Grade Cut Blooms

We cover all Michigan points and good sections of Ohio, Indiana and Canada

P. J. HAUSWIRTH

232 Michigan Ave.
CHICAGO

AUDITORIUM ANNEX Tel. Harrison 585

SAMUEL MURRAY Florist

Coates House Conservatory
1017 BROADWAY, KANSAS CITY, MO
Both 'Phones 2670 Main

FRED C. WEBER FLORIST

4326-28 OLIVE STREET ST. LOUIS, MO.
Established 1873
Long Distance Phone Bell Lindell 676



WASHINGTON, D. C.

GUDE'S

Geo. H. Cooke FLORIST

Connecticut Avenue and L Street
WASHINGTON, D. C.

The Park Floral Co.

J. A. VALENTINE
Pres.

DENVER, COLORADO

WILLIAM L. ROCK FLOWER CO.

KANSAS CITY, MO.

will carefully execute orders for Kansas City and any town in Missouri or Kansas.

ALBANY, N. Y.

EYRES

Flowers or Design Work

DELIVERED IN ALBANY AND VICINITY ON TELEGRAPHIC ORDER.

11 NORTH PEARL ST., ALBANY, N.Y.

CARNATIONS — Rooted Cuttings

Healthy, well-rooted stock the product of the most reliable growers of this locality

	Per 100	Per 1000		Per 100	Per 1000		Per 100	Per 1000
White Enchantress,	\$6.00	\$50.00	Enchantress,	\$2.50	\$20.00	Harlowarden,	\$2.00	\$18.00
White Perfection,	3.00	25.00	Helen Goddard,	2.50	20.00	Matton,	2.50	20.00
White Lawson,	2.00	18.00	Lawson,	2.00	18.00	Fenn,	2.00	18.00
Queen Louise,	2.00	18.00	Peacon,	6.00	50.00	Red Sport,	2.00	18.00
Winsor,	6.00	50.00	Victory,	3.00	25.00	Boston Market,	2.00	18.00
Aristocrat,	6.00	50.00	Craig,	3.00	25.00	Joost,	2.00	18.00
Rose Pk. Enchantress,	3.50	30.00						

NEW CROP SEEDS
ASPARAGUS PLUMOSUS NANUS \$4.50 per 1000.
 Special prices on large quantities. Greenhouse Crown, Hard Selected

MRS. JARDINE: the sensational new pink rose: 2½ inch pots: \$30.00 per 100, \$250.00 per 1000
 Orders Booked Now

S. S. PENNOCK-MEEHAN COMPANY, "THE" Wholesale Florists of
 1608-1620 Ludlow Street, PHILADELPHIA

EVERYTHING SEASONABLE IN
CUT FLOWERS
EDWARD REID, Wholesale Florist
 1526 RANSTEAD ST., PHILADELPHIA
 STORE CLOSES 8 P. M.

CHAS. W. McKELLAR
 51 WABASH AVE., CHICAGO
 Western Headquarters for Choice Orchids
 Valley, Roses and all Cut Flowers

PETER REINBERG
 WHOLESALE
CUT FLOWERS
 51 Wabash Av., Chicago, Ill.
 In writing advertisers mention Horticulture

CUT FLOWER BOXES
EDWARDS FOLDING BOX CO
 MANUFACTURERS
 PHILADELPHIA, PA.

AMERICAN BEAUTY and all other
ROSES
LILY OF THE VALLEY, CARNATIONS
WELCH BROS., 226 Devonshire St., Boston, Mass.

TRUMPET MAJORS
 Extra Quality Any Quantity
W. E. McKISSICK WHOLESALE FLORIST
 PHILADELPHIA
 1619-1621 RANSTEAD ST.
DAILY CONSIGNMENTS
 From 40 to 60 Growers
 We can care for your cutflower wants to advantage.
E. F. WINTERSON CO.
 45-47-49 WABASH AVE., CHICAGO

ROBERT J. DYSART,
Public Accountant and Auditor
 Simple methods of correct accounting especially adapted for florists' use.
Books Balanced and Adjusted
 Merchants Bank Building
28 STATE ST., BOSTON
 Telephone, Main 38

WHOLESALE FLOWER MARKETS
 TRADE PRICES — Per 100 — TO DEALERS ONLY

	CHICAGO Jan. 20		TWIN CITIES Jan. 20		PHILA. Jan. 21		BOSTON Jan. 23	
ROSES								
Am Beauty, Fancy and Special...	35.00	to 40.00	50.00	to 60.00	50.00	to 60.00	40.00	to 50.00
" " Ex 12	25.00	to 30.00	40.00	to 50.00	35.00	to 50.00	20.00	to 30.00
" " No. 1	15.00	to 20.00	20.00	to 30.00	20.00	to 30.00	16.00	to 15.00
" " Lower grades	6.00	to 10.00	12.00	to 18.00	6.00	to 20.00	6.00	to 8.00
Bride, 'Maid, Fantasy & Special	8.00	to 10.00	10.00	to 12.00	12.00	to 14.00	11.00	to 12.00
" " Extra	5.00	to 6.00	8.00	to 10.00	14.00	to 12.00	6.00	to 8.00
" " Lower grades	3.00	to 4.00	6.00	to	4.00	to 10.00	2.00	to 4.00
Killarney, Richmond, Fan & Sp.	8.00	to 12.00	10.00	to 12.00	12.00	to 20.00	12.00	to 25.00
" " Lower grades	4.00	to 6.00	4.00	to 8.00	6.00	to 12.00	4.00	to 6.00
Chat-nay, Wellesley, Fan & Sp.	8.00	to 12.00	10.00	to 12.00	12.00	to 15.00	12.00	to 15.00
" " Lower grades	4.00	to 6.00	4.00	to 8.00	4.00	to 12.00	6.00	to 8.00
Golden Gate Ivory	4.00	to 10.00	10.00	to 12.00	4.00	to 10.00	6.00	to 8.00
CARNATIONS								
Fancy and Novelties	4.00	to 5.00	4.00	to 5.00	4.00	to 6.00	3.00	to 4.00
Ordinary	2.00	to 3.00	3.00	to 4.00	1.50	to 3.00	2.00	to 3.00
MISCELLANEOUS								
Violets	.75	to 1.00	1.00	to 1.50	.25	to 1.00	.50	to .75
Cattleyas	50.00	to 60.00	50.00	to 60.00	50.00	to 60.00	40.00	to 50.00
Cypripediums	to 15.00	15.00	to 18.00	12.50	to 15.00	to 12.00
Lilies	15.00	to 18.00	15.00	to 18.00	12.50	to 18.00	12.00	to 16.00
Lily of the Valley	3.00	to 4.00	4.00	to 5.00	12.00	to 5.00	2.00	to 4.00
Roman Hy., Paper White Nar.	3.00	to 4.00	3.00	to 4.00	2.00	to 3.00	1.00	to 2.00
Stevia	1.00	to 2.00	to	1.00	to 1.50	1.00	to 1.50
Mignonette	3.00	to 8.00	3.00	to 4.00	2.00	to 6.00	3.00	to 6.00
Aspidistra	.75	to 1.00	1.00	to 1.50	1.00	to 1.50	1.00	to 1.50
Whitmanii Fronds	to	4.00	to 5.00	to	1.00	to 2.00
Smilax	12.00	to 15.00	14.00	to 18.00	12.50	to 20.00	12.00	to 16.00
Asparagus Plumosus, strings	35.00	to 50.00	45.00	to 60.00	50.00	to 75.00	to 50.00
" " & Sprea. (100 bchs.)	35.00	to 50.00	40.00	to 60.00	35.00	to 50.00	to 50.00

THE FLORISTS' SUPPLY HOUSE OF AMERICA

Without a rival in knowledge of the requirements of the trade and the ability to supply them. Our New Illustrated Catalogue, recognized as a work of art unprecedented in its line for variety, novelty and completeness, tells the story fully, and if you have not yet sent for it, do so now.

IT'S FREE TO EVERYBODY IN THE TRADE

H. BAYERSDORFER & CO., 1129 Arch St., Philadelphia, Pa.

PHILADELPHIA PLANT EXCHANGE

We aim to give our patrons the best values every week. Write us for anything you are in the market for. We handle your surplus stock also, our only charge being 10 per cent on sales.

THIS WEEK'S BARGAIN OFFERS:

MADE UP PLANTS			
300 KENTIA FORSTERIANA, 6 inch,	\$1.50 each	500 PLUMOSA, 3 inch,	\$5.00 per 100
200 " " 7 inch,	2.00 "	1000 MIXED FERNS, 3 inch,	7.00 "
These are made up plants, clean and well furnished. A decided bargain at the price.		500 RUBBERS, 4 inch,	25.00 "
4000 BOSTON MARKET CUTTINGS,	\$18.00 per 1000	400 WHITMANI, 4 inch,	25.00 "
3000 ENCHANTRESS " "	20.00 "	500 FIGUS CUTTINGS, well rooted,	15.00 "
		3000 JOOST CUTTINGS,	17.00 per 1000
		3000 MAKION " "	17.00 "
		TODEAOIDES FERNS, 2 1/2 inch,	20.00 per 100

ADDRESS ALL ORDERS TO

PHILADELPHIA PLANT EXCHANGE, 839 Market Street, PHILADELPHIA, PA.

Don't grow crops there is no demand for. Write us first. We cannot handle anything unless it is first class in every way.

To Cut Flower Growers and Retail Florists

IF YOU

want to find a market for your product
want a regular or special supply of the product of the best growers

Consult the Advertisements on these Wholesale Flower Pages

The Advertisers Represented Here are the Leading Concerns in the Wholesale Flower Trade

A Fine Assortment of ==AZALEAS==

Extra fine lot of FIREFLY in bloom from
NOW UNTIL EASTER

WRITE FOR PRICES

MAJOR BONNAFFON

The best all 'round Yellow Chrysanthemum. Strong stools,
\$5.00 per 100

W. W. EDGAR CO., Waverley, Mass.

FLOWER MARKET REPORTS

BOSTON Business in general has flattened out a little this week. On the whole it may be called dull. Roses are not suffering to any extent. Hitherto they have been rather on the short side. The present weakness in demand only makes them a little easier to obtain and has not affected market prices. With carnations the situation is different. There is a decided slump and the market is badly overstocked. Dark pink of the Lawson type is the most affected. Whites and Enchantress have held their own nicely. All stock is much more plentiful than at a corresponding date last year.

BUFFALO The first part of last week was rather dull but toward the end business brightened up considerable. Stock on all lines has been in fairly good supply, violets, peas, carnations, and bulbous stock. Yellow flowers were in demand, and tulips and daffodils filled the bill. Roses were a trifle scarce, especially select Bridesmaid, Killarney and Richmond. Beauties were in good supply and at fine quality; demand a little weak but many were used to good advantage at a hotel opening on Saturday, which helped to clean up. All other flowers were had in quantity.

DETROIT Business is moving along slowly with good healthy prices, wholesale and retail. Every now and then we experience a little rush, but we could all stand more. Collections are reported satisfactory.

INDIANAPOLIS Quiet conditions prevail at the present time with the majority of florists. While in certain stock scarcities exist, the market is in exceptional condition for this time of year, due to the phenomenal weather conditions. Good roses of all kinds and carnations are plentiful, with a marked decrease in prices. Violets, lily of the valley, orchids and lilacs are coming in regularly, but are not realizing nearly what they did in former years. Bulbous stock is plentiful but moves slowly. Paper Whites and Roman hyacinths being a drug on the market. Quite a variety of good flowering plants are seen but move slowly. The market is well stocked on green goods, with a moderate sale. Growers of palms and ferns are complaining at dull trade.

NEW YORK The rose market shows some improvement. Conditions generally are fully as good as last week and in some respects better. The receipts of carnations in the wholesale markets are on the increase. Violets are also in heavy supply and demand is light. Daffodils and tulips are coming in very freely. Lily of the valley is doing somewhat better. Sweet peas of fine grade are in evidence and sell satisfactorily. While values are lower generally than one year ago it is pleasant to know that the cost of production is also lower and that the coal bins are holding out unusually well.

Many things are **PHILADELPHIA** off crop and shipments are perceptibly less than last week. While there is a little more life to the market, and things clean up better, there is no increase in prices. Violets are more of a drug than anything else, both single and double coming in far too freely. The good weather has given the street men a chance to move many of them but there are daily mountains of them still remaining. If the demand were better Beauty roses would be a very scarce article. The Richmond market is in good shape. Killarney is ahead of Bridesmaid as to quality and demand in the pink class. There are many who think that Bridesmaid has already taken second place as a pink rose, and there is no telling what Jardine will do by and by. She certainly looks formidable. Now for a good new white. Montgomery white sport from Killarney will be worth the watching.

The unseasonably **WASHINGTON** warm, bright weather has been a godsend to the coal piles, and has materially increased the bloom. Home grown flowers are much more plentiful, but the prices have not declined appreciably. There is an overabundance of violets, and they are not of a particularly good quality, but carnations are improving.

The KERVAN CO. 113 W. 28th St. New York

WHOLESALE DEALERS
Fresh cut Palmetto & Cycas Palm Leaves, Galax, Leucodermis, Ferns and Mosses. All Decorating Evergreen.

JOHN YOUNG
WHOLESALE FLORIST
 Finest American Beauties and
 Carnations
 51 West 28 St. - NEW YORK

FORD BROTHERS
 48 West 28th Street, NEW YORK
FINE ROSES FANCY CARNATIONS
 A Full Line of All CUT FLOWERS
 Telephone, 3570 or 3871 Madison Square

H. E. FROMENT,
 Wholesale Commission Florist,
 Choice Cut Flowers,
 57 West 28th St., :: NEW YORK.
 Telephones: 2200, 2201, Madison Square.

The Reliable Commission House
 Richmond Roses and Rich Flowers
 of all varieties
JOS. S. FENRICH
 110 W. 28th Street, New York
 Tel. 324-325 Madison Square

Established 1891 BUY FROM SHIP TO TRY **ME**
ALFRED H. LANGJAHR
 All Choice Cut Flowers in Season
 55 West 28th St., New York
 Telephone 3924 Madison Square.

JOHN I. RAYNOR
Wholesale Commission Florist SELLING AGENT FOR LARGEST GROWERS
 A full line of Choice Cut Flower stock for all purposes. Comprises every variety
 grown for New York market, at current prices
 TEL. 1998 MADISON SQUARE 49 W. 28 St., New York City

Walter F. Sheridan
 Wholesale Commission Dealer in
CHOICE CUT FLOWERS
 39 West 28th Street, New York
 Telephone: 3532-3533 Madison Square

HEADQUARTERS FOR NOVELTIES
ORCHIDS A SPECIALTY
 THE HIGHEST GRADE OF **VALLEY** ALWAYS ON HAND
GARDENIAS, DAISIES, ROSES AND CARNATIONS
 Telephone
JAMES McMANUS, 789 Mad. Sq. 42 W. 28th St., New York

PHILIP F. KESSLER 55 & 57 W. 26th St., New York City
 Commission Dealer, Wholesale Buyer and Seller of
CUT FLOWERS
 Open from 5 a. m. to 6 p. m. Sunday till 10 a. m.
 Tel., 5243 and 2921 Madison Sq. Res., 345 J., Newtown.
Finest Lilies in the Market Every Day in the Year.

WHOLESALE COMMISSION FLORIST **J. K. ALLEN** 106 W. 28 ST. NEW YORK
 Telephone 167 Madison Sq.
 OPEN 6 A. M. DAILY
 We have a good regular outlet for seasonable flowers

NEW YORK QUOTATIONS PER 100—TO DEALERS ONLY

	Last Half of Week ending Jan. 18 1908		First Half of Week beginning Jan. 20 1908		Last Half of Week ending Jan. 18 1908		First Half of Week beginning Jan. 20 1908	
Roses								
Am. Beauty, Jan and sp.	20.00	to 50.00	30.00	to 60.00				
" extra	15.00	to 20.00	15.00	to 25.00				
" No. 1	10.00	to 15.00	12.00	to 15.00				
" Lower grades	1.00	to 5.00	1.00	to 2.00				
Bride, 'Maid, Jan and sp.	10.00	to 12.00	8.00	to 12.00				
" extra	7.00	to 8.00	5.00	to 6.00				
" lwr. grs.	1.00	to 3.00	1.00	to 3.00				
Kill-rney, Richmond, Nancy & spec	10.00	to 15.00	10.00	to 15.00				
" lower grades	2.00	to 6.00	2.00	to 4.00				
Chatenay, Wellesley, Jan. and spec.	6.00	to 8.00	5.00	to 10.00				
" lower grades	2.00	to 4.00	1.00	to 3.00				
Golden Gate, Ivory	2.00	to 3.00	1.00	to 4.00				
Carnations, Fancy and Novelties	3.00	to 5.00	2.00	to 6.00				
" Ordinary	1.00	to 2.00	1.00	to 2.00				
Violets	.30	to .60	.40	to .60				
Cattlevas 25.00 to 60.00 25.00 to 57.00								
Cypripediums 6.70 to 10.00 6.00 to 8.00								
Lilies 6.00 to 12.00 8.00 to 10.00								
Lily of the Valley 1.00 to 3.00 1.00 to 4.00								
Gardenias 13.00 to 25.00 10.00 to 25.00								
Roman Hy., Paper White Nar. ... 1.00 to 3.00 1.00 to 2.00								
Stevia 1.00 to 1.00 to 1.00								
Pignonette 3.00 to 6.00 2.00 to 5.00								
Adiantum 1.00 to 1.50 1.00 to 1.50								
Smilax 8.00 to 12.00 8.00 to 10.00								
Asparagus Plumosus, striggs ... 25.00 to 50.00 25.00 to 40.00								
" " & Sprea. (too bchs.) 10.00 to 15.00 10.00 to 15.00								

B. S. SLINN, Jr.
 —WHOLESALE FLORIST—
 55 & 57 W. 26th St., New York City
 Tel., 3864 Madison Sq. Shipping Orders Solicited.
VIOLETS **Roses and Carnations**

Edward C. Horan
Wholesale Florist
 55 WEST 28th ST.
 Tel. 1462 Madison Square New York

TRAENDLY & SCHENCK
WHOLESALE FLORISTS
 Furnish best stock at fair prices all the year round Send for quotations on fall orders
 Tel. 798.799 Madison Sq. 44 West 28th Street, New York City

Alexander J. Guttman
THE WHOLESALE FLORIST OF NEW YORK
 43 WEST 28th STREET
 PHONES. 1664--1665 MADISON SQUARE.
ENOUGH SAID



HARDY CUT FERNS

Sphagnum Moss, Extra Large Bales, per bale, \$1.25. Fancy and Dagger Ferns our specialty. A trial order will convince you that we ship only first-class stock. Headquarters for Florists' supplies and wire work. All cut flowers in season. **BOXWOOD**, per bunch 35c, 50 lbs. \$7.50.

MICHIGAN CUT FLOWER EXCHANGE, INC.,

All 'phone connections

38-40 Broadway, Detroit, Mich.

WHOLESALE FLORISTS
54 West 28th St.
NEW YORK
Telephone 3559 Madison Sq.

A. L. YOUNG & CO.

RECEIVERS & SHIPPERS OF CUT FLOWERS.
CONSIGNMENTS SOLICITED.

Headquarters in Western New York
FOR
ROSES, CARNATIONS
And all kinds of Seasonable Flowers
Wm. F. Kasting Co.
Wholesale Commission Florist, also Dealer in
Florists' Supplies and Wire Designs.
383-87 ELLICOTT ST.
BUFFALO, N. Y.
Give us a trial. We can please you.

FRANK S. HICKS & CO.
Wholesale Florists.
Open Now for Consignments of Cut Flowers.
52 West 28th Street, - New York City
Tel. 2920 Mad. Sq.

FRANK MILLANG
Wholesale Florist
Telegraphic Orders Filled and Delivered.
55-57 West 26th St., New York City.

Charles Millang
50 West 29th St., New York City
Cut Flowers on Commission
A Reliable Place to Consign to or order from
Telephone: 3860-3871 Madison Square

A. MOLTZ
Will purchase flowers on order in
N. Y. market and ship carefully at
prevailing wholesale prices. Address
55-57 West 26th Street, New York City

Best Flowers
IN THE
BOSTON MARKET
N. F. McCarthy & Co.
84 Hawley St., BOSTON, MASS.
Send for Prices

HENRY M. ROBINSON & CO.
WHOLESALE COMMISSION FLORISTS
Finest Grades of Roses, Carnations, Chrysanthemums, Lily of the Valley, Violets, etc.
15 Province St. & 9 Chapman Pl., Boston, Mass.
See our Fern ad.

SAMUEL A. WOODROW
WHOLESALE PLANTSMAN
Palms, Large and Small Ferns, etc.
53 West 30th Street, NEW YORK
Telephone 2083 Madison

WILLIAM H. KUEBLER
Brooklyn's Foremost and Best
WHOLESALE COMMISSION HOUSE
A First Class Market for all CUT FLOWERS
28 Willoughby St., Brooklyn, N. Y.
Tel. 4591 Maio

CLEARY'S HORTICULTURAL CO.
Management AMBROSE T. CLEARY
Wholesale Contracting, Jobbing, Auction
HORTICULTURAL PRODUCTS
of every description.
Consignments Received. Surplus Stock Converted.
62 Vesey St., NEW YORK

Moore, Hentz & Nash,
Wholesale Commission Florists,
55 and 57 West 26th Street,
Telephone No. 756
Madison Square. **New York.**

WHOLESALE FLOWER MARKETS. — PER 100. TO DEALERS ONLY.

	CINCINNATI Jan. 21	DETROIT Jan. 19	BUFFALO Jan. 20	PITTSBURG Jan. 20
ROSES				
Am. Beauty, Fan. and Sp.	30.00 to 40.00	50.00 to 65.00	40.00 to 50.00	30.00 to 40.00
" Extra	20.00 to 25.00	25.00 to 30.00	20.00 to 30.00	20.00 to 25.00
" No. 1	10.00 to 15.00	20.00 to 25.00	10.00 to 15.00	10.00 to 15.00
" Lower grades	4.00 to 5.00	6.00 to 10.00	5.00 to 10.00	4.00 to 5.00
Bride, 'Maid, F. & S.	10.00 to 1.00	10.00 to 12.00	10.00 to 15.00	10.00 to 12.00
" Extra	6.00 to 8.00	8.00 to 10.00	8.00 to 10.00	8.00 to 10.00
" Low gr.	4.00 to 6.00	6.00 to 8.00	4.00 to 6.00	4.00 to 6.00
Killarney, Richmond, Fan. & Sp.	12.00 to 15.00	8.00 to 10.00	10.00 to 15.00	12.00 to 15.00
" Lower grades	8.00 to 10.00	6.00 to 8.00	6.00 to 10.00	8.00 to 10.00
Chatenay, Wellesley, Fan & Sp.	10.00 to 12.00	8.00 to 10.00	12.00 to 15.00	10.00 to 12.00
" Lower grades	6.00 to 8.00	6.00 to 8.00	6.00 to 10.00	6.00 to 8.00
Golden Gate, Ivory	6.00 to 8.00	8.00 to 10.00	4.00 to 10.00	6.00 to 8.00
CARNATIONS				
Fancy and Novelties	3.00 to 4.00 to 4.00	4.00 to 5.00	3.00 to 4.00
Ordinary to 2.00	2.00 to 4.00	2.00 to 3.00 to 1.00
MISCELLANEOUS				
Violets	50 to 1.00	1.00 to 1.50	1.00 to 1.25	1.50 to 1.00
Cattleyas	30.00 to 10.00	31.00 to 50.00 to 30.00	30.00 to 60.00
Cypripediums	12.00 to 15.00	8.00 to 10.00	10.00 to 15.00 to 15.00
Lilies	12.00 to 15.00	20.00 to 25.00	5.00 to 15.00 to 15.00
Lily of the Valley	3.00 to 4.00	3.00 to 4.50	3.00 to 4.00	3.00 to 4.00
Roman Hy., Paper White Nar.	1.00 to 3.00	3.00 to 4.00	2.00 to 3.00	1.00 to 3.00
Stevia to 1.00	2.00 to 3.00	1.00 to 1.25 to 1.00
Mignonette	2.00 to 4.00	8.00 to 10.00	1.00 to 6.00	2.00 to 4.00
Adiantum	1.00 to 1.50	1.00 to 2.00	1.50 to 1.00	1.00 to 1.25
Whitmanii Fronds	4.00 to 6.00 to 6.00 to 6.00 to 6.00
Smilax to 15.00	15.00 to 20.00 to 15.00	10.00 to 15.00
Asparagus Plumosus, strings	25.00 to 50.00	50.00 to 75.00	50.00 to 60.00	30.00 to 50.00
" " & Sprea. (100 bchs.)	25.00 to 50.00	30.00 to 50.00	25.00 to 50.00	30.00 to 50.00

H. G. BERNING
Wholesale Florist
1402 Pine Street, ST. LOUIS, MO.

J. B. Murdoch & Co.
Wholesale Florists
FLORISTS' SUPPLIES
714 Penn Ave., PITTSBURG, PA.
Long Distance Phone 1435 Court.

Alex Mann, Jr. Co., Inc.
Wholesale Dealer in
Florists' Supplies and Cut Flowers
White Doves, \$0.00 per doz.
Galax Leaves.
1125 Polk Street, San Francisco, Cal.

REED & KELLER
122 West 25th St., New York
Florists' Supplies
We manufacture all our
Metal Designs, Baskets, Wire Work & Novelties
and are dealers in
Glassware Decorative Greens and Florists' Requisites.

HEATING APPARATUS

Lord & Burnham Co.,
1133 Broadway, New York.
For page see List of Advertisers.

Pierson U-Bar Co., 1 Madison Sq., N. Y.
For page see List of Advertisers.

Hitchings & Co., 1170 Broadway, N. Y.
For page see List of Advertisers.

John A. Payne, 260-274 Culver Ave., Jersey City, N. J.
For page see List of Advertisers.

HOT-BED SASH

The A. T. Stearns Lumber Co., Nepouset, Mass.
For page see List of Advertisers.

Pierson U-Bar Co., 1 Madison Sq., N. Y.
For page see List of Advertisers.

Hitchings & Co., 1170 Broadway, N. Y.
For page see List of Advertisers.

Lord & Burnham Co., 1133 Broadway, N. Y.
For page see List of Advertisers.

Foley Mfg. Co., between Western Ave. and 26th St., Chicago, Ill.

INSECTICIDES.

Andrew Wilson, Summit, N. J. Dept. 8.
Plant Oil.
For page see List of Advertisers.

Carmau's Anti-pest.
Perfection Chemical Co., Flushing, N. Y.
W. W. Rawson & Co., 5 Union St., Boston.
For page see List of Advertisers.

Nicotelle kills all greenhouse pests.
P. R. Palethorpe Co.,
Eleventh St., Owensboro, Ky.
For page see List of Advertisers.

Nicotine Mfg. Co., St. Louis, Mo.
Nikoteen.

For Sale—Tobacco Stems and Tobacco Dust. Stems, 1-2c. per lb. in bale lots. Dust, 2c. per lb. in case lots. Weight of bale or case 300 to 400 lbs. each. S. R. Levy, Binghamton, N. Y.

JAPANA CUT FLOWER HOLDER

M. V. Garnsey, 130 So. Walola Av., La Grange, Ill. Dept. J.
For page see List of Advertisers.

We Have Them.
Send for New Illustrated Catalogue.
H. Bayersdorfer & Co.,
1129 Arch St., Philadelphia, Pa.

KENTIAS

A. Leuthy & Co., Roslindale, Mass.
For page see List of Advertisers.

Godfrey Aschmann, 1012 W. Ontario St., Philadelphia.
For page see List of Advertisers.

LEADING RETAIL FLORISTS

Park Floral Co., Denver, Colo.
For page see List of Advertisers.

George H. Cooke, Washington, D. C.
For page see List of Advertisers.

Gude Bros. Co., 1214 F St., Washington, D. C.
For page see List of Advertisers.

Atlanta Floral Co., Atlanta, Ga.
For page see List of Advertisers.

P. J. Hauswirth, 232 Michigan Ave., Chicago.
For page see List of Advertisers.

William J. Smyth, Michigan Ave. and 31st St., Chicago.
For page see List of Advertisers.

Jacob Schulz, 644 4th Ave., Louisville, Ky.
For page see List of Advertisers.

Thos. F. Galvin, 124 Tremont St., Boston.
For page see List of Advertisers.

Julius A. Zinn, 2 Beacon St., Boston.
For page see List of Advertisers.

Houghton & Clark, 396 Boylston St., Boston.
For page see List of Advertisers.

Sidney Hoffman, 59-61 Massachusetts Ave., Boston.
For page see List of Advertisers.

LEADING RETAIL FLORISTS—

J. Breitmeyer's Sons, Detroit, Mich.
For page see List of Advertisers.

Samuel Murray, 1017 Broadway, Kansas City, Mo.
For page see List of Advertisers.

Wm. L. Rock Flower Co., 1116 Walnut St., Kansas City, Mo.
For page see List of Advertisers.

Fred C. Weber, 4326 Olive St., St. Louis, Mo.
For page see List of Advertisers.

H. G. Eyrea, 11 N. Pearl St., Albany, N. Y.
For page see List of Advertisers.

David Clarke's Sons, 2139-2141 Broadway, New York.
For page see List of Advertisers.

W. H. Donohoe, 17 E. 28th St., New York.
For page see List of Advertisers.

Alex. McConnell, New York.
For page see List of Advertisers.

Robert G. Wilson, Fulton St. and Greene Ave., Brooklyn, N. Y.
For page see List of Advertisers.

Thomas Young, Jr., New York.
For page see List of Advertisers.

Young & Nugent, 42 W. 28th St., N. Y.
For page see List of Advertisers.

Mills the Florist, Jacksonville, Fla.
Telegraph or mail orders promptly filled. Long distance telephone connections.

NEW AND RARE PLANTS

Rose Hill Nurseries, New Rochelle, N. Y.
For page see List of Advertisers.

NICO-FUME

Kentucky Tobacco Product Co., Louisville, Ky.

NURSERY STOCK

John Waterer & Sons, Ltd., American Nursery, Bagshot, England.
For page see List of Advertisers.

New England Nurseries, Bedford, Mass. Shrubs, Roses and Herbaceous Perennials. Specimen Pyramidal Box.
For page see List of Advertisers.

Bay State Nurseries, N. Abington, Mass. Herbaceous Perennials, Hardy Ornamental Trees.
For page see List of Advertisers.

Cleary's Horticultural Co., 62 Vesey St., New York.
For page see List of Advertisers.

P. Onwerkerk, 216 Jane St., Weehawken Heights, N. J.
Holland Nursery Stock for Forcing.
For page see List of Advertisers.

Nursery Stock. N. F. McCarthy & Co., 84 Hawley St., Boston, Mass.

A. Van Leeuwen, Jr. H. H. De Wildt.
THE HORTICULTURAL CO.
Landscape Department, Office & Nurseries, Worcester, Mass. Castle, N. C.
What have you got to sell?
We are buying.

ORCHID PLANTS

Lager & Hurrell, Summit, N. J.
For page see List of Advertisers.

Sander, St. Albans, England.
Importers, Exporters, Growers, Hybridists
For page see List of Advertisers.

Julius Roehrs Co., Rutherford, N. J.
For page see List of Advertisers.

Carrillo & Baldwin, Secaucus, N. J.
For page see List of Advertisers.

Jos. A. Manda, 191 Valley Road, W. Orange, N. J.
For page see List of Advertisers.

Ordonez Bros., Madison, N. J., Box 105.
For page see List of Advertisers.

PALMS

A. Leuthy & Co., Perkins St. Nurseries, Roslindale, Mass.
For page see List of Advertisers.

Robert Craig Co., Market and 49th Sts., Philadelphia, Pa.
For page see List of Advertisers.

Kentla, Phoenix, etc., all sizes. Write for new price list. Julius Roehrs Co., Rutherford, N. J.

PAINT AND PUTTY

PAINT AND PUTTY: Ideal Greenhouse lead; Special Greenhouse Putty. Lord & Burnham, 1133 Broadway, N. Y.

PANSY PLANTS.

Choice pansy plants, 50c. per 100; \$4.00 per 1000. Cash. Aug. Ziruglebel, Needham, Mass.

PATENTS

Siggers & Siggers, Washington, D. C.
For page see List of Advertisers.

PEAT

Orchid peat, Rotted peat, Azalea peat, Leaf-Mould, Live Sphagnum moss, Baled Sphagnum moss, Green Clump moss, etc. Jobbers' list on application. C. W. Brownell & Co., Walden, N. Y.

PEONIES

One of the finest collections in America. Send 25 cts. in stamps for new edition of Peony Manual. C. S. Harrison's Select Nursery, York, Neb.

PHLOXES

Send 25 cts. in stamps for Phlox Manual. Fine mixed phloxes \$1.50 per 100. C. S. Harrison's Select Nursery, York, Neb.

PIPE AND FITTINGS

Foley Mfg. Co., between Western Ave. and 26th St., Chicago, Ill.

PIPE AND FITTINGS. Cast Iron and Wrought Pipe, Valves, Elbows, Pipe Hooks, Automatic Air Headers, etc. Lord & Burnham, 1133 Broadway, N. Y.

PLANT BED CLOTH

Mineralized Rubber Co., 18 Cliff St., N. Y.
For page see List of Advertisers.

POT HANGERS

Pot hangers, Kramer's \$1 doz. by exp., \$1.25 by mail. I. N. Kramer & Son, Cedar Rapids, Ia.

PRUNING SHEARS

Rhodes Mfg. Co., Grand Rapids, Mich. Dept. R.

RAFFIA

We Have It.
Send for New Illustrated Catalogue.
H. Bayersdorfer & Co.,
1129 Arch St., Philadelphia, Pa.

Raffia (colored), 20 beautiful shades Samples free. R. M. Comey Co., Camden, N. J.; 810 Washburn Ave., Chicago, Ill.

RHODODENDRONS

John Waterer & Sons, Ltd., American Nursery, Bagshot, England.
For page see List of Advertisers.

ROSES

Julius Roehrs Co., Rutherford, N. J. Rambler Rose, Newport Fairy.
For page see List of Advertisers.

New England Nurseries, Inc., Bedford, Mass.
Roses for Forcing.
For page see List of Advertisers.

Bay State Nurseries, N. Abington, Mass.
For page see List of Advertisers.

Ellwanger & Barry, Rochester, N. Y. Hardy Roses.
For page see List of Advertisers.

For List of Advertisers See Page 124

List of Advertisers

Table listing advertisers and their page numbers, including Allen J. K., American Nursery, Aschmann Godfrey, Atlanta Floral Co., Bambrick Thos., Barrows H. H. & Sons, Barr Floral Co., Bayersdorfer H. & Co., Bay State Nurseries, Beaven E. A., Berning H. G., Boddington A. T., Boston Florist Letter Co., Boston Plate and Window Glass Co., Bosch, Felix, Braslan Seed Growers Co., Breck Joseph & Sons, Breitmeyer's J. Sons, Bridgeman's Seed Warehouse, Burpee W. A. & Co., Carrillo & Baldwin, Cassidy L., Castle Co., Chicago Carnation Co., Clarke's David, Sons, Cleary's Horticultural Co., Conard & Jones Co., Cook John, Cooke G. H., Cowee A., Craig, Robt. Co., Craig, W. P., Dailedouze Bros., Donohoe W. H., Dornier F. Sons & Co., Dreer H. A., Dysart R. J., Edgar, W. W. Co., Edwards Folding Box Co., Elliott Wm. & Sons, Ellsanger & Barry, Erringer, J. W., Esler, J. G., Ernest W. H., Eyres, Farquhar K. & J. Co., Fenrich J. S., Field H. W., Fisher Peter, Fiske, H. E. Seed Co., Foley Mfg. Co., Ford Bros., Froment H. E., Fuller J., Gavin Thos. F., Garnsey M. V., Getmore Box Factory, Grey T. J. Co., Gude Bros. Co., Gutman Alex. J., Guttman & Weber, Hall Asso., Haines, J. E., Haley J., Hammond Paint & Slug Shot Works, Hartmann Hjalmar & Co., Hauswirth P. J., Herbert David & Sons, Hews A. H. & Co., Hicks Frank S. & Co., Hilfinger Bros., Hill, The E. G. Co., Hitchings & Co., Hoffman, H. N., Hoffman, H., Horan E. C., Houghton & Clark, Jacobs S. & Sons, Jahr, H. A., Kasting W. F., Kervan Co., The, Kessler, P. F., Kimbely Frank H., King Cons. Co., Koral Mfg. Co., Kuebler Wm. H., Lager & Hurrell, Langjahr, Alfred H., Lehman Bros., Leunthy A. & Co., Lord & Burnham Co., Lutton W. H., Manda Jos. A., Mann, Alex. Jr. Co., McCarthy N. F. & Co., McConnell Alex., McKellar Charles W., McKissick, W. E., McManus Jas., Michell H. F. Co., Michigan Cut Flower Exchange, Millang Charles, Millang Frank, Mineralized Rubber Co., Moltz, A., Moninger J. C., Moore, Hentz & Nash, Moore, J. L., Morse C. C. & Co., Murdoch J. B. & Co., Murray Samuel, New England Nurseries, Nicholson Wm., Niessen Leo. Co., Ordonez Bros., Ouwerkerk P., Paithorpe P. R. Co., Park Floral Co., Payne John A., Pennock-Meehan Co., Perfection Chemical Co., Perkins St. Nurseries, Philadelphia Plant Exchange, Pierson A. N., Pierson F. R. Co., Pierson U Bar Co., Pratt B. G. Co., Pulverized Manure Co., Rawson W. W. & Co., Ray T. J. & Co., Raynor John L., Reed & Keller, Reid Edw., Reinberg Peter, Rickards Bros., Robinson H. M. & Co., Rock Wm. L. Flo. Co., Roehrs Julius Co., Rolker August & Sons, Ruse Hill Nurseries, Rusconi D., Sander & Son., Scheepers John & Co., Schultheis Anton, Schulz Jacob, Scott, John., Scott Robt. & Son., Sheridan W. F., Siggers & Siggers, Sim. Wm., Situations & Wants, Skidelsky S. S., Slinn B. S., Jr., Smyth Wm. J., Standard Plate Glass Co., Stearns A. T. Lumber Co., Stumpff & Walter Co., Thorburn J. M. & Co., Totty Chase, H., Traendly & Schenck, Valentine, J. A., Velhuys K., Vick's Jas. Sons, Vincent R. Jr. & Sons, Waterer John & Sons, Weber F. C., Weber H. & Sons, Welch Bros., Wilholt, R., Wilson, Andrew, Winters, E. F. Co., Wittstaetter R., Woodrow, Sam'l A., Yokohama Nursery Co., Young A. L., Young John, Young, Thos. Jr., Young & Nugent, Zangen O. V., Zinn, J. A.

New Offers in This Issue.

- AZALEAS. August Rolker & Sons, New York, 31 Barclay St., or P. O. Box 752. For page see List of Advertisers.
CARNATION AFTERGLOW. R. Witterstaetter, Sta. E., Cincinnati, O. For page see List of Advertisers.
CARNATION BEACON. Peter Fisher, Ellis, Mass. For page see List of Advertisers.
CARNATION CUTTINGS. Guttman & Weber, 43 W. 28th St., New York. For page see List of Advertisers.
CARNATION CUTTINGS AND PLANTS. Chicago Carnation Co., Joliet, Ill. For page see List of Advertisers.
CARNATION PRESIDENT SEELYE. H. W. Field, Northampton, Mass. For page see List of Advertisers.
CARNATIONS. F. H. Kimberly, 631 Townsend Ave., New Haven, Conn. For page see List of Advertisers.
CARNATIONS. S. S. Skidelsky, 1741 N. 18th St., Phila. For page see List of Advertisers.
CARNATIONS IMPERIAL AND PINK IMPERIAL. John E. Haines, Bethlehem, Pa. For page see List of Advertisers.
CARNATIONS ROOTED CUTTINGS. H. N. Hoffman, Elmira, N. Y. For page see List of Advertisers.
CARNATION WHITE FAIR MAID. Welch Bros., 225 Devonshire St., Boston. For page see List of Advertisers.
CARNATION WINSOR. A. N. Pierson, Cromwell, Ct. For page see List of Advertisers.
CARTER'S DOUBLE BLUE LOBELIA. Jos. Fuller, 31 Orchard St., Leominster, Mass. For page see List of Advertisers.
CONCRETE PLANT PROTECTOR FOR TOMATO GROWING. J. H. Haley, Munnith, Mich. For page see List of Advertisers.
DAHLIA CHAS. LANIER. R. & J. Farquhar Co., 6 and 7 S. Market St., Boston. For page see List of Advertisers.
ELECTRIC CIRCULATOR, HEATING APPARATUS. The Castle Co., 170 Summer St., Boston. For page see List of Advertisers.
GALAX. FERNS. T. J. Ray & Co., Elk Park, N. C. For page see List of Advertisers.
GERANIUM NOVELTIES. R. Vincent, Jr. & Sons Co., White Marsh, Maryland. For page see List of Advertisers.
HELP FURNISHED. Thos. H. Bambrick, 34 S. 7th St., Phila. For page see List of Advertisers.
HORICUM. Hammond's Paint & S. S. Wks., Fishkill-on-Hudson, N. Y. For page see List of Advertisers.
MADE-UP PLANTS KENTIA FORTERIANA. Philadelphia Plant Exchange, 829 Market St., Philadelphia. For page see List of Advertisers.
ROSE MRS. JARDINE. S. S. Pennock-Meehan Co., Philadelphia. For page see List of Advertisers.
ROSE MRS. JARDINE. W. P. Craig, 1305 Filbert St., Philadelphia. For page see List of Advertisers.
ROSES FOR FORCING. Bay State Nurseries, N. Abington, Mass. For page see List of Advertisers.

I HAVE THE LARGEST LINE OF CAST IRON AND STEEL GREENHOUSE BOILERS

A prominent florist says - "Far Ahead of Any steam boiler that I have ever seen or used in regard to heating, and is very economical in coal." This is the verdict of an old time florist. Do not decide until you have my estimate on boiler or heating material.

JOHN A. PAYNE, Horticultural Architect and Builder. Main Office and Factory: 260-274 Culver Ave., Jersey City, N.J. Sash opening apparatus and all kinds of greenhouse structural material.

The FLORISTS' HAIL ASSOCIATION OF AMERICA, insurer of 28,000,000 sq. ft. of glass. For particulars address John C. Esler, Sec'y, Saddle River, N.J.

SITUATIONS WANTED

GOOD MEN When you need good men, skilled or unskilled, Write: THOS. H. BAMBRICK 34 South 7th Street Philadelphia Help of all kinds, including that for Florists, Nurserymen, Seedsmen and the Horticultural trade generally.

WANTED-Position in general greenhouse work; single; age 35; lifelong experience; understand every detail of growing, etc. Address P. A., care HORTICULTURE.

WANTED-Position with reliable wholesale or retail seed house as seedsmen; six years' reference with trustworthy seed firms; nationality, Scotch. Address Seeds, care Horticulture.

SITUATION WANTED in general greenhouse work; single, age 35, five years' experience, commercial. Address W. W., care HORTICULTURE.

FOR SALE

FOR SALE-On account of the recent death of my husband, I desire to sell our green house property located at Farmington, Conn., consisting of seven greenhouses, covering 12,000 square feet of ground, planted principally to carnations and violets. Stock in excellent condition; free from disease and showing lots of bloom at present time. Business established twenty-eight years and a ready market for entire output. With two acres of land, and a six-roomed cottage, with all modern improvements; stable, sheds, implements, etc. A splendid opportunity to a quick buyer. Address for further information, terms, etc., to Mrs. Hugh Chesney, Farmington, Conn.

FOR SALE-A large consignment of 16x24 double thick American glass, A and B quality. For further information write Parschelsky Brothers, 59 Montrose Avenue, Brooklyn, N. Y.

Is Your Name In The Above List? If Not, Why Not?

**GREENHOUSES BUILDING OR CON-
TEMPLATED.**

Ottawa, Kan.—John Lester, house, 22x86.
 Pocasset, R. I.—Thomas Parillo, one house.
 Petersburg, Va.—A. W. Bryan, range of houses.
 Rutledge, Pa.—E. F. Hauser, range of houses.
 Water Mill, N. Y.—F. E. Benedict, one house.
 Nahant, Mass.—Thomas Roland, house, 45x140.
 Woburn, Mass.—Adam Foster, two houses, 50x100.
 Green Bay, Wis.—Chas. De Clerc, range of houses.
 Oaklawn, R. I.—Wm. Hay, rose house, 45x300.
 Attica, N. Y.—A. J. Pauley, two houses, 26x100, 26x200.
 Chicago, Ill.—Peter Reinberg, range of carnation houses; Edw. Meuret, range of houses.

BETWEEN YOU AND ME, What do you think of the Buyers' Directory and Ready Reference Guide of HORTICULTURE? I always look it over before I do any buying.

**GREENHOUSE
GLASS**

Cheaper Now Than For Years

We are taking contracts for next Spring delivery.

WRITE FOR OUR PRICES

**STANDARD PLATE GLASS
COMPANY**

26-30 Sudbury St. 61-63 Portland St.
 BOSTON, MASS.

PATENTS
 Trademarks and Copyrights

Send other business direct to Washington. Saves time and insures better service. Personal attention guaranteed. Twenty-five years' active service. SPECIALTY: "Working on the Failure of Others."

SIGGERS & SIGGERS

PATENT LAWYERS

Box 9, National Union Building
 Washington, D. C.



**Cattle Manure
In Bags** Shredded or Pulverized

Best and safest manure for florists and greenhouse use, absolutely pure, no waste, no danger. Write for circulars and prices.

The Pulverized Manure Co.,
 31 Union Stock Yards, Chicago

"SCALECIDE"
HAS MADE SPRAYING EASY THEN WHY NEGLECT YOUR TREES?
 The N. Y. Herald, November 17, '07, says: "The chances are about a hundred to one that you have the San Jose Scale on your place and do not know it," and advises the use of "SCALECIDE." This is good advice. "SCALECIDE" has been tested and tried, and found thoroughly effective. The same yesterday, to-day, and all the time. One gallon makes 15 to 20, ready to use, by simply adding water.
 Prices: 1 gal., \$1.00; 5 gal., \$3.25; 10 gal., 6.00; 50 gal. bbl., \$25.00, F. O. B. our factory. Order to-day. Write for booklet Wand free sample.
B. G. PRATT CO., Mfg. Chemists,
 11 Broadway, New York City.

"HORICUM"

TRADE MARK

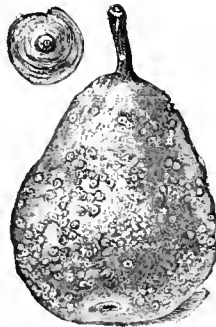

San Jose Scale on a Pear.

"HORICUM"
KILLS SAN JOSE SCALE

Directions for Use.

This preparation is Lime, Sulphur and Salt, making a concentrated Poly-sulphide of Calcium. The Salt adds to the adhesive properties, but the destructiveness to Scale Life lies in the Calcium Sulphide. Aside from its ability to destroy San Jose Scale, Horicum is a Fungicide, preventing the free development of fungoid troubles.

Shake package thoroughly or take the top off. The color in its concentrated form is a deep bronze green. Do not pour off the clear liquor only, stir the Horicum from the bottom of the package, add 20 parts of water (hot, if you can get it) for ordinary use. For a stronger dilution when the growth is all dormant, use 10 parts of water only (hot, if you have it) and spray thoroughly. By grading your dilution you make it any desired strength. Specific gravity, 1.50. Total Poly-sulphides, 30% by weight. Send for pamphlets to

HAMMOND'S SLUG SHOT WORKS

Fishkill-on-Hudson, N. Y.

Kills San Jose

Wilson's Plant Oil

Kills all insects infesting greenhouse plants.

TRY IT.

A. Herrington says:—Your Plant Oil is certainly the most effective scale killer I have ever tried.

PRICES: 1-2 pint cans, 25c; pints, 40c; quart, 75c; 2 quarts, \$1.25; gallon \$2.00; five gallons, \$9.00 Cash with order.

ANDREW WILSON, Dept. 8, Summit, N. J.

Selling Agents for New England, R. & J. FARQUHAR & CO.,
 6 and 7 South Market St., Boston, Mass.



**The Best
Bug Killer and
Bloom Saver**

For PROOF

Write to

P. R. Palethorpe Co.
 OWENSBORO, KY.



Standard Flower . . POTTS

If your greenhouses are within 500 miles of the Capitol, write us, we can save you money

W. H. ERNEST,

28th and M Street WASHINGTON D. C.

In ordering goods please add, "I saw it in HORTICULTURE."

GARMAN'S ANTIPEST

For the Garden, Orchard and Greenhouse.

Non-poisonous and harmless to vegetation.

Kills Green Fly, Aphides, Bark Lice, Thrip, Mealy Bug, Red Spider, Scale, Wire Worms, Ants and Slugs.

This is the Grower's Friend, handy to use, cheap and effective, mixes readily in water. Destroys all insect pests, and keeps down filth. Circulars on application \$1.50 per gallon. Also in quarts, half gallons and in bulk.

PERFECTION CHEMICAL CO.,
 FLUSHING, N. Y.

Eastern Agents:

W. W. RAWSON & CO., 5 Union St. Boston, Mass.

STANDARD FLOWER POTTS

Packed in small crates, easy to handle.

Price per crate	Price per crate	
1500 2 in. pots in crate \$4.88	120 7 in. pots in crate \$4.20	
1500 3 1/4 " " " 5.25	60 8 " " " 3.00	
1500 4 " " " 6.00	HAND MADE	
1000 3 " " " 5.00	48 9 in. pots in crate \$3.60	
800 3 1/2 " " " 5.80	48 10 " " " 4.80	
500 4 " " " 4.50	24 11 " " " 4.80	
320 5 " " " 4.52	24 12 " " " 4.80	
144 6 " " " 3.16	6 16 " " " 4.50	

Seed pans, same price as pots. Send for price list of Cylinders for Cut flowers, Hanging Baskets, Lawn Vases, etc. Ten per cent. off for cash with order. Address **Hilfinger Bros., Pottery, Fort Edward, N. Y.** August Holker & Sons, Agts., 31 Barclay St., N. Y. City.

WILLIAM H. LUTTON

HORTICULTURAL ARCHITECT AND BUILDER

WEST SIDE AVENUE STATION (C. R. R. OF N. J.)
JERSEY CITY, N. J.

Have not been established 50 years, but long enough to convince the wide-awake Florist and Gardener that it is to his interest to place his work in thoroughly practical hands.

(150,000 sq. ft. glass erected in 1907 will substantiate this claim)

And why not? My material is the best that can be secured. My iron frame construction has every modern feature that years of practical experience can embody.

AND THEN THERE IS THE COST TO BE CONSIDERED.

Why not let us take up this important question now?

CYPRESS SASH BARS
 82 feet or longer
HOT BED SASH
PECKY CYPRESS BENCH LUMBER

GREENHOUSES
 ERECTED AND EQUIPPED COMPLETE IF DESIRED

Write for Circular "D" and Prices

The A. T. STEARNS LUMBER CO.
 NEPONSET, BOSTON, MASS.

S. JACOBS & SONS
 Manufacturers of GULF CYPRESS

GREENHOUSE MATERIAL
 Jobbers of
Glass, Boilers, Pipes, Etc.
 Catalogue and Prices Upon Request.

1365-1379 Flushing Ave.
BROOKLYN, - NEW YORK

ANCHOR GREENHOUSE HOSE
 WEARS WELL.

PLANT BED CLOTH

Protects from Cold and Dampness.

MINERALIZED RUBBER CO.

48 Cliff Street. New York

GREENHOUSE CONSTRUCTION LUMBER

John C. Moninger Co.

417 E. Blackhawk St., CHICAGO

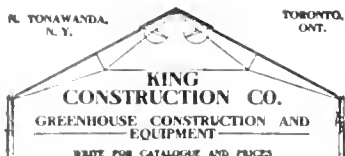

GREENHOUSE MATERIAL AND FITTINGS

WRITE FOR PRICES

"1908 MODEL" VENTILATING MACHINE

SIMPLEST AND MOST DURABLE MACHINE
 NOW ON THE MARKET; EASILY ERECTED

I. CASSIDY,
 DESIGNER AND BUILDER

Summer Ave. & Erie R. R.
 NEWARK, - - - N. J.

INSURANCE

of your plants from **FREEZING** in cold weather
 at a trifling cost. Use a celebrated

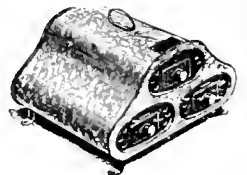

LEHMAN WAGON HEATER

There is no danger of fire; no smoke, dirt or gases to injure plants. They burn **Lehman Coal**, which costs less than 1/2 cent per hour.

Over 400,000 Lehman heaters are in actual use by **Florists, Horsemen, Agriculturists** and **Physicians**. Have you one? Write for new booklet with prices to-day.

LEHMAN BROS.

Manufacturers

10 Bond St., NEW YORK
 BEWARE OF IMITATIONS.

J. W. ERRINGER

Gen. West. Sales Agent

45 E. Congress St., CHICAGO
 Mention "Horticulture" when writing.

NOW IS THE RIGHT TIME TO FIGURE

MATERIAL AND PLAN FOR THE BUILDINGS OF THIS YEAR

FOLEY'S } QUALITY AND WORK THE BEST
 PRICES RIGHT AND LOWEST.
 ESTIMATES WILL PROVE. TRY US.

Foley Ventilating Apparatus Unequaled

Will Ventilate any Size of House Easily. Send for Circular.

THE FOLEY MFG. CO. Western Ave. 25th & 26th Sts. CHICAGO

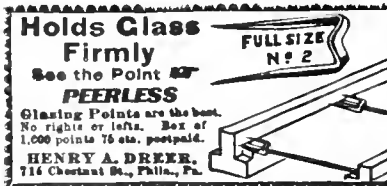

BOSTON PLATE & WINDOW GLASS CO.

GREENHOUSE GLASS

German and American

261 to 287 A St., BOSTON 20-22 Canal St.

In ordering goods please add, "I saw it in HORTICULTURE"

THE "BREAD AND BUTTER" CARNATION

is an absolute necessity to the florist. To be entitled to the name a variety must have all the good qualities

BUT

in addition it must also have been grown in

A BREAD AND BUTTER HOUSE

for imperfect circulation, irregular temperatures, wasteful coal consumption and other concomitants of a defective heating system will get away every time with all the butter and most of the bread.

Are You Satisfied to Put In Another Year Under Such Conditions?

WE can help you. There is no hot-water system so good that we cannot improve its effectiveness and lessen the cost by installing our

ELECTRIC CIRCULATOR

Some systems are so antiquated, unreliable and extravagant that it is cheaper to throw them out and put in a "Bread and Butter" heating outfit.

It costs you nothing to consult us. We are prepared to show you how to hitch up the Bread and Butter Carnation with the Electric Hot Water Circulator so that you can make money.

"A PENNY SAVED IS TWO EARNED"

All **YOU** need to do, is to send your address — with inquiries to

THE CASTLE CO.

170 SUMMER STREET - - BOSTON

H AND CO

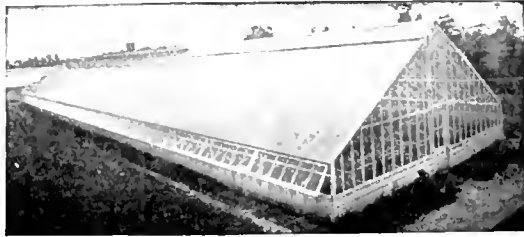

If You Contemplate Building a GREENHOUSE

Write Us for Prices on

- The house erected complete, or
- The Ironwork and Woodwork.
- The Heating Apparatus Erected.
- The Boiler.
- The Ventilating Apparatus, or any part you desire to purchase.

HITCHINGS AND CO.

GREENHOUSE DESIGNERS AND BUILDERS.

Manufacturers of Heating and Ventilating Apparatus.

1170 Broadway, NEW YORK.

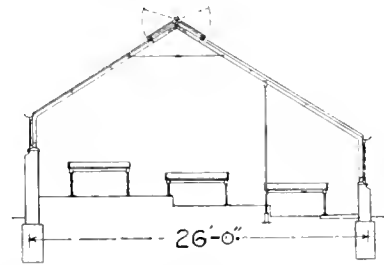

WHEN YOU BUILD THAT ROSE HOUSE

lay it out with sidewalks. It is a great advantage in reaching each plant on the side benches, without the danger of injuring any in working among them. But first, be sure of the right construction! For endurance and unquestionable practicalness of every construction point, our *Sectional Iron Frame Houses* fill every growing requirement.

We make every part of a greenhouse but the glass. We sell any part.

LORD & BURNHAM CO.

1133 BROADWAY, cor. 26th Street, N. Y.

BOSTON Branch: 819 Tremont Building

PHILADELPHIA Branch: 1215 Filbert St.

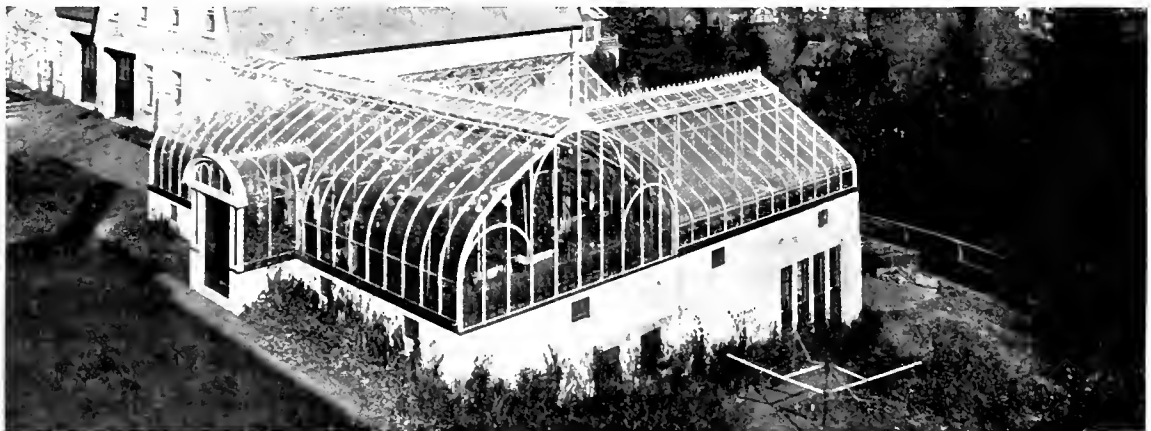

A very unusual proposition, this. We had two exacting things to overcome. The only available location at the time, was just across the drive from the residence, which is so situated that in the winter months, it would shade the greenhouses. Then the ground sloped off so rapidly that it necessitated high masonry to bring the houses to the grade level of the drive. You see how this was accomplished. The space below makes a good workroom and an ideal place for the storage of bulbs, etc. Now about the shade question. The gardener has been employed on several prominent places where there were houses of other constructions, and he flatly declares that the U-Bar houses, because they are so light, give him just as good results, *even with this handicap of shade*, as other houses under the very best of location advantages. So that is what the curved eave, light structural members and wide glass spacing means from the practical, productive side alone. It is certainly a tremendous advantage to have a house that gives to your plants such a large proportion of all the available light. But know every U-Bar strong point—send for the catalog. Pierson U-Bar Company, Designers and Builders *U-Bar Greenhouses*, Metropolitan Building, 4th Avenue and 23rd Street, New York.



HORTICULTURE

Vol. VII.

FEBRUARY 1, 1908

No. 5



MARCELLUS A. PATTEN

President-elect American Carnation Society.

*Devoted to the
FLORIST, PLANTSMAN,
LANDSCAPE GARDENER
and
Kindred Interests*

*Published
EVERY SATURDAY
At 11 Hamilton Place,
BOSTON, MASS.
Subscription, \$1.00*

CARNATION CUTTINGS DEPEND

on receiving only STRONG and HEALTHY cuttings when you order from US.
WE HAVE ONLY THE NICEST AND BEST VARIETIES.

Write for further information to

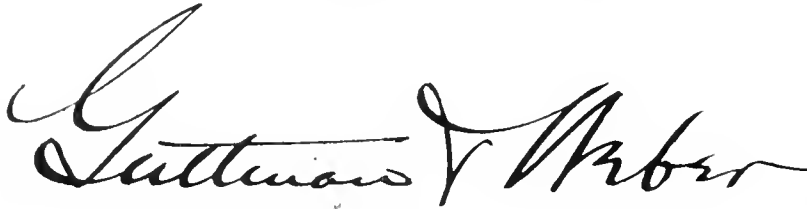

THE WHOLESALE FLORIST OF NEW YORK
43 West 28th Street

GROWER
Lynbrook, L. I.

Victory Imperial
Pink Imperial
Aristocrat Winsor
White Perfection
Welcome Lieut. Perry
Rose Pink Enchantress, etc.

Rooted Carnation Cuttings

<u>Pink</u>	100	1000
Aristocrat.....	\$6.00	\$50.00
Winsor.....	6.00	50.00
Rose Pink Enchantress.....	3.50	30.00
Enchantress.....	3.00	25.00
Lawson.....	2.50	20.00
Joost.....	2.00	15.00
<u>White</u>		
White Perfection.....	3.00	25.00
“ Enchantress.....	6.00	50.00
“ Lawson.....	3.00	25.00
Queen.....	2.00	18.00
Boston Market.....	2.00	18.00
Louise.....	2.00	18.00
Lt. Peary.....	3.00	25.00
Bountiful.....	2.50	20.00

<u>Red</u>	100	1000
Beacon.....	6.00	50.00
Victory.....	3.00	25.00
Rob't Craig.....	3.00	25.00
Flamingo.....	2.50	20.00

<u>Miscellaneous</u>	100	1000
Patten.....	2.50	20.00
Harry Fenn.....	2.50	20.00
Harlowarden.....	2.50	20.00

Stock Guaranteed—Prompt Deliveries

THE LEO NIESSEN CO.
WHOLESALE FLORISTS
1209 Arch St., PHILADELPHIA

WHITE FAIR MAID

Rooted Cuttings
\$10 per 100. \$75 per 1000
WELCH BROS., 226 Devonshire St.
Boston, Mass.

SPECIAL ATTENTION PRIVATE GARDENERS.

CARNATION CUTTINGS AND PLANTS	2 1/2" pots	Per 100	Per 1000	Per 1000
Andrew Carnegie, scarlet Harlowarden the best scarlet for you to grow.		\$12.00	\$100.00	\$15.00
Aristocrat, beautiful cerise,		6.00	50.00	8.00
Welcome silvery pink, very good, long stems,		6.00	50.00	8.00
Winsor, silvery pink, good producer,		6.00	50.00	8.00
Beacon, orange scarlet,		6.00	50.00	8.00
Red Chief scarlet, produces 2-1 of any other scarlet,		6.00	50.00	8.00
White Enchantress, large stock of the true pure white,		6.00	50.00	8.00
Rose Pink Enchantress, true stock,		3.00	25.00	5.00
White Perfection,		3.00	25.00	5.00
Daybreak Lawson or Melody,		3.00	25.00	5.00
Victory good scarlet,		3.00	25.00	5.00
Enchantress, large stock,		2.50	20.00	5.00

Special Prices on Large Quantities. Send us your Order
CHICAGO CARNATION CO. (A. T. PYFER, MGR.) Joliet, Ill.

CARNATIONS

— NOW READY —

Afterglow, the finest pink, and Britannia, the English scarlet, \$12.00 per 100.
Aristocrat, Winsor, Imperial, Beacon and Pink Imperial, all at \$6 per 100, \$50 per 1000.
White Perfection, Rob't Craig, Victory, Lady Bountiful, P. S. P. A. Patten and Enchantress, \$3 per 100, \$25 per 1000.
Queen, Variegated Lawson, Fair Maid, Peary and Mrs. Lawson, \$2.50 per 100, \$20.00 per 1000.

Booking orders for GRAFTED ROSE STOCK of all standard varieties.

CHARLES H. TOTT

Send for complete list. MADISON, N. J.

Winsor Carnations.

From 6000 plants we have plenty of exceptionally fine stock, all 50,000 ready for shipment now. From 2 1/2 inch pots, \$7.00 per 100, \$60.00 per 1000. Rooted Cuttings, \$6.00 per 100, \$50.00 per 1000

A. N. PIERSON, - - Cromwell, Conn.

LLOYD IS THE REAL THING

The Carnation for every one to grow

LLOYD is a commercial white, with a fancy flower
The only ever-blooming, large-flowering white in existence
Will take the place of all other whites now in commerce. Every New Bedford grower has bought stock. Come and investigate.

**A KEEPER
A SHIPPER
A BLOOMER**

It will bring the shekels when all others fail

\$2 pr 12. \$12 pr 100. \$100 pr 1000
Unrooted Cuttings
\$6 per 100. \$50 per 1000.

H. A. JAHN

NEW BEDFORD, - - MASS.

Winsor and White Enchantress

**Strong Rooted Cuttings
Now Ready for Delivery**

WINSOR has proved to be the finest carnation in the light pink class. We sold a large quantity of it last year, but there will be a much larger sale for it this year. At the English Carnation Show held in December, it was the winner in the light pink class. It is doing well everywhere and will supplant everything in that color.

WHITE ENCHANTRESS will occupy the same position among white carnations that Enchantress does among flesh pinks. It has all the good qualities of the common Enchantress,—long stem, earliness, large size, freedom, etc. In our opinion, it is by far the best white carnation ever introduced.

We have a splendid stock of both Winsor and White Enchantress ready for immediate delivery, and will guarantee perfect satisfaction with the cuttings supplied. Do not wait, because the demand for these varieties is bound to be enormous. **Order early, while we can promise immediate delivery**, and secure gilt-edged stock. We have a large stock of both of these varieties, and all our cuttings are heel cuttings, taken from flowering stems. On account of the quantity that we are growing, we are not obliged to over-propagate, and our stock is in the most perfect and healthy condition.

Strong rooted cuttings from sand, \$6 per 100, \$50 per 1000. Extra strong transplanted cuttings from soil, \$7.50 per 100, \$60 per 1000. Strong established pot-grown plants \$9 per 100, \$75 per 1000.

F. R. PIERSON CO.

Tarrytown - on - Hudson, . . NEW YORK

The Wonders of 1907

IMPERIAL and PINK IMPERIAL CARNATIONS

The **Color** of "Imperial" is a variegation of delicate Pink similar to the shade in "Enchantress," with darker shades of pink. The **Color** of "Pink Imperial" is a most pleasing shade of Pink, one that has long been wanted in the cut flower market. The **Stems** of both these varieties run from three to four feet in length, are extra strong and have no equal in the Carnation of to-day. The **Calyxes** are good and strong and are practically non-bursters. The **Flowers** are well formed, run from three to four inches in diameter and are very fragrant. They are early, free and continuous bloomers, from October until late in July. Strong growers, every shoot a flower. Have shown them both at the November Shows with thirty inches of stem. Vases of blooms, shown at this fall's Show at Philadelphia, were pronounced the finest ever shown there. Both **JOHN E. HAINES, the leading scarlet** has proved to be all that was claimed for it. **Color**, most brilliant scarlet. **Stem**, from two to three feet in length, strong. **Calyx**, good and strong, non-bursters. **Flower**, three to three and one-half inches in diameter. **Productiveness**, unsurpassed, blooms 12 months of the year. No extra grass. Every shoot a flower. **Prices**, for selected cuttings of each variety, delivery commencing December, 1907, \$6.00 per 100, \$50.00 per 1000. Place your orders early. Visitors always welcome.

JOHN E. HAINES = Carnation Specialist = BETHLEHEM, PA.

ANNOUNCEMENT

Our new seedling carnation, **FOREADOR**, will not be disseminated until January 1909.

For further particulars address, **The H. WEBER & SONS CO., Oakland, Md.**



SPLIT PINKS

are never known by users of the M. & D Artificial Calyx.

\$ 1.75...per 100
15 00...per 1000
250 at 1000 rates.



Send for Sample. **MAXFIELD & DIMOND** Box 304-D Warren, R. I. Patented.

CARNATIONS WHITE ENCHANTRESS R. C.

This stock originated with and grown by me is the very best.
\$6.00 per 100, \$50.00 per 1000.

	Per 100	Per 1000
Enchantress, light pink.....	\$2.50	\$20.00
Lawson.....	2.00	15.00
Lord, light pink.....	2.00	15.00
Queen, white.....	2.00	15.00
The Belle, white.....	2.50	20.00

250 at 1000 rate. Orders of 1000 or more will be shipped prepaid on receipt of check.

Get your R. C. early and have blooms when others have none.

FRANK H. KIMBERLY
631 Townsend Avenue, NEW HAVEN, CONN

CARNATIONS ROOTED CUTTINGS

Winona, color, true clear pink, comes nearest to **Fiancee** but a different type flower. Growth on order of **Scott** but vastly improved in every respect. Early flowers in quantity and on long stems. Does not burst its calyx. Fine, shapely, active growth. In color and productiveness it is without an equal. Orders booked now and filled in strict rotation. \$12 per 100, \$100 per 1000.

White Perfection, pure white. We have a large stock. \$3 per 100, \$25 per 1000.

F. DORNER & SONS CO.
LA FAYETTE, IND.

In writing to Advertisers kindly mention Horticulture

NEW My Maryland ROSE

Best up-to-date commercial rose; read what others have to say about it.

Among the many new roses of the year there is none which has impressed us more as being worthy of a thorough trial. It has been exhibited only as 294, being a seedling raised by John Cook of Ba timore. A beautiful rose with an exquisite fragrance; in color it may be described as a soft salmon pink which brightens up beautifully as the bud opens. We are intending to plant this rose in quantity.

A. N. PIERSON, Cromwell, Conn.

In reply to your inquiry what we think of your new rose, My Maryland, we would say that after seeing others we still believe that you have the best new rose of modern times.

GUDE BROS., Washington, D. C.

Price 2 and 2½ inch pots, \$25 per 100; \$200 per 1000. Price 3 inch pots, \$5 per dozen.

JOHN COOK, 318 North Charles St. Baltimore, Md.

Hardy Roses

American Grown—Superior to Imported

We have unsold at the present time the following varieties—all field grown plants, grown in our nurseries at Rochester, N. Y.:

- | | |
|---------------------|----------------------|
| Anne de Diesbach | Prince Canille |
| Chlo | Ulrich Brunner |
| Fran Karl Druschki | Crimson Rambler |
| General Jacqueminot | White Rambler |
| John Hopper | Yellow Rambler |
| Mme. G. Lulzet | Philadelphia Rambler |
| Marshall P. Wilder | Common Sweet Briar |
| Mrs. John Laing | Mme. G. Bruant |
| Paul Neyron | Wichitana (The Type) |

These plants are in our storage cellars and can be shipped at any time. Prices on request.

ELLWANGER & BARRY

Nurserymen—Horticulturists

Mount Hope Nurseries, Rochester, N. Y.

Hardy Rhododendrons Azaleas Conifers, Clematis, H. P. Roses, Shrubs and Herbaceous Plants from our

HOLLAND NURSERIES

Prices Moderate

P. DUWERKERK, 216 Jane St., Weehawken Heights P. O. No. 1, Hoboken N. J.

AMERICAN NURSERY COMPANY

CONTAINING

FRED'K W. KEISEY New York City
P. & F. NURSERIES Sprin'gfield N. J.
BLOODGOOD NURSERIES, Flushing, L. I.
N. J. & L. I. NURSERIES.

We Can Supply Your Every Need. Write for Prices

SALES DEPARTMENT, 160 Broadway New York.

Established 40 Years

Rose Hill Nurseries

New and Rare Plants

NEW ROCHELLE, N. Y.

New York Office, Siebrecht Building, 425 Fifth Avenue

JOHN WATERER & SONS, Ld.

American Nursery, Bagshot, England

Are Specialists in the

[REALLY HARDY] VARIETIES

of Rhododendron Hybrids and in Select Varieties of Hardy Border Plants.

ROSES FOR FORCING Immeclate Delivery

Strong-Dormant Send for Prices and List
American Beauty, Clothilde Soupert, Gloire de Dijon, Hermosa, Kaiserin A. Victoria, Killarney, Liberty, La France Paman Cochet, Marechal Neil, Mrs. R. G. Scharman-Crawford, Marchioness of Londonderry, Souv. de la Palmaison, including all the leading varieties of Hybrid Perpetuals.

BAY STATE NURSERIES, No. Abington, Mass.

NEW ——— NEW

RAMBLER ROSE "NEWPORT FAIRY"

To be disseminated Spring, 1908. Ask for illustrated pamphlet and prices

JULIUS ROEHRS CO., Rutherford, N.J.

ROSES Selected Stock for Forcing

CRIMSON RAMBLER and DOROTHY PERKINS

3 to 4 ft. \$1.50 per 10, \$12.00 per 100; 4 to 5 ft. \$2.00 per 10, \$15.00 per 100

HYBRIDS—All Leading varieties, \$1.50 per 10, \$12.00 per 100

General Catalog and Trade Lists on Application

The NEW ENGLAND NURSERIES, Inc., Bedford, Mass.

Chrysanthemum Mildew

Under extra culture the chrysanthemum is rather free from disease but under poorer conditions is subject to attacks of rust, anthracnose, two leaf-spots, and a powdery mildew probably *Erysiphe Cichoracearum*, by name, which attacks the leaves. In one greenhouse in this vicinity the latter is quite bad, and as others may be troubled with it either now or in the future a short description may not be amiss.

All mildews have two stages; (1) the Conidial, or summer stage when white or colorless "spores" are produced which propagate the disease over summer; and (2), the Perithecial, when the brown or black spores are formed which carry it over winter. The first is by far the less serious, and that is the only one so far as known, occurring on the chrysanthemum under glass. Hence with a little care the trouble, even when quite extensive, can be eradicated easily.

Certain kinds of chrysanthemums seem much more susceptible than others, Col. Appleton being an example. Other varieties as Ivory, Major Bonnafon, and Timothy Eaton, growing alongside of Col. Appleton badly diseased, were not affected. The characteristics of the disease are irregular white, woolly spots on the upper surface of the leaf made up of fine filaments (the mycellum, or growing parts), visible to the naked eye. When very severe, the spots coalesce and the leaf appears as if it were dusted with flour, and when as bad as this may appear on the lower surface. Under the lens or microscope the spots are shown to be colorless, cellular threads, with immense numbers of colorless oval bodies, the conidiophores, corresponding to seeds in higher plants.

Treatment. Plants grown entirely under glass are not liable to contract the disease. It is while they are growing out-doors that they become inoculated with the fungus. If strong, vigorous stock is grown the chances of attack are considerably lessened. For plants already affected sprinkle powdered sulphur (flowers of sulphur) over the diseased parts when they are dry, or if in the greenhouse, evaporate sulphur on the heating pipes.

R. J. Adams.

Peaches Under Glass

Editor of HORTICULTURE.

Dear Sir:—I have a house of peaches. I do not know this variety. How should I force them so as to get them ripe about June, or earlier? Also Cardinal, Alexandra Noblesse, Early Rivers, Thomas Rivers.

Yours truly,

G. F.

If nothing has been done to the trees they should be pruned and cleaned at once and tied up. Take off the top soil about two inches and apply a good top dressing of bone meal and cow manure and cover this over with soil. Give the border a thorough watering three days in succession and be well satisfied that the border is wet through, else when the sap begins to flow the buds will drop off.

Keep the temperature at 42 degrees to 45 degrees at

night, 45 degrees to 50 degrees by day fire heat, and 55 to 60 by sun heat. Care must be taken to start them slowly. Syringe the trees and dampen the floor four times a day until the flowers open. When they are in flower keep the house dry. Shake the trees three or four times a day to set the fruit. When set raise the temperature to 50 degrees at night and correspondingly by day.

Thin fruit when the size of marbles, raise the temperature to 55 degrees to 60 degrees at night and do not increase the night temperature until they have stoned; then it can be increased to 60 degrees to 65 degrees at night. When the fruit begins to ripen give all the air possible day and night and withhold water from the roots and trees, which will give them a higher flavor.

Early Rivers and Cardinal should be ready by the first of June if started at once. The most important things in raising peaches are to start with a low temperature and increase it gradually; have the house and vines clean; never allow the foliage to be wet after sundown; syringe thoroughly on every favorable morning; give abundance of water when fruit has stoned, and withhold water when they begin to ripen and give plenty of air day and night when ripening.

James Wheeler

Asperula

When in flower *Asperula longifolia* is so much like *Gypsophila paniculata* that the writer has known many gardeners to take the former for the latter at first sight. Unfortunately *Asperula longifolia* is not so well known otherwise it would become just as popular. These beautiful hardy plants come into bloom a few weeks earlier than *Gypsophila* which makes them all the more valuable and with the well known *stevias* for winter flowering their most useful flowers can be had for decorative work almost continuously throughout the year. *Asperula longifolia*, *A. hirta*, *A. Areadiensis*, *A. Carpathica* are the only ones of particular merit in this family and ought to be in every hardy plant collection. *A. Areadiensis* is a charming little plant for the rock garden and also for hanging baskets. The flowers are pink and about one inch long with dense woolly foliage and it is the most attractive of the dwarf species, particularly when grown under glass. As a general rule most of the *asperulas* are increased by division. *A. Areadiensis* is such a slow growing species that cuttings are recommended. The *asperulas* mentioned here are all in commerce and can easily be secured. They will grow well in any ordinary garden soil.

David Miller

HORTICULTURE

VOL. VII FEBRUARY 1, 1908 NO. 5

PUBLISHED WEEKLY BY
HORTICULTURE PUBLISHING CO.
 11 Hamilton Place, Boston, Mass.

Telephone, Oxford 292
 WM. J. STEWART, Editor and Manager

SUBSCRIPTION PRICE
 One Year, in advance, \$1.00. To Foreign Countries, 2.00: To Canada, \$1.50
ADVERTISING RATES

Per Inch, 30 inches to page \$1.00.
 Discounts on Contracts for consecutive insertions, as follows:
 One month (4 times) 5 per cent.; three months (13 times) 10 per cent.;
 six months (26 times) 20 per cent.; one year (52 times) 30 per cent.
 Page and half page spaces, special rates on application.

Entered as second-class matter December 8, 1904, at the Post Office at Boston, Mass. under the Act of Congress of March 3, 1879.

CONTENTS

	Page
FRONTISPIECE—Marcellus A. Patten, President-elect American Carnation Society—Portrait.	
CHRYSANTHEMUM MILDEW—R. L. Adams.....	133
PEACHES UNDER GLASS—James Wheeler.....	133
ASPERULA—David Miller	133
NOVELTIES AT WA-NO-KA GREENHOUSES—Illustrated	135
AMERICAN CARNATION SOCIETY	
Opening Session—President's Address.....	136
Secretary's report	137
The Judges' report—Wednesday's Session—Charles McCauley, Portrait.....	138
Thursday's Session—Mrs. A. M. Herr, Portrait—Briefly Told—Marcellus A. Patten.....	139
NEWS OF THE CLUBS AND SOCIETIES	
Society of American Florists.....	140
Massachusetts Horticultural Society—Detroit Florist Club—Louisiana State Horticultural Society—St. Louis Horticultural Society—Lenox Horticultural Society—Twin City Florists' and Gardeners' Club—American Rose Society.....	141
Club and Society Notes.....	142
Park and Forestry Association.....	157
SEED TRADE	142
American Seed Trade Association.....	142
FLOWER MARKET REPORTS	
Boston, Buffalo, Detroit, Indianapolis, Philadelphia, Twin Cities.....	149
OBITUARY	
Wm. H. Ford—J. F. Noll—James Henry Durkee—Simon Held—Christopher H. Shaffer.....	156
MISCELLANEOUS	
Personal	135
Canadian Postage Discussion.....	140
Catalogues Received	143
Incorporated	143
News Notes	146
Fire Record	147
Business Changes	147
New Retail Stores	147
Philadelphia Notes	149
List of Patents.....	157
Greenhouses Building or Contemplated.....	157
Horticulture Society at Wellesley—Illustrated.....	157

times almost the entire value wiped out by bruising and tearing. It is a fact that those establishments known to receive the highest market returns for their product give the greatest of care to the time and method of handling and shipping and that the beautiful condition in which their goods reach the consumer is due in no small degree to this attention. The percentage of profit on cut flower growing at the present time is not so large that one can safely take the chance of carelessness in any of the processes through which his produce must pass to get to the hands of the consumer.

The position taken by President Lemon in his address to the Carnation Society as to what the certificates of the Society do and do not stand for is logical and provides a very safe mooring for the organization on this treacherous question. As advanced in our editorial last week the qualities that go to make a carnation a commercial success, from the cut flower standpoint, are not always demonstrable on the exhibition table and the Society does well to place itself on record to this effect. The propensity to pronounce varieties "worthless," on the one side because they do not size up to the exhibition scale of points or, on the other side, because they prove unprofitable commercially, has been indulged in perhaps too much. Mr. Lemon is right, everlastingly right, in advocating the utmost freedom in the admission of the products of the members of the society to the exhibition table. The judges will quickly decide as to their worth or worthlessness as measured by the exhibition standard and the trade may have a word to say, later on, from a quite different viewpoint.

Another praiseworthy recommendation by President Lemon is the suggestion that the American Carnation Society put into effect some plan for displaying the adaptability of the carnation for various decorative uses. In this particular all our special societies have been conspicuously remiss. The grower should be the first to demand that this feature be given more attention by those who are entrusted with the preparing of prize schedules or the management of exhibitions. It is well to display to the public the beautiful products of the skill of hybridizer and grower but the welfare of these is inseparably woven with the disposal of these products after it has left their hands and the mission of the Society in advancing the interests of its members and the art to which they are wedded is only half-accomplished until the public have been awakened to the possibilities in the decorative use of such material. There are other points upon which Mr. Lemon speaks with that wisdom which comes only from experience and observation. Altogether we regard it as one of the best papers ever presented before the American Carnation Society and well-worthy of a careful perusal by those who were not present to listen to it.

It is hard to comprehend the flower grower who, having turned out a credit-able product, handles it as he would any old rubbish. While this abuse is less frequent than it was a few years ago yet one does not have to look far in the wholesale markets to find good roses, lilies and similar things giving evidence of care-lessness, rough handling and packing, sufficient to reduce their selling value one-half or even much more—some-

Costly carelessness

NOVELTIES AT WA-NO-KA GREEN-HOUSES.

Our illustrations on this page show three very handsome houses of carnations, all novelties, two to be introduced in 1908-9 and one in the following year. The establishment at Barneveld, N. Y., known as the Wa-No-Ka greenhouses, was originally that of H. H. Nicholson & Co., and the firm is now composed of H. H. Nicholson and A. O. Grasl, the latter gentleman being an expert grower and successful hybridizer of carnations. The following interesting descriptions of the three varieties shown in the illustrations are as given by the originators:

"Apple Blossom," a gorgeous, full, white, with a delicate pink blending in the centre of the flower. Flowers borne on long, stiff stems, very fragrant, and in great profusion through the season. Calyx does not split, and the flowers have excellent keeping quality. Best grown in night temperature of 48 and 50 degrees. This variety is distinctly of the "Bread and Butter" sort, because of its prodigious blooming quality. Flowers average three inches through the season. To be disseminated during the season of 1908-'09.

"Wanoka," named from the Indian word, "Wah-No-Kah," meaning "Just one of its kind." A superb, well formed and fragrant Crimson, of remarkable production, and borne on extremely long and heavy stems. It succeeds best in night temperature of 50 degrees. The calyx never splits, and the flowers average three inches and are first-class shippers. To be disseminated during the season of 1908-'09.

"Climax" is a shade or two deeper than Enchantress, a color long desired by the growers and the public. The color is permanent and does not fade. Flowers do not have the irregular form of Enchantress, are very fragrant and excellent shippers. They average the season through, three inches, and from December to April are 3 1-2 inches and over. The calyx is remarkably strong and seldom splits. Best grown in night temperature of 48 and 50 degrees. Will be disseminated during the season of 1909-'10.

PERSONAL.

John Mitchell, Cabot street, Beverly, Mass., is seriously ill at his home.

G. B. Wiegand of Indianapolis, Ind., starts on February 1 on a two months' trip to California.

William Brown, florist, Mansfield, Mass., has recovered from his recent attack of pneumonia.

E. T. Mische of Madison, Wis., has accepted a position as superintendent of parks in Portland, Ore., and will assume the office in March.

R. S. Williams, of the N. Y. Botanical Gardens, sailed on January 25 for Panama in search of orchids and plant novelties. He expects to return in May.



BENCH OF "APPLE BLOSSOM" IN OCTOBER.

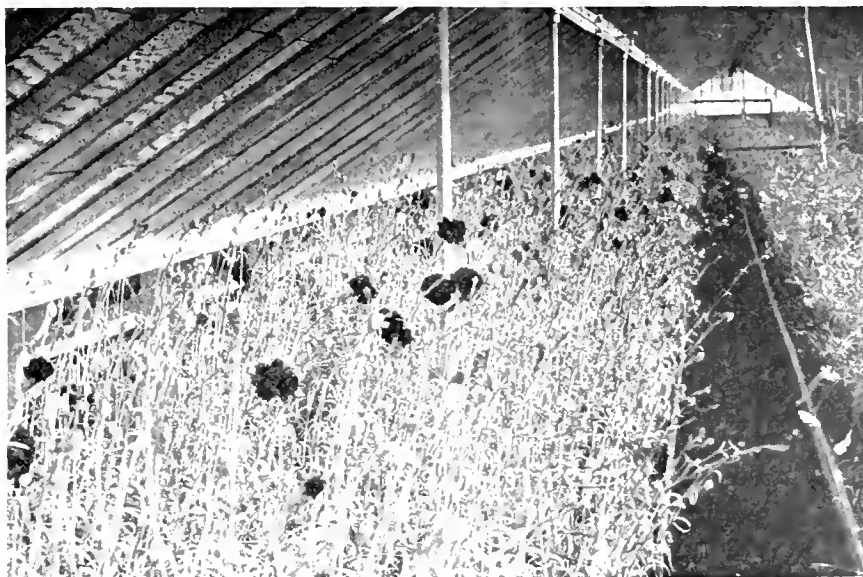

BENCH OF "WANOKA" IN SEPTEMBER



BENCH OF "CLIMAX" IN OCTOBER

AMERICAN CARNATION SOCIETY.

A Successful Convention, Interesting Sessions and a Superb Exhibition at National Rifles Armory, Washington, D. C.

Tuesday, January 28th, opened with bright skies and balmy weather, and Washington's welcome to the carnationists of America was thus gracefully accentuated by Nature's serenity, following so closely upon the wild blizzard of a few days before and so marked in contrast with the weather conditions which have so often dismayed the votaries of the divine flower. The forenoon was spent in fraternal greetings between friends who meet thus pleasantly once or twice a year and the important work of staging and classifying the exhibits. A brief meeting was held in the ante-room for the purpose of selecting judges, and Messrs. M. A. Patten, Peter Fisher and S. J. Reuter were chosen for this important duty. At 1 p. m. the hall was cleared and the judges took possession. It required most of the afternoon for their deliberations. Their report, presented and accepted at the evening session of the Society, will be found in its proper place in the pages that follow.

THE OPENING SESSION.

The opening session of the American Carnation Society was called to order promptly at 7.30 P. M., on Tuesday, January 28, by Mr. Peter Bisset, president of the Florists' Club of Washington and vice-president of the American Carnation Society. After a few words of welcome in which he expressed his pleasure at the coming and congratulations on the work of the Society and felicitation upon the grand exhibition he introduced Commissioner McFarland, of the District of Columbia, who extended an eloquent welcome to the visitors, mentioning especially those from Canada, hoping that they would feel just as much at home as the United States members of the Carnation Society had been made to feel when they visited Toronto one year ago. He spoke enthusiastically of the work and expenditures so liberally given for the development and beautification of the National Capital. The carnation society, he asserted, stands for one of the most beautiful of flowers, and its visit to Washington on the eve of the birthday of President Wm. McKinley, who had so loved the carnation, was most opportune and fitting.

Frank R. Pierson, of Tarrytown, N. Y., voiced the sentiments of the Society in response to the words of welcome, not only on behalf of the United States members but of those across the border and reverted pleasantly to the cordial reception accorded last year by the carnation brethren. He told of the more than ordinary interest felt in the National Capital by the members of the Carnation Society,

which was an off-shoot from the great Society of American Florists, which was the proud possessor of that unique document—a National Charter—granted to them in Washington and bearing the signature of William McKinley. He hoped to see McKinley Day and the custom of wearing a carnation on that day become a national observance and a significant feature in American history.

J. H. Dunlop, of Toronto, followed Mr. Pierson, felicitously expressing the reciprocal good feeling of his countrymen. He said that there was no "dividing line" in the sympathies and aims of the florists, who go always hand in hand regardless of political affiliations, with brotherly love and a common purpose.

Mr. Bisset then introduced the president of the American Carnation Society, Fred H. Lemon, who was received with enthusiastic applause and then proceeded to read his opening address as follows:

ADDRESS OF THE PRESIDENT.

Gentlemen, Fellow Members of the American Carnation Society:

It has been the custom for a number of years for the President to share in extending a welcome to the members of the American Carnation Society. Today the seventeenth President has the privilege and honor of sharing in the expression of thanks and appreciation for the hospitable reception and cordial welcome extended by the convention city.

It must be remembered at this time that the real work of preparation for this convention has been done by our most worthy vice-president, Mr. Peter Bisset, and his able assistants in Washington. Allow me to express at this time my personal appreciation of the unflinching courtesy, and the untiring zeal and activity of the vice-president, which, together with the efficient services of the secretary, made possible this most successful exhibition and convention.

Reference has frequently been made during the last few years to the subject of the society's certificate; it is a pleasure to refer to the eminently sensible and correct settlement of the controversy at the convention in Toronto last year. The remarks on the subject, by our honored member, Mr. W. N. Rudd, contain the best exposition of the aims and province of the American Carnation Society to be found in all the society's literature. It is indeed true, as stated in these remarks, that "the certificate is nothing except an opinion of the quality of the flower shown at the exhibition. The commercial value of carnations must

be shown in other ways; and it is beyond the ability of this society, beyond its province, to attempt to say whether or not a certain carnation shall prove a profitable investment to the buyer." I wish at this time to most emphatically endorse this position in relation to new varieties and to urge the society to encourage in every way possible the production of new kinds and especially the exhibiting of new things at our annual shows.

There has been a decided inclination, during the past few years, to belittle the value of the showing made by a carnation at the American Carnation Society Exhibition. Opinions of this kind have been expressed by many prominent members and have even crept into a number of addresses by our past Presidents. I desire to especially emphasize my opinion that any variety which can win the American Carnation Society medal, or obtain first place in one of our open-to-all classes, must possess many points of exceptional merit. The fact of its winning is prima facie evidence, and is incontrovertible, for the judgment is the expressed belief of at least two, and more often three, of the leading experts of the country, that such variety has produced blooms superior to any others of its class. The trade at large, and particularly members of this society, should accept this at its full value; that is to say, should recognize such action as coming from the highest tribunal and as being the best opinion obtainable in the United States on the subject. The idea that the American Carnation Society does thereby guarantee such variety to be a profitable one to grow commercially is a false position and should be avoided in the future. The society as a body can possess only the prescience of its integral parts, its individual members, and what man among us can unflinchingly predict a carnation's future even after studying the variety from all vantage points. The production of fine blooms is a prime requisite and with this alone should the society concern itself, leaving prophecies as to the probable future of a variety to individual judgment.

Any practical grower of carnations should consider the grant of a certificate or medal by the American Carnation Society as the very highest recommendation possible and amply sufficient proof of merit to justify a thorough test and earnest effort to grow the variety as well as it has been grown by the raiser.

However, there is one point in this connection which does come within the province of this society, and that is, the proper recognition of merit

which has been abundantly proven seven years ago, at Indianapolis, when the fatal illness of the President, Wm. J. Bertermann, placed me in the position of acting chairman, I suggested that the society ought to take some action commending the raiser of any carnation which has proved itself the premier variety of its class for a number of successive years. No attention was given the suggestion at that time, but my opinion has not changed on the subject. I believe that when any variety wins first prize in any class A (open to all) section, for three successive years, the raiser of such variety should be granted the society's gold medal fittingly engraved as an award of sterling merit. It is at least a subject worthy of discussion. There ought also to be a sweepstakes prize covering class A (open to all) sections.

To refer again to the certificate classes, I believe that the entrance fee in both preliminary and final certificate classes, should be omitted except when such certificate is granted, and that the only restriction placed on exhibiting in these classes should be membership in the society. This should be done for the purpose of increasing the number of exhibits in these classes. The judges may be depended on to properly sift such candidates.

Reference has been made annually, since the inception of this society, to the proposed exhibition of carnations in pots. Ex-President Rackham spoke of the matter in his address at Detroit. Mr. John Birnie made a strong plea for such varieties in his able paper at Toronto last year. Now to accomplish anything in this line will require a radical step by the society and it may as well be taken at once. Offer a good substantial prize for the best collection of plants in bloom in pots. To do this, reduce the breadth and scope of Class B, which, as it now stands, tends toward monotony in the exhibition.

Also, if it were possible to so divide the money devoted to premiums to admit of it, a certain amount ought to be devoted each year to exhibitions showing the adaptability of the carnation to reception and wedding decorations. Competitive contests among local retail men are not practicable, but some prominent retail man might be selected to prepare some such exhibit each year, as this would interest the public greatly and add to the beauty of the exhibition.

The very valuable papers from foreign carnation growers last year, together with the reports appearing in our trade papers from time to time, indicate the rapid strides being taken by our co-workers in England in the development of the Everblooming Carnation. Such reports should stimulate the activity in America for we should retain our supremacy in this line. Taking into consideration the formidable opposition in the securing of new varieties of carnations which the English breeders have now presented, would it not be a good thing to make some arrangement whereby new English sorts could be sent here for tests as to their adaptability to American conditions and markets? Probably some exchange of novelties could be made between growers in the United States and those in England

for this purpose. A great deal of interest is now being taken in American varieties over in England, and the same thing is likely to happen with English varieties in the United States; hence it would be well for the American Carnation Society to take the first steps aiming towards co-operation.

In the matter of the registration of new varieties, the opinion has been expressed by interested members that the society ought to omit all superfluous verbiage as to whether the new variety is better than others of its kind, and give simply the name, the parentage, the date when the cross was made, and the color. A uniform registration blank should be adopted and this should avoid any appearance of indorsing the good qualities of a new kind.

At the Chicago convention in 1907 no action was passed authorizing the offering of American Carnation Society certificates at the fall exhibition in our leading cities, and the appointment of judges for such exhibits. There was a committee appointed with power to act, but the plan never was carried out. This should be taken up and some definite action taken. The S. A. F. and O. H. has invited the co-operation of our society in the National Flower Show to be held in Chicago in November of this year, and we should offer our certificate and medals at that great exhibition.

It is with great pleasure that I look forward to the joint meetings with the American Breeders' Association. I hope and believe that much of benefit to the practical grower may result from the joint discussion on carnation breeding. If there is anything tangible as regards Mendel's law in relation to the breeding of carnations it should be brought out at this time.

The business sessions of the convention in Toronto were the best attended of any convention in a number of years. I am counting on the members to surpass that record in Washington.

In closing I desire again to join with the visiting members of this society in appreciation of the efforts of the Washington florists which have made possible a successful convention.

It is a high honor to be chosen President of the best, most business-like and most effective florists' organization in the United States, and I thank you most heartily for that honor.

Secretary A. M. Herr then presented his annual report, as follows:

SECRETARY'S REPORT.

Mr. President and members of the American Carnation Society:

Gentlemen,—Your Secretary reports having issued the regular printed matter of the Society during the past year. Our Annual Report was more complete than usual, thanks to our stenographer and the fact that being from my own city it could be worked out to better advantage than could possibly be done by correspondence.

The premium list and dates for the meeting were discussed and adopted at the meeting of the Board of Directors held in Philadelphia last August, quite a few changes being made in the premium list, and a three-day session agreed upon as an experiment, all of which was duly announced through the trade papers.

It has since developed that a portion of intending exhibitors are not able to get their flowers through in time for staging for 1 P. M. Tuesday. I would suggest that a portion of our meeting be set aside for the purpose of adopting a premium list, a set of rules governing the exhibition, and the best date for the opening of the show in 1909. With exhibitors, judges and the Board of Directors all present, mistakes and friction could be avoided. The exhibitor being the first consideration in our shows should have first consideration in our premium list.

In the opinion of your Secretary the matter of advertising in our premium list should be dispensed with. The members do not patronize it to any extent, even after personal solicitation and it is hard to get outsiders to look upon it as a good business proposition. For the one issued this year a circular letter was sent to all members of this Society, followed up by a personal letter to the possible advertisers (in some cases two and three) and in addition to this, personal letters were sent to about four hundred other advertisers with the results shown before you. The getting up of the premium list, aside from the solicitation, is almost as much work as getting out the annual report, and after deducting the extra cost of printing there is such a small margin of profit that it is hardly just to your secretary to pile all this work upon him.

A pet scheme of my own was tried this year and an invitation sent to every florist within a radius of one hundred miles from the meeting place to join the Society. The responses were two new members and several inquiries, a result that teaches its own lesson.

In addition to all of the foregoing there have been about seven hundred pieces of mail mostly personal letters in response to inquiries, and the regular correspondence between this office, your President and the Board of Directors.

Your Secretary requests that unless you have selected a successor for the coming year, he be continued in office for one year longer in order to use up stationery and other matter that would have to be changed and lost if a new one were elected, and that he then be released. The work of this Society is increasing in a ratio of about three to one as compared to membership; it is a work that ought to be done and for which the Society is not in a position to pay a competent salary, so that in making your selection it will be the part of wisdom to select a secretary who has leisure time to devote to this work and one who employs clerical help, to whom can be given the routine of the work. Your present incumbent having served the Society for thirteen years feels that with another year's service to break the hoodoo, he has borne his share of the work and that some one more competent and better able to give the time and labor required should take it up and carry it on to completion.

The report of Treasurer F. Dorner, Jr., was next presented.

Secretary Herr, on behalf of the Nomenclature Committee reported that the registration record for the past year was four seedlings and

three sports. They advised that the Society demand registration of all new varieties presented for the Society's consideration and that all sports be given distinctive names. The above reports were all duly accepted. A committee consisting of Messrs. Rudd, Baur and Fotheringham was appointed to consider and recommend such action as they deemed wise in accordance with recommendations in the President's address. Invitations to hold the next meeting in Indianapolis, Ind., and Pittsburg, Pa., were presented. The invitation to Pittsburg came from the Florists' and Gardeners' Club of that city, and told of the overwhelming wave of good feeling and hospitality that awaited the acceptance of the invitation. The State Florists' Association of Indiana on behalf of Indianapolis offered a Hoosier welcome and royal good time. Nomination of officers being next in order, the following names were presented: President, Marcellus A. Patten, of Tewksbury, Mass.; vice-president, Wm. Falconer, Pittsburg, and A. F. J. Baur, Indianapolis; secretary, A. M. Herr; treasurer, F. Dorner, Jr. Peter Fisher was chosen judge to succeed Wm. Scott, resigned, and Wm. Nicholson was selected to succeed himself. J. S. Wilson was chosen to succeed himself as director.

THE JUDGES' REPORT.

The judges then presented their report on the exhibition and same was duly accepted.

List of Awards.

The vases of 100 blooms each in Class A made a fine show in themselves. In white Cottage Gardens Co. took first with Alma Ward, and F. R. Pierson Co. second with White Enchantress. Light pink—Chicago Carnation Co., with Enchantress. Dark pink—E. G. Hill Co., Afterglow; second, Cottage Gardens Co., Mrs. Thomas Harvey. Winsor shade of pink—Cottage Gardens Co., with Mrs. C. W. Ward; second, Chicago Carnation Co. Winsor. Scarlet—Cottage Gardens Co., Beacon; second, John Reimels, seedling No. 32. Crimson—Cottage Gardens Co., Creole Beauty; second, J. D. Cockerolt, Harvard. White variegated—John Reimels, Variegated Lawson. Any other color—H. Weber & Sons Co., Torcadour; second, J. E. Haines, Imperial.

In Class B, vases of 50 blooms each of specially named varieties, the awards were as follows: Lady Bountiful—Stafford Flower Farms. White Perfection—F. R. Pierson Co.; second, S. J. Gouldard. Any other white—F. R. Pierson Co., White Enchantress; second, Stafford Flower Farms, Lieut. Peary. Enchantress, Chicago Carnation Co.; second, Stafford Flower Farms. Any other this shade—F. R. Pierson Co., Melody; second, H. Eichholz, Mrs. M. T. Onwaka. Winsor—Chicago Carnation Co.; second, Cottage Gardens Co., Pink Enchantress—F. R. Pierson Co.; second, H. D. Rohrer. Any other this shade—Chicago Carnation Co., Welcome; second, H. Weber & Sons Co., Genevieve Lord. Lawson—Potter, the Florist, Aristocrat, Chicago Carnation Co.; second, R. Witterstaetter. Pink Imperial—John E. Haines, Robert Craig—H. D. Rohrer. Red Chief—F. R. Pierson Co.,

Victory—F. R. Pierson Co.; second, S. J. Gouldard. Beacon—Cottage Gardens Co.; second, F. R. Pierson Co. Any other scarlet—Chicago Carnation Co., Andrew Carnegie; second, John E. Haines, J. E. Haines. Mrs. M. A. Patten—Cottage Gardens Co. Imperial—John E. Haines. Any other white variegated—F. R. Pierson Co., Variegated Lawson. Only one award was given in the crimson class—Cottage Gardens Co. for Octoroon.

The special premiums were well competed for and the centre of much interest. The Gold Medal for best vase of 100 blooms, any variety, any color, was won by Cottage Gardens Co. with Alma Ward. The Silver Medal went to R. Witterstaetter for Afterglow and the Bronze to Cottage Gardens Co. for Mrs. C. W. Ward. The S. A. F. medals for best vase of 50 blooms of carnations not yet dis-

Carnation Co. for White Perfection. C. A. Goldsmith's cup for 50 red, to Cottage Gardens' Co. for Beacon Harty's cup for largest display was won by the Chicago Carnation Co. The Vonderheide cup for 100 blooms of variety disseminated 1908 was awarded to R. Witterstaetter for Afterglow. The Berry & Whitmore cup for 50 light pink was not awarded. A preliminary certificate was given to M. A. Patten for his seedling, 46-205. Certificates of Merit were awarded to Joseph Heacock for light pink seedling No. 100, 86 points; to Wa-No-Ka Greenhouses for Wa-No-Ka, 86 points; and to H. W. Field for President Seelye, 89 points.

Besides the carnations the following exhibits were mentioned in the report of the prizes: "Queen Beatrice rose by F. H. Kramer, very fine blooms tastefully arranged. Two vases of rose Mrs. Jardine, very fine, fragrance remarkable, by Robert Scott & Son, Rhea Reid, a grand vase of roses from E. G. Hill Co. Nephrolepis superbissima, a fine new fern, F. R. Pierson Co. Three vases of Violet Boston, by Wm. Sim."

WEDNESDAY'S SESSION.

The session on Wednesday morning opened at 10.15 A. M., and Dr. B. F. Galloway was the first speaker, his subject being the work being done by the Department of Agriculture on the questions connected with the breeding and commercial cultivation of the carnation. Crossing selection, breeding, feeding, soils, insects and diseases were the various features touched upon. We expect to present Dr. Galloway's paper in full in a later issue. On the conclusion of his paper the members plied him with questions on many points of practical interest. In reference to the use of manures he said that cow manure is preferable to any other in carnation growing, but in violet culture there is little difference between this and other stable manures. He emphasized the comparative uselessness of bone fertilizer and referred to its frequent injurious effects. As to hardwood ashes he said that this was fairly beneficial to sweeten the soil and supply potash when same is needed but that there is danger in its over-use. Sandy soil is apt to give shorter stem growth but by wise use of organic manures this can be overcome. Bone manure may be more beneficially used in sandy than in a heavy soil and sheep manure used in a liquid form has proved valuable. But in short, there is more in the brain matter of the man who handles the soil than in the soil itself and good sense, application and general intelligence are the strongest factors in carnation culture as in all other things. A cordial vote of thanks was tendered to Dr. Galloway. Selection of place of meeting for 1909 was then taken up, Indianapolis and Pittsburg being in nomination. Coaxing and otherwise diplomatic speeches were made by a number of advocates of the two cities, and the proceedings were characterized with remarkable good nature. The ballots having been cast and counted, the tellers announced a tie vote, 83 for each city. Then came some fun, but it was cut short in a most generous motion by C. S. Crall of Monongahela City,



CHARLES MCCAULEY
Secretary Florists' Club of Washington.

Never has an exhibition been handled with such system and absence of disorder. The selection of Chas. McCauley as superintendent proved to have been a most excellent inspiration for he worked earnestly and to good purpose and everybody was pleased. The arrangement of the tables was excellent.

seminated were won by the same varieties—Silver Medal to Cottage Gardens Co.'s Alma Ward and Bronze Medal to Witterstaetter's Afterglow.

The H. F. Michel vase for 100 blooms, grown by private gardeners, was awarded to Wm. Kleinheinz. Peter Bisset's prize was won by the same exhibitor. Peter Fisher's prizes for 50 Beacon were won by Cottage Gardens Co., F. R. Pierson Co., Stafford Flower Farms respectively. Geo. H. Cooke's prize for 25 pink was awarded to Joseph Heacock for seedling No. 100. Geo. C. Shaffer's prize was won by Henry Eichholz. S. C. Briggs' prize for best vase of 50 white went to Cottage Gardens' Co., for Lieut. Peary. John Robinson's prize for 25 Winsor was won by Cottage Gardens' Co. Z. D. Blackstone's prize for 50 white was awarded to Chicago

representing the Pittsburg advocates, that a unanimous vote be cast in favor of Indianapolis, and thus the parliamentarians who had been sharpening their broadswords for a battle royal were quietly sidestepped and great jubilation followed. During the voting a discussion on the alleged imperfections of the premium list was under way, and the matter was finally turned over to the executive committee, with request to report before close of convention. An announcement by the president that President Roosevelt would receive the members of the American Carnation Society and the Breeders' Association at 2.30 on Thursday afternoon was received with applause.

On Wednesday afternoon the Carnation Society united with the American Breeders' Association under the auspices of the latter organization, and the feature of the session was an address by Dr. Alexander Graham Bell on Heredity. Those members who were present enjoyed a rare treat. The program was as follows:

Original Work Among Native Roses, by W. Van Fleet, Little Silver, N. J.
Some Observations in Plant Improvement, by A. M. Soule, Athens, Ga.

Report of Committee on Breeding Roses, by Peter Bisset, Washington, D. C.

Development of the Immune or Resistant Character in Plants, by H. L. Bolley, Fargo, N. Dak.

Report of Committee on Breeding Carnations, by C. W. Ward, Queens, N. Y.

The evening session opened with a paper by S. S. Skidelsky on "What the grower should expect from the introduction of a new seedling."

Mr. W. N. Rudd followed with a brief statement of the question from the standpoint of the introducer. Fair dealing was his text and he proved his case. F. R. Pierson followed with a lucid statement of the position of the introducer who he claimed had not been fully appreciated. Irving Gingrich's paper on cultural methods for carnations was next read by John H. Dunlop.

The question of the National Flower Show was then broached by Mr. Rudd, who asked that the Carnation Society stand sponsor for the carnation and offer some medals for competition at that event next November. W. F. Kasting followed in approval saying that the Carnation Society should be interested as well as any other and that it was not a question of money but of co-operation. Three medals were appropriated by unanimous vote and it was decided that the regular judges of the Society should officiate on behalf of the Carnation Society in making the affidavits.

THURSDAY'S SESSION.

Thursday morning's session opened with election of officers. Mr. Falconet's name having been withdrawn as candidate for vice-president, unanimous ballots were cast for all the officers and the chair announced the following as elected for ensuing year: President, M. A. Patten; vice-president, A. F. J. Baur; secretary, A. M.

Herr; treasurer, F. Dornier, Jr.; director, J. S. Wilson; judges, Peter Fisher and Wm. Nicholson. Vigorous and interesting discussions ensued on the recommendations in the President's address and other topics. It was voted that in future no charge be made to members for certificate entry or registration of new varieties, also that the directors may recommend to the society the award of a special gold medal of merit to the originator of any variety which has maintained commercial superiority for a number of years. It was also voted that hereafter no unregistered variety be allowed in competition at the exhibitions.

M. A. Patten, W. P. Craig and A. J. Baur were appointed committee on final resolutions.

At two o'clock the members assembled at the hall and proceeded to the White House, where they were cordially received by President Roosevelt. On returning to the hall, business was



MRS. A. M. HERR

We were sorry that in the gallery of Carnation Society notables last week we were not able to include the portrait of Mrs. Herr who, with all due respect to her busy husband, has been one of the indispensable attaches of the Society, ably aiding the secretary in the clerical work and endearing herself to every attendant at the convention by her ever-ready courtesy and tact.

resumed and paper by R. Witterstaetter, Prof. J. B. Norton and C. W. Ward were read, the latter illustrated by many beautiful stereopticon views.

The banquet on Thursday evening at Rauscher's was a magnificent affair. The floral decorations were superb, and the speeches brilliant. A full account will be given in next week's issue.

PRESIDENT-ELECT PATTEN.

The American Carnation Society conferred its highest gift on a man eminently worthy of the distinction when it selected for its standard bearer for the coming year, by a unanimous vote, Marcellus A. Patten of Tewksbury, Mass. Fitted by nature with the intellectual gifts and manly attributes, and by experience with the

skill and practical knowledge which go to make up the ideal chief officer of such an institution, Mr. Patten brings to the office that dignity, character and fitness which promise the highest efficiency in the coming year. Mr. Patten is a native of Lowell, Mass., having been born in that city in 1849. His first experience in floriculture was with W. C. Strong & Co., Brighton, Mass., and later with Weiland Bros., Cambridge, after which he went into the florist business on his own account in Lowell. Subsequently he disposed of his Lowell interests and built a range of houses at Tewksbury, where his abilities as a carnation grower soon commanded wide attention at the exhibitions of the Massachusetts Horticultural Society, the American Carnation Society and the Gardeners' and Florists' Club of Boston, with all of which organizations he has long been identified, his flowers have won high honors and he is accounted one of the most skilful carnation growers for the Boston market.

BRIEFLY TOLD.

W. R. Smith was missed from the convention hall but he received many calls at his home in the Botanic Garden where he was confined by a slight attack of grippe.

F. H. Lemon proved to be an ideal presiding officer. Cool, courteous, well-balanced, firm when necessary and never at a loss to define his position, he held the reins like a professional.

The three day scheme seems to have demonstrated its desirability, affording abundant time for deliberation, gratulation and observation and no doubt will be the rule for carnation conventions henceforth.

Much comment was heard concerning the small number of Boston entries in the exhibition. The explanation is that the express company would not agree to deliver Boston shipments in time for the judging at 1 P. M., Tuesday.

Secretary Herr's announcement of his intention to withdraw from the secretaryship next year makes a new problem for the Carnation Society. Secretary Herr has been a faithful, hard working official and his place cannot easily be filled.

Only once before in its history, on the occasion of its second visit to Boston, has the Carnation Society been favored with fair weather and moderate temperature. Washington did nobly and the weather man has our sincere thanks.

According to time-honored custom the Boston delegation had its annual symposium in the innermost cave of the palace on Tuesday-Wednesday midnight and subsequent hours. No casualties except to the baked beans, codfish and other delicacies dear to the New England gourmet.

Indianapolis was congratulated on its gracious and graceful acceptance of defeat by Washington last year but Pittsburg has beat the record with its unanimous proposition in the face

of a tie vote to make the selection unanimous for its opponent. It was a master-stroke.

Winona, Dorner's lovely pink variety, showed up beautifully on the second day. It is a superlatively good keeper. Wa-No-Ka made a splendid impression as a crimson. It also displayed fine keeping qualities. President Seelye, the Northampton sensation, was also pointed out as a splendid acquisition.

Among the more sensational features of the exhibition were the exhibits of W. N. Rudd, 51 hours on the road from Chicago, arriving on Wednesday morning in remarkably fine condition. The varieties were two seedlings, 1605-A, white, and 28103-A, rose pink, both dangerously near the four-inch class and evidently in it for future honors. Another good thing is Mr. Heacock's No. 100, much resembling Rose Pink Enchantress, but with a better built flower than that popular variety; a seedling of Enchantress crossed with Lawson.

CANADIAN POSTAGE DISCUSSION.

Consul James H. Worman, of Three Rivers, makes the following report on a movement in Canada to secure the former postage rates on periodicals to and from this country:

Newspaper publishers in the Province of Quebec have petitioned the Dominion post-office department to restore the old rates on newspapers and magazines between the United States and Canada, a six months' trial of the new rates having proved the injurious effects to the Canadian press and people.

The Montreal French chamber of commerce has also urged the repeal of the new regulations, and its committee appointed to look into the matter has reported. It was held that any restriction placed on the circulation of Canadian papers in the United States and in other foreign countries would prevent this country from being known and appreciated; that it would tend to neutralize the patriotic efforts of the Canadian press, and that it would unfavorably affect immigration to Canada as well as the repatriation of French Canadians. Persuaded that in the interests of colonization and commercial prosperity the country needed far more advertising than was given to it in the press, the chamber of commerce had requested the federal government to further such advertising by the creation of a commercial museum and the distribution of explanatory guides on the resources of Canada. The committee states also that the circulation in this country of American magazines is of great advantage to trade and industry, both from a scientific and a news standpoint.

Inclosed please find check for \$2.00 for two years' subscription to HORTICULTURE, which I value very highly and look forward to with pleasure each week. Wishing you the best of success and a happy and prosperous new year.

FRED C. GREEN.

Warwick, R. I., Dec. 30, 1907.

SOCIETY OF AMERICAN FLORISTS AND ORNAMENTAL HORTICULTURISTS.

National Flower Show Premium List.

The premium list for the National Flower Show is now in press and will be ready for mailing on February 15th. Many changes have been made in the list originally published in the trade papers and the same has been largely increased.

It is believed that the complete list carries the largest amount in premiums, medals, cups and trophies ever offered at any floricultural exhibition at any time. Suggestions for premiums have been made and revision of all or parts of the list by about one hundred individuals and firms and it is hoped that in the form in which it will appear on the above date all classes of exhibitors will be found to be amply provided for.

It should be noted that the suggestions made to the committee if all had been carried out, would have required over five times the large sum of money which was available. This condition, of course, made it necessary to strike out many desirable suggestions. All suggestions, however, were given equal consideration on their merit without regard to the names of the persons making them.

Copies of the list may be obtained on application to Mr. J. H. Burdett, secretary, 1111 First National Bank Building, Chicago.

The thanks of the committee are tendered to those public spirited and generous firms and individuals who have responded so nobly.

The many others who intend making similar offers are urgently requested to "HURRY UP" so that all may be included in the preliminary list now in press, as otherwise proper publicity and a good competition cannot be secured.

W. N. RUDD,
Chairman Premium Committee,
Morgan Park, Ill.

The following is the list of special premiums offered up to date.

American Florist Co., 324 Dearborn Street, Chicago—Cup, value \$25; class not yet specified.

B. K. & B. Floral Co., Richmond, Ind.—For 50 blooms Sarah Hill carnation, \$8 first; \$5 second; 50 blooms Lawson-Enchantress carnations, \$8 first; \$5 second.

Chicago Carnation Co., Joliet, Ill.—50 blooms Andrew Carnegie carnation, \$12 first; \$8 second; \$5 third.

Chicago Florists' Club, Chicago—Trophy value \$50; class not yet specified.

Chrysanthemum Society of America—Cup for 10 blooms, one variety chrysanthemum, any color.

W. W. Coles, Kokomo, Ind.—Cash, \$10; class not yet specified.

Win. P. Craig, 1205 Filbert Street, Philadelphia, Pa.—Cup, value \$30, for 50 blooms Mrs. Jardine rose; grown by grower with not more than 50,000 feet of glass.

The Albert Dickinson Co., West Taylor Street and the river, Chicago—Cash \$25; class not yet specified.

A. Dietsch Co., 615-621 Sheffield Avenue, Chicago—Cash \$10; class not yet specified.

Henry A. Dreer, 714 Chestnut Street, Philadelphia, Pa.—Cash \$200; classes not yet specified.

W. H. Elliott, Oak Square, Brighton, Mass.—Cup, value \$50; class not yet specified.

Alexander J. Guttman, 43 W. Twenty-Eighth Street, New York—For 50 blooms Victory carnation, \$12 first; \$8 second; \$5 third.

E. V. Hallock, Queens, N. Y.—For 12 blooms each of 12 varieties best hardy garden roses, or two plants in pots of each

of the 12 varieties. Plants to stand zero to 10 degrees below. Exhibitor to select his own varieties; quality of blooms or plants, 80 points; desirability for growth under conditions named, 20 points, \$50 first; \$35 second; \$15 third.

The E. G. Hill Co., Richmond, Ind.—Trophy; class not yet specified.

Horticultural Society of Chicago—Medals, value \$500; classes not yet specified.

Win. F. Kasting Co., 383-387 Elliott Street, Buffalo, N. Y.—Cash \$50; class not yet specified.

The King Construction Co., North Tonawanda, N. Y., and Toronto, Ont.—Cash \$25; for 100 blooms carnations, any variety in commerce. Competition limited to those owning or operating not over 25,000 feet of glass.

Lord & Burham Co., Irvington on Hudson, N. Y.—Gold medal for best general collection of orchids grown and exhibited by a private gardener.

Henry F. Michell Co., Philadelphia, Pa.—Cash \$10; class not yet specified.

John C. Moninger Co., Hawthorne, Blackhawk and Smith Avenues, Chicago—Three cups; classes not yet specified.

F. R. Pierson Co., Tarrytown on Hudson, N. Y.—For 50 blooms Winsor carnation; \$12 first; \$8 second; \$5 third. 50 blooms White Enchantress carnation; \$12 first; \$8 second; \$5 third. Cup, value \$25, for best specimen Nephrolepis Person elegantissima grown in not over 12-inch pot or pan.

Poehlmann Bros. Co., Morton Grove, Ill.—Cash or cup, value \$25, for 100 blooms Mrs. Potter Palmer rose.

Quaker City Machine Co., Richmond, Ind.—Cash \$25; class not yet specified.

Peter Reinberg, 51 Wabash Avenue, Chicago—Cup, value \$25; class not yet specified.

W. N. Rudd, Morgan Park, Ill., and Jensen & Dekema, 674 W. Foster Avenue, Chicago—For 50 blooms Carnation Defiance; \$12 first; \$8 second; \$5 third. Donors barred from competition.

Robert Scott & Sons, Sharon Hill, Pa.—Cup, value \$50, for 100 blooms Mrs. Jardine rose.

S. S. Skidelsky, 1741 North Eighteenth Street, Philadelphia, Pa.—Cash, \$25; class not yet specified.

Elmer D. Smith & Co., Adrian, Mich.—Cash, \$50, for best 25 blooms chrysanthemums of American origin, five or more varieties shown in one vase, not less than 36-inch stem. To be judged from commercial standpoint. Undisseminated varieties admissible.

Society of American Florists—Ten silver gilt medals; 25 silver medals; 25 bronze medals; classes not yet specified.

The Stairs & Harrison Co., Painesville, O.—Trophy, \$25; class not yet specified.

Charles H. Totty, Madison, N. J.—Cup, value \$50, for 6 vases of chrysanthemums, single varieties, one color to a vase; 20 prayers in each vase.

Vaughan's Seed Store, Chicago and New York—Not specified.

The Cottage Gardens Co., Queens, N. Y.—Cup, value \$100, for best vase 100 carnations, variety either not yet in commerce or not introduced to commerce prior to 1906.

Welch Bros., 226 Devonshire Street, Boston, Mass.—Cash, \$25; class not yet specified.

J. P. Wilcox, 521 Broadway, Council Bluffs, Ia.—Cup, value \$35; class not yet specified.

R. Witterstaetter, Cincinnati, O.—For 50 blooms Afterglow carnations; \$12 first; \$8 second; \$5 third.

Eilwanger & Barry, Rochester—Silver Cup for best collection of Hybrid Perpetual Roses.

Frank H. Treandly, 44 W. 28th St., New York—Gold, \$50.00; 36 Mums, six varieties in one vase.

William Duckham, Ononda, Madison, New Jersey—Cash, \$25.00; class not yet specified.

W. A. Manda, South Orange, New Jersey—Ornament set with precious stones, value, \$250.00; class not yet specified.

Knoeshell Bros. Co., Chicago—Gold, \$25.00; best vase carnations not less than 25 blooms any variety in commerce; must be grown in houses heated by hot water. Gold, \$25.00; to the exhibitor using hot water exclusively for heating, who wins the greatest number of prizes at the show.

Foley Manufacturing Co., Chicago—2 silver Cups each \$25.00; class not yet specified.

Viotor Bros., Chicago—Cash, \$25.00; class not yet specified.

MASSACHUSETTS HORTICULTURAL SOCIETY.

The January exhibition, held on the 25th inst. at Horticultural Hall, Boston, brought out some very interesting things in addition to the primulas, violets, carnations and vegetables grown under glass, for which provision was made in the prize schedule. The most notable exhibit was a group of beautiful specimens in pots of *Celsia Arcturus* from Wm. C. Ritchie, gardener to Mrs. J. M. Sears. This plant has never to our knowledge been shown in this form here, and it is a pity that so few plant growers were present to note its excellent qualifications for the florists' window when grown thus, compact and with several stocky spikes of brilliant yellow flowers to each plant. Mr. Ritchie was awarded a cultural certificate. Two plants of the same species were shown by Dr. C. G. Weld. W. A. Riggs showed blooms of *Leptosyne maritima*. These bright yellow flowers, not unlike small single sunflowers, should make an acceptable mid-winter cut flower.

T. T. Watt, gardener to Mrs. H. F. Durant, showed two novelties worthy of note—*Calceolaria fuchsiaeifolia* and *Schizocentron elegans*. The former, although not new, is seldom seen. The flowers are yellow and the foliage soft green; it has no marked value as a florist's subject. *Schizocentron elegans* or *Ileeria Mexicanum* (?) is a prostrate plant with small dark foliage and magenta pink blossoms, and makes a very pretty, drooping, pot or hanging-basket specimen. It was awarded honorable mention. *Corydalis Wilsoni*, shown by Walter Hunnewell, was another interesting novelty, with finely cut, very glaucous foliage and racemes of drooping yellow flowers, somewhat weedy in effect. It received honorable mention, as did also some superb specimen *Lorraine begonias* from R. & J. Farquhar & Co.

The primulas were very fine. On *sinensis* E. J. Mitton, Dr. C. G. Weld and Mrs. J. M. Sears; on *stellata* Mrs. J. L. Gardner; on *obconica* Dr. Weld, Mrs. Gardner and Mrs. Sears, were the prize winners in the order as named. *Primula Kewensis* was shown in fine form by Dr. C. G. Weld and Gen. S. M. Weld, Thos. Coles, gardener.

Violets were limited to two varieties, *Lady Hume Campbell* and *Princess of Wales*, the exhibitors being H. F. Woods, H. T. Calder, W. B. Goodnow and Mrs. F. Ayer. Carnations made a splendid show. Prizes were distributed mainly between S. J. Goddard, M. A. Patten and Backer & Co. Goddard's, Helen Goddard, *Rose pink Enchantress* and *Beacon*, Patten's *Winsor*, *Pink Patten* and *White Perfection* and Backer's *White Perfection* and Mrs. Patten were the most noteworthy. Wm. Nicholson had a splendid vase of *Afterglow*.

DETROIT FLORIST CLUB.

At the last meeting of the club the proposition to hold a flower show was abandoned. Nevertheless, next fall will bring forth a bigger and better display than ever before.

Twenty members accepted Theodore Mitchell's annual invitation to his home, where an inviting dinner and entertainment held them until a late hour.

LOUISIANA STATE HORTICULTURAL SOCIETY.

The fifth annual meeting of the Louisiana State Horticultural Society will be held in Minden, La., February 20, 21 and 22. The program will include discussions of subjects presented by the leading scientific and practical horticultural and agricultural men in the state. A representative of the United States Department of Agriculture will also be present.

The following subjects are among those on the program: Peach culture; The Cannery; Apple culture; Pecan culture; Good Roads; Cut Flowers; Rose culture; Bird Life; The Nursery; Tomato growing; Plant Diseases; Fig culture; Grape culture; Small Fruit; Hedge plants; Care of the Orchard; Trucking; Insect Pests; School Gardens; Fertilizers; Home Improvement; School Grounds; New Vegetables and Fruits; Horticulture and the Railroads.

There will be illustrated lectures at the night sessions. There will be reduced rates on all railroads. North Louisiana needs horticultural industries. Fruit and truck are profitable when cultivated intelligently. Come and join the movement for diversification along the lines of horticulture. The proceedings will be published and sent to all members. Annual membership fee \$1. Join the society at once and secure the publications.

C. D. OTIS, President,
Lake Charles, La.
F. H. BURNETTE, Sec'r-Treas.
Baton Rouge, La.

ST. LOUIS HORTICULTURAL SOCIETY.

The annual meeting of this society took place on January 21 at eight o'clock P. M. In the absence of the president Vice-President Gundlach presided. The officers of last year were re-elected: President, E. W. Mallinckrodt; vice-presidents, L. Matthews, Alex. Waldbart, J. B. Gazzam, J. H. Gundlach; treasurer, Fred C. Weber; secretary, O. G. Koenig. Executive committee: Henry Young, chairman; C. B. Nicholson, C. C. Sanders, Theo. Miller, F. H. Meinhardt, F. W. Brockman, F. C. Weber, A. Meyer, Jr., A. Jablonsky, Emil Schray, O. G. Koenig. The executive committee meet next week to arrange for a flower show to be held during March.

LENOX HORTICULTURAL SOCIETY.

The regular meeting of the Lenox Horticultural Society was held January 18, President Jack in the chair. The schedules for the August and fall exhibitions were adopted as read. S. Carlquist was awarded a diploma for a fine vase of *Celsia Arcturus*. The annual banquet will be held at Curtis Hotel, Saturday, February 15, and promises to excel any affair of the kind ever given by the society.

The annual ball took place in the Town Hall, on Jan. 23. A concert by Clark's orchestra opened the event. A fine supper was served and the company included many out-of-town guests.

GEORGE H. INSTONE,
Secretary.

TWIN CITY FLORISTS' AND GARDENERS' CLUB.

On Jan. 21, about sixty Twin City florists and gardeners met at Holm & Olson's store, St. Paul, Minn., and perfected an organization. Discussion of things pertinent to the trade made the meeting a valuable one.

E. Nagel of Minneapolis read a paper on Bedding Plants. In this he told something of his methods of handling the plants and of selling. The discussion of this paper brought out the fact that florists were doing bedding work too cheap, and a committee was appointed to endeavor to fix prices that would be more fair to the grower.

The next meeting of the club will be held at the Park Greenhouse in Minneapolis in February. Theodore Wirth is president and S. D. Dysinger is secretary.

THE AMERICAN ROSE SOCIETY. Some More Prizes.

There is offered a silver cup, valued at \$25.00, by H. F. Michell Co., seedsmen, of Philadelphia, Pa., for 50 blooms of *Kate Moulton* rose.

F. R. Pierson Co., Tarrytown, N. Y., offer a silver cup, valued at \$25.00, for the best new rose not in commerce nor yet exhibited before the American Rose Society.

There has been mailed to every florist or grower located in Chicago a copy of the schedule for the annual exhibition.

August Poehlmann, Morton Grove, Ill., is duly appointed chief of the Executive Committee to represent on the spot the American Rose Society.

Any entries, prizes or other matters should be forwarded to the secretary of the society.

BENJAMIN HAMMOND,
Fishkill-on-Hudson, N. Y.

Carnation Cuttings

Both standard varieties and novelties. Stock guaranteed to be first-class. Address,

S. S. SKIDELSKY

1741 North 18th Street, Philadelphia

New Violet BOSTON

In introducing this new variety to the trade I wish to state that I have been growing it in quantity for the past two years and do not hesitate to state that it is entirely distinct, a strong grower, a free bloomer, and the finest single violet in cultivation. Ready for distribution in April and May. Orders booked now, \$2 per 12; \$12 per 100; \$100 per 1000. 500 at 1000 rate.

WILLIAM SIM, CLIFTONDALE, MASS.

100,000 DAHLIAS

Premium Stock, guaranteed true to name. 500,000 large Flowering Gladioli, hundreds of colors and variations mixed. Wholesale prices on application. Order now for spring delivery. Catalogue free.

J. L. MOORE, Northboro, Mass.

DAHLIAS. Now is the time to place your order for bulbs which will insure you getting named varieties in any quantity; prompt delivery.

DAVID HERBERT & SON,
Successors to L. K. Peacock, Inc.

ATCO, N.J.

Seed Trade

Reference was made in last week's issue to possible governmental control or supervision of the seed business, and while such supervision if exercised by persons ignorant of the business would be intolerable, yet, on the other hand, if under the supervision of an able and thoroughly practical horticulturist it might not prove an unmix'd evil. Assuming that government supervision is inevitable, the probable modus operandi would be the establishment of a bureau under the control of the secretary of agriculture and appointed by him.

Now whether this bureau would prove a success or failure, would depend largely on the man appointed as its chief. Presuming that he would be some practical seedsman, having the best interests of the seed trade at heart, his administration might be enduring, and in one respect at least he might render the trade some practical benefit—that is, in the field of nomenclature. Such a bureau could be modeled in some respects on the lines of the Patent Office, and any seedsman having a new or an improved strain he wished to introduce, should be required to submit the same to this bureau, and if after a thorough test it was found to be distinct or a marked improvement of an existing type a certificate would be issued giving permission for its introduction under whatever name the introducer might select, and requiring any one listing it to do so under the name given by the introducer, which would protect him in his proprietary rights much as the issuance of a patent to an inventor as an extra protection, a penalty in the form of a fine sufficiently heavy to make this class of piracy an expensive luxury could be imposed, such penalty to be recoverable in an action instituted by the introducer before any United States court.

No doubt objections can be urged against this plan, chief among which are the known variations in types in different soils and under varying climatic conditions. But there is no reason to suppose that these variations would be any more marked in new or improved strains of old varieties than in existing types, and it would effectually stop the multiplication of names which is the bane of the seed trade.

It was stated in last week's issue that the forthcoming Canners' Convention, in point of attendance and extent of machinery exhibits, would probably eclipse any previous convention, but information just received indicates that the machinery exhibit will not equal that at Buffalo last year. This is mainly due to the inadequate space available for that purpose.

It has been customary of recent years for the city chosen as the place for the convention to raise a fund for the entertainment of the canners. Buffalo last year raised \$2,000 for this purpose, and never has any city until now done otherwise. It has remained for Cincinnati to establish a precedent in this respect. Through the secretary of the Cincinnati League the hat has been passed, asking the Machinery and Supplies Association for subscription, and it goes without saying that

this action of the Cincinnati League has been received with ill grace. It has been the custom for the Machinery and Supplies Association to tender the canners some sort of an entertainment, and most of them think their expenses heavy enough without being called to contribute to the fund of any local organization. To say the least, this begging by the Cincinnati League is humiliating to their city and in very bad taste. It would be interesting to know who the instigators of this scheme are.

G. S. May has started in business in San Francisco under the name of the May Seed Co. He is located on Market street.

The Nashville Seed Company, Nashville, Tenn., has taken more spacious quarters at 215 N. Market street.

AMERICAN SEED TRADE ASSOCIATION.

The executive committee of the American Seed Trade Association met at the Auditorium Annex, Chicago, on Jan. 21. Members in attendance were President George A. Green, Vice-President M. H. Duryea, Secretary and Treasurer C. E. Kendel and Messrs. Henry W. Wood, C. S. Burge, Leonard H. Vaughan, Chas. N. Page and W. S. Woodruff. Detroit has been selected as the meeting place for the next convention, June 23-25. Headquarters have not yet been selected. The following resolutions were adopted:

The executive committee of the American Seed Trade Association recommends that its members still further emphasize and publish the Disclaimer by having it printed on all stationery, including letter-heads, bill-heads, quotation sheets, acceptances, labels and packages and to disseminate same to all merchant customers possible and to supply merchants with Disclaimer cards to be hung in a conspicuous place in the sales-room.

Cards will be furnished by the secretary free to members on request and to others at 10c. per copy, postpaid. C. E. KENDEL, Sec'y.

CLUB AND SOCIETY NOTES.

The State Horticultural Society met at Van Buren, Ark., on Jan. 21-23. W. K. Tipton spoke interestingly on evergreens.

The Florists' Club of Cleveland, O., have their carnation exhibition February 10. Certificates of merit will be awarded to all worthy exhibits. Isaac Kennedy is secretary.

The Southern Minnesota Horticultural Society at its annual meeting on the week of Jan. 12 elected L. P. H. Highby president and O. M. Peterson secretary, both of Albert Lea.

The nurserymen of Ohio organized at Columbus on January 15, with officers as follows: President, J. W. McNary; vice-president, Robert George; secretary, W. B. Cole, Painesville; treasurer, W. N. Scarff.

The fourth lecture before the American Institute of New York was on January 29, by Dr. G. H. Earp Thomas of New Zealand; subject, The bacterial life of the soil and relation of leguminous plants to same.

The Horticultural Society of Mad-

GLADIOLI

I can satisfactorily supply your wants for Gladioli for forcing or outdoor planting. Mixtures, color sections or named varieties of exceptional beauty.

Write for Prices

ARTHUR COWEE

Gladiolus Specialist

Meadowvale Farm, BERLIN, N. Y.

HYACINTHS, TULIPS, NARCISSI AND OTHER BULBS

ROMAN HYACINTHS and the true PAPER WHITE GRANDIFLORA

Ask for our Wholesale Trade List at Hillegom

K. VELTHUYS, Hillegom, Holland
Rep. by FELIX BOSCH, 260 Claremont St., Boston

son, Wis., have elected new officers as follows: President, G. W. Reigle; vice-presidents, Edwin Sumner, Preston Brown; treasurer, F. F. Broman; secretary, James Milward, University of Wisconsin, Madison.

The St. Catherines Horticultural Society, Ont., at the annual meeting, elected officers as follows: President, W. B. Burgoyne; vice-president, W. H. Bunting; secretary, Miss L. Ratcliffe; treasurer, C. A. Hesson. The financial statement showed that during the past year the society had expended on flowers, fruit and vegetable shows almost \$3000.

The Worcester County Market Gardeners met at Horticultural Hall, Worcester, Mass., on Jan. 25 and elected the following officers: President, A. S. Wolfe; vice-presidents, H. W. Anderson, H. E. Stevens, C. Webb; secretary, H. R. Kinney. The subject of cucumber raising came up for much interesting interchange of opinion. Alfalfa raising was touched upon. Mr. Kinney said if the farmers of New England had devoted as much attention to red clover as they had to alfalfa they would be a great deal better off.

\$3000 PER ACRE IN TOMATOES

Outdoor culture. With my Concrete or Cement Plant Protector, Patent pending. Set plants six weeks earlier and get hothouse prices. Will sell Town Rights and furnish mold. Send no stamp for circular.

J. H. HALEY,

MUNITH, MICH.

CATALOGUES RECEIVED.

Champion City Greenhouses, Good & Reese Co., Proprietors, Springfield, O.—Spring Trade List for 1905 of "The Largest Rose Growers in the World."

Dingee & Conard Co., West Grove, Pa.—New Guide to Rose Culture, 1905. The front cover of this popular catalogue shows a stunning bloom of the new rose J. B. Clark, and on the back a spray of the beautiful Tausendschon, both on a gold background, and the effect is very striking. The beauties of a very extended list of roses and other plants are vividly set forth in the contents.

INCORPORATED.

Gulf Coast Agricultural and Horticultural Development Co., Jacksonville, Fla.; C. A. Burton, O. E. Tandy, R. Y. Duncan; capital, \$50,000.

The report of Frederick L. Olmsted for the beautification of Holyoke, Mass., recommends an extension of Prospect park along the bank of the Connecticut river to the city line. An expenditure of \$450,000 would be required.

BEGONIAS

	Doz.	100
Single Named colors	40c	\$2.50
" Mixed "	35c	2.25
Double Named "	65c	5.00
" Mixed "	50c	4.00
Gloxinias Named "	50c	4.00
" Mixed "	40c	2.50

WM. ELLIOTT & SONS

201 FULTON ST., NEW YORK

WIBOLTT'S SNOWBALL CAULIFLOWER-SEED

No. 34 is the earliest of all Snowballs, the most compact, the surest header, is giving the largest and snow-white heads, and is the best keeper in dry-weather. Demand it through your seed-firm or direct from

R. WIBOLTT, NAKSKOV, DENMARK

Cyclamen

Superb English Strain Second to none in size of flowers.
 Giant Crimson.
 " Pink
 " White
 " White with Claret base.
 " Mauve.
 " Salmon-Queen.
 " New Fringed.



100 seeds \$1; 1000 seeds \$9.

H. E. FISKE SEED CO.

12 and 13 Fanuell Hall Square, BOSTON MASS.

CAULIFLOWERS & CABBAGE SEED

HJALMAR HARTMANN & CO.,
 12 Stormgade, COPENHAGEN, DENMARK.

ESTABLISHED 1802



Send for our Wholesale Catalogue of Seeds for Florists and Market Gardeners, ready in a few days.

	Per doz.	Per 100
GLADIOLUS PRIMULINUS	\$8.00	\$60.00
PRIMULINUS HYBRIDS	3.00	20.00

J. M. THORBURN & CO.
 33 Barclay St., through to 38 Park Place
 NEW YORK

Everything of the Highest Grade

"QUALITY IS REMEMBERED LONG AFTER PRICE IS FORGOTTEN."
 WHAT QUALITY MEANS.

Quality means the best and finest types procurable in their respective classes. We go to specialists for our flower seeds. Our customers, the Florist the private gardener demand the highest grade. We have no cheap catalogue trade. "Quality" may mean a little higher in price. "Quality" in fact means "Quality" and we know that when you buy from us you get it—and our customers know it too. Catalogue now in press; 40 pages. Write for one its FREE. We sell bulbs too.

ARTHUR T BODDINGTON,
 SEEDSMEN
 342 West 14th St., NEW YORK.

	Pkt.	Oz.
Ageratum Blue Perfection	\$0.15	\$0.50
Alyssum Little Gem	.10	.35
Ca dy Tuft Empress	.10	.20
Bellis Snowball	.25	
" Longfellow	.25	
Salvia Splendens	.25	1.35
" Bonlire	.25	2.50
Verbena Mammoth Mixed	.25	1.50

BRIDGEMAN'S SEED WAREHOUSE
RICKARDS BROS., Props.
 37 East 19th St., NEW YORK CITY

BRASLAN SEED GROWERS CO.
 GROWERS FOR THE
 WHOLESALE TRADE ONLY

SAN JOSE, - - CALIFORNIA
Burpee's Seeds
 PHILADELPHIA

Blue List of Wholesale Prices mailed only to those who plant for profit

BAMBOO CANES TOUGH AND STRONG
 6 ft. long—\$1 per 100; \$6 per 1000; \$11 per 2000

They cost about 10 per cent. more than other kinds, and they are 10 times better.

STUMPP & WALTER CO., - 50 Barclay St., New York

RELIABLE SEEDS—SOW NOW

	Tr.	6 Tr.
Alyssum Carpet Queen, real dwarf for pots only, no equal....	\$0.25	\$1.25
Begonia Gracilis Luminosa, new	0.50	2.50
Erfordia, beautiful.....	0.50	2.50
Lobelia, new Trailing Hamburgia	0.30	1.50
Petunia, Double Fringed Giants... Single Fringed Giants...	1.00	5.00
	0.75	4.00
Phlox, best for pots, Fireball, Roseball, Snowball, each color.....	0.25	1.25
Salvia Fireball, new, a fine potter	0.50	2.50
Stocks, German 10 weeks: Blood-red, Lavender, Pink, Purple, White, each color.....	0.50	2.50
Verbena Mammoth: Pink, Purple, Scarlet, Striped, White, each	0.25	1.25

My New Price List Ready for the Asking

O. V. ZANCEN

Seedsman, HOBOKEN, N. J.

Best Quality Fall Bulbs

It is to your advantage to place your order early. Send us a list of your wants and we will quote you rock-bottom prices. Copy of our Florists' Bulb Catalogue will be sent upon request. Catalogues now ready.

VICK'S SUPERB PANSY SEED

All the best varieties in separate colors

VICK'S SUPERB MIXTURE

the best strain from all the leading named sorts

1-8 oz. 75c. 1-4 oz. \$1.50 Ounce \$5.00

JAMES VICK'S SONS, Rochester, N. Y.

CYCLAMEN

Farquhar's Giant Strain

Unsurpassed for size of flowers.

Giant Crimson Giant Pink
 Giant White Finest Mixed
 Giant Excelsior, White with Claret Base

100 seeds, \$1.25; 1000 seeds, \$10.00.

R. & J. FARQUHAR & CO.

6 & 7 So. Market St., Boston, Mass.

BRECK'S SEEDS

For Farmer, Market Gardener and Florist
 New Crop High Grade
 Catalogues mailed free on application

Joseph Breck & Sons Corp.
 47-54 NO. MARKET ST., BOSTON, MASS.

JUST ARRIVED

LARGE SHIPMENT OF
High-Grade SCOTCH SOOT.

We have the Stott Double Nozzle
THOMAS J. GREY CO.

32 & 33 So. Market St., BOSTON

C. C. MORSE & CO.

Address all communications to our permanent address
 48 to 56 Jackson St., San Francisco, Cal.

The Largest Seed Growers in the United States

Easter Azaleas and Spring Forcing Plants



Our stock this season is handsomer than ever. Anybody in want of a quantity will do well to inspect our plants before placing their order. We have only popular American varieties: **Schryvertana**, **Simon Mardner**, **Vervaeana**, **Mme. Van der Cruyssen**, **Deutsche Perle** and others.

	Per doz.	Per 100		Per doz.	Per 100
8-10 in. diam.	\$3.50	\$25.00	15-16 in. diam.	\$9.00	\$75.00
10-12 "	4.50	35.00	16-18 "	12.00	90.00
12-14 "	6.00	45.00	18-20 "	25.00	200.00
14-15 "	7.50	60.00	20-24 "	36.00	300.00

Order early to save heavy express charges; impossible to ship by freight in cold weather.

FORCING ROOTS AND POT GROWN SHRUBS

	Doz.	100	1000		Doz.	100	1000
Azalea Mollis , \$4.00, \$9.00, \$12.00				Deutzia gracilis , pot grown	\$12.00		
" " standard form	12.00			" Lemoinei "	15.00		
" " chinensis	12.00			Gladolus , The Bride			\$7.50
" " Anthony	12.00			" rubra			6.50
" Rustica	12.00			Katmia latifolia , fine budded plants,	\$9.00, 12.00		
Very handsome budded plants.				Lilacs pot grown	9.00		
Crataegus , Paul's Scarlet (Double scarlet Hawthorn) pot grown,	\$12.00, 18.00			" Lily of the Valley , Berlin Pips			14.00
Dielytra spectabilis , large clumps,	\$6.00			" " " Hamburg Pips			12.00
Rhododendrons , handsome budded plants in fine forcing varieties, \$9, \$12, \$15, \$18, \$24, \$30 per dozen.				Viburnum opulus (Snow-ball) bush form, pot grown	6.50		

Roses Grown in Our Nursery for Easter Forcing

- BABY RAMBLERS**, tree form, pot grown, 50c. each
- Bushy form fine field grown plants
- CLOTHILDE SOUPERT**, field grown, 2 year old
- DOROTHY PERKINS**, strong field grown plants, 2 years old, 7-8 feet
- HERMOSEA**, field grown, fine for pots, 2 years old
- RED KAISERIN**, strong 2 year old field grown plants

Dozen	100
\$5.00	\$15.00
2.00	15.00
1.50	12.00
3.00	20.00
1.50	12.00
3.50	25.00

- LADY GAY**, strong field grown plants, with well ripened wood, 2 years

Dozen	100	1000
\$3.50	\$25.00	

- H. P. ROSES**, imported, field grown, 2 years old

12.00	\$100.00
-------	----------

Capt. Christy, Duchess of Edinburgh, Gen. Jacqueminot, Mme. Gabriel Luizet, Mrs. John Laing, Perle des Blanches, Ulrich Brunner, Caroline Testout, Frau Karl Druschki, La France, Magna Charta, Paul Neyron, Rothschild.

KENTIAS

The handsomest lot in the country - all sizes, from 15 inches to 15 feet. Inspect our stock before buying.

BOXWOOD, Standard

All sizes from \$1.00 to \$5.00 each

BOXWOOD, Pyramidal

These plants are conceded to be the finest ever imported to this country. (Exceptional value.)

2 ft.	\$.75 each	4 ft.	\$3.00 each
2 1/2 ft.	1.00 each	4 1/2 ft.	4.00 each
3 ft.	1.50 each	5 ft.	5.00 each
3 1/2 ft.	2.00 each	6 ft.	6.00 each

BOXWOOD, Bush

Handsome, bushy specimens.
10-12 in. 15c each 15-18 in. 35c each
18-15 in. 25c each 18-22 in. 75c each

BAY TREES

We have a large number in all sizes. Ask for prices.

VISITORS INVITED.

ASK FOR CATALOGUE.

BOBBINK & ATKINS, Nurserymen and Florists, Rutherford, N. J.

Just Received in Splendid Condition

15,000 AZALEAS

in all sizes and varieties

25c. up to \$2.00 each

Also Kent as, Rubbers, Araucarias, Pandanus, Boxwood, Euonymus, Crotons, Areca and Eurya latifolia.

Extra good value in large

Specimen and Decorative Palms

A. LEUTHY & CO.

Perkins Street Nurseries, Roslindale, Mass.

GODFREY ASCHMANN

Importer and Wholesale Grower and Shipper

1 Araucaria Excelsa, Comp. etc., Palms, and Glauca; Kentia Forsteriana and Belmoreana; Azalea Indica, etc. Cultivator of Boston, Scottii, Barrowsii, Elegantisima and Whitmanii Ferns. Ferns for Fishes, Cocos, etc. Write for prices.

1012 Ontario St., Philadelphia

JOHN SCOTT

Grower of PALMS, FERNS and Other Decorative Stock

NEPHROLEPIS SCOTTII All the Year Round

Rutland Road and East 45th St.

Telephone 2890 Bedford BROOKLYN, N. Y.

NEP. WHITMANI

2 1/4 in., \$5.00 per 100

NEP. WHITMANI

3 1/2 in., \$25.00 per 100

BOSTON FERNS

2 1/4 in., \$3.00 per 100

H. H. BARROWS & SON Whitman, Mass.

FERNS

Boston, 4 inch 12c, 5 inch 25c.

Pierstonii, 3 inch 8c.

Elegantissima, 2 1/4 inch 6c, 3 inch 10c, 4 inch, 15c.

BAUR FLORAL CO., Erie, Pa.

ANTON SCHULTHEIS

Wholesale Plant Grower,
College Point, - New York.

Price List of Foliage, Flowering and Decorative Plants sent free on application.

AZALEAS FOR FALL DELIVERY

The best that are grown, also Palms for Spring or Fall delivery furnished by AUGUST HAERENS, Somergem, Belgium. Orders hooked now. Address the American representatives.

AUGUST ROLKER & SONS, New York
31 Barclay Street, or P. O. Box 752

DREER'S SUPERB DOUBLE PETUNIAS



For half a century we have been making a specialty of **DOUBLE PETUNIAS** and our strain is accepted as second to none, either here or in Europe. We annually plant many thousand seedlings from which only the finest double fringed forms are selected for propagating purposes, thus improving the strain every season. We offer fifteen distinct varieties.

3-inch pots, 75c per doz.; \$6.00 per 100; the set of 15 for \$1.00.
2 1/4 inch pots, 60c per doz.; 4.00 per 100; the set of 15 for .75.

SEED OF OUR SUPERB STRAIN OF FRINGED PETUNIAS, Double, 75c per 500 seeds; \$1.50 per 1000 seeds. Single, 50c per trade packet; \$1.00 per 1 lb oz.; \$1.50 per 1/2 oz.

Our Quarterly Wholesale List offers a full line of seasonable Plants, Seeds and Bulbs.

HENRY A. DREER, PHILADELPHIA, PA.

GERANIUMS

Our 1908 illustrated GERANIUM catalogue is being mailed to the trade. It is the most beautiful and comprehensive that we have ever sent out. It contains descriptions of over 200 varieties, including the best Standard sorts, New Varieties and Novelties, gathered together from the leading introducers of America, England, Germany and France, making a collection which is the most complete ever offered to the American trade. Mailed free to the trade; if you do not get one write us, enclosing business card or letterhead. See last week's issue for miscellaneous stock, including Dahlia roots and Pelargoniums. Visitors always welcome. Cash with order.

R. VINCENT Jr. & SONS COMPANY
White Marsh, Md.

NEW—A MONEY MAKER—NEW CARTER'S DOUBLE BLUE LOBELIA

\$2.50 per doz., \$18.00 per 100

CASH WITH ORDER PLEASE. **J. FULLER, 31 Orchard St., LEOMINSTER, MASS.**

CANNAS

Send for our List and Prices

The CONARD & JONES CO.
WEST GROVE, PA.

ROBERT CRAIG CO.

ROSES, PALMS,

and Novelties in Decorative Plants

MARKET and 49th STREETS., PHILADELPHIA, PA.

THE FINEST

Lily of the Valley Excellenta

From cold storage. Only few cases left. Please order at once. \$32.00 per case of 2000 fine pips.

JOHN SCHEEPERS & CO.
4 & 6 Old Slip, - - NEW YORK.

LILIUM AURATUM

9-11 \$75 per 1000

ROSEUM and RUBRUM

9-11 \$65 per 1000

MULTIFLORUM

7-9 \$45 per 1000

D. RUSCONI, 128 West 6th St, CINCINNATI, OHIO

Keep Your Eye Open

FOR BARGAINS IN GOOD STOCK

See the **BUYERS' DIRECTORY** and **READY REFERENCE GUIDE.** Pages 152, 153, 154, 155.

Everything offered in this paper is listed there.

Look it over before buying and, in ordering please refer to advertisement in

HORTICULTURE

ORCHIDS

Largest Importers, Exporters, Growers and Hybridists in the World

Sander, St. Albans, England
and 235 Broadway, Room 1
NEW YORK CITY

... ORCHIDS ...

Just to hand, C. Trianae, C. labiata, C. Mossiae, C. Intermedia, C. Schroderae, C. Speciosissima, C. Cirina, C. Giskelliana, Laelia Aocceps, L. Albida, L. majalis, L. Autumnalis, Epidendrum Vittelinum majus, E. Cooperianum, Oncidium Crispum, O. Varicosum, O. Cavendishianum, O. Luridum, Odonto. Citrosomum. To arrive in a short time, C. Dowiana, C. Aurea, C. Warnarii, Miltonia Vexillaria.

CARRILLO & BALDWIN SFGAUCUS, N. J.

ORCHIDS for Spring Delivery

NEW IMPORTATIONS

Cattleyas, Laelias, Oncidiums, etc.

WRITE FOR PRICES

Now is the time to Pot Orchids. Pest Quality of Peat, Moss and Ba-Kets on hand.

JOSEPH A. MANDA, 191 Valley Road, WEST ORANGE N. J.

Write at once for our quotations on all

ORCHIDIMPORTATIONS

FOR 1908 DELIVERY

JULIUS ROEHRS CO.,

The Orchid Nurseries, Rutherford, N. J.

ORCHIDS

We are at present booking orders for freshly imported Orchids for delivery 1908, of all leading kinds at reduced prices. We have just received the following:— Oncidium Sarcodes, O. Forbesii, O. Tigrinum and Sophronites, Grandiflora and Coccinea.

LAGER & HURRELL, Summit, N. J.

ORCHIDS

The largest importation of Orchids ever received in this country WILL ARRIVE next spring from Brazil, Colombia and Venezuela. If you intend putting in stock wait for these to arrive and we will quote the Lowest Prices in America.

ORDONEZ BROS., - Madison, N. J.

JAPANESE
THE YOKOHAMA NURSERY CO.
31 BARCLAY STR. NEW YORK.
LILIES
PLANTS
BAMBOO STAKES

Prices Quoted in these Columns are for Dealers Only. When Writing to Advertisers Please Mention **HORTICULTURE.**

Wholesale Cut Flowers

Killarneys, Valley, Carnations in large lots at lowest market prices. Consignments solicited of Ivory, Maids and Beauties. Settlements weekly.

JAMES J. HARTY & CO.,

1312 G St., N. W. WASHINGTON, D. C.

A Fine Assortment of ==AZALEAS==

Extra fine lot of **FIREFLY** in bloom from
NOW UNTIL EASTER

WRITE FOR PRICES

MAJOR BONNAFFON

The best all 'round Yellow Chrysanthemum. Strong stools,
\$5.00 per 100

W. W. EDGAR CO., Waverley, Mass.

NEWS NOTES.

Hitchings & Co. have removed to their new plant, Spring and Louisa streets, Elizabeth, N. J.

Joseph Foerster, formerly with George Reinberg, has taken a stand at the Flower Growers' Market, Chicago.

L. A. Green of Wood River, Neb., has purchased 22 acres of land at Kearney and will soon start in the nursery business there.

W. T. Twomey of Roslindale, Mass., while driving near the city stone yard recently, was attacked by two dogs and his arms were severely lacerated before help came.

William Ferguson of Haverhill, Mass. has formed a partnership with W. J. Kingsbury of Derry, N. H., who recently purchased the Smith greenhouses in that town.

Miss Gertrude Jones has purchased land in Brookfield, Mo., and will build a greenhouse thereon. She has engaged as assistant George Gatzkow of Washington Court House, O.

The new greenhouse at City Park, New Orleans, is completed. The work has been under the supervision of Julius Koch of the Park Improvement Association, and the house and its appointments are among the finest in the South. About \$12,000 have been expended.

The annual Boston Flower Market Exhibition will be held at 1 Park St., Boston, Feb. 29, 1908. Premiums and prizes to the value of \$500 are offered for new and standard varieties of carnations, roses, violets, etc. For list address Geo. Cartwright, 1 Park St., Boston. Committee of arrangements: W. H. Elliot, Peter Fisher, S. J. Goddard, E. Allen Pierce, Alex. Montgomery, M. A. Patten, Wm. Nicholson, E. Sutermeister, Wm. Sim.

The American Nursery Company has acquired all the real estate, property, business and good will of the well-known F. & F. Nurseries, Springfield, N. J., the Bloodgood Nurseries, Flushing, L. I., Frederick W. Kelsey, New York City, and the N. J. & L. I. Nurseries. These old-established and successful concerns will hereafter be

EXTRA FINE BOXWOOD \$17.50 per CWT.

FANCY FERNS, A No. 1 Quality, \$1.50 per 1000
GREEN CALAX \$1 per 1000, \$7.50 per 10,000
BRILLIANT BRONZE \$1 per 1000, \$8.50 per 10,000

Headquarters for **HARDY FERNS, MOSS, LAUREL, PRINCESS PINE, FESTOONING, Etc.** See Our Cut Flower Ad.

HENRY M. ROBINSON & CO., FLORISTS' SUPPLIES 15 Province St., and 9 Chapman Pl., BOSTON

conducted as branches of the company under the same local management as heretofore. The officers of the company are: Frederick W. Kelsey, president; William Flemer, vice-president and treasurer; Theodore Foulk, vice-president; P. H. Goodsell secretary.

Judge Heisley, in the Supreme Circuit Court set aside a recent jury verdict and granted a new trial in the case of W. A. Manda against the city of Orange, which condemned part of Manda's property for its water line right of way. A substantial price was offered Manda for the tract, and when he refused the offer a commission was appointed to fix a proper price and did so, setting \$700 as the figure. Manda appealed to the Supreme Court and a couple of months ago a jury said the property should be valued at \$1600 instead of \$700. Manda was satisfied with this, but Orange was not and asked for a new trial. The argument came up before Judge Heisley on Tuesday and today he granted the request.—Newark, N. J., News, January 23.

You will find something worth reading on every page of HORTICULTURE.

KORAL SCRIPT LETTERS AND EMBLEMS

ONCE USED ALWAYS USED
For sale by all first class supply houses. Made by

KORAL MFG. CO.
26 Hawley St., Boston

E. A. BEAVEN
Southern Wild Smilax,
Log Mosses,

Natural and Perpetuated — at Wholesale,
EVERGREEN, ALABAMA.

BOSTON FLORIST LETTER CO.

Manufacturers of FLORISTS' LETTERS

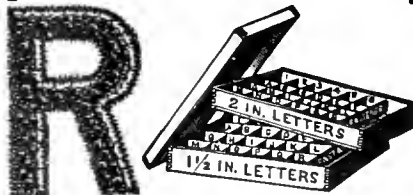

This wooden box nicely stained and varnished, 18x30x12, made in two sections, one for each size letter, given away with first order of 500 letters

Block Letters, 1 1/2 or 2 inch size per 100, \$2.
Script Letters, 3. Fastener with each letter or word. Used by leading florists everywhere and for sale by all wholesale florists and supply dealers

N. F. McCARTHY, Manager
66 Pearl Street, BOSTON, MASS.

J. Kopelman & Co.

Wholesale Dealers in

Cut Flowers and Florists' Supplies

**EVERGREEN
AND FERN LEAVES**

OF ALL KINDS.

21 Washington St., PROVIDENCE, R. I.

Telephone Connection.

The "Japana" Cut Flower Holder

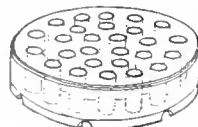

A handy article for florists. Sells to the trade on sight. Made of glass in three sizes. The "Anglais" Table Decoration, something entirely new, long needed. The florist and housewife will appreciate this article, as it simplifies the art of table decorating

Ask for catalog.

M. V. CARNSEY, Dept. F,
130 Waiola Ave., La Grange, Ill.

JOHN BREITMEYER'S SONS

Cor. Miami and Gratiot Aves.
DETROIT, MICH.

Artistic Designs . . .
High Grade Cut Blooms

We cover all Michigan points and good sections of Ohio, Indiana and Canada

P. J. and J. E. HAUSWIRTH

232 Michigan Ave.

CHICAGO

AUDITORIUM ANNEX

Tel. Harrison 585

SAMUEL MURRAY Florist

Coates House Conservatory
1017 BROADWAY, KANSAS CITY, MO
Both 'Phones 2670 Mafn

FRED C. WEBER FLORIST

4326-28
OLIVE STREET

ST. LOUIS, MO.

Established 1873

Long Distance Phone Bell Lindell 676



GUDE BROS CO
FLORISTS
1214 F ST NW
WASHINGTON DC

WASHINGTON,
D. C.

GUDE'S

Geo. H. Cooke FLORIST

Connecticut Avenue and L Street
WASHINGTON, D. C.

The Park Floral Co.

J. A. VALENTINE
Pres.

DENVER, COLORADO

WILLIAM L. ROCK FLOWER CO.

KANSAS CITY, MO.

will carefully execute orders for Kansas City and any town in Missouri or Kansas.

ALBANY, N. Y.

EYRES

Flowers or Design Work

DELIVERED IN ALBANY AND VICINITY ON TELEGRAPHIC ORDER.

11 NORTH PEARL ST., ALBANY, N.Y.

FIRE RECORD.

Wm. F. Regan, florist, of Lawrence, Mass., had his stock badly damaged by smoke from a fire in an adjoining building. He was well insured.

A greenhouse on the estate of F. P. Stone, Wellesley, Mass., was destroyed by fire early on the morning of January 28. The loss is estimated at \$5000.

Fire that started in the boiler room of the Texas Nursery Co., Sherman, Tex., destroyed a portion of the greenhouses, entailing a loss of \$1,000. No insurance.

Fire destroyed the greenhouse and stable of Frank Curtiss, New Haven, Pa., on January 11. Cause unknown. Loss about \$5,000, partially covered by insurance.

BUSINESS CHANGES.

Robert Schenk succeeds the Columbus Floral Co., at Columbus, O.

Mr. Williams of Columbus, O., succeeds W. R. Rhea as manager of the McRae-Jenkinson Co., Cheswick, Pa.

V. L. Schuluraff, who succeeds to the business of the Schuluraff Floral Co., is located at Floral Park, Erie, Pennsylvania.

A. T. Shotwell has purchased the interest of his partner, J. L. Graves, at Fargo, N. D. Mr. Graves will locate in California.

NEW RETAIL STORES.

H. A. Fisher, Battle Creek, Mich.
Morse Floral Co., New Haven, Conn.
Minnie C. Wilson, 18 So. Common St., Lynn, Mass.

James W. Dunford, Broadway and Franklin Av., St. Louis, Mo.

LEADING RETAIL FLORISTS—
Index by Towns will be found in Buyers' Directory.



Send flower orders for delivery in

BOSTON

and all

NEW ENGLAND POINTS

THOS. F. CALVIN

124 Tremont St., Boston

TRANSFER

Your orders for flower or plant delivery in Eastern New England to

JULIUS A. ZINN,

2 Beacon St., Boston.

Fine Design Work a Specialty

YALE

Orders for flower deliveries to Yale College and all other Connecticut

points carefully filled and delivered by

J. N. CHAMPION & COMPANY

1026 CHAPEL STREET

NEW HAVEN, CONN.

ATLANTA FLORAL CO.

41 Peachtree Street,

ATLANTA GEORGIA.

Florists

Out of
Town

Taking orders for delivery in
New York or Vicinity
can have them filled in best
manner and specially delivered by

Thomas Young, Jr.

41 W. 28th St., New York City

ALEX. McCONNELL

571 FIFTH AVENUE
NEW YORK CITY

Telegraphic orders forwarded to any part of the United States, Canada, and all principal cities of Europe. Orders transferred or intrusted by the trade to our selection for delivery on steamships or elsewhere receive special attention.

Telephone Calls, 487 and 488 38th St.
Cable Address, ALEXCONNELL

WILLIAM H. DONOHUE

FLORAL DECORATOR

17 East 28th St., New York

Special Attention to Theatre and Steamer Orders, and reliable deliveries guaranteed.

DAVID CLARKE'S SONS

Deliver orders from any part of the country to
New York City

Or OUT-GOING STEAMERS

Write or telegraph

2139-2141 Broadway, New York
Telephone 1552-1553 Columbus

PROMPT DELIVERY IN BOSTON

AND ALL NEW ENGLAND POINTS

HOUGHTON & CLARK

396 Boylston St., Boston, Mass.

Flower Deliveries

In Brooklyn and other Long Island Points New York City, New Jersey etc. At Theatres, Hotels, Steamers or Residence's.

WILSON

Fulton St. and Greene Ave., Brooklyn, N.Y.

YOUNG & NUGENT

42 West 28 St., NEW YORK

"FLOWERS BY TELEGRAPH"

William J. Smyth FLORIST

Cor. Michigan Ave. and 31st St., CHICAGO

We ship to all points in Illinois and Iowa.

Phones: Douglas 744, Douglas 523, Douglas 740

JACOB SCHULZ, 644 Fourth Ave., LOUISVILLE, KY.

Cut Flowers of BEST QUALITY in season delivered promptly to any address.

Write, Telegraph or Telephone.

Cumberland and Home Phones 223 and 984

CARNATIONS - Rooted Cuttings

Healthy, well-rooted stock the product of the most reliable growers of this locality

	Per 100	Per 1000		Per 100	Per 1000		Per 100	Per 1000
White Enchantress,	\$6.00	\$50.00	Enchantress,	\$2.50	\$20.00	Harlowarden,	\$2.00	\$18.00
White Perfection,	3.00	25.00	Helen Goddard,	2.50	20.00	atten,	2.50	20.00
White Lawson,	2.00	18.00	Lawson,	2.00	18.00	Fenn,	2.00	18.00
Queen Louise,	2.00	18.00	Beacon,	6.00	50.00	Red Sport,	2.00	18.00
Winsor,	6.00	50.00	Victory,	3.00	25.00	Boston Market,	2.00	18.00
Aristocrat,	6.00	50.00	Craig,	3.00	25.00	Joost,	2.00	18.00
Rose Pk. Enchantress,	3.50	30.00						

NEW CROP SEEDS
ASPARAGUS PLUMOSUS NANUS \$4.50 per 1000.
 Special prices on large quantities. Greenhouse Grown, Hard Selected

MRS. JARDINE: the sensational new pink rose: 2 1/2 inch pots: **\$30.00 per 100, \$250.00 per 1000**
Orders Booked Now

S. S. PENNOCK-MEEHAN COMPANY, "THE" Wholesale Florists of **PHILADELPHIA**
 1608-1620 Ludlow Street, - - - - -

EVERYTHING SEASONABLE IN
CUT FLOWERS
EDWARD REID, Wholesale Florist
 1526 Ranstead St., PHILADELPHIA
 STORE CLOSES 8 P. M.

CHAS. W. McKELLAR
 51 WABASH AVE., CHICAGO
 Western Headquarters for Choice Orchids
 Valley, Roses and all Cut Flowers

PETER REINBERG
 WHOLESALE
CUT FLOWERS
 51 Wabash Av., Chicago, Ill.
 In writing advertisers mention Horticulture

CUT FLOWER BOXES
EDWARDS FOLDING BOX CO
 MANUFACTURERS
 PHILADELPHIA, PA.

AMERICAN BEAUTY and all other **ROSES**
LILY OF THE VALLEY, CARNATIONS
WELCH BROS., 226 Devonshire St., Boston, Mass.

TRUMPET MAJORS
 Extra Quality Any Quantity
W. E. McKISSICK WHOLESALE FLORIST
 PHILADELPHIA
 1619-1621 RANSTEAD ST.

DAILY CONSIGNMENTS
 From 40 to 60 Growers
 We can care for your cutflower wants to advantage.
E. F. WINTERSON CO.
 45-47-49 WABASH AVE., CHICAGO

ROBERT J. DYSART,
 Public Accountant and Auditor
 Simple methods of correct accounting especially adapted for florists' use.
 Books Balanced and Adjusted
 Merchants Bank Building
 28 STATE ST., BOSTON
 Telephone, Main 38

WHOLESALE FLOWER MARKETS
 TRADE PRICES—Per 100—TO DEALERS ONLY

	CHICAGO Jan. 27	TWIN CITIES Jan. 27	PHILA. Jan. 27	BOSTON Jan. 30
ROSES				
Am. Beauty, Fancy and Special...	35.00 to 40.00	40.00 to 50.00	50.00 to 60.00	40.00 to 50.00
" " Extra	25.00 to 30.00	35.00 to 40.00	30.00 to 40.00	20.00 to 30.00
" " No. 1	10.00 to 15.00	20.00 to 30.00	15.00 to 25.00	10.00 to 15.00
" " Lower grades	6.00 to 8.00	10.00 to 15.00	6.00 to 12.00	6.00 to 8.00
Bride, "Maid, Fancy & Special	8.00 to 10.00	10.00 to 12.00	12.00 to 15.00	10.00 to 12.00
" " Extra	6.00 to 7.00	8.00 to	8.00 to 10.00	6.00 to 8.00
" " Lower grades	3.00 to 5.00	4.00 to 6.00	4.00 to 6.00	2.00 to 4.00
Killarney, Richmond, Fan & Sp.	8.00 to 10.00	8.00 to 12.00	12.00 to 20.00	12.00 to 25.00
" " Lower grades	3.00 to 5.00	4.00 to 6.00	5.00 to 10.00	4.00 to 6.00
Chapenay, Wellesley, Fan, & Sp.	8.00 to 10.00	5.00 to 12.00	12.00 to 15.00	12.00 to 15.00
" " Lower grades	3.00 to 6.00	4.00 to 6.00	4.00 to 8.00	6.00 to 8.00
Golden Gate Ivory	8.00 to 10.00	6.00 to 12.00	4.00 to 10.00	6.00 to 8.00
CARNATIONS				
Fancy and Novelties	4.00 to 5.00	4.00 to 5.00	3.00 to 6.00	1.00 to 3.00
Ordinary	4.00 to 3.00	3.00 to 4.00	1.50 to 2.50	1.00 to 2.00
MISCELLANEOUS				
Viole s75 to 1.00	1.00 to 1.25	.25 to 1.00	.50 to .75
Cattleyas	50.00 to 60.00	50.00 to 60.00	50.00 to 60.00	40.00 to 50.00
Cyrtipediums	12.00 to 15.00	12.00 to 16.00	12.50 to 15.00	12.00 to 12.00
Lilies	12.00 to 15.00	15.00 to 18.00	12.00 to 15.00	12.00 to 15.00
Lily of the Valley	3.00 to 4.00	3.00 to 5.00	2.00 to 4.00	1.00 to 2.00
Rom n Hy, Paper White Nar.	3.00 to 4.00	3.00 to 4.00	2.00 to 3.00	1.00 to 2.00
Stevia	1.00 to 2.00 to	2.00 to 3.00	1.00 to 2.00
Mignonette	3.00 to 5.00	3.00 to 6.00	2.00 to 5.00	3.00 to 6.00
Adiantum75 to 1.00	1.00 to 1.50	1.00 to 1.50	1.00 to 1.50
Whitmaoii Froods to to	2.00 to 3.00	1.00 to 1.50
Smilax	12.00 to 15.00	14.00 to 18.00	15.00 to	12.00 to 16.00
Asparagus Plumosus, strings	35.00 to 50.00	40.00 to 60.00	50.00 to to 50.00
" " & Spren. (100 bchs.)	35.00 to 50.00	40.00 to 60.00	35.00 to 50.00 to 50.00

THE FLORISTS' SUPPLY HOUSE OF AMERICA

Without a rival in knowledge of the requirements of the trade and the ability to supply them. Our New Illustrated Catalogue, recognized as a work of art unprecedented in its line for variety, novelty and completeness, tells the story fully, and if you have not yet sent for it, do so now.

'TIS FREE TO EVERYBODY IN THE TRADE

H. BAYERSDORFER & CO., 1129 Arch St., Philadelphia, Pa.

FLOWER MARKET REPORTS

BOSTON Market conditions have not improved over last week. With an abundance of stock all along the line and but little trading, prices have fallen considerably. Carnations are a glut in the market, while violets, roses, sweet peas and jonquils are doing but fairly well.

A mixture of all kinds of weather being on the past week made the supply heavy one day and short the next, which kept the wholesalers guessing. Teas were scarce, especially the short grades, which were in heavy demand as floral work was plentiful, and a good portion of other stock such as lily of the valley, sweet peas, tulips, freesia, and lilies had to be substituted. On Richmonds and selected teas prices held firm and on some lines went up a notch, and the only report received from growers was "off crop, best can do." Carnations in light colors were well cleaned up, but a good many Lawsons and dark colors of ordinary quality were carried over to Monday. Violets were in good supply but a little weak as to prices, the quality being good. Spring flowers are coming in more plentifully; daffodils and yellow tulips sold well; white Lorraine with short stems seemed to remain. Southern smilax is in better demand; other greens are quite abundant.

DETROIT Business the past week has been very satisfactory. Bulbous stock of all descriptions is coming in in good quality and selling at good prices.

INDIANAPOLIS There has been a decided improvement in the movement of all kinds of cut flowers the past week which means a fairly clean market. There is nothing rushing but just enough demand to take care of the supply. Good Beauties and teas are not over-plentiful, the top grades bringing good prices. Bulbous stock lilac, violets and sweet peas have been moving better than before, Callas and Harrisii are sold on sight. Roman hyacinths are about the only thing that is in over-supply. Freesia is now coming in in good quantities. Orchids of many varieties help to make attractive retail windows. Not a florist in the larger cities whose trade is worthy of the name is without the orchid now. Trade in pot plants of all kinds is rather slow. There is quite a trade in green goods, galax and leucothoe being used in large quantities.

PHILADELPHIA The sluggish conditions we have experienced for some time still continue here. Trading is half-hearted all along the line. Still, we presume it is no worse than elsewhere. One New York wholesaler who honored us with a visit the other day remarked that things in the metropolis were such that he run away to Philadelphia for a short spell to escape them. There is nothing new to report in the rose or carnation markets. Beauty roses still continue of good quality and ample supply for the demand. Bride is in excellent demand and one of the most satisfactory subjects at present. Killarney is also

good. In carnations the Beacon stands out conspicuous and brings top price. Lily of the valley has recovered a little and is now moving rather better. Sweet peas sell fairly well but prices are still too low for profit. Trumpet daffodils from nearby sources are well received and prices are fair, all things considered. Crops of paper whites have shortened up and these are now in healthy demand at fair prices. Tulips have commenced. La Reine and Couronne d'or principally, so far. Lilac, mignonette, Easter lilies continue good, and move out reasonably well.

The flower market **TWIN CITIES** has been very steady this last week. Carnations, violets, paper whites, tulips and daffodils are plentiful and good. Roses, with the exception of American Beauties, are getting short in both Minneapolis and St. Paul.

PHILADELPHIA NOTES.

"Indoor Culture of Carnations" will be the special subject up for discussion before the Florists' Club of Philadelphia the first Tuesday of February. Edmond A. Harvey, Brandywine Summit, will be the orator.

Arthur Niesseon, of the Leo Niessen Co., is inclined to agree with many other experts that Bridesmaid rose has reached "the old-maid" stage of its existence, and that we will have to look for new blood for the future. He thinks also that such roses as Killarney are in a class by themselves, and not to be considered as competitors for "the new Bridesmaid" honors.

The impression prevails with many that our propagating method is largely responsible for the running out of our forcing roses. P. J. Lynch recommends instead the use of summer propagated, winter rested, own-root stock grown from roses that have never been forced. If this is done he is positive he will hear less of our good old roses running out. Paste that pointer in your hat. It is from a man who has made a life study of the subject.

Ernst F. Hoehl, late of Madison, N. J., now occupies the Bunting place at Fifty-eighth and Elmwood avenue. He is making a specialty of sweet peas and carnations.

A handsomely illustrated circular of the new rose Mrs. Jardine is being sent out by the Pennock-Meehan Co.

Early chrysanthemums are being featured by the Michell Co. this spring. Golden Glow, Lynwood Hall, Pacific Supreme and White Cloud are the gems of a collection embracing some thirty varieties. A colored plate of this flower occupies the front cover of their catalogue.

The Philadelphia delegation to the carnation convention included among others Dennis T. Connor, William P. Craig, Edwin J. Faneourt, Edward A. Stroud, W. Beattie, S. S. Skidelski, Robert Kirt, Samuel S. Pennock, J. Girvin and Wm. Kleinboinz.

The KERVAN CO. 113 W. 28th ST. New York

WHOLESALE DEALERS
Fresh cut Palmetto & Cycas Palm Leaves, Galax, Leucothoe, Ferns and Mosses. All Decorating Evergreen.

Bargains in Plants

If you want bargains in plants watch the ads appearing

Exclusively in Horticulture

The Philadelphia Plant Exchange is just what it's name implies:—

BARGAINS to YOU!

We hunt for them, and our guarantee goes with every one! Personal inspection and guarantee.

This week's Bargain offers

LOT No.		EAch
101	300 Kentia Forsteriana, 6 in.,	\$1.50
102	200 " " 7 in.,	2.00

The above two lots Nos. 101 and 102 are **made up plants**, clean and well furnished. A decided bargain at the price.

CARNATION CUTTINGS

LOT No.		100	1000
103	4000 Boston Market	\$2.00	\$18.00
104	3000 Enchantress	2.50	20.00
105	3000 Joost	2.00	17.00
106	3000 Marion	2.00	17.00

FERNS AND RUBBERS

LOT No.		100
107	1000 Mixed Ferns, 3 in., 12 vars.	\$7.00
108	400 Whitman, 4 in.	25.00
109	500 Todaeoides, 2½ in.	20.00
110	500 4 in. Rubbers, fine plants	25.00
111	500 Rubber Cuttings, (well rooted)	15.00

Send us your orders or inquiries for anything you want. The above is only a sample of the immense stocks of fine plants behind our organization.

Also if you have anything to sell, let us know. If your stock is all right, after our personal inspection, and such as we know will please our customers, we will handle it for you and find a market, but it must be first class and a bargain. Our only charge is 10% on sale price.

Don't Grow Crops there's No Demand For

Write us first. We cannot handle anything unless it is first class in every way. That's the meaning of our guarantee to customers.

Address all orders to

Philadelphia Plant Exchange
839 Market Street
PHILADELPHIA

Keystone Phone 5248 0 Main Bell Phone 5639 Walnut

JOHN YOUNG
WHOLESALE FLORIST
 Finest American Beauties and Carnations
51 West 28 St. - NEW YORK

FORD BROTHERS
 48 West 28th Street, NEW YORK
FINE ROSES FANCY CARNATIONS
 A Full Line of All CUT FLOWERS
 Telephone, 3870 or 3871 Madison Square

H. E. FROMENT,
 Wholesale Commission Florist,
 Choice Cut Flowers,
 57 West 28th St., :: NEW YORK.
 Telephones: 2200, 2201, Madison Square.

The Reliable Commission House
 Richmond Roses and Rich Flowers of all varieties
JOS. S. FENRICH
 110 W. 28th Street, New York
 Tel. 324-325 Madison Square

Established 1891 BUY FROM SHIP TO TRY **ME**
ALFRED H. LANGJAHR
 All Choice Cut Flowers In Season
 55 West 28th St., New York
 Telephone 3924 Madison Square.

JOHN I. RAYNOR
Wholesale Commission Florist SELLING AGENT FOR LARGEST GROWERS
 A full line of Choice Cut Flower stock for all purposes. Comprises every variety grown for New York market, at current prices
 TEL. 1998 MADISON SQUARE 49 W. 28 St., New York City

Walter F. Sheridan
 Wholesale Commission Dealer in
CHOICE CUT FLOWERS
 39 West 28th Street, New York
 Telephone: 3532-3533 Madison Square

HEADQUARTERS FOR NOVELTIES
ORCHIDS A SPECIALTY
 THE HIGHEST GRADE OF **VALLEY** ALWAYS ON HAND
 GARDENIAS, DAISIES, ROSES AND CARNATIONS
 Telephone 759 Madison Sq.
JAMES McMANUS, 42 W. 28th St., New York

PHILIP F. KESSLER 55 & 57 W. 26th St., New York City
 Commission Dealer, Wholesale Buyer and Seller of
 Open from 5 a.m. to 6 p.m. Sunday till 10 a.m.
 Tel., 5243 and 2921 Madison Sq. Res., 345 J., Newtown, N.Y.
CUT FLOWERS
 Finest Lilies in the Market Every Day in the Year.

WHOLESALE COMMISSION FLORIST
J. K. ALLEN 106 W. 28 ST. NEW YORK
 Telephone 167 Madison Sq.
 OPEN 6 A.M. DAILY
 We have a good regular outlet for seasonable flowers

NEW YORK QUOTATIONS PER 100—TO DEALERS ONLY

	Last Half of Week ending Jan. 25 1903	First Half of Week beginning Jan. 27 1903	Last Half of Week ending Jan. 25 1903	First Half of Week beginning Jan. 27 1903
Roses				
Am. Beauty, fan and sp.	20.00 to 50.00	30.00 to 60.00	25.00 to 60.00	25.00 to 60.00
" extra	15.00 to 20.00	15.00 to 20.00	12.00 to 15.00	8.00 to 12.00
" No. 1	10.00 to 15.00	12.00 to 15.00	8.00 to 10.00	8.00 to 10.00
" Lower grades	1.00 to 5.00	1.00 to 2.00	1.00 to 2.00	1.00 to 2.00
Bride, 'Maid, fan and sp.	10.00 to 12.00	8.00 to 12.00	8.00 to 10.00	8.00 to 10.00
" " extra	7.00 to 8.00	5.00 to 6.00	5.00 to 6.00	5.00 to 6.00
" " lwr. grds.	1.00 to 6.00	1.00 to 3.00	1.00 to 3.00	1.00 to 3.00
Killbuck, Richmond, tancy & spec lower grades.	1.00 to 15.00	10.00 to 15.00	2.00 to 4.00	2.00 to 5.00
" " lower grades.	2.00 to 6.00	2.00 to 4.00	2.00 to 4.00	2.00 to 5.00
Chatenay, Wellesley, fan. and spec. lower grades.	6.00 to 8.00	8.00 to 10.00	1.00 to 3.00	1.00 to 1.50
" " lower grades.	2.00 to 4.00	1.00 to 3.00	1.00 to 1.50	1.00 to 1.50
Golden Gate, Ivory.	2.00 to 8.00	1.00 to 6.00	8.00 to 10.00	8.00 to 10.00
Carnations, Fancy and Novelties. .	3.00 to 5.00	2.00 to 4.00	25.00 to 50.00	25.00 to 40.00
" Ordinary	1.00 to 2.00	1.00 to 2.00	10.00 to 15.00	10.00 to 15.00
Violets30 to .60	.40 to .60	10.00 to 15.00	10.00 to 15.00
Cattleyas				
Cypripediums				
Lilies				
Lily of the Valley				
Gardenias				
Roman Hy., Paper White Nar. .				
Stevia				
Mignunette				
Adiantum				
Smilax				
Asparagus Plumosus, strigs. .				
 " " & Spreu. (too bchs.)				

B. S. SLINN, Jr.
 WHOLESALE FLORIST
 55 & 57 W. 26th St., New York City
 Tel., 3864 Madison Sq. Shipping Orders Solicited.
VIOLETS **Roses and**
 Carnations

Edward C. Horan
Wholesale Florist
 55 WEST 28th ST.
 Tel. 1462 1463 Madison Square New York

TRAENDLY & SCHENCK
WHOLESALE FLORISTS
 Furnish best stock at fair prices all the year round Send for quotations on fall orders
 Tel. 798.799 Madison Sq. 44 West 28th Street, New York City

Alexander J. Guttman
THE WHOLESALE FLORIST OF NEW YORK
 43 WEST 28th STREET
 PHONES. 1664-1665 MADISON SQUARE
ENOUGH SAID



HARDY CUT FERNS

Sphagnum Moss, Extra Large Bales, per bale, \$1.25. Fancy and Dagger Ferns our specialty. A trial order will convince you that we ship only first-class stock. Headquarters for Florists' supplies and wire work. All cut flowers in season. **BOXWOOD**, per bunch 35c, 50 lbs. \$7.50.

MICHIGAN CUT FLOWER EXCHANGE, INC., All 'phone connections 38-40 Broadway, Detroit, Mich.

FANCY and DAGGER
Extrafine, \$1.50 per 1000. Bronze and Green Galax, \$1.25 per 1000. Leucothoe Sprays, \$1.00 per 100, \$7.50 per 1000.

WHOLESALE FLORISTS
54 West 28th St.
NEW YORK
Telephone 3559 Madison Sq.

A. L. YOUNG & CO.

RECEIVERS & SHIPPERS OF CUT FLOWERS.
CONSIGNMENTS SOLICITED.

Headquarters in Western New York
FOR
ROSES, CARNATIONS
And all kinds of Seasonable Flowers
Wm. F. Kasting Co.
Wholesale Commission Florist, also Dealer in Florists' Supplies and Wire Designs.
383-87 ELLICOTT ST. BUFFALO, N. Y.
Give us a trial. We can please you.

FRANK S. HICKS & CO.
Wholesale Florists.
Open Now for Consignments of Cut Flowers.
52 West 28th Street, - New York City
Tel. 2920 Mad. Sq.

FRANK MILLANG
Wholesale Florist
Telegraphic Orders Filled and Delivered.
55-57 West 26th St., New York City.

Charles Millang
50 West 29th St., New York City
Cut Flowers on Commission
A Reliable Place to Consign to or order from
Telephone: 3860-3871 Madison Square

A. MOLTZ
Will purchase flowers on order in N. Y. market and ship carefully at prevailing wholesale prices. Address
55-57 West 26th Street, New York City

Best Flowers
IN THE
BOSTON MARKET
N. F. McCarthy & Co.
84 Hawley St., BOSTON, MASS.
Send for Prices

HENRY M. ROBINSON & CO.
WHOLESALE COMMISSION FLORISTS
Finest Grades of Roses, Carnations, Chrysanthemums, Lily of the Valley, Violets, etc.
15 Province St. & 9 Chapman Pl., Boston, Mass.
See our Fern ad.

WHOLESALE FLOWER MARKETS.— PER 100. TO DEALERS ONLY.

	CINCINNATI Jan. 28	DETROIT Jan. 26	BUFFALO Jan. 27	PITTSBURG Jan. 27
ROSES				
Am. Beauty, Fan. and Sp.	30.00 to 40.00	50.00 to 65.00	40.00 to 50.00	30.00 to 40.00
" Extra	20.00 to 25.00	25.00 to 30.00	20.00 to 30.00	20.00 to 25.00
" No. 1	10.00 to 15.00	20.00 to 25.00	10.00 to 15.00	10.00 to 15.00
" Lower grades	4.00 to 8.00	0.00 to 15.00	5.00 to 10.00	4.00 to 5.00
Bride, 'Maid, F. & S.	4.00 to 10.00	10.00 to 12.00	10.00 to 15.00	10.00 to 12.00
" Extra	6.00 to 8.00	8.00 to 10.00	8.00 to 10.00	8.00 to 10.00
" Low grades	4.00 to 5.00	5.00 to 6.00	4.00 to 5.00	4.00 to 5.00
Killarney, Richmond, Fan. & Sp.	10.00 to 12.00	8.00 to 10.00	10.00 to 15.00	12.00 to 15.00
" Lower grades	6.00 to 8.00	6.00 to 8.00	6.00 to 10.00	8.00 to 10.00
Chateaux, Wellesley, Fan. & Sp.	8.00 to 10.00	8.00 to 10.00	12.00 to 15.00	10.00 to 12.00
" Lower grades	6.00 to 8.00	6.00 to 8.00	6.00 to 10.00	6.00 to 8.00
Golden Gate, Ivory	6.00 to 8.00	8.00 to 10.00	4.00 to 10.00	6.00 to 8.00
CARNATIONS				
Fancy and Novelties	4.00 to 5.00	4.00 to 5.00	4.00 to 5.00	3.00 to 4.00
Ordinary	2.00 to 3.00	2.00 to 3.00	2.00 to 3.00	2.00 to 3.00
MISCELLANEOUS				
Violets	50 to 75	1.00 to 1.50	1.00 to 1.25	1.50 to 2.00
Cattleyas	30.00 to 60.00	34.00 to 50.00	40.00 to 50.00	30.00 to 40.00
Cypripediums	12.00 to 15.00	8.00 to 10.00	10.00 to 15.00	10.00 to 15.00
Lilies	12.00 to 15.00	20.00 to 25.00	5.00 to 15.00	10.00 to 15.00
Lily of the Valley	3.00 to 4.00	3.00 to 4.00	3.00 to 4.00	3.00 to 4.00
Roman Hy., Paper White Nar.	3.00 to 4.00	3.00 to 4.00	2.00 to 3.00	1.00 to 2.00
Stevia	1.00 to 1.00	2.00 to 3.00	1.00 to 1.25	1.00 to 1.00
Mignonette	1.00 to 1.00	8.00 to 10.00	3.00 to 6.00	2.00 to 4.00
Adiantum	1.00 to 1.00	1.00 to 2.00	1.50 to 2.00	1.00 to 1.20
Whitmanii Fronds	1.00 to 1.00	1.00 to 1.00	1.00 to 1.00	1.00 to 1.00
Smilax	10.00 to 12.50	15.00 to 15.00	15.00 to 15.00	10.00 to 15.00
Asparagus Plumosus, strings	40.00 to 50.00	50.00 to 75.00	50.00 to 60.00	30.00 to 50.00
" " & Spreo (100 bchs.)	25.00 to 35.00	30.00 to 40.00	25.00 to 30.00	30.00 to 40.00

SAMUEL A. WOODROW
WHOLESALE PLANTSMAN
Palms, Large and Small Ferns, etc.
53 West 30th Street, NEW YORK
Telephone 2083 Madison

WILLIAM H. KUEBLER
Brooklyn's Foremost and Best
WHOLESALE COMMISSION HOUSE
A First Class Market for all CUT FLOWERS
28 Willoughby St., Brooklyn, N. Y.
Tel. 4591 Maio

CLEARY'S HORTICULTURAL CO.
Management AMBROSE T. CLEARY
Wholesale Contracting, Jobbing, Auction
HORTICULTURAL PRODUCTS
of every description.
Consignments Received. Surplus Stock Converted.
62 Vesey St., NEW YORK

Moore, Hentz & Nash,
Wholesale Commission Florists,
55 and 57 West 26th Street,
Telephone No. 756
Madison Square. **New York.**

H. C. BERNING
Wholesale Florist
1402 Pine Street, ST. LOUIS, MO.

Alex Mann, Jr. Co. Inc.
Wholesale Dealer in
Florists' Supplies and Cut Flowers
White Doves, \$9.00 per doz.
Galax Leaves.
1125 Polk Street, San Francisco, Cal.

J. B. Murdoch & Co.
Wholesale Florists
FLORISTS' SUPPLIES
714 Penn Ave., PITTSBURG, PA.
Long Distance 'Phone 1435 Court.

REED & KELLER
122 West 25th St., New York
Florists' Supplies
We manufacture all our
Metal Designs, Baskets, Wire Work & Novelties
and are dealers in
Glassware Decorative Greens and Florists' Requisites.

Buyer's Directory and Ready Reference Guide

Advertisements under this head, one cent a word. Initials count as words.

Regular advertisers in this issue are also listed under this classification without charge. Reference to List of Advertisers will indicate the respective pages.

Buyers failing to find what they want in this list will confer a favor by writing us and we will try to put them in communication with reliable dealers.

ACCOUNTANT

R. J. Dysart, 28 State St., Boston.
For page see List of Advertisers.

ALTERNANTHERAS

Red Alternantheras at 40 cents per 100.
C. W. Moeckel, 17 Summer St., Fitchburg, Mass.

AQUARIUMS

Aquarium plants the year round. Wholesale and retail. Send for price list Schmid's Emporium of Pets, 712 12th Street, Washington, D. C.

ARAUCARIAS

Godfrey Aschmann, 1012 Ontario St., Philadelphia, Pa.
For page see List of Advertisers.

ARTIFICIAL CALYX

Maxfield & Dimond, Warren, R. I.
For page see List of Advertisers.

ASPARAGUS

Asparagus Sprengeri, field grown, \$4.00 and \$6.00 per 100. C. Winterlich, Defiance, Ohio.

Asparagus Plumosa, 2 in. pots. Fine plants. \$2.50 per 100; \$20.00 per 1000. Cash with order or good reference. Erie Floral Co., Erie, Pa.; or Wm. F. Kasting Co., 385 Ellcott St., Buffalo, N. Y.

AUCTION SALES

Cleary's Horticultural Co., 62 Vesey St., New York.
Horticultural Products of Every Description.
For page see List of Advertisers.

Sales every Tuesday and Friday. If you cannot attend send bids and shipping instructions. Catalogues on application. N. F. McCarthy & Co., 84 Hawley St., Boston.

AZALEAS

A. Leuthy & Co., Perkins St. Nurseries, Roslindale, Mass.
For page see List of Advertisers.

W. W. Edgar Co., Waverley, Mass.
For page see List of Advertisers.

August Rolker & Sons, New York, 31 Barclay St., or P. O. Box 752.
For page see List of Advertisers.

Boblink & Atkins, Rutherford, N. J.
For page see List of Advertisers.

BAMBOO CANES

Stump & Walter Co., 50 Barclay St., New York.
For page see List of Advertisers.

Yokohama Nursery Co., 31 Barclay Street, New York.
For page see List of Advertisers.

BAY TREES.

Specimens and pairs, all sizes. Send for prices. N. F. McCarthy & Co., 84 Hawley St., Boston.

Bsy Trees and Box Trees, standards and pyramids. All sizes. Price list on application. J. Roehrs Co., Rutherford, N. J.

BEGONIAS

Wm. Elliott & Sons, 201 Fulton St., New York.
For page see List of Advertisers.

BOILERS

BOILERS. "Burnham" Boilers made for greenhouse heating. Lord & Burnham, 1133 Broadway, N. Y.

BOXWOOD

A. Leuthy & Co., Perkins St. Nurseries, Roslindale, Mass.
For page see List of Advertisers.

Henry M. Robinson & Co., 15 Province St., Boston.
For page see List of Advertisers.

BUILDING MATERIAL

BUILDING MATERIAL of all description for All Cypress, Scam-iron, Iron Frame or Truss Houses. Hot Red Sash and Frames. Lord & Burnham Co., 1133 Broadway, N. Y.

BULBS AND TUBERS

Joseph Breck & Sons, 47-54 N. Market St., Boston.
For page see List of Advertisers.

J. M. Thornburn & Co., 33 Barclay St., New York.
For page see List of Advertisers.

A. T. Boddington, 342 W. 14th St., N. Y.
For page see List of Advertisers.

Rickards Bros., 37 East 19th St., New York.
For page see List of Advertisers.

H. F. Michell Co., Philadelphia.
For page see List of Advertisers.

H. E. Flske Seed Co., Faneull Hall Sq., Boston.
For page see List of Advertisers.

James Vick's Sons, Rochester, N. Y.
Fall Bulbs.
For page see List of Advertisers.

D. Rusconi, 123 W. Sixth St., Cincinnati, O.
Lilium Auratum, Roseum, Multiflorum.
For page see List of Advertisers.

Aug. Rolker & Sons, 31 Barclay St., New York.
Seasonable Import Plants and Bulbs.
For page see List of Advertisers.

John Scheepers & Co., 4 and 6 Old Slip, New York.
Lily of the Valley Excellenta.
For page see List of Advertisers.

K. Velthuis, Hillegom, Holland.
Represented by Felix Bosch, 260 Clarendon St., Boston.
Bulbs French and Dutch.
For page see List of Advertisers.

Dwarf Pearl tuberose, 50,000 No. 2, very fine bulbs, 4 in. in circumference. Write for prices. T. V. Rivenbark, Wallace, N. C.

25 Lily of Valley, postpaid, 50 cts; 200 Duntap, Warfield Strawberry plants, postpaid, \$1.35. Catalogue free. Alva Y. Cathcart, Bristol, Indiana.

CANNAS

The Conard & Jones Co., West Grove, Pa.
For page see List of Advertisers.

Good robust stock, dark-leaved, at \$1.50 per 100; large clumps Burlington, White Berat and Cimchar, at \$2.00 per 100; Pennsylvania, at \$2.50 per 100. C. W. Moeckel, 17 Summer St., Fitchburg, Mass.

CARNATIONS

Field Grown

The H. Weber & Sons Co., Oakland, Md.
Seedling Carnation Toreador.
For page see List of Advertisers.

CARNATIONS—Continued

Rooted Cuttings

F. Dorner & Sons Co., Lafayette, Ind.
For page see List of Advertisers.

S. S. Skidelsky, 1741 N. 18th St., Philadelphia.
For page see List of Advertisers.

Chicago Carnation Co., Joliet, Ill.
For page see List of Advertisers.

F. R. Pierson Co., Tarrytown, N. Y.
Windsor and White Enchantress Rooted Cuttings.
For page see List of Advertisers.

H. A. Jahn, New Bedford, Mass.
Carnation Lloyd.
For page see List of Advertisers.

Guttman & Weber, 43 W. 25th St., New York.
For page see List of Advertisers.

F. H. Kimberly, 631 Townsend Ave., New Haven, Conn.
For page see List of Advertisers.

John E. Haines, Bethlehem, Pa.
Carnations Imperial and Pink Imperial.
For page see List of Advertisers.

Welch Bros., 226 Devonshire St., Boston.
Carnation White Fair Maid.
For page see List of Advertisers.

A. N. Pierson, Cromwell, Ct.
Carnation Winsor.
For page see List of Advertisers.

H. N. Hoffman, Elmira, N. Y.

Peter Fisher, Edis, Mass.
Carnation Beacon.

H. W. Field, Northampton, Mass.
Carnation President Seelye.

R. Witterstaetter, Sta. F., Cincinnati, O.
Carnation Afterglow.

Jacob Schulz, 614 4th Av., Louisville, Ky.
White Enchantress Rooted Cuttings.

CHRYSANTHEMUMS

W. W. Edgar Co., Waverley, Mass.
For page see List of Advertisers.

Charles H. Totty, Madison, N. J.

CONIFERS

John Waterer & Sons, Ltd., American Nursery, Bagshot, Eng.
For page see List of Advertisers.

Write for prices on all choice ornamental conifers. N. F. McCarthy & Co., 84 Hawley St., Boston, Mass.

CUT FLOWER BOXES.

Edwards Folding Box Co., Philadelphia.
For page see List of Advertisers.

Getmore Box Factory, Inc., Belleville, Ala.
Light Wood Boxes.

Folding cut flower boxes, the best made. Write for list. Holton & Hunkel Co., Milwaukee, Wis.

DAHLIAS

David Herbert & Son, Atco, N. J.
For page see List of Advertisers.

J. L. Moore, Northboro, Mass.
For page see List of Advertisers.

R. & J. Farquhar Co., 6 and 7 S. Market St., Boston.
Dahlia Chas. Lanier.

For List of Advertisers See Page 156

DECORATIVE PLANTS

- A. Leuthy & Co., Roslindale, Mass. For page see List of Advertisers.
- Julius Roehrs, Rutherford, N. J. For page see List of Advertisers.
- Anton Schultbels, College Point, N. Y. For page see List of Advertisers.
- Philadelphia Plant Exchange, 539 Market St., Philadelphia, Pa. For page see List of Advertisers.

ELECTRIC CIRCULATOR

The Castle Co., 170 Summer St., Boston.

FERNS

- A. Leuthy & Co., Roslindale, Mass. For page see List of Advertisers.
- H. H. Barrows & Son, Whitman, Mass. Nephrolepis Whitmanii. For page see List of Advertisers.
- Godfrey Aschmann, 1012 Ontario St., Philadelphia, Pa. For page see List of Advertisers.
- John Scott, Brooklyn, N. Y. For page see List of Advertisers.
- Baur Floral Co., Erie, Pa. For page see List of Advertisers.
- Henry A. Dreer, Philadelphia, Pa. Ferns for Dishes. For page see List of Advertisers.
- T. J. Ray & Co., Elk Park, N. C.
- Whitman ferns, 9 in., \$1.00; 8 in., 80c. Hy. Ernst & Son, Washington, Mo.

FERTILIZERS

- Pulverized Manure Co., 31 Union Stock Yards, Chicago, Ill.
- Wizard Brand Cattle Manure. For page see List of Advertisers.
- Thos. J. Grey & Co., 32 and 33 South Market St., Boston. High-Grade Scotch Soot. For page see List of Advertisers.

FLORAL PHOTOGRAPHS

Floral Photographs. Foley's 226-228 1-2 Bowery, New York.

FLORISTS' LETTERS.

- Boston Florist Letter Co., 63 Pearl St., Boston, Mass. For page see List of Advertisers.
- Koral Mfg. Co., 26 Hawley St., Boston. For page see List of Advertisers.

FLORISTS SUPPLIES

- H. M. Robinson & Co., 15 Province St. and 9 Chapman Pl., Boston, Mass. For page see List of Advertisers.
- The Kervan Co., 113 W. 28th St., N. Y. Decorative Evergreens. For page see List of Advertisers.
- Reed & Keller, 122 W. 25th St., New York. For page see List of Advertisers.
- J. B. Murdoch & Co., 545 Liberty St., Pittsburg, Pa. For page see List of Advertisers.
- H. Bayersdorfer & Co., 1129 Arch St., Philadelphia. For page see List of Advertisers.
- Alex. Mann, Jr., Co., 1125 Polk St., San Francisco, Calif. For page see List of Advertisers.

FLOWERS BY TELEGRAPH

- Park Floral Co., Denver, Colo. For page see List of Advertisers.
- George H. Cooke, Washington, D. C. For page see List of Advertisers.
- Gude Bros. Co., 1214 F St., Washington, D. C. For page see List of Advertisers.
- Atlanta Floral Co., Atlanta, Ga. For page see List of Advertisers.
- P. J. & J. E. Hauswirth, 232 Michigan Ave., Chicago. For page see List of Advertisers.

FLOWERS BY TELEGRAPH - Continued

- William J. Smyth, Michigan Ave. and 31st St., Chicago. For page see List of Advertisers.
- Jacob Schulz, 644 4th Ave., Louisville, Ky. For page see List of Advertisers.
- Thos. F. Galvin, 124 Tremont St., Boston. For page see List of Advertisers.
- Julius A. Zinn, 2 Beacon St., Boston. For page see List of Advertisers.
- Houghton & Clark, 396 Boylston St., Boston. For page see List of Advertisers.
- Sidney Hoffman, 59-61 Massachusetts Ave., Boston. For page see List of Advertisers.
- J. Brettmayer's Sons, Miami and Gratiot Aves., Detroit, Mich. For page see List of Advertisers.
- Samuel Murray, 1017 Broadway, Kansas City, Mo. For page see List of Advertisers.
- Wm. L. Rock Flower Co., 1116 Walnut St., Kansas City, Mo. For page see List of Advertisers.
- Fred C. Weber, 4326-28 Olive St., St. Louis, Mo. For page see List of Advertisers.
- H. G. Eyres, 11 N. Pearl St., Albany, N.Y. For page see List of Advertisers.
- David Clarke's Sons, 2159-2141 Broadway, New York. For page see List of Advertisers.
- W. H. Donohoe, 17 E. 28th St., New York. For page see List of Advertisers.
- Alex. McConnell, New York. For page see List of Advertisers.
- Robert G. Wilson, Fulton St. & Greene Av., Brooklyn, N. Y. For page see List of Advertisers.
- Thos. Young, Jr., 41 W. 28th St., N. Y. For page see List of Advertisers.
- Young & Nugent, 42 W. 28th St., N. Y. For page see List of Advertisers.

FLOWER POTS

- W. H. Ernest, 25th and M Sta., Washington, D. C. For page see List of Advertisers.
- A. H. Hews & Co., Cambridge, Mass. For page see List of Advertisers.
- Hilfinger Bros., Ft. Edward, N. Y. For page see List of Advertisers.

FORCING ROOTS

Bobblin & Atkins, Rutherford, N. J. For page see List of Advertisers.

GALAX

- Michigan Cut Flower Co., 38 and 40 Broadway, Detroit, Mich. For page see List of Advertisers.
- Fluist green and bronze Galax in any quantity at lowest figures. N. F. McCarthy, 84 Hawley St., Boston.
- T. J. Ray & Co., Elk Park, N. C.

GERANIUMS

- R. Vincent Jr. & Sons Co., White Marsh, Md. New and Standard Varieties. For page see List of Advertisers.
- S. A. Nutt, Rooted Cuttings, at \$1.25 per 100. C. W. Moeckel, 17 Summer St., Fitchburg, Mass.

GLADIOLI

- Arthur Cowee, Meadowvale Farm, Berlin, New York. For page see List of Advertisers.
- J. L. Moore, Northboro, Mass. For page see List of Advertisers.
- Gladioli. Write for leaflet. B. Hammond Tracy, Cedar Acres, Wenham, Mass.
- Gladioli Colvill Alba, \$1.00 per 100; \$7.50 per 1000. Gladioli Rosea, \$1.25 per 100; \$9.00 per 1000. America, light pink. Immense flower, \$1.00 per doz.; \$7.50 per 100. Cushman Gladiolus Co., Sylvania, O.

GLASS

- Boston Plate & Window Glass Co., Boston. For page see List of Advertisers.
- Standard Plate Glass Co., 26-30 Sudbury St., Boston. For page see List of Advertisers.
- Foley Mfg. Co., between Western Ave. and 26th St., Chicago, Ill.
- GLASS, High Grade, Double Thick Greenhouse Glass. Lord & Burnham, 1133 Broadway, N. Y.

GLAZING POINT

- H. A. Dreer, Philadelphia, Pa. For page see List of Advertisers.
- GLAZING POINTS, Lord & Burnham Special Glazing Nails (Points). Lord & Burnham, 1133 Broadway, N. Y.

GREENHOUSE BUILDING MATERIAL.

- Lord & Burnham Co., 1133 Broadway, New York. For page see List of Advertisers.
- Pierson U-Bar Co., 1 Madison Sq., N. Y. For page see List of Advertisers.
- Hitchings & Co., 1170 Broadway, N. Y. For page see List of Advertisers.
- A. T. Stearns Lumber Co., Neponset, Boston. For page see List of Advertisers.
- King Construction Co., N. Tonawanda, New York. For page see List of Advertisers.
- J. C. Moninger Co., 117 East Blackhawk St., Chicago, Ill. For page see List of Advertisers.
- Foley Mfg. Co., between Western Ave. and 26th St., Chicago, Ill. For page see List of Advertisers.
- I. Cassidy, Summer Ave. and Erie R. R., Newark, N. J. For page see List of Advertisers.
- W. H. Lutton, Jersey City, N. J. For page see List of Advertisers.
- Metropolitan Material Co., 1398-1408 Metropolitan Ave., Brooklyn, N. Y. For page see List of Advertisers.
- S. Jacobs & Sons, 1365-79 Flushing Ave., Brooklyn, N. Y.

GREENHOUSE CONSTRUCTION

- GREENHOUSE CONSTRUCTION, Semi-Iron Greenhouse, New Truss Houses and Iron Frame Houses. Lord & Burnham, 1133 Broadway, N. Y.
- J. A. Payne, 260-274 Culver Ave., Jersey City, N. J. For page see List of Advertisers.

- I. Cassidy, Summer Ave. and Erie R. R., Newark, N. J. For page see List of Advertisers.

Foley Mfg. Co., between Western Ave. and 26th St., Chicago, Ill.

W. H. Lutton, Jersey City, N. J. For page see List of Advertisers.

GREENHOUSE HOSE

Mineralized Rubber Co., 18 Cliff St., N. Y. For page see List of Advertisers.

GUTTERS

GUTTERS, Cast Iron Gutters, L. & B. Improved V Shaped Gutter with drip gutter attachment. Lord & Burnham, 1133 Broadway, N. Y.

HAIL INSURANCE

Florists' Hail Assn. of America. J. G. Esler, Saddle River, N. J. For page see List of Advertisers.

HARDY FERNS AND SUPPLIES

- H. M. Robinson & Co., 15 Province St. and 9 Chapman Pl., Boston, Mass. For page see List of Advertisers.
- The Kervan Co., 113 W. 28th St., N. Y. For page see List of Advertisers.
- Michigan Cut Flower Exchange, 38 and 40 Broadway, Detroit, Mich. Fancy Ferns. For page see List of Advertisers.

A full line of ferns, galax, and all wild greens. N. F. McCarthy & Co., 84 Hawley St., Boston.

In writing to Advertisers kindly mention Horticulture

HARDY HERBACEOUS PLANTS

- Bay State Nurseries, N. Abington, Mass.
For page see List of Advertisers.
- New England Nurseries, Inc., Bedford, Mass.
For page see List of Advertisers.

HEATING APPARATUS

- Lord & Burnham Co.,
1133 Broadway, New York.
For page see List of Advertisers.
- Pierson U-Bar Co., 1 Madison Sq., N. Y.
For page see List of Advertisers.
- Hitchings & Co., 1170 Broadway, N. Y.
For page see List of Advertisers.
- John A. Payne, 260-274 Culver Ave., Jersey City, N. J.
For page see List of Advertisers.
- The Castle Co., 170 Summer St., Boston.

HELP FURNISHED

- Thos. H. Bambrick, 34 S. 7th St., Phila.
For page see List of Advertisers.
- HORICUM**
- Hammond's Paint & S. S. Wks., Fishkill-on-Hudson, N. Y.
For page see List of Advertisers.

HOT-BED SASH

- The A. T. Stearns Lumber Co., Neposset, Mass.
For page see List of Advertisers.
- Pierson U-Bar Co., 1 Madison Sq., N. Y.
For page see List of Advertisers.
- Hitchings & Co., 1170 Broadway, N. Y.
For page see List of Advertisers.
- Lord & Burnham Co., 1133 Broadway, N. Y.
For page see List of Advertisers.
- Foley Mfg. Co., between Western Ave. and 26th St., Chicago, Ill.

INSECTICIDES.

- Carman's Ant-pest.
Perfection Chemical Co., Flushing, N. Y.
W. W. Rawson & Co., 5 Union St., Boston.
For page see List of Advertisers.
- Nicotinide kills all greenhouse pests
P. R. Palethorpe Co.,
Eleventh St., Owensboro, Ky.
For page see List of Advertisers.
- B. G. Pratt Co., 11 Broadway, New York.
For page see List of Advertisers.
- Andrew Wilson, Summit, N. J. Dept. 8.
Plant Oil.
- For Sale—Tobacco Stems and Tobacco Dust. Stems, 1-2c. per lb. in bale lots. Dust, 2c. per lb. in case lots. Weight of bale or case 300 to 400 lbs. each. S. R. Levy, Binghamton, N. Y.

JAPANA CUT FLOWER HOLDER

- M. V. Gurnsey, 130 So. Wadola Av., La Grange, Ill. Dept. F.
For page see List of Advertisers.

KENTIAS

- A. Leuthy & Co., Roslindale, Mass.
For page see List of Advertisers.
- Godfrey Aschmann, 1012 W. Ontario St., Philadelphia.
For page see List of Advertisers.

LEADING RETAIL FLORISTS

- Park Floral Co., Denver, Colo.
For page see List of Advertisers.
- George H. Cooke, Washington, D. C.
For page see List of Advertisers.
- Gude Bros. Co., 1214 F St., Washington, D. C.
For page see List of Advertisers.
- Atlanta Floral Co., Atlanta, Ga.
For page see List of Advertisers.
- P. J. & J. E. Hauswirth, 232 Michigan Ave., Chicago.
For page see List of Advertisers.
- William J. Smyth, Michigan Ave. and 31st St., Chicago.
For page see List of Advertisers.

LEADING RETAIL FLORISTS**Continued**

- Jacob Schulz, 644 4th Ave., Louisville, Ky.
For page see List of Advertisers.
- Thos. F. Galvin, 124 Tremont St., Boston.
For page see List of Advertisers.
- Jullus A. Zinn, 2 Beacon St., Boston.
For page see List of Advertisers.
- Houghton & Clark, 396 Boylston St., Boston.
For page see List of Advertisers.
- Sidney Hoffman, 59-61 Massachusetts Ave., Boston.
For page see List of Advertisers.
- J. Breitmeyer's Sons, Detroit, Mich.
For page see List of Advertisers.
- Samuel Murray, 1017 Broadway, Kansas City, Mo.
For page see List of Advertisers.
- Wm. L. Rock Flower Co., 1116 Walnut St., Kansas City, Mo.
For page see List of Advertisers.
- Fred C. Weber, 4326 Olive St., St. Louis, Mo.
For page see List of Advertisers.
- H. G. Eyres, 11 N. Pearl St., Albany, N. Y.
For page see List of Advertisers.
- David Clarke's Sons, 2139-2141 Broadway, New York.
For page see List of Advertisers.
- W. H. Donohoe, 17 E. 28th St., New York.
For page see List of Advertisers.
- Alex. McConnell, New York.
For page see List of Advertisers.
- Robert G. Wilson, Fulton St. and Greene Ave., Brooklyn, N. Y.
For page see List of Advertisers.
- Thomas Young, Jr., New York.
For page see List of Advertisers.
- Young & Nugent, 42 W. 29th St., N. Y.
For page see List of Advertisers.

LOBELIAS

- Jos. Fuller, 31 Orchard St., Leominster, Mass.
Carter's Double Blue Lobelia.
For page see List of Advertisers.

NEW AND RARE PLANTS

- Rose Hill Nurseries, New Rochelle, N. Y.
For page see List of Advertisers.

NICO-FUME

- Kentucky Tobacco Product Co., Louisville, Ky.
For page see List of Advertisers.

NURSERY STOCK

- John Waterer & Sons, Ltd.,
American Nursery, Bagshot, England.
For page see List of Advertisers.
- New England Nurseries, Bedford, Mass.
Shrubs, Roses and Herbaceous Perennials.
Specimen Pyramidal Box.
For page see List of Advertisers.
- Bay State Nurseries, N. Abington, Mass.
Herbaceous Perennials, Hardy Ornamental Trees.
For page see List of Advertisers.
- Cleary's Horticultural Co., 62 Vesey St., New York.
For page see List of Advertisers.
- P. Ouwerkerk, 216 Jane St., Weehawken Heights, N. J.
Holland Nursery Stock for Foreign.
For page see List of Advertisers.
- Nursery Stock. N. F. McCarthy & Co., 84 Hawley St., Boston, Mass.
- A. Van Leeuwen, Jr. H. H. De Wildt.
THE HORTICULTURAL CO.
Landscape Department. Office & Nurseries,
Worcester, Mass. Castle, N. C.
What have you got to sell?
We are buying.

ORCHID PLANTS

- Lager & Hurrell, Summit, N. J.
For page see List of Advertisers.
- Sander, St. Albans, England.
Importers, Exporters, Growers, Hybridists
For page see List of Advertisers.

ORCHID PLANTS—Continued

- Jullus Roehrs Co., Rutherford, N. J.
For page see List of Advertisers.
- Carrillo & Baldwin, Secaucus, N. J.
For page see List of Advertisers.
- Jos. A. Manda, 191 Valley Road, W. Orange, N. J.
For page see List of Advertisers.
- Ordenez Bros., Madison, N. J., Box 106.
For page see List of Advertisers.

PALMS

- A. Leuthy & Co., Perkins St. Nurseries,
Roslindale, Mass.
For page see List of Advertisers.
- Robert Craig Co., Market and 49th Sta.,
Philadelphia, Pa.
- Kentia, Phoenix, etc., all sizes. Write for new price list. Jullus Roehrs Co., Rutherford, N. J.

PAINT AND PUTTY

- PAINT AND PUTTY: Ideal Greenhouse lead; Special Greenhouse Putty. Lord & Burnham, 1133 Broadway, N. Y.

PLANT PROTECTORS

- J. H. Haley, Munith, Mich.
Concrete Plant Protector for Tomato Growing.
For page see List of Advertisers.

PANSY PLANTS.

- Choice pansy plants, 50c. per 100; \$4.00 per 1000. Cash. Aug. Zirniglel, Needham, Mass.

PATENTS

- Siggers & Siggers, Washington, D. C.
For page see List of Advertisers.

PEAT

- Orchid peat, Rotted peat, Azalea peat, Leaf-Mould, Live Sphagnum moss, Baled Sphagnum moss, Green Clump moss, etc. Jobbers' list on application. C. W. Brownell & Co., Walden, N. Y.

PEONIES

- One of the finest collections in America. Send 25 cts. in stamps for new edition of Peony Manual. C. S. Harrison's Select Nursery, York, Neb.

PHLOXES

- Send 25 cts. in stamps for Phlox Manual. Fine mixed phloxes \$1.50 per 100. C. S. Harrison's Select Nursery, York, Neb.

PIPE AND FITTINGS

- Foley Mfg. Co., between Western Ave. and 26th St., Chicago, Ill.
- PIPE AND FITTINGS. Cast Iron and Wrought Pipe, Valves, Elbows, Pipe Hooks, Automatic Air Headers, etc. Lord & Burnham, 1133 Broadway, N. Y.

PLANT BED CLOTH

- Mineralized Rubber Co., 18 Cliff St., N. Y.
For page see List of Advertisers.

POT HANGERS

- Pot hangers, Kramer's \$1 doz. by exp. \$1.25 by mail. I. N. Kramer & Son, Cedar Rapids, Ia.

PRUNING SHEARS

- Rhodes Mfg. Co., Grand Rapids, Mich.
Dept. R.
For page see List of Advertisers.

RAFFIA

- Raffia (colored), 20 beautiful shades. Samples free. R. M. Coney Co., Camden, N. J.; 810 Washburn Ave., Chicago, Ill.

RHODODENDRONS

- John Waterer & Sons, Ltd.,
American Nursery, Bagshot, England.
For page see List of Advertisers.

For List of Advertisers See Page 156

ROSES

Julius Roehrs Co., Rutherford, N. J.
Rambler Rose, Newport Fairy.
For page see List of Advertisers.

New England Nurseries, Inc., Bedford, Mass.
Roses for Forcing.
For page see List of Advertisers.

Bay State Nurseries, N. Abington, Mass.
Roses for Forcing.
For page see List of Advertisers.

Ellwanger & Barry, Rochester, N. Y.
Hardy Roses.
For page see List of Advertisers.

John Cook, 318 Charles St., N. Baltimore, Maryland.
Rose My Maryland.
For page see List of Advertisers.

Boblink & Atkins, Rutherford, N. J.
For page see List of Advertisers.

Robert Craig Co., Market and 49th Sts., Philadelphia, Pa.
A. N. Pierson, Cromwell, Conn.
Grafted and Own Root Roses.

S. S. Pennock-Meehan Co., Philadelphia.
Rose Mrs. Jardine.

W. P. Craig, 1305 Filbert St., Philadelphia.
Rose Mrs. Jardine.

400 varieties; own roots; summer grown. Leedle Company, Springfield, Ohio.
Crimson Ramblers, 2 year, on own roots, extra strong, at 7 cents. Gilbert Costich, Rochester, N. Y.
Low-budded roses, No. 1, \$95.00; No. 11-2, \$65.00 1000. H. T. Jones, Elizabeth, N. J.
The beautiful new pink rose, MISS KATE MOULTON is the queen of all pink roses. It's a winner and you should grow it. Price \$30.00 100; 500 \$125.00; 1000 \$200.00; 5000 and upwards \$175 per 1000. Minneapolis Floral Co., Minneapolis, Minn.

SCALECID

B. G. Pratt Co., 11 Broadway, New York.
For page see List of Advertisers.

SEEDS

T. J. Grey Co., 32 So. Market St., Boston, Mass.
For page see List of Advertisers.
Joseph Breck & Sons,
51 and 52 N. Market St., Boston, Mass.
For page see List of Advertisers.

W. Atlee Burpee & Co., Philadelphia.
For page see List of Advertisers.

J. M. Thurburn & Co., 33 Barclay St., N. Y.
For page see List of Advertisers.

A. T. Boddington, 342 W. 14th St., N. Y.
Vinca Seed.
For page see List of Advertisers.

H. F. Mitchell Co., 1017 Market St., Phila.
For page see List of Advertisers.

James Vlek's Sons, Rochester, N. Y.
Vlek's Superb Pansy Seed.
For page see List of Advertisers.

Hjalmar Hartmann & Co.,
12 Stormgade, Copenhagen, Denmark.
Cauliflower and Cabbage Seed.
For page see List of Advertisers.

Rickards Bros., 37 E. 19th St., New York.
For page see List of Advertisers.

R. & J. Enrquhar & Co., 6-7 So. Market St., Boston.
Giant Cyclamen Seed.
For page see List of Advertisers.

C. C. Morse & Co., 48-56 Jackson St., San Francisco, Cal.
For page see List of Advertisers.

H. E. Fiske Seed Co., Faneuil Hall Sq., Boston.
For page see List of Advertisers.

Braslan Seed Growers Co., San Jose, Cal.
For page see List of Advertisers.

O. V. Zangen, Hoboken, N. J.
For page see List of Advertisers.

R. Wibott, Nakskov, Denmark.
Snowball Cauliflower Seed.
For page see List of Advertisers.

Sauder & Son, Bruges, Belgium.
Cocos Weddelliana Seed.

Crego aster seed. Ask for circular. G. S. Crego, Maywood, Ill.

SMILAX

E. A. Beaven, Evergreen, Ala.
Southern Wild Smilax; Log Mosses.
For page see List of Advertisers.

SPHAGNUM MOSS

Live Sphagnum moss, orchid peat and orchid baskets always on hand. Lager & Hurrell, Summit, N. J.
Fresh, clean, 5 bbl. bale, \$1.25; 2 bales, \$2.25; 5 bales, \$5.00; 10 bales, \$9.50. Cash. H. R. Akers, Chatsworth, N. J.

STEAM TRAP

E. Hippard, Youngstown, O.
For page see List of Advertisers.

VENTILATING APPARATUS

Pierson U-Bar Co., 1 Madison Sq., N. Y.
For page see List of Advertisers.

Hitchings & Co., 1170 Broadway, N. Y.
For page see List of Advertisers.

Foley Mfg. Co., between Western Ave. and 26th St., Chicago, Ill.
For page see List of Advertisers.

John A. Payne, 260-274 Culver Ave., Jersey City, N. J.
For page see List of Advertisers.

VENTILATING MACHINERY, New Model encased, self-oiling gear; Standard Model Open Gear. Lord & Burnham, 1133 Broadway, N. Y.

VIOLETS

William Sim, Cliftondale, Mass.
Violet Boston.
For page see List of Advertisers.

WIREWORK

Reed & Keller, 122 W. 25th St., N. Y.
For page see List of Advertisers.

Wirework. Write for our catalogue. Holton & Hunkel Co., Milwaukee, Wis.
William E. Heilscher's Wire Works, 38-40 Broadway, Detroit, Mich.
The "Just Right" kind. Send for price list. Frank W. Ball, 31 East Third Street, Cluehmatl, O.

WHOLESALE FLORISTS

Boston

N. F. McCarthy & Co., 84 Hawley St., Boston.
For page see List of Advertisers.

H. M. Robinson & Co., 15 Province St. and 9 Chapman Pl., Boston.
For page see List of Advertisers.

Welch Bros., 226 Devonshire St., Boston.
For page see List of Advertisers.

Buffalo

Wm. F. Kasting Co., 383-87 Elliott St., Buffalo, N. Y.
For page see List of Advertisers.

Chicago

Chas. W. McKellar, 51 Wabash Ave., Chicago.
For page see List of Advertisers.

Peter Reinberg, 51 Wabash Ave., Chicago.
For page see List of Advertisers.

E. F. Winterson Co., 45-49 Wabash Ave., Chicago.
For page see List of Advertisers.

Detroit

Michigan Cut Flower Exchange, 38 and 40 Broadway, Detroit, Mich.
For page see List of Advertisers.

New York

J. K. Allen, 106 W. 28th St., New York
For page see List of Advertisers.

J. S. Fenrich, 110 W. 28th St., New York.
For page see List of Advertisers.

Ford Bros., 48 W. 28th St., New York.
For page see List of Advertisers.

WHOLESALE FLORISTS—

New York—Continued

H. E. Froment, 57 W. 28th St., New York.
For page see List of Advertisers.

Alex. J. Guttman, 43 W. 28th St., New York.
For page see List of Advertisers.

E. C. Horan, 55 W. 28th St., New York
For page see List of Advertisers.

A. H. Langjahr, 55 W. 28th St., New York.
For page see List of Advertisers.

James McMauns, 42 W. 28th St., New York.
For page see List of Advertisers.

Chas Millang, 50 W. 29th St., New York.
For page see List of Advertisers.

John J. Raynor, 49 W. 28th St., New York.
For page see List of Advertisers.

W. F. Sheridan, 39 W. 28th St., New York.
For page see List of Advertisers.

Friendly & Schenck, 44 W. 28th St., New York.
For page see List of Advertisers.

John Young, 51 W. 28th St., New York.
For page see List of Advertisers.

Moore, Heutz & Nash, 55 and 57 W. 26th St., New York.
For page see List of Advertisers.

Frank S. Hicks & Co., 52 W. 28th St., New York.
For page see List of Advertisers.

Frank Millang, 57 W. 26th St., New York.
For page see List of Advertisers.

Wm. H. Kuebler, 28 Willoughby St., Brooklyn, N. Y.
For page see List of Advertisers.

Philip F. Kessler, 55 and 57 W. 26th St., New York.
For page see List of Advertisers.

A. Moltz, 55-57 W. 26th St., New York.
For page see List of Advertisers.

B. S. Slinn, Jr., 55 W. 26th St., New York.
For page see List of Advertisers.

A. L. Young & Co., 54 W. 28th St., New York.
For page see List of Advertisers.

Philadelphia

W. E. McKissick, 1221 Filbert St., Philadelphia, Pa.
For page see List of Advertisers.

Leo Niessen Co., 1209 Arch St., Philadelphia, Pa.
For page see List of Advertisers.

The S. S. Pennock-Meehan Co., 1608-18 Ludlow St., Philadelphia, Pa.
For page see List of Advertisers.

Edward Reid, 1526 Raustead St., Philadelphia, Pa.
For page see List of Advertisers.

A. M. Campbell, 1510 Sansom St., Philadelphia.
For page see List of Advertisers.

Wm. J. Baker, South Penn. Square, Philadelphia, Pa.

Pittsburg

J. B. Murdoch & Co., 714 Penn Ave., Pittsburg, Pa.
For page see List of Advertisers.

San Francisco

Alex. Manu, Jr., Co., 1125 Polk St., San Francisco, Cal.
For page see List of Advertisers.

St. Louis

H. G. Berning, 1402 Pine St., St. Louis, Mo.
For page see List of Advertisers.

WHOLESALE PLANT MARKETS

Philadelphia Plant Exchange, 839 Market St., Philadelphia.
For page see List of Advertisers.

WHOLESALE PLANTSMAN

Samuel A. Woodrow, 53 W. 30th St., New York.
For page see List of Advertisers.

In writing to Advertisers kindly mention Horticulture

List of Advertisers

Table listing advertisers and their page numbers. Includes entries like Allee J. K., American Nursery, Aschmann Godfrey, Atlanta Floral Co., Bambrick Thos., etc.

New Offers in This Issue.

ANNOUNCEMENT. American Nursery Co., 150 Broadway, New York, N. Y. For page see List of Advertisers. CARNATIONS. Charles H. Totty, Madison, N. J. For page see List of Advertisers. CARNATIONS, IMPERIAL AND PINK IMPERIAL. John E. Haines, Bethlehem, Pa. For page see List of Advertisers. ORCHIDS FOR SPRING DELIVERY. J. A. Manda, 191 Valley Road, W. Orange, N. J. For page see List of Advertisers. RETAIL FLORISTS. J. N. Champion & Co., 1026 Chapel St., New Haven, Conn. For page see List of Advertisers. SUPERB DOUBLE PETUNIAS. Henry A. Dreer, Philadelphia. For page see List of Advertisers. SALESMAN WANTED. Kramer Bros. Foundry Co., Dayton, O. For page see List of Advertisers. WHOLESALE FLORIST. J. Kopelman & Co., 21 Washington St., Providence, R. I. For page see List of Advertisers. WHOLESALE FLORIST. J. J. Harty & Co., 1312 G. St. N. W., Washington, D. C. For page see List of Advertisers.

HELP WANTED

WANTED—SALESMAN To Handle Good Side Line On Commission One who calls on Florists, Seed Houses, Nurseries, Cemetery Superintendents, Monument Dealers, etc. The Kramer Bros. Foundry Co. DAYTON, OHIO

SITUATIONS WANTED

GOOD MEN When you need good men, skilled or unskilled, Write: THOS. H. BAMBRICK 34 South 7th Street Philadelphia Help of all kinds, including that for Florists, Nurserymen, Seedsmen and the Horticultural trade generally.

WANTED—Position in general greenhouse work; single; age 35; lifelong experience; understand every detail of growing, etc. Address P. A., care HORTICULTURE.

SITUATION WANTED in general greenhouse work; single, age 35, five years' experience, commercial. Address W. W., care HORTICULTURE.

FOR SALE

FOR SALE—Ten acres of fine soil for roses and carnations; five greenhouses recently built, heated with steam, boiler capable to heat three times as much glass. The houses are stocked with roses and aulantums. Excellent railway facilities; 22 miles from Philadelphia. Price, \$4,500. Possession immediately or April 1. Address P. O. Box 77, North Wales, Pa.

FOR SALE—A large consignment of 16x24 double thick American glass, A and B quality. For further information write Parselsky Brothers, 59 Montrose Avenue, Brooklyn, N. Y.

MISCELLANEOUS WANTS

WANTED at once, to lease in Eastern States with privilege of buying, 5,000 to 10,000 feet of glass, with some land, suitable for retail trade or market gardening. Give full particulars in first letter. Address Horticulturist, care HORTICULTURE.

leaves a widow, two sons and three daughters.

Christopher H. Shaffer.

Christopher H. Shaffer, of Cascade, la., died on January 7, aged 84.

SOCIETY OF AMERICAN FLORISTS AND ORNAMENTAL HORTICULTURISTS.

Department of Plant Registration. Mr. Paul Niehoff, of Lehighton, Pa., desires to change the name of his pink rose registered as "Aurora" to "Mrs. Mary Niehoff," as he learned that there is a European variety bearing the former name. W. N. RUDD, Sec'y.

OBITUARY.

William H. Ford.

William H. Ford died at his home in Salem, Mass., January 19. He was rounding out eighty-seven years of life, thirty of which had been spent at Pride's Crossing, Mass., as superintendent of the Brimmer estate now owned by H. M. Sears. Born in Ireland, County Kilkenny, he came to America in 1850, and had charge of various large estates before he went to the Brimmer estate. The work here will long remain a tribute to his skill, the formal garden having few rivals in New England. For the last three years he has made his home in Salem. Of genial, kindly temperament, combined with rare qualifications and artistic abilities, Mr. Ford will be greatly missed by those who knew him. A widow and seven children survive. Charles B. succeeded his father at Pride's.

J. F. Noll.

J. F. Noll, born in Morristown, Pa., April 30, 1870, died at his home in Newark, N. J., on January 22. Mr. Noll was a pleasant, energetic, young man, and during the eight years in which he had been engaged in the seed business he built up a large trade. His widow will carry on the business.

James Henry Durkee.

James H. Durkee, a prominent agriculturist of New York, died on Jan. 25 at Sandy Hill. Mr. Durkee was born in 1848 in Fort Edward, graduated at Cornell, and held many positions of trust in agricultural organizations at the time of his death.

Simon Held.

Simon Held, aged 79, a well-known gardener, died on Jan. 19 at the Home for the Aged at Fair Oaks, Pa. He

Is Your Name In The Above List? If Not, Why Not?

PARK AND FORESTRY ASSOCIATION.

The Park and Forestry Association meeting was held in Lincoln, Neb., Jan. 23. An interesting program was given. E. C. Bishop, Deputy Superintendent of Public Instruction, spoke of planting and caring for trees on school grounds. E. F. Stephens of Crete, the veteran tree planter of Nebraska, spoke of the best varieties of trees for planting in the West. Prof. Chas. E. Bessey gave a very fine paper on the different kinds of poplars and emphasized the importance of planting the Norway Poplar, which is now so highly recommended by the Forestry Department. According to Prof. Bessey, this should be called *Populus laurifolia*. In the discussion connected with this tree, it was decided that it was the most rapid growing of any tree in the northern states. Thousands have been planted at the York Experiment Station and their growth was something wonderful. One year they made nine feet from cuttings. This year, fence posts were cut from four-year-old trees which measured fifteen inches in circumference, three feet from the ground. Prof. F. J. Phillips gave a very interesting account of the progress of the government planting on the Dismal River. The work there is succeeding admirably. C. S. Harrison, the president, spoke of the great debt which Nebraska owes herself which should be paid as soon as possible. He emphasized the fact that for over thirty years the saline lands lying near Lincoln had been wholly unimproved, and their desolate and naked appearance was an absolute disgrace to the Capital city. He also spoke of the duty of the state toward redeeming the sand wastes of the North, where worthless land could soon be transformed into fine parks and sanitariums, as that is one of the healthiest regions in the West. He emphasized the fact that Nebraska was a great and rich state, but it seemed very hard for our legislators to break away from the early grasshopper conditions and realize that they have something more to do than simply guard the state treasury. The former secretary, L. D. Stilson, being very low with a probably fatal disease, L. B. Craig was chosen to take

his place as secretary. The other officers were re-elected.

LIST OF PATENTS.

Issued January 7, 1908.

- 875,690. Check Row Planter. Christopher C. Butcher, Urbana, Mo., assignor of one-third to Edward L. Russell, Urbana, Mo.
- 875,827. Harrow. Reuben A. Koeller, Colvinpark, Ill.
- 875,831. Pea and Bean Harvester. James C. Longstreet, Jackson, Miss.
- 875,846. Hay and Manure Gatherer and Loader. John Peterson, St. Paul, Minn.
- 875,946. Weeder and Cultivator. Nels P. Nelson, Lexington, Ore.
- 876,145. Disk Harrow and Weeder. Frank Buchet and Elmer A. Mullinix, Walla Walla, Wash.
- 876,235. Adjustable Flower Box. Leonard G. Quackenboss, Chicago, Ill.

Issued January 14, 1908.

- 876,513. Cultivator. Silas E. Bailor, Tarkio, Mo.
- 876,538. Seed Planter. John H. Gardner, Dalton, Ga.
- 876,649. Hoe. Charles A. Long, Spokane, Wash.
- 876,651. Cutting Apparatus for Mowers. Walter J. Needham, Myra, Tex.
- 876,665. Lawn Mower. Earl M. Stapleton, Cedar Vale, Kans.
- 876,697. Lawn Mower Grass Receptacle. David G. Davis, Ellensburg, Wash., assignor of one-half to George R. Bradshaw, Ellensburg, Wash.

HORTICULTURE STUDY AT WELLESLEY.



Our illustrations show the new greenhouses for laboratory work, at Wellesley College, Mass., completed last October by the Lord & Burnham Company, at a cost of several thou-

sand dollars. The greenhouse is a wing of the "Botany annex," a building well adapted and primarily intended for the gardening course which many of the young ladies are taking,

under the direction of H. S. Adams. With the opening of the spring the exterior wall will be hidden by a planting of *Ampelopsis Veitchii* and hardy ferns.

"SCALECIDE"

HAS MADE SPRAYING EASY THEN WHY NEGLECT YOUR TREES?

The N. Y. Herald, November 17, '07, says: "The chances are about a hundred to one that you have the San Jose Scale on your place and do not know it," and advises the use of "SCALECIDE." This is good advice. "SCALECIDE" has been tested and tried, and found thoroughly effective. The same yesterday, to-day, and all the time. One gallon makes 15 to 20, ready to use, by simply adding water.

Prices: 1 gal., \$1.00; 5 gal., \$3.25; 10 gal., 6.00; 50 gal. bbl., \$25.00, F. O. B. our factory. Order to-day. Write for booklet W and free sample.

B. G. PRATT CO., Mfg. Chemists,
11 Broadway, New York City.



I MANUFACTURE AND ERECT

Iron frame and wood Greenhouses of every type for commercial and private use. If you contemplate building, allow me to submit sketch and estimate covering your requirements.

JOHN A. PAYNE,
Horticultural Architect and Builder.

Main Office and Factory:
260-274 Culver Ave., Jersey City, N.J.
Sash opening apparatus and all kinds of greenhouse structural material.

GREENHOUSES BUILDING OR CONTEMPLATED.

- St. Louis, Mo.—C. De Wever, range of houses.
- Canon City, Colo.—E. L. Cleveland, one house.
- Brookfield, Mo.—Gertrude Jones, house 30x100.
- Milwaukee, Wis.—H. Schwabke, range of houses.
- Two Rivers, Wis.—Louis Hartung, range of houses.
- Oakland, Cal.—P. McDonnell, two carnation houses.
- Elmhurst, Cal.—G. W. Simmons, three rose houses.
- Atchison, Kan.—W. S. Bissel, vegetable house, 40x60.

Tobacco Paper "NICO-FUME" **LIQUID**
 IS THE **STRONGEST,**
BEST PACKED,
EASIEST APPLIED.
 24 sheets.....\$ 0.75
 144 sheets..... 3.50
 288 sheets..... 6.50
 1728 sheets..... 35.10

Furnishes the Most Nicotine for the Money!
 ... Manufactured by ...
THE KENTUCKY TOBACCO PRODUCT CO., Louisville, Ky.

OVER 40% NICOTINE
 By far the **CHEAPEST.**
JUST NOTE PRICES!
 Pint.....\$ 1.50
 1/2 Gallon..... 5.50
 Gallon..... 10.50
 5 Gallons..... 47.25

GREENHOUSE GLASS
Cheaper Now Than For Years
 We are taking contracts for next Spring delivery.
WRITE FOR OUR PRICES
STANDARD PLATE GLASS COMPANY
 26-30 Sudbury St. 61-63 Portland St.
 BOSTON, MASS.

"HORICUM" "SOLD BY THE SEEDSMEN"
 TRADE MARK
"HORICUM"
KILLS SAN JOSE SCALE
 Directions for Use.
 This preparation is Lime, Sulphur and Salt, making a concentrated Poly-sulphide of Calcium. The Salt adds to the adhesive properties, but the destructiveness to Scale Life lies in the Calcium Sulphide. Aside from its ability to destroy San Jose Scale, Horicum is a Fungicide, preventing the free development of fungid troubles.
 Shake package thoroughly or take the top off. The color in its concentrated form is a deep bronze green. Do not pour off the clear liquor only, stir the Horicum from the bottom of the package, add 20 parts of water (hot, if you can get it) for ordinary use. For a stronger dilution when the growth is all dormant, use 10 parts of water only (hot, if you have it) and spray thoroughly. By grading your dilution you make it any desired strength. Specific gravity, 1.56. Total Poly-sulphides, 30% by weight. Send for pamphlets to
HAMMOND'S SLUG SHOT WORKS
 Fishkill-on-Hudson, N. Y.

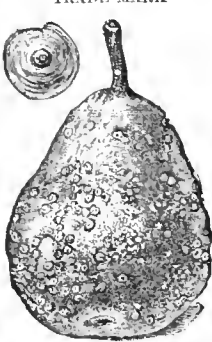

San Jose Scale on a Pear.
Kills San Jose

PATENTS
 Trademarks and Copyrights
 Send other business direct to Washington. Saves time and insures better service. Personal attention guaranteed. Twenty-five years' active service. SPECIALTY: "Working on the Failures of Others."
SIGGERS & SIGGERS
 PATENT LAWYERS
 Box 9, National Union Building
 Washington, D. C.

RHODES DOUBLE CUT PRUNING SHEAR
 Pat'd June 2, 1903.
 THE only pruner made that cuts from both sides of the limb and does not bruise the bark. Made in all styles and sizes. We pay Express charges on all orders. Write for circular and prices.
RHODES MFG. CO.,
 GRAND RAPIDS, MICH.

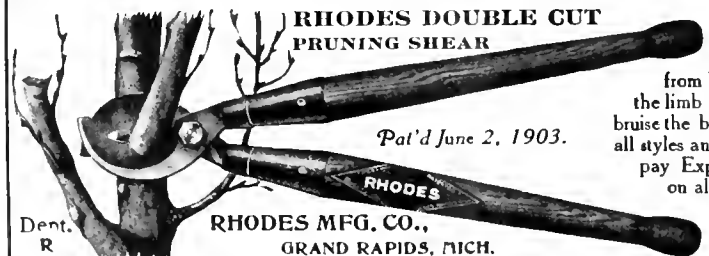

STANDARD FLOWER POTS
 Packed in small crates, easy to handle.

1500 2 1/2 in. pots in crate \$4.88	120 7 in. pots in crate \$4.20	
1500 3 1/4 " " " 5.25	60 8 " " " 3.00	
1500 4 " " " 6.00	HAND MADE	
1000 3 " " " 5.00	48 9 in. pots in crate \$3.60	
800 3 1/2 " " " 5.80	48 10 " " " 4.80	
500 4 " " " 4.50	24 11 " " " 3.60	
320 3 " " " 4.51	24 12 " " " 4.80	
144 6 " " " 3.16	12 14 " " " 4.80	
	6 16 " " " 4.50	

 Seed pans, same price as pots. Send for price list of Cylinders for Cut flowers, Hanging Baskets, Lawn Vases, etc. Ten per cent. off for cash with order. Address **Hilfinger Bros., Pottery, Fort Edward, N. Y.**
 August Rolker & Sons, Agts., 31 Barclay St., N. Y. City.

ESTAB. 1765
A. H. HEWES & CO.
 NO. CAMBRIDGE MASS
 L. I. CITY N. Y.
 CATALOGUE FREE

The Best Bug Killer and Bloom Saver
NICOTICIDE BUG KILLER
 For PROOF Write to
P. R. Palethorpe Co.
 OWENSBORO, KY.



Standard Flower POTS
 If your greenhouses are within 500 miles of the Capitol, write us, we can save you money
W. H. ERNEST,
 28th and M Street WASHINGTON D. C.
The FLORISTS' HAIL ASSOCIATION OF AMERICA, insurer of 28,000,000 sq. ft. of glass. For particulars address **John C. Esler, Sec'y, Saddle River, N. J.**

GARMAN'S ANTIPEST
 For the Garden, Orchard and Greenhouse. Non-poisonous and harmless to vegetation. Kills Green Fly, Aphides, Bark Lice, Thrip, Mealy Bug, Red Spider, Scale, Wire Worms, Ants and Stugs.
 This is the Grower's Friend, handy to use, cheap and effective, mixes readily in water. Destroys all insect pests, and keeps down filth. Circulars on application \$1.50 per gallon. Also in quarts, half gallons and in bulk.
PERFECTION CHEMICAL CO.,
 FLUSHING, N. Y.
 Eastern Agents:
W. W. RAWSON & CO., 5 Union St Boston, Mass.

Wizard Brand Manures
Cattle Manure In Bags Shredded or Pulverized
 Best and safest manure for florists and greenhouse use, absolutely pure, no waste, no danger. Write for circulars and prices.
The Pulverized Manure Co.,
 31 Union Stock Yards, Chicago



WILLIAM H. LUTTON

HORTICULTURAL ARCHITECT AND BUILDER

WEST SIDE AVENUE STATION (C. R. R. OF N. J.)
JERSEY CITY, N. J.

Have not been established 50 years, but long enough to convince the wide-awake Florist and Gardener that it is to his interest to place his work in thoroughly practical hands.

(150,000 sq. ft. glass erected in 1907 will substantiate this claim)

And why not? My material is the best that can be secured. My iron frame construction has every modern feature that years of practical experience can embody.

AND THEN THERE IS THE COST TO BE CONSIDERED.

Why not let us take up this important question now?

CYPRESS SASH BARS
 32 feet or longer
HOT BED SASH
PECKY CYPRESS BENCH LUMBER

GREENHOUSES
 ERECTED AND EQUIPPED COMPLETE IF DESIRED

Write for Circular "D" and Prices

The A. T. STEARNS LUMBER CO.
 NEPONSET, BOSTON, MASS.

METROPOLITAN MATERIAL CO.
 GREENHOUSE WRECKERS

GLASS Look at these prices. New American 50 ft. to the box, 10x12 single \$1.80 per box, 10x12, 12x12 B. double \$2.30 per box, 12x14, 12x20 and 14x14, 14x20 and 16x16, 16x18 B. double \$2.50 per box, 16x20, 16x24, 12x24 B. double \$2.65 per box. In lots of 10 boxes or more. Let us quote you on

CYPRESS MATERIAL HOTBED SASH
 BOILERS PIPE FITTINGS
 HOTBED FRAMES MATS
 1398-1408 METROPOLITAN AV., BROOKLYN, N. Y.

ANCHOR GREENHOUSE HOSE

WEARS WELL.

PLANT BED CLOTH

Protects from Cold and Dampness.

MINERALIZED RUBBER CO.

18 Cliff Street. New York

GREENHOUSE CONSTRUCTION LUMBER

John C. Moninger Co.
 117 E. Blackhawk St., CHICAGO



GREENHOUSE MATERIAL AND FITTINGS

WRITE FOR PRICES

"1908 MODEL" VENTILATING MACHINE

SIMPLEST AND MOST DURABLE MACHINE
 NOW ON THE MARKET: EASILY ERECTED

I. CASSIDY,
 DESIGNER AND BUILDER

Summer Ave. & Erie R. R.
 NEWARK, N. J.

THE STANDARD STEAM TRAP

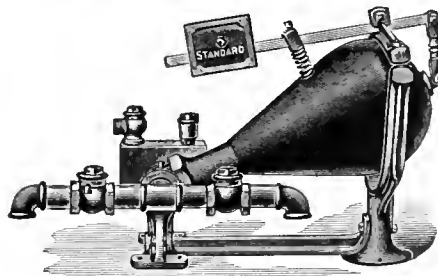

is acknowledged the best for the florist, because it is durable and does its work without trouble and annoyance, saving its cost by the economy in coal bills.

E. HIPPARD
 YOUNGSTOWN, OHIO

NOW IS THE RIGHT TIME TO FIGURE **MATERIAL** AND PLAN FOR THE BUILDINGS OF THIS YEAR

FOLEY'S } QUALITY AND WORK THE BEST.
 PRICES RIGHT AND LOWEST.
 ESTIMATES WILL PROVE. TRY US.

Foley Ventilating Apparatus Unequaled

Will ventilate any size of house easily. Send for circular.

THE FOLEY MFG. CO. Western Ave. 25th & 26th Sts. **CHICAGO**

Holds Glass Firmly
 See the Point AT **PEERLESS**
 FULL SIZE N° 2
 Glazing Points are the best. No rights or lefts. Box of 1,000 points 75 cts. postpaid.
HENRY A. DREER,
 714 Chestnut St., Phila., Pa.

BOSTON PLATE & WINDOW GLASS CO.

GREENHOUSE GLASS
 German and American

261 to 287 A St., BOSTON 20-22 Canal St.

In ordering goods please add, "I saw it in HORTICULTURE"

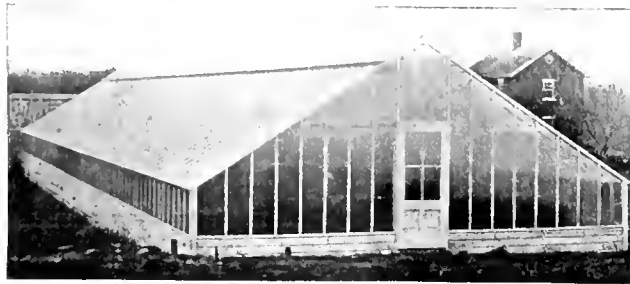

**WE ERECT COMPLETE OR
SELL MATERIALS FOR**

**All Iron Frame or
Half Iron Frame**

GREENHOUSES

**If You Contemplate Build-
ing, Send Us Particulars**

HITCHINGS & CO.

**1170 Broadway
NEW YORK**

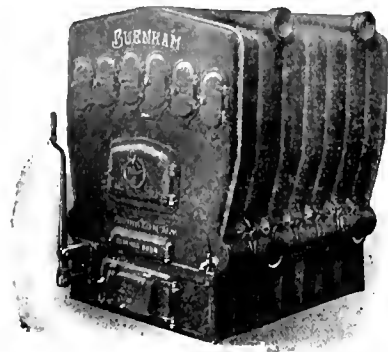

Is Your Cellar Shallow?

Then the "Burnham" with its two series,
fitted with hub connections on either side for
low flow pipes will help you out.

The "Burnham" is the tried and proven
coal economizer.

Send for Catalog showing 55
sizes for Greenhouse work.

LORD & BURNHAM CO.

**1133 BROADWAY, cor. 26th Street, N. Y.
BOSTON Branch: 819 Tremont Building
PHILADELPHIA Branch: 1215 Filbert St.**

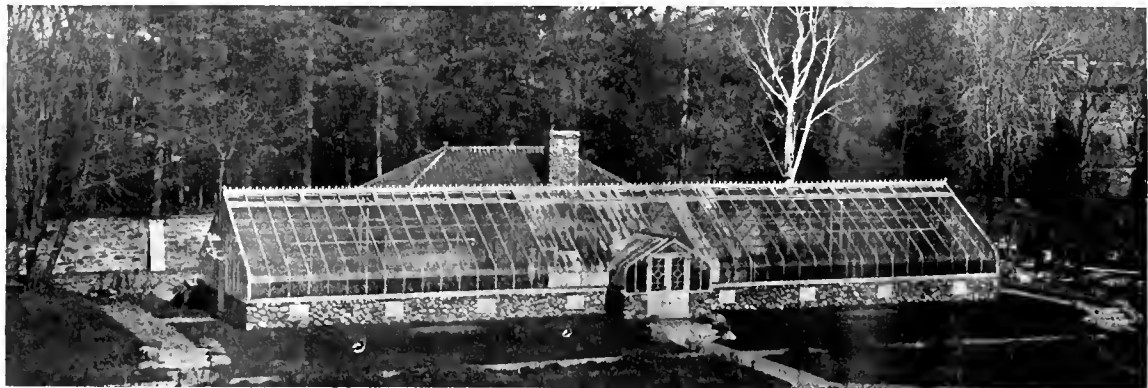

Here is another instance where the U-Bar house won out, simply because it was the U-Bar. Competition was perhaps as keen as we have yet experienced. We were given the contract simply because the U-Bar construction has certain unmatched points, all of which go toward producing better plants and more blooms than possible with any other construction. But the U-Bar house does not stop there, it is the most enduring. Every structural detail and possible decay point have been carefully taken care of. If it is not convenient for you to see a U-Bar house then send for the catalog. **Pierson U-Bar Company**, Designers and Builders *U-Bar Greenhouses*, Metropolitan Building, 4th Avenue and 23rd Street, New York.



HORTICULTURE

Vol. VII. FEBRUARY 8, 1908 No. 6



CELSIA ARCTURUS

Devoted to the
**FLORIST, PLANTSMAN,
LANDSCAPE GARDENER**
and
Kindred Interests

Published
EVERY SATURDAY
At 11 Hamilton Place,
BOSTON, MASS.
Subscription, \$1.00

PLATE 10

S. & W. CO.'S

New Crop Flower Seeds

ASTER

Queen of the Market. This is the earliest of all, fully three weeks earlier than other Asters.

	Trade pkt.	1/4 oz.	oz.
Selected white	10	15	50
Selected crimson	10	15	50
Selected rose	10	15	50
Selected light blue	10	15	50
Selected dark blue	10	15	50
Selected flesh color	10	15	50
Selected lilac red	10	15	50
Selected mixed	10	15	50
Giant Comet, pure white	25	75	2 00
Giant Comet, dark blue	25	75	2 00
Giant Comet, light rose	25	75	2 00
Giant Comet, mixed	20	60	1 75
Comet Emp. & Frederick, pure white	25	1 00	3 00
Comet King Humbert, giant pure white of the most refined comet shape	25	1 00	3 00
Dwarf Corysanthemum. Fine for growing for pot plants.			
Pure white	25	75	2 00
Dark blue	25	75	2 00
Scarlet	25	75	2 00
Mixed	20	50	1 75
Hohenzollern. Excellent robust new class, with enormous flowers, superb for cutting and exhibiting; flowers often measuring 6 to 8 inches in diameter.			
Hohenzollern, White	25	75	2 00
Rose	25	75	2 00
Dark blue	25	75	2 00
Crown Prince	25	90	3 00
Syringa blue	50	1 50	5 00
Mixed	25	75	2 00
Traut's Peony Flowered Perfection. A fine Aster either for pots or cutting.			
Pure white	20	50	1 75
Dark blue	20	50	1 75
Scarlet	20	50	1 75
Rose	20	50	1 75
Mixed	15	40	1 50
Victoria Dwarf.			
Pure white	25	75	2 50
Dark blue	25	75	2 50
Rose	25	75	2 50
Scarlet	25	75	2 50
Mixed	20	60	2 00
Dwarf Queen. Beautiful early class for pots, beds and borders.			
Dwarf Queen, White	20	75	2 00
Brilliant rose	20	75	2 00
Light blue	20	75	2 00
Dark blue	20	75	2 00
Crimson	20	75	2 00
Mixed	10	50	1 50
Carlson's Improved. A fine Aster for cutting.			
Carlson's Early, White	25	50	1 50
Carlson's Late, White	25	50	1 50
Pink	25	50	1 50
Lavender	25	50	1 50
Triumph.			
Dark Scarlet	25	90	3 00
Violet	25	90	3 00
White	25	90	3 00
Mixed	20	80	2 50
Purity, one of the finest white Asters grown either for pots or cutting.	25	75	2 50
Daybreak, counter part to Purity, with fine rose color			

Trade pkt. 1/4 oz. oz.

similar to Daybreak carnation; very fine

S. & W. Co.'s Selected Strain One of the best branching Asters for cut flowers. Our strain of this splendid Aster is grown specially for us, with the greatest care.

Pure white	20	30	1 00
Lavender	20	30	1 00
Purple	20	30	1 00
Crimson	20	30	1 00
Shell pink	20	30	1 00
Rose	20	30	1 00
Carmine	20	30	1 00
Mixed	10	20	75

BECONIA

Sempiternus Vernon, dark leaved	25	1 50	5 00
Comp. (Dwarf Vernon) dark leaved, per 1-64 oz., \$1.00	25		
Erfordia, rosy carmine, free bloomer, excellent for groups, 1000 seeds, 50c.	25		
Alba, 1-32 oz., 50c.	25		
Rosea, 1-32 oz., 50c.	25		

COSMOS

Mammoth, white	10	20	50
Mammoth, pink	10	20	50
Mammoth, red	10	20	50
Mammoth, mixed	10	30	75
New Early Flowering, mixed	15	35	1 00
Early Dawn,	10	30	75

DRACAENA

Indivisa, broad-leaved, in pods	15	25	75
--	----	----	----

FORGET-ME-NOT

(MYOSOTIS)

Robusta Grandiflora, (Elisa Fonerobert), large flowering, very fine for cutting	15	35	1 00
Victoria, dwarf, globular, sky blue flowers, finest for pots, with double central flower	25	50	1 50
Palustris, true marsh var.	25	75	2 50
Alpestris, mixed	15	25	75

FOXCLOVE

(DIGITALIS)

Gloxinia-flora, purple	10	25	
Gloxinia-flora, white	10	25	
Gloxinia-flora, rose	10	25	

LOBELIA (ERECTA, FOR POTS)

Erecta Crystal Palace, dark blue, for edgings and carpet bedding, excellent strain	25	75	2 50
Erecta Emperor William light blue, compact very fine	20	60	2 00
Erecta pumila, dark blue, clear white eye, extra	25	75	2 50
Erecta rosea,	20	50	1 50
Erecta White Gem	25	75	2 50
Pumila magenta, white eye	20		
(Erinus var., trailing)			
Erinus speciosa Crystal Palace,	10	30	1 00

Trade pkt. 1/4 oz. oz.

Erinus, royal purple, white eye	10	30	1 00
Erinus, Barbara's Perpetual, blue, white eye	20	50	1 50
Erinus, Prima Donna, velvety maroon (Hardy varieties.)	20	50	1 50
Queen Victoria, brilliant scarlet darkest leaves	25		

MIGNONETTE

Golden Queen, grandiflora, amica, flowers yellow, habit compact; per lb., \$3.00.	15	35	
Machet, Perfection, excellent for pots, thick spikes of reddish flowers, carefully selected strain; per lb., \$8.00.	10	25	75
Bismarck, new improved, extra	25	75	2 00
Ruby, new, a fine Machet mignonette, with coppery-scarlet flowers	20	50	1 50
Allen's Defiance, finest for cut flowers	10	50	1 50
Goliath, Red Giant	25	1 50	5 00

PETUNIA

S. & W. Co. Strain.

Fringed, Large-flowering, Double Mixed. Produce from 30 to 35 per cent. of plants, with charming double-fringed flowers; quality unsurpassed	1 00		
Large-flowering single fringed; 1-64 oz., \$1.00	50		
Unimitable, striped and blotched	10	40	1 00
Hybrida alba, white	10	40	1 00
Adonis, carmine, white throat	25	2 00	
Countess of Ellesmere, rose white	10	15	50

PYRETHRUM

Parthenifolium aureum (Golden Feather)	10	20	50
Golden Moss, (mass curled, distinct and charming), per 1-64 oz., \$3.00	25		

SALVIA

Anniversary	50	1 50	5 00
Splendens (Scarlet Sage)	15	50	1 50
Nana Compacta, Boule	25	75	2 50
Glory of Stuttgart	50	1 50	5 00

SMILAX (CLEAN SEED)

1/4 lb. \$1.00, lb. \$3.50.	10	30	
-----------------------------	----	----	--

TORENIA

Blue (Fournieri)	25		
Alba, white wings	25		
The Bride, large flowers, white and pink, per 1000 seeds, 50c.			

VERBENA

Mammoth varieties, Pink shades	25	50	1 50
Purple shades	25	50	1 50
White shades	25	50	1 50
Amriena flowered	25	50	1 50
Italian striped	25	50	1 50
Mixed	25	50	1 50
Choisy mixed	10	20	75

STUMPP & WALTER CO., 50 Barclay St., New York

Plant Rhododendrons

WE CAN SUPPLY YOU THE HARDY SORTS THAT GIVE SATISFACTION

- Azaleas
- Kalmias
- Andromedas
- Specimen Conifers



Choicest Nursery Stock Specially Grown for American Trade

A Field of Hardy Rhododendrons

The Finest Stock of Hardy Broad-Leaved Evergreens in the World.

Send list of your requirements for Spring trade now and we will reply with estimates.

JOHN WATERER & SONS, Ltd., AMERICAN NURSERY BAGSHOT, ENGLAND

Hardy Roses

American Grown—Superior to Imported

We have unsold at the present time the following varieties—all field grown plants, grown in our nurseries at Rochester, N. Y.:

- | | |
|---------------------|-----------------------|
| Anne de Diesbach | Prince Camille |
| Cllo | Elch Brunner |
| Frau Karl Druschki | Crimson Rambler |
| General Jacqueminot | White Rambler |
| John Hopper | Yellow Rambler |
| Mme. G. Luze | Philadelphia Rambler |
| Marshall P. Wilder | Common Sweet Briar |
| Mrs. John Luling | Mme. G. Brant |
| Paul Neyron | Wichuriana (The Type) |

These plants are in our storage cellars and can be shipped at any time. Prices on request.

ELLWANGER & BARRY

Nurserymen—Horticulturists

Mount Hope Nurseries, Rochester, N. Y.

Hardy Rhododendrons Azaleas Conifers, Clematis, H. P. Roses, Shrubs and Herbaceous Plants from our **HOLLAND NURSERIES**

Prices Moderate

P. DUWERKERK, 6 Jane St., Weehawken Heights P. O. No. 1 Hoboken, N. J.

AMERICAN NURSERY COMPANY COMBINING

FRED'K W. KEISEY New York City
F. & F. NURSERIES Springfield N. J.
BLOODGOOD NURSERIES, Flushing, L. I.
N. J. & L. I. NURSERIES.

We Can Supply Your Every Need. Write for Prices
SALES DEPARTMENT, 150 Broadway New York.

Established 40 Years

Rose Hill Nurseries

New and Rare Plants

NEW ROCHELLE, N. Y.

New York Office, Siebrecht Building, 425 Fifth Avenue

ROSES FOR FORCING Strong-Dormant

Immediate Delivery

Send for Prices and List

American Beauty, Clothilde Soupert, Gloire de Dijon, Hermosa, Kaiserin A. Victoria, Killarney, Liberty, La France, Maman Cochet, Marechal Neil, Mrs. R. G. Scharman-Crawford, Marchioness of Londonderry, Souv. de la Malmaison, including all the leading varieties of Hybrid Perpetuals.

BAY STATE NURSERIES, No. Abington, Mass.

NEW — NEW — RAMBLER ROSE "NEWPORT FAIRY"

To be disseminated Spring, 1908. Ask for illustrated pamphlet and prices

JULIUS ROEHRS CO., Rutherford, N. J.

ROSES Selected Stock for Forcing CRIMSON RAMBLER and DOROTHY PERKINS

3 to 4 ft. \$1.50 per 10, \$12.00 per 100; 4 to 5 ft. \$2.00 per 10, \$15.00 per 100

HYBRIDS—All Leading Varieties, \$1.50 per 10, \$12.00 per 100
General Catalog and Trade Lists on Application

The NEW ENGLAND NURSERIES, Inc., Bedford, Mass.

CANNAS 100,000 DAHLIAS

Send for our List and Prices

The CONARD & JONES CO. WEST GROVE, PA.

Premium Stock, guaranteed true to name.
500,000 large Flowering Gladioli, hundreds of colors and variations mixed. Wholesale prices on application. Order now for spring delivery. Catalogue free.

J. L. MOORE, Northboro, Mass.

DAHLIAS. Now is the time to place your order for bulbs which will insure you getting named varieties in any quantity; prompt delivery.

DAVID HERBERT & SON, Successors to L. K. Peacock, Inc. **ATCO, N. J.**

ROBERT CRAIG CO. ROSES, PALMS,

and Novelties in Decorative Plants

MARKET and 49th STREETS., PHILADELPHIA, PA.

NEW **My Maryland** ROSE

Best up-to-date commercial rose; read what others have to say about it.

Among the many new roses of the year there is none which has impressed us more as being worthy of a thorough trial. It has been exhibited only as 294, being a seedling raised by John Cook of Baltimore. A beautiful rose with an exquisite fragrance; in color it may be described as a soft salmon pink which brightens up beautifully as the bud opens. We are intending to plant this rose in quantity.

A. N. PIERSON, Cromwell, Conn.

In reply to your inquiry what we think of your new rose, My Maryland, we would say that after seeing others we still believe that you have the best new rose of modern times.

GUDE BROS., Washington, D. C.

Price 2 and 2½ inch pots, \$25 per 100 ; \$200 per 1000. Price 3 inch pots, \$5 per dozen.

JOHN COOK, 318 North Charles St. **Baltimore, Md.**

THE BOSTON VIOLET

The people today are looking for New Violets just as much as they are for new roses or carnations.

THE BOSTON VIOLET

For the past two years has been placed before the most sceptical buyers in America and they prefer it to any other.

THERE'S A REASON

The Boston Violet is the largest, the most fragrant, it has a very pleasing color, and it is a great keeper.

THE BOSTON VIOLET

Is a variety that is early grown, it is the strongest grower and is in crop from September to May.

THE BOSTON VIOLET

Was awarded a First Class Certificate of Merit by the Massachusetts Horticultural Society and a Report of Superior Merit by the Gardeners' and Florists' Club of Boston.

Distribution will Commence in April. Order Now.

PRICES — \$2 per 12 ; \$12 per 100 ; \$100 per 1000.

WILLIAM SIM, : : CLIFTONDALE, MASS.

Ruffled Gladioli



About a dozen years ago I began selections with a view to crossing in the hope of producing a frilled or ruffled gladiolus as beautifully formed as an azalea. I got the clue from observing in some gladioli a tendency to vary some from the regular smooth petals. After many matings and failures I was at last rewarded about five years ago by the desired results. The first flower to show was an ideal cream in color with tint of blush and a strikingly marked red feather on three lower petals. This flower is very massive, over 13-4 inches in diameter and an extra strong grower. From bottom of first blossom to tip of spike it measures 22 inches and over. The foliage is large. The variety shown in the illustration is white, somewhat smaller in size of flower than the cream colored sort above mentioned. There are several shades of pink and yellow, also purple, represented in the varieties now in process of development all beautifully ruffled and four generations of seedlings are rapidly coming on. Competent florists and seedsmen who have seen the plant in bloom pronounce it the most marvelous and striking gladiolus yet produced and the beginning of what will probably be the finest race of gladioli. There will probably be a few cut blooms shown at next year's Society of American Florists' Convention.

A. S. Kenderid

British Horticulture

THE NEW SWEET PEA ANNUAL

The fourth "annual" of the National Sweet Pea Society excels all previous issues in the variety and value of the matter presented. The book should be popular on both sides of the Atlantic for it is of a cosmopolitan character. An extract is given from Mr. Lester C. Morse's introduction to "Field notes on sweet peas," issued in San Francisco. "Mr. Burpee's Impressions" is the title of an interesting article from the pen of Mr. W. Atlee Burpee, who records some incidents of his last year's European tour. Referring to the activities of the National Sweet Pea Society Mr. Burpee writes: "There is a line of work that your Society has undertaken which I regard as most important, and which must be conducted with careful judgment. It is the prevention of the multiplicity of names of identical varieties. The Spencer type breaks so constantly that, of course, the same sports will be found in many different places. Personally I should much prefer that instead of giving new names to these Spencers we should give the name of the variety with which they are identical in color and add the word Spencer." The Society's annual report which has been circulated with the "annual" has the following paragraph: "One of the most pleasing and interesting features of the sweet pea year was the visit of Mr. W. Atlee Burpee, of Philadelphia, with his wife and family. Mr. Burpee visited most of the leading sweet pea growers in the United Kingdom; he was keenly interested in the splendid London show, which surprised him, and he was impressed by the extent and importance of the Society's trials. At the dinner given to the judges and officials at the conclusion of the show Mr. Burpee presided, filling the chair in the happiest possible manner, by his graciousness, bonhomie, and generosity. Mr. Burpee has presented the Society with a fine 15 guinea challenge cup for competition at the next show.

MUSHROOMS BY THE TON

Recently I paid a visit to the establishment of Mr. R. E. Addey, of Brentford, who is one of the leading mushroom growers and spawn makers. Although it was in the depth of winter, there were several houses in bearing, the total output being from a ton to 30 cwts. a week. As mushrooms make from 9 d. to 10 d. a pound on the market, it can readily be seen that this branch of commercial horticulture is a very profitable one, especially when conducted on the up-to-date lines adopted by Mr. Addey.

THE POMPONE CACTUS DAHLIA

At the autumn shows several nursery firms showed peony-flowered dahlias. These are simply open or pollen-centred specimens of the older sorts which have for many years been discarded by the English growers, but have been revived on the Continent. An English firm of dahlia growers is making a specialty of the pompone cactus section. From early August the plants were a blaze of bloom, and although one or two sorts soon failed to produce blooms full in the centre, there were several which continued to flower abundantly, yet remained good. These included Mignon, a lovely little pink-flowered cactus, Nain (deep chestnut color), Coronation (crimson), and Peace (white).

W. H. Adsett.

HORTICULTURE

VOL. VII FEBRUARY 8, 1908 NO. 6

PUBLISHED WEEKLY BY
HORTICULTURE PUBLISHING CO.
 11 Hamilton Place, Boston, Mass.

Telephone, Oxford 292
 WM. J. STEWART, Editor and Manager

SUBSCRIPTION PRICE
 One Year, in advance, \$1.00. To Foreign Countries, 2.00. To Canada, \$1.50
ADVERTISING RATES
 Per Inch, 30 inches to page \$1.00.
 Discounts on Contracts for consecutive insertions, as follows
 One month 4 times 5 per cent. three months 13 times 10 per cent.
 six months 25 times 20 per cent. one year (52 times) 30 per cent.
 Page and half page spaces, special rates on application.

Entered as second-class matter December 8, 1904, at the Post Office at Boston, Mass under the Act of Congress of March 3, 1879.

CONTENTS

	Page
FRONTISPIECE <i>Celsia Areturus</i>	
REFLECTED GLADIOLI—A. E. Kunder—Illustrated.....	165
BRITISH HORTICULTURE—W. H. Adsett.....	165
PAST AND PRESENT EXPERIENCE WITH MEALY BUG IN VINEKES—James Wheeler.....	167
THE FERTILIZING AND THE SELECTING OF THE CYCLAMEN—James Stuart.....	167
HIPPOPHAE RHAMNOLITES—D. A. Clarke.....	167
AFTER ADJOURNMENT.....	168
NATIONAL SOLDIERS' HOME, TOGETHER, ME.—Carroll Walker—Illustrated.....	168
AMERICAN CARNATION SOCIETY—The Convention, Story Concluded—The Banquet.....	169
NEWS OF THE CLUBS AND SOCIETIES:	
Alabama State Horticultural Society—The National Council of Horticulture—Tarrytown Horticultural Society—North Shore Horticultural Society—Florists' Club of Philadelphia—Secretaries for 1908.....	170
Club and Society Notes.....	174
Western New York Horticultural Society.....	176
WHAT THE GROWER SHOULD EXPECT FROM THE INTRODUCER OF A NEW SEEDLING—S. S. Skidelsky.....	171
SPECIAL POINTS ON CARNATION HYBRIDIZING—R. Witterstaetter.....	172
FLOWER MARKET REPORTS:	
Boston, Buffalo, Chicago, Detroit, New York, Philadelphia.....	181
OBITUARY:	
Andrew De Vo—Edward P. Stannard—John Awkland.....	188
MISCELLANEOUS:	
New England Conference on Rural Progress.....	169
Catalogues Received.....	174
Publications Received.....	174
<i>Celsia Areturus</i>	175
Incorporated.....	175
Personal.....	176
Philadelphia Notes.....	176
News Notes.....	178
Business Changes.....	179
New Retail Flower Stores.....	179
A Staunch House—Illustrated.....	189
Exempting Forest Lands from Taxation.....	189
Controlling the Coddling Moth.....	189
Missouri Botanical Garden.....	189
List of Patents.....	189
A Prosperous Path.....	190
Greenhouses—Building of Contemplated.....	190
New Heating Apparatus.....	190

The nomenclature of carnation sports—On the whole, we think the Carnation Society followed the wisest course in deciding against the advice of the nomenclature committee to give distinctive names to all sports without reference to the parent variety. One advantage which a sport carries with it is that, in the majority of cases,

its cultural requirements do not differ from those of the parent and that those growers who have grown the latter successfully can undertake the cultivation of the sport with greater confidence as to results than would be the case with a seedling. This point was not brought out in the discussion but it is an important one in that the retention of the name of the parent in the title by which the sport is known conveys directly to the purchaser this very useful knowledge as to its characteristics.

Again the charter—We understand that plans are being made to ask the Secretary of State, on behalf of the Society of American Florists and Ornamental Horticulturists, to extend an invitation to foreign exhibitors to participate in the National Flower Show at Chicago next November. Holding, as it does, a National Charter "for the development and advancement of floriculture and horticulture in all their branches, to increase and diffuse the knowledge thereof, and for kindred purposes in the interest of floriculture and horticulture" this organization can with the utmost propriety ask for this co-operation on the part of the National Government and favorable action on the part of the latter may reasonably be expected. That scolding query "What good is the charter" bids fair to be again answered in a most practical manner.

Essentials in hybridization—The best lesson to be learned from the plant-breeding discussions of the past week at Washington is the fundamental one that brains must be freely drawn upon if any success is to be expected in the production of new things. Indiscriminate guesswork is practically useless in hybridization. An intelligent purpose, intelligently followed, through methods intelligently chosen, is the only road worth traveling. And the paramount quality which must be retained and reinforced in every operation is stamina. Physique must stand first, for, if it is sacrificed in the least degree, eventual failure is a certainty. The history of plant hybridizing is strewn with the defunct relics of productions, beautiful and promising in every other respect, but deficient in this one essential. The weakling is doomed from the start.

A rose grower's duty—The next horticultural meeting of a national character will be that of the American Rose Society at Chicago, seven weeks hence. Secretary Hammond's appeal for a more general support of this useful organization by the rose growers and rose dealers throughout the country should call forth a spontaneous and hearty response. If every man to whom the queen of flowers has brought a comfortable livelihood should now take membership in this organization established to further promote their interests the American Rose Society would have no reason henceforth for anxiety as to the wherewithal for prosecuting its work on a scale commensurate with its importance. It is not creditable to florists or nurserymen that this Society should suffer for lack of interest or lack of funds. Both of these should be accorded to it with that liberality so characteristic of the horticultural profession when once it awakes to a realization of its duty.

Past and Present Experience with The Fertilizing and Selecting of Mealy Bug in Vineries the Cyclamen

When we read in the horticultural books and papers of all the things necessary to be done in theinery before starting the vines, such as clearing all the loose bark from the vines, scraping and rubbing them to make sure there is not a mealy bug's egg left, cleaning out the end of the spurs, which is a favorite place for them to crawl into, washing them with various insecticides and painting them with lime, sulphur, whale oil soap, and various other insecticides, and painting all the wood, brick and stone work with kerosene oil, raking and cleaning all the loose soil so as to make sure there is not a mealy bug or one of their eggs left anywhere in the house, and then after having followed directions scrupulously, what is more discouraging, after all one's vigilance and labor, than to see on the berries just set, a mealy bug? Your heart fails, for how well you remember what a splendid house of grapes there was last year—large bunches well colored and with beautiful bloom on them—perfect so far as growing went—but every bunch spoiled with the mealy bugs.

Nearly every grape grower has had this experience and a great many are still having it. I had it for years until three years ago I made up my mind to try cyanic acid gas. Knowing it to be death to all animal and insect life I found out all I could about the best way and the right quantity to use in my house which is a three-quarter span, 50 feet long by 12 feet wide, 12 feet high. About the 10th of November, 1904, I used five pounds of water, five pounds of sulphuric and 3 pounds of cyanide. It burned the leaves that were left on the vines but did not hurt the vines. During 1905 I found only three mealy bugs. I did not do a thing to the vines in any way, only washed the glass and woodwork to clean it.

In November, 1905, I used 2 1/2 pounds of cyanide. During 1906 I found mealy bugs over where I had placed some plants. In November, 1906, I used three pounds as at first. Last year, 1907, we did not find a bug; the bunches and berries were larger and better than I have had in that house for years. Last November they had three pounds more. Since 1903 we have not cleaned the vines in any way whatever. I believe it is very injurious to vines to strip the bark from them; many buds are knocked off and some killed by too strong a wash.

By using the cyanic acid gas you kill every insect and egg, save lots of unnecessary labor and when the grapes are ripe it is such a pleasure to cut them and have them put on the table in perfect condition.

James Wheeler

We read with interest in last week's HORTICULTURE Mr. Brown's article on the cyclamens at Sandringham. We are certain the illustration does not do them half justice. Did anyone ever see a photograph of cyclamens that did them anything like justice? We would have wished, however, that Mr. Brown had gone a little more into detail regarding the method of fertilizing at Sandringham, which he says was most interesting and worthy of emulation by growers here.

The illustration shows a house of mixed colors. We would like to learn if the fertilizing was done in a house of mixed colors, or are there several houses devoted to cyclamens at Sandringham, and the colors kept separate for fertilizing?

It has been our experience in fertilizing cyclamens in a house of all colors, open to the influence of insects, that in a few years the colors seemed to all get mixed—more especially so with the pinks and reds. The same result as to color came from selection of seed from good flowers; the size of the flower, foliage and stem might be retained and a little improved but not so the color.

We have always been able to procure a good strain from a reliable source although there are many poor strains on the market, and we are still of the opinion that good culture helps greatly in bringing out the rich qualities of a strain of cyclamens. So finally we gave up the fertilizing and selecting, believing there were no permanent results gained, working as we had to do on a limited scale.

James Stuart

Mamaroneck, N. Y.

Hippophae Rhamnoides, Linn

Now that attractive winter fruit is so generally recognized to be a valuable asset of an ornamental shrub it may be well to call attention to the Sea Buckthorn, a plant native to Europe and Asia. Normally it is a large shrub eight to ten feet in height, although occasionally it becomes a low tree with a height of twenty feet. Not infrequently it is somewhat straggling in habit and seldom is it really symmetrical. Its branches are numerous and irregular. The foliage is willow-like and of a silvery gray color. The flowers which appear in May are small, yellowish and of little worth. However, this is not true of the fruit which follows. This is berry-like and borne in the greatest profusion by the female plant. It ripens in late September or early October and retains its showy orange color until mid winter or even until early spring. As the plants are dioecious it is essential to have male plants near. Although rather naturally a seaside plant thriving in sandy soil and exposed situations, it does admirably inland unless the soil be very clayey. It increases by suckers and occasionally may become somewhat troublesome. Otherwise it is easily grown and managed.

Hippophae rhamnoides is figured and described in "The Garden" for Feb. 27, 1904.

Daniel A. Clarke.

AFTER ADJOURNMENT.

What is it? "Hydrangea Arborescens Alba Grandiflora" figured in Good & Reese's catalogue with cordate foliage and broad, nattered corymbs of flower, while in Dingee & Conard's catalogue we find "Hydrangea Arborescens Var. Sterilis" bearing oblong ovate leaves and conical panicles of bloom! Confusion again and no "Registrar" to cause!

That was a very nice compliment which President Roosevelt paid the Carnation Society on the occasion of their visit to the White House when he congratulated the members on having brought their ladies. Each visitor wore a carnation and the contrast between the appearance of this body and that of another organization, which at the time was standing in line, carnationless and ladyless, for a reception arranged to follow after the Carnation Society, was quite marked.

An anonymous correspondent is one of the most contemptible creatures which the world has ever produced. Outside of the prisoner, he adopts the most cowardly way of attacking people.

He does not give any one a fair chance to defend himself, but remains hidden in the recesses of obscurity to protect his own reputation. Such a sneak may even call to see the person whom he has defamed, appear friendly and at the same time study the effect of his wickedness upon his unsuspecting victim.

No matter how one may view the work of an anonymous communicator he must come to the conclusion that a devil seems more like a saint than such a fellow, and he can readily imagine that old Beelzebub would not allow a nameless letter writer to enter hell for fear of making the infernal abode worse. N. Y. Evening Telegram Correspondent.

In the words of Jethro Bass: "Hain't underdone it, and hain't overdone it a mite, hev you? Callate you couldn't hev beat that if you was to take a week to it."

John Cook's red rose Cardinal is a favorite with Poehlmann Bros., Chicago. Now that its merits have been discovered by this wideawake firm, no doubt this fine American rose will find admirers a-plenty. Another of Mr. Cook's roses, the pink Enchanter, is held by Gude Bros. of Washington to be in the very front row.

At present writing, the daily reporters' pets, the suburbanite with the dandelion blossoms and the lady with the pansy from the back yard, have subsided, and the outside thermometer with frozen bulb looks wistfully through the glass at his comfortable brother inside the greenhouse. Even in ideal Minneapolis, two weeks ago, they were boasting of the tulips blooming amid summer zephyrs and "the bees a-humming soft and lazy, January are you crazy," etc. Better to stick to the greenhouse man in the long run, when it comes to getting flowers in mid-winter, Mr. Reporter.

Speaking of carnations, which do you find is best appreciated by the average flower buyer with moderate purse—a good bloom of an obscure or nameless variety, or a poor bloom of the most handed pet of the exhibition, at same price?

Mr. Ward's avowed present aim in carnation improvement to purify and

NATIONAL SOLDIERS' HOME, TOGUS, ME.

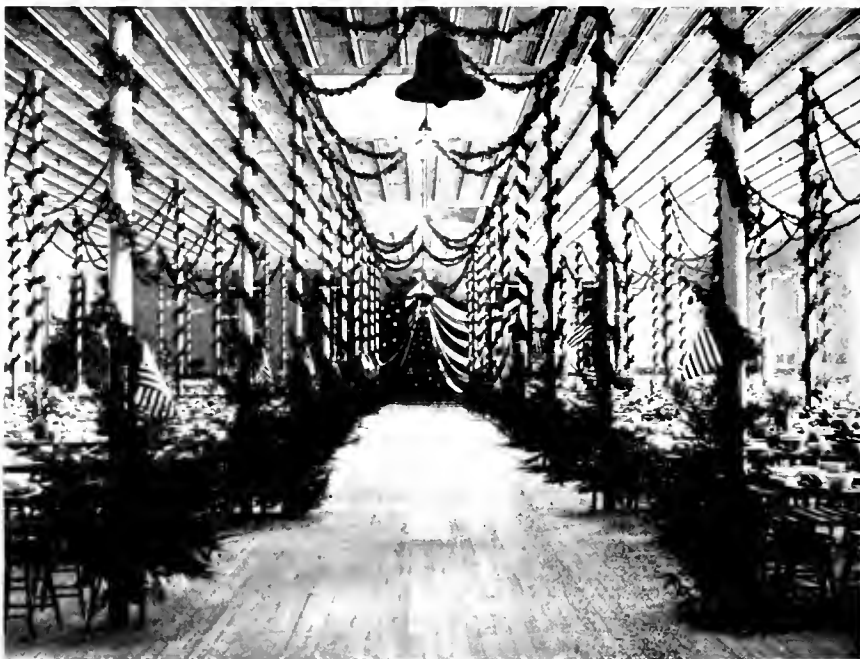

Happening in the vicinity of Togus the other day, I decided to call on my friend Mr. A. W. McIntosh, chief of the Horticultural Department, and also get a look at the holiday decorations. These were more elaborate than anything of the kind in the history of the home, and attracted crowds of visitors. The Governor's quarters, chapel, various mess rooms and hospital all had their share of attention. The chapel was simply but tastefully trimmed with evergreen wreathing, holly and poinsettias, and with handsome memorial wreaths in each window. The hospital dining room was more pretentiously dressed, and a large Christmas bell hung in the centre of the hall imparted a seasonable suggestion to the work. The "piece de resistance, however, was the large mess hall, in which 2500 men are fed three times a day. Each of the 60 columns, 19 ft. in height, supporting the ceiling, had been closely twined with roping, and in addition a specimen spruce tree six feet high and surmounted by an American flag was attached to the front of each of the ten columns on either side of the main aisle. Christmas bells were suspended at intervals above this aisle, and, at the further end, the national colors were draped against the wall, crowned with a 49-inch star illuminated by electricity. Directly in front of the flag stood a magnificent fir tree, twelve feet high, and covered from top to bottom with red, white and blue electric lights, and poinsettias. The ceiling was a perfect maze of loops and festoons of evergreen, the

intensity color tones so that they may be more brilliant, delicate or pleasing to the eye, will be generally accepted as the work on right lines. If it be true as regards the carnation how much more does it apply to the chrysanthemum? Most critics will agree

walls scrolled with wild smilax and the doors and windows all beautifully outlined. I noted that leucothoe sprays were used largely in this part of the work. The windows were further dressed with wreaths of evergreen and holly, and each of the forty large dining tables was arranged with dracenas and stevias, the latter being the best specimens for the purpose the writer has ever seen. All the decorations were carefully planned by Mr. McIntosh weeks ahead, and every detail carried out under his personal supervision; over 3000 yards of roping were used, all made by inmates of the home and employed in the green houses.

A walk through the houses showed everything up to date, and no waste room. There is promise of abundant bedding stock for 1908, except alternanthera, which Mr. McIntosh regards as unsuited to present conditions at Togus. Thousands of tulips, hyacinths and other forcing stock are in their various stages. A house of roses, seventy days planted from 2-in. pots, look like six months, a fine lot of tomatoes were well along to maturity, and a batch of string beans in 6-in. pots looked good enough to eat. Should it be acceptable to you, I may later on give your readers some further items regarding what has been accomplished for the improvement of the grounds, since Mr. McIntosh took charge last April, and also something of what is projected for the future development of this beautiful government reservation.

CAMPBELL WALKER.

Kennebunk, Me.

The above interesting letter should have appeared at holiday time but was crowded out for the time being. Ed.)

that size and form may safely be left at their present stage for a time, while the chrysanthemum experts devote their energies and ingenuity to the task of purifying and brightening up the prevalent colors in the queen of autumn.

AMERICAN CARNATION SOCIETY.

The Convention Story Concluded.

On Wednesday evening after the reading of S. S. Skidelsky's paper on what the grower should expect from the introducer of a new seedling, Fred Burki took the floor and contributed some pertinent views on this subject. He claimed that because of the different conditions of soil and environment which a variety must meet after leaving the introducer, the latter could not be fairly held responsible for the behavior of a variety after dissemination. F. R. Pierson argued that honesty and a candid understanding between disseminator and buyer is at all times the best policy. He took the ground that medium-sized varieties are entitled to more attention than has been accorded them by the Society. He favored indoor culture and asserted that the buyer of a novelty should be willing to assume some responsibility.

W. N. Rudd, who was scheduled to say something on what the introducer should expect from the growers, advanced the opinion that the introducer of a novelty is lucky if allowed to live. "If the buyer will pay his bill, that's all we ask of him." Fair dealing, he said, should be the basis of all transactions. The introducer has a right to expect that the buyer will treat the cuttings right. The introducer should be given credit for honesty, and not be compelled to prove himself not guilty. There are very few instances, he said, where a man has started out with a purpose to swindle in the introduction of new carnations, and charity should be exercised in all cases of dissatisfaction. F. R. Pierson followed, referring to the great work which the introducers have accomplished and the lack of appreciation. The habit of unfavorable reflection upon the introducer and implied censure of his honesty was not justified by the facts.

The previous announcement that the flowers on exhibition would be distributed to the public on Wednesday evening brought a large and expectant crowd, mainly ladies, to the hall, and when the signal was given it did not take long to divest the tables of every vestige of the great carnation show. The fun-maker could not resist the temptation which the situation afforded, and announcement was gravely made from one of the tables that potted plants would now be given away in the upper hall. A wild stampede up the stairs to the hall where the Carnation Society's meeting was in progress followed, and the resultant confusion on the one side and hilarity on the other filled the fun-makers' hearts with comfort and joy.

The Banquet.

The banquet given by the Florists' Club of Washington on Thursday evening, January 30, to the American Carnation Society and ladies was, as briefly mentioned in our issue of last week, an occasion long to be remem-

bered. After President Bisset had voiced the welcome of the local club to the visitors, the first toast, "Our Country and President," was responded to by Hon. Wm. E. Andrews, Auditor U. S. Treasury. He applauded the presence of handsome women and beautiful flowers and followed with a speech overflowing with patriotism, flag and country. It was a stirring address and evoked enthusiastic applause.

The next toast, "The American Carnation Society," was responded to by President Fred. Lemon. He said that the subject was one close to his heart. He referred pleasantly to the international character of the membership and to the beneficent work being accomplished by the society. He closed with a good word for his successor and the place of meeting for next year. President-elect Patten, who followed, was given a rousing reception and made an elegant little speech. J. H. Dunlop, on behalf of the Canadians present, also spoke appreciatively and was accorded great applause.

The next toast, "Washington, Our Capital," was assigned to Hon. Robert N. Harper, President of the Washington Chamber of Commerce. Mr. Harper kept his audience in glee with anecdotes and claimed that Washington is destined to take a leading place in the commercial world as it has already done in other respects. He enlarged upon its agricultural, manufacturing and transportation facilities and magnificent opportunities for trade development, and recalled the fact that in the recent financial disturbances it was undisturbed. Professor Taylor then contributed some capital recitations, receiving several recalls.

Prof. David G. Fairchild next responded for the Agricultural Department. He told of some of the work accomplished and forecast the plans of the future. With an army of over 9000 employes—young men full of enthusiasm and vigor—it is working out ideas for the benefit of the horticultural profession and the American people.

"Horticulture" was the toast assigned to Robert Craig. He made kindly reference to the journal published under that name, the selection of which title he characterized as reaching the very highest apex. With characteristic eloquence he then spoke of the glories of the Garden of Eden, of horticulture as the greatest of all arts, which is keeping pace with the progress of the world on all lines. He paid a fine tribute to the "Grand Old Man of Horticulture," who has presided over the Botanic Garden with such skill for so many years, the value of whose work we can hardly realize. He also referred to the enthusiasm and the splendid record of the American

Carnation Society in its twenty years' existence.

"The Horticultural Press" was the next toast and Wm. J. Stewart responded. He spoke of the birth and growth of this most important ally of the horticultural profession within the past quarter of a century and presented its claims for the support and affections of everyone making horticulture his life work. There is no agency so indispensable today and none that gives so much return for so small a cost. On behalf of the New England members of the Carnation Society he expressed the happiness all felt in contemplation of the fact that New England had been honored by the selection of one of her sons, one whom everybody loved and who was well worthy to be the standard bearer of the Society for the coming year.

Wm. F. Gude then responded to the toast "Our Guests." His speech was full of genial cordiality and well-expressed the hospitable feelings of the Washington brethren.

"The Ladies," the last toast on the program, was ably handled by C. W. Ward after the toastmaster had given a most poetic introduction. Mr. Ward enlarged upon the charms of beautiful character, which far outshone physical attractiveness, and proved himself an eloquent exponent of this ever-delightful theme.

The closing exercises included the presentation of the cups, medals and other trophies of the exhibition to the fortunate winners.

NEW ENGLAND CONFERENCE ON RURAL PROGRESS.

The second annual New England Conference on Rural Progress will be held in Boston, at the office of the Secretary of the State Board of Agriculture, on Friday, March 5, 1908. The success of the meeting of last year seems to have demonstrated the value of this conference. It is hoped that representatives of all the important rural associations in New England will send delegates.

The general subject of the conference will be "The Teaching of Agriculture in the Public Schools." This is a most opportune theme and will be treated by experts who will take up a thorough discussion of elementary agriculture as a subject of study in the grades, the place of secondary agriculture in the public high school, separate schools of agriculture and federal aid to the teaching of agriculture.

KENYON L. BUTTERFIELD.

Amherst, Mass.

Enclosed find \$1.00 for which please send me HORTICULTURE for one year as it is just what I have been looking for and fills the bill.

M. G. A.

Morristown, N. J., Jan. 2, 1908.

NEWS OF THE CLUBS AND SOCIETIES.

ALABAMA STATE HORTICULTURAL SOCIETY.

The fifth annual meeting will be held at Birmingham, Alabama, Thursday and Friday, February 13 and 14, 1908, at the rooms of the Commercial Club. All persons interested in horticulture are cordially invited to attend. The program is as follows:

Opening exercises Thursday, 1:30 p. m.; Address by President W. F. Heikes, Huntsville; History of Fruit Growing in Alabama, Dr. P. J. Beckmans, Georgia; Montgomery Flower Growers' Association, Mrs. W. A. Gayle, Montgomery; Address by Prof. Samuel B. Green, President Minnesota Horticultural Society, St. Paul; School Improvement, Mrs. L. H. Craighead, Mobile; Improving our Country Homes, Dr. W. S. McCain, Livingston; Relation of Horticulture to the Schools of the State, Prof. S. L. Chestnut, Montevallo; How to Reduce the Fertilizer Bill: Some Truths about Seeds, Mr. C. B. McVay, Birmingham; Address by Hon. J. A. Wilkinson, Montgomery; Results and Significance of the Plant Disease Survey in Alabama, Dr. E. Mead Wilcox, Auburn; Laboratory Methods of Studying Plant Diseases, Prof. Stone, Auburn; Cowpeas, Prof. J. O. Sargent, Hamilton; How to Set Out a Young Orchard, Prof. E. F. Candern, Wetumpka; Fertilizers, Mr. C. H. Billingsley, Montgomery; Fruit Growing in the South, Mr. D. C. Turnipseed, Flora; Notes, Mr. Herbert Chase, Huntsville; Fruit Insects, Dr. W. E. Hinds, Auburn; Notes on Fruit Growing in the West, Mr. M. C. Scott, Montgomery; Fruit Soils, Prof. W. C. Smith, Montgomery; Forestry, Hon. J. B. Powell, Montgomery; Best Way to Sell Trees, Mr. A. G. Long, Andalusia; Cantaloupe Culture, Mr. H. L. Trott, Montgomery; Our Work at Lapine, Mr. C. W. Landers, Home Fruit Growing, Mr. J. A. Kermode, Camp Hill; Notes, Prof. R. S. Mackintosh, Auburn; Report of Committees; Business; Reports of Vice-Presidents.

Program will probably not be followed as given above.

NATIONAL COUNCIL OF HORTICULTURE.

A meeting of the National Council of Horticulture was held at the Auditorium Annex, Chicago, on January 22. Prof. R. S. Mackintosh, Auburn, Ala.; W. T. Macom, Ottawa; Prof. E. J. Wickson, Berkeley, Cal., were elected delegates. Plans for the Press Bureau service included the use of sixty-eight articles for a period of seventeen weeks, an expenditure of \$75 for the preparation of fifty articles to be sent to about 500 newspapers and syndicates. The secretary reported \$114.28 on hand with a promise of \$550 from interested societies. Letters were read from L. Horace McFarland suggesting an effort to encourage improvement of planting conditions about country schools, and L. W. Fitch, secretary of the Wisconsin Cranberry Growers' Association, suggesting articles on cranberries as an article of diet. The secretary was instructed to offer to use four such articles at an approximate cost of \$25.

TARRYTOWN HORTICULTURAL SOCIETY.

The Tarrytown Horticultural Society held its regular monthly meeting in Good Templars' Hall, Friday evening, Jan. 31st, 1908, Vice-President Angus in the chair and a large attendance of members. Several communications were read from friends regretting their inability to be present at our last dinner; and an invitation was also read from the New Jersey Floricultural Society to attend their annual Smoker on Feb. 7th, 1908.

As it was carnation night and as Treasurer J. T. Lawrie had offered a prize for the best 18 blooms of three varieties, six of each, a very fine display of flowers was in evidence. First prize was awarded to Samuel Untermyer (Gard. W. H. Waite), Yonkers, N. Y., for Winsor, Enchantress and White Enchantress. Second prize was awarded to Geo. Legg (Gard. J. Elliott), Tarrytown, N. Y., for White Enchantress, Miss H. M. Gould and Mrs. M. A. Patten.

F. R. Pierson Co. had for display only, a very fine lot which was awarded honorable mention; the varieties were White Perfection, Red Chief, Victory, Melody, Beacon, Winsor, Rose Pink, Enchantress, White Enchantress, Var. Lawson and Mrs. M. A. Patten. Honorable mention went to Scott Bros., Elmsford Nursery, for ten vases of Beacon and Miss H. M. Gould. A cultural certificate was also awarded to Mr. Waite for a very finely grown vase of May's Giant Mignonette. Quite a lengthy discussion followed on carnation culture, viz., cutting, method of striking, temperature, growing ready for the field and indoor culture, and all listened with pleasure to the interesting remarks of F. R. Pierson, Wm. Scott, D. McFarlane and John Woodcock. The most entertaining feature of the evening was the brief account of visits by F. R. Pierson to several growers in different parts of the country, also his attendance on the convention of the American Carnation Society at Washington, its great exhibition, great banquet and reception.

LOUIS A. MARTIN,
Cor. Sec'y.

NORTH SHORE HORTICULTURAL SOCIETY.

The ninth annual banquet of this prosperous society was held at Manchester, Mass., on Wednesday evening, January 29, and is recorded as one of the most successful in the society's history, from every point of view. The tables were handsomely decorated with flowers and the walls screened with pine and laurel. A fine group of palms screened the orchestra on the stage. Two hundred and nineteen guests were present, including several from Boston. President Till acted as toastmaster. Among the speakers were D. I. Bingham, 95 years old; Rev. W. F. Powers, J. K. M. L. Farquhar, J. W. Duncan, Rev. L. H. Ruge and E. H. Brewster.

FLORIST CLUB OF PHILADELPHIA.

Carnations, sweet peas, and Queen Beatrice roses divided honors with E. A. Harvey at the monthly meeting held the 11th inst. Mr. Harvey proved an ideal essayist, giving his views in practical, commonsense form and with admirable and commendable brevity. This is Mr. Harvey's first appearance here and the fact of his having already acquired the rare and radiant secret of how to boil it down enshrines him to the thirty-third degree in the hearts of a hustling, get-there community. Along with his talk Mr. Harvey gave concrete evidence of his ability as a carnation grower by exhibiting nine vases of magnificent blooms, among them being Aristocrat, White Perfection, Victory, Winsor, Lawson, Robert Craig and Enchantress. He also exhibited a new white seedling carnation, raised by E. C. Marshall of Kennett Square, and a vase of the new pink forcing sweet pea, Mrs. William Sim. The latter is a strong grower of pleasing light pink, a shade brighter than Daybreak carnation. It has fine long stems and is about two weeks later than the well-known Pink Christmas variety. The Strafford Flower Farms sent a fine lot of Enchantress, Beacon, Lady Bountiful and Winsor. Also a vase of a new carnation from Guernsey, England, Mrs. W. H. Burnett, a light pink, finely formed, good substance, a little under-sized but thought by Mr. Stroud to be valuable as a spring and summer variety. Joseph Beacock exhibited new pink seedling No. 100, fresh from its blushing honors at Washington. A grand vase of Queen Beatrice came from F. H. Kramer. We have never seen better flowers of this beautiful variety. Samuel Batchelor staged White Enchantress, Lady Bountiful and a new pink sport from Lawson. Also two pots of white cyclamen with very large flowers of the grandiflorum type and showing high culture. The Henry A. Dreer nurseries exhibited Clematis indivisa which was quite a revelation to many. It was stated that it had proved very useful as a florist's decorative plant, the sprays being freely produced during February, March and April. One florist who bought two plants found it so good the first year that he followed up with an order for fifty the next season. This variety is a native of New Zealand and is but little known here, although introduced in 1847, being only half hardy. Thrives well in about the temperature of an ordinary carnation house. Closely allied to C. montana, flowers white, and 1 1/2 inches in diameter, produced in large clusters like C. paniculata, leaves evergreen.

SECRETARIES FOR 1908.

The New Jersey Horticultural Society; H. G. Taylor of Riverton.

The Forest Grove Horticultural Society, Oregon; Harry Paynes, Forest Grove.

North Dakota Horticultural Society; Prof. Thompson, Bottineau.

WHAT THE GROWER SHOULD EXPECT FROM THE INTRODUCER OF A NEW SEEDLING.

By S. S. Skidelsky; read before the Carnation Society at Washington.

It would be hard to find in the history of floriculture another instance of the rapid strides and development of a flower to equal that of the carnation.

The divine flower has indeed sprung into favor as if by magic wand. Unlike the short-lived chrysanthemum or the queen herself—the rose—the carnation is pre-eminently the flower of the masses. It is grown everywhere, it is sold everywhere, the "curb merchant" no less than the society florist handling it in immense quantities. More glass is going up, more carnations are being grown, and the demand continually is for still more. Nor is its popularity confined to our own borders. England, Germany and France depend upon our varieties; far-away Norway and Sweden grow them with success; and even darkest Russia, we are told, can do Lawson, Enchantress and White Perfection well. Let us hope—and you will pardon my slight digression from the subject—that with the advent of Beacon there may come a light to brighten the hovels of the semi-civilized, wretched peasantry in the Czar's domain.

A Prediction Verified.

When John Thorpe, but a comparatively short time ago, predicted that our puny carnation of yesterday would attain the respectable size, by actual measurement of four inches in diameter, there are many among us today who were inclined at the time to treat such prophecy with a four-inch grain of salt. That prediction of Mr. Thorpe's has come true, nevertheless. We have practically reached the goal of our ambition. The four-inch carnation is here, and has evidently come to stay. Nor are we content to rest upon the laurels achieved. We are aiming higher and still higher. What was good enough a season or two ago, does not satisfy us today. We must have something better. It won't do to stay the march of progress or to check the course of evolution. Aside from the size of the bloom itself, we must have also stem—a long and stiff one at that. We must have a carnation with a non-bursting calyx, of good color, good keeping qualities, and last but by no means the least, we insist on varieties that will produce the flowers and yield us dollars and cents—"bread and butter" carnations, if I may borrow the stereotyped description, now and then applied to seedlings which do not pay for the bread, let alone the butter.

It is not my intention, however, to point out any particular varieties, nor do I wish to call to the bar of the grower's opinion any of the introducers of the "bread and butter" sorts, the kinds that never paid for either the bread or the butter.

The Origin of "Worthless Varieties."

I am rather inclined to the belief that the average introducer of a new seedling is honest and honorable; that

he means well; that his sole aim and object in introducing a carnation is to give satisfaction; that under all circumstances he aims to give the grower his money's worth. There have been some exceptions, of course, but this is another story, having no bearing upon the subject under consideration. Granted then that no fraud or deception on the part of the introducer is ever intended, the question arises, Why are worthless varieties thrown upon the market? Why indeed?

I shall attempt to answer this question, as I have studied it at close range, depending upon my personal impressions and observations, which, of course, are in no wise infallible. My observations upon numerous occasions lead me to the conclusion that there are some hybridisers who are inclined to be too optimistic, often being carried away, so to speak, by the momentum of their own enthusiasm. The man thus inclined makes his cross, selecting for the purpose sturdy and meritorious parents. The result, he takes it for granted, must be highly satisfactory. I say "he takes it for granted" advisedly, because taking things for granted is a characteristic trait of the enthusiast. He watches the seed pod with all the care, hope and love which a young mother bestows upon her first born. To be sure, he reasons, something good must result. A chip of the old block is an asset not to be despised. In course of time the seedling or seedlings appear. Out of a dozen or more "uncertainties" the one looking the most promising is selected and duly labeled. No sooner does the bloom break through the calyx than the plant is chopped down, literally hocked to pieces, in order to get all the cuttings, good, bad and indifferent, that it may yield through and beyond the season. The vitality of the "promising one" is thus impaired at the very outset of its ephemeral career. The season following it still looks promising, although the calyx is somewhat inclined to go asunder, nor is the stem strong enough to sustain the weight of the bloom or the bunch of petals. The season, of course, which happened to be either too dry or too wet, is accountable for that. Perhaps a little overfeeding did the mischief; maybe a degree or two below or above the temperature required to suit its delicate constitution. To be sure there are numerous reasons for its misbehavior, but no matter, where there is life there is hope. A second massacre is in order and the plants are propagated to the limit. Cuttings are taken regardless of their condition. It won't do to "put off" when the growers are so much in need of a good White, a good Red or a good Pink, and, incidentally, when there is a fortune in sight. I will stop right here, however, to reiterate my assertion that the introducers of new carnations are absolutely honest; that no fraud is intended when a carnation is finally launched with all the pomp and all the songs in its praise which we are accustomed to see and to hear.

Not How Many, But How Few.

The question what the grower should expect from the introducer of a new carnation is rather a perplexing one, and is not so easily answered as one might expect. Our ideas of the

fitness of things are so much at variance with local conditions and local requirements that it would be practically impossible to set up a standard with a view to insuring general satisfaction.

In one of the November issues of HORTICULTURE Mr. John Thorpe, in his notes on the Chicago flower show, has this to say about the carnations which were on exhibition there: "Of new carnations—in quantity very short, in quality never better. Raisers of seedlings are getting wise. It is not how many, but how few. Let this prevail, because the few have the best chance." Tersely expressed, but true. That the few of superior quality have the best chance is not to be denied. Yet, on the other hand, we must also not ignore the fact that while there are comparatively few growers ever in quest of "fancies" or carnations of quality, whose products are sure to command the highest prices at all times, there are hundreds and thousands of others who are ever on the lookout for "the bread and butter sorts," whose local markets, either wholesale or retail, do not warrant heavy investments in "fancies," who, in brief, must have carnations which, taking local conditions into consideration, will pay for the coal, the help, the interest on the greenhouse plant, and will leave a dollar to boot. It is the rank and file that is to be considered; the man who can no longer grow Lawson or Queen, who is in want of something to take their places. A standard, therefore, to suit alike the successful growers in the vicinity of New York or Chicago and the man in the Dakotas, is not to be thought of.

But what, after all, is the grower to expect from the introducer of new seedling carnations?

That Happy Middle Ground.

Coming to the point by the shortest possible route, it begins to dawn upon me that there ought to be a sort of happy middle ground, upon which both the grower and the hybridizer could meet for the purpose of advancing their mutual interests, for the purpose of adjusting differences, of overcoming prejudices and of facing conditions. If the one realizes the need of the other; in other words, if the introducer of seedling carnations will exercise the most scrupulous care in behalf of the "goose that lays the golden egg," and the grower in his turn will bear in mind that his very success or the "golden egg" has been made possible by the men who have made hybridization their life study, who are sacrificing their time and their means in order to improve upon past achievements and thereby advance the interests of the carnation growers,—if both, I say, could meet upon such ground, there surely would be no cause for disappointment or dissatisfaction. But how is this to be accomplished? Leaving the hybridizers' cause in the hands of Mr. Rudd, who, I am sure, will do ample justice to it, I will take up the growers' end of the question and will briefly outline his expectations from the introducers of new seedlings.

The Grower Expects His Money's Worth.

First. The grower expects his money's worth. By this I mean that

when he orders a batch of high-priced cuttings he expects and is fully entitled to high-grade stock cuttings that have been carefully selected and well rooted—rooted not by dirt of the steam pipe at so many thousands per week, but by the natural process of keeping the feet comfortably warm and the heads cool, to insure vigor and health.

Second, He expects from the variety just what it is represented to be. In other words, when a variety is a cropper, it should not be represented as a continuous bloomer, that when its calyx splits at certain seasons or under certain conditions, that fact should be brought to the surface regardless of losses or gains.

Third, He expects the benefit of the introducer's experience without paying an additional price, often a heavy one, for the experience himself. By this I mean, that when a seedling has been thoroughly tested and its requirements and peculiarities studied and recorded, the introducer is morally obliged to give the grower the benefit of his own knowledge and experience. The grower is entitled to such information and it should not be withheld from him. A printed slip, bearing all the cultural notes about the variety introduced, should accompany each and every shipment. And

Fourth, The grower expects a "square deal." By this I mean that no carnation, no matter what its previous record, no matter how many points it scored or how many medals were awarded it—unless it maintains its record in all the essentials up to the time and including the season of its dissemination, unless its vigor is in no wise impaired, should see the light of day. The introducer must be absolutely certain on this point, he must take nothing for granted, else the grower is sure to be a very much disappointed man.

No More "Gold Bricks."

The growers' expectations, it seems to me are within the bounds of reason and need hardly be dwelt upon at greater length here. Let a condition of a thorough understanding and most scrupulous honesty on both sides prevail and we will no longer hear about "gold bricks" and "suckers."

After all there is a deal of truth in the old saw of honesty being the best policy. The most successful business men of today are those who pursue such a policy, whether it be in the dissemination of seedlings or breadstuffs. The child that burns its fingers fears the fire, so does the grower steer clear of the man who sells him a winner and gives him a "gold brick" instead. It is to our own interests, whether we are hybridisers, dealers or mere agents, to discourage worthless varieties, stamp them out—root, branch and all—if we wish to see the most important branch of our business thrive and develop without hitch or hindrance.

Please find inclosed \$1.00 for a year's subscription to HORTICULTURE. I find HORTICULTURE a paper which I could not be without. Wishing you success, I remain

Yours respectfully,

HARRY DIETZ.

Indianapolis, Ind., Dec. 31, 1907.

SPECIAL POINTS ON CARNATION HYBRIDIZING.

Read before the Carnation Society at Washington, by R. Witterstaetter.

Mr. President, Ladies and Gentlemen: Some sixteen years ago, when I first undertook the work of hybridizing the carnation, I had very little knowledge of Nature's law regarding the results to be expected from crossing the standard commercial varieties of that date; and concluded that experiments with a complete record of the percentage and the results was necessary. As regards color, size, stem, form, habit, freedom, etc., I found while we had some very good seedlings that pointed up well in everything except color, and color being a very important factor in a commercial carnation, that we got quite a few variegated purples and off colors, and very few identical to the parent color. I, therefore, concluded that it must be Nature's law in plant life the same as in the human race, and first blood would tell and future breeding has been carried on with that point in view, namely, scarlets in a race by themselves, white in theirs; and so on, always selecting for future work that which came nearest to an ideal as to color and commercial value.

Some have held that by following this method you lose constitution. We have proven this, to our own satisfaction, to be untrue if a selecting of vigorous parents is made for the work. This opinion may have arisen from the fact that a very brilliant scarlet has no vigor to back it up, our most vigorous scarlets being only a fair or dull red; and if a good constitution and a brilliant color are combined, the result is apt to be a slow and shy bloomer, not up to the commercial requirements. As most of my endeavors have been devoted to the scarlet race—amounting to about one-third of the number of seedlings raised—I have taken the pessimistic view, that it would be an impossibility to produce a brilliant scarlet of free blooming quality, backed up by a vigorous constitution. Of late years, however, I have observed that this will not be an impossibility.

In breeding for form we have always selected those that have reproduced themselves in that point for two or three generations, from one or the other of its parents, preferably the seed parent, and using the same as a seed parent. In pink we do not hold so closely to the color line, but are very particular that whatever color is used be of good, clear, strong and lively tone, not subject to fading into dull colors, or easily affected by the sun.

In breeding for size, we do not hesitate to use a small flowered variety as to a seed parent, provided its progenitors of the first and second generations past were large flowered varieties; as a pollen parent likewise, if it has all the other attributes of a good commercial variety.

In breeding for stem and calyx, I like to select a variety that has inherited these good points from one or two generations past, with the bloom bordering on the semi-double, or not too many petals to insure a good setting of seeds; also guarding against parents with flowers containing too

Rooted Carnation Cuttings

<u>Pink</u>	100	1000
Aristocrat.....	\$6.00	\$50.00
Winsor.....	6.00	50.00
Rose Pink Enchantress.....	3.50	30.00
Enchantress.....	3.00	25.00
Lawson.....	2.50	20.00
Joost.....	2.00	15.00

White

White Perfection.....	3.00	25.00
" Lawson.....	3.00	25.00
Queen.....	2.00	18.00
Boston Market.....	2.00	18.00
Louise.....	2.00	18.00
Lt. Peary.....	3.00	25.00
Bountiful.....	2.50	20.00

Red

Beacon.....	6.00	50.00
Victory.....	3.00	25.00
Robert Craig.....	3.00	25.00
Flamingo.....	2.50	20.00

Miscellaneous

Patten.....	2.50	20.00
Harry Fenn.....	2.50	20.00
Harlowarden.....	2.50	20.00

Stock Guaranteed—Prompt Deliveries

THE LEO NIESSEN CO.
WHOLESALE FLORISTS
1209 Arch St., PHILADELPHIA

LLOYD IS THE REAL THING

The Carnation for every one to grow

LLOYD is a commercial white, with a fancy flower

The only ever-blooming, large-flowering white in existence

Will take the place of all other whites now in commerce. Every New Bedford grower has bought stock. Come and investigate.

**A KEEPER
A SHIPPER
A BLOOMER**

It will bring the shekels when all others fail

\$2 pr 12. \$12 pr 100. \$100 pr 1000

**Unrooted Cuttings
\$6 per 100. \$50 per 1000.**

H. A. JAHN

NEW BEDFORD, - - MASS.

WHITE FAIR MAID

Rooted Cuttings

\$10 per 100. \$75 per 1000
WELCH BROS., 226 Devonshire St.
Boston, Mass.

Winsor and White Enchantress

**Strong Rooted Cuttings
Now Ready for Delivery**

WINSOR has proved to be the finest carnation in the light pink class. We sold a large quantity of it last year, but there will be a much larger sale for it this year. At the English Carnation Show held in December, it was the winner in the light pink class. It is doing well everywhere and will supplant everything in that color.

WHITE ENCHANTRESS will occupy the same position among white carnations that Enchantress does among flesh pinks. It has all the good qualities of the common Enchantress,—long stem, earliness, large size, freedom, etc. In our opinion, it is by far the best white carnation ever introduced.

We have a splendid stock of both Winsor and White Enchantress ready for immediate delivery, and will guarantee perfect satisfaction with the cuttings supplied. Do not wait, because the demand for these varieties is bound to be enormous. **Order early, while we can promise immediate delivery,** and secure gilt-edged stock. We have a large stock of both of these varieties, and all our cuttings are heel cuttings, taken from flowering stems. On account of the quantity that we are growing, we are not obliged to over-propagate, and our stock is in the most perfect and healthy condition.

Strong rooted cuttings from sand, \$6 per 100, \$50 per 1000. Extra strong transplanted cuttings from soil, \$7.50 per 100, \$60 per 1000. Strong established pot-grown plants \$9 per 100, \$75 per 1000.

F. R. PIERSON CO.

Tarrytown - on - Hudson, . . . NEW YORK

CARNATIONS NOW READY

Afterglow, the finest pink, and **Britannia**, the English scarlet, \$12.00 per 100.
Aristocrat, **Winsor**, **Imperial**, **Beacon** and **Pink Imperial**, all at \$6 per 100, \$50 per 1000.
White Perfection, **Rob't Craig**, **Victory**, **Lady Bountiful**, **Mrs. M. A. Patten** and **Enchantress**, \$3 per 100, \$25 per 1000.
Queen, **Variegated Lawson**, **Fair Maid**, **Peary** and **Mrs. Lawson**, \$2.50 per 100, \$20.00 per 1000.

Booking orders for **GRAFTED ROSE STOCK** of all standard varieties.

CHARLES H. TOTTY

Send for complete list. MADISON, N. J.

Winsor Carnations.

From 6000 plants we have plenty of exceptionally fine stock, and 50,000 ready for shipment now. From 2 1/4 inch pots, \$7.00 per 100, \$60.00 per 1000. Rooted Cuttings, \$6.00 per 100, \$50.00 per 1000

A. N. PIERSON, - - Cromwell, Conn.

JOHN E. HAINES Bethlehem, Pa.

is the place to order rooted-cuttings of the following varieties for 1908.

John E. Haines, red	} Per 100 Per 1000
Imperial variegated	
Pink Imperial, Pink	
Enchantress, Light Pink	
Place your orders early for Jan. delivery.	

SPECIAL ATTENTION PRIVATE GARDENERS. CARNATION CUTTINGS AND PLANTS

	Per 100	Per 1000	2 1/4" pots Per 100
Andrew Carnegie , scarlet Harlowarden the best scarlet for you to grow,	\$12.00	\$100.00	\$15.00
Aristocrat , beautiful cerise,	6.00	50.00	8.00
Welcome silvery pink, very good, long stems,	6.00	50.00	8.00
Winsor , silvery pink, good producer,	6.00	50.00	8.00
Beacon , orange scarlet,	6.00	50.00	8.00
Red Chief , scarlet, produces 2-1 of any other scarlet,	6.00	50.00	8.00
White Enchantress , large stock of the true pure white,	6.00	50.00	8.00
Rose Pink Enchantress , true stock,	3.00	25.00	5.00
White Perfection ,	3.00	25.00	5.00
Daybreak Lawson or Melody ,	3.00	25.00	5.00
Victory good scarlet,	3.00	25.00	5.00
Enchantress , large stock,	2.50	20.00	5.00

Special Prices on Large Quantities. Send us your Order
CHICAGO CARNATION CO. (A. T. PYFER, MGR.) Joliet, Ill.

CARNATIONS WHITE ENCHANTRESS R. C. CARNATIONS ROOTED CUTTINGS

This stock originated with and grown by me is the very best.
 \$6.00 per 100, \$50.00 per 1000.

	Per 100	Per 1000
Enchantress , light pink,.....	\$2.50	\$20.00
Lawson ,.....	2.00	15.00
Lord , light pink,.....	2.00	15.00
Queen , white,.....	2.00	15.00
The Belle , white,.....	2.50	20.00

250 at 1000 rate. Orders of 1000 or more will be shipped prepaid on receipt of check.

Get your R. C. early and have blooms when others have none.

FRANK H. KIMBERLY
 631 Townsend Avenue, NEW HAVEN, CONN

ANNOUNCEMENT

Our new seedling carnation, **FOREADOR**, will not be disseminated until January 1909.

For further particulars address,
The H. WEBER & SONS CO., Oakland, Md.

Winona, color, true clear pink, comes nearest to **Fiancee** but a different type flower. Growth on order of **Scott** but vastly improved in every respect. Early flowers in quantity and on long stems. Does not burst its calyx. Fine, shapely, active growth. In color and productiveness it is without an equal. Orders booked now and filled in strict rotation. \$12 per 100, \$100 per 1000.

White Perfection, pure white. We have a large stock. \$3 per 100, \$25 per 1000.

F. DORNER & SONS CO.
 LA FAYETTE, IND.

Carnation Cuttings

Both standard varieties and novelties. Stock guaranteed to be first-class. Address,

S. S. SKIDELSKY
 1741 North 18th Street, Philadelphia

SPECIAL POINTS ON CARNATION HYBRIDIZING.

many petals, as the result will be too many extremely double flowers with no calyx to speak of.

Constitution, next to color, is the most important factor of a commercial carnation, from a grower's point of view, and should be given the utmost consideration. The parents should be selected and bred to such varieties as are noted for their healthy and vigorous constitution. We believe in order to gain the best results, this crossing should be done during the months of March and April, when plants are making their most vigorous and rapid growth, insuring well developed and ripened seed.

We sometimes question whether the condition and class of food with which we supply the mother plant crossing, and up to the time of ripening the seeds, is not responsible to some extent for our failures or successes as the case may be.

Regarding any other points on hybridization, I might suggest a strong, well rooted love for the work, untiring patience and perseverance, with a studious observation of the results—and a fair sized bank account at your disposal, until your aim has been attained.

CLUB AND SOCIETY NOTES.

The Newport Horticultural Society will hold their usual strawberry and rose show in June.

George T. Powell delivered the lecture before the American Institute of New York on February 5; subject, The Apple, King of Fruits.

At the meeting of the Dutchess Co. Horticultural Society in Poughkeepsie on January 29, the culture of roses was the theme under discussion.

G. Blair, of Silver Springs, has offered a prize of \$25 for the best display of flowers at the annual fair to be held at Rockville, Md., in August.

Arrangements now under way promise to make the meeting of the Illinois State Florists' Association at Springfield on February 18 and 19 a notable event. Arion Hall will be used for the meetings and a banquet and dance at St. Nicholas Hotel will be given on the last evening. Albert T. Hey of Springfield is president.

The advisory board of the Connecticut State Fair has been appointed. Rufus W. Stimson, President of Connecticut Agricultural College, is president; A. F. Hawes, state forester, Prof. W. E. Britton, J. F. Huss, R. C. Patterson, E. B. Smead, J. Arthur Smith, W. F. Andross, Hon. Henry C. Dwight are among the members. A pure seed congress is to be given in March, and the chairman, E. Alexis Taylor, Forestville, Conn., would be glad to hear from the seedsmen and to receive catalogues.

CATALOGUES RECEIVED.

William D. Burt, Dalton, N. Y.—Condensed Price List of Seeds.

J. A. McDowell, City of Mexico, Mex.—Trade List of Cacti, Orchids, Bulbs, 1908.

E. E. Stewart, Rives Junction, Mich.—1908 Trade Price List of Gladioli and Hardy Plants.

Johnston Harvester Company, Batavia, N. Y.—Descriptive List of the Johnston Mowers.

S. S. Pennock-Meehan Co., Philadelphia, Pa.—Folder of the new forcing rose Mrs. Jardine.

J. M. Thorburn & Co., New York.—Special Price List for Market Gardeners and Florists. A business document.

G. Edward Schultz, Washington, D. C.—Seed Annual for 1908. A select list. "Money Maker" Cantaloupe is a leader.

L. E. Williams, Nottingham, N. H.—Price List of Native Trees, Shrubs and Plants. A very complete list of collected material.

J. L. Moore, Northboro, Mass.—Catalogue and Price List of the Northboro Dahlia and Gladioli Gardens for 1908. An excellent collection.

L. L. Olds Seed Co., Clinton, Wis.—Catalogue 1908. Oderbrucker "The Great New Barley" and a set of new Sweet Peas in colors form the cover illustrations.

Henry Nungesser & Co., New York.—Wholesale Price List of Grass and Clover Seeds. This list is a standard and indispensable to the dealer in these specialties.

Leonard Seed Co., Chicago.—1908 Catalogue. A cluster of eschscholtzias in beautiful colors adorns the title page. Contents A 1. Also Market Gardeners' Catalogue.

Schlegel & Fottler Co., Boston, Mass.—Seeds, Plants and Bulbs for 1908. Cover handsomely illustrated in grey and white. Illustrations and arrangement excellent throughout.

Barteldes Seed Co., Lawrence, Kansas.—Western Seeds for Western Planters, 1908. A handsome catalogue with covers illustrated in colors and a fine agricultural and horticultural list.

Griffith & Turner Co., Baltimore, Md.—Catalogue of Farm and Garden Supplies. A showy cover in brown and gold and a specially complete list of implements are the characteristics of this catalogue.

H. E. Fiske Seed Co., Boston, Mass.—Seeds, Bulbs, Plants and Poultry Supplies. A unique catalogue, album form, with special cover illustrations of cosmos, asters and hollyhocks. A good novelty list is included.

W. W. Barnard Company, Chicago,



GLADIOLI

I can satisfactorily supply your wants for Gladioli for forcing or outdoor planting. Mixtures, color sections or named varieties of exceptional beauty.

Write for Prices

ARTHUR COWEE

Gladiolus Specialist

Meadowvale Farm, BERLIN, N. Y.

HYACINTHS, TULIPS, NARCISSI AND OTHER BULBS ROMAN HYACINTHS and the true PAPER WHITE GRANDIFLORA

Ask for our Wholesale Trade List at Hillegom

K. VELTHUYS, Hillegom, Hol and
Rep. by FELIX BOSCH, 260 Clarendon S., B. ston

III.—Annual Catalogue of Seeds, Bulbs, Plants for 1908. Handsome cream cover with illustrations of tomatoes and Dahlia Mrs. Roosevelt. Farm Seeds have special prominence.

W. Atlee Burpee & Co., Philadelphia, Pa.—1908 Wholesale Prices for Market Gardeners and Florists. Also Wholesale Catalogue for Seedsmen and Dealers only who buy to sell again. Both fully up to the Burpee standard.

C. C. Morse & Co., San Francisco, Cal.—Annual Catalogue of Seeds, Plants, Trees. A view of the firm's nurseries at Livermore with vignettes of roses in colors and a field of Florence Morse Spencer sweet pea make a very attractive cover. This sweet pea is Morse's special novelty for 1908, and it is a beauty which every sweet pea grower should have.

PUBLICATIONS RECEIVED.

Bulletin 209 of the New Jersey Agricultural Experiment Station, is an interesting description of novelties in vegetable fruits for general trial in 1908, by Prof. Byron D. Halstead. Sweet corn, tomatoes, egg plants, snap beans and summer squash seeds, the product of many registered crosses, are now offered for distribution and they will be sent to those who make application in writing in the order in which requests are received. The station is located at New Brunswick, N. J.

CELSIA ARCTURUS.

The showy plant which is the subject of our frontispiece this week was exhibited at Horticultural Hall, Boston, two weeks ago, and mention was made in our notes at that time of its availability for the commercial florists' show window. The flowers are bright yellow and the spikes last a long time before fully bloomed to the tips. It may be grown stocky by being kept close up to the glass. Otherwise it is inclined to grow too tall. Six or eight spikes of flowers at a time are not uncommon.

INCORPORATED.

King Construction Co., No. Tona-wanda, N. Y.; R. O. King, C. O. C. Hepworth, R. O. Spellman; capital, \$100,000.

The Summit Garden Co., Toledo, O.; Rupert Holland, W. H. Mosteller, W. H. Coalwell, P. S. Heabler, J. F. Le-Bold; capital, \$10,000.

Look through the Buyers' Directory and Ready Reference Guide. You will find some good offers there also.

LINCOLN PANSY SEED

Blended with extra fine strains of foreign and home grown seed, giving grand rainbow colorings.

Half Trade Packet, 50 cents
Trade Packets, \$1.00

W. ELLIOTT & SONS
201 Fulton St. New York

WIBOLTT'S SNOWBALL CAULIFLOWER-SEED

No. 34 is the earliest of all Snowballs, the most compact, the surest header, is giving the largest and snow-whitest heads, and is the best keeper in dry-weather. Demand it through your seed-firm or direct from
R. WIBOLTT, NAKSKOV, DENMARK

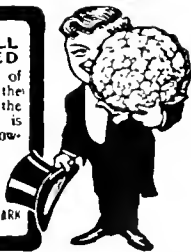

Cyclamen

Superb English Strain
Second to none in size of flowers
Giant Crimson.
" Pink.
" White.
" White with Claret base.
" Mauve.
" Salmon Queen.
" New Fringed.

100 seeds \$1; 1000 seeds \$9.

H. E. FISKE SEED CO.

12 and 13 Faneuil Hall Square, - BOSTON MASS.

**CAULIFLOWER'S
CABBAGE SEED**

HJALMAR HARTMANN & CO.,
12 Stormgade,
COPENHAGEN, DENMARK.

ESTABLISHED 1802

**Thorburn's
Seeds**

Send for our Wholesale Catalogue of Seeds for Florists and Market Gardeners, ready in a few days.

Per doz. Per 100
GLADIOLUS PRIMULINUS \$8.00 \$60.00
PRIMULINUS HYBRIDS 3.00 20.00

J. M. THORBURN & CO.
33 Barclay St., through to 38 Park Place
NEW YORK
Everything of the Highest Grade

CANNAS
A Quarter of a
MILLION
in over
FIFTY VARIETIES
(True to name)
CATALOGUES FREE
ARTHUR T. BODDINGTON
Seedsman
342 W. H St., NEW YORK CITY

	Pkt.	Oz.
Ageratum Blue Perfection	\$0.15	\$0.50
Alyssum Little Gem	.10	.35
Candy Tuft Empress	.10	.20
Bellis Snowball	.25	.25
" Longfellow	.25	.25
Salvia Splendens	.25	1.35
" Bonlire	.25	2.50
Verbena Mammoth Mixed	.25	1.50

BRIDGEMAN'S SEED WAREHOUSE
RICKARDS BROS., Props.
37 East 19th St., NEW YORK CITY

BRASLAN SEED GROWERS CO.
GROWERS FOR THE
WHOLESALE TRADE ONLY
SAN JOSE, - - CALIFORNIA

Burpee's Seeds
PHILADELPHIA

Blue List of Wholesale Prices mailed only to those who plant for profit

BAMBOO CANES

They cost about 10 per cent. more than other kinds, and they are 10 times better.
STUMPP & WALTER CO., - 50 Barclay St., New York

RELIABLE SEEDS—SOW NOW

	Tr.	6 Tr.
Alyssum Carpet Queen, real dwarf for pots only, no equal....	Pkt. Pkts.	\$0.25 \$1.25
Begonia Gracilis Luminosa, new Eriordia, beautiful.....	0.50	2.50
Lobelia, new Trailing Hamburgia	0.50	2.50
Petunia, Double Fringed Giants... Single Fringed Giants...	1.00 0.75	5.00 4.00
Phlox, best for pots, Fireball, Roseball, Snowball, each color.....	0.25	1.25
Salvia Fireball, new, a fine potter	0.50	2.50
Stocks, German 10 weeks: Blood-red, Lavender, Pink, Purple, White, each color.....	0.50	2.50
Verbena Mammoth: Pink, Purple, Scarlet, Striped, White, each	0.25	1.25

My New Price List Ready for the Asking
O. V. ZANCEN
Seedsman. HOBOKEN, N. J.

Best Quality Fall Bulbs

It is to your advantage to place your order early. Send us a list of your wants and we will quote you rock-bottom prices. Copy of our Florists' Bulb Catalogue will be sent upon request. Catalogues now ready.

VICK'S SUPERB PANSY SEED

All the best varieties in separate colors
VICK'S SUPERB MIXTURE
the best strain from all the leading named sorts
1-8 oz. 75c. 1-4 oz. \$1.50 Ounce \$5.00
JAMES VICK'S SONS, Rochester, N. Y.

CYCLAMEN

Farquhar's Giant Strain

Unsurpassed for size of flowers.
Giant Crimson Giant Pink
Giant White Finest Mixed
Giant Excelsior, White with Claret Base
100 seeds, \$1.25; 1000 seeds, \$10.00.

R. & J. FARQUHAR & CO.
6 & 7 So. Market St., Boston, Mass.

BRECK'S SEEDS

For Farmer, Market Gardener and Florist
New Crop High Grade
Catalogues mailed free on application
Joseph Breck & Sons Corp.
47-54 NO. MARKET ST., BOSTON, MASS.

JUST ARRIVED

LARGE SHIPMENT OF
High-Grade SCOTCH SOOT.
We have the Stott Double Nozzle
THOMAS J. GREY CO.
32 & 33 So. Market St., BOSTON

G. C. MORSE & CO.

Address all communications to our permanent address
48 to 56 Jackson St., San Francisco, Cal.
The Largest Seed Growers in the United States

FORMOSA LILIUM LONGIFLORUM

Ends the Growers' trouble
Absolutely free from Disease

WESTERN NEW YORK HORTICULTURAL SOCIETY.

Horticulturists from many states attended the 53rd annual meeting of the Western New York Horticultural Society, which convened in Rochester January 22 and 23. It was the largest and most successful series of sessions ever held by the society. The fruit exhibit was a grand display. Over a thousand plates of apples, pears and grapes were arranged on long tables, and the aisles were crowded all the time with interested growers. The larger part of the exhibit was from the State Experiment Station at Geneva, also a good-sized display from the Ellwanger & Barry nurseries, a number of plates of apples from the A. J. Smith farm, Gasport, and a table of apples of enormous size from Spokane, Wash., the exhibit of the Washington Real Estate Association.

The report of Secretary-Treasurer John Hall, as to the financial condition of the society, was gratifying. F. E. Rupert, chairman of the State Fair Fruit Exhibit committee, reported that the society won the first prize at the State Fair, though it was by a scant margin and he urged that the members pay more attention next fall and contribute more fruit.

William C. Barry, president of the society since 1890, delivered his address. He referred to the age of the society and what it had accomplished for fruit growers. Dr. W. H. Jordan, director of the New York Agricultural Experiment Station, Geneva, spoke of "Twenty-five Years of Experiment Station Work." "Tillage vs. the Sod-Mulch," by Prof. C. P. Hedrick, was an address of interest. There has long been contention between the factions that support the two methods of fruit culture. The conclusions of the speaker were strongly in support of tilling the soil and against the sod mulch method, and he cited many facts in support of his position.

Mr. C. Burritt of Cornell University gave a paper on "Co-operation in the Packing and Marketing of Orchard Fruits." Prof. P. J. Parrott, entomologist at the State Experiment Station, spoke on "Some Observations on Fruit Insects." He gave a comprehensive outline of the various pests that infested apple trees, also of the use of spraying machines. Great interest was manifested in his talk on the San Jose scale.

Prof. F. C. Stewart, of the Experiment Station, chairman of the committee on botany and plant diseases, reported in part as follows: "So far as fruit diseases in New York are concerned the past year was in no way especially noteworthy. There was no remarkable outbreak of any new disease and no alarming epidemic of the old ones. Neither are we aware of any strikingly important discoveries on the cause or control of the fruit diseases. In short, 1907 was just an ordinary

year in which fruit growers have had their usual troubles with fungus diseases, while plant pathologists, the world over, have been gradually extending our knowledge of things.

"Grape growers may be interested to know that the Ohio station is making an investigation of the dying of its bearing grape vines. It appears to be the same as a disease occurring in the Chautauque grape belt of this state, where it is known as the 'side arm' disease." Other station investigations of interest to grape growers are the spraying experiments and black rot studies which the Cornell station has under way.

"Another subject to which we have given some attention at the station recently is a carnation disease called bud-rot. For many years florists have had more or less trouble with carnation buds failing to open properly. The only treatment which can be recommended is the gathering and burning of diseased buds."

There were many more speakers, and many subjects considered during the sessions. George T. Powell, of Ghent, conducted the members' hour, in which anyone in the audience was permitted to ask questions, or speak on any subject which interested him. Six minutes was allowed each speaker, and the time was filled with many pertinent remarks from fruit growers.

The committee on resolutions summed up the work accomplished by the meeting and referred to the time given to the discussion of soil improvement as being in the best interest of the membership and closely related to the social problem affecting the migration from rural sections to villages and cities. The resolutions recommended that the members work for a liberal appropriation by the Legislature to expand the work.

The officers for the ensuing year are as follows: President, William C. Barry, Rochester; vice-presidents, S. P. Willard, Geneva; J. S. Woodward, Lockport; S. W. Waddams, Clarkson; Albert Wood, Carlton; secretary-treasurer, John Hall, Rochester.

PERSONAL.

Edw. Roehrs of Rutherford, N. J., is in Boston this week.

J. K. M. L. Farguhar of Boston visited New York this week.

Visitors in Chicago: Wm. Hagemann, New York; Emil Pielke, Geneva, Ill.

B. D. Kapteyn, representing Gt. van Waveren & Kruyff, Sassenheim, Holland, is in New York this week.

L. D. Robinson, Sr., Springfield, Mass., has had an attack of the grippe which has developed into erysipelas in the head.

Mark Aitken, florist, of Springfield, Mass., who has been ill with pneumonia for two weeks, is reported to be improving.

HORTICULTURE'S REPRESENTATIVES.

The following named gentlemen represent this paper in their various local districts, and are authorized to accept subscriptions, advertisements and news items:

BUFFALO, N. Y.—E. C. Brucker, 385-87 Ellcott St.

CINCINNATI, OHIO—Frank W. Ball, 31 East 3d St.

DETROIT, MICH.—Frank Danzer, 1487 15th St.

INDIANAPOLIS, IND.—George B. Wiegand, 1610 N. Illinois St.

MONTREAL, P. Q.—Gabriel Vrengde, 27 Ontario Ave.

NEWPORT, R. I.—David McIntosh, Ledge Road.

MINNEAPOLIS, MINN.—C. N. Ruedlinger, 2924 So. Aldrich Ave.

PHILADELPHIA, PA.—George C. Watson, Dobson Bldg., 9th and Market Sts.

PITTSBURG, PA.—Jasme Hutchinsan, corner Dunwoyle and S. Negley Ave.

TOLEDO, OHIO—J. L. Schiller, 929 Prouty Ave.

SEED

Cocos Weddelliana

SPECIALLY SPLENDID SEED

\$4 per 1000
\$36 per 10,000

Carriage free.
Cash from unknown correspondents.

Sander & Sons, BRUCES, BELGIUM

Just Received in Splendid Condition

15,000 AZALEAS

in all sizes and varieties

25c. up to \$2.00 each
Also Kentias, Rubbers, Araucarias, Pandanus, Boxwood, Euonymus, Crotons, Areca and Eurya latifolia.

Extra good value in large
Specimen and Decorative Palms
A. LEUTHY & CO.

Perkins Street Nurseries, Roslindale, Mass.

NEP. WHITMANI

2½ in., \$5.00 per 100

NEP. WHITMANI

3½ in., \$25.00 per 100

BOSTON FERNS

2¼ in., \$3.00 per 100

H. H. BARROWS & SON Whitman, Mass.

FERNS

Boston, 4 inch 12c, 5 inch 25c.

Pteronit, 3 inch 8c.

Elegantissima, 2½ inch 6c, 3 inch 10c,
4 inch, 15c.

BAUR FLORAL CO., Erie, Pa.

DREER'S SUPERB DOUBLE PETUNIAS



For half a century we have been making a specialty of DOUBLE PETUNIAS and our strain is accepted as second to none, either here or in Europe. We annually plant many thousand seedlings from which only the finest double fringed forms are selected for propagating purposes, thus improving the strain every season. We offer fifteen distinct varieties.

3-inch pots, 75c per doz.; \$6.00 per 100; the set of 15 for \$1.00.
2 1/4-inch pots, 60c per doz.; 4.00 per 100; the set of 15 for .75.

SEED OF OUR SUPERB STRAIN OF FRINGED PETUNIAS. Double, 75c per 500 seeds; \$1.50 per 1000 seeds. Single, 50c per trade packet; \$1.00 per 1 lb oz; \$1.50 per 1/2 oz.

Our Quarterly Wholesale List offers a full line of seasonable Plants, Seeds and Bulbs.

HENRY A. DREER, PHILADELPHIA, PA.

PELARGONIUMS

We have a fine lot of strong plants in 3 inch pots of Purity, Countess of Crew, Duke of Cornwall, Galatea, Gloriosa, Lady Carrington, Tommy Dodd and others at \$1.50 per doz., \$6.00 per 100.

GERANIUMS Our new illustrated catalogue mailed to the trade. We have a fine lot of standard varieties and novelties from \$1.00 per 100 up, good stock from 3 inch pots. We will send 1000, 50 each of 20 good sorts for \$18.50; 500 for \$9.25. Cash with order. Not less than 500 sent at this price. See last week's issue for Miscellaneous stock, including Dahlia Roots.

R. VINCENT Jr. & SONS COMPANY
White Marsh, Md.

NEW—A MONEY MAKER—NEW CARTER'S DOUBLE BLUE LOBELIA

\$2.50 per doz., \$18.00 per 100

CASH WITH ORDER PLEASE. J. FULLER, 31 Orchard St., LEOMINSTER, MASS.

GODFREY ASGHMANN

Importer and Wholesale Grower and Shipper

of Araucaria Excelsa, Compacta, Robusta and Glauca; Kentia Forsteriana and Belmoreana Azalea, Indica, etc. Cultivator of Boston, Scottii, Barrowsii, Elegantisima and Whitmanii Ferns. Ferns for dishes, Cocos, etc. Write for prices.

1012 Ontario St., Philadelphia

AZALEAS FOR FALL DELIVERY

The best that are grown, also

Palms for Spring or Fall delivery furnished by AUGUST HAERENS, Somergem, Belgium. Orders booked now. Address the American representatives.

AUGUST ROLKER & SONS, New York
31 Barclay Street, or P. O. Box 752

NEPHROLEPIS SCOTTII

in the following sizes, extra good value

25c., 50c., 75c., and \$1

Grand Specimen Plants at \$3, \$4, \$5, \$6.

J HN SCOTT

R Highland Road and E. 45th St.

Tel. 2290 Bedford BROOKLYN, N. Y.

LILIUM AURATUM

9-11 \$75 per 1000

ROSEUM and RUBRUM

9-11 \$65 per 1000

MULTIFLORUM

7-9 \$45 per 1000

D. RUSCONI, 128 West 6th St., CINCINNATI, OHIO

Keep Your Eye Open

FOR BARGAINS IN GOOD STOCK

See the BUYERS' DIRECTORY and READY REFERENCE GUIDE. Pages 184, 185, 186, 187, 188.

Everything offered in this paper is listed there.

Look it over before buying and, in ordering please refer to advertisement in

HORTICULTURE

ORCHIDS

Largest Importers, Exporters, Growers and Hybridists in the World

Sander, St. Albans, England
and 235 Broadway, Room 1
NEW YORK CITY

... ORCHIDS ...

Just to hand, C. Trianae, C. labiata, C. Mossiae, C. Intermedia, C. Schroderae, C. Speciosissima, C. Cirina, C. Gaskelliana, Laelia anceps, L. Albida, L. majalis, L. Autumnalis, Epidendrum Vittelinum majus, E. Cooperianum, Oncidium Crispum, O. Varicosum, O. Cavendishianum, O. Luridum, Odonto. Citrosomum. To arrive in a short time, C. Dowiana, C. Aurea, C. Warnerii, Miltonia Vexillaria.

GARRILLO & BALDWIN SEGAUCUS, N. J.

ORCHIDS for Spring Delivery

NEW IMPORTATIONS

Cattleyas, Laelias, Oncidiums, etc.

WRITE FOR PRICES

Now is the time to Pot Orchids. Pest Quotations of Peat, Moss and Baskets on hand.

JOSEPH A. MANDA, 191 Valley Road, WEST ORANGE N. J.

Write at once for our quotations on all

ORCHID IMPORTATIONS

FOR 1908 DELIVERY

JULIUS ROEHRS CO.,

The Orchid Nurseries, Rutherford, N. J.

ORCHIDS

We are at present booking orders for freshly imported Orchids for delivery 1908, of all leading kinds at reduced prices. We have just received the following:—Oncidium Sarcodes, O Forbesii, O Tigrinum and Sophronites, Grandiflora and Coccinea.

LAGER & HURRELL, Summit, N. J.

ORCHIDS

The largest importation of Orchids ever received in this country WILL ARRIVE next spring from Brazil, Colombia and Venezuela. If you intend putting in stock wait for these to arrive and we will quote the Lowest Prices in America.

ORDONEZ BROS., - Madison, N. J.

JAPANESE
THE YOKOHAMA NURSERY CO. NEW YORK.
31 BARCLAY STR.
LILIES
PLANTS
BAMBOO STAKES

Prices Quoted in these Columns are for Dealers Only. When Writing to Advertisers Please Mention HORTICULTURE.

PHILADELPHIA NOTES.

Mrs. William I. Baker, who has recently passed through a serious operation at the Hahneman Hospital, was reported on the 3rd inst. as progressing favorably, and her family are in good hopes of having her home again in a week or two.

Liddon Pennock of Pennock Bros., has been laid up for over a week threatened with typhoid. The case is a grave one, apparently, but the physicians have not yet been able to diagnose same.

Clarence J. Watson, head of the Niessen force's, has been down for over a week with the grippe.

Edwin J. Fancourt of the Pennock-Meehan Co. has also been a victim. We hear of others but fear this report may look more like a hospital than a horticultural symposium if we tell all we know, so we leave the rest of them with our best wishes for speedy recovery.

William P. Craig is home from the convention feeling proud of himself and receiving congratulations on being the only one thoughtful and courageous enough to supply the President's omission of a carnation in his button-hole on McKinley day. The President thanked Mr. Craig very cordially.

James Krewson of Cheltenham is making an active canvas for county commissioner of Montgomery county, this state, and seems in a fair way to land the prize. He has the cordial support of Senator Roberts and the best element in his district.

Wedding bells will ring shortly for Miss Elizabeth Olmes of Altoona and A. E. Wohlert of Merion. Mr. Wohlert is a member of the Philadelphia Florists' Club and one of the most popular and successful landscape gardeners and contractors in this vicinity.

Edwin Lonsdale claims to have been the first to grow carnation plants for stock under glass during the summer months. He states that it was largely accidental and took place during the Grace Battles' period, some seventeen years ago.

NEWS NOTES.

Niles Nelson, Jr., Portland, Me., has been admitted into partnership with his father in the florist business.

The Greek-American Retail Florists' and Growers' Association, New York, has leased rooms at 118 Lexington Ave.

Silas D. Weymouth is to have charge of the eastern agency of the Phoenix Nursery Co. to be established at Waterville, Me.

W. F. Gale has been reappointed City Forester of Springfield, Mass., and the appointment has been confirmed by the Board of Aldermen.

The florists of Dighton, Mass., have held several sessions recently to fix a uniform price on potted and box plants for the coming season.

George M. Roak, florist, of Auburn, made a fine exhibit of potted plants and flowers at the Food Fair at Lewiston, Me., held last week.

A petition in bankruptcy has been

BOXWOOD

Finest quality, \$17.50 per Cwt.

GALAX Green, \$1.00 per 1000; \$7.50 per 10,000.
Bronze, \$1.00 per 1000; \$7.50 per 10,000.

Hardy Ferns, Best Grade. \$1.50 a 1000

LAUREL, MOSS, PRINCESS PINE, FESTOONING.

N. F. McCARTHY & CO. Telephone 5973-5974 Main **84 HAWLEY ST., BOSTON**
Largest Dealers in Florists' Supplies in New England

EXTRA FINE BOXWOOD \$17.50 per CWT.

FANCY FERNS, A No. 1 Quality, \$1.50 per 1000
GREEN CALAX \$1 per 1000, \$7.50 per 10,000
BRILLIANT BRONZE \$1 per 1000, \$8.50 per 10,000

Headquarters for HARDY FERNS, MOSS, LAUREL, PRINCESS PINE, FESTOONING, Etc. See Our Cut Flower Ad.

HENRY M. ROBINSON & CO., FLORISTS' SUPPLIES **15 Province St., and 9 Chapman Pl., BOSTON**

filed against L. I. Neff, florist, Pittsburg, Pa. The claims of the three petitioning creditors amount to \$4,100.

Construction work in the parks of Madison, Wis., will be active this year. Two marine dredges are now engaged in park projects, this being the fourth year of work by this means.

The Carolina Floral Co., Charleston, S. C., is remodelling its store and introducing many improvements which will make it one of the handsomest places of the kind in that section.

J. A. Newsham, New Orleans, La., has disposed of a part of his stock and houses to Knollock & Buechner, who will carry on the business. Mr. Newsham will give his entire time to the Magnolia Nurseries.

In our account of the exhibition of the Massachusetts Horticultural Society at Boston on January 25 we failed to mention the very large and handsome Lorraine begonias staged by William Downs, of Chestnut Hill, Mass.

Curbside vendors of violets have been ordered to keep off Chestnut street, Philadelphia. Quite a number of them, mostly Greeks, have been arrested and fined \$5.00 each for persisting in disobedience of this edict.

On the ground that a trespass had been committed a jury in the Supreme Court Circuit, late yesterday afternoon awarded damages amounting to \$1,700 to William A. Manda in a suit against the city of Orange and Ludwig Batt. The jury deliberated five hours, and, it is said, was a unit in the conclusion that the allegations had been proved, but took twelve ballots to determine the financial award.—Newark, N. J., News, Feb. 4.

E. A. BEAVEN
Southern Wild Smilax,
Log Mosses,
Natural and Perpetuated— at Wholesale,
EVERGREEN, ALABAMA.

BOSTON FLORIST LETTER CO.
Manufacturers of **FLORISTS' LETTERS**

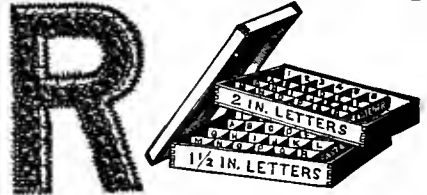

This wooden box nicely stained and varnished, 18x30x12, made in two sections, one for each size letter, given away with first order of 500 letters

Block Letters, 1 1/2 or 2 inch size per 100, \$2.
Script Letters, 3. Fastener with each letter or word. Used by leading florists everywhere and for sale by all wholesale florists and supply dealers

N. F. McCARTHY, Manager
66 Pearl Street, BOSTON, MASS.

BOXES BOXES BOXES
LIGHT WOOD CUT FLOWER BOXES
Sizes in Stock per 100

3 x 4 x 20	\$4.00
3 x 5 x 24	4.50
3 x 7 x 21	4.50
6 x 6 x 24	6.80
4 x 12 x 24	9.00
6 x 12 x 24	10.50
6 x 12 x 30	12.50
5 x 12 x 36	14.00
6 x 12 x 36	15.00
6 x 15 x 42	20.00
6 x 15 x 48	23.00

Write for samples and prices in car load lots.
GETMORE BOX FACTORY, Incorporated,
BELLEVILLE, ALA.

The "Japana" Cut Flower Holder



A handy article for florists. Sells to the trade on sight. Made of glass in three sizes. The "Anglais" Table Decoration, something entirely new, long needed. The florist and housewife will appreciate this article, as it simplifies the art of table decorating

Ask for catalog.
M. V. CARNSEY, Dept. F,
130 Waiola Ave., La Grange, Ill.

KORAL SCRIPT LETTERS AND EMBLEMS
ONCE USED ALWAYS USED
Forsale by at first class supply houses. Made by
KORAL MFG. CO.
26 Hawley St., Boston

JOHN BREITMEYER'S SONS

Cor. Miami and Gratiot Aves.
DETROIT, MICH.

Artistic Designs . . .
High Grade Cut Blooms

We cover all Michigan points and good sections of Ohio, Indiana and Canada

P. J. and J. E. HAUSWIRTH

232 Michigan Ave.
CHICAGO

AUDITORIUM ANNEX Tel. Harrison 585

SAMUEL MURRAY Florist

Coates House Conservatory
1017 BROADWAY, KANSAS CITY, MO
Both 'Phones 2670 Main

FRED C. WEBER FLORIST

4326-28 ST. LOUIS, MO.
OLIVE STREET
Established 1873
Long Distance Phone Bell Lindell 676



WASHINGTON,
D. C.

GUDE'S

Geo. H. Cooke FLORIST

Connecticut Avenue and L Street
WASHINGTON, D. C.

The Park Floral Co.

J. A. VALENTINE
Pres.

DENVER, COLORADO

WILLIAM L. ROCK FLOWER CO.

KANSAS CITY, MO.
will carefully execute orders for Kansas City and any town in Missouri or Kansas.

ALBANY, N. Y.

EYRES

Flowers or Design Work

DELIVERED IN ALBANY AND VICINITY ON TELEGRAPHIC ORDER.

11 NORTH PEARL ST., ALBANY, N.Y.

BUSINESS CHANGES.

Sawyer & McDaniels succeed M. I. O'Brien at Sharon, Pa.

The Dodds Floral Co., 55th St., Chicago, have discontinued business.

N. Cocaliaries withdraws from the firm of N. Lecakes & Co., New York.

Miss Mary Hicks will continue the business of the late Mrs. C. W. Pike at Racine, Wis.

Fairview Nursery Co., Berkeley, Cal., is the title adopted by L. M. Barrett, S. E. and T. R. Barrett.

NEW RETAIL FLOWER STORES.

O. B. Palmer, Cherokee, Ia.

John Barrow, Adams St., Toledo, O.
Watkins & Nicholson, Hammon, N. J.

The Ansonia Floral Co., Main St., Ansonia, Conn.

On Friday night, January 31, the Greek-American Retail Florists' and Growers' Association held its annual ball at the Palm Garden, New York. There was a large attendance not only of the florists of the Greek persuasion but of florists and wholesalers generally. When the Greeks undertake anything of this sort expense is not considered and this affair was carried through on a scale of characteristic liberality.

LEADING RETAIL FLORISTS—
Index by Towns will be found in Buyers' Directory.



Send flower orders for delivery in

BOSTON

and all

NEW ENGLAND POINTS
THOS. F. CALVIN
124 Tremont St., Boston

TRANSFER

Your orders for flower or plant delivery in Eastern New England to

JULIUS A. ZINN,
2 Beacon St., Boston.

Fine Design Work a Specialty.

YALE

Orders for flower deliveries to Yale College and all other Connecticut

points carefully filled and delivered by

J. N. CHAMPION & COMPANY
1026 CHAPEL STREET NEW HAVEN, CONN.

ATLANTA FLORAL CO.

41 Peachtree Street, ATLANTA GEORGIA.

Florists Out of Town

Taking orders for delivery in New York or Vicinity can have them filled in best manner and specially delivered by

Thomas Young, Jr.

500 Fifth Ave., New York City
Telephone 847 Bryant.

ALEX. McCONNELL

571 FIFTH AVENUE
NEW YORK CITY

Telegraphic orders forwarded to any part of the United States, Canada, and all principal cities of Europe. Orders transferred or intrusted by the trade to our selection for delivery on steamships or elsewhere receive special attention.

Telephone Calls, 487 and 488 38th St.
Cable Address, ALEXCONNELL

WILLIAM H. DONOHUE

FLORAL DECORATOR

17 East 28th St., New York

Special Attention to Theatre and Steamer Orders, and reliable deliveries guaranteed.

DAVID CLARKE'S SONS

Deliver orders from any part of the country to New York City

Or OUT-GOING STEAMERS

Write or telegraph

2139-2141 Broadway, New York
Telephone 1552-1553 Columbus

PROMPT DELIVERY IN BOSTON

AND ALL NEW ENGLAND POINTS

HOUGHTON & CLARK

396 Beylston St., Boston, Mass.

Flower Deliveries

In Brooklyn and other Long Island Points New York City, New Jersey etc. At Theatres, Hotels, Steamers or Residence.

WILSON

Fulton St. and Greene Ave., Brooklyn, N.Y.

YOUNG & NUGENT

42 West 28 St., NEW YORK

"FLOWERS BY TELEGRAPH"

William J. Smyth FLORIST

Cor. Michigan Ave. and 31st St., CHICAGO

We ship to all points in Illinois and Iowa.

Phones: Douglas 744, Douglas 523, Douglas 740

JACOB SCHULZ, 644 Fourth Ave., LOUISVILLE, KY.

Cut Flowers of BEST QUALITY in season delivered promptly to any address.

Write, Telegraph or Telephone.

Cumberland and Home Phones 223 and 984

A Fine Assortment of
==AZALEAS==
 Extra fine lot of FIREFLY in bloom from
NOW UNTIL EASTER
 WRITE FOR PRICES
MAJOR BONNAFFON
 The best all 'round Yellow Chrysanthemum. Strong stools,
 \$5.00 per 100
W. W. EDGAR CO., Waverley, Mass.

Cattleya Trianae
 \$6 per doz., \$40 per 100
CHOICE VALLEY WHITE VIOLETS
 \$3.00 and \$4.00 per 100 \$1.50 per 100
S. S. PENNOCK-MEEHAN CO.
 1608-1620 Ludlow St. PHILADELPHIA
 "The" Wholesale Florists of Philadelphia

EVERYTHING SEASONABLE IN
CUT FLOWERS
EDWARD REID, Wholesale Florist
 1526 Ranstead St., PHILADELPHIA
 STORE CLOSES 8 P. M.

CHAS. W. MCKELLAR
 51 WABASH AVE., CHICAGO
 Western Headquarters for Choice Orchids
 Valley, Roses and all Cut Flowers

PETER REINBERG WHOLESALE
CUT FLOWERS
 51 Wabash Av., Chicago, Ill.
 In writing advertisers, mention Horticulture

CUT FLOWER BOXES
EDWARDS FOLDING BOX CO
 MANUFACTURERS
 PHILADELPHIA, PA.

AMERICAN BEAUTY and all other ROSES
LILY OF THE VALLEY, CARNATIONS
WELCH BROS., 226 Devonshire St., Boston, Mass.

TRUMPET MAJORS
 Extra Quality Any Quantity
W. E. MCKISSICK WHOLESALE FLORIST
 PHILADELPHIA
 1619-1621 RANSTEAD ST.

WHOLESALE FLOWER MARKETS—TRADE PRICES—Per 100 TO DEALERS ONLY

	CHICAGO Feb. 3	TWIN CITIES Feb. 4	PHILA. Feb. 4	BOSTON Feb. 5
ROSES				
Am. Beauty, Fancy and Special...	30.00 to 40.00	40.00 to 50.00	50.00 to 60.00	50.00 to 75.00
" " Extra	25.00 to 30.00	35.00 to 40.00	30.00 to 50.00	20.00 to 30.00
" " No. 1	15.00 to 25.00	20.00 to 30.00	25.00 to 30.00	10.00 to 15.00
" " Lower grades	5.00 to 10.00	10.00 to 15.00	6.00 to 10.00	6.00 to 8.00
Bride, Maid, Fancy & Special...	10.00 to 12.00	10.00 to 12.00	12.00 to 13.00	13.00 to 12.00
" " Extra and No. 1	8.00 to 10.00	8.00 to 10.00	10.00 to 12.00	6.00 to 8.00
" " Lower grades	4.00 to 6.00	4.00 to 6.00	4.00 to 8.00	2.00 to 4.00
Killarney, Richmond, Fan & Sp...	3.00 to 4.00	3.00 to 4.00	12.00 to 12.00	20.00 to 25.00
" " Lower grades	4.00 to 6.00	4.00 to 6.00	4.00 to 12.00	4.00 to 6.00
Chatouay, Wellesley, Fan & Sp...	12.00 to 15.00	5.00 to 12.00	12.00 to 15.00	15.00 to 15.00
" " Lower grades	6.00 to 10.00	4.00 to 6.00	4.00 to 10.00	6.00 to 8.00
Golden Gate, Ivory	10.00 to 10.00	8.00 to 12.00	4.00 to 10.00	10.00 to 8.00
CARNATIONS				
Fancy and Novelties	2.00 to 4.00	4.00 to 5.00	3.00 to 5.00	5.00 to 6.00
Ordinary	1.50 to 2.00	3.00 to 4.00	1.00 to 3.00	3.00 to 1.50
MISCELLANEOUS				
Violets	.50 to 1.00	1.00 to 1.25	.25 to 1.00	.40 to .75
Cattleyas	50.00 to 60.00	50.00 to 60.00	50.00 to 60.00	40.00 to 50.00
Cyrtipediums	10.00 to 15.00	12.00 to 15.00	12.50 to 15.00	15.00 to 12.00
Lilies	12.00 to 15.00	15.00 to 18.00	12.50 to 15.00	15.00 to 12.00
Lily of the Valley	2.00 to 4.00	3.00 to 5.00	2.00 to 5.00	1.00 to 2.00
Freesias	2.00 to 4.00	2.00 to 4.00	2.00 to 4.00	4.00 to 1.00
Rom in He., Paper White Nar...	2.00 to 3.00	3.00 to 4.00	1.00 to 3.00	1.00 to 2.00
Daffodils	3.00 to 3.00	3.00 to 3.00	2.00 to 2.00	4.00 to 3.00
Tulips	2.00 to 3.00	3.00 to 3.00	2.00 to 3.00	3.00 to 3.00
Mignonette	4.00 to 4.00	3.00 to 6.00	2.00 to 6.00	6.00 to 6.00
Gardenias	40.00 to 5.00	5.00 to 5.00	25.00 to 50.00	25.00 to 40.00
Lilac per bunch	1.50 to 1.50	1.50 to 1.50	1.50 to 2.00	.50 to 1.75
Sweet Peas	.50 to 1.50	1.50 to 1.50	1.50 to 1.50	1.00 to 1.00
Achoatum	1.75 to 1.00	1.00 to 1.50	1.00 to 1.50	1.00 to 1.50
Whitmanii Fronds	1.00 to 1.00	1.00 to 1.00	1.00 to 1.00	1.00 to 1.50
Smilax	10.00 to 15.00	14.00 to 18.00	12.50 to 20.00	1.00 to 16.00
Asparagus Plumosus, strings	35.00 to 50.00	42.00 to 60.00	50.00 to 75.00	50.00 to 50.00
" " & Spreo. (100 bchs.)	35.00 to 35.00	4.00 to 60.00	50.00 to 50.00	50.00 to 50.00

DAILY CONSIGNMENTS
 From 40 to 60 Growers
 We can care for your cutflower wants to advantage.
E. F. WINTERSON CO.
 45-47-49 WABASH AVE., CHICAGO

J. J. HARTY & COMPANY
 WHOLESALE AND COMMISSION **FLORISTS**
 1312 G Street, N. W., Washington, D. C.

THE FLORISTS' SUPPLY HOUSE OF AMERICA
 Without a rival in knowledge of the requirements of the trade and the ability to supply them. Our New Illustrated Catalogue, recognized as a work of art unprecedented in its line for variety, novelty and completeness, tells the story fully, and if you have not yet sent for it, do so now.
 'TIS FREE TO EVERYBODY IN THE TRADE
H. BAYERSDORFER & CO., 1129 Arch St., Philadelphia, Pa.

FLOWER MARKET REPORTS

In his speech at Washington last week Mr. Skidelsky referred to the carnation as "the flower of the masses, grown everywhere, sold everywhere." The carnation is certainly doing its best to live up to this mark in Boston at the present time. It is doubtful if ever before the market was so overwhelmed with the divine flower. All colors, all varieties, all grades, but mainly of the best, have been railroaded in until they are stacked up in most unwieldy profusion in wholesalers' hands. It is hard to recall a year when the market has been so quiet. Roses are the redeeming feature and move fairly well, American Beauties, Brides and Bridesmaids taking the lead. Violets are slow. Bulb stock is a drag and brings only low figures.

Trade was not very active the past week, doubtless due to the severe cold weather, which has the florist at its mercy. Social functions are on the quiet list, while the most prominent balls have passed. Stock on most lines could be had at any moment save short grade of white and pink roses, which were in heavy demand. Select Killarney, Richmond and Gates could be obtained but prices ruled high. The crops of carnations are on with most every one; the light varieties sell the best, but there are a good many of ordinary grade to carry over. Sweet peas of excellent quality are coming in, also La Reine tulips, jonquils, daffodils, mignonette, lily of the valley, violets, Harrisii lilies, for all of which there is only a normal demand. The supply of carnations for McKinley day exceeded the demand. The outlook for a big day's business seemed bright; had it not been for the severe cold weather the sales would have doubled, though prices advanced but little.

The cold, stormy weather of the past week, the temperature below freezing and on Sunday five degrees below zero, with attendant cloudiness, has shortened the rose crop materially. Bulbous stock is coming in plentifully but there is not much demand for same. Carnations are holding at steady prices. Single and double violets are abundant and of good quality. Among the retailers there is a feeling that the past month might have been worse if it had not been for funeral work. Plants of Primula obconica are conspicuous in show windows and are in good demand.

Business is moving along too easy for the ambitious ones, but as the January figures show a greater profit than one year ago this again proves the old proverb, "A steady drop follows the stone." We all are naturally aching for a swifter turn and bookings

made for the near future seem to hold that in store for most of us.

Business is anything but reasonable. The rose supply is not at all large, but quite ample for all demands. American Beauties are light in supply and the best grade brings good figures. Cattleyas and gardenias on account of a decreasing cut, are selling at better figures. Carnations are plentiful—much too plentiful to realize anything approaching prices usually obtained in mid-winter; in fact, the record of the past ten years does not show such poor results as at the present time. Bulb stock of all kinds is extremely plentiful and cheap; the same applies to violets.

Normal conditions prevailed in this market the past week. Sweet peas, Roman hyacinths, and Paper White narcissi were in large supply and much in excess of what the market could absorb. Carnations, on the other hand, cleaned up nicely until Thursday. After that the demand was weak. American Beauty roses, compared with same date last year, are better and more plentiful. Richmonds are in demand and are not over-plentiful. Fancy Bridesmaids and Killarneys are selling well, but there is very little call for medium grades. In Brides, the lower grades sell best. Cattleyas have the call in the orchid market, with Trianae leading. Cyripediums are draggy. Trumpet daffodils, freesias and tulips move out in large quantities, but the prices are much in buyer's favor. Easter lilies are neglected—as is mignonette for the time being—but strange to say the call is in active demand, with quality and quantity both up to the mark. Violets and lily of the valley both slightly improved as compared with a week ago and moving out a little better.

The greenhouses of Walter Scarlett, Kennett Square, Pa., were destroyed by fire on Jan. 20; the contents of one house was all that was saved. Loss \$3,000.

J. KOPELMAN & CO.

Wholesale Dealers in

Cut Flowers and Florists' Supplies
EVERGREEN AND FERN LEAVES
OF ALL KINDS.

21 Washington St., PROVIDENCE, R. I.
Telephone Connection.

ROBERT J. DYSART,

Public Accountant and Auditor

Simple methods of correct accounting especially adapted for florists' use.

Books Balanced and Adjusted

Merchants Bank Building

28 STATE ST., BOSTON
Telephone, Main 38

The KERVAN CO. 113 W. 28th ST.
New York

WHOLESALE DEALERS

Fresh cut Palmetto & Cycas Palm Leaves, Galax, Leucothea, Ferns and Mosses. All Decorating Evergreen.

Bargains in Plants

If you want bargains in plants watch the ads appearing

Exclusively in Horticulture

The Philadelphia Plant Exchange is just what its name implies:—

BARGAINS to YOU!

We hunt for them, and our guarantee goes with every one! Personal inspection and guarantee.

This week's Bargain offers

Lot No.		EA. H
101	500 Kentia Forsteriana, 6 in.,	\$1.50
102	200 " " " 7 in.,	2.00

The above two lots (Nos. 101 and 102) are made up plants, clean and well furnished. A decided bargain at the price.

CARNATION CUTTINGS

Lot No.		100	1000
103	4000 Boston Market	\$2.00	\$18.00
104	3000 Enchantress	2.50	20.00
105	3000 Joist	2.00	17.00
106	3000 Marion	2.00	17.00

FERNS AND RUBBERS

Lot No.		100
107	1000 Mixed Ferns, 3 in., 1/2 vars.	\$7.00
108	400 Whitman, 4 in.	25.00
109	500 Todea, 3 1/2 in.	20.00
110	500 4 in. Rubbers, fine plants	25.00
111	500 Rubber Cuttings, (well rooted)	15.00

Send us your orders or inquiries for anything you want. The above is only a sample of the immense stocks of fine plants behind our organization.

Also if you have anything to sell let us know. If your stock is all right, after our personal inspection, and such as we know will please our customers, we will handle it for you and find a market, but it must be first class and a bargain. Our only charge is 10% on sale price.

Don't Grow Crops there's No Demand For

Write us first. We cannot handle anything unless it is first class in every way. That's the meaning of our guarantee to customers.

Address all orders to

Philadelphia Plant Exchange
839 Market Street
PHILADELPHIA

Keystone Phone 5248 D Main Bell Phone 5639 Walnut

JOHN YOUNG
WHOLESALE FLORIST
 Finest American Beauties and
 Carnations
 51 West 28 St. - NEW YORK

FORD BROTHERS
 48 West 28th Street, NEW YORK
FINE ROSES FANCY CARNATIONS
 A Full Line of All CUT FLOWERS
 Telephone, 3870 or 3871 Madison Square

H. E. FROMENT,
 Wholesale Commission Florist,
 Choice Cut Flowers,
 57 West 28th St., :: NEW YORK.
 Telephones: 2200, 2201, Madison Square.

The Reliable Commission House
 Richmond Roses and Rich Flowers
 of all varieties
JOS. S. FENRICH
 110 W. 28th Street, New York
 Tel. 324-325 Madison Square

Established 1891 BUY FROM SHIP TO TRY **ME**
ALFRED H. LANGJAHR
 All Choice Cut Flowers in Season
 55 West 28th St., New York
 Telephone 3924 Madison Square.

JOHN I. RAYNOR
Wholesale Commission Florist SELLING AGENT FOR LARGEST GROWERS
 A full line of Choice Cut Flower stock for all purposes. Comprised every variety grown for New York market, at current prices
 TEL. 1998 MADISON SQUARE 49 W. 28 St., New York City

Walter F. Sheridan
 Wholesale Commission Dealer in
CHOICE CUT FLOWERS
 39 West 28th Street, New York
 Telephone: 3532-3533 Madison Square

HEADQUARTERS FOR NOVELTIES
ORCHIDS A SPECIALTY
 THE HIGHEST GRADE OF **VALLEY** ALWAYS ON HAND
 GARDENIAS, DAISIES, ROSES AND CARNATIONS
JAMES McMANUS, Telephone 753 Mad. Sq. 42 W. 28th St., New York

PHILIP F. KESSLER 55 & 57 W. 26th St., New York City
 Commission Dealer, Wholesale Buyer and Seller of
CUT FLOWERS
 Open from 5 a. m. to 6 p. m. Sunday till 10 a. m.
 Tel. 5243 and 2921 Madison Sq. Res., 345 J., Newtownp.
Finest Lilies in the Market Every Day in the Year.

WHOLESALE COMMISSION FLORIST **J. K. ALLEN** 106 W. 28 ST. NEW YORK
 Telephone 167 Madison Sq.
 OPEN 6 A.M. DAILY
 We have a good regular outlet for seasonable flowers

NEW YORK QUOTATIONS PER 100—TO DEALERS ONLY

	Last Half of Week ending Feb. 1 1908	First Half of Week beginning Feb. 3 1908		Last Half of Week ending Feb. 1 1908	First Half of Week beginning Feb. 3 1908
Roses			Cattleyas	25.00 to 50.00	25.00 to 50.00
Am. Beauty, fan and sp.	30.00 to 60.00	30.00 to 75.00	Cypripediums	6.00 to 8.00	6.00 to 8.00
" extra	15.00 to 20.00	15.00 to 20.00	Lilies	8.00 to 10.00	8.00 to 10.00
" No. 1	12.00 to 15.00	12.00 to 15.00	Lily of the Valley	1.00 to 4.00	1.00 to 4.00
" Lower grades	1.00 to 2.00	1.00 to 2.00	Freezia	1.00 to 2.00	1.00 to 2.00
Bride, 'Maid, fan and sp.	8.00 to 12.00	8.00 to 12.00	Roman Hy., Paper White Nar.	1.00 to 2.00	1.00 to 2.00
" extra	5.00 to 6.00	5.00 to 6.00	Daffodils	1.00 to 2.00	1.00 to 2.00
" lwr. grds.	1.00 to 3.00	1.00 to 3.00	Tulips	1.00 to 2.00	1.00 to 2.00
Killarney, Richmond, fancy & spec	10.00 to 15.00	10.00 to 15.00	Mignonette	2.00 to 5.00	2.00 to 5.00
" lower grades	2.00 to 4.00	2.00 to 4.00	Gardenias	10.00 to 25.00	10.00 to 25.00
Chatenay, Wellesley, fan, and spec.	8.00 to 10.00	8.00 to 10.00	Lilac per bunch	1.00 to 2.00	1.00 to 2.00
" lower grades	1.00 to 3.00	1.00 to 3.00	Sweet Peas	1.00 to 1.50	1.00 to 1.50
Golden Gate, Ivory	1.00 to 6.00	1.00 to 6.00	Adiantum	8.00 to 10.00	8.00 to 10.00
Carnations, Fancy and Novelties	2.00 to 4.00	2.00 to 4.00	Smilax	25.00 to 40.00	25.00 to 40.00
" Ordinary	1.00 to 2.00	1.00 to 2.00	Asparagus Plumosus, strings	10.00 to 15.00	10.00 to 15.00
Violets	.40 to .60	.40 to .60	" " & Spreo. (100 bchs.)		

B. S. SLINN, Jr.
 —WHOLESALE FLORIST—
 55 & 57 W. 26th St., New York City
 Tel., 3804 Madison Sq. Shipping Orders Solicited.
VIOLETS **Roses and**
 Carnations

Edward C. Horan
Wholesale Florist
 55 WEST 28th ST.
 Tel. 1462 1463 Madison Square New York

TRAENDLY & SCHENCK
WHOLESALE FLORISTS
 Furnish best stock at fair prices all the year round Send for quotations on fall orders
 Tel. 798-799 Madison Sq. 44 West 28th Street, New York City

Alexander J. Guttman
THE WHOLESALE FLORIST OF NEW YORK
43 WEST 28th STREET
PHONES. 1664-1665 MADISON SQUARE
ENOUGH SAID



HARDY CUT FERNS

Sphagnum Moss, Extra Large Bales, per bale, \$1.25. Fancy and Dagger Ferns our specialty. A trial order will convince you that we ship only first-class stock. Headquarters for Florists' supplies and wire work. All cut flowers in season. **BOXWOOD**, per bunch 35c, 50 lbs. \$7.50.

MICHIGAN CUT FLOWER EXCHANGE, INC., All 'phone connections **38-40 Broadway, Detroit, Mich.**

FANCY and DAGGER
Extra fine, \$1.50 per 1000. Bronze and Green Galax, \$1.25 per 1000. Leucothoe Sprays, \$1.00 per 100, \$7.50 per 1000.

WHOLESALE FLORISTS
54 West 28th St.
NEW YORK
Telephone 3559 Madison Sq.

A. L. YOUNG & CO.

**RECEIVERS & SHIP-
PERS OF CUT
FLOWERS.**
CONSIGNMENTS SOLICITED.

Headquarters in Western New York
FOR
ROSES, CARNATIONS
And all kinds of Seasonable Flowers

Wm. F. Kasting Co.

Wholesale Commission Florist, also Dealer in
Florists' Supplies and Wire Designs.

**383-87 ELLICOTT ST.
BUFFALO, N. Y.**

Give us a trial. We can please you.

FRANK S. HICKS & CO.

Wholesale Florists.

Open Now for Consignments of Cut Flowers.

52 West 28th Street, - New York City
Tel. 2920 Mad. Sq.

FRANK MILLANG

Wholesale Florist

Telegraphic Orders Filled and Delivered.

55-57 West 26th St., New York City.

Charles Millang

50 West 29th St., New York City

Cut Flowers on Commission

A Reliable Place to Consign to or order from
Telephone: 3860-3871 Madison Square

A. MOLTZ

Will purchase flowers on order in
N. Y. market and ship carefully at
prevailing wholesale prices. Address

55-57 West 26th Street, New York City

Best Flowers IN THE BOSTON MARKET

N. F. McCarthy & Co.

84 Hawley St., BOSTON, MASS.

Send for Prices

HENRY M. ROBINSON & CO.

WHOLESALE COMMISSION FLORISTS

Finest Grades of Roses, Carnations, Chrysanthemums, Lily of the Valley, Violets, etc.

15 Province St. & 9 Chapman Pl., Boston, Mass.

See our Fern ad.

WHOLESALE FLOWER MARKETS. — PER 100. — TO DEALERS ONLY.

	CINCINNATI Feb. 4	DETROIT Feb. 4	BUFFALO Feb. 4	PITTSBURG Feb. 4
ROSES				
Am. Beauty, Fan, and Sp.	30.00 to 40.00	50.00 to 65.00	40.00 to 50.00	30.00 to 40.00
" Extra	20.00 to 25.00	25.00 to 30.00	20.00 to 30.00	20.00 to 25.00
" No. 1	10.00 to 15.00	20.00 to 25.00	15.00 to 20.00	10.00 to 15.00
Lower grades	4.00 to 8.00	6.00 to 15.00	5.00 to 10.00	4.00 to 5.00
Bride, 'Maid, F. & S.	6.00 to 10.00	10.00 to 12.00	10.00 to 15.00	10.00 to 12.00
" Extra	6.00 to 8.00	8.00 to 10.00	8.00 to 10.00	8.00 to 10.00
" Low. gr.	4.00 to 5.00	6.00 to 8.00	4.00 to 6.00	4.00 to 6.00
Killarney, Richmond, Fan, & Sp.	10.00 to 15.00	8.00 to 10.00	10.00 to 15.00	12.00 to 15.00
" Lower grades	6.00 to 8.00	6.00 to 8.00	6.00 to 8.00	8.00 to 10.00
Chatenay, Wellesley, Fan & Sp.	8.00 to 10.00	8.00 to 10.00	12.00 to 15.00	10.00 to 12.00
" Lower grades	6.00 to 8.00	6.00 to 8.00	6.00 to 10.00	6.00 to 8.00
Golden Gate, Ivory	6.00 to 8.00	8.00 to 10.00	4.00 to 10.00	6.00 to 8.00
CARNATIONS				
Fancy and Novelties	4.00 to 5.00	4.00 to 5.00	3.00 to 4.00	3.00 to 4.00
Ordinary	2.00 to 3.00	2.00 to 4.00	2.00 to 3.00	2.00 to 3.00
MISCELLANEOUS				
Violets	50 to 75	1.00 to 1.50	.50 to 1.00	.50 to 1.00
Cattleyas	30.00 to 60.00	34.00 to 50.00	30.00 to 40.00	30.00 to 60.00
Cypripediums	12.00 to 15.00	8.00 to 10.00	10.00 to 15.00	10.00 to 15.00
Lilies	12.50	20.00 to 25.00	4.00 to 15.00	10.00 to 15.00
Lily of the Valley	3.00 to 4.00	3.00 to 4.50	3.00 to 4.00	3.00 to 4.00
Freesia	10.00	10.00 to 12.00	2.00 to 3.00	10.00 to 12.00
Roman Hy., Paper White Nar.	10.00 to 3.00	3.00 to 4.00	2.00 to 3.00	1.00 to 3.50
D. buds.	10.00	10.00 to 12.00	2.00 to 3.00	10.00 to 12.00
Tulips	10.00	10.00 to 12.00	2.00 to 3.00	10.00 to 12.00
Mignonette	10.00	8.00 to 10.00	3.00 to 5.00	2.00 to 4.00
Sweet Peas	10.00	10.00 to 12.00	3.00 to 5.00	10.00 to 12.00
Adiantum	1.00 to 2.00	1.00 to 2.00	1.00 to 1.50	1.00 to 1.20
Smilax	10.00 to 12.50	15.00 to 20.00	15.00 to 20.00	10.00 to 15.00
Asparagus Plumosus, strings	40.00 to 50.00	50.00 to 75.00	50.00 to 60.00	30.00 to 50.00
" & Spreu (100 bchs.)	25.00 to 35.00	30.00 to 40.00	25.00 to 50.00	30.00 to 60.00

SAMUEL A. WOODROW

WHOLESALE PLANTSMAN

Palms, Large and Small Ferns, etc.

53 West 30th Street, NEW YORK

Telephone 2083 Madison

WILLIAM H. KUEBLER

Brooklyn's Foremost and Best

WHOLESALE COMMISSION HOUSE

A First Class Market for all CUT FLOWERS

28 Willoughby St., Brooklyn, N. Y.

Tel. 4591 Main

GLEARY'S HORTICULTURAL CO.

Management AMEROSÉ T. GLEARY

Wholesale Contracting, Jobbing, Auction

HORTICULTURAL PRODUCTS

of every description.

Consignments Received. Surplus Stock Converted.

62 Vesey St., NEW YORK

Moore, Hentz & Nash,

Wholesale Commission Florists,

55 and 57 West 26th Street,

Telephone No. 756
Madison Square.

New York.

H. C. BERNING

Wholesale Florist

1402 Pine Street, ST. LOUIS, MO.

Alex Mann, Jr. Co. Inc.

Wholesale Dealer in

Florists' Supplies and Cut Flowers

White Doves, \$9.00 per doz.
Galax Leaves.

1125 Polk Street, San Francisco, Cal.

J. B. Murdoch & Co.

Wholesale Florists

FLORISTS' SUPPLIES

714 Penn Ave., PITTSBURG, PA.

Long Distance 'Phone 1435 Court.

REED & KELLER

122 West 25th St., New York

Florists' Supplies

We manufacture all our

Metal Designs, Baskets, Wire Work & Novelties

and are dealers in

Glassware Decorative Groceries and Florists' Requisites.

Buyer's Directory and Ready Reference Guide

Advertisements under this head, one cent a word. Initials count as words.

Regular advertisers in this issue are also listed under this classification without charge. Reference to List of Advertisers will indicate the respective pages.

Buyers failing to find what they want in this list will confer a favor by writing us and we will try to put them in communication with reliable dealers.

ACCOUNTANT

R. J. Dysart, 28 State St., Boston.
For page see List of Advertisers.

ALTERNANTHERAS

Red Alternantheras at 40 cents per 100.
C. W. Moeckel, 17 Summer St., Fitchburg, Mass.

AQUARIUMS

Aquarium plants the year round. Wholesale and retail. Send for price list Schmid's Emporium of Pets, 712 12th Street, Washington, D. C.

ARAUCARIAS

Godfrey Aschmann, 1012 Ontario St., Philadelphia, Pa.
For page see List of Advertisers.

ARTIFICIAL CALYX

Maxfield & Dimond, Warren, R. I.

ASPARAGUS

Asparagua Sprengerii, field grown, \$4.00 and \$6.00 per 100. C. Winterlich, Defiance, Ohio.

Asparagus Plumosa, 2 in. pots. Fine plants, \$2.00 per 100; \$25.00 per 1000. Cash with order or good reference. Erie Floral Co., Erie, Pa.; or, Wm. F. Kasting Co., 385 Elliott St., Buffalo, N. Y.

AUCTION SALES

Cleary's Horticultural Co., 62 Vesey St., New York.
Horticultural Products of Every Description.
For page see List of Advertisers.

Sales every Tuesday and Friday. If you cannot attend send bids and shipping instructions. Catalogues on application. N. F. McCarthy & Co., 84 Hawley St., Boston.

AZALEAS

A. Leuthy & Co., Perkins St. Nurseries, Roslindale, Mass.
For page see List of Advertisers.

W. W. Edgar Co., Waverley, Mass.
For page see List of Advertisers.

August Rolker & Sons, New York, 31 Barclay St., or P. O. Box 752.
For page see List of Advertisers.

Bobbinck & Atkins, Rutherford, N. J.

BAMBOO CANES

Stump & Walter Co., 50 Barclay St., New York.
For page see List of Advertisers.

Yokohama Nursery Co., 31 Barclay Street, New York.
For page see List of Advertisers.

BAY TREES.

Specimens and pairs, all sizes. Send for prices. N. F. McCarthy & Co., 84 Hawley St., Boston.

Bay Trees and Box Trees, standards and pyramids. All sizes. Price list on application. J. Roehrs Co., Rutherford, N. J.

BEGONIAS

Wm. Elliott & Sons, 201 Fulton St., New York.

BOILERS

BOILERS. "Burnham" Boilers made for greenhouse heating. Lord & Burnham, 1133 Broadway, N. Y.

BOXWOOD

A. Leuthy & Co., Perkins St. Nurseries, Roslindale, Mass.
For page see List of Advertisers.

Henry M. Robinson & Co., 15 Province St., Boston.
For page see List of Advertisers.

BUILDING MATERIAL

BUILDING MATERIAL of all description for All Cypress, Semi-Iron, Iron Frame or Truss Houses, Hot Bed Sash and Frames. Lord & Burnham Co., 1133 Broadway, N. Y.

BULBS AND TUBERS

Joseph Breck & Sons, 47-54 N. Market St., Boston.
For page see List of Advertisers.

J. M. Thornburn & Co., 33 Barclay St., New York.
For page see List of Advertisers.

A. T. Boddington, 342 W. 14th St., N. Y.
For page see List of Advertisers.

Rickards Bros., 37 East 19th St., New York.
For page see List of Advertisers.

H. F. Mitchell Co., Philadelphia.
For page see List of Advertisers.

H. E. Fliske Seed Co., Faneuil Hall Sq., Boston.
For page see List of Advertisers.

James Vick's Sons, Rochester, N. Y.
Pall Bulbs.
For page see List of Advertisers.

D. Rusconi, 128 W. Sixth St., Cincinnati, O.
Lilium Auratum, Roseum, Multiflorum.
For page see List of Advertisers.

Aug. Rolker & Sons, 31 Barclay St., New York.
Seasonable Import Plants and Bulbs.
For page see List of Advertisers.

K. Velthuys, Hillezom, Holland,
Represented by Felix Bosch, 260 Clarendon St., Boston.

Bulbs French and Dutch.
For page see List of Advertisers.

John Scheepers & Co., 4 and 6 Old Slip, New York.
Lily of the Valley Excellenta.

Dwarf Pearl tuberosc, 50,000 No. 2, very fine bulbs, 4 in. in circumference. Write for prices. T. V. Rivenbark, Wallace, N. C.

CANNAS

The Conard & Jones Co., West Grove, Pa.
For page see List of Advertisers.

Good Robusta, dark leaved, at \$1.50 per 100; large clumps Burbank, White Peral and Chimbar, at \$2.00 per 100; Pennsylvania, at \$2.50 per 100. C. W. Moeckel, 17 Summer St., Fitchburg, Mass.

CARNATIONS

Field Grown

The H. Weber & Sons Co., Oakland, Md.
Seedling Carnation Toreador.
For page see List of Advertisers.

CARNATIONS—Continued Rooted Cuttings

F. Dorner & Sons Co., Lafayette, Ind.
For page see List of Advertisers.

S. S. Skidelsky, 1741 N. 18th St., Philadelphia.
For page see List of Advertisers.

Chicago Carnation Co., Joliet, Ill.
For page see List of Advertisers.

F. R. Pierson Co., Tarrytown, N. Y.
Winsor and White Enchantress Rooted Cuttings.

For page see List of Advertisers.

H. A. Jahn, New Bedford, Mass.
Carnation Lloyd.

For page see List of Advertisers.

F. H. Kimberly, 631 Townsend Ave., New Haven, Conn.
For page see List of Advertisers.

John E. Haines, Bethlehem, Pa.
Carnations Imperial and Pink Imperial.
For page see List of Advertisers.

Welch Bros., 226 Devonshire St., Boston.
Carnation White Fair Maid.
For page see List of Advertisers.

A. N. Pierson, Cromwell, Ct.
Carnation Winsor.

For page see List of Advertisers.

Charles H. Totty, Madison, N. J.
For page see List of Advertisers.

Guttman & Weber, 43 W. 25th St., New York.

John E. Haines, Bethlehem, Pa.
Carnations, Imperial and Pink Imperial.
For page see List of Advertisers.

Unrooted Lawson, Boston Market, \$5.00 per 1000; Hill, \$4.00 per 1000 Wm. Elmman, Jr., Corfu, N. Y.

CHRYSANTHEMUMS

W. W. Edgar Co., Waverley, Mass.
For page see List of Advertisers.

Charles H. Totty, Madison, N. J.

CONIFERS

John Waterer & Sons, Ltd., American Nursery, Hagshot, Eng.
For page see List of Advertisers.

Write for prices on all choice ornamental conifers. N. F. McCarthy & Co., 84 Hawley St., Boston, Mass.

CUT FLOWER BOXES.

Edwards Folding Box Co., Philadelphia.
For page see List of Advertisers.

Getmore Box Factory, Inc., Belleville, Ala.
Light Wood Boxes.

For page see List of Advertisers.

Folding cut flower boxes, the best made. Write for list. Holton & Hunkel Co., Milwaukee, Wis.

DAHLIAS

David Herbert & Son, Atco, N. J.
For page see List of Advertisers.

J. L. Moore, Northboro, Mass.
For page see List of Advertisers.

DECORATIVE PLANTS

A. Leuthy & Co., Roslindale, Mass.
For page see List of Advertisers.

Jullus Roehrs, Rutherford, N. J.
For page see List of Advertisers.

Anton Schultze, College Point, N. Y.

Philadelphia Plant Exchange, 839 Market St., Philadelphia, Pa.

For List of Advertisers See Page 188

FERNS

- A. Leuthy & Co., Roslindale, Mass.
For page see List of Advertisers.
- H. H. Barrows & Son, Whitman, Mass.
Nephrolepis Whitman.
For page see List of Advertisers.
- Godfrey Aschmann, 1012 Ontario St., Philadelphia, Pa.
For page see List of Advertisers.
- John Scott, Brooklyn, N. Y.
For page see List of Advertisers.
- Barr Floral Co., Erie, Pa.
For page see List of Advertisers.
- Henry A. Dreer, Philadelphia, Pa.
Ferns for Dishes.
For page see List of Advertisers.
- Whitman ferns, 9 in., \$1.00; 8 in., 80c.
H. Ernst & Son, Washington, Mo.

FERTILIZERS

- Pulverized Manure Co., 31 Union Stock Yards, Chicago, Ill.
Wizard Brand Cattle Manure.
For page see List of Advertisers.
- Thos. J. Grey & Co., 32 and 33 South Market St., Boston.
High-Grade Scotch Soot.
For page see List of Advertisers.

FLORAL PHOTOGRAPHS

- Floral Photographs. Foley's 226-228 1-2 Bowery, New York.

FLORISTS' LETTERS.

- Boston Florist Letter Co., 66 Pearl St., Boston, Mass.
For page see List of Advertisers.
- Koral Mfg. Co., 26 Hawley St., Boston.
For page see List of Advertisers.

FLORISTS SUPPLIES

- H. M. Robinson & Co., 15 Province St. and 9 Chapman Pl., Boston, Mass.
For page see List of Advertisers.
- The Kervan Co., 113 W. 28th St., N. Y.
Decorative Evergreens.
For page see List of Advertisers.
- Reed & Keller, 122 W. 25th St., New York.
For page see List of Advertisers.
- J. B. Murdoch & Co., 545 Liberty St., Pittsburg, Pa.
For page see List of Advertisers.
- H. Bayersdorfer & Co., 1129 Arch St., Philadelphia.
For page see List of Advertisers.
- Alex. Mann, Jr., Co., 1125 Polk St., San Francisco, Calif.
For page see List of Advertisers.

FLOWERS BY TELEGRAPH

- Park Floral Co., Denver, Colo.
For page see List of Advertisers.
- J. N. Champion & Co., 1026 Chapel St., New Haven, Conn.
For page see List of Advertisers.
- George H. Cooke, Washington, D. C.
For page see List of Advertisers.
- Gude Bros. Co., 1214 F St., Washington, D. C.
For page see List of Advertisers.
- Atlanta Floral Co., Atlanta, Ga.
For page see List of Advertisers.
- P. J. & J. E. Hauswirth, 232 Michigan Ave., Chicago.
For page see List of Advertisers.
- William J. Smyth, Michigan Ave. and 31st St., Chicago.
For page see List of Advertisers.
- Jacob Schulz, 644 4th Ave., Louisville, Ky.
For page see List of Advertisers.
- Thos. F. Galvin, 124 Tremont St., Boston.
For page see List of Advertisers.
- Julius A. Zinn, 2 Beacon St., Boston.
For page see List of Advertisers.

FLOWERS BY TELEGRAPH—

Continued

- Houghton & Clark, 396 Boylston St., Boston.
For page see List of Advertisers.
- Sidney Hoffman, 59-61 Massachusetts Ave., Boston.
For page see List of Advertisers.
- J. Brettmeyer's Sons, Miami and Gratiot Aves., Detroit, Mich.
For page see List of Advertisers.
- Samuel Murray, 1017 Broadway, Kansas City, Mo.
For page see List of Advertisers.
- Wm. L. Rock Flower Co., 1116 Walnut St., Kansas City, Mo.
For page see List of Advertisers.
- Fred C. Weber, 4326-28 Olive St., St. Louis, Mo.
For page see List of Advertisers.
- H. G. Eyres, 11 N. Pearl St., Albany, N.Y.
For page see List of Advertisers.
- David Clarke's Sons, 2159-2141 Broadway, New York.
For page see List of Advertisers.
- W. H. Donohoe, 17 E. 28th St., New York.
For page see List of Advertisers.
- Alex. McConnell, New York.
For page see List of Advertisers.
- Robert G. Wilson, Fulton St. & Greene Av., Brooklyn, N. Y.
For page see List of Advertisers.
- Thomas Young, Jr., 500 Fifth Ave., N. Y.
For page see List of Advertisers.
- Young & Nugent, 42 W. 28th St., N. Y.
For page see List of Advertisers.

FLOWER POTS

- W. H. Ernest, 28th and M Sts., Washington, D. C.
For page see List of Advertisers.
- A. H. Hews & Co., Cambridge, Mass.
For page see List of Advertisers.
- Hilfinger Bros., Ft. Edward, N. Y.
For page see List of Advertisers.

FORCING ROOTS

- Bobbin & Atkins, Rutherford, N. J.

GALAX

- Michigan Cut Flower Co., 38 and 40 Broadway, Detroit, Mich.
For page see List of Advertisers.
- Finest green and bronze Galax in any quantity at lowest figures. N. F. McCarthy, 84 Hawley St., Boston.

GERANIUMS

- R. Vincent Jr. & Sons Co., White Marsh, Md.
New and Standard Varieties.
For page see List of Advertisers.
- S. A. Nutt, Rooted Cuttings, at \$1.25 per 100. C. W. Moeckel, 17 Summer St., Fitchburg, Mass.

GLADIOLI

- Arthur Cowee, Meadowvale Farm, Berlin, New York.
For page see List of Advertisers.
- J. L. Moore, Northboro, Mass.
For page see List of Advertisers.
- Gladioli. Write for leaflet. B. Hammond Tracy, Cedar Acres, Wenham, Mass.
Gladioli Colvilli Alba, \$1.00 per 100; \$7.50 per 1000. Gladioli Rosea, \$1.25 per 100; \$9.00 per 1000. America, light pluk, immense flower, \$1.00 per doz.; \$7.50 per 100. Cushman Gladiolus Co., Sylvania, O.

GLASS

- Boston Plate & Window Glass Co., Boston
For page see List of Advertisers.
- Standard Plate Glass Co., 26-30 Sudbury St., Boston.
For page see List of Advertisers.
- Foley Mfg. Co., between Western Ave. and 26th St., Chicago, Ill.
- GLASS, High Grade, Double Thick Greenhouse Glass. Lord & Burnham, 1133 Broadway, N. Y.

GLAZING POINT

- H. A. Dreer, Philadelphia, Pa.
For page see List of Advertisers.
- GLAZING POINTS, Lord & Burnham Special Glazing Nails (Points). Lord & Burnham, 1133 Broadway, N. Y.

GREENHOUSE BUILDING MATERIAL.

- Lord & Burnham Co., 1133 Broadway, New York.
For page see List of Advertisers.
- Pierson U-Bar Co., 1 Madison Sq., N. Y.
For page see List of Advertisers.
- Hitchings & Co., 1170 Broadway, N. Y.
For page see List of Advertisers.
- A. T. Stearns Lumber Co., Neponset, Boston.
For page see List of Advertisers.
- King Construction Co., N. Tonawanda, New York.
For page see List of Advertisers.
- J. C. Moninger Co., 117 East Blackhawk St., Chicago, Ill.
For page see List of Advertisers.
- Foley Mfg. Co., between Western Ave. and 26th St., Chicago, Ill.
For page see List of Advertisers.
- I. Cassidy, Summer Ave. and Erie R. R., Newark, N. J.
For page see List of Advertisers.
- W. H. Lutton, Jersey City, N. J.
For page see List of Advertisers.
- S. Jacobs & Sons, 1365-79 Flushing Ave., Brooklyn, N. Y.
For page see List of Advertisers.
- Metropolitan Material Co., 1398-1408 Metropolitan Ave., Brooklyn, N. Y.

GREENHOUSE CONSTRUCTION

- GREENHOUSE CONSTRUCTION, Semi-Iron Greenhouse, New Truss Houses and Iron Frame Houses. Lord & Burnham, 1133 Broadway, N. Y.

- J. A. Payne, 260-274 Culyer Ave., Jersey City, N. J.
For page see List of Advertisers.

- I. Cassidy, Summer Ave. and Erie R. R., Newark, N. J.
For page see List of Advertisers.

- Foley Mfg. Co., between Western Ave. and 26th St., Chicago, Ill.

- W. H. Lutton, Jersey City, N. J.
For page see List of Advertisers.

GREENHOUSE HOSE

- Mineralized Rubber Co., 18 Cliff St., N. Y.
For page see List of Advertisers.

GUTTERS

- GUTTERS, Cast Iron Gutters, L. & B. Improved V Shaped Gutter with drip gutter attachment. Lord & Burnham, 1133 Broadway, N. Y.

HAIL INSURANCE

- Florists' Hail Asso. of America. J. G. Esler, Saddle River, N. J.
For page see List of Advertisers.

HARDY FERNS AND SUPPLIES

- H. M. Robinson & Co., 15 Province St. and 9 Chapman Pl., Boston, Mass.
For page see List of Advertisers.
- The Kervan Co., 113 W. 28th St., N. Y.
For page see List of Advertisers.
- Michigan Cut Flower Exchange, 38 and 40 Broadway, Detroit, Mich.
Fancy Ferns.
For page see List of Advertisers.

- A full line of ferns, galax, and all wild greens. N. F. McCarthy & Co., 84 Hawley St., Boston.

HARDY HERBACEOUS PLANTS

- Bay State Nurseries, N. Abington, Mass.
For page see List of Advertisers.
- New England Nurseries, Inc., Bedford, Mass.
For page see List of Advertisers.

In writing to Advertisers kindly mention Horticulture

HEATING APPARATUS

Lord & Burnham Co.,
1133 Broadway, New York.
For page see List of Advertisers.

Pierson U-Bar Co., 1 Madison Sq., N. Y.
For page see List of Advertisers.

Hitchings & Co., 1170 Broadway, N. Y.
For page see List of Advertisers.

John A. Payne, 260-274 Culver Ave., Jersey
City, N. J.
For page see List of Advertisers.

HELP FURNISHED

Thos. H. Raubrock, 31 S. 7th St., Phila.
For page see List of Advertisers.

HORICUM

Hammond's Paint & S. S. Wks., Fishkill-
on Hudson, N. Y.
For page see List of Advertisers.

HOT-BED SASH

The A. T. Stearns Lumber Co., Neponset,
Mass.
For page see List of Advertisers.

Pierson U-Bar Co., 1 Madison Sq., N. Y.
For page see List of Advertisers.

Hitchings & Co., 1170 Broadway, N. Y.
For page see List of Advertisers.

Lord & Burnham Co., 1133 Broadway, N. Y.
For page see List of Advertisers.

Foley Mfg. Co., between Western Ave. and
26th St., Chicago, Ill.

INSECTICIDES.

Nicotide kills all greenhouse pests.
P. R. Paethorpe Co.,
Eleventh St., Owensboro, Ky.
For page see List of Advertisers.

B. G. Pratt Co., 11 Broadway, New York.
For page see List of Advertisers.

For Sale—Tobacco Stems and Tobacco
Dust. Stems, 1-2c. per lb. in bale lots.
Dust, 2c. per lb. in case lots. Weight of
bale or case 300 to 400 lbs. each. S. R.
Levy, Binghamton, N. Y.

JAPANA CUT FLOWER HOLDER

M. V. Garnsey, 130 So. Walola Av., La
Grange, Ill. Dept. F.
For page see List of Advertisers.

KENTIAS

A. Leuthy & Co., Roslindale, Mass.
For page see List of Advertisers.

Godfrey Aschmann, 1012 W. Ontario St.,
Philadelphia.
For page see List of Advertisers.

LEADING RETAIL FLORISTS

Park Floral Co., Denver, Colo.
For page see List of Advertisers

George H. Cooke, Washington, D. C.
For page see List of Advertisers.

Gude Bros. Co., 1214 F St.,
Washington, D. C.
For page see List of Advertisers

Atlanta Floral Co., Atlanta, Ga.
For page see List of Advertisers.

P. J. & J. E. Hauswirth, 232 Michigan Ave.,
Chicago.
For page see List of Advertisers.

William J. Smyth, Michigan Ave. and 31st
St., Chicago.
For page see List of Advertisers

Jacob Schulz, 644 4th Ave., Louisville, Ky.
For page see List of Advertisers

Thos. F. Galvin, 124 Tremont St., Boston.
For page see List of Advertisers.

Julius A. Zinn, 2 Beacon St., Boston.
For page see List of Advertisers.

Houghton & Clark, 396 Boylston St.,
Boston.
For page see List of Advertisers.

Sidney Hoffman, 59-61 Massachusetts Ave.,
Boston.
For page see List of Advertisers.

J. Brettmeyer's Sons, Detroit, Mich.
For page see List of Advertisers.

LEADING RETAIL FLORISTS**Continued**

Samuel Murray, 1017 Broadway,
Kansas City, Mo.
For page see List of Advertisers.

Wm. L. Rock Flower Co., 1116 Walnut
St., Kansas City, Mo.
For page see List of Advertisers.

Fred C. Weber, 4326 Olive St., St. Louis,
Mo.
For page see List of Advertisers.

J. N. Champion & Co., 1026 Chapel St.,
New Haven, Conn.
For page see List of Advertisers.

H. G. Eyres, 11 N. Pearl St., Albany, N. Y.
For page see List of Advertisers.

David Clarke's Sons, 2139-2141 Broadway,
New York.
For page see List of Advertisers.

W. H. Dooehoe, 17 E. 28th St., New York.
For page see List of Advertisers.

Alex. McConnell, New York.
For page see List of Advertisers.

Robert G. Wilson, Fulton St. and Greene
Ave., Brooklyn, N. Y.
For page see List of Advertisers.

Thomas Young, Jr., 500 Fifth Ave., N. Y.
For page see List of Advertisers

Young & Nugent, 42 W. 28th St., N. Y.
For page see List of Advertisers

LOBELIAS

Jos. Fuller, 31 Orchard St., Leominster,
Mass.
Carter's Double Blue Lobelia.
For page see List of Advertisers.

NEW AND RARE PLANTS

Rose Hill Nurseries, New Rochelle, N. Y.
For page see List of Advertisers.

NICO-FUME

Kentucky Tobacco Product Co.,
Louisville, Ky.

NURSERY STOCK

John Waterer & Sons, Ltd.,
American Nursery, Bagshot, England.
For page see List of Advertisers.

New England Nurseries, Bedford, Mass.
Shrubs, Roses and Herbaceous Perennials.
Specimen Pyramidal Box.
For page see List of Advertisers.

Bay State Nurseries, N. Abington, Mass.
Herbaceous Perennials, Hardy Ornamental
Trees.
For page see List of Advertisers.

Cleary's Horticultural Co., 62 Vesey St.,
New York.
For page see List of Advertisers.

P. Ouwkerk, 216 Jane St., Weehawken
Heights, N. J.
Holland Nursery Stock for Forcing.
For page see List of Advertisers

American Nursery Co., 150 Broadway, New
York, N. Y.
For page see List of Advertisers.

Nurseries Stock, N. F. McCarthy & Co.,
84 Hawley St., Boston, Mass.

A. Van Leeuwen, Jr., H. H. De Wildt.
THE HORTICULTURAL CO.
Landscape Department, Office & Nurseries,
Worcester, Mass. Castle, N. C.
What have you got to sell?
We are buying.

ORCHID PLANTS

Lager & Hurrell, Summit, N. J.
For page see List of Advertisers.

Sander, St. Albans, England.
Importers, Exporters, Growers, Hybridists
For page see List of Advertisers.

Julius Roehrs Co., Rutherford, N. J.
For page see List of Advertisers.

Carrillo & Baldwin, Secaucus, N. J.
For page see List of Advertisers.

Jos. A. Manda, 191 Valley Road, W.
Orange, N. J.
For page see List of Advertisers.

Ordonez Bros., Madison, N. J., Box 105.
For page see List of Advertisers.

PALMS

A. Leuthy & Co., Perkins St. Nurseries,
Roslindale, Mass.
For page see List of Advertisers.

Robert Craig Co., Market and 49th Sts.,
Philadelphia, Pa.
For page see List of Advertisers.

Kentia, Phoenix, etc., all sizes. Write
for new price list. Julius Roehrs Co.,
Rutherford, N. J.

PAINT AND PUTTY

PAINT AND PUTTY: Ideal Greenhouse
lead; Special Greenhouse Putty. Lord &
Burnham, 1133 Broadway, N. Y.

PLANT PROTECTORS

J. H. Haley, Munith, Mich.
Concrete Plant Protector for Tomato
Growing.

PANSY PLANTS.

Choice pansy plants, 50c. per 100; \$4.00
per 1000. Cash. Aug. Zirnglebel, Need-
ham, Mass.

PATENTS

Siggers & Siggers, Washington, D. C.
For page see List of Advertisers.

PEAT

Orchid peat, Rotted peat, Azalea peat,
Leaf-Mould, Live Sphagnum moss, Baled
Sphagnum moss, Green Clump moss, etc.
Jobbers' list on application. C. W. Brown-
ell & Co., Walden, N. Y.

PEONIES

One of the finest collections in America.
Send 25 cts. in stamps for new edition of
Peony Manual. C. S. Harrison's Select
Nursery, York, Neb.

PETUNIAS

Henry A. Dreer, Philadelphia.
Superb Double Petunias.
For page see List of Advertisers.

PHLOXES

Send 25 cts. in stamps for Phlox Manual.
Fine mixed phloxes \$1.50 per 100. C. S.
Harrison's Select Nursery, York, Neb.

PIPE AND FITTINGS

Foley Mfg. Co., between Western Ave. and
26th St., Chicago, Ill.

PIPE AND FITTINGS. Cast Iron and
Wrought Pipe, Valves, Elbows, Pipe Hooks,
Automatic Air Headers, etc. Lord &
Burnham, 1133 Broadway, N. Y.

PLANT BED CLOTH

Mineralized Rubber Co., 18 Cliff St., N. Y.
For page see List of Advertisers.

POT HANGERS

Pot hangers, Kramer's \$1 doz. by exp.,
\$1.25 by mail. J. N. Kramer & Son, Cedar
Rapids, Ia.

PRUNING SHEARS

Rhodes Mfg. Co., Grand Rapids, Mich.
Dept. R.

RAFFIA

Raffia (colored), 20 beautiful shades.
Samples free. R. M. Coney Co., Camden,
N. J.; 810 Washburn Ave., Chicago, Ill.

RHODODENDRONS

John Waterer & Sons, Ltd.,
American Nursery, Bagshot, England.
For page see List of Advertisers.

ROSES

Julius Roehrs Co., Rutherford, N. J.
Rambler Rose, Newport Fairy.
For page see List of Advertisers.
New England Nurseries, Inc., Bedford,
Mass.
Roses for Forcing.
For page see List of Advertisers.

For List of Advertisers See Page 188

ROSES - Continued

- Bay State Nurseries, N. Abington, Mass.
Roses for Forcing.
For page see List of Advertisers.
- Ellwanger & Barry, Rochester, N. Y.
Hardy Roses.
For page see List of Advertisers.
- John Cook, 318 Charles St., N. Baltimore,
Maryland.
Rose My Maryland.
For page see List of Advertisers.
- Charles H. Totty, Madison, N. J.
Grafted Stock.
For page see List of Advertisers.
- Robert Craig Co., Market and 49th Sts.,
Philadelphia, Pa.
For page see List of Advertisers.
- Bobbink & Atkins, Rutherford, N. J.
A. N. Pierson, Cromwell, Conn.
Grafted and Own Root Roses.

400 varieties; own roots; summer grown.
Leddie Company, Springfield, Ohio.

Crimson Ramblers, 2 year, on own roots,
extra strong, at 7 cents. Gilbert Costich,
Rochester, N. Y.

Low-headed roses, No. 1, \$95.00; No.
11-2, \$65.00 1000. H. T. Jones, Elizabeth,
N. J.

SCALECID

B. G. Pratt Co., 11 Broadway, New York.
For page see List of Advertisers.

SEEDS

- T. J. Grey Co., 32 So. Market St.,
Boston, Mass.
For page see List of Advertisers.
- Joseph Breck & Sons,
51 and 52 N. Market St., Boston, Mass.
For page see List of Advertisers.
- W. Atlee Burpee & Co., Philadelphia.
For page see List of Advertisers.
- J. M. Thorburn & Co., 33 Barclay St., N. Y.
For page see List of Advertisers.
- A. T. Boddington, 342 W. 14th St., N. Y.
Vinca Seed.
For page see List of Advertisers.
- H. F. McBell Co., 1017 Market St., Phila.
For page see List of Advertisers.
- James Vlek's Sons, Rochester, N. Y.
Vlek's Superb Fanny Seed.
For page see List of Advertisers.
- Hjalmar Hartmann & Co.,
12 Stormgade, Copenhagen, Denmark.
Cauliflower and Cabbage Seed.
For page see List of Advertisers.
- Rickards Bros., 37 E. 19th St., New York.
For page see List of Advertisers.
- R. & J. Farquhar & Co., 6-7 So. Market
St., Boston.
Giant Cyclamen Seed.
For page see List of Advertisers.
- C. C. Morse & Co., 48-56 Jackson St.,
San Francisco, Cal.
For page see List of Advertisers.
- H. E. Flske Seed Co., Faneuil Hall Sq.,
Boston.
For page see List of Advertisers.
- Braslan Seed Growers Co., San Jose, Cal.
For page see List of Advertisers.
- O. V. Zangen, Hoboken, N. J.
For page see List of Advertisers.
- R. Wibholt, Nakskov, Denmark.
Snowball Cauliflower Seed.
For page see List of Advertisers.
- Sander & Son, Bruges, Belgium.
Cocos Weddelliana Seed.
For page see List of Advertisers.
- Crego aster seed. Ask for circular, G.
S. Crego, Maywood, Ill.

SMILAX

E. A. Beaven, Evergreen, Ala.
Southern Wild Smilax; Log Mosses.
For page see List of Advertisers.

SPHAGNUM MOSS

Live Sphagnum moss, orchid peat and
orchid baskets always on hand. Lager &
Hurrell, Summit, N. J.

STEAM TRAP

E. Hippard, Youngstown, O.

VENTILATING APPARATUS

- Pierson U-Bar Co., 1 Madison Sq., N. Y.
For page see List of Advertisers.
- Hitchings & Co., 1170 Broadway, N. Y.
For page see List of Advertisers.
- Foley Mfg. Co., between Western Ave. and
26th St., Chicago, Ill.
For page see List of Advertisers.
- John A. Payne, 260-274 Culver Ave., Jersey
City, N. J.
For page see List of Advertisers.
- VENTILATING MACHINERY, New
Model encased, self-oiling gear; Standard
Model Open Gear. Lord & Burnham, 1133
Broadway, N. Y.

VIOLETS

William Sim, Cliftondale, Mass.
Violet Boston.
For page see List of Advertisers.

WIREWOK

- Reed & Keller, 122 W. 25th St., N. Y.
For page see List of Advertisers.
- Wirework. Write for our catalogue.
Holton & Hunkel Co., Milwaukee, Wis.
- William E. Heitscher's Wire Works, 38-40
Broadway, Detroit, Mich.
- The "Just Right" kind. Send for price
list. Frank W. Ball, 31 East Third Street,
Cincinnati, O.

WHOLESALE FLORISTS

Boston

- N. F. McCarthy & Co., 84 Hawley St.,
Boston.
For page see List of Advertisers.
- H. M. Robinson & Co., 15 Province St.
and 9 Chapman Pl., Boston.
For page see List of Advertisers.
- Welch Bros., 226 Devonshire St., Boston.
For page see List of Advertisers.

Buffalo

Wm. F. Kasting Co., 383-87 Ellicott St.,
Buffalo, N. Y.
For page see List of Advertisers.

Chicago

- Chas. W. McKellar, 51 Wabash Ave.,
Chicago.
For page see List of Advertisers.
- Peter Reinberg, 51 Wabash Ave., Chicago.
For page see List of Advertisers.
- E. F. Winterson Co., 45-49 Wabash Ave.,
Chicago.
For page see List of Advertisers.

Detroit

Michigan Cut Flower Exchange, 38 and 40
Broadway, Detroit, Mich.
For page see List of Advertisers.

New York

- J. K. Allen, 106 W. 28th St., New York
For page see List of Advertisers.
- J. S. Fenrich, 110 W. 28th St., New York.
For page see List of Advertisers.
- Ford Bros., 48 W. 28th St., New York
For page see List of Advertisers.
- H. E. Froment, 57 W. 28th St., New York
For page see List of Advertisers.

Alex. J. Guttman, 43 W. 28th St., New
York.
For page see List of Advertisers.

E. C. Horan, 55 W. 28th St., New York
For page see List of Advertisers.

A. H. Langjahr, 55 W. 28th St., New York.
For page see List of Advertisers.

James McManus, 42 W. 28th St., New York.
For page see List of Advertisers.

WHOLESALE FLORISTS-

New York - Continued

- Chas Millang, 50 W. 20th St., New York.
For page see List of Advertisers.
- John I. Raynor, 49 W. 28th St., New York.
For page see List of Advertisers.
- W. F. Sheridan, 39 W. 28th St., New York.
For page see List of Advertisers.
- Traendly & Schenck, 44 W. 28th St., New
York.
For page see List of Advertisers.
- John Young, 51 W. 28th St., New York.
For page see List of Advertisers.
- Moore, Hentz & Nash, 55 and 57 W. 26th
St., New York.
For page see List of Advertisers.
- Frank S. Hicks & Co., 52 W. 28th St.,
New York.
For page see List of Advertisers.
- Frank Millang, 57 W. 26th St., New York.
For page see List of Advertisers.
- Wm. H. Kuehler, 28 Willoughby St.,
Brooklyn, N. Y.
For page see List of Advertisers.
- Philip F. Kessler, 55 and 57 W. 26th St.,
New York.
For page see List of Advertisers.
- A. Moltz, 55-57 W. 26th St., New York.
For page see List of Advertisers.
- B. S. Slinn, Jr., 55 W. 26th St., New York.
For page see List of Advertisers.
- A. L. Young & Co., 54 W. 28th St., New
York.
For page see List of Advertisers.

Philadelphia

- W. E. McKissick, 1221 Filbert St., Phila-
delphia, Pa.
For page see List of Advertisers.
- Leo Niessen Co., 1209 Arch St., Philadel-
phia, Pa.
For page see List of Advertisers.
- The S. S. Pennock-Meehan Co., 1608-18
Ludlow St., Philadelphia, Pa.
For page see List of Advertisers.
- Edward Reid, 1526 Ranstead St., Phila-
delphia, Pa.
For page see List of Advertisers.
- A. M. Campbell, 1510 Sansom St.,
Philadelphia.
For page see List of Advertisers.
- Wm. J. Baker, South Penn. Square,
Philadelphia, Pa.

Pittsburg

J. B. Murdoch & Co., 714 Penn Ave., Pitts-
burgh, Pa.
For page see List of Advertisers.

Providence, R. I.

J. Kopelman & Co., 21 Washington St.,
Providence, R. I.
For page see List of Advertisers.

San Francisco

Alex. Mann, Jr., Co., 1125 Polk St., San
Francisco, Cal.
For page see List of Advertisers.

St. Louis

H. G. Berning, 1402 Pine St., St. Louis, Mo.
For page see List of Advertisers.

Washington, D. C.

J. J. Hartz & Co., 1312 G. St. N. W.,
Washington, D. C.
For page see List of Advertisers.

WHOLESALE PLANT MARKET

Philadelphia Plant Exchange, 839 Market
St., Philadelphia.
For page see List of Advertisers.

WHOLESALE PLANTSMAN

Samuel A. Woodrow, 53 W. 30th St.,
New York.
For page see List of Advertisers.

In writing to Advertisers kindly mention Horticulture

List of Advertisers

Table listing advertisers and their page numbers. Includes entries like Allen J. K., American Nursery, Barracks Thos. H., etc.

New Offers in This Issue.

- BOXWOOD: GALAX: HARDY FERNIS. N. P. McCarthy & Co., 84 Hawley St., Boston. ... CANNAS. A. T. Boddington, 312 W. 14th St., New York. ... FLOWER SEEDS NEW CROP. Stump & Walter Co., 50 Barclay St., New York. ... FORMOSA LILIUM LONGIFLORUM. ? ? ? ... IRON PIPE. Geo. B. Deane, 18 Midway St., Boston. ... LINCOLN PANSY SEED. Wm. Elliott & Sons, 201 Fulton St., New York. ... PELARGONIUMS: GERANIUMS. R. Vincent, Jr. & Sons Co., White Marsh, Maryland.

OBITUARY.

Andrew DeVoe. Andrew DeVoe, son of the late Stuart De Voe, an old-time seedsman, died in New York on January 26.

Edward P. Stannard.

Edward P. Stannard of Westbrook, Conn., died on January 25, in his fifty-third year. About three years ago he started in the florist business in which he was very successful. He held many offices of trust in his town, and was highly esteemed. A widow and two daughters survive him.

John Awckland.

John Awckland, 67 years old, died on January 23 at his home in Frankford, Pa. Since 1864 he has been identified with the florist business in this town, and in 1887 his increasing business led him to locate on the Bartlett farm, where he erected several greenhouses. He leaves a widow, one daughter and three sons.

Responding to the constantly increasing demand from the farmers and land owners throughout Michigan for information regarding the planting and care of forest trees and the management of standing timber, the Agricultural College, through its department of forestry, will prepare planting and working plans for farm wood lots upon receiving application for such work from the owner.

Seedlings of the best native forest trees will be furnished to farmers from the college nurseries at cost. There are now on hand in the nursery seedlings of white and red pine, spruce, white cedar, western yellow pine, red oak, chestnut, post locust, tulip, walnut, butternut and ash; also cuttings of Carolina poplar, basket and white willow.

WANTS, FOR SALE, ETC.

Advertisements in this column one cent a word. Initials count as words. Cash with order. All correspondence addressed "care HORTICULTURE" should be sent to 11 Hamilton Place, Boston.

HELP WANTED

WANTED—SALESMAN

To Handle Good Side Line On Commission

One who calls on Florists, Seed Houses, Nurseries, Cemetery Superintendents, Monument Dealers, etc.

The Kramer Bros. Foundry Co. DAYTON, OHIO

HORTICULTURE needs a wide-awake representative in every town in the land. Good commission paid on advertising and subscriptions. If you are ambitious, write for terms.

SITUATIONS WANTED

GOOD MEN

When you need good men, skilled or unskilled, Write:

THOS. H. BAMBRICK

34 South 7th Street Philadelphia

Help of all kinds, including that for Florists, Nurserymen, Seedsmen and the Horticultural trade generally.

SITUATION WANTED as working foreman; understands growing roses, carnations, violets, chrysanthemums and miscellaneous plants. Aged 54; life experience in England and United States; single, English; 18 years in the United States. George H. Morris, Hudson Post Office, N. Y.

WANTED—Position in general greenhouse work; single; age 35; lifelong experience; understand every detail of growing, etc. Address P. A., care HORTICULTURE.

SITUATION WANTED in general greenhouse work; single, age 35, five years' experience, commercial. Address W. W., care HORTICULTURE.

FOR SALE

FOR SALE—Ten acres of fine soil for roses and carnations; five greenhouses recently built, heated with steam, boiler capable to heat three times as much glass. The houses are stocked with roses and anemones. Excellent railway facilities; 22 miles from Philadelphia. Price, \$4,500. Possession immediately or April 1. Address P. O. Box 77, North Wales, Pa.

FOR SALE—A large consignment of 16x24 double thick American glass, A and B quality. For further information write Parschelsky Brothers, 59 Montrose Avenue, Brooklyn, N. Y.

EXCHANGE

FOR EXCHANGE—First class Calla bulbs, one and two years old, for R. C. Carnations or Geraniums. W. J. Kingsbury, Derry, N. H.

Is Your Name In The Above List? If Not, Why Not?

A STAUNCH HOUSE.



We present herewith exterior and interior views of an iron-frame house erected last year by John A. Payne, Jersey City, for Stockton & Howe, Princeton, N. J. This house is 54 feet 6 inches wide and 317 feet long. The roof is supported on four lines of columns with the usual angle-iron pur-

proved satisfactory, much more so than if operated in very long lengths, affording better control over the heat of the house. Heating is done with one of Payne's large sectional boilers. Messrs. Stockton & Howe have expressed themselves as entirely satisfied with the operation of the plant



lins between the rafters, and is furnished with two lines of continuous roof ventilation, which are operated with self-locking worm and gear machinery. The worm rod extends down the columns at the sides, universal connections being used for the offsets in worm rod. The ventilation is arranged in 50-foot lengths, which has

and feel confident that they can easily maintain the temperature they desire in the coldest weather. They also state that there have not been three panes of glass broken during the year, apart from that broken through accident. This they consider exceptionally good, in view of the heavy storms the house has had to withstand.

EXEMPTING FOREST LANDS FROM TAXATION.

The encouragement of forestry is aimed at in a proposed amendment to the taxation laws brought before the taxation committee of Massachusetts by Assistant State Forester Cook, Representative Crane of Blackstone and Henry James, Jr., of Cambridge.

The present law allows a 10-year exemption from taxation on lands planted with trees at the ratio of 2000 to the acre. The bill advocated brings the number of trees down to 1200 and provides for a 20-year exemption.

CONTROLLING THE CODLING MOTH.

Oregon pear growers, who are greatly tormented by the codling moth, find the following scheme exceedingly useful: A selected tree is completely surrounded by a wire cage, in which the moths are confined. By careful observation of their development it is possible for the grower to know almost to an hour when he should begin to spray all his trees so as to destroy the moth without injuring the fruit.—Country Gentleman.

MISSOURI BOTANICAL GARDEN.

The annual financial report of the Board of Trustees of the Missouri Botanical Garden for the past year has been made public. Therein it is declared that the much-needed improvements at the gardens, such as the erection of new plant houses and an addition to the library, are seriously hindered by the outlay of money necessitated by street pavements, sidewalks and sewers laid in the streets adjacent to the garden tract. More than \$46,000 was expended in this way during the year, and it is estimated by the trustees that more than \$22,400 must be spent in the ensuing year for other public improvements. The total disbursements for the year amounted to \$171,974.26, and total receipts were \$170,360.32.

In ornamental bedding, 27,500 plants were used during the year. An increase of 10 per cent. in tulips used, an increase of 26 per cent. in variety of chrysanthemums and a total increase of 5 per cent. in plants of all kinds used are recorded for 1907.

An important Texas collection was studied, and forms the basis of an interesting pamphlet. More than 3300 books and pamphlets were added to the library and 58,668 new cards were placed in the index. The number of serial publications was extended to 1317, an increase of about 5 per cent.

The report recalls the appointment of Doctor Von Schrenk to the titular staff of the garden as plant pathologist.

LIST OF PATENTS.

Issued January 21, 1908.

- 876,951. Combined Roller and Harrow. Cordy C. Dollison, Lancaster, Ohio.
- 877,117. Insect Destroying Machine. Joseph Peil, Bloomer, Wis.
- 877,227. Manure Spreading Attachment for Wagons. Alexandra Turner and Lee Howard, Stillwell, Ill.
- 877,299. Grass Catcher for Lawn Mowers. Michael T. Curran, St. Louis, Mo.
- 877,316. Fertilizer Distributer. Edward F. Fisher, Atkinson, Neb.
- 877,359. Plow Point. Charles W. McWane, Lynchburg, Va., assignor to Lynchburg Foundry Co., Lynchburg, Va.
- 877,424. Combined Plow and Fertilizer Distributer. John B. Hicks, Wolf Pit Township, Richmond County, N. C.
- 877,434. Windmill. John H. Kappelman, Washington, Kan.
- 877,452. Harrow. William A. Preston, Roe, Ark.
- 877,469. Seeding Machine. William L. Paul, South Bend, Ind., assignor to Oliver Chilled Plow Works, South Bend, Ind.

I write to express my appreciation of your excellent publication during the past year and to say that I shall be very glad to have it continued during the coming new year of 1908, for which I wish you eminent success, prosperity and happiness.

H. A. SURFACE.
Harrisburg, Pa., Dec. 28, 1907.

A PROSPEROUS POTTERY.

A. H. Hews & Co., Inc., of Cambridge, Mass., are now running their plant at full capacity after a partial curtailment the past month due to heavy additions which they were obliged to make. Two new boilers, kilns, dynamo and special machinery for preparing clay have been installed, and their output has been greatly increased. The firm has maintained for some years a large warehouse in Long Island City, but has now opened a similar branch in Chicago to facilitate the handling of their western business.

This concern having constantly in mind the welfare and pleasure of its employes, has provided a large recreation room, 25x55 ft., with pool and billiard tables, various kinds of games and reading matter.

The outlook for a prosperous year is particularly bright and according to present indications this plant will be run to its full capacity during the season now opening.

GREENHOUSES BUILDING OR CONTEMPLATED.

Rockford, Ill.—M. C. Sadewater, three houses.

Milwaukee, Wis. Gustave Pohl, house 25x100.

New Orleans, La.—A. Most, three houses, 20x100.

New Lenox, Mass. H. H. Dewey, range of houses.

Charleston, S. C. Carolina Floral Co., range of houses.

Jamestown, N. Y.—Thomas Russell, three carnation houses.

E. Mansfield, Mass.—B. D. Vickery, cucumber house, 82 feet long.

The question of erecting a new city greenhouse at Sandusky, O., is again brought to the front and it is possible that Park Superintendent Roth's wishes may yet be acceded to and steps taken this season to provide the much-needed facilities.

NEW HEATING APPARATUS.

James Hamilton, Mt. Washington, Md., new 60 h. p. boiler.

The Misses Childs, New Canaan, Conn., Lord & Burnham boiler.

IRON PIPE

SECOND HAND

WROUGHT IRON PIPE, for Steam, Water, Gas or Oil, Fences or Posts. All Sizes. Price Low.

GEO. B. DOANE & SON
18 Midway Street, BOSTON
Telephone, Main 4419

BOSTON PLATE & WINDOW GLASS CO.

GREENHOUSE GLASS

German and American

261 to 287 A St., BOSTON 20-22 Canal St.

"SCALECIDE"

HAS MADE SPRAYING EASY THEN WHY NEGLECT YOUR TREES?

The N. Y. Herald, November 17, '07, says: "The chances are about a hundred to one that you have the San Jose Scale on your place and do not know it," and advises the use of "SCALECIDE." This is good advice. "SCALECIDE" has been tested and tried, and found thoroughly effective. The same yesterday, to-day, and all the time. One gallon makes 15 to 20, ready to use, by simply adding water.

Prices: 1 gal., \$1.00; 5 gal., \$3.25; 10 gal., 6.00; 50 gal. bbl., \$25.00, F. O. B. our factory. Order to-day. Write for booklet Wand free sample.

B. G. PRATT CO., Mfg. Chemists,
11 Broadway, New York City.

"HORICUM"

TRADE MARK

"HORICUM"

KILLS SAN JOSE SCALE

Directions for Use.

This preparation is Lime, Sulphur and Salt, making a concentrated Poly-sulphide of Calcium. The Salt adds to the adhesive properties, but the destructiveness to Scale Life lies in the Calcium Sulphide. Aside from its ability to destroy San Jose Scale, Horicum is a Fungicide, preventing the free development of fungoid troubles.

Shake package thoroughly or take the top off. The color in its concentrated form is a deep bronze green. Do not pour off the clear liquor only, stir the Horicum from the bottom of the package, add 20 parts of water (hot, if you can get it) for ordinary use. For a stronger dilution when the growth is all dormant, use 10 parts of water only (hot, if you have it) and spray thoroughly. By grading your dilution you make it any desired strength. Specific gravity, 1.56. Total Poly-sulphides, 25% by weight. Send for pamphlets to

HAMMOND'S SLUG SHOT WORKS
Fishkill-on-Hudson, N. Y.

Kills San Jose

HEATING THE GREENHOUSE

thoroughly and economically during the coming Winter is the problem now engrossing the mind of the Florist who takes time by the forelock.

I am in a position to help you to the best solution of this problem, I have done it for others, I can do it for you.

It will be to your advantage to consult me and get quotations on your heating plant either erected complete or for material ready for erection.

I have the largest line of C. I. and steel greenhouse boilers on the market and can give prompt shipments.

WRITE ME TO-DAY.

John A. Payne

Horticultural Architect and Builder
Main Office and Factory:
260 274 Culver Ave., Jersey City, N. J.
Sash opening apparatus and all kinds of greenhouse structural material.

The Best Bug Killer and Bloom Saver

NICOTICIDE BUG KILLER

For PROOF Write to

P. R. Palethorpe Co.
OWENSBORO, KY.

STANDARD FLOWER POTS

Packed in small crates, easy to handle.

1500 2 in. pots in crate \$4.88	120 7 in. pots in crate \$4.20
1500 3 1/4 " " " 5.25	60 8 " " " 3.00
1500 2 1/2 " " " 6.00	HAND MADE
1000 3 " " " 5.00	48 9 in. pots in crate \$3.60
800 3 1/2 " " " 5.80	48 10 " " " 4.80
500 4 " " " 4.50	24 11 " " " 3.60
320 5 " " " 4.51	24 12 " " " 4.80
144 6 " " " 3.16	12 14 " " " 4.80
	6 16 " " " 4.50

Seed pans, same price as pots. Send for price list of Cylinders for Cut flowers, Hanging Baskets, Lawn Vases, etc. Ten per cent. off for cash with order. Address Hillinger Bros., Pottery, Fort Edward, N. Y. August Rolker & Sons, Agts., 81 Barclay St., N. Y. City.

Standard Flower POTS

If your greenhouses are within 500 miles of the Capitol, write us, we can save you money

W. H. ERNEST,
28th and M Street WASHINGTON D. C.

Cattle Manure In Bags Shredded or Pulverized

Best and safest manure for florists and greenhouse use, absolutely pure, no waste, no danger. Write for circulars and prices.

The Pulverized Manure Co.,
31 Union Stock Yards, Chicago

ESTAB. 1765

A. H. HEWS & CO.

NO. CAMBRIDGE MASS. L. I. CITY N. Y.

CATALOGUE FREE

The FLORISTS' HALL ASSOCIATION OF AMERICA, insurer of 28,000,000 sq. ft. of glass. For particulars address **John C. Esler, Sec'y, Saddle River, N. J.**

WILLIAM H. LUTTON

HORTICULTURAL ARCHITECT AND BUILDER

WEST SIDE AVENUE STATION (C. R. R. OF N. J.)
JERSEY CITY, N. J.

Have not been established 50 years, but long enough to convince the wide-awake Florist and Gardener that it is to his interest to place his work in thoroughly practical hands.

(150,000 sq. ft. glass erected in 1907 will substantiate this claim)

And why not? My material is the best that can be secured. My iron frame construction has every modern feature that years of practical experience can embody.

AND THEN THERE IS THE COST TO BE CONSIDERED.

Why not let us take up this important question now?

GREENHOUSE GLASS

Cheaper Now Than For Years

We are taking contracts for next Spring delivery.

WRITE FOR OUR PRICES

STANDARD PLATE GLASS COMPANY

26-30 Sudbury St. 61-63 Portland St.
 BOSTON, MASS.

CYPRESS SASH BARS 82 feet or longer
HOT BED SASH
PECKY CYPRESS BENCH LUMBER

GREENHOUSES

ERECTED AND EQUIPPED COMPLETE IF DESIRED

Write for Circular "D" and Prices

The A. T. STEARNS LUMBER CO.
 NEPONSET, BOSTON, MASS.

S. JACOBS & SONS
 Manufacturers of GULF CYPRESS

GREENHOUSE MATERIAL
 HOT-BED-SASH & FRAMES
 Jobbers in **Boilers-Pipe-Fittings** and
GLASS on which we can quote attractive prices
 We furnish everything for Greenhouse Building
1365-1379 Flushing Avenue
BROOKLYN, - NEW YORK

GREENHOUSE MATERIAL AND FITTINGS

WRITE FOR PRICES

"1908 MODEL" VENTILATING MACHINE

SIMPLEST AND MOST DURABLE MACHINE
 NOW ON THE MARKET; EASILY ERECTED

I. CASSIDY,
 DESIGNER AND BUILDER

Summer Ave. & Erie R. R.
 NEWARK, - - - N. J.

NOW IS THE
 RIGHT TIME
 TO FIGURE

MATERIAL

AND PLAN FOR
 THE BUILDINGS
 OF THIS YEAR

FOLEY'S

QUALITY AND WORK THE BEST
 PRICES RIGHT AND LOWEST.
 ESTIMATES WILL PROVE. TRY US.

Foley Ventilating Apparatus Unequaled

Will Ventilate any Size of House Easily. Send for Circular.

THE FOLEY MFG. CO. Western Ave. 25th & 26th Sts. **CHICAGO**

ANCHOR GREENHOUSE HOSE

WEARS WELL.

PLANT BED CLOTH

Protects from Cold and Dampness.

MINERALIZED RUBBER CO.

18 Cliff Street New York

GREENHOUSE CONSTRUCTION LUMBER

John C. Moninger Co.
 117 E. Blackhawk St., CHICAGO

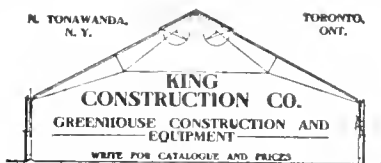

PATENTS

Trademarks and
 Copyrights

Send other business direct to Washington.
 Saves time and insures better service.
 Personal attention guaranteed.
 Twenty-five years' active service.
 SPECIALTY: "Working on the Failures
 of Others."

SIGGERS & SIGGERS

PATENT LAWYERS

Box 9, National Union Building
 Washington, D. C.

Holds Glass Firmly FULL SIZE No. 2

See the Point 

PEERLESS

Glassing Points are the best
 No rights or lefts. Box 1
 1,000 points 75 cts. postpaid

HENRY A. DERR
 714 Chestnut St. Phila. Pa.

In ordering goods please add, "I saw it in HORTICULTURE"

H AND C

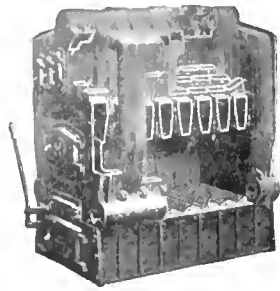

THERE IS ALWAYS
One that is Best

DON'T

EXPERIMENT, buy our
Sectional Boiler

Send for Catalogue

HITCHINGS & CO.

1170 Broadway
NEW YORK

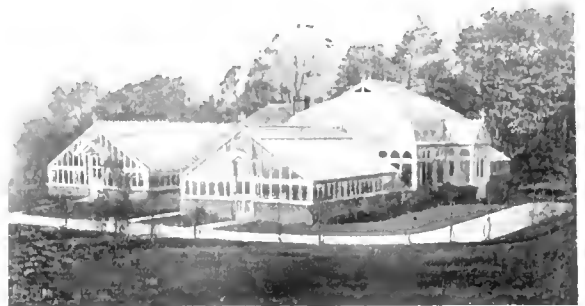

THE HOUSE OF
"Increased Efficiency"

The L. & B. *Sectional Iron Frame Houses*, whether for private places or among the florists, are today being run at less expense, and yielding greater returns than other constructions. It is because of their unequalled durability and "increased efficiency." Send for circular which tells why.

WE MAKE EVERY PART OF A GREENHOUSE BUT THE GLASS. WE SELL ANY PART.

LORD & BURNHAM CO.

1133 BROADWAY, cor. 26th Street, N. Y.
BOSTON Branch: 810 Tremont Building
PHILADELPHIA Branch: 1215 Filbert St.

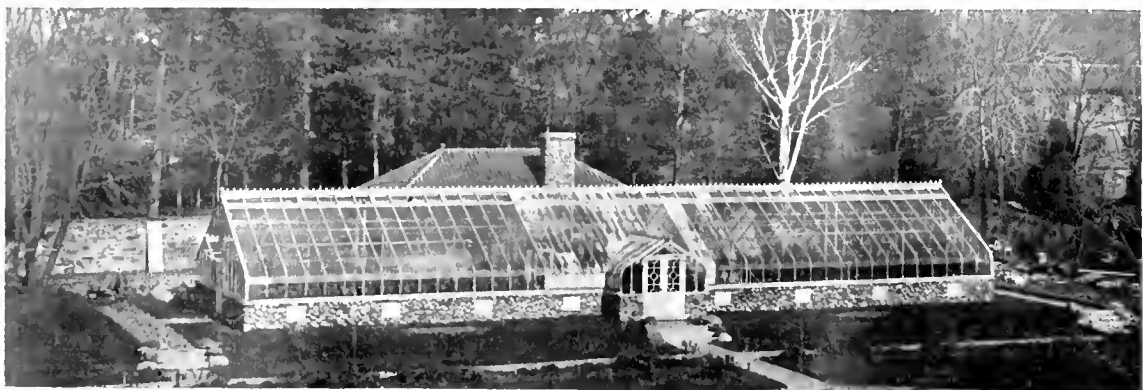

The Greatest Growing Houses

The U-Bar Greenhouse is absolutely different from any other construction. It is a construction built on entirely different lines, from top to bottom. A construction that makes a house of unequalled lightness, producing the best possible growing conditions. The catalog goes into every detail. Send for it.



U-BAR GREENHOUSES

PIERSON U-BAR CO.

Designers and Builders

1 Madison Avenue, New York

HORTICULTURE

Vol. VII.

FEBRUARY 15, 1908

No. 7



PRIMULA ACAULIS

*Devoted to the
FLORIST, PLANTSMAN,
LANDSCAPE GARDENER,
and
Kindred Interests*

*Published
EVERY SATURDAY
At 11 Hamilton Place,
BOSTON, MASS.
Subscription, \$1.00*

CANNA BULBS

Fine plump, Northern Grown, and in fine condition. Not to be compared with Southern grown stock, that are never thoroughly ripened and therefore are very slow to start growing.

	Doz.	100	1000		Doz.	100	1000
Allemania	\$0.35	\$2.50	\$22.50	Gladiator	\$0.40	\$3.00	\$27.00
Black Prince	.40	3.00	27.00	King Edward	.50	3.50	32.00
Black Warrior	.35	2.50	22.50	Louisiana	.55	4.00	35.00
Burbank	.30	2.25	20.00	Mad. Crozy	.40	3.00	27.00
Black Musafolia	.40	3.00	27.00	Mlle. Berat	.30	2.25	20.00
Charles Henderson	.35	2.50	22.50	Musafolia	.30	2.25	20.00
Director Roelz	.35	2.50	22.50	Paul Marquant	.30	2.25	20.00
Flamingo	.30	2.25	20.00	Pres. McKinley	.35	2.50	22.50
Florence Vaughan	.35	2.50	22.50	Queen Charlotte	.35	2.50	22.50
Golden Star	.30	2.25	20.00	Robusta	.30	2.00	18.00
				Red Cross	.30	2.25	20.00

STUMPP & WALTER CO., 50 Barclay St., NEW YORK

PELARGONIUMS

We have a fine lot of strong plants in 3 inch pots of Purity, Countess of Crew, Duke of Cornwall, Galatea, Gloriosa, Lady Carrington, Tommy Dodd and others at \$1.50 per doz., \$6.00 per 100.

GERANIUMS

Our new illustrated catalogue mailed to the trade. We have a fine lot of standard varieties and novelties from \$2.00 per 100 up, good stock from 2 inch pots. We will send 1000, 50 each of 20 good sorts for \$18.50; 500 for \$9.25. Cash with order. Not less than 500 sent at this price.

R. VINCENT Jr. & SONS COMPANY
White Marsh, Md.

NEW A MONEY MAKER NEW CARTER'S DOUBLE BLUE LOBELIA

\$2.50 per doz., \$18.00 per 100

CASH WITH ORDER PLEASE. J. FULLER, 31 Orchard St., LEOMINSTER, MASS.

CANNAS

Send for our List and Prices

The CONARD & JONES CO.
WEST GROVE, PA.

NEPHROLEPIS SCOTTII

in the following sizes, extra good value
25c., 50c., 75c., and \$1
Grand Specimen Plants at \$3, \$4, \$5, \$6.

JOHN SCOTT
R Highland Road and E. 45th St.
Tel. 3-30 Bedford BROOKLYN, N. Y.

AZALEAS FOR FALL DELIVERY

The best that are grown, also
Palms for Spring or Fall delivery furnished by AUGUST HAERENS, Somergem, Belgium. Orders booked now. Address the American representatives.

AUGUST ROLKER & SONS, New York
31 Barclay Street, or P. O. Box 752

GODFREY ASCHMANN

Importer and Wholesale Grower and Shipper

of Araucaria Excelsa, Compacta, Robusta and Glauca; Keotia Forsteriana and Belmoreana Azalea, Indica, etc. Cultivator of Boston, Scottii, Barroweni, Elegantisima and Whitmani Ferns. Ferns for dishes, Cocos, etc. Write for prices.

1012 Ontario St., Philadelphia

Just Received in Splendid Condition

15,000 AZALEAS

in all sizes and varieties

25c. up to \$2.00 each

Also Kentias, Rubbers, Araucarias, Pandanus, Boxwood, Euonymus, Crotons, Areca and Eurya latifolia.

Extra good value in large
Specimen and Decorative Palms
A. LEUTHY & CO.

Perkins Street Nurseries, Roslindale, Mass.

NEP. WHITMANI

2 1/4 in., \$5.00 per 100

NEP. WHITMANI

3 1/2 in., \$25.00 per 100

BOSTON FERNS

2 1/4 in., \$3.00 per 100

H. H. BARROWS & SON Whitman, Mass.

FERNS

Boston, 4 inch 12c, 5 inch 25c.

Pteronii, 3 inch 5c.

Elegantissima, 2 1/4 inch 6c, 3 inch 10c, 4 inch, 15c.

BAUR FLORAL CO., Erie, Pa.

Rooted Carnation Cuttings

Pink	100	1000
Aristocrat	\$6.00	\$50.00
Winsor	6.00	50.00
Rose Pink Enchantress	3.50	30.00
Enchantress	3.00	25.00
Lawson	2.50	20.00
Joost	2.00	15.00

White

White Perfection	3.00	25.00
" Lawson	3.00	25.00
Queen	2.00	18.00
Boston Market	2.00	18.00
Louise	2.00	18.00
Lt. Peary	3.00	25.00
Bountiful	2.50	20.00

Red

Beacon	6.00	50.00
Victory	3.00	25.00
Robert Craig	3.00	25.00
Flamingo	2.50	20.00

Miscellaneous

Patten	2.50	20.00
Harry Fenn	2.50	20.00
Harlowarden	2.50	20.00

Stock Guaranteed—Prompt Deliveries

THE LEO NIESSEN CO.

WHOLESALE FLURISTS

1209 Arch St., PHILADELPHIA

ROOTED CARNATION CUTTINGS

Only the Best Varieties

CHICAGO CARNATION CO., JOLIET ILL.

New Violet BOSTON

In introducing this new variety to the trade I wish to state that I have been growing it in quantity for the past two years and do not hesitate to state that it is entirely distinct, a strong grower, a free bloomer, and the finest single violet in cultivation. Ready for distribution in April and May. Orders booked now. \$2 per 100; \$12 per 1000; \$100 per 10000. 500 at 1000 rate.

WILLIAM SIM, CLIFTONDALE, MASS

ROBERT CRAIG CO.

ROSES, PALMS,

and Novelties in Decorative Plants

MARKET and 49th STREETS., PHILADELPHIA, PA.

100,000 DAHLIAS

Premium Stock, guaranteed true to name. 500,000 large Flowering Gladioli, hundreds of colors and variations mixed. Wholesale prices on application. Order now for spring delivery. Catalogue free.

J. L. MOORE, Northboro, Mass.

DAHLIAS.

Now is the time to place your order for bulbs which will insure you getting named varieties in any quantity; prompt delivery.

DAVID HERBERT & SON,

Successors to L. K. Peacock, Inc.

ATCO, N.J.

Winsor and White Enchantress

**Strong Rooted Cuttings
Now Ready for Delivery**

WINSOR has proved to be the finest carnation in the light pink class. We sold a large quantity of it last year, but there will be a much larger sale for it this year. At the English Carnation Show held in December, it was the winner in the light pink class. It is doing well everywhere and will supplant everything in that color.

WHITE ENCHANTRESS will occupy the same position among white carnations that Enchantress does among flesh pinks. It has all the good qualities of the common Enchantress,—long stem, earliness, large size, freedom, etc. In our opinion, it is by far the best white carnation ever introduced.

We have a splendid stock of both Winsor and White Enchantress ready for immediate delivery, and will guarantee perfect satisfaction with the cuttings supplied. Do not wait, because the demand for these varieties is bound to be enormous. **Order early, while we can promise immediate delivery,** and secure gilt-edged stock. We have a large stock of both of these varieties, and all our cuttings are heel cuttings, taken from flowering stems. On account of the quantity that we are growing, we are not obliged to over-propagate, and our stock is in the most perfect and healthy condition.

Strong rooted cuttings from sand, \$6 per 100, \$50 per 1000. Extra strong transplanted cuttings from soil, \$7.50 per 100, \$60 per 1000. Strong established pot-grown plants \$9 per 100, \$75 per 1000.

F. R. PIERSON CO.

Tarrytown - on - Hudson, . . . NEW YORK

CARNATIONS

NOW READY

Afterglow, the finest pink, and Britannia, the English scarlet, \$12.00 per 100.
Aristocrat, Winsor, Imperial, Beacon and Pink Imperial, all at \$6 per 100, \$50 per 1000.
White Perfection, Rob't Craig, Victory, Lady Bountiful, Mrs. M. A. Patten and Enchantress, \$3 per 100, \$25 per 1000.
Queen, Variegated Lawson, Fair Maid, Peary and Mrs. Lawson, \$2.50 per 100, \$20.00 per 1000.

Booking orders for GRAFTED ROSE STOCK of all standard varieties.

CHARLES H. TOTTY

Send for complete list. MADISON, N. J.

CARNATIONS ROOTED CUTTINGS

Winona, color, true clear pink, comes nearest to Fiancee but a different type flower. Growth on order of Scott but vastly improved in every respect. Early flowers in quantity and on long stems. Does not burst its calyx. Fine, shapely, active growth. In color and productiveness it is without an equal. Orders booked now and filled in strict rotation. \$12 per 100, \$100 per 1000.
White Perfection, pure white. We have a large stock. \$3 per 100, \$25 per 1000.

F. DORNER & SONS CO.

LA FAYETTE, IND.

CARNATIONS

WHITE ENCHANTRESS R. C.

This stock originated with and grown by me is the very best.

\$6.00 per 100, \$50.00 per 1000.

	Per 100	Per 1000
Enchantress, light pink,.....	\$2.50	\$20.00
Lawson,.....	2.00	15.00
Lord, light pink,.....	2.00	15.00
Queen, white,.....	2.00	15.00
The Belle, white,.....	2.50	20.00

250 at 1000 rate. Orders of 1000 or more will be shipped prepaid on receipt of check.

Get your R. C. early and have blooms when others have none.

FRANK H. KIMBERLY

631 Townsend Avenue, NEW HAVEN, CONN

ANNOUNCEMENT

Our new seedling carnation, **OREADOR**, will not be disseminated until January 1909.

For further particulars address, **The H. WEBER & SONS CO., Oakland, Md.**

LLOYD

IS THE REAL THING
The Carnation for every one to grow

LLOYD is a commercial white, with a fancy flower

The only ever-blooming, large-flowering white in existence Will take the place of all other whites now in commerce. Every New Bedford grower has bought stock. Come and investigate.

**A KEEPER
A SHIPPER
A BLOOMER**

It will bring the shekels when all others fail

\$2 pr 12. \$12 pr 100. \$100 pr 1000

Unrooted Cuttings
\$6 per 100. \$50 per 1000.

H. A. JAHN

NEW BEDFORD, - - MASS.

Winsor Carnations.

From 6000 plants we have plenty of exceptionally fine stock, and 50,000 ready for shipment now. From 2 1/2 inch pots, \$7.00 per 100, \$60.00 per 1000. Rooted Cuttings, \$6.00 per 100, \$50.00 per 1000

A. N. PIERSON, - - Cromwell, Conn.

JOHN E. HAINES

Bethlehem, Pa.

is the place to order rooted-cuttings of the following varieties for 1908.

John E. Haines, red	} Per 100 Per 1000
Imperial variegated	
Pink Imperial, Pink	
Enchantress, Light Pink	
Place your orders early for Jan. delivery.	\$6.00 \$50.00

Carnation Cuttings

Both standard varieties and novelties. Stock guaranteed to be first-class. Address,

S. S. SKIDELSKY

1741 North 18th Street, Philadelphia

NEW My Maryland ROSE

Best up-to-date commercial rose; read what others have to say about it.

Among the many new roses of the year there is none which has impressed us more as being worthy of a thorough trial. It has been exhibited only as 294, being a seedling raised by John Cook of Baltimore. A beautiful rose with an exquisite fragrance; in color it may be described as a soft salmon pink which brightens up beautifully as the bud opens. We are intending to plant this rose in quantity.

A. N. PIERSON, Cromwell, Conn.

In reply to your inquiry what we think of your new rose, My Maryland, we would say that after seeing others we still believe that you have the best new rose of modern times.

GUDE BROS., Washington, D. C.

Price 2 and 2½ inch pots, \$25 per 100; \$200 per 1000. Price 3 inch pots, \$5 per dozen.

JOHN COOK, 318 North Baltimore, Md.
Charles St.

Hardy Roses

American Grown—Superior to Imported

We have unsold at the present time the following varieties—all field grown plants, grown in our nurseries at Rochester, N. Y.:

- | | |
|--------------------|-----------------------|
| Anne de Diesbach | Prince Camille |
| Clio | Frich Brunner |
| Fran Karl Druschki | Crimson Rambler |
| General Jacquemont | White Rambler |
| John Hopper | Yellow Rambler |
| Mme. G. Luizet | Philadelphia Rambler |
| Marshall P. Wilder | Common Sweet Briar |
| Mrs. John Lalng | Mme. G. Bruant |
| Paul Neyron | Wicharlana (The Type) |

These plants are in our storage cellars and can be shipped at any time. Prices on request.

ELLWANGER & BARRY

Nurserymen—Horticulturists

Mount Hope Nurseries, Rochester, N. Y.

Hardy Rhododendrons Azaleas Conifers, Clematis, H. P. Roses, Shrubs and Herbaceous Plants from our

HOLLAND NURSERIES

Prices Moderate

P. OUWERKERK, 286 Jane St., Weehawken Heights, N. J.

AMERICAN NURSERY COMPANY COMBINING

FRED W. KELSEY New York City
F. & F. NURSERIES Springfield N. J.
BLOODGOOD NURSERIES, Flushing, L. I.
N. J. & L. I. NURSERIES.

We Can Supply Your Every Need. Write for Prices
SALES DEPARTMENT, 150 Broadway, New York.

Established 40 Years

Rose Hill Nurseries

New and Rare Plants

NEW ROCHELLE, N. Y.

New York Office, Siebrecht Building, 425 Fifth Avenue

RHODODENDRONS, ANDROMEDAS, KALMIAS AND SPECIMEN EVERGREENS

JOHN WATERER & SONS, LD.

AMERICAN NURSERY

BAGSHOT, - - - ENGLAND

ROSES FOR FORCING Immeiate Delivery Strong-Dormant Send for Prices and List

American Beauty, Clothilde Soupert, Gloire de Dijon, Hermosa, Kaiserin A. Victoria, Killarney, Liberty, La France, Laman Cochet, Marechal Neill, Mrs. R. G. Scharman-Crawford, Marchioness of Londonderry, Souv. de la Matmaison, including all the leading varieties of Hybrid Perpetuals.

BAY STATE NURSERIES, No. Abington, Mass.

NEW ——— NEW
RAMBLER ROSE "NEWPORT FAIRY"
To be disseminated Spring, 1908. Ask for illustrated pamphlet and prices
JULIUS ROEHRS CO., Rutherford, N.J.

SPECIMEN EVERGREENS

Box Plants, Azaleas, Rhododendrons, Roses, Herbaceous Perennials
In fact everything in hardy stock for Garden, Lawn and Landscape Planting.
General Catalogue and Trade Lists on application.
The NEW ENGLAND NURSERIES, Inc., Bedford, Mass.

The Mechanical Fineness of Fertilizers The Fertilizing and Selecting of Cyclamens

For the many users of bone or slag we publish these remarks although these are not soluble fertilizers. What solubility they have, however, at the best is so dependent upon fine grinding that we wish to drive home the close connection between fine grinding and immediate value.

We are aware that some prejudice exists against fine bone as some maintain its greater liability to adulteration. This may have some truth in it. The way to spot this sort of thing is by the microscope and chemical analyses, which can not be carried about on the person, and even these are not entirely satisfactory. Now we hold no brief for the State Experiment Stations, in fact, we may sometimes differ with them, but this is what they are for, for one thing, and if a brand is rated well, year after year and comes from a reputable house these facts should have due weight.

Experiment Stations now grade bone and other fertilizers according to their fineness in addition to the usual chemical analyses. A column is marked "Mechanical Condition" and a screen of about 40-mesh is taken as a standard. What goes through is termed "fine," what does not, "coarse." The larger proportion of tests show more coarser than finer particles.

A word as to "mesh." By this we mean so many holes to the linear inch, the size thereof depending upon how much room the wire or fabric takes up. This has not been made standard as several scales are used even in this country, but for the smaller sizes as 40 and over, it is well enough to consider the wire as thick as the hole is wide so 40 mesh would mean a hole of one-eighth of an inch across.

It may not be practicable to grind to 200 mesh although this is not uncommon in other industries. One hundred can not be very difficult or expensive as shown by the fact that an importer of slag has told us that this runs about 100 mesh. This is a cheap source of phosphates.

This array of figures is to show at a glance the great increase of area with fineness which means just so much progress toward value extracted. This method of stating a truth may make a clearer appeal to the understanding than mere assertion or even eloquence (were we capable of this last.)

Size	Surface	Proportion
Sphere 1 in. in diameter	3. sq. inches	1
" 1-2 " " "	6. " "	2
" 20 mesh	125. " "	42
" 30 mesh	189. " "	63
" 50 mesh	314. " "	100
" 100 mesh	628. " "	200
" 150 mesh	952. " "	300
" 200 mesh	1256 " "	400

Notice that a substance averaging 20 mesh would have only a fifth the surface of one averaging 100 mesh.

The additional cost of fine grinding should not begin to be as expensive to the consumer as the good results obtained immediately.

Rudley M. Bray

In reply to Mr. Stuart's enquiry in last week's HORTICULTURE, regarding the cyclamens at Sandringham, and the methods of selection carried on there, I may state that the system followed is, I believe, exactly similar to that of any seed raising firm, only of course the operations at Sandringham are done on a very small scale.

No, Mr. Stuart, we did not do our fertilizing in a house of mixed colors, neither could one ever hope to improve, or even retain, the good qualities of a strain of cyclamen, by following such a course, as it is against all the laws of selection and is inconsistent with the object we have in view. The idea which should dominate us above all things, before we start our operations, is that we should first form an exact conception of the type of plant we are striving to produce, and then confine our efforts to "selected" plants which come nearest to this ideal.

We must of course keep each color separate. Few people outside the large trade growers could afford to devote a separate house for each color; neither did I think it necessary to do so, when I advocated private selection in my previous article.

At Sandringham, the greatest pains was taken each year when selecting the plants which were to be set aside for seed purposes. Care was taken to retain for this purpose only the finest plants of each particular color. Each color was kept entirely by itself, a scheme of isolation being carried out, and as there were plenty of houses suitable for our purpose, each color was given a corner of a house to itself. Before starting our operations, we carefully noted the result of the previous year's work, and were thus in a position to see whether our past efforts along different lines had been successful. If one sort showed signs of losing color, we at once took steps to remedy it. If, on the other hand, we required more vigor, and new blood might give us our desire, then we scoured the country until we found the exact type of plant which would be suitable for the purpose.

In fertilizing each plant we always had a definite object in view, and a record was made of every stage of the work. This was kept, and compared every year; it showed us the results of certain crosses which had been made in previous years and, also, gave an idea as to the amount of progress being made, and I can assure Mr. Stuart that we always advanced, especially in the quality of the flowers, and in richness and coloring.

Mr. Stuart remarked that with him poor results came from selection of seed from good flowers, the size of the flower, foliage and stem being retained "and improved" but not so the color. He ought to have informed us whether any steps were taken to remedy this fault. It appears, however, that Mr. Stuart could not have been very persevering in his efforts, or he would have gained at least some small measure of success. Our experience has been that improvement in color can only be attained by the union of colors, bearing in mind of course the natural law, which says that we must unite two to make one. The artist, for example, has always to mix certain colors to get the

particular one he desires and this same theory applies to the work of selection.

I admit that rapid degeneration is common with cyclamens, unless careful selection is maintained each year. Experience has satisfied us, however, that by patience and perseverance we can gradually, year after year, fix and improve our strain, and produce seed for our own private use, superior in every respect to that sold by the average seedsman.

Mr. Stuart in his conclusions states that he is still of the opinion that good culture helps greatly in bringing out the rich qualities of a strain of cyclamen. Quite so; that goes without saying; but I think he will also admit that no amount of good cultivation could ever bring out any rich qualities from a bad strain. After all is said and done, it is selection which dominates the natural world, or in other words, it is the survival of the fittest.



North Easton, Mass.

The Hydrangea Question Settled

To the Editor of HORTICULTURE:

Mr. E. G. Hill has asked me in your issue of January 25 to determine the name of the handsome sterile form of *Hydrangea arborescens* named by him, *Hydrangea arborescens alba grandiflora*.

There are at least two forms of the North American *Hydrangea arborescens*: on the first the leaves are oblong-ovate and mostly acute at the base; on the second the leaves are broad and cordate at the base.

Of the first of these forms a variety *sterilis* was described by Torrey & Gray in their *Flora of North America* (i. 591) published in 1840. In this form which had been discovered at Wysox, Pennsylvania, the ray-flowers are not more than half an inch in diameter and the sepals are oval and round and furnished with a short point at the apex. This certainly is not the plant which has been cultivated and described by Mr. Hill, for his plant is a form of *Hydrangea arborescens* var. *cordata*, with neutral flowers an inch across and broadly ovate and acute sepals.

In the *Mitteilungen der Deutschen Dendrologischen Gesellschaft* for 1907 (p. 71) Mr. Alfred Rehder has proposed the name of *Hydrangea arborescens* f. *grandiflora, forma nova*, for Mr. Hill's plant and this is the name by which it should be known. As Mr. Hill, in using two varietal names for the same plant, did not follow the recognized rules of botanical nomenclature, Mr. Rehder who next described the plant, being at liberty to select either of the two varietal names previously applied to it, very properly took *grandiflora* as being the more descriptive of the two.

It is interesting to note that in the Gray Herbarium there is a specimen of *Hydrangea arborescens grandiflora* collected at Nashville, Tennessee, without date or name of collector.



Arnold Arboretum, Boston.

The Perennial Border as a Recreation

When once a move is taken to improve the home grounds with any kind of plant or plants, it is very hard to tell where to stop. The interest that this first planting arouses gradually leads to a recreation and often a decided hobby, and it is a hobby that is not only permanent, but is also an important factor in every estate, large and small. When once started, I feel confident in saying that additions and important changes will constantly be made year after year.

There are hobbies and hobbies; everybody has a hobby or should have; but the greatest and best of all is one that brings us as near to nature as possible, and the planting of a hardy perennial border is a recreation that it is hard to beat. The business man enjoys it morning and evening; the rest of the family all the time. It is a continuous pleasure from the middle of April till October, and during these six months there is not one day that the border looks exactly the same as the day preceding. For this reason, fresh interest develops from day to day, as there is always something new and different to look forward to. And this interest is not confined to the flowers alone, but the foliage, fruit, and habit—all play an important part in the general pleasure derived.

As soon as the warm spring days come we begin to watch for old friends, hepaticas and anemones first greeting us. Anemone pulsatilla (pasque flower) is one of the handsomest of spring flowers, with its beautiful silky sepals and large violet flowers. The seed-head is also very pretty reminding one of clematis, and the foliage is ornamental till autumn.

I have no intention of mentioning every perennial grown, but only some of those that are not as generally known or used, and also a few of the best older kinds that should be in every border. Primroses and polyanthus soon follow the hepaticas and always do well. Mertensia virginica is very early, having light blue tubular flowers in clusters, on stems long enough for cutting. Phlox divaricata var. Laphamii is, I think, going to take the place of the type, as it will stand our hot summers better. Trollius is one of the showiest and handsomest of spring flowers, but it is very confusing to dealers to have them called double buttercups (*Ranunculus acris plena*) instead of Globe flower which is a more appropriate name, and describes the flower very well. The double pink variety of Lychnis Flos-cuculi is excellent for cutting purposes, and will continue to bloom as long as the ground is moist.

June ushers in peonies, German iris, and lilies of some varieties. The new Anemone Italica var. Dropmore is a fine border plant, but is useless for cutting. The flowers are of good size, deep blue, borne on large compound spikes. The dianthus or hardy garden pinks are as popular as any perennial and are general favorites with everyone. That charming variety, Na-

poleon III, most certainly takes the lead and should have special mention. The double form of *Spiraea filipendula* is not planted enough; it always looks well, with its fern-like foliage and graceful cream white flowers; is good for cutting, although the petals drop somewhat.

Delphiniums and aconitums of the *napellus* section are July favorites; not to forget Japanese iris, hollyhocks, sweet williams, lupins and gaillardias. *Tritoma* has graceful foliage and distinctive flower heads. The double *Babies' breath* is becoming as popular as the single form. *Clematis mongolica* is a decided improvement on *C. recta*, *Chrysanthemum maximum* "King Edward" has flowers from three to four inches in diameter and is a continual bloomer from July till frost. *Phlox decussata* starts blooming the latter half of July but the full beauty is not seen till August.

Aster amellus elegans, *rudbeckias*, *helianthus*, *stokesia* and *veronicas*, now take their turn in helping to make the garden beautiful. *Cephalaria* is not very generally known, but is very handsome with its tall branching spikes of lemon yellow flowers, similar in shape to an annual *scabiosa*. *Helium autumnalis superbum* is a very handsome plant, growing about six feet high, with flowers of a showy terra-cotta red.

Asters help to make September glorious. *Aconitum autumnale*, and *A. Fisheri*, Japanese anemones, *Pyrethrum uliginosum* and late blooming sunflowers, all do their part.

Eulalias make a fine show in October and with the hardy *chrysanthemums* end the season. And all this interesting succession of flowers will be renewed year after year; old friends will be recognized and new ones added.

Frederic J. Rea.

The Ideal Horticulturist

It is noteworthy that the practise of Horticulture tends to develop a similarity of character. Local conditions give a slight variation, yet the general lineaments bear unmistakable marks of resemblance to a certain type found the world over, which is clearly seen to be the product of a cultivated environment. A good deal is written on the utilization and arrangement of Nature's material; too little is noted of that silent moulding influence she radiates upon her devotees.

Man is ever larger than his greatest work. In the production of landscape and floral art both cause and effect are within himself; he is the responsive chord which vibrates the music of Nature's melody back to his soul; he thus gives a voice to the mute creation. It is this power of gentle ministry to the sense of beauty in man, which is the basal argument for our business; if our products are not beautiful they cease to be useful; in the last analysis, it rests not upon utilitarian but upon aesthetic foundations. It is inevitable that the struggle for existence brings out the commercial as-

pect; we lose much, however, if we entirely ignore the poetry and beauty of the things we daily handle.

To the trained eye every plant is a symbol and reflects an idea. The power to extract the spiritual essence, to see the plant soul beneath the appearance, to identify and seize the substantial or evanescent image, may serve as subtle compensations in a none too profitable business.

Then, too, Nature challenges thought and gives to the mind that gentle impulse and exercise so helpful to a wise and calm outlook on life. This habit of inductive reasoning, from the simple to the complex, the correlation of observed facts, tend naturally to make plant lovers either moralists or philosophers.

"Flower in the crannied wall, I pluck thee out of the crannies,
Could I know thee root and all I should know what God and man is."

To get the most out of Nature one needs the blending of the scientific with the aesthetic spirit; the arid tablelands of thought need and gain enrichment by the soft warm drapery of color.

The analytic spirit searches outward. We feel beauty by the photographic method of exposure; what is recorded also will depend on the sensitiveness of the plate; a certain receptivity of mood is needed which cannot in the rush of life be always commanded, for at different times the same object does not make an equal appeal.

There are two methods of approach to Nature's treasure trove, namely the microscopic and the telescopic. In the former concentration is needed to exclude for a time the general view in order to explore "the small proportions in which we just beauty see." The telescopic seeks a definite impression of the whole line of vision. To adjust one's mental lens easily to both methods is a mark of the ideal horticulturist, the reward of practical experience.

The aim of the worker should be to secure insight into and a broad outlook over all departments; at the same time making himself a specialist in at least one or two branches. An apprentice needs a little wise direction with a view to the effect upon his future character. It is a mistake to start a boy inside; give him a chance to build up a sound constitution outside, then, taking his education under glass later, he will come to a full-orbed experience with energy and power to turn it to practical account. There is a species of exotic tenderness about men who have worked solely amongst orchids and high-colored foliage plants, which shows itself in a fastidious contempt for other branches. Possibly a change outside for a time with rougher work might result in a more healthy outlook on every aspect of the great field. Many enter the business lured by the love of the beautiful only to find there is another side, rough and dirty, though not necessarily sordid. One cannot secure Nature's best without sweat of hand and brain. Eternal vigilance is the price paid by every successful plantsman. Necessity is a stern taskmaker, it is true, but glimpses by the way of a world made beautiful should lighten the toil and the exacting nature of the work should serve to give zest to the pleasure of producing, as clouds give a brighter relief to the rainbow. If a man is made of the right material the business will evoke his best; the ideal horticulturist has gained by the nature of his tasks, he has grown in "sweetness and moral height."

Edgar Elwin

HORTICULTURE

VOL. VII FEBRUARY 15, 1908 NO. 7

PUBLISHED WEEKLY BY
HORTICULTURE PUBLISHING CO.
 11 Hamilton Place, Boston, Mass.

Telephone, Oxford 292

WM. J. STEWART, Editor and Manager

SUBSCRIPTION PRICE

One Year, in advance, \$1.00; To Foreign Countries, 2.00; To Canada, \$1.50

ADVERTISING RATES

Per Inch, 30 inches to page \$1.00.

Discounts on Contracts for consecutive insertions, as follows.

One month (4 times) 5 per cent., three months (13 times) 10 per cent.,

six months (26 times) 20 per cent., one year (52 times) 30 per cent.

Page and half page spaces, special rates on application.

Entered as second-class matter December 8, 1904, at the Post Office at Boston, Mass. under the Act of Congress of March 3, 1879.

CONTENTS

	Page
FRONTISPIECE— <i>Primula acaulis</i> .	
THE MECHANICAL FINENESS OF FERTILIZERS	
—Dudley M. Pray.....	197
FERTILIZING AND SELECTING OF CYCLAMEN	
—Wm. McM. Brown.....	197
THE HYDRANGEA QUESTION SETTLED—Prof.	
C. S. Sargent.....	198
THE PERENNIAL BORDER AS A RECREATION	
—Frederic J. Rea.....	198
THE IDEAL HORTICULTURIST—Edgar Elvin....	199
AFTER ADJOURNMENT.....	201
PRIMULA ACAULIS.....	201
LIBRARY NOTES—C. Harman Payne.....	201
NEWS OF THE CLUBS AND SOCIETIES:	
New Jersey Floricultural Society—Gardeners'	
and Florists' Club of Boston—Pittsburg Flor-	
ists' and Gardeners' Club—Nassau County Horti-	
cultural Society—New Bedford Horticultural	
Society.....	202
New York Florists' Club—Chicago Florists'	
Club—Toledo Florists' Club—Florists' Club of	
Washington—Newport Horticultural Society—	
Huntington Horticultural and Gardeners' Soci-	
ety.....	203
Washington State Horticultural Association—	
Society of American Florists—Pasadena Gar-	
deners' Association.....	208
Club and Society Notes.....	209
American Rose Society.....	220
EXPERIMENTS IN CARNATION GROWING—Dr.	
B. T. Galloway—Illustrated.....	204
SEED TRADE.....	206
INDOOR CULTURE OF CARNATIONS—E. A.	
Harvey.....	210
FLOWER MARKET REPORTS:	
Boston, Buffalo, Chicago, Indianapolis, New	
York, Philadelphia.....	213
OBITUARY—J. B. Heiss, Portrait—Wm. J. Allan—	
N. R. Cook—Other Deaths.....	221
MISCELLANEOUS:	
Catalogues Received.....	206
Plant Imports.....	207
Personal.....	209
Philadelphia Notes.....	213
News Notes.....	220-221
Fire Record; Incorporated; Business Changes.....	213
Greenhouses Building; List of Patents.....	222

The passing of
 "sterilis"

All parties who now wish to persist in cataloguing "sterilis" will undoubtedly be given free scope in their endeavors, whilst their allies, the "hindsight" critics, ponder on the dangers of a little learning and the mononymous scribbler silently steals away.

A proposed
 rose bulletin
 Rose Journal.

Our congratulations to E. G. Hill on the outcome of the Hydrangea controversy. Also to the S. A. F. registration department in its vindication.

The American Rose Society, through its energetic secretary Benjamin Hammond, announces its purpose to issue a quarterly publication to be called The

Enterprise. This is in accord with views expressed by several active members of the Society at the annual meeting in Washington last year. We can see no reason why it should not, with good management, succeed. The membership of the Society is small, so far, but the country boasts many thousands of devotees of the rose — and their number is rapidly increasing—who, if they can be reached and rounded up, will be glad to support a publication giving acceptable and timely news about the queen of flowers and will thus furnish a basis for the support of advertisers without whose support the project could not be made self-sustaining. We shall be glad to see the plan successfully put in operation. The influence of such publications is always on the right side for the advancement of horticulture and the benefit of the horticulturist. We congratulate the executive committee of the Rose Society on their courage and extend our heartiest good wishes for the success of the enterprise.

Our attention has been called from time to time during the present season, to occasional articles in the daily papers from various places, in which the violet is spoken of as no longer fashionable or popular. It is unfortunate for the violet that at a time when it is produced in perfection and in greater profusion than ever before it should be discredited in this manner. While it is not true of all yet it is true of a great many people that they are influenced largely by what they read in the daily papers and undoubtedly the sale of violets is affected to a greater or less extent by the articles referred to, the origin of which may often be traced to the unwise remark of some local florist, made to gain some momentary object without thought of the widespread injury inflicted on the trade in general in which he himself must indirectly share. To advance the interests of the rose, carnation, orchid, violet or other flower in the sale of which one may be specially concerned it is not necessary to disparage the others. If any flower is doomed to lose caste with the public let it not be said that the florist trade bears any of the responsibility.

For many years those growers who by reason of soil or other local advantages found themselves able to produce violets of a superior quality were in a position to dictate market prices and they did it, as anybody else would have done under the same circumstances. The enormous increase in production which followed, year after year, was the natural result. It was also natural and inevitable that the limit would be reached some time and it took no great prescience to see that in the order of things the day would come when in the great flower communities the exclusive special violet would make its appearance on the curbstone stand and to realize that, thenceforth, price control would shift from grower to consumer and that old conditions could never be brought back. How much of the reported indifference or actual antipathy to the violet in certain fashionable circles is due to the abundance and consequent commonness of the flower we shall not attempt to say but unquestionably this factor must be taken into account. Further, the well-known practices of the curbstone peddlers in doctoring up stale stock with perfumery is an offense which must react to the detriment of the violet industry. The truth is that the violet has been overburdened and abused. As to its future—well, only the growers know whether it is still a profitable proposition on the basis of this season's returns.

AFTER ADJOURNMENT.

As spring approaches let us plan, each and every one, to seasonably encourage popular horticulture—the most elevating recreation that can be carried to the threshold of every home. This sentiment faithfully put in practice would treble the plant, flower and seed trade the first season.

Horticulture is a practical pursuit requiring industry and care rather than scientific learning, yet he who assimilates and digests as much as possible of the fare that science continually places before him, in so far as it has a bearing on his work, will find it all helpful in directing the exercise of his industry and care upon right lines.

Our Philadelphia correspondent in his usual airy manner comments upon the rumors of petty graft in the private use of public plants in Boston and Washington and naively adds—“No such graft has ever been heard of in the Quaker City.” That “heard of” is used with wisdom aforesaid. Is it possible that the Quaker City is slow of hearing?

Summer school gardens, which have been conducted by the Philadelphia Board of Education for several years, will be curtailed this year because of lack of money. This was determined yesterday by the Committee on Special Schools. The action may foreshadow the dropping of the garden system altogether.

According to the report of William Stecher, director of physical training, there are 59 playgrounds, and the attendance during the year just past was 797,545 children. The average cost of maintenance was 3.8 cents per child a day of 7 hours.

At the summer gardens, of which there are 10, the total attendance was 91,000. They were open only 5 1-2 hours a day and cost 12 1-7 cents a child each day to maintain.

“I am inclined to question very much the wisdom of maintaining the gardens at all,” Professor Stecher said. “The attendance is comparatively small and the expense is heavy.”

The above information comes from the Philadelphia Ledger. Physical culture professors' advice is good only to a limit. Philadelphia, we hope, will look to a different source for intelligent advice concerning the intellectual and aesthetic welfare of her little ones. There are times when 12 1-2 cents' worth of healthy brain is a better bargain than 3.8 cents' worth of muscle and agility.

PRIMULA ACAULIS.

The garden forms of *Primula acaulis*, or *vulgaris*, are numerous, but none are more beloved than the pale lemon-colored original type with its deliciously fragrant blossoms borne singly on slender pedicels and welcomed throughout Europe and especially in England and Ireland as the sweetest herald of spring. It is fairly hardy in the latitude of Boston; it thrives all right in a sheltered location with a slight mulch of leaves or other material. It is easily raised from seed and improved strains are abundant. As pot-plants for Easter sales these have become very popular in recent years, the New York market especially using enormous quantities of this as well as of the polyanthus types.

LIBRARY NOTES.

[Any of the books mentioned in Mr. Payne's reviews can be supplied at publishers' price from the office of Horticulture.]

In accordance with our usual custom of giving at certain intervals a few notes on recently published gardening books on this side of the Atlantic we have now once again the pleasure of drawing our American readers' attention to those that have appeared since the last contribution under the above heading. The post of honor must unquestionably be accorded to a very handsome art volume upon a subject that has already been liberally treated by author and publisher alike and is entitled *Italian Gardens*, after drawings by George S. Elgood, R. I., with notes by the artist. (Longmans, Green & Co., London and New York). This is a grand addition to an ever interesting subject of horticultural interest, and this newly published work has the advantage over most of the others of being illustrated entirely in colors, there being 52 plates from drawings by the author.

The contents contain interesting chapters on the various villas and gardens depicted by the brush of the artist; they are mainly descriptive, the historical not being enlarged upon to any great extent. Six main divisions form the entire scope of the book and these are Pompeii, Roman Villas, Villas at Frascati, Florentine Villas, other Tuscan Villas, Villas of Northern Italy. Price, \$10.00.

Gardening in Town and Suburb by Harry H. Thomas. (Longmans, Green & Co., London and New York). The author of this little handbook is already known to the readers of Horticulture, and is one of those writers of the younger generation who promise to occupy a foremost place in garden literature. There is a good deal of practical matter comprised in this handy little volume. There are useful chapters on roses, carnations, lilies, bulbs, annuals, climbers, shrubs, etc. The warm, and cool greenhouse, and window gardening also come in for a share of the author's attention. Price, 63 cents.

Villa Gardens by W. S. Rogers. (Greening & Co., London). Some few years ago the author of this treatise published a manual on the laying out of Villa Gardens and the book now issued appears to be a cheap reprint. The main idea of the author is the rectilinear system and he gives a number of plans with perspective views of some of his suggested designs. In our opinion the book fills a long felt want. Too often we notice in London suburban gardens an absolute lack of ingenuity in the laying of them out. Many of the owners affect a kind of wobbly winding path that suggests nothing artistic and rather causes one to ask if in the planning of the paths the designer was not suffering from shaking palsy. Price, 62 cents.

Pictorial Guide to Gardening by the editor of *Garden Life*. (Cable Printing and Publishing Co., London).

This is one of the many cheap issues of practical garden books that are being turned out by the many horticultural publishers here. It is a closely printed book of 250 pages in paper wrappers, dealing in practical language with almost every phase of the garden art. The work is illustrated with small line engravings in great profusion and is certainly one of the cheapest books ever published. Price, 25 cents.

Bulletin de la Societe Francaise d'horticulture de Londres. This is an annual publication issued by the French Gardeners' Society of London. In every way the society is flourishing and doing a useful work by the way in which it places young French gardeners in situations in England and young English gardeners in France. It is worthy of note that the society is entirely self supporting and receives no subsidy from the French Government, as some French societies abroad do. Free.

Flowers and Fruit for the Home by J. L. Richmond. (T. N. Foulis, Edinburgh and London). A series of practical papers on horticulture for amateurs and gardeners by the Garden Editor of the well known ladies' newspaper “The Queen.” It is well printed and contains a number of illustrations of flowers, etc., executed in photographic process blocks of fair average quality. Price, 80 cents.

The Book of the Chrysanthemum by Percy S. Follwell. (John Lane, London and New York). This is one of a series of practical garden books which has now reached its 29th volume. The author starts with an account of the history of the chrysanthemum which does not contain evidence of very much original research and has several inaccuracies which should be corrected in another edition. Then general culture follows with succeeding chapters on selecting the buds, housing the plants, insects, diseases, hybridizing, raising new kinds from sports. For the exhibitor some special chapters are reserved then follow bush and trained specimen plant culture, market and early varieties, for exhibition, etc. Price, 62 cents.

Rock and Alpine Gardening by H. Hemsley. (J. Cheal and Sons, 53 Victoria street, Westminster). This is a phase of gardening that is unquestionably attracting a great deal of attention latterly. Ordinary gardening books more or less contain chapters on the rock garden but there are several works of recent date that deal exclusively with the subject. Mr. Hemsley is a practical man in the art of rock garden making and his useful little volume will be an acceptable one to anybody intent upon laying out such a desirable addition to one's garden. Price, 87 cents.

C. HARMAN PAYNE.

A FRANK TESTIMONIAL.

My ad. with you has proved the most effective of any thus far.

CHAS. A. KIBBE.

Elmhurst, Ill.

NEWS OF THE CLUBS AND SOCIETIES.

NEW JERSEY FLORICULTURAL SOCIETY.

An informal reception by the new president, Malcolm MacRorie, was given on the 7th inst. when members and friends gathered in force to wish him a successful administration. The society begins its fifteenth year with great promise. It is particularly strong in prominent private and commercial orchid growers, numbers all the leading gardeners and florists for fifty square miles around Orange, and has the support of the plant and seed trade and the good wishes of everybody.

Upon this occasion were present: Thomas J. Grey, of Boston; J. B. Kidd, seed appraiser for the port of New York; William Duckham, Arthur Herrington, Charles H. Totty, J. Austin Shaw, C. McTaggart, W. A. Manda, nearly all of whom addressed the gathering, and the Rickards' Bros., who dispensed sweet music. Most of these were in light and humorous vein. W. A. Manda spoke upon the forthcoming National Flower Show at Chicago, the advance sheets of the schedule of which he produced, calling attention to the fact that in it there was an inducement for all to contribute to one or more of its various classes.

The presentation of four silver cups won in the monthly competitive shows during the year was made to Peter Duff, William Reed, Max Schneider and Arthur T. Caparn with appropriate remarks by George Smith. Letters were read from H. Weber, John E. Haines, Chicago Carnation Co., and F. R. Pierson in connection with the special carnation night to take place in March and a characteristic letter of regret from W. J. Stewart, who is usually present at all these gatherings.

The floral decorations were contributed by members and consisted of carnations, flowering bulbs and a vase of *Euphorbia Jacquinæflora* with sprays two feet long, grown by Peter Duff, which Arthur Herrington declared he had not seen equalled since he was a boy in England. The evening was pleasantly interspersed with vocal and instrumental music and recitations, with light refreshment.

J. B. DAVIS.

GARDENERS' AND FLORISTS' CLUB OF BOSTON.

Owing to the halls of the Massachusetts Horticultural Society being rented for the entire week during which the regular club meeting was to have been held, a postponement of Carnation Night to Tuesday evening, February 25, has been found necessary.

W. R. Pierson, of Cromwell, Conn., will be the lecturer that evening, and in addition to our local members F. R. Pierson, Tarrytown-on-Hudson, N. Y., H. A. Jahn, New Bedford, and other carnationists from a distance will be present and take part in the discussion.

There will be numerous exhibits of novelties and the meeting should prove of deep interest. A record attendance is assured. A cordial invitation is extended to any who may not be club members to join us on this occasion.

W. N. CRAIG, Sec'y.

PITTSBURGH FLORISTS' AND GARDENERS' CLUB.

The meeting of the club February 1 was a Carnation Night, with a competitive exhibit by the home growers, divided in the two classes of commercial growers and private gardeners. J. Hutchinson read a provisional schedule for exhibits by private gardeners for prizes from June, '08, to and including May, '09. This schedule was laid over to the March meeting. The following officers were unanimously elected for 1908: F. Burki, president; E. C. Reineman, vice-president; H. L. Blind, treasurer; H. P. Joslin, secretary; E. C. Ludwig, assistant secretary; P. S. Randolph, Inc. Bader, C. S. Crall, executive committee. Ex-president Jones on retiring from office was warmly thanked for the two years of hard work he has given to the interests of the club. President Burki on taking the chair said that he could not make the club a success alone, but that he would do his part, and asked the members for their hearty support and aid.

The Pittsburgh delegation returned from the convention of the American Carnation Society in high spirits and full of enthusiasm. They feel that by withdrawing in favor of Indianapolis on the tie vote, they have silenced all opposition to Pittsburgh as the convention city in 1910, and the club is already talking of what they will do for the convention.

President Burki and Mr. Wyland called attention to the good work being done by the American Carnation Society, and solicited for it the hearty support of the members. Mr. Smith gave his experience with hydrocyanic gas, being much in favor of it. The secretary's report for 1907 showed a membership of 159.

Prizes were awarded as follows: Carnations, general display. Dark Pink. A. T. Lorch, 1st with Lawson; F. H. Westhoff, 2d with Aristocrat. Light Pink. Pittsburgh Rose & Carnation Co., 1st with Enchantress; J. L. Wyland, 2d with Enchantress. White. F. H. Westhoff, 1st; S. J. Hatch, 2d. Pink. Pittsburgh Rose & Carnation Co., 1st with Winsor; J. L. Wyland, 2d with Rose Pink Enchantress. Red. F. H. Westhoff, 1st with Robt. Craig; Finleyville Floral Co., 2d with Beacon. Private Gardeners. Thos. Jenkinson, 1st; N. C. Madsen, 2d. Cultural certificates to N. C. Madsen, gardener for *L. H. Boggs*, for *Primula obconica gigantea*; H. S. Price, gardener for G. B. Laughlin, for cyclamen; Jas. Hutchinson, gardener for Dr. Shafer, five varieties of odontoglossum which were grown in leaf soil covered with subaqueous moss. Certificate of merit to John E. Haines, for carnations Imperial, Pink Imperial and John E. Haines.

This is the first time that a competitive exhibition has been held by the club. The flowers were of a high order of excellence and much interest was shown.

H. P. JOSLIN, Sec'y.

NASSAU COUNTY HORTICULTURAL SOCIETY.

The third annual dinner of the Nassau County Horticultural Society, given at the Oriental Hotel, Glen Cove, Wednesday, Jan. 29, was a very enjoyable affair, about fifty members and guests being in attendance and partaking of the excellent spread. The tables were attractively laid and handsomely decorated with flowers and plants.

President Janeicke extended a cordial welcome to the assembly at five o'clock, and at the conclusion of the repast called upon J. Austin Shaw to act as toastmaster and that gentleman's pleasant opening address and his genial and tactful introduction of the several speakers gained him much commendation.

Alfred J. and W. C. Rickards, Jr., the latter presiding at the piano, rendered popular songs and responded agreeably to recalls frequently, and other superlative factors of the festivities were Robert Angus with his violin, James Cant with the bagpipes and John White with a vocal solo.

President Janeicke made a stirring address setting forth the purposes of the society and its claims upon the support of the horticultural profession, expressing the hope that it might in the near future have a home of its own.

Ex-President A. Mackenzie also spoke interestingly of the Society's work. Charles Lenker responded to the toast "Harmony."

D. McFarlane, W. E. Marshall, V. Cleres and A. V. Kohler made interesting addresses. James Scott gave some of his experiences as a "Drummer." W. Sperling spoke of "The Gardener as I have Found Him." J. Manda responded very happily to the toast, "The Ladies," and B. G. Davis spoke for "The Local Press."

President Janeicke then arose and spoke in commendation of the services to the society of Alexander Mackenzie in the offices of secretary and president and as a testimonial of appreciation thereof, on behalf of fellow members, presented him with a handsome fountain pen. It was a complete surprise to the recipient, and he expressed his thanks reciprocating the good feeling entertained toward him.

S. J. Trepess, chairman of the committee of arrangements, responded to compliments paid it for the admirable manner in which it had performed its duties.

The festivities closed with "Auld Lang Syne."

NEW BEDFORD HORTICULTURAL SOCIETY.

The question box furnished the means for an interesting evening at the February meeting of the N. B. H. S. on Monday. H. A. Jahn was awarded the silver medal of the society for a vase of fifty blooms of his new white carnation Lloyd. The schedule for the fall show was passed and ordered to be printed. The two New Bedford dahlias, Newport and Ruth Forbes, are to be placed in the market this year.

THOS. WHITE.

NEW YORK FLORISTS' CLUB.

The February meeting of this club, on Monday, 10th inst., was attended by about 75 members. Committee reports on several interesting subjects were made. The first was by P. O'Mara on the question of how best to co-operate with the Horticultural Society of New York for the advancement of horticulture, by means of exhibitions, etc. The views of the committee, as presented, were that a merger would be unwise but that the members of the club should individually become members of the Horticultural Society and thus contribute by their influence and support to the activities of the Society. After discussion pro and con the report was adopted and the committee continued. The dinner committee, through its chairman, W. F. Sheridan, made a seductive forecast of the festivities planned for the annual feast on February 29 at the Hotel St. Denis.

The national flower show to be held in Chicago next November was an interesting topic. W. A. Manda urged an enterprising policy on this matter, including the contributing of medals and trophies in the name of the club. Mr. O'Mara suggested the offering of a club sweepstakes prize of \$100. Messrs. Tetty, O'Mara and Manda were constituted a committee to consider and report. At a later hour this committee reported recommending that the club appropriate the sum of \$100 for a silver trophy to be offered for three specimen palms, distinct species, not less than ten feet in height, and under temporary suspension of the rules the proposition was voted affirmatively and the secretary empowered to telegraph Secretary Rudd of the S. A. F. accordingly. John T. Withers then read a carefully prepared and instructive paper, his subject being "The Value of the Shade Tree and Its Care." The paper was given a spirited discussion. The judges on exhibits, Jos. A. Manda, chairman, reported as follows: Violet Princess of Wales, from F. G. Mense, Glen Cove, N. Y.; Cultural Certificate. New Violet Boston, from Wm. Sim, Cliftondale, Mass.; Certificate of Merit. White Carnation Lloyd, from A. H. Jahn, New Bedford, Mass., arrived in bad condition. Crimson Carnation Wa-No-Ka, from Wa-No-Ka Greenhouses, Barneveld, N. Y., 85 points and a certificate. Pink Seedling Chrysanthemum from W. E. Hamilton, Belfast, Me., shown by C. H. Tetty. Thanks of the Club. Pink Seedling Carnation from W. A. Manda. 75 1-2 points. Resolutions of condolence with the families of the late Victor Dorval and Mrs. A. M. Henshaw were passed by unanimous votes.

CHICAGO FLORISTS' CLUB.

The Chicago Florists' Club have secured the Art Institute Hall for the American Rose Society convention to be held here on March 25 to 27. This is an ideal place, being centrally located and, with the Museum of Fine Arts in connection, they certainly could not have got a better spot. A goodly support is expected from the East on exhibits as the premiums will warrant their sending to this show. Any information regarding this coming event can be had of the Chicago

Club Secretary, T. E. Waters, 21 East Randolph street.

TOLEDO FLORISTS IN TIFFIN AND FOSTORIA.

Instead of meeting at the club room hereafter it is proposed that this club meet at the establishments of the different members. The first outing accordingly was on Tuesday, February 9th when a visit was made to Tiffin and Fostoria. The Ullrich place at Tiffin now run by the three sons of the late Lewis Ullrich, has about 75,000 feet of glass, consisting of a number of small houses and a large one of latest pattern, about 40x250 feet. While the roses were off crop, they showed that they have been producing heavily, Bride, Bridesmaid, Perle, Golden Gate and Meteor being the principal. Carnations, especially Boston Market, White Perfection, Enchantress, and Mrs. T. W. Lawson, all looked well. There are very spacious cold storage houses for bulbs and cut flowers and if anybody wants to see a place where every tool and supply has its place and is in its place, he can certainly find it here. After an inspection of the city store, which was opened shortly before Christmas, the visitors were escorted to a hotel, where an elaborate dinner awaited and was gratefully enjoyed. The Fostoria Floral Co. (E. R. Sackett, prop.) was next visited. This plant has about 60,000 feet of glass and Mr. Sackett is getting ready to put up four more houses of respectable size. The material has been ordered and the intentions are to start within a few weeks and have the houses planted by June with roses. Specialties are roses and carnations and we doubt if better flowers are grown anywhere. As to carnations they show the finest Enchantress this season and the other varieties are equally good. Refreshments, of course, were served and we departed with regret.

There is no question of the great benefit of such visits. Buyers and sellers get closer together and good fellowship among all is the result.

J. L. SCHILLER.

FLORISTS' CLUB OF WASHINGTON.

The monthly meeting of this club, on February 4th, was of special importance, being the night for the nomination of officers for the ensuing year. President Bisset declined to succeed himself, though it was the expressed wish of the entire club that he should do so. The following were nominated: President, Z. D. Blackstone and F. H. Kramer; vice-president, John Robertson and Geo. Shaffer; secretary, Chas. McCauley; treasurer, Wm. F. Gude; directors, Chas. McCauley, W. H. Ernest and James L. Carbery. Judges, John Robertson and Chas. McCauley. The election will take place at the March meeting. The secretary read letters received from Mrs. Hauswirth and John Clarke, each expressing appreciation of letters of sympathy received by them during their recent affliction. Peter Bisset exhibited two vases of his new seedling roses, Rosalie, which scored 84 points and an unnamed pink seedling which scored 87 points.

NEWPORT HORTICULTURAL SOCIETY.

At the last meeting of the Newport Horticultural Society the executive committee presented a schedule of premiums for a Rose Show to be held in June. In making up the schedule the committee took into consideration the prevalent desire to have a large general exhibition in mid-summer for which considerable funds would be absolutely necessary. These considerations had the effect of inducing the committee to eliminate certain classes, believing that with such an elaborate show in prospect for a later date the classes they thought advisable to strike out of the schedule for the June show would be better represented and filled as well as tending to still further emphasize the importance of the larger general exhibition. The society fully approved all the recommendations of the committee and adopted the schedule as presented.

Alexander McLellan read a paper on plant nomenclature in which he laid particular stress on the desirability of a strict observance of the justly recognized names of plants and the importance to horticulture and horticulturists of an increased knowledge of plant names, both botanical and common. Plant registration received its due share of attention from Mr. MacLellan in his paper, being as he said of sufficient importance to be placed in charge of the Dept. of Agriculture. The charge now made by the Society of American Florists for the privilege of registering a plant Mr. MacLellan considered unjust because for one reason it was of discrimination, in so far that members of the society were exempt from such charges which in his opinion was not what might be expected from a national society. The paper was well received, and a vote of thanks was awarded to Mr. MacLellan.

Robert Cameron of Harvard Botanic Garden will be the essayist at the next meeting, Feb. 25. Mr. Cameron in his paper will discuss Annuals and Biennials.

HUNTINGTON HORTICULTURAL AND AGRICULTURAL SOCIETY.

An interesting State Farmers' Institute was held on February 3 under the auspices of the H. and A. Society. Good speakers were present and there was a gratifying attendance. Up-to-date methods were discussed and helpful hints given on many agricultural topics.

The annual carnation exhibition of the society will be held on February 25 in the Trade School Building. There are classes provided for carnations, 25 in each class, violets, mignonette, freestias, spring bulbous flowers, greenhouse vegetables, etc. Competition will be for certificates. Schedule will be sent on application to A. H. Funnell, secretary, Huntington, N. Y.

EXPERIMENTS IN CARNATION GROWING BY THE U. S. DEPARTMENT OF AGRICULTURE.

Read before the American Carnation Society

Dr. Beverly T. Galloway, Chief of the Bureau of Plant Industry, in his address before the Society called attention to the experiments and tests of various kinds connected with the growing of carnations which have been carried on by the Department of Agriculture for several years. He stated that the work had for its object the securing of information on the following points:

1. The relative yield and vigor of plants grown under glass all summer as compared with plants of the same variety grown out of doors during the summer season and moved to the benches in the usual way and at the usual time.
2. Fertilizer tests to determine the value of different fertilizers alone and in various combinations on vigor and yield.
3. A study of hereditary tendencies in so far as same may affect continuous vigor and healthfulness and yield.
5. The securing of new and desirable types by crossing.
5. A study of fundamental questions of breeding with a view to securing data that will be of value to carnation growers and others in the improvement of their crops.
6. A study of diseases and means of preventing the same.

Dr. Galloway took up the subjects in the order given, using a table or chart large enough to be seen by all present, to illustrate the results of ex-



AGRICULTURAL DEPARTMENT, CARNATION HOUSES
Beacon at Left. Winsor at Right.

periments conducted during the summer of 1906 and the winter of 1907, to determine the relative yield of field and indoor grown plants. He explained how the experiment had been conducted, namely, that plants were propagated from stock of four varieties, care being taken to have the stock of as nearly equal vigor and productiveness as possible. Four benches in the greenhouse were given over to the work, each holding about

1000 plants and the same were planted with stock from 3-inch pots, two rows the entire length of each bench being reserved for the plants grown out of doors. Dr. Galloway stated that the field grown plants were given the usual treatment and produced fair average growth, but were not as large as those grown on the benches when brought in in September.

He stated that the results, as shown by the chart, were, without exception,

Complete fertilizer contains:
8% Nitrogen
12% Avail. Phos Acid
8% Potash

CARNATION EXPERIMENT

TABLE SHOWING NUMBER OF BLOOMS AND MARKET VALUE (NEW YORK PRICES),
FROM OCTOBER, 1906 TO MARCH, 1907.

BENCH AND VARIETY OF CARNATION	SOD SOIL COMPOST*				FLATS SOIL COMPOST*				- TOTALS -		BLOOMS & VALUES				
	A NO FERTILIZER	B UNSLAKED LIME	C STEAMED BONE	D LIME & BONE	E COMPLETE FERTILIZER	F LIME & COMPERT FERTILIZER	G NO FERTILIZER	H UNSLAKED LIME	I STEAMED BONE	J LIME & BONE	K COMPLETE FERTILIZER	L LIME & COMPERT	SOIL	FLAT	TOTAL
BENCH NO 1 ENCHANTRESS 77 PLANTS PER PLOT	846 BLOOMS 24.17 VALUE	855 24.52	698 19.43	767 21.57	785 22.14	762 21.62	728 20.63	688 17.96	774 21.01	698 18.80	719 20.00	795 20.66	4711 133.45	4385 719.86	9096 253.31
BENCH NO 2 LAWSON 88 PLANTS PER PLOT	782 BLOOMS 21.17 VALUE	739 20.74	810 22.20	772 21.46	814 22.08	663 21.46	688 22.08	711 18.89	688 19.24	694 19.60	722 19.82	678 20.56	4600 129.11	4181 120.28	8781 249.40
BENCH NO 3 PEARY 77 PLANTS PER PLOT	644 BLOOMS 17.98 VALUE	656 18.26	687 18.95	653 15.15	712 19.72	633 14.71	682 18.82	628 17.16	649 18.16	616 16.83	635 17.22	708 18.58	3685 104.68	3918 107.87	7603 212.55
BENCH NO 4 ROBY CRAIG 88 PLANTS PER PLOT	606 BLOOMS 17.21 VALUE	632 17.56	690 19.43	570 15.59	574 16.09	582 16.03	493 13.32	484 13.23	519 14.19	558 15.21	572 15.66	606 15.94	3654 101.91	3232 87.65	6886 189.46
											TOTAL BLOOMS		16350	15,716	32,066
											TOTAL VALUES		\$465.15	\$433.57	\$898.72

COMPARATIVE PRODUCTION: a PLANTS GROWN UNDER GLASS; b PLANTS GROWN IN FIELD ALL SUMMER.
FIGURES SHOW NUMBER OF BLOOMS PER 22 PLANTS DURING JAN., FEB., AND MARCH, 1907.

	a	b	a	b	a	b	a	b	a	b	a	b	a	b
ENCHANTRESS	175 86	192 84	138 58	165 100	167 97	163 93	162 67	144 67	179 81	148 79	155 82	163 70		
LAWSON	154 54	151 48	171 49	151 60	181 61	142 70	140 76	193 66	123 80	190 63	153 60	149 54		
PEARY	133 60	135 47	139 58	150 32	173 47	164 50	64 36	151 64	159 80	158 53	151 33	164 38		
ROBY CRAIG	138 51	152 48	164 50	129 63	133 60	138 51	122 42	122 38	128 39	139 31	135 50	147 40		

* NEW YORK PRICES PER 100 BLOOMS AS FOLLOWS: OCT. \$2.00; NOV. \$2.00; DEC. \$3.35; JAN. \$3.50; FEB. \$3.00; MARCH \$2.50.
* COMPOST - 3 PARTS SOIL AND 1 PART MANURE.

very much in favor of the indoor grown plants, in many cases the increase being over 100 per cent. He added, however, that while the results were so strikingly in favor of growing plants under glass the season through, from the standpoint of the Department, other considerations have to be kept in mind, such as the relative cost of the two methods, the production for an entire season, the utilization of the houses for other purposes, maintenance, etc., in determining which method to pursue.

The speaker also used the chart to illustrate his remarks upon the fertilizer experiments which the Department had carried on. He said that this experiment had been planned to bring out, if possible, the fact that growers as a rule are too prone to count on the value of commercial fertilizers in crop production, and he said he believed the results of the experiment would show that there is no fertilizer so good, reliable and sure as well decomposed organic manure—something which could be secured anywhere in the country. He said, however, that experiments of this kind to be conclusive, must be carried on for a number of years in various places. He cautioned the growers to go slow on commercial fertilizers and to put their faith and work into good composts.

He explained the work the Department had been doing in the study of hereditary tendencies in plants in so far as same may affect continuous vigor, healthfulness and yield. He said the question of whether there is true bud variation was still an open one, but that at the same time he did not think the importance and value of careful and rigid selection of stock could be questioned. This the Department has been doing and he stated it was its intention to continue this selective work for several years until the effects could be fully demonstrated.

The speaker mentioned the work the Department had been doing in the pro-



AGRICULTURAL DEPARTMENT, CARNATION HOUSES
Enchantress in Foreground, White Enchantress in Distance.

duction of new types by crossing and referred to some of the crosses that might be seen in the greenhouses.

He said that Prof. Norton, whose talk was to follow his, would explain in detail the fifth line of work, namely, a study of fundamental questions of breeding, which work he stated had been carried on by Prof. Norton before leaving the Department.

Dr. Galloway now took up the sixth line of work that the Department had been conducting, namely, an investigation of the diseases of carnations. Among the diseases studied was the wet stem rot, due to *Rhizoctonia*, which, he stated, continues to be one of the most serious diseases with which the growers have to contend, but that it could be controlled by growing the plants in well drained and well aerated soil contain-

ing plenty of lime, and by avoiding mechanical injury to the plants. He also mentioned the dry stem rot, a disease caused by *Fusarium*—one of the wilt fungi, and stated that the only remedy for this disease was to use sterilized soil and the liberal use of acid phosphate.

Two other diseases to which attention was called were the *Macrosporium* spot, which he said could be prevented by spraying with Bordeaux mixture, and the Bacterial spot, a disease occurring only in wet seasons on the softer-leaved varieties. This disease he stated might be controlled by light syringing with a mixture of two parts commercial formaldehyde to 1000 parts water.

Dr. Galloway closed his remarks by assuring the Society that the Department was always at their service and with an invitation to its members to visit the Department greenhouses.

HORTICULTURE'S REPRESENTATIVES.

The following named gentlemen represent this paper in their various local districts, and are authorized to accept subscriptions, advertisements and news items:

BUFFALO, N. Y.—E. C. Brucker, 385-87 Ellicott St.
CINCINNATI, OHIO—Frank W. Ball, 31 East 3rd St.
DETROIT, MICH.—Frank Danzer, 1487 15th St.
INDIANAPOLIS, IND.—George B. Wiegand 1610 N. Illinois St.
MONTREAL, P. Q.—Gabriel Vrengde, 27 Ontario Ave.
NEWPORT, R. I.—David McIntosh, Ledge Road.
MINNEAPOLIS, MINN.—C. N. Ruedinger, 2924 So. Aldrich Ave.
PHILADELPHIA, PA.—George C. Watson, Dobson Bldg., 9th and Market Sts.
PITTSBURGH, PA.—James Hutchinson, corner DuBois and S. Negley Aves.
TOLEDO, OHIO—J. L. Schiller, 929 Prouty Ave.

H. W. Koerner, Milwaukee, Wis., is building a new warehouse with cold storage cellar for storing dahlias. Concrete will be the material used in construction and when completed the building will be unique in its line.



AGRICULTURAL DEPARTMENT, CARNATION HOUSES
Seedlings of 1907 at Left; Helen Gould at Right.

Seed Trade

The Canners' Convention of 1908 has passed into history, and in all essential respects, excepting in the matter of the machinery exhibit, it will compare favorably with any of its predecessors. Owing to lack of floor space it was impossible to make the machinery part of the convention as large or attractive as last year, but this feature has become so large that it requires a hall of unusual dimensions to accommodate it.

The social part of these conventions, and in fact of all conventions, was a notable feature of the one just closed at Cincinnati. At the time of the Milwaukee convention in 1902 some ten or a dozen congenial spirits formed a little social organization known as the Ramblers, the object being to give a dinner to a chosen few of their friends. This organization has grown until at the recent convention the Ramblers and their guests numbered over 100. The entertainment usually consists of a dinner beginning rather late in the evening, followed by speeches by the leading Ramblers and their guests and winding up with a vaudeville performance, of more or less startling character. It is a decidedly Bohemian affair, yet withal quite elaborate, and invitations to the Ramblers' dinner are eagerly accepted by the most prominent members of the canning industry.

Contrary to custom, the place for the next convention was decided before the last one closed, the place chosen being Chicago. The windy city had some hustling representatives there who offered such attractive inducements that the canners were quite readily won over to their cause. One of the features of this next convention will be a Pure Food Show in connection with the machinery exhibit, and according to present plans the convention will be held at the Coliseum. The great size of this building with its several halls enables the committee having the matter in charge to conduct the Pure Food Show as a part of the exhibits without in any way interfering with the necessary space for the machinery and supplies association. By the way, this machinery and supplies association, which has heretofore been a rather loose-jointed affair, and which owing to its rapid growth has been becoming more unwieldy each year, has now been incorporated and hereafter will be controlled by a board of directors, its officers being a president, vice-president, secretary and treasurer. The constitution and by-laws adopted may be changed to suit conditions which will no doubt develop in the future, but it will be a much more compact and manageable organization than it has become of recent years.

As predicted in a recent issue of HORTICULTURE, the price of seed peas and seed corn, both had a sinking spell during the progress of the convention. This alludes only to spot goods, although in the scramble to secure business there was some drop in the price of futures. One fact was developed, however, to the satisfaction of everyone, and that was the scarcity of the Sweet Wrinkled varieties of canners' peas, proving the accuracy of the

statements made on this point in recent issues of HORTICULTURE.

There has been a decided drop in the price of onions within the past few weeks, and this will undoubtedly have a very undesirable influence on the demand for seed for the coming year, and it begins to look as if there would be some surplus at the end of the season notwithstanding the great shortage of last year's crops. It is pleasing to note that two or three of the members of the seed trade who have heretofore been hangers-on at the canners' conventions, refusing to join the association or contribute to its maintenance in any way, have finally decided this year to become members, and they are welcomed by all, including their competitors. It is only fair to say, however, that one or two still persistently refuse to come in, one of these being a very prominent grower who attracted universal attention by his tireless bustling for business. Possibly even this man may appreciate the humiliating position he is in, although thus far he has been impervious to criticism.

The California seed growers are on the wing and this week A. J. Pieters visited Chicago and Detroit on his way East. It is also reported that Charles P. Braslan is heading East in the wake of his friend and colleague and many of the others will undoubtedly follow them shortly.

J. S. Nave and E. W. Moore have started in the seed business in Owensboro, Ky., with E. O. Miller as manager.

CATALOGUES RECEIVED.

Kramer Brothers Foundry Co., Dayton, O.—Illustrated folder of Lawn Vases, Settees and Chairs.

F. E. Conine Nursery Co., Stratford, Conn.—Spring and fall 1908 Catalogue of Nursery Stock. An excellent selection.

Ralph M. Ward, New York.—Illustrated Wholesale Catalogue of Lily Bulbs. Worthy of careful reading by every forcer of lilies.

Arthur DeMeyer, Ghent, Belgium.—Wholesale Trade List for 1908. Profusely illustrated with plates showing the methods of handling and culture of the plants which this firm offers.

F. W. Dixon, Holton, Kans.—Twenty-first Annual Catalogue of Small Fruits. Strawberries are a specialty with this establishment and a group of luscious berries in colors adorns the cover.

Arthur Cowee, Berlin, N. Y.—The Twentieth Century Flower, being a list of the various superb strains of gladioli in the cultivation of which Mr. Cowee has no rival. Two lovely colored plates are inserted, also a number of half-tones.

Weeber & Don, New York.—Catalogue of Garden, Farm and Flower Seeds. This is a handsome catalogue throughout. There is a tempting nov-



GLADIOLI

I can satisfactorily supply your wants for Gladioli for forcing or outdoor planting. Mixtures, color sections or named varieties of exceptional beauty.

Write for Prices

ARTHUR COWEE

Gladiolus Specialist

Meadowvale Farm, BERLIN, N. Y.

HYACINTHS, TULIPS, NARCISSI

AND OTHER BULBS

ROMAN HYACINTHS and the true PAPER WHITE GRANDIFLORA

Ask for our Wholesale Trade List at Hillegom

K. VELTHUYS, Hillegom, Holland

Rep. by FELIX BOSCH, 260 Clarendon St., Boston.

ely list and the W. & D. Leviathan Mignonette forms an attractive cover illustration.

H. H. Berger & Co., New York.—Spring Catalogue for 1908. A characteristic Japanese scene forms the introductory cover topic. A large number of novelties in flower and vegetable seeds is included. Also Wholesale Catalogue for the trade only, listing many Japanese specialties

R. & J. Farquhar & Co., Boston, Mass.—Garden Annual for 1908. In style, arrangement, contents and illustration this catalogue stands in the front rank. The cover illustrations—Trollius Japonicus Excelsior and Tritoma hybrida Express—are fine examples of color work and the half-tones which enrich the descriptive pages in great profusion are most of them now used for the first time. The pages are noticeable for their conciseness and ease of reference, and the absence of superfluous verbiage. Vegetable and flower seeds and plants, bulbs, perennials, ornamental trees and shrubs and garden accessories are all fully covered.

Reports from those growers who have forced Formosa lilies during the past season show that good results have been obtained and that these bulbs have won approval for their healthiness and uniformity.

PLANT IMPORTS.

There were entered at the port of New York during the two weeks of January 22d to February 5th, inclusive, the following plants, etc.:

Via Rotterdam: W. Elliott & Sons, 50 bgs. grass seed; Maltus & Ware, 4 cs. flower roots, 14 bls. seed; J. P. Roosa, 24 cs. flower seed; Vaughan's Seed Store, 1 cs. plants.

From Germany: H. F. Darrow, 267 cs. lily of the valley pips, 2 cs. seed; P. Henderson & Co., 331 bgs. do.; Stumpff & Walter Co., 13 bgs. do. 1 cs. do.; J. M. Thorburn & Co., 4 bgs. do.; To Order, 2 pgs. do.

Via Havre: P. Henderson & Co., 35 pgs. seed; L. A. Consmiller, 50 pgs. plants; Otto Hann & Bros., 54 pgs. sea moss; P. A. Mahoney, 5 cs. plants; To Order, 16 cs. trees; Sundry Forwarders, 187 cs. plants.

Via Marseille: John Dunn, 1 box seed; Forwarders, 33cs. plants; To Order, 428 bgs. seed.

Via Southampton: H. F. Darrow, 39 pgs. seed, 25 cs. plants; McHutchison & Co., 42 cs. plants; August Rolker & Sons, 3 cs. do.

Via London: W. Elliott & Sons, 1 bag seed; J. M. Thorburn & Co., 84 bgs. garden seed, 1 cs. bulbs.

Via Liverpool: Maltus & Ware, 2 cs. plants.

From Glasgow: Peter Henderson & Co., 129 bls. grass seed.

From Copenhagen: Peter Henderson & Co., 15 bgs. seed; Vaughan's Seed Store, 1 box do.

Look through the Buyers' Directory and Ready Reference Guide. You will find some good offers there also

LINCOLN PANSY SEED

Blended with extra fine strains of foreign and home grown seed, giving grand rainbow colorings.

Half Trade Packet, 50 cents
Trade Packets, \$1.00

W. ELLIOTT & SONS

201 Fulton St. New York

WIBOLTT'S SNOWBALL CAULIFLOWER-SEED

No. 34 is the earliest of all Snowballs, the most compact, the surest header, is giving the largest and snow-white heads, and is the best keeper in dry-weather. Demand it through your seed-firm or direct from R. WIBOLTT, NAKSKOV, DENMARK

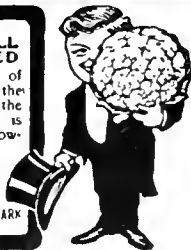

Cyclamen

Superb English Strain
Second to none in size of flowers
Giant Crimson.
" Pink.
" White.
" White with Claret base.
" Mauve.
" Salmon-Queen.
" New Fringed.

100 seeds \$1; 1000 seeds \$9.

H. E. FISKE SEED CO.

12 and 13 Fanueil Hall Square, BOSTON MASS.

ESTABLISHED 1802

Thorburn's Seeds

Send for our Wholesale Catalogue of Seeds for Florists and Market Gardeners, ready in a few days.

	Per doz.	Per 100
GLADIOLUS PRIMULINUS	\$8.00	\$60.00
PRIMULINUS HYBRIDS	3.00	20.00

J. M. THORBURN & CO.
33 Barclay St., through to 38 Park Place
NEW YORK

Everything of the Highest Grade

CANNAS
A Quarter of a
ANNAS
MILLION
in over
FIFTY VARIETIES
(True to name)
CATALOGUE FREE
ARTHUR T. BODDINGTON
Seedsman
342 W. H St., NEW YORK CITY

BRIDGEMAN'S SEED WAREHOUSE
RICKARDS BROS.

Props.

37 East 19th St., - NEW YORK CITY

BRASLAN SEED GROWERS CO.
GROWERS FOR THE
WHOLESALE TRADE ONLY
SAN JOSE, - - CALIFORNIA

Burpee's Seeds
PHILADELPHIA

Blue List of Wholesale Prices mailed only to those who plant for profit.

CAULIFLOWER SEED
CABBAGE
HJALMAR HARTMANN & CO.,
12 Stormgade,
COPENHAGEN, DENMARK.

BAMBOO CANES

They cost about 10 per cent. more than other kinds, and they are 10 times better.

STUMPP & WALTER CO.,

RELIABLE SEEDS—SOW NOW

	Tr.	6 Tr.
	Pkt.	Pkts.
Alyssum Carpet Queen real dwarf for pots only, no equal....	\$0.25	\$1.25
Begonia Gracilis Luminoza, new Erfordia, beautiful.....	0.50	2.50
Lobelia, new Trailing Hamburga	0.30	1.50
Petunia, Double Fringed Giants..	1.00	5.00
Single Fringed Giants.....	0.75	4.00
Phlox, best for pots, Fireball, Roseball, Snowball, each color.....	0.25	1.25
Salvia Fireball, new, a fine potter	0.50	2.50
Stocks, German 6 weeks: Blood-red, Lavender, Pink, Purple, White, each color.....	0.50	2.50
Verbena Mammoth: Pink, Purple, Scarlet, Striped, White, each	0.25	1.25

My New Price List Ready for the Asking

O. V. ZANCEN

Seedsman. HOBOKEN, N. J.

Best Quality Fall Bulbs

It is to your advantage to place your order early. Send us a list of your wants and we will quote you rock-bottom prices. Copy of our Florists' Bulb Catalogue will be sent upon request. Catalogues now ready.

VICK'S SUPERB PANSY SEED

All the best varieties in separate colors

VICK'S SUPERB MIXTURE

the best strain from all the leading named sorts

1-8 oz. 75c. 1-4 oz. \$1.50 Ounce \$5.00

JAMES VICK'S SONS, Rochester, N. Y.

CYCLAMEN

Farquhar's Giant Strain

Unsurpassed for size of flowers.

Giant Crimson Giant Pink
Giant White Finest Mixed
Giant Excelsior, White with Claret Base

100 seeds, \$1.25; 1000 seeds, \$10.00.

R. & J. FARQUHAR & CO.

6 & 7 So. Market St., Boston, Mass.

BRECK'S SEEDS

For Farmer, Market Gardener and Florist
New Crop High Grade
Catalogues mailed free on application

Joseph Breck & Sons Corp.
47-54 NO. MARKET ST., BOSTON, MASS.

JUST ARRIVED

LARGE SHIPMENT OF High-Grade SCOTCH SOOT.

We have the Stott Double Nozzle
THOMAS J. GREY CO.

32 & 33 So. Market St., BOSTON

C. C. MORSE & CO.

Address all communications to our permanent address
48 to 56 Jackson St., San Francisco, Cal.

The Largest Seed Growers in the United States

TOUGH AND STRONG

6 ft. long—\$1 per 100; \$6 per 1000; \$11 per 2000

50 Barclay St., New York

FORMOSA LILIUM LONGIFLORUM

Ends the Growers' trouble
Abso utely free from Disease

WASHINGTON STATE HORTICULTURAL ASSOCIATION.

Spokane was selected as the convention city for the fifth annual meeting of the Washington State Horticultural Association, which closed its three days' session at Walla Walla, Jan. 29 to 31, by the election of these officers for 1908:

President, H. M. Gilbert, North Yakima; first vice-president, A. F. Crowell, Spokane; second vice-president, H. Horan, Wenatchee; treasurer, William Ritz, Walla Walla; secretary, Levi G. Monroe, Spokane.

These prizes were awarded by the Walla Walla Fruit Growers' Association:

For best 10 boxes of apples packed for market variety, Yakima County Horticultural Society; for second best 10 boxes in the same class, Chelan County Horticultural Society; for best plate display, Spokane County Horticultural Society; for best box of apples, any commercial variety, Freewater, Ore.

The sessions took place in the Young Men's Christian Association rooms, where Mayor Kellogg of Walla Walla welcomed the 400 delegates and fruit growers from various parts of the state, the reply being by Prof. Cyrus L. Smith of Spokane, who was happy in his remarks, thanking the Walla Walla growers for their welcome and entertainment and arrangement of details. Following the annual address by E. L. Stewart, president of the society, F. A. Huntley, state horticultural inspector, in reviewing the fruit horticultural interests of the state, advocated some legislation to eliminate the multifarious handling of products by dealers, with its consequent profit. This was followed by an informal discussion.

C. L. Whitney, inspector of Walla Walla county, discussed "Fruit Growing in the Walla Walla Valley: Past, Present and Future." He was followed by J. M. Brown of North Yakima, who delivered a technical address on pear blight. He said in part:

"The most practical and the only sure preventive of this disease is to amputate the limbs from one to three feet below the least signs of any blight, and in this way get below the effect of the germ. The limbs cut off should be burned and the tools used in cutting the trees dipped in disinfected water to kill any germs that may be on them." This was followed by a general discussion.

Horticulture and Education.

Hon. Stephen B. L. Penrose, president of Whitman College at Walla Walla, delivered the principal address of the day, speaking on "Horticulture and Education." He said in part:

"I wish to offer some suggestions in the business of education, which is as much your business as it is mine. Every man should have at least one

son better than himself, and every woman should have one daughter better than herself. The man who does not advance the next generation makes a failure of his life from an evolutionary point of view, despite the fact that he might have attained success as a money-getter, a business man or a benefactor to the human race. What we need is that you men who believe in doing things in the best possible way should revive the art of fatherhood; that you should understand the seriousness and the sacredness of your obligation to the next generation.

"When it comes to the education of your children by other people I would suggest that you bear in mind three lessons. First, you should insist on training and experience in the teachers you employ; second, you should insist that the education should be conducted in a scientific fashion; third, you should bear in mind your own experience in the matter of fruit-raising, that you must spend money freely. If you wish your children to attain a maximum development, you must be willing to invest as much in their education as you would in your orchard, barn or cattle."

"The Canning Industry" was discussed, following a paper on the subject by J. B. Moran of North Yakima, after which R. Freeman, editor of the Northwest Farm and Home, North Yakima, spoke at length on "The Relation of the Honey Bee to the Orchard." This was followed by a discussion.

The second day's session included papers on "Natural Cultivation," J. F. Littooy of Wenatchee; "Orchard Care and Cultivation," C. L. Smith of Spokane; "Conservatism and Diversification in the Orchard," L. R. Freeman of North Yakima; "Spraying for the Codlin, Growing and Marketing," J. L. Dumas of Dayton; "Association Work and the Commercial Value of a Good Pack," E. H. Shepherd of Hood River, Ore.; "Fruit Handling," C. E. Nosler of Walla Walla. These papers were discussed at length.

Prof. W. S. Thornber, horticulturist of the Washington State College at Pullman, opened the program the last day with an address on general matters, which aroused a discussion. He was followed by Dr. J. Hedger of Kiona, with a talk on "Fruit Culture"; J. A. Rose of Kennewick, spoke on "The Cultivation of the Early Strawberry," and there was a general discussion, led by M. N. Richards of North Yakima, and A. J. Linville of Wenatchee on general association work. Prof. J. O. Jayne, irrigation investigator of the United States Department of Agriculture, also talked on "Practical Irrigation."

Following this the officers were elected for 1908 and Spokane chosen for the meeting in January, 1909, when the Spokane County Horticultural Society, of which H. W. Greenberg is president and L. G. Monroe, secretary, will give what promises to be the larg-

est and most important apple exhibition on the continent in the Spokane armory, which has a seating capacity of 5,000. The Spokane Chamber of Commerce, of which Frederick E. Goodall is president, has guaranteed cash prizes aggregating not less than \$1,000 in addition to trophies and ribbons for the winners in the various classes, which will be open to every grower in the State of Washington.

Secretary Monroe said on his return to Spokane from Walla Walla:

"The fourth annual meeting of the state society was the best attended and most interesting in the history of the society. We have in the neighborhood of 500 members, of which 155 are in Spokane county, and there is every reason that the first mentioned number will be increased to 1,000 before the end of the year.

It is also purposed to bring the convention of the National Irrigation Congress to Spokane in 1909. The Spokane country delegation to the meeting at Albuquerque, N. M., in September, will include 100 growers from various parts of the Inland Empire, who will take with them a train load of fruit grown in this part of the Pacific Northwest. Charles B. Reed is originator of the plan, which will be carried out by Martin J. Wessels of Spokane.

SOCIETY OF AMERICAN FLORISTS AND ORNAMENTAL HORTICULTURISTS.

National Flower Show Special Premium Offers.

John Breitmeyer's Sons, Detroit, Mich., offer \$25 first, \$15 second, for best fifty blooms of La Detroit rose.

Conard & Jones Co., West Grove, Pa., cash, premium not yet specified, \$25.

F. Dorner & Sons Co., LaFayette, Ind. Fifty bloms Winona carnation, first \$12, second \$8, third \$5.

Samuel Murray, Kansas City, Mo. Best six plants Cibotium Schiedei, not over ten inch pots, \$50.

John Young, New York. Cash, \$50; premium not yet specified.

W. N. RUDD.

Chairman Premium Committee.

PASADENA GARDENERS' ASSOCIATION.

The success of previous shows has encouraged the Pasadena Gardeners' Association to hold a Spring Flower Show on April 2, 3, 4, 1908, on a much larger scale, as everything looks bright and promising and there are many good and new things in the Floral Kingdom to draw from. The committee appointed to take charge of the arrangements is composed of Robert Pegg, chairman, Richard Thomas, secretary, John Blake, Otto Heutehey, Robert Kroll, A. T. Hanson, G. F. Neillsson, J. McGilvaray, G. Sawyer and Paul Janock. H. E. GEORGE.

CLUB AND SOCIETY NOTES.

The Louisiana Horticultural Society will meet at Minden February 20-22.

The Floral Society of New Orleans has disbanded and turned its fund in to the Horticultural Society.

The North Shore Horticultural Society will hold their rose and strawberry show on July 1; the summer show on August 26-27.

Pres. Kenyon L. Butterfield will address the Worcester County Horticultural Society, Worcester, Mass., on February 20 on rural progress.

The Tennessee Nurserymen's Association at their convention in Nashville, February 1, chose Frank McCord of Nashville, president; G. M. Bentley of Knoxville, secretary.

John Dunbar, Rochester, N. Y., will address the Massachusetts Horticultural Society, Boston, at their hall, on the 15th inst., at 11 a. m.; subject, "Hardy Conifers for Private Grounds."

The Wisconsin Horticultural Society at its annual meeting in Madison on February 4, elected R. J. Coe of Ft. Atkinson president, and Prof. F. Crane-field of Madison secretary, for 1908.

The Tennessee Horticultural Society at their annual meeting at Nashville elected the following as officers for the coming year: Pres., R. A. Wilkes; Secy., Charles A. Keffer, Knoxville; vice-pres., W. H. Fox, J. W. Garrett, W. P. Wade.

The Connecticut Pomological Society convened at Hartford on February 5 for a two days' session. The treasurer's report showed a good balance. Notable speakers presented papers on topics of interest to both grower and consumer. The laws concerning packing and shipping of fruit were discussed at length.

PERSONAL.

We are sorry to learn that Secretary John Young, of the New York Florists' Club, has sustained a fracture of the arm, caused by a fall on the ice.

Visitors in Boston: G. E. Baldwin of Carrillo & Baldwin, Secaucus, N. J.; Timothy McCarthy, Providence, R. I.; H. F. Littlefield, Worcester, Mass.

GLADIOLI

Write for 1908 trade list of Named Varieties, Color Sections and Choice Mixtures
First-Class Stock at Reasonable Prices
E. E. STEWART, Rives Junction, Mich.

LILIUM AURATUM
9-11 \$75 per 1000
ROSEUM and RUBRUM
9-11 \$65 per 1000
MULTIFLORUM
7-9 \$45 per 1000

D. RUSCONI, 128 West 6th St., CINCINNATI, OHIO

DREER'S SUPERB DOUBLE PETUNIAS



For half a century we have been making a specialty of **DOUBLE PETUNIAS** and our strain is accepted as second to none, either here or in Europe. We annually plant many thousand seedlings from which only the finest double fringed forms are selected for propagating purposes, thus improving the strain every season. We offer fifteen distinct varieties.

3-inch pots, 75c per doz.; \$6.00 per 100; the set of 15 for \$1.00.
2 1/2-inch pots, 60c per doz.; 4.00 per 100; the set of 15 for .75.
SEED OF OUR SUPERB STRAIN OF FRINGED PETUNIAS. Double, 75c per 500 seeds; \$1.50 per 1000 seeds. Single, 50c per trade packet; \$1.00 per 1-16 oz.; \$1.50 per 1/3 oz.

Our Quarterly Wholesale List offers a full line of seasonable Plants, Seeds and Bulbs.

HENRY A. DREER, PHILADELPHIA, PA.

ORCHIDS
Largest Importers, Exporters, Growers and Hybridists in the World
Sander, St. Albans, England
and 235 Broadway, Room 1
NEW YORK CITY

... ORCHIDS ...
Just to hand, C. Trianae, C. labiata, C. Mossiae, C. Intermedia, C. Schroderae, C. Speciosissima, C. Citrina, C. Gaskelliana, Laelia Auceps, L. Albida, L. majalis, L. Autumnalis, Epidendrum Vittelioum majus, E. Cooperianum, Oncidium Crispum, O. Varicosum, O. Cavendishianum, O. Luridum, Odonto. Citrosimum. To arrive in a short time, C. Dowiana, C. Aurea, C. Warneri, Miltonia Vexillaria.
CARRILLO & BALDWIN SECAUCUS, N. J.

ORCHIDS for Spring Delivery
NEW IMPORTATIONS
Cattleyas, Laelias, Oncidiums, etc.
WRITE FOR PRICES
Now is the time to Pot Orchids. Best Quality of Peat, Moss and Baskets on hand.
JOSEPH A. MANDA, 191 Valley Road, WEST ORANGE, N. J.

Write at once for our quotations on all
ORCHID IMPORTATIONS
FOR 1908 DELIVERY
JULIUS ROEHRS CO.,
The Orchid Nurseries, Rutherford, N. J.

ORCHIDS
We are at present booking orders for freshly imported Orchids for delivery 1908, of all leading kinds at reduced prices. We have just received the following:—
Oncidium Scarodes, O. Forbesii, O. Tigrinum and Sophronites, Grandiflora and Coccinea.
LAGER & HURRELL, Summit, N. J.

Keep Your Eye Open

FOR BARGAINS IN GOOD STOCK
See the **BUYERS' DIRECTORY** and **READY REFERENCE GUIDE.**
Pages 216, 217, 218, 219, 220.
Everything offered in this paper is listed there.
Look it over before buying and, in ordering please refer to advertisement in

HORTICULTURE

ORCHIDS
The largest importation of Orchids ever received in this country **WILL ARRIVE** next spring from Brazil, Colombia and Venezuela. If you intend putting in stock wait for these to arrive and we will quote the **Lowest Prices in America.**
ORDONEZ BROS., - Madison, N. J.

JAPANESE
THE YOKOHAMA NURSERY CO. NEW YORK.
31 BARCLAY STR. NEW YORK.
LILIES
PLANTS
BAMBOO STAKES

Prices Quoted in these Columns are for Dealers Only. When Writing to Advertisers Please Mention HORTICULTURE.

INDOOR CULTURE OF CARNATIONS.

Read before the Florists' Club of Philadelphia Feb. 4, 1903, by Esmond A. Harvey.

There is probably no cut flower of which the methods of culture have changed more in the past six or seven years than the carnation. When we began growing carnations, six years ago, we benched from the field about the middle of September, as this was the universal custom among Chester County carnation growers, and generally so throughout the United States, although some of the large growers around New York were practicing early planting. Now, from the middle of July to the middle of August is generally conceded to be the proper time to house from the field.

Indoor Culture.

The next development would naturally be indoor culture exclusively. To the writer's knowledge the first grower who practiced this method to any extent was Mr. Chas. W. Ward of Queens, L. I., who has always been a leader in the development of the "divine flower." I well remember seeing in 1903 at Mr. Ward's range a house of Enchantress that had been grown inside over summer and was struck with amazement at their magnificence. I do not think that I have ever seen them surpassed by any variety.

To succeed with indoor culture, strong, healthy cuttings should be put in the sand not later than February first; those potted up before February fifteenth are preferable. We first use two-inch pots, and when these are well filled with roots, plant in a bench four inches apart each way. Some growers again repot from three to four-inch pots and hold them in these until they are finally planted in the benches. When many plants are grown this method makes a great deal of work in watering, as the pots dry out very rapidly when it comes hot weather, and the young plants are also liable to become pot-bound before the benches are ready for them. When their growth is once stunted they are practically useless. At each transplanting all the weak plants should be set aside. A weak cutting may recover in the field but will never pay for itself grown inside.

As soon after Decoration Day as possible the old plants should be thrown out, the houses refilled with a good, rich compost and the young plants put in their final place.

Care in Summer.

Care must be taken with the watering. There is not much danger of over-watering in summer, still the benches should not be allowed to become soggy; far greater danger is in allowing the soil to get too dry. As soon as it begins to appear a light color on top it should be wet thoroughly, otherwise the plants will become hard and woody, and will not break freely. Although it is generally advised against shading, we believe a light shade is beneficial, and put a thin coat of whitening on every other row of glass about the first of July, and remove it early in September. This will aid materially in keeping down the temperature and will not cause a weak growth unless the plants are over-watered.

Full ventilation should be given

both day and night, except when a strong dry wind is blowing immediately on the plants, which dries out very rapidly both plants and soil, and is very likely to bring on an attack of red spider. This insect is about the only one that will cause trouble in the summer and a thorough spraying with cold water twice a week will, we have found, keep down this pest. Should they appear, however, the plants should be sprayed every day until they are clear, as the spider will cause a great deal of damage in a very short time, from which it will take a long time for the plants to recover.

Pinching.

The same care should be taken in pinching as in the field. Do not break back too high as this will cause a top-heavy growth, and the plants will be broken up by the spraying. As soon as the shoots begin to elongate and show the stem between the leaves, the top should be taken out, leaving three or four joints. Do not leave the plants two or three weeks and then break off all the shoots at once, but go over them every week, topping all the longest ones. This will make a more even growth and lessen the tendency toward cropping.

The benches should be frequently cultivated during the summer, both to keep down the weeds and to prevent the surface of the soil from becoming hard and baked.

Feeding.

If the soil was well fertilized with cow manure and bone meal before it was put in the benches, no feeding will be necessary during the summer. Through the fall we use top dressings of bone meal and sheep manure every two or three weeks, omitting all feeding through December. In January when the days become longer and we get more sunshine, we use a stronger and quicker-acting commercial fertilizer. Feeding with liquid manure would doubtless be beneficial, but we have never used this method.

If by the first of July the plants in the houses are as large as those in the field, you may consider that you have been successful, for, although through July and August the field plants will make a faster growth than the indoor stock, these will catch up later. There is always some check upon plants benched from the field, and often it is very severe if the conditions are not right. This is especially the case in a wet season.

Advantages of Indoor Culture.

One of the greatest advantages of indoor culture is the fact that we have control of the watering, and this is especially important since stem-rot has made its appearance. How often does it happen that half of the plants die

in the field and again half of those remaining, after they have been planted in the houses, and it is nearly spring before we begin to cut good flowers. With proper indoor culture the ravages of the dreaded stem-rot are reduced to a minimum. Another advantage of this method is that large flowers with long stems can be cut early in the fall, when they bring good prices and when none of the profits go into coal bills. A steadier cut is also assured through the winter, and the danger of getting a heavy crop, when prices are low, is diminished.

Some varieties are undoubtedly better suited to indoor growing than

BOXWOOD

Finest quality, \$17.50 per Cwt.

GALAX

Green, \$1.00 per 1000; \$7.50 per 10,000.
Bronze, \$1.00 per 1000; \$7.50 per 10,000.

Hardy Ferns, Best Grade, \$1.50 a 1000

LAUREL, MOSS, PRINCESS PINE, FESTOONING.

N. F. McCARTHY & CO. Telephone 5973-5974 Main **84 HAWLEY ST., BOSTON**
Largest Dealers in Florists' Supplies in New England

BOSTON FLORIST LETTER CO.

Manufacturers of FLORISTS' LETTERS

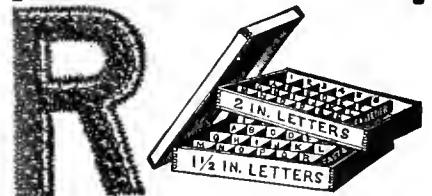

This wooden box nicely stained and varnished, 18x30x12, made in two sections, one for each size letter, given away with first order of 500 letters

Block Letters, 1 1/2 or 2 inch size per 100, \$2.
Script Letters, 3. Fastener with each letter or word. Used by leading florists everywhere and for sale by all wholesale florists and supply dealers

N. F. McCARTHY, Manager
66 Pearl Street, BOSTON, MASS.

The "Japana" Cut Flower Holder

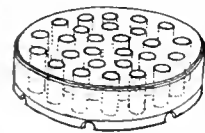

A handy article for florists. Sells to the trade on sight. Made of glass in three sizes. The "Anglais" Table Decoration, something entirely new, long needed. The florist and housewife will appreciate this article, as it simplifies the art of table decorating.

Ask for catalog.

M. V. CARNSEY, Dept. F,
130 Waiola Ave., La Grange, Ill.

KORAL SCRIPT LETTERS AND EMBLEMS

ONCE USED ALWAYS USED
For sale by all first class supply houses. Made by

KORAL MFG. CO.
26 Hawley St., Boston

E. A. BEAVEN

Southern Wild Smilax, Log Mosses,

Natural and Perpetuated — at Wholesale,
EVERGREEN, ALABAMA.

JOHN BREITMEYER'S SONS

Cor. Miami and Gratiot Aves.
DETROIT, MICH.

Artistic Designs . . .
High Grade Cut Blooms

We cover all Michigan points and good sections of Ohio, Indiana and Canada

P. J. and J. E. HAUSWIRTH

232 Michigan Ave.

CHICAGO

AUDITORIUM ANNEX Tel. Harrison 585

SAMUEL MURRAY Florist

Coates House Conservatory
1017 BROADWAY, KANSAS CITY, MO
Both 'Phones 2670 Mafn

FRED C. WEBER FLORIST

4326-28 ST. LOUIS, MO.
OLIVE STREET
Es'tablished 1873
Long Distance Phone Bell Lindell 676



WASHINGTON,
D. C.

GUDE'S

Geo. H. Cooke FLORIST

Connecticut Avenue and L Street
WASHINGTON, D. C.

The Park Floral Co.

J. A. VALENTINE
Pres.

DENVER, COLORADO

WILLIAM L. ROCK FLOWER CO.

KANSAS CITY, - MO.

will carefully execute orders for Kansas City and any town in Missouri or Kansas.

ALBANY, N. Y.

EYRES

Flowers or Design Work

DELIVERED IN ALBANY AND VICINITY ON TELEGRAPHIC ORDER.

11 NORTH PEARL ST., ALBANY, N. Y.

others. As a rule, the broad-foiled, strong growing kinds are best adapted to it. Mrs. Lawson and Winsor are notable examples; in fact, we would not attempt to grow them any other way.

Some Considerations.

The greatest objection offered to indoor culture is the fact that the June cut is lost. However, at this time carnations bring very low prices, and after all the problem is how to make each square foot of bench surface produce the most money. If we can make the returns through the fall and winter more than cover the loss during the summer by indoor culture we are foolish not to adopt it.

It is not urged that this method is an easy way to success in carnation growing. It certainly will not help that grower who is used to letting the plants take care of themselves. A little neglect is far more disastrous to indoor stock than to plants in the field.

Worth Trying.

I should not advise anyone to change their whole plant immediately from one method to the other, but first try a house or at least a bench, and prove for yourself which way is the better under your conditions. Some of the largest and best growers in the country practice indoor culture exclusively, and many others in part of their plant, and they certainly would not do so if it did not pay them. When any new method of doing things is taken up by the leaders in the trade, we owe it to the success of our business to at least see for ourselves whether there is anything in it; otherwise, we shall soon be bringing up the tail of the procession.



Send flower orders for delivery in

BOSTON

and all

NEW ENGLAND POINTS
THOS. F. CALVIN

124 Tremont St., Boston

TRANSFER

Your orders for flower or plant delivery in Eastern New England to

JULIUS A. ZINN,
2 Beacon St., Boston.

Fine Design Work a Specialty.

YALE

Orders for flower deliveries to Yale College and all other Connecticut

points carefully filled and delivered by

J. N. CHAMPION & COMPANY
1026 CHAPEL STREET NEW HAVEN, CONN.

ATLANTA FLORAL CO.

41 Peachtree Street, ATLANTA GEORGIA.

Florists Out of Town

Taking orders for delivery in New York or Vicinity can have them filled in best manner and specially delivered by

Thomas Young, Jr.

500 Fifth Ave., New York City
Telephone 847 Bryant.

ALEX. McCONNELL

571 FIFTH AVENUE
NEW YORK CITY

Telegraphic orders forwarded to any part of the United States, Canada, and all principal cities of Europe. Orders transferred or intrusted by the trade to our selection for delivery on steamships or elsewhere receive special attention.

Telephone Calls, 487 and 488 38th St.
Cable Address, ALEXCONNELL

William J. Smyth FLORIST

Cor. Michigan Ave. and 31st St., CHICAGO

We ship to all points in Illinois and Iowa.

Phones: Douglas 744, Douglas 523, Douglas 740

WILLIAM H. DONOHUE

FLORAL DECORATOR

17 East 28th St., New York

Special Attention to Theatre and Steamer Orders, and reliable deliveries guaranteed.

DAVID CLARKE'S SONS

Deliver orders from any part of the country to New York City

Or OUT-GOING STEAMERS

Write or telegraph

2139-2141 Broadway, New York
Telephone 1552-1553 Columbus

PROMPT DELIVERY IN BOSTON

AND ALL NEW ENGLAND POINTS

HOUGHTON & CLARK
396 Boylston St., Boston, Mass.

Flower Deliveries

In Brooklyn and other Long Island Points New York City, New Jersey, etc. At Theatres, Hotels, Steamers or Residences.

WILSON

Fulton St. and Greene Ave., Brooklyn, N.Y.

YOUNG & NUGENT

42 West 28 St., NEW YORK

"FLOWERS BY TELEGRAPH"

JACOB SCHULZ, 644 Fourth Ave., LOUISVILLE, KY.
Cut Flowers delivered promptly to any address.

Write, Telegraph or Telephone.
Cumberland and Home Phones 223 and 984

A Fine Assortment of
==AZALEAS==
 Extra fine lot of **FIREFLY** in bloom from
NOW UNTIL EASTER
 WRITE FOR PRICES
MAJOR BONNAFFON
 The best all 'round Yellow Chrysanthemum. Strong stools,
 \$5.00 per 100
W. W. EDGAR CO., Waverley, Mass.

ACACIA PUBESCENS
 A choice and seasonable specialty, long sprays of
 shimmering gold. Prices on application.
CHOICE VALLEY WHITE VIOLETS
 \$3.00 and \$4.00 per 100 \$1.50 per 100
S. S. PENNOCK - MEEHAN CO.
 1608-1620 Ludlow St. PHILADELPHIA
 "The" Wholesale Florists of Philadelphia

EVERYTHING SEASONABLE IN
CUT FLOWERS
EDWARD REID, Wholesale Florist
 1526 Ranstead St., PHILADELPHIA
 STORE CLOSES 3 P. M.

CHAS. W. MCKELLAR
 51 WABASH AVE., CHICAGO
 Western Headquarters for Choice Orchids
 Valley, Roses and all Cut Flowers

PETER REINBERG
 WHOLESALE
CUT FLOWERS
 51 Wabash Av., Chicago, Ill.
 In writing advertisers, mention Horticulture

CUT FLOWER BOXES
EDWARDS FOLDING BOX CO.
 MANUFACTURERS
 PHILADELPHIA, PA.

AMERICAN BEAUTY and all other
 ROSES
LILY OF THE VALLEY, CARNATIONS
WELCH BROS., 226 Devonshire St., Boston, Mass.

TRUMPET MAJORS
 Extra Quality Any Quantity
W. E. MCKISSICK WHOLESALE FLORIST
 PHILADELPHIA
 1619-1621 RANSTEAD ST.

DAILY CONSIGNMENTS
 From 40 to 60 Growers
 We can care for your cutflower wants to
 advantage.
E. F. WINTERSON CO.
 45-47-49 WABASH AVE., CHICAGO

J. J. HARTY & COMPANY
 WHOLESALE AND COMMISSION **FLORISTS**
 3112 G Street, N. W., Washington, D. C.

WHOLESALE FLOWER MARKETS—TRADE PRICES—Per 100 TO DEALERS ONLY

	CHICAGO Feb. 10	TWIN CITIES Feb. 10	PHILA. Feb. 11	BOSTON Feb. 13
ROSES				
Am. Beauty, Fancy and Special...	30.00 to 40.00	40.00 to 50.00	50.00 to 60.00	40.00 to 50.00
" Ex. 1a.....	25.00 to 30.00	35.00 to 40.00	30.00 to 40.00	12.00 to 20.00
" No. 1.....	15.00 to 25.00	20.00 to 30.00	15.00 to 30.00	6.00 to 10.00
" Lower grades.....	6.00 to 15.00	10.00 to 15.00	6.00 to 15.00	2.00 to 4.00
Bride, Maid, Fancy & Special.....	8.00 to 12.00	10.00 to 12.00	10.00 to 15.00	8.00 to 10.00
" Extra and No. 1.....	6.00 to 7.00	8.00 to 10.00	8.00 to 10.00	5.00 to 6.00
" Lower grades.....	3.00 to 5.00	4.00 to 6.00	4.00 to 8.00	1.00 to 2.00
Killarney, Richmond, Fan. & Sp.....	8.00 to 12.00	8.00 to 12.00	10.00 to 20.00	8.00 to 10.00
" Lower grades.....	4.00 to 6.00	4.00 to 6.00	3.00 to 8.00	1.00 to 3.00
Chatenay, Wellesley, Fan. & Sp.....	8.00 to 12.00	8.00 to 12.00	12.00 to 15.00	6.00 to 8.00
" Lower grades.....	4.00 to 8.00	4.00 to 6.00	3.00 to 8.00	1.00 to 4.00
Golden Gate, Ivory.....	6.00 to 10.00	6.00 to 12.00	3.00 to 12.00	1.00 to 5.00
CARNATIONS				
Fancy and Novelties.....	2.00 to 5.00	4.00 to 5.00	4.00 to 6.00	1.00 to 2.00
Ordinary.....	1.00 to 2.00	3.00 to 4.00	1.00 to 4.00 to 1.50
MISCELLANEOUS				
Violets.....	.50 to 1.00	1.00 to 1.25	.25 to 1.00	.25 to .50
Cattleyas.....	40.00 to 60.00	50.00 to 60.00	50.00 to 60.00	25.00 to 50.00
Cypripediums.....	1.00 to 15.00	12.00 to 16.00	12.50 to 15.00	8.00 to 12.00
Lilies.....	12.00 to 18.00	15.00 to 18.00	10.00 to 15.00	8.00 to 10.00
Lily of the Valley.....	2.00 to 4.00	3.00 to 5.00	2.00 to 5.00	1.00 to 2.00
Freesia.....	2.00 to 3.00	2.00 to 3.50	1.00 to 4.00	1.00 to 2.00
Roman Hy., Paper White Nar.....	2.00 to 4.00	3.00 to 4.00	1.00 to 3.00	1.00 to 2.00
Daffodils.....	2.00 to 4.00	2.00 to 4.00	1.50 to 3.00	1.00 to 1.50
Tulips.....	2.00 to 4.00	2.00 to 4.00	2.00 to 3.00	1.00 to 2.00
Mignonette.....	4.00 to 6.00	3.00 to 6.00	2.00 to 3.00	3.00 to 4.00
Gardenias.....	35.00 to 50.00	35.00 to 50.00	25.00 to 50.00	25.00 to 40.00
Lilac per bunch.....	1.50 to 2.00	.75 to 1.75	.50 to 2.50	1.00 to 1.50
Sweet Peas.....	.50 to 1.00	.50 to 1.50	.35 to 1.50	.50 to 1.00
Adiantum.....	.75 to 1.00	1.00 to 1.50	.75 to 1.50	1.00 to 1.50
Whitmanii Fronds..... to to	2.00 to 5.00	3.00 to 5.00
Smilax.....	10.00 to 12.00	14.00 to 18.00	12.50 to 20.00	10.00 to 12.00
Asparagus Plumosus, strings.....	35.00 to 50.00	40.00 to 60.00	50.00 to 75.00	25.00 to 50.00
" " & Spreo. (too bchs.)	35.00 to 50.00	40.00 to 60.00 to 50.00	25.00 to 50.00

THE FLORISTS' SUPPLY HOUSE OF AMERICA

Without a rival in knowledge of the requirements of the trade and the ability to supply them. Our New Illustrated Catalogue, recognized as a work of art unprecedented in its line for variety, novelty and completeness, tells the story fully, and if you have not yet sent for it, do so now.

'TIS FREE TO EVERYBODY IN THE TRADE

H. BAYERSDORFER & CO., 1129 Arch St., Philadelphia, Pa.

FLOWER MARKET REPORTS

BOSTON The wave of overproduction and accumulation of flowers has reached Boston with full force and conditions in the wholesale flower trade are unprecedented for this date. Compared with one year ago, values on many things are reduced 50 to 75 per cent., and the demand has shut down in all directions. Carnations and violets are now in the same predicament in which the bulbous stock has been traveling for some weeks. The latter is offered at unheard-of prices but buyers are not to be found even then.

A week has just passed **BUFFALO** that was very unsatisfactory to the grower, wholesaler and retailer, trade being simply at a standstill. The thermometer registered around the "zero" mark and the heavy fall of snow caused no little annoyance, and the shop window decorations being frozen up could attract no attention toward a sale for a blooming plant or spring flowers. It was a matter of the wholesaler carrying all the supply until the retailers were thawed out, the same being heavy and mostly in the carnation line. In the rose line the Beauty is not over-abundant but enough to fill all orders. Lilies and callas are plentiful, and lily of the valley sales are again on the quiet side. All bulbous stock, violets, peas, etc., are in good supply.

Business for the past **CHICAGO** week was very dull; in fact, the retailers assert they could not recall a poorer week at this time of the year. Roses are still quite scarce but other flowers are in abundance. This being Valentine's week, it should make a better showing, especially on violets. The warm spell will have a tendency to bring in a flood of bulb stock which is now almost a dead weight on the market. Good roses retain their prices but carnations have taken a decided drop.

Trade conditions **INDIANAPOLIS** for the past week were fair only. With no social affairs to look forward to, the future does not seem especially bright. Bulbous stock is coming in a little stronger now, daffodils selling the best. Owing to the cold weather the rose crop is off a little.

The cut flower market is badly demoralized, values being without stability on any line and the demand being totally inadequate to make impression on the heavy shipments of every sort of material. It would be useless to specialize, for all varieties and all grades are in practically the same predicament and the prospect for relief is exceedingly unpromising. The combination of slack demand and overproduction as at present existing is unprecedented for the month of February in the experience of the dealers here who are put to their wits' end to find an outlet for the accumulation.

The less said **PHILADELPHIA** about business the better. To repeat the remarks of the managers of the various whole-

sale markets, or of the leading retailers, would border on the sacrilegious. While everything was in over supply and demand at a minimum, still there was a silver lining to the cloud here and there. Flowers for funeral work, and these include quite a large line, roses, carnations, lily of the valley, stevia, lilies, and so on, were active as usual, although at lower prices. American Beauty roses sold fairly well, and these were never so fine nor so abundant before. It is estimated that the area under cultivation on this rose in this vicinity doubled last season. That, and the sunshiny weather has put the American Beauty within the reach of all this year and as its greatest perfection. Druggy and druggy are two excellent words to size up the situation on the balance of the market. The commission man now has to work four times as hard to move the stock, but he does not get four times as much for his labors. A scientific sliding scale adjustable to the service performed, high and low markets, might be in order.

FIRE RECORD.

The three violet houses of J. Todd of Poughkeepsie, N. Y., were destroyed by fire on January 29. The loss is estimated at \$3,000.

Fire which started from overheated pipes in the boiler room destroyed one house and contents belonging to G. H. Arnold, Braintree, Mass., on February 6. Loss about \$3,000.

A fire at the greenhouses of Henry P. Wagner, Mt. Vernon, N. Y., on February 5, caused a loss of nearly \$7,000, which is partially covered by insurance. Rapid work by the firemen saved two of the houses.

INCORPORATED.

Mitchell & Co., Waterville, Me.; G. A. Mitchell, F. E. Mitchell, G. E. Terry; capital, \$30,000.

Alki Floral Co., Seattle, Wash.; H. R. Anderson, J. R. Justice, E. O. Larson; capital, \$1,500.

Palisades Nurseries, Sparkill, N. Y.; Angus McGillivray, J. M. Stevens, James Cochran; capital, \$15,000.

The Satsuma Co., Newark, N. J.; M. C. Lefferts, D. G. Maynard, J. R. Lefferts, H. C. Hulbert, J. W. Plume; capital, \$150,000.

The Leedle Rosary Co., Springfield, O.; C. C. Leedle, C. P. Brunner, H. J. Roth, M. M. Livingston, James Sagar, Arthur C. Leedle will be manager of this new company.

BUSINESS CHANGES.

R. A. Betz, wire worker, Cincinnati, has moved to 128 E. 3rd street.

Henry Barton, florist, Westfield, Mass., has moved to 58 Elm street.

LEADING RETAIL FLORISTS—
Index by Towns will be found in
Buyers' Directory.

PHILADELPHIA NOTES.

The growers here are figuring on getting their coal cheaper on new contracts. The shut down on industrial activity has caused a large accumulation, and even the iron-clad coal monopoly is loosening up a little, rather than carry dead stock over to next winter.

The curbstone flower merchants were banished from Market and Chestnut street only—and the oft-recurring spasm of the authorities to enforce this edict of years and years ago lasts but a short time. At present there are plenty of these humble merchants to be seen on the two prohibited streets when the weather is mild.

Lord & Burnham Co. through their Philadelphia agent, D. T. Connor, have secured the contract for a new addition to the establishment of Stephen Mortensen, Southampton, consisting of one house, 43x265 ft. Mr. Mortensen intends to grow in same the new rose Mrs. Jardine. He has made a great name during the past twelve years as a grower of Bride and Bridesmaid roses.

If the supposed-to-be pure and spotless governments of the cities of Boston and Washington have been guilty of the petty graft of using plants and flowers for private purposes at public expense what about the airs those superior burghs put on when speaking of Philadelphia? No such graft as that has ever been heard of in the Quaker City.

Chas. F. Krueger, the Reading-terminal florist, is sending out a souvenir postal card to his customers, illustrating the interior and exterior of his place during the holidays. This is good advertising and quite in line with the up-to-date methods of this successful retailer.

In ordering goods please add, "I saw it in HORTICULTURE."

J. B. Murdoch & Co.
Wholesale Florists
FLORISTS' SUPPLIES
714 Penn Ave., PITTSBURG, PA.
Long Distance Phone 1435 Court.

J. KOPELMAN & CO.
Wholesale Dealers in
Cut Flowers and Florists' Supplies
EVERGREEN AND FERN LEAVES
OF ALL KINDS.
21 Washington St., PROVIDENCE, R. I.
Telephone Connection.

ROBERT J. DYSART,
Public Accountant and Auditor
Simple methods of correct accounting especially adapted for florists' use.
Books Balanced and Adjusted
Merchants Bank Building
28 STATE ST., - BOSTON
Telephone, Main 38

The KERVAN CO. 113 W. 28th ST.
New York
WHOLESALE DEALERS
Fresh cut Palmetto & Cycas Palm Leaves, Galax, Leucothoe, Ferns and Mosses. All Decorating Evergreen.

JOHN YOUNG
WHOLESALE FLORIST
 Finest American Beauties and Carnations
 51 West 28 St. - NEW YORK

FORD BROTHERS
 48 West 28th Street, NEW YORK
FINE ROSES FANCY CARNATIONS
 A Full Line of All CUT FLOWERS
 Telephone, 3870 or 3871 Madison Square

H. E. FROMENT,
 Wholesale Commission Florist,
 Choice Cut Flowers,
 57 West 28th St., :: NEW YORK.
 Telephones: 2200, 2201, Madison Square.

The Reliable Commission House
 Richmond Roses and Rich Flowers
 of all varieties
JOS. S. FENRICH
 110 W. 28th Street, New York
 Tel. 344-325 Madison Square

Established 1891 BUY FROM SHIP TO TRY **ME**
ALFRED H. LANGJAHR
 All Choice Cut Flowers In Season
 55 West 28th St., New York
 Telephone 3924 Madison Square.

JOHN I. RAYNOR
Wholesale Commission Florist SELLING AGENT FOR LARGEST GROWERS
 A full line of Choice Cut Flower stock for all purposes. Comprises every variety grown for New York market, at current prices
 TEL. 1998 MADISON SQUARE 49 W. 28 St., New York City

Walter F. Sheridan
 Wholesale Commission Dealer in
CHOICE CUT FLOWERS
 39 West 28th Street, New York
 Telephone: 3532-3533 Madison Square

HEADQUARTERS FOR NOVELTIES
ORCHIDS A SPECIALTY
 THE HIGHEST GRADE OF **VALLEY** ALWAYS ON HAND
 GARDENIAS, DAISIES, ROSES AND CARNATIONS
JAMES McMANUS, Telephone 759 Mad. Sq. 42 W. 28th St., New York

PHILIP F. KESSLER 55 & 57 W. 26th St., New York City
 Commission Dealer, Wholesale Buyer and Seller of
CUT FLOWERS
 Open from 5 a. m. to 6 p. m. Sunday till 10 a. m.
 Tel., 5243 and 2921 Madison Sq. Res., 345 J., Newtown.
Finest Lilies in the Market Every Day in the Year.

WHOLESALE COMMISSION FLORIST **J. K. ALLEN** 106 W. 28 ST. NEW YORK
 Telephone 167 Madison Sq.
 OPEN 6 A.M. DAILY
 We have a good regular outlet for seasonable flowers

NEW YORK QUOTATIONS PER 100—TO DEALERS ONLY

	Last Half of Week ending Feb. 8 1908	First Half of Week beginning Feb. 10 1908	Last Half of Week ending Feb. 8 1908	First Half of Week beginning Feb. 10 1908
Roses				
Am. Beauty, fan and sp.	30.00 to 75.00	40.00 to 50.00	25.00 to 50.00	25.00 to 50.00
" extra	15.00 to 20.00	10.00 to 15.00	6.00 to 8.00	6.00 to 8.00
" No. 1	12.00 to 15.00	8.00 to 12.00	8.00 to 10.00	6.00 to 10.00
" Lower grades	1.00 to 2.00	1.00 to 2.00	1.00 to 4.00	1.00 to 2.00
Bride, 'Maid, fan and sp.	8.00 to 12.00	6.00 to 10.00	1.00 to 2.00	1.00 to 2.00
" extra	5.00 to 6.00	1.00 to 5.00	1.00 to 2.00	1.00 to 2.00
" lwr. grds.	1.00 to 3.00	1.00 to 2.00	1.00 to 2.00	1.00 to 2.00
Killarney, Richmond, lacey & spec	10.00 to 15.00	6.00 to 10.00	2.00 to 5.00	2.00 to 4.00
" lower grades	2.00 to 4.00	1.00 to 2.00	1.00 to 2.00	1.00 to 2.00
Chatenay, Wellesley, fan, and spec	3.00 to 10.00	6.00 to 10.00	1.00 to 2.00	1.00 to 2.00
" lower grades	1.00 to 3.00	1.00 to 2.00	1.00 to 2.00	1.00 to 2.00
Golden Gate, Ivory	1.00 to 6.00	1.00 to 6.00	1.00 to 2.00	1.00 to 2.00
Carnations, Fancy and Novelties, ..	2.00 to 4.00	1.00 to 2.00	1.00 to 2.00	1.00 to 2.00
" Ordinary	1.00 to 2.00	1.00 to 2.00	1.00 to 2.00	1.00 to 2.00
Violets40 to .60	.20 to .25	1.00 to 1.50	1.00 to 1.50
Cattleyas			25.00 to 30.00	25.00 to 30.00
Cypripediums			6.00 to 8.00	6.00 to 8.00
Lilies			8.00 to 10.00	6.00 to 10.00
Lily of the Valley			1.00 to 4.00	1.00 to 2.00
Freesia			1.00 to 2.00	1.00 to 2.00
Ruman Hy., Paper White Nar. ...			1.00 to 2.00	1.00 to 2.00
Daffodils			1.00 to 1.50	1.00 to 2.00
Tulips			1.00 to 2.00	1.00 to 2.00
Tignonette			2.00 to 5.00	2.00 to 4.00
Gardenias			12.00 to 25.00	10.00 to 25.00
Lilac per bunch			1.00 to 1.50	1.00 to 1.50
Sweet Peas			50 to 75	50 to 75
Adiantum			1.00 to 1.50	1.00 to 1.50
Smilax			8.00 to 10.00	8.00 to 10.00
Asparagus Plumosus, strings...			25.00 to 40.00	25.00 to 40.00
" & Spreo. (100 bchs.)			10.00 to 15.00	10.00 to 15.00

B. S. SLINN, Jr.
 —WHOLESALE FLORIST—
 55 & 57 W. 26th St., New York City
 Tel., 3864 Madison Sq. Shipping Orders Solicited.
VIOLETS Roses and Carnations

TRAENDLY & SCHENCK
WHOLESALE FLORISTS
 Furnish best stock at fair prices all the year round Send for quotations on full orders
 Tel. 798-799 Madison Sq. 44 West 28th Street, New York City

Edward C. Horan
 Wholesale Florist
 55 WEST 28th ST.
 Tel 1462 Madison Square New York
 1463

Alexander J. Guttman
THE WHOLESALE FLORIST OF NEW YORK
 43 WEST 28th STREET
 PHONES. 1664--1665 MADISON SQUARE
ENOUGH SAID



HARDY CUT FERNS

Sphagnum Moss, Extra Large Bales, per bale, \$1.25. Fancy and Dagger Ferns our specialty. A trial order will convince you that we ship only first-class stock. Headquarters for Florists' supplies and wire work. All cut flowers in season. **BOXWOOD**, per bunch 35c, 50 lbs. \$7.50.

MICHIGAN CUT FLOWER EXCHANGE, INC., All 'phone connections 38-40 Broadway, Detroit, Mich.

FANCY and DAGGER
Extra fine, \$1.50 per 1000. Bronze and Green Galax, \$1.25 per 1000. Leucothoe Sprays, \$1.00 per 100, \$7.50 per 1000.

Headquarters in Western New York
FOR
ROSES, CARNATIONS
And all kinds of Seasonable Flowers
Wm. F. Kasting Co.
Wholesale Commission Florist, also Dealer in
Florists' Supplies and Wire Designs.
383-87 ELLICOTT ST.
BUFFALO, N. Y.
Give us a trial. We can please you.

FRANK S. HICKS & CO.
Wholesale Florists.
Open Now for Consignments of Cut Flowers.
52 West 28th Street, - New York City
Tel. 2920 Mad. Sq.

FRANK MILLANG
Wholesale Florist
Telegraphic Orders Filled and Delivered.
55-57 West 26th St., New York City.

Best Flowers
IN THE
BOSTON MARKET
N. F. McCarthy & Co.
84 Hawley St., BOSTON, MASS.
Send for Prices

HENRY M. ROBINSON & CO.
Wholesale and Commission
FLORISTS
Hardy Cut Evergreens and Florists' Supplies
15 Province St. and 9 Chapman Place,
BOSTON, MASS.

WHOLESALE FLOWER MARKETS. — TO DEALERS ONLY. PER 100.

	CINCINNATI Feb. 11	DETROIT Feb. 13	BUFFALO Feb. 10	PITTSBURG Feb. 10
ROSES				
Am. Beauty, Fan, 2nd Sp.....	30.00 to 40.00	50.00 to 65.00	40.00 to 50.00	40.00 to 50.00
" Extra.....	20.00 to 30.00	25.00 to 30.00	20.00 to 30.00	25.00 to 35.00
" No. 1.....	10.00 to 15.00	20.00 to 25.00	10.00 to 15.00	10.00 to 15.00
" Lower grades.....	4.00 to 6.00	6.00 to 15.00	5.00 to 10.00	10.00 to 12.00
Bride, 'Maid, F. & S.....	4.00 to 10.00	10.00 to 12.00	10.00 to 5.00	10.00 to 8.00
" Extra.....	6.00 to 8.00	8.00 to 10.00	8.00 to 10.00	10.00 to 8.00
" Low. gr.....	4.00 to 5.00	6.00 to 8.00	4.00 to 6.00	6.00 to 6.00
Killarney, Richmond, Fan. & Sp...	8.00 to 10.00	8.00 to 10.00	10.00 to 15.00	10.00 to 12.00
" Lower grades.....	4.00 to 6.00	6.00 to 8.00	6.00 to 10.00	6.00 to 10.00
Chateaub, Wellesley, Fan. & Sp...	8.00 to 10.00	8.00 to 10.00	12.00 to 15.00	8.00 to 12.00
" Lower grades.....	4.00 to 6.00	6.00 to 8.00	6.00 to 10.00	6.00 to 6.00
Golden Gate, Ivory.....	6.00 to 8.00	8.00 to 10.00	4.00 to 10.00	6.00 to 8.00
CARNATIONS				
Fancy and Novelties.....	3.00 to 4.00	4.00 to 4.00	3.00 to 4.00	3.00 to 4.00
Ordinary.....	2.00 to 3.00	2.00 to 4.00	2.00 to 3.00	1.50 to 2.00
MISCELLANEOUS				
Violets.....	50 to 75	1.00 to 1.50	.50 to 1.00	.25 to .75
Camellias.....	30.00 to 60.00	35.00 to 50.00 to	50.00 to 75.00
Cyripediums.....	12.00 to 15.00	8.00 to 10.00	10.00 to 15.00 to 15.00
Lilies.....	12.00 to 15.00	20.00 to 25.00	4.00 to 15.00	12.50 to 15.00
Lily of the Valley.....	3.00 to 4.00	3.00 to 4.50	3.00 to 4.00	3.00 to 4.00
Freesia.....	2.00 to 3.00 to	2.00 to 3.00	3.00 to 4.00
Roman Hy., Paper White Nar.....	2.00 to 3.00	3.00 to 4.00	2.00 to 3.00	1.50 to 4.00
D. Rodils.....	3.00 to 4.00 to	3.00 to 3.50	3.00 to 3.00
Tulips.....	3.00 to 4.00 to	2.00 to 3.00	3.00 to 6.00
Mignonette.....	4.00 to 6.00	8.00 to 10.00	3.00 to 5.00	3.00 to 3.00
Gardenias.....	35.00 to 50.00 to40 to 1.00 to
Lilac per bunch.....	1.50 to 2.00 to50 to 1.00	.75 to 1.00
Sweet Peas.....	.75 to 1.00 to to75 to 1.25
Adiantum..... to 1.00	1.00 to 2.00 to to 1.00
Whitman's Floods..... to to to to
Smilax..... to 12.50 to 15.00 to 15.00 to 12.50
Asparagus Plumosus, strings.....	40.00 to 50.00	50.00 to 75.00	50.00 to 60.00	30.00 to 50.00
" " & Spren (100 bchs.)	25.00 to 35.00	30.00 to 50.00	25.00 to 40.00	30.00 to 60.00

SAMUEL A. WOODROW
WHOLESALE PLANTSMAN
Palms, Large and Small Ferns, etc.
53 West 30th Street, NEW YORK
Telephone 2083 Madison

WILLIAM H. KUEBLER
Brooklyn's Foremost and Best
WHOLESALE COMMISSION HOUSE
A First Class Market for all CUT FLOWERS
28 Willoughby St., Brooklyn, N. Y.
Tel. 4591 Main

CLEARY'S HORTICULTURAL CO.
Management AMBROSE T. CLEARY
Wholesale Contracting, Jobbing, Auction
HORTICULTURAL PRODUCTS
of every description.
Consignments Received. Surplus Stock Converted.
62 Vesey St., NEW YORK

Moore, Hentz & Nash,
Wholesale Commission Florists,
55 and 57 West 26th Street,
Telephone No. 756
Madison Square. New York.

H. C. BERNING
Wholesale Florist
1402 Pine Street, ST. LOUIS, MO.

Alex Mann, Jr. Co. Inc.
Wholesale Dealer in
Florists' Supplies and Cut Flowers
White Doves, \$9.00 per doz.
Galax Leaves.
1125 Polk Street, San Francisco, Cal.

A. MOLTZ
Will purchase flowers on order in
N. Y. market and ship carefully at
prevailing wholesale prices. Address
55-57 West 26th Street, New York City

REED & KELLER
122 West 25th St., New York
Florists' Supplies
We manufacture all our
Metal Designs, Baskets, Wire Work & Novelties
and are dealers in
Glassware Decorative Greens and Florists' Requisites

In writing to Advertisers kindly mention Horticulture

Buyer's Directory and Ready Reference Guide

Advertisements under this head, one cent a word. Initials count as words.

Regular advertisers in this issue are also listed under this classification without charge. Reference to List of Advertisers will indicate the respective pages.

Buyers failing to find what they want in this list will confer a favor by writing us and we will try to put them in communication with reliable dealers.

ACCOUNTANT

R. J. Dysart, 28 State St., Boston.
For page see List of Advertisers.

ALTERNANTHERAS

Red Alternantheras at 40 cents per 100.
C. W. Moeckel, 17 Summer St., Fitchburg, Mass.

AQUARIUMS

Aquarium plants the year round. Wholesale and retail. Send for price list. Schmid's Emporium of Pets, 712 12th Street, Washington, D. C.

ARAUCARIAS

Godfrey Aschmann, 1012 Ontario St., Philadelphia, Pa.
For page see List of Advertisers.

ASPARAGUS

Asparagus Plumosa, 2 in. pots. Fine plants, \$3.00 per 100; \$25.00 per 1000. Cash with order or good reference. Erie Floral Co., Erie, Pa.; or, Wm. F. Kasting Co., 385 Elliott St., Buffalo, N. Y.

AUCTION SALES

Clery's Horticultural Co., 62 Vesey St., New York.
Horticultural Products of Every Description.
For page see List of Advertisers.

Sales every Tuesday and Friday. If you cannot attend send bids and shipping instructions. Catalogue on application. N. F. McCarthy & Co., 84 Hawley St., Boston.

AZALEAS

A. Leuthy & Co., Perkins St. Nurseries, Roslindale, Mass.
For page see List of Advertisers.

W. W. Edgar Co., Waverley, Mass.
For page see List of Advertisers.

August Rolker & Sons, New York, 31 Barclay St., or P. O. Box 752.
For page see List of Advertisers.

BAMBOO CANES

Stumpp & Walter Co., 50 Barclay St., New York.

For page see List of Advertisers.

Yokohama Nursery Co., 31 Barclay Street, New York.

For page see List of Advertisers.

BAY TREES.

Specimens and pairs, all sizes. Send for prices. N. F. McCarthy & Co., 84 Hawley St., Boston.

Bay Trees and Box Trees, standards and pyramids. All sizes. Price list on application. J. Roebers Co., Rutherford, N. J.

BOILERS

BOILERS. "Burnham" Boilers made for greenhouse heating. Lord & Burnham, 1133 Broadway, N. Y.

BOXWOOD

A. Leuthy & Co., Perkins St. Nurseries, Roslindale, Mass.
For page see List of Advertisers.

Henry M. Robison & Co., 15 Province St., Boston.
For page see List of Advertisers.

N. F. McCarthy & Co., 84 Hawley St., Boston, Mass.

For page see List of Advertisers.

BUILDING MATERIAL

BUILDING MATERIAL of all description for All Cypress, Semi-Iron, Iron Frame or Truss Homes. Hot Bed Sash and Frames. Lord & Burnham Co., 1133 Broadway, N. Y.

BULBS AND TUBERS

Joseph Breek & Sons, 47-54 N. Market St., Boston.

For page see List of Advertisers.

J. M. Thornburn & Co., 33 Barclay St., New York.

For page see List of Advertisers.

A. T. Boddington, 342 W. 14th St., N. Y.
For page see List of Advertisers.

Rickards Bros., 37 East 19th St., New York.
For page see List of Advertisers.

H. F. Michell Co., Philadelphia.
For page see List of Advertisers.

H. E. Fiske Seed Co., Faneuil Hall Sq., Boston.
For page see List of Advertisers.

James Vlek's Sons, Rochester, N. Y.
Full Bulbs.

For page see List of Advertisers.

D. Rusconi, 128 W. Sixth St., Cincinnati, O.
Lillum Auratum, Roseum, Multiflorum.
For page see List of Advertisers.

Ang. Rolker & Sons, 31 Barclay St., New York.

Seasonable Import Plants and Bulbs.
For page see List of Advertisers.

K. Velthuys, Hillegom, Holland, Represented by Felix Bosch, 260 Chrendon St., Boston.

Bulbs French and Dutch.

For page see List of Advertisers.

Dwarf Pearl tuberoses, 50,000 No. 2, very fine bulbs, 4 in. in circumference. Write for prices. T. V. Rivenbark, Wallace, N. C.

CANNAS

The Conard & Jones Co., West Grove, Pa.
For page see List of Advertisers.

A. T. Boddington, 342 W. 14th St., New York.

For page see List of Advertisers.

Good Robusta, dark-leaved, at \$1.50 per 100; large clumps Burbank, White Berat and Cinnabar, at \$2.00 per 100; Pennsylvania, at \$2.50 per 100. C. W. Moeckel, 17 Summer St., Fitchburg, Mass.

CARNATIONS

The H. Weber & Sons Co., Oakland, Md.
Seedling Carnation Treader.
For page see List of Advertisers.

Rooted Cuttings

F. Dorner & Sons Co., Lafayette, Ind.
For page see List of Advertisers.

S. S. Skidelsky, 1741 N. 18th St., Philadelphia.

For page see List of Advertisers.

Chicago Carnation Co., Joliet, Ill.

For page see List of Advertisers.

F. R. Pierson Co., Tarrytown, N. Y.
Winsor and White Enchantress Rooted Cuttings.

For page see List of Advertisers.

H. A. Jahn, New Bedford, Mass.

Carnation Lloyd.

For page see List of Advertisers.

F. H. Kimberly, 631 Townsend Ave., New Haven, Conn.

For page see List of Advertisers.

CARNATIONS — Rooted Cuttings — Continued

John E. Haines, Bethlehem, Pa.
Carnations Imperial and Pink Imperial.
For page see List of Advertisers.

A. N. Pierson, Cromwell, Ct.
Carnation Winsor.
For page see List of Advertisers.

Charles H. Potty, Madison, N. J.
For page see List of Advertisers.

The Leo Niessen Co., 1209 Arch St., Philadelphia, Pa.
For page see List of Advertisers.

Welch Bros., 226 Devonshire St., Boston.
Carnation White Fair Maid.

Send for list of the best carnation cuttings. Wm. Ehmann, Jr., Corfu, N. Y.

Unrooted Lawson, Boston Market, \$5.00 per 1000; Hill, \$4.00 per 1000. Wm. Ehmann, Jr., Corfu, N. Y.

Carnation cuttings of all the leading varieties at the same price as any reliable firm. Write for prices before you look elsewhere. Wm. F. Kasting Co., 385 Elliott St., Buffalo, N. Y.

CHRYSANTHEMUMS

W. W. Edgar Co., Waverley, Mass.
For page see List of Advertisers.

CONIFERS

John Waterer & Sons, Ltd., American Nursery, Bagshot, Eng.
For page see List of Advertisers.

Write for prices on all choice ornamental conifers. N. F. McCarthy & Co., 84 Hawley St., Boston, Mass.

CUT FLOWER BOXES.

Edwards Folding Box Co., Philadelphia.
For page see List of Advertisers.

Folding cut flower boxes, the best made. Write for list. Holton & Hunkel Co., Milwaukee, Wis.

DAHLIAS

David Herbert & Son, Atco, N. J.
For page see List of Advertisers.

J. L. Moore, Northboro, Mass.
For page see List of Advertisers.

DECORATIVE PLANTS

A. Leuthy & Co., Roslindale, Mass.
For page see List of Advertisers.

FERNS

A. Leuthy & Co., Roslindale, Mass.
For page see List of Advertisers.

H. H. Barrows & Son, Whitman, Mass.
Nephrolepis Whitmanii.
For page see List of Advertisers.

Godfrey Achmann, 1012 Ontario St., Philadelphia, Pa.
For page see List of Advertisers.

John Scott, Brooklyn, N. Y.
For page see List of Advertisers.

Baur Floral Co., Erie, Pa.
For page see List of Advertisers.

Whitman ferns, 9 in., \$1.00; 8 in., 80c. Hy. Ernst & Son, Washington, Mo.

Nephrolepis Exaltata Bostoniensis, fine young plants, \$10.00 per 1000.

N. Elegantiissima, young plants \$15.00 per 1000. Send for price list. Soar Bros., Little River, Fla.

For List of Advertisers See Page 220

FERTILIZERS

Pulverized Manure Co., 31 Union Stock Yards, Chicago, Ill.
Wizard Brand Cattle Manure.
 For page see List of Advertisers.

Thos. J. Grey & Co.,
 32 and 33 South Market St., Boston.
 High-Grade Scotch Soot.
 For page see List of Advertisers.

FLORAL PHOTOGRAPHS

Floral Photographs. Foley's 226-228 1-2 Bowery, New York.

FLORISTS' LETTERS.

Boston Florist Letter Co., 66 Pearl St., Boston, Mass.
 For page see List of Advertisers.

Kocel Mfg. Co., 26 Hawley St., Boston.
 For page see List of Advertisers.

FLORISTS SUPPLIES

H. M. Robinson & Co., 15 Province St. and 9 Chapman Pl., Boston, Mass.
 For page see List of Advertisers.

The Keivan Co., 113 W. 28th St., N. Y.
 Decorative Evergreens.
 For page see List of Advertisers.

Reed & Keller, 122 W. 25th St., New York.
 For page see List of Advertisers.

J. B. Murdoch & Co., 714 Penn Ave., Pittsburg, Pa.
 For page see List of Advertisers.

H. Bayersdorfer & Co., 1129 Arch St., Philadelphia.
 For page see List of Advertisers.

Alex. Mann, Jr., Co., 1125 Polk St., San Francisco, Calif.
 For page see List of Advertisers.

FLOWERS BY TELEGRAPH

Park Floral Co., Denver, Colo.
 For page see List of Advertisers.

J. N. Champion & Co., 1026 Chapel St., New Haven, Conn.
 For page see List of Advertisers.

George H. Cooke, Washington, D. C.
 For page see List of Advertisers.

Gude Bros. Co., 1214 F St., Washington, D. C.
 For page see List of Advertisers.

Atlanta Floral Co., Atlanta, Ga.
 For page see List of Advertisers.

P. J. & J. E. Hauswirth, 232 Michigan Ave., Chicago.
 For page see List of Advertisers.

William J. Smyth, Michigan Ave. and 31st St., Chicago.
 For page see List of Advertisers.

Jacob Scholz, 644 4th Ave., Louisville, Ky.
 For page see List of Advertisers.

Thos. F. Galvin, 124 Tremont St., Boston.
 For page see List of Advertisers.

Julius A. Zinn, 2 Beacon St., Boston.
 For page see List of Advertisers.

Houghton & Clark, 396 Boylston St., Boston.
 For page see List of Advertisers.

Sidney Hoffman, 59-61 Massachusetts Ave., Boston.
 For page see List of Advertisers.

J. Breitmeyer's Sons, Miami and Gratiot Aves., Detroit, Mich.
 For page see List of Advertisers.

Samuel Murray, 1017 Broadway, Kansas City, Mo.
 For page see List of Advertisers.

Wm. L. Rock Flower Co., 1116 Walnut St., Kansas City, Mo.
 For page see List of Advertisers.

Fred C. Weber, 4326-28 Olive St., St. Louis, Mo.
 For page see List of Advertisers.

H. G. Eyres, 11 N. Penri St., Albany, N. Y.
 For page see List of Advertisers.

David Clarke's Sons, 219-2141 Broadway, New York.
 For page see List of Advertisers.

FLOWERS BY TELEGRAPH —

Continued

W. H. Donohoe, 17 E. 28th St., New York.
 For page see List of Advertisers.

Alex. McConnell, New York.
 For page see List of Advertisers.

Robert G. Wilson, Fulton St. & Greene Av., Brooklyn, N. Y.
 For page see List of Advertisers.

Thomas Young, Jr., 500 Fifth Ave., N. Y.
 For page see List of Advertisers.

Young & Nugent, 42 W. 28th St., N. Y.
 For page see List of Advertisers.

FLOWER POTS

W. H. Ernest, 28th and M Sts., Washington, D. C.
 For page see List of Advertisers.

A. H. Hews & Co., Cambridge, Mass.
 For page see List of Advertisers.

Hilfinger Bros., Ft. Edward, N. Y.
 For page see List of Advertisers.

Paper pots for all early vegetables. Two inch pots \$1.00 a thousand; three inch \$1.25; four inch \$1.60. P. B. Crosby, Catsville, Md.

FORMOSA LILIUM LONGI-FLORUM

???

For page see List of Advertisers.

GALAX

Michigan Cut Flower Co., 38 and 40 Broadway, Detroit, Mich.
 For page see List of Advertisers.

Finest green and bronze Galax in any quantity at lowest figures. N. F. McCarthy, 84 Hawley St., Boston.
 For page see List of Advertisers.

GERANIUMS

R. Vincent Jr. & Sons Co., White Marsh, Md.
 New and Standard Varieties.
 For page see List of Advertisers.

GLADIOLI

Arthur Cowee, Meadowvale Farm, Berlin, New York.
 For page see List of Advertisers.

J. L. Moore, Northboro, Mass.
 For page see List of Advertisers.

Gladioli. Write for leaflet. B. Hammond Tracy, Cedar Acres, Wenham, Mass.

GLASS

Boston Plate & Window Glass Co., Boston.
 For page see List of Advertisers.

Standard Plate Glass Co., 26-30 Sudbury St., Boston.
 For page see List of Advertisers.

Metropolitan Material Co., 1398-1408 Metropolitan Ave., Brooklyn, N. Y.
 For page see List of Advertisers.

S. Jacobs & Sons, 1365-79 Flushing Ave., Brooklyn, N. Y.

Foley Mfg. Co., between Western Ave. and 26th St., Chicago, Ill.

GLASS, High Grade, Double Thick Greenhouse Glass. Lord & Burnham, 1133 Broadway, N. Y.

GLAZING POINT

H. A. Dreer, Philadelphia, Pa.
 For page see List of Advertisers.

GLAZING POINTS, Lord & Burnham Special Glazing Nails (Points). Lord & Burnham, 1133 Broadway, N. Y.

GREENHOUSE BUILDING MATERIAL.

Lord & Burnham Co., 1133 Broadway, New York.
 For page see List of Advertisers.

Pierson U-Bar Co., 1 Madison Sq., N. Y.
 For page see List of Advertisers.

Hitchings & Co., 1170 Broadway, N. Y.
 For page see List of Advertisers.

A. T. Stearns Lumber Co., Neponset, Boston.
 For page see List of Advertisers.

King Construction Co., N. Tonawanda, New York.
 For page see List of Advertisers.

J. C. Moulner Co., 117 East Blackhawk St., Chicago, Ill.
 For page see List of Advertisers.

Foley Mfg. Co., between Western Ave. and 26th St., Chicago, Ill.
 For page see List of Advertisers.

I. Cassidy, Summer Ave. and Erie R. R., Newark, N. J.
 For page see List of Advertisers.

W. H. Lutton, Jersey City, N. J.
 For page see List of Advertisers.

Geo. B. Doane, 18 Midway St., Boston.
 Iron Pipe.
 For page see List of Advertisers.

Metropolitan Material Co., 1398-1408 Metropolitan Ave., Brooklyn, N. Y.
 For page see List of Advertisers.

S. Jacobs & Sons, 1365-79 Flushing Ave., Brooklyn, N. Y.

GREENHOUSE CONSTRUCTION

GREENHOUSE CONSTRUCTION, Semi-Iron Greenhouse, New Truss Houses and Iron Frame Houses. Lord & Burnham, 1133 Broadway, N. Y.

J. A. Payne, 260-274 Culver Ave., Jersey City, N. J.
 For page see List of Advertisers.

I. Cassidy, Summer Ave. and Erie R. R., Newark, N. J.
 For page see List of Advertisers.

Foley Mfg. Co., between Western Ave. and 26th St., Chicago, Ill.

W. H. Lutton, Jersey City, N. J.
 For page see List of Advertisers.

GREENHOUSE HOSE

Mineralized Rubber Co., 18 Cliff St., N. Y.
 For page see List of Advertisers.

GUTTERS

GUTTERS, Cast Iron Gutters, L. & B. Improved V Shaped Gutter with drip gutter attachment. Lord & Burnham, 1133 Broadway, N. Y.

HAIL INSURANCE

Florists' Hall Asso. of America. J. G. Esler, Saddle River, N. J.
 For page see List of Advertisers.

HARDY FERNS AND SUPPLIES

H. M. Robinson & Co., 15 Province St. and 9 Chapman Pl., Boston, Mass.
 For page see List of Advertisers.

The Kervan Co., 113 W. 28th St., N. Y.
 For page see List of Advertisers.

Michigan Cut Flower Exchange, 38 and 40 Broadway, Detroit, Mich.
 Fancy Ferns.
 For page see List of Advertisers.

A full line of ferns, galax, and all wild greens. N. F. McCarthy & Co., 84 Hawley St., Boston.
 For page see List of Advertisers.

HEATING APPARATUS
Lord & Burnham Co., 1133 Broadway, New York.
 For page see List of Advertisers.

Pierson U-Bar Co., 1 Madison Sq., N. Y.
 For page see List of Advertisers.

Hitchings & Co., 1170 Broadway, N. Y.
 For page see List of Advertisers.

John A. Payne, 260-274 Culver Ave., Jersey City, N. J.
 For page see List of Advertisers.

In writing to Advertisers kindly mention Horticulture

HELP FURNISHED

Thos. H. Bambrick, 34 S. 7th St., Phila.
For page see List of Advertisers.

HORICUM

Hammond's Paint & S. S. Wks., Fishkill-on-Hudson, N. Y.
For page see List of Advertisers.

HOT-BED SASH

The A. T. Stearns Lumber Co., Neponset, Mass.
For page see List of Advertisers.

Pierson U-Bar Co., 1 Madison Sq., N. Y.
For page see List of Advertisers.

Hitchings & Co., 1170 Broadway, N. Y.
For page see List of Advertisers.

Lord & Burnham Co., 1133 Broadway, N. Y.
For page see List of Advertisers.

Foley Mfg. Co., between Western Ave. and 26th St., Chicago, Ill.

INSECTICIDES.

Nicotinic kills all greenhouse pests.
P. R. Palethorpe Co.,
Eleventh St., Owensboro, Ky.
For page see List of Advertisers.

B. G. Pratt Co., 11 Broadway, New York.
For page see List of Advertisers.

For Sale—Tobacco Stems and Tobacco Dust. Stems, 1-2c. per lb. in bale lots. Dust, 2c. per lb. in case lots. Weight of bale or case, 300 to 400 lbs. each. S. R. Levy, Binghamton, N. Y.

JAPANA CUT FLOWER HOLDER

M. V. Garnsey, 139 Waiola Ave.,
La Grange, Ill., Dept. F.
For page see List of Advertisers.

KENTIAS

A. Leuthy & Co., Roslindale, Mass.
For page see List of Advertisers.

Godfrey Aschmann, 1012 W. Ontario St.,
Philadelphia.
For page see List of Advertisers.

LEADING RETAIL FLORISTS

Park Floral Co., Denver, Colo.
For page see List of Advertisers.

George H. Cooke, Washington, D. C.
For page see List of Advertisers.

Gude Bros. Co., 1214 F St.,
Washington, D. C.
For page see List of Advertisers

Atlanta Floral Co., Atlanta, Ga.
For page see List of Advertisers.

P. J. & J. E. Hauswirth, 232 Michigan Ave.,
Chicago.
For page see List of Advertisers.

William J. Smyth, Michigan Ave. and 31st
St., Chicago.
For page see List of Advertisers.

Jacob Schulz, 644 4th Ave., Louisville, Ky.
For page see List of Advertisers

Thos. F. Galvin, 124 Tremont St., Boston.
For page see List of Advertisers.

Julius A. Zinn, 2 Beacon St., Boston.
For page see List of Advertisers.

Houghton & Clark, 396 Boylston St.,
Boston.
For page see List of Advertisers.

Sidney Hoffman, 59-61 Massachusetts Ave.,
Boston.
For page see List of Advertisers.

J. Bretmeyer's Sons, Detroit, Mich.
For page see List of Advertisers.

Samuel Murray, 1017 Broadway,
Kansas City, Mo.
For page see List of Advertisers.

Wm. L. Rock Flower Co., 1116 Walnut
St., Kansas City, Mo.
For page see List of Advertisers.

Fred C. Weber, 4326 Olive St., St. Louis,
Mo.
For page see List of Advertisers.

J. N. Champion & Co., 1029 Chapel St.,
New Haven, Conn.
For page see List of Advertisers.

LEADING RETAIL FLORISTS—**Continued**

H. G. Eyres, 11 N. Pearl St., Albany, N. Y.
For page see List of Advertisers.

David Clarke's Sons, 2139-2141 Broadway,
New York.
For page see List of Advertisers.

W. H. Donohoe, 17 E. 28th St., New York.
For page see List of Advertisers.

Alex. McConnell, New York.
For page see List of Advertisers.

Robert G. Wilson, Fulton St. and Greene
Ave., Brooklyn, N. Y.
For page see List of Advertisers.

Thomas Young, Jr., 500 Fifth Ave., N. Y.
For page see List of Advertisers.

Young & Nugent, 42 W. 28th St., N. Y.
For page see List of Advertisers

LOBELIAS

Jos. Fuller, 31 Orchard St., Leominster,
Mass.
Carter's Double Blue Lobelia.
For page see List of Advertisers.

NEW AND RARE PLANTS

Road Hill Nurseries, New Rochelle, N. Y.
For page see List of Advertisers.

NICO-FUME

Kentucky Tobacco Product Co.,
Louisville, Ky.
For page see List of Advertisers.

NURSERY STOCK

John Waterer & Sons, Ltd.,
American Nursery, Bagshot, England.
For page see List of Advertisers.

New England Nurseries, Bedford, Mass.
Shrubs, Roses and Herbaceous Perennials.
Specimen Pyramidal Box.
For page see List of Advertisers.

Bay State Nurseries, N. Abington, Mass.
Herbaceous Perennials, Hardy Ornamental
Trees.
For page see List of Advertisers.

Cleary's Horticultural Co., 62 Vesey St.,
New York.
For page see List of Advertisers.

P. Ouwerkerk, 216 Jane St., Weehawken
Helghts, N. J.
Holland Nursery Stock for Forcing.
For page see List of Advertisers

American Nursery Co., 150 Broadway, New
York, N. Y.
For page see List of Advertisers.

Nursery Stock. N. F. McCarthy & Co.,
84 Hawley St., Boston, Mass.

ORCHID PLANTS

Lager & Hurrell, Summit, N. J.
For page see List of Advertisers.

Sander, St. Albans, England,
Importers, Exporters, Growers, Hybridists
For page see List of Advertisers.

Julius Roehrs Co., Rutherford, N. J.
For page see List of Advertisers.

Carrillo & Baldwin, Secaucus, N. J.
For page see List of Advertisers.

Jos. A. Manda, 191 Valley Road, W.
Orange, N. J.
For page see List of Advertisers.

Ordonez Bros., Madison, N. J., Box 105.
For page see List of Advertisers.

PALMS

A. Leuthy & Co., Perkins St. Nurseries
Roslindale, Mass.
For page see List of Advertisers.

Robert Craig Co., Market and 49th St.,
Philadelphia, Pa.
For page see List of Advertisers.

Kentia, Phoenix, etc., all sizes. Write
for new price list. Julius Roehrs Co.,
Rutherford, N. J.

PAINT AND PUTTY

PAINT AND PUTTY: Ideal Greenhouse
lens: Special Greenhouse Putty. Lord &
Burnham, 1133 Broadway, N. Y.

PANSY PLANTS.

Choice pansy plants, 50c. per 100; \$4.00
per 1000. Cash. Aug. Zirnglebel, Need-
ham, Mass.

PATENTS

Siggers & Siggers, Washington, D. C.
For page see List of Advertisers.

PEAT

Orchid peat, Rotted peat, Azalea peat,
Leaf-Mould, Live Sphagnum moss, Baled
Sphagnum moss, Green Clump moss, etc.
Jobbers' list on application. C. W. Brown-
ell & Co., Walden, N. Y.

PELARGONIUMS

R. Vincent, Jr. & Sons Co., White Marsh,
Maryland.
For page see List of Advertisers.

PEONIES

One of the finest collections in America.
Send 25 cts. in stamps for new edition of
Peony Manual. C. S. Harrison's Select
Nursery, York, Neb.

PETUNIAS

Henry A. Dreer, Philadelphia.
Superb Double Petunias.
For page see List of Advertisers.

1500 DOUBLE PETUNIAS from soil,
\$1.25 per 100; \$10.00 per 1000. 2000 Little
Gem Feverfew, \$1.25 per 100; \$10.00 per
1000. E. V. B. Felthousen, 184 Van
Franken Avenue, Schenectady, N. Y.

DLI, Petunias, 8 best market sorts,
named, including a fair proportion of our
new "Camellia-flora," the best white
grown, needs no staking; well rooted,
\$1.25 per 100 prepaid, \$10.00 per 1000;
2-in. short, stocky, \$2.50 per 100. Hopkins
& Hopkins, Chepachet, R. I.

PHLOXES

Send 25 cts. in stamps for Phlox Manual.
Fine mixed phloxes \$1.50 per 100. C. S.
Harrison's Select Nursery, York, Neb.

PIPE AND FITTINGS

Foley Mfg. Co., between Western Ave. and
26th St., Chicago, Ill.

PIPE AND FITTINGS. Cast Iron and
Wrought Pipe, Valves, Elbows, Pipe Hooks,
Automatic Air Headers, etc. Lord &
Burnham, 1133 Broadway, N. Y.

PLANT BED CLOTH

Mineralized Rubber Co., 18 Cliff St., N. Y.
For page see List of Advertisers.

POT HANGERS

Pot hangers, Kramer's \$1 doz. by exp.,
\$1.25 by mail. I. N. Kramer & Son, Cedar
Rapids, Ia.

PRUNING SHEARS

Rhodes Mfg. Co., Grand Rapids, Mich.
Dept. R.

RAFFIA

Raffia (colored), 20 beautiful shades.
Samples free. R. M. Comey Co., Camden,
N. J.; 810 Washburn Ave., Chicago, Ill.

RHODODENDRONS

John Waterer & Sons, Ltd.,
American Nursery, Bagshot, England.
For page see List of Advertisers.

ROSES

Julius Roehrs Co., Rutherford, N. J.
Rambler Rose, Newport Fairy.
For page see List of Advertisers.

New England Nurseries, Inc., Bedford,
Mass.

Roses for Forcing.

For page see List of Advertisers.

Bay State Nurseries, N. Abington, Mass.
Roses for Forcing.

For page see List of Advertisers.

Ellwanger & Barry, Rochester, N. Y.
Hardy Roses.
For page see List of Advertisers.

For List of Advertisers See Page 220

ROSES — Continued

John Cook, 318 Charles St., N. Baltimore, Maryland.
Rose My Maryland.
For page see List of Advertisers.

Charles H. Totty, Madison, N. J. Grafted Stock.
For page see List of Advertisers.

Robert Craig Co., Market and 49th Sts., Philadelphia, Pa.
For page see List of Advertisers.

A. N. Plerson, Cromwell, Conn. Grafted and Own Root Roses.
400 varieties; own roots; summer grown.
Ledlie Company, Springfield, Ohio.

Crimson Ramblers, 2 year, on own roots, extra strong, at 7 cents. Gilbert Costich, Rochester, N. Y.

Low-headed roses, No. 1, \$95.00; No. 11-2, \$65.00 1000. H. T. Jones, Elizabeth, N. J.

SCALECID

B. G. Pratt Co., 11 Broadway, New York.
For page see List of Advertisers.

SEEDS

T. J. Grey Co., 32 So. Market St., Boston, Mass.
For page see List of Advertisers.

Joseph Breck & Sons, 51 and 52 N. Market St., Boston, Mass.
For page see List of Advertisers.

W. Atlee Burpee & Co., Philadelphia.
For page see List of Advertisers.

J. M. Thorburn & Co., 33 Barclay St., N. Y.
For page see List of Advertisers.

A. T. Boddington, 342 W. 14th St., N. Y.
For page see List of Advertisers.

H. F. Michell Co., 1017 Market St., Phila.
For page see List of Advertisers.

James Vick's Sons, Rochester, N. Y. Vick's Snperb Pansy Seed.
For page see List of Advertisers.

Hjalmar Hartmann & Co., 12 Stormgade, Copenhagen, Denmark. Cauliflower and Cabbage Seed.
For page see List of Advertisers.

Rickards Bros., 37 E. 19th St., New York.
For page see List of Advertisers.

R. & J. Farquhar & Co., 6-7 So. Market St., Boston. Giant Cyclamen Seed.
For page see List of Advertisers.

C. C. Morse & Co., 48-56 Jackson St., San Francisco, Cal.
For page see List of Advertisers.

H. E. Fiske Seed Co., Faneuil Hall Sq., Boston.
For page see List of Advertisers.

Braslan Seed Growers Co., San Jose, Cal.
For page see List of Advertisers.

O. V. Zangen, Hoboken, N. J.
For page see List of Advertisers.

R. Wibolt, Nakskov, Denmark. Snowball Cauliflower Seed.
For page see List of Advertisers.

Wm. Elliott & Sons, 201 Fulton St., New York. Lincoln Pansy Seed.
For page see List of Advertisers.

Sander & Son, Bruges, Belgium. Cocos Weddelliana Seed.

Stnupp & Walter Co., 50 Barclay St., New York. Flower Seeds New Crop.
For page see List of Advertisers.

Crego aster seed. Ask for circular. G. S. Crego, Maywood, Ill.

SMILAX

E. A. Beaven, Evergreen, Ala. Southern Wild Smilax; Log Mossea.
For page see List of Advertisers.

SPHAGNUM MOSS

Live Sphagnum moss, orchid peat and orchid baskets always on hand. Lager & Hurrell, Summit, N. I.
Fresh, clean, 5 bbl. bale, \$1.25; 2 bales, \$2.25; 5 bales, \$5.00; 10 bales, \$9.50. Cash. H. R. Akers, Chatsworth, N. J.

STEAM TRAP

E. Hippard, Youngstown, O.
For page see List of Advertisers.

VENTILATING APPARATUS

Pierson U-Bar Co., 1 Madison Sq., N. Y.
For page see List of Advertisers.

Hitchings & Co., 1170 Broadway, N. Y.
For page see List of Advertisers.

Foley Mfg. Co., between Western Ave. and 26th St., Chicago, Ill.
For page see List of Advertisers.

John A. Payne, 260-274 Culver Ave., Jersey City, N. J.
For page see List of Advertisers.

VENTILATING MACHINERY, New Model encased, self-rolling gear; Standard Model Open Gear. Lord & Burham, 1133 Broadway, N. Y.

VIOLETS

William Sim, Cliftondale, Mass. Violet Boston.
For page see List of Advertisers.

Violet cuttings. "Maria Louisa" Rhinebeck stock, rooted runners, May delivery \$20.00 M. Immediate delivery, between now and March 15th, \$10.00 M. Wm. C. Kasting Co., 383 Elliott St., Buffalo, N. Y.

WIREWORK

Reed & Keller, 122 W. 25th St., N. Y.
For page see List of Advertisers.

Wirework. Write for our catalogue. Holton & Hunkel Co., Milwaukee, Wis.

William E. Heilscher's Wire Works, 38-40 Broadway, Detroit, Mich.

The "Just Right" kind. Send for price list. Frank W. Bail, 31 East Third Street, Clucluotl, O.

WHOLESALE FLORISTS

Boston

N. F. McCarthy & Co., 84 Hawley St., Boston.
For page see List of Advertisers.

H. M. Robinson & Co., 15 Province St. and 9 Chapman Pl., Boston.
For page see List of Advertisers.

Welch Bros., 226 Devonshire St., Boston.
For page see List of Advertisers.

Buffalo

Wm. F. Kasting Co., 383-87 Elliott St., Buffalo, N. Y.
For page see List of Advertisers.

Chicago

Chas. W. McKellar, 51 Wabash Ave., Chicago.
For page see List of Advertisers.

Peter Reinberg, 51 Wabash Ave., Chicago.
For page see List of Advertisers.

E. F. Winterson Co., 45-49 Wabash Ave., Chicago.
For page see List of Advertisers.

Detroit

Michigan Cut Flower Exchange, 38 and 40 Broadway, Detroit, Mich.
For page see List of Advertisers.

New York

J. K. Allen, 106 W. 28th St., New York.
For page see List of Advertisers.

J. S. Fenrich, 110 W. 28th St., New York.
For page see List of Advertisers.

Ford Bros., 48 W. 25th St., New York.
For page see List of Advertisers.

H. E. Froment, 57 W. 28th St., New York.
For page see List of Advertisers.

Alex. J. Guttman, 43 W. 28th St., New York.
For page see List of Advertisers.

E. C. Horan, 55 W. 28th St., New York.
For page see List of Advertisers.

WHOLESALE FLORISTS—

New York—Continued

A. H. Laogjahr, 55 W. 28th St., New York.
For page see List of Advertisers.

James McManus, 42 W. 28th St., New York.
For page see List of Advertisers.

John I. Raynor, 49 W. 28th St., New York.
For page see List of Advertisers.

W. F. Sheridan, 39 W. 28th St., New York.
For page see List of Advertisers.

Traendly & Scheock, 44 W. 28th St., New York.
For page see List of Advertisers.

John Young, 51 W. 28th St., New York.
For page see List of Advertisers.

Moore, Heutz & Nash, 55 and 57 W. 26th St., New York.
For page see List of Advertisers.

Frank S. Hieka & Co., 52 W. 28th St., New York.
For page see List of Advertisers.

Frank Millang, 57 W. 26th St., New York.
For page see List of Advertisers.

Chas Millang, 50 W. 29th St., New York.

Wm. H. Kuebler, 28 Willoughby St., Brooklyn, N. Y.
For page see List of Advertisers.

Phillip F. Kessler, 55 and 57 W. 26th St., New York.
For page see List of Advertisers.

A. Moltz, 55-57 W. 26th St., New York.
For page see List of Advertisers.

B. S. Silun, Jr., 55 W. 26th St., New York.
For page see List of Advertisers.

A. L. Young & Co., 54 W. 28th St., New York.

Philadelphia

W. E. McKissick, 1619-1621 Ranstead St., Philadelphia, Pa.
For page see List of Advertisers.

Leo Nissen Co., 1209 Arch St., Philadelphia, Pa.
For page see List of Advertisers.

The S. S. Pennock-Meehan Co., 1608-18 Ludlow St., Philadelphia, Pa.
For page see List of Advertisers.

Edward Reid, 1526 Ranstead St., Philadelphia, Pa.
For page see List of Advertisers.

Pittsburg

J. B. Murdoch & Co., 714 Penn Ave., Pittsburg, Pa.
For page see List of Advertisers.

Providence, R. I.

J. Kopelman & Co., 21 Washington St., Providence, R. I.
For page see List of Advertisers.

San Francisco

Alex. Mann, Jr., Co., 1125 Polk St., San Francisco, Cal.
For page see List of Advertisers.

St. Louis

H. G. Berning, 1402 Pine St., St. Louis, Mo.
For page see List of Advertisers

Washington, D. C.

J. J. Harty & Co., 1312 G. St. N. W., Washington, D. C.
For page see List of Advertisers.

WHOLESALE PLANT MARKETS

Philadelphia Plant Exchange, 839 Market St., Philadelphia.
For page see List of Advertisers.

WHOLESALE PLANTSMAN

Sammel A. Woodrow, 53 W. 30th St., New York.
For page see List of Advertisers.

In writing to Advertisers kindly mention Horticulture

List of Advertisers

New Offers in This Issue.

HELP WANTED

Allen J. K. 214	Leuthy A. & Co. 104
American Nursery ... 106	Lord & Burnham Co. 24
American Nursery Co. ... 106	Lutton W. H. 223
Aschmann Godfrey ... 194	Manda Jos. A. 209
Atlanta Floral Co. 24	Mann, Alex. Jr. Co. 215
Bambrick Thos. H. 220	McCarthy N. F. & Co. 215
Barrows H. H. & Son ... 104	McCannell Alex. 211
Baur Floral Co. 104	McKellar Charles W. 212
Bayersdorfer H. & Co. 212	McKissick, W. E. 212
Bay State Nurseries ... 106	McMann Jas. 214
Beaven E. A. 210	Metropolitan Ma- terial Co. 223
Berning H. G. 213	Michell H. F. Co. 206
Boddington A. T. 07	Michigan Cut Flower Exchange. 215
Boston Florist Letter Co. 210	Millang Frank. 215
Boston Plate and Win- dow Glass Co. 22	Mineralized Rubber Co. 223
Bosch, Felix. 226	Moltz, A. 215
Braslan Seed Growers Co. 207	Moninger J. C. 223
Breck Joseph & Sons ... 207	Moore, Hentz & Nash ... 215
Brettmeyer's J. Sons ... 214	Moore, J. L. 194
Bridgeman's Seed Warehouse. 207	Morse C. C. & Co. 207
Burpee W. A. & Co. 207	Murdoch J. B. & Co. 213
Carrillo & Baldwin ... 209	Murray Samuel 211
Cassidy J. 223	New England Nur- series 196
Champion J. N. & Co. 211	Niessen Leo. Co. 194
Chicago Carnation Co. 194	Ordonez Bros. 209
Clarke's David, Sons ... 211	Onwerkerk P. 196
Cleary's Horticultural Co. 215	Paethorpe P. R. Co. 222
Coard & Jones Co. 194	Park Floral Co. 211
Cook John 196	Payne John A. 222
Cooke G. H. 211	Pennock-Meehan Co. 212
Cowee A. 206	Perkins St Nurseries. 104
Craig, Robt. Co. 194	Pierson, A. N. 195
Doane Geo. B. & Son ... 222	Pierson F. R. Co. 195
Donohoe W. H. 211	Pierson U Bar Co. 224
Dorner F. Sons & Co. 195	Pratt B. G. Co. 220
Dreer H. A. 209-213	Pulverized Maure Co. 222
Dysart R. J. 213	Raynor John L. 214
Edgar, W. W. Co. 212	Reed & Keller. 215
Edwards Folding Box Co. 212	Reid Edw. 212
Elliott Wm. & Sons ... 207	Reinberg Peter. 212
Ellwanger & Barry ... 196	Rickards Bros. 207
Esler J. G. 222	Robinson H. M. & Co. 215
Ernest W. H. 222	Rock Wm. L. Flo. Co. 211
Eyres 211	Rochrs Julius Co. 196-209
Farquhar R. & J. & Co. 207	Rolker August & Sons 194-222
Ferlich J. S. 214	Rose Hill Nurseries. 196
Fiske, H. E. Seed Co. 07	Ruscioni D. 209
Ford Mfg. Co. 223	Sander & Soo. 209
Ford Bros. 214	Schulz Jacob. 211
Froment H. E. 214	Scott, John. 194
Fuller J. 194	Sheridan W. F. 214
Galvin Thos. F. 211	Siggers & Siggers. 223
Garnsey M. V. 210	Sim. Wm. 194
Grey T. J. Co. 207	Situations & Waots. 220
Gude Bros. Co. 211	Skidelsky S. S. 195
Gutman Alex. J. 214	Slinn B. S. Jr. 214
Haerens A. 194	Smyth Wm. J. 211
Hall Assn. 222	Standard Plate Glass Co. 223
Haines, J. E. 195	Stearns A. T. Lumber Co. 223
Hartmann Hjalmar & Co. 207	Stewart, E. E. 209
Hary, Jas. J. & Co. 212	Stump & Walter Co. 104-207
Hauswirth P. J. & J. E. 211	Thorburn J. M. & Co. 207
Herbert David & Sons ... 194	Totty Chas. H. 195
Hews A. H. & Co. 212	Traendly & Schenck. 214
Hicks Frank S. & Co. 215	Valentine, J. A. 211
Hilfinger Bros. 222	Velthuis K. 206
Hippard E. 222	Vick's Jas. Sons 207
Hutchings & Co. 224	Vincent R. Jr. & Sons. 194
Hoffman 211	Waterer John & Sons. 196
Horan E. C. 214	Weber F. C. 211
Houghton & Clark. 211	Weber H. & Sons. 195
Jahn, H. A. 195	Welch Bros. 212
Kasting W. F. 215	Wiboltz, R. 207
Kentucky Tobacco Product Co. 222	Wilson. 213
Kervan Co., The. 113	Winterson, E. F. Co. 212
Kessler, P. F. 14	Woodrow, Sam'l A. 215
Kimberly Frank H. 195	Yokohama Nursery Co. 193
King Cons. Co. 223	Young John 214
Kouelman J. & Co. 13	Young, Thos. Jr. 211
Koral Mfg. Co. 210	Young & Nugent ... 211
Kramer Bros. Fdy Co. 220	Zanten O.V. 207
Kuebler Wm. H. 215	Zinn, J. A. 213
Lager & Hurrell 206	? 208
Langjahr, Alfred H. 214	

CANNA ROOTS.
Stump & Walter Co., 50 Barclay St.,
New York, N. Y.
For page see List of Advertisers.

GLADIOLI.
E. E. Stewart, Rives Junction, Mich.
For page see List of Advertisers.

SEEDS.
Weber & Don, 114 Chambers St.,
New York.
For page see List of Advertisers.

SPECIMEN EVERGREENS.
The New England Nurseries, Bedford,
Mass.
For page see List of Advertisers.

THE AMERICAN ROSE SHOW IN CHICAGO.

In addition to what are already pub-
lished the following prizes have been
sent in for the exhibition in March:

Kroeschell Bros. Co., Chicago, \$10
in gold for the best vase of 50 blooms
of Killarney; \$10 in gold for largest
exhibit of Hybrid Perpetual roses in
pots. Vaughan's Seed Store, cup, value
\$25, will announce later what for.
Weiland & Olinger, \$10 for 50 Chate-
nay. H. N. Bruns, Chicago, \$10 pre-
mium, Society to choose class. Poehl-
mann Bros. Co., \$50 cash for best 100
pink roses and \$50 for best 50 red
roses (Beauty and Richmond ex-
cluded). Frederick C. Newbold, offers
a cash prize of \$10 for the best display
of white roses. Emil Buettner, Park
Ridge, Ill., cash prize \$25.

We have this from the Chicago Flor-
ists' Club: Be assured that you will
find our Chicago boys will be on hand
in good style for the Rose Show, but
we want you to make an effort earnest-
ly and vigorously to get pledges of
attendance and exhibits from every
leading grower east of the Allegheny
Mountains. Chicago will take care of
the rest. Now men of the east, do you
hear the call? What shall the answer
be. We are coming. O! Chicago! with
our "Jardines" and our "Smiths,"
"Wyndmoor," "Beatrice" and hosts
more beside, "Simpson and his Rich-
monds," "Burton and his Beauties,"
"Elliot and his Killarneys," "Pare-
wald with his Liberty."

New Jersey sends the answer "Dinna
ye hear the Slogan! the Campbells are
all coming."

All intending exhibitors are request-
ed to send word to the secretary.

BENJAMIN HAMMOND,
Sec. Amer. Rose Society.

NEWS NOTES.

E. B. Hutchins is proprietor of the
New Floral Co., Bangor, Me.

A. F. J. Baur and Mr. and Mrs. John
Bertermann have returned to Indian-
apolis from the Carnation convention.
Preparations are already begun in that
city for the meeting of the carnation-
ists in 1909. The Indianapolis florists
will visit the Richmond florists on
February 15, and it is hoped a strong
delegation will turn out as it is sug-
gested that the Quaker brothers have
something interesting to communicate.

WANTED — SALESMAN

To Handle Good Side Line
On Commission

One who calls on Florists, Seed
Houses, Nurseries, Cemetery Superin-
tendents, Monument Dealers, etc.

The Kramer Bros. Foundry Co.
DAYTON, OHIO

WANTED—Young man with some ex-
perience in Orchid growing, \$30 per
month with board and lodging. Refer-
ence wanted. A. Perleat, Collingdale, Del.
Co., Pa.

HORTICULTURE needs a wideawake
representative in every town in the land.
Good commissions paid on advertising and
subscriptions. If you are ambitious, write
for terms.

SITUATIONS WANTED

GOOD MEN

When you need good men,
skilled or unskilled, Write:

THOS. H.
BAMBRICK

34 South 7th Street Philadelphia

Help of all kinds, including that for
Florists, Nurserymen, Seedsmen and the
Horticultural trade generally.

SITUATION WANTED—By German
gardener and florist, married, 30 years of
age, 16-years' experience in landscape gar-
dening and greenhouse cultivation, wishes
position as foreman on first-class private
or commercial place; good references.
Julius Bauer, Fernbrook, Bordentown, N. J.

SITUATION WANTED—German florist,
25 years of age, two years in this country,
wants position in general greenhouse work.
10 years' experience. Authoine Moser,
care Jos. Schluidermann, 402 E. 89th St.,
New York City.

WANTED—Position as private gardener
or in commercial place, 25 years' all-
round experience. Good references. Ad-
dress, R. T., care HORTICULTURE.

SITUATION WANTED in general green-
house work; single, age 35, five years' ex-
perience, commercial. Address W. W., care
HORTICULTURE.

MISCELLANEOUS WANTS

WANTED—To buy, to lease with the
right to buy, or to lease, several Green-
houses with ground where retelling and
landscaping is possible. Address L. L.,
care of HORTICULTURE.

FOR SALE

FOR SALE—Ten acres of fine soil for
roses and carnations; five greenhouses
recently built, heated with steam, boiler
capable to heat three times as much glass.
The houses are stocked with roses and
adiantums. Excellent railway facilities;
22 miles from Philadelphia. Price, \$4,500.
Possession immediately or April 1. Ad-
dress P. O. Box 77, North Wales, Pa.

FOR SALE—A large consignment of 16x24
double thick American glass, A and B
quality. For further information write
Parsbelsky Brothers, 59 Montrose Avenue,
Brooklyn, N. Y.

EXCHANGE

FOR EXCHANGE—First class Calla
lilbs, one and two years old, for R. C.
Carnations or Geraniums. W. J. Kings-
bury, Derry, N. H.

Is Your Name In The Above
List? If Not, Why Not?

Obituary

J. B. Heiss.

News of the death of this leading florist of Dayton, O., on Friday, January 31, reached us too late for publication in our issue of last week. To us as to a host of other devoted friends it came as a great and very sad shock. Ever since his return from Europe last fall, Mr. Heiss has been suffering intermittently from rheumatism, but was apparently quite well when he started on Tuesday on a visit to relatives at Bethel. He was taken ill on the train and grew steadily worse until Friday, when the end came.

Mr. Heiss was in his 54th year. He was born in Frankfort, Germany, and came to Dayton some twenty-five years ago. He was florist at the Dayton state hospital for a number of years, and some twenty years ago entered the florist trade, and from a small beginning built up a fine business.

Eighteen years ago he married Miss



J. B. HEISS

Clara Ruchhaber of Dayton, who survives him. Mr. Heiss was a member of the Society of American Florists and served as state vice-president for Southern Ohio last year. As president of the Dayton Florists' Club at the time of the visit of the National Society to Dayton he rendered conspicuous service and the success of the convention was due in no small degree to his earnest, persistent, untiring zeal and industry in the preparatory work and during the stay of the visitors in his city, many of whom will never forget his free-hearted hospitality.

"Friend after friend departs;
Who hath not lost a friend?
There is no union here of hearts
Which hath not here an end."

William J. Allan.

William J. Allan, only son of William Allan, gardener to Dr. Jacobs, and himself an assistant to John T. Allan at the Drexel estate, Newport, R. I., passed away as a result of an illness caused by appendicitis on Feb. 4. William J. Allan was a deservedly popular young man and a bright future seemed in prospect for him. His tak-



"SCALECIDE"





HAS MADE SPRAYING EASY THEN WHY NEGLECT YOUR TREES?

The N. Y. Herald, November 17, '07, says: "The chances are about a hundred to one that you have the San Jose Scale on your place and do not know it," and advises the use of "SCALECIDE." This is good advice. "SCALECIDE" has been tested and tried, and found thoroughly effective. The same yesterday, to-day, and all the time. One gallon makes 15 to 20, ready to use, by simply adding water.

Prices: 1 gal., \$1.00; 5 gal., \$3.25; 10 gal., 6.00; 50 gal. bbl., \$25.00, F. O. B. our factory. Order to-day. Write for booklet Wand free sample.

B. G. PRATT CO., Mfg. Chemists,
11 Broadway, New York City.

ing away in the full vigor of budding manhood, where in his own home life and in the affectionate regard of everyone who knew him all was brightness, has cast a shadow dark and lingering. Much genuine sympathy is expressed for his young widow and his father and mother and sister. He was only 24 years of age. D. M.

Numa Reid Cook.

Numa Reid Cook, born June 25, 1878, died at the home of his sister, Mrs. G. S. Boren, Pomona, N. C., January 29, 1908. Mr. Cook's first experience in the growing of cut flowers was with the J. Van Lindley Nursery Co. of Pomona. He afterwards held positions with florists in New England, Norfolk, Va., Chester, Pa., and latterly with the Green Floral & Nursery Co. of Dallas, Texas. He was a young man of honor and ability and much loved by all.

Charles Flunker of Tennessee Avenue, St. Louis, Mo., passed away recently at the age of 73.

Nicholas B. Rowley, florist, of Corn- ing, N. Y., died on February 4. A brother and a sister survive him.

Charles G. Endlich, who for several years was gardener on various private estates in Brattleboro, Vt., died on February 1, aged 64.

Thompson C. Maxwell, a prominent nurseryman of Geneva, N. Y., died on February 3, aged 86. A widow and two daughters survive him.

George R. Paine of Baldwinville, Mass., one of the large growers of hot-house cucumbers in Central Massachusetts, died on February 3 at the age of 67.

James W. Pinchot, father of Gifford Pinchot, chief forester of the government, died in Washington, D. C., on February 10. He was born in Milford, Pa., in 1831.

Patrick Arnold, for many years a florist in Greenwich, Conn., died in that city on February 6, aged 81. He was a trusted employe of "Boss" Tweed for many years.

William Anderson, 74 years of age, for the past twenty years gardener for Mrs. Lewis Tompkins, Fishkill Land- ing, N. Y., died on February 1. A widow and five children survive him.

Harry E. Hobday, an Englishman 25 years old, employed at Budlong's greenhouse establishment, Cranston, R. I., was instantly killed on February 7 while crossing the railroad tracks on his way to work. He leaves a wife and two children.

NEWS NOTES.

J. F. Nellest, Grand Rapids, Mich., who has made a success of raising early vegetables, will add the culture of flowers to his other industries.

W. E. K. Johnson, florist, Allentown, Pa., recently deceased, left his estate valued at \$40,000 to home and foreign missions after the death of his wife.

John Allanach, recently in charge of the Converse estate, Marion, Mass., has purchased the Vose property in that town and will take up landscape gardening and raise flowers for the market.

At the rooms of the American Insti- tute, New York City, on February 12, Dr. E. M. East of the Connecticut Ex- periment Station led in the discussion on the improvement of plants by sporting.

Preparations for the flower show at Los Angeles, Cal., the week of April 6, are going forward on an elaborate scale. George Hand, Dr. A. D. Hough- ton and Fred Gates have the matter in charge.

The park commission of Brockton, Mass., have recommended an expendi- ture of \$35,000 for the coming year; that \$25,000 be expended on Salisbury park; that Keich park be accepted and \$5,000 be spent there and \$5,000 on Perkins park.

The Syracuse (N. Y.) Herald an- nounces that Henry Youell, superin- tendent of The Herald Gardening Club, will gladly give a practical talk on plants and flowers to any school in the evening. His address is 111 Lexington avenue, Syracuse, N. Y.

The Grand Rapids Greenhouse Co. has just been formed at Grand Rapids, Mich., and combines the interests of F. M. Strong, S. J. Perry, E. E. Taylor and Frank Cook, who are among the leading vegetable raisers in that place. In order to provide for additional greenhouses \$165,000 of preferred stock is offered for sale. S. J. Perry is the general manager.

Mrs. Jeannette M. Gilbert of Clay- ville, N. Y., has presented the Utica Public Library with the extensive and valuable collection of ferns which was the property of her late husband, Ben- jamin B. Gilbert. The collection of the late James Constable, which had passed into the possession of Mr. Gil- bert, has also been given to the Utica Library through the suggestion of Mrs. Constable. Mr. Gilbert was an authority on ferns and a frequent con- tributor to botanical publications.

Tobacco Paper "NICO-FUME" **LIQUID**
 IS THE **STRONGEST,**
BEST PACKED,
EASIEST APPLIED. **OVER 40% NICOTINE**
By far the
CHEAPEST.
Furnishes the
Most Nicotine for the Money! **JUST NOTE PRICES!**

24 sheets.....\$ 0.75	Pint.....\$ 1.50
144 sheets..... 3.50	½ Gallon..... 5.50
288 sheets..... 6.50	Gallon..... 10.50
1728 sheets..... 35.10	5 Gallons..... 47.25

... Manufactured by ...
THE KENTUCKY TOBACCO PRODUCT CO., **Louisville, Ky.**

GREENHOUSES BUILDING OR CONTEMPLATED.

- Marion, Mass.—John Allanach, one house.
- St. Louis, Mich.—Kleinhaus Bros., one house.
- Pitchburg, Mass.—Wm. H. Ritter, one house.
- Melrose, Mass.—Cornelius Casey, house 32x150.
- Springfield, O.—Leedle Rosary Co., range of houses.
- Milwaukee, Wis.—H. W. Koerner, range of houses.
- Mt. Ephraim, N. J.—A. Browning, vegetable house, 30x100.
- Grand Rapids, Mich.—Grand Rapids Greenhouse Co., range of houses.

LIST OF PATENTS.

Issued January 28, 1908.

- 877,515. Vegetation Destroyer. William R. McKeen, Jr., Omaha, Nebr., and Frank S. Barks, St. Louis, Mo., assignors to Railroad Weed Burner Co., St. Louis, Mo., a corporation of Delaware.
- 877,551. Automatic Sprinkler Head. Emanuel M. Cook, Indianapolis, Ind.
- 877,652. Attachment for Mowing Machines. Frank S. Laffin, Sears, Ill.
- 877,707. Automatic Sprinkler System. James Fiddes and John F. Watt, Aberdeen, Scotland, assignors to the Expansion Sprinkler Syndicate, Limited, Aberdeen, Scotland.
- 877,712. Fertilizer Distributer. Rudolph P. Hassler, Luverne, Minn.



The FLORISTS' HALL ASSOCIATION OF AMERICA, insurer of 28,000,000 sq. ft. of glass. For particulars address John C. Esler, Sec'y, Saddle River, N.J.

THE STANDARD STEAM TRAP

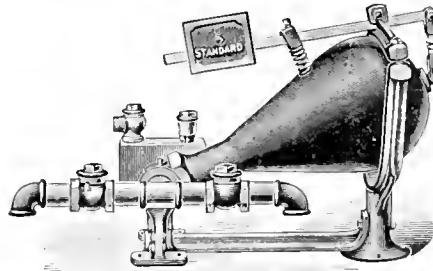

Is acknowledged the best for the florist, because it is durable and does its work without trouble and annoyance; saving its cost by the economy in coal bills.

E. HIPPARD
 YOUNGSTOWN, OHIO



I MANUFACTURE AND ERECT

Iron frame and wood Greenhouses of every type for commercial and private use. If you contemplate building, allow me to submit sketch and estimate covering your requirements.

JOHN A. PAYNE,
 Horticultural Architect and Builder.

Main Office and Factory:
 260-274 Culver Ave., Jersey City, N.J.
 Sash opening apparatus and all kinds of greenhouse structural material.

IRON PIPE

SECOND HAND

WROUGHT IRON PIPE, for Steam, Water, Gas or Oil, Fences or Posts. All Sizes. Price Low.

GEO. B. DOANE & SON
 18 Midway Street, BOSTON
 Telephone, Main 4419

BOSTON PLATE & WINDOW GLASS CO.

GREENHOUSE GLASS
 German and American

261 to 287 A St., BOSTON 20-22 Canal St.



The Best Bug Killer and Bloom Saver

For PROOF Write to

P. R. Palethorpe Co.
 OWENSBORO, KY.

STANDARD FLOWER POTS

Packed in small crates, easy to handle.			
Price per crate		Price per crate	
1500 2 in. pots in crate \$4.88		120 7 in. pots in crate \$4.20	
1500 2 1/4 " " " 5.25		60 8 " " " 3.00	
1500 3 " " " 6.00		HAND MADE	
1000 3 " " " 5.00		48 9 in. pots in crate \$3.60	
800 3 1/2 " " " 5.80		48 10 " " " 4.80	
500 4 " " " 4.50		24 11 " " " 3.60	
320 5 " " " 4.51		24 12 " " " 4.80	
144 6 " " " 3.16		12 14 " " " 4.80	
		6 16 " " " 4.50	

Seed pans, same price as pots. Send for price list of Cylinders for Cut flowers, Hanging Baskets, Lawn Vases, etc. Ten per cent. off for cash with order. Address Hlffinger Bros., Pottery, Fort Edward, N.Y. August Rolker & Sons, Agts., 31 Barclay St., N. Y. City.

Standard Flower . . POTS

If your greenhouses are within 500 miles of the Capitol, write us, we can save you money

W. H. ERNEST,
 28th and M Street WASHINGTON D. C.



Cattle Manure In Bags Shredded or Pulverized

Best and safest manure for florists and greenhouse use, absolutely pure, no waste, no danger. Write for circulars and prices.

The Pulverized Manure Co., 31 Union Stock Yards, Chicago

WILLIAM H. LUTTON

HORTICULTURAL ARCHITECT AND BUILDER

WEST SIDE AVENUE STATION (C. R. R. OF N. J.)
JERSEY CITY, N. J.

Have not been established 50 years, but long enough to convince the wide-awake Florist and Gardener that it is to his interest to place his work in thoroughly practical hands.

(150,000 sq. ft. glass erected in 1907 will substantiate this claim.)

And why not? My material is the best that can be secured. My iron frame construction has every modern feature that years of practical experience can embody.

AND THEN THERE IS THE COST TO BE CONSIDERED.

Why not let us take up this important question now?

GREENHOUSE GLASS

Cheaper Now Than For Years

We are taking contracts for next Spring delivery.

WRITE FOR OUR PRICES

STANDARD PLATE GLASS COMPANY

26-30 Sudbury St. 61-63 Portland St.
 BOSTON, MASS.

CYPRESS SASH BARS
 82 feet or longer
HOT BED SASH
PECKY CYPRESS BENCH LUMBER

GREENHOUSES

ERECTED AND EQUIPPED COMPLETE IF DESIRED

Write for Circular "D" and Prices

The A. T. STEARNS LUMBER CO.
 NEPONSET, BOSTON, MASS.

METROPOLITAN MATERIAL CO.
 GREENHOUSE WRECKERS

GLASS Look at these prices. New American 50 ft. to the box, 10x12 single \$1.80 per box, 10x12, 12x12 B. double \$2.30 per box, 12x14, 12x20 and 14x14, 14x20 and 16x16, 16x18 B. double \$2.50 per box, 16x20, 16x24, 12x24 B. double \$2.65 per box. In lots of 10 boxes or more. Let us quote you on

CYPRESS MATERIAL HOTBED SASH BOILERS PIPE FITTINGS HOTBED FRAMES PATS

1398-1408 METROPOLITAN AV., BROOKLYN, N. Y.

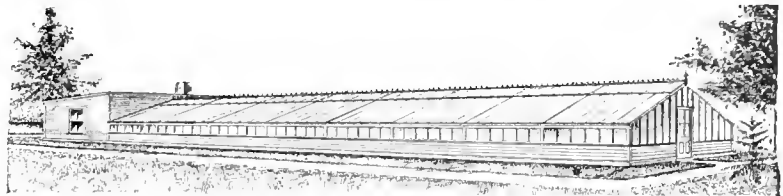

GREENHOUSE MATERIAL

Furnished and Erected. Write for Prices

I. CASSIDY, SUMMER AVENUE AND ERIE R. R. **Newark, N. J.**

NOW IS THE RIGHT TIME TO FIGURE **MATERIAL** AND PLAN FOR THE BUILDINGS OF THIS YEAR

FOLEY'S } QUALITY AND WORK THE BEST.
 PRICES RIGHT AND LOWEST.
 ESTIMATES WILL PROVE. TRY US.

Foley Ventilating Apparatus Unequaled

Will Ventilate any Size of House Easily. Send for Circular.

THE FOLEY MFG. CO. Western Ave. 25th & 26th Sts. **CHICAGO**

ANCHOR GREENHOUSE HOSE

WEARS WELL.

PLANT BED CLOTH

Protects from Cold and Dampness.

MINERALIZED RUBBER CO.

18 Cliff Street New York

GREENHOUSE CONSTRUCTION LUMBER

John C. Moninger Co.
 117 E. Blackhawk St., CHICAGO

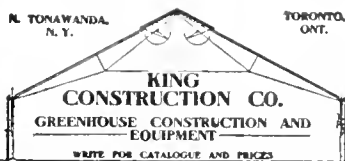

N. TONAWANDA, N. Y.

TORONTO, ONT.

PATENTS

Trademarks and Copyrights

Send your business direct to Washington. Saves time and insures better service. Personal attention guaranteed. Twenty-five years' active service. SPECIALTY: "Working on the Failures of Others."

SIGGERS & SIGGERS

PATENT LAWYERS

Box 9, National Union Building
 Washington, D. C.

Holds Glass Firmly FULL SIZE N° 2

See the Point of PEERLESS

Glazing Potatoes are the best. No rights or lefts. For a 1,000 points 15 cts postpaid.

HENRY A. DEERE
 714 Chestnut St. Phila. Pa.

In ordering goods please add, "I saw it in HORTICULTURE"

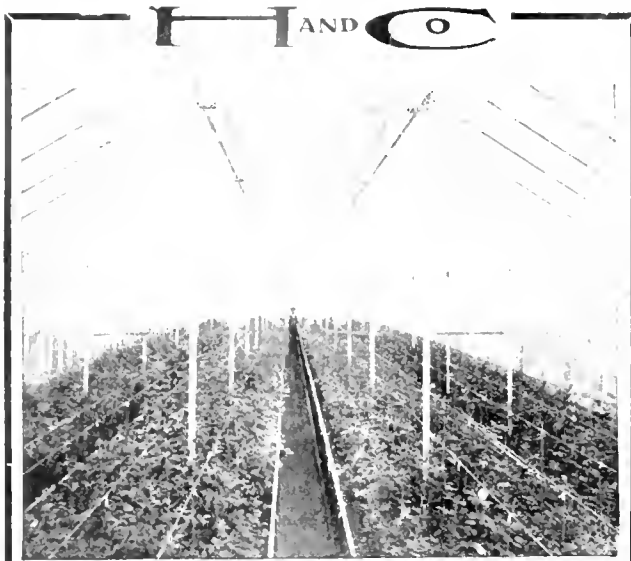

Our System of
**CLAMPED COLUMN SUPPORTS, GIVES
 TO THE HALF IRON FRAME
 GREENHOUSES
 GREAT RIGIDITY AND ENDURANCE**

Before You Build
 Write Us

HITCHINGS & CO.

1170 Broadway
 NEW YORK



THE GIANT CLAMP

This is the clamp used in making the Giant Arch, and is responsible for the rigidity of the entire pipe frame in our Semi-Iron house. For rigidity and lightness, the framing made with this Giant Clamp of ours, has been described as a "tower of strength." Send for descriptive circular.

WE MAKE EVERY PART OF A GREENHOUSE
 INCLUDING THE GLASS. WE SELL ANY PART.

LORD & BURNHAM CO.

1133 BROADWAY, cor. 26th Street, N. Y.
 BOSTON Branch: 819 Tremont Building
 PHILADELPHIA Branch: 1215 Filbert St.



Then there is the downright practical side of U-Bar houses, the side that means more flowers, or vegetables of finer quality with less care and expense than in any other houses constructed any other way. The reason for this is, in short—*more light*. You see there is no gutter at the eave—no heavy members—the glass is spaced 24 inches instead of 16 inches. Every structural detail has been reduced to the smallest possible point. Still with all this extreme lightness of construction, there is not a more rigid, enduring house made—and it is the U-Bar that does it. The catalog although filled with U-Bar houses, both exteriors and interiors, also shows plans, sections and all the interesting structural details that you like so well to know—Send for it. **Pierson U-Bar Company**, Designers and Builders *U-Bar Greenhouses*, Metropolitan Building, 4th Avenue and 23rd Street, New York.



HORTICULTURE

Vol. VII. FEBRUARY 22, 1908 No. 8



JAMAICAWAY. OLINSTED PARK, BOSTON, MASS.

Devoted to the
**FLORIST, PLANTSMAN,
LANDSCAPE GARDENER,**
and
Kindred Interests

Published
EVERY SATURDAY
At 11 Hamilton Place,
BOSTON, MASS.
Subscription, \$1.00

FEB 24 1908

CANNA BULBS

Fine plump, Northern Grown, and in fine condition. Not to be compared with Southern grown stock, that are never thoroughly ripened and therefore are very slow to start growing.

	Doz.	100	1000		Doz.	100	1000
Allemania	\$0.35	\$2.50	\$22.50	Gladiator	\$0.40	\$3.00	\$27.00
Black Prince	.40	3.00	27.00	King Edward	.50	3.50	32.00
Black Warrior	.35	2.50	22.50	Louisiana	.55	4.00	35.00
Burbank	.30	2.25	20.00	Mad. Crozy	.40	3.00	27.00
Black Musafolia	.40	3.00	27.00	Mile. Berat	.30	2.25	20.00
Charles Henderson	.35	2.50	22.50	Musafolia	.30	2.25	20.00
Director Roelz	.35	2.50	22.50	Paul Marquant	.30	2.25	20.00
Flamingo	.30	2.25	20.00	Pres. McKinley	.35	2.50	22.50
Florence Vaughan	.35	2.50	22.50	Queen Charlotte	.35	2.50	22.50
Golden Star	.30	2.25	20.00	Robusta	.30	2.00	18.00
				Red Cross	.30	2.25	20.00

STUMPP & WALTER CO., 50 Barclay St., NEW YORK

GERANIUMS.

Our New Illustrated Catalogue Mailed to the Trade. An immense stock of plants in 2 in. pots ready for immediate shipment \$2.00 per 100; up to \$1.00 each. Our selection of 20 good varieties, \$18.50 per 1000. New Varieties 125-150 introduction, one each of 10 kinds, \$5.00. 1007 Novelties, Bruants, Cannells, Bouchardlet and Lemoine introduction, one each of 10 kinds \$10.00.

	Per 100	Per 1000
Pelargoniums, Strong plants 2 in pots - Ivy Leaved Geraniums Six good varieties. \$2.50 per 100, 3.00	\$6.00	\$2.00
Dahlia Roots, 150 varieties whole field clumps	5.00	2.00
Hardy Chrysanthemums, 75 varieties	2.00-3.00	2.00
Alyssum, Giant Double	2.00	2.00
Cuphaea, Giant Plant	2.00	2.00
Coleus, Verschaffeltii, Golden Peddler and other kinds	2.00	1.00
Fuchsias, Black Prince and Minnesota - Lieutenant Muritz, White and Rose Phenomenal	2.50	3.00

Hardy English Ivy, Extra Strong, \$15.00 per 1000 \$2.00
 Hollyhocks, Strong 2 in. pot plants, dbl. white, pink, red and yellow 3.00
 Lobelia, Crystal Palace Gem 2.00
 Panicum, Variegated, Handsome basket plants 2.00
 Tradescantia, Dark Variegated 2.00
 Verbena, Red, White, Purple and Pink 2.00
 Caladium, Esculentum, 1st size \$2.00 per 100 and size 1.00
 Lavender, 2 1/2 in. pots strong 3.00
 Swainsona, Alba 2.00

R. Vincent Jr. & Sons Company, White Marsh, Md.

NEW—A MONEY MAKER—NEW CARTER'S DOUBLE BLUE LOBELIA

2 in. pots, \$1.00 per 100; \$7.00 per 1000

CASH WITH ORDER PLEASE. **J. FULLER, 31 Orchard St., LEOMINSTER, MASS.**

CANNAS

Send for our List and Prices

The CONARD & JONES CO. WEST GROVE, PA.

NEPHROLEPIS SCOTTII

in the following sizes, extra good value
25c., 50c., 75c., and \$1
Grand Specimen Plants at \$3, \$4, \$5, \$6.

JOHN SCOTT
Rutland Road and E. 45th St.
Tel. 280 Bedford **BROOKLYN, N. Y.**

AZALEAS FOR FALL DELIVERY

The best that are grown, also **Palms** for Spring or Fall delivery furnished by **AUGUST HAERENS**, Somergem, Belgium. Orders booked now. Address the American representatives.

AUGUST ROLKER & SONS, New York
34 Barclay Street or P. O. Box 752

GODFREY ASCHMANN

Importer and Wholesale Grower and Shipper
of Araucaria Excelsa, Compacta, Kolusta and Glauca; Kentia Forsteriana and Belmoreana Azalea, Indira, etc. Cultivator of Boston, Scottii, Barrowsii, Elegantissima and Whitmanni Ferns. Ferns for dishes, Cocos, etc. Write for prices.
1012 Ontario St., Philadelphia

Just Received in Splendid Condition

15,000 AZALEAS

in all sizes and varieties

25c. up to \$2.00 each

Also Kentias, Rubbers, Araucarias, Pandanus, Boxwood, Euonymus, Crotons, Areca and Eurya latifolia.

Extra good value in large Specimen and Decorative Palms
A. LEUTHY & CO.

Perkins Street Nurseries, Rosindale, Mass.

NEP. WHITMANI

2 1/4 in., \$5.00 per 100

NEP. WHITMANI

3 1/2 in., \$25.00 per 100

BOSTON FERNS

2 1/4 in., \$3.00 per 100

H. H. BARROWS & SON Whitman, Mass.

FERNS

Boston, 4 inch 12c, 5 inch 25c.
Pierisii, 3 inch 8c.
Elegantissima, 2 1/4 inch 6c, 3 inch 10c,
4 inch, 15c.

BAUR FLORAL CO., Erie, Pa.

Rooted Carnation Cuttings

	100	1000
Pink		
Aristocrat	\$6.00	\$50.00
Winsor	6.00	50.00
Rose Pink Enchantress	3.50	30.00
Enchantress	3.00	25.00
Lawson	2.50	20.00
Joost	2.00	15.00
White		
White Perfection	3.00	25.00
" Lawson	3.00	25.00
Queen	2.00	18.00
Boston Market	2.00	18.00
Louise	2.00	18.00
Lt. Peary	3.00	25.00
Bountiful	2.50	20.00
Red		
Beacon	6.00	50.00
Victory	3.00	25.00
Robert Craig	3.00	25.00
Flamingo	2.50	20.00

Miscellaneous

Patten	2.50	20.00
Harry Fenn	2.50	20.00
Harlowarden	2.50	20.00

Stock Guaranteed—Prompt Deliveries

THE LEO NIESSEN CO.

WHOLESALE FLORISTS

1209 Arch St., PHILADELPHIA

Winsor and White Enchantress

Two of the greatest Carnations on earth. No order too large, no order too small. Absolute satisfaction guaranteed. Immediate delivery.

\$6.00 per 100	\$50.00 per 1000 from sand,
\$7.50 " 100	\$60.00 " 1000 from soil,
\$9.00 " 100	\$75.00 " 1000 from pots.

Try Us

WHITE BROS., GASPOT, N. Y.

Herbaceous Perennials

A complete stock of the most desirable of the standard varieties.

RED OAK NURSERIES WISKEVILLE, R. I.

ROBERT CRAIG CO.

ROSES, PALMS,

and Novelty in Decorative Plants

MARKET and 49th STREETS., PHILADELPHIA, PA.

100,000 DAHLIAS

Premium Stock, guaranteed true to name. 500,000 large Flowering Gladioli, hundreds of colors and variations mixed. Wholesale prices on application. Order now for spring delivery. Catalogue free.

J. L. MOORE, Northboro, Mass.
Now is the time to place your order for bulbs which will insure you getting named varieties in any quantity; prompt delivery.

DAHLIAS.

DAVID HERBERT & SON,
Successors to L. K. Peacock, Inc.
ATCO, N. J.

NEW "My Maryland" ROSE

Best up-to-date commercial rose; read what others have to say about it.

The Gardeners' and Florists' Club of Boston:—A Report of Merit is Hereby Awarded to JOHN COOK For Vase New H. T. Rose No. 294 since named "MY MARYLAND."

Description and points of particular merit: This New Rose has a pleasing shade of Salmon pink. With other essential characteristics of a good commercial Rose fully proven, much may be expected of it. The Committee believes this variety will be especially valuable in the Light Pink Class of Winter blooming roses. Given by the Gardeners' and Florists' Club of Boston this 17th day of December, 1907.

SIGNED: W. N. CRAIG, Secy.

Price 2 and 2½ inch pots, \$25 per 100; \$200 per 1000. Price 3 inch pots, \$5 per dozen.

JOHN COOK, 318 North Charles St. Baltimore, Md.

CARNATION CUTTINGS

We are in unusually good position to supply exceptionally well-rooted, healthy stock. We have such a large quantity of flowering plants that we propagate only from heel cuttings from flowering shoots. Our cuttings are rooted in light, sunny, airy houses, and we are sure will satisfy the most critical buyer. A prominent carnation grower writes, "You seem to be the only firm in the business that knows how to pack stock and have it reach the buyer in good condition, and I have always found your cuttings cheaper than the same varieties from others at much lower figures." While our prices may not always be the cheapest, we certainly can give, quality considered, as good value as, if not better than, is obtainable anywhere.

WINSOR which we introduced last year has proved to be the finest novelty introduced in years. We think it is the most profitable variety grown today, considering its fine color, splendid keeping qualities, and productiveness. When properly grown, it leaves little to be desired, and almost every one succeeds with it.

WHITE ENCHANTRESS the best all-round white carnation, on account of its large size, long stem, earliness, and productiveness. Our White Enchantress, exhibited at the Carnation Convention at Washington, was the only White Enchantress exhibited that received an award.

Strong rooted cuttings, now ready for delivery, from sand \$6 per 100, \$50 per 1000; from soil, \$7.50 per 100, \$60 per 1000.

We offer also **Victory** and **Red Chief**, from sand, \$6 per 100, \$50 per 1000, from soil, \$7.50 per 100, \$60 per 1000. Also **Victory, Melody** and **White Perfection**, from sand, \$4 per 100, \$35 per 1000; from soil, \$6 per 100, \$45 per 1000. **Variogated Lawson, White Lawson** and **Red Lawson**, from sand, \$3 per 100, \$25 per 1000; from soil, \$4 per 100, \$35 per 1000. We can supply, also, **Winona** and **Alterglow** at \$12 per 100, \$100 per 1000.

Buyers will find transplanted stock offered from soil well worth the difference in price

F. R. PIERSON CO., - - Tarrytown-on-Hudson, NEW YORK

Single Chrysanthemums ARE THE CRAZE

for the time being.

Are you in line to meet the demand?

I have now ready

KATIE COVELL, ROB ROY, HELEN TOTTY, HAROLD BISHOP, MRS. UNTERMEYER, ANNA SPANGLE,

and others, at

\$2.00 per doz., \$15.00 per 100.

I also carry a full line of novelties and standard varieties of

Chrysanthemums, Carnations and Roses

CHAS. H. TOTTY, MADISON, N. J.

ASPARAGUS Plumosus Nanus

Seedlings from Flats, \$10.00 per 1000

A. N. PIERSON, CROMWELL, & CONN.

JOHN E. HAINES Bethlehem, Pa.

is the place to order rooted-cuttings of the following varieties for 1908.

John E. Haines, red	} Per 100 Per 1000
Imperial variegated	
Pink Imperial, Pink	
Enchantress, Light Pink	
Place your orders early for Jan. delivery.	

CARNATIONS ROOTED CUTTINGS

Winona, color, true clear pink, comes nearest to **Fiancee** but a different type flower. Growth on order of **Scott** but vastly improved in every respect. Early flowers in quantity and on long stems. Does not burst its calyx. Fine, shapely, active growth. In color and productiveness it is without an equal. Orders booked now and filled in strict rotation. \$12 per 100, \$100 per 1000.

White Perfection, pure white. We have a large stock. \$3 per 100, \$25 per 1000.

F. DORNER & SONS CO. LA FAYETTE, IND.

CARNATIONS WHITE ENCHANTRESS R. C.

This stock originated with and grown by me is the very best.

\$6.00 per 100, \$50.00 per 1000.

	Per 100	Per 1000
Enchantress, light pink,.....	\$2.50	\$20.00
Lawson,.....	2.00	15.00
Lord, light pink,.....	2.00	15.00
Queen, white,.....	2.00	15.00
The Belle, white,.....	2.50	20.00

250 at 1000 rate. Orders of 1000 or more will be shipped prepaid on receipt of check.

Get your R. C. early and have blooms when others have none.

FRANK H. KIMBERLY
631 Townsend Avenue, NEW HAVEN, CONN.

ROOTED CARNATION CUTTINGS

Only the Best Varieties

CHICAGO CARNATION CO., JOLIET ILL.

LLOYD IS THE REAL THING The Carnation for every one to grow

LLOYD is a commercial white, with a fancy flower

The only ever-blooming, large-flowering white in existence Will take the place of all other whites now in commerce. Every New Bedford grower has bought stock. Come and investigate.

**A KEEPER
A SHIPPER
A BLOOMER**

It will bring the shekels when all others fail

\$2 pr 12. \$12 pr 100. \$100 pr 1000
Unrooted Cuttings
\$6 per 100. \$50 per 1000.

H. A. JAHN
NEW BEDFORD, - - MASS.

Carnation Cuttings

Both standard varieties and novelties. Stock guaranteed to be first-class. Address,

S. S. SKIDELSKY
1741 North 18th Street, Philadelphia

FLOWER SHOW

Park Street Flower Market

SATURDAY, FEBRUARY 29, 1908

THIS, New England's greatest commercial show, promises to excel anything in its class ever held in the United States. An unprecedented aggregation of experts known throughout the country have charge of this exposition. The president and two ex-presidents of the American Carnation Society, and one ex-president of the American Rose Society lend the lustre of their names. The prize list offered is the most comprehensive ever offered for any similar event and insures a display of new and standard varieties never before equalled in America.

A cordial invitation is extended to all growers to attend and exhibit, and to all others interested in up-to-date floriculture to visit this show.

Exhibits from those unable to attend may be sent direct to the Flower Market, care George Cartwright, 1 Park St., Boston, where they will have the care of a competent committee who will see to it that they are staged to advantage.

Exhibition from 11 A. M. to 4 P. M. All exhibits must be staged by 10.30 A. M.

Schedule of prizes and list of committees will be found on another page of this paper.

COME ONE, COME ALL

"Bread from Stones"

This is the sixth in the series of articles upon soluble fertilizers by Mr. Pray. We can supply the preceding contributions on request.

Those who have considered the matter at all must now realize how important is the influence of fineness upon the speed with which even the "everlasting" rocks yield up what stores of plant food they may contain. The grinding to dust of rocks that has gone on for geological ages is the mighty "Mill of the Gods" that has stocked the rich valleys and spread our magnificent deep western soils which are so rich in possibilities for plant life.

Yonder hill-crowning-forest has enormous quantities of potash, phosphates, lime and magnesia. The same for that apple orchard on the rocky slope. Those trees have got their mineral water from those rocks. It can't be denied that somehow they have got a living, perhaps a precarious one, but nevertheless a living has been filched from those hard-featured stones which compose the hill. We can find the "goods" on them. That oak leaf has over 10 per cent mineral makeup.

By fine grinding we have been able to accelerate what takes place slowly under ordinary conditions to such a degree that recent experiments show that feldspar (which may have 10 per cent potash) when able to pass 200 mesh applied to tobacco plants seems to yield up its potash to a large extent. We are not going to make any prophecy until we know more. All this about rocks is no new thing and for years there have been ardent exponents of "Stone Meal Manure." One foreign proponent has come to the onslaught with a club called "Bread From Stones," hence the words above. In his preface he asks, "What Will Fertilizing With Stone Meal Accomplish?"

He says, "It will:

- (1) Turn stones into bread and make barren regions fruitful.
- (2) Feed the hungry.
- (3) Cause healthy cereals and provender to be harvested and thus prevent epidemics among men and diseases among animals.
- (4) Make agriculture again profitable and save great sums of money which are now expended on fertilizers that in part are injurious and in part useless.
- (5) Turn the unemployed to country life by revealing the inexhaustible nutritive forces which, unrecognized, are stored up in the rocks, the air and the water."

There is food for thought in the above, especially as to most granites and feldspars, which are abundant in this part of the country.

The German Kali (German for potash) Trust which imports tremendous amounts of Stassfurt potash salts in the various forms and purities and advertises in proportion hopped up into the air when they heard about potash from granite or feldspar. They have issued a nice little pamphlet all about it and condemn the idea of potash from any such source competing with Stassfurt mines, and the thing is ended once and for all.

As good Americans, we would like to feel independent of even Brother Wilhelm, but we fear granite rocks won't do it. The dream that appeals to the agricultural chemist is a country like New England full of waterfalls and potash in the rocks alongside, for potash can and has been extracted with aid of electricity from fine ground rocks at a much faster rate than water alone would do it. But the German potash salts still hold the field in price. Let us not curse Providence, however, for we have the phosphates in great abundance in the South, and we have hopes that Secretary Root didn't go

to Chile, the home of the nitrate deposits without casting an eye in that direction.

We have tried to start the idea of soluble fertilizers where we first note them and that is in Nature where they are dilute and slow coming, but finally "get-there."

Rudley M. Pray

Art and Nature in Garden Making



WINTER SCENE AT YORK COLLEGE
Sandringham, England.

We are told by the wise people that garden making is an art; they also inform us that this particular art is really an imperfect copy of Nature. This oft repeated statement at once sets me inquiring as to the truth of the remark.

To begin with, much depends on what we mean by "Nature." If we understand by that word merely certain phenomena, subject to fixed and unalterable law, we must admit that man has the power to imitate natural effects or adapt only, but not to create. Thus, all the arts and crafts of modern garden making are but permutations and combinations of natural laws, when we consider their adaptation to the garden, or rather I should say to that part of the garden which is in the immediate vicinity of the home. If, however, we consider that mere utilitarianism does not cover the whole field of our ideas, that we do not exist merely, but strive to obtain peaceful and natural surroundings, then we feel that the restless, unsatisfied efforts of the gardener in whatever way he seeks expression, point to a search for a something of which the visible universe is but the symbol. As a garden at the best is but Nature made more clearly visible to our senses, so it is that Nature can only be understood by those who can read the symbol. The true garden maker, therefore, I say, is not an imitator, but an interpreter.

All people do not see who gaze on the fair work of Nature, with its wonderful balancing of effects and its marvelous blending of colors. Few, indeed, scan it with purged vision. Few can pierce behind the veil, to the throne where Nature sits amid seven-fold splendor. Many people exist in the world to whom the beauty of

flowers and the majesty of the trees appeal in vain. Flowers spring from the ground, live, blossom, and fade away; trees burst into their drapery of green and fade away in regal splendor of purple and gold, but to such it has no meaning. Their eyes are nature-blind and that they cannot see.

The garden maker's function, therefore, is not merely to reproduce for us matchless combinations of color and effect with the various resources at his command. If this were all, his task would indeed be limited. It is his to trace for us the beauty and majesty revealed to us in the world around. Hence the true garden none the less reveals, but also seeks to convey the beauty and sacredness of that which is unseen, and the garden maker is the interpreter or High Priest of Nature.

If I have made myself clear in my deductions as to what is really meant by Art and Nature in garden making I may go still further and give an instance where they exist in perfect harmony with each other. The accompanying illustration depicts a winter scene at York Cottage, Sandringham, England, the beautiful country residence of the Prince of Wales. I would like to draw the reader's attention in particular, to the water effects. You will observe that there is an entire absence of anything which might be called extreme. The mere fact that they are the work of the garden maker and therefore in a sense artificial, does not conclusively prove that they are an imperfect copy of Nature. I should say rather, that the scheme as a whole was an intelligent interpretation of the wishes of Nature. The garden maker has here aspired to something more refined than mere imitation, and I venture to say that he has more than succeeded. He has given us a beautiful outline combined with well balanced effects. Perfect harmony in effect, perfect peace, perfect art, Nature perfect.

"That her fair form may stand and shine,
Make bright our days and light our dreams,
Turning to scorn with lips divine
The falsehood of extremes."

—Tennyson.



North Easton, Mass.

British Horticulture

SOIL INOCULATION

From time to time reports have reached this country with regard to the remarkable results produced by the bacterial treatment of the soil in America. The surprising results obtained were received with some incredulity by horticulturists on this side. These doubts, however, have been dispelled by the successful experiments which have been conducted in this country by Prof. Bottomley. In Scotland an inoculated acre yielded 3,070 pounds of beans, against 1,800 pounds from an acre not inoculated—a gain of 70 per cent. In Leicestershire, half an acre inoculated, yielded 180 stones of peas, against 66 stones from a half-acre not inoculated. Professor Bottomley has gone further than the American experimentors, having evolved cultures for various plants which were never expected to be amenable to the attacks of the nitrogen-fixing bacteria. It was shown that inoculated tomatoes grew more strongly than

those not treated, and ripened their fruits during the past year, while others did not. Strawberries showed an increased yield to the extent of 45 per cent., and came to perfection earlier.

FLORAL NOVELTIES

There is a bewildering array of novelties in the nurserymen's catalogues; a complete list would fill the pages of HORTICULTURE. Amongst the most notable are White Pearl Gypsophila—an improvement on *G. elegans*, the blooms being larger and snowy-white. A miniature-leaved smilax will be found very useful for decorative work. Sweet pea hybridists have been working for a good yellow. Further progress in this direction has been made by the introduction of James Grieve, which is described as a three-flowered sulphur self. From Germany a new Christmas or winter-flowering sweet pea in various tints is being sent out. In recent years a great advance has been made in the size, color and form of the pyrethrums. Lady Godiva is the name of a new double of a pretty, flesh-colored tint. In the single section the new comers comprise *Simpliciter*, bright rose; *Betrothal*, crimson with a white ring around the disc; *Pinkie*, bright pink; *Carmentis*, deep rose; *Cherry*, bright cherry, and others. New introductions of gladioli include *Lady Inehiquin*, orange-salmon; *Mrs. Chatham*, flesh rose violet, striped; *Peace Envoy*, white, orange centre with violet stripe, and *Kelway's Triumph*, crimson-white. In the begonia section we have *Mrs. J. B. Blackmore*, of a taking shade of salmon, and attractive form; *Millicent*, a new shade of rich flesh-pink color; *Purity*, a pure white of ideal form; *King Alfonso*, rich crimson-scarlet, and *Lady Wenlock*, rose-pink.

FRUIT AND VEGETABLES

Santa Claus is the appropriate name given to a pear ripening at Christmas. In shape it resembles a *Beurre Diep* or *Doyenne du Comice*, and the fruit averages from eight to ten ounces in weight. The new culinary peas are numerous. *Sutton's Reading Wonder* is an early dwarf variety, and *Sutton's Incomparable* is a fresh second-early suitable for table or exhibition purposes. *Carter's Advancement* is a new first-early obtained as the result of a cross between *Daisy* and *American Wonder*. A Russian Kale is being offered which has received an award of merit and a first-class certificate after a trial by the Royal Horticultural Society at Wisley. The leaves are rather remarkable in form somewhat resembling a deer's antler, and are of a curious green color. Since the decline in the potato "boom" there has been a falling off in the number of new aspirants for fame. *Daniels' Prince Edward*, one of the few fresh introductions this season, has been obtained as the result of a cross between the *Duke of York* and *The Factor*. It is a second early which has done well in the trials. *Talisman* is a white round main crop potato which is being distributed by a northern firm. A new melon, *Ideal*, is likely to receive the attention of growers. This has been produced as the result of a cross with *Ingestre Hybrid* and *Royal Favorite*. *Fiddler's Model* is the name of a new beet being sent out. It is considered an improvement both in form and quality on the old Egyptian turnip-rooted variety. A great advantage apparently is the early date at which it arrives at maturity.

W. H. Adsett.

Aquilegias



AQUILEGIA COERULEA

Whoever contemplates to plant a perennial border this spring should not omit to reserve sufficient space for an adequate plantation of columbines. Aquilegias rank high among herbageous flowers and are equally attractive in foliage. Not alone their merit as garden ornaments but still more their commercial value, both as plant and cutflower, should induce every florist and gardener to look out for an ample supply. In the New England States aquilegias thrive well in an open sunny position. They have proven eminently useful for natural woody park sections and likewise, now and then, for the rock garden. South of New York I have found it sometimes of advantage to plant them where they are somewhat protected from the hot midday sun rays. When dotted along the outskirts of natural woods it can easily be arranged to let them have some shade during noon hours and thus prolong their flowering season in June.

Among the varieties much favored by Maine summer cottagers are *Aquilegia coerulea* and *A. chrysantha*. The former is the well known mountain columbine, violet blue, with white center. The plant our illustration represents was taken in the Mount Desert Nurseries in Bar Harbor and shows habit of growth and free-flowering qualities to perfection. *Aquilegia chrysantha*, like the variety *coerulea* with spurred flowers, is in color bright yellow.

There are an abundance of other species in cultiva-

tion, many highly attractive and all interesting to the plant lover. Of these I mention the old European columbines, *Aquilegia vulgaris* in pink, white and blue shades. *Aquilegia canadensis* scarlet with yellow center, of medium size is rather odd in appearance. The large flowering *A. glandulosa*, the pure white columbine, *A. nivea grandiflora* and the beautiful mauve blue variety *A. olympica* are all very desirable acquisitions to any garden. If we add to those named the numerous new hybrids of more recent origin it becomes evident that we have at present a rich efficiency both in color and form at our disposal from which to choose.

Richard Roth

Hydrangea arborescens grandiflora

Editor of HORTICULTURE:

Dear Sir:—We accept with pleasure the slight change in the name of the new hydrangea as recommended by Prof. Sargent in the interest of scientific accuracy, and have notified Secretary Rudd of the S. A. F. to that effect: we are very grateful to Prof. Sargent for his kind offices, and are extremely glad to have the matter definitely and finally settled.

Thank you, Professor Sargent, *Hydrangea arborescens grandiflora* it shall be; and we will warrant that the American lady amateur will very promptly christen it a fetching descriptive name, in all probability the Snowball Hydrangea, but *Hydrangea sterilis* never!

E. G. Hill

Jamaicaway

Our frontispiece this week is instructive as a lesson in roadside planting in a style in which the Boston Park Department has taken the initiative. The border of shrubbery seen on the left is about eight feet wide and separates the roadway from the bridle path. It is planted mainly with viburnums, cornuses and privets. This method of planting is superior to the ordinary grass border, softening the too-often sharp edges of the parkways and adding greatly to the attractiveness of the scene. In some parts this effect is still further emphasized by plantations of wild roses, Indian currants, yellow root, *Pyrus nigra* and *arbutifolia*, *andromedas*, etc. In these borders there are planted at intervals of fifty feet the young red oaks which are in the future to furnish the permanent shading of the parkway. On the right hand side of the picture in the turf border separating the walk from the driveway some of these oaks may be seen.

HORTICULTURE

VOL. VII

FEBRUARY 22, 1908

NO. 8

PUBLISHED WEEKLY BY
HORTICULTURE PUBLISHING CO.
 11 Hamilton Place, Boston, Mass.

Telephone, Oxford 292

WM. J. STEWART, Editor and Manager

SUBSCRIPTION PRICE

One Year, in advance, \$1.00; To Foreign Countries, 2.00; To Canada, \$1.50

ADVERTISING RATES

Per Inch, 30 inches to page \$1.00.

Discounts on Contracts for consecutive insertions, as follows:

One month 4 times 5 per cent.; three months (13 times) 10 per cent.;

six months (26 times) 20 per cent.; one year (52 times) 30 per cent.

Page and half page spaces, special rates on application.

Entered as second-class matter December 8, 1904, at the Post Office at Boston, Mass.,
 under the Act of Congress of March 3, 1879.

CONTENTS

	Page
FRONTISPIECE—Jamaicaway, Olmsted Park, Boston.	
"BREAD FROM STONES"—Dudley M. Pray.....	229
ART AND NATURE IN GARDEN MAKING—Wm. Mc- M. Brown, Illustrated.....	229
BRITISH HORTICULTURE—W. H. Adsett.....	230
AQUILEGIAS—Richard Rothe, Illustrated.....	231
HYDRANGEA ABORESCENS GRANDIFLORA—E. G. Hill.....	231
JAMAICAWAY.....	231
AFTER ADJOURNMENT.....	233
A QUESTION FOR DR. GALLOWAY—Dudley M. Pray	233
CARNATION TEMPERATURES.....	233
BOSTON MARKET EXHIBITION.....	234
NEWS OF THE CLUBS AND SOCIETIES:	
St. Louis Florist Club—Morris County Gardeners' and Florists' Society—Massachusetts Horticultural Society—Chicago Florists' Club—Buffalo Florists' Club—Nassau County Horticultural Society.....	235
Gardeners' and Florists' Club of Boston—St. Louis Horticultural Society—Dayton Florists' Club—Club and Society Notes.....	236
SEED TRADE.....	238
CATALOGUES RECEIVED.....	238
ALASKA-YUKON-PACIFIC EXPOSITION—F. L. Her- rick.....	240
CARNATION BREEDING IN AMERICA—C. W. Ward.	242
FLOWER MARKET REPORTS:	
Boston, Buffalo, Chicago, Detroit, Indianapolis, New York, Philadelphia, Washington.....	245
VEGETABLES UNDER GLASS—Wm. Turner.....	253
MISCELLANEOUS:	
Commercial Fertilizers Sized Up.....	233
Disthorning Instrument for Roses.....	233
Library Notes—C. Harman Payne.....	233
Personal.....	233
A. F. J. Baur, Portrait.....	234
International Horticultural Exhibition at Ghent...	234
"The Private Gardener".....	234
Publications Received.....	238
Appraisers' Decision.....	238
Plant Imports.....	239
Fire Record.....	249
Chicago Retail Trade.....	243
Business Changes; Incorporated; News Notes.....	245
Greenhouses Building; List of Patents.....	254

Exclusively for the
commercial florist

The best way to know a man is to meet him face to face. Likewise the value of a flower is best ascertained by direct inspection. Especially is this true as regards a flower which is heralded as an acquisition commercially. That unique institution, the annual Boston Market exhibition, had its birth as a result of this need, years ago, and as each successive occasion has come and gone it has come to be recognized as an occasion of increasing importance to the flower growing community until, this year, the event takes on an importance hitherto hardly disclosed. The market exhibition announced in our advertising columns for the 29th inst. will undoubtedly bring together the largest assemblage of commercial florists seen in Boston since the meetings of the carnation and rose

societies two years ago. Leading men in the trade from far and near realize the possibilities of such an opportunity in the home of Lawson and Enchantress and those who want to get a line on the good things in carnations, roses, violets, etc., for next year will find it to their interest to be present while those who have been nursing new candidates in carnations, roses or anything else, for trade inspection, cannot afford to miss this unequalled means of publicity.

Planning the business campaign

In the present disturbed financial conditions and the approaching political struggle many wise heads think they see the presage of restricted business operations during the coming season. We, however, still believe that the unprecedented agricultural prosperity of our country may be depended upon to ward off any great degree of disaster and that much of the pessimism now current is not justified. But the prudent man will always be prepared for any exigency and it now behooves every one who desires to keep the volume of his business for this year up to last year's phenomenal record to take steps at once to extend his repute and widen his market through such means of publicity as are provided for him in the advertising columns of this paper. Now is the time to take full advantage of the opportunity for if there is to be any reduction in the aggregate of business this year, you may depend upon it that the lion's share of what is left will go to the conspicuous advertiser. In no other line of business is the cost of advertising in the professional publications so low, yet in none are the purchasing element more directly and effectively reached. Think it over and if you want your share of the business of 1908, don't delay any longer.

To safeguard the forests

A bill reported last week in the Massachusetts House of Representatives provides for the exemption from taxation for a period of ten years, under certain stipulated regulations, land planted to trees of any variety approved by the state forester. The problem of equitable taxation for timber lands is one not easy of solution, but perhaps more than any other economic question now before the American people, it demands attention and the penalty for delay is almost beyond conception. Some weeks ago Mr. C. W. Ward, who represents large timber properties in Michigan, delivered a lecture before the conference of the delegates to the Lake States Forestry Commission at Saginaw, in which he advocated the granting of a certain amount of relief from taxation to the owner of land devoted to the growing and perpetuating of a supply of timber so that he may be enabled to take steps to preserve his forest domains instead of cutting off all of the timber and turning the territory into wastes as is now being done. As Mr. Ward truly asserted, the method of taxing forest lands hitherto has had the effect practically of penalizing or fining the timber owner for preserving his timber, whereas the policy should be just the reverse—in fact, to make it expensive for the owner to destroy his timber and require him to make good a percentage of the value destroyed each year by maintaining young trees in quantity to insure a permanent income-bearing forest. Mr. Ward's argument was on irrefutable lines and it is gratifying to see that the subject is receiving attention from the same practical standpoint by the Massachusetts legislature. Happily the people are at last coming to realize how directly the floods, droughts, and extreme temperatures that vex them are due to forest destruction and popular support for any measure which promises to bring relief can now be counted upon.

AFTER ADJOURNMENT.

What a magnificent record carnation Winsor is making! Seldom do we find exhibition standard and commercial availability so fully united in one flower.

The philosopher of one of our exchanges remarks that "They's jest ez much room at the top ez they ever wuz, on'y it's further off." This condition is the penalty the rank and file must pay to their ambitious and progressive fellows. The man who is content to stay in the "average" class must pay this tribute in ever-increasing ratio. The only escape is to "get a move on," do things a little better than the other fellow and also see to it that the world knows it, by advertising, advertising, advertising, liberally and persistently. The "room at the top" will then come nearer and nearer, and it's largely your own fault if you don't get there.

COMMERCIAL FERTILIZERS SIZED UP.

Bulletin No. 119 of the Mass. Experiment Station gives the tabulated results of the analyses of commercial fertilizers during the season of 1907. The addition to the fertilizer law requiring the publication of valuations is stated, and the dealer's cash price, valuation and percentage of difference are placed opposite every fertilizer examined. The bulletin also gives the names of all fertilizer manufacturers selling in the state, as well as a complete list of the brands offered. Explanations make clear the character of the crude materials of which fertilizers are composed: the relative standing of the numerous firms is summarized in a table, and much other information is given that will prove of value to all buyers of commercial plant food. Those who have not received copies of these bulletins can have the same upon application. Requests should be addressed to the Agricultural Experiment Station, Amherst, Mass. Every man who uses fertilizers, outdoors or under glass, should read No. 119 carefully. He will find some surprises there.

A DISTHORNING INSTRUMENT FOR ROSES.

Every rose specialist knows how hindering to the work of preparing rose stocks are the strong thorns, and he will welcome an instrument that will render the work safer and more rapid, with at the same time freedom from danger to the stocks, etc., and the man who works it. Three hundred stocks per day was the output for one man working in the old manner, whereas from 3,000 and more can readily be cleared of thorns by the instrument. In the interior of the instrument there are six knives arranged in a circle. The apparatus being opened the rose stock is laid in a trough, and on closing the stock is clasped by the six knives, and pushed backwards and forwards twice or thrice, the thorns falling through an opening on the underside. It can be fixed by means of four screws to a heavy, or immovable bench or table—*Horticultural Trade Journal, London.*

A QUESTION FOR DR. GALLOWAY.

Editor HORTICULTURE: Being keenly interested in fertilizers and having a "penchant" for the clean, odorless, soluble kind, the work on carnations by the Bureau of Plant Industry excited me with the possibility that these modern agents may have been used in this case. The article on Experiments in Carnation Growing by the U. S. Dept. of Agriculture, as printed in the issue of Feb. 15, page 201 of HORTICULTURE, gives a complete fertilizer, which means one having these three principal ingredients, thus: N. 8 per cent., available phos. acid 12 per cent. and potash 8 per cent. Now here are the facts that the readers of your paper may be glad to know. This fertilizer was made up of nitrate of soda, nitrate of potash, dissolved South Carolina rock and sulphate of potash. This, then, is not a commercial fertilizer but mainly a mixture of soluble chemicals. We do not at this writing know how this was applied; when, how strong or how often, but must await more light from the doctor.

The report says that Dr. Galloway "cautioned the grower to go slow on commercial fertilizers and to put their faith and work into good composts." We admit that this staggers us, for by the table before us the complete fertilizer beats the rest six times in eight, and in every case where flat soil was used.

We think the doctor really meant to say that good organic rotted matter was best to start with and then not to feed with commercial but with soluble chemicals, as probably was done in this case, but we will await further advices from the Bureau.

DUDLEY M. PRAY.

CARNATION TEMPERATURES.

To the Editor of HORTICULTURE:

Being in the commercial business and growing flowers, etc., for the New York wholesale market, I would like to know through the valuable columns of your paper what the best temperature would be day and night to grow the following varieties of carnations: Enchantress, Helen Gould, White Enchantress, Rose Pink Enchantress, Beacon, Victory, Robt. Craig, White Perfection, Mrs. Patten, Winsor, Gov. Roosevelt, Afterglow, Sarah Hill. Boston Market, Lieut. Peary. My Lieut. Peary is inclined to go to sleep on the plant. What is the reason, and do you think it is a good commercial variety?

A subscriber to HORTICULTURE, one of the most successful growers of carnations, who prefers his name should not be mentioned, replies to the above as follows: "Most carnations do well at a night temperature of 50 to 52 degrees, and a day temperature of 40 to 45 degrees higher; Winsor, 53 to 55. Afterglow and Sarah Hill have not been grown by the trade yet. Lieut. Peary is inclined in some places to be sleepy, in others does very well and is considered a profitable variety."

It should be remembered the successful growers do not all travel in the same beaten track, and we would advise the inquirer to visit Cottage Gardens Co., Dailledouze Bros. or F. R. Pierson Co., at all of which places he will see carnations at their best.

LIBRARY NOTES.

[Any of the books mentioned in Mr. Payne's reviews can be supplied at publishers' price from the office of Horticulture.]

My Rock Garden by Reginald Farrer. (Edward Arnold, London). This is a rather more imposing volume than the preceding, for it runs into more than 300 pages. Mr. Farrer writes in a most readable style and the book as a literary production deserves our warmest praise. From a practical point of view the lover of a rock garden, and there are many, will derive much instruction from a perusal of its pages. Price, \$2.00.

The Gardens of England. (The Studio, London, Paris and New York). A very attractive volume issued as the winter number of "The Studio," a monthly periodical devoted to art. It is almost wholly composed of full paged, beautifully executed photographic views in the gardens of England in the southern and western counties. The letterpress, which only forms a quarter of the volume, deals with the history and principles of garden making and notes on the numerous illustrations. Simply speaking from the florists' standpoint we must express the pleasure that we derive from looking at such interesting garden views as Stratton Park, Hanks, Herbaceous flower border at Orcharleigh Park, Rock Garden at Killerton, Pampas Walk at Hinton Admiral Garden front at Daw's Hill Lodge, Blenheim Palace, Gardener's Cottage at Ashridge Park, The formal garden at Taplow Court, Old place, Lindfield, Old orangery at Ham House.

C. HARMAN PAYNE.

PERSONAL.

The trip to Richmond, Ind., by the Indianapolis florists has been postponed to February 26.

Visitors in Boston this week: Alex. McWilliams, Wm. Boyd and J. H. Davidson, all of Newport, R. I.; Henry Wild, Greenwich, Conn.

Jesse Pierce, nurseryman, Beverly Farms, Mass., has purchased an additional tract of land to accommodate his increasing business.

A. R. Robbins, of Robbins Bros., florists, Cambridge, Mass., while crossing the street on the evening of February 4, was struck by an auto and severely bruised.

Arthur G. Macdonald, head gardener to Mr. Luther Kountze, Morristown, N. J., will sail from New York March 1 for Blairgowrie, Perth, Scotland, for an extended stay.

Visitors in Chicago: A. C. Beal, Champaign, Ill.; Heint Bros., Jacksonville, Ill.; Martin Reukauf, representing H. Bayersdorfer & Co., Philadelphia; Henri Killen, New York.

A FRANK TESTIMONIAL.

My ad. with you has proved the most effective of any thus far.

CHAS. A. KIRBY.

Elmhurst Ill.

THE BOSTON MARKET EXHIBITION

This annual affair, regarded with so much favor by the New England florist trade, will be held at the Park Street Market, Boston, on Saturday, February 29, from 11 a. m. to 4 p. m. As will be seen by consulting the following list of regular and special premiums, the inducements for a large display are tempting and will doubtless draw out a notable line of exhibits.

CARNATIONS.

Class A		1st.	2nd.
50 Crimson	\$5.00	\$3.00
50 Dark Pink	5.00	3.00
50 Light Pink	5.00	3.00
50 Scarlet	5.00	3.00
50 White	5.00	3.00
50 Any other color	5.00	3.00

Class B

25 Crimson	\$3.00	\$2.00
25 Dark Pink	3.00	2.00
25 Light Pink	3.00	2.00
25 Scarlet	3.00	2.00
25 White	3.00	2.00
25 Any other color	3.00	2.00

Class C

100 blooms in one vase, not less than 6 varieties. 1st, Solid Silver Cup, valued at \$25.00; 2nd, Solid Silver Cup, \$7.50.

In classes A, B and C only standard or disseminated varieties can compete.

Class D

Vase of 100 blooms one variety, new or standard. Cup valued at \$25.00.

Vase of 25 new striped variety. First, \$5.00; second, \$3.00.

Vase of 25 blooms unnamed seedlings. First, \$8.00; second, \$6.00; third, \$4.00.

Class E

Special premiums offered by firms or individuals:

A. H. Hews & Co., cup valued at \$25.00 for 6 varieties of carnations, 50 blooms in a vase.

F. R. Pierson Co., Tarrytown, N. Y., prizes for 25 blooms of Winsor; first, \$6.00; second, \$1.00.

Peter Fisher, prizes for best 50 blooms of Beacon, \$6.00, best 25 blooms of Beacon, \$3.00.

ROSES.

	1st	2nd	
25 American Beauty	\$10.00	\$5.00
25 Pink	10.00	5.00
25 Red	10.00	5.00
25 White	10.00	5.00
25 Any other color	10.00	5.00

Park Street Flower Market, prize for best new rose to be disseminated in 1908, silver cup valued at \$25.00.

Wm. E. Doyle, for the best 25 Killarneys, silver cup, value \$25.00.

A special prize of solid silver cup and certificate of merit will be awarded to the exhibit showing the highest cultivation.

MISCELLANEOUS.

	1st	2nd	
Vase of 50 Tulips	\$5.00	\$3.00
Vase of 50 Narcissus	5.00	3.00

Collection of cut Bulbous stock, not more than 25 of a variety	12.00	8.00
Best 50 Lily of the Valley	3.00	
Best 50 Marguerites	2.00	
Best 25 Mignonne	3.00	
Best 100 Pansies	2.00	
Best 25 Anfirrhinum	3.00	
Display of novelty not otherwise classified	5.00	3.00

SWEET PEAS.

	1st.	2nd	
Vase of 100 White	\$3.00	\$2.00
Vase of 100 Pink	3.00	2.00
Vase of 100 any other color	3.00	2.00

A. C. Zvolanek Trophy valued at \$25.00 for two vases of 200 each, Florence Denzer and Christmas Pink sweet peas.

VIOLETS.

Only foliage of the variety exhibited can be used.

	1st.	2nd.	
100 Campell	\$3.00	\$2.00
100 any other double	3.00	2.00
100 Princess	3.00	2.00
100 any other single	3.00	2.00

James Wheeler Trophy for best New Violet, 200 blooms, Silver Cup valued at \$25.00.

SPECIAL PREMIUM.

Best exhibition from any grower selling his product at Music Hall Market; 1st, \$10.00; 2nd, \$5.00.

POT PLANTS.

Thirty square feet of space will be allotted to any exhibitor of pot plants. Suitable awards will be made for any exhibit of especial interest or merit.

IMPORTANT.

All exhibits must be staged by 10.30 o'clock A. M. It is very important that this rule should be observed as the exhibition is of short duration. Judges to be allowed to call for any information or assistance necessary.

RULES FOR JUDGES.

Carnation Scale of Points.

This scale shall be employed in judging all seedlings for Certificate of Merit, or for any special prize, and, in all classes where competition is close, it shall be used to arrive at a decision.

Color	25	Substance	10
Size	20	Form	15
Calyx	5	Fragrance	5
Stem	20			
Total 100				

LIST OF COMMITTEES.

Arrangements.—W. H. Elliott, chairman, Brighton; Geo. Cartwright, secretary, Park street, Boston; E. Allan Peirce, treasurer, Park street, Boston; S. J. Goddard, Framingham; Wm. Sim, Cliftondale.

Judges.—S. J. Reuter, Westerly; R. E. Thos. Roland, Nahant; A. H. Fowkes, Newton Highlands; E. A. Wood, West Newton.

Carnation Committee, E. Allan Peirce, Waltham; S. J. Goddard, Framingham; Wm. Nicholson, Framingham; M. A. Patten, Tewksbury; Peter Fisher, Ellis.

Rose Committee, W. H. Elliott,

Brighton; Alex. Montgomery, Natick; Eber Holmes, Montrose; Harry Budlong, Providence, R. I.

Violets, Sweet Peas and Miscellaneous.—Wm. Sim, Cliftondale; Wm Spilsbury, Woburn; Thos. Pegler, Park street, Boston; H. F. Calder, Norwood.

Plants and Bulbs.—L. W. Mann, Randolph; E. Sutermeister, Readville; Thos. Roland, Nahant; Frank T. White, Holbrook.

A. F. J. BAUR.

A. F. J. Baur, the young and energetic Vice President of the American Carnation Society, is a native of Pittsburgh, Pa., and is 32 years of age. When a boy of 13 he began his horticultural training with F. Morat's Sons at Louisville, Ky., since which time he has been five years with the E. G. Hill Co., one year with Stuart & Haugh, two years as foreman for H. A. Niemeyer of Erie, Pa., and in 1899 started in business with F. S. Smith under the firm name of Baur & Smith, where he has made carnations



A. F. J. BAUR

a specialty and raised many seedlings, some of which have made a good record on the market. He was elected Secretary of the State Florists' Association of Indiana last year and Vice President of the American Carnation Society at the Washington meeting.

INTERNATIONAL HORTICULTURAL EXPOSITION AT GHENT.

The centennial exposition of the "Societe Royale d'Agriculture et de Botanique" of Ghent, Belgium, will be held in the gardens of the Casino from April 23 to May 3, 1908. This exposition is held regularly every five years, and the coming one being the centennial, the display promises to be exceptional in extent and interest.

"THE PRIVATE GARDENER."

This is the title of the lecture which Robert Craig of Philadelphia will deliver before the Massachusetts Horticultural Society on Saturday, February 29th. Mr. Craig is a forcible speaker, understands his subject and will undoubtedly draw a large audience.

NEWS OF THE CLUBS AND SOCIETIES.

ST. LOUIS FLORIST CLUB.

The Florist Club meeting which took place on Feb. 13 was one of the best attended and most interesting meetings in its history. The attendance numbered over fifty. The attraction was our annual carnation exhibition, which was a large one and gave the local growers plenty to talk about. Exhibits from outside growers were not as extensive as usual, but the local growers came forward and showed well-grown standard varieties. James W. Dunford exhibited Aristocrat, Rose Pink Enchantress and White Perfection; J. W. Pilcher, Beacon; E. W. Guy, Lady Bountiful and Rose Pink Enchantress; St. Clair Floral Co., New Pink Seedling No. 20; Henry Johan, very fine Aristocrat; J. F. Ammann, extra fine mixed varieties; John Steidle, mixed varieties; P. Schnider, Pink Enchantress, Enchantress, T. W. Lawson and Lady Bountiful; Chas. Beyer, Enchantress.

Among the new varieties shown were, by the Chicago Carnation Co., an extra fine vase of Andrew Carnegie; Stevenson Bros., of Baltimore, Md., a vase of Splendor, and Richard Witterstaetter, a large vase of Afterglow. These were great attractions for the local growers.

The meeting opened promptly at 2.30, President Young presiding. The Committee on the Pottery Question reported \$2000 in subscription, and will continue until the allotted time, 5th May, to raise the \$10,000 subscription. The Trustees reported that the present meeting hall would have to be vacated by the end of March. They were instructed to find new quarters by next meeting. The Horticultural Society, through its Secretary, O. G. Koenig, in a letter asked the members to assist in making their spring flower show a success; this matter was left to the Trustees to act upon as they see fit.

Treasurer Weber was instructed to pay the first 20 per cent. call for the National Flower Show. It was also decided to hold our yearly Rose Show on March 12th at the old meeting place.

Fred Ammann addressed the members on behalf of the Illinois State Florists' Association, and invited the members to attend the meeting Feb. 18 and 19 at Springfield, Ills., and twenty members decided to make the trip.

The judges, Messrs. Fillmore, Ude and Bentzen, reported as follows: On Rose Pink Enchantress, J. W. Dunford first, E. W. Guy second, White, J. W. Dunford's White Perfection first, Schnider's Bountiful second and Guy's Bountiful third. Red, Pilcher's Beacon first, Aristocrat, J. W. Dunford, first, and Henry Johan second. Lawson, P. Schnider first, Enchantress, J. W. Dunford first, P. Schnider second, Chas. Beyer third. In the mixed vases, J. F. Ammann took first and John Steidle second and third. In the new varieties class, R. Witterstaetter's Afterglow took the club's certificate of merit, and Splendor,

Carnegie and Seedling No. 20 took honorable mention.

The question box was next opened, and some very interesting discussions took place. This ended the February meeting, and President Young invited all to a supper which was prepared by the trustees in the cafe below the meeting hall, at which forty sat down to spend the rest of the evening. The President announced that at the next meeting, in March, our rose meeting, the same thing will take place in the cafe, and he hopes for even a larger attendance.

MORRIS COUNTY GARDENERS' AND FLORISTS' SOCIETY.

Thirty-eight members met to hear C. H. Totty discuss The Merits and Defects of the New Chrysanthemum, which he did in a candid and interesting way. A general discussion took place as to why varieties so soon deteriorated, and many theories were advanced. In-breeding in the producing of seedlings was a theory that found favor with many.

We had a very creditable monthly exhibit. A. Herrington had a fine vase of carnation Beacon, C. H. Totty had White Perfection in all her glory; in this vicinity very few split calyxes are reported. A. R. Kennedy brought White Enchantress and Victory, the latter considered the best ever shown here. Cultural certificate was awarded to each.

From Florham Farms came a neat collection of hothouse vegetables and also some stocks, Beauty of Nice and Queen Alexandra, in 4-in. pots; one would hardly believe it possible to produce such spikes in such small pots. W. A. Manda, South Orange, had a new cerise pink carnation seedling, No. 20. Wm. F. Lyons had a white hybrid calanthe. Robt. Scott & Son of Sharon Hill, Pa., sent a vase of new Rose Mrs. Jardine, which got a certificate of merit.

Our next meeting, on March 11th, will be Carnation Night, and with so many novelties in the market we ought to have a show better than we ever had. A prevailing impression among gardeners is that while an introducer's word may be all in good faith, there is nothing like seeing a variety on the exhibition table. We will invite novelties as far as we can, but would be glad to have every novelty on the market here. However, we bank on a fine show and a good time. Some of our Orange brothers are coming up, and as we invite standard varieties, too, they may surprise us, as there are carnations in that vicinity equal to any in this country.

E. REAGAN.

MASSACHUSETTS HORTICULTURAL SOCIETY.

On February 29th, Robert Craig of Philadelphia will deliver a lecture at Horticultural Hall, Boston, on "The Private Gardener." The lecture will begin at 11 A. M.

CHICAGO FLORISTS' CLUB.

The Chicago Florists' Club held its meeting in Handel Hall, February 16, President Kill presided and got down to business in fine order. Applications for six new members were received and favorably passed upon for election at the next meeting. The agreement between the Art Institute of Chicago and the Club as pertaining to the use of the hall for the Rose Show, was accepted and August Poehlmann was chosen for manager of the exhibition, which will continue from March 25 to 27, inclusive. It was voted to have a banquet in connection with the visit of the American Rose Society and the president appointed a committee to make arrangements accordingly. A discussion was brought up as to the advisability of securing a new place of meeting. This will be further considered at the next meeting. The president announced chairmen of various standing committees as follows: Finance, H. N. Bruns; sports and pastimes, Philip C. Schupp; transportation, F. F. Benthey; good of the club, T. E. Waters. A vase of flesh-colored seedling carnations exhibited by Fritz Bahr, Highland Park, Ill., was awarded a club certificate, scoring 85 points. A. C. Beal, of Champaign, Ill., was a visitor and spoke at length on the coming meeting of the Illinois State Florists' Association at Springfield. T. E. WATERS, Sec'y.

BUFFALO FLORISTS' CLUB.

A well attended meeting of the Buffalo Florists' Club was held at Kasting Company's Hall on Friday night last. Business of importance took up considerable time as twenty new applications were acted upon. The twenty new members elected being of young blood, it now looks as if the club will be boomed and better attendance assured at meetings hereafter. Entertainment and other committees will be appointed. Nominations of officers for ensuing year were as follows:

President, Charles Sandeford and Charles Weichert; vice-president, David Scott and George McClure, Jr.; secretary, Rowland Cloudsley; financial secretary, E. C. Brucker; treasurer, W. H. Eiss.

Interesting talks by the past officers, L. Neubeck, Wm. F. Kasting, Charles Keitch, and others were much appreciated. A fine lunch and refreshments were served in the banquet hall, and a good evening's entertainment was enjoyed.

The next meeting is called for Friday, March 6th, when election of officers will take place and the annual banquet will follow. E. C. B.

NASSAU COUNTY HORTICULTURAL SOCIETY.

The N. C. H. S. held its regular monthly meeting at the Oriental Hotel, Glen Cove, Feb. 12, with a large attendance. In the competition for points the awards were as follows: S. J. Trepass, Cattleva Trianae, 89; H. F. Meyer, carnations, 84; Valentine Clores, narcissi, 83. As Mr. Henry

FORMOSA

LILIUM LONGIFLORUM

Ask your dealer for our own special grown stock or write us direct for quotations. Only a limited quantity available for the coming season 1908. Delivery will be made the first part of August. The bulbs are thoroughly ripened one month before the Bermuda Harrisii and are considered far superior in quality as they are *entirely free from disease*.

Careful trials were made for two years and were so successful that we imported over 300 cases last season. Our cases will be marked Y. N. Co.

YOKOHAMA NURSERY CO., Ltd., 31 Barclay Street, NEW YORK

Matz is going into business in Connecticut he tendered his resignation as treasurer to the society, and was given a vote of thanks for his services. E. J. Brown was unanimously elected to fill the position.

GEORGE M. KURZ, Cor. Sec'y.

GARDENERS' AND FLORISTS' CLUB OF BOSTON.

Wallace R. Pierson, of Cromwell, Conn., will be the lecturer before the G. & F. Club, of Boston, at Horticultural Hall, on the evening of Tuesday, February 25. Mr. Pierson's subject will be "Carnations," a branch of horticulture in which he is well versed and the opportunity of listening to him will be embraced by a record attendance. F. R. Pierson, H. A. Jahn and other visitors are expected to be present and join in the discussion and contribute to the exhibition which promises to surpass anything hitherto seen at a meeting of this club.

ST. LOUIS HORTICULTURAL SOCIETY.

The St. Louis Horticultural Society will hold a spring flower show next month, but on a much larger scale than last year. The executive committee met recently and elected C. C. Sanders chairman of the committee. The committee has decided this year to charge 25 cents admission. The selection of the hall has not yet been made, but Mr. Sanders says most likely the dance hall would be used in the Masonic Temple building. The local florists will no doubt help all they can to make the show a great success.

DAYTON FLORISTS' CLUB.

Resolutions on the Death of J. B. Heiss.

"There is a Reaper whose name is Death;
And with his sickle keen
He reaps the bearded grains at a breath,
And the flowers that grow between."

The passing of Joseph B. Heiss brought grief to all who knew him. His personal qualities were such as made him loved by all who knew him for what he was. His long residence in Dayton was devoted to the doing of his part in the building up of the city. Realizing in a measure what a great loss his sudden taking away means to the community, we desire to offer our tribute of respect. The poor words at our command are inadequate to express our sorrow! Let the following resolutions, adopted at a meeting of the Florists' Club, serve as they may to show our love and respect.

Be it Resolved, That in the death of Joseph Heiss, our first President, the Florists' Club loses a faithful member, a strong friend. We mourn his loss deeply. None knew him but what valued his friendship and all can scarcely realize that he will meet no more with us on earth. His place in our hearts is sure.

Be it further Resolved, That these expressions be made a part of our records. Also, that a copy be sent to Mrs. Heiss, whose sorrow is our own. Copies of these resolutions are sent to the Florists' trade publications and the Dayton Press.

H. H. Ritter, Geo. Bartholmew, John Bohner, Committee.

CLUB AND SOCIETY NOTES.

P. W. Ayers, forester, will lecture before the Worcester County Horticultural Society, Worcester, Mass., on February 27; subject, "Forestry."

Robert Cameron, of Harvard Botanic Garden, Cambridge, Mass., will address a meeting of the Newport Horticultural Society, Feb. 25, on "Annuals and Biennials." This will be Mr. Cameron's first visit to Newport in the capacity of lecturer and there is no doubt a cordial reception will be his.

The Dayton Florists' Club sent to the funeral of ex-President J. B. Heiss a beautiful cross of roses, carnations, hyacinths, lilies and sweet peas. The design stood six feet high, rising from a rich base of American Beauty roses. A ribbon bore the inscription, "Our First President—Dayton Florists' Club."

The twenty-first annual dinner of the New York Florists' Club will be held Saturday evening, February 29th, 1908, at the St. Denis Hotel, Broadway and 11th St., at 7 o'clock. The price of tickets is \$5.00 each to members and their guests. Contributions of flowers for the decoration of the tables will be welcome and may be sent to W. F. Sheridan, 39 West 28th Street. Committee: Wm. Marshall, R. M. Schultz, A. M. Henshaw, L. B. Craw, Walter F. Sheridan.

THE BOSTON VIOLET

The people today are looking for New Violets just as much as they are for new roses or carnations.

THE BOSTON VIOLET

For the past two years has been placed before the most sceptical buyers in America and they prefer it to any other.

THERE'S A REASON

The Boston Violet is the largest, the most fragrant, it has a very pleasing color, and it is a great keeper.

THE BOSTON VIOLET

Is a variety that is early grown, it is the strongest grower and is in crop from September to May.

THE BOSTON VIOLET

Was awarded a First Class Certificate of Merit by the Massachusetts Horticultural Society and a Report of Superior Merit by the Gardeners' and Florists' Club of Boston.

Distribution will Commence in April. Order Now.

PRICES—\$2 per 12 ; \$12 per 100 ; \$100 per 1000.

WILLIAM SIM, : : CLIFTONDALE, MASS.

Hardy Roses

American Grown—Superior to Imported

We have unsold at the present time the following varieties—all field grown plants, grown in our nurseries at Rochester, N. Y.:

- | | |
|---------------------|-----------------------|
| Anne de Diesbach | Prizee Camille |
| Olo | Ulrich Brunner |
| Frau Karl Drnschki | Crimson Rambler |
| General Jacqueminot | White Rambler |
| John Hopper | Yellow Rambler |
| Mme. G. Lulzet | Philadelphia Rambler |
| Marshall P. Wilder | Common Sweet Briar |
| Mrs. John Laing | Mme. G. Brunt |
| Paul Neyron | Wichuriana (The Type) |

These plants are in our storage cellars and can be shipped at any time. Prices on request.

ELLWANGER & BARRY

Nurserymen—Horticulturists
Mount Hope Nurseries, Rochester, N. Y.

Hardy Rhododendrons Azaleas Conifers, Clematis, H. P. Roses, Shrubs and Herbaceous Plants from our

HOLLAND NURSERIES

Prices Moderate

P. OUWERKERK, 246 Jane St., Weehawken Heights
P. O. No. 1, Hoboken N. J.

AMERICAN NURSERY COMPANY COMBINING

FRED'K W. KELSEY New York City
F. & F. NURSERIES Springfield N. J.
BLOODGOOD NURSERIES, Finishing, L. I.
N. J. & L. I. NURSERIES.

We Can Supply Your Every Need. Write for Prices

SALES DEPARTMENT, 150 Broadway
New York.

Established 40 Years

Rose Hill Nurseries

New and Rare Plants

NEW ROCHELLE, N. Y.

New York Office, Siebrecht Building, 425 Fifth Avenue

JOHN WATERER & SONS, Ld. American Nursery, Bagshot, England

Are Specialists in the

REALLY HARDY VARIETIES

of Rhododendron Hybrids and in Select Varieties of Hardy Border Plants.

ROSES FOR FORCING | Immediate Delivery Strong-Dormant | Send for Prices and List

American Beauty, Clothilde Soupert, Gloire de Dijon, Hermosa, Kaiserin A. Victoria, Killarney, Liberty, La France, Madame Cochet, Marechal Neil, Mrs. R. G. Scharman-Crawford, Marchioness of Londonderry, Souv. de la Malmaison, including all the leading varieties of Hybrid Perpetuals.

BAY STATE NURSERIES, No. Abington, Mass.

NEW — NEW — RAMBLER ROSE "NEWPORT FAIRY"

To be disseminated Spring, 1908. Ask for Illustrated pamphlet and prices

JULIUS ROEHRS CO., Rutherford, N.J.

SPECIMEN EVERGREENS

Box Plants, Azaleas, Rhododendrons, Roses, Herbaceous Perennials

In fact everything in hardy stock for Garden, Lawn and Landscape Planting.
General Catalogue and Trade Lists on application.

The NEW ENGLAND NURSERIES, Inc., Bedford, Mass.

Seed Trade

The export of seeds from the United States amounted in 1906 to \$14,239,121 and in 1907 to \$8,856,152.

The imports of seeds and plants from the consular district of London to the United States in 1907 amounted to \$1,128,502.

CATALOGUES RECEIVED.

F. H. Ebeling, Syracuse, N. Y.—Seeds, Bulbs, Implements, etc. Cover in colors.

Wood Bros., Fishkill, N. Y.—Trade list of Florists' Stock for January to May, 1908.

J. Murray Bassett, Hammon, N. J.—Special Catalogue of Bassett's Dahlia Roots for 1908.

Illinois Heater Manufacturing Co., Chicago, Ill.—Descriptive Price List of Illinois Self-Watering Flower Boxes.

R. & J. Farquhar & Co., Boston, Mass.—Wholesale Catalogue of Florists' Flower Seeds and New Dahlia Charles Lanier.

Abenroth Brothers, Port Chester, N. Y.—Gem Heaters for Steam and Hot Water Warming. Illustrated descriptive price list.

B. Hammond Tracy, Wenham, Mass.—Cedar Acres Gladioli. A neat little pamphlet with the crimson variety Harvard in colors as a cover illustration.

W. Atlee Burpee & Co., Philadelphia.—Burpee's "Blue List," giving wholesale prices for 1908 for market gardeners and florists. A splendid list, illustrated and making a book of over 100 pages. Colored illustrations of Burpee's Matchless, Chalk's Early Jewel and Sunnybrook strain of Sparks' Earliana tomatoes are included.

PUBLICATIONS RECEIVED.

La Bibliographie du Chrysanthème. This is the title of a pamphlet compiled by C. Harman Payne, F. R. H. S., being a reprint of a contribution to the Journal of the National Horticultural Society of France. The list of publications included in this index includes all known pamphlets and treatises on the chrysanthemum published hitherto in Europe and America and will prove a very useful reference index for those who are interested in the history and cultivation of the golden flower.

Forest Trees of Massachusetts: How You May Know Them. A pocket manual by David A. Clarke, under the direction of F. W. Rane, State Forester, Boston, Mass. This handy volume presents a practical working description of the commercial trees at the command of the Massachusetts citizen in a plain and untechnical manner. Drawings in illustration of the text are freely introduced. The author, Mr. Clarke, is a Harvard instructor, of recognized experience and ability in forest botany. He is well-known to our readers as a frequent contributor to our columns. This handbook, which it is hoped will be a source of inspiration towards assist-

ing people in identifying the native trees, is offered by the State, free of charge, and may be obtained on application to F. W. Rane, State House, Boston, Mass.

The Report of the Secretary of Agriculture on the Southern Appalachian and White Mountain Watershed has just been issued. It is a comprehensive and convincing statement of the commercial importance, area and condition of these wild forest tracts, the advisability of their purchase for national forests and the probable cost. Two maps are included. The recommendations of the Secretary of Agriculture in this document are exceedingly moderate and conservative and the national government can do no less than to adopt and put them into effect. It might wisely do more but on the principle that half a loaf is better than no bread the Secretary undoubtedly is taking the best course. No more important or patriotic duty confronts our national legislators than to save from threatened destruction these remnants of our great protective forests.

Landscape Gardening for Amateurs, accompanied by a selection of one hundred detailed plans of lawns and gardens with key to planting. Wagner Park Conservatories, Sidney, Ohio. This handsome album is a credit to the author, Mr. B. P. Wagner. It is illustrated with numerous fine half tones on heavy coated paper and is appropriately dedicated "to those who love beautiful surroundings." The various chapters are devoted to the following subjects: Landscape Gardening for Home Grounds; How to Make the Back Yard Attractive; Formal and Old-Fashioned Gardens; Improving School Grounds; Improving University and Sanitarium Grounds; Improving Factory Surroundings; Improving Hotel and Pleasure Resorts; A Plea for the Improved Public Square, Play Ground, Park and "Town Beautiful"; Vines; Attractive Verandas and Window Boxes; Decorative Plants; Desirable Bedding Plants; Hardy Plants; Hardy Shrubs and Pruning; How to Plan and Plant Hardy Flower Beds; Roses; Shade and Ornamental Trees; Hedges; Plans. We are glad to devote a little extra space in calling the attention of our readers to this publication because it is in exact line with sentiments often expressed by HORTICULTURE and because it is worthy of emulation by florists and gardeners generally. We hope that the book will fulfil its mission of stimulation and instruction in beautifying out-door surroundings. The price is \$1.00.

The annual banquet of the Lenox Horticultural Society, Lenox, Mass., February 15, was attended by ninety guests, including ladies, an innovation which will undoubtedly become a regular feature of these festive occasions hereafter. Alex. MacConnachie was toastmaster; instrumental and vocal music and recitations made the evening pass pleasantly.

You will find something worth reading on every page of HORTICULTURE.

Quality the First Requisite

FOR OVER SIXTY YEARS WE HAVE SUPPLIED THE PRIVATE AND COMMERCIAL GROWERS

Giant Cyclamen, best strain and colors, 100 seeds \$1.00, 1000 seeds \$9.00
Asparagus Plumosus Nanus, 100 seeds 75c, 1000 seeds \$5.00.
Asparagus Sprengeri, 1000 seeds 75c.
Cosmos, early White and Pink, 20c trade pkt., \$1.00 oz.
Tuberose Excelsior Pearl, \$1.00 per 100, \$3.50 per 1000.
Begonia, single tuberous rooted, in colors, \$3.00 per 100
Gloxinia, Red, White, Blue and Spotted, \$4.50 per 100.
Scotch -oot, Bamboo Canes, etc., etc. Send for catalogue. Wholesale list to trade only.

SCHLEGEL & FOTTLER CO.
26-27 So. Market St., Boston, Mass.

MICHELL'S SEEDS
Are Always Reliable.
1018 MARKET ST. PHILA.
WHOLESALE CATALOGUE FREE

GLADIOLI

I can satisfactorily supply your wants for Gladioli for forcing or outdoor planting. Mixtures, color sections or named varieties of exceptional beauty.

Write for Prices

ARTHUR COWEE

Gladiolus Specialist

Meadowvale Farm, BERLIN, N. Y.

HYACINTHS, TULIPS, NARCISSI

AND OTHER BULBS

ROMAN HYACINTHS and the true PAPER WHITE GRANDIFLORA

Ask for our Wholesale Trade List at Hillegom

K. VELTHUYS, Hillegom, Holland

Rep. by FEL X EOSCH, 260 Clarendon St., Boston.

APPRAISERS' DECISION.

The protest of Wm. R. Manierre of Chicago against the assesment of duty on cypas stems has been overruled on the ground that cypas stems are properly classified as nursery stock under paragraph 252 and not as palm leaves in natural state which are free of duty under paragraph 552, tariff act of 1897.

PLANT IMPORTS.

There were entered at the port of New York during the two weeks, February 6th to February 18th inclusive, the following:—

From Rotterdam: H. F. Darrow, 5 bags garden seed; Peter Henderson & Co., 50 lags grass seed; Maltus & Ware, 13 pgs. roots and seeds, 44 pgs. seeds, 13 cs. plants; McHutchison & Co., 21 cs. do.; C. B. Richard & Co., 1 cs. do.; J. M. Thorburn & Co., 9 bgs. seed; Vaughan's Seed Store, 3 pgs. do.; Sundry Forwarders, 39 pgs. do.; 4 cs. plants, 11 cs. flower roots.

From Antwerp: McHutchison & Co., 2 cs. hulbs; Vaughan's Seed Store, 8 cs. do.; Forwarder, 1 bl. seed.

From Germany: Binghamton Seed Co., 2 cs. seed; H. F. Darrow, 1 bgs. do.; Peter Henderson & Co., 1 casik do.; Maltus & Ware, 103 pgs. do.; J. M. Thorburn & Co., 2 pgs. do.; Vaughan's Seed Store, 40 cs. lily of the valley pips, 9 bls. seed; Sundry Forwarders, 34 pgs. do.

Via Southampton: C. C. Abel & Co., 37 cs. plants; H. F. Darrow, 39 pgs. seed; Peter Henderson & Co., 20 bags seed; McHutchison & Co., 85 cs. plants; J. M. Thorburn & Co., 11 bags garden seed; Vaughan's Seed Store, 20 pgs. seed; Sundry Forwarders, 3 cs. plants, 14 pgs. seed.

Via London: Wm. Elliott & Sons, 1 bg. seed; F. C. Pollock, 7 cs. mushroom spawn, 1 bg. seed; Stumpp & Walter, 5 cs. mushroom spawn.

Via Liverpool: H. F. Darrow, 2 cs. seed; Maltus & Ware, 1 cs. trees.

From Christiania: Vaughan's Seed Store, 1 cs. seed. From Naples: 1 cs. do.

LINCOLN PANSY SEED

Blended with extra fine strains of foreign and home grown seed, giving grand rainbow colorings.

Half Trade Packet, 50 cents
Trade Packets, \$1.00

W. ELLIOTT & SONS
201 Fulton St. New York

WIBOLTT'S SNOWBALL CAULIFLOWER-SEED
Is the earliest of all Snowballs, the most compact, the surest header, is giving the largest and snow-whitest heads, and is the best keeper in dry-weather. Demand it through your seed-firm or direct from
R. WIBOLTT, NAKSKOV, DENMARK

No. 34

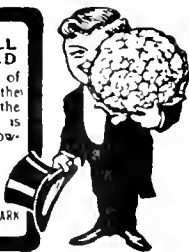

Cyclamen

Superb English Strain
Second to none in size of flowers
Giant Crimson.
" Pink
" White.
" White with Claret base.
" Mauve.
" Salmon Queen.
" New Fringed.

100 seeds \$1; 1000 seeds \$9.

H. E. FISKE SEED CO.
12 and 13 Fanueil Hall Square, - BOSTON MASS.

ESTABLISHED 1802

Thorburn's Seeds

Send for our Wholesale Catalogue of Seeds for Florists and Market Gardeners, ready in a few days.

	Per doz.	Per 100
GLADIOLUS PRIMULINUS	\$8.00	\$60.00
PRIMULINUS HYBRIDS	3.00	20.00

J. M. THORBURN & CO.
33 Barclay St., through to 38 Park Place
NEW YORK
Everything of the Highest Grade

CANNAS
A Quarter of a
MILLION
in over
FIFTY VARIETIES
(True to name)
CATALOGUES FREE
ARTHUR T. BODDINGTON
Seedsman
342 W. 14th St., NEW YORK CITY

BRIDGEMAN'S SEED WAREHOUSE

RICKARDS BROS.

Props.

37 East 19th St., - NEW YORK CITY

BRASLAN SEED GROWERS CO.

GROWERS FOR THE
WHOLESALE TRADE ONLY

SAN JOSE, - - CALIFORNIA

Burpee's Seeds

PHILADELPHIA

Blue List of Wholesale Prices mailed only to those who plant for profit.

CAULIFLOWER'S SEED CABBAGE

HJALMAR HARTMANN & CO.,
12 Stormgade,
COPENHAGEN, DENMARK.

BAMBOO CANES

TOUGH AND STRONG
6 ft. long—\$1 per 100; \$6 per 1000; \$11 per 2000

They cost about 10 per cent. more than other kinds, and they are 10 times better.

STUMPP & WALTER CO., - 50 Barclay St., New York

RELIABLE SEEDS—SOW NOW

	Fr.	6 Tr.
Alyssum Carpet Queen , real dwarf for pots only, no equal....	\$0.25	\$1.25
Begonia Gracilis Luminosa , new	0.50	2.50
Erfordia , beautiful pink...	0.30	1.50
Lobelia , new Trailing Hamburgia	1.00	5.00
Petunia , Double Fringed Giants...	0.75	4.00
Phlox , best for pots, Fireball, Roseball, Snowball, each color.....	0.25	1.25
Primula Obconica Grandiflora , new Hybrids as: Blood-red, Blue, Carmine, Pink, Purple, Violet, Pure white, Compact, Gigantea, Fringed Mixed Hybrids, each separate....	0.50	2.50

My New Price List will guide you through reliable seeds. Ask for same

O. V. ZANCEN
Seedsman. HOBOKEN, N. J.

Best Quality Fall Bulbs

It is to your advantage to place your order early. Send us a list of your wants and we will quote you rock-bottom prices. Copy of our Florists' Bulb Catalogue will be sent upon request. Catalogues now ready.

VICK'S SUPERB PANSY SEED

All the best varieties in separate colors
VICK'S SUPERB MIXTURE

the best strain from all the leading named sorts
1-8 oz. 75c. 1-4 oz. \$1.50 Ounce \$5.00

JAMES VICK'S SONS, Rochester, N. Y.

CYCLAMEN

Farquhar's Giant Strain

Unsurpassed for size of flowers.

Giant Crimson Giant Pink
Giant White Finest Mixed
Giant Excelsior, White with Claret Base

100 seeds, \$1.25; 1000 seeds, \$10.00.

R. & J. FARQUHAR & CO.
6 & 7 So. Market St., Boston, Mass.

BRECK'S SEEDS

For Farmer, Market Gardener and Florist
New Crop High Grade
Catalogues mailed free on application

Joseph Breck & Sons Corp.
47-54 NO. MARKET ST., BOSTON, MASS.

JUST ARRIVED
LARGE SHIPMENT OF
High-Grade SCOTCH SOOT.

We have the Stott Double Nozzle
THOMAS J. GREY CO.
32 & 33 So. Market St., BOSTON

G. C. MORSE & CO.

Address all communications to our permanent address
48 to 56 Jackson St., San Francisco, Cal.

The Largest Seed Growers in the United States

GLORIOUS AMERICA
GLADIOLUS
 STRONG BULBS FOR FORCING, \$60 per 1000
PHOENIX ROEBELINI
 The Jewel of all the Palms. \$4 per 100 for seedlings, \$7 per 100 in 2 inch pots.
 Complete Trade List of Florists' Forcing Gladioli, Lilies, Irises, NOW READY. 8 per cent. discount for cash with order.
JOHN LEWIS CHILDS
 FLORAL PARK, NEW YORK

Anything of Value
 to the profession
CAN BE SOLD
 through advertising in
Horticulture

THE ALASKA-YUKON-PACIFIC EXPOSITION.

The next great world's fair, the Alaska-Yukon-Pacific Exposition, will be held at Seattle, Washington, opening June 1, and closing October 15, 1909. This exposition will be held in a section of the country where world's fairs are new, and for that and many other reasons it is expected to be a success, beneficially, educationally, artistically and financially.

Work on the grounds and buildings of the exposition is well under way, and the management is determined to have everything in readiness by opening day. This has been written about all expositions in late years, but the promise has never been completely fulfilled. The officials of the Alaska-Yukon-Pacific Exposition, however, have started out with a completed-opening-day idea above everything else, and if they do not carry out their plan it will not be because western energy has not been expended in the task.

The Alaska-Yukon-Pacific Exposition promises to be different from former world's fairs in many ways, but one policy stands out so far above any of the rest that the entire press of the country is commenting favorably about it. No money will be asked from Uncle Sam to carry on the work. That policy must be conceded as original.

All the management desires is for the United States government to participate in the same manner as foreign countries, and the different States, by erecting buildings and installing exhibits therein. Former expositions have been aided by the government in many different ways. Outright gifts of large sums of money have been made by Congress to some world's fairs, while others have negotiated loans from Uncle Sam, some of which were paid back and some of which were not. Some expositions have received both donations and loans. As stated before, the Alaska-Yukon-Pacific Exposition will ask for neither. A clause pledging this policy has been inserted in the congressional bill making provision for participation only by Uncle Sam.

Since the United States government began to patronize expositions down to the Jamestown fair, Congress has appropriated a total of \$28,752,251 for world's fairs. Only \$48,999 of

this money has been spent west of the Rocky Mountains, the Lewis and Clark exposition, one of the most successful ever held, receiving the benefit of that amount.

The bill that has been introduced at the present session of Congress provides an appropriation of \$1,175,000, to enable Uncle Sam to take advantage of the opportunity for effective advertising. The money will be apportioned as follows:

	Building.	Exhibit.
Government	\$200,000	\$350,000
Alaska	100,000	200,000
Hawaii	50,000	75,000
Philippines	75,000	75,000
*Fisheries	50,000	

*The fisheries exhibit is included in the general government display.

On June 1 last before a crowd of fifteen thousand persons ground breaking ceremonies were held, with many prominent men making addresses, among whom was Hon. John Barrett, director of the International Bureau of American Republics, representing President Roosevelt. From that date to the present time work has been going on rapidly upon the exposition grounds. Most of the grading and clearing has been finished. All of the principal roadways, avenues, circles and plazas have been completed. The Administration Building has been erected and occupied by the executive force for several months. Contracts have been let for the construction of five large buildings and several small ones. Among these are the Manufactures Building, Agriculture Building, Auditorium, Palace of Fine Arts, and Machinery Hall. The three latter buildings will be permanent structures, built of buff brick with terra cotta trimmings. The "A-Y-P," as it is sometimes called in Seattle, will differ again from some former fairs in that some of its exhibit palaces will be permanent structures. The grounds are located on the property of the Washington University, a State institution, and after the exposition is over the permanent buildings and those substantially built will be taken over by the college, to be used for educational purposes.

The purpose of the exposition, which is to exploit Alaska and Yukon and the countries bordering on the Pacific ocean, is receiving much favorable comment throughout the country.

FRANK L. HERRICK.

FIRE RECORD.

The boiler house and potting shed connected with the greenhouse of J. T. Fuller, Bryantville, Mass., were completely destroyed by fire on Feb. 11. The entire stock of his three houses was killed by the cold. Loss is estimated at \$1,000; small insurance.

A rather serious fire occurred in the boiler shed of the American Rose Co.'s place on Bladensburg Road, Washington, D. C. The fire is supposed to have been caused by a stray spark. Damage amounted to about \$1,000. Fortunately the houses were intact, the only injury being done by the smoke, and damages were repaired sufficiently to fire the boiler in the open and thus save the house from freezing.

A colored plate of blooms of azalea Etoile de Somergem was sent out with a recent issue of La Tribune Horticole. The flower is large, double, and the color as shown in the plate is a bright deep crimson.

SAVE
 your weekly copies of this paper.
DON'T
 throw them away.
 The contents are always of **PERMANENT VALUE** and you may need them for reference tomorrow, a year from tomorrow, or still later.

BUY IN SEASON

Seedlings and Rooted Cuttings, extra fine, well rooted; three grades, just right for lining out: *Magnolia Glauca* (Sweet Bay), *Ampelopsis robusta purpurea* (New), *ibota Privet* (Jap.), *Berberis Thunbergia* (Jap.), *Berberis Vulgaris* (Native) *Arborvitae American* and *Siberian*, *Spruce*, *White Pine* and *Hemlock*.

It will pay you to get our prices **NOW**
PIERCE NURSERY
 BEVERLY FARMS, MASS.

LILIUM AURATUM
 9-11 \$75 per 1000
ROSEUM and RUBRUM
 9-11 \$65 per 1000
MULTIFLORUM
 7-9 \$45 per 1000

D. RUSCONI, 128 West 6th St., CINCINNATI, OH.

DREER SPECIALS

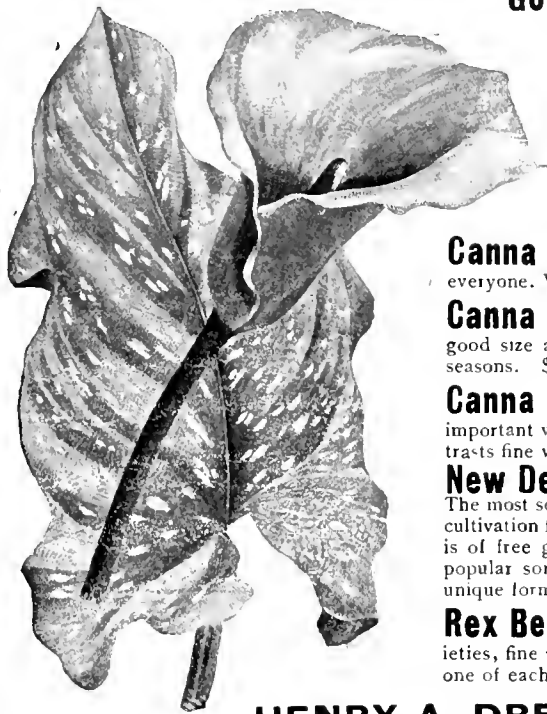

Golden Yellow Calla Elliottiana We have a fine lot of bulbs of this beautiful variety which if started into growth now can still be flowered for Easter. This Golden Calla is still but little known and always attracts attention. \$2.00 per doz., \$15.00 per 100.

Fancy Leaved Caladiums We are this season offering the finest set of Standard Fancy Leaved Caladiums that has yet been sent out at popular prices, 25 distinct sorts. \$1.50 per doz., \$10.00 per 100; the set of 25 varieties for \$3.00.

New Fancy Leaved Caladiums A set of twelve wonderfully marked beautiful varieties. The set of 12 sorts for \$2.50, or \$20 per 100.

Canna King Humbert The best of the dark leaved, very large flowered brilliant scarlets and a perfect gem that pleases everyone. We are long on this and offer at the special price of \$1.25 per doz., \$8 per 100.

Canna Grand Chancellor Bulow A remarkably rich crimson scarlet that never sunburns, with flowers of good size and very free, was much admired in our trial grounds during the past two seasons. \$1.50 per doz., \$10 per 100.

Canna Frau Marie Nagel An introduction of Wilhelm Pfitzers, the Canna specialist of Germany who has given us many important varieties. It is the most floriferous of the large creamy white sorts and contrasts fine with high-colored sorts. \$1.25 per doz., \$8 per 100.

New Decorative Dahlia Souvenir de Gustave Doazon The most sensational Dahlia of the season, of mammoth size, producing under ordinary cultivation flowers 6 inches in diameter and can be grown to measure full nine inches, it is of free growth and remarkably free flowering. Certain to become one of the most popular sorts for cutting and decorating, its pure scarlet color, immense size and unique form guarantee its future.

Rex Begonias We have at the present time the finest lot of Rex Begonias that we have been able to offer for many years, twenty distinct varieties, fine plants in 3 inch pots, \$1.25 per doz., \$8 per 100; the set of twenty sorts, one of each, for \$2.

HENRY A. DREER, 714 Chestnut St., PHILADELPHIA, PA.

BEGONIA GLOIRE DE LORRAINE

Stock plants to propagate from, or for growing on, 2½ inch and 3 inch pots, \$15.00 per 100; \$140.00 per 1000.

These are now ready for delivery.

Adiantum Farleyense

strong stock plants from 6 inch pots, good for propagating only, will average 50 eyes each.

\$6.00 per dozen.

J. A. PETERSON

McHenry Ave., Westwood, Cincinnati, Ohio.

Prices Quoted in these Columns are for Dealers Only. When Writing to Advertisers Please Mention HORTICULTURE.

GLADIOLUS BULBS

100,000, from 1¼ inches up to \$1.00 per 1000
100,000, ¾ to 1¼ inches @ \$2.00 per 1000

Cash with order. Description given on request. Nice block of California Privet, \$1.00 per 1000 and up, as to quality. Write for particulars.

Nice lot of American Chestnut Trees at a bargain. Thirty-five large Sugar trees, most of them sample trees.

I. & J. L. LEONARD, IONA, N. J.

ORCHIDS

Largest Importers, Exporters, Growers and Hybridists in the World

Sander, St. Albans, England and 235 Broadway, Room 1 NEW YORK CITY

... ORCHIDS ...

Just to hand, C. Trianae, C. labiata, C. Mossiae, C. Intermedia, C. Schroderae, C. Speciosissima, C. Citria, C. Gaskelliana, Laelia Anceps, L. Albida, L. majalis, L. Autumnalis, Epidendrum Vittelnum majus, E. Cooperianum, Oncidium Crispum, O. Varicosum, O. Cavendishianum, O. Lundum, Odonto. Citrosimum. To arrive in a short time, C. Dowiana, C. Aurea, C. Warnerii, Miltonia Vexillaria.

CARRILLO & BALDWIN SECAUGUS, N. J.

ORCHIDS for Spring Delivery

NEW IMPORTATIONS

Cattleyas, Laelias, Oncidiums, etc.

WRITE FOR PRICES

Now is the time to Pot Orchids. Best Quality of Peat, Moss and Baskets on hand.

JOSEPH A. MANDA, 191 Valley Road, WEST ORANGE N. J.

Write at once for our quotations on all

ORCHID IMPORTATIONS

FOR 1908 DELIVERY

JULIUS ROEHRS CO.,

The Orchid Nurseries, Rutherford, N. J.

ORCHIDS

We are at present booking orders for freshly imported Orchids for delivery 1908, of all leading kinds at reduced prices. We have just received the following:— Oncidium Sarcodes, O. Forbesii, O. Tigrinum and Sophronites, Grandiflora and Coccinea.

LAGER & HURRELL, Summit, N. J.

Keep Your Eye Open

FOR BARGAINS IN GOOD STOCK

See the BUYERS' DIRECTORY and READY REFERENCE GUIDE. Pages 248, 249, 250, 251, 252.

Everything offered in this paper is listed there.

Look it over before buying and, in ordering please refer to advertisement in

HORTICULTURE

ORCHIDS

The largest importation of Orchids ever received in this country WILL ARRIVE next spring from Brazil, Colombia and Venezuela. If you intend putting in stock wait for these to arrive and we will quote the Lowest Prices in America.

ORDONEZ BROS., - Madison, N. J.

JAPANESE
THE YOKOHAMA NURSERY CO. NEW YORK.
31 BARCLAY STR.
LILIES
PLANTS
BAMBOO STAKES

POINTS ON CARNATION BREEDING IN AMERICA.

Read before the joint meeting of the American Carnation Society and American Breeders' Association by C. Willis Ward, Queens, N. Y.

Though I have devoted considerable time to the breeding of carnations and to the study of them during the past fourteen years, in view of the complexity of the subject and my lack of scientific knowledge, I feel diffident in placing my views before a conference composed of the most advanced scientific talent of the world. I shall not attempt to enter into a scientific discussion of the subject, but will endeavor to state in plain language what seems to me to have been thus far accomplished.

The Original Carnation.

As most florists know, the original carnation, which has been known in history for several centuries before the Christian era, was a five-petaled single bloom one inch in diameter and of a pinkish-mauve color. It was distributed in its wild state over the whole southern half of the temperate zone in Europe, but was known more particularly to historians as inhabiting France and Northern Italy. It was found in abundance in Normandy, from whence it is generally believed to have been introduced into Great Britain about the time of the Norman Conquest. Even so recently as 1874 it was found in a wild state covering the Castle of Fallaise, in which William the Conqueror was born. It was described by Theophrastus as early as 300 B. C., and has been frequently mentioned in history since that date.

Methods of Reproduction.

The carnation of today, the subject upon which I am working, is the product of several centuries of hybridisation and culture. It is an open-pollinated species, and mother plants can be chosen from amongst hybrids, as well as by imbreeding upon the same plant or upon plants of the same variety. A variety once produced from seed is easily perpetuated for a certain period by propagation from cuttings which are easily rooted and usually secured in abundance. Improvements in varieties may be made by bud selection and new varieties are sometimes secured by bud variation (sports), as well as from seed variation and by hybridisation.

In raising varieties from hybridised seed very few improvements are produced, the proportion being one good variety for every thousand hybrids grown, and probably as little as one decided advance in each five or ten thousand hybrids grown; and unless some law is discovered whereby we can forecast more surely than we now can what certain specified hybrid seed will produce, it would seem as if even this low proportion of valuable new varieties would decrease rather than increase in view of the higher standard which is being demanded from year to year.

Working for Color Improvement.

Up to the present time I have been

pursuing my studies in breeding upon the single subject of color alone, basing my work upon the theory that any laws developed in color would hold good when applied to the development of other qualities; and this hypothesis I still believe to be correct.

The tools used are very simple, consisting only of a pair of delicate tweezers and a microscopic magnifying glass. I used to employ a fine camel's hair brush for transferring the pollen, but eventually abandoned it, as I found the use of the tweezers less difficult and speedier work could be done than with the brushes.

In hybridising the carnation the first step is to remove all the anthers from the mother flower before they develop, and to watch the pistil until it is in a proper receptive condition. The anthers of the selected male parent are watched until just bursting, and the pollen is in the condition of a dry powder. The anther is then removed by means of the tweezers and the pistil of the mother flower is fertilized by lightly touching it along its entire length with the pollen-bearing anther. Conception generally takes place within twenty-four hours after this operation, provided the conditions are favorable.

In order to pursue my color studies with reasonable method I have divided the work into the following sections:

1. Fancy section, comprising all varieties peculiarly marked, of various colors.
2. Purple and blue section, comprising all purple flowers and any which may show a tendency towards blue in color.
3. Crimson and maroon section, comprising all shades of crimson, maroon or scarlet maroon.
4. Scarlet section, comprising all shades of red and scarlet.
5. Light pink section, including all shades of salmon, flesh or daybreak tints.
6. Dark pink section, including all rose, cherry and deep pink tones.
7. White section.
8. Yellow variegated section, including all varieties having a yellow ground with scarlet, crimson or pink markings. I have not as yet been able to establish a pure yellow section, for even though the seeding plant may give pure yellow flowers for a time, as soon as propagation is carried on to any extent, more or less variegation appears.
9. White variegated section, comprising all varieties with white grounds marked with various colors.
10. Pink variegated section, comprising all varieties having a pink ground of any shade with markings in deeper colors.

In the purple and blue section I

have not as yet succeeded in producing anything that might be termed a blue; for, although we have had several varieties showing a distinct blue shade, there has invariably been enough pink in it to convert the tone into a purple or a mauve. The crimson, dark and light pink, scarlet and white sections have been fairly well fixed; but the yellow, white and pink variegated, and blue sections will be very difficult to fix, as they are essentially mosaics, and there is a constant tendency towards variation in all their progeny.

(To be Continued)

BOXWOOD

Finest quality, \$17.50 per Cwt.

GALAX Green, \$1.00 per 1000; \$7.50 per 10,000.
Bronze, \$1.00 per 1000; \$7.50 per 10,000.

Hardy Ferns, Best Grade, \$1.50 a 1000

LAUREL, MOSS, PRINCESS PINE, FESTOONING.

N. F. McCARTHY & CO. Telephone 5973-5974 Main **84 HAWLEY ST., BOSTON**
Largest Dealers in Florists' Supplies in New England

BOSTON FLORIST LETTER CO.

Manufacturers of FLORISTS' LETTERS

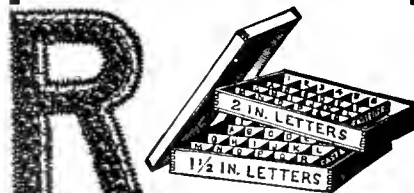

This wooden box nicely stained and varnished, 18x30x12, made in two sections, one for each size letter, given away with first order of 500 letters.

Block Letters, 1/2 or 2 inch size per 100, \$2.
Script Letters, 3. Fastener with each letter or word. Used by leading florists everywhere and for sale by all wholesale florists and supply dealers.

N. F. McCARTHY, Manager
66 Pearl Street, BOSTON, MASS.

The "Japana" Cut Flower Holder

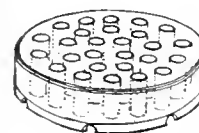

A handy article for florists. Sells to the trade on sight. Made of glass in three sizes. The "Angiels" Table Decoration, something entirely new, long needed. The florist and housewife will appreciate this article, as it simplifies the art of table decorating.

Ask for catalog.

M. V. CARNSEY, Dept. F,
130 Waiola Ave., La Grange, Ill.

KORAL SCRIPT LETTERS AND EMBLEMS

ONCE USED ALWAYS USED
For sale by all first class supply houses. Made by

KORAL MFG. CO.
26 Hawley St., Boston

E. A. BEAVEN

**Southern Wild Smilax,
Log Mosses,**

Natural and Perpetuated — at Wholesale,

EVERGREEN, ALABAMA.

JOHN BREITMEYER'S SONS

Cor. Miami and Gratiot Aves.
DETROIT, MICH.

Artistic Designs . . .
High Grade Cut Blooms

We cover all Michigan points and good sections of Ohio, Indiana and Canada

P. J. and J. E. HAUSWIRTH

232 Michigan Ave.

CHICAGO

AUDITORIUM ANNEX Tel. Harrleoon 585

SAMUEL MURRAY

Florist

Coates House Conservatory

1017 BROADWAY, KANSAS CITY, MO
Both 'Phones 2670 Mafn

FRED C. WEBER FLORIST

4326-28 ST. LOUIS, MO.
OLIVE STREET
Established 1873
Long Distance Phone Beil Lindell 676



WASHINGTON,
D. C.

GUDE'S

Geo. H. Cooke FLORIST

Connecticut Avenue and L Street
WASHINGTON, D. C.

The Park Floral Co.

J. A. VALENTINE
Pres.

DENVER, COLORADO

WILLIAM L. ROCK FLOWER CO.

KANSAS CITY, MO.

will carefully execute orders for Kansas City and any town in Missouri or Kansas.

ALBANY, N. Y.

EYRES

Flowers or Design Work

DELIVERED IN ALBANY AND VICINITY ON TELEGRAPHIC ORDER.

11 NORTH PEARL ST., ALBANY, N. Y.

CHICAGO RETAIL TRADE.

Chicago retailers report a good finish although Valentine's Day was a very disagreeable one as to weather, rain, snow and sleet falling at intervals all day. Most of the downtown stores had window displays of red heart-shaped boxes which added much to their other show of violets and spring flowers. It is to be hoped that some of the storemen will order in better season another year as the supply houses were unable to supply the demand for these boxes at the last day and many buyers got disappointed. Among the new and attractive things was a heart-shaped hamper of birch bark, neatly decorated with violet color and sold exclusively by one supply house.

The Chicago delegation to the Third Annual Convention of the Illinois State Florists' Association at Springfield, Ill., which left at 10.15 P. M., Monday, via Illinois Central train under the lead of Chairman F. F. Bentley, included Leonard Kill, George Asmus, August Poehlmann, E. F. Winterson, J. E. Jensen, J. C. Vaughan, Jas. Wilson and Fred Longren.

LEADING RETAIL FLORISTS—
Index by Towns will be found in
Buyers' Directory.



BOSTON'S BEST In Quality and Design

Can be relied upon when you transfer your retail orders to

EDWARD MACMULKIN
194 Boylston Street, Boston

Send flower orders for delivery in

BOSTON
and all
NEW ENGLAND POINTS
THOS. F. GALVIN
124 Tremont St., Boston

TRANSFER

Your orders for flower or plant delivery in Eastern New England to

JULIUS A. ZINN,
2 Beacon St., Boston.

Fine Design Work a Specialty

YALE Orders for flower deliveries to Yale College and all other Connecticut points carefully filled and delivered by

J. N. CHAMPION & COMPANY
1026 CHAPEL STREET NEW HAVEN, CONN.

ATLANTA FLORAL CO.
41 Peachtree Street. ATLANTA GEORGIA.

Florists

Out of
Town

Taking orders for delivery in
New York or Vicinity
can have them filled in best
manner and specially delivered by

Thomas Young, Jr.

500 Fifth Ave., New York City
Telephone 847 Bryant.

ALEX. McCONNELL

571 FIFTH AVENUE
NEW YORK CITY

Telegraphic orders forwarded to any part of the United States, Canada, and all principal cities of Europe. Orders transferred or intrusted by the trade to our selection for delivery on steamships or elsewhere receive special attention.

Telephone Calls, 487 and 488 38th St.
Cable Address, ALEXCONNELL

William J. Smyth FLORIST

Cor. Michigan Ave. and 31st St., CHICAGO.

We ship to all points in Illinois and Iowa.

Phones: Douglas 744, Douglas 523, Douglas 740

WILLIAM H. DONOHUE

FLORAL DECORATOR

17 East 28th St., New York

Special Attention to Theatre and Steamer Orders, and reliable deliveries guaranteed.

DAVID CLARKE'S SONS

Deliver orders from any part of the country to
New York City

Or OUT-GOING STEAMERS

Write or telegraph

2139-2141 Broadway, New York
Telephone 1552-1553 Columbus

PROMPT DELIVERY IN BOSTON

AND ALL NEW ENGLAND POINTS

HOUGHTON & CLARK
396 Boylston St., Boston, Mass.

Flower Deliveries

In Brooklyn and other Long Island Points New York City, New Jersey, etc. At Theatres, Hotels, Steamers or Residences.

WILSON

Fulton St. and Greene Ave., Brooklyn, N.Y.

YOUNG & NUGENT

42 West 28 St., NEW YORK

"FLOWERS BY TELEGRAPH"

JACOB SCHULZ, 644 Fourth Ave., LOUISVILLE, KY.

Cut Flowers of BEST QUALITY in season delivered promptly to any address.

Write, Telegraph or Telephone.

Cumberland and Home Phones 223 and 984

EASTER PLANTS

**Azaleas, Baby Ramblers,
Hydrangeas, Lilies,
Geraniums**

In fine condition. Write for Prices

WM. W. EDGAR CO., Waverley, Mass.

ACACIA PUBESCENS

A choice and seasonable specialty, long sprays of shimmering gold. Prices on application.

CHOICE VALLEY WHITE VIOLETS

\$3.00 and \$4.00 per 100 \$1.50 per 100

S. S. PENNOCK - MEEHAN CO.
1608-1620 Ludlow St. PHILADELPHIA

"The" Wholesale Florists of Philadelphia

EVERYTHING SEASONABLE IN
CUT FLOWERS

EDWARD REID, Wholesale Florist

1526 Ranstead St., PHILADELPHIA
STORE CLOSES 8 P. M.

CHAS. W. MCKELLAR

51 WABASH AVE., CHICAGO

Western Headquarters for Choice Orchids
Valley, Roses and all Cut Flowers

PETER REINBERG WHOLESALE

CUT FLOWERS

51 Wabash Av., Chicago, Ill.
In writing advertisers, mention Horticulture

CUT FLOWER BOXES

EDWARDS FOLDING BOX CO
MANUFACTURERS
PHILADELPHIA, PA.

AMERICAN BEAUTY and all other ROSES

LILY OF THE VALLEY, CARNATIONS

WELCH BROS., 226 Devonshire St., Boston, Mass.

TRUMPET MAJORS

Extra Quality Any Quantity

W. E. MCKISSICK WHOLESALE FLORIST

PHILADELPHIA
1619-1621 RANSTEAD ST.

DAILY CONSIGNMENTS

From 40 to 60 Growers

We can care for your cutflower wants to advantage.

E. F. WINTERSON CO.

46-47-49 WABASH AVE., CHICAGO

J. J. HARTY & COMPANY

WHOLESALE AND COMMISSION **FLORISTS**

3112 G Street, N. W., Washington, D. C.

WHOLESALE FLOWER MARKETS—TRADE PRICES—Per 100 TO DEALERS ONLY

	CHICAGO Feb. 17	TWIN CITIES Feb. 17	PHILA. Feb. 17	BOSTON Feb. 19
ROSES				
Am. Beauty, Fancy and Special...	40.00 to 50.00	40.00 to 50.00	40.00 to 50.00	40.00 to 50.00
" " Extra	30.00 to 40.00	30.00 to 40.00	25.00 to 30.00	12.00 to 20.00
" " No. 1	20.00 to 30.00	20.00 to 30.00	15.00 to 20.00	10.00 to 20.00
" " Lower grades	5.00 to 15.00	8.00 to 15.00	5.00 to 10.00	2.00 to 4.00
Bride, 'Maid, Extra and Special	8.00 to 12.00	8.00 to 12.00	10.00 to 15.00	8.00 to 10.00
" " Lower grades	6.00 to 7.00	6.00 to 7.00	6.00 to 10.00	5.00 to 6.00
Killarney, Richmond, Fau & Sp.	3.00 to 5.00	4.00 to 5.00	4.00 to 6.00	1.00 to 2.00
" " Lower grades	8.00 to 12.00	8.00 to 12.00	12.00 to 20.00	8.00 to 10.00
Chat-nay, Wellesley, Fau. & Sp.	4.00 to 6.00	4.00 to 6.00	3.00 to 8.00	1.00 to 5.00
" " Lower grades	4.00 to 6.00	4.00 to 6.00	4.00 to 10.00	15.00 to 6.00
Golden Gate Ivory	4.00 to 8.00	4.00 to 8.00	4.00 to 12.00	1.00 to 5.00
CARNATIONS				
Fancy and Novelties	2.00 to 3.00	2.00 to 4.00	3.00 to 6.00	1.00 to 2.00
Ordinary	1.00 to 1.50	1.50 to 2.00	1.00 to 2.00	... to .50
MISCELLANEOUS				
Violes	.50 to .75	.50 to 1.25	.25 to 1.00	.25 to .50
Cattleyas	40.00 to 50.00	40.00 to 50.00	50.00 to 60.00	25.00 to 50.00
Cypripediums	1.00 to 1.50	12.00 to 15.00	12.50 to 15.00	8.00 to 12.00
Lilies	10.00 to 12.00	10.00 to 12.00	12.00 to 15.00	8.00 to 10.00
Lily of the Valley	2.00 to 3.00	2.00 to 3.00	2.00 to 5.00	1.00 to 2.00
Freesia	2.00 to 3.00	2.00 to 3.50	1.00 to 4.00	1.00 to 2.00
Rom-a-Hy, Paper White Nar.	1.00 to 3.00	2.00 to 3.00	1.00 to 3.00	1.00 to 2.00
Daffodils	2.00 to 3.00	2.00 to 3.00	1.50 to 4.00	1.00 to 1.50
Tulips	2.00 to 4.00	2.00 to 4.00	2.00 to 6.00	1.00 to 2.00
Mignonette	6.00 to 8.00	4.00 to 8.00	1.50 to 5.00	3.00 to 4.00
Gardenias	35.00 to 50.00	35.00 to 50.00	30.00 to 60.00	25.00 to 40.00
Lilac per bunch	1.50 to to 1.50	.50 to 2.00	1.00 to 1.50
Sweet Peas	.50 to 1.00	.50 to 1.00	.35 to 1.50	50 to 1.00
Achantum	.75 to 1.00	.75 to 1.00	1.00 to 1.50	1.00 to 1.50
Whitmanii Frouds to to	2.00 to 4.00	3.00 to 5.00
Smilax	12.00 to 15.00	12.00 to 15.00	12.00 to 20.00	10.00 to 12.00
Asparagus Plumosus, striggs	35.00 to 50.00	35.00 to 50.00	50.00 to 75.00	25.00 to 50.00
" " & Spreng. (100 behs) to 35.00 to 35.00	0.00 to 7.00	2.00 to 50.00

THE FLORISTS' SUPPLY HOUSE OF AMERICA

Without a rival in knowledge of the requirements of the trade and the ability to supply them. Our New Illustrated Catalogue, recognized as a work of art unprecedented in its line for variety, novelty and completeness, tells the story fully, and if you have not yet sent for it, do so now.

'TIS FREE TO EVERYBODY IN THE TRADE

H. BAYERSDORFER & CO., 1129 Arch St., Philadelphia, Pa.

FLOWER MARKET REPORTS

BOSTON We should like to be able to report some improvement over the sluggish and unsatisfactory conditions recorded for the previous week, but there is nothing to warrant such. Demand has not increased any and supply, which it was hoped might slacken up, continues to increase. Roses are now in the same condition of over-supply that carnations have been experiencing, and indications are for a still heavier overstock. Bulbous stock is, if possible, in worse straits than ever before. Yellow narcissi are splendid as to quality but that does not appear to help them to move any faster. Altogether, the market is disappointingly slow.

Trade has been very un-
BUFFALO even, one day a flurry and the next two no life at all. St. Valentine's day was quite lively and the demand was more brisk, especially in the violet and rose line, but as for carnations there were enough to go around a number of times and at prices ridiculous for the month of February, although of good quality generally. The keeping quality has not been of the best, a result attributed to the changeable weather. Roses are none too plentiful and have cleaned up well. Beauties are coming in only normal supply and selling rapidly; also Richmonds, Killarneya and other teas, and prices holding firm. Narcissi overloaded. Spring stock sold better than in previous week. Adiantum and other greens in good supply.

The past week, being
CHICAGO so-called "Cupid Week," had a tendency to rush business somewhat with the shipping trade. It was very good, a great many violets as well as other flowers being sent out. Roses still hold up at fair prices, Beauties not being so plentiful and bringing better figures. Carnations, first class stock, have held up well but second class stuff is being sold at any price obtainable. Lily of the valley is selling well as also are orchids. Bulbous stock is still on the decline.

Your correspondent is
DETROIT forced to idleness through a broken collarbone. On the same day his mishap occurred Chas. Warnke of Woodmere broke his left leg. The bones of both unfortunates are beginning to heal nicely. Although the weather was anything but favorable to business, Valentine's Day nevertheless brought forth a healthy increase in the flower business. Everybody was very busy that day while several banquets and the arrival of Secretary Wm. H. Taft caused considerable hustling most of the week. Prices are maintained at good healthy figures with carnations crowding the market to some extent.

Trade conditions
INDIANAPOLIS for the past week have been no better. Bulbous stock is more than enough; carnations are also coming in a little stronger, red having the slowest sale, and there are roses enough to go around. Valentine's Day was not up to last year. Violets took the lead.

There is no improve-
NEW YORK ment in market conditions here and none in sight. The abundant supply of carnations and bulbous stock makes clearances difficult, and when effected it is at low figures. The cut of tea roses is not heavy but the demand is so uneven that fixed quotations are out of question and, with cheap carnations in competition, prices are depressed. American Beauties are in light supply still and the price for them is fairly steady. Cattleyas are bringing more money now as a result of a lighter crop. Lily of the valley is doing fairly well at the present writing. Of freezias, sweet peas, daisies, Harrisii and forget-me-nots there is a plenty, going at all sorts of prices according to quality. Supply and demand are about equal as regards smilax and asparagus. To sum up the situation, it may be said that the market is supplied with more stock than can be moved daily and trade is dull.

Three bad days
PHILADELPHIA followed by three good. The bad on account of cold weather and lack of demand, the good because of a rise in temperature and St. Valentine. The rise in temperature let the fakirs out, and St. Valentine called for violets in immense quantities, also welcomed red roses, sweet peas, myosotis and Paris daisies. The carnation was probably the worst sufferer of the week but American Beauty was not far behind. The area under cultivation both for Beauties and carnations is much larger in this vicinity than ever before, and the demand for these and everything else is away below normal. Richmond roses were a fairly satisfactory proposition, also Liberty. Brides sold well but at reduced prices. Fancy Bridesmaids brought good prices but the great bulk, being under grade, suffered severely. Daffodils never so plentiful; too much of all kinds of bulbous flowers. Orchids clean up well—perhaps on account of being off crop. Asparagus, plumosus and smilax find a satisfactory market.

Improved condi-
WASHINGTON tions are apparent in the flower market and several of the retailers are more than rushed. Prices are still normal and there is every reason to believe that they will continue so until Lent begins, for there are numberless gaities to be crowded into the next two weeks.

BUSINESS CHANGES.

Max R. Englemann has withdrawn from the firm of R. Englemaun & Son, of Pittsfield, Mass.

Miss Lizzie Miller, who was formerly connected with the Mt. Hope Floral Co., is manager of the New Floral Co., at 65 Hammond street, Bangor, Me.

The Holloway Seed and Floral Co. will hereafter be known as the Robinson Seed and Plant Co., Dallas, Texas.

A. Peterson and S. E. Lawrence, two well known florists of Hoopston, Ill., have combined their interests, and the firm name will be Peterson & Lawrence.

INCORPORATED.

Minge Floral Co., Mobile, Ala.; Maria Minge, Windham Lyon, W. M. Bailey; capital, \$20,000.

The Guthrie-Lorenz Company opened a new flower store at 420 Sixth Ave., Des Moines, Ia., on February 10.

A. J. Fellouris Co., New York, wholesale florists; A. J. Fellouris, S. J. Loupy, G. G. Malhami; capital, \$5,000.

McKay Nursery & Floral Co., Jackson, Miss.; A. B. McKay, R. L. Atkinson, J. T. Dameron, J. T. McKay; capital, \$20,000.

Rapp Horticultural Building Co., New York; to manufacture greenhouses, etc.; Roy I. Rapp, W. J. McCormick, W. C. Lange; capital, \$10,000.

Earp-Thomas Farmogerm Co., Jersey City, N. J.; to manufacture and sell certain nitrogen gathering organisms or bacteria for use in inoculating plants, seeds or soil; J. A. Graves, E. J. Pierce, A. H. Trimmel, J. S. Gormley, L. W. Kennedy; capital, \$180,000.

Mr. Louis Boeglin, head gardener at the Park greenhouses, Minneapolis, has returned from a trip abroad, bringing a nice collection of plants in varieties which had been used in bedding in Europe, but have not yet been well introduced into this country. Among these are some fuchsias, geraniums, begonias, verbenas, variegated solanums, etc. He reports that conditions for employes abroad are better than they ever were. Wages have risen considerably, and the men that have their board with the employers are better taken care of than before. The working hours are reduced to nine hours in landscape and ten hours in the other branches.

In ordering goods please add, "I saw it in HORTICULTURE."

J. B. Murdoch & Co.

Wholesale Florists

FLORISTS' SUPPLIES

714 Penn Ave., PITTSBURG, PA.

Long Distance Phone 1435 Court.

J. KOPELMAN & CO.

Wholesale Dealers in

Cut Flowers and Florists' Supplies
EVERGREEN AND FERN LEAVES

OF ALL KINDS.

21 Washington St., PROVIDENCE, R. I.

Telephone Connection.

ROBERT J. DYSART,

Public Accountant and Auditor

Simple methods of correct accounting especially adapted for florists' use.

Books Balanced and Adjusted

Merchants Bank Building

28 STATE ST., - BOSTON

Telephone, Main 38

The KERVAN CO. 113 W. 28th ST. New York

WHOLESALE DEALERS

Fresh cut Palmetto & Cycas Palm Leaves, Galax, Leucothoe, Ferns and Mosses. All Decorating Evergreen

JOHN YOUNG
WHOLESALE FLORIST
 Finest American Beauties and Carnations
 51 West 28 St. - NEW YORK

FORD BROTHERS
 48 West 28th Street, NEW YORK
FINE ROSES FANCY CARNATIONS
 A Full Line of All CUT FLOWERS
 Telephone, 3870 or 3871 Madison Square

H. E. FROMENT,
 Wholesale Commission Florist,
 Choice Cut Flowers,
 57 West 28th St., :: NEW YORK.
 Telephones: 2200, 2201, Madison Square.

The Reliable Commission House
 Richmond Roses and Rich Flowers
 of all varieties
JOS. S. FENRICH
 110 W. 28th Street, New York
 Tel. 334-325 Madison Square

Established 1891 BUY FROM SHIP TO TRY **ME**
ALFRED H. LANGJAHR
 All Choice Cut Flowers in Season
 55 West 28th St., New York
 Telephone 3924 Madison Square.

JOHN I. RAYNOR
Wholesale Commission Florist SELLING AGENT FOR LARGEST GROWERS
 A full line of Choice Cut Flower stock for all purposes. Comprises every variety grown for New York market, at current prices
 TEL. 1998 MADISON SQUARE 49 W. 28 St., New York City

Walter F. Sheridan
 Wholesale Commission Dealer in
CHOICE CUT FLOWERS
 39 West 28th Street, New York
 Telephone: 3532-3533 Madison Square

HEADQUARTERS FOR NOVELTIES
ORCHIDS A SPECIALTY
 THE HIGHEST GRADE OF **VALLEY** ALWAYS ON HAND
 GARDENIAS, DAISIES, ROSES AND CARNATIONS
JAMES McMANUS, Telephone 753 Mad. Sq. 42 W. 28th St., New York

PHILIP F. KESSLER 55 & 57 W. 26th St., New York City
 Commission Dealer, Wholesale Buyer and Seller of
CUT FLOWERS
 Open from 5 a. m. to 6 p. m. Sunday till 10 a. m.
 Tel., 5243 and 2921 Madison Sq. Res., 345 J., Newtown.
Finest Lilies in the Market Every Day in the Year.

WHOLESALE COMMISSION FLORIST **J. K. ALLEN** 106 W. 28 ST. NEW YORK
 OPEN 6 A.M. DAILY Telephone 167 Madison Sq.
 We have a good regular outlet for seasonable flowers

NEW YORK QUOTATIONS PER 100—TO DEALERS ONLY

	Last Half of Week ending Feb. 15 1903	First Half of Week beginning Feb. 17 1903		Last Half of Week ending Feb. 15 1903	First Half of Week beginning Feb. 17 1903
Roses			Cattleyas	25.00 to 50.00	25.00 to 50.00
Am. Beauty, fan and sp.	40.00 to 50.00	40.00 to 50.00	Cyripediums	6.00 to 8.00	6.00 to 8.00
" extra	10.00 to 15.00	10.00 to 15.00	Lilies	6.00 to 10.00	6.00 to 10.00
" No. 1	8.00 to 12.00	8.00 to 12.00	Lily of the Valley	1.00 to 2.00	1.00 to 2.00
" Lower grades	1.00 to 2.00	1.00 to 2.00	Freesia	1.00 to 2.00	1.00 to 2.00
Bride, 'Mald, fan and sp.	6.00 to 10.00	6.00 to 10.00	Roman Hy., Paper White Nar.	1.00 to 2.00	1.00 to 2.00
" extra to 5.00 to 5.00	Daffodils	1.00 to 1.50	1.00 to 1.50
" lwr. grds.	1.00 to 2.00	1.00 to 2.00	Tulips	1.00 to 2.00	1.00 to 2.00
Killarney, Richmond, fancy & spec	6.00 to 10.00	6.00 to 10.00	Algonette	2.00 to 4.00	2.00 to 4.00
" lower grades	1.00 to 2.00	1.00 to 2.00	Gardenias	13.00 to 25.00	10.00 to 25.00
Chatenay, Wellesley, fan. and spec.	6.00 to 10.00	6.00 to 10.00	Lilac per bunch to .75 to .75
" lower grades	1.00 to 2.00	1.00 to 2.00	Sweet Peas	.50 to .75	.50 to .75
Golden Gate, Ivory	1.00 to 6.00	1.00 to 6.00	Adiantum	.75 to 1.50	.75 to 1.50
Carnations, Fancy and Novelties	1.00 to 2.00	1.00 to 2.00	Smilax	8.00 to 10.00	8.00 to 10.00
" Ordinary to .50 to .50	Asparagus Plumosus, strings	25.00 to 40.00	25.00 to 40.00
Violets	.25 to .25	.25 to .25	" " & Spreo. (100 bchs.)	10.00 to 15.00	10.00 to 15.00

B. S. SLINN, Jr.
 —WHOLESALE FLORIST—
 55 & 57 W. 26th St., New York City
 Tel., 3364 Madison Sq. Shipping Orders Solicited.
VIOLETS Roses and Carnations

TRAENDLY & SCHENCK
WHOLESALE FLORISTS
 Furnish best stock at fair prices all the year round Send for quotations on fall orders
 Tel. 798.799 Madison Sq. 44 West 28th Street, New York City

Edward C. Horan
Wholesale Florist
 55 WEST 28th ST.
 Tel. 1462 1463 Madison Square New York

Alexander J. Guttman
THE WHOLESALE FLORIST OF NEW YORK
 43 WEST 28th STREET
 PHONES. 1664--1665 MADISON SQUARE
ENOUGH SAID



HARDY CUT FERNS

Sphagnum Moss, Extra Large Bales, per bale, \$1.25. Fancy and Dagger Ferns our specialty. A trial order will convince you that we ship only first-class stock. Headquarters for Florists' supplies and wire work. All cut flowers in season. **BOXWOOD**, per bunch 35c, 50 lbs. \$7.50.

MICHIGAN CUT FLOWER EXCHANGE, INC.,

All 'phone connections

38-40 Broadway, Detroit, Mich.

FRANK S. HICKS & CO.
Wholesale Florists.

Open Now for Consignments of Cut Flowers.
52 West 28th Street, - New York City
Tel. 2920 Mad. Sq.

FRANK MILLANG
Wholesale Florist

Telegraphic Orders Filled and Delivered.
55-57 West 26th St., New York City.

Headquarters in Western New York

FOR
ROSES, CARNATIONS

And all kinds of Seasonable Flowers

Wm. F. Kasting Co.

Wholesale Commission Florist, also Dealer in Florists' Supplies and Wire Designs.

383-87 ELLICOTT ST. BUFFALO, N. Y.

Give us a trial. We can please you.

Best Flowers

IN THE
BOSTON MARKET

N. F. McCarthy & Co.

84 Hawley St., BOSTON, MASS.

Send for Prices

SAMUEL A. WOODROW

WHOLESALE PLANTSMAN

Palms, Large and Small Ferns, etc.
53 West 30th Street, NEW YORK

Telephone 2083 Madison

WILLIAM H. KUEBLER

Brooklyn's Foremost and Best

WHOLESALE COMMISSION HOUSE

A First Class Market for all CUT FLOWERS

28 Willoughby St., Brooklyn, N. Y.

Tel. 4591 Main

CLEARY'S HORTICULTURAL CO.

Management AMBROSE T. CLEARY

Wholesale Contracting, Jobbing, Auction

HORTICULTURAL PRODUCTS

of every description.

Consignments Received. Surplus Stock Converted.

62 Vesey St., NEW YORK

Moore, Hentz & Nash,

Wholesale Commission Florists,

55 and 57 West 26th Street,

Telephone No. 756
Madison Square.

New York.

HENRY M. ROBINSON & CO.

Wholesale and Commission
FLORISTS

Hardy Cut Evergreens and Florists' Supplies

15 Province St. and 9 Chapman Place,
BOSTON, MASS.

WHOLESALE FLOWER MARKETS. — PER 1000 TO DEALERS ONLY.

	CINCINNATI Feb. 18	DETROIT Feb. 18	BUFFALO Feb. 18	PITTSBURG Feb. 18
ROSES				
Am. Beauty, Fan. and Sp.	25.00 to 30.00	40.00 to 50.00	40.00 to 50.00	40.00 to 50.00
" Extra	10.00 to 15.00	25.00 to 35.00	20.00 to 30.00	25.00 to 35.00
" No. 1	4.00 to 6.00	5.00 to 25.00	10.00 to 15.00	16.00 to 15.00
" Lower grades	8.00 to 10.00	8.00 to 10.00	5.00 to 10.00 to 6.00
Bride, 'Maid, F. & S.	8.00 to 10.00	10.00 to 12.00	10.00 to 15.00	10.00 to 12.00
" Extra	6.00 to 8.00	8.00 to 10.00	8.00 to 10.00 to 8.00
" Low. gr.	4.00 to 5.00	5.00 to 6.00	4.00 to 6.00 to 6.00
Killarney, Richmond, Fan. & Sp.	8.00 to 10.00	6.00 to 8.00	10.00 to 15.00	10.00 to 12.00
" Lower grades	4.00 to 6.00	4.00 to 6.00	6.00 to 10.00	6.00 to 10.00
Chatenay, Wellesley, Fan. & Sp.	8.00 to 10.00	6.00 to 8.00	12.00 to 15.00	8.00 to 12.00
" Lower grades	4.00 to 6.00	4.00 to 6.00	6.00 to 10.00 to 6.00
Golden Gate, Ivory	6.00 to 8.00	4.00 to 8.00	4.00 to 10.00	6.00 to 8.00
CARNATIONS				
Fancy and Novelties	3.00 to 4.00	3.00 to 4.00	3.00 to 4.00	3.00 to 4.00
Ordinary	1.50 to 2.00	1.00 to 2.00	2.00 to 3.00	1.50 to 2.00
MISCELLANEOUS				
Violets	50 to .75	.50 to .75	.50 to 1.00	.25 to .75
Cattleyas	40.00 to 50.00	40.00 to 50.00 to	50.00 to 75.00
Cypripediums	12.00 to 15.00	12.00 to 15.00	10.00 to 15.00 to 15.00
Lilies	12.00 to 15.00	10.00 to 15.00	4.00 to 15.00	12.50 to 15.00
Lily of the Valley	3.00 to 4.00	3.00 to 4.00	3.00 to 4.00	3.00 to 4.00
Freesia	3.00 to 4.00	2.00 to 4.00	2.00 to 3.00	3.00 to 4.00
Roman Hy., Paper White Nar.	2.00 to 3.00	2.00 to 3.00	2.00 to 3.00	1.50 to 3.00
D. flodils.	2.00 to 4.00	2.00 to 4.00	3.00 to 3.50	3.00 to 4.00
Tulips	1.00 to 4.00	3.00 to 4.00	2.00 to 3.00	2.00 to 3.00
Mignonette	6.00 to 8.00	4.00 to 8.00	3.00 to 5.00	3.00 to 6.00
Gardenias	35.00 to 50.00	35.00 to 50.00	5.00 to 1.00 to
Lilac p. r. buach. to 1.50 to 1.00 to 1.00	.75 to 1.00
Sweet Peas	50 to .75	50 to 1.00 to25 to 1.25
Adiantum to 1.00 to 1.00 to	1.00 to 1.25
Whitmanii Froeds. to to to to
Smilax to 12.50 to 15.00 to 15.00	10.00 to 12.50
Asparagus Plumosus, strings.	40.00 to 50.00	40.00 to 50.00	50.00 to 60.00	30.00 to 50.00
" " & Spren (100 bchs.)	25.00 to 35.00	25.00 to 35.00	25.00 to 50.00	30.00 to 60.00

H. C. BERNING

Wholesale Florist

1402 Pine Street, ST. LOUIS, MO.

Alex Mann, Jr. Co., Inc.

Wholesale Dealer in
Florists' Supplies and Cut Flowers
White Doves, \$9.00 per doz.
Galax Leaves.

1125 Polk Street, San Francisco, Cal.

A. MOLTZ

Will purchase flowers on order in N. Y. market and ship carefully at prevailing wholesale prices. Address

55-57 West 26th Street, New York City

REED & KELLER
122 West 25th St., New York

Florists' Supplies

We manufacture all our
Metal Designs, Baskets, Wire Work & Novelties
and are dealers in
Glassware Decorative Grooves and Florists' Requisites.

In writing to Advertisers kindly mention Horticulture

Buyer's Directory and Ready Reference Guide

Advertisements under this head, one cent a word. Initials count as words.

Regular advertisers in this issue are also listed under this classification without charge. Reference to List of Advertisers will indicate the respective pages.

Buyers failing to find what they want in this list will confer a favor by writing us and we will try to put them in communication with reliable dealers.

ACCOUNTANT

R. J. Dysart, 28 State St., Boston.
For page see List of Advertisers.

ALTERNANTHERAS

Red Alternantheras at 40 cents per 100.
C. W. Moeckel, 17 Summer St., Fitchburg, Mass.

ARAUCARIAS

Godfrey Aschmann, 1012 Ontario St., Philadelphia, Pa.
For page see List of Advertisers.

ASPARAGUS

Asparagus Plumosa, 2 in. pots. Fine plants, \$3.00 per 100; \$25.00 per 1000. Cash with order or good reference. Erie Floral Co., Erie, Pa.; or, Wm. F. Kasting Co., 385 Elliott St., Buffalo, N. Y.

AUCTION SALES

Cleary's Horticultural Co., 62 Vesey St., New York.
Horticultural Products of Every Description.

For page see List of Advertisers.

Sales every Tuesday and Friday. If you cannot attend send bids and shipping instructions. Catalogues on application. N. F. McCarthy & Co., 84 Hawley St., Boston.

AZALEAS

A. Leuthy & Co., Perkins St. Nurseries, Roslindale, Mass.
For page see List of Advertisers.

W. W. Edgar Co., Waverley, Mass.
For page see List of Advertisers.

August Rolker & Sons, New York, 31 Barclay St., or P. O. Box 752.
For page see List of Advertisers.

BAMBOO CANES

Stump & Walter Co., 50 Barclay St., New York.
For page see List of Advertisers.

Yokohama Nursery Co., 31 Barclay Street, New York.
For page see List of Advertisers.

BAY TREES.

Specimens and palms, all sizes. Send for prices. N. F. McCarthy & Co., 84 Hawley St., Boston.

Bay Trees and Box Trees, standards and pyramids. All sizes. Price list on application. J. Roehrs Co., Rutherford, N. J.

BOILERS

BOILERS. "Burnham" Boilers made for greenhouse heating. Lord & Burnham, 1133 Broadway, N. Y.

BOXWOOD

A. Leuthy & Co., Perkins St. Nurseries, Roslindale, Mass.
For page see List of Advertisers.

Henry M. Robinson & Co., 15 Province St., Boston.
For page see List of Advertisers.

N. F. McCarthy & Co., 84 Hawley St., Boston, Mass.
For page see List of Advertisers.

BUILDING MATERIAL

BUILDING MATERIAL of all description for All Cypress, Semi-Iron, Iron Frame or Truss Houses. Hot Bed Sash and Frames. Lord & Burnham Co., 1133 Broadway, N. Y.

BULBS AND TUBERS

Joseph Breck & Sons, 47-54 N. Market St., Boston.
For page see List of Advertisers.

J. M. Thornburn & Co., 33 Barclay St., New York.
For page see List of Advertisers.

A. T. Boddington, 342 W. 14th St., N. Y.
For page see List of Advertisers.

Rickards Bros., 37 East 19th St., New York.
For page see List of Advertisers.

H. F. Mitchell Co., Philadelphia.
For page see List of Advertisers.

H. E. Fliske Seed Co., Faneuil Hall Sq., Boston.
For page see List of Advertisers.

James Vick's Sons, Rochester, N. Y.
Fall Bulbs.
For page see List of Advertisers.

D. Rusconi, 128 W. Sixth St., Cincinnati, O.
Lilium Auratum, Roseum, Multiflorum.
For page see List of Advertisers.

Aug. Rolker & Sons, 31 Barclay St., New York.
Seasonable Import Plants and Bulbs.
For page see List of Advertisers.

K. Velthuys, Hillegom, Holland,
Represented by Felix Bosch, 260 Clarendon St., Boston.

Bulbs French and Dutch.
For page see List of Advertisers.

Dwarf Pearl tuberose, 50,000 No. 2, very fine bulbs, 4 in. in circumference. Write for prices. T. V. Rivenbark, Wallace, N. C.

CANNAS

The Conard & Jones Co., West Grove, Pa.
For page see List of Advertisers.

A. T. Boddington, 342 W. 14th St., New York.
For page see List of Advertisers.

Good Robusta, dark-leaved, at \$1.50 per 100; large clumps Burbank, Mille, Berat and Cinnebar, at \$2.00 per 100; Pennsylvania, at \$2.50 per 100. C. W. Moeckel, 17 Summer St., Fitchburg, Mass.

CARNATIONS

F. Dorner & Sons Co., Lafayette, Ind.
For page see List of Advertisers.

S. S. Skidelsky, 1741 N. 18th St., Philadelphia.
For page see List of Advertisers.

Chicago Carnation Co., Joliet, Ill.
For page see List of Advertisers.

F. R. Pierson Co., Tarrytown, N. Y.
Winsor and White Enchantress Rooted Cuttings.
For page see List of Advertisers.

H. A. Jahn, New Bedford, Mass.
Carnation Lloyd.
For page see List of Advertisers.

F. H. Kimberly, 631 Townsend Ave., New Haven, Conn.
For page see List of Advertisers.

John E. Haines, Bethlehem, Pa.
Carnations Imperial and Pink Imperial.
For page see List of Advertisers.

A. N. Pierson, Cromwell, Ct.
Carnation Winsor.
For page see List of Advertisers.

CARNATIONS—Continued

The Leo Niessen Co., 1209 Arch St., Philadelphia, Pa.
For page see List of Advertisers.

Charles H. Totty, Madison, N. J.

Fair Maid Carnation cuttings, strong, \$1.75 per 100; 500 for \$8.00.

Send for list of the best carnation cuttings. Wm. Ehmann, Jr., Corfu, N. Y.

Unrooted Lawson, Boston Market, \$5.00 per 1000; Hill, \$4.00 per 1000. Wm. Ehmann, Jr., Corfu, N. Y.

Carnation cuttings of all the leading varieties at the same price as any reliable firm. Write for prices before you look elsewhere. Wm. F. Kasting Co., 383 Elliott St., Buffalo, N. Y.

CHRYSANTHEMUMS

W. W. Edgar Co., Waverley, Mass.
For page see List of Advertisers.

CONIFERS

John Waterer & Sons, Ltd., American Nursery, Bagshot, Eng.
For page see List of Advertisers.

Write for prices on all choice ornamental conifers. N. F. McCarthy & Co., 84 Hawley St., Boston, Mass.

CUT FLOWER BOXES.

Edwards Folding Box Co., Philadelphia.
For page see List of Advertisers.

Folding cut flower boxes, the best made. Write for list. Holton & Hunkel Co., Milwaukee, Wis.

DAHLIAS

David Herbert & Son, Atco, N. J.
For page see List of Advertisers.

J. L. Moore, Northboro, Mass.
For page see List of Advertisers.

DECORATIVE PLANTS

A. Leuthy & Co., Roslindale, Mass.
For page see List of Advertisers.

EVERGREENS

The New England Nurseries, Bedford, Mass.
For page see List of Advertisers.

FERNS

A. Leuthy & Co., Roslindale, Mass.
For page see List of Advertisers.

H. H. Barrows & Son, Whitman, Mass.
Nephrolepis Whitmanii.
For page see List of Advertisers.

Godfrey Aschmann, 1012 Ontario St., Philadelphia, Pa.
For page see List of Advertisers.

John Scott, Brooklyn, N. Y.
For page see List of Advertisers.

Baur Floral Co., Erie, Pa.
For page see List of Advertisers.

Whitman ferns, 9 in., \$1.00; 8 in., 80c. H. Ernest & Son, Washington, Mo.

Nephrolepis Exaltata Bostoniensis, fine young plants, \$10.00 per 1000.

N. Elegantissima, young plants \$15.00 per 1000. Send for price list. Soar Bros., Little River, Fla.

For List of Advertisers See Page 252

FERTILIZERS

Pulverized Manure Co., 31 Union Stock Yards, Chicago, Ill.
 Wizard Brand Cattle Manure.
 For page see List of Advertisers.
 Thos. J. Grey & Co.,
 32 and 33 South Market St., Boston.
 High-Grade Scotch Soot.
 For page see List of Advertisers.

FLORAL PHOTOGRAPHS

Floral Photographs. Foley's 226-228 1-2 Bowery, New York.

FLORISTS' LETTERS.

Boston Florist Letter Co., 68 Pearl St., Boston, Mass.
 For page see List of Advertisers.
Koral Mfg. Co., 26 Hawley St., Boston.
 For page see List of Advertisers.

FLORISTS SUPPLIES

H. M. Robinson & Co., 15 Province St. and 9 Chapman Pl., Boston, Mass.
 For page see List of Advertisers.
The Kevan Co., 113 W. 28th St., N. Y.
 Decorative Evergreens.
 For page see List of Advertisers.
Reed & Keller, 122 W. 25th St., New York.
 For page see List of Advertisers.
J. B. Muddoch & Co., 714 Penn Ave., Pittsburgh, Pa.
 For page see List of Advertisers.
H. Bayersdorfer & Co., 1129 Arch St., Philadelphia.
 For page see List of Advertisers.
Alex. Mann, Jr., Co., 1125 Polk St., San Francisco, Calif.
 For page see List of Advertisers.

FLOWERS BY TELEGRAPH

Park Floral Co., Denver, Colo.
 For page see List of Advertisers.
J. N. Champlou & Co., 1026 Chapel St., New Haven, Conn.
 For page see List of Advertisers.
George H. Cooke, Washington, D. C.
 For page see List of Advertisers.
Gude Bros. Co., 1214 F St., Washington, D. C.
 For page see List of Advertisers.
Atlanta Floral Co., Atlanta, Ga.
 For page see List of Advertisers.
P. J. & J. E. Hanswirth, 232 Michigan Ave., Chicago.
 For page see List of Advertisers.
William J. Smyth, Michigan Ave. and 31st St., Chicago.
 For page see List of Advertisers.
Jacob Schulz, 644 4th Ave., Louisville, Ky.
 For page see List of Advertisers.
Thos F. Galvin, 124 Tremont St., Boston.
 For page see List of Advertisers.
Julius A. Zinn, 2 Beacon St., Boston.
 For page see List of Advertisers.
Houghton & Clark, 396 Boylston St., Boston.
 For page see List of Advertisers.
Sidney Hoffman, 59-61 Massachusetts Ave., Boston.
 For page see List of Advertisers.
J. Breitmeyer's Sons, Miami and Gratiot Aves., Detroit, Mich.
 For page see List of Advertisers.
Samuel Murray, 1017 Broadway, Kansas City, Mo.
 For page see List of Advertisers.
Wm. L. Rock Flower Co., 1116 Walnut St., Kansas City, Mo.
 For page see List of Advertisers.
Fred C. Weber, 4326-28 Olive St., St. Louis, Mo.
 For page see List of Advertisers.
H. G. Eyres, 11 N. Pearl St., Albany, N. Y.
 For page see List of Advertisers.

FLOWERS BY TELEGRAPH—

Continued

David Clarke's Sons, 2139-2141 Broadway, New York.
 For page see List of Advertisers.
W. H. Donohoe, 17 E. 28th St., New York.
 For page see List of Advertisers.
Alex. McCounell, New York.
 For page see List of Advertisers.
Robert G. Wilson, Fulton St. & Greene Av., Brooklyn, N. Y.
 For page see List of Advertisers.
Thomas Young, Jr., 500 Fifth Ave., N. Y.
 For page see List of Advertisers.
Young & Nugeut, 42 W. 28th St., N. Y.
 For page see List of Advertisers.

FLOWER POTS

W. H. Ernest, 28th and M Sts., Washington, D. C.
 For page see List of Advertisers.
A. H. Hews & Co., Cambridge, Mass.
 For page see List of Advertisers.
Hilfinger Bros., Ft. Edward, N. Y.
 For page see List of Advertisers.

Paper pots for all early vegetables. Two inch pots \$1.00 a thousand; three inch \$1.25; four inch \$1.60. P. B. Crosby, Catonsville, Md.

GALAX

Michigan Cut Flower Co., 38 and 40 Broadway, Detroit, Mich.
 For page see List of Advertisers.
 Finest green and bronze Galax in any quantity at lowest figures. N. F. McCarthy, 84 Hawley St., Boston.
 For page see List of Advertisers.

GERANIUMS

R. Vincent Jr. & Sons Co., White Marsh, Md.
 New and Standard Varieties.
 For page see List of Advertisers.

GLADIOLI

Arthur Cowee, Meadowvale Farm, Berlin, New York.
 For page see List of Advertisers.
J. L. Moore, Northboro, Mass.
 For page see List of Advertisers.
 Gladioli. Write for leaflet. B. Hammond Tracy, Cedar Acres, Wenham, Mass.
 Gladioli. Named varieties and mixtures. Send for list. E. E. Stewart, Rives Junction, Mich.

GLASS

Boston Plate & Window Glass Co., Boston.
 For page see List of Advertisers.
Standard Plate Glass Co., 26-30 Sudbury St., Boston.
 For page see List of Advertisers.
S. Jacobs & Sons, 1365-79 Flushing Ave., Brooklyn, N. Y.
 For page see List of Advertisers.
Metropolitan Material Co., 1398-1408 Metropolitan Ave., Brooklyn, N. Y.
Foley Mfg. Co., between Western Ave. and 26th St., Chicago, Ill.
GLASS, High Grade, Double Thick Greenhouse Glass. Lord & Burnham, 1133 Broadway, N. Y.

GLAZING POINT

H. A. Dreer, Philadelphia, Pa.
 For page see List of Advertisers.
GLAZING POINTS, Lord & Burnham Special Glazing Nails (Points). Lord & Burnham, 1133 Broadway, N. Y.

GREENHOUSE BUILDING MATERIAL.

Lord & Burnham Co., 1133 Broadway, New York.
 For page see List of Advertisers.
Pierson U-Bar Co., 1 Madison Sq., N. Y.
 For page see List of Advertisers.
Hitchings & Co., 1170 Broadway, N. Y.
 For page see List of Advertisers.
A. T. Stearns Lumber Co., Neponset, Boston.
 For page see List of Advertisers.
King Construction Co., N. Tonawanda, New York.
 For page see List of Advertisers.
J. C. Moninger Co., 117 East Blackhawk St., Chicago, Ill.
 For page see List of Advertisers.
Foley Mfg. Co., between Western Ave. and 26th St., Chicago, Ill.
 For page see List of Advertisers.
I. Cassidy, Summer Ave. and Erie R. R., Newark, N. J.
 For page see List of Advertisers.
W. H. Lutton, Jersey City, N. J.
 For page see List of Advertisers.
Geo. B. Doane, 18 Midway St., Boston.
 Iron Pipe.
 For page see List of Advertisers.
S. Jacobs & Sons, 1365-79 Flushing Ave., Brooklyn, N. Y.
 For page see List of Advertisers.
Metropolitan Material Co., 1398-1408 Metropolitan Ave., Brooklyn, N. Y.

GREENHOUSE CONSTRUCTION

GREENHOUSE CONSTRUCTION, Semi-Iron Greenhouse, New Truss Houses and Iron Frame Houses, Lord & Burnham, 1133 Broadway, N. Y.
J. A. Payne, 260-274 Culver Ave., Jersey City, N. J.
 For page see List of Advertisers.
I. Cassidy, Summer Ave. and Erie R. R., Newark, N. J.
 For page see List of Advertisers.
Foley Mfg. Co., between Western Ave. and 26th St., Chicago, Ill.
W. H. Lutton, Jersey City, N. J.
 For page see List of Advertisers.

GREENHOUSE HOSE

Mineralized Rubber Co., 18 Cliff St., N. Y.
 For page see List of Advertisers.

GUTTERS

GUTTERS, Cast Iron Gutters, L. & B. Improved V Shaped Gutter with drip gutter attachment. Lord & Burnham, 1133 Broadway, N. Y.

HAIL INSURANCE

Florists' Hall Asso. of America, J. G. Esler, Saddle River, N. J.
 For page see List of Advertisers.

HARDY FERNS AND SUPPLIES

H. M. Robinson & Co., 15 Province St. and 9 Chapman Pl., Boston, Mass.
 For page see List of Advertisers.
The Kevan Co., 113 W. 28th St., N. Y.
 For page see List of Advertisers.
Michigan Cut Flower Exchange, 38 and 40 Broadway, Detroit, Mich.
 Fancy Ferns.
 For page see List of Advertisers.
 A full line of ferns, galax, and all wild greens. N. F. McCarthy & Co., 84 Hawley St., Boston.
 For page see List of Advertisers.

HEATING APPARATUS

Lord & Burnham Co., 1133 Broadway, New York.
 For page see List of Advertisers.
Pierson U-Bar Co., 1 Madison Sq., N. Y.
 For page see List of Advertisers.
Hitchings & Co., 1170 Broadway, N. Y.
 For page see List of Advertisers.
John A. Payne, 260-274 Culver Ave., Jersey City, N. J.
 For page see List of Advertisers.

In writing to Advertisers kindly mention Horticulture

HELP FURNISHED

Thos. H. Hambrick, 34 S. 7th St., Phila.
For page see List of Advertisers.

HOT-BED SASH

The A. T. Stearns Lumber Co., Neponset,
Mass.
For page see List of Advertisers.

Pierson U-Bar Co., 1 Madison Sq., N. Y.
For page see List of Advertisers.

Hitchings & Co., 1170 Broadway, N. Y.
For page see List of Advertisers.

Lord & Burnham Co., 1133 Broadway, N. Y.
For page see List of Advertisers.

Foley Mfg. Co., between Western Ave. and
26th St., Chicago, Ill.

INSECTICIDES.

Nicotifide kills all greenhouse pests.
P. R. Palethorpe Co.,
Eleventh St., Owensboro, Ky.
For page see List of Advertisers.

B. G. Pratt Co., 11 Broadway, New York.
For page see List of Advertisers.

JAPANA CUT FLOWER HOLDER

M. Y. Garmsay, 130 Waiola Ave.,
La Grange, Ill., Dept. F.
For page see List of Advertisers.

KENTIAS

A. Leuthy & Co., Roslindale, Mass.
For page see List of Advertisers.

Godfrey Aschmann, 1012 W. Ontario St.,
Philadelphia.
For page see List of Advertisers.

LEADING RETAIL FLORISTS

Park Floral Co., Denver, Colo.
For page see List of Advertisers.

George H. Cooke, Washington, D. C.
For page see List of Advertisers.

Gude Bros. Co., 1214 F St.,
Washington, D. C.
For page see List of Advertisers.

Atlanta Floral Co., Atlanta, Ga.
For page see List of Advertisers.

P. J. & J. E. Hauswirth, 232 Michigan Ave.,
Chicago.
For page see List of Advertisers.

William J. Smyth, Michigan Ave. and 31st
St., Chicago.
For page see List of Advertisers.

Jacob Schulz, 644 4th Ave., Louisville, Ky.
For page see List of Advertisers.

Thos. F. Galvin, 124 Tremont St., Boston.
For page see List of Advertisers.

Julius A. Zinn, 2 Beacon St., Boston.
For page see List of Advertisers.

Houghton & Clark, 396 Boylston St.,
Boston.
For page see List of Advertisers.

Sidney Hoffmaa, 59-61 Massachusetts Ave.,
Boston.
For page see List of Advertisers.

J. Breitmeyer's Sons, Detroit, Mich.
For page see List of Advertisers.

Samuel Murray, 1017 Broadway,
Kansas City, Mo.
For page see List of Advertisers.

Wm. L. Rock Flower Co., 1116 Walnut
St., Kansas City, Mo.
For page see List of Advertisers.

Fred C. Weber, 4326 Olive St., St. Louis,
Mo.
For page see List of Advertisers.

J. N. Champion & Co., 1026 Chapel St.,
New Haven, Conn.
For page see List of Advertisers.

H. G. Eyres, 11 N. Pearl St., Albany, N. Y.
For page see List of Advertisers.

David Clarke's Sons, 2129-2141 Broadway,
New York.
For page see List of Advertisers.

W. H. Donohoe, 17 E. 28th St., New York.
For page see List of Advertisers.

Alex. McConnell, New York.
For page see List of Advertisers.

LEADING RETAIL FLORISTS -

Continued

Robert G. Wilson, Fulton St. and Greene
Ave., Brooklyn, N. Y.
For page see List of Advertisers.

Thomas Young, Jr., 500 Fifth Ave., N. Y.
For page see List of Advertisers.

Young & Nugent, 42 W. 28th St., N. Y.
For page see List of Advertisers.

LOBELIAS

Jos. Fuller, 31 Orchard St., Leominster,
Mass.
Carter's Double Blue Lobelia.
For page see List of Advertisers.

NEW AND RARE PLANTS

Rose Hill Nurseries, New Rochelle, N. Y.
For page see List of Advertisers.

NICO-FUME

Kentucky Tobacco Product Co.,
Louisville, Ky.

NURSERY STOCK

John Waterer & Sons, Ltd.,
American Nursery, Bagshot, England.
For page see List of Advertisers.

New England Nurseries, Bedford, Mass.
Shrubs, Roses and Herbaceous Perennials.
Specimen Pyramidal Box.
For page see List of Advertisers.

Bay State Nurseries, N. Abington, Mass.
Herbaceous Perennials, Hardy Ornamental
Trees.
For page see List of Advertisers.

Cleary's Horticultural Co., 62 Vesey St.,
New York.
For page see List of Advertisers.

P. Ouwerkerk, 216 Jane St., Weehawken
Heights, N. J.
Holland Nursery Stock for Forclog.
For page see List of Advertisers.

American Nursery Co., 150 Broadway, New
York, N. Y.
For page see List of Advertisers.

Nursery Stock, N. F. McCarthy & Co.,
84 Hawley St., Boston, Mass.

ORCHID PLANTS

Lager & Hurrell, Summit, N. J.
For page see List of Advertisers.

Sander, St. Albans, England.
Importers, Exporters, Growers, Hybridists
For page see List of Advertisers.

Julius Roehrs Co., Rutherford, N. J.
For page see List of Advertisers.

Carrillo & Baldwin, Secaucus, N. J.
For page see List of Advertisers.

Jos. A. Manda, 191 Valley Road, W.
Orange, N. J.
For page see List of Advertisers.

Ordonez Bros., Madison, N. J., Box 105.
For page see List of Advertisers.

PALMS

A. Leuthy & Co., Perkins St. Nurseries,
Roslindale, Mass.
For page see List of Advertisers.

Robert Craig Co., Market and 49th Sts.,
Philadelphia, Pa.
For page see List of Advertisers.

Kentia, Phoenix, etc., all sizes. Write
for new price list. Julius Roehrs Co.,
Rutherford, N. J.

PAINT AND PUTTY

PAINT AND PUTTY: Ideal Greenhouse
lead; Special Greenhouse Putty. Lord &
Burnham, 1133 Broadway, N. Y.

PANSY PLANTS.

Choice pansy plants, 50c. per 100; \$4.00
per 1000. Cash. Aug. Ziruglebel, Need-
ham, Mass.

PATENTS

Siggers & Siggers, Washington, D. C.
For page see List of Advertisers.

PEAT

Orchid peat, Rotted peat, Azalea peat,
Leaf-Mould, Live Sphagnum moss, Baled
Sphagnum moss, Green Clump moss, etc.
Jobbers' list on application. C. W. Brown-
ell & Co., Walden, N. Y.

PELARGONIUMS

R. Vincent, Jr. & Sons Co., White Marsh,
Maryland.
For page see List of Advertisers.

PEONIES

One of the finest collections in America.
Send 25 cts. in stamps for new edition of
Peony Manual. C. S. Harrison's Select
Nursery, York, Neb.

PETUNIAS

Henry A. Dreer, Philadelphia.
Superb Double Petunias.

1500 DOUBLE PETUNIAS from soil,
\$1.25 per 100; \$10.00 per 1000. 2000 Little
Gem Feverfew, \$1.25 per 100; \$10.00 per
1000. E. V. B. Felthousen, 184 Van
Franken Avenue, Schenectady, N. Y.

500 Petunias, 8 best market sorts,
named, including a fair proportion of our
new "Camelia-flora," the best white
grown, needs no staking; well rooted,
\$1.25 per 100 prepaid, \$10.00 per 1000;
2 in short, stocky, \$2.50 per 100. Hopkins
& Hopkins, Chepachet, R. I.

PHLOXES

Send 25 cts. in stamps for Phlox Manual.
Fine mixed phloxes \$1.50 per 100. C. S.
Harrison's Select Nursery, York, Neb.

PIPE AND FITTINGS

Foley Mfg. Co., between Western Ave. and
26th St., Chicago, Ill.

PIPE AND FITTINGS. Cast Iron and
Wrought Pipe, Valves, Elbows, Pipe Hooks,
Automatic Air Headers, etc. Lord &
Burnham, 1133 Broadway, N. Y.

PLANT BED CLOTH

Mineralized Rubber Co., 18 Cliff St., N. Y.
For page see List of Advertisers.

POT HANGERS

Pot hangers, Kramer's \$1 doz. by exp.,
\$1.25 by mail. I. N. Kramer & Son, Cedar
Rapids, Ia.

PRUNING SHEARS

Rhodes Mfg. Co., Grand Rapids, Mich.
Dept. R.

RAFFIA

Raffia (colored), 20 beautiful shades.
Samples free. R. M. Comey Co., Camdea,
N. J.; 810 Washburn Ave., Chicago, Ill.

RHODODENDRONS

John Waterer & Sons, Ltd.,
American Nursery, Bagshot, England.
For page see List of Advertisers.

ROSES

Julius Roehrs Co., Rutherford, N. J.
Rambler Rose, Newport Fairy.
For page see List of Advertisers.

New England Nurseries, Inc., Bedford,
Mass.
Roses for Forcing.
For page see List of Advertisers.

Bay State Nurseries, N. Abington, Mass.
Roses for Forcing.
For page see List of Advertisers.

Ellwanger & Barry, Rochester, N. Y.
Hardy Roses.
For page see List of Advertisers.

John Cook, 318 Charles St., N. Baltimore,
Maryland.
Rose My Maryland.
For page see List of Advertisers.

Robert Craig Co., Market and 49th Sts.,
Philadelphia, Pa.
For page see List of Advertisers.

Charles H. Totty, Madison, N. J.
Grafted Stock.

ROSES—Continued

A. N. Pierson, Cromwell, Conn.
Grafted and Own Root Roses.

400 varieties; own roots; summer grown.
Leedle Company, Springfield, Ohio.

Crimson Ramblers, 2 year, on own roots,
extra strong, at 7 cents. Gilbert Costich,
Rochester, N. Y.

Low-budded roses, No. 1, \$95.00; No.
11-2, \$65.00 1000. H. T. Jones, Elizabeth,
N. J.

SCALECID

B. G. Pratt Co., 11 Broadway, New York.
For page see List of Advertisers.

SEEDS

T. J. Grey Co., 32 So. Market St.,
Boston, Mass.
For page see List of Advertisers.

Joseph Breck & Sons,
51 and 52 N. Market St., Boston, Mass.
For page see List of Advertisers.

W. Atlee Burpee & Co., Philadelphia.
For page see List of Advertisers.

J. M. Thorburn & Co., 33 Barclay St., N. Y.
For page see List of Advertisers.

A. T. Boddington, 342 W. 14th St., N. Y.
For page see List of Advertisers.

H. F. Michell Co., 1017 Market St., Phila.
For page see List of Advertisers.

James Vlek's Sons, Rochester, N. Y.
Vlek's Superb Pansy Seed.
For page see List of Advertisers.

Hjalmar Hartmann & Co.,
12 Stormgade, Copenhagen, Denmark.
Cauliflower and Cabbage Seed.
For page see List of Advertisers.

Rickards Bros., 37 E. 19th St., New York.
For page see List of Advertisers.

R. & J. Farquhar & Co., 6-7 So. Market
St., Boston.
Glant Cyklenen Seed.
For page see List of Advertisers.

C. C. Morse & Co., 48-56 Jackson St.,
San Francisco, Cal.
For page see List of Advertisers.

H. E. Fiske Seed Co., Faneuil Hall Sq.,
Boston.
For page see List of Advertisers.

Braslan Seed Growers Co., San Jose, Cal.
For page see List of Advertisers.

O. V. Zangen, Hoboken, N. J.
For page see List of Advertisers.

R. Wiboltt, Nakskov, Denmark.
Snowball Cauliflower Seed.
For page see List of Advertisers.

Wm. Elliott & Sons, 201 Fulton St.,
New York.
Lincoln Pansy Seed.
For page see List of Advertisers.

Sander & Son, Bruges, Belgium.
Cocos Weddelliana Seed.

Stampp & Walter Co., 50 Barclay St.,
New York.
Flower Seeds New Crop.
For page see List of Advertisers.

Crego aster seed. Ask for circular. G.
S. Crego, Maywood, Ill.

SMILAX

E. A. Beaven, Evergreen, Ala.
Southern Wild Smilax; Log Mosses.
For page see List of Advertisers.

SPHAGNUM MOSS

Live Sphagnum moss, orchid peat and
orchid baskets always on hand. Lager &
Hurrell, Summit, N. I.

STEAM TRAP

E. Hippard, Youngstown, O.

VEGETABLE PLANTS

A few millions Frost Proof Cabbage
Plants of all the best varieties at \$1.25
per 1,000; \$1 per 1,000 above 5,000. Ex-
press at Charleston, S. C. Special price
for large lots. Rates on plants very low.
Alfred Jouannet, Mt. Pleasant, S. C.

VENTILATING APPARATUS

Pierson U-Bar Co., 1 Madison Sq., N. Y.
For page see List of Advertisers.

Hiltbings & Co., 1170 Broadway, N. Y.
For page see List of Advertisers.

Foley Mfg. Co., between Western Ave. and
26th St., Chicago, Ill.
For page see List of Advertisers.

John A. Payne, 260-274 Culver Ave., Jersey
City, N. J.
For page see List of Advertisers.

VENTILATING MACHINERY, New
Model encased, self-oiling gear; Standard
Model Open Gear. Lord & Burnham, 1133
Broadway, N. Y.

VIOLETS

William Sim, Chittendale, Mass.
Violet Boston.
For page see List of Advertisers.

Violet cuttings, "Maria Louisa" Rhine
beck stock, rooted runners, May delivery
\$20.00 M. Immediate delivery, between
now and March 15th, \$10.00 M. Wm. F.
Kasting Co., 383 Elliott St., Buffalo, N. Y.

WIREWORK

Reed & Keller, 122 W. 25th St., N. Y.
For page see List of Advertisers.

Wirework. Write for our catalogue.
Holton & Hunkel Co., Milwaukee, Wis.

William E. Hellscher's Wire Works, 38-40
Broadway, Detroit, Mich.

The "Just Right" kind. Send for price
list. Frank W. Ball, 31 East Third Street,
Cincinnati, O.

WHOLESALE FLORISTS

Boston

N. F. McCarthy & Co., 84 Hawley St.,
Boston.
For page see List of Advertisers.

H. M. Robinson & Co., 15 Province St.
and 9 Chapman Pl., Boston.
For page see List of Advertisers.

Welch Bros., 226 Devonshire St., Boston.
For page see List of Advertisers.

Buffalo

Wm. F. Kasting Co., 383-87 Elliott St.,
Buffalo, N. Y.
For page see List of Advertisers.

Chicago

Chas. W. McKellar, 51 Wabash Ave.,
Chicago.
For page see List of Advertisers.

Peter Reinberg, 51 Wabash Ave., Chicago.
For page see List of Advertisers.

E. F. Winterson Co., 45-49 Wabash Ave.,
Chicago.
For page see List of Advertisers.

Detroit

Michigan Cut Flower Exchange, 38 and 40
Broadway, Detroit, Mich.
For page see List of Advertisers.

New York

J. K. Allen, 106 W. 28th St., New York
For page see List of Advertisers

J. S. Fenrich, 110 W. 28th St., New York.
For page see List of Advertisers.

Ford Bros., 48 W. 28th St., New York
For page see List of Advertisers

H. E. Froment, 57 W. 28th St., New York.
For page see List of Advertisers.

Alex. J. Guttman, 43 W. 28th St., New
York.
For page see List of Advertisers.

E. C. Horan, 55 W. 28th St., New York
For page see List of Advertisers

WHOLESALE FLORISTS—

New York—Continued

A. H. Langjahr, 55 W. 28th St., New York.
For page see List of Advertisers.

James McMannus, 42 W. 28th St., New York.
For page see List of Advertisers.

John I. Raynor, 49 W. 28th St., New York.
For page see List of Advertisers.

W. F. Sheridan, 39 W. 28th St., New York.
For page see List of Advertisers.

Traendly & Schenck, 44 W. 28th St., New
York.
For page see List of Advertisers

John Young, 51 W. 28th St., New York.
For page see List of Advertisers.

Moore, Hentz & Nash, 55 and 57 W. 26th
St., New York.
For page see List of Advertisers.

Frank S. Hicks & Co., 52 W. 28th St.,
New York.
For page see List of Advertisers.

Frank Millang, 57 W. 26th St., New York.
For page see List of Advertisers.

Wm. H. Kuebler, 28 Willoughby St.,
Brooklyn, N. Y.
For page see List of Advertisers.

Phillip E. Kessler, 55 and 57 W. 26th St.,
New York.
For page see List of Advertisers.

A. Moltz, 55-57 W. 26th St., New York.
For page see List of Advertisers.

B. S. Silnan, Jr., 55 W. 26th St., New York.
For page see List of Advertisers.

A. L. Young & Co., 54 W. 28th St., New
York.

Philadelphia

W. E. McKissick, 1619-1621 Ranstead St.,
Philadelphia, Pa.
For page see List of Advertisers.

Leo Nlessen Co., 1209 Arch St., Philadel-
phia, Pa.
For page see List of Advertisers.

The S. S. Pennock-Meehan Co., 1608-18
Ludlow St., Philadelphia, Pa.
For page see List of Advertisers.

Edward Reid, 1526 Ranstead St., Phila-
delphia, Pa.
For page see List of Advertisers.

Pittsburg

J. B. Murdoch & Co., 714 Penn Ave., Pitts-
burgh, Pa.
For page see List of Advertisers.

Providence, R. I.

J. Kopelman & Co., 21 Washington St.,
Providence, R. I.
For page see List of Advertisers.

San Francisco

Alex. Mann, Jr., Co., 1125 Polk St., San
Francisco, Cal.
For page see List of Advertisers.

St. Louis

H. G. Berning, 1402 Plue St., St. Louis, Mo.
For page see List of Advertisers

Washington, D. C.

J. J. Harty & Co., 1312 G. St. N. W.,
Washington, D. C.
For page see List of Advertisers.

WHOLESALE PLANT MARKETS

Philadelphia Plant Exchange, 839 Market
St., Philadelphia.
For page see List of Advertisers.

WHOLESALE PLANTSMAN

Samuel A. Woodrow, 53 W. 30th St.,
New York.
For page see List of Advertisers.

In writing to Advertisers kindly mention Horticulture

List of Advertisers

	Page		Page
Allen J. K.	246	Leuthy A. & Co.	226
American Nursery	237	Lord & Brittain Co.	257
American Nursery Co.	237	Lutton W. H.	253
Aschmann Godfrey	270	Manda Jos. A.	241
Atlanta Floral Co.	243	Maup, Alex. Jr. Co.	247
		MacMullen L. A.	243
		McCarthy N. F. & Co.	247
Bambrick Thos. H.	252	McConnell Alex.	243
Barrows H. H. & Son	227	McKellar Charles W.	244
Baur Floral Co.	227	McKissick, W. E.	244
Bayersdorfer H. & Co.	244	McManus Jas.	240
Bay State Nurseries	237	Michell H. F. Co.	238
Beaven E. A.	247	Michigan Cut Flower Exchange	247
Bernine H. G.	247	Milang Frank	247
Boddington A. T.	239	Mineralized Rubber Co.	255
Boston Florist Letter Co.	24	Moltz, A.	247
Boston Plate and Window Glass Co.	254	Moninger J. C.	255
Bosch, Felix	238	Moore, Hentz & Nash	247
Braslan Seed Growers Co.	239	Moore, J. L.	240
Breck Joseph & Sons	230	Morse C. C. & Co.	230
Breitmeyer's J. Sons	243	Murdoch J. B. & Co.	245
Bridgeman's Seed Warehouse	230	Murray Samuel	243
Burpee W. A. & Co.	239		
		New England Nurseries	237
Carrillo & Baldwin	241	Niessen Leo. Co.	220
Cassidy I.	255	Ordonez Bros.	241
Champion J. N. & Co.	243	Ouwertkerk P.	237
Chicago Carnation Co.	247		
Childs John Lewis	240	Palethorpe P. R. Co.	251
Clarke's David, Sons	243	Park Floral Co.	243
Cleary's Horticultural Co.	247	Park Street Flower Market	228
Conard & Jones Co.	246	Payne John A.	254
Cook John	227	Pennock-Meehan Co.	244
Cooke G. H.	243	Perkins St. Nurseries	220
Covee A.	238	Peterson J. A.	241
Craig, Robt. Co.	246	Pierce Nursery	240
		Pierson, A. N.	227
Doane Geo. B. & Son	254	Pierson F. R. Co.	227
Donohoe W. H.	243	Pierson U Bar Co.	250
Dorner F. Sons & Co.	227	Pratt B. G. Co.	254
Dreer H. A.	241	Pulverized Manure Co.	254
Dysart R. J.	245		
		Raynor John L.	240
Edgar, W. W. Co.	244	Red Oak Nurseries	226
Edwards Folding Box Co.	244	Reed & Keller	247
Elliott Wm. & Sons	239	Reid Edw.	244
Ellwanger & Barry	237	Reinberg Peter	244
Esler J. G.	254	Rickards Bros.	239
Ernest W. H.	254	Robinson H. M. & Co.	247
Eyres	243	Rock Wm. L. Flo. Co.	243
		Roehrs Julius Co.	237
Farquhar R. & J. Co.	239	Rolker August & Sons	226
Fenrich J. S.	246	Rose Hill Nurseries	237
Fiske, H. E. Seed Co.	239	Rusconi D.	239
Foley Mfg. Co.	255		
Ford Bros.	245	Sander & Son	241
Froment H. E.	246	Schlegel & Fottler Co.	238
Fuller J.	226	Schulz Jacob	243
		Scott, John	226
Galvin Thos. F.	243	Sheridan W. F.	246
Garnsey M. V.	242	Siggers & Siggers	255
Grey T. J. Co.	239	Sim, Wm.	237
Gude Bros. Co.	243	Situations & Wants	254
Guttman Alex. J.	240	Skidelsky S. S.	227
		Slinn B. S. Jr.	246
Haerens A.	226	Smyth Wm. J.	243
Hall Asso.	254	Standard Plate Glass Co.	255
Haines, J. E.	227	Stearns A. T. Lumber Co.	255
Hartmano Hjalmar & Co.	239	Stump & Walter Co.	226
Harty, Jas. J. & Co.	244		
Hauswirth P. J. & J. E.	243	Thorburn J. M. & Co.	239
Herbert David & Son	226	Totty Chas. H.	227
Hews A. H. & Co.	254	Traendly & Schenck	246
Hicks Frank S. & Co.	217		
Hilfinger Bros.	254	Valentine, J. A.	243
Hitchings & Co.	256	Velthuys K.	238
Hoffman	243	Vick's Jas. Sons	239
Horan E. C.	246	Vincent R. Jr. & Sons	226
Houghton & Clark	243		
		Waterer John & Sons	237
Jahn, H. A.	227	Weber F. C.	243
Jacobs S. & Sons	155	Welch Bros.	244
		Wiboltt, R.	240
Kasting W. F.	247	Wilson	243
Kervan Co., The	245	Winterson, E. F. Co.	244
Kessler, P. F.	246	Woodrow, Sam'l A.	247
Kimberly Frank H.	227		
King Cons. Co.	255	Vokohama Nursery Co.	230
Kouelman J. & Co.	245	Young John	246
Koral Mfg. Co.	242	Young, Thos. Jr.	243
Kramer Prop. Fdy. Co.	252	Young & Nugent	243
Kuebler Wm. H.	247		
		Zangen O.V.	230
Lager & Hurrell	241	Zinn, J. A.	243
Langjahr Alfred H.	240		
Leonard I. & J.	241		

Is Your Name In The Above List? If Not, Why Not?

New Offers in This Issue.

ADIANTUM FARLEYENSE; BEGONIA GLOIRE DE LORRAINE.
J. A. Peterson, McHenry Ave., Westwood, Cincinnati, Ohio.
For page see List of Advertisers.

ASPARAGUS PLUMOSUS NANUS
A. N. Pierson, Cromwell, Conn.
For page see List of Advertisers.

CALLA ELLIOTTIANA, CALADIUMS, CANNAS, DAHLIA SOUVENIR DE GUSTAVE DOAZON.
Henry A. Droer, 711 Chestnut St., Philadelphia.
For page see List of Advertisers.

CARNATIONS WINSOR, WHITE ENCHANTRESS.
White Bros., Gasport, N. Y.
For page see List of Advertisers.

CYCLAMENS, ASPARAGUS AND SUMMER FLOWERING BULBS AND ROOTS.
Schlegel & Fottler Co., 26 & 28 So. Market St., Boston.
For page see List of Advertisers.

EASTER PLANTS.
Win. W. Edgar Co., Waverly, Mass.
For page see List of Advertisers.

FORMOSA LILIUM LONGIFLORUM.
Yokohama Nursery Co., 31 Barclay St., New York.
For page see List of Advertisers.

GLADIOLUS AMERICA, PHOENIX ROEBELINI, LILIES.
John Lewis Childs, Floral Park, N. Y.
For page see List of Advertisers.

GLADIOLUS BULBS, CALIFORNIA PRIVET, AMERICAN CHESTNUTS.
I. & J. L. Leonard, Iona, N. J.
For page see List of Advertisers.

HERBACEOUS PERENNIALS.
Red Oak Nurseries, Fiskeville, R. I.
For page see List of Advertisers.

RETAIL FLORIST.
Edward MacMullen, 194 Boylston St., Boston.
For page see List of Advertisers.

SINGLE CHRYSANTHEMUMS.
Chas. H. Totty, Madison, N. J.
For page see List of Advertisers.

SPRING DECORATIVE AND BEDDING PLANTS.
R. Vincent, Jr., & Sons Co., White Marsh, Maryland.
For page see List of Advertisers.

TREE SEEDLINGS AND ROOTED CUTTINGS.
Pierce Nurseries, Beverly Farms, Mass.
For page see List of Advertisers.

FOR SALE

Greenhouse property consisting of five houses, two each 300 x 16, one 150 x 11, one 200 x 10, one 20 x 12, 1.5 feet connecting sheds. Heated by two 40 horse power, high pressure boilers. Small engine for operating blower. City water. Dwelling-house five rooms and barn. Eight acres of land. Place has been built five or six years. Located five minutes from electric cars, twenty minutes' ride to a city of 50,000 population and about twenty miles from Boston. This affords an exceptionally good chance for anyone desiring to go into the growing of flowers for wholesale, also for a very extensive retail business later on. Possession given any time after July 1st. Place can be bought very reasonable, one half payment cash, balance on mortgage.
For further particulars apply to

P. WELCH

Care of WFLGH BROS., 226 Devonshire St., Boston

WANTS, FOR SALE, ETC.

Advertisements in this column one cent a word. Initials count as words. Cash with order. All correspondence addressed "care HORTICULTURE" should be sent to 11 Ham-filton Place, Boston.

HELP WANTED

WANTED—SALESMAN

To Handle Good Side Line
On Commission

One who calls on Florists, Seed Houses, Nurseries, Cemetery Superintendents, Monument Dealers, etc.

The Kramer Bros. Foundry Co.
DAYTON, OHIO

SITUATIONS WANTED

GOOD MEN

When you need good men,
skilled or unskilled, Write:

THOS. H. BAMBRICK

34 South 7th Street Philadelphia

Help of all kinds, including that for Florists, Nurserymen, Seedsmen and the Horticultural trade generally.

SITUATION WANTED—As foreman or manager, by sober, industrious, ambitious young man with long experience on some of the best wholesale and retail places in America; good grower of carnations, roses, and general all-round stock; familiar with steam and hot water, pipe fitting, greenhouse building, etc.; only those having a first-class place, wanting No. 1 stock grown, and who are willing to give a competent man a chance to have success, need answer; good salary expected; references; state full particulars. Address X. Y. Z., Bridgeport, Conn.

SITUATION WANTED in general greenhouse work; single, age 35, five years' experience, commercial. Address W. W., care HORTICULTURE.

FOR SALE

FOR SALE OR TO LET—15 acres of land, nearly all under cultivation; 20,000 sq. ft. glass, house well stocked with carnations, chrysanthemums, etc.; 8-room dwelling house, steam heated; large barn; in a city of 14,000 population, 10 miles from Boston; excellent transportation facilities. Good retail trade now established. Terms will be made satisfactory. Possession given April 1 or sooner if desired. Address A. G., care HORTICULTURE.

FOR SALE—A large consignment of 16x24 double thick American glass, A and B quality. For further information write Parshelsky Brothers, 59 Montrose Avenue, Brooklyn, N. Y.

MISCELLANEOUS WANTS

WANTED,

To buy, to lease with the right to buy, or to lease, several Greenhouses with ground where retailing and landscaping is possible.
Address L. L., care of HORTICULTURE.

VEGETABLES UNDER GLASS.

Read before the Massachusetts Horticultural Society by William Turner.

William Turner of Oceanic, N. J., addressed the Horticultural Society on February 8, on "Forcing of Vegetables Under Glass." Whoever, he said in beginning, wishes to have success in this line, must have a love for the work and watch the developments so as to know when and how to feed them. As a private gardener, he confined his remarks to private establishments in general, and the house he recommended was from 20 to 28 feet wide, with a preference toward east and west, and hot water heat.

"Experience has taught me," said Mr. Turner, "that some soils will take much more food than others. I claim there can be no hard and fast lines laid down in regard to how much fertilizer a certain crop shall receive for best results. My theory has always been that each grower in different localities, and different soils, by studying the condition of his growing crops is the best judge as to how much food will be of benefit. I have no doubt there are various opinions on this one important subject—feeding—but the grower, who carves his own road, using his own good judgment, will usually come out the most successful. We know that to produce good crops, potash, phosphoric acid and nitrogen is a necessity. This should be applied to the soil in some shape or form. I am confident whoever has given this question study and deep thought will stand by his own good judgment; self-taught experience one never forgets. Pages could be written on this one subject alone—feeding.

Lettuce.

"The demand for lettuce is ever increasing, and without doubt this is one of the main winter crops. Whether for private or for commercial purposes, monstrous houses have been built for the lettuce industry within the past few years, which probably twenty-five years ago would have been thought madness. Years ago lettuce was grown on raised benches. It was thought of much benefit having the plants near the glass, but certainly a mistaken idea, for those cool-blooded vegetables. In the first place, it is too hot for the roots; and, second, the plants require too much water on the benches. One great advantage in solid beds is, the crops don't require water very often. In fact, if the surface soil can be kept on the dry side, providing there is plenty of moisture below, the roots then will have a tendency to work down, giving the plants health and vigor, which is all important for best results, but a thorough good watering just as they begin to head will help to increase the size and quicken maturity. Airing plays an important part as regards success or failure with this ever-popular vegetable. The most dreaded fungus or disease is commonly called sunburn, although this is an erroneous idea, as the disease spreads more readily in a spell of dull weather than when it is bright. One thing is certain, when a crop is badly infested it is useless; better throw it out, take the top soil out and replace with fresh

or sterilize the soil, as the only safeguard to eradicate the evil.

Cauliflower.

"Probably there is no vegetable more improved by growing under glass than cauliflower, requiring the same treatment in every respect as lettuce, as regards temperature, solid beds, etc., but the soil used may be of a trifle heavier nature and it is perfectly safe to feed them considerably more than lettuce as they are strong rooting vegetables. Yes, even during the short day this vegetable will respond readily to liberal treatment. I would not advocate starting your plants before say the first week in September. Sow seed according to the number of plants required. Transplant once about four inches apart, than in about three weeks transplant again where they are to mature, in rows eighteen inches apart and fifteen inches in the rows. The first crop should be ready to cut from the first of December on. For a succession sow seed two weeks apart. Cauliflower delights in rich compost, and without doubt a liberal supply of hardwood ashes is a capital fertilizer for this crop. I question if there is another vegetable forced that will take as much nitrate of soda to good advantage as the cauliflower.

Radishes.

"Radishes are easily produced under glass. I have seen it recommended taking a crop of radishes from among lettuce or any other growing crop, the idea being that the radish crop under favorable conditions will mature in about a month from the time of sowing the seed. However, this method I am not in favor of, claiming that one crop at a time is sufficient even if grown under glass. While radishes are of easy culture, it is true, I think that I am safe in stating that many a batch of radishes have been destroyed by the erroneous impression that this crop needs little or no attention. If left in the bed too long they get soft and pithy, comparative useless at that stage. The very best seed obtainable should be used for this purpose. Radishes can be grown successfully with the lettuce house temperature.

Tomatoes.

"Good tomatoes can be had either in solid beds or raised benches. But for the winter months raised benches are decidedly to be preferred. Wonderful progress has been made in recent years. In the quantity of tomatoes consumed compared to years ago, and particularly so with the forced products, not only in the private establishments, but it is also quite a commercial enterprise. In the first place we should aim to start plants so that there will be a good set of fruit before the shortest days set in; this will give a heavy picking through the shortest days. To get this seed should be sown not later than the first of August. Those plants for winter forcing I prefer growing in pots up to five-inch, potting firm; nothing like having stocky, short-jointed, thrifty plants to set in the bench. Tomatoes are not particular as to soil. However, the best is none too good for the work. What I would term a good rose soil would be ideal for tomatoes, with about half the quantity of manure.

Four or five inches of soil is sufficient to mature a heavy crop of fruit. One of the main features in keeping a healthy, vigorous growth is the temperature. I am not an advocate of high temperatures (say 60 at night, 70 to 75 degrees in the day, according to conditions of weather, and give air every available chance, never allowing the foliage to get soft and flabby), then there will not be much trouble with mildew and kindred diseases.

Cucumbers.

"Years ago if we produced a crop of cucumbers in the fall and another in the spring it was not altogether necessary through the shortest days. Now there is a call for them at all seasons. Probably the commercial grower has been responsible for popularizing this vegetable in a general way more than the private gardener, as their produce goes on the market where it is sold broadcast to the public, which naturally causes a brisk demand. I believe I am correct in stating that Arlington growers were the first to see into the possibilities of raising cucumbers on a large scale for market as a financial success, and today I believe Arlington is the largest centre for this ever-growing enterprise. Heat, moisture and careful airing are the important items to contend with. While cucumbers are rapid, vigorous growers, with good treatment, on the other hand any neglect is easily detected by the stunted appearance of their growth. In fact, a severe check is disastrous. There is an advantage in one way with growing the English cucumbers in winter. They need no fertilizing, not unless it is necessary to procure some seed.

Beans.

"While beans are not grown commercially, under glass, they are very acceptable for the private table, and far superior to any that can be procured in the open market during the winter months; therefore, for private green-houses beans are to be highly recommended as a forced vegetable. When grown successfully it is surprising the amount that can be gathered from them. There are two methods of growing this crop—in pots or on raised benches. If grown in pots, half fill six or seven-inch pots with fairly rich, porous soil, then plant about six beans in a pot. As the beans grow keep adding soil by degrees, until filled. It takes about seven weeks to mature a crop grown in a temperature of 60 to 65 degrees at night, with 70 to 75 day temperature. The bench system is my preference, as there is not so much labor and attention required, and results are equal, if not better.

Rhubarb.

"I do not consider the forcing list complete minus rhubarb. There is considerable demand for this wholesome vegetable, both private and commercially. It requires very little attention; the main secret is if the roots are dug for forcing they should get a thorough freezing before they are taken into the forcing house. Also leave as much of the soil adhering to the roots as possible. These roots may be forced successfully in the mushroom house or under the tomato house bench, setting the roots close together, filling in the hollow spaces

between the roots with soil or leaf mould—anything to hold moisture. Every two weeks a fresh supply of crowns may be brought in according to demands. Greenhouse vegetable forcing has come to be one of the important branches of our profession, and appeals readily to the consumer, as they are not subjected to extreme temperatures such as our early garden vegetables are at times. The results are they are tender and can be appreciated by all."

GREENHOUSES BUILDING OR CONTEMPLATED.

- Auburn, Neb.—E. W. Sulzbaugh, two houses.
- Wyomissing, Pa.—Frank Shearer, one house.
- Minaville, N. Y.—R. S. Ernest, lettuce house.
- Eldorado, Kan.—W. H. Noble, improvements.
- Fostoria, O.—Fostoria Floral Co., four houses.
- Beatrice, Neb.—Dole Floral Co., palm house, 35x100.
- Milwaukee, Wis.—M. P. Vallier, two carnation houses.
- Lincoln, Neb.—C. H. Frey, four houses, each 28x200.
- Clayton, Mo.—George Hecht, two houses, each 25x100.
- Pittsburg, Pa.—H. L. Blind & Bros., greenhouse and store.
- Fargo, N. D.—Agricultural college, three houses, each 29x60.
- Tacoma, Wash.—Northwestern Floral Co., two houses, each 29x100.
- Natick, Mass.—Waban Rose Conservatories, 300 feet addition to rose house.
- Hoopeston, Ill.—Peterson & Lawrence, three carnation houses, each 27x250; two rose houses.

LIST OF PATENTS.
Issued February 4, 1908.

- 877,913. Surface Hoe. John A. Crummer, Grant township, Pocahontas county, Iowa.
- 877,955. Motor Plow. George M. Shimp, Celina, Ohio.
- 877,988. Power Cultivator. Edson E. Deschane and Joseph C. Littlewood, Minneapolis, Minn.
- 878,026. Plow Point. Watson Titus, South Haven, Kans., assignor of one-sixth to Chas. P. Hagen, Wellington, Kans., and one-third to Chas. H. Davis, South Haven, Kans.
- 878,033. Breaking Plow. John D. Arras, Rawson, Ohio.
- 878,116. Method of separating Buckhorn and Plantain Seeds from Clover Seeds. Joseph P. Burgess, Depauw, Ind.
- 878,285. Potato Harvester. Frederick W. Helmburger, Huron, Ohio.

HORTICULTURE'S REPRESENTATIVES.

The following named gentlemen represent this paper in their various local districts, and are authorized to accept subscriptions, advertisements and news items:

- BUFFALO, N. Y.—E. C. Brucker, 385-87 Elliott St.

"SCALECIDE"

HAS MADE SPRAYING EASY THEN WHY NEGLECT YOUR TREES?

The N. Y. Herald, November 17, '07, says: "The chances are about a hundred to one that you have the San Jose Scale on your place and do not know it," and advises the use of "SCALECIDE." This is good advice. "SCALECIDE" has been tested and tried, and found thoroughly effective. The same yesterday, to-day, and all the time. One gallon makes 15 to 20, ready to use, by simply adding water.

Prices: 1 gal., \$1.00; 5 gal., \$3.25; 10 gal., 6.00; 50 gal. bbl., \$25.00. F. O. B. our factory. Order to-day. Write for booklet W and free sample.

B. G. PRATT CO., Mfg. Chemists,
11 Broadway, New York City.

- CINCINNATI, OHIO—Frank W. Ball, 31 East 3rd St.
- DETROIT, MICH.—Frank Danzer, 1487 15th St.
- INDIANAPOLIS, IND.—George B. Wiegand 1610 N. Illinois St.
- MONTREAL, P. Q.—Gabriel Vreugde, 27 Ontario Ave.
- NEWPORT, R. I.—David McIntosh, Ledge Road.
- MINNEAPOLIS, MINN.—C. N. Ruedlinger, 2924 So. Aldrich Ave.
- PHILADELPHIA, PA.—George C. Watson, Dobson bldg., 9th and Market Sts.
- PITTSBURG, PA.—James Hutcheson, corner Dunmoyle and S. Negley Aves.
- TOLEDO, OHIO—J. L. Schiller, 929 Prouty Ave.

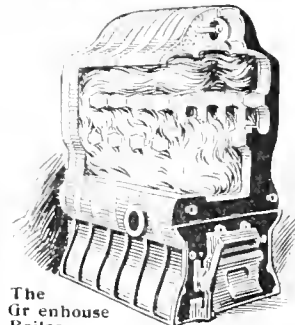

The Greenhouse Boiler

and we had no difficulty in maintaining a temperature of 60°" is the testimony of a well known Pennsylvania florist who is using my GREENHOUSE BOILER.

Let me quote you prices.

JOHN A. PAYNE,
Horticultural Architect and Builder.

Main Office and Factory:
260-274 Culver Ave., Jersey City, N. J.
Sash opening apparatus and all kinds of greenhouse structural material.

IRON PIPE

SECOND HAND

WROUGHT IRON PIPE, for Steam, Water, Gas or Oil, Fences or Posts.
All Sizes. Price Low.

GEO. B. DOANE & SON

18 Midway Street, BOSTON
Telephone, Main 4419

BOSTON PLATE & WINDOW GLASS CO.
GREENHOUSE GLASS
German and American

261 to 287 A St., BOSTON 20-22 Canal St.
The FLORISTS' HALL ASSOCIATION OF AMERICA, insurer of 28,000,000 sq. ft. of glass. For particulars address John C. Esler, Sec'y, Saddle River, N. J.



The Best
Bug Killer and
Bloom Saver

For PROOF
Write to

P. R. Palethorpe Co.
OWENSBORO, KY.



STANDARD FLOWER POTS

Packed in small crates, easy to handle.

Price per crate	Price per crate	
1500 2 in. pots in crate \$4.88	120 7 in. pots in crate \$4.20	
1500 2 1/4 " " " 5.25	60 8 " " " 3.00	
1500 2 1/2 " " " 6.00	HAND MADE	
1000 3 " " " 5.00	48 9 in. pots in crate \$3.60	
800 3 1/2 " " " 5.80	48 10 " " " 4.80	
500 4 " " " 4.50	24 11 " " " 3.60	
320 5 " " " 4.51	24 12 " " " 4.80	
144 6 " " " 3.16	6 16 " " " 4.50	

Send pans, same price as pots. Send for price list of Cylinders for Cut flowers, Hanging Baskets, Lawn Vases, etc. Ten per cent. off for cash with order. Address **Hilfinger Bros., Pottery, Fort Edward, N. Y.** August Holker & Sons, Agts., 31 Barclay St., N. Y. City.

Standard Flower POTS

If your greenhouses are within 500 miles of the Capitol, write us, we can save you money

W. H. ERNEST,
28th and M Street WASHINGTON D. C.



Cattle Manure
In Bags

Shredded or Pulverized

Best and safest manure for florists and greenhouse use, absolutely pure, no waste, no danger. Write for circulars and prices.

The Pulverized Manure Co.,
31 Union Stock Yards, Chicago

WILLIAM H. LUTTON

HORTICULTURAL ARCHITECT AND BUILDER

WEST SIDE AVENUE STATION (C. R. R. OF N. J.)
JERSEY CITY, N. J.

Have not been established 50 years, but long enough to convince the wide-awake Florist and Gardener that it is to his interest to place his work in thoroughly practical hands.

(150,000 sq. ft. glass erected in 1907 will substantiate this claim)

And why not? My material is the best that can be secured. My iron frame construction has every modern feature that years of practical experience can embody.

AND THEN THERE IS THE COST TO BE CONSIDERED.

Why not let us take up this important question now?

GREENHOUSE GLASS

Cheaper Now Than For Years

We are taking contracts for next Spring delivery.

WRITE FOR OUR PRICES

STANDARD PLATE GLASS COMPANY

26-30 Sudbury St. 61-63 Portland St.
 BOSTON, MASS.

CYPRESS SASH BARS
 82 feet or longer
HOT BED SASH
PECKY CYPRESS BENCH LUMBER

GREENHOUSES
 ERECTED AND EQUIPPED COMPLETE IF DESIRED

Write for Circular "D" and Prices

The A. T. STEARNS LUMBER CO.
 NEPONSET, BOSTON, MASS.

S. JACOBS & SONS
 Manufacturers of GULF CYPRESS

GREENHOUSE MATERIAL
 HOT-BED-SASH & FRAMES
 Jobbers in **Boilers-Pipe-Fittings** and
GLASS on which we can quote attractive prices
 We furnish everything for Greenhouse Building
1365-1379 Flushing Avenue
BROOKLYN, - NEW YORK

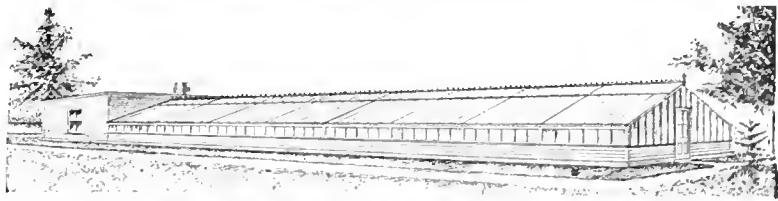

GREENHOUSE MATERIAL

Furnished and Erected. Write for Prices

I. CASSIDY, SUMMER AVENUE AND ERIE R. R. Newark, N. J.

NOW IS THE
 RIGHT TIME
 TO FIGURE

MATERIAL

AND PLAN FOR
 THE BUILDINGS
 OF THIS YEAR

FOLEY'S } QUALITY AND WORK THE BEST
 PRICES RIGHT AND LOWEST.
 ESTIMATES WILL PROVE. TRY US.

Foley Ventilating Apparatus Unequaled

Will Ventilate any Size of House Easily. Send for Circular.

THE FOLEY MFG. CO. Western Ave. 25th & 26th Sts. CHICAGO

ANCHOR GREENHOUSE HOSE

WEARS WELL.
 PLANT BED CLOTH
 Protects from Cold and Dampness.

MINERALIZED RUBBER CO.
 18 Cliff Street New York

GREENHOUSE CONSTRUCTION LUMBER

John C. Moninger Co.
 117 E. Blackhawk St., CHICAGO



PATENTS

Trademarks and Copyrights

Send your business direct to Washington. Saves time and insures better service. Personal attention guaranteed. Twenty-five years' active service. SPECIALTY: "Working on the Failures of Others."

SIGGERS & SIGGERS

PATENT LAWYERS
 Box 9, National Union Building
 Washington, D. C.

Holds Glass Firmly FULL SIZE N. 2

See the Point of PEERLESS

Finishing Points are the best no rights or 10c. Box of 100 points 75 cts. postpaid.

HENRY A. DEEER,
 714 Chestnut St. Phila. Pa.

In ordering goods please add, "I saw it in HORTICULTURE"

H AND C



Nobody Wants an Eave Plate Like This in His **Greenhouse**

BUY OUR HOUSE WITH **Steel Angle Eave Plates and Roof Cast Iron Bar Brackets, both galvanized**

See Illustration in Our Next Week's Ad.

HITCHINGS & CO.

1170 Broadway
NEW YORK

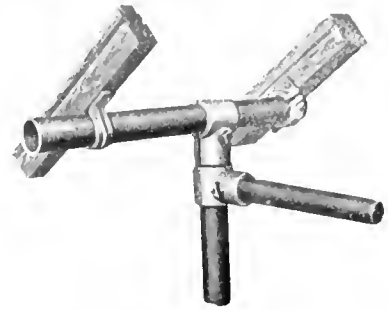

This cut shows the various fittings in their relative positions when used in the Giant Arch.

GIANT CLAMP INFORMATION

Is thoroughly set forth in that Clamp Column circular which we want you to send for.

WE MAKE EVERY PART OF A GREENHOUSE BUT THE GLASS. WE SELL ANY PART.

LORD & BURNHAM CO.

1133 BROADWAY, cor. 26th Street, N. Y.
BOSTON Branch: 819 Tremont Building
PHILADELPHIA Branch: 1215 Filbert St.



Why U-Bar Greenhouses Excel

Then there is the downright practical side of U-Bar houses, the side that means more flowers, or vegetables of finer quality with less care and expense than in any other houses constructed any other way. The reason for this is, in short — *more light*. You see there is no gutter at the eave — no heavy members — the glass is spaced 24 inches instead of 16 inches. Every structural detail has been reduced to the smallest possible point. Still with all this extreme lightness of construction, there is not a more rigid, enduring house made — and it is the U-Bar that does it. The catalog although filled with U-Bar houses, both exteriors and interiors, also shows plans, sections and all the interesting structural details that you like so well to know—Send for it



U-BAR GREENHOUSES

PIERSON U-BAR CO.

Designers and Builders

1 Madison Ave., New York

HORTICULTURE

Vol. VII. FEBRUARY 29, 1908 No. 9



AN ARBOR OF BOUGAINVILLEA GLABRA

Devoted to the
**FLORIST, PLANTSMAN,
LANDSCAPE GARDENER,
and
Kindred Interests**

Published
EVERY SATURDAY
At 11 Hamilton Place,
BOSTON, MASS.
Subscription, \$1.00

MAR 2 1908

CANNA BULBS

Fine plump, Northern Grown, and in fine condition. Not to be compared with southern grown stock, that are never thoroughly ripened and therefore are very slow to start growing.

	Doz.	100	1000		Doz.	100	1000
Allemania	\$0.35	\$2.50	\$22.50	Gladiator	\$0.40	\$3.00	\$27.00
Black Prince	.40	3.00	27.00	King Edward	.50	3.50	32.00
Black Warrior	.35	2.50	22.50	Louisiana	.55	4.00	35.00
Burbank	.30	2.25	20.00	Mad. Crozy	.40	3.00	27.00
Black Musafolia	.40	3.00	27.00	Mlle. Berat	.30	2.25	20.00
Charles Henderson	.35	2.50	22.50	Musafolia	.30	2.25	20.00
Director Roe z	.35	2.50	22.50	Paul Marquant	.30	2.25	20.00
Flamingo	.30	2.25	20.00	Pres. McKinley	.35	2.50	22.50
Florence Vaughan	.35	2.50	22.50	Queen Charlotte	.35	2.50	22.50
Golden Star	.30	2.25	20.00	Robusta	.30	2.40	18.00
				Red Cross	.30	2.25	20.00

STUMPP & WALTER CO., 50 Barclay St., NEW YORK

GERANIUMS.

Our New Illustrated Catalogue Mailed to the Trade. An immense stock of plants in 2 in. pots ready for immediate shipment \$2.00 per 100; up to \$1.00 each. Our selection of 20 good varieties, \$18.50 per 1000. New Varieties 1005-6 introduction, one plant each of 50 kinds, \$5.00. 1007 Novelties, Bruants, Cannells, Bouchard and Lemoine introduction, one each of 50 kinds \$10.00.

	Per 100		Per 1000
Pelargoniums, good strong plants from 3 in. pots	\$6.00	Fuchsias, Black Prince and Minnesota	2.00
Ivy Leaved Geraniums. We have a surplus of about 1000 in good strong plants of 3 varieties, White, Red and Light Pink, which we offer at \$18.50 per 1000, \$2.00 per 100 to move them quick as long as the surplus lasts		Lieutenant Muritz, White and Rose Phenomenal	2.50
Dahlia Roots, 100 varieties whole field clumps	5.00	Hardy English Ivy, Extra Strong, \$15.00 per 1000	\$2.00
Hardy Chrysanthemums, 75 var.	2.00-3.00	Hollyhocks, Strong 3 in. pot plants, dbl. white, pink, red and yellow	3.00
Alyssum, Giant Double	2.00	Lobelia, Crystal Palace Gem	2.00
Cuphaea, Cigar Plant	2.00	Panicum, Variegated, Handsome basket plants	2.00
Coleus, Verschaffeltii, Golden Bedder and other kinds	2.00	Tradescantia, Dark Variegated	2.00
Swainsona, Alba	2.00	Verbena, Red, White, Purple and Pink	2.00
		Caladium, Esculentum, 1st size \$2.00 per 100; 2nd size	1.00
		Lavender, 2 1/2 in. pots strong	3.00
		Lantanas, 5 varieties	2.00

R. VINCENT JR. & SONS COMPANY, White Marsh, Md.

NEW A MONEY MAKER NEW CARTER'S DOUBLE BLUE LOBELIA

2 in. pots, \$1.00 per doz.; \$7.00 per 100

CASH WITH ORDER PLEASE. **J. FULLER, 31 Orchard St., LEOMINSTER, MASS.**

AZALEAS

for fall delivery, the best that are grown, also **PALMS** for spring or fall delivery, furnished by August Haerens, Belgium; orders booked now.

ADDRESS THE AMERICAN REPRESENTATIVE: **AUGUST ROLKER & SONS, 31 Barclay Street, or P. O. Box 752, New York**

CANNAS

Send for our List and Prices

The **CONARD & JONES CO.**
WEST GROVE, PA.

Herbaceous Perennials

A complete stock of the most desirable of the standard varieties.

RED OAK NURSERIES
FISKEVILLE, R. I.

ROBERT CRAIG CO.

ROSES, PALMS,

and Novelties in Decorative Plants

MARKET and 49th STREETS., PHILADELPHIA, PA.

Just Received in Splendid Condition

15,000 AZALEAS

in all sizes and varieties

25c. up to \$2.00 each

Also Kent as, Rubbers, Araucarias, Pandanus, Boxwood, Euonymus, Crotons, Areca and Eurya latitolia.

Extra good value in large

Specimen and Decorative Palms

A. LEUTHY & CO.

Perkins Street Nurseries, Roslindale, Mass

GODFREY ASGHMANN

Importer and Wholesale Grower and Shipper

of Araucaria Excelsa, Compacta, Robusta and Glauca; Kentia Forsteriana and Belmoreana Azalea, Indica, etc. Cultivator of Boston, Scottii, Barrowsii, Elegantisima and Whitmanii Ferns. Ferns for dishes, Cocos, etc. Write for prices.

1012 Ontario St., Philadelphia

1/4 MILLION CANNAS

**Good Tubers 2 to 3 Eyes
TRUE TO NAME**

ORDER NOW FOR DELIVERY ANY TIME

Red and Crimson Cannas

	Doz.	100	1000
Louisiana, 7 ft. high, 100, each	\$1.00	\$10.00
A. Bouvier, 5 ft.	.35	2.25	\$20.00
Beaute Poitevine, 3 1/2 ft.	.35	2.25	20.00
Chas Henderson, 4 ft.	.30	2.00	17.50
Crimson Bedder, 3 ft.	.35	2.25	20.00
Duke of Marlborough, 4 1/2 ft.	.35	2.75	25.00
J. D. Eisele, 5 ft.	.35	2.25	20.00
Explorateur Crampel, 5 1/2 ft.	.30	2.00	17.50
Express, 2 to 2 1/2 ft.	.60	4.50	40.00
Flamingo, 4 1/2 ft.	.30	2.00	17.50

Pink Cannas

L. Patry, 4 1/2 ft.	.35	2.25	20.00
Luray, 3 ft.	.35	2.25	20.00
Louise	.35	3.50	25.00
Mlle Berat, 4 1/2 ft.	.35	2.25	20.00
Tennyson, 5 1/2 ft.	.50	3.00

Orange Scarlet Cannas

Pres. Cleveland, 4 ft.	.35	2.25	20.00
------------------------	-----	------	-------

Red, Gold-Edged Cannas

Indiana, 3 to 4 ft. high, 15c. each	1.50	10.00
Mme. Crozy, 5 1/2 ft.	.40	2.75	25.00
Souv. de A Crozy, 4 ft.	.40	2.75	25.00
Premier, 2 1/2 ft.	.35	2.25	20.00

Yellow Cannas

Buttercup, 3 1/2 ft.	.75	4.25	40.00
Comte de Bouchard, 4 1/2 ft.	.35	2.25	20.00
Florence Vaughan, 5 ft.	.50	2.75	25.00
L. E. Bailey, 4 1/2 ft.	.30	2.00	17.50

Bronze-Leaved Cannas

Brandywine, 4 to 5 ft.	.35	3.50	25.00
Black Beauty, 5 ft.	.50	2.75	25.00
David Harum, 3 1/2 ft.	.50	3.25	30.00
Egandale, 4 ft.	.50	2.75	25.00
Leonard Vaughan, 4 1/2 ft.	.50	2.75	25.00
Musafolia, 8 ft.	.35	2.25	20.00
Robusta, 6 to 8 ft.	.30	1.75	15.00
Shenandoah, 6 ft.	.35	2.25	18.00
Stadrath Heidenreich, 4 1/2 ft. 20c. each	2.00	15.00

Orchid Cannas

Allemania, 4 to 5 ft.	.35	2.25	20.00
Austria, 5 ft.	.31	1.75	15.00
Italia, 4 1/2 ft.	.35	2.25	20.00
King Humbert, 4 ft.	1.25	10.00	80.00
Kronus, 5 ft.	.35	2.25	20.00
Mrs. Kate Gray, 6 ft.	.35	2.25	20.00
Pennsylvania, 5 ft.	.50	2.75	25.00

All above Cannas packed 250 in a case. Full case at 1000 rate; 25 at 100 rate.

Caladiums Esculentum

(Elephant's Ear)

Bulbs 6 to 8 in. circum.	.25	1.50	10.00
Bulbs 8 to 10 in. circum.	.50	3.50	30.00
Bulbs 10 to 12 in. circum.	.75	5.50	50.00
Bulbs 12 to 13 in. circum.	1.00	8.00	75.00
Monster Bulbs measuring 12 in. and upwards in circum. \$1.50 per doz.; \$12.00 per 100.			

Our Wholesale Catalogue of Quality seeds and bulbs now ready. It contains forty pages of seeds and bulbs you need fully described. Write for it today—a postcard will fetch it.

ARTHUR T. BODDINGTON SEEDSMAN

342 W. 14th St., New York City

CARNATION CUTTINGS

We are in unusually good position to supply exceptionally well-rooted, healthy stock. We have such a large quantity of flowering plants that we propagate only from heel cuttings from flowering shoots. Our cuttings are rooted in light, sunny, airy houses, and we are sure will satisfy the most critical buyer. A prominent carnation grower writes, "You seem to be the only firm in the business that knows how to pack stock and have it reach the buyer in good condition, and I have always found your cuttings cheaper than the same varieties from others at much lower figures." While our prices may not always be the cheapest, we certainly can give, quality considered, as good value as, if not better than, is obtainable anywhere.

WINSOR which we introduced last year has proved to be the finest novelty introduced in years. We think it is the most profitable variety grown today, considering its fine color, splendid keeping qualities, and productiveness. When properly grown, it leaves little to be desired, and almost every one succeeds with it.

WHITE ENCHANTRESS the best all-round white carnation, on account of its large size, long stem, earliness, and productiveness. Our White Enchantress, exhibited at the Carnation Convention at Washington, was the only White Enchantress exhibited that received an award.

Strong rooted cuttings, now ready for delivery, from sand \$6 per 100, \$50 per 1000; from soil, \$7.50 per 100, \$60 per 1000.

We offer also **Beacon** and **Red Chief**, from sand, \$6 per 100, \$50 per 1000; from soil, \$7.50 per 100, \$60 per 1000. Also **Victory**, **Melody** and **White Perfection** from sand, \$4 per 100, \$35 per 1000; from soil, \$6 per 100, \$45 per 1000. **Variegated Lawson**, **White Lawson** and **Red Lawson**, from sand, \$3 per 100, \$25 per 1000; from soil, \$4 per 100, \$35 per 1000. We can supply, also, **Winona** and **Afterglow** at \$12 per 100, \$100 per 1000.

Buyers will find transplanted stock offered from soil well worth the difference in price

F. R. PIERSON CO., - - **Tarrytown-on-Hudson, NEW YORK**

WINSOR and WHITE ENCHANTRESS *Immediate Delivery*

From sand \$6 per 100, \$50 per 1000; from soil \$7.50 per 100, \$60 per 1000; from pots \$9 per 100, \$75 per 1000

Satisfaction Guaranteed. WHITE BROS., Gasport, N. Y. Try Us.

Rooted Carnation Cuttings

<u>Pink</u>	100	1000
Aristocrat.....	\$6.00	\$50.00
Winsor.....	6 00	50.00
Rose Pink Enchantress	3.50	30.00
Enchantress.....	3.00	25.00
Lawson.....	2.50	20.00
Joost.....	2.00	15.00
<u>White</u>		
White Perfection.....	3.00	25.00
" Lawson.....	3.00	25.00
Queen.....	2.00	18.00
Boston Market.....	2.00	18.00
Louise.....	2.00	18.00
Lt. Peary.....	3.00	25.00
Bountiful.....	2.50	20.00
<u>Red</u>		
Beacon.....	6 00	50 00
Victory.....	3 00	25 00
Robert Craig.....	3 00	25 00
Flamingo.....	2 50	20 00

<u>Miscellaneous</u>		
Patten.....	2.50	20.00
Harry Fenn.....	2.50	20.00
Harlowarden.....	2.50	20.00

Stock Guaranteed—Prompt Deliveries

THE LEO NIESSEN CO.
WHOLESALE FLORISTS
1209 Arch St., PHILADELPHIA

JOHN E. HAINES *Bethlehem, Pa.*

is the place to order rooted-cuttings of the following varieties for 1908.

John E. Haines, red imperial variegated	} Per 100 Per 1000	} \$6.00 \$50.00
Pink Imperial, Pink Enchantress, Light Pink		
Place your orders early for Jan. delivery.		

CARNATIONS ROOTED CUTTINGS

Winona, color, true clear pink, comes nearest to Fiancee but a different type flower. Growth on order of Scott but vastly improved in every respect. Early flowers in quantity and on long stems. Does not burst its calyx. Fine, shapely, active growth. In color and productiveness it is without an equal. Orders booked now and filled in strict rotation. \$12 per 100, \$100 per 1000.

White Perfection, pure white. We have a large stock. \$3 per 100, \$25 per 1000.

F. DORNER & SONS CO.
LA FAYETTE, IND.

CARNATIONS WHITE ENCHANTRESS R. C.

This stock originated with and grown by me is the very best.

\$6.00 per 100, \$50.00 per 1000.

	Per 100	Per 1000
Enchantress, light pink.....	\$2.50	\$20.00
Lawson.....	2.00	15.00
Lord, light pink.....	2.00	15.00
Queen, white.....	2 00	15 00
The Belle, white.....	2.50	20.00

250 at 1000 rate. Orders of 1000 or more will be shipped prepaid on receipt of check.

Get your R. C. early and have blooms when others have none.

FRANK H. KIMBERLY
631 Townsend Avenue, NEW HAVEN, CONN

100,000 DAHLIAS

Premium Stock, guaranteed true to name. 500,000 large Flowering Gladiol, hundreds of colors and variations mixed. Wholesale prices on application. Order now for spring delivery. Catalogue free.

J. L. MOORE, Northboro, Mass.

DAHLIAS. Now is the time to place your order for bulbs which will insure you getting named varieties in any quantity; prompt delivery.

DAVID HERBERT & SON,
Successors to L. K. Peacock, Inc.
ATCO, N. J.

LLOYD IS THE REAL THING The Carnation for every one to grow

LLOYD is a commercial white, with a fancy flower

The only ever-blooming, large-flowering white in existence

Will take the place of all other whites now in commerce. Every New Bedford grower has bought stock. Come and investigate.

**A KEEPER
A SHIPPER
A BLOOMER**

It will bring the shekels when all others fail

\$2 pr 12. \$12 pr 100. \$100 pr 1000

Unrooted Cuttings
\$6 per 100. \$50 per 1000.

H. A. JAHN
NEW BEDFORD, - - MASS.

Carnation Cuttings

Both standard varieties and novelties. Stock guaranteed to be first-class. Address,

S. S. SKIDELSKY

1741 North 18th Street, Philadelphia

ROOTED CARNATION CUTTINGS

Only the Best Varieties

CHICAGO CARNATION CO., JOLIET ILL.

NEW "My Maryland" ROSE

Best up-to-date commercial rose; read what others have to say about it.

The Gardeners' and Florists' Club of Boston:—A Report of Merit is Hereby Awarded to JOHN COOK For Vase New H. T. Rose No. 294 since named "MY MARYLAND."

Description and points of particular merit: This New Rose has a pleasing shade of Salmon pink. With other essential characteristics of a good commercial Rose fully proven, much may be expected of it. The Committee believes this variety will be especially valuable in the Light Pink Class of Winter blooming roses. Given by the Gardeners' and Florists' Club of Boston this 17th day of December, 1907. SIGNED: W. N. CRAIG, Secy.

Price 2 and 2½ inch pots, \$25 per 100; \$200 per 1000. Price 3 inch pots, \$5 per dozen.

JOHN COOK, 318 North Charles St. Baltimore, Md.

BUY IN SEASON

Seedlings and Rooted Cuttings, extra fine, well rooted; three grades, just right for lining out: *Magnolia Glauca* (Sweet Bay), *Ampelopsis robusta purpurea* (New), *Ibota Privet* (Jap.), *Berberis Thunbergia* (Jap.), *Berberis Vulgaris* (Native) *Arborvitae* American and Siberian, Spruce, White Pine and Hemlock.

It will pay you to get our prices NOW

PIERCE NURSERY
BEVERLY FARMS, MASS.

Hardy Roses

American Grown—Superior to Imported

We have unsold at the present time the following varieties—all field grown plants, grown in our nurseries at Rochester, N. Y.:

Anne de Diesbach	Prince Camille
Cllo	Ulrich Brunner
Franz Karl Druschki	Crimson Rambler
General Jacqueminot	White Rambler
John Hopper	Yellow Rambler
Mme. G. Lutzet	Philadelphia Rambler
Marshall P. Wilder	Common Sweet Briar
Mrs. John Loring	Mme. G. Bruant
Paul Neyron	Wichurlanu (The Type)

These plants are in our storage cellars and can be shipped at any time. Prices on request.

ELLWANGER & BARRY

Nurserymen—Horticulturists

Mount Hope Nurseries, Rochester, N. Y.

Hardy Rhododendrons Azaleas Conifers, Clematis, H. P. Roses, Shrubs and Herbaceous Plants from our **HOLLAND NURSERIES**

Prices Moderate

P. OUWERKERK, 216 Jane St., Weehawken Heights, P. O. No. 1, Hoboken, N. J.

AMERICAN NURSERY COMPANY
COMBINING

FRED'K W. KELSEY, New York City
F. & F. NURSERIES, Springfield N. J.
BLOODGOOD NURSERIES, Flushing L. I.
N. J. & L. I. NURSERIES.

We Can Supply Your Every Need. Write for Prices
SALES DEPARTMENT, 150 Broadway, New York.

Established 40 Years

Rose Hill Nurseries

New and Rare Plants

NEW ROCHELLE, N. Y.

New York Office, Siebrecht Building, 425 Fifth Avenue

BARGAINS in TREES and PLANTS

Six for 25c., delivered free by mail

List Free. D. J. TWOMEY, Dept. H., Geneva, N. Y.

TAUSENDSCHON

or in English **Thousand Beauties**, is the sensational new Climbing Rose of the year. Every florist should have it. It is not excelled for forcing purposes and for general planting by any Climbing Rose now known, **not even bearing Crimson Rambler**. This is the coming forcing Rose. Get your stock early. Illustrated in ten colors and gold in our Catalogue for 1908, the **Leading Rose Catalogue of America**. Every Rose worth having is described in it. Copy free for the asking.

Strong plants of Tausendschon from 3-inch pots, 10 for \$1.50; \$12.00 per 100; \$100.00 per 1000.

THE DINGEE & CONARD CO., WEST GROVE, PA.

RHODODENDRONS, ANDROMEDAS, KALMIAS AND SPECIMEN EVERGREENS

JOHN WATERER & SONS, LD.

AMERICAN NURSERY

BAGSHOT, - - - ENGLAND

HARDY NORTHERN GROWN NURSERY STOCK

At Reasonable Prices

FRUIT AND ORNAMENTAL TREES, SHRUBS, VINES, ROSES AND HERBACEOUS PERENNIALS IN GREAT VARIETY

Catalogue and Price List for the asking

BAY STATE NURSERIES, NORTH ABINGTON, MASS.

NEW NEW

RAMBLER ROSE "NEWPORT FAIRY"

To be disseminated Spring, 1908. Ask for Illustrated pamphlet and prices

JULIUS ROEHRS CO., Rutherford, N.J.

SPECIMEN EVERGREENS

Box Plants, Azaleas, Rhododendrons, Roses, Herbaceous Perennials

In fact everything in hardy stock for Garden, Lawn and Landscape Planting. General Catalogue and Trade Lists on application.

The NEW ENGLAND NURSERIES, Inc., Bedford, Mass.

TO BUYERS

Patronize our advertisers. they will treat you right

Bougainvilleas

(See Frontispiece)

The Bougainvilleas are natives of South America and it is there that one sees them in their greatest perfection. There are said to be seven species belonging to this showy genus, but there are not more than two species and several varieties in common cultivation.

They are especially valuable when trained as greenhouse or palm house climbers, and will cover the roof and walls to a height of twenty-five or thirty feet. The side branches from one plant when trained out horizontally will cover twenty to thirty feet if desired. When grown in this way they are usually kept dry during the early part of the winter. About this time or early in March the plants are given a thoroughly hard pruning, cutting back the growth of last year to within one or two buds of the older wood and cutting out all weak and undesirable parts. If they are grown in a border the top soil to the depth of several inches may be removed and a top dressing of good turfy loam and cow manure given. If the plants have been kept thoroughly dry a good soaking of water may be given at this time, but afterwards they must be watered sparingly until there is enough new growth to warrant more liberal supplies. By the middle of next May, if the plants are treated as directed, they will have branches three or four or more feet in length and completely covered with large showy bracts. We find these long sprays very serviceable when cut for Class Day and Commencement decorations.

The species that is most commonly grown is *Bougainvillea glabra*. It is very easy to grow and flowers most profusely and has showy bright rosy red bracts.

Bougainvillea glabra variety *Sanderiana* is a much more compact plant than the species and on that account is better suited for pot culture and when well grown makes a capital Easter plant.

Bougainvillea spectabilis is a showy plant but not as easily grown as the above-named species. Sometimes it is very hard to make it bloom successfully. Well do I remember a fine specimen of this species which grew most luxuriantly in the vestibule to the water-lily-house at the Royal Gardens, Kew. Although this plant made magnificent growth it could not be made to flower satisfactorily until it was dug up and most of the roots cut off and replanted in not over-rich soil. Then for some years afterwards this plant flowered splendidly. This species when well blossomed is a most magnificent sight and is much more showy than *B. glabra*. It has large panicles of flowers and large showy bracts of a deep rose color varying to purple.

There is a variety of this plant which is extremely showy and distinct, known as *B. spectabilis* var. *laterita*. This variety is strikingly distinct from any other bougainvillea in cultivation. The habit and form of the plant is very similar to the ordinary kinds. It is the color of the bracts, which is of a brick red, that makes it look so different from all other bougainvilleas. Because this variety is rather hard to propagate it is not as frequently seen as it deserves. The finest specimens I have ever seen of this variety are in Hope Gardens near Kingston, Jamaica, British West Indies. They are grown in large bush form and are at their best in the month of January. They make such an imposing show and the sight makes such an impression that one can never forget it. The Jamaicans propagate this plant by pot-layering; that is, a branch is "ringed" or "girdled" and a bamboo pot which has been divided is put around the part girdled, filling up with soil, and

left in this way until roots are formed. This is the only way they can increase this variety. This distinct variety on account of its showy bracts would make an excellent florists' plant for Christmas.

All other kinds of bougainvilleas are easily increased by cuttings of the half ripened wood. If treated properly in pots and brought along at the right time bougainvilleas would make imposing bedding plants for places like Boston Public Garden and the flowers and bracts would last two months in good condition.

Green fly and mealy bug are two of the worst insects that trouble these plants when they are grown in green houses. The former can easily be destroyed by fumigating with tobacco or Aphis Punk, and the latter when the plants are pruned should be thoroughly syringed with kerosene emulsion.

The scene pictured in the frontispiece of the paper is one that is admired by every person who is fortunate enough to see this wonderful arbor when it is in full perfection during the winter months. It is three or four hundred yards in length and leads up from the street to the main entrance of the Constant Spring Hotel, Jamaica. *Bougainvillea glabra* is the kind that is used on this handsome arbor. One can easily imagine how cool and refreshing it is to walk under a canopy like this in a hot tropical country.



Viburnum opulus Linn.

Another shrub of marked worth because of the beauty of its fruit is the High Bush Cranberry, which is native to our own northern States and Canada as well as to parts of Europe and Asia. It is an upright shrub of robust habit ultimately attaining a height of eight to ten feet. The foliage is good but of no special merit. In summer it is dull green and in autumn it becomes purplish or dull red. The flowers, which appear in late May or early June, are borne in broad flat cymes that are three or four inches in diameter. The perfect flowers, composing the greater part of the inflorescence, are small, white and about one-quarter of an inch across. The outer neutral flowers, which are the really showy ones, are white and nearly three-quarters of an inch in diameter.

The fruit that follows is particularly attractive. When fully grown it is at least a half inch in length. It begins to turn by early August and early in September has become bright scarlet. Normally it hangs on and is showy throughout the winter and not infrequently until early spring.

Like many of the viburnums this can not be classed with the rapid growing shrubs, yet it proves satisfactory in any good soil. It is comparatively free from disease or insect troubles, although it is occasionally disturbed by the leaf curl. However, this is never so serious as in the case of the sterile-flowered form, the Guelder Rose or Snowball. Because of its habit, its flowers and its good scarlet fruit it is desirable for any shrubbery and is especially deserving of place among the best shrubs. In the shrubbery border shown in the frontispiece of last week's issue the white cymes of *Viburnum opulus* are effectively shown.



HORTICULTURE

VOL. VII FEBRUARY 29, 1908 NO. 9

PUBLISHED WEEKLY BY
HORTICULTURE PUBLISHING CO.
 11 Hamilton Place, Boston, Mass.
 Telephone, Oxford 292
 WM. J. STEWART, Editor and Manager

SUBSCRIPTION PRICE
 One Year, in advance, \$1.00; To Foreign Countries, 2.00; To Canada, \$1.50
ADVERTISING RATES
 Per Inch, 30 inches to page \$1.00.
 Discounts on Contracts for consecutive insertions, as follows:
 One month (4 times) 5 per cent.; three months (12 times) 10 per cent.;
 six months (26 times) 20 per cent.; one year (52 times) 30 per cent.
 Page and half page spaces, special rates on application.

Entered as second-class matter December 8, 1904, at the Post Office at Boston, Mass., under the Act of Congress of March 3, 1879.

CONTENTS

	Page
FRONTISPIECE—Arbor of Bougainvillea glabra.	
BOUGAINVILLEAS—Robert Cameron	261
VIBURNUM OPULUS—David A. Clarke.....	261
PINUS ARISTATA—C. S. Harrison.....	263
CLIANTHUS PUNICEUS—K. Finlayson.....	263
AFTER ADJOURNMENT	264
APPLES IN THE NORTHWEST.....	264
NEWS OF THE CLUBS AND SOCIETIES:	
Gardeners' and Florists' Club of Boston—Chrysanthemum Society of America—American Rose Society	265
Illinois State Florists' Association—New Orleans Horticultural Society—Southampton Horticultural Society—New York Florists' Club—National Flower Show Committee—Twin Cities Florists' and Gardeners' Club—Club and Society Notes.....	266
COMMERCIAL CARNATIONS—Wallace R. Pierson..	266
CARNATION BREEDING IN AMERICA—C. W. Ward.	267
SEED TRADE	270
OBITUARY—William McManus—James Daly—Robert Allan	274
GREENHOUSE GROWN VEGETABLES—Illustrated..	272
FLOWER MARKET REPORTS:	
Boston, Chicago, Detroit, New York, Philadelphia, Washington	277
SMALL FRUITS—Wilfrid Wheeler.....	285
MISCELLANEOUS:	
Heard at Dingee & Conard Co.'s.....	264
Personal	264
Movements of Gardeners.....	269
Catalogues Received	270
\$250,000 for Gypsy Moth Fight.....	270
List of Patents.....	271
News Notes	274
Fire Record	274
Business Changes	275
New Retail Flower Stores.....	275
Carnation Lieut. Peary.....	277
Greenhouses Building or Projected.....	277
Philadelphia Notes	277

The carnation growers' burden

The present depression in market values of many standard varieties of cut flowers, unusual in its extent over the greater part of this country, brings to the front questions of grave importance to the grower and, although in somewhat lesser degree, to the flower dealer, the bulb importer and the greenhouse builder. Naturally, comparisons are made between returns for flowers marketed this season and prices realized at corresponding dates last year and in years previous. In this light, carnations, for instance, make a very poor showing, although, so far as quality is concerned, the average product this year is equal to, if not superior to, anything ever before offered. Concealing this fact as to quality the break of from thirty to sixty per cent., or even more in some cases, in prices

for February as compared with those prevailing one year ago must come as a serious disappointment to the carnation growers, a disappointment which the heavier aggregate cut of blooms during this period will not greatly lessen. It is to be hoped that as the season progresses some compensating balance on the other side may yet be experienced and a better general average thus reached than now seems likely, for no class of flower growers has better earned a substantial reward for intelligent industry than have the American carnation growers.

The forcing bulb industry

Undoubtedly the man who has occasion to view the situation with the greatest apprehension is the one engaged in bulb forcing. The market value of this particular product, including lily of the valley, has run of late on the average dangerously near the first cost of the bulbs and not infrequently the returns for the flowers have been considerably below the cost of the bulbs. This cannot go on indefinitely and bulb importing houses, as well as the foreign firms making direct shipments, should prepare themselves for a curtailed demand for next season while those who were over-indulgent in giving credits last fall may have to take some painful jolts. Direct information by cable this week is to the effect that higher prices are contemplated for all French bulbs for the coming season and quotations on deliveries are thus far unobtainable. Considering the experiences of the present forcing season the attitude of American bulb buyers, in the event of higher import prices, should not be a matter of conjecture. The fact that the forcing bulb crop is with a good many growers a sort of filler-in between other crops and that it is not easy to find any other use for the houses in midwinter is not likely to have much weight if the business must be done at an actual cash loss to the grower.

Old style houses at a disadvantage

Some views of the violet-growing question as affected by this year's market conditions and tendencies, as same appears to us, were given in our issue of two weeks ago. A few thoughts on the rose may not be untimely. The rose has been one of the few bright spots in this listless flower season, up to date. There have been seasons in the past when the rose grower has had to face a much worse proposition than anything that has confronted him thus far this year. The explanation is to be found, undoubtedly, in light crops. Indications now favor an increased supply for the weeks to come and with the incoming of Lent and the fact of a late Easter, heavy surplusses seem inevitable. One thing that should not be lost sight of is that the great majority of roses, and, to a considerable extent, of carnations also, which have the quality necessary to find an appreciative market now-a-days come from establishments having modern-type houses. Conditions are rapidly approaching that stage where a living income can no longer be easily extracted from the growing of roses in any but the modern light and spacious type of house and the rose grower limited to equipment which, a dozen years ago, was ample and remunerative will then be at a great disadvantage. Cultural ability is, of course, an indispensable factor in any case, but cultural ability confined in inadequate houses is badly handicapped when forced to compete against equal cultural skill backed by the modern "rose factory" outfit. If we mistake not, the up-to-date greenhouse builder has lively times in store for him in the near future.

Pinus aristata—Foxtail Pine

It is strange that this unique and charming tree has not been more extensively propagated. Isaac Pollard of Nehawka, Nebraska, has a fine specimen and we find now and then one growing in different parts of the country and there is no reason why they should not be grown more extensively. People little realize what a wide diversity of beauty and attractiveness a large variety of evergreens will give us. Each seems to have an individuality of its own. A single species will branch out into many divergent forms and variations. The Douglas Spruce for instance, has about fifty named varieties.

Pinus aristata is often called Bristle Cone Pine and sometimes Hickory Pine. I can not forget the first one I ever saw. My friend and myself had been climbing mountains till we were completely tired out. We were at an altitude of about 9000 feet among the Engelman and Pungens Spruce. We were lying down in utter exhaustion. In the distance, we saw a pine different from anything we had seen before and we thought we knew every tree in the Rockies. Our curiosity got the better of our weariness and we went to interview our new acquaintance. We lay down on a hillside near by to look the tree over, and then we both broke out into a hearty laugh. "What can it be?" asked my friend. "Haven't you ever heard of the Foxtail Pine? Here we have it." It seemed as if hundreds of foxes had rushed to a common center, all headed toward the stem of the tree and their tails had all turned green. How we laughed and laughed again over that strange spectacle which seemed half tree and half animal. Higher up, we found a grove of them. The same kind with different ages and slightly different forms. Some little, some large—grandmothers, children, and grandchildren. Farther up, in higher altitudes, we found quite a forest of them. Our collectors in the Rockies expect to secure a large amount of seed and a lot of seedlings for the Nebraska Experiment Station at York, next year. It is fortunate that a fine tree like this, growing at such a high elevation, can endure the heat of our western prairie. There is no reason why nurserymen cannot grow these by the thousands, and so add to the number of the beautiful evergreens with which we can adorn our homes.

One thing we find and that is we cannot raise all kinds of evergreens successfully in the peculiar soil and climate of Nebraska. The Engelman and Colorado Blue Spruce can not be raised successfully here. So we have started a branch nursery at Paynesville, Minnesota, under the care of Frank Brown, who goes into his forests and digs up beds and plants the seeds in the leaf mould and there he is meeting with wonderful success. All these high altitude trees will be successful in the North.

The *Aristata* of the western slope is one of the most charming trees of the Sierras. The needles are clothed with a glossy sheen or polish—often with a silvery tinge. Sometimes there will be one of ideal form, with straight trunk, from which branches extend in pyramidal form, in beautiful symmetry from the crown to the earth, all those outer limbs harmoniously dressed in beautifully rounded glistening foliage. Some trees have been found on the western slope that were five

feet in diameter and ninety feet tall, but this is exceptional.

I am not familiar with the wood of this tree but judge from the name, Hickory Pine, which is sometimes given it, that it must be the toughest of all the pines.

C. S. Hamman

York, Neb.

Clianthus puniceus

This beautiful cool greenhouse subject I have never had the opportunity of laying my eyes on since my apprenticeship days in the north of Scotland, and have ever wondered since that such a beautiful, even gorgeous flowering climber, should thus far have been overlooked by our enterprising plant importers. That it is practically unknown in plant collections on this side of the Atlantic is pretty nigh conclusive, as there is hardly, if any, reference made to it in our horticultural literature.

Unlike *C. Dampieri*, the former is an easily grown subject and entirely devoid of the milky characteristics associated with *Dampieri*, yet the latter is far more widely known, doubtless on account of its more gorgeous flowers, the dark purple spot so conspicuous on the standards of the flowers adding much to its effectiveness; otherwise they are of equal showiness, the flowers of both being scarlet.

C. puniceus possesses robust growth habits, and somewhat resembles in vine, growth and leafage the well known *Swainsona*, only a little larger and stouter in its parts. Its peculiar parrot-bill flowers are freely produced in bunches containing many flowers. It is not fastidious as to special soils yet good friable soil as that is understood will play an equally important part in its successful management as it really does with other plants. Planting out in suitable narrow borders is the easiest and best way for arriving at effective displays, as indeed it is with most all strong-growing climbing subjects, and notwithstanding what may be done in other methods, such as ample pot or tub culture, very fine results may thus be produced. Red spider is partial to these plants, but no excuses can be offered for red spider mastering the cultivator so far as *C. puniceus* is concerned, for it can withstand syringing or hosing to any reasonable extent and feel the better for it.

This, however, must be somewhat modified as regards *C. Dampieri*; although moisture must be present to ward off red spider or thrips, it is best applied in the evaporated form; frequent syringings according to weather conditions within the precincts of the plants, with an additional absorbent material strewn around them, particularly tobacco stems, will accomplish the necessary remedy. The leaves of the latter variety being soft and woolly in texture do not take kindly to over-head shower baths. It is best to grow this variety from seeds annually, while *C. puniceus* can be raised from cuttings in the general manner. The latter is frequently used as a stock plant for grafting the other on, for the purpose of overcoming the aforesaid milfulness of character, root disturbance being one of its dislikes.

W. D. Burdison

AFTER ADJOURNMENT

We don't believe in green carnations or any other dyed blossoms and regard the indulgence in such monstrosities as a disgrace to the florist business. We do believe in the shamrock, however, as a beautiful little emblem of St. Patrick's Day. Many more of these plants might be sold. See advertisements of these in this issue. These people have the "rale thing."

We extend congratulations to the floral fraternity of Hoboken and contiguous New Jersey territory on the opening of transportation through the new "tube" under the broad Hudson River by which quick and sure access to New York markets is at last assured. No longer can New Jersey be classed as a foreign country. John Birnie and his loyal German clan are now in the United States, glory be.

When a man of such literary prominence as W. D. Howells assumes responsibility for the absurd statement quoted in our seed trade column in this issue, it would seem that in providing horticultural instruction for the public school children we are not going far enough. Why not establish night schools where people such as Mr. Howells, whose opinions carry weight with the public, may have an opportunity to learn a few of the first principles of botanical science and acquire a bit of commonsense concerning plant life?

H. Suzuki of Yokohama, Japan, who is visiting this country for the first time in fifteen years tells us that there are no less than five hundred private conservatories in the neighborhood of Yokohama and Tokio all built within the past few years and the demand for orchids and other conservatory material is increasing so rapidly that within five years it is expected that the number of establishments devoted to their culture will equal that of the most favored districts of England. Horticulture in Japan is evidently very much up-to-date.

They were alone in the conservatory, says the Cleveland Plain Dealer. He turned to her. His voice was low, but passionate.

"You know," he said, "why I have asked you to come here. Will you be my wife?"

She looked at him intently.

"No," she answered, and she uttered the monosyllable as if she loved it.

No doubt she expected him to reel and clutch at something, but he did nothing of the sort.

"Very well," he briskly said, "that's all I want to know. Shall we go in and finish our dance?"

She stared at him in wonder.

"Aren't you hurt by my refusal? Don't you intend to do something desperate?"

"Desperate? Certainly not. Unless you call tackling the lobster salad desperate."

Her pride was sorely wounded. She had meant to hurt him. It would have been a proof of her power. Now she hungered for revenge. There was only one way to get even with him.

"George," she said, "I have reconsidered my decision. I will be your wife."

And the two scrawny rubber plants and the three yellow palms quivered with suppressed laughter.

The rubber plants and the palms do occasionally get a chance at something worth seeing and hearing. But it's in order for the Cleveland florists if there are any left in that town, to take

steps to eliminate the "scrawny" and "yellow" relics from the sight of the Plain Dealer man.

APPLES IN THE NORTH WEST.

Pomologists and geologists alike agree that the soil of the Spokane country, especially in the valleys, is remarkably rich and almost inexhaustible and adapted to the successful growth of all kinds of fruits, and, to emphasize this fact it may be noted that the district produced \$14,000,000 worth of commercial fruits, more than 60 per cent. of which was in apples, in 1907. The importance of this branch of the industry will be better appreciated when it is known that almost 100,000 acres of land, or more than four full townships, were devoted to apples alone last year, which shows an increase of from 20 to 30 per cent. in bearing trees over 1906. The coming year will show a gain of 27 per cent., while that for 1909 is estimated at from 50 to 75 per cent. and more than 100 per cent. in 1910. The value of the fruit produced in Spokane county, by no means the largest in eastern Washington from a horticultural standpoint, is placed at \$2,894,165, of which \$1,827,065 was received from the sale of apples.

This is looked upon as a remarkable showing when it is considered that only a few years ago not enough fruit was raised to supply the local markets.

The prune crop probably was the next in importance, and this was followed by strawberries and pears in the order named, while peaches, cherries, grapes and melons came as indicated. The grape crop fell short of expectations, because of the curtailed production in the Snake River and Clearwater districts, but the quality was of a grade to make up for any monetary losses.

That the apple is the chief orchard product of the Inland Empire as well as the national fruit is not questioned, and it is known also that those grown in Washington, Idaho and Oregon are in demand the world over; in fact, the highest market prices are paid in New York, Chicago, Boston, London, and cities in Australia for the big red-checked apples that grow so plentifully in this part of the country. Another thing that became manifest last season was that while the crops in the older apple belts in the middle west and eastern states were either failure or less than 20 per cent. of the usual production, the yield in the Spokane country was the largest and best from the standpoint of color, size and flavor in its history. Apple buyers from Chicago, New York and Boston commission houses, representing also exporters, were active in the district throughout the picking and packing season and high prices were the rule.

The shortage of labor and the lack of adequate transportation facilities during the harvest resulted in a waste, estimated to have cut down the total output by from \$2,500,000 to \$3,000,000 on apples alone.

England is the market of the world; it draws its supplies from all parts, and is the only nation that allows all products to enter her market duty free, thus securing for its people the best and largest variety of the world's products, one of the most conspicuous

and foremost of which is the far-famed "American apple," the qualities of which have procured for it a name and has doubtless been the origin of the saying, "An apple a day keeps the doctor away." It is known that the trade on this fruit has, from a small beginning, now acquired enormous dimensions, not only in the Inland Empire, but throughout the Pacific north-west, and the season just closed shows the healthy state it is in, and how rapidly it is increasing.

HEARD AT DINGEE & CONARD CO.'S.

Our Philadelphia representative called at the establishment of Dingee & Conard Co. a few days ago and found that this firm had added mushroom growing to their already large list of special subjects and with gratifying success. Mr. Lynch said:

"We are shipping now about 600 lbs. a week, and the crop has been on since November. Prices were low at first, but we are now averaging 60c. a pound, which is a very satisfactory figure when the crop is good.

"Cannas have always been a great specialty with us, and we may claim with all due modesty to have done our share in improving and popularizing them. Here is one called the 'Sweet Scented Canna'—botanically *Myrosma cannaefolia*. Flowers white, fragrant as an orange blossom.

"Another oddity you don't often see we have here is the 'seedless fig'—the genuine variety—in 4 in. pot plants with well developed fruits. This is a relic of the late talented but eccentric Patrick Meehan, who was in our employ at one time and left behind him many new roses and other things which he had developed by hybridizing and otherwise.

"No money in little palms at a quarter? Don't you believe it. We grow them from seed in six months and find them a very satisfactory item.

"Yes, *Oxalis Ortigiesii* is old, but still unexcelled as a window plant. We never have enough of it."

PERSONAL.

E. Jenkins, Lenox, Mass., has gone to England for a two months' vacation, during which time he intends visiting some of the old-fashioned gardens of England.

Visitors in Boston: Henry Wild, Greenwich, Conn.; H. A. Jahn, New Bedford; Wallace R. Pierson, Crowell, Conn.; H. S. DeForest of Pierson V-Bar Co., New York.

Chas. W. McCauley, secretary of the Florists' Club of Washington has been confined to his home for some days with a mild form of blood-poison as a result of a nail wound in his foot.

Secretary John Young of the N. Y. Florists' Club is about again after the serious injury to his wrist due to a fall on the icy sidewalk. It will be some weeks before he can use his injured arm.

Visitors in Chicago: Wm. Dykes, representing Ed. Jansen, New York; Wm. Desmond, representing L. S. Donaldson Co., Minneapolis, Minn.; Otto Will, Minneapolis, Minn.; S. Wertheimer, New York City.

NEWS OF THE CLUBS AND SOCIETIES.

GARDENERS' AND FLORISTS' CLUB OF BOSTON.

This club had a rousing meeting on Tuesday evening, February 25. The special attraction for the attendance of over two hundred members was a promised talk on Carnations by Wallace R. Pierson and an exhibition of carnations and other flowers from various sources in connection therewith. Mr. Pierson's address fully justified the advance interest and was pronounced one of the most intelligent and practical talks ever listened to by this or any other florists' club. The exhibition was also up to expectations and it was a late hour before the meeting dissolved.

After the usual routine proceedings, President Westwood addressed the club in optimistic strain, urging the cultivation of the closest fraternal relations between the members and aggressive loyalty to the organization during the year now entered upon, emphasizing the splendid possibilities of harmonious co-operation in the service of the club and, in grateful appreciation, thanked the various officers and committees of the past year for their earnest effort and well-done work. He appointed committees on exhibits and on refreshments for the present year, George M. Anderson being made chairman of the former and J. P. A. Guérineau of the latter.

Letters were read from F. R. Pierson, regretting his inability to visit the club on this occasion by reason of an accident which had incapacitated him for the present, and from President K. L. Butterfield of Amherst Agricultural College, extending an invitation to the members to visit the college in a body in August next. An invitation was received from the managers of the Market Flower Show to attend the exhibition on Saturday next. Announcement was made of the intention of the Executive Committee to arrange for a club banquet at an early date. Nine new members were added.

Mr. Pierson's lecture will be found on another page of this paper. At the close he was fairly bombarded with questions on various phases of carnation culture, all of which he answered with a convincing directness which showed him to be a master of his profession. Briefly, his replies were to the effect that in the treatment for red spider on carnations he had found soap one of the most efficient weapons and cuttings from infested plants dipped in soap solutions had been effectually cleaned. The same method with Bordeaux mixture 4-4-50 had freed cuttings from any infection of rust. He decried the disposition to take off cuttings before plants are ready for this, in the struggle for the "almighty dollar," and dwelt upon the essential qualifications of a good-substantiated, well-built flower, which are possible only under cool growth and rational treatment. Common sense, he asserted, was the best application for successful carnation growing. Deformed buds are frequently the result of unwise applications of sheep

manure, and pulverized cow manure, which will analyze to the value of \$2.50 per ton is an extravagant investment at \$20.00 a ton. He said that he uses more lime than all the fertilizers together and that among the most essential requisites for the production of fine flowers, he would place first, cleanliness—clean glass, clean atmosphere, clean benches and clean under the benches. His selection of six of the best carnations of the day would be, in order of preference, the following: Winsor, White Perfection, Beacon, Enchantress, White Enchantress and Rose Pink Enchantress. Vociferous applause and a standing vote of thanks was Mr. Pierson's reward.

President-elect M. A. Patten of the American Carnation Society, being called upon and received with enthusiasm, thanked the Club for his reception and asked for the support of the members for the meeting of that Society at Indianapolis next year, assuring them that they would find much there of interest and profit to them. Western soil and conditions are more favorable for the production of large and showy flowers but in keeping qualities the eastern grown flowers excel. Mr. Harrison, just arrived from England and intending to make his home in this country henceforth because of its brighter sunlight in winter, made a very interesting little speech on the comparative horticultural conditions as he had observed them.

Arranged with careful attention by the ever-ready Kenneth Finlayson, the exhibition platform presented a brilliant picture. Chairman Anderson of the judges made report of awards as follows: Awards of superior merit to A. N. Pierson for *Adiantum Farleyense*; to A. Roper for carnation Bay State, variegated. Superior mention to Wm. Nicholson & Son for carnation Afterglow. Honorable mention to F. H. Kramer for rose Queen Beatrice; E. B. Beals for white seedling carnations; H. W. Field for carnation President Seelye; J. D. Cockerott for carnation Harvard; John Barr for seedling carnation; Wanoka Greenhouses for carnations Wanoka and Climax; Peter Fisher for Ward seedling, Mrs. Tom Harvey; A. Roper for seedling carnation; H. A. Stevens, for seedling carnation; Joseph Fuller for double blue lobella; H. A. Jahn for carnation Lloyd and Jahn's Crimson; Wm. Downs for *Bougainvillea glabra*; Mrs. J. P. Snow for carnation Andrew Carnegie, scarlet sport from Harlowarden; E. A. Wood for scarlet seedling. The thanks of the club were extended to John M. Flood for carnation Beacon; J. N. May for Manda's seedling carnation; John Cook for rose My Maryland, certified at previous meeting; M. A. Patten for four vases of seedlings; A. N. Pierson for carnations Queen Louise and Winsor; Peter Fisher for carnations Beacon and Winsor; L. C. Mansfield for seedling carnation; Lively & Bond for seedling carnation; Duncan Finlayson for *Schizanthus Wisetonensis*; Wm. Downs for *Dendrochilum glutaceum*.

CHRYSANTHEMUM SOCIETY OF AMERICA.

The Chrysanthemum Society of America, realizing the necessity of closer relations with the various horticultural societies throughout the country, and agreeable to a vote taken at the annual meeting in New York City on November 6th, 1907, the executive committee cheerfully invites the hearty co-operation of every horticultural society in the United States, and offers the following for their careful consideration:

Any horticultural society, or gardeners' or florists' club may become affiliated with the Chrysanthemum Society of America on payment of an annual fee of twenty-five dollars, such fee entitling it to the following privileges.

1. The C. S. A. will offer a substantial silver trophy as a prize for chrysanthemums; the character of the class, and conditions of the competition to be left to the discretion of the society so affiliated.

2. To receive twelve copies of the C. S. A. publication, free of charge.

3. To have two free passes to the annual exhibition of the C. S. A.

4. To elect one of its members as a delegate to the annual meeting of the parent society, with voice and vote on any subject, except matters of finance, such delegate to be annually elected by the society affiliated.

Conditions of Affiliation.

Subject to the foregoing, the affiliated society shall pay the above mentioned fee on or before April 1st of each year to the secretary of the C. S. A. and furnish the following information:

(a) The full title of the society, the name and address of the secretary, and the name of the delegate elected.

(b) The date on which the next fall show will be held, and the conditions under which the C. S. A. trophy will be given.

(c) A copy of the prize schedule of the affiliated society to be sent to the secretary of the national society as soon as possible after publication.

DAVID FRASER, Sec'y.

AMERICAN ROSE SOCIETY.

A meeting of the Executive Committee is called for today, Thursday, Feb. 27, at 4 P. M., at the Hotel Martiniue, New York, by order of President Simpson, to take up the assignment of the numerous special premiums offered for the annual meeting and spring show to be held in conjunction with the Florists' Club of Chicago on March 25, 26, 27 in the beautiful Blackstone Hall of the Ar. Institute, corner of Adams street and Michigan avenue, Chicago, Ill.

There are now some thirty premiums besides the list printed in the official schedule, to be entered in a supplementary list.

The Chicago people are in dead earnest and we desire the active co-operation of each person east of the Allegheny Mountains to show what they can do.

BENJAMIN HAMMOND, Secretary

ILLINOIS STATE FLORISTS' ASSOCIATION.

The third annual convention of the Illinois State Florists' Association was held at Springfield on February 18 and 19 in the midst of the severest storm of the season. President A. C. Brown of the Springfield Florists' Club opened the meeting and introduced A. G. Murray, representing the Mayor, to whom Phil. J. Foley responded, reviewing the work already accomplished and urging co-operation to secure the opportunities that are before them. The address of President Albert T. Hey was rich in suggestions for broadening along present lines, and systematizing their efforts. As a committee on the National Flower Show he appointed F. L. Washburn, W. N. Rudd, W. L. Kroeschell; on State Fairs, J. F. Ammann, Geo. Asmus, A. T. Pyfer. Officers were elected as follows: A. T. Hey, president; J. F. Ammann, secretary; Geo. Asmus, vice-president; F. L. Washburn, treasurer. E. G. Hill was elected an honorary member. On Tuesday evening a banquet was tendered by the Springfield Florists' Club at the St. Nicholas which was enjoyed by about 125 guests. Hon. Chas. E. Hay acted as toastmaster. The trade exhibit filled Arion Hall, was well arranged and very comprehensive.

NEW ORLEANS HORTICULTURAL SOCIETY.

A meeting of the above society was held February 20. Owing to the illness of Secretary C. R. Panter, Paul Abele acted as secretary. Plans for the chrysanthemum exhibition were assigned to a special meeting, to be held on March 5. J. A. Newsham stated that he intends to leave for Central America in a few days, and he will pay special attention to orchids. Richard Eichling, grower for U. J. Virgin, exhibited fine Roman and Italian hyacinths, narcissi, lily of the valley, and callas. J. A. Newsham also showed extra large callas. Abele Bros. showed sweet peas, grown in the open.

CHAS. R. PANTER, Secy.

SOUTHAMPTON HORTICULTURAL SOCIETY.

A meeting of the society was held on February 20. President Clark in the chair. It was decided to hold a show some time in August on the grounds of the Art Gallery, as Mr. S. L. Parrish has generously offered them for this purpose and has donated a tent for use. The subject of the evening, "Planting of trees and shrubs" was very ably handled by treasurer J. King in an interesting paper. Discussion on tree pruning followed. At the meeting on March 5, "Vegetables and how to grow them" will be presented by J. Griffin.

U. G. AGER, Secy.

NEW YORK FLORISTS' CLUB.

L. C. Corbett, horticulturist of the U. S. Department of Agriculture, Washington, D. C., will read a paper at the meeting of the New York Florists' Club on March 9 subject, "Preparation of Soil for Greenhouse Purposes."

NATIONAL FLOWER SHOW COMMITTEE.

Chairman W. F. Kasting has instructed me to call a meeting of the National Flower Show Committee, to be held in Chicago, March 26, at 2.30 P. M. The place of the meeting will be announced later. This date is during the meeting and exhibition of the American Rose Society in Chicago. Very important business will come before the committee, and each of the chairmen of minor committees is expected to report. The presence of every member is earnestly requested.

J. H. BURDETT,

Secretary pro tem.

TWIN CITIES FLORISTS' AND GARDENERS' CLUB.

This club met at the Park Greenhouses, Minneapolis, February 18, with about seventy present. After inspecting the greenhouses and stock, a business meeting was held. The committee appointed to prepare a schedule of prices for bedding stock reported a minimum price for the various classes of plants, both-retail and wholesale; with a few changes this list was adopted. Plans for summer work and means for obtaining better accommodation at the State Fair were discussed, and a paper was read by A. S. Swanson.

CLUB AND SOCIETY NOTES.

The last meeting of the Detroit Florists' Club was called off owing to a heavy blizzard.

There will be a regular meeting of the Florists' Club of Washington on March 1st, when the election of officers will take place.

Pres. Kenyon L. Butterfield, Amherst, will address the Massachusetts Horticultural Society, Boston, March 7; subject, "Agricultural Education in the Public Schools."

The Spokane Floral Association, Spokane, Wash., at their meeting on February 11 took steps for the formation of an aster association, the membership fees to be used for cash prizes at the annual aster fair.

At the Rose and Carnation night of the Lenox Horticultural Society, Lenox, Mass., March 7, special premiums will be awarded by the society, and as carnations are grown quite extensively at Lenox competition for the various honors will be keen.

HORTICULTURE'S REPRESENTATIVES.

The following named gentlemen represent this paper in their various local districts, and are authorized to accept subscriptions, advertisements and news items:

BUFFALO, N. Y.—E. C. Brucker, 385-87 Elliott St.

CINCINNATI, OHIO—Frank W. Ball, 31 East 3rd St.

DETROIT, MICH.—Frank Danzer, 1487 15th St.

INDIANAPOLIS, IND.—George B. Wiegand 1610 N. Illinois St.

NEWPORT, R. I.—David McIntosh, Ledge Road.

MINNEAPOLIS, MINN.—C. N. Ruedinger, 2924 So. Aldrich Ave.

PHILADELPHIA, PA.—George C. Watson, Dobson bldg., 9th and Market Sts.

PITTSBURG, PA.—James Hutchinson, corner Duquesne and S. Negley Aves.

TOLEDO, OHIO—J. L. Schiller, 929 Prouty Ave.

COMMERCIAL CARNATIONS.

By Wallace R. Pierson, at Gardeners' and Florists' Club of Boston, Feb. 25, 1908.

I do not have any intention in writing this paper of giving history. That branch may be useful but it has been covered so many times that to go back to Lizzie McGowan and Mrs. Fisher is useless. We wish to consider just what working materials we have before us at the present time, and to learn how to make the most of what we have.

The carnation after the advent of Mrs. Lawson and the carnation before that time are as different in all essential characteristics as the light of a gray day in winter is to the brilliancy of the houses in full sunlight with the glare from the February snow. Day-break before Mrs. Lawson, as the sun breaking through the fog.

We have today a grand collection of varieties and there are so many new stars appearing and asking recognition that we are tempted to ask, where will it stop. "Because of the success of some new varieties, and because I have a good seedling, am I not justified in putting it on the market?" is the question we are so frequently asked. Let the owner of the seedling think of the number of horses bred from fast stock which are never entered. They are tried out, and if they haven't the ability to deliver the goods they are never entered in the race. So with the carnation seedling. Raise them if fancy leads you to do so. Try your hand at it, but know before they are presented to the public what their powers really are.

I believe that the qualities which go to produce a good seedling are, to a large extent, due to the inherent good qualities of the parents, but with the seedling there is apt to be an increase in vigor. The best articles and papers on the subject of seedlings can only be from those men who handle and study them most, and although a haphazard seedling may make good commercially, the best variety is more apt to be produced by one who understands the varieties he works on, and who makes his crosses with certain definite points in view.

The dissemination of a seedling being decided upon, the future success of it as a variety depends as much on the manner of producing and sending out the stock as on any inherent good qualities it may have, granted, of course, that it would never have passed the seedling stage had it not some of the inherent qualities which go to make up a Commercial Carnation.

What then is a Commercial Carnation? To be brief, it is one which the grower can handle so that it is a paying proposition for him, and this necessitates its being one which the public will buy with profit to the retailer. This definition is broad and yet it covers, I believe, the entire situation. It does not exclude the fancy sorts, providing they can meet the terms, which the public will buy and which is a paying proposition to the grower.

A very large bloom is not as a rule obtained in the same quantity from the same space as a smaller one. Here then seems to be the size limit. Can we secure enough more money for the individual bloom to warrant the growing of only such varieties as produce flowers larger than the ordinary? Per-

haps with some growers there would be such a demand but not as a rule would this be true. The Commercial Carnation in its broadest sense is the medium sized bloom, the average length stem, the non-bursting calyx, the even-colored bloom, with the keeping and shipping qualities which are usually a part of the make-up of such bloom as I have tried to describe. Light Pink, Intermediate Pink, Dark or Cerise Pink, Scarlet, Dark Red and White we must consider standards.

Variiegated we must class as fancy for both White and Yellow Variiegated are profitable only when grown where there is a market which calls for them.

The number of bloom per square foot of bench and the number of dollars per year is the only question the commercial grower should consider. The average number of bloom per plant is a deceiving method of calculating the profitableness of a variety, for one plant of some varieties will occupy the same space as three of a different type which run to bloom and not to plant.

Then too one year's experience with a novelty is not always a proper guide if the results be shown merely on paper. A different handling may produce different results. Very few varieties become disseminated without having some good features, and while one variety may do well in a locality, another may not. This is the nature of the beast, and having in mind several that have failed me, and done well elsewhere, I will drop the subject.

Given, then, a stock of standard varieties, what is the best method of handling them all the way through? To this I reply, with consideration for the individuality of each and every variety in your list. I will try to explain myself on this subject.

Three distinct classes of varieties appear to me. One inclined to soft, heavy foliage and curly leaves. This type is inclined to come short jointed, and to require an unusually heavy body of roots to produce early bloom with stems long enough to be worth the handling. For these there is nothing but indoor culture to secure the best results.

The second class is the doubtful one. The thin foliaged, loose jointed specimen which makes only bloom if grown inside and very little plant. It needs less soil, and with less top makes correspondingly less root. Field culture with early benching seems the best, as the production of plant is easier to accomplish in the field.

As a type of the third or variable class, I wish to mention Enchantress, a variety which will be found superb for indoor culture, and an easy variety to lift from the field, even as late as September to fill the last ends and prevent loss of space.

Classing these varieties then, as we do, we plan our planting as soon as we can determine how much room we can count on after Easter. The condition of the breaks from ten to twelve inches above the soil in February will determine this. Get the heavy foliaged varieties ready for an early start. Then comes the wait for after Memorial Day, and the summer's shifting is in full blast, aiming always to leave a part of a house of White and some Enchantress for the last of June.

We like to handle young stock in

pots for the April benching, and in 3-inch is a convenient size to handle, this stock having been shifted from 2-inch, or 2 1-4, as the case may be. Where this stock has been in 2-inch, however, a shift to 2 1-2 inch and then to 3-inch is to be preferred to a single repotting.

For later use, benching out in shallow soil about 4 inches apart gives a better chance for the plants, and means less work, and danger of loss or stunting due to being pot bound is avoided.

Field planting from 2-inch pots is the next in order, and then the care in the field. Summer watering I do not approve of, and for the following reasons: It is very seldom that the soil takes up this moisture to any depth. If done at night, the sun of the next day takes more even than was given. A continual wetting of the foliage at night is a great incentive to leaf spot, and a growth under these conditions will be soft and is therefore an easy subject to such fungus.

The best plants come from the field that gets the most hoeing, and I do not think a well cultivated field can be improved upon, except by more hoeing.

Our system then is a combination of the two, or rather three methods: Pot culture, bedding them out in the houses intended for chrysanthemums, and field culture.

"Would you plant them all inside if you could?" is a question I am often asked, and I can only answer it by saying that it is an impossibility to handle all our stock with any one method. Our supply of bloom is broken for only two months, as we cut by September first from the first planted houses, and our last houses we aim to plant in early July and do not care to cut from them until November.

Last season we planted one bench in March, and they are still looking well and producing the bloom.

"Do you prefer the bench to the solid bed?" is another. I will answer it by saying that for early planted stock the bed is superior; for field plants I prefer the bench. The heavy foliaged varieties seem to be in their element on the beds, while the others seem to even up matters.

Temperatures can almost be figured by classes, the heavy foliaged varieties, as a rule, standing for a little more heat. The evenness of the night temperature is perhaps the most essential. Very seldom have we had any trouble with bloom which could not be traced to this source. Softness in such varieties as Enchantress usually means an overabundance of water at the root, or a too high temperature at night. A hard bud is usually a check from contact with glass, or cold draughts of air at some time, due perhaps to a sudden drop in temperature, or a broken glass. If we would grow carnations well we must watch their nights.

The producing of the best is on-long struggle. Insects, fungi and temperature all make it a never ending fight. Watchfulness, combined with common sense and the willingness to do hard work, will succeed in meeting these troubles, and coming out with success and credit.

To the retailer I would say, "Help the grower." What sells best with you? What colors are you wanting

most? Advise him how they keep, and he'll know how to run the houses.

And growers, let me say to you that it is poor economy to grow second-class stock because business is dull this season. On good stock depends your future, for it is one of the essential elements of success.

POINTS ON CARNATION BREEDING IN AMERICA.

Read before the joint meeting of the American Carnation Society and American Breeders' Association by C. Willis Ward, Queens, N. Y.

(Continued from page 242)

Color Percentage in Various Pedigree Crosses.

In order to render the study of pedigrees easier, I have devised a system of "bench-cards" which are used as labels tied to each variety under experiment, and which at the end of the season are filed away in a card index, thus preserving all of the original records made in my work. I find this system exceptionally useful, as it enables one to determine at a glance the pedigree of any variety when working upon it. My object has been to study out some system whereby the color tones might be purified, and rendered more brilliant or delicate and more pleasing to the eye; and while I have paid some considerable attention to size of flowers, freedom of bloom, integrity of calyx, length and strength of stem, and fragrance, the purity of the color has been my first consideration. In order to develop more brilliant shades, I have, as a rule, confined my crosses to plants both bearing flowers of the color which I desire to improve that is to say, crimson were crossed with crimson, light pinks with light pinks, dark pinks with dark pinks, whites with whites, and so on; and the result seems to indicate the following hypothesis, viz., that the percentage of color contained in the percentage for several generations back controls to a very large extent the color of the progeny. I do not, of course, mean that by using parents on both sides that have practically a scarlet pedigree for several generations back all scarlets will be invariably produced, but that where such parents are used, the chance of securing the improved scarlet color desired are greatly increased. True, the progeny of such parentage frequently show many shades varying from the red or scarlet, such as pinks, maroons, purples, and even white and yellow grounds with more or less variegation of all of the colors mentioned. Again, a cross between a white variety, having practically a white pedigree for several generations, frequently pro-

duces scarlet flowers, but, as a rule, such scarlets are not as brilliant or persistent as those produced from plants having mainly scarlet pedigrees. One of the best ways of providing this hypothesis is to take two scarlet parents the pedigrees of which are mainly white. By crossing these, very few scarlets will be produced—sometimes none at all—but a large percentage of the progeny will frequently be pure white, or white grounds marked with scarlet or various shades of pink. I have sometimes thought that by taking a scarlet variety of comparatively pure scarlet pedigree and crossing it with a white variety of the pedigree of which is largely scarlet, more clear and persistent scarlet tones are produced than where the pure scarlet pedigrees are used. For I have often found that with pure scarlet pedigrees there is a tendency for the color, even though it be very brilliant, to blacken, or turn a slaty shade when exposed to bright sunshine.

Working for Early Blooming Character.

While I have not been able to prove to my satisfaction that this hypothesis is right, there still seems to be evidence enough to warrant the assertion that if you desire free-blooming habits use parents having early free-blooming pedigrees. The same should hold good if you desire to produce varieties with extra large blooms, or perfect calyx, or any other peculiarity in habit or form of flower; it also seems to hold good in regard to fragrance. Again, the early-blooming varieties usually have small to medium-sized blooms, and the very large flowering varieties are generally late and inclined to be shy bloomers. This can to some extent be overcome by crossing large-flowering late-blooming varieties with the early free-blooming ones which have the largest blossoms. This, if followed up, will in the end produce large-flowered early-blooming varieties. Working on these lines, I have already succeeded in producing "Alma Ward," which under our intensive culture gives flowers ranging from 2.1-2 to a little over 4 inches in diameter on stems from 2 to 3 feet in length, according to the season; and those flowers are produced in sufficient abundance to make the variety very profitable commercially. It is also a fairly early bloomer, coming into flower by October 1. This variety was obtained by crossing "Prosperity," a large-flowered, not very free variety, with a white seedling having a very large flower and long stem, and quite a free bloomer.

Mr. Peter Fisher, the raiser of "The Lawson" and "Enchantress," two of the most satisfactory of our American commercial varieties, secured his strain from crosses between "Daybreak" and a sport of "Tidal Wave," two quite large-flowered very free-blooming as well as early varieties. In "The Lawson" a curious blend-

ing of the qualities of both parents may be observed. "Daybreak" is a long-stemmed variety; "Tidal Wave" usually has quite short stems in the early part of the season, but as the season advances they become as long as those of the present "Daybreak." Double flowers may be produced by crossing single blooms with pollen from very double ones, and the more double the pollen parent is, the greater seems to be the proportion of double-flowering seedlings produced.

Influence of Ancestry.

Studies of color characteristics during the past twelve years seem to have determined that the male parent does not exercise any paramount or dominant influence—but that either male or female or both may determine the dominant characteristics of the progeny.

In the case of seedlings used from other hybridizers, I am not able to give the color parentage, but expect if we had such color parentage it would not tend to change the results. My conclusions from these studies have led me to believe that it is not either parent that exercises dominant influence upon the hybrid, but there may be several elements which tend to control the characteristics in the hybrid. As for instance, the total percentage of the characteristics of a number of ancestors which may be illustrated as follows: Supposing that crossing a dark pink upon a white, sixty per cent. of the ancestry on both sides was dark pink, the chances to secure a dark pink to the hybrid would be largely in proportion to the percentage of dark pink existing in the ancestry on both sides. On the other hand, supposing that we crossed a white with a white which had a large percentage of dark pink in the ancestry, and, as a result of said cross, we produced a large percentage of whites. This might tend to show that the condition of the chromosomes in the cells exercised the paramount influence in determining the characteristics produced in the hybrid. Now, it might be possible to take different individuals, the result of the same cross, all of the individuals being white, the crossing two individuals might produce a large percentage of whites, while crossing two other individuals, all being white, might produce a large percentage of pink. This would again tend to prove the theory that the condition of the chromosomes in the cells of the individuals might exercise paramount influence.

There is another peculiar thing that seems to be the case in regard to crosses between the same individuals, and that is that crosses between such individuals made at different periods of the year when the plants were growing under somewhat changed conditions produce different results. This might lead us to the theory that the condition of the individuals at the time that impregnation takes place may exercise paramount influence over the characteristics of the progeny. This theory might seem to be proven by the results obtained in the production of mankind where a dozen children the result of the union of two individuals and born at somewhat widely different periods present widely different char-

acteristics, both mental and physical as well as in appearance.

My impression is that it will take several years' study in order to determine the question. Possibly it may be necessary in continuing my experiments to segregate the female blooms in apartments by themselves so as to prevent the chance of a foreign grain of pollen alighting on the pistil, as this might explain some of the apparent idiosyncracies in the results obtained in my youth.

A Summary of Results.

The summary of the results of crossing different colors may prove very interesting. For instance, where crimson was crossed with crimson the results produced twelve crimson and five scarlets; where dark pink was crossed with dark pink, thirty-seven dark pinks were produced; where white was crossed with white, thirty-four whites were produced, and only one white variegated with pink, there being no solid colors. Where white was crossed with crimson, five whites were produced and two scarlets, the balance being divided between dark pink, flesh pink and crimson, but where white was crossed with dark pink, the result was three pure whites.

There is another element in making up these studies which may interfere with their value in deciding the question of paramount influence and that is that only varieties that possessed a number of characteristics were preserved and records kept of them. There is a great mass of stuff that was thrown away, and in making these crosses we were constantly selecting plants possessing all the characteristics desired. I am inclined to think that the fact that we threw away a lot of useless stuff will not change the result. For instance, taking the result of crossing white with white, there were saved for observation from these crosses thirty-four whites and one white variegated with pink, as all the white parents of both sides were selected not only for their good color, but also for size and form of flower, integrity of calyx, healthy constitution, stiffness of stem, vigor of growth, and also for freedom of bloom. The fact that thirty-four whites were selected for trial as against only one white variegated with pink and that the results of these white crosses did not produce anything in solid colors that were worthy of selection for trial would seem to indicate that whatever laws exist in regard to the influence of the parents upon the progeny would finally prove to be applicable not only to color but to all other characteristics.

Some Interesting Conclusions.

Now, when we come to the consideration of pure crosses which we might specify as crosses between males and females of the same color, we find the following remarkable results: a cross of white upon white produced thirty-four whites against one other color; a cross of light pink upon dark pink produced six light pinks as against four of other colors; a large number of crosses of dark pink upon dark pink produced thirty-seven dark pinks as against twenty-four of other colors; a cross of scarlet upon scarlet produced ten scarlets. All of which would tend

FORMOSA

LILIUM LONGIFLORUM

Ask your dealer for our own special grown stock or write us direct for quotations. Only a limited quantity available for the coming season 1908. Delivery will be made the first part of August. The bulbs are thoroughly ripened one month before the Bermuda Harrisii and are considered far superior in quality as they are *entirely free from disease*.

Careful trials were made for two years and were so successful that we imported over 300 cases last season. Our cases will be marked Y. N. Co.

YOKOHAMA NURSERY CO., Ltd., 31 Barclay Street, NEW YORK

to indicate that by using two individuals possessing the same characteristics, the chances to reproduce a large proportion of these same characteristics are very much enhanced. This might be shown very nicely in the cross of crimson upon scarlet, which produced twelve crimsons and five scarlets as against three of other colors. In this case it is probable that there was considerable crimson blood in the ancestry of the female parent.

The cross of crimson on crimson need not be taken very seriously, as it is the result of but a very small number of seeds, and I am inclined to think that there was considerable scarlet blood in either one or both of the crimson parents.

Of course when we make mosaic crosses, such as white upon scarlet, pink, crimson and other colors, we must expect a breaking up of colors in the progeny, and where we cross two of the same color we must expect more or less breaking up of colors in the progeny, especially where the immediate ancestry contains parents of widely varying colors.

Referring to examples of individual crosses, suppose we take cross 2313-07, a scarlet upon white. It will be noted that in these notes the pollen parent is mentioned first, as some other hybridizers mention the female parent first. Now, the color parentage running back for some ten or twelve years shows that on the male side there were six dark pink, six yellow variegated, five crimsons, three whites, two scarlets, one light pink and one white variegated. This pedigree is

made up without reference to the nearness of any of the individuals of any particular color being particularly near to the seed and pollen parents, but it simply indicates that among the male parentage of both sides six dark pinks occur, etc., while on the female side five dark pinks, three crimsons, one scarlet, four whites, five white variegated and two whiteflaked occur.

Assuming that dark pink and crimson, purple and scarlet would tend to produce dark pink or scarlet—we would naturally anticipate a large number of dark pinks or scarlets—whereas we get only one dark pink, one scarlet and one white, thus indicating that other influences than the percentage of the same characteristics in either or both of the ancestors may determine the characteristics in the hybrid.

The results of these experiments and the study thereof has led to the conclusion that neither parent exerts predominant influence in determining the characteristics of the progeny—but that said characteristics may be determined from either side of the parentage or may result from modified characteristics of both parents as well as both ancestry.

MOVEMENTS OF GARDENERS.

John Erickson has been appointed gardener for Mrs. C. C. Converse and Mrs. Lester Leland, Malden, Mass.

James Sage has succeeded Alexander Adam as superintendent for Alfred G. Vanderbilt at Oakland Farm, Newport, R. I.

Harry C. Hogan is now in charge of the gardening department of Sandy Point Farm, Newport, R. I., the residence of Reginald Vanderbilt.

David F. Roy, Malden, Mass., assumes his new position in charge of "The Moorings," Col. H. E. Converse's estate, at Marion, Mass., on March 1.

George Cray has been appointed superintendent at Pine Banks Park, Malden, Mass. His previous duties as foreman well qualify him for the position.

Harold Edgar has taken a position with E. D. Kaulback & Son, Malden, Mass., and David Stark, who had charge of the fruit department at the Converse estate, has gone to the Hooper estate, Manchester, Mass.

SHAMROCKS IRISH: THE REAL THING, GREEN

Very Fine and Strong Plants ready now for delivery. Perfect Beauties, per 100, \$4.50; per 1,000, \$45.00. 50 cts. per dozen, postpaid. Extras added.

THE HOME OF
PRIMROSES

JOHN F. RUPP, Shiremanstown, Pa.

Seed Trade

It was supposed that the place for the next Cannery Convention had been decided upon at Cincinnati, but information which comes to hand during the past week indicates that this matter is still unsettled, and that some other place may be chosen. Interviews with prominent canners show that they are of the opinion that Chicago is to be the place, but it seems that the Machinery & Supply Men's Association have something to say in the matter, and according to reports, the Chicago proposition is not wholly acceptable to them. Just when this matter will be definitely settled cannot be stated now, but something will have to be done in the near future.

Ignorance of seeds and plants even by many of our most intelligent men is proverbial. A case in point is from an item in Harper's Magazine, by Wm. Dean Howells. It is best to quote his own words, which are as follows:—

"We know of a case, no longer ago than last summer, in which the gardener bought a seedman's last dozen of eggplants, which he duly set out in his plot, and which flourished with uncommon promise up to the blossoming moment, all looking alike and unmistakably eggplants. But at this point they differentiated themselves; five continued eggplants, and seven turned aside and became petunias. They came, indeed, very beautiful petunias, delicious in fragrance, rare in form, and most delicate and novel in color; but, after all, they were not eggplants. The seedman of whom they were all bought, being oppositely reproached, justly remarked that the gardener who supplied them must have got them mixed. Sometimes, this sort of mixture begins further back, with the very seeds themselves." Comment in such a case as this seems to be quite unnecessary.

There is very little activity just at the present time in seed corn or seed peas, most of the large buyers generally having secured their stocks for the coming season's planting. There is, however, quite a probability that the slender reserves of seed corn will be heavily drawn upon for replanting purposes. Much of the seed that will be planted this year will be of such poor germination that unless the weather, the soil and all conditions are most favorable, replanting on an extensive scale will be necessary and, before the 1st of July, it is probable that seed corn of good vitality will be again at a premium.

C. W. Witbeck has opened a seed store at Schenectady, N. Y. Whether he is to succeed his brother, Clark Witbeck, or whether the latter will still continue is not positively known, but the information to hand indicates that Mr. Clark Witbeck has retired from the seed business, to devote his time to hardware affairs. Mr. C. W. Witbeck has had many years' experience, and he will, no doubt, have the best wishes of his many friends in his new venture.

The troubles between two of the

very prominent seed firms of the country, which threatened serious results in the early part of the season, it is learned, have been amicably adjusted. The gentlemen interested deserve the thanks of the trade for reaching the agreement they have, and it is to be hoped that any future misunderstandings between members of the seed trade will be as peacefully adjusted.

Most of the growers of peas and beans are said to be now booked to their limit of safety on most varieties of peas, at least, particularly of the canning varieties, and now, if Mother Nature will give us a favorable season for the raising of our crops, the canners will be made happy by full or nearly full deliveries of their orders.

President Green and Secretary Kendel of the American Seed Trade Association met on Saturday in Detroit and made final arrangements with the Hotel Pontchartrain for headquarters for the twenty-sixth annual convention of the Association next June. The use of a suite of rooms on the parlor floor was secured for the meetings and accommodations for all were assured at reasonable rates.

A. T. Boddington has taken the entire floor over his present quarters in West 14th street, New York. The offices will be located on the new floor and much-needed expansion secured. The new cosmos Lady Lenox, which Mr. Boddington is introducing this season, is enjoying a large sale.

Visitors in New York: Chas. P. Braslan, of Braslan Seed Growers' Co., and L. W. Wheeler, formerly manager of Vaughan's Seed Store in New York, of San Jose, Cal.

CATALOGUES RECEIVED.

William Pfitzer, Stuttgart.—Catalogue of seeds and plants with novelty list for 1968.

W. Atlee Burpee & Co., Philadelphia, Pa.—Prize supplement to catalogue for 1968. This gives full particulars of the distribution of cash prizes among planters of Burpee's seeds during the past season.

A catalogue of plants, seeds, bulbs and horticultural requisites, in the English and Japanese languages, the first of its kind ever printed, is being sent out by the Yokohama Nursery Company; 20,000 copies have been circulated in Japan and China for local trade, the English language being much more generally understood in China than is the Japanese. The book is well filled with half-tone illustrations. We notice in the lists quite a number of American plants, including a comprehensive list of the best American peaches and the pumping and spraying apparatus of the Deeming Company, Salem, Ohio, whose manufacturers are well thought of in that distant land.

\$250,000 FOR GYPSY MOTH FIGHT.

The House Committee on Agriculture has voted to increase the appropriation to fight gypsy and browntail moths in New England from \$150,000 to \$250,000.

Quality the First Requisite

FOR OVER SIXTY YEARS WE HAVE SUPPLIED THE PRIVATE AND COMMERCIAL GROWERS

Giant Cyclamen, best strain and colors, 100 seeds \$1.00, 1000 seeds \$9.00
Asparagus Plumosus Nanus, 100 seeds 75c, 1000 seeds \$5.00.
Asparagus Sprengerii, 1000 seeds 75c.
Cosmos, early White and Pink, 20c trade pkt., \$1.00 oz.
Tuberose Excelsior Pearl, \$1.00 per 100, \$8.50 per 1000.
Begonia, single tuberous rooted, in colors, \$3.00 per 100
Gloxinia, Red, White, Blue and Spotted, \$4.50 per 100.
Scotch Root, Bamboo Canes, etc., etc. Send for catalogue. Wholesale list to trade only.

SCHLEGEL & FOTTLER CO.
26-27 So. Market St., Boston, Mass.

MICHELL'S

SEEDS

Are Always Reliable.

1018 MARKET ST.
PHILA.

WHOLESALE CATALOGUE FREE

GLADIOLI

I can satisfactorily supply your wants for Gladioli for forcing or outdoor planting. Mixtures, color sections or named varieties of exceptional beauty.

Write for Prices

ARTHUR COWEE

Gladiolus Specialist

Meadowvale Farm, BERLIN, N. Y.

HYACINTHS, TULIPS, NARCISSI AND OTHER BULBS

ROMAN HYACINTHS and the true PAPER WHITE GRANDIFLORA

Ask for our Wholesale Trade List at Hillegom

K. VELTHUYS, Hillegom, Holland
Rep. by FELIX BOSCH, 260 Clarence St., Easton.

The latter item is now included in the agricultural appropriation bill. The result was largely due to the efforts of Representative Weeks, who has worked earnestly to secure a larger appropriation.

A combination was formed with Southern members who are interested in exterminating the Texas cattle tick. The appropriation for the tick was also increased from \$150,000 to \$250,000.

LIST OF PATENTS.

Issued February 11, 1908.

- 878,561. Wheel Hoe. Marcellus Ramsey, North Girard, Pa.
- 878,565. Double Plow. William L. Selman, Summerville, Ga.
- 878,715. Hand Plow. Charles S. Ergenbright, Caney, Kans.
- 878,774. Plow. Charles R. Coffman, Bridgewater, Va., assignor to D. Saylor Thomas Bridgewater, Va.
- 878,920. Hoe. Benjamin R. Williams, English, Ark.
- 879,020. Plow. Patrick Sweeney, Ericson, Nebr.
- 879,037. Riding Attachment for Plows, Harrows and the Like. Harry P. Courtright, Hoiland, Mo.
- 879,047. Adjustable Supporting Stick for Plants. Henry Heubner and Adam Heubner, Brooklyn, N. Y.

ASTER SEED

**Why not plant the BEST?
We have varieties that are worth the money
We have a \$250.00 prize competition
Our ASTER BOOK is free--it explains**

**ALTIMO CULTURE CO.
CANFIELD, - - - - OHIO**

TOBACCO STEMS FOR FUMIGATING

Black Kind, \$1.50 100 pounds

W. ELLIOTT & SONS
201 Fulton St. New York

ESTABLISHED 1802



Send for our Wholesale Catalogue
of Seeds for Florists and Market
Gardeners, ready in a few days.

	Per doz.	Per 100
GLADIOLUS PRIMULINUS	\$8.00	\$60.00
PRIMULINUS HYBRIDS	3.00	20.00

J. M. THORBURN & CO.
33 Barclay St., through to 38 Park Place
NEW YORK

Everything of the Highest Grade

BRIDGEMAN'S SEED WAREHOUSE
RICKARDS BROS.
Props.

37 East 19th St., - NEW YORK CITY

BRASLAN SEED GROWERS CO.
GROWERS FOR THE
WHOLESALE TRADE ONLY
SAN JOSE, - - CALIFORNIA

Burpee's Seeds
PHILADELPHIA

Blue List of Wholesale Prices mailed
only to those who plant for profit.

**CAULIFLOWER^S
CABBAGE^E**
HJALMAR HARTMANN & CO.,
12 Stormgade,
COPENHAGEN, DENMARK.

BAMBOO CANES **TOUGH AND STRONG**
6 ft. long — \$1 per 100; \$6
per 1000; \$11 per 2000

They cost about 10 per cent. more than
other kinds, and they are 10 times better.
STUMPP & WALTER CO., - 50 Barclay St., New York

RELIABLE SEEDS—SOW NOW

	Tr.	6 Tr.
Alyssum Carpet Queen, real dwarf for pots only, no equal....	\$0.25	\$1.25
Begonia Gracilis Luminosa, new	0.50	2.50
Ertordia, beautiful pink...	0.50	2.50
Lobelia, new Trailing Hamburgia	0.30	1.50
Petunia, Double Fringed Giants...	1.00	5.00
Single Fringed Giants...	0.75	4.00
Phlox, best for pots, Fireball, Roseball, Snowball, each color.....	0.25	1.25
Primula Obconica Grandiflora, new Hybrids as: Blood-red, Blue, Carmine, Pink, Purple, Violet, Pure-white, Compacta, Gigantea, Fringed Mixed Hybrids, each separate....	0.50	2.50

My New Price List will guide you through reliable seeds. Ask for same

O. V. ZANZEN
Seedsman. HOBOKEN, N. J.

Best Quality Fall Bulbs

It is to your advantage to place your order early. Send us a list of your wants and we will quote you rock-bottom prices. Copy of our Florists' Bulb Catalogue will be sent upon request. Catalogues now ready.

VICK'S SUPERB PANSY SEED

All the best varieties in separate colors

VICK'S SUPERB MIXTURE

the best strain from all the leading named sorts
1-8 oz. 75c. 1-4 oz. \$1.50 Ounce \$5.00

JAMES VICK'S SONS, Rochester, N. Y.

CYCLAMEN Farquhar's Giant Strain

Unsurpassed for size of flowers.

Giant Crimson Giant Pink
Giant White Finest Mixed
Giant Excelsior, White with
Claret Base

100 seeds, \$1 25; 1000 seeds, \$10.00.

R. & J. FARQUHAR & CO.
6 & 7 So. Market St., Boston, Mass.

BRECK'S SEEDS
For Farmer, Market Gardener and Florist
New Crop High Grade
Catalogues mailed free on application

Joseph Breck & Sons Corp.
47-54 NO. MARKET ST., BOSTON, MASS.

WIBOLTT'S SNOWBALL CAULIFLOWER-SEED
is the earliest of all Snowballs, the most compact, the surest header, is giving the largest and snow-whitest heads, and is the best keeper in dry-weather. Demand it through your seed-firm or direct from
R. WIBOLTT, NAKSBOV, DENMARK

No. 34



Cyclamen

Superb English Strain
Second to none in size
of flowers
Giant Crimson.
" Pink
" White,
" White with
Claret base.
" Mauve.
" Salmon Queen.
" New Fringed.

100 seeds \$1; 1000 seeds \$9.

H. E. FISKE SEED CO.
12 and 13 Fanuell Hall Square, BOSTON MASS.

JUST ARRIVED
LARGE SHIPMENT OF
High-Grade SCOTCH SOOT.

We have the Stott Double Nozzle
THOMAS J. GREY CO.
32 & 33 So. Market St., BOSTON

C. C. MORSE & CO.
Address all communications to our permanent address
48 to 56 Jackson St., San Francisco, Cal.
**The Largest Seed Growers
in the United States**

GLORIOUS AMERICA

STRONG BULBS FOR FORCING, \$60 per 1000

PHOENIX ROEBELINI

The Jewel of all the Palms. \$4 per 100 for seedlings, \$7 per 100 in 2 inch pots.

Complete Trade List of Florists' Forcing Gladioli, Lilies, Irises, NOW READY. 8 per cent. discount for cash with order.

JOHN LEWIS CHILDS
FLORAL PARK, NEW YORK

Martial Bremond

WHOLESALE GROWER OF FRENCH BULBS

— OLLIOULES, FRANCE —

A superior quality supplied at market prices. Shipments made direct. Cases marked to order.

Sole Agents

RALPH M. WARD & COMPANY
12 West Broadway - - NEW YORK

GREENHOUSE-GROWN VEGETABLES.



The taste for greenhouse vegetables is due not alone to the fact that many kinds may be had out of season, but

more particularly, we think, to their more delicate flavor and greater tenderness than the out-of-door products. We know of persons who having partaken freely of greenhouse cauliflower and string beans during the winter and spring months, have actually acquired a distaste for these from the summer garden, and do not eat them.

Not a few private estates in various parts of the country now have elaborate vegetable forcing houses—the Spaulding Estate at Prides, Mass., is perhaps the most extensive in New England. Here the gardener, Mr. F. E. Cole, turns out from November until July a continuous supply of nearly all vegetables seen in the summer garden. Cauliflower grown in pots or on benches is supplied from November to June, as are also beets, beans, tomatoes, cucumbers, spinach and a large variety of salad plants. Among other greenhouse vegetables forced by Mr. Cole are asparagus, corn, melons, squash, rhubarb, sea-kale, etc. Mr. Cole is an expert on mushroom culture, a section of one of his benches being reproduced in the accompanying illustration. The crop here grown is from the pure culture spawn, which gives a large solid mushroom particularly suitable for broiling, but perhaps somewhat coarser in texture and less highly flavored than the smaller "buttons" produced from the imported mill-track spawn.

SHAMROCKS

The popular miniature plants in

1 inch pots per 100 \$4 00
2½ inch pots " " 4.00

The "ALL GREEN" Variety.

Green Carnation Coloring

FOR ST. PATRICK'S DAY.

Put up in sealed cans—pts. 65c; qts. \$1

Green 6-ply Florists' Twine

Matching exactly in Color the FLORISTS' GREEN FOLDING BOXES. Constantly on hand.

On 16-oz. tubes only; 60c. per lb.

N. F. McCarthy & Co.

84 Hawley St., Boston, Mass.

COMPLETE LINE OF

Hardy Trees, Shrubs, Vines, Evergreens and Perennials

Order now for early delivery. Send for illustrated catalogues

EASTERN NURSERIES, M. M. DAWSON, Mgr.
Jamaica Plain, Mass.

Single Chrysanthemums

ARE THE CRAZE

for the time being.

Are you in line to meet the demand?

I have now ready

KATIE COVELL, ROB ROY,
HELEN TOTTY, HAROLD
BISHOP, MRS. UNTER-
MEYER, ANNA
SPANGLE,

and others, at

\$2.00 per doz., \$15.00 per 100.

I also carry a full line of novelties and standard varieties of

Chrysanthemums, Carnations and Roses

CHAS. H. TOTTY, MADISON, N. J.

Attention Gardeners

WE ARE NOW DELIVERING

Novelty Chrysanthemums

THOSE FIRST PROPAGATED,
STRONG PLANTS THAT BRING RESULTS

NOW READY: All our Novelties (except Golden Glow); all the English '08 (except W. M. Moir); all the French '08.

Best Plants Ever in Stock

We are offering all the Standard Varieties both Commercial and Exhibition.

ELMER D. SMITH & CO.,

Successors to Nathan Smith & Son

ADRIAN, - - - MICH.

New Violet BOSTON

In introducing this new variety to the trade I wish to state that I have been growing it in quantity for the past two years and do not hesitate to state that it is entirely distinct, a strong grower, a free bloomer, and the finest single violet in cultivation. Ready for distribution in April and May. Orders booked now. \$2 per 12; \$12 per 100; \$100 per 1000. 500 at 1000 rate.

WILLIAM SIM, CLIFTONDALE, MASS.

You will find something worth reading on every page of HORTICULTURE.

LILIUM AURATUM

9-11 \$75 per 1000

ROSEUM and RUBRUM

9-11 \$65 per 1000

MULTIFLORUM

7-9 \$45 per 1000

O. RUSCONI 128 West 6th St. CINCINNATI, OHIO

DREER SPECIALS



Golden Yellow Calla Elliottiana We have a fine lot of bulbs of this beautiful variety which if started into growth now can still be flowered for Easter. This Golden Calla is still but little known and always attracts attention. \$2.00 per doz., \$15.00 per 100.

Fancy Leaved Caladiums We are this season offering the finest set of Standard Fancy Leaved Caladiums that has yet been sent out at popular prices, 25 distinct sorts. \$1.50 per doz., \$10.00 per 100; the set of 25 varieties for \$3.00.

New Fancy Leaved Caladiums A set of twelve wonderfully marked beautiful varieties. The set of 12 sorts for \$2.50, or \$20 per 100.

Canna King Humbert The best of the dark leaved, very large flowered brilliant scarlets and a perfect gem that pleases everyone. We are long on this and offer at the special price of \$1.25 per doz., \$8 per 100.

Canna Grand Chancellor Bulow A remarkably rich crimson scarlet that never sunburns, with flowers of good size and very free, was much admired in our trial grounds during the past two seasons. \$1.50 per doz., \$10 per 100.

Canna Frau Marie Nagel An introduction of Wilhelm Pfizers, the Canna specialist of Germany who has given us many important varieties. It is the most floriferous of the large creamy white sorts and contrasts fine with high-colored sorts. \$1.25 per doz., \$8 per 100.

New Decorative Dahlia Souvenir de Gustave Doazon The most sensational Dahlia of the season, of mammoth size, producing under ordinary cultivation flowers 6 inches in diameter and can be grown to measure full nine inches, it is of free growth and remarkably free flowering. Certain to become one of the most popular sorts for cutting and decorating, its pure scarlet color, immense size and unique form guarantee its future.

Rex Begonias We have at the present time the finest lot of Rex Begonias that we have been able to offer for many years, twenty distinct varieties, fine plants in 3 inch pots, \$1.25 per doz., \$8 per 100; the set of twenty sorts, one of each, for \$2.

HENRY A. DREER, 714 Chestnut St., PHILADELPHIA, PA.

BEGONIA GLOIRE DE LORRAINE

Stock plants to propagate from, or for growing on, 2½ inch and 3 inch pots, \$15.00 per 100; \$140.00 per 1000.

These are now ready for delivery.

Adiantum Farleyense

strong stock plants from 6 inch pots, good for propagating only, will average 50 eyes each.

\$6.00 per dozen.

J. A. PETERSON

McHenry Ave., Westwood, Cincinnati, Ohio.

GLADIOLUS BULBS

100,000, from 1½ inches up to \$1.00 per 1000
100,000, ¾ to 1¼ inches @ \$2.00 per 1000
Cash with order. Description given on request.
Nice block of California Privet, \$10.00 per 1000 and up, as to quality. Write for particulars.
Nice lot of American Chestnut Trees at a bargain. Thirty-five large Sugar trees, most of them sample trees.

I. & J. L. LEONARD, IONA, N. J.

ORCHIDS

The largest importation of Orchids ever received in this country WILL ARRIVE next spring from Brazil, Colombia and Venezuela. If you intend putting in stock wait for these to arrive and we will quote the Lowest Prices in America.

ORDONEZ BROS., - Madison, N. J.

ORCHIDS

Largest Importers, Exporters, Growers and Hybridists in the World
Sander, St. Albans, England and 235 Broadway, Room 1 NEW YORK CITY

... ORCHIDS ...

Just to hand, C. Traaoc, C. labiata, C. Mossiae, C. Intermedia, C. Schroderae, C. speciosissima, C. Citrina, C. Gaskelliana, Laelia anceps, L. Albida, L. majalis, L. Autumnalis, Epidendrum Vittellinum majus, E. Cooperianum, Oocidium Crispum, O. Varicosum, O. Cavendishianum, O. Luridum, Odontoglossum, To arrive in a short time, C. Dowiana, C. Aurea, C. Warneri, Miltonia Vexillaria.
GARRILLO & BALDWIN SEGAUCUS, N. J.

ORCHIDS for Spring Delivery

NEW IMPORTATIONS
Cattleyas, Laelias, Oncidium, etc.
WRITE FOR PRICES
Now is the time to Pot Orchids. Best Quality of Peat, Moss and Baskets on hand.
JOSEPH A. MANDA, 191 Valley Road, WEST ORANGE N. J.

ORCHID IMPORTATIONS

Write at once for our quotations on all
FOR 1908 DELIVERY
JULIUS ROEHRS CO.,
The Orchid Nurseries, Rutherford, N. J.

ORCHIDS

We are at present booking orders for freshly imported Orchids for delivery 1908, of all leading kinds at reduced prices. We have just received the following:—
Oncidium Sarcodes, O. Forbesii, O. Tigrinum and Sophronites, Grandiflora and Coccinea.

LAGER & HURRELL, Summit, N. J.

NEPHROLEPIS SCOTTII

in the following sizes, extra good value
25c., 50c., 75c., and \$1
Grand Specimen Plants at \$3, \$4, \$5, \$6.

JOHN SCOTT
Rutland Road and E. 45th St.
Tel. 2800 Bedford BROOKLYN, N. Y.

NEP. WHITMANI

2¼ in., \$5.00 per 100

NEP. WHITMANI

3½ in., \$25.00 per 100

BOSTON FERNS

2¼ in., \$3.00 per 100

H. H. BARROWS & SON Whitman, Mass.

FERNS

Boston, 4 inch 12c, 5 inch 25c.
Piersonii, 3 inch 8c.
Elegantissima, 2¼ inch 6c, 3 inch 10c, 4 inch, 15c.

BAUR FLORAL CO., Erie, Pa.

ASPARAGUS

Plumosus Nanus

Seedlings from Flats, \$10.00 per 1000

A. N. PIERSON, CROMWELL, CONN.

JAPANESE
THE YOKOHAMA NURSERY CO. NEW YORK.
31 BARCLAY STR.
LILIES
PLANTS
BAMBOO STAKES

OBITUARY.

James Daly.

James Daly, who has been a familiar figure to the frequenters of the New York flower markets for many years, died on February 14, at the age of 43. He had been in the employ of Jas. Weir's Sons, Brooklyn, for a quarter of a century.

William McManus.

William McManus, father of James McManus, wholesale florist of New York, died on February 14 after a brief illness, aged 68. Mr. McManus was born in Ireland, and came to this country many years ago. A widow and two sons survive him.

Robert Allan.

Robert Allan became seriously ill last Saturday and was removed to the Newport Hospital where, without regaining consciousness, he passed away on the evening of Monday, 24th inst. He was a brother of William Allan (gardener at Dr. Jacob's estate) whose son died about two weeks ago. Robert Allan was popular with all classes in the community and his friends were many. A few years ago he was gardener on the estate of E. C. Knight on Bellevue Ave., Newport. Besides the brother above-mentioned, he leaves a widow to whom the keenest sympathy is felt. He was thirty-eight years of age. D. M.

NEWS NOTES.

Whitter & Co. have been awarded the contract for bulbs for the park department of Lowell, Mass.

G. A. Kishpaugh of Iola is starting in the greenhouse business at Independence, Kansas, with C. W. Lemmon as manager.

A. L. Randall Co. of Chicago have leased the four floors of the building they now occupy and contemplate making extensive improvements in their supply department.

I. Racz has purchased a place at Marshfield, Mass., and will begin business with the growing of vegetables and small fruits, later to take up ornamental stock and erect a range of greenhouses. He would be glad to receive catalogues and price lists from wholesale dealers.

J. W. Shadlow, proprietor of the Cedar Hill Nursery and Orchard Co., Winchester, Tenn., has made a voluntary assignment to Hugh Morton, trustee. The estimated cash value of the assets is \$60,000, and liabilities \$42,000. The company did an annual business of \$250,000. The business will be continued by the trustee, and it is said the obligations can be met within a year.

FIRE RECORD.

Bennett & Peters, Paola, Kansas, greenhouse damaged to the extent of \$200.

Goodwin Bros. Pottery Co. Elmwood, Conn., had their factory destroyed re-

Baskets for Florists

COLES & COMPANY

109 and 111 Warren St., Established 1884 NEW YORK

BERRY BASKETS

...Write for Catalogue... FRUIT PACKAGES, etc.

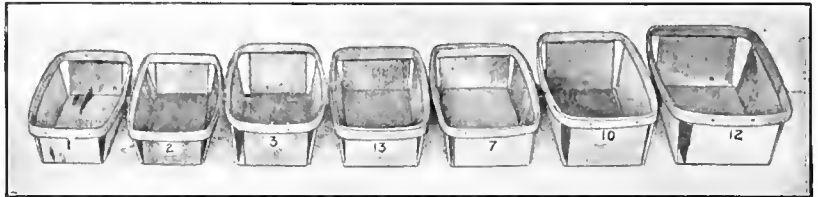

TILL OR VERBENA BASKETS

No. 1 is 8½ in. long, 4½ inches wide, 2½ inches deep, packed 500 in a crate, per 1000, \$ 7.50
 No. 2 is 9½ in. long, 5 in. wide, 3 inches deep, packed 500 in a crate, per 1000, 8.00
 No. 3 is 9½ in. long, 5½ inches wide, 3½ inches deep, packed 500 in a crate, per 1000, 8.00
 No. 13 is 10 in. long, 5½ inches wide, 3 inches deep, packed 500 in a crate, per 1000, 8.00
 No. 11 is 10½ in. long, 6 inches wide, 4 inches deep, packed 500 in a crate, per 1000, 9.00
 No. 12 is 11 in. long, 7 inches wide, 4 inches deep, packed 500 in a crate, per 1000, 10.00

With detached wire handles if required, \$2.00 per 1000 additional.

Made of Selected White Wood.

Special Sizes Made to Order.

BOXWOOD

Finest quality, \$17.50 per Cwt.

GALAX Green, \$1.00 per 1000; \$7.50 per 10,000.
 Bronze, \$1.00 per 1000; \$7.50 per 10,000.

Hardy Ferns, Best Grade, \$1.50 a 1000

LAUREL, MOSS, PRINCESS PINE, FESTOONING.

N. F. McCARTHY & CO. Telephone 5973-5974 Main 84 HAWLEY ST., BOSTON
 Largest Dealers in Florists' Supplies in New England

cently, and lost all machines, molds, etc.

P. J. Sinclair, florist, Toronto, Can., lost \$5,000 in a fire of unknown origin on February 18. He was well insured.

The greenhouse of Victor Maret, Lowell, Mass., was discovered to be on fire on the morning of February 20, but prompt work soon extinguished the flames.

Fire was discovered in the Howe block, Lowell, Mass., on February 18, over the flower store of James McManmon, but fortunately his stock was not injured.

KORAL SCRIPT LETTERS AND EMBLEMS

ONCE USED ALWAYS USED
 For sale by all first-class supply houses. Made by

KORAL MFG. CO.
 26 Hawley St., Boston

E. A. BEAVEN

Southern Wild Smilax, Log Mosses,

Natural and Perpetuated — at Wholesale,

EVERGREEN, ALABAMA.

BOSTON FLORIST LETTER CO.

Manufacturers of FLORISTS' LETTERS

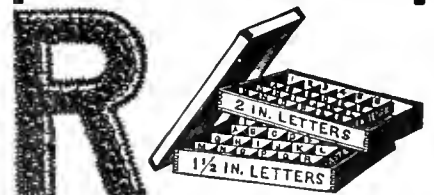

This wooden box nicely stained and varnished, 18x30x12, made in two sections, one for each size letter, given away with first order of 500 letters

Block Letters, 1½ or 2 inch size per 100, \$2.
 Script Letters, 3. Fastener with each letter or word. Used by leading florists everywhere and for sale by all wholesale florists and supply dealers

N. F. McCARTHY, Manager
 66 Pearl Street, BOSTON, MASS.

In ordering goods please add "I saw it in HORTICULTURE."

The "Japana" Cut Flower Holder

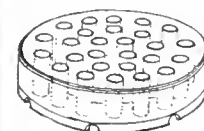

A handy article for florists. Sells to the trade on sight. Made of glass in three sizes. The "Anglais" Table Decoration, something entirely new, long needed. The florist and housewife will appreciate this article, as it simplifies the art of table decorating.

Ask for catalog.

M. V. CARNSEY, Dept. F,
 130 Waiola Ave., La Grange, Ill.

**JOHN BREITMEYER'S
SONS**
Cor. Miami and Gratiot Aves.
DETROIT, MICH.
**Artistic Designs . . .
High Grade Cut Blooms**
We cover all Michigan points and good
sections of Ohio, Indiana and Canada

P. J. and J. E. HAUSWIRTH
232 Michigan Ave.
CHICAGO
AUDITORIUM ANNEX Tel. Harrison 585

SAMUEL MURRAY
Florist
Coates House Conservatory
1017 BROADWAY, KANSAS CITY, MO
Both 'Phones 2670 Mafn

FRED C. WEBER
FLORIST
4326-28 OLIVE STREET ST. LOUIS, MO.
Established 1873
Long Distance Phone Bell Lindell 676



WASHINGTON,
D. C.
GUDE'S
GUDE BROS CO
FLORISTS
1214 F ST NW
WASHINGTON DC

Geo. H. Cooke
FLORIST
Connecticut Avenue and L Street
WASHINGTON, D. C.

The Park Floral Co.
J. A. VALENTINE
Pres.
DENVER, COLORADO

WILLIAM L. ROCK
FLOWER CO.
KANSAS CITY, - MO.
will carefully execute orders for Kansas City
and any town in Missouri or Kansas.

ALBANY, N. Y.
EYRES
Flowers or Design Work
DELIVERED IN ALBANY AND VICINITY
ON TELEGRAPHIC ORDER.
11 NORTH PEARL ST., ALBANY, N. Y.

BUSINESS CHANGES.
The Perth Floral Co., Mason City, Ia., has moved to Poplar and B streets.
J. R. Bather, Clinton, Ia., has purchased the florist business of Mrs. M. E. Eaton at Lyons.
Sawyer & Payne, Jacksonville, Fla., are planning to start in the nursery business in the spring.
J. L. Hartwell, Dixon, Ill., has taken his son Robin into partnership, and the firm name is J. L. Hartwell & Son.
C. Klopfer has withdrawn from the firm of Klopfer & Nelson, Peoria, Ill., but it is stated that he is looking for a new location in which to open business.

NEW RETAIL FLOWER STORES.
Main Line Flower Shop, Ardmore, Pa.
Ferdinand Link, Shelby St., Louisville, Ky.
A. C. Oelschig & Sons, 147 Bull St., Savannah, Ga.
Miss East, 10th St. & North Ave., Baltimore, Md.

LEADING RETAIL FLORISTS—
Index by Towns will be found in Buyers' Directory.



BOSTON'S BEST
In Quality and Design
Can be relied upon when you transfer your retail orders to

EDWARD MACMULKIN
194 Boylston Street, Boston

Send flower orders for delivery in
BOSTON
and all
NEW ENGLAND POINTS
THOS. F. GALVIN
124 Tremont St., Boston

TRANSFER
Your orders for flower or plant delivery in Eastern New England to
JULIUS A. ZINN,
2 Beacon St., Boston.
Fine Design Work a Specialty.

YALE Orders for flower deliveries to Yale College and all other Connecticut points carefully filled and delivered by
J. N. CHAMPION & COMPANY
1026 CHAPEL STREET NEW HAVEN, CONN.

ATLANTA FLORAL CO.
41 Peachtree Street, ATLANTA GEORGIA.

Florists Out of Town
Taking orders for delivery in **New York or Vicinity** can have them filled in best manner and specially delivered by
Thomas Young, Jr.
500 Fifth Ave., New York City
Telephone 847 Bryant.

ALEX. McCONNELL
571 FIFTH AVENUE
NEW YORK CITY
Telegraphic orders forwarded to any part of the United States, Canada, and all principal cities of Europe. Orders transferred or intrusted by the trade to our selection for delivery on steamships or elsewhere receive special attention.
Telephone Calls, 487 and 488 38th St.
Cable Address, ALEXCONNELL

William J. Smyth
FLORIST
Cor. Michigan Ave. and 31st St., CHICAGO
We ship to all points in Illinois and Iowa.
Phones: Douglas 744, Douglas 523, Douglas 740

WILLIAM H. DONOHOE
FLORAL DECORATOR
17 East 28th St., New York
Special Attention to Theatre and Steamer Orders, and reliable deliveries guaranteed.

DAVID CLARKE'S SONS
Deliver orders from any part of the country to
New York City
Or OUT-GOING STEAMERS
Write or telegraph
2139-2141 Broadway, New York
Telephone 1552-1553 Columbus

**PROMPT DELIVERY IN
BOSTON**
AND ALL NEW ENGLAND POINTS
HOUGHTON & CLARK
396 Boylston St., Boston, Mass.

Flower Deliveries
In Brooklyn and other Long Island Points New York City, New Jersey, etc. At Theatres, Hotels, Steamers or Residences.
WILSON
Fulton St. and Greene Ave., Brooklyn, N.Y.

YOUNG & NUGENT
42 West 28 St., NEW YORK
"FLOWERS BY TELEGRAPH"
JACOB SCHULZ, 644 Fourth Ave., LOUISVILLE, KY.
Cut Flowers of BEST QUALITY in season delivered promptly to any address.
Write, Telegraph or Telephone.
Cumberland and Home Phones 223 and 984

EASTER PLANTS

**Azaleas, Baby Ramblers,
Hydrangeas, Lilies,
Geraniums**

In fine condition. Write for Prices

WM. W. EDGAR CO., Waverley, Mass.

ACACIA PUBESCENS

A choice and seasonable specialty, long sprays of shimmering gold. Prices on application.

CHOICE VALLEY WHITE VIOLETS

\$3.00 and \$4.00 per 100 \$1.50 per 100

S. S. PENNOCK - MEEHAN CO.
1608-1620 Ludlow St. PHILADELPHIA

"The" Wholesale Florists of Philadelphia

EVERYTHING SEASONABLE IN
CUT FLOWERS
EDWARD REID, Wholesale Florist
1526 Ranstead St., PHILADELPHIA
STORE CLOSERS 8 P. M.

CHAS. W. MCKELLAR

51 WABASH AVE., CHICAGO

Western Headquarters for Choice Orchids
Valley, Roses and all Cut Flowers

PETER REINBERG WHOLESALE

CUT FLOWERS

51 Wabash Av., Chicago, Ill.
In writing advertisers, mention Horticulture

CUT FLOWER BOXES
EDWARDS FOLDING BOX CO
MANUFACTURERS
PHILADELPHIA, PA.

AMERICAN BEAUTY and all other ROSES

**LILY OF THE VALLEY, CARNATIONS
WELCH BROS., 226 Devonshire St., Boston, Mass.**

AMERICAN BEAUTIES
Fancy BRIDES and MAIDS
W. E. MCKISSICK WHOLESALE FLORIST
PHILADELPHIA
1619-1621 RANSTEAD ST.

DAILY CONSIGNMENTS
From 40 to 60 Growers
We can care for your outflower wants to advantage.
E. F. WINTERSON CO.
45-47-49 WABASH AVE., CHICAGO

J. J. HARTY & COMPANY
WHOLESALE AND COMMISSION FLORISTS
3112 G Street, N. W., Washington, D. C.

WHOLESALE FLOWER MARKETS—TRADE PRICES—Per 100 TO DEALERS ONLY

	CHICAGO Feb. 24	TWIN CITIES Feb. 24	PHILA. Feb. 24	BOSTON Feb. 26
ROSES				
Am Beauty, Fancy and Special...	50.00 to 60.00	40.00 to 50.00	40.00 to 75.00	50.00 to 60.00
" " Extra.....	30.00 to 40.00	30.00 to 40.00	25.00 to 30.00	30.00 to 40.00
" " No. 1.....	20.00 to 25.00	20.00 to 30.00	15.00 to 20.00	15.00 to 25.00
" " Lower grades.....	4.00 to 8.00	8.00 to 15.00	5.00 to 10.00	4.00 to 10.00
Bride, 'Maid, Fancy & Spectal....	8.00 to 10.00	8.00 to 12.00	10.00 to 15.00	8.00 to 10.00
" " Extra and No. 1.....	6.00 to 8.00	6.00 to 7.00	6.00 to 10.00	4.00 to 6.00
" " Lower grades.....	4.00 to 6.00	4.00 to 5.00	3.00 to 5.00	2.00 to 3.00
Killarney, Richmond, Fan, & Sp...	8.00 to 10.00	8.00 to 12.00	12.00 to 20.00	8.00 to 12.00
" " Lower grades.....	4.00 to 6.00	4.00 to 6.00	3.00 to 10.00	2.00 to 6.00
Chat'nay, Wellesley, Fan, & Sp...	6.00 to 8.00	8.00 to 12.00	10.00 to 15.00	8.00 to 10.00
" " Lower grades.....	4.00 to 6.00	4.00 to 6.00	4.00 to 8.00	2.00 to 6.00
Golden Gate, Ivory.....	4.00 to 8.00	4.00 to 8.00	4.00 to 12.00	2.00 to 8.00
CARNATIONS				
Fancy and Novelties.....	2.00 to 3.00	2.00 to 4.00	2.50 to 6.00	2.00 to 3.00
Ordinary.....	1.00 to 1.50	1.50 to 2.00	1.00 to 3.00	1.00 to 2.00
MISCELLANEOUS				
Violets.....	.50 to .75	.50 to 1.25	.25 to 1.00	.35 to .60
Cattleyas.....	50.00 to	40.00 to 50.00	5.00 to 60.00	50.00 to 60.00
Cypripediums.....	1.00 to	12.00 to 15.00	1.50 to 15.00	8.00 to 10.00
Lilies.....	8.00 to 12.00	10.00 to 12.00	10.00 to 15.00	8.00 to 12.00
Lily of the Valley.....	2.00 to 3.00	2.00 to 3.00	2.00 to 5.00	2.00 to 3.00
Freesia.....	2.00 to	2.00 to 3.50	1.00 to 4.00	.50 to 2.00
Roman Hy, Paper White Nar....	2.00 to 3.00	2.00 to 3.00	1.50 to 3.00	1.00 to 2.00
Daffodils.....	2.00 to 3.00	2.00 to 2.00	1.50 to 3.00	1.00 to 2.00
Tulips.....	2.00 to 4.00	2.00 to 4.00	4.00 to 5.00	1.00 to 3.00
Mignonette..... to 6.00	4.00 to 8.00	2.00 to 5.00	3.00 to 4.00
Gardenias.....	25.00 to 35.00	35.00 to 50.00	35.00 to 50.00	25.00 to 40.00
Lilac per bunch.....	1.00 to 1.50 to 1.50	.25 to 2.00	1.00 to 1.50
Sweet Peas.....	.50 to 1.00	.50 to 1.00	.50 to 1.00	.50 to 1.00
Adiantum.....	.50 to 1.00	.75 to 1.00	1.00 to 1.50	1.00 to 1.50
Whitmanii Frods..... to to to 3.00	2.00 to 3.00
Smilax.....	10.00 to 12.00	12.00 to 15.00	12.00 to 20.00	10.00 to 12.00
Asparagus Plumosus, striogs....	35.00 to 50.00	35.00 to 50.00	50.00 to 75.00	25.00 to 50.00
" " & Soren. (too behs.)	35.00 to 50.00 to 35.00	35.00 to 50.00	15.00 to 50.00

THE FLORISTS' SUPPLY HOUSE OF AMERICA

Without a rival in knowledge of the requirements of the trade and the ability to supply them. Our New Illustrated Catalogue, recognized as a work of art unprecedented in its line for variety, novelty and completeness, tells the story fully, and if you have not yet sent for it, do so now.

'TIS FREE TO EVERYBODY IN THE TRADE

H. BAYERSDORFER & CO., 1129 Arch St., Philadelphia, Pa.

FLOWER MARKET REPORTS

BOSTON Although Friday and Saturday of last week and Monday of this week developed a little activity in buying, yet no permanent improvement in market conditions is visible. At time of publication things are pretty dull and the receipts continue heavy; accumulations are moved with difficulty and, as a rule, at very low figures. Roses hold prices better perhaps than any other staple, but they are increasing in quantity daily. As to quality, it may be truthfully stated that never have the flowers in this market been better. This statement applies to all classes generally. High grade material is in evidence everywhere, even on the curbstone stands.

The past week was a most eventful one for florists. On Thursday we had a blizzard—the worst since 1885—and at some greenhouses considerable damage was done by the weight of snow on the glass. Trains being delayed caused many market shipments to come in late. Retail business was at a standstill, it being impossible for customers to venture out for several days. Carnations glut the market. New York violets are being sold at any price available. Bulbous stock is very plentiful. With roses it is another story. Brides and Bridesmaids are scarce, but of fine quality; Beauties are also very scarce but of poor quality, most of the growers of the rose being off crop, but expecting to be in for Easter. Among the spring flowers noted are white and purple lilac, dentzia, and bridal wreath. Callas and lilies are most abundant. Sweet peas, when they have long stems, bring a good price, but short ones are a glut. It is drawing close to the Mardi Gras Festival at New Orleans and shippers anticipate a good business from that section.

Stock is accumulating to a great extent here, with the exception of roses and violets. A heavy demand on hardy ferns finds first-class supply, but such greens as asparagus and smilax are at a premium.

Business in the wholesale cut flower marts shows but little improvement over that of last week. The holiday on Saturday helped to clean up some of the accumulation and Monday's pulse seemed to throb with a little more vigor than customary, but, on the whole, there is nothing in evidence on which to base a statement that business has improved. Carnations, violets and all bulbous stock except lilies continue in over supply; the latter are scarce. Of roses there are enough, but no great surplus, and the quality is excellent. A small quantity of *Acacia pubescens* is being received. *Prinnia obconica* is a frequent object in the florists' windows, and the scare regarding the poisonous qualities of this pretty plant seems to have in a measure died out.

PHILADELPHIA A more cheerful feeling prevails in the wholesale markets here. Not that I see any great improvement in conditions but I think the dealers are accommodating themselves to the change. Washington day brightened things up a little. The weather has been favorable and lots of stock has been moved off through the usual auxiliary channels. American Beauty roses are off crop for the time being, and prices have hardened up a little. The prospects are for plenty of these again very shortly. Other varieties are moving well but without change in quoted rates. The rose situation is improved considerably, but no change for the better can be reported on carnations. Lily of the valley market is poor. Violets in fairly good demand—especially on mild days when the street men can work. Sweet peas are still too plentiful. Orchids are in good demand. *Cattleya Schroederiae* is the leader at present. *Cypripediums* are more plentiful than usual for the season. Lilies if good find a market. Daisies, myosotis, and such spring subjects are in fair demand. Bulbous stock shows no improvement and supplies remain much in excess of demand.

During the latter part of last week there was an unusual business activity here. A good many large social affairs and prominent funerals have called for an unusual amount of cut flowers. All stores are kept agreeably busy. With the exception of American Beauty roses all stock is plentiful, and prices keep up amazingly well for so late in the season. There is an abundance of bulbous stock but quite a dearth of greens of the better class.

CARNATION LIEUT. PEARY.

Referring to the note in last week's HORTICULTURE concerning the alleged tendency of carnation Lieut. Peary to "go to sleep" on the plants under certain conditions, Mr. C. W. Ward advises that a temperature of from 52 to 55 be given this variety, with plenty of ventilation. He finds it resentful of overwatering, and if soil is kept soaked trouble is liable to ensue. With him Lieut. Peary has always proved to be an excellent keeper and has made a good record in cash returns. From 250 running feet of bench, averaging 4 feet in width, the returns this season from September to February 15th have been \$425, which Mr. Ward considers satisfactory.

GREENHOUSES BUILDING AND CONTEMPLATED.

Hannibal, Mo.—Lee Hodges, one house.

Chicago, Ill.—H. F. Halle, 25-ft. conservatory.

Jacksonville, Fla.—Sawyer & Payne, three houses.

N. Augusta, Me.—Percival Bros., range of houses.

E. Sandwich, Ont.—J. H. Smith, range of houses.

Ludington, Mich.—Wm. Gregory, range of houses.

Rock Island, Ill.—Ludwig Stapp, carnation house, 51x160.

PHILADELPHIA NOTES.

D. D. L. Farson has opened a flower store at Ardmore, under the title of the Main Line Flower Shop.

M. Kavanagh, for many years a prominent member of the Craig forces, has been seriously ill since Christmas.

On Tuesday evening, March 3rd, the Florists' Club will be addressed by Mr. J. Otto Thilow, his subject being "New Things in an Old Country."

Alexander B. Scott has just returned from his usual mid-winter trip, greatly benefited in health and now ready for a strenuous season. Mrs. Jardine is his leading lady this year. Hamakichi Suzuki, of Yokohama, Japan, and Chas. Loechner have been visiting the seed trade in the interests of the Yokohama Nursery Co. this week. C. W. Scott, of Chicago, was also a visitor.

W. Kleinheinz is recovering rapidly from the severe attack of rheumatism from which he has been confined to his room since December 29, and expects to attend the rose show in Chicago in March.

Mrs. Jardine will be among the exhibits at the Boston Market Flower Show on the 29th inst. W. P. Craig will be cicerone. Any New England rose grower wishing to see for himself should embrace this easy opportunity.

SAVE
your weekly copies of this paper.
DON'T

throw them away.
The contents are always of PERMANENT VALUE and you may need them for reference tomorrow, a year from tomorrow, or still later.

Alex Mann, Jr. Co. Inc.

Wholesale Dealer in

Florists' Supplies and Cut Flowers

White Doves, \$9.00 per doz.
Galax Leaves.

1125 Polk Street, San Francisco, Cal.

J. B. Murdoch & Co.

Wholesale Florists

FLORISTS' SUPPLIES

714 Penn Ave., PITTSBURG, PA.

Long Distance Phone 1435 Court.

J. KOPELMAN & CO.

Wholesale Dealers in

Cut Flowers and Florists' Supplies EVERGREEN AND FERN LEAVES

OF ALL KINDS.

21 Washington St., PROVIDENCE, R. I.
Telephone Connection.

ROBERT J. DYSART,

Public Accountant and Auditor

Simple methods of correct accounting especially adapted for florists' use.

Books Balanced and Adjusted

Merchants Bank Building

28 STATE ST., BOSTON

Telephone, Main 58

The KERVAN CO.

113 W. 28th ST.
New York

WHOLESALE DEALERS

Fresh cut Palmetto & Cycas Palm Leaves, Galax, Leucothoe, Ferns and Mosses. All Decorating Evergreen.

JOHN YOUNG
WHOLESALE FLORIST
 Finest American Beauties and Carnations
 51 West 28 St. - NEW YORK

FORD BROTHERS
 48 West 28th Street, NEW YORK
FINE ROSES FANCY CARNATIONS
 A Full Line of All CUT FLOWERS
 Telephone, 3870 or 3871 Madison Square

H. E. FROMENT,
 Wholesale Commission Florist,
 Choice Cut Flowers,
 57 West 28th St., :: NEW YORK.
 Telephones: 2200, 2201, Madison Square.

The Reliable Commission House
 Richmond Roses and Rich Flowers
 of all varieties
JOS. S. FENRICH
 110 W. 28th Street, New York
 Tel. 324-325 Madison Square

Established 1891 BUY FROM SHIP TO TRY **ME**
ALFRED H. LANGJAHR
 All Choice Cut Flowers in Season
 55 West 28th St., New York
 Telephone 3924 Madison Square.

JOHN I. RAYNOR
Wholesale Commission Florist SELLING AGENT FOR LARGEST GROWERS
 A full line of Choice Cut Flower stock for all purposes. Comprises every variety grown for New York market, at current prices
 TEL. 1998 MADISON SQUARE 49 W. 28 St., New York City

Walter F. Sheridan
 Wholesale Commission Dealer in
CHOICE CUT FLOWERS
 39 West 28th Street, New York
 Telephone: 3532-3533 Madison Square

HEADQUARTERS FOR NOVELTIES
ORCHIDS A SPECIALTY
 THE HIGHEST GRADE OF **VALLEY** ALWAYS ON HAND
 GARDENIAS, DAISIES, ROSES AND CARNATIONS
JAMES McMANUS, Telephone 759 Mad. Sq. 42 W. 28th St., New York

PHILIP F. KESSLER 55 & 57 W. 26th St., New York City
 Commission Dealer, Wholesale Buyer and Seller of
CUT FLOWERS
 Open from 5 a. m. to 6 p. m. Sunday till 10 a. m.
 Tel., 5243 and 2921 Madison Sq. Res., 345 J., Newtown.
Finest Lilies in the Market Every Day in the Year.

WHOLESALE COMMISSION FLORIST **J. K. ALLEN** 106 W. 28 ST. NEW YORK
 Telephone 167 Madison Sq.
 OPEN 6 A.M. DAILY
 We have a good regular outlet for seasonable flowers

NEW YORK QUOTATIONS PER 100—TO DEALERS ONLY

	Last Half of Week ending Feb. 22 1908	First Half of Week beginning Feb. 24 1908		Last Half of Week ending Feb. 22 1908	First Half of Week beginning Feb. 24 1908
Roses			Cattleyas	25.00 to 50.00	40.00 to 60.00
Am. Beauty, fan and sp.	40.00 to 50.00	40.00 to 50.00	Cypripediums	6.00 to 8.00	8.00 to 10.00
" extra	10.00 to 15.00	20.00 to 30.00	Lilies	6.00 to 10.00	10.00 to 12.00
" No. 1.....	8.00 to 10.00	8.00 to 15.00	Lily of the Valley	1.00 to 2.00	1.00 to 2.00
" Lower grades	1.00 to 2.00	2.00 to 4.00	Freesia	1.00 to 2.00	1.00 to 1.50
Bride, 'Maid, fan and sp.	6.00 to 10.00	6.00 to 8.00	Roman Hy., Paper White Nar. ...	1.00 to 2.00	1.00 to 1.00
" " extra	1.00 to 5.00	1.00 to 5.00	Daffodils	1.00 to 1.50	1.00 to 1.00
" " lwr. grs.	1.00 to 2.00	2.00 to 3.00	Tulips	1.00 to 2.00	1.00 to 2.00
Killbuck, Richmond, fancy & spec	6.00 to 10.00	6.00 to 10.00	Rignonette	2.00 to 4.00	2.00 to 4.00
" " lower grades	1.00 to 2.00	2.00 to 4.00	Gardenias	10.00 to 25.00	15.00 to 35.00
Chatenay, Wellesley, fan, and spec.	6.00 to 10.00	6.00 to 10.00	Lilac per bunch to .75 to .75
" " lower grades	1.00 to 2.00	2.00 to 4.00	Sweet Peas50 to .75	.50 to .75
Golden Gate, Ivory.....	1.00 to 6.00	2.00 to 6.00	Adiantum75 to 1.50	.75 to 1.50
Carnations, Fancy and Novelties. .	1.00 to 2.00	1.00 to 2.00	Smilax	8.00 to 10.00	8.00 to 12.00
" Ordinary to .50	.50 to .75	Asparagus Plumosus, striggs	25.00 to 40.00	25.00 to 40.00
Violets25 to .25	.20 to .35	" " & Sprea. (100 bchs.)	10.00 to 15.00	20.00 to 35.00

B. S. SLINN, Jr.
 —WHOLESALE FLORIST—
 55 & 57 W. 26th St., New York City
 Tel., 3864 Madison Sq. Shipping Orders Solicited.
VIOLETS Roses and Carnations

Edward C. Horan
 Wholesale Florist
 55 WEST 28th ST.
 Tel. 1462 1463 Madison Square New York

TRAENDLY & SCHENCK
WHOLESALE FLORISTS
 Furnish best stock at fair prices all the year round Send for quotations on fall orders
 Tel. 798-799 Madison Sq. 44 West 28th Street, New York City

Alexander J. Guttman
THE WHOLESALE FLORIST OF NEW YORK
 43 WEST 28th STREET
 PHONES. 1664--1665 MADISON SQUARE
ENOUGH SAID



HARDY CUT FERNS

Sphagnum Moss, Extra Large Bales, per bale, \$1.25. Fancy and Dagger Ferns our specialty. A trial order will convince you that we ship only first-class stock. Headquarters for Florists' supplies and wire work. All cut flowers in season. **BOXWOOD**, per bunch 35c, 50 lbs. \$7.50.

MICHIGAN CUT FLOWER EXCHANGE, INC., All 'phone connections 38-40 Broadway, Detroit, Mich.

FANCY and DAGGER
Extra fine, \$1.50 per 1000. Bronze and Green Galax, \$1.25 per 1000. Leucothoe Sprays, \$1.00 per 100, \$7.50 per 1000.

Headquarters in Western New York
FOR
ROSES, CARNATIONS
And all kinds of Seasonable Flowers
Wm. F. Kasting Co.
Wholesale Commission Florist, also Dealer in Florists' Supplies and Wire Designs.
383-87 ELLICOTT ST. BUFFALO, N. Y.
Give us a trial. We can please you.

FRANK S. HICKS & CO.
Wholesale Florists.
Open Now for Consignments of Cut Flowers.
52 West 28th Street, - New York City
Tel. 2920 Mad. Sq.

FRANK MILLANG
Wholesale Florist
Telegraphic Orders Filled and Delivered.
55-57 West 26th St., New York City.

HENRY M. ROBINSON & CO.
Wholesale and Commission
FLORISTS
Hardy Cut Evergreens and Florists' Supplies
15 Province St. and 9 Chapman Place,
BOSTON, MASS.

Best Flowers
IN THE
BOSTON MARKET
N. F. McCarthy & Co.
84 Hawley St., BOSTON, MASS.
Send for Prices

WHOLESALE FLOWER MARKETS. PER 100. TO DEALERS ONLY.

	CINCINNATI Feb. 25	DETROIT Feb. 25	BUFFALO Feb. 25	PITTSBURG Feb. 24
ROSES				
Am. Beauty, Fan. and Sp.	25.00 to 30.00	25.00 to 35.00	30.00 to 50.00	50.00 to 60.00
" Extra	10.00 to 15.00	15.00 to 20.00	15.00 to 30.00	35.00 to 40.00
" Lower grades	4.00 to 6.00	6.00 to 15.00	5.00 to 10.00	15.00 to 20.00
Bride, 'Maid, F. & S.	8.00 to 10.00	8.00 to 15.00	10.00 to 10.00	8.00 to 10.00
" Extra	6.00 to 8.00	4.00 to 6.00	6.00 to 6.00	6.00 to 8.00
" Low. gr.	4.00 to 5.00	4.00 to 4.00	3.00 to 4.00	4.00 to 5.00
Killarney, Richmond, Fan. & Sp.	8.00 to 10.00	8.00 to 12.00	10.00 to 10.00	10.00 to 12.00
" Lower grades	4.00 to 6.00	4.00 to 6.00	3.00 to 6.00	6.00 to 8.00
Chateau, Wellesley, Fan. & Sp.	8.00 to 10.00	8.00 to 15.00	10.00 to 10.00	10.00 to 12.00
" Lower grades	4.00 to 6.00	4.00 to 6.00	7.00 to 10.00	6.00 to 8.00
Golden Gate, Ivory	6.00 to 8.00	4.00 to 6.00	3.00 to 3.00	6.00 to 8.00
CARNATIONS				
Fancy and Novelties	3.00 to 4.00	2.50 to 2.50	3.00 to 4.00	3.00 to 3.00
Ordinary	1.50 to 2.00	1.50 to 2.00	1.50 to 2.00	1.00 to 1.00
MISCELLANEOUS				
Violets	.50 to .75	1.00 to 1.50	.40 to .75	.50 to .75
Cattleyas	40.00 to 50.00	35.00 to 50.00	40.00 to 60.00	50.00 to 75.00
Cypripediums	12.00 to 15.00	12.00 to 15.00	10.00 to 15.00	10.00 to 15.00
Lilies	12.00 to 15.00	12.50 to 15.00	4.00 to 15.00	12.50 to 15.00
Lily of the Valley	3.00 to 4.00	3.00 to 4.50	2.00 to 4.00	3.00 to 4.00
Freesia	2.00 to 4.00	3.00 to 4.00	1.00 to 3.00	1.00 to 2.00
Romao Hy., Paper White Nar.	3.00 to 4.00	2.00 to 3.00	2.00 to 3.00	1.00 to 3.00
Daffodils	2.00 to 4.00	3.00 to 4.00	2.00 to 3.00	2.00 to 3.00
Tulips	3.00 to 4.00	3.00 to 4.00	2.00 to 3.00	1.00 to 3.00
Mignonne	6.00 to 8.00	4.00 to 8.00	2.00 to 5.00	2.00 to 4.00
Gardenias	35.00 to 50.00	35.00 to 50.00	25.00 to 40.00	40.00 to 50.00
Lilac per bunch	1.00 to 1.50	1.00 to 1.50	1.00 to 1.00	1.00 to 1.00
Sweet Peas	.50 to .75	1.00 to 2.00	.40 to 1.00	.50 to 1.00
Adiantum	1.00 to 1.00	1.50 to 2.50	.50 to 1.00	1.00 to 1.25
Whitmanii Fronds	1.00 to 1.00	1.00 to 1.00	3.00 to 10.00	10.00 to 10.00
Smilax	12.50 to 12.50	15.00 to 15.00	15.00 to 15.00	10.00 to 12.50
Asparagus Plumosus, strings	40.00 to 50.00	40.00 to 50.00	40.00 to 60.00	50.00 to 50.00
" " & Spren (100 bchs.)	25.00 to 35.00	25.00 to 35.00	25.00 to 50.00	10.00 to 25.00

SAMUEL A. WOODROW
WHOLESALE PLANTSMAN
Palms, Large and Small Ferns, etc.
53 West 30th Street, NEW YORK
Telephone 2083 Madison

WILLIAM H. KUEBLER
Brooklyn's Foremost and Best
WHOLESALE COMMISSION HOUSE
A First Class Market for all CUT FLOWERS
28 Willoughby St., Brooklyn, N. Y.
Tel. 4591 Main

CLEARY'S HORTICULTURAL CO.
Management AMBROSE T. CLEARY
Wholesale Contracting, Jobbing, Auction
HORTICULTURAL PRODUCTS
of every description.
Consignments Received. Surplus Stock Converted.
62 Vesey St., NEW YORK

Moore, Hentz & Nash,
Wholesale Commission Florists,
55 and 57 West 26th Street,
Telephone No. 756
Madison Square. **New York.**

H. C. BERNING
Wholesale Florist
1402 Pine Street, ST. LOUIS, MO.

MILLANG BROS.
WHOLESALE COMMISSION FLORISTS
41 West 28th Street
Telephone 3860 Madison
3861 **NEW YORK**

A. MOLTZ
Will purchase flowers on order in N. Y. market and ship carefully at prevailing wholesale prices. Address
55-57 West 26th Street, New York City

REED & KELLER
122 West 25th St., New York
Florists' Supplies
We manufacture all our
Metal Designs, Baskets, Wire Work & Novelties
and are dealers in
Glassware Decorative Greens and Florists' Requisites

In writing to Advertisers kindly mention Horticulture

Buyer's Directory and Ready Reference Guide

Advertisements under this head, one cent a word. Initials count as words.

Regular advertisers in this issue are also listed under this classification without charge. Reference to List of Advertisers will indicate the respective pages.

Buyers failing to find what they want in this list will confer a favor by writing us and we will try to put them in communication with reliable dealers.

ACCOUNTANT

R. J. Dysart, 28 State St., Boston.
For page see List of Advertisers.

ADIANTUMS

J. A. Peterson, McHenry Ave., Westwood, Cincinnati, Ohio.
Adiantum Farleyense.
For page see List of Advertisers.

ALTERNANTHERAS

Red Alternantheras at 40 cents per 100.
C. W. Moeckel, 17 Summer St., Fitchburg, Mass.

ARAUCARIAS

Godfrey Aeschmann, 1012 Ontario St., Philadelphia, Pa.
For page see List of Advertisers.

ASPARAGUS

A. N. Pierson, Cromwell, Conn.
Asparagus Plumosus Nanus.
For page see List of Advertisers.
Asparagus Plumosa, 2 in. pots. Fine plants, \$3.00 per 100; \$25.00 per 1000. Cash with order or good reference. Erle Floral Co., Erie, Pa.; or, Wm. F. Kasting Co., 385 Elliott St., Buffalo, N. Y.

AUCTION SALES

Cleary's Horticultural Co., 62 Vesey St., New York.
Horticultural Products of Every Description.
For page see List of Advertisers.

Sales every Tuesday and Friday. If you cannot attend send bids and shipping instructions. Catalogues on application. N. F. McCarthy & Co., 84 Hawley St., Boston.

AZALEAS

A. Leuthy & Co., Perkins St. Nurseries, Roslindale, Mass.
For page see List of Advertisers.

W. W. Edgar Co., Waverley, Mass.
For page see List of Advertisers.

August Rolker & Sons, New York, 31 Barclay St., or P. O. Box 752.
For page see List of Advertisers.

BAMBOO CANES

Stump & Walter Co., 50 Barclay St., New York.
For page see List of Advertisers.
Yokohama Nursery Co., 31 Barclay Street, New York.
For page see List of Advertisers.

BAY TREES.

Specimens and pairs, all sizes. Send for prices. N. F. McCarthy & Co., 84 Hawley St., Boston.

Bay Trees and Box Trees, standards and pyramids. All sizes. Price list on application. J. Roehrs Co., Rutherford, N. J.

BEDDING PLANTS

R. Vincent, Jr., & Sons Co., White Marsh, Maryland.
For page see List of Advertisers.

BEGONIAS

J. A. Peterson, McHenry Ave., Westwood, Cincinnati, Ohio.
Begonia Gloire De Lorraine.
For page see List of Advertisers.

BOILERS

BOILERS. "Burnham" Boilers made for greenhouse heating. Lord & Burnham, 1133 Broadway, N. Y.

BOXWOOD

Henry M. Robinson & Co., 15 Province St., Boston.
For page see List of Advertisers.

N. F. McCarthy & Co., 84 Hawley St., Boston, Mass.
For page see List of Advertisers.

BUILDING MATERIAL

BUILDING MATERIAL of all description for All Cypress, Semi-Iron, Iron Frame or Truss Houses. Hot Bed Sash and Frames. Lord & Burnham Co., 1133 Broadway, N. Y.

BULBS AND TUBERS

Joseph Breck & Sons, 47-54 N. Market St., Boston.
For page see List of Advertisers.

J. M. Thornburn & Co., 33 Barclay St., New York.
For page see List of Advertisers.

A. T. Boddington, 342 W. 14th St., N. Y.
For page see List of Advertisers.

Rickards Bros., 37 East 19th St., New York.
For page see List of Advertisers.

H. F. Michell Co., Philadelphia.
For page see List of Advertisers.

H. E. Fiske Seed Co., Faneuil Hall Sq., Boston.
For page see List of Advertisers.

James Vlek's Sons, Rochester, N. Y.
Fall Bulbs.
For page see List of Advertisers.

D. Rusconi, 128 W. Sixth St., Cincinnati, O.
Lilium Auratum, Roseum, Multiflorum.
For page see List of Advertisers.

Ang. Rolker & Sons, 31 Barclay St., New York.
Seasonable Import Plants and Bulbs.
For page see List of Advertisers.

K. Veltuys, Hillegom, Holland,
Represented by Felix Bosch, 260 Clarendon St., Boston.

Bulbs French and Dutch.
For page see List of Advertisers.

Yokohama Nursery Co., 31 Barclay St., New York.
Formosa Lilium Longiflorum.
For page see List of Advertisers.

Henry A. Dreer, 714 Chestnut St., Philadelphia.

Calla Elliottiana, Caladiums.
For page see List of Advertisers.

Dwarf Pearl tuberose, 50,000 No. 2, very fine bulbs, 4 in. in circumference. Write for prices. T. V. Rivenbark, Wallace, N. C.

CANNAS

The Conard & Jones Co., West Grove, Pa.
For page see List of Advertisers.

A. T. Boddington, 342 W. 14th St., New York.
For page see List of Advertisers.

Henry A. Dreer, 714 Chestnut St., Philadelphia.
For page see List of Advertisers.

Good Robusta, dark-leaved, at \$1.50 per 100; large clumps Burbank, Mile. Berat and Cinnabar, at \$2.00 per 100; Pennsylvania, at \$2.50 per 100. C. W. Moeckel, 17 Summer St., Fitchburg, Mass.

CARNATIONS

F. Dorner & Sons Co., Lafayette, Ind.
For page see List of Advertisers.

S. S. Skidelsky, 1741 N. 18th St., Philadelphia.
For page see List of Advertisers.

CARNATIONS—Continued

Chicago Carnation Co., Joliet, Ill.
For page see List of Advertisers.

F. R. Pierson Co., Tarrytown, N. Y.
Winsor and White Enchantress Rooted Cuttings.
For page see List of Advertisers.

H. A. Jahn, New Bedford, Mass.
Carnation Lloyd.
For page see List of Advertisers.

F. H. Kimberly, 631 Townsend Ave., New Haven, Conn.
For page see List of Advertisers.

John E. Haines, Bethlehem, Pa.
Carnations Imperial and Pink Imperial.
For page see List of Advertisers.

A. N. Pierson, Cromwell, Ct.
Carnation Winsor.
For page see List of Advertisers.

The Leo Nissen Co., 1209 Arch St., Philadelphia, Pa.
For page see List of Advertisers.

White Bros., Gasport, N. Y.
Winsor, White Enchantress.
For page see List of Advertisers.

Fair Maid Carnation cuttings, strong, \$1.40 per 100; 500 for \$7.50. C. W. Moeckel, 17 Summer St., Fitchburg, Mass.

Send for list of the best carnation cuttings. Wm. Ehmann, Jr., Corfu, N. Y.
Unrooted Lawson, Boston Market, \$5.00 per 1000; Hill, \$4.00 per 1000. Wm. Ehmann, Jr., Corfu, N. Y.

Carnation cuttings of all the leading varieties at the same price as any reliable firm. Write for prices before you look elsewhere. Wm. F. Kasting Co., 383 Elliott St., Buffalo, N. Y.

CHRYSANTHEMUMS

Chas. H. Totty, Madison, N. J.
Single Chrysanthemums.
For page see List of Advertisers.

Will have 100,000 rooted cuttings of the best 60 commercial varieties ready about March 25. Have your orders booked now. Postal will bring new price list. Satisfaction guaranteed. W. Ehmann, Corfu, N. Y.

CONIFERS

John Waterer & Sons, Ltd., American Nursery, Bagshot, Eng.
For page see List of Advertisers.

Write for prices on all choice ornamental conifers. N. F. McCarthy & Co., 84 Hawley St., Boston, Mass.

CUT FLOWER BOXES.

Edwards Folding Box Co., Philadelphia.
For page see List of Advertisers.

Folding cut flower boxes, the best made. Write for list. Holton & Hunkel Co., Milwaukee, Wis.

DAHLIAS

David Herbert & Son, Atco, N. J.
For page see List of Advertisers.

J. L. Moore, Northboro, Mass.
For page see List of Advertisers.

Henry A. Dreer, 714 Chestnut St., Philadelphia.

Dahlia Souvenir de Gustave Doazan.
For page see List of Advertisers.

15,000 Field-grown clumps 2c. and up. List ready. H. W. Koerner, Sta. B, Milwaukee, Wis.

DECORATIVE PLANTS

A. Leuthy & Co., Roslindale, Mass.
For page see List of Advertisers.

For List of Advertisers See Page 284

EASTER PLANTS

Wm. W. Edgar Co., Waverley, Mass.
For page see List of Advertisers.

EVERGREENS

The New England Nurseries, Bedford, Mass.
For page see List of Advertisers.

FERNS

A. Leuthy & Co., Roslindale, Mass.
For page see List of Advertisers.

H. H. Barrows & Son, Whitman, Mass
Nephrolepis Whitmani.
For page see List of Advertisers.

Godfrey Aschmann, 1012 Ontario St., Philadelphia, Pa.
For page see List of Advertisers.

John Scott, Brooklyn, N. Y.
For page see List of Advertisers.

Baur Floral Co., Erie, Pa.
For page see List of Advertisers.

Nephrolepis Exaltata Bostoniensis, fine young plants, \$10.00 per 1000.
N. Elegantiissima, young plants \$15.00 per 1000. Send for price list. Soar Bros. Little River, Fla.

FERTILIZERS

Polverized Manure Co., 31 Union Stock Yards, Chicago, Ill.
Wizard Brand Cattle Manure.
For page see List of Advertisers.

Thos. J. Grey & Co.,
32 and 33 South Market St., Boston.
High-Grade Scotch Soot.
For page see List of Advertisers.

FLORAL PHOTOGRAPHS

Floral Photographs. Foley's 226-228 1-2 Bowery, New York.

FLORISTS' LETTERS.

Boston Florist Letter Co., 68 Pearl St., Boston, Mass.
For page see List of Advertisers.

Koral Mfg. Co., 26 Hawley St., Boston.
For page see List of Advertisers.

FLORISTS SUPPLIES

H. M. Robinson & Co., 15 Province St. and 9 Chapman Pl., Boston, Mass.
For page see List of Advertisers.

The Kervan Co., 113 W. 28th St., N. Y.
Decorative Evergreens.
For page see List of Advertisers.

Reed & Keller, 122 W. 25th St., New York.
For page see List of Advertisers.

J. B. Murdoch & Co., 714 Penn Ave., Pittsburg, Pa.
For page see List of Advertisers.

H. Bayersdorfer & Co., 1129 Arch St., Philadelphia.
For page see List of Advertisers.

Alex. Mann, Jr., Co., 1125 Polk St., San Francisco, Calif.
For page see List of Advertisers.

FLOWERS BY TELEGRAPH

Park Floral Co., Denver, Colo.
For page see List of Advertisers.

J. N. Champion & Co., 1026 Chapel St., New Haven, Conn.
For page see List of Advertisers.

George H. Cooke, Washington, D. C.
For page see List of Advertisers.

Gude Bros. Co., 1214 F St., Washington, D. C.
For page see List of Advertisers.

Atlanta Floral Co., Atlanta, Ga.
For page see List of Advertisers.

P. J. & J. E. Hauswirth, 232 Michigan Ave., Chicago.
For page see List of Advertisers.

William J. Smyth, Michigan Ave. and 31st St., Chicago.
For page see List of Advertisers.

Jacob Schulz, 644 4th Ave., Louisville, Ky.
For page see List of Advertisers.

Thos. F. Galvin, 124 Tremont St., Boston.
For page see List of Advertisers.

Julius A. Zinn, 2 Beacon St., Boston.
For page see List of Advertisers.

Houghton & Clark, 396 Boylston St., Boston.
For page see List of Advertisers.

FLOWERS BY TELEGRAPH—**Continued**

Sidney Hoffman, 50-61 Massachusetts Ave., Boston.
For page see List of Advertisers.

Edward MacMulklin, 194 Boylston St., Boston.
For page see List of Advertisers.

J. Breitmeyer's Sons, Miami and Gratiot Aves., Detroit, Mich.
For page see List of Advertisers.

Samuel Murray, 1017 Broadway, Kansas City, Mo.
For page see List of Advertisers.

Wm. L. Rock Flower Co., 1116 Walnut St., Kansas City, Mo.
For page see List of Advertisers.

Fred C. Weber, 4326-28 Olive St., St. Louis, Mo.
For page see List of Advertisers.

H. G. Eyres, 11 N. Pearl St., Albany, N. Y.
For page see List of Advertisers.

David Clarke's Sons, 2159-2141 Broadway, New York.
For page see List of Advertisers.

W. H. Donohoe, 17 E. 28th St., New York.
For page see List of Advertisers.

Alex. McConnell, New York.
For page see List of Advertisers.

Robert G. Wilson, Fulton St. & Greene Av., Brooklyn, N. Y.
For page see List of Advertisers.

Thomas Young, Jr., 500 Fifth Ave., N. Y.
For page see List of Advertisers.

Young & Nugent, 42 W. 28th St., N. Y.
For page see List of Advertisers.

FLOWER POTS

W. H. Ernest, 28th and M Sts., Washington, D. C.
For page see List of Advertisers.

A. H. Hews & Co., Cambridge, Mass.
For page see List of Advertisers.

Hilfinger Bros., Ft. Edward, N. Y.
For page see List of Advertisers.

Paper pots for all early vegetables. Two inch pots \$1.00 a thousand; three inch \$1.25; four inch \$1.60. P. B. Crosby, Catonsville, Md.

Galax

Michtgau Cut Flower Co., 38 and 40 Broadway, Detroit, Mich.
For page see List of Advertisers.

Fluets green and bronze Galax in any quantity at lowest figures. N. F. McCarthy, 84 Hawley St., Boston.
For page see List of Advertisers.

GERANIUMS

R. Vincent Jr. & Sons Co., White Marsh, Md.
New and Standard Varieties.
For page see List of Advertisers.

GLADIOLI

Arthur Cowee, Meadowvale Farm, Berlin, New York.
For page see List of Advertisers.

J. L. Moore, Northboro, Mass.
For page see List of Advertisers.

John Lewis Childs, Floral Park, N. Y.
Gladiolus America.
For page see List of Advertisers.

I. & J. L. Leonard, Iona, N. J.
Gladiolus Bulbs.
For page see List of Advertisers.

Gladioli. Write for leaflet. B. Hammond Tracy, Cedar Acres, Wenham, Mass.
Gladioli. Named varieties and mixtures. Send for list. E. E. Stewart, Rives Junction, Mich.

GLASS

Boston Plate & Window Glass Co., Boston
For page see List of Advertisers.

Standard Plate Glass Co., 26-30 Sudbury St., Boston.
For page see List of Advertisers.

Metropolitan Material Co., 1398-1408 Metropolitan Ave., Brooklyn, N. Y.
For page see List of Advertisers.

S. Jacobs & Sons, 1365-79 Flushing Ave., Brooklyn, N. Y.

Foley Mfg. Co., between Western Ave. and 26th St., Chicago, Ill.

GLASS. High Grade. Double Thick Greenhouse Glass. Lord & Burnham, 1133 Broadway, N. Y.

GLAZING POINT

H. A. Dreer, Philadelphia, Pa.
For page see List of Advertisers.

GLAZING POINTS, Lord & Burnham Special Glazing Nails (Points). Lord & Burnham, 1133 Broadway, N. Y.

GREENHOUSE BUILDING MATERIAL.

Lord & Burnham Co.,
1133 Broadway, New York.
For page see List of Advertisers.

Plerion U-Bar Co., 1 Madison Sq., N. Y.
For page see List of Advertisers.

Hitchings & Co., 1170 Broadway, N. Y.
For page see List of Advertisers.

A. T. Stearns Lumber Co., Neponset, Boston.
For page see List of Advertisers.

King Construction Co., N. Tonawanda, New York.
For page see List of Advertisers.

J. C. Moninger Co., 117 East Blackhawk St., Chicago, Ill.
For page see List of Advertisers.

Foley Mfg. Co., between Western Ave. and 26th St., Chicago, Ill.
For page see List of Advertisers.

I. Cassidy, Summer Ave. and Erie R. R., Newark, N. J.
For page see List of Advertisers.

W. H. Lutton, Jersey City, N. J.
For page see List of Advertisers.

Geo. B. Doane, 18 Midway St., Boston.
Iron Pipe.
For page see List of Advertisers.

Metropolitan Material Co., 1398-1408 Metropolitan Ave., Brooklyn, N. Y.
For page see List of Advertisers.

S. Jacobs & Sons, 1365-79 Flushing Ave., Brooklyn, N. Y.

GREENHOUSE CONSTRUCTION

GREENHOUSE CONSTRUCTION, Semi-Iron Greenhouse, New Truss Houses and Iron Frame Houses. Lord & Burnham, 1133 Broadway, N. Y.

J. A. Payne, 260-274 Culver Ave., Jersey City, N. J.
For page see List of Advertisers.

I. Cassidy, Summer Ave. and Erie R. R., Newark, N. J.
For page see List of Advertisers.

Foley Mfg. Co., between Western Ave. and 26th St., Chicago, Ill.

W. H. Lutton, Jersey City, N. J.
For page see List of Advertisers.

GREENHOUSE HOSE

Mineralized Rubber Co., 18 Cliff St., N. Y.
For page see List of Advertisers.

GUTTERS

GUTTERS, Cast Iron Gutters, L. & B. Improved V Shaped Gutter with drip gutter attachment. Lord & Burnham, 1133 Broadway, N. Y.

HAIL INSURANCE

Florists' Hall Asso. of America.
J. G. Esler, Saddle River, N. J.
For page see List of Advertisers.

HARDY FERNS AND SUPPLIES

H. M. Robinson & Co., 15 Province St. and 9 Chapman Pl., Boston, Mass.
For page see List of Advertisers.

The Kervan Co., 112 W. 28th St., N. Y.
For page see List of Advertisers.

Michigan Cut Flower Exchange, 38 and 40 Broadway, Detroit, Mich.
Fancy Ferns.
For page see List of Advertisers.

A full line of ferns, galax, and all wild greens. N. F. McCarthy & Co., 84 Hawley St., Boston.
For page see List of Advertisers.

In writing to Advertisers kindly mention Horticulture

HEATING APPARATUS

Lord & Burnham Co.,
1133 Broadway, New York.
For page see List of Advertisers.

Pierson U-Bar Co., 1 Madison Sq., N. Y.
For page see List of Advertisers.

Hitchings & Co., 1170 Broadway, N. Y.
For page see List of Advertisers.

John A. Payne, 260-274 Culver Ave., Jersey
City, N. J.
For page see List of Advertisers.

HELP FURNISHED

Thos. H. Bambrick, 34 S. 7th St., Phila.
For page see List of Advertisers.

HERBACEOUS PERENNIALS

Red Oak Nurseries, Fiskeville, R. I.
For page see List of Advertisers.

HOT-BED SASH

The A. T. Stearns Lumber Co., Neponset,
Mass.
For page see List of Advertisers.

Pierson U-Bar Co., 1 Madison Sq., N. Y.
For page see List of Advertisers.

Hitchings & Co., 1170 Broadway, N. Y.
For page see List of Advertisers.

Lord & Burnham Co., 1133 Broadway, N. Y.
For page see List of Advertisers.

Foley Mfg. Co., between Western Ave. and
26th St., Chicago, Ill.

INSECTICIDES.

Nicotinide kills all greenhouse pests.
P. R. Palethorpe Co.,
Eleventh St., Owensboro, Ky.

For page see List of Advertisers.

B. G. Pratt Co., 11 Broadway, New York.
For page see List of Advertisers.

JAPANESE CUT FLOWER HOLDER

M. V. Garnsey, 130 Walola Ave.,
La Grange, Ill. Dept. F.
For page see List of Advertisers.

KENTIAS

A. Leuthy & Co., Roslindale, Mass.
For page see List of Advertisers.

Godfrey Aschmann, 1012 W. Ontario St.,
Philadelphia.
For page see List of Advertisers.

LEADING RETAIL FLORISTS

Park Floral Co., Denver, Colo.
For page see List of Advertisers.

George H. Cooke, Washington, D. C.
For page see List of Advertisers.

Gude Bros. Co., 1214 F St.,
Washington, D. C.
For page see List of Advertisers.

Atlanta Floral Co., Atlanta, Ga.
For page see List of Advertisers.

P. J. & J. E. Hauswirth, 232 Michigan Ave.,
Chicago.
For page see List of Advertisers.

William J. Smyth, Michigan Ave. and 31st
St., Chicago.
For page see List of Advertisers.

Jacob Schulz, 644 4th Ave., Louisville, Ky.
For page see List of Advertisers.

Thos. F. Galvin, 124 Tremont St., Boston.
For page see List of Advertisers.

Jullus A. Zinn, 2 Beacon St., Boston.
For page see List of Advertisers.

Houghton & Clark, 396 Boylston St.,
Boston.
For page see List of Advertisers.

Sidney Hoffman, 59-61 Massachusetts Ave.,
Boston.
For page see List of Advertisers.

Edward MacMullin, 194 Boylston St.,
Boston.
For page see List of Advertisers.

J. Breitmeyer's Sons, Detroit, Mich.
For page see List of Advertisers.

Samuel Murray, 1017 Broadway,
Kansas City, Mo.
For page see List of Advertisers.

Wm. L. Rock Flower Co., 1116 Walnut
St., Kansas City, Mo.
For page see List of Advertisers.

LEADING RETAIL FLORISTS —**Continued**

Fred C. Weber, 4326 Olive St., St. Louis
Mo.
For page see List of Advertisers.

J. N. Champion & Co., 1026 Chapel St.,
New Haven, Conn.
For page see List of Advertisers.

H. G. Eyres, 11 N. Pearl St., Albany, N. Y.
For page see List of Advertisers.

David Clarke's Sons, 2139-2141 Broadway,
New York.
For page see List of Advertisers.

W. H. Donohoe, 17 E. 28th St., New York.
For page see List of Advertisers.

Alex. McConnell, New York.
For page see List of Advertisers.

Robert G. Wilson, Fulton St. and Greene
Ave., Brooklyn, N. Y.
For page see List of Advertisers.

Thomas Young, Jr., 500 Fifth Ave., N. Y.
For page see List of Advertisers.

Young & Nugent, 42 W. 28th St., N. Y.
For page see List of Advertisers.

Kansas City, Mo., Alpha Floral Co.

LOBELIAS

Jos. Fuller, 31 Orchard St., Leominster,
Mass.
Carter's Double Blue Lobelia.
For page see List of Advertisers.

NEW AND RARE PLANTS

Rose Hill Nurseries, New Rochelle, N. Y.
For page see List of Advertisers.

NICO-FUME

Kentucky Tobacco Product Co.,
Louisville, Ky.
For page see List of Advertisers.

NURSERY STOCK

John Waterer & Sons, Ltd.,
American Nursery, Bagshot, England.
For page see List of Advertisers.

New England Nurseries, Bedford, Mass.
Shrubs, Roses and Herbaceous Perennials.
Specimen Pyramidal Box.
For page see List of Advertisers.

Bay State Nurseries, N. Abington, Mass.
Herbaceous Perennials, Hardy Ornamental
Trees.
For page see List of Advertisers.

Clery's Horticultural Co., 62 Vesey St.,
New York.
For page see List of Advertisers.

P. Ouwkerk, 216 Jane St., Weehawken
Heights, N. J.
Holland Nursery Stock for Foreign.
For page see List of Advertisers.

American Nursery Co., 150 Broadway, New
York, N. Y.
For page see List of Advertisers.

Pierce Nurseries, Beverly Farms, Mass.
Tree Seedlings and Rooted Cuttings.
For page see List of Advertisers.

I. & J. L. Leonard, Iona, N. J.
California Privet, American Chestnuts.
For page see List of Advertisers.

Nursery Stock, N. F. McCarthy & Co.,
84 Hawley St., Boston, Mass.

ORCHID PLANTS

Lager & Hurrell, Summit, N. J.
For page see List of Advertisers.

Sander, St. Albans, England.
Importers, Exporters, Growers, Hybridists
For page see List of Advertisers.

Jullus Roehrs Co., Rutherford, N. J.
For page see List of Advertisers.

Carrillo & Baldwin, Secaucus, N. J.
For page see List of Advertisers.

Jos. A. Manda, 191 Valley Road, W.
Orange, N. J.
For page see List of Advertisers.

Ordenez Bros., Madison, N. J., Box 106
For page see List of Advertisers.

PALMS

A. Leuthy & Co., Perkins St. Nurseries,
Roslindale, Mass.
For page see List of Advertisers.

Robert Craig Co., Market and 49th Sts.,
Philadelphia, Pa.
For page see List of Advertisers.

John Lewis Childs, Floral Park, N. Y.
Phoenix Roebelin.
For page see List of Advertisers.

Kentia, Phoenix, etc., all sizes. Write
for new price list. Jullus Roehrs Co.,
Rutherford, N. J.

PAINT AND PUTTY

PAINT AND PUTTY: Ideal Greenhouse
lead; Special Greenhouse Putty. Lord &
Burnham, 1133 Broadway, N. Y.

PANSY PLANTS.

Choice pansy plants, 50c. per 100; \$4.00
per 1000. Cash. Aug. Zirniglebel, Need-
ham, Mass.

PATENTS

Siggers & Siggers, Washington, D. C.
For page see List of Advertisers.

PEAT

Orchid peat, Rotted peat, Azalea peat,
Leaf-Mould, Live Sphagnum moss, Baled
Sphagnum moss, Green Clump moss, etc.
Jobbers' list on application. C. W. Brown-
ell & Co., Walden, N. Y.

PELARGONIUMS

R. Vincent, Jr. & Sons Co., White Marsh,
Maryland.
For page see List of Advertisers.

PEONIES

One of the finest collections in America.
Send 25 cts. in stamps for new edition of
Peony Manual. C. S. Harrison's Select
Nursery, York, Neb.

PETUNIAS

Del. Petunias, 8 best market sorts,
named, including a fair proportion of our
new "Camellia-bora," the best white
grown, needs no staking; well rooted,
\$1.25 per 100 prepaid, \$10.00 per 1000;
2-in short, stocky, \$2.50 per 100. Hopkins
& Hopkins, Chepachet, R. I.

PHLOXES

Send 25 cts. in stamps for Phlox Manual.
Fine mixed phloxes \$1.50 per 100. C. S.
Harrison's Select Nursery, York, Neb.

PIPE AND FITTINGS

Foley Mfg. Co., between Western Ave. and
26th St., Chicago, Ill.

PIPE AND FITTINGS. Cast iron and
Wrought Pipe, Valves, Elbows, Pipe Hooks,
Automatic Air Headers, etc. Lord &
Burnham, 1133 Broadway, N. Y.

PLANT BED CLOTH

Mineralized Rubber Co., 18 Cliff St., N. Y.
For page see List of Advertisers.

POT HANGERS

Pot hangers, Kramer's \$1 doz. by exp.,
\$1.25 by mail. I. N. Kramer & Son, Cedar
Rapids, Ia.

PRUNING SHEARS

Rhodes Mfg. Co., Grand Rapids, Mich.
Dept. R.

RAFFIA

Raffia (colored), 20 beautiful shades.
Samples free. R. M. Comey Co., Camden,
N. J.; 810 Washburn Ave., Chicago, Ill.

RHODODENDRONS

John Waterer & Sons, Ltd.,
American Nursery, Bagshot, England.
For page see List of Advertisers.

ROSES

Jullus Roehrs Co., Rutherford, N. J.
Rambler Rose, Newport Fairy.
For page see List of Advertisers.

New England Nurseries, Inc., Bedford,
Mass.

Roses for Forcing.
For page see List of Advertisers.

For List of Advertisers See Page 284

ROSES—Continued

Bay State Nurseries, N. Abington, Mass.
Roses for Foreign.
For page see List of Advertisers.

Ellwanger & Barry, Rochester, N. Y.
Hardy Roses.
For page see List of Advertisers.

John Cook, 318 Charles St., N. Baltimore,
Maryland.
Rose My Maryland.
For page see List of Advertisers.

Robert Craig Co., Market and 49th Sts.,
Philadelphia, Pa.
For page see List of Advertisers.

A. N. Pierson, Cromwell, Conn.
Grafted and Own Root Roses.

400 varieties; own roots; summer grown.
Leedie Company, Springfield, Ohio.

Crimson Ramblers, 2 year, on own roots,
extra strong, at 7 cents. Gilbert Costich,
Rochester, N. Y.

Low-budded roses, No. 1, \$95.00; No.
11-2, \$65.00 1000. H. T. Jones, Elizabeth,
N. J.

SCALECIDE

B. G. Pratt Co., 11 Broadway, New York.
For page see List of Advertisers.

SEEDS

T. J. Grey Co., 32 So. Market St.,
Boston, Mass.
For page see List of Advertisers.

Joseph Breck & Sons,
51 and 52 N. Market St., Boston, Mass.
For page see List of Advertisers.

W. Atlee Burpee & Co., Philadelphia.
For page see List of Advertisers.

J. M. Thorburn & Co., 33 Barclay St., N. Y.
For page see List of Advertisers.

A. T. Boddington, 342 W. 14th St., N. Y.
For page see List of Advertisers.

H. F. Michell Co., 1017 Market St., Phila.
For page see List of Advertisers.

James Vick's Sons, Rochester, N. Y.
Vick's Superb Pansy Seed.
For page see List of Advertisers.

Hjalmar Hartmann & Co.,
12 Stormgade, Copenhagen, Denmark.
Cauliflower and Cabbage Seed.
For page see List of Advertisers.

Rickards Bros., 37 E. 19th St., New York.
For page see List of Advertisers.

R. & J. Farquhar & Co., 6-7 So. Market
St., Boston.
Giant Cyclamen Seed.
For page see List of Advertisers.

C. C. Morse & Co., 48-56 Jackson St.,
San Francisco, Cal.
For page see List of Advertisers.

H. E. Fiske Seed Co., Faneuil Hall Sq.,
Boston.
For page see List of Advertisers.

Branlan Seed Growers Co., San Jose Cal.
For page see List of Advertisers.

O. V. Zangen, Hoboken, N. J.
For page see List of Advertisers.

R. Wilholt, Nakskov, Denmark.
Snowball Cauliflower Seed.
For page see List of Advertisers.

Wm. Elliott & Sons, 201 Fulton St.,
New York.
Lincoln Pansy Seed.
For page see List of Advertisers.

Saender & Son, Bruges, Belgium.
Cocos Weddelliana Seed.

Stump & Walter Co., 50 Barclay St.,
New York.
Flower Seeds New Crop.
For page see List of Advertisers.

Schlegel & Fottler Co., 26 & 28 So. Market
St., Boston.

Cyclamens, Asparagus and Summer Flow-
ering Bulbs and Roots.
For page see List of Advertisers.

Crego aster seed. Ask for circular. G.
S. Crego, Maywood, Ill.

SMILAX

E. A. Beaven, Evergreen, Ala.
Southern Wild Smilax; Log Mosses.
For page see List of Advertisers.

SPHAGNUM MOSS

Live Sphagnum moss, orchid pent and
orchid baskets always on hand. Lager &
Hurrell, Summit, N. J.

Fresh, clean, 5 bbl. bale, \$1.25; 2 bales,
\$2.25; 5 bales, \$5.00; 10 bales, \$9.50. Cash.
H. R. Akers, Chatsworth, N. J.

STEAM TRAP

E. Hippard, Youngstown, O.
For page see List of Advertisers.

VEGETABLE PLANTS

A few millions Frost Proof Cabbage
Plants of all the best varieties at \$1.25
per 1,000; \$1 per 1,000 above 5,000. Ex-
press at Charleston, S. C. Special price
for large lots. Rates on plants very low.
Alfred Jouannet, Mt. Pleasant, S. C.

VENTILATING APPARATUS

Pierson U-Bar Co., 1 Madison Sq., N. Y.
For page see List of Advertisers.

Hitchings & Co., 1170 Broadway, N. Y.
For page see List of Advertisers.

Foley Mfg. Co., between Western Ave. and
26th St., Chicago, Ill.
For page see List of Advertisers.

John A. Payne, 260-274 Culver Ave., Jersey
City, N. J.
For page see List of Advertisers.

VENTILATING MACHINERY. New
Model encased, self-oiling gear; Standard
Model Open Gear. Lord & Burham, 1133
Broadway, N. Y.

VIOLETS

William Sim, Cliftondale, Mass.
Violet Boston.
For page see List of Advertisers.

Violet cuttings, "Marla Louisa" Rhine-
beck stock, rooted runners, May delivery
\$20.00 M. Immediate delivery, between
now and March 15th, \$10.00 M. Wm. F.
Kasting Co., 383 Ellicott St., Buffalo, N. Y.

WIREWORK

Reed & Keller, 122 W. 23th St., N. Y.
For page see List of Advertisers.

Wirework. Write for our catalogue.
Holton & Hunkel Co., Milwaukee, Wis.

William E. Heilscher's Wire Works, 38-40
Broadway, Detroit, Mich.

The "Just Right" kind. Send for price
list. Frank W. Ball, 31 East Third Street,
Cincinnati, O.

WHOLESALE FLORISTS

Boston

N. F. McCarthy & Co., 84 Hawley St.,
Boston.
For page see List of Advertisers.

H. M. Robinson & Co., 15 Province St.
and 9 Chapman Pl., Boston.
For page see List of Advertisers.

Welch Bros., 226 Devonshire St., Boston.
For page see List of Advertisers.

Buffalo

Wm. F. Kasting Co., 383-87 Ellicott St.,
Buffalo, N. Y.
For page see List of Advertisers.

Chicago

Chas. W. McKellar, 51 Wabash Ave.,
Chicago.
For page see List of Advertisers.

Peter Reinberg, 51 Wabash Ave., Chicago.
For page see List of Advertisers.

E. F. Winterson Co., 45-49 Wabash Ave.,
Chicago.
For page see List of Advertisers.

Detroit

Michigan Cut Flower Exchange, 38 and 40
Broadway, Detroit, Mich.
For page see List of Advertisers.

WHOLESALE FLORISTS—

Continued

New York

J. K. Allen, 106 W. 25th St., New York.
For page see List of Advertisers.

J. S. Fenrich, 110 W. 28th St., New York.
For page see List of Advertisers.

Ford Bros., 48 W. 28th St., New York.
For page see List of Advertisers.

H. E. Froment, 57 W. 28th St., New York.
For page see List of Advertisers.

Alex. J. Guttman, 43 W. 28th St., New
York.
For page see List of Advertisers.

E. C. Horan, 55 W. 28th St., New York.
For page see List of Advertisers.

A. H. Langjahr, 55 W. 28th St., New York.
For page see List of Advertisers.

James McManus, 42 W. 28th St., New York.
For page see List of Advertisers.

John I. Raynor, 49 W. 28th St., New York.
For page see List of Advertisers.

W. F. Sheridan, 39 W. 28th St., New York.
For page see List of Advertisers.

Traendly & Schenck, 44 W. 28th St., New
York.
For page see List of Advertisers.

John Young, 51 W. 28th St., New York.
For page see List of Advertisers.

Moore, Heintz & Nash, 55 and 57 W. 26th
St., New York.
For page see List of Advertisers.

Frank S. Hicks & Co., 52 W. 26th St.,
New York.
For page see List of Advertisers.

Frank Mullang, 57 W. 26th St., New York.
For page see List of Advertisers.

Wm. H. Kuebler, 28 Willoughby St.,
Brooklyn, N. Y.
For page see List of Advertisers.

Philp F. Kessler, 55 and 57 W. 26th St.,
New York.
For page see List of Advertisers.

A. Moltz, 55-57 W. 26th St., New York.

B. S. Silan, Jr., 55 W. 26th St., New York.
For page see List of Advertisers.

Philadelphia

W. E. McKissick, 1619-1621 Raostead St.,
Philadelphia, Pa.
For page see List of Advertisers.

Leo Niessen Co., 1309 Arch St., Philadel-
phia, Pa.
For page see List of Advertisers.

The S. S. Pennock-Meehan Co., 1608-18
Ludlow St., Philadelphia, Pa.
For page see List of Advertisers.

Edward Reid, 1526 Raostead St., Phila-
delphia, Pa.
For page see List of Advertisers.

Pittsburg

J. B. Murdoch & Co., 714 Peon Ave., Pitts-
burgh, Pa.
For page see List of Advertisers.

Providence, R. I.

J. Kopelman & Co., 21 Washington St.,
Providence, R. I.
For page see List of Advertisers.

San Francisco

Alex. Maun, Jr., Co., 1125 Polk St., San
Francisco, Cal.
For page see List of Advertisers.

St. Louis

H. G. Bering, 1402 Pine St., St. Louis, Mo.
For page see List of Advertisers.

Washington, D. C.

J. J. Harty & Co., 1312 G. St. N. W.,
Washington, D. C.
For page see List of Advertisers.

WHOLESALE PLANTSMAN

Samuel A. Woodrow, 53 W. 30th St.,
New York.
For page see List of Advertisers.

In writing to Advertisers kindly mention Horticulture

List of Advertisers

Table listing advertisers and their page numbers. Includes entries like 'Allen J. K.', 'Altimo Culture Co.', 'American Nursery', etc.

New Offers in This Issue.

- ASTER SEED. Altimo Culture Co., Canfield, O. For page see List of Advertisers. BASKETS FOR FLORISTS: BERRY BASKETS: FRUIT PACKAGES. Coles & Co., 100 & 111 Warren St., New York. For page see List of Advertisers. CANNAS. A. T. Boddington, 342 W. 14th St., New York. For page see List of Advertisers. FRENCH BULBS. Ralph M. Ward & Co., 12 W. Broadway, New York, Agts. for Martial Bromond, Ollioules, France. For page see List of Advertisers. HARDY TREES, SHRUBS, PERENNIALS. Eastern Nurseries (M. M. Dawson, Mgr.), Jamaica Plain, Mass. For page see List of Advertisers. HOT-BED MATS. G. H. Frost, W. Newton, Mass. For page see List of Advertisers. NEW CLIMBING ROSE, TAUSEND-SCHON. Dingee-Conard Co., West Grove, Pa. For page see List of Advertisers. NOVELTY CHRYSANTHEMUMS. Elmer D. Smith & Co., Adrian, Mich. For page see List of Advertisers. SECOND-HAND PIPE AND BOILER TUBES. Eagle Metal & Supply Co., Johnson and Union Aves., Brooklyn, N. Y. For page see List of Advertisers. TOBACCO STEMS. Wm. Elliott & Sons, 201 Fulton St., New York. For page see List of Advertisers. TREES AND PLANTS. D. J. Twomey, Dept. H., Geneva, N. Y. For page see List of Advertisers. SHAMROCKS. John F. Rupp, Shiremanstown, Pa. For page see List of Advertisers. SHAMROCKS: GREEN CARNATION COLORING: GREEN 6-PLY FLORISTS' TWINE. N. E. McCarthy & Co., 84 Hawley St., Boston. For page see List of Advertisers. WHOLESALE FLORISTS. Millang Bros., 41 W. 28th St., New York. For page see List of Advertisers. FOR SALE Greenhouse property consisting of five houses, two each 300x16, one 150x16, one 200x10, one 200x15, 125 feet connecting sheds. Heated by two 40 horse power, high pressure boilers. Small engine for operating blower, City water. Dwelling-house five rooms and barn. Eight acres of land. Place has been built five or six years. Located five minutes from electric cars, twenty minutes' ride to a city of 40,000 population and about twenty miles from Boston. This affords an exceptionally good chance for anyone desiring to go into the growing of flowers for wholesale, also for a very extensive retail business later on. Possession given any time after July 1st. Place can be bought very reasonable, one-half payment cash, balance on mortgage. For further particulars apply to P. WELCH Care of WELCH BROS., 226 Devonshire St., Boston

WANTS, FOR SALE, ETC. Advertisements in this column one cent a word. Initials count as words. Cash with order. All correspondence addressed "care HORTICULTURE" should be sent to 11 Hamilton Place, Boston.

HELP WANTED WANTED — SALESMAN To Handle Good Side Line On Commission One who calls on Florists, Seed Houses, Nurseries, Cemetery Superintendents, Monument Dealers, etc. The Kramer Bros. Foundry Co. DAYTON, OHIO

SITUATIONS WANTED GOOD MEN When you need good men, skilled or unskilled, write: THOS. H. BAMBRICK 34 South 7th Street Philadelphia Help of all kinds, including that for Florists, Nurserymen, Seedsmen and the Horticultural trade generally.

SITUATION WANTED in general greenhouse work; single, age 35, five years' experience, commercial. Address W. W., care HORTICULTURE.

FOR SALE FOR SALE Greenhouse Plant, consisting of three houses, one 142x32, one 75x18 and one 15x10, with cold frames and sash; boiler and potting house 20x20 and every convenience for commercial business. These houses were built three years ago by Lord & Burnham Co. and are strictly up-to-date in every particular. Two Burnham steam boilers, one of which heats entire plant. In construction every point was considered with view of enlarging. Present steam capacity sufficient for double the size of plant. Fully stocked with finest crop of carnations, etc., and in perfect running order. In centre of population of upward of 200,000 within radius of ten miles. First-class electric car service (two lines) and steam R. R. connecting with B. & A. R. R., Boston, Worcester and surrounding towns. Excellent opportunity for large retail trade. This property includes dwelling of 8 rooms and 2 1/2 acres of land. Owners are engaged in other lines of business and will sell at a low price. Inquire of B., care HORTICULTURE.

HOT-BED MATS STRAW, 6c, little used 75c to \$1.00 G. H. FROST, West Newton, Mass. FOR SALE OR TO LET—15 acres of land, nearly all under cultivation; 20,000 sq. ft. glass, house well stocked with carnations, chrysanthemums, etc.; 8-room dwelling house, steam heated; large barn; in a city of 14,000 population, 10 miles from Boston; excellent transportation facilities. Good retail trade now established. Terms will be made satisfactory. Possession given April 1 or sooner if desired. Address A. G., care HORTICULTURE.

FOR SALE—A large consignment of 16x24 double thick American glass, A and B quality. For further information write Parshelsky Brothers, 59 Montrose Avenue, Brooklyn, N. Y.

Is Your Name In The Above List? . If Not, Why Not?

WANTED. To buy, to lease with the right to buy, or to lease, several Greenhouses with ground where retailing and landscaping is possible. Address L. E., care of HORTICULTURE.

Tobacco Paper

IS THE

**STRONGEST,
BEST PACKED,
EASIEST APPLIED.**

24 sheets.....	\$ 0.75
144 sheets.....	3.50
288 sheets.....	6.50
1728 sheets.....	35.10

“NICO-FUME”

LIQUID

OVER 40% NICOTINE

By far the
CHEAPEST.

**Furnishes the
Most Nicotine for the Money!**

JUST NOTE PRICES!

Pint.....	\$ 1.50
½ Gallon.....	5.50
Gallon.....	10.50
5 Gallons.....	47.25

... Manufactured by ...
THE KENTUCKY TOBACCO PRODUCT CO., **Louisville, Ky.**

SMALL FRUITS.

A paper read before the Vermont Horticultural Society by Wilfrid Wheeler.

In taking a view of the fruit situation of the country in general, one is apt to underestimate the value of the small fruit crop, giving prominence to the apple and orange crop, putting them down as more important contributions to the fruit industry—statistics, however, show us that the strawberry alone is grown in as large quantities as the apple, and forms throughout a shorter season, as necessary an adjunct to the fruit consuming public as any other fruit produced.

The Situation in New England.

From a commercial standpoint as yet in New England small fruits have not attained as much importance as they deserve. The strawberry is perhaps an exception to this rule, particularly in the vicinity of our large cities, where it is grown chiefly to supply the local market, but even then the amount of this fruit grown is small when compared with the South and the West, where thousands of acres are devoted to strawberries which are grown and shipped to markets from 500 to 3000 miles away. This shows what quick transportation has done for a crop which forty years ago was produced in the home garden.

At present the people of New England grow about one-half the small fruit that is needed for their consumption, leaving the balance to be supplied from other states. This lack of small fruits is particularly noticeable in the rural districts, where many of the farmers are engaged in dairying and do not consider it necessary to provide their families with the fruits which are so delicious to eat and so easily grown. Then, too, in those outlying parts of the country there is a large amount of wild fruit, such as blueberries, raspberries and blackberries, which can be had for the picking and which to a certain extent fill the place of the cultivated fruits, but to my mind these are only poor substitutes for the home grown article which can be gathered at your back door, and which excels in quality and flavor the uncultivated varieties.

Quick Returns.

Few people realize that the strawberry, also the currant and gooseberry, can be successfully grown among young apple and pear orchards, thus insuring a quicker return from the land than by waiting from seven to ten years for the larger fruits to bear. Study your conditions and if

you are growing fruit at all see if you cannot get in some of these small fruits and help out your income as well as furnish you with an occupation a part of the year when the general work of an orchard is more or less slack.

Small fruits come at a season when they are particularly needed and wished for, and should on that account be welcomed and appreciated, and the growing of them should appeal to those who are interested in fruit culture, not only from an economical standpoint, but also from what might be termed the home garden point of view. Here in Vermont where you have a large summer population the question of supplying it with fresh fruit ought not to be a difficult one to solve, when you have the strawberry bed, the blackberry and raspberry patch, and the currant and gooseberry bushes to depend on.

It is often the cases in country towns and especially those near small cities, that the few berries that are raised are sent away and the unlucky householder who has failed to supply his own needs from his garden finds it impossible to buy any fruit near home.

Yet these people from the city are willing to pay well for something they can't get at home, but with which you can supply them right here on your own farms, namely, fine, fresh fruit. Then, too, where many of the farmers drive every day to railroad stations and large towns with their milk, butter and eggs, it would be a source of additional income to add a few boxes of choice berries to the load and either take them to the local market or deliver them to the householders of the town, for your small city is often supplied from fruit sent from Boston, which when it arrives is hardly fit for use and could not in any way compare with the native crop.

Easy of Culture.

When you consider that these small fruits, the strawberry, raspberry, blackberry, currant and gooseberry can be grown to perfection on almost any soil and with almost any exposure, can be made a profitable as well as a pleasant occupation, aside from the other work of the farm, there will really be no excuse for not planting them to the extent of your ability to care for and your market to handle such crops.

We need more home fruit gardens in New England, and especially gardens where the healthy, pleasant and profitable occupation of small fruit-growing for commercial purposes is undertaken. Then we would not see our markets

filled with the products of other states and the money which might be ours going in other directions, not infrequently out of the country altogether.

One other important need in connection with small fruit growing and that is more men, more young, efficient, well qualified men to take up this important branch of horticulture, to take it up in a sensible, thoughtful, scientific way, realizing, of course, that there are drawbacks and disadvantages as there are along any line of work, but determining at the same time to make a success of small fruit growing in New England.

The Outlook for the industry.

The outlook for this industry was never more encouraging than at present. With a developing country, a shifting population, a grand exodus of the people from the city to the country during the summer and above all with a largely increased appetite among all the people for small fruits, there is a demand for greater efforts on the part of the horticulturist of the country. Then again new uses are always being found for these fruits, they are now used in so many forms of preserves, in medicines, and since the pure food acts their juices are actually being found on the soda water fountains.

A very important point which ought to have the consideration of New England fruit growers is the shipping of our surplus small fruit crop to some of the southern cities. Some years the larger northern cities are overcrowded with strawberries, while some of the southern markets are unsupplied and would gladly welcome the fruit which is being sold at home at a loss. You ship a perishable article like milk great distances; why not try the experiment with small fruits?

About the Strawberry.

Of the strawberry, the most important of this group of small fruits, I wish to speak somewhat at length. Its ease of cultivation, its great adaptability to soil and climate, the quick returns it gives, the beauty and quality of its fruit, all combine to make it the most popular fruit in the world. There is probably no climate between the north and south temperate zones that the strawberry will not grow in and we find it under such varying conditions in the hundred acre field and in the city back yard, growing and flourishing and producing its wealth of crimson fruit for the joy and refreshment of mankind. In spite of the ease with which the strawberry grows, there are a few general directions which should not be forgotten when

"SCALECIDE"

HAS MADE SPRAYING EASY THEN WHY NEGLECT YOUR TREES?

The N. Y. Herald, November 17, '07, says: "The chances are about a hundred to one that you have the San Jose Scale on your place and do not know it," and advises the use of "SCALECIDE." This is good advice. "SCALECIDE" has been tested and tried, and found thoroughly effective. The same yesterday, to-day, and all the time. One gallon makes 15 to 20, ready to use, by simply adding water.

Prices: 1 gal., \$1.00; 5 gal., \$3.25; 10 gal., 6.00; 50 gal. bbl., \$25.00, F. O. B. our factory. Order to-day. Write for booklet W and free sample.

**B. G. PRATT CO., Mfg. Chemists,
11 Broadway, New York City.**

THE STANDARD STEAM TRAP

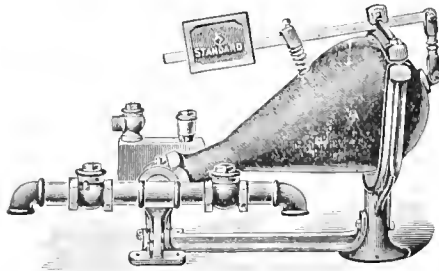

is acknowledged the best for the florist, because it is durable and does its work without trouble and annoyance, saving its cost by the economy in coal bills.

**E. HIPPARD
YOUNGSTOWN, OHIO**

successful strawberry culture is the desired end, and first,—the situation for a strawberry bed should be protected from sweeping winds and also from the burning hot sun of a southern hillside. Then the soil must not be too wet or too dry, and the plants when set should be thoroughly cultivated, weeded and protected in winter.

If possible, choose the land for a strawberry bed with a slight slope, enough to drain off surface water, but yet not so steep that the soil will wash during heavy rains. If you have no choice and must use flat land, see that there are no low places where water will stand and cover the plants in winter. If the land chosen is too wet, and by "too wet" I mean that the ground water is nearer than one foot from the surface, it must be drained the same way; a convenient method is with tiles or stone drains. Dry land can be improved by the addition of macadam mud and plenty of manure, but better results will follow from the choice of the moist land, for during the fruiting season moisture is needed to fill out the berries and bring them to perfection. A safe rule to follow is that land that will grow good corn can be relied upon for strawberries.

(To be Continued)

USEFUL BOOKS.

We can supply the following books, postpaid, at the prices listed:—

- The Chrysanthemum. Herrington Price, 50 cts.
- How to Make Money Growing Violets. Saltford. Price, 25 cts.
- Daffodils-Narcissus and How to Grow Them. A. M. Kirby. Price, \$1.10.
- Commercial Violet Culture. Dr. B. T. Galloway. Price, \$1.50.
- Water Gardening. Peter Bisset Price, \$2.50.
- Lawns and How to Make Them. Leonard Barron. Price, \$1.10.
- Roses and How to Grow Them. By Many Experts. Price, \$1.10.
- The New Encyclopedia of American Horticulture. L. H. Bailey. Four volumes; \$20.00.
- How to Make School Gardens. H. D. Hemenway. Price, \$1.10.



**The Best
Bug Killer and
Bloom Saver**

For PROOF
Write to

**P. R. Palethorpe Co.
OWENSBORO, KY.**

Standard Flower . . . POTS

If your greenhouses are within 500 miles of the Capitol, write us, we can save you money
**W. H. ERNEST,
28th and M Street WASHINGTON D. C.**



**Cattle Manure
In Bags** Shredded or Pulverized

Best and safest manure for florists and greenhouse use, absolutely pure, no waste, no danger. Write for circulars and prices.

The Pulverized Manure Co.,
31 Union Stock Yards, Chicago

BOSTON PLATE & WINDOW GLASS CO.

GREENHOUSE GLASS

German and American

261 to 287 A St., BOSTON 20-22 Canal St.

**The FLORISTS' HAIL ASSOCIATION
OF AMERICA, insurer of 28,000,000
sq. ft. of glass. For particulars address
John C. Esler, Sec'y, Saddle River, N. J.**

- How to Make A Fruit Garden. S. W. Fletcher. Price, \$2.20.
- How to Plan the Home Grounds. S. Parsons, Jr. Price, \$1.10.
- Soils: How to Handle and Improve Them. S. W. Fletcher. Price, \$2.20.

**JOHN A. PAYNE
GREENHOUSE
Designer & Builder**

260-274 Culver Ave.
JERSEY CITY, N. J.



**IRON FRAME
SEMI-IRON FRAME
TRUSS ROOF
WOOD FRAME**
Material Only or Erected
Everything for the Greenhouse

IRON PIPE

SECOND HAND

WROUGHT IRON PIPE, for Steam, Water, Gas or Oil, Fences or Posts. All Sizes. Price Low.

**GEO. B. DOANE & SON
18 Midway Street, BOSTON
Telephone, Main 4419**

SECOND HAND PIPE & BOILER TUBES

Of all sizes, in good condition, suitable for steam purpose, coupled and threaded, for sale at low rates.
5000 feet 1 inch pipe, 3c. per ft.; 5000 feet 1 1/4 inch pipe, 4c. per ft.; 3000 feet 1 1/2 inch pipe, 5c. per ft.; 2000 feet 2 inch pipe, 6 1/2c. per ft.

**EAGLE METAL & SUPPLY CO.,
Johnson and Union Aves., BROOKLYN, N. Y.**



STANDARD FLOWER POTS

Packed in small crates, easy to handle.

Price per crate		Price per crate	
1500 2 1/2 in. pots in crate	\$4.88	120 7 in. pots in crate	\$4.20
1500 3 1/4 " " "	5.25	60 8 " " "	3.00
1500 4 1/4 " " "	6.00	HAND MADE	
1000 3 " " "	5.00	48 9 in. pots in crate	\$3.60
800 3 1/2 " " "	5.80	48 10 " " "	4.80
500 4 " " "	4.50	24 11 " " "	3.60
320 5 " " "	4.50	24 12 " " "	4.80
144 6 " " "	3.16	12 14 " " "	4.80
		6 16 " " "	4.50

Seed pans, same price as pots. Send for price list of Cylinders for Cut flowers, Hanging Baskets, Lawn Vases, etc. Ten per cent. off for cash with order. Address **Hilfinger Bros., Pottery, Fort Edward, N. Y.** August Rolker & Sons, Agts., 31 Barclay St., N. Y. City.

WILLIAM H. LUTTON

HORTICULTURAL ARCHITECT AND BUILDER

WEST SIDE AVENUE STATION (C. R. R. OF N. J.)
JERSEY CITY, N. J.

Have not been established 50 years, but long enough to convince the wide-awake Florist and Gardener that it is to his interest to place his work in thoroughly practical hands.

(150,000 sq. ft glass erected in 1907 will substantiate this claim)

And why not? My material is the best that can be secured. My iron frame construction has every modern feature that years of practical experience can embody.

AND THEN THERE IS THE COST TO BE CONSIDERED.

Why not let us take up this important question now?

GREENHOUSE GLASS

Cheaper Now Than For Years

We are taking contracts for next Spring delivery.

WRITE FOR OUR PRICES

STANDARD PLATE GLASS COMPANY

26-30 Sudbury St. 61-63 Portland St.
 BOSTON, MASS.

CYPRESS SASH BARS
 82 feet or longer
HOT BED SASH
PECKY CYPRESS BENCH LUMBER

GREENHOUSES

ERECTED AND EQUIPPED COMPLETE IF DESIRED

Write for Circular "D" and Prices

The A. T. STEARNS LUMBER CO.
 NEPONSET, BOSTON, MASS.

METROPOLITAN MATERIAL CO.
 GREENHOUSE WRECKERS

GLASS Look at these prices. New American 50 ft. to the box, 10x12 single \$1.80 per box, 10x12, 12x12 B. double \$2.30 per box, 12x14, 12x20 and 14x14, 14x20 and 16x16, 16x18 B. double \$2.50 per box, 16x20, 16x24, 12x24 B. double \$2.65 per box. In lots of 10 boxes or more. Discount on large quantities. Let us quote you on

CYPRESS MATERIAL HOTBED SASH BOILERS PIPE FITTINGS HOTBED FRAMES MATS

1398-1408 METROPOLITAN AV., BROOKLYN, N. Y.

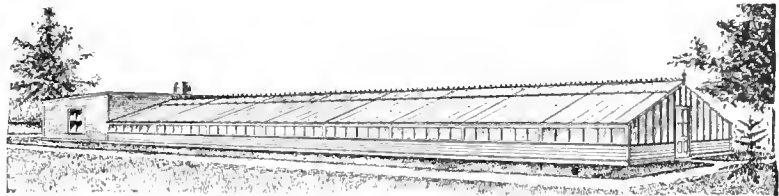

GREENHOUSE MATERIAL

Furnished and Erected. Write for Prices

I. CASSIDY, SUMMER AVENUE AND ERIE R. R. **Newark, N. J.**

NOW IS THE RIGHT TIME TO FIGURE

MATERIAL

AND PLAN FOR THE BUILDINGS OF THIS YEAR

FOLEY'S

QUALITY AND WORK THE BEST. PRICES RIGHT AND LOWEST. ESTIMATES WILL PROVE. TRY US.

Foley Ventilating Apparatus Unequaled

Will ventilate any size of house easily. Send for circular.

THE FOLEY MFG. CO. Western Ave. 25th & 26th Sts. **CHICAGO**

ANCHOR GREENHOUSE HOSE

WEARS WELL.

PLANT BED CLOTH

Protects from Cold and Dampness.

MINERALIZED RUBBER CO.

18 Cliff Street New York

GREENHOUSE CONSTRUCTION LUMBER

John C. Moninger Co.
 117 E. Blackhawk St., CHICAGO

R. TORAWANDA, N. Y.



PATENTS

Trademarks and Copyrights

Send your business direct to Washington. Saves time and insures better service. Personal attention guaranteed. Twenty-five years' active service. SPECIALTY: "Working on the Failures of Others."

SIGGERS & SIGGERS

PATENT LAWYERS

Box 9, National Union Building
 Washington, D. C.

Holds Glass Firmly

See the Point

PEERLESS

winning Points are the best 40 rights or lefts - Box of 1,000 points 75 cts. postpaid.

HENRY A. DEERE,

114 Chestnut St., Philadelphia, Pa.

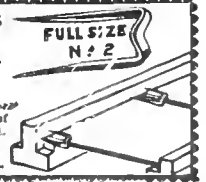

In ordering goods please add, "I saw it in HORTICULTURE"

H AND C

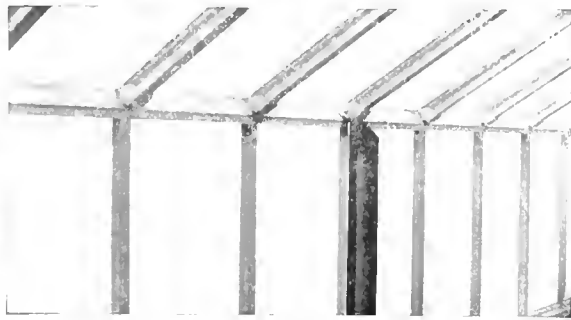

IF YOU WOULD USE OUR
Steel Eave Plate
 With Roof Bar Brackets Attached

Your Eaves would last three
 times as long, and your
GREENHOUSE
 be many times lighter.

HITCHINGS & CO.

1170 Broadway
 NEW YORK

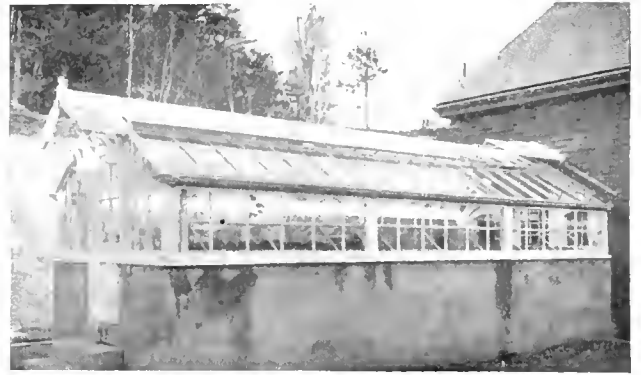

\$300.00

Buys the Materials for the super-
 structure and ventilating appara-
 tus in this 10x25 ft. GREENHOUSE

WRITE FOR PARTICULARS

WE MAKE EVERY PART OF A GREENHOUSE
 BUT THE GLASS. WE SELL ANY PART.

LORD & BURNHAM CO.

1133 BROADWAY, cor. 26th Street, N. Y.
 BOSTON Branch: 819 Tremont Building
 PHILADELPHIA Branch: 1215 Filbert St.



Why U-Bar Greenhouses Excel

Then there is the downright practical side of U Bar houses, the side that means more flowers, or vegetables of finer quality with less care and expense than in any other houses constructed any other way. The reason for this is, in short — *more light*. You see there is no gutter at the eave — no heavy members — the glass is spaced 24 inches instead of 16 inches. Every structural detail has been reduced to the smallest possible point. Still with all this extreme lightness of construction, there is not a more rigid, enduring house made — and it is the U-Bar that does it. The catalog although filled with U-Bar houses, both exteriors and interiors, also shows plans, sections and all the interesting structural details that you like so well to know — Send for it



U=BAR GREENHOUSES

PIERSON U=BAR CO.

Designers and Builders

1 Madison Ave., New York

HORTICULTURE

Vol. VII. MARCH 7, 1908 No. 10

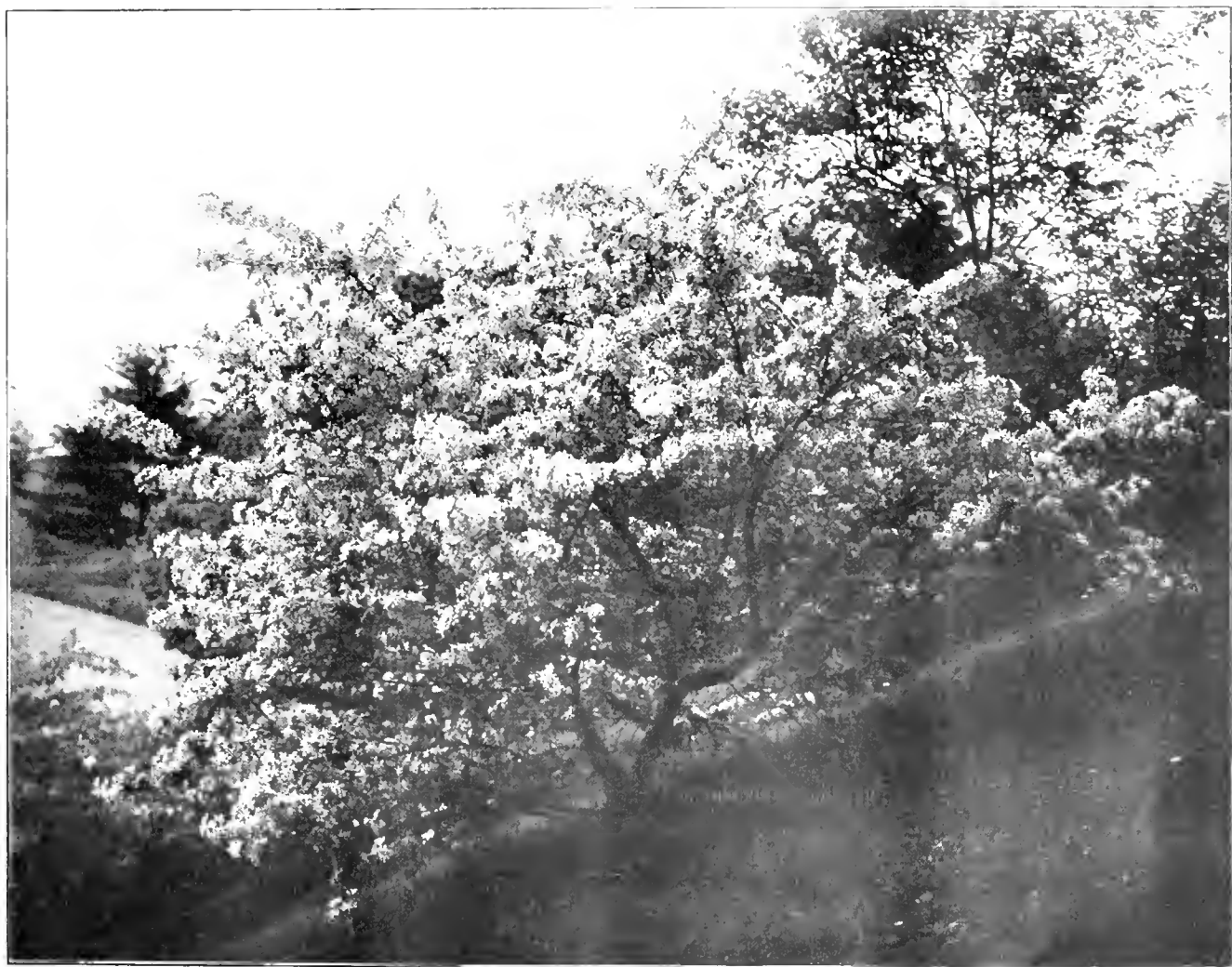

PYRUS FLORIBUNDA

Devoted to the
**FLORIST, PLANTSMAN,
LANDSCAPE GARDENER**
and
Kindred Interests

Published
EVERY SATURDAY
At 11 Hamilton Place,
BOSTON, MASS.
Subscription, \$1.00

CANNA BULBS

Fine plump, Northern Grown, and in fine condition. Not to be compared with southern grown stock, that are never thoroughly ripened and therefore are very slow to start growing.

	Doz.	100	1000		Doz.	100	1000
Allemania	\$0.35	\$2.50	\$22.50	Gladator	\$0.40	\$3.00	\$27.00
Black Prince	.40	3.00	27.00	King Edward	.50	3.50	32.00
Black Warrior	.35	2.50	22.50	Louisiana	.55	4.00	35.00
Burbank	.30	2.25	20.00	Mad, Crozy	.40	3.00	27.00
Black Musafolia	.40	3.00	27.00	Mile. Berat	.30	2.25	20.00
Charles Henderson	.35	2.50	22.50	Musafolia	.30	2.25	20.00
Director Roe z	.35	2.50	22.50	Paul Marquant	.30	2.25	20.00
Flamingo	.30	2.25	20.00	Pres. McKinley	.35	2.50	22.50
Florence Vaughan	.35	2.50	22.50	Queen Charlotte	.35	2.50	22.50
Golden Star	.30	2.25	20.00	Robusta	.30	2.00	18.00
				Red Cross	.30	2.25	20.00

STUMPP & WALTER CO., 50 Barclay St., NEW YORK

PELARGONIUMS

We have a fine lot of good strong plants in 3 inch pots at \$1.50 per dozen, \$6.00 per 100; such varieties as Purity, Gloria, Countess of Crew, Tommy Dodd, Duke of Cornwall, Lady Carrington and others.

GERANIUMS

A splendid stock of fine plants from 2 inch pots, good standard sorts and new varieties at \$2.00 per 100 and up to \$1.00 each. We will send 1000 in 20 good varieties, our selection, for \$18.50. Our special descriptive Geranium Catalogue, describing over 250 varieties of Geraniums and Pelargoniums mailed free to the trade.

HARDY CHRYSANTHEMUMS

Our collection of Hardy Chrysanthemums will compare favorably with any in the country and we have an immense stock ready for shipment. Small flowered or Button Varieties, \$2.00 per 100. Large Flowered or Aster Varieties, \$3.00 per 100. Descriptions will be found in our Wholesale List.

DAHLIA ROOTS

We still have about 75 varieties we can offer in Cactus, Decorative, Show and Pompon true to name at \$5.00 per 100 and up for Whole Field-grown clumps. One thousand, 50 each of 20 varieties, our selection, for \$40.00, all good kinds; a splendid collection for planting or just the thing for Store Trade.

	Per 100		Per 100
Ivy Leaved Geraniums, 6 good kinds, \$25.00 per 1000	\$3.00	Hardy English Ivy, Extra Strong, \$15.00 per 1000	\$2.00
Hardy Chrysanthemums, 75 var.	2.00-3.00	Hollyhocks, Strong 3 in. pot plants, dbl. white, pink, red and yellow	3.00
Alyssum, Giant Double	2.00	Lobelia, Crystal Palace Gem	2.00
Cuphaea, Cigar Plant	2.00	Panicum, Variegated, Handsome basket plants	2.00
Coleus, Verschattelt, Golden Pedder and other kinds	2.00	Tradescantia, Dark Variegated	2.00
Swainsona, Alba	2.00	Verbena, Red, White, Purple and Pink	2.00
Fuchsias, Black Prince and Minnesota-Lieutenant Muritz, White and Rose-Phenomenal	2.50	Caladium, Esculentum, 1st size \$2.00 per 100; 2nd size	1.00
		Lavender, 2 1/2 in. pots strong	3.00
		Lantanas, 5 varieties	2.00

R. VINCENT JR. & SONS COMPANY, White Marsh, Md.

AZALEAS

for fall delivery, the best that are grown, also

PALMS

for spring or fall delivery, furnished by Belgium; orders booked now

AUGUST ROLKER & SONS, 31 Barclay Street, or P. O. Box 752, New York

CANNAS

Send for our List and Prices

The CONARD & JONES CO. WEST GROVE, PA.

Herbaceous Perennials

A complete stock of the most desirable of the standard varieties.

RED OAK NURSERIES FISKEVILLE, R. I.

ROBERT CRAIG CO.

ROSES, PALMS,

and Novelties in Decorative Plant's

MARKET and 49th STREETS, PHILADELPHIA, PA.

Decorative Plants

Azaleas, Kent as, Rubbers, Arecas Araucarias, Pandanus, Box Trees, Euonymus, Crotons, and Eurya latifolia.

Extra good value in

EASTER PLANTS

Order Ahead.

A Leuthy & Co.

Perkins Street Nurseries, Roslindale, Mass.

GODFREY ASCHMANN

Importer and Wholesale Grower and Shipper

of Araucaria Excelsa, Compacta, Robusta and Glauca; Kentia Forsteriana and Belmoreana Azalea, Indica, etc. Cultivator of Boston, Scottii, Barrowsii, Elegantisima and Whitmanii Ferns. Ferns for dishes, Cocos, etc. Write for prices.

1012 Ontario St., Philadelphia

1/4 MILLION CANNAS

Good Tubers 2 to 3 Eyes TRUE TO NAME

ORDER NOW FOR DELIVERY ANY TIME

Red and Crimson Cannas

	Doz.	100	1000
Louisiana, 7 ft. high, 10c. each	\$1.00	\$10.00
A. Bouvier, 5 ft.	.35	2.25	\$20.00
Beaute Polievine, 3 1/2 ft.	.35	2.25	20.00
Chas Henderson 4 ft.	.30	2.00	17.50
Crimson Bedder, 3 ft.	.35	2.25	20.00
Duke of Marlborough, 4 1/2 ft.	.35	2.75	25.00
J. D. Elsele, 5 ft.	.35	2.25	20.00
Explorateur Crampbel, 5 1/2 ft.	.30	2.00	17.50
Express, 2 to 2 1/2 ft.	.60	4.50	40.00
Flamingo, 4 1/2 ft.	.30	2.00	17.50

Pink Cannas

L. Patry, 4 1/2 ft.	.35	2.25	20.00
Luray, 3 ft.	.35	2.25	20.00
Louise,	.35	3.50	25.00
Mile Berat, 4 1/2 ft.	.35	2.25	20.00
Tennyson, 5 1/2 ft.	.50	3.00

Orange Scarlet Cannas

Pres. Cleveland, 4 ft.	.35	2.25	20.00
------------------------	-----	------	-------

Red, Gold-Edged Cannas

	each	1.50	10.00
Indiana, 3 to 4 ft. high, 15c.				
Time Crozy, 5 1/2 ft.	.40	2.75	25.00	
Souv. de A Crozy, 4 ft.	.40	2.75	25.00	
Premier, 2 1/2 ft.	.35	2.25	20.00	

Yellow Cannas

Buttercup, 3 1/2 ft.	.75	4.25	40.00
Comte de Buchard, 4 1/2 ft.	.35	2.25	20.00
Florence Vaughan, 5 ft.	.50	2.75	25.00
L. E. Bailey, 4 1/2 ft.	.30	2.00	17.50

Bronze-Leaved Cannas

Brandywine, 4 to 5 ft.	.35	3.50	25.00
Black Beauty, 5 ft.	.50	2.75	25.00
David Harum, 3 1/2 ft.	.50	3.25	30.00
Eganate, 4 ft.	.50	2.75	25.00
Leonard Vaughan, 4 1/2 ft.	.50	2.75	25.00
Musafolia, 3 ft.	.35	2.25	20.00
Robusta, 6 to 8 ft.	.30	1.75	15.00
Shenandoah, 6 ft.	.35	2.25	18.00
Stadtrath Heidenreich, 4 1/2 ft. 20c. each	2.00	15.00

Orchid Cannas

Allemania, 4 to 5 ft.	.35	2.25	20.00
Austria, 5 ft.	.30	1.75	15.00
Italia, 4 1/2 ft.	.35	2.25	20.00
King Humbert, 4 ft.	1.25	10.00	80.00
Kronus, 5 ft.	.35	2.25	20.00
Mrs. Kate Gray, 6 ft.	.35	2.25	20.00
Pennsylvania, 5 ft.	.50	2.75	25.00

All above Cannas packed 250 in a case. Full case at 1000 rate; 25 at 100 rate.

Caladiums Esculentum (Elephant's Ear)

Bulbs 6 to 8 in. circum.	.25	1.50	10.00
Bulbs 8 to 10 in. circum.	.50	3.50	30.00
Bulbs 10 to 12 in. circum.	.75	5.50	50.00
Bulbs 12 to 13 in. circum.	1.00	8.00	75.00
Monster Bulbs measuring 12 in. and upwards in circum. \$1.50 per doz.; \$12.00 per 100.			

Our Wholesale Catalogue of Quality seeds and bulbs now ready. It contains forty pages of seeds and bulbs you need fully described. Write for it today—a postcard will fetch it.

ARTHUR T. BODDINGTON

SEEDSMAN

342 W. 14th St., New York City

CARNATION CUTTINGS

We are in unusually good position to supply exceptionally well-rooted, healthy stock. We have such a large quantity of flowering plants that we propagate only from heel cuttings from flowering shoots. Our cuttings are rooted in light, sunny, airy houses, and we are sure will satisfy the most critical buyer. A prominent carnation grower writes, "You seem to be the only firm in the business that knows how to pack stock and have it reach the buyer in good condition, and I have always found your cuttings cheaper than the same varieties from others at much lower figures." While our prices may not always be the cheapest, we certainly can give, quality considered, as good value as, if not better than, is obtainable anywhere.

WINSOR which we introduced last year has proved to be the finest novelty introduced in years. We think it is the most profitable variety grown today, considering its fine color, splendid keeping qualities, and productiveness. When properly grown, it leaves little to be desired, and almost every one succeeds with it.

WHITE ENCHANTRESS the best all-round white carnation, on account of its large size, long stem, earliness, and productiveness. Our White Enchantress, exhibited at the Carnation Convention at Washington, was the only White Enchantress exhibited that received an award.

Strong rooted cuttings, now ready for delivery, from sand \$6 per 100, \$50 per 1000; from soil, \$7.50 per 100, \$60 per 1000.

We offer also **Beacon** and **Red Chief**, from sand, \$6 per 100, \$50 per 1000; from soil, \$7.50 per 100, \$60 per 1000. Also **Victory**, **Melody** and **White Perfection** from sand, \$4 per 100, \$35 per 1000; from soil, \$6 per 100, \$45 per 1000. **Variegated Lawson**, **White Lawson** and **Red Lawson**, from sand, \$3 per 100, \$25 per 1000; from soil, \$4 per 100, \$35 per 1000. We can supply, also, **Winona** and **Alterglow** at \$12 per 100, \$100 per 1000.

Buyers will find transplanted stock offered from soil well worth the difference in price

F. R. PIERSON CO., - - Tarrytown-on-Hudson, NEW YORK

WINSOR and WHITE ENCHANTRESS *Immediate Delivery*

From sand \$6 per 100, \$50 per 1000; from soil \$7.50 per 100, \$60 per 1000; from pots \$9 per 100, \$75 per 1000

Satisfaction Guaranteed. WHITE BROS., Gasport, N. Y. Try Us.

Rooted Carnation Cuttings

Pink	100	1000
Aristocrat.....	\$6.00	\$50.00
Winsor.....	6.00	50.00
Rose Pink Enchantress	3.50	30.00
Enchantress.....	3.00	25.00
Lawson.....	2.50	20.00
Joost.....	2.00	15.00

White		
White Perfection.....	3.00	25.00
" Lawson.....	3.00	25.00
Queen.....	2.00	18.00
Boston Market.....	2.00	18.00
Louise.....	2.00	18.00
Lt. Peary.....	3.00	25.00
Bountiful.....	2.50	20.00

Red		
Beacon.....	6.00	50.00
Victory.....	3.00	25.00
Robert Craig.....	3.00	25.00
Flamingo.....	2.50	20.00

Miscellaneous		
Patten.....	2.50	20.00
Harry Fenn.....	2.50	20.00
Har'owarden.....	2.50	20.00

Stock Guaranteed—Prompt Deliveries

THE LEO NIESSEN CO.
WHOLESALE FLORISTS
1209 Arch St., PHILADELPHIA

Single Chrysanthemums ARE THE CRAZE

for the time being.

Are you in line to meet the demand?

I have now ready:

KATIE COVELL, ROB ROY, HELEN TOTTY, HAROLD BISHOP, MRS. UNTERMEYER, ANNA SPANGLE,

and others, at

\$2.00 per doz., \$15.00 per 100.

I also carry a full line of novelties and standard varieties of

Chrysanthemums, Carnations and Roses

CHAS. H. TOTTY, MADISON, N. J.

CARNATIONS ROOTED CUTTINGS

Winona, color, true clear pink, comes nearest to Fiancee but a different type flower. Growth on order of Scott but vastly improved in every respect. Early flowers in quantity and on long stems. Does not burst its calyx. Fine, shapely, active growth. In color and productiveness it is without an equal. Orders booked now and filled in strict rotation. \$12 per 100, \$100 per 1000.

White Perfection, pure white. We have a large stock. \$3 per 100, \$25 per 1000.

F. DORNER & SONS CO.
LA FAYETTE, IND.

DAHLIAS. Now is the time to place your order for bulbs which will insure you getting named varieties in any quantity; prompt delivery.

DAVID HERBERT & SON,
Successors to L. K. Peacock, Inc.
ATCO, N. J.

LLOYD IS THE REAL THING The Carnation for every one to grow

LLOYD is a commercial white, with a fancy flower

The only ever-blooming, large-flowering white in existence

Will take the place of all other whites now in commerce. Every New Bedford grower has bought stock. Come and investigate.

**A KEEPER
A SHIPPER
A BLOOMER**

It will bring the shekels when all others fail

\$2 pr 12. \$12 pr 100. \$100 pr 1000

Unrooted Cuttings
\$6 per 100. \$50 per 1000.

H. A. JAHN

NEW BEDFORD, - - MASS.

Carnation Cuttings

Both standard varieties and novelties. Stock guaranteed to be first-class. Address,

S. S. SKIDELSKY

1741 North 18th Street. Philadelphia

ROOTED CARNATION CUTTINGS

Only the Best Varieties

CHICAGO CARNATION CO., JOLIET ILL.

JOHN E. HAINES Bethlehem, Pa.

is the place to order rooted-cuttings of the following varieties for 1908.

John E. Haines, red Imperial variegated	Per 100	Per 1000
Pink Imperial, Pink Enchantress, Light Pink		
	\$6.00	\$50.00

Place your orders early for Jan. delivery.

PRICES QUOTED IN THESE COLUMNS ARE FOR DEALERS ONLY

When Writing to Advertisers Please Mention Horticulture

300,000 CALIFORNIA PRIVET

1-year-old, 18-24 in. high, 2-4 branches.....	Per 1000	\$15.00
2-year-old, 2 1/2 ft., 3-2 and 10 branches.....	Per 1000	\$25.00
3-year-old, standard, 3-6 ft., heads 2-1/2-3 1/2 ft. diameter.....	Per 100	75.00
4-year-old, standard, 4-5 ft., heads 2-1/2 ft. diam.....	Per 100	50.00
5-year-old, standard, 4-5 ft., heads 18-24 in. diam.....	Per 100	40.00
6-year-old, pyramidal, well sheared, 4-5 ft. high, 3-4 ft. diameter.....	Per 100	75.00
7-year-old, 3-4 ft. high, pyramidal, 2 1/2-3 ft. diam.....	Per 100	50.00
8-year-old, 2 1/2-3 ft. high, pyramidal, 18-24 in. diameter.....	Per 100	40.00
Elms, Am., fine trees, 11-12 ft. high, 1 1/2-2 in. cal.....	Per 100	40.00
Elms, Am., fine trees, 9-11 ft. high, 1 1/2-1 3/4 in. cal.....	Per 100	30.00
European Linden, 12-15 ft. high, 2-3 in. cal.....	Per 100	60.00
Althaea, double white with maroon center, 3-6 ft. high.....	Per 100	15.00
Althaea, double white with maroon center, 4-5 ft. high.....	Per 100	12.00
Althaea, double white with maroon center, 3-4 ft. high.....	Per 100	10.00
Spiraea Billardii, 4-ft. high.....	Per 100	6.00
Forsythia Viridissima, 3-4 ft. high.....	Per 100	10.00
Lilac Rubra, Dr. Marley, 3-4 ft. high.....	Per 100	10.00
Deutzia Crenata, 4-5 ft. high.....	Per 100	11.00
Deutzia Gracilis, 4-year-old plants.....	Per 100	8.00
Yucca Filamentosa, blooming plants.....	Per 100	35.00

I will have a large collection of bedding plants for Spring delivery out of 25 greenhouses, such as Roses, Geraniums, Coleus, Heliotrope, Salvia Bonifure, or Scarlet Sage (which is the best bedding plant today), Lantanas, Verbenas, Begonias, Vinca Rosea, Alternantheras, red, yellow and pink; all kinds vase and hanging basket plants.

Send me your wants and I will give you price.

Carlman Ribsam

Office, 31 Wall St., TRINTON, N. J.
Greenhouses, East State St.
Nursery, Hamilton Ave.

BUY IN SEASON

Seedlings and Rooted Cuttings, extra fine, well rooted; three grades, just right for lining out: *Pignolia Glauca* (Sweet Bay), *Ampelopsis robusta purpurea* (New), *Ibota Privet* (Jap.), *Berberis Thunbergia* (Jap.), *Berberis Vulgaris* (Native) *Arborvitae American* and *Siberian*, Spruce, White Pine and Hemlock.

It will pay you to get our prices NOW
PIERCE NURSERY
BEVERLY FARMS, MASS.

The MORRIS NURSERY CO.
West Chester, PA.
NURSERIES ESTABLISHED 1849

SPECIALTIES for SPRING 1908

Norway Maple, 2 1/2 in. dia. and 2 1/2-3 in. dia.
Carolina Poplars, 10-12 ft., 1 1/2-2 in.
Cal. Privet hedge Plants 2 yrs. old 2-3 ft. and 3 and 4 yrs. old 3-5 ft. Dwarf Box, 3-6 in.
Rhododendron Hybrids, 18-24 in. and 2-3 ft. choice hardy varieties Rhododendron Maximum, 2-8 ft., fine plants in car lots.
Kalmia Latifolia 1-4 ft., fine plants in car lots.
Blue Spruce, Koster's, 3-5 ft.
1 hybrid Roses, choice varieties.

Catalogue mailed upon request. Address all communications to

The MORRIS NURSERY CO.
Sales office, 1 MADISON AVE., NEW YORK

AMERICAN NURSERY COMPANY
COMBINING

FRED'K W. KELSEY New York City
F. & J. NURSERIES Springfield N. J.
BLOODGOOD NURSERIES, Flushing L. I.
N. J. & L. I. NURSERIES.

We Can Supply Your Every Need. Write for Prices
150 Broadway
SALES DEPARTMENT, New York.

NEW My Maryland ROSE

"My Maryland" has more good commercial points than any other Rose. Price, 2 1-2 inch pots, \$25.00 per hundred; \$200.00 per 1000; \$5.00 per dozen.

JOHN COOK, 318 N. Charles St., Baltimore, Md.

TAUSENDSCHON

or in English **Thousand Beauties**, is the sensational new Climbing Rose of the year. Every florist should have it. It is not excelled for forcing purposes and for general planting by any Climbing Rose now known, **not even bar-ring Crimson Rambler**. This is the coming forcing Rose. Get your stock early. Illustrated in ten colors and gold in our Catalogue for 1908, the **Leading Rose Catalogue of America**. Every Rose worth having is described in it. Copy free for the asking.

Strong plants of Tausendschon from 3-inch pots,
10 for \$1.50; \$12.00 per 100; \$100.00 per 1000.

THE DINGEE & CONARD CO., WEST GROVE, PA.

HARDY NORTHERN GROWN NURSERY STOCK

At Reasonable Prices

FRUIT AND ORNAMENTAL TREES, SHRUBS, VINES, ROSES AND HERBACEOUS PERENNIALS IN GREAT VARIETY

Catalogue and Price List for the asking

BAY STATE NURSERIES, NORTH ABINGTON, MASS.

NEW NEW RAMBLER ROSE "NEWPORT FAIRY"

To be disseminated Spring, 1908. Ask for illustrated pamphlet and prices

JULIUS ROEHR'S CO., Rutherford, N.J.

SPECIMEN EVERGREENS

Box Plants, Azaleas, Rhododendrons, Roses, Herbaceous Perennials

In fact everything in hardy stock for Garden, Lawn and Landscape Planting.

General Catalogue and Trade Lists on application.

The NEW ENGLAND NURSERIES, Inc., Bedford, Mass.

COMPLETE LINE OF

Hardy Trees, Shrubs, Vines, Evergreens and Perennials

Order now for early delivery. Send for illustrated catalogues

EASTERN NURSERIES, M. M. DAWSON, Mgr. Jamaica Plain, Mass.

Hardy Rhododendrons, Azaleas Conifers, Clematis, H. P. Roses, Shrubs and Herbaceous Plants from our
HOLLAND NURSERIES

Prices Moderate

P. DUWERKERK, 246 Jane St., Weehawken Heights, P. O. No. 1, Hoboken, N. J.

Look through the Buyers' Directory and Ready Reference Guide. You will find some good offers there also

BARGAINS in TREES and PLANTS

Six for 25c, delivered free by mail
List Free. D. J. F.W. MEY, Dept. H., Geneva, N. Y.

Hardy Roses

American Grown—Superior to Imported

We have unsold at the present time the following varieties—all field grown plants, grown in our nurseries at Rochester, N. Y.:

- | | |
|---------------------|-----------------------|
| Anne de Diesbach | Prince Camille |
| Chlo | Elrich Benner |
| Frau Karl Bruschki | Crimson Rambler |
| General Jacqueminot | White Rambler |
| John Hopper | Yellow Rambler |
| Mme. G. Luizet | Philadelphia Rambler |
| Marshall P. Wilder | Common Sweet Briar |
| Mrs. John Luing | Mme. G. Brundt |
| Paul Neyron | Wichuriana (The Type) |

These plants are in our storage cellars and can be shipped at any time. Prices on request.

ELLWANGER & BARRY

Nurserymen—Horticulturists
Mount Hope Nurseries, Rochester, N. Y.

FLOWERING APPLES

The various ornamental apples included under the popular term "flowering" apples, surpass in floral beauty the trees and shrubs blooming at their particular season. Yet, notwithstanding their great attractiveness, they are used very little as compared with most ornamental plants. This fact is probably due, to a large extent, to a lack of any widespread knowledge or appreciation of their worth. Some have been displaying their beauty in our gardens for a long time, while others are comparatively recent introductions from Asia. They are large shrubs or small trees, having a form often somewhat irregular, yet in the case of some species rather symmetrical, bearing an abundance of charming flowers within range in color from white through shades of pink to almost blood-red, and frequently bearing fruit which is attractive in the late summer and autumn.

As to their Demands.

They do not require more than the average ornamental shrub or tree and, for the most part, they are not fastidious as regards soil or situation. Some few need garden cultivation, while others succeed in ordinary soil even on somewhat dry banks. However, they all respond earnestly to good deep soil and careful treatment. Moreover, they are perfectly hardy and vigorous. As to pruning, in the early years of the plant's life it is practically identical with that of the fruiting apple, while later it consists essentially in removing dead and interfering branches.

The Uses to Which They May Be Put Are Many.

They have their place in the small city yard and on the larger city estate as well as on the large country place. Some may be appropriate in the garden or on the lawn as specimens, others may be desirable in the back of the shrubbery, while many of them are particularly well adapted to border plantations and screens. Then some, as the Wild Crab Apple (*Pyrus coronaria*), are very attractive when situated on the borders of a natural wood. After all, there is no gainsaying that they are most effective when in masses, especially where there is a background of green, as that offered by a grassy bank or a growth of coniferous trees. Although this larger use seems to be most desirable, the fact should discourage no one from planting them on small areas and in limited numbers, for a single plant in a garden or on a small lawn is capable of affording as much pleasure during its season of bloom as any individual plant possibly can.

The Period of Bloom of These Apples.

It is a trifle over three weeks. Most of them flower profusely year after year. In the vicinity of Boston the earliest, the Siberian Crab (*Pyrus baccata*) and its varieties, begin to unfold their flower buds the latter part of the first week or early in the second week in May; and the last to delight us with its charm, the Wild Crab Apple (*Pyrus coronaria*), passes out of bloom early in June. Almost simultaneously with those of the Siberian Crab ap-



Pyrus Toringo.

pear the delicate pink blooms of the Flowering Crab (*Pyrus floribunda*). When the Siberian Crab is at its height, Parkman's Crab (*Pyrus Halliana*) is beginning to release the restraint on its rosy petals and in less than a week will grant them full freedom. At the same time the Chinese Flowering Apple (*Pyrus spectabilis*) is largely opening its most advanced buds which a week later will be in full expansion. This is the most tenacious of its flowers of any of these apples, and is in good condition for the longest period. When Parkman's Crab is a little past full bloom and the Chinese Flowering Apple is about in its prime the Dwarf Crab (*Pyrus Toringo*) may be making its display. When this is over, one may expect to find the Western Crab Apple (*Pyrus ioensis*) and the Wild Crab Apple (*Pyrus coronaria*) covered with their rosy-red fragrant flowers. How unobtrusive they are as they nestle in the fresh living green of the unfolded leaves! Yet how certain they are to catch your attention, and how tenaciously they hold it! Is not their perfume sweet? It is that of the apple, yet more refined and withal more intense and all-pervading. Providential it is that these are reserved by Nature to terminate her brilliant array of flowering apples.

The Siberian Crab (*Pyrus baccata*).

Now, is it not worth the while to devote ourselves to making their personal acquaintance? As the Siberian Crab is the first to greet us, it is only courteous to cultivate its friendship. Although growing wild from Siberia and Manchuria to the Himalayas, it has been cultivated in Europe for a long time and in China and Japan from time immemorial. The plants offered in this country are in all probability varieties or crosses and not the true species. It is a small spreading tree sometimes becoming as large as the apple and reaching a height of thirty feet. The flowers are usually white and appear in abundance with the

leaves on long green flower stalks. Following the flowers come the little apples, ranging in size from a quarter to three-quarters of an inch in diameter, and yellow or red in color. When in bloom the tree is a beautiful object, and again at fruiting time it is interesting, yet it should not rank high in this list. What will shortly be said in the case of the Flowering Crab as regards hardiness, vigor and ease of establishment, applies to the Siberian Crab, and likewise the uses to which they may be put are identical.

The Flowering Crab (*Pyrus floribunda*).

This is an extremely attractive plant from Japan. It is a shrub or small tree, low and bushy in form, branching from near the ground and ultimately growing to a height of twenty feet. The flowers are rose-colored, an inch across, and completely cover the plant. The slightly loosened buds with their bright red hue are nearly as attractive as the unfolded blooms, and the combination of buds and open flowers is charming. Then follow the small red apples, about the size of a pea, borne on slender stems. These are rather interesting during the late summer and early fall but do not persist until winter. All in all, this is the best of our exotic apples and, in fact, ranks very high among ornamental plants. It is good in a garden, but most effective when used in masses. This is one of the apples very well adapted to forming screens or to use in border plantations. It is hardy, sturdy and easy to establish and grow.

Parkman's Crab (*Pyrus Halliana*)

is a bush or small tree, with loose open crown, somewhat unsymmetrical in habit and as a rule not exceeding a height of fifteen feet. It has pleasing leathery foliage in moderate abundance. The flowers are rose-colored, usually semi-double, pendulous on slender reddish flower-stalks. The fruit is about a quarter of an inch in diameter, brownish-red and ripens in

late fall. Although its beauty depends almost entirely on the bloom, it is particularly handsome and as regards delicate modeling and exquisite coloring it is the most charming of the group. It is not as vigorous a grower as most of these plants and is more exacting in its demands if one is to get the most satisfactory results. It is decidedly a plant for a garden or lawn and should not be placed in poor soil or in trying situations.

The Chinese Flowering Apple (*Pyrus spectabilis*)

is an apple which has been long in cultivation. It is a small shrub-like tree growing under garden cultivation from twenty to twenty-five feet high. The branches are upright in habit of growth, rather symmetrical, and when the plant reaches maturity the form is vase-like. The foliage is of moderate density and the leaves are thick and of a dark green color. However, the foliage has no particular merit and is inferior, as I believe, to that of most of the apples. The flowers of the forms growing in cultivation are semi-double, nearly an inch across when fully expanded, pale rose in color fading to white, and of delightful fragrance. They appear in great profusion each year, and in the vicinity of Boston begin to open about the middle of May. Fruit is rarely borne and is of no consequence for ornamental purposes. It is easy to grow and is one of the desirable trees for a small place, yet it is very little planted at the present time, although it is one of the older introductions formerly much used. As Loudon remarked, "no garden, whether large or small, ought to be without this tree."

The Dwarf Crab or Toringo (*Pyrus Toringo*)

is a spreading shrub or dwarf tree from Japan. The leaves are deeply incised and often three-lobed, a distinguishing feature of the species. The flowers are smaller than those of the other apples, white or bluish in color and borne on slender stems. The fruit is minute, red or yellow. In contrast to the other apples, this species has interesting autumnal coloring, the leaves assuming a deep purple. This is less valuable than many of the plants which we are considering, yet it is certainly worthy of a place where one is grouping them.

Pyrus Scheideckeri.

Turning from these well tried exotic species perhaps it may be well to gain the acquaintance of some of the newer introductions. Of these *Pyrus Scheideckeri* is a plant of German origin, the scientific disposition of which is in doubt. It is a small round tree, upright in habit and very much resembling the Flowering Crab. The flowers are double, red changing to rosy pink, and open a little later than those of the Flowering Crab. Then they are very tenacious, perhaps even more so than the flowers of the Chinese Flowering Apple. It is hardy, vigorous and certainly promises very well.

Pyrus Niedzwetzkyana.

Coming from the Russian Caucasus is a new apple, the *Pyrus Niedzwetzkyana*. When in bloom at the Arnold Arboretum in the spring of 1905 it was perhaps the most striking object there. It is a small tree with an open and



Pyrus Scheideckeri.

somewhat irregular roundish head. The new leaves are deep purple in color, becoming at maturity a deep green. The wood of the newer growths is also purple. The flowers are single, borne profusely and deepest in color of any of this group, being an intense purplish red. It is one of the earliest to bloom, being in its prime a little after the Siberian Crab. It is hardy, apparently vigorous, and seems destined to make an excellent garden or lawn tree.

The Wild Crab Apple (*Pyrus coronaria*).

Of our own native apples the Wild Crab Apple is the best, comparing favorably with the most satisfactory exotic species. It is indigenous to the forest glades of the region south of the Great Lakes and among the Allegheny Mountains. In form it is a low, bushy tree, growing under favorable circumstances to a height of twenty-five or thirty feet, while its branching is characteristically stiff and angular. It is a late bloomer and prolongs the display of apple blossoms, a fact which gives it decided value aside from its other merits. Perhaps it is less showy than most of the members of this group because the leaves have unfolded when the flowers appear. These are white or rose-color, nearly two inches across when fully expanded, and delightfully fragrant. The fruit is about an inch across, waxy, yellowish green, possessing some ornamental value and serving for jellies and preserves. The plant is perfectly hardy, vigorous and easy to grow. It is best used in masses, either in conjunction with others of the flowering apples or with strong growing shrubs or low trees. It could be successfully employed in

screen or border plantations, and would be admirably placed when used on the margin of a natural woodland. All in all it is the most meritorious of the apples as well as one of the most desirable of small trees.

The Western Crab Apple (*Pyrus loensis*)

is a small tree native to the West, very similar to the preceding. The habit of growth is very much like that of the Wild Crab Apple, while the color of the flowers and the period of their expansion are practically the same. Likewise the treatment and use would be identical. Although it is doubtful if the type is sufficiently distinct to warrant planting, this certainly cannot be said of the beautiful double-flowered form known as Bechtel's Crab.

Now to assemble the attributes and emphasize the fitness of our old and newly acquired friends. We have found them to be hardy, sturdy and far from exacting in their requirements. Their adaptation to a wide field of usefulness is evident and their fitness to their particular tasks goes without saying, whether it is to gladden a garden or lawn as specimens, to enliven the background of shrubbery, to add cheer to a screen or boundary planting, or to brighten the borders or open glades of some native woodland. Their beauty is beyond portrayal. The rose with its suffused fragrance and its delicate splendor is no rival when their branches arch beneath the many flowers, all modest in the presence of their own wonderful coloring.

Daniel A. Clarke.

MARKET EXHIBITION AT BOSTON

The Park Street Market Exhibition at Boston on Saturday, February 29, was all that its promoters had promised and a great deal more. In extent and quality of exhibits it far exceeded any of its predecessors. During the entire day the room was thronged and for most of the time the crush was so great that it was with the greatest difficulty that the judges performed their duties. Rarely is a more perplexing job given to a set of judges than was here presented, the entries being so numerous and the excellence being so general, and the work was not completed until well along into the afternoon. It became apparent early in the day that the market room would be entirely inadequate to properly display the flowers or to accommodate the crowd of visitors, and much regret was expressed that the committee had not accepted the invitation extended by the Massachusetts Horticultural Society to occupy Horticultural Hall for the show. Apprehension that change of location might tend to a loss of individuality was the explanation given by the committee for their decision to remain in their own quarters but it is likely that next year the need of larger space will be imperative.

As the list appended will show, the entries from outside of New England territory were not numerous, although all of conspicuous interest, but the home growers were certainly out in force and it was the universal verdict of visitors from afar that New England growers of roses, carnations, violets and sweet peas are well in the lead.

Among the sensational exhibits none came in for more astonished admiration than W. H. Elliott's Richmond and Killarney roses. S. J. Goddard's Priscilla is generally recognized as a carnation with a big future. S. J. Goddard's Victory was beaten by Beacon but no better Victory has ever been seen. On the other hand Helen Goddard beat Lawson. Altogether, S. J. G., with seven first and six seconds, and a silver cup, had nothing to find fault with. Fisher's winning six in the Hews cup competition, were Evangeline, Winsor, White Perfection, Mrs. C. W. Ward, Enchantress and Beacon. The display of violets was the best on record in Boston. C. Cummings, Wm. Spillsbury, E. Bingham, Paul Richwagen, Kidder Bros., W. E. Turner, C. E. Streamburg, Esty Bros., E. A. Richards, H. W. Field, H. F. Woods and Wm. Sim were all in the running. Worthy of special mention also were F. W. Fletcher's myosotis, R. T. McGorum's candytuft, F. C.

White's wallflower, A. C. Zvolanek's new lavender pea, Mrs. Chas. Totty, R. D. Kimball's and Paul Richwagen's snap-dragon and H. M. Robinson & Co.'s gardenias. J. Fuller's handsome double blue lobelia caught all eyes. Mr. Fuller says that this variety enjoys starvation and gives best results as a bedding plant when plunged in the beds, in small pots.

THE AWARDS.

Carnations.

In class A for vases of fifty carnations, disseminated varieties, the winners were as follows:

- Dark Red, 1st., Edw. Winkler, Harry Penn; 2nd., S. J. Goddard, Octoroon.
- Dark Pink, 1st., S. J. Goddard, Helen Goddard, 2nd., Peirce Bros., Lawson.
- Light Pink, 1st., S. J. Goddard, Enchantress; 2nd., Peter Fisher, Winsor.
- Scarlet, 1st., Peter Fisher, Beacon; 2nd., S. J. Goddard, Victory.
- White, 1st., Patten & Co., White Perfection; 2nd., S. J. Goddard, White Perfection.
- Variiegated, 1st., Leonard Cousins, Jr., Variiegated Lawson.

Class B, for vases of twenty-five carnations, disseminated varieties:

- Dark Red, 1st., S. J. Goddard, Harry Penn; 2nd., Littlefield & Wyman, Octoroon.
- Dark Pink, 1st., Littlefield & Wyman, Lawson; 2nd., S. J. Goddard, Helen Goddard.
- Light Pink, 1st., Chas. S. Strout, Enchantress; 2nd., Littlefield & Wyman, Winsor.
- Scarlet, 1st., S. J. Goddard, Victory; 2nd., Littlefield & Wyman, Robert Craig.

- White, 1st., Patten & Co., White Perfection; 2nd., S. J. Goddard, Lady Bountiful.
- Variiegated, 1st., Peirce Bros., Mrs. M. A. Patten, 2nd., Backer & Co., Mrs. M. A. Patten.

Class C, 100 blooms in one vase, not less than six disseminated varieties. Silver cups.

- 1st., S. J. Goddard; 2nd., Peirce Bros.
- Class D, Vase of 100 blooms one variety, new or standard. Silver cup. Peter Fisher, White Perfection.

- Vase of new striped variety, 1st., S. J. Goddard, Priscilla; 2nd., New Hampshire College, Durham, N. H., Seedling.
- Vase of 25 blooms unnamed seedlings, 1st., Patten & Co., Crimson, 5024; 2nd., Patten & Co., Yellow, 213; 3rd., Patten & Co., White, 46205.

Class E, A. H. Hews cup for six varieties in vases of fifty each, 1st., Peter Fisher.

F. R. Pierson Company prizes for twenty-five Winsor, 1st., Peter Fisher; 2nd., Peirce Bros.

Peter Fisher prizes for fifty Beacon, 1st., S. J. Goddard.

Ditto for twenty-five Beacon, 1st., Chas. S. Strout.

Roses.

Twenty-five American Beauty, 1st., Waban Rose Conservatories.

Twenty-five Killarney, 1st., W. H. Elliott.

Twenty-five Richmond, 1st., W. H. Elliott; 2nd., Waban Rose Conservatories.

Twenty-five Bridesmaid, 1st., Montrose Greenhouses; 2nd., W. H. Elliott.

Twenty-five any other color, W. H. Elliott, Safrano.

Park Street Flower Market prize for best new rose to be disseminated in 1908, silver cup, to W. P. Craig for Mrs. Jardine.

W. E. Doyle cup for 25 Killarney, to W. H. Elliott.

Sweet Peas.

One hundred White, 1st., Wm. Sim; 2nd., H. M. Sanderson.

One hundred Pink, 1st., Wm. Sim; 2nd., H. M. Sanderson.

A. C. Zvolanek Trophy for two vases of 200 each, Florence Denzer and Christmas Pink sweet peas, Wm. Sim.

Violets.

One hundred Lady Campbell, 1st., H. F. Calder; 2nd., H. F. Wood.

One hundred any other double, 1st., Paul

Thompson, Imperial; 2nd., H. M. Sanderson, Farquhar.

One hundred Princess, 1st., Esty Bros.; 2nd., Wm. Sim.

One hundred any other single, 1st., Wm. Sim, Boston; 2nd., H. F. Woods, No. 7.

James Wheeler Trophy for best New Violet, 200 blooms, silver cup, Wm. Sim, Boston.

Miscellaneous.

Collection of Bulbs, 1st., Mann Bros.

Fifty Lily of the Valley, 1st., H. M. Robinson & Co.

Twenty-five Mignonette, 1st., Wm. Nicholson.

One hundred Pansies, 1st., W. C. Ward, Lilium speciosum, F. T. White.

Collection of pot plants, 1st., Mann Bros.

A certificate of merit and special prize for excellence of cultivation was awarded to W. H. Elliott, whose roses were of remarkable quality.

Exhibit from Music Hall Market Growers, 1st., Albert Batley & Son; 2nd., Wyman & Littlefield.

A first class certificate was awarded to John Marshall, Newport, R. I., for red seedling carnation and honorable mention to Backer & Co., for seedling carnation.

S. J. Reuter, Westery, R. I.; Thos. Roland, Nahant; Elijah A. Wood, West Newton, and A. H. Fewkes, Newton Highlands, officiated as judges.

ROSES FROM SAND ARE "CUTTINGS," NOT "PLANTS."

United States vs. American Express Company.

U. S. Circuit Court of Appeals, Second Circuit, February 11, 1908. (No. 124 suit 1800.)

Rose Cuttings—Plants.

Rose cuttings that have been put in sand in preparation for shipment, but have never in fact been in soil, are not dutiable as "rose plants" under paragraph 252, tariff act of 1897, but as cuttings of * * * shrubs, plants * * * commonly known as nursery or greenhouse stock," under the same paragraph.

Appeal from the Circuit Court of the United States for the Western District of New York.

(Decision adverse to the Government.)

For decision below see T. D. 28206, in which the circuit court affirmed a decision of the Board of United States General Appraisers, reported as Abstract 9655 (T. D. 26997), which had sustained the importers' protest against the assessment of duty by the collector of customs at the port of Buffalo.

The import in dispute consisted of rose cuttings that had been put in sand in preparation for shipment but had never in fact been in soil. The Government contended that the Board and the circuit court had erred in holding them dutiable under the provision in paragraph 252, tariff act of 1897, for "cuttings of * * * shrubs, plants, * * * commonly known as nursery or greenhouse stock," and that they had been properly classified by the collector under the provision in the same paragraph for "rose plants."

Lyman M. Bass, United States attorney, for the United States.

Before Lacombe, Coxe, and Ward, Circuit Judges.

Per Curiam: Judgment affirmed.

HORTICULTURE

VOL. VII

MARCH 7, 1908

NO. 10

PUBLISHED WEEKLY BY
HORTICULTURE PUBLISHING CO.
 11 Hamilton Place, Boston, Mass.

Telephone, Oxford 292
 WM. J. STEWART, Editor and Manager

SUBSCRIPTION PRICE

One Year, in advance, \$1.00; To Foreign Countries, 2.00; To Canada, \$1.50

ADVERTISING RATES

Per Inch, 30 inches to page \$1.00.
 Discounts on Contracts for consecutive insertions, as follows:
 One month (4 times) 5 per cent.; three months (13 times) 10 per cent.;
 six months (26 times) 20 per cent.; one year (52 times) 30 per cent.
 Page and half page spaces, special rates on application.

Entered as second-class matter December 8, 1904, at the Post Office at Boston, Mass.
 under the Act of Congress of March 3, 1879.

CONTENTS

	Page
FRONTISPIECE— <i>Pyrus floribunda</i>	
FLOWERING APPLES—Daniel A. Clarke—Illustrated	293
MARKET EXHIBITION AT BOSTON.....	295
AFTER ADJOURNMENT.....	297
OBITUARY—C. N. Nesmith—Fred. C. Miller—John A. Freeman—Ewald Suder—Lewis D. Robinson.....	297
NEWS OF THE CLUBS AND SOCIETIES	
Connecticut Horticultural Society—Newport Horti- cultural Society—Illinois State Horticultural Society.....	298
New York Florists' Club—Tarrytown Horticultural Society—Massachusetts Horticultural Society....	299
Huntington Horticultural and Agricultural Society —Florists' Club of Philadelphia—Twin Cities Florists' and Gardeners' Club—Society of American Florists—Club and Society Notes.....	300
SEED TRADE.....	302
Catalogues Received.....	302
OF INTEREST TO RETAIL FLORISTS	
A Well Made Wreath—Illustrated.....	306
Washington—Chicago—New Retail Flower Stores	307
FLOWER MARKET REPORTS	
Boston, Buffalo, Chicago, Indianapolis, New York, Philadelphia, Washington, Twin Cities.....	309
MISCELLANEOUS	
Roses from Sand are Cuttings, not Plants.....	295
Lilies Shy of Bloom.....	297
Personal.....	297
Rose Party from Philadelphia to Chicago.....	297
News Notes.....	297, 302, 306, 317
Plant Imports.....	302
Philadelphia Notes.....	306
Incorporated.....	309
Business Changes.....	309
An Orchid Society Proposed.....	317
Greenhouses Building or Contemplated.....	318
List of Patents.....	318
Fire Record.....	318

The single violet a winner

"Slowly but surely" the single flowered varieties of the violet are winning the popular preference and the once regal Marie Louise and other double forms are being obliged to give way to the Princess and Boston with their strong-stemmed, pansy-like flowers which, in classic Boston, have already held the

precedence for several years but which until recently have failed of appreciation in most of the other large flower-buying communities. In fragrance these single varieties far outclass their double-flowered cousins and under wise culture their strength, vigor and general health and adaptability will surely win the day for them especially with growers who have found Marie Louise unmanageable. We look to see the single varieties increase in popularity with each passing season and beyond a doubt, this means the solution of the problem of a local violet supply in many places which hitherto have been compelled to get their supply from remote sources.

Robert Craig's paper on the "Private Gardener," which appears in this issue will be read with interest, and also with much profit, by many who know

that anything Mr. Craig has to say is always worth listening to and worth recording. In this valuable address he views the gardener as he is, the gardener as he might be if he is to attain to the full possibilities of his vocation in the future. To reach the standard set by Mr. Craig the aspiring young gardener will find his time and mind well occupied and little opportunity for frivolous pastimes. It means hard work, mentally and physically, and much self-sacrifice at times but the course once adopted and diligently pursued will soon become almost second nature and its exactions will be a delight at each step of advancement. Unpromising, indeed is the outlook for the gardener who will draw no inspiration from Mr. Craig's words. Thoughtful, logical, sympathetic and far-seeing, they should serve as an incentive and encouragement to every gardener who would "look up and not down," with a courageous determination to win for himself a position of honor in the history of his profession.

Where education points the way

It is especially worth remembering that Mr. Craig's counsel is equally applicable to the gardener bent upon a commercial career as to him

whose preference is for a position in a private capacity. It has often been shown that the most intelligent and successful of our commercial florists and nurserymen have usually come from the ranks of the "private" gardeners, a fact which is due to the greater facilities enjoyed by the man in a private position to study and acquire experience and ripe judgment on broad lines and further to the perseverance and patience with which these men have taken advantage of such opportunity. Education is the best prerequisite for success and that this will become more and more indispensable in the immediate future must be apparent to all who will give the subject serious thought. In our last issue we took the liberty to call attention to the desperate odds against the antiquated greenhouse under the present conditions and prospects in commercial flower and plant growing. Let us now in like manner warn the gardener and florist if he, himself, be indifferent to the progress going on all around him, of the still greater handicap he will now have to carry, crippled and unfitted to compete with the well-informed and progressive rival who has taken advantage of the grand opportunities for self-help which are now at his disposal and which Mr. Craig has so earnestly and convincingly called attention to.

AFTER ADJOURNMENT.

Last week we mentioned Shamrocks in this column. Let us add to the list of enterprising dealers in the "rale thing," Leonard Cousins, Jr., whose advertisement appears in this issue. Samples of this stock were shown at the Market Exhibition and they are little beauties.

Carnation Winsor.—Your correspondent, "E. J.," on page 50, raises a question as to the correct spelling of the name of this Carnation; but perhaps he will tell us whether it is named after a man or woman, or after a town or district. In the former case it is quite probable that it is correct to spell it without the letter d; but if it is named after a town, village or district, which itself would in all probability be named after our own royal town of Windsor, then surely we are justified in spelling it thus. This mutilation of the English language by Americans reminds one of the schoolboy who proceeded to show his father how to plough, although the latter had been at ploughing more or less for well nigh half a century.—Anglian, in "The Garden," London.

We clip the above from the columns of our British contemporary. "Anglian" is respectfully informed that carnation Winsor is named for a gentleman who, undoubtedly, knows how to spell his own name, so "this mutilation of the English language by Americans" need cause no further loss of sleep to our distressed friend across the water. This superb carnation, we might add, has a royalty of its own, to which the "mutilation" of its name by the insertion of a "d" could not add a farthing's worth.

LILIES SHY OF BLOOM.

I am having the very deuce of an experience with my Easter lilies this year. They have been handled as usual, but at this date they are not over 18 inches; some not more than a foot high, and each plant is showing one measly bloom. I have been growing *Harrisii* for ten years but never saw anything like this. Can you explain the phenomenon? I wanted to have them show buds about middle of this month, but I wanted more than one to a plant. Answer in next issue, and oblige,
F. M.

Our correspondent fails to state the size of the bulbs in question. If 6 to 8 in. they should ordinarily produce from two to five flowers each; if 7 to 9 in. they should give from three to eight flowers; 18 inches is a fair, normal height at this date. If a little higher temperature is given, with slight ventilation, the height of the stems may be increased. One flower to a bulb is a very poor showing and is inexplicable unless the bulbs are unusually small or are of a degenerate variety.

A BURGLARY AT WEST GROVE, PA.

Burglars visited the West Grove post office on the 3rd inst. Among other things carried off was a bag of registered letters. This bag contained many orders for the Dingee & Conard Co. and the Conard & Jones Co. Those of our readers who have sent orders or money to either of these firms recently should write at once.

PERSONAL.

Visitors in Chicago: C. S. Ford, Philadelphia, Pa.; R. J. Mohr, Racine, Wis.

Visitors in New York: Wm. Jurgens, Newport, R. I., en route for Washington, D. C.; C. C. Cropp, Chicago.

James T. Quinn, florist of Brookline, Mass., is a candidate for the office of selectman of that town.

Thomas Logan, superintendent of the Newbold estate at Jenkintown, Pa., is happily recovering from his recent severe illness.

Mark Aitken, of Springfield, Mass., who has been ill with pneumonia, has so far recovered as to take a trip to Bermuda. He sailed on the 22d ult.

U. G. Scollay, of the firm of J. A. Scollay, Brooklyn, N. Y., has been re-elected treasurer of the American Society of Heating and Ventilating Engineers.

Frederick W. Kelsey, president of the American Nursery Co., New York, was among the guests who occupied the first official train that passed through the Hudson River tunnel on February 25. Mr. Kelsey also was a guest at the banquet at Sherry's that followed in the evening.

A. Hans, for many years superintendent at the Palmer Estate, Stamford, Conn., will on April 1 remove to Locust Valley, Long Island, where he will have charge of the Hodenpyl estate. Mr. Hans is well known to the readers of HORTICULTURE through his interesting contributions to our columns on Ferns and on Conifers, on both of which subjects he is a recognized authority.

Visitors in Boston: Robert Craig, W. P. Craig and J. S. Hay of Philadelphia; Winfried Rolker, Chas. Loehner of New York; H. Suzuki of Yokohama, Japan; S. J. Reuter, Westerly, R. I.; John Marshall, Newport, R. I.; Alex. Wallace, Portland, Me.; Chas. S. Strout, Biddeford, Me.; H. A. Jahn, New Bedford; Jos. Fuller, Leominster, Mass.; Thos. Knight, of Knight & Struck, New York; John Brown, Bar Harbor, Me.; J. C. Hillebrand, Hillegom, Holland; W. W. Matthews, Great Neck, N. Y.; G. A. Drew, Greenwich, Conn.; A. J. Pieters, Hollister, Cal.; James McGregor, Manchester, Mass.; Mr. and Mrs. C. H. Maynard, Detroit, Mich.

ROSE PARTY FROM PHILADELPHIA TO CHICAGO.

Those from the vicinity of Philadelphia intending to go to the rose convention in Chicago on the 25th, should communicate with Adolph Farenwald, Roslyn, Pa. He is endeavoring to get up a party so as to secure the reduced rates.

OBITUARY.

C. N. Nesmith.

C. N. Nesmith, a successful rose grower of Plympton, Mass., died on February 20.

Fred C. Miller.

Fred C. Miller, florist, and for many years a prominent figure in municipal affairs, died at his home in Bracondale, Ontario, on February 24.

John A. Freeman.

John A. Freeman, who for the past fifteen years has carried on a large greenhouse business at 376 N. Lake street, Aurora, Ill., died on February 18, in his fifty-fourth year.

Ewald Suder.

Ewald Suder, son of Mrs. Henrietta Suder, a prominent florist of Toledo, O., took his own life on February 24, while in a fit of despondency due to ill health. He was 37 years of age, unmarried. His mother, a brother and a sister survive him.

Lewis D. Robinson.

Lewis D. Robinson, who of late has been associated with his son in the florist business, died at his home in Springfield, Mass., on February 26. Mr. Robinson was one of the founders of the Amateur Horticultural Society and a vice-president of the Hampden County Horticultural Society, and has filled various offices of trust in the city. A widow, a son and a daughter survive him.

NEWS NOTES.

At the alumni dinner of the Massachusetts Agricultural College at Northampton on February 21, President Butterfield emphasized the need of a new greenhouse, which has been included in their legislative budget this year for the fourth time.

Through the philanthropy of one of its pioneer citizens, Col. J. T. Munson, Denison, Texas, is to have another and one of the largest parks in the South. Col. Munson recently deeded 130 acres of valuable land to the city for park purposes. Denison has been keeping well to the front in the march of progress and civic improvement and this generous gift adds distinction.

The Denison (Texas) Civic Improvement League, an organization which has been doing very effective work for the betterment of Denison during the past two years, conducted a very successful tree-planting campaign, which resulted in the planting of many shade trees and hardy shrubs on Arbor Day. The school children of the city planted over seven hundred trees and shrubs on the school grounds, along the streets and in home-yards, the plants being distributed last year, and it is expected that more than double this quantity will be required this year.

FORMOSA

LILIUM LONGIFLORUM

Ask your dealer for our own special grown stock or write us direct for quotations. Only a limited quantity available for the coming season 1908 Delivery will be made the first part of August. The bulbs are thoroughly ripened one month before the Bermuda Harrisii and are considered far superior in quality as they are *entirely free from disease*.

Careful trials were made for two years and were so successful that we imported over 300 cases last season. Our cases will be marked Y. N. Co.

**Orders for this Season Must Be in Our
Hands by MARCH 15.**

YOKOHAMA NURSERY CO., Ltd., 31 Barclay Street, NEW YORK

NEWS OF THE CLUBS AND SOCIETIES.

CONNECTICUT HORTICULTURAL SOCIETY.

The meeting of this society was held in County Building, Hartford, on February 28, President Huss in the chair. It was cyclamen night and the attendance was unusually large, about thirty-five members being present. Pres. Huss named Messrs. Sierman, Vidbourne and Gerard as judges, and the awards were as follows:

Certificates of merit to C. Peterson for two specimen cyclamen plants; J. F. Huss for six varieties cyclamen and *Cineraria stellata*; A. J. Weber, for *Cineraria stellata*; diploma to P. Zuger, six specimen plants of *Primula obconica*. W. N. Shumway of Berlin exhibited for the first time a seedling carnation of the Enchantress type, color deep pink. He has grown this carnation for five years, and says it is practically a non-splitter; a strong grower, and equally as prolific as its parent. A special judging committee awarded this promising variety a certificate of merit. F. Roulier read an excellent paper on cyclamen culture. Mr. Roulier is one of our most successful cyclamen growers, and the skilful way in which he treated his subject was heartily applauded. The paper was followed by a lively discussion on the advisability of saving old bulbs. The general opinion was that while an occasional specimen plant could be produced from a bulb, the most profitable way would be to grow them annually

from seed. G. W. Smith was appointed delegate to attend the convention of the Massachusetts Fruit Growers' Association, March 11 and 12, at Worcester, Mass.

ALEX CUMMING, JR., Sec.

NEWPORT HORTICULTURAL SOCIETY.

A largely attended meeting of this society was held Tuesday evening last. James Robertson occupied the chair in the unavoidable absence of President Allan. Robert Cameron read a paper on "Annuals and Biennials," which proved very interesting and full of facts well worth knowing, told in such a way that even to those who may have been aware of many of them, there was a freshness that pleased and instructed. The paper was carefully prepared, evidently with the view of disarming criticism; it was well received and favorably commented upon and Mr. Cameron was awarded the thanks of the society at its conclusion.

There were on exhibition a number of seedling carnations from John Marshall. James J. Sullivan, Stewart Ritchie and Bruce Butterson, as judges, recommended that the society's silver medal be awarded to Mr. Marshall for a red seedling named Newport, and a certificate of merit for a white, and the recommendations were adopted. Newport is good in color, substance of flower and length and strength of stem. Mr. John Peaton accompanied Mr. Cameron.

ILLINOIS STATE HORTICULTURAL SOCIETY.

We have received a copy of the transactions of the Illinois State Horticultural Society for 1907 which shows, in its contents, that this organization is doing spirited work and endeavoring to fulfil its mission for the practical advancement of horticulture in its jurisdiction.

Besides the papers and discussions at the 1907 annual meeting of the State Horticultural Society the book contains the proceedings of the meetings of the Northern, Central and Southern Illinois Societies for 1907, and much other information of practical value. The papers on "Problems in Co-operative Marketing," by J. B. Graves, of Missouri, and "Forestry for Illinois," by Prof. T. J. Burrill, of the University of Illinois, are of especial interest just now. The book contains a fine portrait of the late Edgar Sanders.

Any person paying one dollar may become an annual member of the Society and receive a copy of this book postpaid. Upon application copies of the book will be furnished school and other libraries of the State, and to local Horticultural Societies. Applicants are expected to pay express charges or send stamps to cover postage.

All communications should be addressed to W. B. Lloyd, Secretary, Kimmndy, Ill.

WATERER'S RHODODENDRONS

CONIFERS, LAURELS, SPECIMEN ORNAMENTALS

FAMED
ALL
OVER
THE
WORLD



SPECIAL
FOR
AMER-
ICAN
TRADE

Send For List of Varieties. Special Quotations on Quantities. Prompt Shipment and Good Satisfaction

JOHN WATERER & SONS

AMERICAN NURSERIES, - - BAGSHOT, ENGLAND

NEW YORK FLORISTS' CLUB.

The annual banquet of this club took place on Saturday evening, Feb. 29, at the St. Denis Hotel, with the usual attendance. The tables were beautifully decorated with choice flowers, donated by the club members, and the affair was very much enjoyed by those present, although, perhaps, in a more subdued and sedate vein than on some former occasions. It was the 21st anniversary, and many letters of regret at inability to be present were received.

When the time for talking had arrived, President Weathered addressed the banqueters, bidding them welcome and dilating upon the club's proud record of usefulness. Ex-President Chas. H. Totty followed, speaking for the toast, "Our Night." He expatiated enthusiastically and hopefully on the outlook for the next twenty years in the history of the club when, he believed, the membership would be no less than one thousand.

The Society of American Florists and Ornamental Horticulturists was responded for by President F. H. Traendly, who urged the importance of loyalty to the national organization and participation in the great exhibition to be held by the society next fall in Chicago. President Weathered spoke of the wonderful engineering accomplishments in the completion of the "tubes" connecting New York and New Jersey and Long Island, which he believed would result in bringing in many new club members from a radius of 75 miles and tend to bring about the long-cherished ambition for a club "Home."

"The Horticultural Press" was assigned to J. Austin Shaw, who did credit to his topic in his usual eloquent and graceful manner. He urged the need for a "press" devoted to the welfare of all departments untrammelled by individual prejudices or business interests, and quoted from some verses read by him five years ago.

Then came the presentation of a beautiful diamond scarf pin to Ex-President Totty on behalf of the club members, R. M. Schultz officiating and making one of the best of his many merry speeches. Mr. Totty's response was eloquent also and expressive of his heartfelt appreciation of the gift.

E. V. Hallock responded in interesting and happy vein for "Our Sister Societies," and gave the horticulturist due credit for being a companionable, good fellow wherever and whenever he is found. Best of all the sister societies, he said, was the S. A. F.

A "silent toast" was drunk standing, to the memory of those who had passed away during the year. A unanimous vote of thanks was passed to the dinner committee, and at midnight adjournment came. During the evening, songs, stories and recitations were interspersed between the speeches by excellent vaudeville performers.

TARRYTOWN HORTICULTURAL SOCIETY.

The regular monthly meeting of the T. H. S. was held on Friday evening, February 28. The Executive Committee reported the following dates for

the annual exhibitions: Summer Show, June 11; Fall Show, November 4, 5, 6. An invitation was read from the Monmouth County Horticultural Society to attend their fourth annual dinner at Red Bank, N. J., on March 3. Wm. Scott offered a prize for 12 cut roses, but roses must be off crop around here; the only roses on the table were from Robert Scott & Sons, Sharon Hill, Pa., who sent their new rose, "Mrs. Jardine" which, after a severe and critical discussion, was awarded a certificate of merit. Rose growing under glass was the subject for the evening; the discussion was opened by Mr. Joe Mooney and followed by many members. Next meeting will be "Cyclamens."

L. A. MARTIN, Cor. Sec'y

MASSACHUSETTS HORTICULTURAL SOCIETY.

On Saturday, February 29, Robert Craig, of Philadelphia, read a paper at Horticultural Hall, Boston, before an appreciative audience on the subject of "The Private Gardener." The paper will be found on another page of this issue. At its close, Mr. Craig was asked a few questions, among them being one in regard to the culture of gardenias. These flowers, he said, were of the easiest culture in the summer, flowering freely and profusely under ordinary treatment but the production of flowers in winter is a much more difficult problem. A temperature of 65 degrees, carefully maintained, with the avoidance of any sudden check, are among the requisites. For summer flowering the young plants should be kept over from fall until



And the Sale Was Still There

TUESDAY, MARCH 17, at NOON, we will inaugurate the Season of 1908, (St. Patrick's Day) by holding our

FIRST SALE

of ROSES, CONIFERS, BULBS, ROOTS, Etc., at

W. ELLIOTT & SONS, 201 Fulton St., NEW YORK

about May 1, in 4-inch pots in dormant condition.

W. N. Craig, of North Easton, added a few words. He said that the successful gardener of the future must know many things thoroughly besides horticulture. He must understand plumbing, gas and steam fitting, must be qualified to purchase coal, machinery and agricultural supplies and have a good knowledge of botany, chemistry, etc. He should acquire familiarity with old-fashioned hardy plants and shrubs and, if filling his position satisfactorily, the question of salary will take care of itself. His course should be to think more about the character of his work than the amount of his pay. On the exhibition table were some interesting plants from R. & J. Farquhar & Co., including the new rambler rose Tausendschon whose wide expanded soft pink blossoms and rich fragrance were favorably commented upon, and two handsome hippeastrum seedlings grown in Porto Rico by James Farquhar. One of these, named Triumph, bore a remarkably well-formed and massive flower of great brilliancy.

HUNTINGTON (N. Y.) HORTICULTURAL AND AGRICULTURAL SOCIETY.

The fourth annual carnation exhibition of the Huntington H. & A. S. was held on February 25. There were numerous entries in the different carnation classes and the quality was quite up to former standards. The display of flowering and ornamental plants, and bulbous and other spring flowers, made a very fine show on the second floor. Not the least encouraging feature was an increased interest by the public as was shown by the attendance. The judges were Samuel Riddell of Farmingdale and Henry Weston of Hempstead, L. I.

Awards were as follows:—25 Lawson; H. T. & A. H. Funnell, Huntington, 1st; Chas. Weber, Lynbrook, 2d. 25 Enchantress; Kramer Bros., Farmingdale, 1st; White Bros., Gasport, 2d. 25 White; Chas. Weber, 1st with White Perfection; H. T. & A. H. Funnell, 2d, with same. 25 Scarlet; Henry Weston, Hempstead, 1st with Victory; White Bros. 2d, with Beacon. 25 Any Other Color; Chas. Weber, 1st with Imperial; H. T. & A. H. Funnell, 2d with Winsor. 25 Assorted; August Heckscher, Adolph Alius, gardener, 1st; Walter Jennings, Richard Cartwright, gar-

dener, 2d. 12 Roses; A. Heckscher, 1st. 100 Violets, double; W. Jennings, 1st; H. T. & A. H. Funnell, 2d. 100 Violets, single; W. Jennings, 1st; W. J. Matheson, Jas. Kirby, gardener, 2d. 25 Freesias; Riddell & Herrick, Farmingdale, 1st; H. T. & A. H. Funnell, 2d. 25 Sweet Peas; H. E. Hyde, Centreport, 1st; Kramer Bros., 2d. 12 Mignonette; A. Heckscher, 1st. Blooming Plant; A. Heckscher, 1st; W. Jennings, 2d. Foliage Plant; A. Heckscher, 1st; H. T. & A. H. Funnell, 2d. Spring Bulbous or Other Flowers; W. Jennings, 1st; A. Heckscher, 2d. Greenhouse Vegetables; A. Heckscher, 1st; W. Jennings, 2d.

A. H. FUNNELL, Sec'y.

FLORISTS' CLUB OF PHILADELPHIA.

Manda's pink seedling carnation "No. 20," and Dreer's "Blush Queen Alexandra" Marguerite, were the only exhibits at the monthly meeting of this club held on the 3rd inst. J. Otto Thilow gave an entertaining account of a recent trip to Europe, which was so good that we hope to publish same in full at an early date. A characteristic letter from A. McConnell of New York was introduced in the middle of the speaker's talk and created much merriment. A dinner will occur on the 11th inst. under the auspices of the club. This takes the place of the usual "smoker" given about this season of the year. Robert Craig gave an interesting account of his visit to Boston last week. What impressed him most was the extraordinary Killarney's the Boston people produce and the unique way in which William Sim grows sweet peas and violets. Thomas Roland's success with the Canterbury Bell as an Easter pot plant was also favorably commented on.

TWIN CITIES FLORISTS' AND GARDENERS' CLUB.

The Twin Cities Florists' and Gardeners' Club held its first field meeting on February 26. About 40 members responded to an invitation from the L. L. May Co. in St. Paul to inspect their new seed and greenhouses. A committee appointed at the last meeting to meet the executive committee of the Minnesota State Fair reported that there will be more prizes for horticultural exhibits this year and more space for display. The time is not far off when the horticulturists of the State will be given a large building for their

displays at the Fair Grounds. The Minnesota State Fair is known all over the country as one of the largest and best.

Will Brothers, Minneapolis, exhibited at the last club meeting quite a few Winsor carnations. They have had good success with it and intend to grow Winsor on a large scale next season.

SOCIETY OF AMERICAN FLORISTS AND ORNAMENTAL HORTICULTURISTS.

A meeting of the executive board of the S. A. F. & O. H. is called by order of President Traendly, to be held at the Prospect House, Niagara Falls, New York, at 9 o'clock A. M. on March 23d next. The same is to continue on March 24th in case the business affairs of the Association are not concluded previously.

W. N. RUDD, Sec.

NATIONAL FLOWER SHOW.

Mr. W. Wells of Merstham, England, offers for the exhibition at Chicago in November next, a gold, a silver and a bronze medal for six blooms of chrysanthemum W. M. Moir, to be shown on stems 30 inches long.

Notice of this offer having arrived too late to be included in the first edition of the premium list, it is hereby given.

W. N. RUDD, Chairman.

CLUB AND SOCIETY NOTES.

The Alabama Horticultural Society at their recent annual meeting re-elected W. F. Heikes of Huntsville, Ala., as president.

The Worcester County Horticultural Society, Worcester, Mass., will hold its annual reunion and banquet at its hall on March 11 at 6:30 p. m.

The spring show of the St. Louis Horticultural Society will be held March 10-12 in the banquet hall of the Grand Avenue Masonic Temple.

John T. Withers of Jersey City is to deliver a series of lectures in Minneapolis, Minn., beginning March 11, on the care and maintenance of trees.

The Columbus (O.) Florists' Club organized a bowling club recently with Jacob Reichert, captain; Wm. Metzmaier, secretary, and Jas. McKellar, treasurer.

Prof. H. S. Jackson, Newark, Del.,

**Wholesale
Only**

Recent Genuine Novelties in

SWEET PEAS

The following are our recent introductions in the **Giant Flowered Wavy Standard Varieties**. These have all been sent out **well fixed in character**, and can easily be kept so:—

- GLADYS UNWIN**—Lovely pale pink. A great market favorite.
- NORA UNWIN**—The purest and finest giant flowered white.
- PHYLLIS UNWIN**—A deep rosy carmine self, and sunproof.
- A. J. COOK**—Best described as a **giant flowered Mrs. Walter Wright**.
- FRANK DOLBY**—Lovely pale blue, a **giant flowered Lady Grisel Hamilton**.
- MRS. ALFRED WATKINS**—A lovely delicate pale pink with pale salmon shading.
- E. J. CASTLE**—Rich carmine with salmon shading. The finest of all for artificial light.

These are all the **Giant Flowered Offsprings** of "Gladys Unwin."

ALSO **EVELYN BYATT**—Rich flame color. The first of this rich color.

To be had from all Seedsmen and Nurserymen throughout the United Kingdom, America and the Colonies.

WHOLESALE ONLY FROM

WATKINS & SIMPSON,

Wholesale Seed Merchants
and Growers,

12, Tavistock St., Covent Garden, LONDON, W. C., England

will deliver the lecture before the Massachusetts Horticultural Society on March 14: subject, Development of disease resistant varieties of plants. March 21 is the date of the spring flower show.

The Massachusetts Fruit Growers' Association will hold their fourteenth annual meeting at Worcester March 11-12. Prof. H. T. Fernald will speak on insect pests; Jno. Eames and Monroe Morse will discuss fungous pests of the past season; J. H. Hale will compare peach growing in New England with other sections; J. H. Putnam will show the possibilities of fruit growing on the hills of the State; Wilfrid Wheeler will speak on small fruits as a money crop, and Prof. F. C. Sears will tell how commercial orcharding can be developed in Massachusetts. Exhibits of fruit will be made.

The committee in charge announces that the annual outing of the New York Florists' Club will take place on Wednesday, July 1, at Witzel's Grove, per steamer Isabell. All arrangements are completed and Stone's Orchestra are already polishing up their instruments and practicing tunes—Scotch and some German. "Sister Societies" are to be invited to participate. Pretty good work, this. The committee capable of such "previousness" should have their names in type, so here they are: W. E. Marshall, chairman; J. Austin Shaw, secretary; Chas. Schenck, treasurer; Robert Schultz and Jos. A. Manda, sergeants-at-arms; Messrs. Bunyard, Rickards, Fenrich, Hoffmeier, Kessler, Guttman, Wheeler, Berry, Totty, Donaldson.

SUCCESS REWARDED BY SUCCESS—THE UNPRECEDENTED

sale of **High Class Aster** seed more fully demonstrates the fact that cut flower growers of the **better classes**, as well as the **retail florists** from all parts of the **United States** and **Canada**, also **Europe**, are open to **conviction** that the trade demands a **higher** and **better grade** and **quality** of **Astera** than has heretofore been produced, consequently our **improved chrysanthemum type of Aster Lady Roosevelt** seed is in **wonderful demand**, and not only the seed, but also the **cut flower product** from this **unsurpassed improved variety of Aster** as same are being **contracted for** already for next **September delivery** by **retail florists** from several **large cities** of various parts of the **United States**, viz: **New York, Pittsburg, New Orleans, Denver, &c.**, a **\$1.00 per dozen, net**. As we are able to produce this **superior Aster Lady Roosevelt** by our **special improved Scientific Intense Culture Methods** with bloom stems **36 in.** or more in length enables us to ship the cut flower product to any city in the **United States east of Denver** without deterioration, as with the **large, long, stiff, wiry stems** they also **absorb** a large quantity of water before shipping, which **preserves them in transit**, and also **two or three weeks** after their arrival at their destination.

Marvelous as it may seem, we are expecting this season to **improve upon our last seasons accomplishments** by growing our **Aster plants 6 feet tall**, whereas last season they were only **4½ and 5 feet** in height, thereby producing bloom stems **36 to 48 inches** in length with flowers **4½ to 5½ inches** in diameter, thus enabling us to realize **net \$4 000 or more, from the 1¼ acre** that we intend to grow for the cut flower trade. These will be marketed in at least **40** and **possible 60 different cities** in the **United States**, from **Boston, Mass., to Denver, inclusive**. This is our proposed plan for creating a demand and sale for our **unparalleled chrysanthemum type of Aster, Lady Roosevelt**, for those who may in the near future become producers of this **special Aster** from the seed they are now purchasing from us. **FOR** still further **desired information** send for our **illustrated folder**—which also contains other very **interesting information** relative to other **April crops** we are engaged in the culture of.

CHARLES A. KIBBE,
THE SCIENTIFIC INTENSE CULTURE RANCH, ELMHURST, ILL., Box 344.

The Annual Rose Number

Will Be Issued March 21.

This Number will contain many features in connection with the Meeting and Exhibition of the American Rose Society and will be of Special Interest to Rose Growers.

Send Advertising Copy Now

Seed Trade

A new store is soon to be opened by M. Lytle at Clear Lake, Iowa.

David Lawton, Racine, Wis., is succeeded by Olley & Osborne.

CATALOGUES RECEIVED.

Ross Bros., Wichita, Kansas. Seed Catalogue for 1908. Agricultural and garden seeds and implements.

S. J. McMichael, Findlay, Ohio.—Wholesale Trade List of Vegetable, Greenhouse and Bedding Plants.

Benjamin Hammond, Fishkill-on-Hudson, N. Y.—Catalogue of colors, putty, insecticides and chemicals.

Wagner Park Conservatories, Sidney, Ohio.—Fine Nursery Stock for Landscape Effects. Interesting and well-illustrated.

Charles F. Saul, Syracuse, N. Y.—List of Select Seeds, Implements and Poultry Supplies.—A substantial catalogue of well-tested varieties.

A. Lenthy & Company, Roslindale, Mass.—Wholesale Price List of Palms, Ferns and Decorative Plants. Not an extensive list but includes the best of the standard trade material.

Eastern Nurseries, Jamaica Plain, Mass., M. M. Dawson, Mgr.—Wholesale Trade List for Spring, 1908. A very choice list including many varieties usually hard to find in nursery offers.

F. & F. Nurseries, Springfield, N. J.—Trade List for Spring, 1908. The extensive nursery issuing this concise wholesale list is now a department of the American Nursery Co., with central office at New York City.

Thomas Meehan & Sons, Inc., Germantown, Philadelphia, Pa.—Meehan's Manual of Outdoor Plants, Spring, 1908, 46th Edition. The best hardy shrubs, trees and border plants are well presented in this elegantly arranged catalogue.

Bay State Nurseries, W. H. Wyman, North Abington, Mass.—Wholesale List of Trees, Evergreens, Vines, Roses and Herbaceous Perennials for Spring, 1908. A very comprehensive catalogue, particularly strong on phloxes, peonies, irises and hardy roses.

Ellwanger & Barry, Rochester, N. Y.—General Catalogue of Mt. Hope Nurseries, established 1840. As interesting as ever and still one of the best in contents and arrangement. Some splendid half-tone illustrations are shown for first time. Accompanying the catalogue is a pamphlet entitled "How to Have Roses," compiled from contributions to the Country Gentle-

A NEW STRAWBERRY

We have been growing and selling Strawberry Plants in this town over THIRTY YEARS. We introduced Brandywine, Kattie Rice, Sen. Dunlap, Wm. Belt and others of value. Now we are bringing out

THE HIGHLAND

which we expect to take the lead as a Money-Maker. Let us tell you about it and forty others. It will cost you but a postal card.
M. CRAWFORD & CO., Box 1020, Cuyahoga Falls, Ohio

Michell's Reliable Aster Seeds

QUEEN OF THE MARKET MICHELL'S IMP. SEMPLES BRANCHING

	Tr. pkt.	Oz.		Tr. pkt.	Oz.
CRIMSON.....	\$.20	\$0.60	CRIMSON.....	\$0.40	\$1.50
DARK BLUE.....	.20	.60	LAVENDER.....	.40	1.50
LIGHT ".....	.20	.60	ROSE PINK.....	.40	1.50
PINK.....	.20	.60	MIXED.....	.40	1.50
WHITE.....	.20	.60	SHELL PINK.....	.40	1.50
MIXED.....	.20	.60	PURPLE.....	.40	1.50
			WHITE.....	.40	1.50

Formosa Lil. Longiflorum Bulbs. Stock Limited. Order Quick.

Our Catalogue for Florists Now Ready
HENRY F. MICHELL CO., 1016 Market St., Philadelphia

man by Wm. C. Barry. Rose lovers should read it.

PLANT IMPORTS.

There were entered at the port of New York during the two weeks, Feb. 19 to March 2, inclusive, the following goods:

Via Rotterdam: H. F. Darrow, 67 cs. plants; Wm. Elliott & Sons, 3 cs. do.; McHutchison & Co., 206 cs. do.; Maltus & Ware 167 cs. do.; 8 cs. trees, 3 cs. bulbs; 25 cs. roots; W. A. Mando, 4 cs. plants and bulbs; P. Ouwerkerk, 21 cs. trees; J. M. Thorburn & Co., 3 bls. seed; Stumpp & Walter Co., 13 cs. flower roots; Weeber & Don, 1 bale seed; Sundry Forwarder, 19 cs. plants, 39 pgs. do., 10 cs. seed.

Via Antwerp: Forwarders, 5 cs. trees, 2 cs. hulbs.

Via Havre: C. C. Abel & Co., 35 pgs. plants; P. Henderson & Co., 27 pgs. seed; Forwarders, 34 pgs. wine plants 19 pgs. plants; J. M. Thorburn & Co., 20 pgs. seed.

From Germany: H. F. Darrow, 81 pgs. lily of the valley pips; P. Henderson & Co., 12 bgs. seed; J. M. Thorburn & Co., 1 cs. do.; Stumpp & Walter Co., 12 pgs. do.; Vaughan's Seed Store, 2 pgs. do.; Forwarders, 8 cs. lily of the valley pips; 14 cs. seed.

Via Southampton: C. C. Abel & Co., 36 cs. plants; L. Dupuy, 5 cs. do.; H. F. Darrow, 17 pgs. seed; McHutchison & Co., 60 cs. plants, 92 cs. trees and plants; A. Rolker & Sons, 29 cs. plants; A. Patterson, 19 cs. trees.

Via Liverpool: H. Darrow, 7 cs. trees; Forwarders, 7 cs. do.; 4 pgs. seed.

From London: P. Henderson & Co., 63 sks. peas, 1 cs. seed.

NEWS NOTES.

Wm. Elliott & Sons' plant auction sales start for the season at noon on March 17, St. Patrick's Day, at 201 Fulton street, New York. The genial spring warmth which the emerald holiday is presumed to usher in makes it an ideal opening date for this time-honored occasion for which the popular interloctor, W. J. Elliott, has been industriously polishing up his vocal chords for some time back. May he have a numerous and liberal audience.

The Agricultural Guild of the University of Chicago has been formed. Its aim is "to supplement without duplicating the work of the agricultural

colleges by giving the practical training which their limited equipment and different purpose prevent them from providing." At first ten farms will be included in the plan, each highly specialized, and students will be transferred from one to another. A three years' course of training is planned. Students are recompensed for their service and a satisfactory completion of the course is rewarded with a diploma and \$200.

SPRAY YOUR

FRUIT TREES WITH TARGET BRAND

Guaranteed Sure Death to

SCALE

1 Cal. to 40 Cals. Water, \$1.00

W. ELLIOTT & SONS
201 Fulton St. New York

GLADIOLI

I can satisfactorily supply your wants for Gladioli for forcing or outdoor planting. Mixtures, color sections or named varieties of exceptional beauty.

Write for Prices

ARTHUR COWEE

Gladiolus Specialist

Meadowvale Farm, BERLIN, N. Y.

HYACINTHS, TULIPS, NARCISSI AND OTHER BULBS

ROMAN HYACINTHS and the true PAPER WHITE GRANDIFLORA

Ask for our Wholesale Trade List at Hillegom

K. VELTHUYS, Hillegom, Holland
Rep. by FELIX EOSCH, 260 Clarendon St., Boston.

JUST ARRIVED LARGE SHIPMENT OF High-Grade SCOTCH SOOT.

We have the stott Double Nozzle
THOMAS J. GREY CO.
32 & 33 So. Market St., BOSTON

Quality the First Requisite

FOR OVER SIXTY YEARS WE HAVE SUPPLIED THE PRIVATE AND COMMERCIAL GROWERS

- Giant Cyclamen, best strain and colors, 100 seeds \$1.00, 1000 seeds \$9.00
- Asparagus Plumosus Nanus, 100 seeds 75c, 1000 seeds \$5.00.
- Asparagus Sprengerii, 1000 seeds 75c.
- Cosmos, early White and Pink, 20c trade pkt., \$1.00 oz.
- Tuberose Excelsior Pearl, \$1.00 per 100, \$8.50 per 1000.
- Begonia, single tuberous rooted, in colors, \$3.00 per 100
- Gloxinia, Red, White, Blue and Spotted, \$4.50 per 100.
- Scotch root, Bamboo Canes, etc., etc. Send for catalogue. Wholesale list to trade only.

SCHLÄGEL & FÖTTLER CO.
26-27 So. Market St., Boston, Mass.

WIBOLTT'S SNOWBALL CAULIFLOWER-SEED
No. 34 is the earliest of all Snowballs, the most compact, the surest header, is giving the largest and snow-white heads, and is the best keeper in dry-weather. Demand it through your seed-firm or direct from
R. WIBOLTT, NAKSØV, DENMARK

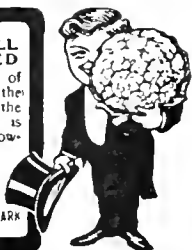

Cyclamen
Superb English Strain Second to none in size of flowers
Giant Crimson.
" Pink
" White.
" White with Claret base.
" Maize.
" Salmon Queen.
" New Fringed.

100 seeds \$1; 1000 seeds \$9.
H. E. FISKE SEED CO.
12 and 13 Faneuil Hall Square, BOSTON MASS.

Vegetable and Flower **SEEDS**
reliable and Tested. Catalogue Mailed Free
WEBER & DON
Seed Merchants 114 CHAMBERS STREET NEW YORK

G. C. MORSE & CO.
Address all communications to our permanent address 48 to 56 Jackson St., San Francisco, Cal.

The Largest Seed Growers in the United States

BRECK'S SEEDS
For Farmer, Market Gardener and Florist
New Crop High Grade
Catalogues mailed free on application

Joseph Breck & Sons Corp.
47-54 NO. MARKET ST., BOSTON, MASS.

CAULIFLOWERS CABBAGE SEED

HJALMAR HARTMANN & CO.,
12 Stormgade, COPENHAGEN, DENMARK.

ASTER SEED

Why not plant the BEST?
We have varieties that are worth the money
We have a \$250.00 prize competition
Our ASTER BOOK is free--it explains

ALTIMO CULTURE CO.
CANFIELD, - - - OHIO

FRANCIS BRILL, Grower and Dealer

Hempstead, Long Island, New York
Choice Seeds for Gardeners, Truckers and Plant Growers. Long Island Cabbage Seed, Cauliflower, Egg, Pepper, Tomato, etc.
Quality Finest Price List Free Wholesale and Retail



COLD STORAGE LILY OF THE VALLEY PIPS
COLD STORAGE LILIUM Harrisii, also SPIRAEA GLADSTONE, LILIUM Auratum, speciosum album, speciosum rubrum, Large Flowering Japan Iris, Cannas, etc.

For prices, state quantities required.

J. M. THORBURN & CO.
33 Barclay St., through to 38 Park Place
NEW YORK

BRIDGEMAN'S SEED WAREHOUSE
RICKARDS BROS.
Props.

37 East 19th St., - NEW YORK CITY

BRASLAN SEED GROWERS CO.
GROWERS FOR THE
WHOLESALE TRADE ONLY
SAN JOSE, - - CALIFORNIA

Burpee's Seeds
PHILADELPHIA

Blue List of Wholesale Prices mailed only to those who plant for profit

BAMBOO CANES TOUGH AND STRONG

6 ft. long—\$1 per 100; \$6 per 1000; \$11 per 2000
They cost about 10 per cent. more than other kinds, and they are 10 times better.
STUMPP & WALTER CO., - 50 Barclay St., New York

RELIABLE SEEDS—SOW NOW

	Tr.	6 Tr.
Alyssum Carpet Queen real dwarf for pots only, no equal....	Pkt.	Pkts.
Begonia Gracilis Luminosa, new	\$0.25	\$1.25
Erfordia, beautiful pink...	0.50	2.50
Lobelia, new Trailing Hamburga	0.50	2.50
Petunia, Double Fringed Giants...	0.30	1.50
Single Fringed Giants...	1.00	5.00
Phlox, best for pots, Fireball, Roseball, Snowball, each color.....	0.75	4.00
Primula Obconica Grandiflora, new Hybrids as: Blood-red, Blue, Carmine, Pink, Purple, Violet, Pure-white, Compacta, Gigantea, Fringed Mixed Hybrids, each separate....	0.25	1.25
	0.50	2.50

My New Price List will guide you through reliable seeds. Ask for same

O. V. ZANCEN
Seedsman. HOBOKEN, N. J.

Best Quality Fall Bulbs

It is to your advantage to place your order early. Send us a list of your wants and we will quote you rock-bottom prices. Copy of our Florists' Bulb Catalogue will be sent upon request. Catalogues now ready.

VICK'S SUPERB PANSY SEED
All the best varieties in separate colors
VICK'S SUPERB MIXTURE
the best strain from all the leading named sorts
1-8 oz. 75c. 1-4 oz. \$1.50 Ounce \$5.00
JAMES VICK'S SONS, Rochester, N. Y.

CYCLAMEN Farquhar's Giant Strain

Unsurpassed for size of flowers.
Giant Crimson Giant Pink
Giant White Finest Mixed
Giant Excelsior, White with Claret Base
100 seeds, \$1 25; 1000 seeds, \$10.00.

R. & J. FARQUHAR & CO.
6 & 7 So. Market St., Boston, Mass.

THE BOSTON VIOLET

The people today are looking for New Violets just as much as they are for new roses or carnations.

THE BOSTON VIOLET

For the past two years has been placed before the most sceptical buyers in America and they prefer it to any other.

THERE'S A REASON

The Boston Violet is the largest, the most fragrant, it has a very pleasing color, and it is a great keeper.

THE BOSTON VIOLET

Is a variety that is early grown, it is the strongest grower and is in crop from September to May.

THE BOSTON VIOLET

Was awarded a First Class Certificate of Merit by the Massachusetts Horticultural Society and a Report of Superior Merit by the Gardeners' and Florists' Club of Boston.

Distribution will Commence in April. Order Now.

PRICES—\$2 per 12 ; \$12 per 100 ; \$100 per 1000.

WILLIAM SIM, : : CLIFTONDALE, MASS.

CHRYSANTHEMUMS

Novelties for 1908, in 2½ inch Pots, Ready for Immediate Shipment

MRS NORMAN DAVIS. Pure white, an improved Mme. Carrot. Best exhibition white out.
DOROTHY GOLDSMITH. Might be called a bronze F. S. Vallis, and easy doer. The finest bronze out.
KATIE PALGRAVE. A clear, waxy white, resembling Mrs. A. T. Miller, but fuller, and two weeks later.
MRS SOUTHGATE. As large as F. S. Vallis, but a brighter yellow.

O. H. BROOMHEAD. An immense, solid bloom, rich deep rose, with sturdy dwarf habit.
W. MEREDITH. Dark crimson, with gold reverse. An enlarged Edwin Molyneux. A reliable variety.
MARY DONELLAN. A splendid deep yellow.
JOSEPH STONEY. Best exhibition crimson.
HAROLD WELLS. Pure white. A monster.
MRS. J. C. NEIL. Soft canary yellow. An improved Cheltoni.

50c each, \$5.00 per doz., \$35.00 per 100

Also a Large Stock of the Leading Chrysanthemums on Hand. Varieties and Prices on Application.

The New Double Flowering Blue Lobelia **KATHLEEN MALLARD** Ready for Immediate Shipment. 25c each, \$2 50 per doz.

Scott Bros., ELMSFORD NURSERIES, Elmsford, N. Y.

TELEPHONE 474 TARRYTOWN

Established 40 Years

Rose Hill Nurseries

New and Rare Plants

NEW ROCHELLE, N. Y.

New York Office, Siebrecht Building, 425 Fifth Avenue

100,000 DAHLIAS

Premium Stock, guaranteed true to name.
 500,000 large Flowering Gladioli, hundreds of colors and variations mixed. Wholesale prices on application. Order now for spring delivery. Catalogue free.
J. L. MOORE, Northboro, Mass.

Attention Gardeners

WE ARE NOW DELIVERING

Novelty Chrysanthemums

THOSE FIRST PROPAGATED, STRONG PLANTS THAT BRING RESULTS NOW READY: All our Novelties (except Golden Glow); all the English '08 (except W. M. Moir); all the French '08.

Best Plants Ever in Stock

We are offering all the Standard Varieties both Commercial and Exhibition.

ELMER D. SMITH & CO.,

Successors to Nathan Smith & Son

ADRIAN, - - - MICH.

COLEUS

Verschaffeltii, Golden Queen, Fire Brand, Lord Palmerston, Queen Victoria, Beckwith's Gem. Prices of Rooted Cuttings by express, 60c, per 100; \$5 per 1000. Less than 250 of a variety will be charged at the 100 rate.

Golden Bedder, Hero, Tessey, Pearl of Orange. 75c, per 100; \$6 per 1000. Less than 250 of a variety will be charged at the 100 rate.

Fancy Varieties. A very fine assortment of twelve kinds not listed above, 75c, per 100; \$6 per 1000. 250, in assortment, our selection, at the 1000 rate.

MISCELLANEOUS PLANTS

AGERATUM, Stella Gurney, Princess Pauline, SALVIA Splendens, Bonfire, HELIOTROPE. Rooted cuttings, 75c, per 100; \$6 per 1000. **ALTER-NANTHERA, Red and Yellow.** Rooted cuttings, 50c, per 100; \$5 per 1000.

CARNATIONS

Rooted Cuttings

	100	1000
Winsor.....	\$6.00	\$50.00
White Perfection.....	2.50	20.00
Rose Pink Enchantress.....	3.50	30.00
Enchantress.....	2.50	20.00
Queen Louise.....	2.50	20.00

From 2½ inch pots, add \$1.00 per 100.

ASPARAGUS PLUMOSUS NANUS SEEDLINGS
 From flats, \$1.00 per 1000.

CHRYSANTHEMUMS

Standard varieties, ready for shipment. Rooted cuttings, \$2 per 100; \$15 per 1000. Send for list.

A. N. PIERSON, CROMWELL, CONN.

You will find something worth reading on every page of HORTICULTURE.

GLADIOLUS BULBS

100,000, from 1¼ inches up @ \$1.00 per 1000
 100,000, ¾ to 1¼ inches @ \$2.00 per 1000
 Cash with order. Description given on request.
 Nice block of California Privet, \$11.00 per 1000 and up, as to quality. Write for particulars.
 Nice lot of American Chestnut Trees at a bargain. Thirty-five large Sugar trees, most of them sample trees.
I. & J. L. LEONARD, IONA, N. J.

DREER SPECIALS



Golden Yellow Calla Elliottiana We have a fine lot of bulbs of this beautiful variety which if started into growth now can still be flowered for Easter. This Golden Calla is still but little known and always attracts attention. \$2.00 per doz., \$15.00 per 100.

Fancy Leaved Caladiums We are this season offering the finest set of Standard Fancy Leaved Caladiums that has yet been sent out at popular prices, 25 distinct sorts. \$1.50 per doz., \$10.00 per 100; the set of 25 varieties for \$3.00.

New Fancy Leaved Caladiums A set of twelve wonderful fully marked beautiful varieties. The set of 12 sorts for \$2.50, or \$20 per 100.

Canna King Humbert The best of the dark leaved, very large flowered brilliant scarlets and a perfect gem that pleases everyone. We are long on this and offer at the special price of \$1.25 per doz., \$8 per 100.

Canna Grand Chancellor Bulow A remarkably rich crimson scarlet that never sunburns, with flowers of good size and very free, was much admired in our trial grounds during the past two seasons. \$1.50 per doz., \$10 per 100.

Canna Frau Marie Nagel An introduction of Wilhelm Pfizers, the Canna specialist of Germany who has given us many important varieties. It is the most floriferous of the large creamy white sorts and contrasts fine with high-colored sorts. \$1.25 per doz., \$8 per 100.

New Decorative Dahlia Souvenir de Gustave Doazon The most sensational Dahlia of the season, of mammoth size, producing under ordinary cultivation flowers 6 inches in diameter and can be grown to measure full nine inches, it is of free growth and remarkably free flowering. Certain to become one of the most popular sorts for cutting and decorating, its pure scarlet color, immense size and unique form guarantee its future.

Rex Begonias We have at the present time the finest lot of Rex Begonias that we have been able to offer for many years, twenty distinct varieties, fine plants in 3 inch pots, \$1.25 per doz., \$8 per 100; the set of twenty varieties, one of each, for \$2.

HENRY A. DREER, 714 Chestnut St., PHILADELPHIA, PA.

ORCHIDS

We are at present booking orders for freshly imported Orchids for delivery 1908, of all leading kinds at reduced prices. We have just received the following:—*Oncidium Sarcodes*, *O. Forbesii*, *O. Tigrinum* and *Sophranites*, *Grandiflora* and *Coccinea*.

LAGER & HURRELL, Summit, N. J.

ORCHIDS

Largest Importers, Exporters, Growers and Hybridists in the World

Sander, St. Albans, England and 235 Broadway, Room 1 NEW YORK CITY

ORCHIDS

We shall receive in about two weeks' time fine importation of *Dendrobium Wardianum*, *D. Phalaenopsis*, *D. Formosum giganteum*.

April: Most all the *Cattleyas*, *Vandas*, *Oncidium*, e. c. Write for Price List.

CARRILLO & BALDWIN, Secaucus, N. J.

ORCHIDS for Spring Delivery

NEW IMPORTATIONS

Cattleyas, *Laelias*, *Oncidium*, etc.

WRITE FOR PRICES

Now is the time to Pot Orchids. Best Quality of Peat, Moss and Baskets on hand.

JOSEPH A. MANDA, 191 Valley Road, WEST ORANGE N. J.

Write at once for our quotations on all

ORCHID IMPORTATIONS

FOR 1908 DELIVERY

JULIUS ROEHRS CO.,

The Orchid Nurseries, Rutherford, N. J.

NEPHROLEPIS SCOTTII

in the following sizes, extra good value

25c., 50c., 75c., and \$1

Grand Specimen Plants at \$3, \$4, \$5, \$6.

JOHN SCOTT

Rutland Road and E. 45th St.

Tel. 2890 Bedford **BROOKLYN, N. Y.**

NEP. WHITMANI

2 1/4 in., \$5.00 per 100

NEP. WHITMANI

3 1/2 in., \$25.00 per 100

BOSTON FERNS

2 1/4 in., \$3.00 per 100

H. H. BARROWS & SON Whitman, Mass.

FERNS

Boston, 4 inch 12c, 5 inch 25c.

Pteris, 3 inch 5c.

Elegantissima, 2 1/4 inch 6c, 3 inch 10c,

4 inch, 15c.

BAUR FLORAL CO., Erie, Pa.

LILIUM AURATUM

9-11 \$75 per 1000

ROSEUM and RUBRUM

9-11 \$65 per 1000

MULTIFLORUM

7-9 \$45 per 1000

D. RUSCONI 128 West 6th St. CINCINNATI, OHIO

Order Now for St. Patrick's Day.

25,000

SHAMROCKS

We have 25,000 Irish Shamrocks in those popular one-inch pots; also in 1 1/4 in. pots only. **SHAMROCKS** in these tiny pots are great sellers. Price for either size, \$5.00 per 100, \$40.00 per 1000. Cash with order. Get in line now and don't get left this year. Samples on application.

LEONARD COUSINS, JR.

Concord Junction, Mass.

SHAMROCKS

IRISH: THE REAL THING, GREEN

Very Fine and Strong Plants ready now for delivery: Perfect Beauties, per 100, \$4.00; per 1000, \$30.00; 50 cts. per dozen, postpaid. Extras added.

THE HOME OF PRIMROSES

JOHN F. RUPP, Shiremanstown, Pa.

JAPANESE
THE YOKOHAMA NURSERY CO.
31 BARCLAY STR. NEW YORK.
LILIES
PLANTS
BAMBOO STAKES

A WELL-MADE WREATH.



The wreath form is deservedly the most generally preferred among the great variety of so-called "designs" which florists are called upon to provide for funeral use. Unlike many of the other emblematic devices which find more or less favor the wreath affords latitude for the display of unlimited taste and skill in color effect and floral combinations and is, in the hands of the artist, very much more than a wire frame with various short stemmed flowers stuck into it. Its sentiment is touching and appropriate and whatever prejudice may exist

among cultivated people against the type of "funeral design" as often seen can, at least, be waived when the design in question is a well-made wreath. The example shown in the accompanying illustration, the design adopted by the Kentucky Society of Florists and made by Jacob Schulz, is in excellent taste and is suggestive of a great variety of graceful combinations whereby the choicest flowers may be made to serve the purposes of a funeral tribute without mutilation or doing violence to their natural gracefulness.

NEWS NOTES.

J. A. Kepner, florist, Harrisburg, Pa., will remove to 1110 East Market St.

C. P. Brunner is in charge of the cut flower department at Roth & Livingston's drug store, Springfield, O.

Elder & Carhart is the name of a new firm of flower growers at Mineral Ridge, O., located at Cherryhurst farm.

George E. Valker has left Minneapolis for Minot, N. D., where he and Ernest Eakman will open a flower store.

About thirty of the Indianapolis florists made the trip to Richmond last Wednesday and were well repaid for their time.

George M. Dideman and Joshua Horner, Jr., have been appointed receivers for The Fernery, Baltimore, Md.; liabilities, \$3,200.

The employees of J. A. Budlong Co., Providence, R. I., presented a purse of \$100 to the family of Henry Hobday, whose life was so suddenly taken recently.

W. H. Sabin is in charge of the northwestern branch of the Phoenix Nursery Co., at Fargo, N. D., and S. D. Weymouth of the eastern branch at Waterville, Me.

George C. Hartung's greenhouse near Chicago will be known as the Kensington Greenhouses. Large consignments of geraniums are being shipped, and the prospects for spring trade are reported good.

Messrs. Knight & Struck have been given the option for the next six months on the sale in America of *Cypridium* Gay Gordon (*C. Thompsonii* X *Lady Wimborne*), never before offered in this country. This is a wonderfully beautiful flower. The stock is thus far limited to fifteen plants.



BOSTON'S BEST

In Quality and Design

Can be relied upon when you transfer your retail orders to

EDWARD MACMULKIN

194 Boylston Street, Boston

Send flower orders for delivery in

BOSTON

and all

NEW ENGLAND POINTS

THOS. F. CALVIN

124 Tremont St., Boston

TRANSFER

Your orders for flower or plant delivery in Eastern New England to

JULIUS A. ZINN,

2 Beacon St., Boston.

Fine Design Work a Specialty

YALE

Orders for flower deliveries to Yale College and all other Connecticut points carefully filled and delivered by

J. N. CHAMPION & COMPANY

1026 CHAPEL STREET NEW HAVEN, CONN.

M. A. BOWE

In the Heart of New York City

Telegraph or write

M. A. BOWE, PHONE 2070 38th ST., 1294 BROADWAY, N. Y.

Our Motto -- The Golden Rule.

PHILADELPHIA NOTES.

On the sick list this week are Arthur Niessen of the Leo Niessen Co., and J. D. Eisele of Dreer's. These active and hustling spirits no doubt make ideally patient (?) patients.

Visitors this week were: N. E. Keeney of N. B. Keeney & Sons, LeRoy, N. Y.; W. A. Manda, South Orange, N. J., and Mr. Smith of Smith & Fetters, Cleveland, O.

Joseph Callahan, lately with Penneck Bros., now runs the old Charles I. Kent place at 3804 Market street. Among his assistants are Mr. Eastwell, late of the Bellevue-Stratford Flower Shop.

Jno. E. Andre of Doylestown, who has made a record for himself on Brides and Bridesmaids in the Philadelphia market the past ten years, thinks My Maryland one of the best propositions among the newer rose claimants. Jno. H. Dodds and Samuel Batchelor are also favorably impressed with My Maryland. These gentlemen are famous prize-takers at the Philadelphia shows, and both of them will grow the new rose the coming season.

**JOHN BREITMEYER'S
SONS**
Cor. Miami and Gratiot Aves.
DETROIT, MICH.
**Artistic Designs . . .
High Grade Cut Blooms**
We cover all Michigan points and good
sections of Ohio, Indiana and Canada

Of Interest to Retail Florists

WASHINGTON The past week, the last before the beginning of Lent, proved to be one of the busiest of the season. There were numberless gaieties and several funerals of more than ordinary concern, the one of the Rt. Rev. Henry Y. Satterlee, Bishop of Washington, being a national bereavement, as was testified by the great number of handsome floral offerings. The interment was in the little sanctuary at Mt. St. Alban, the site of the proposed Cathedral of SS. Peter and Paul, and the decorating of the chancel was a perfect triumph of floral art. There was nothing to mar the purple and white effect, only lilies and violets being used and the graceful southern smilax. Floral pieces numbering up in the hundred figures were sent by every faith and well-nigh every church in Washington, to say nothing of those from private individuals and persons high in public rank.

CHICAGO The retail stores have had a fine chance to stock up and make a very beautiful display in their windows for the past week with spring flowers predominating and a background of azaleas and potted tulips all at very low prices. As one retailer remarked, they have waited a long time for the season to come when they can sell carnations at 50 cents per dozen at a profit and violets at 25 cents per bunch, in some of the downtown stores; also carnations at 25 cents per dozen.

A fad for the "Japanese air plant" is on. Many of the retailers are utilizing this very attractive little sea moss to dispose of the small jardinières and bric-a-brac that collect in a retail store. The demand has caused a scarcity of the plant and an advance of twenty per cent. in price.

NEW RETAIL FLOWER STORES.

- T. L. Metcalf, Owensboro, Ky.
- Nanz Floral Co., Central City, Ky.
- Schoen Floral Co., 409 Adams street, Toledo, O.
- Wellston Florist & Nursery, 6103 Easton avenue, St. Louis, Mo.
- Kensington Flower Shop, 689 Boylston street, Boston., H. M. Collins, proprietor.

Spruce, hemlock and balsam boughs for lining graves, protecting plants, and for backgrounds for large decorations should be in the regular stock of every retail florist. Harry J. Smith of Hinsdale, Mass., makes a specialty of supplying them by 100 lbs., ton or car-load lots, or will send sample bale on request free outside of transportation charges.

The floral department at Cafe Martin, Broadway and 26th street, New York, is now in charge of David D. Howells.

ATLANTA FLORAL CO.
41 Peachtree Street, ATLANTA GEORGIA.

Florists Out of Town

Taking orders for delivery in **New York or Vicinity** can have them filled in best manner and specially delivered by **Thomas Young, Jr.**
500 F. 5th Ave., New York City
Telephone 847 Bryant.

ALEX. McCONNELL
571 FIFTH AVENUE
NEW YORK CITY
Telegraphic orders forwarded to any part of the United States, Canada, and all principal cities of Europe. Orders transferred or intrusted by the trade to our selection for delivery on steamships or elsewhere receive special attention.
Telephone Calls, 487 and 488 38th St.
Cable Address, ALEXCONNELL

**William J. Smyth
FLORIST**
Cor. Michigan Ave. and 31st St., CHICAGO
We ship to all points in Illinois and Iowa.
Phones: Douglas 744, Douglas 523, Douglas 740

WILLIAM H. DONOHUE
FLORAL DECORATOR
17 East 28th St., New York
Special Attention to Theatre and Steamer Orders, and reliable deliveries guaranteed.

DAVID CLARKE'S SONS
Deliver orders from any part of the country to **New York City**
Or **OUT-GOING STEAMERS**
Write or telegraph
2139-2141 Broadway, New York
Telephone 1552-1553 Columbus

**PROMPT DELIVERY IN
BOSTON**
AND ALL NEW ENGLAND POINTS
HOUGHTON & CLARK
396 Boylston St., Boston, Mass.

Flower Deliveries
In Brooklyn and other Long Island Points New York City, New Jersey, etc. At Theatres, Hotels, Steamers or Residence.
WILSON
Fulton St. and Greene Ave., Brooklyn, N.Y.

YOUNG & NUGENT
42 West 28 St., NEW YORK
"FLOWERS BY TELEGRAPH"
JACOB SCHULZ, 644 Fourth Ave., LOUISVILLE, KY.
Cut Flowers of BEST QUALITY in season delivered promptly to any address.
Write, Telegraph or Telephone.
Cumberland and Home Phones 223 and 984

P. J. and J. E. HAUSWIRTH
232 Michigan Ave.
CHICAGO
AUDITORIUM ANNEX Tel. Harrison 585

**SAMUEL MURRAY
Florist**
Coates House Conservatory
1017 BROADWAY, KANSAS CITY, MO
Both 'Phones 2670 Mafn

**FRED C. WEBER
FLORIST**
4326-28 OLIVE STREET ST. LOUIS, MO.
Established 1873
Long Distance Phone Bell Lindell 676

WASHINGTON, D. C.
GUDE'S
GUDE BROS CO
FLORISTS
1214 F ST NW
WASHINGTON DC

**Geo. H. Cooke
FLORIST**
Connecticut Avenue and L Street
WASHINGTON, D. C.

The Park Floral Co.
J. A. VALENTINE
Pres.
DENVER, COLORADO

**WILLIAM L. ROCK
FLOWER CO.**
KANSAS CITY, MO.
will carefully execute orders for Kansas City and any town in Missouri or Kansas.

ALBANY, N. Y.
EYRES
Flowers or Design Work
DELIVERED IN ALBANY AND VICINITY ON TELEGRAPHIC ORDER.
11 NORTH PEARL ST., ALBANY, N. Y.

EASTER PLANTS

**Azaleas, Baby Ramblers,
Hydrangeas, Lilies,
Geraniums**

In fine condition. Write for Prices

WM. W. EDGAR CO., Waverley, Mass.

**CHOICE SPRAYS OF
PLUMOSUS and SPRENGERI**
50c. per bunch

CHOICE VALLEY WHITE VIOLETS
\$3.00 per 100 \$1.50 per 100

S. S. PENNOCK - MEEHAN CO.
1608-1620 Ludlow St. PHILADELPHIA
"The" Wholesale Florists of Philadelphia

EVERYTHING SEASONABLE IN
CUT FLOWERS
EDWARD REID, Wholesale Florist
1526 Ranstead St., PHILADELPHIA
STORE CLOSES 3 P. M.

CHAS. W. McKELLAR
51 WABASH AVE., CHICAGO
Western Headquarters for Choice Orchids
Valley, Roses and all Cut Flowers

PETER REINBERG
WHOLESALE
CUT FLOWERS
51 Wabash Av., Chicago, Ill.
In writing advertisers, mention Horticulture

CUT FLOWER BOXES
EDWARDS FOLDING BOX CO
MANUFACTURERS
PHILADELPHIA, PA.

AMERICAN BEAUTY and all other
ROSES
LILY OF THE VALLEY, CARNATIONS
WELCH BROS., 226 Devonshire St., Boston, Mass.

AMERICAN BEAUTIES
Fancy BRIDES and MAIDS
W. E. McKISSICK WHOLESALE FLORIST
PHILADELPHIA
1619-1621 RANSTEAD ST.

DAILY CONSIGNMENTS
From 40 to 60 Growers
We can care for your cutflower wants to advantage.
E. F. WINTERSON CO.
46-47-49 WABASH AVE., CHICAGO

J. J. HARTY & COMPANY
WHOLESALE AND COMMISSION **FLORISTS**
3112 G Street, N. W., Washington, D. C.

WHOLESALE FLOWER MARKETS—TRADE PRICES—Per 100 TO DEALERS ONLY

	CHICAGO March 2	TWIN CITIES March 2	PHILA. March 2	BOSTON March 4
ROSES				
Am. Beauty, Fancy and Special...	40.00 to 60.00	45.00 to 60.00	60.00 to 75.00	50.00 to 60.00
" Extra.....	25.00 to 30.00	30.00 to 40.00	40.00 to 60.00	30.00 to 40.00
" No. 1.....	10.00 to 25.00	20.00 to 30.00	20.00 to 30.00	15.00 to 25.00
" Lower grades.....	4.00 to 8.00	10.00 to 20.00	6.00 to 15.00	4.00 to 10.00
Bride, "Maid, Fancy & Special.....	0.00 to 8.00	8.00 to 11.00	10.00 to 12.00	8.00 to 10.00
" Extra and No. 1.....	4.00 to 6.00	6.00 to 8.00	8.00 to 10.00	4.00 to 6.00
" Lower grades.....	2.00 to 4.00	5.00 to 6.00	3.00 to 6.00	2.00 to 3.00
Killarney, Richmond, Fan. & Sp.....	6.00 to 8.00	8.00 to 11.00	10.00 to 30.00	8.00 to 12.00
" Lower grades.....	2.00 to 4.00	5.00 to 7.00	3.00 to 10.00	2.00 to 6.00
Chat-nay, Wellesley, Fan. & Sp.....	4.00 to 6.00	8.00 to 11.00	12.00 to 15.00	8.00 to 10.00
" Lower grades.....	2.00 to 4.00	5.00 to 7.00	4.00 to 10.00	2.00 to 6.00
Golden Gate, Ivory.....	4.00 to 6.00	5.00 to 10.00	3.00 to 10.00	2.00 to 8.00
CARNATIONS				
Fancy and Novelties.....	1.50 to 3.00	2.00 to 3.00	4.00 to 5.00	2.00 to 3.00
Ordinary.....	.75 to 1.50	1.50 to 2.00	1.00 to 2.00	1.00 to 2.00
MISCELLANEOUS				
Violets.....	.25 to .75	.50 to 1.00	.25 to 1.00	.35 to .60
Cattleyas.....	50.00 to	40.00 to 50.00	60.00 to 75.00	50.00 to 60.00
Cypripediums.....	1.00 to 15.00	12.00 to 15.00	12.50 to 15.00	8.00 to 10.00
Lilies.....	8.00 to 12.00	10.00 to 12.00	10.00 to 12.50	8.00 to 12.00
Lily of the Valley.....	2.00 to 3.00	2.00 to 3.50	1.50 to 4.00	2.00 to 3.00
Freesia.....	1.50 to 2.00	2.00 to 3.00	1.00 to 3.00	1.00 to 2.00
Rom'o Hy, Paper White Nar.....	2.00 to 3.00	2.00 to 3.00	1.00 to 3.00	1.00 to 2.00
Daffodils.....	2.00 to 3.00 to 2.50	1.50 to 3.00	1.00 to 2.00
Tulips.....	2.00 to 4.00 to 2.50	1.50 to 4.00	1.00 to 3.00
Mignonette..... to 6.00	4.00 to 8.00	1.50 to 4.00	3.00 to 4.00
Gardenias.....	25.00 to 35.00	35.00 to 50.00	30.00 to 40.00	25.00 to 40.00
Lilac per bunch.....	1.00 to to 1.50	.25 to 2.00	1.00 to 1.50
Sweet Peas.....	.50 to .75 to 1.00	.50 to 1.00	.50 to 1.00
Adiantum.....	.55 to 1.00	.75 to 1.00	1.00 to 1.50	1.00 to 1.50
Whitmanii Fronds..... to to	1.50 to 4.00	2.00 to 3.00
Smilax.....	10.00 to 12.00	12.00 to 15.00	15.00 to 20.00	10.00 to 12.00
Asparagus Plumosus, striggs.....	35.00 to 50.00	35.00 to 50.00	50.00 to 75.00	25.00 to 50.00
" " & Spreng (100 bchs)	25.00 to 35.00	35.00 to 40.00	3.00 to 50.00	15.00 to 50.00

THE FLORISTS' SUPPLY HOUSE OF AMERICA

Without a rival in knowledge of the requirements of the trade and the ability to supply them. Our New Illustrated Catalogue, recognized as a work of art unprecedented in its line for variety, novelty and completeness, tells the story fully, and if you have not yet sent for it, do so now.

'TIS FREE TO EVERYBODY IN THE TRADE

H. BAYERSDORFER & CO., 1129 Arch St., Philadelphia, Pa.

FLOWER MARKET REPORTS

BOSTON This market is overloaded with flowers of all descriptions. The week has been phenomenally dull and the product has been coming in regardless of the fact that it is not needed. American Beauty roses are not plentiful, but if they were there would be no place for them. As to everything else the dealers are at their wits' end to find storage room and a possible buyer. Prospects indicate a dull Lent.

BUFFALO For the past two weeks the market has been in bad condition and it looks as if the Lenten dullness had already come upon us. Stock came in abundantly and almost everything along the line suffered. The zero weather did not help matters any. No better quality of carnations, roses, and other flowers have been had during the season, but only small prices if any could be obtained. The lily family was well represented but they failed to move from their position; also lily of the valley and all bulbous stock, though there has been less of the latter than in previous years. Good Beauties have not been plentiful, though Brunner, Richmond, Killarney, Ivory and other teas have been abundant with prices on the downward scale. Sweet peas, violets, gardenias, etc., were in good supply with light demand.

CHICAGO Thunder and lightning and wind in and around Chicago, ushered in the month of March like the traditional lion, thereby affording the consolation that early spring is assured and of course fine weather for Rose Show week at the latter end of this month. The market for the past week was very dull, with plenty of carnations, roses and other stock. It was a treat for the retail stores to be able to stock up for little money. For good shipping stock the prices remain about the same. American Beauties are very scarce. New York violets and singles are being jobbed off at any price. Lilies and callas are plentiful with little demand; other bulbous stock about the same. Lily of the valley of good quality commands good prices. The shippers are at a loss to know why there were so few orders from New Orleans. In the past years the Mardi Gras festival has been the best shipping day out side of holiday business, as much as two full express cars leaving here, but this year there was but a slight increase over regular shipments. Perhaps there was plenty of stock at home. The Lenten season does not as a rule make much difference in the western cities, so steady prices are looked for from now on.

INDIANAPOLIS Trade conditions for the past week were a little better with a few small decorations and floral work. Sweet peas, lily of the valley, freesias, daisies and lilacs are coming in in good supply with fair demand. Bulbous stuff is more than enough with daffodils selling the best, tulips being a drag on the market. Business for February will fall off 15 to 20 per cent. compared with last year.

NEW YORK The coming in of Lent has accentuated what was already a badly demoralized flower market and at present everything is flat. As to prices, they have been below reason for some time. The growers and dealers have got used to this fact and so the shock of the Lenten season has made no impression, for everybody is "case-hardened." As to the coming weeks, all are reconciled to the worst, and whatever is to happen is to happen.

PHILADELPHIA Some say conditions are improved here this week; others that they remain about the same. American Beauty roses are scarcer, but there is no appreciable advance over quoted rates. Richmond is good and sells fairly well. Killarney is still off color a little. Brides are still in slack demand. Carnations were never so plentiful. Conditions on the latter here are worse if anything than represented in last report. Violets go a little better. No improvement on bulb stock. Lilac and Acacia pubescens sprays find a ready market. Greens also are in healthy condition. Orchids scarce.

WASHINGTON There is a dearth of all kinds of good green in this market. It is hard to obtain either kind of asparagus at any price and smilax is not to be thought of. Carnations and sweet peas are too plentiful to be interesting though up to the present writing they have kept up in price. The market is flooded with all kinds of bulbous stock, which sells readily. Could the weather behave itself three consecutive days, the spirits of persons would go up even if the price of flowers did not.

TWIN CITIES The market has been quite steady of late with the exception of violets and bulbous stock of which there is some surplus. Roses are still short except American Beauty. Wellesley, Golden Gate and Killarney are not grown very extensively here; instead some of the growers have Kate Moulton, which brings about the same as Richmond. While roses had an upward tendency last week, violets came down some, retailers selling them for 25 cents a bunch of 25.

BUSINESS CHANGES.

Graser & Humphreys succeed the Mt. Sterling Floral Co., Mt. Sterling, Ky.

The greenhouses formerly occupied by Miss Maria Minge, Mobile, Ala., have been sold to T. Loding.

MacIntosh, the florist, will be located at the corner of 47th St. and Broadway, New York, after May 1.

Wurster & Higgins, Manchester, Mich., have dissolved partnership and will work on independent lines hereafter.

C. E. Howe of Dover, N. H., has bought the business of D. E. Dow of Laconia, and will carry it on with Roy Thomas of Dover as manager.

Chas. H. Fisk, who recently took charge of the Halle store at 548 W. Madison St., Chicago, has now transferred all his interests to his Ogden avenue place.

INCORPORATED.

Alpha Floral Co., Denver, Colo.; E. S. Kennedy, L. O. Brown, W. S. McClain; capital, \$3000.

Holm & Olson Co., St. Paul, Minn.; G. P. Holm, O. J. Olson, S. D. Dysinger; capital, \$75,000.

Central Nursery & Floral Co., Kalamazoo, Mich.; L. P. Thurston, J. L. Sornberger, W. P. Upjohn, V. L. Palmer; capital, \$50,000.

Bargains in good stock.

WHAT?

THEY'RE STICKING OUT
all over these pages.

E. A. BEAVEN

Southern Wild Smilax,
Log Mosses,

Natural and Perpetuated — at Wholesale,

EVERGREEN, ALABAMA.

H. J. Smith

HARDY CUT FERN
DEALER, ETC.,

Write for Prices

HINSDALE,

MASS.

Alex Mann, Jr. Co. Inc.

Wholesale Dealer in

Florists' Supplies and Cut Flowers

White Doves, \$9.00 per doz.
Galax Leaves.

1125 Polk Street, San Francisco, Cal.

J. B. Murdoch & Co.

Wholesale Florists

FLORISTS' SUPPLIES

714 Penn Ave., PITTSBURG, PA.

Long Distance Phone 1435 Court.

J. KOPELMAN & CO.

Wholesale Dealers in

Cut Flowers and Florists' Supplies

EVERGREEN AND FERN LEAVES

OF ALL KINDS.

21 Washington St., PROVIDENCE, R. I.

Telephone Connection.

ROBERT J. DYSART,

Public Accountant and Auditor

Simple methods of correct accounting
especially adapted for florists' use.

Books Balanced and Adjusted

Merchants Bank Building

28 STATE ST.,

BOSTON

Telephone, Main 58

The KERVAN CO.

113 W. 28th ST.
New York

WHOLESALE DEALERS

Fresh cut Palmetto & Cycas Palm Leaves, Galax, Leucothoe, Ferns and Mosses. All Decorating Evergreen.

JOHN YOUNG
WHOLESALE FLORIST
 Finest American Beauties and
 Carnations
 51 West 28 St. - NEW YORK

FORD BROTHERS
 48 West 28th Street, NEW YORK
FINE ROSES FANCY CARNATIONS
 A Full Line of All CUT FLOWERS
 Telephone, 3870 or 3871 Madison Square

H. E. FROMENT,
 Wholesale Commission Florist,
 Choice Cut Flowers,
 57 West 28th St., :: NEW YORK.
 Telephones: 2200, 2201, Madison Square.

The Reliable Commission House
 Richmond Roses and Rich Flowers
 of all varieties
JOS. S. FENRICH
 110 W. 28th Street, New York
 Tel. 324-325 Madison Square

Established 1891 BUY FROM SHIP TO TRY **ME**
ALFRED H. LANGJAHR
 All Choice Cut Flowers in Season
 55 West 28th St., New York
 Telephone 3924 Madison Square.

JOHN I. RAYNOR
Wholesale Commission Florist SELLING AGENT FOR LARGEST GROWERS
 A full line of Choice Cut Flower stock for all purposes. Comprises every variety grown for New York market, at current prices
 TEL. 1998 MADISON SQUARE 49 W. 28 St., New York City

Walter F. Sheridan
 Wholesale Commission Dealer in
CHOICE CUT FLOWERS
 39 West 28th Street, New York
 Telephone: 3532-3533 Madison Square

HEADQUARTERS FOR NOVELTIES
ORCHIDS A SPECIALTY
 THE HIGHEST GRADE OF **VALLEY** ALWAYS ON HAND
 GARDENIAS, DAISIES, ROSES AND CARNATIONS
 Telephone
JAMES McMANUS, 759 Mac. Sq. 42 W. 28th St., New York

PHILIP F. KESSLER 55 & 57 W. 26th St., New York City
 Commission Dealer, Wholesale Buyer and Seller of
CUT FLOWERS
 Open from 5 a. m. to 6 p. m. Sunday till 10 a. m.
 Tel., 5243 and 2921 Madison Sq. Res., 345 J., Newtown.
Finest Lilies in the Market Every Day in the Year.

WHOLESALE COMMISSION FLORIST 106 W. 28 ST. NEW YORK
J. K. ALLEN Telephone 167 Madison Sq.
 OPEN 6 A.M. DAILY
 We have a good regular outlet for seasonable flowers

NEW YORK QUOTATIONS PER 100—TO DEALERS ONLY

	Last Half of Week ending Feb. 29 1908	First Half of Week beginning Mar. 2 1908		Last Half of Week ending Feb. 29 1908	First Half of Week beginning Mar. 2 1908
Roses			Cattleyas	25.00 to 50.00	40.00 to 60.00
Am. Beauty, fan and sp.	40.00 to 50.00	40.00 to 50.00	Cypripediums	6.00 to 8.00	8.00 to 10.00
" extra	10.00 to 15.00	20.00 to 30.00	Lilies	6.00 to 10.00	10.00 to 12.00
" No. 1	8.00 to 12.00	8.00 to 15.00	Lily of the Valley	1.00 to 2.00	1.00 to 2.00
" Lower grades	1.00 to 2.00	2.00 to 4.00	Freesia	1.00 to 2.00	1.00 to 1.50
Bride, 'Maid, fan and sp.	6.00 to 10.00	6.00 to 8.00	Roman Hy., Paper White Nar. .	1.00 to 2.00	1.00 to 1.00
" extra	1.00 to 5.00	4.00 to 5.00	Daffodils	1.00 to 1.50	1.00 to 1.00
" lwr. grds.	1.00 to 2.00	2.00 to 3.00	Tulips	1.00 to 2.00	1.00 to 2.00
Killarney, Richmond, tacy & spec	6.00 to 10.00	6.00 to 10.00	Alphonette	2.00 to 4.00	2.00 to 4.00
" lower grades	1.00 to 2.00	2.00 to 4.00	Gardenias	10.00 to 25.00	10.00 to 35.00
Chatenay, Wellesley, fan, and spec.	6.00 to 10.00	6.00 to 10.00	Lilac p r bunch to 75 to .50
" lower grades	1.00 to 2.00	2.00 to 4.00	Sweet Peas	0 to .75	50 to .75
Golden Gate, Ivory	1.00 to 6.00	2.00 to 6.00	Adiantum75 to 1.50	.75 to 1.50
Carnations, Fancy and Novelties.	1.00 to 2.00	1.00 to 2.00	Smilax	8.00 to 10.00	8.00 to 12.00
" Ordinary to .50	.50 to .75	Asparagus Plumosus, strigs...	25.00 to 40.00	25.00 to 40.00
Violets20 to .25	.20 to .35	" " & Sprea. (too bchs.)	10.00 to 15.00	20.00 to 35.00

B. S. SLINN, Jr.
 —WHOLESALE FLORIST—
 55 & 57 W. 26th St., New York City
 Tel., 3864 Madison Sq. Shipping Orders Solicited.
VIOLETS Roses and Carnations

TRAENDLY & SCHENCK
WHOLESALE FLORISTS
 Furnish best stock at fair prices all the year round Send for quotations on fall orders
 Tel. 798-799 Madison Sq. 44 West 28th Street, New York City

Edward C. Horan
Wholesale Florist
 55 WEST 28th ST.
 Tel 1462 Madison Square New York
 1463

Alexander J. Guttman
THE WHOLESALE FLORIST OF NEW YORK
 43 WEST 28th STREET
 PHONES. 1664-1665 MADISON SQUARE
ENOUGH SAID



HARDY CUT FERNs

Sphagnum Moss, Extra Large Bales, per bale, \$1.25. Fancy and Dagger Ferns our specialty. A trial order will convince you that we ship only first-class stock. Headquarters for Florists' supplies and wire work. All cut flowers in season. **BOXWOOD**, per bunch 35c, 50 lbs. \$7.50.

MICHIGAN CUT FLOWER EXCHANGE, INC., All 'phone connections 38-40 Broadway, Detroit, Mich.

FANCY and DAGGER
Extrafine, \$1.75 per 1000. Bronze and Green Galax, \$1.25 per 1000. Leucothoe Sprays, \$1.00 per 100, \$7.50 per 1000.

Headquarters in Western New York
FOR
ROSES, CARNATIONS
And all kinds of Seasonable Flowers
Wm. F. Kasting Co.
Wholesale Commission Florist, also Dealer in Florists' Supplies and Wire Designs.
383-87 ELLICOTT ST. BUFFALO, N. Y.
Give us a trial. We can please you.

FRANK S. HICKS & CO.
Wholesale Florists.
Open Now for Consignments of Cut Flowers.
52 West 28th Street, - New York City
Tel. 2920 Mad. Sq.

FRANK MILLANG
Wholesale Florist
Telegraphic Orders Filled and Delivered.
55-57 West 26th St., New York City.

HENRY M. ROBINSON & CO.
Wholesale and Commission
FLORISTS
Hardy Cut Evergreens and Florists' Supplies
15 Province St. and 9 Chapman Place,
BOSTON, MASS.

Best Flowers
IN THE
BOSTON MARKET
N. F. McCarthy & Co.
84 Hawley St., BOSTON, MASS.
Send for Prices

WHOLESALE FLOWER MARKETS. — PER 100. TO DEALERS ONLY.

	CINCINNATI March 3	DETROIT March 2	BUFFALO March 2	PITTSBURG March 2
ROSES				
Am. Beauty, Fan, and Sp..... to	25.00 to 35.00	30.00 to 50.00	50.00 to 60.00
“ Extra	25.00 to 30.00	20.00 to 25.00	13.00 to 30.00	35.00 to 40.00
“ No. 1	10.00 to 15.00	5.00 to 20.00	10.00 to 15.00	15.00 to 20.00
“ Lower grades.....	5.00 to 6.00	6.00 to 15.00	5.00 to 10.00	8.00 to 10.00
Bride, 'Maid, F. & S.....	8.00 to 10.00	8.00 to 12.00 to 10.00	10.00 to 12.00
“ Extra	6.00 to 8.00	4.00 to 6.00 to 6.00	6.00 to 8.00
“ Low gr.....	3.00 to 5.00 to	3.00 to 4.00 to 5.00
Killarney, Richmond, Fan, & Sp.....	6.00 to 8.00	8.00 to 12.00 to 10.00	10.00 to 12.00
“ Lower grades.....	4.00 to 6.00	4.00 to 6.00	3.00 to 6.00	6.00 to 8.00
Chateau, Wellesley, Fan & Sp.....	6.00 to 8.00	8.00 to 12.00 to 15.00	10.00 to 12.00
“ Lower grades.....	4.00 to 6.00	4.00 to 6.00	7.00 to 10.00	6.00 to 8.00
Golden Gate, Ivory.....	6.00 to 8.00	4.00 to 6.00	3.00 to 8.00	6.00 to 8.00
CARNATIONS				
Fancy and Novelties..... to 3.00	2.00 to 2.50	3.00 to 4.00 to 3.00
Ordinary.....	1.00 to 2.00	1.50 to 2.00	1.50 to 2.00	1.00 to 2.00
MISCELLANEOUS				
Violets	50 to .75	1.00 to 1.50	.40 to .75	.50 to .75
Cattleyas	40.00 to 50.00	35.00 to 50.00	40.00 to 60.00	50.00 to 75.00
Cypripediums	12.00 to 15.00	12.00 to 15.00	10.00 to 15.00 to
Lilies	12.00 to 15.00	12.50 to 15.00	4.00 to 15.00	8.00 to 12.50
Lily of the Valley.....	3.00 to 4.00	3.00 to 4.50	2.00 to 4.00	3.00 to 4.00
Freesia	2.00 to	3.00 to 4.00	1.00 to 3.00	1.00 to 2.00
Roman Hy., Paper White Nar.....	2.00 to 3.00	2.00 to 3.00	2.00 to 3.00	1.00 to 3.00
Daffodils.....	2.00 to 3.00	3.00 to 4.00	2.00 to 3.00	2.00 to 3.00
Tulips.....	2.00 to 4.00	3.00 to 6.00	2.00 to 3.00	1.00 to 3.00
Mignonette.....	6.00 to 8.00	4.00 to 8.00	2.00 to 5.00	2.00 to 4.00
Gardenias.....	35.00 to 50.00	35.00 to 50.00	25.00 to 40.00 to
Lil. c p r bunch..... to 1.50 to 1.00	.50 to 1.00 to
Sweet Peas50 to .75	1.50 to 2.00	.40 to 1.00	.50 to 1.00
Adiantum to 1.00	1.50 to 2.50	.50 to 1.00	1.00 to 1.25
Whitmanii Fonds to to	8.00 to 10.00 to
Smilax to 12.50 to 15.00 to 15.00	10.00 to 12.50
Asparagus Plumosus, strings.....	40.00 to 50.00	40.00 to 50.00	40.00 to 60.00 to 50.00
“ “ & Spren (100 bchs.)	25.00 to 35.00	25.00 to 35.00	25.00 to 40.00	40.00 to 75.00

SAMUEL A. WOODROW
WHOLESALE PLANTSMAN
Palms, Large and Small Ferns, etc.
53 West 30th Street, NEW YORK
Telephone 2083 Madison

WILLIAM H. KUEBLER
Brooklyn's Foremost and Best
WHOLESALE COMMISSION HOUSE
A First Class Market for all CUT FLOWERS
28 Willoughby St., Brooklyn, N. Y.
Tel. 4591 Main

CLEARY'S HORTICULTURAL CO.
Management AMBROSE T. CLEARY
Wholesale Contracting, Jobbing, Auction
HORTICULTURAL PRODUCTS
of every description.
Consignments Received. Surplus Stock Converted.
62 Vesey St., NEW YORK

Moore, Hentz & Nash,
Wholesale Commission Florists,
55 and 57 West 26th Street,
Telephone No. 756
Madison Square. **New York.**

H. C. BERNING
Wholesale Florist
1402 Pine Street, ST. LOUIS, MO.

MILLANG BROS.
WHOLESALE COMMISSION FLORISTS
41 West 28th Street
Telephones 3860 3861 Madison **NEW YORK**

A. MOLTZ
Will purchase flowers on order in N. Y. market and ship carefully at prevailing wholesale prices. Address
55-57 West 26th Street, New York City

REED & KELLER
122 West 25th St., New York
Florists' Supplies
We manufacture all our
Metal Designs, Baskets, Wire Work & Novelties
and are dealers in
Glassware Decorative Greens and Florists' Requisites.

In writing to Advertisers kindly mention Horticulture

Buyer's Directory and Ready Reference Guide

Advertisements under this head, one cent a word. Initials count as words.

Regular advertisers in this issue are also listed under this classification without charge. Reference to List of Advertisers will indicate the respective pages.

Buyers failing to find what they want in this list will confer a favor by writing us and we will try to put them in communication with reliable dealers.

ACCOUNTANT

R. J. Dysart, 23 State St., Boston.
For page see List of Advertisers.

ADIANTUMS

J. A. Peterson, McHenry Ave., Westwood,
Cincinnati, Ohio.
Adiantum Farleyense.

ALTERNANTHERAS

Red Alternantheras at 40 cents per 100.
C. W. Moeckel, 17 Summer St., Fitchburg,
Mass.

ARAUCARIAS

Godfrey Aschmann, 1012 Ontario St.,
Philadelphia, Pa.
For page see List of Advertisers.

ASPARAGUS

A. N. Pierson, Cromwell, Conn.
Asparagus Plumosus Nanus.

Asparagus Plumosa, 2 in. pots. Fine
plants, \$3.00 per 100; \$25.00 per 1000. Cash
with order or good reference. Erie Floral
Co., Erie, Pa.; or, Wm. F. Kastlag Co.,
385 Elliott St., Buffalo, N. Y.

AUCTION SALES

Cleary's Horticultural Co., 62 Vesey St.,
New York.
Horticultural Products of Every Description.

For page see List of Advertisers.

Sales every Tuesday and Friday. If you
cannot attend send bids and shipping in-
structions. Catalogues on application. N.
F. McCarthy & Co., 84 Hawley St., Bos-
ton.

AZALEAS

A. Leuthy & Co., Perkins St. Nurseries,
Roslindale, Mass.
For page see List of Advertisers.

W. W. Edgar Co., Waverley, Mass.

For page see List of Advertisers.

August Rolker & Sons, New York, 31 Bar-
clay St., or P. O. Box 752.
For page see List of Advertisers.

BAMBOO CANES

Stump & Walter Co., 50 Barclay St.,
New York.

For page see List of Advertisers.

Yokohama Nursery Co., 31 Barclay Street,
New York.

For page see List of Advertisers.

Schlegel & Fottler Co., 26 27 So. Market St.,
Boston, Mass.
For page see List of Advertisers.

BASKETS

Coles & Co., 109 & 111 Warren St., New
York.
Baskets for Florists: Berry Baskets: Fruit
Packages.

BAY TREES.

Specimens and pairs, all sizes. Send for
prices. N. F. McCarthy & Co., 84 Hawley
St., Boston.

Bay Trees and Box Trees, standards and
pyramids. All sizes. Price list on appli-
cation. J. Roehrs Co., Rutherford, N. J.

BEDDING PLANTS

R. Vincent, Jr., & Sons Co., White Marsh,
Maryland.
For page see List of Advertisers.

BEGONIAS

J. A. Peterson, McHenry Ave., Westwood,
Cincinnati, Ohio.
Begonia Gloire De Lorraine.

BOILERS

BOILERS. "Burnham" Boilers made for
greenhouse heating. Lord & Burnham,
1133 Broadway, N. Y.

BOXWOOD

Henry M. Roblason & Co., 15 Province St.,
Boston.

For page see List of Advertisers.

N. F. McCarthy & Co., 84 Hawley St.,
Boston, Mass.

For page see List of Advertisers.

BUILDING MATERIAL

BUILDING MATERIAL of all descrip-
tion for All Cypress, Semi-Iron, Iron
Frame or Truss Houses. Hot Bed Sash
and Frames. Lord & Burnham Co., 1133
Broadway, N. Y.

BULBS AND TUBERS

Joseph Breck & Sons, 47-54 N. Market St.,
Boston.

For page see List of Advertisers.

J. M. Thorburn & Co., 33 Barclay St.,
New York.

For page see List of Advertisers.

A. T. Boddington, 342 W. 14th St., N. Y.
For page see List of Advertisers.

Rickards Bros., 37 East 19th St., New York.
For page see List of Advertisers.

H. F. Mitchell Co., Philadelphia.

For page see List of Advertisers.

H. E. Fiske Seed Co., Faneuil Hall Sq.,
Boston.

For page see List of Advertisers.

James Vick's Sons, Rochester, N. Y.
Fall Bulbs.

For page see List of Advertisers.

D. Rusconi, 128 W. Sixth St., Cincinnati, O.
Lillum Auratum, Rozeum, Multiflorum.

For page see List of Advertisers.

Aug. Rolker & Sons, 31 Barclay St., New
York.

Seasonable Import Plants and Bulbs.

For page see List of Advertisers.

K. Velthuis, Hillegom, Holland,
Represented by Felix Bosch, 260 Clarendon
St., Boston.

Bulbs French and Dutch.

For page see List of Advertisers.

Ralph M. Ward & Co., 2 W. Broadway,
New York, Agts. for Martial Bremond,
Ollioules, France.

French Bulbs.

For page see List of Advertisers.

Yokohama Nursery Co., 31 Barclay St.,
New York.

Formosa Lilium Longiflorum.

For page see List of Advertisers.

Henry A. Dreer, 714 Chestnut St.,
Philadelphia.

Calla Elliottiana, Caladims.

For page see List of Advertisers.

Stump & Walter Co., 50 Barclay St.,
New York.
Canna Bulbs.

For page see List of Advertisers.

Dwarf Pearl tuberose, 50,000 No. 2, very
fine bulbs, 4 in. in circumference. Write
for prices. T. V. Rivenbark, Wallace,
N. C.

25 Lily of Valley, postpaid, 80 cts.; 200
Dunlap, Warfield Strawberry plants, post-
paid, \$1.25. Catalogue free. Alva Y.
Cathcart, Bristol, Indiana.

CANNAS

The Conard & Jones Co., West Grove, Pa.
For page see List of Advertisers.

A. T. Boddington, 342 W. 14th St.,
New York.

For page see List of Advertisers.

Henry A. Dreer, 714 Chestnut St.,
Philadelphia

For page see List of Advertisers.

Good Robusta, dark-leaved, at \$1.50
per 100; large clumps Burbank, Mlle.
Berat and Cinnebar, at \$2.00 per 100;
Pennsylvania, at \$2.50 per 100. C. W.
Moeckel, 17 Summer St., Fitchburg, Mass.

CARNATIONS

F. Doraer & Sons Co., Lafayette, Ind.
For page see List of Advertisers.

S. S. Skidelsky, 1741 N. 18th St., Phila-
delphia.

For page see List of Advertisers.

Chicago Carnation Co., Joliet, Ill.

For page see List of Advertisers.

F. R. Pierson Co., Tarrytown, N. Y.
Winsor and White Enchantress Rooted
Cuttings.

For page see List of Advertisers.

H. A. Jahn, New Bedford, Mass.
Carnation Lloyd.

For page see List of Advertisers.

John E. Haines, Bethlehem, Pa.
Carnations Imperial and Pink Imperial.

For page see List of Advertisers.

The Leo Nlessen Co., 1209 Arch St.,
Philadelphia, Pa.

For page see List of Advertisers.

White Bros., Gasport, N. Y.
Winsor, White Enchantress.

For page see List of Advertisers.

Chas. H. Totty, Madison, N. J.

For page see List of Advertisers.

F. H. Kimberly, 631 Townsend Ave.,
New Haven, Conn.

Fair Maid Carnation cuttings, strong.
\$1.60 per 100; 500 for \$7.50. C. W. Moeckel,
17 Summer St., Fitchburg, Mass.

Send for list of the best carnation cut-
tings. Wm. Ehmann, Jr., Corfu, N. Y.

Carnation cuttings of all the leading
varieties at the same price as any reliable
firm. Write for prices before you look
elsewhere. Wm. F. Kastlag Co., 383
Elliott St., Buffalo, N. Y.

CHRYSANTHEMUMS

Chas. H. Totty, Madison, N. J.
Single Chrysanthemums.

For page see List of Advertisers.

Elmer D. Smith & Co., Adrian, Mich.
Novelty Chrysanthemums.

For page see List of Advertisers.

Will have 100,000 rooted cuttings of the
best 60 commercial varieties ready about
March 25. Have your orders booked now.
Postal will bring new price list. Satisfac-
tion guaranteed. W. Ehmann, Corfu, N. Y.

CONFISERS

John Waterer & Sons, Ltd., American
Nursery, Bagshot, Eng.

For page see List of Advertisers.

Write for prices on all choice ornamental
confisera. N. F. McCarthy & Co., 84 Haw-
ley St., Boston, Mass.

CUT FLOWER BOXES.

Edwards Folding Box Co., Philadelphia.

For page see List of Advertisers.

Folding cut flower boxes, the best made.
Write for list. Holton & Hunkel Co., Mil-
waukee, Wis.

DAHLIAS

David Herbert & Son, Atco, N. J.
For page see List of Advertisers.

J. L. Moore, Northboro, Mass.

For page see List of Advertisers.

Henry A. Dreer, 714 Chestnut St.,
Philadelphia.

Dahlia Souvenir de Gustave Doazon.

For page see List of Advertisers.

15,000 Field-grown clumps 2c. and up.
List ready. H. W. Koerner, Sta. B, Mil-
waukee, Wis.

Dahlia Roots—Undivided field clumps,
Lyndhurst, Maid of Kent, William Agnew,
White Swan, Kreinhilde, John Walker,
Arabella and A. D. Livoni. Write for
low prices. Wood & Healey, Hammonton,
New Jersey.

For List of Advertisers See Page 316

DAHLIAS — Continued

Cactus, Decorative, Show, Fancy and Pompon Dahlias. 75 leading varieties to select from. Strong divided clumps, in 10 or 20 varieties, my selection at \$3.00 per 100; \$25.00 per 1000. Single Dahlias, mixed, \$1.00 per 100. Cash with order please. Hermann Thiemann, Monson, Mass.

DECORATIVE PLANTS

A. Lenthy & Co., Roslindale, Mass.
For page see List of Advertisers.

EASTER PLANTS

Wm. W. Edgar Co., Waverley, Mass.
For page see List of Advertisers.

A. Lenthy & Co., Perkins St. Nurseries, Roslindale, Mass.
For page see List of Advertisers.

EUONYMUS RADICANS

Euonymus radicans, 1-1 1/2 ft., \$6.00; 2-2 1/2 ft., \$8.00 per 100. Bushy plants. Brae-Burn Nursery, West Newton, Mass.

EVERGREENS

The New England Nurseries, Bedford, Mass.
For page see List of Advertisers.

FERNS

A. Lenthy & Co., Roslindale, Mass.
For page see List of Advertisers.

H. H. Barrows & Son, Whitman, Mass
Nephrolepis Whitman.
For page see List of Advertisers.

Godfrey Aachmann, 1012 Ontario St., Philadelphia, Pa.
For page see List of Advertisers.

John Scott, Brooklyn, N. Y.
For page see List of Advertisers.

Baur Floral Co., Erie, Pa.
For page see List of Advertisers.

Nephrolepis Exaltata Bostoniensis, fine young plants, \$10.00 per 1000.
N. Elegantissima, young plants \$15.00 per 1000. Send for price list. Soar Bros. Little River, Fla.

FERTILIZERS

Pulvertized Manure Co., 31 Union Stock Yards, Chicago, Ill.
Wizard Brand Cattle Manure.
For page see List of Advertisers.

Thos. J. Grey & Co., 32 and 33 South Market St., Boston.
High-Grade Scotch Soot.
For page see List of Advertisers.

Schlegel & Pottler Co., 25-27 So. Market St., Boston, Mass.
Scotch Soot.
For page see List of Advertisers.

FLORAL PHOTOGRAPHS

Floral Photographs. Foley's 226-228 1-2 Bowery, New York.

FLORISTS' LETTERS.

Boston Florist Letter Co., 66 Pearl St., Boston, Mass.
For page see List of Advertisers.

Koral Mfg. Co., 26 Hawley St., Boston.
For page see List of Advertisers.

FLORISTS SUPPLIES

H. M. Robinson & Co., 15 Province St. and 9 Chapman Pl., Boston, Mass.
For page see List of Advertisers.

The Keivan Co., 113 W. 28th St., N. Y.
Decorative Evergreens.
For page see List of Advertisers.

Reed & Keller, 122 W. 25th St., New York.
For page see List of Advertisers.

J. B. Murdoch & Co., 714 Penn Ave., Pittsburg, Pa.
For page see List of Advertisers.

H. Bayersdorfer & Co., 1129 Arch St., Philadelphia.
For page see List of Advertisers.

Alex. Mann, Jr., Co., 1125 Polk St., San Francisco, Calif.
For page see List of Advertisers.

FLOWERS BY TELEGRAPH

Park Floral Co., Denver, Colo.
For page see List of Advertisers.

J. N. Champlon & Co., 1026 Chapel St., New Haven, Conn.
For page see List of Advertisers.

George H. Cooke, Washington, D. C.
For page see List of Advertisers.

FLOWERS BY TELEGRAPH —

Continued

Gude Bros. Co., 1214 F St., Washington, D. C.
For page see List of Advertisers.

Atlanta Floral Co., Atlanta, Ga.
For page see List of Advertisers.

P. J. & J. E. Hauswirth, 232 Michigan Ave., Chicago.
For page see List of Advertisers.

William J. Smyth, Michigan Ave. and 31st St., Chicago.
For page see List of Advertisers.

Jacob Schulz, 614 4th Ave., Louisville, Ky.
For page see List of Advertisers.

Thos F. Galvin, 124 Tremont St., Boston.
For page see List of Advertisers.

Julius A. Zinn, 2 Beacon St., Boston.
For page see List of Advertisers.

Houghton & Clark, 396 Boylston St., Boston.
For page see List of Advertisers.

Sidney Hoffman, 59-61 Massachusetts Ave., Boston.
For page see List of Advertisers.

Edward MacMulkin, 194 Boylston St., Boston.
For page see List of Advertisers.

J. Brettmeier's Sons, Miami and Grailot Aves., Detroit, Mich.
For page see List of Advertisers.

Samuel Murray, 1017 Broadway, Kansas City, Mo.
For page see List of Advertisers.

Wm. L. Rock Flower Co., 1116 Walnut St., Kansas City, Mo.
For page see List of Advertisers.

Fred C. Weber, 4326-28 Olive St., St. Louis, Mo.
For page see List of Advertisers.

H. G. Eyrea, 11 N. Pearl St., Albany, N. Y.
For page see List of Advertisers.

David Clarke's Sons, 2159-2141 Broadway, New York.
For page see List of Advertisers.

W. H. Donohoe, 17 E. 28th St., New York.
For page see List of Advertisers.

Alex. McConoell, New York.
For page see List of Advertisers.

Robert G. Wilson, Fulton St. & Greene Av., Brooklyn, N. Y.
For page see List of Advertisers.

Thomas Young, Jr., 500 Fifth Ave., N. Y.
For page see List of Advertisers.

Young & Nugent, 42 W. 28th St., N. Y.
For page see List of Advertisers.

FLOWER POTS

W. H. Ernest, 25th and M Sts., Washington, D. C.
For page see List of Advertisers.

A. H. Hews & Co., Cambridge, Mass.
For page see List of Advertisers.

Hilfinger Bros., Ft. Edward, N. Y.
For page see List of Advertisers.

Paper pots for all early vegetables. Two inch pots \$1.00 a thousand; three inch \$1.25; four inch \$1.60. P. B. Crosby, Catonsville, Md.

GALAX

Michigan Cut Flower Co., 38 and 40 Broadway, Detroit, Mich.
For page see List of Advertisers.

Finest green and bronze Galax in any quantity at lowest figures. N. F. McCarthy, 84 Hawley St., Boston.
For page see List of Advertisers.

GERANIUMS

R. Vincent Jr. & Sons Co., White Marsh, Md.
New and Standard Varieties.
For page see List of Advertisers.

Geraniums, surplus of Nutt, Doyle and Buchner, 2 in. pots, \$15.00 per 1000. Cash with order. Ernest Harris, Delanson, N. Y.

GLADIOLI

Arthur Cowee, Meadowvale Farm, Berlin, New York.
For page see List of Advertisers.

J. L. Moore, Northboro, Mass.
For page see List of Advertisers.

I. & J. L. Leonard, Iona, N. J.
Gladiolus Bulbs.
For page see List of Advertisers.

GLADIOLI — Continued

John Lewis Childs, Floral Park, N. Y.
Gladiolus America.

Gladioli. Write for leaflet. B. Hammond Tracy, Cedar Acres, Wenham, Mass.

Gladioli. Named varieties and mixtures. Send for list. E. E. Stewart, Rives Junction, Mich.

GLASS

Boston Plate & Window Glass Co., Boston.
For page see List of Advertisers.

Standard Plate Glass Co., 26-30 Sudbury St., Boston.
For page see List of Advertisers.

S. Jacobs & Sons, 1365-79 Flushing Ave., Brooklyn, N. Y.
For page see List of Advertisers.

Metropolitan Material Co., 1398-1408 Metropolitan Ave., Brooklyn, N. Y.

Foley Mfg. Co., between Western Ave. and 26th St., Chicago, Ill.

GLASS, High Grade, Double Thick Greenhouse Glass. Lord & Burnham, 1133 Broadway, N. Y.

GLAZING POINT

H. A. Dreer, Philadelphia, Pa.
For page see List of Advertisers.

GLAZING POINTS, Lord & Burnham Special Glazing Nails (Points). Lord & Burnham, 1133 Broadway, N. Y.

GREENHOUSE BUILDING MATERIAL.

Lord & Burnham Co., 1133 Broadway, New York.
For page see List of Advertisers.

Pleron U-Bar Co., 1 Madison Sq., N. Y.
For page see List of Advertisers.

A. T. Stearna Lumber Co., Neponset, Boston.
For page see List of Advertisers.

King Construction Co., N. Tonawanda, New York.
For page see List of Advertisers.

J. C. Moulnger Co., 117 East Blackhawk St., Chicago, Ill.
For page see List of Advertisers.

Foley Mfg. Co., between Western Ave. and 26th St., Chicago, Ill.
For page see List of Advertisers.

I. Cassidy, Summer Ave. and Erie R. R., Newark, N. J.
For page see List of Advertisers.

W. H. Lutton, Jersey City, N. J.
For page see List of Advertisers.

Geo. B. Doane, 18 Midway St., Boston.
Iron Pipe.
For page see List of Advertisers.

S. Jacobs & Sons, 1365-79 Flushing Ave., Brooklyn, N. Y.
For page see List of Advertisers.

Metropolitan Material Co., 1398-1408 Metropolitan Ave., Brooklyn, N. Y.

Hitchhogs & Co., 1170 Broadway, N. Y.

GREENHOUSE CONSTRUCTION

GREENHOUSE CONSTRUCTION, Semi-Iron Greenhouse, New Truss Houses and Iron Frame Houses. Lord & Burnham, 1133 Broadway, N. Y.

J. A. Payne, 260-274 Culver Ave., Jersey City, N. J.
For page see List of Advertisers.

I. Cassidy, Summer Ave. and Erie R. R., Newark, N. J.
For page see List of Advertisers.

Foley Mfg. Co., between Western Ave. and 26th St., Chicago, Ill.

W. H. Lutton, Jersey City, N. J.
For page see List of Advertisers.

GREENHOUSE HOSE

Mineralized Rubber Co., 18 Cliff St., N. Y.
For page see List of Advertisers.

GUTTERS

GUTTERS, Coat Iron Gutters, L. & B. Improved V Shaped Gutter with drip gutter attachment. Lord & Burnham, 1133 Broadway, N. Y.

HAIL INSURANCE

Florists' Hall Asso. of America.
J. G. Esler, Saddle River, N. J.
For page see List of Advertisers.

In writing to Advertisers kindly mention Horticulture

HARDY FERNS AND SUPPLIES

H. M. Robinson & Co., 15 Province St. and 9 Chapman Pl., Boston, Mass.
For page see List of Advertisers

The Keivan Co., 115 W. 28th St., N. Y.
For page see List of Advertisers.

Michigan Cut Flower Exchange,
38 and 40 Broadway, Detroit, Mich.
Fancy Ferns.

For page see List of Advertisers.

A full line of ferns, galax, and all wild greens. N. F. McCarthy & Co., 84 Hawley St., Boston.

For page see List of Advertisers.

HEATING APPARATUS

Lord & Burnham Co.,

1133 Broadway, New York.
For page see List of Advertisers.

Pierson U-Bar Co., 1 Madlaon Sq., N. Y.
For page see List of Advertisers.

John A. Payne, 260-274 Culver Ave., Jersey City, N. J.

For page see List of Advertisers.

Hitchings & Co., 1170 Broadway, N. Y.

HELP FURNISHED

Thos. H. Bambrick, 34 S. 7th St., Phila.
For page see List of Advertisers.

HERBACEOUS PERENNIALS

Red Oak Nurseries, Fiskeville, R. I.
For page see List of Advertisers.

HOT-BED MATS

G. H. Frost, W. Newton, Mass.
For page see List of Advertisers.

HOT-BED SASH

The A. T. Stearns Lumber Co., Neponset, Mass.

For page see List of Advertisers.

Pierson U-Bar Co., 1 Madison Sq., N. Y.
For page see List of Advertisers.

Lord & Burnham Co., 1133 Broadway, N. Y.
For page see List of Advertisers.

Hitchings & Co., 1170 Broadway, N. Y.

Foley Mfg. Co., between Western Ave. and 26th St., Chicago, Ill.

INSECTICIDES.

Nicotinide kills all greenhouse pests.

P. R. Palethorpe Co.,
Eleventh St., Owensboro, Ky.

For page see List of Advertisers.

B. G. Pratt Co., 11 Broadway, New York.
For page see List of Advertisers.

JAPANA CUT FLOWER HOLDER

M. V. Garusey, 130 Walola Ave.,
La Grange, Ill. Dept. M.

For page see List of Advertisers.

KENTIAS

A. Leuthy & Co., Roslindale, Mass.
For page see List of Advertisers.

Godfrey Aschmann, 1012 W. Ontario St.,
Philadelphia.

For page see List of Advertisers.

LEADING RETAIL FLORISTS

Park Floral Co., Denver, Colo.
For page see List of Advertisers.

George H. Cooke, Washington, D. C.
For page see List of Advertisers

Gude Bros. Co., 1214 F St.,
Washington, D. C.

For page see List of Advertisers

Atlanta Floral Co., Atlanta, Ga.

For page see List of Advertisers.

P. J. & J. E. Hauswirth, 232 Michigan Ave.,
Chicago.

For page see List of Advertisers

William J. Smyth, Michigan Ave. and 31st
St., Chicago.

For page see List of Advertisers

Jacob Schelz, 644 4th Ave., Louisville, Ky.
For page see List of Advertisers

Thos. F. Galvin, 124 Tremont St., Boston.

For page see List of Advertisers

Julius A. Zinn, 2 Beacon St., Boston.

For page see List of Advertisers.

Houghton & Clark, 396 Boylston St.,
Boston.

For page see List of Advertisers.

Sidney Hoffman, 59-61 Massachusetts Ave.,
Boston.

For page see List of Advertisers.

LEADING RETAIL FLORISTS—**Continued**

Edward MacMullkin, 194 Boylston St.,
Boston.

For page see List of Advertisers.

J. Bretmeyer's Sons, Detroit, Mich.

For page see List of Advertisers.

Samuel Murray, 1017 Broadway,
Kansas City, Mo.

For page see List of Advertisers.

Wm. L. Rock Flower Co., 1116 Walnut
St., Kansas City, Mo.

For page see List of Advertisers.

Fred C. Weber, 4326 Olive St., St. Louis,
Mo.

For page see List of Advertisers.

J. N. Champion & Co., 1026 Chapel St.,
New Haven, Conn.

For page see List of Advertisers.

H. G. Eyres, 11 N. Pearl St., Albany, N. Y.

For page see List of Advertisers.

David Clarke's Sons, 2139-2141 Broadway,
New York.

For page see List of Advertisers

W. H. Donohoe, 17 E. 28th St., New York.

For page see List of Advertisers.

Alex. McConnell, New York.

For page see List of Advertisers

Robert G. Wilson, Fulton St. and Greene
Ave., Brooklyn, N. Y.

For page see List of Advertisers.

Thomas Young, Jr., 500 Fifth Ave., N. Y.

For page see List of Advertisers.

Young & Nugent, 42 W. 28th St., N. Y.

For page see List of Advertisers

LOBELIAS

Jos. Fuller, 31 Orchard St., Leominster,
Mass.

Carter's Double Blue Lobelia.

NEW AND RARE PLANTS

Rose Hill Nurseries, New Rochelle, N. Y.
For page see List of Advertisers.

NICO-FUME

Kentucky Tobacco Product Co.,
Louisville, Ky.

NURSERY STOCK

John Waterer & Sons, Ltd.,

American Nursery, Bagshot, England.
For page see List of Advertisers.

New England Nurseries, Bedford, Mass.
Shrubs, Roses and Herbaceous Perennials.

Specimen Pyramidal Box.

For page see List of Advertisers.

Bay State Nurseries, N. Abington, Mass.
Herbaceous Perennials, Hardy Ornamental
Trees.

For page see List of Advertisers.

Cleary's Horticultural Co., 62 Vesey St.,
New York.

For page see List of Advertisers.

P. Ouwkerk, 216 Jane St., Weehawken
Height, N. J.

Holland Nursery Stock for Forcing.

For page see List of Advertisers

American Nursery Co., 150 Broadway, New
York, N. Y.

For page see List of Advertisers.

Pierce Nurseries, Beverly Farms, Mass.
Tree Seedlings and Rooted Cuttings.

For page see List of Advertisers.

I. & J. L. Leonard, Iona, N. J.
California Privet, American Chestnuts.

For page see List of Advertisers.

Eastern Nurseries (M. M. Dawson, Mgr.),
Jamaica Plain, Mass.

Hardy Trees, Shrubs, Perennials.

For page see List of Advertisers.

D. J. Twomey, Dept. H., Geneva, N. Y.
Trees and Plants.

For page see List of Advertisers.

Nursery Stock. N. F. McCarthy & Co.,
84 Hawley St., Boston, Mass.

ORCHID PLANTS

Lager & Hurrell, Summit, N. J.
For page see List of Advertisers.

Saunders, St. Albans, England.

Importers, Exporters, Growers, Hybridists
For page see List of Advertisers.

Julius Roehrs Co., Rutherford, N. J.

For page see List of Advertisers.

Carrillo & Baldwin, Secaucus, N. J.

For page see List of Advertisers.

ORCHID PLANTS—Continued

Jos. A. Manda, 191 Valley Road, W.
Orange, N. J.

For page see List of Advertisers.

Ordonez Bros., Madison, N. J., Box 105.
For page see List of Advertisers.

PALMS

A. Leuthy & Co., Perkins St. Nurseries,
Roslindale, Mass.

For page see List of Advertisers.

Robert Craig Co., Market and 49th St.,
Philadelphia, Pa.

For page see List of Advertisers.

John Lewis Childs, Floral Park, N. Y.
Phoenix Roebelin.

Kentia, Phoenix, etc., all sizes. Write
for new price list. Julius Roehrs Co.,
Rutherford, N. J.

PAINT AND PUTTY

PAINT AND PUTTY: Ideal Greenhouse
lead; Special Greenhouse Putty. Lord &
Burnham, 1133 Broadway, N. Y.

PANSY PLANTS.

Choice pansy plants, 50c per 100; \$4.00
per 1000. Cash. Aug. Zirngelbel, Need-
ham, Mass.

PATENTS

Siggers & Siggers, Washington, D. C.
For page see List of Advertisers.

PEAT

Orchid peat, Rotted peat, Azalea peat,
Leaf-Mould, Live Sphagnum moss, Baled
Sphagnum moss, Green Clump moss, etc.
Jobbers' list on application. C. W. Brown-
ell & Co., Walden, N. Y.

PELARGONIUMS

R. Vincent, Jr. & Sons Co., White Marsh,
Maryland.

For page see List of Advertisers.

PEONIES

Wholesale Peony list for fall 1908 is now
ready. J. F. Rosenfield, West Point, Neb.

One of the finest collections in America.
Send 25 cts. in stamps for new edition of
Peony Manual. C. S. Harrison's Select
Nursery, York, Neb.

PHLOXES

Send 25 cts. in stamps for Phlox Manual.
Fine mixed phloxes \$1.50 per 100. C. S.
Harrison's Select Nursery, York, Neb.

PIPE AND FITTINGS

Foley Mfg. Co., between Western Ave. and
26th St., Chicago, Ill.

Eagle Metal & Supply Co., Johnson and
Union Aves., Brooklyn, N. Y.

Second-Hand Pipe and Boiler Tubes.

For page see List of Advertisers.

PIPE AND FITTINGS. Cast Iron and
Wrought Pipe, Valves, Elbows, Pipe Hooks,
Automatic Air Headers, etc. Lord &
Burnham, 1133 Broadway, N. Y.

PLANT BED CLOTH

Mineralized Rubber Co., 18 Cliff St., N. Y.
For page see List of Advertisers.

POT HANGERS

Pot hangers, Kramer's \$1 doz. by exp.,
\$1.25 by mail. I. N. Kramer & Son, Cedar
Rapids, Ia.

PRUNING SHEARS

Rhodes Mfg. Co., Grand Rapids, Mich.
Dept. R.

For page see List of Advertisers.

RAFFIA

Raffia (colored), 20 beautiful shades
Samples free. R. H. Coney Co., Camden,
N. J.; 810 Washburn Ave., Chicago, Ill.

RHODODENDRONS

John Waterer & Sons, Ltd.,
American Nursery, Bagshot, England.

For page see List of Advertisers.

ROSES

Julius Roehrs Co., Rutherford, N. J.
Rambler Rose, Newport Fairly.

For page see List of Advertisers.

New England Nurseries, Inc., Bedford,
Mass.

For page see List of Advertisers.

Bay State Nurseries, N. Abington, Mass.
For page see List of Advertisers.

For List of Advertisers See Page 316

ROSES—Continued

Ellwanger & Barry, Rochester, N. Y.
Hardy Roses.
For page see List of Advertisers.

John Cook, 318 Charles St., N. Baltimore, Maryland.
Rose My Maryland.
For page see List of Advertisers.

Robert Craig Co., Market and 49th Sts., Philadelphia, Pa.
For page see List of Advertisers.

Dingee-Conard Co., West Grove, Pa.
New Climbing Rose, Tausendschon.
For page see List of Advertisers.

400 varietles; own roots; summer grown.
Leedle Company, Springfield, Ohio.

Crimson Ramblers, 2 year, on own roots, extra strong, at 7 cents. Gilbert Costich, Rochester, N. Y.

Low-budded roses, No. 1, \$95.00; No. 1-2, \$65.00 1000. H. T. Jones, Elizabeth, N. J.

The beautiful new pink rose, MISS KATE MOULTON is the queen of all pink roses. It's a winner and you should grow it. Price \$30.00 100; 500 \$125.00; 1000 \$200.00; 5000 and upwards \$175 per 1000. Minneapolis Floral Co., Minneapolis, Minn.

SCALECID

B. G. Pratt Co., 11 Broadway, New York.
For page see List of Advertisers.

SEEDS

T. J. Grey Co., 32 So. Market St., Boston, Mass.
For page see List of Advertisers.

Joseph Breck & Sons,
51 and 52 N. Market St., Boston, Mass.
For page see List of Advertisers.

W. Atlee Burpee & Co., Philadelphia.
For page see List of Advertisers.

J. M. Thorburn & Co., 33 Barclay St., N. Y.
For page see List of Advertisers.

A. T. Boddington, 342 W. 14th St., N. Y.
For page see List of Advertisers.

H. F. Michell Co., 1017 Market St., Phila.
For page see List of Advertisers.

James Vick's Sons, Rochester, N. Y.
Vick's Superb Pansy Seed.
For page see List of Advertisers.

Hjalmar Hartmann & Co.,
12 Stormgade, Copenhagen, Denmark.
Cauliflower and Cabbage Seed.
For page see List of Advertisers.

Rickards Bros., 37 E. 19th St., New York.
For page see List of Advertisers.

R. & J. Farquhar & Co., 6-7 So. Market St., Boston.
Giant Cyclamen Seed.
For page see List of Advertisers.

C. C. Morse & Co., 48-56 Jackson St., San Francisco, Cal.
For page see List of Advertisers.

H. E. Fiske Seed Co., Faneuil Hall Sq., Boston.
For page see List of Advertisers.

Braslan Seed Growers Co., San Jose, Cal.
For page see List of Advertisers.

O. V. Zangen, Hoboken, N. J.
For page see List of Advertisers.

R. Wibolt, Nakskov, Denmark.
Snowball Cauliflower Seed.
For page see List of Advertisers.

Stmupp & Walter Co., 50 Barclay St., New York.
For page see List of Advertisers.

Schlegel & Fottler Co., 26 & 28 So. Market St., Boston.
Cyclamens, Asparagus and Summer Flowering Bulbs and Roots.
For page see List of Advertisers.

Altimo Culture Co., Canfield, O.
Aster Seed.
For page see List of Advertisers.

Crego aster seed. Ask for circular. G. S. Crego, Maywood, Ill.

500 bu. choice Canada cluster Oats (weigh 40 lbs.); 250 bu. choice two-row Barley; field and garden seeds of all kinds. The Bell Seed Co., Manlius, N. Y.

SHAMROCKS

John F. Rupp, Shiremanstown, Pa.
For page see List of Advertisers.

N. F. McCarthy & Co., 84 Hawley St., Boston.
For page see List of Advertisers.

SMILAX

E. A. Beaven, Evergreen, Ala.
Southern Wild Smilax; Log Mosaes.
For page see List of Advertisers.

SPHAGNUM MOSS

Live Sphagnum moss, orchid peat and orchid baskets always on hand. Lager & Hurrell, Summit, N. I.

STEAM TRAP

E. Hippard, Youngstown, O.

TOBACCO STEMS

Wm. Elliott & Sons, 201 Fulton St., New York.

VEGETABLE PLANTS

A few millions Frost Proof Cabbage Plants of all the best varieties at \$1.25 per 1,000; \$1 per 1,000 above 5,000. Express at Charleston, S. C. Special price for large lots. Rates on plants very low. Alfred Jouannet, Mt. Pleasant, S. C.

VENTILATING APPARATUS

Pierson U-Bar Co., 1 Madison Sq., N. Y.
For page see List of Advertisers.

Foley Mfg. Co., between Western Ave. and 26th St., Chicago, Ill.
For page see List of Advertisers.

John A. Payne, 260-274 Culver Ave., Jersey City, N. J.
For page see List of Advertisers.

Hitchings & Co., 1170 Broadway, N. Y.

VENTILATING MACHINERY, New Model encased, self-oiling gear; Standard Model Open Gear. Lord & Barnham, 1133 Broadway, N. Y.

VIOLETS

William Sim, Cliftondale, Mass.
Violet Boston.
For page see List of Advertisers.

Violet cuttings, "Marla Louisa" Rhinebeck stock, rooted runners, May delivery \$20.00 M. Immediate delivery, between now and March 15th, \$10.00 M. Wm. F. Kasting Co., 383 Ellicott St., Buffalo, N. Y.

WIREWORK

Reed & Keller, 122 W. 25th St., N. Y.
For page see List of Advertisers.

Wirework. Write for our catalogue. Holton & Hunkel Co., Milwaukee, Wis.

William E. Hellacher's Wire Works, 38-40 Broadway, Detroit, Mich.

The "Just Right" kind. Send for price list. Frank W. Ball, 31 East Third Street, Cincinnati, O.

WHOLESALE FLORISTS

Boston

N. F. McCarthy & Co., 84 Hawley St., Boston.
For page see List of Advertisers.

H. M. Robinson & Co., 15 Province St. and 9 Chapman Pl., Boston.
For page see List of Advertisers.

Welch Bros., 226 Devonshire St., Boston.
For page see List of Advertisers.

Buffalo

Wm. F. Kasting Co., 383-87 Ellicott St., Buffalo, N. Y.
For page see List of Advertisers.

Chicago

Chas. W. McKellar, 51 Wabash Ave., Chicago.
For page see List of Advertisers.

Peter Reinberg, 51 Wabash Ave., Chicago.
For page see List of Advertisers.

E. F. Winterson Co., 45-49 Wabash Ave., Chicago.
For page see List of Advertisers.

Detroit

Michigan Cut Flower Exchange, 38 and 40 Broadway, Detroit, Mich.
For page see List of Advertisers.

WHOLESALE FLORISTS—

Continued

New York

J. K. Allen, 106 W. 25th St., New York.
For page see List of Advertisers.

J. S. Fenrich, 110 W. 28th St., New York.
For page see List of Advertisers.

Ford Bros., 48 W. 28th St., New York.
For page see List of Advertisers.

H. E. Froment, 57 W. 25th St., New York.
For page see List of Advertisers.

Alex. J. Guttman, 43 W. 28th St., New York.
For page see List of Advertisers.

E. C. Horan, 55 W. 28th St., New York.
For page see List of Advertisers.

A. H. Langjahr, 55 W. 28th St., New York.
For page see List of Advertisers.

James McManus, 42 W. 28th St., New York.
For page see List of Advertisers.

John J. Raynor, 49 W. 28th St., New York.
For page see List of Advertisers.

W. F. Sheridan, 39 W. 28th St., New York.
For page see List of Advertisers.

Traendly & Schneck, 44 W. 28th St., New York.
For page see List of Advertisers.

John Young, 51 W. 28th St., New York.
For page see List of Advertisers.

Moore, Hentz & Nash, 55 and 57 W. 26th St., New York.
For page see List of Advertisers.

Frank S. Hicks & Co., 52 W. 28th St., New York.
For page see List of Advertisers.

Frank Millaug, 57 W. 26th St., New York.
For page see List of Advertisers.

Wm. H. Kuebler, 28 Willoughby St., Brooklyn, N. Y.
For page see List of Advertisers.

Phillip F. Kessler, 55 and 57 W. 26th St., New York.
For page see List of Advertisers.

A. Moltz, 55-57 W. 26th St., New York.
For page see List of Advertisers.

B. S. Shan, Jr., 55 W. 26th St., New York.
For page see List of Advertisers.

Milling Bros., 41 W. 28th St., New York.
For page see List of Advertisers.

Philadelphia

W. E. McKissick, 1619-1621 Ranstead St., Philadelphia, Pa.
For page see List of Advertisers.

Leo Niessen Co., 1209 Arch St., Philadelphia, Pa.
For page see List of Advertisers.

The S. S. Pennock-Meehan Co., 1608-18 Ludlow St., Philadelphia, Pa.
For page see List of Advertisers.

Edward Reid, 1526 Ranstead St., Philadelphia, Pa.
For page see List of Advertisers.

Pittsburg

J. B. Murdoch & Co., 714 Penn Ave., Pittsburg, Pa.
For page see List of Advertisers.

Providence, R. I.

J. Kopelman & Co., 21 Washington St., Providence, R. I.
For page see List of Advertisers.

San Francisco

Alex. Mann, Jr., Co., 1125 Polk St., San Francisco, Cal.
For page see List of Advertisers.

St. Louis

H. G. Berning, 1402 Pine St., St. Louis, Mo.
For page see List of Advertisers.

Washington, D. C.

J. J. Harty & Co., 1312 G. St. N. W., Washington, D. C.
For page see List of Advertisers.

WHOLESALE PLANTSMAN

Samuel A. Woodrow, 53 W. 30th St., New York.
For page see List of Advertisers.

In writing to Advertisers kindly mention Horticulture

List of Advertisers

Allen J. K.	Page 110	Lord & Burnham Co.	Page 220
Altun Culture Co.	103	Lutton W. H.	219
Americo Nursery	290	Maoda Jos. A.	305
Americo Nursery Co.	292	Mann, Alex. Jr. Co.	309
Aschmann Godfrey.	210	MacMullen E. A.	300
Atlanta Floral Co.	307	McCarthy N. F. & Co.	311-317
Bambrick Thos. H.	312	McConnell Alex.	307
Barrows H. H. & Son.	305	McKellar Charles W.	308
Barr Floral Co.	305	McKissick, W. E.	308
Bayersdorfer H. & Co.	308	McManus Jas.	302
Bay State Nurseries.	292	Michell H. F. Co.	302
Beaven E. A.	309	Michigan Cut Flower Exchange.	311
Berning H. G.	311	Millang Bros.	311
Boddington A. T.	390	Millang Frank.	311
Boston Florist Letter Co.	317	Mineralized Rubber Co.	319
Boston Plate and Window Glass Co.	318	Moltz, A.	314
Bosch, Felix.	302	Mooring J. C.	319
Bowe, M. A.	306	Moore, Hentz & Nash.	314
Braslan Seed Growers Co.	303	Moore, J. L.	304
Breck Joseph & Sons.	303	Morris Nursery Co.	292
Breitmeyer's J. Sons.	307	Morse C. C. & Co.	303
Bremood Martell.	317	Murdoch J. B. & Co.	309
Bridgeman's Seed Warehouse.	303	Murray Samuel.	307
Burpee W. A. & Co.	303	New England Nurseries.	302
Brill Francis.	303	Niesse Leo. Co.	291
Carrillo & Baldwin.	305	Ordenez Bros.	305
Cassidy J.	319	Ouwkerk P.	292
Champion J. N. & Co.	306	Palethorpe P. R. Co.	318
Chicago Carnation Co.	291	Park Floral Co.	307
Clarke's David, Sons.	307	Payoe John A.	318
Clarke's Horticultural Co.	311	Peanock-Meehan Co.	308
Conard & Jones Co.	290	Perkins St Nurseries.	291
Cook John.	292	Pierson, A. N.	304
Cooke G. H.	307	Pierson F. R. Co.	291
Cousins Leonard Jr.	295	Pierson U Bar Co.	320
Covee A.	352	Pratt B. G. Co.	318
Craig, Robt. Co.	290	Pulverized Manure Co.	318
Crawford M. & Co.	302	Raynor John I.	310
Dawson, M. M.	292	Red Oak Nurseries.	299
Dingee & Conard Co.	292	Reed & Keller.	310
Duane Geo. B. & Son.	310	Reid Edw.	308
Donohoe W. H.	307	Reinberg Peter.	308
Dorner F. Sons & Co.	291	Rhodes Mig. Co.	318
Dreer H. A.	318-19	Ribsam Carlman.	292
Dysart R. J.	309	Rickards Bros.	303
Eagle Metal & Supply Co.	318	Robinson H. M. & Co.	314
Eastern Nurseries.	292	Rock Wm. L. Flo. Co.	307
Edgar, W. W. Co.	308	Roehrs Julius Co.	292
Edwards Folding Box Co.	305	Rolker August & Sons.	318
Elliott Wm. & Sons.	302-302	Rose Hill Nurseries.	304
Ellianger & Barry.	292	Rupp J. F.	305
Elmsford Nurseries.	304	Rusconi D.	310
Esler J. G.	318	Saader & Son.	305
Ernest W. H.	318	Schlegel & Fottler Co.	303
Eyres.	307	Schulz Jacob.	307
Farquhar R. & J. Co.	305	Scott Bros.	304
Fenrich J. S.	300	Scott, John.	305
Fiske, H. E. Seed Co.	303	Sheridan W. F.	310
Foley Mig. Co.	310	Siggers & Siggers.	310
Ford Bros.	310	Stm. Wm.	304
Froment H. E.	310	Situations & Wants.	310
Frost G. H.	310	Skidelsky S. S.	291
Galvin Thos. F.	306	Slina B. S. Jr.	310
Garnsey M. V.	317	Smith Elmer D & Co.	304
Grey T. J. Co.	302	Smith H. J.	309
Gude Bros. Co.	307	Smyth Wm. J.	307
Guttman Alex. J.	310	Standard Plate Glass Co.	310
Haerens A.	290	Stearns A. T. Lumber Co.	319
Hall Asso.	318	Stumpp & Walter Co.	290-303
Haines, J. E.	291	Thorburn J. M. & Co.	303
Hartmann Hjalmar & Co.	303	Totty Chas. H.	291
Harty, Jas. J. & Co.	305	Traendly & Schenck.	310
Hauswirth P. J. & J. E.	307	Twomey D. J.	292
Herbert David & Son.	291	Valentine, J. A.	307
Hews A. H. & Co.	318	Velthuis K.	305
Hicks Frank S. & Co.	311	Vick's Jas. Sons.	303
Hilfinger Bros.	318	Vicent R. Jr. & Sons.	297
Hoffman.	306	Ward R. M. & Co.	317
Horan E. C.	310	Waterer John & Sons.	299
Houghton & Clark.	307	Watkins & Simpson.	301
Jacobs S. & Sons.	310	Weber F. C.	307
Jaho, H. A.	291	Weeber & Don.	303
Kasting W. F.	311	Welch Bros.	308
Kervan Co. The.	306	White Bros.	291
Kessler, P. F.	310	Wibolt, R.	303
Kibbe Chas. A.	301	Wilson.	309
King Cons. Co.	310	Wioterson, E. F. Co.	308
Koelman J. & Co.	301	Woodrow, Sam'l A.	311
Koral Mig Co.	317	Yokohama Nursery Co.	298-305
Kramer Bros Fdy Co.	311	Young John.	310
Kuebler Wm H.	311	Young, Thos Jr.	307
Lager & Hurrell.	305	Young & Nugent.	307
Langjahr Alfred H.	311	Zanger O. V.	301
Leonard J. & J.	304	Zinn, J. A.	306
Lenthay A. & Co.	290		

New Offers in This Issue.

ASP. PL. SEEDLINGS, CARNATIONS, CHRYSANTHEMUMS, COLEUS.

A. N. Pierson, Cromwell, Conn.
For page see List of Advertisers.

ASTER LADY ROOSEVELT.

Charles A. Kibbe, Elmhurst, Ill.
For page see List of Advertisers.

ASTER SEEDS, FORMOSA L. LONGIFLORUM BULBS.

Henry F. Michell Co., 1016 Market St., Philadelphia.
For page see List of Advertisers.

CALIFORNIA PRIVET, TREES, SHRUBS, BEDDING PLANTS, ETC.

Carlman Ribsam, 31 Wall St., Trenton, N. J.
For page see List of Advertisers.

COLD STORAGE LILY OF VALLEY: L. HARRISII, ETC.

J. M. Thorburn & Co., 33 Barclay St., New York.
For page see List of Advertisers.

DECORATIVE PLANTS: EASTER PLANTS.

A. Lenthay & Co., Perkins St. Nurseries, Roslindale, Mass.
For page see List of Advertisers.

HARDY FERNS.

H. J. Smith, Hinsdale, Mass.
For page see List of Advertisers.

NEW STRAWBERRY, THE HIGHLAND.

M. Crawford Co., Cuyahoga Falls, O.
For page see List of Advertisers.

ORNAMENTAL TREES, EVERGREENS, HEDGE PLANTS, ROSES.

The Morris Nursery Co., Sales Office, 1 Madison Ave., New York.
For page see List of Advertisers.

PLANT AUCTION SALES.

Wm. Elliott & Sons, 291 Fulton St., New York.
For page see List of Advertisers.

RETAIL FLORIST.

M. A. Bowe, 124 Broadway, New York.
For page see List of Advertisers.

SEEDS.

Wooler & Don, 114 Chambers St., New York.
For page see List of Advertisers.

SEEDS FOR GARDENERS, TRUCKERS, PLANT GROWERS.

Francis Brill, Hempstead, L. I., N. Y.
For page see List of Advertisers.

SHAMROCKS.

Leonard Cousins, Jr., Concord Junction, Mass.
For page see List of Advertisers.

SWEET PEAS.

Watkins & Simpson, 12 Tavistock St., London, Eng.
For page see List of Advertisers.

TRAGET BRAND INSECTICIDES.

Wm. Elliott & Sons, 291 Fulton St., New York.
For page see List of Advertisers.

WANTED,

To buy, to lease with the right to buy, or to lease, several Green-houses with ground where retailing and landscaping is possible. Address L. L., care of HORTICULTURE.

WANTS, FOR SALE, ETC.

Advertisements in this column one cent a word. Initials count as words. Cash with order. All correspondence addressed "care HORTICULTURE" should be sent to 11 Hamilton Place, Boston.

HELP WANTED

WANTED—SALESMAN

To Handle Good Side Line On Commission

One who calls on Florists, Seed Houses, Nurseries, Cemetery Superintendents, Monument Dealers, etc.

The Kramer Bros. Foundry Co.
DAYTON, OHIO

HORTICULTURE needs a wide-awake representative in every town in the land. Good commission paid on advertising and subscriptions. If you are ambitious, write for terms.

SITUATIONS WANTED

GOOD MEN

When you need good men, skilled or unskilled, Write:

THOS. H. BAMBRICK

34 South 7th Street Philadelphia

Help of all kinds, including that for Florists, Nurserymen, Seedsmen and the Horticultural trade generally.

WANTED—Situation as gardener or manager, private place preferred; graduate of Massachusetts Agricultural College; good experience since; best of references. Address D. C., care HORTICULTURE.

SITUATION WANTED by gardener; single; private or commercial; 20 years' experience in all branches. References. Address, Gardener, care HORTICULTURE.

SITUATION WANTED in general greenhouse work; single, age 35, five years' experience, commercial. Address W. W., care HORTICULTURE.

FOR SALE

HOT-BED MATS

STRAW, 6x6, little used 75c to \$1.00
G. H. FROST, West Newton, Mass.

FOR SALE OR TO LET—15 acres of land, nearly all under cultivation; 20,000 sq. ft. glass, house well stocked with carnations, chrysanthemums, etc.; 8-room dwelling house, steam heated; large barn; in a city of 14,000 population, 10 miles from Boston; excellent transportation facilities. Good retail trade now established. Terms will be made satisfactory. Possession given April 1 or sooner if desired. Address A. G., care HORTICULTURE.

MISCELLANEOUS WANTS

WANTED To rent, with privilege to buy about 10,000 feet of glass, within 20 miles of New York. E. Romain, 1243 Brooklyn Avenue, Brooklyn, N. Y.

Is Your Name In The Above List? If Not, Why Not?

SHAMROCKS

The popular miniature plants in
1 inch pots per 100 \$4.00
2 inch pots " " 4.00

The "ALL GREEN" Variety.

Green Carnation Coloring

FOR ST. PATRICK'S DAY.
Put up in sealed cans—pts. 65c; qts. \$1

Green 6-ply Florists' Twine

Matching exactly in Color the
FLORISTS' GREEN FOLDING
BOXES. Constantly on hand.
On 16-oz. tubes only; 60c per lb.

N. F. McCarthy & Co.

84 Hawley St., Boston, Mass.

Martial Bremond

WHOLESALE GROWER OF FRENCH BULBS

— OLLIOULES, FRANCE —

A superior quality supplied at
market prices. Shipments made
direct. Cases marked to order.

— Sole Agents —

RALPH M. WARD & COMPANY

12 West Broadway - - NEW YORK

NEWS NOTES.

The stock of the Mt. Hope Floral Co., Bangor, Me., was disposed of at auction on February 29.

The contract for constructing a new greenhouse in Schiller Park, Columbus, O., was awarded on February 24 to Borrer & Feustil, their bid being \$4,925.

Among the appropriations made by the House of Representatives of Rhode Island recently was \$1,000 for the Woonsocket Agricultural and Horticultural Society.

Breitenstein & Flemm, florists, Pittsburg, Pa., have taken a ten years' lease of the building 638 Liberty avenue, which is to be thoroughly remodelled for their occupancy.

Chas. A. Kibbe, the Lady Roosevelt Aster man, writes us from Elmhurst, Ill., that orders for seeds of this fine introduction are coming in from points as distant as Alameda County, Cal., where the need of a reliable aster of modern type is seriously felt.

The second annual banquet of the Albany Florists' Club (N. Y.), was held at Hotel Belvidere February 25. Fred Goldring was toastmaster, and in response to toasts John A. Howe, Jr., rendered several recitations, James Karins from the Pacific Coast spoke, F. A. Danker and Wm. C. King were heard from.

AN ORCHID SOCIETY PROPOSED.

A meeting is to be called for next week in New York for the purpose of discussing the desirability of organizing a society devoted exclusively to the interests of orchid culture. It is proposed to hold periodical exhibitions under the auspices of the society in various centres. Both amateur and professional orchid fanciers are interested in the movement.

USEFUL BOOKS.

We can supply the following books, postpaid, at the prices listed:—

The Chrysanthemum. Herrington. Price, 50 cts.

How to Make Money Growing Violets. Saitford. Price, 25 cts.

Daffodils-Narcissus and How to Grow Them. A. M. Kirby. Price, \$1.10.

Commercial Violet Culture. Dr. B. T. Galloway. Price, \$1.50.

Water Gardening. Peter Bisset. Price, \$2.50.

Lawns and How to Make Them. Leonard Barron. Price, \$1.10.

Roses and How to Grow Them. By Many Experts. Price, \$1.10.

The New Cyclopaedia of American Horticulture. L. H. Bailey. Four volumes; \$20.00.

How to Make School Gardens. H. D. Hemenway. Price, \$1.10.

How to Make A Fruit Garden. S. W. Fletcher. Price, \$2.20.

How to Plan the Home Grounds. S. Parsons, Jr. Price, \$1.10.

Soils: How to Handle and Improve Them. S. W. Fletcher. Price, \$2.20.

The Art of Landscape Gardening, by H. Repton. Price \$3.20, postpaid.

Water Lilies and How to Grow Them. Henri Huss and H. S. Conard. Price, \$1.21.

A Plea for Hardy Plants. J. Wilkinson Elliot. Price, \$1.76.

How to Make a Flower Garden. Price, \$1.76. By Various Experts.

Ferns and How to Grow Them. G. A. Woolson. Price, \$1.21.

Chrysanthemum Manual. Smlth. Price, 40 cts.

J. W. Bagge has taken a position as superintendent of Mrs. Franks' estate, Burlingame, Cal.

Every issue of HORTICULTURE contains some splendid articles.

A. F. J. BAUR

Indianapolis, Ind., Feb. 11, 1908

BOSTON FLORIST LETTER CO.

Manufacturers of FLORISTS' LETTERS

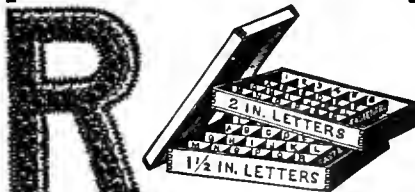

This wooden box nicely stained and varnished, 18x30x12, made in two sections, one for each size letter, given away with first order of 500 letters

Block Letters, 1 1/2 or 2 inch size per 100, \$2.
Script Letters, 3. Fastener with each letter or word. Used by leading florists everywhere and for sale by all wholesale florists and supply dealers

N. F. McCARTHY, Manager
66 Pearl Street, BOSTON, MASS.

In ordering goods please add "I saw it in HORTICULTURE."

The "Japana" Cut Flower Holder

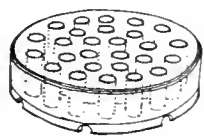

A handy article for florists. Sells to the trade on sight Made of glass in three sizes. The "Anglals" Table Decoration, something entirely new, long needed. The florist and housewife will appreciate this article, as it simplifies the art of table decorating

Ask for catalog.

M. V. CARNSEY, Dept. M,
130 Waiola Ave., La Grange, Ill.

KORAL SCRIPT LETTERS AND EMBLEMS

ONCE USED ALWAYS USED
Forsale by all first class supply houses. Made by
KORAL MFG. CO.
26 Hawley St., Boston

BOXWOOD

Finest quality, \$17.50 per Cwt.

GALAX

Green, \$1.00 per 1000; \$7.50 per 10,000.
Bronze, \$1.00 per 1000; \$7.50 per 10,000.

Hardy Ferns, Best Grade. \$1.50 a 1000

LAUREL, MOSS, PRINCESS PINE, FESTOONING.

N. F. McCARTHY & CO., Telephone
8973-8974 Main 84 HAWLEY ST., BOSTON

Largest Dealers in Florists' Supplies in New England

"SCALECIDE"

HAS MADE SPRAYING EASY THEN WHY NEGLECT YOUR TREES?

The N. Y. Herald, November 17, '07, says: "The chances are about a hundred to one that you have the San Jose Scale on your place and do not know it," and advises the use of "SCALECIDE." This is good advice. "SCALECIDE" has been tested and tried, and found thoroughly effective. The same yesterday, to-day, and all the time. One gallon makes 15 to 20, ready to use, by simply adding water.

Prices: 1 gal., \$1.00; 5 gal., \$3.25; 10 gal., 6.00; 50 gal. hbl., \$25.00, F. O. B. our factory. Order to-day. Write for booklet Waad free sample.

**B. G. PRATT CO., Mfg. Chemists,
11 Broadway, New York City.**



RHODES DOUBLE CUT PRUNING SHEAR

Pat'd June 2, 1903.

**RHODES MFG. CO.,
GRAND RAPIDS, MICH.**

THE only pruner made that cuts from both sides of the limb and does not bruise the bark. Made in all styles and sizes. We pay Express charges on all orders. Write for circular and prices.



GREENHOUSES BUILDING OR CONTEMPLATED.

- Corona, Cal.—H. Strauss, one house.
- Deerfield, N. H.—C. R. Brown, one house.
- Johnson, R. I.—Nelson Taft, one house.
- Roslyn, N. Y.—W. F. Sheehan, range of houses.
- Park Ridge, Ill.—Benjamin Gruppe, house, 32x200.
- San Francisco, Cal.—H. Plath, fern house, 26x235.
- Wareham, Mass.—Everett Benson, one house.
- New Bedford, Mass.—R. H. Woodhouse, one house.
- Grosse Pointe, Mich.—F. Pantke, violet house, 10x200.
- Rock Island, Ill.—H. Gaethje, three houses, each 29x119.
- New Albany, Ind.—A. Rasmussen, carnation house, 12x300; propagating house, 10x150.

LIST OF PATENTS.

Issued February 18, 1908.

- 879,332. Riding Attachment for Harrows. Chas. S. Sharp, Auburn, N. Y., assignor to International Harvester Company, a Corporation of New Jersey.
- 879,339. Seed Planter. Henry H. Walters, Racine, Wis.
- 879,429. Cultivator. Samuel H. Young, Phillipsburg, Kans.
- 879,487. Plow-Share. Charles W. McWane, Lynchburg, Va., assignor to Lynchburg Foundry Co., Lynchburg, Va., a Corporation of Virginia.
- 879,613. Transplanting Basket. Chas. Edwards, Dallas, Texas.
- 879,717. Seed Corn Magnifier. George Anderson, Wakefield, Nebr.
- 879,831. Disk Drill. Albert Armitage, Fairport, and William P. Thistlethwaite, Macedon, N. Y., assignors to Ontario Drill Co., Despatch, N. Y., a Corporation of New York.
- 879,838. Insect Destroyer. Joseph S. Peek, Kerrville, Texas, assignor of one-half to James H. Holliman, Kerrville, Texas.

The Best Bug Killer and Bloom Saver



For PROOF Write to

**P. R. Palethorpe Co.
OWENSBORO, KY.**



DREER'S SHEEP MANURE
(WIZARD BRAND)
1000 lbs., \$1.75; 500 lbs., \$3.00;
SPECIALTIES 1000 lbs., \$15.00; Ton, 2000 lbs., \$30.00

HENRY A. DREER, 714 Chestnut St., Phila., Pa.

Cattle Manure In Bags

Shredded or Pulverized



Best and safest manure for florists and greenhouse use, absolutely pure, no waste, no danger. Write for circulars and prices.

The Pulverized Manure Co.,
31 Union Stock Yards, Chicago

The FLORISTS' HAIL ASSOCIATION OF AMERICA, insurer of 28,000,000 sq. ft. of glass. For particulars address **John C. Esler, Sec'y, Saddle River, N. J.**

FIRE RECORD.

A large greenhouse belonging to Edwin Tibbits, of Vassar, Mich., which had recently been completed and stocked with plants, was badly damaged by fire on February 16. The fire extended to his dwelling house and the loss on all was about \$3000; insurance, \$1100.

JOHN A. PAYNE GREENHOUSE

Designer & Builder
260-274 Culver Ave.
JERSEY CITY, N. J.

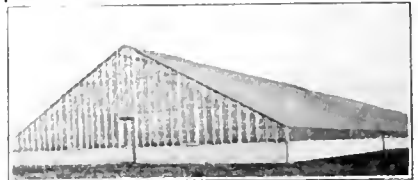

IRON FRAME SEMI-IRON FRAME TRUSS ROOF WOOD FRAME

Material Only or Erected

Everything for the Greenhouse

SECOND HAND PIPE & BOILER TUBES

Of all sizes, in good condition, suitable for steam purpose, coupled and threaded, for sale at low rates.

5000 feet 1 inch pipe, 3c. per ft.; 5000 feet 1 1/4 inch pipe, 4c. per ft.; 3000 feet 1 1/2 inch pipe, 5c. per ft.; 2000 feet 2 inch pipe, 6 1/2c. per ft.

EAGLE METAL & SUPPLY CO.,
Johnson and Union Aves., BROOKLYN, N. Y.

STANDARD FLOWER POTS

Packed in small crates, easy to handle.

Price per crate		Price per crate	
1500 2 1/2 in. pots in crate	\$4.88	120 7 in. pots in crate	\$4.20
1500 2 1/4 " " "	5.25	60 8 " " "	3.00
1500 2 1/2 " " "	6.00	HAND MADE	
1000 3 " " "	5.00	48 9 in. pots in crate	\$3.60
800 3 1/2 " " "	5.80	48 10 " " "	4.80
500 4 " " "	4.50	24 11 " " "	3.60
320 5 " " "	4.51	24 12 " " "	4.80
144 6 " " "	3.16	6 16 " " "	4.50

Seed pans, same price as pots. Send for price list of Cylinders for Cut flowers, Hanging Baskets, Lawn Vases, etc. Ten percent. off for cash with order. Address **Hilfinger Bros., Pottery, Fort Edward, N. Y.** August Holker & Sons, Agts., 81 Barclay St., N. Y. City.

Standard Flower . . . POTS

If your greenhouses are within 500 miles of the Capitol, write us, we can save you money

W. H. ERNEST,

28th and M Street WASHINGTON D. C.

BOSTON PLATE & WINDOW GLASS CO.

GREENHOUSE GLASS

German and American

261 to 287 A St., BOSTON 20-22 Canal St.

WILLIAM H. LUTTON

HORTICULTURAL ARCHITECT AND BUILDER

WEST SIDE AVENUE STATION (C. R. R. OF N. J.)
JERSEY CITY, N. J.

Have not been established 50 years, but long enough to convince the wide awake Florist and Gardener that it is to his interest to place his work in thoroughly practical hands.

(150,000 sq. ft. glass erected in 1907 will substantiate this claim)

And why not? My material is the best that can be secured. My iron frame construction has every modern feature that years of practical experience can embody.

AND THEN THERE IS THE COST TO BE CONSIDERED.

Why not let us take up this important question now?

GREENHOUSE GLASS

Cheaper Now Than For Years

We are taking contracts for next Spring delivery.

WRITE FOR OUR PRICES

STANDARD PLATE GLASS COMPANY

25-30 Sudbury St. 61-63 Portland St.
 BOSTON, MASS.

CYPRESS SASH BARS
 82 feet or longer
HOT BED SASH
PECKY CYPRESS BENCH LUMBER

GREENHOUSES

ERECTED AND EQUIPPED COMPLETE IF DESIRED

Write for Circular "D" and Prices

The A. T. STEARNS LUMBER CO.
 NEPONSET, BOSTON, MASS.

S. JACOBS & SONS
 Manufacturers of GULF CYPRESS

GREENHOUSE MATERIAL
 HOT-BED-SASH & FRAMES

Jobbers in **Boilers-Pipe-Fittings** and

GLASS on which we can quote attractive prices. Disc on large quantities. We furnish everything for Greenhouse Building
1365-1379 Flushing Avenue
BROOKLYN, - NEW YORK

NOW IS THE RIGHT TIME TO FIGURE **MATERIAL** AND PLAN FOR THE BUILDINGS OF THIS YEAR

FOLEY'S QUALITY AND WORK THE BEST. PRICES RIGHT AND LOWEST. ESTIMATES WILL PROVE. TRY US.

Foley Ventilating Apparatus Unequaled

Will Ventilate any Size of House Easily. Send for Circular.

THE FOLEY MFG. CO. Western Ave. 25th & 26th Sts. **CHICAGO**

IRON PIPE

SECOND HAND

WROUGHT IRON PIPE, for Steam, Water, Gas or Oil, Fences or Posts. All Sizes. Price Low.

GEO. B. DOANE & SON
 18 Midway Street, BOSTON
 Telephone, Main 4419

ANCHOR GREENHOUSE HOSE

WEARS WELL.

PLANT BED CLOTH

Protects from Cold and Dampness.

MINERALIZED RUBBER CO.

18 Cliff Street New York

GREENHOUSE CONSTRUCTION LUMBER

John C. Moninger Co.
 117 E. Blackhawk St., CHICAGO

R. TONAWANDA, N. Y.



ISAAC CASSIDY

Summer Ave. & Erie R.R., Newark, N. J.

Write for Prices

GREENHOUSE MATERIAL
 CONSTRUCTION FITTINGS

Bench Fittings

Material Furnished and Erected

PATENTS

Trademarks and Copyrights

Send your business direct to Washington. Saves time and insures better service. Personal attention guaranteed. Twenty-five years' active service. SPECIALTY: "Working on the Failures of Others."

SIGGERS & SIGGERS

PATENT LAWYERS

Box 9, National Union Building
 Washington, D. C.

Holds Glass Firmly FULL SIZE N. 2

See the Point

PEERLESS

Glassing Points are the best. No right or left. Box of 1,000 points 75 cts. postpaid.

HENRY A. DEER,
 714 Chestnut St., Phila., Pa.

In ordering goods please add, "I saw it in HORTICULTURE"



With the open mortise joint the water easily soaks in, and not only the side but every part of the joint decays.

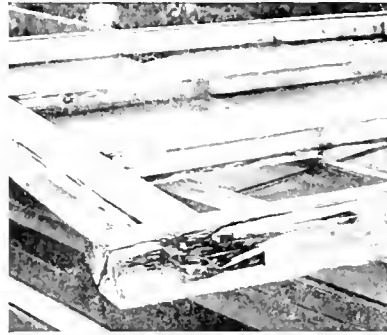

This is what happened to the side rail of an open mortise joint after the sash had been in use but nine years. Photo made the fifth of October, at Middle Village, L. I.



And here is an L & B sash, made L & B way, that has stood the racket for eighteen years, and is good for half as many more. Photos taken this year at the largest florist seedsman's place in the country.

EVERY USER OF SASH SEND

for our SASH THAT LAST CIRCULAR. It is not a lot of "hot air" about our sash, but a plain, common sense statement of the right and wrong way to make sash, and why the wrong way is wrong. It includes several tests, prices and freight allowance. Send for it.

WE MAKE EVERY PART OF A GREENHOUSE
BUT THE GLASS. WE SELL ANY PART

LORD & BURNHAM CO.

MAIN SALES OFFICE: NEW YORK
BRANCHES: BOSTON — PHILADELPHIA

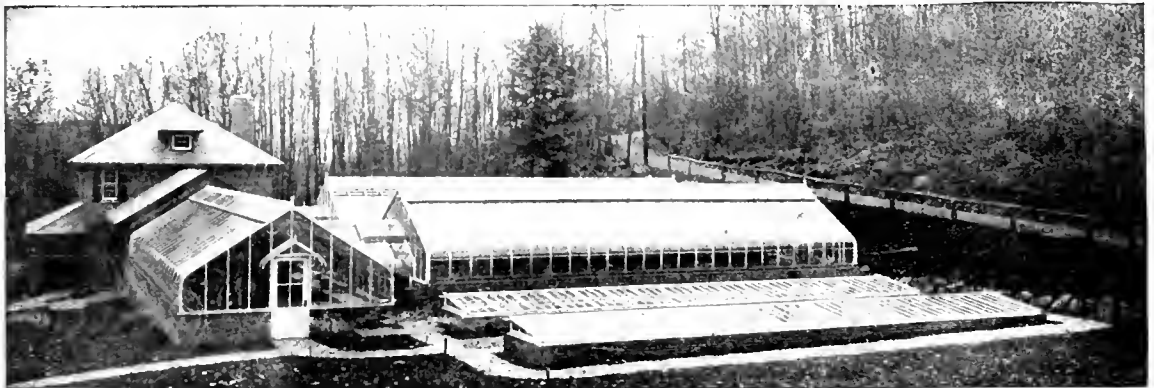

WHERE AVAILABLE SPACE COUNTS

Here is a range of U-Bar houses erected at Tuxedo Park. You can see that the available ground space is somewhat limited by the existing roads. In such a location, every bit of bench room must count to best possible advantage; each house be equally efficient. No other houses meet these demands like the U-Bar, because of its extreme lightness, giving to each house much more light than other constructions. Send for catalog, it shows you why.

U-BAR GREENHOUSES

PIERSON
DESIGNERS AND BUILDERS



U-BAR CO.
1 MADISON AVE., NEW YORK

HORTICULTURE

Vol. VII. MARCH 14, 1908 No. 11



PHALAENOPSIS APHRODITE.

Devoted to the
**FLORIST, PLANTSMAN,
LANDSCAPE GARDENER**
and
Kindred Interests

Published
EVERY SATURDAY
At 11 Hamilton Place,
BOSTON, MASS.
Subscription, \$1.00

CANNA BULBS

Fine plump, Northern Grown, and in fine condition. Not to be compared with southern grown stock, that are never thoroughly ripened and therefore are very slow to start growing.

	Doz.	100	1000		Doz.	100	1000
Allemania	\$0.35	\$2.50	\$22.50	Gladiator	\$0.40	\$3.00	\$27.00
Black Prince	.40	3.00	27.00	King Edward	.50	3.50	32.00
Black Warrior	.35	2.50	22.50	Louisiana	.55	4.00	35.00
Burbank	.30	2.25	20.00	Mad, Crozy	.40	3.00	27.00
Black Musafolia	.40	3.00	27.00	Mlie, Berat	.30	2.25	20.00
Charles Henderson	.35	2.50	22.50	Musafolia	.30	2.25	20.00
Director Roe'z	.35	2.50	22.50	Paul Marquant	.30	2.25	20.00
Flamingo	.30	2.25	20.00	Pres. McKinley	.35	2.60	22.50
Florence Vaughan	.35	2.50	22.50	Queen Charlotte	.35	2.50	22.50
Golden Star	.30	2.25	20.00	Robusta	.30	2.00	18.00
				Red Cross	.30	2.25	20.00

STUMPP & WALTER CO., 50 Barclay St., NEW YORK

PELARGONIUMS We have a fine lot of good strong plants in 3 inch pots at \$1.50 per dozen, \$6.00 per 100; such varieties as Purity, Gloria, Countess of Crew, Tommy Dodd, Duke of Cornwall, Lady Carrington and others.

GERANIUMS A splendid stock of fine plants from 2 inch pots, good standard sorts and new varieties at \$2.00 per 100 and up to \$1.00 each. We will send 1000 in 20 good varieties, our selection, for \$18.50. Our special descriptive Geranium Catalogue, describing over 250 varieties of Geraniums and Pelargoniums mailed free to the trade.

HARDY CHRYSANTHEMUMS Our collection of Hardy Chrysanthemums will compare favorably with any in the country and we have an immense stock ready for shipment. Small flowered or Button Varieties, \$2.00 per 100. Large Flowered or Aster Varieties, \$3.00 per 100. Descriptions will be found in our Wholesale List.

DAHLIA ROOTS We still have about 75 varieties we can offer in Cactus, Decorative Show and Pompon true to name at \$5.00 per 100 and up for Whole Field-grown clumps. One thousand, 50 each of 20 varieties. Our selection, for \$40.00, all good kinds; a splendid collection for planting or just the thing for Store Trade.

	Per 100		Per 100
Ivy Leaved Geraniums, 6 good kinds, \$25.00 per 1000	\$3.00	Hardy English Ivy, Extra Strong, \$15.00 per 1000	\$2.00
Hardy Chrysanthemums, 75 var.	2.00-3.00	Hollyhocks, Strong 3 in. pot plants, dbl. white, pink, red and yellow	3.00
Alyssum, Giant Double	2.00	Lobelia, Crystal Palace Gem	2.00
Cuphaea, Cigar Plant	2.00	Panicum, Variegated, Handsome basket plants	2.00
Coleus, Verschaffeltii, Golden Bedder and other kinds	2.00	Tradescantia, Dark Variegated	2.00
Swainsona, Alba	2.00	Verbena, Red, White, Purple and Pink	2.00
Fuchsias, Black Prince and Minnesota	2.00	Caladium, Esculentum, 1st size \$2.00 per 100; 2nd size	1.00
Lieutenant Muritz, White and Rose Phenomenal	2.50	Lavender, 2 1/2 in. pots strong	3.00
		Lantanas, 5 varieties	2.00

R. VINCENT JR. & SONS COMPANY, White Marsh, Md.

YOU WANT THEM NOW

Before the cream of the varieties is all sold. The finest stock of standard

HARDY PERENNIALS

in the country. Write and we'll quote tempting prices.

Red Oak Nurseries, Fiskeville, R. I.

AZALEAS for fall delivery, the best that are grown, also **PALMS** for spring or fall delivery, furnished by Belgium; orders for August Haerens, Somergem, booked now....

ADDRESS THE AMERICAN REPRESENTATIVE: **AUGUST ROLKER & SONS, 31 Barclay Street, or P. O. Box 752, New York**

Decorative Plants

Azaleas, Kentias, Rubbers, Arecas
Araucarias, Pandanus, Box Trees,
Euonymus, Crotons, and
Eurya latifolia.

Extra good value in

EASTER PLANTS

Order Ahead.

A Leuthy & Co.

Perkins Street Nurseries, Roslindale, Mass.

Established 40 Years
Rose Hill Nurseries
New and Rare Plants
NEW ROCHELLE, N. Y.

New York Office, Siebrecht Building, 425 Fifth Avenue

GODFREY ASCHMANN
Importer and Wholesale Grower
and Shipper

of Araucaria Excelsa, Compacta, Robusta and Glauca; Kentia Forsteriana and Belmoreana Azalea, Indica, etc. Cultivator of Boston, Scotchii, Barrowsii, Elegantisima and Whitmanii Ferns. Ferns for dishes, Cocos, etc. Write for prices.

1012 Ontario St., Philadelphia

GLADIOLI

I can satisfactorily supply your wants for Gladioli for forcing or outdoor planting. Mixtures, color sections or named varieties of exceptional beauty.

Write for Prices

ARTHUR COWEE

Gladiolus Specialist

Meadowvale Farm, BERLIN, N. Y.

COLEUS

Verschaffeltii, Golden Queen, Fire Brand, Lord Palmerston, Queen Victoria, Beckwith's Gem. Prices of Rooted Cuttings by express, 60c. per 100; \$5 per 1000. Less than 250 of a variety will be charged at the 100 rate.

Golden Bedder, Hero, Tessey, Pearl of Orange. 75c. per 100; \$6 per 1000. Less than 250 of a variety will be charged at the 100 rate.

Fancy Varieties. A very fine assortment of twelve kinds not listed above. 75c. per 100; \$6 per 1000. 250, in assortment, our selection, at the 1000 rate.

MISCELLANEOUS PLANTS

AGERATUM, Stella Gurney, Princess Pauline, SALVIA Splendens, Bonfire, HELIOTROPE. Rooted cuttings, 75c. per 100; \$6 per 1000. ALTERNANTHERA, Red and Yellow. Rooted cuttings, 50c. per 100; \$5 per 1000.

CARNATIONS

Rooted Cuttings	100	1000
Winsor	\$6.00	\$50.00
White Perfection	2.50	20.00
Rose Pink Enchantress	3.50	30.00
Enchantress	2.50	20.00
Queen Louise	2.50	20.00

From 2 1/4 inch pots, add \$1.00 per 100.

ASPARAGUS PLUMOSUS MANUS SEEDLINGS
From flats, \$1.00 per 1000.

CHRYSANTHEMUMS

Standard varieties, ready for shipment. Rooted cuttings, \$2 per 100; \$15 per 1000. Send for list.

A. N. PIERSON, CROMWELL, CONN.

GLADIOLUS BULBS

100,000, from 1 1/4 inches up @ \$1.00 per 1000
100,000, 3/4 to 1 1/4 inches @ \$2.00 per 1000
Cash with order. Description given on request.
Nice block of California Privet, \$10.00 per 1000 and up, as to quality. Write for particulars.
Nice lot of American Chestnut Trees at a bargain. Thirty-five large Sugar trees, most of them sample trees.

I. & J. L. LEONARD, IONA, N. J.

HYACINTHS, TULIPS, NARCISSI AND OTHER BULBS

ROMAN HYACINTHS and the true PAPER WHITE GRANDIFLORA

Ask for our Wholesale Trade List at Hillegom

K. VELTHUYS, Hillegom, Holland
Rep. by FELIX BOSCH, 260 Clarendon St., Boston.

CANNAS

Send for our List and Prices
The CONARD & JONES CO.
WEST GROVE, PA.

In ordering goods please add, "I saw it in HORTICULTURE."

ROBERT CRAIG CO.

ROSES, PALMS,

and Novelties in Decorative Plants
MARKET and 49th STREETS., PHILADELPHIA, PA.

CARNATION CUTTINGS

We are in unusually good position to supply exceptionally well-rooted, healthy stock. We have such a large quantity of flowering plants that we propagate only from heel cuttings from flowering shoots. Our cuttings are rooted in light, sunny, airy houses, and we are sure will satisfy the most critical buyer. A prominent carnation grower writes, "You seem to be the only firm in the business that knows how to pack stock and have it reach the buyer in good condition, and I have always found your cuttings cheaper than the same varieties from others at much lower figures." While our prices may not always be the cheapest, we certainly can give, quality considered, as good value as, if not better than, is obtainable anywhere.

WINSOR which we introduced last year has proved to be the finest novelty introduced in years. We think it is the most profitable variety grown today, considering its fine color, splendid keeping qualities, and productiveness. When properly grown, it leaves little to be desired, and almost every one succeeds with it.

WHITE ENCHANTRESS the best all-round white carnation, on account of its large size, long stem, earliness, and productiveness. Our White Enchantress, exhibited at the Carnation Convention at Washington, was the only White Enchantress exhibited that received an award.

Strong rooted cuttings, now ready for delivery, from sand \$6 per 100, \$50 per 1000; from soil, \$7.50 per 100, \$60 per 1000.

We offer also **Beacon** and **Red Chief**, from sand, \$6 per 100, \$50 per 1000; from soil, \$7.50 per 100, \$60 per 1000. Also **Victory**, **Melody** and **White Perfection**, from sand, \$4 per 100, \$35 per 1000; from soil, \$6 per 100, \$45 per 1000. **Variiegated Lawson**, **White Lawson** and **Red Lawson**, from sand, \$3 per 100, \$25 per 1000; from soil, \$4 per 100, \$35 per 1000. We can supply, also, **Winona** and **Afterglow** at \$12 per 100, \$100 per 1000.

Buyers will find transplanted stock offered from soil well worth the difference in price

F. R. PIERSON CO., - - Tarrytown-on-Hudson, NEW YORK

CHRYSANTHEMUMS

Novelties for 1908, in 2½ inch Pots, Ready for Immediate Shipment

MRS. NORMAN DAVIS. Pure white, an improved Mme. Carnot. Best exhibition white out.
DOROTHY GOLDSMITH. Might be called a bronze F. S. Vallis, and easy doer. The finest bronze out.
KATIE PALGRAVE. A clear, waxy white, resembling Mrs. A. T. Miller, but fuller, and two weeks later.
MRS. SOUTHGATE. As large as F. S. Vallis, but a brighter yellow.

O. H. BROOMHEAD. An immense, solid bloom, rich deep rose, with sturdy dwarf habit.
W. MEREDITH. Dark crimson, with gold reverse. An enlarged Edwio Molyneux. A reliable variety.
MARY DONELLAN. A splendid deep yellow.
JOSEPH STONEY. Best exhibition crimson.
HAROLD WELLS. Pure white. A monster.
MRS. J. C. NEIL. Soft canary yellow. An improved Cheltoni.

50c each, \$5.00 per doz., \$35.00 per 100

Also a Large Stock of the Leading Chrysanthemums on Hand. Varieties and Prices on Application.

The New Double Flowering Blue Lobelia **KATHLEEN MALLARD** Ready for Immediate Shipment. 25c each, \$2 50 per doz.

Scott Bros., ELMSFORD NURSERIES, Elmsford, N. Y.
 TELEPHONE 474 TARRYTOWN

Single Chrysanthemums ARE THE CRAZE

for the time being.

Are you in line to meet the demand?

I have now ready

KATIE COVELL, ROB ROY, HELEN TOTTY, HAROLD BISHOP, MRS. UNTERMEYER, ANNA SPANGLE,

and others, at

\$2.00 per doz., \$15.00 per 100.

I also carry a full line of novelties and standard varieties of

Chrysanthemums, Carnations and Roses

CHAS. H. TOTTY, MADISON, N. J.

New Violet BOSTON

In introducing this new variety to the trade I wish to state that I have been growing it in quantity for the past two years and do not hesitate to state that it is entirely distinct, a strong grower, a free bloomer, and the finest single violet in cultivation. Ready for distribution in April and May. Orders booked now. \$2 per 12; \$12 per 100; \$100 per 1000. 500 at 1000 rate.

WILLIAM SIM, CLIFTONDALE, MASS.

CARNATIONS ROOTED CUTTINGS

Winona, color, true clear pink, comes nearest to Fiancee but a different type flower. Growth on order of Scott but vastly improved in every respect. Early flowers in quantity and on long stems. Does not burst its calyx. Fine, shapely, active growth. In color and productiveness it is without an equal. Orders booked now and filled in strict rotation. \$12 per 100, \$100 per 1000.
White Perfection, pure white. We have a large stock. \$3 per 100, \$25 per 1000.

F. DORNER & SONS CO.
 LA FAYETTE, IND.

DAHLIAS. Now is the time to place your order for bulbs which will insure you getting named varieties in any quantity; prompt delivery.

DAVID HERBERT & SON,
 Successors to L. K. Peacock, Inc.
 ATCO, N. J.

100,000 DAHLIAS

Premium Stock, guaranteed true to name.
500,000 large Flowering Gladioli, hundreds of colors and variations mixed. Wholesale prices on application. Order now for spring delivery. Catalogue free.

J. L. MOORE, Northboro, Mass.

LLOYD IS THE REAL THING The Carnation for every one to grow

LLOYD is a commercial white, with a fancy flower

The only ever-blooming, large-flowering white in existence

Will take the place of all other whites now in commerce. Every New Bedford grower has bought stock. Come and investigate.

**A KEEPER
 A SHIPPER
 A BLOOMER**

It will bring the shekels when all others fail

\$2 pr 12. \$12 pr 100. \$100 pr 1000

Unrooted Cuttings
 \$6 per 100. \$50 per 1000.

H. A. JAHN
 NEW BEDFORD, - - MASS.

Carnation Cuttings

Both standard varieties and novelties. Stock guaranteed to be first-class. Address,

S. S. SHIDELSKY

1741 North 18th Street. Philadelphia

ROOTED CARNATION CUTTINGS

Only the Best Varieties

CHICAGO CARNATION CO., JOLIET, ILL.

JOHN E. HAINES Bethlehem, Pa.

is the place to order rooted-cuttings of the following varieties for 1908.

John E. Haines, fed Imperial variegated } Per 100 Per 1000
 Pink Imperial, Pink Enchantress, Light Pink } \$6.00 \$50.00
 Place your orders early for Jan. delivery.

PRICES QUOTED IN THESE COLUMNS ARE FOR DEALERS ONLY When Writing to Advertisers Please Mention Horticultur

300,000 CALIFORNIA PRIVET

1-year-old, 18-24 inches, 2-4 branches.	Per 1000
\$145.00 per 10,000; \$400.00 per 50,000	\$ 15.00
2-year-old, 2-3 ft., 5, 8 and 10 branches.	Per 100
35.00	
3-year old, standard, 5-6 ft., heads 2-2 1/2-3 1/2 ft. diameter	75.00
6-year-old, standard, 4-5 ft., heads 2-2 1/2-ft. diam.	50.00
2-year-old, standard, 4-5 ft., heads 18-24-in diam.	40.00
6-year-old, pyramidal, well sheared, 4-5 ft. high, 3-4 ft. diameter	75.00
6-year-old, 3 1/2 ft. high, pyramidal, 2 1/2-3 ft. diam.	50.00
2-year-old, 2 1/2-3 ft. high, pyramidal, 18-24-in. diameter	40.00
Elms, Am., fine trees, 11-12 ft. high, 1 1/2-2-in. cal.	40.00
Elms, Am., fine trees, 9-11 ft. high, 1 1/2-1 3/4-in. cal.	30.00
European Linden, 12-15 ft. high, 2 1/2-in. cal.	60.00
Althaea, double white with maroon center, 5-6 ft. high	15.00
Althaea, double white with maroon center, 4-5 ft. high	12.00
Althaea, double white with maroon center, 3-4 ft. high	10.00
Spiraea Billardii, 4-ft. high	6.00
Forsythia Viridissima, 3-4 ft. high	10.00
Lilac Rubra, Dr. Marley, 3-4 ft. high	10.00
Deutzia Crenata, 4-5 ft. high	11.00
Deutzia Gracilis, 4-year-old plants	8.00
Yucca Filamentosa, blooming plants	35.00

I will have a large collection of bedding plants for Spring delivery out of 25 greenhouses, such as Roses, Geraniums, Oleus, Heliotrope, Salvia Bonfire, or Scarlet Sage (which is the best bedding plant today), Lantanas, Verbenas, Begonias, Vinca Rosea, Alternantheras, red, yellow and pink; all kinds vase and hanging basket plants.

Send me your wants and I will give you price.

Carlman Ribsam

Office, 31 Wall St., TRENTON, N. J.
Greenhouses, East State St.
Nursery, Hamilton Ave.

BUY IN SEASON

Seedlings and Rooted Cuttings, extra fine, well rooted; three grades, just right for lining out: *Magnolia Glauca* (Sweet Bay), *Ampelopsis robusta purpurea* (New), *Ibota Privet* (Jap.), *Berberis Thunbergia* (Jap.), *Berberis Vulgaris* (Native) *Arborvitae American* and *Siberian*, Spruce, White Pine and Hemlock.

It will pay you to get our prices NOW

PIERCE NURSERY
BEVERLY FARMS, MASS.

The MORRIS NURSERY CO.
West Chester, PA.
NURSERIES ESTABLISHED 1849

SPECIALTIES for SPRING 1908

Norway Maple, 2 1/2 in. dia. and 2 1/2-3 in. dia.
Carolina Poplars, 10-12 ft., 1 1/2-2 in.
Cal. Privet Hedge Plants 2 yrs. old 2-3 ft. and 3 and 4 yrs. old 3-5 ft. Dwarf Box, 3-6 in.
Rhododendron Hybrids, 18-24 in. and 2-3 ft. choice hardy varieties Rhododendron Maximum, 2-8 ft., fine plants in car lots.
Kalmia Latifolia 1-4 ft., fine plants in car lots.
Blue Spruce, Koster's, 3-5 ft.
Hybrid Roses choice varieties.

Catalogue mailed upon request. Address all communications to

The MORRIS NURSERY CO
Sales office, 1 MADISON AVE., NEW YORK

AMERICAN NURSERY CO., COMBIN-
ING
FRED'K W. KELSEY, New York City
F. & P NURSERIES, Springfield, N. J.
BLOODGOOD NURSERIES, Flushing, L.I.
N. J. & L. I. N. RSERIES

We can supply you every need. Write for prices
Sales Department
150 BROADWAY, - NEW YORK

NEW My Maryland ROSE

"My Maryland" has more good commercial points than any other Rose. Price, 2 1-2 inch pots, \$25.00 per hundred; \$200.00 per 1000; \$5.00 per dozen.

JOHN COOK, 318 N. Charles St., Baltimore, Md.

TAUSENDSCHON

or in English *Thousand Beauties*, is the sensational new Climbing Rose of the year. Every florist should have it. It is not excelled for forcing purposes and for general planting by any Climbing Rose now known, **not even bearing Crimson Rambler**. This is the coming forcing Rose. Get your stock early. Illustrated in ten colors and gold in our Catalogue for 1908, the **Leading Rose Catalogue of America**. Every Rose worth having is described in it. Copy free for the asking.

Strong plants of Tausendschon from 3-inch pots, 10 for \$1.50; \$12.00 per 100; \$100.00 per 1000.

THE DINGEE & CONARD CO., WEST GROVE, PA.

JOHN WATERER & SONS, Ld.

American Nursery, Bagshot, England

Are Specialists in the

REALLY HARDY VARIETIES

of Rhododendron Hybrids and in Select Varieties of Hardy Border Plants.

HARDY NORTHERN GROWN NURSERY STOCK

At Reasonable Prices

FRUIT AND ORNAMENTAL TREES, SHRUBS, VINES, ROSES AND HERBACEOUS PERENNIALS IN GREAT VARIETY

Catalogue and Price List for the asking

BAY STATE NURSERIES, NORTH ABINGTON, MASS.

NEW NEW

RAMBLER ROSE "NEWPORT FAIRY"

To be disseminated Spring, 1908 Ask for Illustrated pamphlet and prices

JULIUS ROEHRS CO., Rutherford, N.J.

SPECIMEN EVERGREENS

Box Plants, Azaleas, Rhododendrons, Roses, Herbaceous Perennials

In fact everything in hardy stock for Garden, Lawn and Landscape Planting. General Catalogue and Trade Lists on application.

The NEW ENGLAND NURSERIES, Inc., Bedford, Mass.

LIVE FENCES

We believe we are the largest growers of Hedge plants in America—Privet our specialty—can supply any quantity both

Amor River and California, strong plants, at \$25.00 per M. Other varieties. Prices on application.

PETER'S NURSERY COMPANY, - Knoxville, Tenn.



PETER'S NURSERY COMPANY

Growers and Importers
of Hardy Plants

CABLE ADDRESS
"PENUCO"

KNOXVILLE TENN.

This letterhead can be equaled by our processes in any one of a multitude of different flowers. It is a tremendously attractive thing, and will be found worth all its costs.
Price, f. o. b. Harrisburg: First thousand, \$22; additional thousands, \$9 each.
Cash with the order.

THE McFARLAND PUBLICITY SERVICE
HARRISBURG, PA.

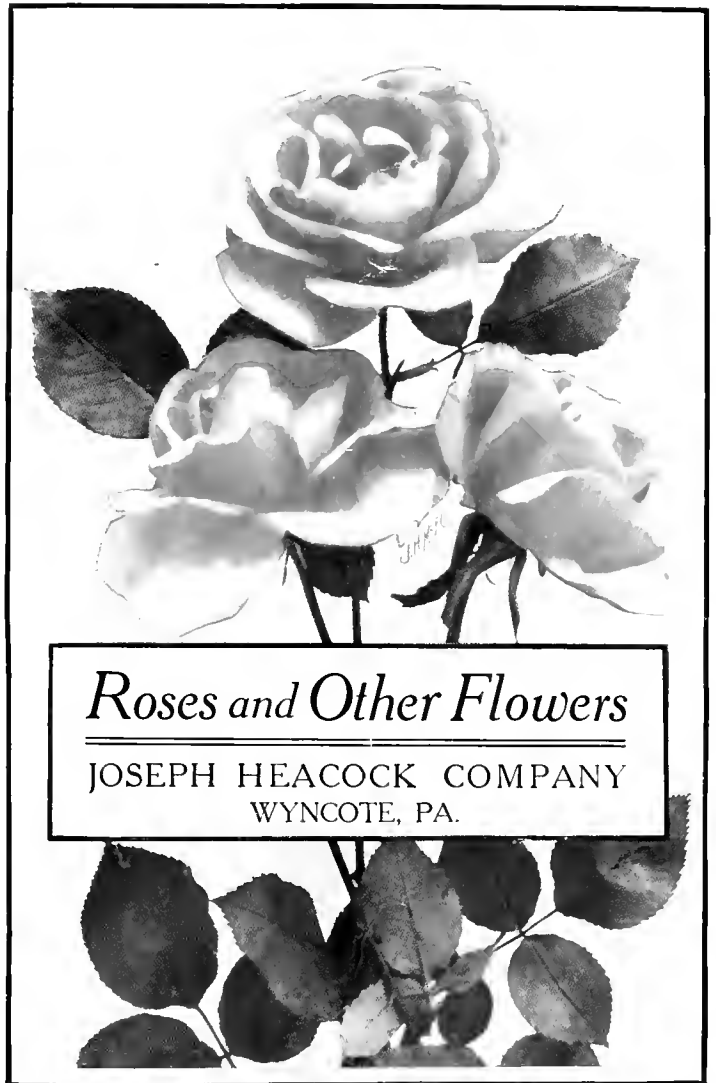

Roses and Other Flowers

JOSEPH HEACOCK COMPANY
WYNCOTE, PA.

This shows a cover of a very effective combination announcement and booklet. Top part of design may be used to splendid advantage for letterheads and postcards. Booklet contains eight pages and covers, other pages in one color only, printed on coated paper.

Price, f. o. b. Harrisburg: First thousand, \$60; additional thousands, \$15 each. Cash with the order.

Postcards in full colors are most effective in building trade for florists. They never escape the attention of the persons who receive them, and they are economical from a postage standpoint. In full colors on the back and one color on the front. If ordered with booklet—

Price, f. o. b. Harrisburg: First thousand, \$20; additional thousands, \$7.50 each. Cash with the order.

Letterheads, four colors, ordered with booklet and cards, \$22 for first thousand; \$9 for additional thousands. Cash with the order.

THE McFARLAND PUBLICITY SERVICE
HARRISBURG, PA.

BAKER BROS. CO., Inc.

TREES, PLANTS, SEEDS

Office and Seed Store, 508 Houston Street
Nursery and Greenhouses, Riverside

Such a letterhead as that shown here will give tone to the business of any florist—and sell itself. We have in stock Kase, Carnation and Axlott designs.

Price f. o. b. Harrisburg:
First thousand, \$7;
additional thousands
\$4 each. Cash with
the order



Fort Worth, Texas, _____ 190

The Picture's the Thing in Selling Flowers

TASTY printed matter, reproducing flowers from photographs, will create increased demand for the flowers themselves. If the photographic reproductions are made in the natural colors, by modern processes, an even greater increase in demand will result.

The live and up-to-date florist has stationery and printed matter in harmony with his stock. The McFarland organization makes such stationery for this kind of florists. The average job printer cannot begin to do it—he doesn't know how and hasn't the facilities.

The surpassing equipment and trained men at our service enable us to turn out work of a quality not obtainable elsewhere at any price—whether on a job of 500 postcards or 100,000 big catalogues.

Here are some specimens with prices. Over 10,000 photographs of other good subjects from which to choose are awaiting your call. Further information cheerfully supplied.

There's a form of printed matter your business needs. Ask The McFarland Publicity Service!

A couple of cents spent in getting every order the courtesy of acknowledgment will help you to secure additional business from home and regular customers. Postcards are the ideal form.

Price f. o. b. Harrisburg: First thousand, \$15; additional thousands, \$3.50 each. Cash with the order.

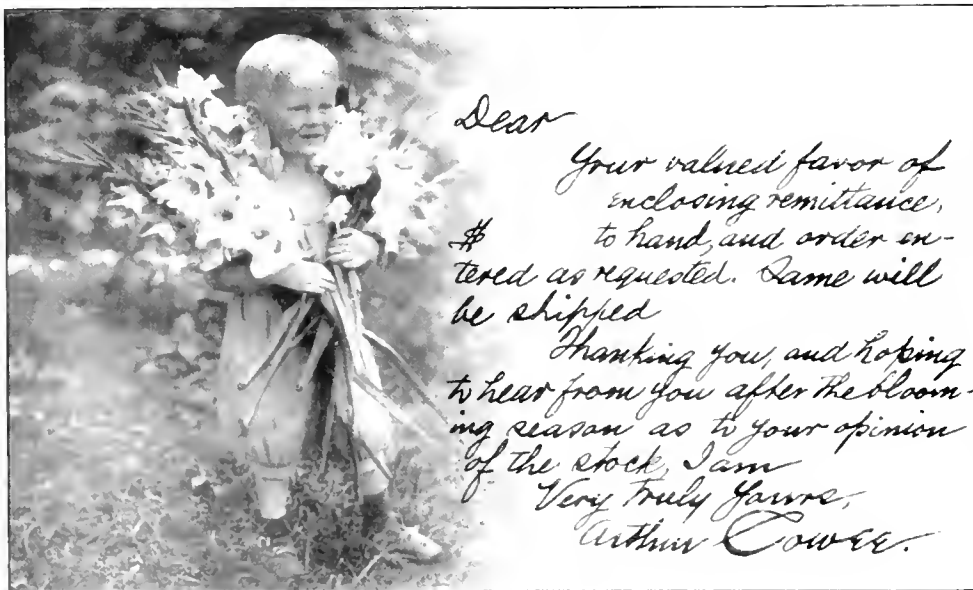

Dear
Your valued favor of
enclosing remittance,
to hand, and order entered
as requested. Same will
be shipped
Thanking you, and hoping
to hear from you after the bloom-
ing season as to your opinion
of the stock, I am
Very Truly Yours,
Arthur Cowee.

Postcards are a splendid medium through which to tell the people where you are and what you sell. All the back and one-half of the front of the card may be used for your message.

Price f. o. b. Harrisburg: First thousand, \$15; additional thousands, \$3.50 each. Cash with the order.

We have in stock large numbers of designs suitable for the illustration of postcards. When these are used with a picture instead of an engraved message, we can give better figures.

Price f. o. b. Harrisburg: First thousand, \$6.50; additional thousands, \$3 each. Cash with the order.

In our stock of over 10,000 original horticultural photographs, there are thousands which no florist in your section has used. These photos enable us to give endless variety to postcards.

Only a few examples of our designs can be shown hereon. Write us and we will submit others to suit your needs.

THE McFARLAND PUBLICITY SERVICE, HARRISBURG, PENNSYLVANIA

The Culture of Phalaenopsis

The frontispiece of this issue of Horticulture shows a house of Phalaenopsis Aphrodite as grown for Mrs. B. B. Tuttle of Naugatuck, Conn. There are about 250 plants of Aphrodite with an aggregate of over 1400 flowers. There were no Ph. Schilleriana in bloom at the time the picture was taken but a few good plants may be seen hanging from the roof. About 450 Phalaenopses are grown here, representing the following species: Aphrodite (often wrongly called amabilis), Schilleriana, amabilis or grandiflora, Luedemanniana, rosea, amethystina and the natural hybrid between Ph. Aphrodite and Schilleriana called Ph. leucorrhoda.

As the first four mentioned rank amongst the most beautiful and best paying cut flowers in the market it may interest some of Horticulture's readers to hear something of my method of growing this beautiful class of orchids.

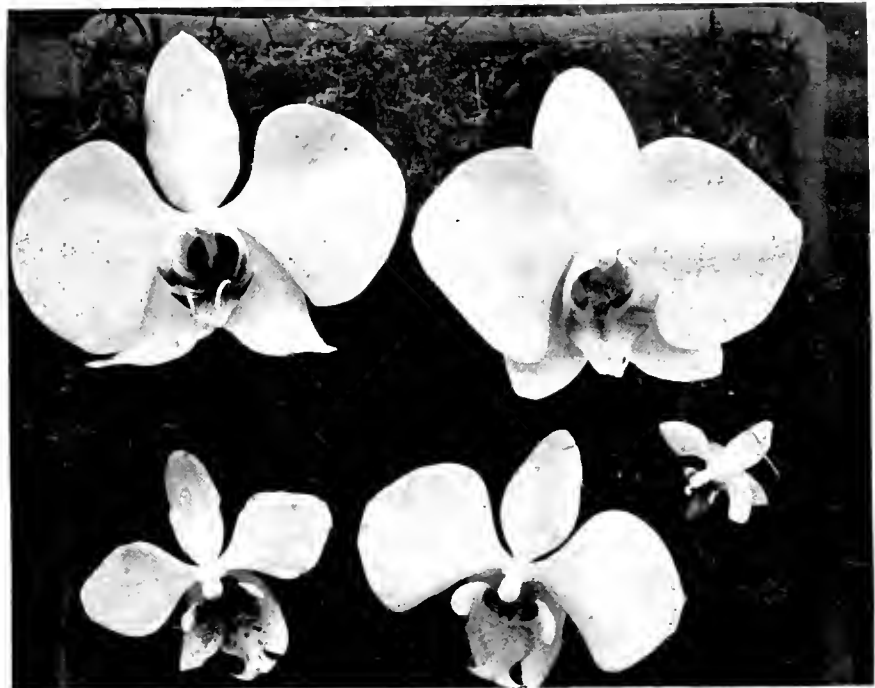

TYPES OF PHALAENOPSIS.

Amabilis,
or grandiflora
Stuartiana

Aphrodite
Schilleriana

Rosea

Phalaenopses, as a rule, are considered hard to grow and many otherwise good gardeners fight shy of them on that account. But after four years' experience with these plants coupled with careful observation and many experiments I have found that they can be grown almost as easy as cattleyas and indeed more easily than some varieties of that genus, providing a few simple rules are strictly adhered to. First of all keep the plants free of all insects, especially thrips; second, do not keep the plants nor the air of the house in which they are grown, saturated with moisture during winter; third, give plenty of fresh air whenever possible, and, last but not least, give them all the light possible without scorching the leaves.

Insects, especially thrips, must be kept down or the plants will not thrive. If the plants are grown suspended from the roof snails and cockroaches will not trouble them much but thrips, red spider, ants and water-bugs will find their way to them no matter where they are and a sharp lookout must therefore be kept.

Nicoticide is perhaps the best and cheapest compound for vaporizing but it must be used stronger than is recommended, else it will have but little effect on thrips and mealy bug. It will, unfortunately, injure tender ferns and therefore cannot be called a safe insecticide, but it is as safe as and kills more insects than any other insecticide I have tried. It will not injure the flowers of Phalaenopsis although a slight fumigating with tobacco stems will put them to sleep and will also

cause little eruptions or warts on the tender young leaves. The best and surest way to get rid of all these troublesome insects is to dip the plants bodily, leaves and all, into a tub containing some Nicoticide and enough fir tree oil to make the water look milky; to a butter tub full of water I use 2 oz. Nicoticide and 2 oz. fir tree oil; this solution will keep for several days and will not injure the plants.

This is the quickest and most certain way to find out if there are any thrips or other injurious insects hiding in the compost. Thrips will quickly rise to the surface and after a few seconds are put out of commission. Water-bugs will live in a solution of the strength recommended above for half an hour or more; however, they will soon come out of their hiding place and may then be killed by hand; the same holds true of snails and cockroaches. Red spider and mealy bug can easily be kept down by an occasional sponging and frequent syringing.

During the winter I try to keep the temperature of the house between 60 degrees and 65 degrees at night and 10 degrees higher through the day. But it often happens that the temperature drops to 54 degrees before morning and then again it may run up to 75 degrees some nights, which will do no harm, because the plants and atmosphere are kept on the dry side during winter with just a little air on the bottom at all times except in extreme cold weather.

The house is damped down once a day and the plants

syringed every bright morning, using a Gem nozzle for that purpose. Besides this damping down and syringing the plants are dipped once in a week or ten days in weak manure water.

In summer when fires are out and the house shaded less watering and damping will be required, otherwise that fatal disease called "rot" will make its appearance. A hot stuffy atmosphere is always sure to bring it on. I always keep a little air on top and bottom when there is no heat in the pipes and, should the weather be cold and damp for any length of time, a little fire is started up, even if it be in July or August. It does not matter how high the temperature goes in summer, day or night, so long as there is a good circulation of air.

During hot weather the plants require some shade, but let it be of some temporary kind. I use roller blinds made of cloth which are let down only when absolutely necessary to prevent the leaves from getting scorched. From the first week in September until the end of March the ground glass affords all the necessary shade.

Most of the plants are potted in osmunda fibre but some are in fibre and moss and some in all moss; it matters but little what they are potted in as long as the compost is open and other conditions are right. Osmunda fibre saves lots of work for, once a plant is potted in it, it will need no more attention outside of watering and keeping clean for the next three or five years, whereas moss will have to be renewed at least once a year. One other point in favor of osmunda fibre is that it dries out quickly and so lessens the danger of rotting the roots by keeping the compost wet too long.

By giving the plants lots of light and air in the fall they will be hardened off for the dull winter months and



PHALAENOPSIS SCHILLERIANA.

consequently will stand a lower temperature than is usually given them; the flower spikes will be of better substance and last much longer when cut or on the plant.

At this writing I still have some flowers of *Phalaenopsis Aphrodite* in good condition which opened up before Christmas. *Phalaenopsis Schilleriana* will not last over three or four weeks. Care should be taken not to let the same spike flower a second time or the plant will be ruined. It is best to cut the spikes as soon as the last bud has opened.

M. J. Cope

The Annual Rose Number

WILL BE ISSUED MARCH 21.

This Number will contain many features in connection with the Meeting and Exhibition of the American Rose Society and will be of Special Interest to Rose Growers.

Send Advertising Copy Now

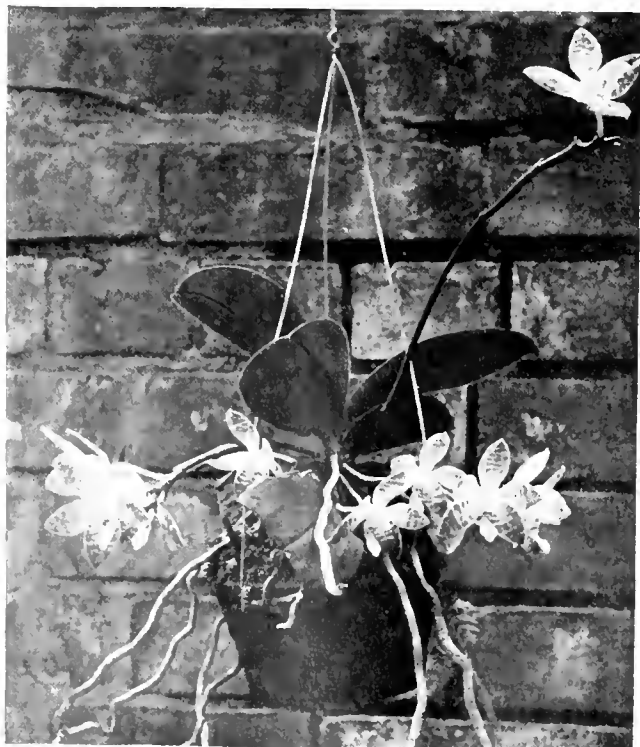

Points on Field and Indoor Culture of Carnations

In a short talk which I gave before the Boston Gardeners' and Florists' Club, on the evening of February 25th, I put all carnation varieties into classes, mentioning three different classes which appear to me. The first class with heavy foliage and leaves which incline to be curly. Winsor and Lawson are the two best examples of this class, for which there is nothing, in my opinion, but indoor culture.

The second class which I made includes the varieties which have thin foliage and a tendency to greater length between the joints. In naming varieties which would be typical of this class, I should mention Mrs. Patten, for the reason that as a general rule it conforms to these conditions of growth, i. e., thin foliage and long joints. As a variety to grow inside, it has not been the most successful, making a very small plant early in the year and not filling up until along in the winter. The best Mrs. Patten that I ever saw (and they were not grown by me) were field-grown plants. Aristocrat was grown to perfection this year in the West, the method of handling being field culture, and it has not been with us a successful variety to grow inside. The poor success which we had with Aristocrat we attribute partly to that cause, as it failed to make a large enough plant early in the season to stand the strain of blooming.

White Perfection also makes a very small plant with inside culture. While we have not grown it in the field, we believe it would make a better plant if benched early from the field. I mentioned Enchantress as one of the varieties which could be grown either inside or outside. Rose Pink, Enchantress, as well as White Enchantress would do equally well with the same treatment, the Enchantress family being typical of the third class.

Among the new varieties which we have in stock Miss Sarah Hill seems to be a promising candidate for indoor culture; a short, thick cutting, inclining to break from the bottom, or very low down. For a plant of this character, to secure the best results, I believe we should have indoor culture.

Splendor seems to be a very free grower, and one which will, if grown inside, make very thin shoots, and I believe that field culture will give a more substantial plant for benching.

Winona, of which we shall grow 1,000 plants, will, I think, be a good variety for either field culture or indoor culture, as the young plant is taking somewhat the nature of Enchantress with us, being a little more free and vigorous in growth than either Lawson or Winsor, and yet making plant enough to warrant its being substantial, without its being put into the field to force a bottom growth.

President Seelye has not made enough growth yet in pots so that we can determine its character.

I trust that this will explain to the satisfaction of your several correspondents all the points on which they have asked for fuller details.

Wallace R. Pearson

Fashion in Flowers

In the issue of March 7 HORTICULTURE presented to its readers an interesting illustrated article entitled "Flowering Apples."

The article being apropos, considering the vast amount of just such material being used at the present time, a few words regarding the various uses to which these marvelous blooms are put may be of concern to those interested in fair Flora's fashions, for fashion in flowers as in all things else, is assured.

It is safe to say that at any event of importance the pyrus, the prunus, the lilac and kindred dwarfed plants in blossom play an excellent part. Nor does the use of these gems of admiration stop at the decoration of homes, as bouquets and other forms of floral decoration claim an important part of their possibilities.

Much is being done in the way of bunches tied carelessly together and composed of these fruit blossoms.

The bouquets are frequently tied with gauze or other dainty ribbon to match or in pleasing contrast with the flowers. The whole effect is beautiful, and when the bunch is carried, as most of them are this season, the result is striking if not wonderful.

Imagine a debutante laden down with floral offerings, too many to carry at one time, and who with a desire to do honor to each donor, takes advantage of the opportunity to release herself from a burdensome duty and at the same time unwittingly sets an example which in time becomes a fashion, and you will behold the girl of the hour with bouquet tucked under her arm (the left arm, usually), the flowers pointing heavenward and the stems in the opposite direction, thus giving freedom to both hands. Such a bunch of flowers is generally known in New York as the "Arm bouquet," although it is no doubt sailing about under an alias.

But let not the gentle ones be deceived; the arm bouquet has not become a monopoly and never will, as the formal bouquet, like the brook, will keep on forever. The shower bridal bunch is yet in vogue, although the prayer book with a bookmark of lilies of the valley has been used more this season than formerly.

And history will repeat itself in fair Flora's affairs as in all others, for how many of the present generation are aware that the Camellia Japonica, the fashionable flower of today, is but the resurrected cast-off, but once recognized indispensable gem of the conservatory.

Wm. H. Long

HORTICULTURE

VOL. VII

MARCH 14, 1908

NO. 11

PUBLISHED WEEKLY BY
HORTICULTURE PUBLISHING CO.
 11 Hamilton Place, Boston, Mass.

Telephone, Oxford 292
 WM. J. STEWART, Editor and Manager

SUBSCRIPTION PRICE

One Year, in advance, \$1.00; To Foreign Countries, 2.00; To Canada, \$1 50

ADVERTISING RATES

Per Inch, 30 inches to page \$1.00.
 Discounts on Contracts for consecutive insertions, as follows:
 One month (4 times) 5 per cent.; three months (13 times) 10 per cent.;
 six months (26 times) 20 per cent.; one year (52 times) 30 per cent.
 Page and half page spaces, special rates on application.

Entered as second-class matter December 8, 1904, at the Post Office at Boston, Mass., under the Act of Congress of March 3, 1879.

CONTENTS

	Page
FRONTISPIECE—Phalaenopsis Aphrodite.	
THE CULTURE OF PHALAEOPSIS—M. J. Pope— Illustrated	325
POINTS ON FIELD AND INDOOR CULTURE OF CARNATIONS—Wallace R. Pierson.....	327
FASHION IN FLOWERS—Wm. H. Long.....	327
AFTER ADJOURNMENT	329
THE "JAPANESE SHAMROCK"—THE IRISH SHAM- ROCK—G. C. Watson	329
NEWS OF THE CLUBS AND SOCIETIES: New Jersey Floricultural Society—North Shore Horticultural Society—New York Florists' Club— Gardeners' and Florists' Club of Boston—Pittsburg Florists' and Gardeners' Club—Chicago Florists' Club	330
Florists' Club of Washington—F. H. Kramer, por- trait	331
American Rose Society—Worcester County Horti- cultural Society	332
Spring Flower Show—Some Toledo Florists— Southampton Horticultural Society.....	333
OBITUARY—Henry F. Rauss—Austin Craig Apgar— Rob't B. Lenchars—Wm. Sabin—Allen Dodge— Frank Cummings, Sr.—Prof. Kellerman—John E. Mitchell	333
THE PRIVATE GARDENER—Robert Craig.....	331
SEED TRADE	338
Wholesale Seedsmen's League.....	338
Plant Imports	339
Catalogues Received	339
BY WIRELESS FROM ROBERT CRAIG	340
OF INTEREST TO RETAIL FLORISTS.....	342
New Retail Flower Stores.....	343
FLOWER MARKET REPORTS: Boston—Buffalo—Chicago—Detroit—New York— Philadelphia—Twin Cities—Washington	345
SOLUBLE FERTILIZERS—George A. Bishop.....	353
MISCELLANEOUS: Hex Crosses	329
Some Wise Advice.....	329
Carnation Exhibition at Cornell.....	337
Fire Record	337
Publications Received	337
Business Changes	343
Personal	343
News Notes	343
Toledo Notes	345
A Daily Plant Auction	345
Catalogues Received	353
Greenhouses Building or Contemplated.....	354
List of Patents	354

HORTICULTURE's value to the progressive Reciprocity culturist is well recognized. Advertisers know it and the liberality with which they use its columns is good evidence that they are aware the paper is read by the best buying element in the trade. Nevertheless we are far from satisfied. The usefulness of HORTICULTURE would be vastly increased if every reader would help by contributing little items of experiences, the reading of which would help his fellow-grower or dealer, or by asking questions on points concerning which he himself feels the need of advice. There is an unlimited amount of knowledge and experience tied up in the heads of gardeners and florists which, if given out freely, would be of immense practical benefit to others, yet would work no injury to the interests of the giver.

One of the daily papers expresses regret at the decadence of the sense of chivalry of a generation back when etiquette demanded that flowers be sent always to a hostess before even the least formal entertainment and when a debutante had better stay at home than go to a ball without a bouquet of flowers. We are in full sympathy with the sentiments expressed by our contemporary, and no doubt our readers will also agree unanimsly. One cannot but wonder where all the flowers which are produced in such overwhelming profusion by the wholesale growers go to, especially when we consider how little evidence is in sight as to their use. Perhaps the pendulum may swing back again to the conditions that prevailed years ago and fresh flowers be once more recognized as an indispensable feature of every social affair, large or small. When it does, what a wealth of beauty the flower growers will be able to place at the disposal of their patrons as compared with the productions of the olden time!

Another glaring manifestation of retrogression and degeneracy is the use of artificial plants and flowers for the adornment of hotels and other places of public resort. Just how far our plant growers and dealers are responsible for the existence and prosperity of establishments devoted to the sale of artificial material we shall not attempt to say. It is doubtless true that disheartening experience with plants of delicate texture or unfitted for exposure through overforcing or other improper treatment has had its effect on those who should be buyers of quantities of fresh material but, whatever the reason may be, the present tendency to indulge in make-believe floral material when there is such an abundance of the natural product, calls for deliberate reflection and consideration as to the best means for directing public appreciation on right lines and bringing discredit on all forms of horticultural shams. And we might add that so long as the florist trade itself can be caught "with the goods on," in the form of green-dyed carnations or painted cycas leaves it is hardly in position to do much effective fighting on the right side.

AFTER ADJOURNMENT.

We have to apologize to our readers, a number of whom have told us of their fruitless search through the columns of our last issue for the "Private Gardener" paper, by Robert Craig, to which we called attention editorially. Late advertising copy was the cause of the holding over of Mr. Craig's paper until this week, and unfortunately we neglected to change our editorial line accordingly for all of which remissness we beg pardon.

We frequently hear predictions of the return of the camelia to its old time popularity with the flower buyers. That it will ever regain its prestige as a short stemmed cut flower to be wired and used flat in floral work we think very doubtful but that it will yet take a high place in the list of choice long-stemmed cut flowers as well as in small neatly grown blooming plants seems inevitable when one sees some of the beautiful new varieties offered such as are in evidence at the greenhouses of Julius Roehrs Company at the present time. One of the loveliest flowers is Reticulata, a brilliant colored single variety with large wavy petals resembling a fine hibiscus. Among the best of the double forms is Elegans Chandleri rose-pink often irregularly variegated and spotted with white.

A SONG FOR MARCH.

Who sings of March, must sing the mad,
Lone man-at-arms, the straggler clad
In motley white and brown—
Who in the wake of Winter's flight
Turns now to eager, now to fight—
Half hector and half clown,
One moment from a cloud-capped hill
He blares his slogan, wild and shrill;
The next with gusty laughter,
Outsteps the sunbeams as they dance,
And leers and flouts, with backward glance,
The maid who follows after.
O! sing the maid,
The light-heart maid,
Who follows, follows after.

He flees her down the lengthening days;
She follows him through woodland ways,
O'er hills and vales between,
And sets for mark of victory
On every bush and hedge and tree
Her flag of tender green;
And when her breath hath spiced the night
With promise of the warm delight
Of young June's love and laughter,
No other song may true hearts sing
But "Speed thy passing, March, and bring
The maid who follows after;
The light-heart maid,
The lily maid,
Who follows, follows after."
—T. A. Daly, in Catholic Standard and Times.

The above beautiful lines will delight the poetic soul. Shakespeare's glorious flash of imagination: "When well appareid April on the heels of limping winter treads," has here been supplemented with a new thought—piebald March—blustering—laughing—running; an original conception.

"Are as well satisfied with results from your paper as any."

WHITE BROS.

Gasport, N. Y., March 9, 1908.

"THE JAPANESE SHAMROCK."

March is here, blowing and spluttering. In a week or two we may look for the hepaticas. Meantime I am cheered even now, while the snow lies in my back yard, by the Japanese emblem of good luck—(Adonis Amurensis)—its green and golden flowers making a lovely patch of color above finely cut, fern-like foliage of the deepest green. This is the earliest-flowering hardy perennial in existence and a charming thing that everybody ought to have. As it is the Japanese "good luck plant" we might be justified in making an Irish bull out of it and calling it the Japanese "Shamrock." I got my first plant of it from J. D. Eisele of Drees's and his good words for it have been amply borne out by experience.

G. C. WATSON.

THE IRISH SHAMROCK.

Strictly speaking, the word "shamrock" is not Irish but comes from the Arabic "shamrakh" signifying trefoil. Most commentators start out with St. Patrick however, and ignore the fact that the shamrock was held sacred in Iran and was emblematic of the Persian triad long before St. Patrick's day. St. Patrick used the plant to illustrate the trinity in unity to the early Christians. What plant he used nobody knows. Keough, Threlkeld, and other Irish botanists assert that Trifolium repens (white clover) is the true Irish shamrock and will have nothing to do with that "little, sour, puny plant, the Wood Sorrel," which Mr. Picheno and others have favored. Loudon favored the black medick (Medicago lupulina). Croker points out that as far back as 1689 the Irish themselves considered shamrocks and sorrel as entirely distinct. The "Irish Hudibras" printed in 1689 sings of "Springs, happy springs adorned with sallets,
Which nature purpos'd for their palats;
Shamrogs and waterless he shows,
Which was both meat and drink and clothes."
and further along the Irish are represented as

"Without a rag, trouses or brogues;
P'cking of sorrel and sham-rogues."

In another ancient Irish poem the "Hespero-neso-graphia" the following passage occurs:

"Beside all this vast bundles came
Of sorrel, more than I can name,
And many sheaves I hear there was
Of shamrocks, and of water grass."

Dr. Withering and Professor Rennie both favored the white clover as St. Patrick's plant, and from its commonness and the likelihood of the Saint taking the first three-leaved plant he came across to illustrate his meaning there can be little doubt that the white clover is the genuine Irish shamrock.

"The sweet little, green little, Shamrock of Ireland" has a sentimental significance, however, outside of the religious. Next to—

"Sublime potatoes, that from Antrim's
To famous Kerry, form the poor man's
store."

it is probably the most universally distributed plant we know and one of the most useful—besides typifying to us all that is charming and lovable in

the Irish character—a race that blends in happy unison.

"Three godlike friends,
Love, Valor, Wit, forever."

At the present time the shamrock is as popular in London as in Dublin town or New York City and is therefore emblematic of the improved sentiments of imperial comity and good feeling which peace-loving citizens of the universe so rejoice to see. We can all heartily subscribe to the sentiment of the old song:

"The plant that blooms forever
With the rose combined
And the thistle twined,
Defy the strength of foes to sever.

"Firm be the triple league they form,
Despite all change of weather;
In sunshine, darkness, calm or storm,
Still may they fondly grow together."

The 17th of March will be here in three days, and it behooves every florist to have plenty of shamrocks for that day as the demand is sure to be greater than ever before. They will sell on sight. But you cannot sell them unless you show them properly.

GEORGE C. WATSON.

ILEX CROSSES.

Two beautiful species of Ilex are common in the fields of New England. The winter-berry, Ilex verticillata, which holds its bright red fruit well into the winter, and Ilex glabra, which bears black fruit, but holds its leaves bright and green throughout the winter. If the red fruit of the one could be as abundantly produced among the green foliage of the other as it normally is in the leafless species, we should have a most pleasing ornamental shrub. A number of attempts have been made to cross the two species, but in every case without result. Mention is made of some of these attempts in the annual report for 1903. As a practical means of securing much the same effect the two species may be planted together in such close contact that the red berries are intermingled with the green leaves and an excellent result obtained.—F. W. Card in Report of R. I. Agri. Exp. Station.

SOME WISE ADVICE.

Don't sell your goods on longer time than you buy them.

An advertisement without a price is like a story without a climax.

A small territory well worked is more profitable than a large farm poorly cared for.

The demand is insatiable and constantly growing for modern and improved implements.

Girls and business are very much alike. The more coy they are the more sedulously we must court them.

Is it true that your business is transacted in an illogical and unbusinesslike manner? If so a change is desirable.

Newspaper space should be fertilized with brains, planted with desirable goods, cultivated with attractive prices, and it will yield a rich harvest of profitable sales.—Implement Age.

"Enclosed you will find check in settlement of your bill to date and we will ask that you kindly discontinue ad. in Buyer's Directory as we have about sold all tuberoses."

T. V. RIVENBARK.

Wallace, N. C.

HORTICULTURE

NEWS OF THE CLUBS AND SOCIETIES.

NEW JERSEY FLORICULTURAL SOCIETY.

The monthly meeting of this society was held on the 6th instant. The evening was observed as a "Carnation Night", and thirty-three vases of the divine flower, with orchids and roses, bore evidence of the strength of the society in strong men. Many were kept away by the storm, but the rooms were crowded from an early hour until near eleven o'clock. W. A. Manda's vase of a hundred blooms of his new pink seedling No. 29, soon to be introduced by John N. May, attracted much attention, and its possession of every quality except extra size promises to make it a particularly valuable commercial sort. Its merits were recognized by a certificate reward. John E. Haines of Bethlehem, Pa., was present with his Imperial and John E. Haines. James D. Cockeroff of Northport, L. I., sent Harvard and Oscar Carleson, Fairfield, Conn., his No. 14 Seedling.

Contributions from neighboring estates were in force. Among the gardeners exhibiting carnations were John Hayes, George Oakley, William Reid, D. Kindsgrab, Max Schneider, Peter Duff and Phillip Cox. Roses and sweet peas were shown by John Gervin, antirrhinums by Frank Drew, cinerarias, cyclamens and violets by Max Schneider. Lager & Hurrell showed orchids, including *Odontoglossums crispum* and *Cervantesii*, *Dendrobiums splendidissimum* and noble *Rothwellianum*, *Laelio-Cattleya Pallas* and *Oncidium fuscatum*. Julius Roehrs Company showed *Cattleya Schroderae* var. *Surprise* and rose Newport Fairy.

A strong sentiment prevailed to continue special flowers nights through the season and W. A. Manda placed ten dollars in the hands of the treasurer for cash prizes. L. B. DAVIS.

NORTH SHORE HORTICULTURAL SOCIETY.

This society held its regular meeting in Manchester on March 6. Pres. William Till in the chair.

The speaker of the evening was Robert Cameron, of the Botanic Gardens, Cambridge, the subject being "Annuals." Mr. Cameron treated the subject under the following heads: Origin of annuals; Geographical distribution; Improvement by selection of breeding; Usefulness of annuals; Importance of good seed; Cultivation; Popular annuals; Annuals that deserve a greater popularity; Best for cut flower; Varieties suitable for bedding and massing; seashore and mountain varieties; Best kinds for school gardens; Climbing annuals; Biennials.

A vote of thanks was extended to Mr. Cameron for the very able and thorough manner in which he treated this extensive and interesting subject. James Salter was awarded a certificate of merit for a vase of White Antirrhinum

NEW YORK FLORISTS' CLUB.

The monthly meeting on the evening of March 9 was not as fully attended as usual there being less than fifty members present but it was a good and interesting meeting from start to finish. Prof. L. C. Corbett, from the Agricultural Dept., Washington, gave an instructive talk on "The Preparation of Soil for Greenhouse Purposes." The lecture drew out an animated discussion, participated in by Patrick O'Mara, E. V. Hallock, W. B. Du Rie and John Birnie all of whom had been handling soil for "Lo, these many years" and were sure they knew something about the subject with which their earthly career had been so closely linked.

Among the most important transactions of the evening was the practical organization of a bowling team for active service for the coming year and serious business at the Niagara Falls Convention especially next August. President Weathered will deliver a silver cup to the team if it wins at Niagara and President Traendly offers free transportation to a team of five members who in a series of practice games are able to show an average score of 155. Ten aspirants were at once enrolled and the prospects are that there will be something doing in New York before long. All those who wish to join the aggregation may send application to W. E. Marshall, 146 W. 23d St., New York. Dinner committee, outing committee, etc., all made satisfactory reports. Messrs. Young, Bunyard, Traendly, Withers and Totty were constituted transportation committee for convention.

The following exhibits were staged for the inspection of the members. Wm. Eccles, Oyster Bay, carnation Beacon, so good that a cultural certificate was awarded. New Polyantha rose Apple Blossom from Anton Schultheis received a preliminary certificate. Seedling carnation from W. A. Manda, scored 76 points. A. T. Boddington showed *Primula Sieboldii* and *Queen of the Whites* and received the thanks of the club therefor.

GARDENERS' AND FLORISTS' CLUB OF BOSTON.

The next regular monthly meeting of the club will be held at Horticultural Hall, Boston, on Tuesday evening, March 17, 1908, at 8 o'clock. The lecturer will be Mr. Eber Holmes of Montrose Greenhouses on the important subject of "Indoor Commercial Rose Culture." W. H. Elliott and other prominent rosarians will take part in the discussion. There will be interesting exhibits and a general good time for all who attend.

The annual club banquet will be held at Horticultural Hall on April 1, 1908. There will be a first-class menu served by a well-known caterer, entertainment and dancing. Tickets, \$1.50 each, are obtainable from Peter M. Miller, 22 South Market St., to whom all applications should be made. An attendance of 300 is expected at this banquet, which it is planned to have eclipse all its predecessors.

W. N. CRAIG, Sec'y.

PITTSBURG FLORISTS' AND GARDENERS' CLUB.

The enthusiasm and large attendance which marked the February meeting of the club seemed to carry over to the meeting March 3rd, for from early in the evening there was standing room only. There seems no doubt that the policy of offering prizes, cultural certificates and awards of merit, while appealing to all the members, is of special force with the private gardeners, evidenced among other things by the fact that in the last two months 15 new members have joined, mostly private gardeners. It is worth something to a gardener to be able to show his employer a prize won in open competition at his club meeting. It, so to speak, stamps the man with the approval of experts in his own line, and is likely to call an employer's attention to the fact that he has a good man.

The private gardeners at the February meeting presented a provisional schedule of prizes for exhibition of private gardeners, covering the period from June, '08, to May, '09. This schedule was referred to the March meeting for disposition, and was approved and adopted. It provides for a competitive exhibition of seasonable flowers for each month excepting August.

There was a good display of blooming plants in pots and of cut flowers. An exhibit of tulips by H. L. Blind & Bros. brought out some remarks on Holland bulbs, especially in relation to bulbs of the same size and kind, giving such a density in size of spike. A representative of a Holland grower of bulbs who was present took the ground that the difference was unaccountable; that it was inherent in the bulbs, and on the same principle that children of the same father and mother frequently show such a difference in size.

Awards to Private Gardeners: N. C. Madsen, special mention for *Cineraria radiata*; David Fraser, special mention for *Primula obconica*.

Awards to Commercial Growers: Heiman Heim, first prize for azaleas; H. L. Blind & Bros., second. H. L. Blind & Bros., first for tulips. Herman Heim, first for Baby Rambler roses. Subject for next meeting, "Easter Plants and Flowers."

H. P. JOSLIN, Sec'y.

CHICAGO FLORISTS' CLUB.

The Chicago Florists' Club held a special meeting March 5 at Union Restaurant in place of the regular meeting due March 13th. Mr. Poehlmann, manager of the rose show, spoke on the progress being made by the committee. A change of meeting night and place was discussed and everyone heartily approved of the present innovation. An intermission was had for an hour and refreshments were served.

The dinner scheduled by the Florists' Club of Philadelphia for the 11th inst. has been postponed indefinitely. The reason given is lack of interest among the members.

FLORISTS' CLUB OF WASHINGTON

The monthly meeting of this club was held March 3rd at Gude's Hall. Officers for the ensuing year were elected as follows: F. H. Kramer, president; John Robertson, vice-president; Chas. McCauley, secretary; Wm. F. Gude, treasurer; directors, Peter Bisset, Chas. McCauley, George Shaffer, Wm. F. Gude, John Robertson; awards committee, John Robertson, Chas. McCauley, J. W. Freeman and George Cooke. F. H. Kramer showed a large vase of Queen Beatrice rose, and Peter Bisset a vase of his new seedling rose "G. B." W. P. Craig of Philadelphia showed a vase of Mrs. Jardine. The awards committee will report upon above exhibits at the next meeting.

Another out-of-town guest was Robert R. Jones of Harrisburg, Penn., who represents the Morehead steam-trap, of which he gave an interesting explanation. He also showed several new electric lamps which will soon be put upon the market, and which are said to be a great improvement over the present incandescent light.

A very pleasant feature of the April meeting will be the annual banquet, which is always tendered the new officers. The committee on arrangements consists of Geo. H. Cooke, chairman, Z. D. Blackstone and Geo. Shaffer.

One of the most enjoyable features of the meeting was the address of the retiring president, Peter Bisset, of which the following is an abstract:

"It is now two years since you elected me president of this organization. At that time I promised with your help to see that the club did not go backwards but forward. You, gentlemen, who have watched the work of the club closely and who are familiar with all that has been accomplished will, I am sure agree with me that we have gone forward. Today the awards

of this club are thought as highly of as those of any other society in the universe. This has brought to our exhibitions flowers and plants from many sections all striving for the recognition of this club in its medals or certificates. It rests with you, gentlemen, to see that these awards shall be as hard to secure in the future, as they have been in the past, for, the moment they are cheapened in any way, or awarded to plants or flowers not of high standard, their value will deteriorate.

"During my term as your president the constitution and by-laws have been revised and many new features added, one of the most beneficial to the work of the club being the creation of a board of directors, who have been faithful in their attendance, and I wish now to extend my thanks to these

gentlemen for advice and help in solving the many problems that came before us. Another innovation was the appointment of the committee of awards: the gentlemen who have served on this committee have always acted in a conscientious manner and I cannot pay them a higher compliment than to say I have yet to hear the first word of adverse criticism on the awards made by them.

"At the meeting held on April 3, 1906, the club voted unanimously to extend an invitation to the American Rose Society to hold its convention and exhibition in this city in 1907. This invitation was accepted and we had an exhibition of roses which surprised all who were privileged to see it and was very creditable for this section.

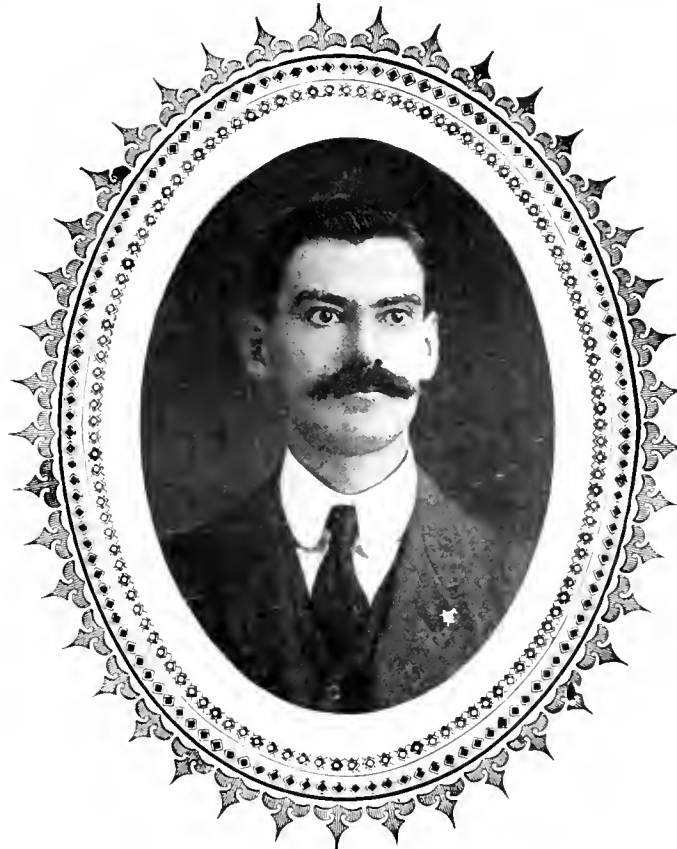

F. H. KRAMER

President-elect Florists' Club of Washington.

This exhibition was followed by a dinner to the delegates and their ladies which fully bore out the reputation of the Washington florists for their good fellowship and generosity. Another wise step taken by the club was in offering a gold and silver medal and two certificates to the best school garden. This created quite an interest and rivalry among the schools and no doubt will benefit the florists of this city a hundred-fold through the love of flowers that those awards helped to develop. I believe the club should award the same number of medals and certificates every year to the schools.

"A series of lectures was also inaugurated and we expected great things from them. It was decided to admit the public to them free of charge. Mr. J. K. M. L. Farquhar of

Boston came and gave a lecture on the flora of Japan which was appreciated by those present. The lectures had to be abandoned, however, as we were not in a position to pay for suitable halls. I hope that at no distant date the club may find a hall free of rent where such lectures can be given to the public free of charge, which I feel sure would be of lasting benefit. I would also suggest that the exhibition of dabbias, roses and carnations that have been held for the past few years be continued. To me personally these exhibitions have been of great benefit, and from what others have told me they also have secured valuable information from them. Abuse of the privilege thus offered can be guarded against by the issuance of admission tickets to all our members for distribution to their friends. The club held a fall show last November, successful in every way but the door receipts.

"Last summer the club enjoyed one of the most delightful affairs in its history. I refer to the outing to the Great Falls of the Potomac; this outing brought together all the florists with their wives and friends from all sections of the District and outlying suburbs. On January 28-30 we had the pleasure of entertaining the American Carnation Society in convention in our city. In connection with the convention there was held at the National Rifles' Hall one of the finest displays of carnations it has ever been my good fortune to see. The club gave the visiting members and their ladies a dinner at Rauscher's on the night of January 30, which was a very pleasant affair and elicited many words of praise from the guests. This concludes the most important events of my term of office as your president.

"The club is at this time better equipped to carry on its work than ever it was; our membership is strong, composed of the men who lead in our business, men that to be associated with is an honor and a pleasure, and there is little danger of the club going down as long as it has the strong support of men who are always ready to give of their means as well as their time and counsel to further the work of the club. I would say to those gentlemen who have always stood by me during the years I have been in office and who have never refused to help whenever requested to do anything for the good of the organization,—Give the gentlemen who will follow me the same help and encouragement that you have given to me, and this club will go on gaining in strength and usefulness.

AMERICAN ROSE SOCIETY

Special Prizes.

The large list of Specials betokens a most creditable interest in the coming Rose Show. August F. Poehlmann, Morton Grove, Ill., is manager, George Asmus, 579 West Madison St., Chicago, Ill., is assistant manager, and will be in charge of exhibits in Art Institute, Michigan Ave. and Adams Street, Chicago, Ill., March 25, 26, 27.

Send an application for entry to T. E. Waters, secretary of the Chicago Florists' Club, 21 E. Randolph street, or file with Benjamin Hammond, secretary of the American Rose Society. A supplementary list is ready for all interested persons. It is urgently desired that all intending exhibitors will let the committee know early what they will send. Last year at Washington exhibitors delayed doing this until the very last day in the afternoon, and the result was that the beautiful show which ensued, was really not known until it was on the ground, and this rush made it hard work to handle.

Division F.—Special Prizes for Cut Blooms, Etc.

F. 145. Fifty Blooms American Beauty Rose. American Rose Society's prizes, \$50, \$25.

F. 146. Display of cut Roses, all varieties. Challenge prize, valued at \$250, offered by Benjamin Dorrance; the winner to hold the prize a year and on relinquishing it to the society for another competition at the end of that period to receive a silver shield suitably engraved as a permanent record of his having held the prize. The names of the winners will be engraved consecutively on the prize.

F. 147. Outdoor Roses in bloom—in pots or tubs. \$200 cash for first prize, by Philip Breitmeyer of Detroit; \$100 cash for second prize, by Arthur T. Boddington, of New York City. Exhibits to consist of 150 plants, not more than five plants of one variety; each to be correctly labeled. All types and classes suitable for out-of-door planting may be included.

F. 148. Vase of one hundred Richmonds, \$50 in gold, offered by E. G. Hill Co., Richmond, Ind.

F. 149. Fifty Blooms of any Rose of American origin now in commerce. Silver cup, value \$25, offered by Alexander Montgomery, Natick, Mass.

F. 150. For the largest and most varied collection of Cut Roses of all classes, one or more blooms in a vase, the variety to count 65 points. Silver cup or \$25 in gold, offered by W. A. Manda, South Orange, N. J.

F. 151. Twenty-five Blooms of La Detroit. Prize of \$25 offered by John Breitmeyer's Sons, Detroit, Mich.

F. 152. The Vase of Roses showing the most artistic arrangement in the exhibition, \$25 offered by Welch Bros., Boston.

F. 153. For the most beautiful exhibit in the hall, a prize of \$20 in gold is offered by Miss M. L. Hammond, Fishkill-on-Hudson, N. Y. Each lady visiting the exhibition the first day to cast a vote on leaving the hall and the exhibit receiving the largest number of votes to receive the prize.

F. 154. One hundred Blooms of Killarney, \$50 offered by Robert Simpson, Clifton, N. J.

F. 155. Fifty Blooms of Liberty, \$25 offered by Adolph Farenwald, Hillside, Pa.

F. 156. Fifty Blooms of Killarney, \$25 offered by Tinglee & Conard Co., West Grove, Pa.

F. 157. Fifty Blooms of Bridesmaid, \$25 offered by Traudly & Schenk, New York.

F. 158. Fifty Blooms of Bride, \$25 offered by Emil Baertner, Park Ridge, Ill.

F. 159. Fifty Blooms of Liberty, \$25 offered by John Davis Co., Chicago.

F. 160. Fifty Blooms of Kaiserin Augusta Victoria, \$25 offered by The Globe Coal Co., Chicago.

F. 161. Fifty Blooms of Golden Gate, \$25 offered by J. A. Bullong, Chicago.

F. 162. Fifty Blooms of Ivory, \$25 offered by J. F. Wilcox, Council Bluffs, Iowa.

F. 163. The best one hundred Blooms of Pink Roses in the show, \$50 offered by Poehlmann Bros. Co., Chicago.

F. 164. Fifty Blooms of Red Roses, Richmond and American Beauties excluded, \$25 offered by Poehlmann Bros. Co., Chicago.

F. 165. One Hundred Blooms of Richmond, \$50 offered by Poehlmann Bros. Co., Chicago.

F. 166. One Hundred Blooms of Kate Moulton, First prize, \$25, offered by Wieter Bros., Chicago. Second prize, \$20, offered by Geo. Reinberg, Chicago.

F. 167. One Hundred Blooms of Uncle John, \$25 offered by Wieter Bros., Chicago.

F. 168. One Hundred Blooms of Mad. A. Chateau. Silver Cup, value \$25, offered by Vaughan's Seed Store, Chicago.

F. 169. Fifty Blooms of American Beauty, \$50 offered by The Mogz Coal Co., Chicago.

F. 170. One Hundred Blooms of Bride, \$25 offered by The Pulverized Manure Co., Chicago.

F. 171. One Hundred Blooms of Sunrise, \$25 offered by The Florists' Review, Chicago.

F. 172. Twenty-five Blooms of Bridesmaid exhibited by growers having less than 50,000 square feet of glass, \$25 offered by Basset & Washburn, Chicago.

F. 173. Twenty-five Blooms of Bride exhibited by growers having less than 50,000 square feet of glass, \$25 offered by Basset & Washburn, Chicago.

F. 174. One Hundred Blooms of Mrs. Porter Palmer, \$50 offered by S. Freeman & Sons, Chicago.

F. 175. The best new Rose not in commerce and never exhibited before the American Rose Society, vase to contain not less than twelve and not more than twenty-five Blooms. Silver Cup, value \$25, offered by F. R. Pierson, Tarrytown, N. Y.

F. 176. Fifty Blooms of American Beauty, Cyclopedic of American Horticulture by Prof. L. H. Bailey, value \$30, offered by The American Florist Co., Chicago.

F. 177. Best Twenty-five Blooms of Pink Roses not disseminated prior to 1908. Silver Cup, value \$15, offered by J. R. Denard Co., Chicago.

F. 178. Twenty-five Blooms of Bridesmaid, \$10 offered by W. W. Barnard Co., Chicago.

F. 179. Twenty-five Blooms of Richmond, \$10 offered by Geo. Keller & Son, Chicago.

F. 180. Twenty-five Blooms of Sunrise, \$10 offered by Leonard Kill, Chicago.

F. 181. Twenty-five Blooms of Uncle John, \$10 offered by I. R. Newbold, New York.

F. 182. Twenty-five Blooms of Killarney, \$10 offered by Kroeschell Bros. Co., Chicago.

F. 183. Twenty-five Blooms of Bride, \$10 offered by A. Dietsch Co., Chicago.

F. 184. Fifty Blooms of Mad. A. Chateau, \$10 offered by Welland & Olmger, New Castle, Ind.

F. 185. Fifty Blooms of American Beauty, Two tons of Florist Bone offered by Darling & Co., Chicago.

F. 186. Twelve named Varieties of Hybrid Perpetuals in pots, \$10 offered by Kroeschell Bros. Co., Chicago.

F. 187. Twenty-five Blooms of Killarney, \$10 offered by Holten & Hunkel, Milwaukee, Wis.

F. 188. Exhibit of cut Roses, four varieties, Twelve Blooms of each variety, open to Private Gardeners only, \$25 offered by Harry O. May, Summit, N. J.

F. 189. Two Hundred Lily of the Valley, First prize \$10, offered by H. N. Bunn, Chicago. Second prize \$8, offered by Poehlmann Bros. Co., Chicago.

F. 190. Vase of One Hundred American Beauties, Silver Cup, valued at \$10, offered by Crane & Co., Chicago, Ill.

F. 191. Best Fifty Blooms of new Rose never before exhibited for competition, Silver Loving Cup, valued at \$20, offered by Holter Bros., New Castle, Ill.

A. L. Randall Co., 21 E. Randolph street, will receive and take care of any flowers sent for exhibition.

BENJAMIN HAMMOND,

Secretary.

Fishkill-on-Hudson, N. Y.

WORCESTER COUNTY HORTICULTURAL SOCIETY.

At the last lecture of the season on March 5, Philip W. Ayres gave an illustrated talk on Forestry which was thoroughly enjoyed by a large audience. The exhibition of flowers and plants was large and of excellent quality. H. F. A. Lange, E. W. Breed and M. J. Whittall had some handsome azaleas. Roses and carnations were shown by Messrs. Lange and Midgley. George McWilliam had some fine orchids. There were cinerarias, primulas, cyclamens, hyacinths, etc., mainly from the above named growers.

The "Heart of the Commonwealth" throbbled with rural happiness on the occasion of the annual banquet and reunion of the Worcester County Society on the evening of March 11. It was held in the banquet hall of Horticultural Hall and there must have been nearly four hundred ladies and gentlemen in attendance. The banquet hall was not large enough to accommodate all the guests, and tables were set in adjoining rooms and one in the main hall.

From 6 to 6.30 the guests were received informally by President George Calvin Rice, Secretary Adin A. Hixon, Treasurer Charles S. Bacon, A. H. Lange, George McWilliam, Leonard C. Midgley, Henry B. Watts, Charles Greenwood, Arthur E. Hartshorn, William J. Wheeler, Simon E. Fisher, H. R. Kinney, H. A. Cooke, E. W. Breed, Charles W. Wood, J. Lewis Ellsworth, Arthur J. Marble, A. N. Powell, W. K. Stanley, E. A. Bartlett, A. A. Bellows, F. H. Hammond, H. E. Kinney, M. F. Converse, George B. Rich, Allyn W. Hixon and George W. Hixcox.

The tables were decorated with plants and cut flowers furnished by Edward W. Breed, A. H. Lange, Leonard C. Midgley and Adin A. Hixon.

There was a new toastmaster this year, John B. Bowker. The after-dinner program, arranged by him and Secretary Hixon, was one of the most enjoyable in the history of the society. For the first time musical numbers were mixed in with the speeches. Each speaker was introduced with appropriate and witty remarks. Mr. Bowker spared nobody, and, consequently, none of the speakers spared him.

President Rice said, in part: "The committee on winter meetings, lectures and discussion closes its duties with tonight's entertainment, and I wish to thank it for the conduct of those meetings, that some one or more have been present at each meeting to welcome all, also those who took part in the subject of the day. Your committee introduced a new feature—that of music at several meetings—which gave universal satisfaction, and I wish to thank those who took part most heartily."

"The program for tonight includes speaking and vocal music, introduced by the toastmaster, and at 9.15 o'clock we adjourn to the lower hall, where all are invited and expected to join the dance—A. J. Marble, floor director."

The speeches that followed were witty and full of entertainment.

Among those who spoke of their work, and told entertaining stories were, C. S. Gold, president of the Connecticut Pomological Society; I. L.

Harvey, vice-president of the New Hampshire Horticultural Society; J. W. Clark, the new president of the Massachusetts Fruit Growers' Association; Prof. F. C. Sears of the Massachusetts Agricultural College; Edwin H. Burlingame, secretary of the Rhode Island Horticultural Society; Dr. Geo. M. Twitchell of Augusta, Me.; A. Warren Patch of Boston, and Joseph K. Greene. The Midgley Quartet, composed of Leonard C. Midgley, Mrs. Harry Hildreth, and Mr. and Mrs. Percy G. Forbes, sang selections, while Mr. Forbes and Mr. Midgley sang two duets. The exercises closed with a selection by the quartet.

The guests adjourned to the main hall, where the Light Infantry Orchestra played for dancing until 12 o'clock.

SPRING FLOWER SHOW.

The annual spring flower show of the Massachusetts Horticultural Society will be held at Horticultural Hall, Boston, Friday to Monday, March 20 to 23.

The displays of spring bulbous plants, including tulips, narcissi, hyacinths, and lilies, at this exhibition will exceed in magnitude and brilliancy any previous efforts of the Society.

Other notable features will be the collections of Easter flowering plants, herbaceous spiraeas, acacias, azaleas, ericas, and orchids from private estates in the vicinity of Boston, while many commercial floriculturists of this and other States will contribute the best products of their greenhouses.

Roses, carnations, and violets will be largely represented and the schedule calls also for collections of winter apples and vegetables.

In response to an often expressed desire by visitors to the Society's exhibitions and to increase their educational value a professional expert gardener will be in constant attendance to answer questions and to furnish information concerning the exhibits.

There will be music by a ladies' orchestra of eight musicians every afternoon and evening from 3 to 5 and from 7.30 to 9.30.

The exhibition will open Friday, March 20, at 12 o'clock, continuing until Monday, March 23, from 10 a. m. to 10 p. m.

WM. P. RICH, Secretary.

BUFFALO FLORISTS' CLUB.

On the evening of Friday, March 6th, the Buffalo Florists' Club held their annual banquet, smoker and election of officers. Not only in numbers, but in every other respect, the meeting and banquet were the most successful in years.

After the installation of officers and the regular routine of business had been transacted, the members enjoyed the smoker immensely; there was something doing every minute. All features of the entertainment were excellent, and the committee is to be congratulated on securing such talent as was had.

Louis Neubeck, acting as toastmaster, was of rare worth and held the attention of the members throughout. The first speaker of the evening was William Legg, the Club's past secretary, whose remarks were interesting and to the point. Among the other

members who were heard from were William Scott, William F. Kasting, Charles Keitsch and others.

E. C. B.

SOME TOLEDO FLORISTS.

The Florists' Club visited last Sunday afternoon the establishments of C. Kaminski, John Gratopp, Harry Hehl and Chas. Koelker & Sons. Kaminski has two houses and caters to the retail trade. Gratopp's range, which is quite extensive, is planted mostly in carnations, which are in solid benches, fringed by parsley, mainly for the looks of it, for parsley does not pay this year. A large house, 4x100, erected late last fall, is intended for roses, but at the present time contains lettuce. At Hehl's houses, about the largest place in town, the cut of roses and carnations has been very satisfactory. Mr. Hehl is a strong believer in pot-grown carnations. He grows also a large amount of bedding plants, which are sold every year at planting season for 5c. each, no pots and no delivery. Chas. Koelker & Sons' place is taken care of by his two boys. Roses and carnations are the main crop besides bedding plants, etc., as used in every retail store.

SOUTHAMPTON HORTICULTURAL SOCIETY.

The bi-monthly meeting of this society was held March 5th. President Clark in the chair. After the election of members and other routine business J. Griffin read a very interesting paper on Vegetable Growing, which was followed by a profitable discussion. It was decided to hold a banquet after our next meeting, Thursday, March 19th.

U. G. AGER.

AN ASTER GROWING CONTEST.

Entry to Altimo Culture Co.'s \$250.00 Prize Aster Growing Contest is **Free to All**.

We desire to inform those who have received our Aster Book, that the condition requiring competitors to purchase some part of their seed from us is **no longer required**. We will send a card for entry **Free**—whether you buy seed from us or not—Similar varieties to those grown from "Altimo" Brand Seed will be considered in competition for the regular prizes; and any variety superior to "Altimo" Brand Varieties will be considered in competition for the special prize.

If you have good seed of fine varieties you stand in a good way to win provided you are a good grower. If your varieties are **run out** then you better get some first class seed from us. At any rate, we leave this to you, but **we want you to compete** for the prizes.

We want a lot of competitors for our prizes; a big contest, that the prizes will really go to the **best Aster Growers in America**. This can only be provided the best Aster Growers compete for the prizes. Some of the best have already approved our plan and express enthusiasm over it and we appreciate the same, but we want to hear from **every Aster Grower in America**, so write for competition card today.

Yours for success,
ALTIMO CULTURE CO.,
Canfield, Ohio.

Obituary

Henry F. Rauss.

Henry F. Rauss, of Detroit, Mich., died on February 26, aged 49. He was connected with the greenhouses at Belle Isle previous to his long illness. A widow and children survive him.

Austin Craig Apgar.

Prof. Austin Craig Apgar, a prominent botanist, died at his home in Trenton, N. J., on March 5. He was an extensive contributor to periodicals and the author of several books on trees.

Robert B. Leuchars.

Robert B. Leuchars, a well-known writer on subjects horticultural and floricultural, died in Brookline, Mass., aged 85. He retired from active business as a landscape gardener some twenty-five years ago.

William Sabin.

William Sabin, of Bridgeport, Pa., died on February 26, aged 72. He was born in Staffordshire, England, but since 1888 had been in this country, first as florist, and later as sexton of the Bridgeport cemetery.

Allen Dodge.

Allen Dodge, the oldest employe of the Department of Agriculture in Washington, died at his home in that city March 6 at the age of eighty-five years. He was a native of the District of Columbia and had been a pomologist in the department for twenty-seven years.

Frank Cummings, Sr.

Frank Cummings, Sr., died in Meridian, Miss., on February 23, at the age of 83. Mr. Cummings was at the head of the Frank Cummings Bulb & Plant Co., having conducted this business for seven years. A son and two grandsons now comprise the firm, and they will retain the title as it now stands.

Prof. Kellerman.

Word has been received from the American minister at Guatemala City of the death last Sunday of malarial fever of Professor Kellerman, head of the botanical department at the Ohio State University, who was studying the flora there. He was 50 years old and a graduate of Cornell University.

John E. Mitchell.

John E. Mitchell, who for many years has conducted extensive greenhouses in Beverly, Mass., passed away on March 3, at the age of 71. Mr. Mitchell was born in Huntley, Scotland; was of quiet, modest manner, unostentatious in his charities, and will be greatly missed. A widow, a daughter and a son who have been associated with him in the business, survive him.

THE PRIVATE GARDENER.

Address by Robert Craig before the Massachusetts Horticultural Society, February 29, 1908.

I use the term "Private Gardener" because it is one in common use and well understood to distinguish one who has charge of a garden or grounds and cultivates vegetables, plants and flowers, not to sell, but for the use of those who employ him to do this work. The gardener assists and directs nature in producing everything which grows out of the ground for man's use; for the gratification of his palate, and which is capable of administering to his sense of beauty. His work is to provide not only food for the body but also "Food for the Soul." We sometimes see an advertisement in the daily papers like this—"Wanted, a gardener who understands care of horses," or "who can milk." Such an advertisement is a sad abuse of the word; what is wanted is a handy laborer, or man of all work; much that I shall say today cannot specially be applied to him.

The Private Gardener's Part in the Future of Horticulture.

I know that my audience includes many that are not gardeners, but I feel that they, in their interest in the subject, will pardon me if the greater part of my remarks are directed specially to gardeners. I choose the subject because I conceive that it is one of more importance than is generally assigned to it and that the private gardener is likely to play a part of continually growing importance in American life. His influence on the future of Horticulture is powerful for good or for evil. If he be a capable, energetic and honest man, he will do such work as will make his employer a patron of gardening, and if he be ignorant, careless and dishonest he will not only ruin himself, but will damage the cause he misrepresents. Allow me to recite a couple of instances occurring in my own neighborhood which illustrate this point:—

I was well acquainted with a wealthy gentleman who built new greenhouses and started to improve the grounds surrounding his fine mansion. He was fortunate in securing a fine English gardener, newly arrived in this country; his place rapidly improved under the new gardener's care and after two years' work, when the owner saw he was getting good results, he became greatly interested, and invested freely large sums to carry on the improvements and enrich the grounds with plantings of rare and beautiful trees and shrubs; he built additional greenhouses, bought many plants, and also a fine collection of orchids. Everything prospered and was a source of great pleasure to the owner and his friends, when suddenly the good gardener was stricken with an incurable disease and had to give up work. The place was then put in charge of his first assistant, a young man about 26 years old who was given a fine opportunity to make a name for himself, but he could not stand, even a little prosperity; took to drinking and playing the races, and during a spree in which he did not put in an appearance for two days, an accident to the boilers resulted in the entire stock of plants being frozen to death. The owner, who had plenty of

money to spend in gratifying his tastes, lost all interest in gardening and became a liberal patron of other fine arts. His collection of paintings and examples of fine sculpture are known far and wide, but the greenhouses are empty, the garden neglected, and it is not likely the owner's interest in these will ever be revived.

Faithfulness Is Rewarded.

Another instance coming under my immediate observation interested me still more:—One of the wealthiest men in the neighborhood of Philadelphia, retiring from active business, built one of the finest mansions in the State, employed the highest talent in landscape gardening and with a large force of men, in a couple of years had the new place greatly improved. He employed a young German gardener who had previously at a salary of only \$60 per month made a good name for himself; gave him entire charge and he worked with such intelligence, industry and honesty, that the employer built for him additional ranges of glass about two years ago at a cost of fifty thousand dollars, and allows him to spend annually a large sum in improving the place. Only last summer he took a trip to Europe at his employer's expense with power to purchase such rare plants as he might select. His salary is now quite satisfactory to him. Oh! but you say, this was a rare case; perhaps it was, but I am sure at the rate wealth is increasing in this country the number of such places will steadily increase. I like to quote Lord Bacon on this point:—"When ages grow to civility and elegance men come to build stately, sooner than to garden finely, as if gardening were the greater perfection."

Boston Gardeners' Good Record.

Before proceeding further it may be well for us to consider that we are in Boston; Boston a city rich in horticultural history, has always been foremost in encouragement of advanced gardening. Here in 1829 the Massachusetts Horticultural Society was incorporated "For the purpose of encouraging and improving the science and practice of Horticulture." Ever since, and before that time, Boston has been the foremost American city in Horticulture. In 1822 the first gardening periodical, The New England Farmer and Horticultural Journal was founded; followed by Hovey's American Garden and Barretts' Horticultural Register in 1835; the first greenhouse in the country, history says, was built in Boston by Andrew Faneuel about the beginning of the 18th Century. And today in the excellence of its parks and private gardens, in proportion to its population it is easily in the front. Those who love gardening in any branch, find in Boston a congenial atmosphere; Boston has been the home and scene of the life work of many famous gardeners. I look upon Jackson Dawson as the best all around propagator and plantsman that America has known, and the late Fred. L. Harris, for nearly half a century at Hunnewell's famous place at Wellesley, was a model for private gardeners to imitate.

Preparing Himself for His Life Work.

The problem of how a gardener should set about preparing him-

self for his life work is, in this country, a serious one. In the older countries of Europe, opportunities to acquire a thorough knowledge of all departments are plentiful. There are so many estates on which the grounds are admirably planned and planted, and where there are numerous houses adapted for propagating and growing everything for the garden; cold pits and cold houses; intermediate houses and "stove" houses, with graperies, fruit houses and hot beds, so that a man may get a thorough knowledge of gardening in all branches; and there are many commercial places which carry on all lines and where boys may go and learn the business as they grow to manhood. There are only a very few such commercial places in America. In this country almost all the trade establishments cultivate specialties as roses, carnations or palms. Nearly all of our good all around gardeners get their training abroad, and it is well for any young man who can get a chance to learn gardening under such a man, either on a large private place or in a park, some of which in the larger cities I am glad to say, have now large ranges of glass and grow everything but vegetables, which is a very important branch and of which I may have a few words to say later. Some of our colleges have now facilities for teaching gardening. I wish that all of the colleges would follow the example of Cornell, where they have six greenhouses in which students may gain a practical knowledge of plant growth, learn how to prepare soil and manure, and have opportunity to gain a general knowledge of advanced gardening. Many of the colleges have now a course in forestry, and I understand that young men getting diplomas, if otherwise fitted, can readily procure employment at fair salaries. It seems to me that the time is now ripe for all the leading colleges to build ranges of glass and have courses in practical Horticulture. Graduates from these classes, and otherwise desirable, would have an advantage over uneducated men in securing the best positions. The recent establishment of classes in landscape gardening by the Gardeners' and Florists' Club of Boston, is of great advantage to those near enough to take advantage, and is an example for all similar institutions everywhere to imitate.

Some Good Books.

To the gardener who wants to improve himself, books are a paramount necessity. The recorded wisdom of the ages is at your services here. Nicholson's Dictionary of Gardening and Bailey's Cyclopaedia of American Horticulture should be in the possession of every gardener; they describe nearly every plant in cultivation and their cultural notes are of very great value. I will not attempt naming all the good books but cannot refrain from mentioning Jenkin's Art of Propagation and Improvement of Cultivated Plants; Professor Taft's Greenhouse Construction; Hunt's How to Grow Cut Flowers; Henderson's Practical Floriculture; Falconer's Mushroom and How to Grow Them; Elwanger and Reynold's Gardening for Profit; Mrs. Van Rensselaer's Art Out of Doors; The Principles of the Har-



CHOICE SINGLE FLOWERING ENGLISH WALL-FLOWER FOR EASTER BLOOMING

We have an elegant lot of these old-fashioned favorites, field-grown plants, which were potted up into four-inch pots during the latter part of September and which have been carried through the winter in cold frames and are now in prime condition to move. If placed in a carnation house temperature they will come in nicely for Easter, at which time there will be ready sale, at remunerative prices.

Strong, bushy, shapely plants from four-inch pots, \$1.25 per dozen; \$8.00 per 100; \$70.00 per 1000.

HENRY A. DREER, 714 Chestnut St., Philadelphia, Pa.

mony and Contrast of Colors by M. R. Chevreul; Herrington and Smith on *Chrysanthemums*.

Cultivate a love for books; it is a habit that grows by indulgence; as the fondness for books grows you can add to your library; all the larger seed houses now carry the best of the horticultural books which you are privileged to look over and select according to your needs or taste. Subscribe for one or more of the trade papers and get your names on the lists of the Agricultural Stations so as to get up-to-date information; the results of the latest experiments along all lines. The seedsmen's catalogues are great educational factors; I know of no greater improvement horticulturally than in the character and contents of these valuable publications. A gardener should study natural landscapes so as to readily apprehend their points of beauty and their beauty as a whole, and then with "The art that doth mend nature" put the finishing touches thereto.

Have a Hobby.

Every garden may be made more interesting by excelling in some specialty; every gardener should have a hobby. If the place be a small one and your opportunity meagre, take in the flower line, pansies, verbenas or Phlox Drummondii or the herbaceous phlox and in the greenhouse plants either cyclamen, cineraria, primula, etc. By saving your own seed, carefully selecting, year after year, the finest, it is astonishing how you can improve the varieties in any species. Like results follow a similar course in vegetables. Buy, for instance, the finest varieties of corn and select from these for seed the ears that contain the greatest average of good points, as flavor, size and good appearance and you are likely to get corn better than you can buy. Or if your place and opportunity are greater start for instance making a collection of conifers; in groups or in single specimens; or a collection of rhododendrons or lilacs, of which there are now so many fine kinds; or roses, or paeonies, or similar plants in the hardy garden. You will find in a few years your constant and careful pursuit of your hobby will

result in making you and the place you represent, more or less famous, and your application to work along a special line will enable you to give valuable points to your fellows. As Emerson says "If you make shoes better than anyone else you will find a path beaten to your cottage door."

Raising New Varieties.

It is profoundly interesting to study how new varieties come. Nature works, often we know not how, in bringing forth new varieties, the influence of heredity undoubtedly prevails to some extent and instances are not wanting to show that it does. Let me give you just one in my own experience,—three years ago we made a number of crosses in carnations using the variety Harlowarden as one of the parents; you will recollect that this sort had a very long, very desirable stem and we noticed that about one-fifth of these seedlings had this Harlowarden stem, but there were characteristics developed in a number of seedlings which had no visible connection with either of the parents. Sometimes however the influence of both parents can be distinctly traced. Time will allow me to mention only one or two instances:—Many of you will recollect the introduction of the "Daybreak" carnation, a charming variety which had not many stems, but these were long and stiff and every shoot produced a flower. About the same time was introduced "Tidal Wave" which produced many stems but lacking in length; the crossing of these two varieties produced the famous "Lawson" which inherited the good points of both varieties. Among the seedlings with Lawson blood has been found Enchantress which I think has more good qualities than any other variety and following along this line has resulted in producing a free blooming vigorous type which has made Mr. Fisher famous. The results of Mr. Walsh's work in roses of the Wichuraiana type are little short of marvellous; the man who does such things is a public benefactor. But, while man can do something in breeding from types, nature is always at work and often produces, we know not how, valuable "breaks" in seedlings or

sports, which are frequently lost because the gardener fails to recognize their merits and propagate and perpetuate them. Private gardeners have done much in the past to preserve and propagate good new things and should be ever on the alert to take advantage of any opportunities along this line which kind nature may afford. The famous Seckel pear was a "chance" seedling found growing along the roadside and man had no hand in its origin, but some one should receive the blessings of generations for preserving and propagating it.

Forcing Vegetables.

One of the main branches of work for the private gardener is the growing of vegetables. Our enterprising seedsmen are continually introducing new varieties and a large percentage of these novelties have merit and occasionally there is a great advance over previous varieties. Be ever on the alert for the good new things.

There should be an abundance of vegetables for spring, summer and fall and where the facilities exist, in the winter also. George Elliott says: "No man can be wise on an empty stomach" and Ben Jonson that "A good dinner lubricates business." No dinner is complete without fresh vegetables and many of the very finest, most luscious and delicately flavored cannot be purchased in the markets, because they do not pay to grow commercially. If you can furnish your employer a regular supply of these dainties, you will find yourself in close touch with him and he is likely to help you in any of your plans. Vegetables grown under glass are superior to those grown out-doors, in tenderness, crispness and fine flavor and every large garden should have special houses or ranges of houses for this purpose; these need not be expensive structures and may be in any out-of-the-way place so as not to interfere with the architectural effect of the plant structures; connected with these vegetable houses there could be other inexpensive houses where seedlings could be started, dormant plants kept and much of the repotting and unsightly work done, thus giving opportunity to keep the show houses more attractive.

Notice to Florists

THE FRUIT AUCTION COMPANY, New York City, beginning at an early date this Spring, will inaugurate daily auction sales at wholesale of plants, etc. Exceptional facilities provided in our new building, centrally located at 200, 202 and 204 Franklin Street (corner Washington Street).

Date of initial sale will be announced in next issue of this paper.

For terms and all other detailed information, address:—

THE FRUIT AUCTION CO.,

P. O. Box 640 - - NEW YORK CITY

Correspondence and personal interviews cordially invited. *Payments will be made to sellers of plants the day following sale.* The movement to sell plants by auction at wholesale has the support and commendation of leading growers and importers.

Importance of Industry.

Now, a few words on the importance of industry. From the very earliest times, the great men have extolled the value of industry. "Go to the ant thou sluggard, consider her ways, and be wise" has served for the text of many a powerful sermon; the expression that "Genius in only an infinite capacity for work" has been endorsed by many thinkers. Napoleon said "I have never found the limit of my capacity for work." In short, the men who have made their mark in the world have been at a loss for words to express themselves strongly enough on the subject. Don't be afraid of work and don't forget that "Folks who never do more than they are paid for, never get paid for more than they do." Let not the amount of pay be your main consideration; rather see how much and how well you can do the work; the real reward that life holds out for work is the increased capacity to do more and better work, and consequently greater satisfaction and enjoyment. The man who wants an indolent life is not fitted for a gardener. Many good men fail to do their best for want of courage and faith in themselves, and from lack of energy and ambition; there are not so many failures from want of capacity. Herrick says:—"The great man is not so great as folks think, nor the stupid man so stupid as he seems."

The late Peter Henderson, a great gardener, close observer and successful business man often said that he did not think there was so much difference in the mental capacity of men as in their courage, ambition and industry.

Have faith in yourselves and loyalty to your employer. I am fond of the saying of Fra Elbertus "If pnt to the point, an ounce of loyalty is worth a pound of cleverness." Don't be afraid to undertake all the time bigger things; your ability will grow in your earnest attempts to accomplish; and, don't be afraid of manual labor if occasion require; it will not lessen, but increase your mental power; a stiffening and strengthening of the spinal column begets no weakness of the mind; "A sound mind in a sound body." The immortal Lincoln split rails, and it was only recreation for Gladstone to cut down immense trees with an axe. The advantage of outdoor exercise is recognized everywhere. The orator in the English Parliament exclaimed "the Battlefields of England were won on the cricket fields of Eton;" there was as much force in the rejoinder of the Irish Member, "They were won on the bogs of Ireland."

Better Greenhouses.

One of the most encouraging points in gardening is the improvement in greenhouse architecture since the days of small glass and heating by brick flues. Many of the more ambitious structures of early date were failures for practical purposes; architecturally effective, they were frequently poorly heated and otherwise defective from a cultural standpoint; thanks to frequent consultations in recent years between architects and advanced gardeners, the more modern houses have gained in appearance and are almost perfect in producing results.

The problem of compensation for gardeners is an interesting one; most gardeners think it is a poorly paid work and perhaps it is, considering how much has to be learned. I think, however, the money reward rests largely with the individual; there can be nothing like a uniform scale of wages. I had, for instance, paid my foreman about twelve hundred dollars a year, but I must say that one to whom I paid two thousand dollars per annum was the most profitable one to me. I think, on the whole, the outlook for first-class gardeners is good. Never in the history of nations has wealth increased so fast as in the United States during the past quarter of a century, and a majority of the wealthy men will, in the future, I venture to say, find their highest pleasure in developing their gardens and country estates.

On the fine old estates in England, France and Germany, no one is more respected, nor in closer, kindlier touch with the owner than the head gardener. As fast as men fit themselves in character, deportment and ability, this is coming to pass here; but, admitting that salaries might in some cases be justly increased, we must not forget that gardening has many advantages for those who are fond of it: it is the most healthful of all occupations; it is one of the fine arts. Ruskin has defined Fine Art as any in which the head, hand and heart work together. I cannot see why the gardener cannot take as much pleasure as the owner. "He who admires is the real possessor." "There is no ancient gentlemen, but gardeners."

**Wholesale
Only**

Recent Genuine Novelties in

SWEET PEAS

The following are our recent introductions in the **Giant Flowered Wavy Standard Varieties**. These have all been sent out well fixed in character, and can easily be kept so:—

GLADYS UNWIN—Lovely pale pink. A great market favorite.

NORA UNWIN—The purest and finest giant flowered white.

PHYLLIS UNWIN—A deep rosy carmine self, and sunproof.

A. J. COOK—Best described as a giant flowered Mrs. Walter Wright.

FRANK DOLBY—Lovely pale blue, a giant flowered Lady Grisel Hamilton.

MRS. ALFRED WATKINS—A lovely delicate pale pink with pale salmon shading.

E. J. CASTLE—Rich carmine with salmon shading. The finest of all for artificial light.

These are all the Giant Flowered Offsprings of "Gladys Unwin."

ALSO **EVELYN BYATT**—Rich flame color. The first of this rich color.

To be had from all Seedsmen and Nurserymen throughout the United Kingdom, America and the Colonies.

WHOLESALE ONLY FROM

WATKINS & SIMPSON.

Wholesale Seed Merchants
and Growers,

12, Tavistock St., Covent Garden, LONDON, W. C., England

CARNATION EXHIBITION AT CORNELL.

The Horticultural Department of Cornell University held its fourth annual carnation exhibit on March 4th-6th. The exhibit was in charge of the students in floriculture, who managed, staged and judged the blooms. The exhibition was purely for educational purposes and no prizes were offered. However, many growers took advantage of the opportunity to place their stock before interested students.

The exhibition was well advertised about the city and many visitors were present during the three days. After the exhibition the blooms were put to good use by the students, in packing demonstrations, design making, etc. At the weekly meeting of the Horticultural Club (Lazy Club), carnations was the subject of discussion. An interesting talk on carnation breeding was given by Dr. Weber, and the varieties from a commercial point of view were discussed by L. D. Batchelor.

Among the exhibitors were C. W. Ward, whose two winners at the Washington show, Mrs. C. W. Ward and Alma Ward, caused a great deal of comment and expressions of admiration from the visitors. His President and Beacon also showed excellent growing. R. Witterstaetter exhibited Afterglow; Chicago Carnation Company, Andrew Carnegie; F. R. Pierson Co.,—Variegated Lawson, Enchantress, Winsor, Beacon, and Red Lawson; the Horticultural Department of New Hampshire College.—an interesting lot

of seedlings with their pedigree attached; John E. Haines,—Pink Imperial, Variegated Imperial, John E. Haines, White Perfection, and Light Pink Seedling No. 102; Paul Thomson, the yellow variety Neptune; James D. Cockcroft,—Harvard; Frank H. Kimberley,—Enchantress and White Enchantress, also the violet Mary Louise; Horticultural Department of Cornell,—Harlowarden and Mrs. Thos. W. Lawson.

FIRE RECORD.

Weaver & Miller, McAlister, Okla., lost about \$4,000 in a fire which destroyed their potting shed and boiler room on February 22.

John Hass, Thomaston, Conn., who had recently enlarged his plant and put in a new heating system, lost his entire stock on March 3 through an overheated furnace.

The gardener's cottage and a large poultry house on the estate of William E. Walker, at Manchester-by-the-Sea, Mass., were destroyed by fire on March 10, causing a loss estimated at about \$7000. The blaze started from an overheated oil lamp in the brooder.

The office and heating plant of the Norwood Floral Co., Pawtuxet avenue, Norwood, R. I., were completely destroyed by fire on March 3. Loss on building is about \$1,000; the loss on stock is not estimated. Two houses that were saved were left without heating apparatus.

March 4, one of the large barns belonging to the Park Board of Minne-

apolis went up in flames. Inventory values of contents was \$16,500; barn was valued at \$10,000; insurance on barn, \$6,750; and on contents, \$9,750. Among the largest loss was 150 row-boats, one gasoline launch, seven street sprinklers, all the gymnasium and play apparatus for the different parks and 40 tons of hay. No damage was done to the greenhouses nor to the other large barn, which contains the machine and carpenter shops, tool storage room and stables.

PUBLICATIONS RECEIVED.

Twenty-fifth Annual Report of the Board of Park Commissioners, Minneapolis, Minn. This report is a work of art in itself. The typographical work, views and maps are very fine, and the autograph of Theodore Wirth on the various beautiful landscape diagrams and plans is a sufficient guarantee of their high quality. Minneapolis is liberal with her appropriations for park acquisition and maintenance, and this volume shows how well she is getting her money's worth.

Hardy Rhododendrons, Azaleas Conifers, Clematis, H. P. Roses, Shrubs and Herbaceous Plants from our HOLLAND NURSERIES

Prices Moderate

P. OUWERKERK, 246 Jane St., Weehawken Heights
P. O. No. 1, Hoboken, N. J.

BARGAINS in TREES and PLANTS

Six for 25c., delivered free by mail
List Free. D. J. TWOMEY, Dept. H., Geneva, N. Y.

Seed Trade

Retail seedsmen report peas as moving slowly thus far this season, and attribute this to the unsatisfactory prices received for this crop last season, and to the difficulty of getting them picked after the crop was grown. This latter complaint has become chronic, but unless there is a change in business conditions before the gardening season opens this spring this matter should no longer disturb the farmers' dreams.

While peas have moved slowly, there has been an active demand for beans, particularly of the green pod varieties, and more especially the Black Valentines. Without attracting attention this variety has disappeared from the market, and now can scarcely be bought at any price. Not only have the present supplies of these beans become exhausted, but stock seed is so scarce that growers are unable to accept orders tendered them for the 1908 crop. Of course the practical impossibility of securing this variety for this season's planting, will compel truckers to turn to others, such as the Red Valentine, Refugee and the Stringless Green Pods, and unless the fever for seed beans speedily subsides, reserves of the varieties named will be reduced to very small proportions when planting time is over. But what of another year? Perhaps it is well not to cross that bridge until we reach it.

Excepting counter trade which is not quite equal to last year—due entirely to the weather—seedsmen report business as excellent. Of course there are a few exceptions, as always to all rules, but, in general, seed business is good and this applies particularly to the mail order houses. A few days of warm weather will start counter trade into life, and the retail dealers will have their innings.

P. K. Nott, late with Josiah Young, of Troy, N. Y., is now with Peter Henderson & Co.

C. S. Stewart has taken a position with the National Seed Co., 117 Fifth Ave., Chicago.

C. Peterson & Sons, Escanaba, Mich., will add flower and vegetable seeds to their florist business.

Visitors in Philadelphia: Carl C. Cropp, Chicago; Chas. R. Kimberlin, Santa Clara, Cal.; W. C. Langbridge, Cambridge, N. Y.

James H. Cheyne who has been in the employ of Schlegel & Fottler Co., Boston, for some time, is leaving to take a position with E. L. Beard in landscape work.

Onion seed of the 1908 crop is offered at strong prices by the California growers. Reds at around \$1.25, White Portugal at \$1.25, yellows at around \$1.00 and White Globe at \$1.50 to \$1.75.

Joseph Bradley, for twenty years with Johnson & Stokes, and, since the dissolution of that firm, with the Johnson Seed Co., has resigned his

position, and is now with Henry F. Michell Co.

Wm. Elliott & Sons are to move about May 1st to Vesey street. This move is made necessary by the practical doubling of their rent. There has been an increase in rentals of from 50 to 100 per cent. in the vicinity of the tunnel stations in New York.

Mr. Charles Kimberlin, of Santa Clara, Cal., expects to finish his business in the east this week and leave for home. He seems to be the "last of the Mohicans." It is reported that Lester H. Morse will not send a representative east this season.

The counter trade in Toledo, O., has been very slow so far. All are up against the passage of a new State bill to have clover and grass seeds 98 per cent. pure, introduced by a man who thinks he knows it all, and as this city is the principal market for clover seed, Toledo dealers are hit more than seedsmen elsewhere.

WHOLESALE SEEDSMEN'S LEAGUE.

A special meeting of the Directors of the League, F. W. Bruggerhof presiding, was held 18th February, at which meeting there was passed the following resolutions:

"Recognizing the fact that the Seed Trade of America should have an established custom similar to that adopted by their kindred association, (The S. A. F.) we, the Board of Directors of The Wholesale Seedsmen's League, at a meeting held in New York, February 18, 1908, unanimously adopt the following motions:

"Resolved, That as the business of growing, selling and distributing seeds has become such an important pursuit, it now seems absolutely necessary that those of us having the interests of the business at heart should recommend our fellow seedsmen to respect the energies and progressive methods of each other; and it is further

"Resolved, That the originator, discoverer, or introducer of a new variety of seed, grain or plant has the sole right of naming said variety, and that this name should be the one under which this variety is to be known in the trade thereafter, and the name not altered except that it may be ordinal or firm, when used as a prefix or changed in any way until it is absolutely demonstrated by continued selection the variety has been so improved or changed as to warrant its being given a new name.

"Resolved, That where a Seedsmen spends time and money in search of new and distinct varieties of seeds, that it is

his right to name any variety he may discover which has merit and which has not heretofore been catalogued or offered by the American Seed Trade.

"Resolved, That we, the Board of Directors of The Wholesale Seedsmen's League, hereby express our strong disapproval of the practice that has occasionally obtained with some dealers of offering under new names such varieties of seeds, or plants, which should be known only under the names given to them by their introducers; which original names may be fairly considered as trademarks, and the property of the originator or introducer.

"Resolved, That we hereby pledge the influence and the support of The Wholesale Seedsmen's League to the end that, when introducers of newly discovered or improved varieties of seeds shall have disseminated the same under special names, they should be protected against unwarranted and unfair competition through the offering of these novelties by others under other names than those given to them by the originators or introducers.

"Resolved, That the Secretary of the League be instructed to take up this subject with The American Seed Trade Association, with a view to having said Association pass suitable resolutions at the next annual meeting in June, to the effect that every new variety of seeds, either vegetable, flower or grain, that may be introduced and catalogued hereafter by an American Seedsmen should be registered under its proper name, with a full description and source of origin, with the Secretary of either The Wholesale Seedsmen's League or The American Seed Trade Association, as may be decided upon after conference of Committees to be appointed by the Presidents of the two organizations, said Joint Committee being authorized to fix the amount of the nominal charge to be made to cover cost of such registration and attendant expenses. It is recommended that either said Joint Committee, or a Special Committee, be made a Standing Committee to consider all questions in dispute as to the naming of varieties, and if impossible to adjust same amicably between the disputants, to submit reports to the Board of Directors of both organizations.

"Resolved, That copies of these resolutions be sent to each member of The Wholesale Seedsmen's League, and that a sufficient number of copies be sent to the Secretary of The American Seed Trade Association for mailing to each member thereof.

"Such distribution of copies of these resolutions to be accompanied by an explanation from the Secretary that we seek the co-operation of all honorable houses, in the interests of all, in an earnest endeavor to fix firmly the usages of the American Seed Trade upon the highest plane of business ethics."

The Secretary was instructed to mail a copy of this action to all members of the League, and to other Seedsmen in close affiliation.

BURNET LANDRETH,
Secretary of the League.

MUSHROOM SPAWN

MICHELL'S ENGLISH BRAND

Our Spawn is used by the leading growers throughout the country on account of its Superior Quality.

Per 12 Bricks, \$1.40; per 100 Pounds, \$5.00; per 1000 Pounds, \$47.50

NOTE. Special Price For One Week Only.

Headquarters for LIL. FORMOSA. Stock Limited. Order Quick

WRITE FOR OUR WHOLESALE CATALOGUE

HENRY F. MICHELL CO., 1016 Market St., PHILADELPHIA, PA.

A NEW STRAWBERRY

We have been growing and selling Strawberry Plants in this town over THIRTY YEARS. We introduced Brandywine, Kittie Rice, Sen. Dunlap, Wm. Belt and others of value. Now we are bringing out

THE HIGHLAND

which we expect to take the lead as a Money-Maker. Let us tell you about it and forty others. It will cost you but a postal card.

M. CRAWFORD & CO., Box 1020, Cuyahoga Falls, Ohio

PLANT IMPORTS.

There were entered at the port of New York during the week of March 4th to March 10th inclusive, the following goods:

From Rotterdam: H. F. Darrow, 26 es. plants, 9 bls. do.; Elliott Nursery Co., 4 es. flower roots; Wm. Elliott & Sons, 20 es. plants; McHutchison & Co., 102 es. do., 4 bls. do., 6 es. flower roots; Maltus & Ware, 250 es. plants, 4 bls. do., 31 es. flower roots, 6 es. shrubs; P. Ouwerkerk, 168 es. trees; Orlando J. Smith, 39 bls. plants; C. B. Richard & Co., 27 es. do.; J. M. Thorburn & Co. 6 es. do.; Vaughan's Seed Store, 11 es. do.; To Order, 7 es. do.; Sundry Forwarders, 125 es. do., 4 es. flower roots.

From Antwerp: A. T. Boddington, 1 es. bulbs; Hussa & Co., 5 es. plants; Maltus & Ware, 2 es. do.; 1 es. bulbs; Vaughan's Seed Store, 4 es. bulbs; Sundry Forwarders, 3 bales trees, 12 pgs. do.

Via Havre: Peter Henderson & Co., 4 es. plants, 3 es. seed; O. G. Hempstead & Co., 5 es. plants; J. M. Thorburn & Co., 2 es. do.

Via Southampton: C. C. Abel & Co., 34 es. plants; H. F. Darrow, 35 es. do., 5 es. seed; McHutchison & Co., 4 es. plants; August Rolker & Sons, 23 es. do.; C. B. Richard & Co., 8 es. do.; Sundry Forwarders, 37 es. do., 1 es. trees.

From Copenhagen: Vaughan's Seed Store, 1 es. Seed.

CATALOGUES RECEIVED.

Harvey Seed Co., Buffalo, N. Y.—Annual Catalogue for 1908, of Vegetable, Field and Flower seeds. This is the fiftieth anniversary catalogue of this firm, which was founded in 1858. The book is almost unique in the fact that wood cuts instead of half tones are almost exclusively used in its illustration.

Altimo Culture Co., Caufield, Ohio.—Trade Price List of "Altimo Brand" Aster Seed. The asters shown by this company at the S. A. F. Convention in Philadelphia last season were very fine. This list describes some twenty-five varieties. It also gives full particulars concerning the offer of \$250.00 in prizes for competition during the coming season. Everyone interested in the improvement of the aster should procure a copy of this pamphlet.

WIBOLTT'S SNOWBALL CAULIFLOWER-SEED

No. 34 is the earliest of all Snowballs, the most compact, the surest header, is giving the largest and snow-whitest heads, and is the best keeper in dry-weather. Demand it through your seed-firm or direct from

R. WIBOLTT, NARSKOV, DENMARK



QUALITY SEED BULBS PLANTS

SEND FOR CATALOGUE.

ARTHUR T. BODDINGTON

348 West 14th St., New York.

Thorburn's Seeds

COLD STORAGE LILY OF THE VALLEY PIPS

COLD STORAGE LILIUM Harrisii, also SPIRAEA GLADSTONE, LILIUM Auratum, speciosum album, speciosum rubrum, Large Flowering Japan Iris, Cannas, etc.

For prices, state quantities required.

J. M. THORBURN & CO.
33 Barclay St., through to 38 Park Place
NEW YORK

BRIDGEMAN'S SEED WAREHOUSE
RICKARDS BROS.,
Props.

37 East 19th St., - NEW YORK CITY

BRASLAN SEED GROWERS CO.
GROWERS FOR THE
WHOLESALE TRADE ONLY
SAN JOSE, - - CALIFORNIA

Burpee's Seeds
PHILADELPHIA

Blue List of Wholesale Prices mailed only to those who plant for profit.

FISKE SEED CO.
can supply new, to the florist for immediate use.
Aster Seed A Specialty
Special Florist List Free

H. E. FISKE SEED CO.
12 & 13 Faneuil Hall Square. BOSTON, MASS.

JUST ARRIVED
LARGE SHIPMENT OF
High-Grade SCOTCH SOOT.

We have the stott Double Nozzle
THOMAS J. GREY CO.
32 & 33 So. Market St., BOSTON

Vegetable and Flower **SEEDS**

Reliable and Tested. Catalogue Mailed Free

WEBER & DON
Seed Merchants 114 CHAMBERS STREET
NEW YORK

BAMBOO CANES TOUGH AND STRONG
6 ft. long — \$1 per 100; \$6 per 1000; \$11 per 2000

They cost about 10 per cent. more than other kinds, and they are 10 times better.

STUMPP & WALTER CO., - 50 Barclay St., New York

Best Quality Fall Bulbs

It is to your advantage to place your order early. Send us a list of your wants and we will quote you rock-bottom prices. Copy of our Florists' Bulb Catalogue will be sent upon request. Catalogues now ready.

VICK'S SUPERB PANSY SEED

All the best varieties in separate colors

VICK'S SUPERB MIXTURE

the best strain from all the leading named sorts

1-8 oz. 75c. 1-4 oz. \$1.50 Ounce \$5.00

JAMES VICK'S SONS, Rochester, N. Y.

CYCLAMEN

Farquhar's Giant Strain

Unsurpassed for size of flowers.

Giant Crimson Giant Pink
Giant White Finest Mixed
Giant Excelsior, White with Claret Base

100 seeds, \$1.25; 1000 seeds, \$10.00.

R. & J. FARQUHAR & CO.
6 & 7 So. Market St., Boston, Mass.

Look through the Buyers' Directory and Ready Reference Guide. You will find some good offers there also.

RELIABLE SEEDS—Sow Now

Primula Obconica Grandiflora

new Hybrids as: Blood-red, Blue, Carmine, Pink, Purple, Violet, Pure-white, Compacta, Gigantea, Fringed Mixed Hybrids, each separate, Tr. Pkt. 50 cents, 6 Tr. Pkts \$2.50.

O. V. ZANGEN
Seedsman. HOBOKEN, N. J.

C. C. MORSE & CO.
Address all communications to our permanent address
48 to 56 Jackson St., San Francisco, Cal.

The Largest Seed Growers in the United States

BRECK'S SEEDS
For Farmer, Market Gardener and Florist
New Crop High Grade
Catalogues mailed free on application

Joseph Breck & Sons Corp.
47-54 NO. MARKET ST., BOSTON, MASS.

CAULIFLOWERS E E D
CABBAGE E E D

HJALMAR HARTMANN & CO.,
12 Stormgade,
COPENHAGEN, DENMARK.

EASTER PLANTS

**Azaleas, Baby Ramblers,
Hydrangeas, Lilies,
Geraniums**

In fine condition. Write for Prices

WM. W. EDGAR CO., Waverley, Mass.

Martial Bremond

WHOLESALE GROWER OF FRENCH BULBS

— OLLIOULES, FRANCE —

A superior quality supplied at market prices. Shipments made direct. Cases marked to order.

Sole Agents

RALPH M. WARD & COMPANY
12 West Broadway - - NEW YORK

BY WIRELESS FROM ROBERT CRAIG.

Mr. Craig would like to call special attention of the readers of HORTICULTURE to a few nice things in the plant line—some comparatively new, others not—which he can assure them are well deserving of general cultivation for commercial purposes. Phyllanthus nivosus, for instance, sometimes called the Snow-Bush, with its graceful sprays of white and green mottled foliage; what more striking combination can be imagined than this in association with poinsettias at holiday time? It is even more effective than its tri-colored variety rosea-picta, which is occasionally seen in a private conservatory. There is certainly a place for this subject either in plant form or cut, and it is also useful for summer bedding. It roots badly from cuttings but may be propagated readily from roots in the same manner as with bouvardias. Another desirable plant for the trade is Ficus Chauvieri. An old plant but still scarce. Its foliage is thick and more leathery even than pandurata, and it excels that popular novelty in its beautiful venation, resembling a framework of white ivory. People are beginning to recognize the beauty of veins and thorns. Taste in this direction hasn't been cultivated as it should. Ficus pandurata keeps best when potted, with a good mass of roots.

Dracaena Massangeana is far superior to Lindenii. The latter has the white variegation on the edge of the foliage and consequently its leaves are apt to decay, but Massangeana has the variegation in the centre and its solid green edge is an advantage. It makes an admirable hotel plant when it attains a height of from three to

four feet. Fritz Dressel, who is the best dracaena grower in the country, grows 2500 Massangeanas every year and sells them at \$2.00 apiece. He does this by keeping a permanent bed of stock plants and has done so for twelve years. Otherwise, as by importing little plants from Europe, it would be quite expensive to go into. Among the red-foliaged dracaenas, the new Mandaiana looms up as future leader. This is a cross between D. Youngii and terminalis; it gets its bright color from the latter and its sturdy growth from the former. Rose Tausendschon is likely to take a high place on and after the coming Easter. Crimson Rambler valuable as it has been, is on the wane, and people are looking for pink, now. Among the hybrid perennials Magna Charta still remains the best for Easter forcing. More than any other variety it can be controlled and brought in just when wanted to a day.

Bear in mind when planning for holiday stock for next season that Begonia Agathe compacta is very compact and floriferous and better for use as small plants in hampers than the popular Lorraine. It has been established beyond doubt that Lonsdale's variety (light-pink Lorraine) stands the best of all the Lorraines under store or dwelling house conditions.

By breeding for early bloom cyclamens with great masses of flowers may be had for Christmas. Each grower should select his seed with this in view. Think of cyclamens with forty open flowers on them! The people will take every one that is offered at Christmas. A good addition to the Christmas azaleas is Princess Victoria. It is a soft, pure pink, and very compact and floriferous. In the red-flowered Christmas azaleas Apollo Schultz takes the lead. It is a better flower and a better color than the old Apollo, being a vermilion scarlet.

Last Christmas we noticed that the brighter the color was the better it suited the buyers. Aucuba and ardisia are still the best of the bright-berried plants. Aucubas will retain their berries and foliage in any room and don't seem to object to any temperature, hot or cold. A light top-dressing of blood, say two months before Christmas, makes dark green foliage and increased color in fruit. A light application is better than a heavy one. Too heavy a dressing is liable to cause the foliage to drop. For palms, ferns, ficuses and all such things this

is beneficial; you can see the effect in ten days.

Marantas, as a rule, are unsatisfactory plants for florists' use, but the pretty little rosea lineata is all right and will keep well in mixed baskets, hampers, etc.

We are waiting for Rhododendron Pink Pearl to get cheaper. It will be a great acquisition to the forcing list as soon as the price gets within our reach.

Altimo Culture Co.

WHOLESALE
GROWERS OF CUT FLOWERS
CANFIELD, OHIO

NEPHROLEPIS SCOTTII

in the following sizes, extra good value

25c., 50c., 75c., and \$1

Grand Specimen Plants at \$3, \$4, \$5, \$6.

JOHN SCOTT

Rutland Road and E. 45th St.
Tel. 2890 Bedford BROOKLYN, N. Y.

NEP. WHITMANI

2 1/4 in., \$5.00 per 100

NEP. WHITMANI

3 1/2 in., \$25.00 per 100

BOSTON FERNS

2 1/4 in., \$3.00 per 100

H. H. BARROWS & SON Whitman, Mass.

FERNS

Boston, 4 inch 12c, 5 inch 25c.

Pierstonii, 3 inch 8c.

Elegantissima, 2 1/4 inch 6c, 3 inch 10c,
4 inch, 15c.

BAUR FLORAL CO., Erie, Pa.

COLD STORAGE MULTIFLORUM LILY BULBS

7 to 9s

Deliver very immediate or as Ordered. \$45 per 1000

WOOD MOSS, 65c per b'dle.

O. RUSCONI, 128 W. 6th Street, Cincinnati, O.

Hardy Roses

American Grown—Superior to Imported

We have unsold at the present time the following varieties—all field grown plants, grown in our nurseries at Rochester, N. Y.:

Anne de Diesbach	Prinze Camille
Chlo	Erich Brunner
Frau Karl Druschki	Crimson Rambler
General Jacquemont	White Rambler
John Hopper	Yellow Rambler
Mme. G. Lutzet	Philadelphia Rambler
Marshall P. Wilder	Common Sweet Brier
Mrs. John Lalng	Mme. G. Brunt
Paul Neyron	Wichuriana (The Type)

These plants are in our storage cellars and can be shipped at any time. Prices on request.

ELLWANGER & BARRY

Nurserymen—Horticulterists

Mount Hope Nurseries, Rochester, N. Y.

JAPANESE
THE YOKOHAMA NURSERY CO.
31 BARCLAY STR. NEW YORK.
LILIES
PLANTS
BAMBOO STAKES

ORCHIDS

If you contemplate investing money in Orchids this season we respectfully solicit your orders. Our stock is larger and finer than ever before and the prices are the lowest consistent with good stock. **WE HANDLE ORCHIDS EXCLUSIVELY**, and are in a position to furnish these cheaper and better than anyone else in the business.

Great quantities of *Cattleya Mossiæ* are now in sheath. *C. Gaskelliana* and *C. gigas* are making splendid flowering shoots to bloom this season. **The first crop of flowers will pay you for the plants.**

If you are looking for other things we have them, such as *Cypripediums*, *Dendrobiums*, *Oncidium*s, *Vandas*, etc., etc.; also choice and rare plants in great numbers at low prices, of imported stock. **Vanda coerulea has just arrived.** Central and So. American plants will commence to arrive after all risk of frost is over, or from beginning of May.

We have imported and shipped Orchids for the last twelve years and we believe we know something about the business. If the plants arrive in poor shape you would never get them for we would not give you cause for complaint.

We also have on hand supplies such as fine Orchid-peat, Live Sphagnum Moss, Leaf Soil, Hand-Made Orchid Baskets, Books on Orchids, etc. Before ordering write us for prices.

LAGER & HURRELL,

ORCHID GROWERS
AND IMPORTERS

SUMMIT, N. J.

ORCHIDS

We wish to inform our many patrons that we shall receive in about two weeks' time fine importations of

D. Wardianum, *D. formosum giganteum*, *D. Phalaenopsis*.
IN APRIL:—*C. Trianae*, *C. Mendelii*, *C. labiata*, *C. gigas*, *C. Warnerii*,
C. Harrisoniæ, *C. granulosa*, *C. guttata Leopoldii*, *C. citrina*,
Oncidium varicosum.
IN MAY:—*C. Mossiæ*, *C. Gaskelliana*, *C. Percivalliana*, *C. Schroderæ*,
Vanda coerulea.

A trial order will prove we carry **THE BEST STOCK THAT CAN BE SECURED.** Write for price list

CARRILLO & BALDWIN, - - SECAUCUS, N. J.

ORCHIDS

We are at present booking orders for freshly imported Orchids for delivery 1908, of all leading kinds at reduced prices. We have just received the following:—*Oncidium Sarcodes*, *O. Forbesii*, *O. Tigrinum* and *Sophranites*, *Grandiflora* and *Coccinea*.

LAGER & HURRELL, Summit, N. J.

ORCHIDS for Spring Delivery

NEW IMPORTATIONS

Cattleyas, *Laelias* *Oncidium*s, etc.

WRITE FOR PRICES

Now is the time to Pot Orchids. Best Quality of Peat, Moss and Baskets on hand.

JOSEPH A. MANDA, 191 Valley Road, WEST ORANGE, N. J.

ORCHIDS

Largest Importers, Exporters, Growers and Hybridists in the World

Sander, St. Albans, England
and 235 Broadway, Room 1
NEW YORK CITY

Imported Orchids

JUST TO HAND

Laelia Purpurata
Cattleya Intermedia
Cattleya Mossiæ

JULIUS ROEHRS CO.,

The Orchid Nurseries RUTHERFORD, N. J.

ORCHIDS

We shall receive in about two weeks' time fine importation of *Dendrobium Wardianum*, *D. Phalaenopsis*, *D. Formosum giganteum*.

April: Most all the *Cattleyas*, *Vandas*, *Oncidium*s, e. c. Write for Price List.

GARRILLO & BALDWIN, Secaucus, N. J.

ORCHIDS

The largest importation of Orchids ever received in this country **WILL ARRIVE** next spring from Brazil, Colombia and Venezuela. If you intend putting in stock wait for these to arrive and we will quote the Lowest Prices in America.

ORDONEZ BROS., - Madison, N. J.

In writing to Advertisers kindly mention Horticulture

JOHN BREITMEYER'S SONS

Cor. Miami and Gratiot Aves.
DETROIT, MICH.

Artistic Designs . . .
High Grade Cut Blooms

We cover all Michigan points and good
sections of Ohio, Indiana and Canada

William J. Smyth FLORIST

Cor. Michigan Ave. and 31st St., CHICAGO

We ship to all points in Illinois and Iowa.

Phones: Douglas 744, Douglas 523, Douglas 740

M. C. and J. E. HAUSWIRTH

232 Michigan Ave.

CHICAGO

AUDITORIUM ANNEX Tel. Harrison 585

SAMUEL MURRAY Florist

Coates House Conservatory
1017 BROADWAY, KANSAS CITY, MO
Both 'Phones 2670 Main

FRED C. WEBER FLORIST

4326-28 ST. LOUIS, MO.
OLIVE STREET

Established 1873
Long Distance Phone Bell Lindell 676



WASHINGTON,
D. C.

GUDE'S

Geo. H. Cooke FLORIST

Connecticut Avenue and L Street
WASHINGTON, D. C.

The Park Floral Co.

J. A. VALENTINE
Pres.

DENVER, COLORADO

WILLIAM L. ROCK FLOWER CO.

KANSAS CITY, MO.

will carefully execute orders for Kansas City
and any town in Missouri or Kansas.

Of Interest to Retail Florists

Orchids and gardenias continue in the ascendancy with the prospect of a long run.

One of the hustling florists of the State of Pennsylvania is John A. Kepner of Harrisburg, who, besides a large range of greenhouses, runs three retail flower stores.

The improvement in flower production, the development of taste, the changes in fashions, the exigencies of competition, all affect the prosperity and have a vital bearing upon the business of the florist. His success will go forward or backward in direct proportion to his foresight and grasp of the situation as conditions shift and new problems come up from day to day. In no line of business is it more unqualifiedly true than in the florist business that "to stand still is to go backward."

A marked change in the fashion of corsage bouquets has manifested itself within the past three years. The single or California violet is striving hard for the mastery, and while the old favorite, Marie Louise, is doomed to bend the knee to her more graceful sister, it is also true that neither is finding favor for outdoor use. The over-production of the double variety made it a too common commodity, bringing the flowers within the reach of masses and much to the disturbance of the classes.

Never have the requirements as to character, ability and refined manners in the florists' store clerk been so exacting as now. The demand for young men possessing these qualifications has been and is far in excess of the supply. More than half the flower stores of the fashionable sections of the large cities have room for the ideal salesman,—one who can attract and develop business by his knowledge, industry, address and artistic ability—and for such the question of salary is easily settled.

"Follow your leader" is CHICAGO the custom here. Some time ago a prominent down-town florist began advertising in the daily paper, now several stores advertise special sales for Saturday. It seems to pay as we notice that large lots of stock are bought and disposed of by these firms. A West Side florist who uses his window to display features of holidays and other special events from time to time, "did himself proud" this season on the occasions of Washington's birthday and St. Valentine's day. This is a kind of advertising that always pays.

LEADING RETAIL FLORISTS—
Index by Towns will be found in
Buyers' Directory.

Florists Out of Town

Taking orders for delivery in
New York or Vicinity
can have them filled in best
manner and specially deliv-
ered by

Thomas Young, Jr.

500 F. 5th Ave., New York City
Telephone 847 Bryant.

ALEX. McCONNELL

571 FIFTH AVENUE
NEW YORK CITY

Telegraphic orders forwarded to any part of the United States, Canada, and all principal cities of Europe. Orders transferred or intrusted by the trade to our selection for delivery on steamships or elsewhere receive special attention.

Telephone Calls, 487 and 488 38th St.
Cable Address, ALEXCONNELL

WILLIAM H. DONOHOE

FLORAL DECORATOR

17 East 28th St., New York

Special Attention to Theatre
and Steamer Orders, and reliable
deliveries guaranteed.

DAVID CLARKE'S SONS

Deliver orders from any part of the country to
New York City

Or OUT-GOING STEAMERS

Write or telegraph

2139-2141 Broadway, New York
Telephone 1552-1553 Columbus

M. A. BOWE

In the Heart of New York City

1294 Broadway

NEW YORK

Tel. 2270, 38th St

Our Motto -- The Golden Rule.

YOUNG & NUGENT

42 West 28 St., NEW YORK

"FLOWERS BY TELEGRAPH"

Flower Deliveries

In Brooklyn and other Long Island Points
New York City, New Jersey, etc. At Theatres,
Hotels, Steamers or Residences.

WILSON

Fulton St. and Greene Ave., Brooklyn, N. Y.

ALBANY, N. Y.

EYRES

Flowers or Design Work

DELIVERED IN ALBANY AND VICINITY
ON TELEGRAPHIC ORDER.

11 NORTH PEARL ST., ALBANY, N. Y.

JACOB SCHULZ, 644 Fourth Ave.,
LOUISVILLE, KY.

Cut Flowers of BEST QUALITY in season
delivered promptly to any address.

Write, Telegraph or Telephone.
Cumberland and Home Phones 223 and 984

NEW RETAIL FLOWER STORES.

Hanft Bros., who have for many years located at the corner of 58th street and Madison avenue, New York City, have removed to a new and spacious store on the southwest corner of 62d street and Madison avenue.

BUSINESS CHANGES.

Thomas Cogger, florist of Rochester, N. Y., is now located at 280 E. Main St.

The California Nursery Co. has purchased the O'Neil Nursery at Haywards, Calif.

Joseph Haworth of Yonkers, N. Y., has purchased the greenhouses of Mrs. Hugh Chesney, Farmington, Conn., and will continue the business.

You will find something worth reading on every page of HORTICULTURE.

PROMPT DELIVERY IN BOSTON

AND ALL NEW ENGLAND POINTS
HOUGHTON & CLARK
396 Boylston St., Boston, Mass.



BOSTON'S BEST
In Quality and Design

Can be relied upon when you transfer your retail orders to

EDWARD MACMULKIN
194 Boylston Street, Boston

Send flower orders for delivery in
BOSTON

and all
NEW ENGLAND POINTS
THOS. F. GALVIN
124 Tremont St., Boston

TRANSFER

Your orders for flower or plant delivery in Eastern New England to

JULIUS A. ZINN,
2 Beacon St., Boston.

Fine Design Work a Specialty.

YALE Orders for flower deliveries to Yale College and all other Connecticut points carefully filled and delivered by

J. N. CHAMPION & COMPANY
1026 CHAPEL STREET NEW HAVEN, CONN.

ATLANTA FLORAL CO.
41 Peachtree Street, ATLANTA GEORGIA.

HART'S HANDY HANDLE

"At Easter-time, with a little chiffon decoration, and the Handle, we were able to increase the value of plants from 50% to 100%."—H. E. WILSON.

Write for descriptive circular and prices

GEO. B. HART, 24 Stone St., Rochester, N. Y.

PERSONAL.

Visitors in Chicago: Hugo Will and R. A. Latham, of Minneapolis, Minn.

Mr. and Mrs. Philip Breitmeyer of Detroit are enjoying a short trip to Florida.

Bernard Kelly has severed his connection with the Hobart Greenhouses, Bridgewater, Mass.

The 70th birthday of William K. Harris, the veteran Philadelphia plantsman, was appropriately celebrated by a dinner at the Cafe Peran on the 10th inst. The affair was informal but gave many of his old friends an opportunity to offer congratulations.

John Hayes, of the Munn Estate, Orange, N. J., met with an accident last Friday, his head coming in contact with the iron rod of the ventilator, to the damage of his head. While not able to be out, yet in last accounts he was doing as well as could be expected.

Visitors in Boston: Frank L. Moore & Son, Chatham, N. J., Mr. and Mrs. C. H. Emerson, Newmarket, N. H., Jas. McHutchison and C. B. Knickman, New York, Albert Pochelon of L. Bemb Floral Co., Detroit. Charles Schwake, New York, Wm. Jurgens, Newport, R. I., J. N. Champion, New Haven, Conn.

NEWS NOTES.

Mrs. C. H. Foreman, Louisiana, Mo., will carry on her late husband's business.

Chas. Morton, manager of the Redondo Floral Co. at Los Angeles, Calif., was previously located in Chicago.

Plant auction sales will commence in Boston on March 31, when N. F. McCarthy will open the spring campaign with a big consignment of trees and hardy shrubbery, at his salesrooms, 84 Hawley street.

Carnation Claribel, to be disseminated in 1910 by the Wellsville Cut Flower Company, is described as a fiery scarlet overlaid with a velvety crimson sheen. It is the result of a cross between Estelle and Maceo and is in its prime at Christmas.

Mr. H. Suzuki, who is exceptionally well-informed on lily culture, says that bulbs grown in cool countries, while they make a denser crown and shorter stem, continue longer in good health

than those from warmer climates. The latter cannot be relied on to be free from the encroachment of disease for more than ten years.

It is rumored that an association of New York growers—the prime movers of which are some carnation men of Long Island—is projected with the intention of marketing their own products. A meeting, to be held in New York city this week, has been called, and rose and violet growers have been invited to attend also.

SAVE

your weekly copies of this paper.

DON'T

throw them away.

The contents are always of PERMANENT VALUE and you may need them for reference tomorrow, a year from tomorrow, or still later.

BOSTON FLORIST LETTER CO.
Manufacturers of FLORISTS' LETTERS

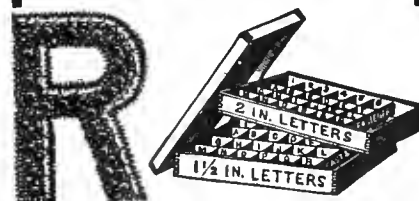

This wooden box nicely stained and varnished, 18x30x12, made in two sections, one for each size letter, given away with first order of 500 letters

Block Letters, 1 1/2 or 2 inch size per 100, \$2.
Script Letters, 3. Fastener with each letter or word. Used by leading florists everywhere and for sale by all wholesale florists and supply dealers

N. F. MCCARTHY, Manager
66 Pearl Street, BOSTON, MASS.

In ordering goods please add "I saw it in HORTICULTURE."

The "Japana" Cut Flower Holder

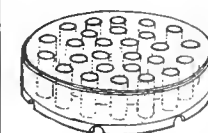

A handy article for florists. Sells to the trade on sight. Made of glass in three sizes. The "Anglais" Table Decoration, something entirely new, long needed. The florist and housewife will appreciate this article, as it simplifies the art of table decorating.

Ask for catalog.

M. V. CARNSEY, Dept. M,
130 Waiola Ave., La Grange, Ill.

KORAL SCRIPT LETTERS AND EMBLEMS

ONCE USED ALWAYS USED
Forsale by all first class supply houses. Made by
KORAL MFG. CO.
26 Hawley St., Boston

American Beauty Roses
 Orders in any quantity promptly filled. All grades.
Acacia pubescens
 Sprays of this popular golden spring beauty in regular daily shipments, \$1.50 and \$2.00 per bunch.

The Leo Niessen Company
 1209 Arch St., Philadelphia, Pa.
 Open from 7 a. m. to 8 p. m.

CHOICE SPRAYS OF PLUMOSUS and SPRENGERI
 50c. per bunch
CHOICE VALLEY WHITE VIOLETS
 \$3.00 per 100 \$1.50 per 100

S. S. PENNOCK - MEEHAN CO.
 1608-1620 Ludlow St. PHILADELPHIA
 "The" Wholesale Florists of Philadelphia

EVERYTHING SEASONABLE IN
CUT FLOWERS
EDWARD REID, Wholesale Florist
 1526 Ranstead St., PHILADELPHIA
 STORE CLOSES 8 P. M.

CHAS. W. MCKELLAR
 51 WABASH AVE., CHICAGO
 Western Headquarters for Choice Orchids
 Valley, Roses and all Cut Flowers

PETER REINBERG
 WHOLESALE
CUT FLOWERS
 51 Wabash Av., Chicago, Ill.
 In writing advertisers, mention Horticulture

CUT FLOWER BOXES
EDWARDS FOLDING BOX CO
 MANUFACTURERS
 PHILADELPHIA, PA.

AMERICAN BEAUTY and all other ROSES
LILY OF THE VALLEY, CARNATIONS
WELCH BROS., 226 Devonshire St., Boston, Mass.

AMERICAN BEAUTIES
 Fancy BRIDES and MAIDS
W. E. MCKISSICK WHOLESALE FLORIST
 PHILADELPHIA
 1619-1621 RANSTEAD ST.

DAILY CONSIGNMENTS
 From 40 to 60 Growers
 We can care for your outflower wants to advantage.
E. F. WINTERSON CO.
 45-47-49 WABASH AVE., CHICAGO

Rice Brothers
 115 N. 6th Street, MINNEAPOLIS, MINN.
WHOLESALE FLORISTS and SUPPLIES
 CUT FLOWERS received twice daily, and can fill your orders to your satisfaction. A complete line of Hardy Greens—WILD SMILAX, BOXWOOD, HARDY FANCY FERNS, GALAN LEAVES.
 Write for quotations on large quantities.

WHOLESALE FLOWER MARKETS—TRADE PRICES—Per 100 TO DEALERS ONLY

	CHICAGO March 10	TWIN CITIES March 9	PHILA. March 9	BOSTON March 12
ROSES				
Am Beauty, Fancy and Special...	30.00 to 50.00	45.00 to 60.00	35.00 to 40.00	25.00 to 35.00
" Exua.....	15.00 to 25.00	30.00 to 40.00	20.00 to 25.00	15.00 to 20.00
" No. 1.....	10.00 to 12.00	20.00 to 30.00	12.50 to 15.00	8.00 to 10.00
" Lower grades.....	3.00 to 8.00	10.00 to 20.00	3.00 to 6.00	4.00 to 6.00
Bride, "Maid, Fancy & Special....	6.00 to 8.00	8.00 to 11.00	10.00 to 12.00	6.00 to 8.00
" Extra and No. 1....	4.00 to 6.00	6.00 to 8.00	6.00 to 8.00	3.00 to 5.00
" Lower grades.....	2.00 to 4.00	4.00 to 6.00	3.00 to 5.00	1.00 to 2.00
Killarney, Richmond, Fan & Sp...	6.00 to 8.00	8.00 to 11.00	15.00 to 20.00	8.00 to 10.00
" Lower grades.....	2.00 to 4.00	3.00 to 7.00	4.00 to 8.00	2.00 to 6.00
Chat'nay, Wellesley, Fan & Sp...	6.00 to 8.00	8.00 to 11.00	12.00 to 15.00	4.00 to 8.00
" Lower grades.....	2.00 to 4.00	3.00 to 7.00	4.00 to 10.00	1.00 to 3.00
Golden Gate, Ivory.....	4.00 to 8.00	5.00 to 8.00	5.00 to 10.00	1.00 to 6.00
CARNATIONS				
Fancy and Novelties.....	1.50 to 3.00	3.00 to 4.00	3.00 to 4.00	1.00 to 2.00
Ordinary.....	.50 to 1.00	1.50 to 3.00	1.00 to 2.00	.50 to .75
MISCELLANEOUS				
Violets.....	.40 to .50	.50 to 1.00	.60 to .75	.25 to .50
Cattleyas.....	50.00 to 60.00 to 50.00	50.00 to 60.00	50.00 to 60.00
Cypripediums.....	8.00 to 15.00	12.00 to 15.00	12.50 to 15.00	8.00 to 10.00
Lilies.....	10.00 to 15.00	10.00 to 15.00	12.50 to 15.00	8.00 to 10.00
Lily of the Valley.....	2.00 to 4.00	2.00 to 3.50	2.00 to 3.00	2.00 to 3.00
Freesias.....	2.00 to 3.00	1.50 to 3.00	2.00 to 3.00	1.00 to 2.00
Rom n Hy., Paper White Nar.....	1.50 to 4.00	2.00 to 3.50	2.00 to 3.00	1.00 to 2.00
Daffodils.....	1.50 to 4.00 to 2.50	2.00 to 3.00	1.00 to 2.00
Tulips.....	1.50 to 4.00 to 2.50	2.00 to 3.00	1.00 to 2.00
Mignonette.....	2.00 to 6.00	4.00 to 8.00	3.00 to 4.00	3.00 to 4.00
Gardenias.....	20.00 to 40.00	35.00 to 50.00	25.00 to 40.00	25.00 to 40.00
Lilac per bunch.....	.75 to 2.00 to 1.50	.50 to 1.00	1.00 to 1.50
Sweet Peas.....	.50 to 1.00 to 1.00	.50 to 1.00	.50 to 1.00
Adiantum.....	.50 to 1.00	.75 to 1.00	1.00 to 1.25	1.00 to 1.50
Whitmanii Fronds..... to 15.00 to 15.00	3.00 to 5.00	2.00 to 3.00
Smilax.....	10.00 to 15.00	12.00 to 15.00	15.00 to 20.00	10.00 to 12.00
Asparagus Plumosus, striggs.....	35.00 to 50.00	35.00 to 50.00	35.00 to 50.00	25.00 to 50.00
" " & Spreng (too heavy)	25.00 to 50.00	35.00 to 50.00	3.00 to 60.00	1.00 to 50.00

THE FLORISTS' SUPPLY HOUSE OF AMERICA

Without a rival in knowledge of the requirements of the trade and the ability to supply them. Our New Illustrated Catalogue, recognized as a work of art unprecedented in its line for variety, novelty and completeness, tells the story fully, and if you have not yet sent for it, do so now.

'TIS FREE TO EVERYBODY IN THE TRADE

H. BAYERSDORFER & CO., 1129 Arch St., Philadelphia, Pa.

FLOWER MARKET REPORTS

The general outlook in **BOSTON** the flower trade has not changed, and there is little prospect that it will until Easter. Relief from the heavy production and local stagnation is hoped for by that time, at least. It is a common saying that there is nothing one can ask for that cannot be supplied, yet we saw one party chasing in all directions today for a bunch of yellow antirrhinums and he did not find them, although this market is better supplied with "odds and ends" than any other. Anemones, ranunculuses, antirrhinums, coreopsis, calendulas, schizanthus, Liliun speciosum rubrum, etc., are all in evidence at present time.

Stock of all kinds was **BUFFALO** rather plentiful the past week, especially carnations, which filled up the coolers to overflowing, and while fair prices have been holding on, the market could stand the strain no longer, and on Friday and Saturday bargain signs were seen galore among the retailers. It was a genuine bargain day for the public and helped to clean up a little surplus at the wholesalers. Tea roses and Beauties are in good supply, as well as lily of the valley, gardenias, violets, peas and all bulbous stock and lilies, which need some force to move.

Business for the past **CHICAGO** week was fairly good with the wholesalers. Although prices were very low a great quantity of stock was handled. At no time during the season have New York violets been here in greater quantity, but they were sold, and although at figures as low as twenty cents per hundred, yet one could not but wonder where they all went to. Carnations are about in the same predicament at this time. Quantities of southern jonquils are being shipped here, depreciating the price of home-grown flowers. Lilies are more plentiful, also smilax. Hardy ferns are beginning to show the effects of long storage, but it is not expected that they will reach the prices of a year ago, when they brought \$6.00 per thousand. American Beauties are still scarce, but a crop is on the way for Easter.

With a seemingly un-**DETROIT** limited supply of carnations and bulbous flowers the bottom has dropped out of the heretofore healthy market conditions. Azaleas, rhododendrons and lilac plants are used a great deal for large floral design work while wreaths of assorted bulbous flowers not only provide for an agreeable change but give the florist an opportunity to create very artistic effects.

A lessening of the de-**NEW YORK** mand for cut flowers is more apparent this week, but as a consequence of the continued dull condition which has prevailed throughout the season it has not been attended by the general depression of prices usual when the Lenten season sets in. Roses grow more

plentiful and the call for them is anything but urgent and prices are gradually weakening; Beauties particularly move slowly, the price now being about half and less than the quotations of three weeks ago. Carnations hold their own and the heavy cut shows some signs of diminishing for a time at least. They have been so cheap that it does not seem that they can suffer a further decline. Violets, with few exceptions, can be disposed of only to the street pedlers. All bulbous stock is in greater supply than the demand can take care of at—for the grower—living prices. Some southern bulb stock has already made its appearance. The supply of green stuff is about equal with the demand.

American Beauty **PHILADELPHIA** roses are more plentiful this week and prices have dropped a little. Richmond and Liberty have improved in quality with larger receipts and a sagging in quotations. Some improvement in Killarney is noticeable in spots and there is no doubt of its increasing popularity over Bridesmaid. The carnation market is still very much overcrowded. Cattleyas are good with sufficient supply. Cypripediums are plentiful but demand meagre. The violet situation is tolerable. Violets seem more affected by the weather than any other crop when it comes to distribution. Lily of the valley is still in poor demand. Very little change to report on other staples, except that supplies have slackened up a little. Gardenias are fairly plentiful. The greens mark it is not quite so good as it has been.

The Twin Cities **TWIN CITIES** report that business is keeping up good. Violets and bulbous stock are still plenty, while roses are in short supply. Carnations went up some this last week.

The Lenten season **WASHINGTON** is upon us, as is also a glutted market. All flowers of fine quality are in abundance, but good green still remains very scarce and high accordingly. The weather still continues unsettled and unfavorable to the sellers.

TOLEDO NOTES.

Business here has been rather quiet of late, perhaps more on account of the exceptional cold weather, and also the river flood and ice gorge. J. Fischer's boiler room was two feet under water for several days, and one hour with carnations planted in solid beds had enough water in to flood the carnations 18 inches. Fortunately the weather was warm enough to prevent the frost from getting into the houses. We all feel very sorry for Mr. Fischer and hope that his loss will not be too great.

O. B. Wisner closed his city store on March 6th and will give his entire attention to his store connected with his greenhouses.

A DAILY PLANT AUCTION.

As announced in our advertising columns, The Fruit Auction Company of New York is about to inaugurate a series of daily auction sales of plants and other horticultural material open exclusively to the trade. This innovation will be watched with great interest and, if it meets with general support, will vitally affect the wholesale plant trade of the metropoljls. Our old friend J. P. Cleary will wield the hammer and no doubt will have a large gathering of the craft in attendance when he makes his opening address.

The Virginian crop of bulb flowers is well advanced and should we be favored with a few warm days shipping will commence about the 25th. As a larger quantity than usual were planted last fall heavy consignments may be expected this season.

E. A. BEAVEN
Southern Wild Smilax,
Log Mosses,
 Natural and Perpetuated — at Wholesale,
EVERGREEN, ALABAMA.

H. J. Smith
HARDY CUT FERN
DEALER, ETC.,
 Write for Prices

HINSDALE, MASS.

Alex Mann, Jr. Co. Inc.
 Wholesale Dealer in
Florists' Supplies and Cut Flowers
 White Doves, \$9.00 per doz.
 Galax Leaves.
 1125 Polk Street, San Francisco, Cal.

J. B. Murdoch & Co.
 Wholesale Florists
FLORISTS' SUPPLIES
 714 Penn Ave., PITTSBURG, PA.
 Long Distance Phone 1435 Court.

J. KOPELMAN & CO.
 Wholesale Dealers in
Cut Flowers and Florists' Supplies
EVERGREEN AND FERN LEAVES
 OF ALL KINDS.
 21 Washington St., PROVIDENCE, R. I.
 Telephone Connection.

ROBERT J. DYSART,
Public Accountant and Auditor
 Simple methods of correct accounting especially adapted for florists' use.
Books Balanced and Adjusted
 Merchants Bank Building
28 STATE ST., BOSTON
 Telephone, Main 58

The KERVAN CO. 113 W. 28th St. New York
WHOLESALE DEALERS
 Fresh cut Palmetto & Cycas Palm Leaves, Galax, Leucothoe, Ferns and Mosses. All Decorating Evergreen

JOHN YOUNG
WHOLESALE FLORIST
 Finest American Beauties and
 Carnations
51 West 28 St. - NEW YORK

FORD BROTHERS
 48 West 28th Street, NEW YORK
FINE ROSES FANCY CARNATIONS
 A Full Line of All CUT FLOWERS
 Telephone. 3870 or 3871 Madison Square

H. E. FROMENT,
 Wholesale Commission Florist,
 Choice Cut Flowers,
 57 West 28th St., :: NEW YORK.
 Telephones: 2200, 2201, Madison Square.

The Reliable Commission House
 Richmond Roses and Rich Flowers
 of all varieties
JOS. S. FENRICH
 110 W. 28th Street, New York
 Tel. 324-325 Madison Square

Established 1891 BUY FROM SHIP TO TRY
ALFRED H. LANGJAHR
 All Choice Cut Flowers in Season
 55 West 28th St., New York
 Telephone 3924 Madison Square.

JOHN I. RAYNOR
Wholesale Commission Florist SELLING AGENT FOR LARGEST GROWERS
 A full line of Choice Cut Flower stock for all purposes. Comprises every variety grown for New York market, at current prices
 TEL. 1998 MADISON SQUARE 49 W. 28 St., New York City

Walter F. Sheridan
 Wholesale Commission Dealer in
CHOICE CUT FLOWERS
 39 West 28th Street, New York
 Telephone: 3532-3533 Madison Square

HEADQUARTERS FOR NOVELTIES
ORCHIDS A SPECIALTY
 THE HIGHEST GRADE OF **VALLEY** ALWAYS ON HAND
 GARDENIAS, DAISIES, ROSES AND CARNATIONS
 Telephone
JAMES McMANUS, 759 Mad. Sq. 42 W. 28th St., New York

PHILIP F. KESSLER 55 & 57 W. 26th St., New York City
 Commission Dealer, Wholesale Buyer and Seller of
GUT FLOWERS
 Open from 5 a. m. to 6 p. m. Sunday till 10 a. m.
 Tel., 5243 and 2921 Madison Sq. Res., 345 J., Newtown.
Finest Lilies in the Market Every Day in the Year.

WHOLESALE COMMISSION FLORIST **J. K. ALLEN** 106 W. 28 ST. NEW YORK
 Telephone 167 Madison Sq.
 OPEN 6 A.M. DAILY
 We have a good regular outlet for seasonable flowers

NEW YORK QUOTATIONS PER 100—TO DEALERS ONLY

	Last Half of Week ending Mar. 7 1908	First Half of Week beginning Mar. 9 1908	Last Half of Week ending Mar. 7 1908	First Half of Week beginning Mar. 9 1908
Roses				
Am. Beauty, fan and sp.	10.00 to 25.00	10.00 to 25.00	40.00 to 50.00	40.00 to 50.00
" extra	5.00 to 12.00	5.00 to 12.00	8.00 to 10.00	8.00 to 10.00
" No. 1	3.00 to 5.00	3.00 to 5.00	8.00 to 10.00	8.00 to 10.00
" Lower grades to 1.00 to 1.00	1.00 to 2.00	1.00 to 2.00
Bride, 'Mald, fan and sp.	4.00 to 8.00	4.00 to 8.00	1.00 to 1.50	1.00 to 1.50
" extra	2.00 to 3.00	2.00 to 3.00	1.00 to 1.00	1.00 to 1.00
" lwr. grds. to 1.00 to 1.00	1.00 to 2.00	1.00 to 2.00
Killarney, Richmond, fancy & spec	6.00 to 10.00	6.00 to 10.00	2.00 to 4.00	2.00 to 4.00
" lower grades	2.00 to 4.00	2.00 to 4.00	1.00 to 6.00	1.00 to 6.00
Chatenay, Wellesley, fan. and spec.	6.00 to 8.00	6.00 to 8.00 to .75 to .75
" lower grades	1.00 to 4.00	1.00 to 4.00	.50 to .60	.50 to .60
Golden Gate, Ivory	1.00 to 6.00	1.00 to 6.00	.75 to 1.50	.75 to 1.50
Carnations, Fancy and Novelties.	1.00 to 2.00	1.00 to 2.00	8.00 to 12.00	8.00 to 12.00
" Ordinary	.50 to .75	.50 to .75	25.00 to 35.00	25.00 to 35.00
Violets	.25 to .30	.20 to .30 to 10.00 to 10.00
Cattleyas				
Cypripediums				
Lilies				
Lily of the Valley				
Freesia				
Roman Hy., Paper White Nar.				
Dafodils				
Tulips				
Mignonette				
Gardenias				
Lilac p r bunch				
Sweet Peas				
Adiantum				
Smlax				
Asparagus Plumosus, strings				
" " & Spren. (too bchs.)				

B. S. SLINN, Jr.
 —WHOLESALE FLORIST—
 55 & 57 W. 26th St., New York City
 Tel., 3864 Madison Sq. Shipping Orders Solicited.
VIOLETS Roses and Carnations

Edward C. Horan
 Wholesale Florist
 55 WEST 28th ST.
 Tel. 1462 1463 Madison Square New York

TRAENDLY & SCHENCK
WHOLESALE FLORISTS
 Furnish best stock at fair prices all the year round Send for quotations on fall orders
 Tel. 798.799 Madson Sq. 44 West 28th Street, New York City

Alexander J. Guttman
THE WHOLESALE FLORIST OF NEW YORK
 43 WEST 28th STREET
 PHONES. 1664--1665 MADISON SQUARE
ENOUGH SAID



HARDY CUT FERNS

Sphagnum Moss, Extra Large Bales, per bale, \$1.25. Fancy and Dagger Ferns our specialty. A trial order will convince you that we ship only first-class stock. Headquarters for Florists' supplies and wire work. All cut flowers in season. **BOXWOOD**, per bunch 35c, 50 lbs. \$7.50.

MICHIGAN CUT FLOWER EXCHANGE, INC., All 'phone connections 38-40 Broadway, Detroit, Mich.

FANCY and DAGGER
Extra fine, \$1.75 per 1000. Bronze and Green Galax, \$1.25 per 1000. Leucothea Sprays, \$1.00 per 100, \$7.50 per 1000.

Headquarters in Western New York
FOR
ROSES, CARNATIONS
And all kinds of Seasonable Flowers
Wm. F. Kasting Co.
Wholesale Commission Florist, also Dealer in -
Florists' Supplies and Wire Dealings.
383-87 ELLICOTT ST.
BUFFALO, N. Y.
Give us a trial. We can please you.

FRANK S. HICKS & CO.
Wholesale Florists.
Open Now for Consignments of Cut Flowers.
52 West 28th Street, - New York City
Tel. 2920 Mad. Sq.

FRANK MILLANG
Wholesale Florist
Telegraphic Orders Filled and Delivered.
55-57 West 26th St., New York City.

Best Flowers
IN THE
BOSTON MARKET
BOXWOOD, \$17.50 per cwt.
BRONZE and GREEN GALAX, \$7.50
per 10,000.
BEST HARDY FERNS, \$1.50 per 1000
N. F. McCarthy & Co.
84 Hawley St., BOSTON, MASS.
Largest Dealers in Supplies in New England.

HENRY M. ROBINSON & CO.
Wholesale and Commission
FLORISTS
Hardy Cut Evergreens and Florists' Supplies
15 Province St. and 9 Chapman Place,
BOSTON, MASS.

SAMUEL A. WOODROW
WHOLESALE PLANTSMAN
Palms, Large and Small Ferns, etc.
53 West 30th Street, NEW YORK
Telephone 2083 Madison

WILLIAM H. KUEBLER
Brooklyn's Foremost and Best
WHOLESALE COMMISSION HOUSE
A First Class Market for all CUT FLOWERS
28 Willoughby St., Brooklyn, N. Y.
Tel. 4591 Main

GLEARY'S HORTICULTURAL CO.
Management AMBROSE T. GLEARY
Wholesale Contracting, Jobbing, Auction
HORTICULTURAL PRODUCTS
of every description.
Consignments Received. Surplus Stock Converted.
62 Vesey St., NEW YORK

Moore, Hentz & Nash,
Wholesale Commission Florists,
55 and 57 West 26th Street,
Telephone No. 756
Madison Square, New York.

WHOLESALE FLOWER MARKETS. — PER 100. TO DEALERS ONLY.

	CINCINNATI March 10	DETROIT March 10	BUFFALO March 9	PITTSBURG March 9
ROSES				
Am. Beauty, Fac. and Sp. to	20.00 to 35.00	30.00 to 50.00	40.00 to 50.00
“ Extra	25.00 to 30.00	15.00 to 20.00	13.00 to 30.00	20.00 to 30.00
“ No. 1	10.00 to 15.00	10.00 to 15.00	10.00 to 15.00	10.00 to 15.00
“ Lower grades	5.00 to 6.00	4.00 to 5.00	5.00 to 10.00	4.00 to 6.00
Bride, 'Maid, F. & S. to	8.00 to 10.00	10.00 to 12.00
“ Extra	6.00 to 8.00	6.00 to 8.00	6.00 to 8.00
“ Low. gr.	3.00 to 5.00	4.00 to 6.00	4.00 to 6.00 to 4.00
Killarney, Richmond, Fan. & Sp.	6.00 to 8.00	8.00 to 10.00 to 10.00	10.00 to 12.00
“ Lower grades	4.00 to 6.00	4.00 to 6.00 to 6.00	6.00 to 8.00
Chatenay, Wellesley, Fac. & Sp.	4.00 to 8.00	8.00 to 10.00 to 15.00	8.00 to 10.00
“ Lower grades	4.00 to 6.00	4.00 to 6.00	7.00 to 10.00	4.00 to 6.00
Golden Gate, Ivory.	5.00 to 6.00	4.00 to 6.00	3.00 to 8.00	4.00 to 8.00
CARNATIONS				
Fancy and Novelties to 3.00	1.50 to 2.00	3.00 to 4.00	2.00 to 3.00
Ordinary	1.00 to 2.00	1.00 to 1.50	1.50 to 2.00	.75 to 1.50
MISCELLANEOUS				
Violets	50 to .75	.50 to 1.00	.40 to .75	.25 to .50
Catleyas	40.00 to 50.00	35.00 to 50.00	40.00 to 60.00 to 75.00
Cypripediums	12.00 to 15.00	12.00 to 15.00	10.00 to 15.00 to
Lilies	10.00 to 12.50	12.50 to 15.00	4.00 to 15.00	8.00 to 12.00
Lily of the Valley	3.00 to 4.00	3.00 to 4.50	2.00 to 4.00	3.00 to 4.00
Freesia to	1.00 to 3.00	1.00 to 3.00
Roman Hy., Paper White Nar.	2.00 to 3.00	2.00 to 3.00	2.00 to 3.00	1.00 to 2.00
Daffodils	2.00 to 3.00	3.00 to 4.00	2.00 to 3.00	2.00 to 3.00
Tulips	2.00 to 4.00	3.00 to 4.00	2.00 to 3.00	2.00 to 4.00
Mignonette	6.00 to 8.00	4.00 to 8.00	2.00 to 5.00	2.00 to 4.00
Ga denias	35.00 to 50.00	35.00 to 50.00	25.00 to 40.00 to
Lil c p r nouch to 1.50 to 1.50	.50 to 1.00 to 1.00
Sweet Peas	.50 to 1.00	1.00 to 1.50	.40 to 1.00	.25 to 1.00
Adiantum to 1.00	1.50 to 2.50	.50 to 1.00	.75 to 1.25
Whitmaoii Fronds to to	8.00 to 10.00 to
Smilax to 12.00 to 15.00 to 15.00	12.50 to 15.00
Asparagus Plumosus, strings	40.00 to 50.00	50.00 to	40.00 to 60.00	35.00 to 50.00
“ & Spren (100 bchs.)	20.00 to 35.00	50.00 to	25.00 to 50.00	40.00 to 50.00

H. G. BERNING
Wholesale Florist
1402 Pine Street, ST. LOUIS, MO.

A. MOLTZ
Will purchase flowers on order in N. Y. market and ship carefully at prevailing wholesale prices. Address
155-57 West 26th Street, New York City

MILLANG BROS.
WHOLESALE COMMISSION FLORISTS
41 West 28th Street
Telephones 3860 3861 Madison NEW YORK

REED & KELLER
122 West 25th St., New York
Florists' Supplies
We manufacture all our
Metal Designs, Baskets, Wire Work & Novelty
and are dealers in
Glassware Decorative Greens and Florists' Requisites.

In writing to Advertisers kindly mention Horticulture

Buyer's Directory and Ready Reference Guide

Advertisements under this head, one cent a word. Initials count as words.

Regular advertisers in this issue are also listed under this classification without charge. Reference to List of Advertisers will indicate the respective pages.

Buyers failing to find what they want in this list will confer a favor by writing us and we will try to put them in communication with reliable dealers.

ACCOUNTANT

R. J. Dysart, 28 State St., Boston.
For page see List of Advertisers.

ALTERNANTHERAS

Red Alternantheras at 40 cents per 100.
C. W. Moeckel, 17 Summer St., Fitchburg, Mass.

ARAUCARIAS

Godfrey Aschmann, 1012 Ontario St., Philadelphia, Pa.
For page see List of Advertisers.

ASPARAGUS

A. N. Pierson, Cromwell, Conn.
Asparagus Plumosus Seedlings.
For page see List of Advertisers.
Asparagus Plumosa, 2 in. pots. Fine plants, \$3.00 per 100; \$25.00 per 1000. Cash with order or good reference. Erie Floral Co., Erie, Pa.; or, Wm. F. Kastling Co., 385 Elliott St., Buffalo, N. Y.

ASTERS.

Charles A. Kibbe, Elmhurst, Ill.
Aster Lady Roosevelt.
For page see List of Advertisers.

AUCTION SALES

Cleary's Horticultural Co., 62 Vesey St., New York.
Horticultural Products of Every Description.
For page see List of Advertisers.
Wm. Elliott & Sons, 201 Fulton St., New York.
Plant Auction Sales.

AZALEAS

A. Leuthy & Co., Perkins St. Nurseries, Roslindale, Mass.
For page see List of Advertisers.
W. W. Edgar Co., Waverley, Mass.
For page see List of Advertisers.
August Rolker & Sons, New York, 31 Barclay St., or P. O. Box 752.
For page see List of Advertisers.

BAMBOO CANES

Stump & Walter Co., 50 Barclay St., New York.
For page see List of Advertisers.
Yokohama Nursery Co., 31 Barclay Street, New York.
For page see List of Advertisers.
Schlegel & Fottler Co., 26-27 So. Market St., Boston, Mass.

BAY TREES.

Bay Trees and Box Trees, standards and pyramids. All sizes. Price list on application. J. Roebers Co., Rutherford, N. J.

BEDDING PLANTS

R. Vincent, Jr., & Sons Co., White Marsh, Maryland.
For page see List of Advertisers.
Carlman Ribsam, 31 Wall St., Trenton, N. J.
For page see List of Advertisers.

BOILERS

BOILERS. "Burnham" Boilers made for greenhouse heating. Lord & Burnham, 1133 Broadway, N. Y.

BOXWOOD

Henry M. Robinson & Co., 15 Provlace St., Boston.
For page see List of Advertisers.
N. F. McCarthy & Co., 84 Hawley St., Boston, Mass.
For page see List of Advertisers.

BUILDING MATERIAL

BUILDING MATERIAL of all description for All Cypress, Semi-Iron, Iron Frame or Truss Houses. Hot Bed Sash and Frames. Lord & Burnham Co., 1133 Broadway, N. Y.

BULBS AND TUBERS

Joseph Breck & Sons, 47-54 N. Market St., Boston.
For page see List of Advertisers.
J. M. Thornburn & Co., 33 Barclay St., New York.
For page see List of Advertisers.
A. T. Boddington, 342 W. 14th St., N. Y.
For page see List of Advertisers.
Rickards Bros., 37 East 19th St., New York.
For page see List of Advertisers.
H. F. Mitchell Co., Philadelphia.
For page see List of Advertisers.
H. E. Fiske Seed Co., Faneuil Hall Sq., Boston.
For page see List of Advertisers.
James Vlek's Sons, Rochester, N. Y.
Fall Bulbs.
For page see List of Advertisers.
D. Rusconi, 128 W. Sixth St., Cincinnati, O.
Cold Storage.
For page see List of Advertisers.
Aug. Rolker & Sons, 31 Barclay St., New York.
Seasonable Import Plants and Bulbs.
For page see List of Advertisers.

K. Velthuys, Billegom, Holland,
Represented by Felix Bosch, 260 Clarendon St., Boston.
Bulbs French and Dutch.
For page see List of Advertisers.
Ralph M. Ward & Co., 2 W. Broadway, New York, Agts. for Martial Bremond, Orlonles, France.
French Bulbs.
For page see List of Advertisers.
Stump & Walter Co., 50 Barclay St., New York.
Canna Bulbs.
For page see List of Advertisers.
Yokohama Nursery Co., 31 Barclay St., New York.
Formosa Lilium Longiflorum.
Henry A. Dreer, 714 Chestnut St., Philadelphia.
Calla Elliottiana, Caladiums.

CANNAS

The Conard & Jones Co., West Grove, Pa.
For page see List of Advertisers.
A. T. Boddington, 342 W. 14th St., New York.
Henry A. Dreer, 714 Chestnut St., Philadelphia.
Good Robusta, dark-leaved, at \$1.50 per 100; large clumps Burbank, Mlle. Berat and Cimebar, at \$2.00 per 100; Pennsylvania, at \$2.50 per 100. C. W. Moeckel, 17 Summer St., Fitchburg, Mass.

CARNATIONS

P. Dorner & Sons Co., Lafayette, Ind.
For page see List of Advertisers.
S. S. Skidelsky, 1741 N. 18th St., Philadelphia.
For page see List of Advertisers.
Chicago Carnation Co., Joliet, Ill.
For page see List of Advertisers.
F. R. Pierson Co., Tarrytown, N. Y.
Winsor and White Enchantress Rooted Cuttings.
For page see List of Advertisers.
H. A. Jahn, New Bedford, Mass.
Carnation Lloyd.
For page see List of Advertisers.
John E. Haines, Bethlehem, Pa.
Carnations Imperial and Pink Imperial.
For page see List of Advertisers.

CARNATIONS—Continued

Chas. H. Totty, Madison, N. J.
For page see List of Advertisers.
A. N. Pierson, Cromwell, Conn.
For page see List of Advertisers.
The Leo Nlesson Co., 1209 Arch St., Philadelphia, Pa.
White Bros., Gasport, N. Y.
Winsor, White Enchantress.
Fair Maid Carnation cuttings, strong, \$1.60 per 100; 500 for \$7.50. C. W. Moeckel, 17 Summer St., Fitchburg, Mass.
Carnation cuttings of all the leading varieties at the same price as any reliable firm. Write for prices before you look elsewhere. Wm. F. Kastling Co., 385 Elliott St., Buffalo, N. Y.

CHRYSANTHEMUMS

Chas. H. Totty, Madison, N. J.
Single Chrysanthemums.
For page see List of Advertisers.
A. N. Pierson, Cromwell, Conn.
For page see List of Advertisers.
Elmer D. Smith & Co., Adrian, Mich.
Novelty Chrysanthemums.
Will have 100,000 rooted cuttings of the best 60 commercial varieties ready about March 25. Have your orders booked now. Postal will bring new price list. Satisfaction guaranteed. W. Ehmann, Corfu, N. Y.

CONIFERS

John Waterer & Sons, Ltd., American Nursery, Bagshot, Eng.
For page see List of Advertisers.

CUT FLOWER BOXES.

Edwards Folding Box Co., Philadelphia.
For page see List of Advertisers.
Folding cut flower boxes, the best made. Write for list. Holton & Hunkel Co., Milwaukee, Wis.

DAHLIAS

David Herbert & Son, Atco, N. J.
For page see List of Advertisers.
J. L. Moore, Northboro, Mass.
For page see List of Advertisers.
Henry A. Dreer, 714 Chestnut St., Philadelphia.
Dahlia Souvenir de Gustave Doazon.
15,000 Field-grown clumps 2c. and up. List ready. H. W. Koerner, Sta. B, Milwaukee, Wis.
Dahlia Roots—Undivided field clumps, Lynchurst, Maid of Kent, William Agnew, White Swan, Kreimhilde, John Walker, Arabella and A. D. Lironi. Write for low prices. Wood & Healey, Hamonton, New Jersey.
Cactus, Decorative, Show, Fancy and Pompon Dahlias. 75 leading varieties to select from. Strong divided clumps, in 10 or 20 varieties, my selection at \$3.00 per 100; \$25.00 per 1000. Single Dahlias, mixed, \$1.00 per 100. Cash with order please. Hermann Thiemann, Monson, Mass.

DECORATIVE PLANTS

A. Leuthy & Co., Perkins St. Nurseries, Roslindale, Mass.
For page see List of Advertisers.

EASTER PLANTS

Wm. W. Edgar Co., Waverley, Mass.
For page see List of Advertisers.
A. Leuthy & Co., Perkins St. Nurseries, Roslindale, Mass.
For page see List of Advertisers.

EUONYMUS RADICANS

Euonymus radicans, 1-1 1/2 ft., \$6.00; 2-2 1/2 ft., \$8.00 per 100. Bushy plants. Brae-Burn Nursery, West Newton, Mass.

For List of Advertisers See Page 352

EVERGREENS

The New England Nurseries, Bedford, Mass.
For page see List of Advertisers.

FERNS

A. Leuthy & Co., Roslindale, Mass.
For page see List of Advertisers.
H. H. Barrows & Son, Whitman, Mass.
Nephrolepis Whitman.
For page see List of Advertisers.
Godfrey Aschmann, 1012 Ontario St., Philadelphia, Pa.
For page see List of Advertisers.
John Scott, Brooklyn, N. Y.
For page see List of Advertisers.
Baur Floral Co., Erie, Pa.
For page see List of Advertisers.
Nephrolepis Exaltata Bostoniensis, fine young plants, \$10.00 per 1000.
N. Elegantissima, young plants \$15.00 per 1000. Send for price list. Soar Bros. Little River, Fla.

FERTILIZERS

Pulverized Manure Co., 31 Union Stock Yards, Chicago, Ill.
Wizard Brand Cattle Manure.
For page see List of Advertisers.
Thos. J. Grey & Co., 32 and 33 South Market St., Boston.
High-Grade Scotch Soot.
For page see List of Advertisers.
Schlegel & Pottler Co., 26-27 So. Market St., Boston, Mass.
Scotch Soot.

FLORAL PHOTOGRAPHS

Floral Photographs. Foley's 226-228 1-2 Bowery, New York.

FLORISTS' LETTERS.

Boston Florist Letter Co., 66 Pearl St., Boston, Mass.
For page see List of Advertisers.
Koral Mfg. Co., 26 Hawley St., Boston.
For page see List of Advertisers.

FLORISTS SUPPLIES

H. M. Robinson & Co., 15 Province St. and 9 Chapman Pl., Boston, Mass.
For page see List of Advertisers.
The Kervan Co., 113 W. 28th St., N. Y.
Decorative Evergreens.
For page see List of Advertisers.
Reed & Keller, 122 W. 25th St., New York.
For page see List of Advertisers.
J. B. Muddoch & Co., 714 Penn Ave., Pittsburg, Pa.
For page see List of Advertisers.
H. Bayersdorfer & Co., 1129 Arch St., Philadelphia.
For page see List of Advertisers.
Alex. Mann, Jr., Co., 1125 Polk St., San Francisco, Calif.
For page see List of Advertisers.

FLOWERS BY TELEGRAPH

Park Floral Co., Denver, Colo.
For page see List of Advertisers.
J. N. Champion & Co., 1026 Chapel St., New Haven, Conn.
For page see List of Advertisers.
George H. Cooke, Washington, D. C.
For page see List of Advertisers.
Gude Bros. Co., 1214 F St., Washington, D. C.
For page see List of Advertisers.
Atlanta Floral Co., Atlanta, Ga.
For page see List of Advertisers.
M. C. & J. E. Hauswirth, 232 Michigan Ave., Chicago.
For page see List of Advertisers.
William J. Smyth, Michigan Ave. and 31st St., Chicago.
For page see List of Advertisers.
Jacob Schulz, 644 4th Ave., Louisville, Ky.
For page see List of Advertisers.
Thos. F. Galvin, 124 Tremont St., Boston.
For page see List of Advertisers.
Julius A. Zinn, 2 Beacon St., Boston.
For page see List of Advertisers.
Houghton & Clark, 396 Boylston St., Boston.
For page see List of Advertisers.
Sidney Hoffman, 59-61 Massachusetts Ave., Boston.
For page see List of Advertisers.

FLOWERS BY TELEGRAPH —

Continued

Edward MacMullin, 194 Boylston St., Boston.
For page see List of Advertisers.
J. Bretmeyer's Sons, Miami and Gratiot Aves., Detroit, Mich.
For page see List of Advertisers.
Samuel Murray, 1017 Broadway, Kansas City, Mo.
For page see List of Advertisers.
Wm. L. Rock Flower Co., 1116 Walnut St., Kansas City, Mo.
For page see List of Advertisers.
Fred C. Weber, 4326-28 Olive St., St. Louis, Mo.
For page see List of Advertisers.
H. G. Eyres, 11 N. Pearl St., Albany, N. Y.
For page see List of Advertisers.
David Clarke's Sons, 213-9-2141 Broadway, New York.
For page see List of Advertisers.
W. H. Donahoe, 17 E. 28th St., New York.
For page see List of Advertisers.
Alex. McConnell, New York.
For page see List of Advertisers.
M. A. Bowe, 1294 Broadway, New York.
For page see List of Advertisers.
Robert G. Wilson, Fulton St. & Greene Av., Brooklyn, N. Y.
For page see List of Advertisers.
Thomas Young, Jr., 500 Fifth Ave., N. Y.
For page see List of Advertisers.
Young & Nugent, 42 W. 28th St., N. Y.
For page see List of Advertisers.

FLOWER POTS

W. H. Ernest, 28th and M Sts., Washington, D. C.
For page see List of Advertisers.
A. H. Hews & Co., Cambridge, Mass.
For page see List of Advertisers.
Hillinger Bros., Ft. Edward, N. Y.
For page see List of Advertisers.

Paper pots for all early vegetables. Two inch pots \$1.00 a thousand; three inch \$1.25; four inch \$1.60. P. B. Crosby, Catsonsville, Md.

GALAX

Michigan Cut Flower Co., 38 and 40 Broadway, Detroit, Mich.
For page see List of Advertisers.
N. F. McCarthy & Co., 84 Hawley St., Boston.
Green and Bronze Galax.
For page see List of Advertisers.

GERANIUMS

R. Vincent Jr. & Sons Co., White Marsh, Md.
New and Standard Varieties.
For page see List of Advertisers.
Geraniums, surplus of Nutt, Doyle and Buchner, 2 in. pots, \$15.00 per 1000. Cash with order. Ernest Harris, Delanson, N. Y.

GLADIOLI

Arthur Cowee, Meadowvale Farm, Berlin, New York.
For page see List of Advertisers.
J. L. Moore, Northboro, Mass.
For page see List of Advertisers.
I. & J. L. Leonard, Iona, N. J.
Gladiolus Bulbs.
For page see List of Advertisers.
Gladiol. Write for leaflet. B. Hammond Tracy, Cedar Acres, Wenham, Mass.
Gladioli. Named varieties and mixtures. Send for list. E. E. Stewart, Rives Junction, Mich.

GLASS

Boston Plate & Window Glass Co., Boston.
For page see List of Advertisers.
Standard Plate Glass Co., 26-30 Sudbury St., Boston.
For page see List of Advertisers.
Metropolitan Material Co., 1398-1408 Metropolitan Ave., Brooklyn, N. Y.
For page see List of Advertisers.
S. Jacobs & Sons, 1365-79 Flushing Ave., Brooklyn, N. Y.
Foley Mfg. Co., between Western Ave. and 26th St., Chicago, Ill.
GLASS, High Grade, Double Thick Greenhouse Glass. Lord & Burnham, 1133 Broadway, N. Y.

GLAZING POINT

H. A. Dreer, Philadelphia, Pa.
For page see List of Advertisers.
GLAZING POINTS, Lord & Burnham Special Glazing Nails (Points). Lord & Burnham, 1133 Broadway, N. Y.

GREENHOUSE BUILDING MATERIAL.

Lord & Burnham Co., 1133 Broadway, New York.
For page see List of Advertisers.
Pierson U-Bar Co., 1 Madison Sq., N. Y.
For page see List of Advertisers.
A. T. Stearns Lumber Co., Neponset, Boston.
For page see List of Advertisers.
Kling Construction Co., N. Tonawanda, New York.
For page see List of Advertisers.
J. C. Moalnger Co., 117 East Blackhawk St., Chicago, Ill.
For page see List of Advertisers.
Foley Mfg. Co., between Western Ave. and 26th St., Chicago, Ill.
For page see List of Advertisers.
I. Cassidy, Summer Ave. and Erie R. R., Newark, N. J.
For page see List of Advertisers.
W. H. Lutton, Jersey City, N. J.
For page see List of Advertisers.
Geo. B. Doane, 18 Midway St., Boston.
Iron Pipe.
For page see List of Advertisers.
Metropolitan Material Co., 1398-1408 Metropolitan Ave., Brooklyn, N. Y.
For page see List of Advertisers.
S. Jacobs & Sons, 1365-79 Flushing Ave., Brooklyn, N. Y.

GREENHOUSE CONSTRUCTION

GREENHOUSE CONSTRUCTION, Semi-Iron Greenhouse, New Truss Houses and Iron Frame Houses. Lord & Burnham, 1133 Broadway, N. Y.

J. A. Payne, 260-274 Culver Ave., Jersey City, N. J.
For page see List of Advertisers.
I. Cassidy, Summer Ave. and Erie R. R., Newark, N. J.
For page see List of Advertisers.
Foley Mfg. Co., between Western Ave. and 26th St., Chicago, Ill.
W. H. Lutton, Jersey City, N. J.
For page see List of Advertisers.

GREENHOUSE HOSE

Mineralized Rubber Co., 18 Cliff St., N. Y.
For page see List of Advertisers.

GUTTERS

GUTTERS, Cast Iron Gutters, L. & B. Improved V Shaped Gutter with drip gutter attachment. Lord & Burnham, 1133 Broadway, N. Y.

HAIL INSURANCE

Florists' Hall Asso. of America.
J. G. Esler, Saddle River, N. J.
For page see List of Advertisers.

HARDY FERNS AND SUPPLIES

H. M. Robinson & Co., 15 Province St. and 9 Chapman Pl., Boston, Mass.
For page see List of Advertisers.
The Kervan Co., 113 W. 28th St., N. Y.
For page see List of Advertisers.
Michigan Cut Flower Exchange, 38 and 40 Broadway, Detroit, Mich.
Fancy Ferns.
For page see List of Advertisers.
N. F. McCarthy & Co., 84 Hawley St., Boston.
Hardy Ferns.
For page see List of Advertisers.
H. J. Smith, Hinsdale, Mass.
For page see List of Advertisers.

HEATING APPARATUS

Lord & Burnham Co., 1133 Broadway, New York.
For page see List of Advertisers.
Pierson U-Bar Co., 1 Madison Sq., N. Y.
For page see List of Advertisers.
John A. Payne, 260-274 Culver Ave., Jersey City, N. J.
For page see List of Advertisers.

In writing to Advertisers kindly mention Horticulture

HELP FURNISHED

Thos. H. Bambrick, 34 S. 7th St., Phila.
For page see List of Advertisers.

HERBACEOUS PERENNIALS

Red Oak Nurseries, Fiskeville, R. I.
For page see List of Advertisers.

HOT-BED MATS

G. H. Frost, W. Newton, Mass.
For page see List of Advertisers.

HOT-BED SASH

The A. T. Stearns Lumber Co., Neponset, Mass.

For page see List of Advertisers.

Pierson U-Bar Co., 1 Madison Sq., N. Y.
For page see List of Advertisers.

Lord & Burnham Co., 1133 Broadway, N. Y.
For page see List of Advertisers.

Foley Mfg. Co., between Western Ave. and
26th St., Chicago, Ill.

INSECTICIDES.

Nicotinide kills all greenhouse pests.
P. R. Paethorpe Co.,
Eleventh St., Owensboro, Ky.

For page see List of Advertisers.

Wm. Elliott & Sons, 201 Fulton St.,
New York.

Target Brand Insecticides.
For page see List of Advertisers.

B. G. Pratt Co., 11 Broadway, New York.

IRISES

Japanese Iris. 25 choicest varieties, large,
well rooted divisions, \$19 per 100. Yucca
filamentosa, \$15 per 100. T. H. Chivers,
Amesbury, Mass.

JAPANA CUT FLOWER HOLDER

M. V. Garusey, 130 Walola Ave.,
La Grange, Ill. Dept. M.

For page see List of Advertisers.

KENTIAS

A. Lentby & Co., Roslindale, Mass.
For page see List of Advertisers.

Godfrey Aschmann, 1012 W. Ontario St.,
Philadelphia.

For page see List of Advertisers.

LEADING RETAIL FLORISTS

Park Floral Co., Denver, Colo.
For page see List of Advertisers.

George H. Cooke, Washington, D. C.
For page see List of Advertisers.

Gude Bros. Co., 1214 F St.,
Washington, D. C.

For page see List of Advertisers.

Atlanta Floral Co., Atlanta, Ga.
For page see List of Advertisers.

M. C. & J. E. Hanswirth, 232 Michigan Ave.,
Chicago.

For page see List of Advertisers.

William J. Smyth, Michigan Ave. and 31st
St., Chicago.

For page see List of Advertisers.

Jacob Schulz, 644 4th Ave., Louisville, Ky.
For page see List of Advertisers.

Thos. F. Galvin, 134 Tremont St., Boston.
For page see List of Advertisers.

Julius A. Zion, 2 Beacon St., Boston.
For page see List of Advertisers.

Houghton & Clark, 396 Boylston St.,
Boston.

For page see List of Advertisers.

Sidney Hoffman, 59-61 Massachusetts Ave.,
Boston.

For page see List of Advertisers.

Edward MacMulkin, 194 Boylston St.,
Boston.

For page see List of Advertisers.

J. Breitmeyer's Sons, Detroit, Mich.
For page see List of Advertisers.

Samuel Murray, 1017 Broadway,
Kansas City, Mo.

For page see List of Advertisers.

Wm. L. Rock Flower Co., 1116 Walnut
St., Kansas City, Mo.

For page see List of Advertisers.

Fred C. Weber, 4326 Olive St., St. Louis,
Mo.

For page see List of Advertisers.

J. N. Champion & Co., 1026 Chapel St.,
New Haven, Conn.

For page see List of Advertisers.

H. G. Eyres, 11 N. Pearl St., Albany, N. Y.

For page see List of Advertisers.

LEADING RETAIL FLORISTS —**Continued**

David Clarke's Sons, 2139-2141 Broadway,
New York.

For page see List of Advertisers.

W. H. Donohoe, 17 E. 28th St., New York.
For page see List of Advertisers.

Alex. McConnell, New York.

For page see List of Advertisers.

M. A. Rowe, 1234 Broadway, New York.
For page see List of Advertisers.

Robert G. Wilson, Fulton St. and Greene
Ave., Brooklyn, N. Y.

For page see List of Advertisers.

Thomas Young, Jr., 500 Fifth Ave., N. Y.

For page see List of Advertisers.

Young & Nugent, 42 W. 28th St., N. Y.
For page see List of Advertisers.

NEW AND RARE PLANTS

Roae Hill Nurseries, New Rochelle, N. Y.
For page see List of Advertisers.

NICO-FUME

Kentucky Tobacco Product Co.,
Louisville, Ky.

For page see List of Advertisers.

NURSERY STOCK

John Waterer & Sons, Ltd.,
American Nursery, Bagshot, England.
For page see List of Advertisers.

New England Nurseries, Bedford, Mass.
Shrubs, Roses and Herbaceous Perennials.
Specimen Pyramidal Box.

For page see List of Advertisers.

Bay State Nurseries, N. Abington, Mass.
Herbaceous Perennials, Hardy Ornamental
Trees.

For page see List of Advertisers.

Cleary's Horticultural Co., 62 Vesey St.,
New York.

For page see List of Advertisers.

P. Ouwerkerk, 216 Jane St., Weehawken
Heights, N. J.

Holland Nursery Stock for Forcing.
For page see List of Advertisers.

American Nursery Co., 150 Broadway, New
York, N. Y.

For page see List of Advertisers.

Pierce Nurseries, Beverly Farms, Mass.
Tree Seedlings and Rooted Cuttings.
For page see List of Advertisers.

I. & J. L. Leonard, Iona, N. J.

California Privet, American Chestnuts.
For page see List of Advertisers.

D. J. Twomey, Dept. H., Geneva, N. Y.
Trees and Plants.

For page see List of Advertisers.

Carlman Ribsam, 31 Wall St.,
Trenton, N. J.

California Privet, Trees, Shrubs, Etc.
For page see List of Advertisers.

The Morris Nursery Co.,
Sales Office, 1 Madison Ave., New York.
Ornamental Trees, Evergreens, Hedge
Plants.

For page see List of Advertisers.

Eastern Nurseries (M. M. Dawson, Mgr.),
Jamaica Plain, Mass.

Hardy Trees, Shrubs, Perennials.

ORCHID PLANTS

Lager & Hurrell, Summit, N. J.
For page see List of Advertisers.

Sander, St. Albans, England.
Importers, Exporters, Growers, Hybridists
For page see List of Advertisers.

Julius Roehrs Co., Rutherford, N. J.
For page see List of Advertisers.

Carrillo & Baldwin, Secaucus, N. J.
For page see List of Advertisers.

Jos. A. Manda, 191 Valley Road, W.
Orange, N. J.

For page see List of Advertisers.

Ordonez Bros., Madison, N. J., Box 106.
For page see List of Advertisers.

PALMS

A. Leuthy & Co., Perkios St. Nurseries,
Roslindale, Mass.

For page see List of Advertisers.

Robert Craig Co., Market and 49th Sts.,
Philadelphia, Pa.

For page see List of Advertisers.

Kentia, Phoenix, etc., all sizes. Write
for new price list. Julius Roehrs Co.,
Rutherford, N. J.

PAINT AND PUTTY

PAINT AND PUTTY: Ideal Greenhouse
lead; Special Greenhouse Putty. Lord &
Burnham, 1133 Broadway, N. Y.

PANSY PLANTS.

Choice pansy plants, 50c. per 100; \$4.00
per 1000. Cash. Aug. Zirniglebel, Need-
ham, Mass.

PATENTS

Siggers & Siggers, Washington, D. C.
For page see List of Advertisers.

PEAT

Orchid peat, Rotted peat, Azalea peat,
Leaf-Mould, Live Sphagnum moss, Baled
Sphagnum moss, Green Clump moss, etc.
Jobbers' list on application. C. W. Brown-
ell & Co., Walden, N. Y.

PELARGONIUMS

R. Vincent, Jr. & Sons Co., White Marsh,
Maryland.

For page see List of Advertisers.

PEONIES

Wholesale Peony list for fall 1903 is now
ready. J. F. Rosenfield, West Point, Neb.

One of the finest collections in America.
Send 25 cts. in stamps for new edition of
Peony Manual. C. S. Harrison's Select
Nursery, York, Neb.

PHLOXES

Send 25 cts. in stamps for Phlox Manual.
Fine mixed phloxes \$1.50 per 100. C. S.
Harrison's Select Nursery, York, Neb.

PIPE AND FITTINGS

Foley Mfg. Co., between Western Ave. and
26th St., Chicago, Ill.

Eagle Metal & Supply Co., Johnson and
Union Aves., Brooklyn, N. Y.

Second-Hand Pipe and Boiler Tubes.
For page see List of Advertisers.

PIPE AND FITTINGS. Cast Iron and
Wrought Pipe, Valves, Elbows, Pipe Hooks,
Automatic Air Headers, etc. Lord &
Burnham, 1133 Broadway, N. Y.

PLANT BED CLOTH

Mineralized Rubber Co., 18 Cliff St., N. Y.
For page see List of Advertisers.

PLANT STAKES AND TRELLISES

Seele's Patent, for roses, chrysanthe-
mums, gladioli, tuberose, dahlias toma-
toes, egg plants, etc. H. D. Seele & Sons,
Manufact., Elkhart, Ind.

POT HANGERS

Pot hangers, Kramer's \$1 doz. by exp.
\$1.25 by mail. I. N. Kramer & Son, Cedar
Rapids, Ia.

PRUNING SHEARS

Rhodes Mfg. Co., Grand Rapids, Mich.
Dept. R.

RAFFIA

Raffia (colored), 20 beautiful shades.
Samples free. R. H. Conroy Co., Camden,
N. J.; 810 Washburn Ave., Chicago, Ill.

RHODODENDRONS

John Waterer & Sons, Ltd.,
American Nursery, Bagshot, England.
For page see List of Advertisers.

ROSES

Julius Roehrs Co., Rutherford, N. J.
Rambler Rose, Newport Fairy.
For page see List of Advertisers.

New England Nurseries, Inc., Bedford,
Mass.

For page see List of Advertisers.

Bay State Nurseries, N. Abington, Mass.
For page see List of Advertisers.

Ellwanger & Barry, Rochester, N. Y.
Hardy Roses.

For page see List of Advertisers.

John Cook, 318 Charles St., N. Baltimore,
Maryland.

Rose My Maryland.
For page see List of Advertisers.

Robert Craig Co., Market and 49th Sts.,
Philadelphia, Pa.

For page see List of Advertisers.

For List of Advertisers See Page 352

ROSES—Continued

Dingee-Conard Co., West Grove, Pa.
New Climbing Rose, Tausendschon.
For page see List of Advertisers.

The Morris Nursery Co.,
Sales Office, 1 Madison Ave., New York.
Ornamental Trees, Evergreens, Hedge
Plants.
For page see List of Advertisers.

400 varieties; own roots; summer grown.
Leedle Company, Springfield, Ohio.

Crimson Ramblers, 2 year, on own roots,
extra strong, at 7 cents. Gilbert Costleb,
Rochester, N. Y.

Low-huddled roses, No. 1, \$95.00; No.
1-1-2, \$65.00 1000. H. T. Jones, Elizabeth,
N. J.

SCALECIDE

B. G. Pratt Co., 11 Broadway, New York.

SEEDS

T. J. Grey Co., 32 So. Market St.,
Boston, Mass.
For page see List of Advertisers.

Joseph Breck & Sons,
51 and 52 N. Market St., Boston, Mass.
For page see List of Advertisers.

W. Atlee Burpee & Co., Philadelphia.
For page see List of Advertisers.

J. M. Thorburn & Co., 33 Barclay St., N. Y.
For page see List of Advertisers.

A. T. Boddington, 342 W. 14th St., N. Y.
For page see List of Advertisers.

H. F. Michell Co., 1017 Market St., Phila.
For page see List of Advertisers.

James Vick's Sons, Rochester, N. Y.
Vick's Superb Pansy Seed.
For page see List of Advertisers.

Ijalmar Hartmann & Co.,
12 Stormgade, Copenhagen, Denmark.
Cauliflower and Cabbage Seed.
For page see List of Advertisers.

Bickards Bros., 37 E. 19th St., New York.
For page see List of Advertisers.

R. & J. Farquhar & Co., 6-7 So. Market
St., Boston.
Giant Cyclamen Seed.
For page see List of Advertisers.

C. C. Morse & Co., 48-56 Jackson St.,
San Francisco, Cal.
For page see List of Advertisers.

H. E. Flske Seed Co., Faneuil Hall Sq.,
Boston.
For page see List of Advertisers.

Braslan Seed Growers Co., San Jose Cal.
For page see List of Advertisers.

O. V. Zangen, Hoboken, N. J.
For page see List of Advertisers.

R. Wilholt, Nakskov, Denmark.
Snowball Cauliflower Seed.
For page see List of Advertisers.

Stumpp & Walter Co., 50 Barclay St.,
New York.
For page see List of Advertisers.

Watkins & Simpson, 12 Tavistock St.,
London, Eng.
Sweet Peas.
For page see List of Advertisers.

Weeber & Don, 114 Chambers St.,
New York.
For page see List of Advertisers.

Franck Brill, Hempstead, L. I., N. Y.
Altimo Culture Co., Canfield, O.
Aster Seed.

Schlegel & Fottler Co., 26 & 28 So. Market
St., Boston.

Cyclamens, Asparagus and Summer Flower-
ing Bulbs and Roots.

Asparagus Pl. Nanns, \$2.50 per 1000.
Plant early. Asparagus Plants 14 to 18
inches high, \$6 per 100. Peter Mack, Box
172, Orlando, Fla.

500 bu. choice Canada cluster Oats
(weigh 40 lbs.); 250 bu. choice two-row Bar-
ley; field and garden seeds of all kinds.
The Bell Seed Co., Manlius, N. Y.

SHAMROCKS

John F. Rupp, Shiremanstown, Pa.
N. F. McCarthy & Co., 84 Hawley St.,
Boston.

Leonard Cousins, Jr., Concord Junction,
Mass.

SMILAX

E. A. Beaven, Evergreen, Ala.
Southern Wild Smilax; Log Mosses.
For page see List of Advertisers.

SPHAGNUM MOSS

Live Sphagnum moss, orchid peat and
orchid baskets always on hand. Lager &
Hurrell, Summit, N. I.

Fresh, clean, 5 bbl. bale, \$1.25; 2 bales,
\$2.25; 5 bales, \$5.00; 10 bales, \$9.50. Cash.
H. R. Akers, Chatsworth, N. J.

STRAWBERRY PLANTS

M. Crawford Co., Cuyahoga Falls, O.
New Strawberry, The Highland.
For page see List of Advertisers.

STEAM TRAP

E. Hippard, Youngstown, O.
For page see List of Advertisers.

VENTILATING APPARATUS

Pierson U-Bar Co., 1 Madison Sq., N. Y.
For page see List of Advertisers.

Foley Mfg. Co., between Western Ave. and
26th St., Chicago, Ill.
For page see List of Advertisers.

John A. Payne, 260-274 Culver Ave., Jersey
City, N. J.
For page see List of Advertisers.

VENTILATING MACHINERY. New
Model encased, self-oiling gear; Standard
Model Open Gear. Lord & Burnham, 1133
Broadway, N. Y.

VIOLETS

William Sim, Cliftondale, Mass.
Violet Boston.
For page see List of Advertisers.

Violet cuttings, "Marla Louisa" Rhine-
beck stock, rooted runners, May delivery
\$20.00 M. Immediate delivery, between
now and March 15th, \$10.00 M. Wm. F.
Kasting Co., 383 Ellcott St., Buffalo, N. Y.

WIREWORK

Reed & Keller, 122 W. 25th St., N. Y.
For page see List of Advertisers.

Wirework. Write for our catalogue.
Holton & Hunkel Co., Milwaukee, Wis.

William E. Heilscher's Wire Works, 38-40
Broadway, Detroit, Mich.

The "Just Right" kind. Send for price
list. Frank W. Ball, 31 East Third Street,
Clacdnati, O.

WHOLESALE FLORISTS

Boston

N. F. McCarthy & Co., 84 Hawley St.,
Boston.
For page see List of Advertisers.

H. M. Robinson & Co., 15 Province St.
and 9 Chapman Pl., Boston.
For page see List of Advertisers.

Welch Bros., 226 Devonshire St., Boston.
For page see List of Advertisers.

Buffalo

Wm. F. Kasting Co., 383-87 Ellcott St.,
Buffalo, N. Y.
For page see List of Advertisers.

Chicago

Chas. W. McKellar, 51 Wabash Ave.,
Chicago.
For page see List of Advertisers.

Peter Reinberg, 51 Wabash Ave., Chicago.
For page see List of Advertisers.

E. F. Winterson Co., 45-49 Wabash Ave.,
Chicago.
For page see List of Advertisers.

Detroit

Michigan Cut Flower Exchange, 38 and 40
Broadway, Detroit, Mich.
For page see List of Advertisers.

WHOLESALE FLORISTS—

Continued

New York

J. K. Allen, 106 W. 28th St., New York.
For page see List of Advertisers.

J. S. Fenrich, 110 W. 28th St., New York.
For page see List of Advertisers.

Ford Bros., 48 W. 28th St., New York.
For page see List of Advertisers.

H. E. Froment, 57 W. 28th St., New York.
For page see List of Advertisers.

Alex. J. Guttman, 43 W. 28th St., New
York.
For page see List of Advertisers.

E. C. Hornn, 55 W. 28th St., New York.
For page see List of Advertisers.

A. H. Langjahr, 55 W. 28th St., New York.
For page see List of Advertisers.

James McManus, 42 W. 28th St., New York.
For page see List of Advertisers.

John I. Raynor, 49 W. 28th St., New York.
For page see List of Advertisers.

W. F. Sheridan, 39 W. 28th St., New York.
For page see List of Advertisers.

Traendly & Schenck, 44 W. 28th St., New
York.
For page see List of Advertisers.

John Young, 51 W. 28th St., New York.
For page see List of Advertisers.

Moore, Hentz & Nash, 55 and 57 W. 26th
St., New York.
For page see List of Advertisers.

Frank S. Ilcks & Co., 52 W. 28th St.,
New York.
For page see List of Advertisers.

Frank Millang, 57 W. 26th St., New York.
For page see List of Advertisers.

Wm. H. Kuebler, 28 Willoughby St.,
Brooklyn, N. Y.
For page see List of Advertisers.

Philip F. Kessler, 55 and 57 W. 26th St.,
New York.
For page see List of Advertisers.

A. Moltz, 55-57 W. 26th St., New York.
For page see List of Advertisers.

B. S. Sinn, Jr., 55 W. 26th St., New York.
For page see List of Advertisers.

Millang Bros., 41 W. 28th St., New York.
For page see List of Advertisers.

Philadelphia

W. E. McKissick, 1619-1621 Ranstead St.,
Philadelphia, Pa.
For page see List of Advertisers.

Leo Nlessen Co., 1209 Arch St., Philadel-
phia, Pa.
For page see List of Advertisers.

The S. S. Pennock-Meehan Co., 1608-18
Ludlow St., Philadelphia, Pa.
For page see List of Advertisers.

Edward Reid, 1526 Ranstead St., Phila-
delphia, Pa.
For page see List of Advertisers.

Pittsburg

J. B. Murdoch & Co., 714 Penn Ave., Pitts-
burgh, Pa.
For page see List of Advertisers.

Providence, R. I.

J. Kopelman & Co., 21 Washington St.,
Providence, R. I.
For page see List of Advertisers.

San Francisco

Alex. Mann, Jr., Co., 1125 Polk St., San
Francisco, Cal.
For page see List of Advertisers.

St. Louis

H. G. Berning, 1402 Pine St., St. Louis, Mo.
For page see List of Advertisers.

Washington, D. C.

J. J. Hartt & Co., 1312 G. St. N. W.,
Washington, D. C.

WHOLESALE PLANTSMAN

Samuel A. Woodrow, 53 W. 30th St.,
New York.
For page see List of Advertisers.

In writing to Advertisers kindly mention Horticulture

List of Advertisers

	Page
Allen J. K.	33
Altimo Culture Co.	340
American Nursery	324
American Nursery Co.	324
Aschmann Godfrey	322
Atlanta Floral Co.	343
Bambrick Thos. H.	352
Barrows H. H. & Son	340
Baur Floral Co.	340
Bayersdorfer H. & Co.	344
Bay State Nurseries	324
Beaven E. A.	345
Berning H. G.	347
Boddington A. T.	339
Boston Florist Letter	343
Boston Plate and Window Glass Co.	354
Bosch, Felix	322
Bowe, M. A.	342
Braslan Seed Growers Co.	339
Breck Joseph & Sons	339
Bretmeyer's J. Sons	342
Bremond Martial	340
Bridgeman's Seed Warehouse	339
Burpee W. A. & Co.	339
Carrillo & Baldwin	341
Castle Co.	356
Cassidy I.	355
Champion J. N. & Co.	343
Chicago Carnation Co.	323
Clarke's David, Sons	342
Clery's Horticultural Co.	347
Conard & Jones Co.	322
Cook John	324
Cooke G. H.	342
Cowee A.	322
Craig, Robt. Co.	322
Crawford M. & Co.	338
Dingee & Conard Co.	324
Doane Geo. B. & Son	355
Douhoh W. H.	342
Dorner F. Sons & Co.	323
Dreer H. A.	335-354
Dysart R. J.	345
Eagle Metal & Supply Co.	354
Edgar, W. W. Co.	340
Edwards Folding Box Co.	344
Elliott Wm. & Sons	353
Ellwanger & Barry	340
Elmsford Nurseries	323
Esler J. G.	354
Ernest W. H.	354
Eyres	342
Farquhar R. & J. & Co.	339
Feurich J. S.	346
Fiske, H. E. Seed Co.	339
Foley Mfg. Co.	355
Ford Bros.	346
Froment H. E.	346
Frost G. H.	352
Fruit Auction Co.	336
Galvia Thos. F.	343
Garusey M. V.	343
Grey T. J. Co.	339
Gude Bros. Co.	342
Guttman Alex. J.	346
Haerens A.	322
Hall Assn.	354
Haines, J. E.	323
Hart, Geo. B.	343
Hartmann Hjalmar & Co.	339
Hauswirth M. C. & J. E.	342
Herbert David & Son	323
Hews A. H. & Co.	354
Hicks Frank S. & Co.	347
Hilfinger Bros.	354
Hibbard F.	355
Hoffman	343
Horan E. C.	345
Houghton & Clark	343
Jahn, H. A.	323
Kastig W. F.	347
Kentucky Tobacco Product Co.	353
Kervaa Co., The	345
Kessler, P. F.	346
King Cons. Co.	355
Kopelman J. & Co.	345
Koral Mfg. Co.	343
Kramer Bros. Fdy Co.	342
Kuebler Wm. H.	347
Lager & Hurrell	341
Langjahr, Alfred H.	346
Leouard I. & J.	322
Leuthy A. & Co.	322
Lord & Burnham Co.	355
Lutton W. H.	355
Manda Jos. A.	341
Mann, Alex. Jr. Co.	345
MacMullin E. A.	343
McCarthy N. F. & Co.	347
McConnell Alex.	342
McFarland Publicity Ser. ice, The	324
McKellar Charles W.	344
McKissick, W. E.	344
McMaous Jas.	346
Metropolitan Material Co.	355
Michell H. F. Co.	338
Michigan Cut Flower Exchange	347
Millaug Bros.	347
Millang Frank	347
Mitersahzed Rubber Co.	334
Moltz, A.	347
Montoyer J. C.	355
Moore Frank L.	354
Moore, Heutz & Nash	347
Moore, J. L.	323
Morris Nursery Co.	324
Morse C. C. & Co.	339
Murdoch J. B. & Co.	345
Murray Samuel	342
New England Nurseries	324
Niessen Leo. Co.	344
Ordonez Bros.	341
Ouwkerker P.	337
Paletthorpe P. R. Co.	353
Park Floral Co.	342
Payne John A.	354
Pennock-Meehan Co.	344
Perkins St. Nurseries	322
Peter's Nursery Co.	324
Pierce Nursery	324
Pierson, A. N.	322
Pierson F. R. Co.	323
Pierson U Bar Co.	356
Pulverized Manure Co.	353
Raynor John L.	346
Red Oak Nurseries	322
Reed & Keller	347
Reid Edw.	344
Reinberg Peter	344
Ribsam Carlman	324
Rice Bros.	344
Rickards Bros.	339
Robinson H. M. & Co.	347
Rock Wm. L. Flo. Co.	342
Roehrs Julius Co.	341
Rolker August & Sons	322-351
Rose Hill Nurseries	322
Ruscioni D.	340
Sauder & Son	341
Schulz Jacob	342
Scott Bros.	323
Scott, John	340
Sheridan W. F.	340
Siggers & Siggers	354
Sim. Wm.	323
Situations & Wants	352
Skidelsky S. S.	323
Shua B. S. Jr.	346
Smith H. J.	345
Smyth Wm. J.	342
Staudard Plate Glass Co.	355
Stearns A. T. Lumber Co.	355
Stumpp & Waller Co.	322-329
Thorburn J. M. & Co.	339
Toity Chas. H.	323
Traudly & Scheuck	346
Trowey D. J.	337
Valentine, J. A.	342
Velthuys K.	322
Vick's Jas. Sons	330
Vincent R. Jr. & Sons	322
Ward R. M. & Co.	340
Waterer John & Sons	324
Watkins & Simpson	337
Weber F. C.	342
Weeber & Don	339
Welch Bros.	344
Wiboltz, R.	339
Wilson	342
Winterson, E. F. Co.	344
Woodrow, Sam'l A.	347
Yokohama Nursery Co.	340
Young John	346
Young, Thos. Jr.	342
Young & Nugent	342
Zangen O. V.	319
Zinn, J. A.	343

New Offers in This Issue.

- ASTER SEED.**
H. E. Fiske Seed Co., 12-13 Faneuil Hall Sq., Boston.
For page see List of Advertisers.
- AUCTION SALES OF PLANTS, ETC.**
The Fruit Auction Co., 200-204 Franklin St., New York.
For page see List of Advertisers.
- CATTLEYS READY TO BLOOM: VANDA COERULEA: ORCHID BASKETS: PEAT AND SUPPLIES.**
Lager & Hurrell, Summit, N. J.
For page see List of Advertisers.
- COLD STORAGE MULTIFLORUM LILY BULBS.**
D. Ruscioni, 128 W. 6th St., Cincinnati, O.
For page see List of Advertisers.
- ENGLISH WALL FLOWERS.**
Henry A. Dreer, 714 Chestnut St., Philadelphia, Pa.
For page see List of Advertisers.
- FINE COMMERCIAL ORCHIDS DUE TO ARRIVE.**
Carrillo & Baldwin, Seacucus, N. J.
For page see List of Advertisers.
- HART'S HANDY HANDLE.**
Geo. B. Hart, 24 Stone St., Rochester, N. Y.
For page see List of Advertisers.
- HIGH CLASS PRINTED MATTER: CATALOG COVERS: POST CARDS, ETC.**
The McFarland Publicity Service, Harrisburg, Pa.
For page see List of Advertisers.
- LIVE FENCES: AMOOR AND CALIFORNIA PRIVET.**
Peter's Nursery Co., Knoxville, Tenn.
For page see List of Advertisers.
- MUSHROOM SPAWN.**
H. F. Michell Co., Philadelphia.
For page see List of Advertisers.
- RIVERTON HOSE.**
H. A. Dreer, 714 Chestnut St., Phila., Pa.
For page see List of Advertisers.
- SUNNYWOODS HOSE.**
Frank L. Moore, Clatham, N. J.
For page see List of Advertisers.
- WHOLESALE FLORISTS AND SUPPLY DEALERS.**
Rice Bros., 115 N. 6th St., Minneapolis, Minn.
For page see List of Advertisers.
- WOOD MOSS.**
D. Ruscioni, 128 W. 6th St., Cincinnati, O.
For page see List of Advertisers.
- USEFUL BOOKS.**
We can supply the following books, postpaid, at the prices listed:—
The Chrysanthemum. Herrington Price, 50 cts.
How to Make Money Growing Violets. Saltford. Price, 25 cts.
Daffodils-Narcissus and How to Grow Them. A. M. Kirby. Price, \$1.10.
Commercial Violet Culture. Dr. B. T. Galloway. Price, \$1.50.
Water Gardening. Peter Bisset Price, \$2.50.
Lawns and How to Make Them. Leonard Barron. Price, \$1.10.
Roses and How to Grow Them. By Many Experts. Price, \$1.10.
The New Cyclopedia of American Horticulture. L. H. Bailey. Four volumes; \$20.00.

WANTS, FOR SALE, ETC.
Advertisements in this column one cent a word. Initials count as words. Cash with order. All correspondence addressed "care HORTICULTURE" should be sent to 11 Hamilton Place, Boston.

HELP WANTED
WANTED—SALESMAN
To Handle Good Side Line On Commission
One who calls on Florists, Seed Houses, Nurseries, Cemetery Superintendents, Monument Dealers, etc.
The Kramer Bros. Foundry Co.
DAYTON, OHIO

HORTICULTURE needs a wide-awake representative in every town in the land. Good commission paid on advertising and subscriptions. If you are ambitious, write for terms.

SITUATIONS WANTED
GOOD MEN
When you need good men, skilled or unskilled, Write:
THOS. H. BAMBRICK
34 South 7th Street Philadelphia
Help of all kinds, including that for Florists, Nurserymen, Seedsmen and the Horticultural trade generally.

SITUATION WANTED—By all round grower. Many years experience in orchids. Private or commercial. Married. Address M., care of HORTICULTURE.
SITUATION WANTED in general greenhouse work; single, age 35, five years' experience, commercial. Address W. W., care HORTICULTURE.

FOR SALE
HOT-BED MATS
STRAW, 6x6, little used 75c to \$1.00
G. H. FROST, West Newton, Mass.
FOR SALE OR TO LET—15 acres of land, nearly all under cultivation; 20,000 sq. ft. glass, house well stocked with carnations, chrysanthemums, etc.; 8-room dwelling house, steam heated; large barn; in a city of 14,000 population, 10 miles from Boston; excellent transportation facilities. Good retail trade now established. Terms will be made satisfactory. Possession given April 1 or sooner if desired. Address A. G., care HORTICULTURE.
FOR SALE—A large consignment of 16x24 double thick American glass, A and B quality. For further information write Parshelsky Brothers, 50 Montrose Avenue, Brooklyn, N. Y.

MISCELLANEOUS WANTS
WANTED,
To buy, to lease with the right to buy, or to lease, several Greenhouses with ground where retailing and landscaping is possible.
Address L. L., care of HORTICULTURE.

Is Your Name In The Above List? If Not, Why Not?

<p>Tobacco Paper IS THE STRONGEST, BEST PACKED, EASIEST APPLIED.</p> <p>24 sheets.....\$ 0.75 144 sheets..... 3.50 288 sheets..... 6.50 1728 sheets..... 35.10</p>	<p>“NICO-FUME”</p> <p>Furnishes the Most Nicotine for the Money!</p> <p>... Manufactured by ... THE KENTUCKY TOBACCO PRODUCT CO., Louisville, Ky.</p>	<p>LIQUID OVER 40% NICOTINE</p> <p>By far the CHEAPEST.</p> <p>JUST NOTE PRICES!</p> <p>Pint.....\$ 1.50 ½ Gallon..... 5.50 Gallon..... 10.50 5 Gallons..... 47.25</p>
--	--	--

SOLUBLE FERTILIZERS.

I have read Mr. Pray's articles with a good deal of pleasure and some profit. As to the use of soluble fertilizers, the quantity to be used and the conditions under which they are used and the result to be gained is of more moment than fineness or percentage. The percentage is to be considered of first importance from a freight and cost point, but not always from that of application.

Where immediate results are required, we are glad we have our double sulphates, phosphates and nitrates. Yet how often have I wished that nitrate of soda and potash were less soluble and glad to use less soluble phosphatic and potassic fertilizers. I know scores of cases where ten times more damage has been done by injudicious applications than good obtained. Therefore when Dr. Galloway advises going slow he is giving good advice.

The quantities to be used must be left to each individual case, because the user will be in possession of facts as to origin and nature of soil, its previous and recent treatment, as well as the methods of watering and the kind of water used.

The fineness must be according to the kind of fertilizer used whether mixed or simple. Most of the mixed kinds are compounded to give the best results, or should be, for a general application in a general way. This leaves it to the grower to use simple kinds for special and immediate results. By this means he has the double advantage of prolonging the feeding of the crop or plants by mixing with his compost of soil and organic matter such complete or simple fertilizer as will give the necessary potash, phosphoric acid and nitrogen, as the crop or soil need, and further to give such future applications as will assure a continuance of perfect feeding.

Further he may get immediate results by using nitrate of soda, sulphate of ammonia, sulphate of potash and superphosphate in their proper but small proportions. Fineness does not affect any of the latter as they are chemical compounds and not mechanical mixtures and are readily dissolved and diffused throughout the soil. The best method of application is in solution and so weak that the user may almost believe that he is not giving any fertilizer to his plants at all. But if used as a surface dressing, pounding up of the nitrate of soda or running it through a corn mill will make it fine enough for that purpose.

GEO. A. BISHOP.

CATALOGUES RECEIVED.

J. F. Rosenfeld, West Point, Neb.—Wholesale Price of Peonies for Fall, 1908.

Wilfrid Wheeler, Concord, Mass.—Catalogue of Small Fruit Plants, Asparagus Roots, and other stock.

Leesley Bros., Chicago, Ill.—Wholesale Nursery Catalogue for 1908. Ornamental Trees and Shrubs in choice variety are listed.

Leedle Floral Company, Springfield, O.—Roses, "summer grown and winter rested, on own roots." Kaiserin Goldfolia is listed as a novelty.

Andorra Nurseries, Chestnut Hill, Phila., Pa.—Price List of Specimen Trees, Shrubs, Roses and Fruit, Spring, 1908. A very complete list of ornamental nursery stock.

T. C. Thurlow, Cherry Hill Nurseries, West Newbury, Mass.—Fall of 1907 and Spring of 1908 Wholesale Catalogue. Fine evergreens and ornamental trees for immediate effect.

Elm City Nursery Co., New Haven, Conn.—1908 Price List of Ornamental Trees and Shrubs, Hardy Herbaceous Plants, etc. Hydrangea arborescens grandiflora is included in the novelties offered.

Hoopes, Bro. & Thomas Company, Maple Avenue Nurseries, West Chester, Pa.—Select List of Choice Fruits and Ornamentals. Viburnum plicatum makes an effective title cover illustration, and on the back cover is shown a view of the office of the nurseries, all in Quaker gray tints. The book is the product of the J. Horace McFarland Company, who make catalogues in the same perfection that this old-established nursery firm makes the goods catalogued, so there you are.

PUBLICATIONS RECEIVED.

Part II. of the Twentieth Annual Report of the Rhode Island Agricultural Experiment Station is a volume of over 400 pages and contains much valuable information for the market gardener and small-fruit grower. There are many full page illustrations. Tests with lawn grasses and experiments with strawberry crosses are especially interesting. A good index adds to the value of the book.

Bulletin No. 32, of the Bureau of Biological Survey, U. S. Department of Agriculture, is devoted to a very thorough report of the Food Habits of the Grosbeaks, by W. L. McAtee. Three colored plates and numerous engrav-

ings illustrate the text. It is gratifying to learn that these beautifully plumaged birds consume an apparently insignificant amount of fruit and grain as compared with their services in the devouring of weed seeds and destructive insects and are proven to be of great economic value to the farmer.

Proceedings of the Congress of Horticulture, Jamestown Exposition, September 23, 1907. This volume gives a synopsis of the meetings and the papers in full which were presented at the sessions at Norfolk. The papers on horticultural conditions and progress in various sections of the country are especially worth reading. The price of the book, 108 pages, bound in cloth, is 25 cents, and copies may be had on application to H. C. Irish, Secretary, Mo. Botanical Garden, St. Louis, Mo.

SPRAY YOUR

FRUIT TREES WITH
TARGET BRAND

Guaranteed Sure Death to

SCALE

1 Gal. to 40 Cals. Water, \$1.00

W. ELLIOTT & SONS
201 Fulton St. New York

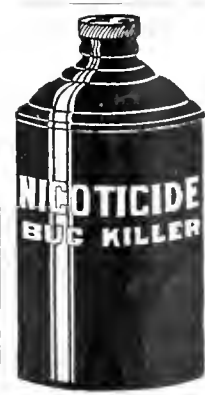

**The Best
Bug Killer and
Bloom Saver**

For **PROOF**
Write to

P. R. Paethorpe Co.
OWENSBORO, KY.



**Cattle Manure
In Bags** Shredded or
Pulverized

Best and safest manure for florists and greenhouse use, absolutely pure, no waste, no danger. Write for circulars and prices.
The Pulverized Manure Co.,
31 Union Stock Yards, Chicago

GREENHOUSES BUILDING OR CONTEMPLATED.

Lafayette, Ind.—H. Roth, rose house.
 Ross Station, Cal.—J. Nevin, rose house.
 Lynn, Mass.—Gibbs Bros., house 37x205.
 Hollywood, Cal.—A. T. Borden, range of houses.
 Milwaukee, Wis.—John Rossow, violet house.
 Oskaloosa, Ia.—Kemble Floral Co., one house.
 Philadelphia, Pa.—Gustav Saille, house 16x25.
 Danbury, Ct.—J. H. Judd, carnation house, 25x100.
 St. Charles, Ill.—Henry Swaby, house, 30x130.
 Fairbury, Ill.—Kring Bros., two carnation houses, each 30x130.
 Pittsburg, Pa.—Pittsburg Rose & Carnation Co., range of houses.

LIST OF PATENTS.

Issued February 25, 1908.

- 879,864 Guiding Device for Wheeled Agricultural Implements. George E. Gordon, Shenandoah, Iowa.
- 879,877. Fertilizer. Arthur L. Kennedy, New York, N. Y.
- 879,892. Lawn Sprinkler. Harry T. Packard, Pasadena, Cal.
- 879,959 Means for Supporting Climbing Plants. Charles Halliday, Banbridge, Ireland.
- 880,171. Garden Plow. George A. Smith and Harry E. Stein, Baxter Springs, Kans.
- 880,301. Harrow. Frank W. Harrison, Morrison, Tenn.
- 880,379. Hand Planter. Francis E. Griffith, Athens, Ga.

Issued March 3, 1908.

- 880,518. Windmill. Albert F. George, Bisbee, Ariz., assignor of one-half to John Ryan, Kansas City, Mo.
- 880,522. Watering Can. William Gray, Rochester, N. Y.
- 880,543. Wheel Fork. Alexander Kormil and Frederick Radloff, Goldendale, Wash.
- 880,549. Box for Transporting Potted Plants. Lewis P. Lord, Owatonna, Minn.
- 880,561. Fertilizer Distributer. William A. Mitchell, Fitzgerald, Ga.
- 880,628. Lawn Mower. Adelbert B. Case, Springfield, Mass.
- 880,729. Subsoil Plow. Thomas J. Green, Andalusia, Ala.

A Good Thing

between faucet and jet is



HOSE

Tested for years and adopted by the

Sunnywoods Greenhouses

(The place of origin of the rose BRIDESMAID)

MADE IN TWO BRANDS:

Sunnywoods and Sunnywoods Extra

In two sizes:—three-quarter and half-inch
 In two lengths:—50 feet and 30 feet
 (Both sizes have 3/4 inch couplings.)

PRICES.

"Sunnywoods"—3/4 inch, 16c.; 1/2 inch, 15c. per ft.
 "Sunnywoods Extra"—3/4 inch, 17c.; 1/2 inch, 16c. per ft.

The material of both brands is of the best. The "Sunnywoods Extra" is the heavier of the two brands.

For the purpose of introduction, this special offer is made:

If you send cash with your order, deduct one cent per foot from the price. And on all cash purchases of more than one hundred feet, freight will be prepaid.

FRANK L. MOORE
 CHATHAM, NEW JERSEY
 NEW YORK OFFICE, 57 West 26th Street



DREER'S
 Florist Specialties.
 New Brand—New Style.
 Hose "RIVERTON"
 Furnished in lengths up to 500 ft. without seam or joint.
 The HOSE for the FLORIST
 3/4-inch, per ft., 15 c.
 Reel of 500 ft. " 14 1/2 c.
 2 Reels, 1000 ft. " 14 c.
 1/2-inch, " 13 c.
 Reels, 500 ft. " 12 1/2 c.
 Couplings furnished.
HENRY A. DREER,
 714 Chestnut St.,
 PHILADELPHIA, PA.

ANCHOR GREENHOUSE HOSE

WEARS WELL.

PLANT BED CLOTH

Protects from Cold and Dampness.

MINERALIZED RUBBER CO.

18 Cliff Street New York

Holds Glass Firmly
 See the Point AT
PEERLESS
 FULL SIZE N° 2

Glazing Points are the best. No rights or lefts. Box of 1,000 points 75 cts. postpaid.
HENRY A. DREER,
 714 Chestnut St., Phila., Pa.

The FLORISTS' HALL ASSOCIATION OF AMERICA, insurer of 28,000,000 sq. ft. of glass. For particulars address John C. Esler, Sec'y, Saddle River, N. J.

JOHN A. PAYNE GREENHOUSE Designer & Builder

260-274 Culver Ave. JERSEY CITY, N. J.

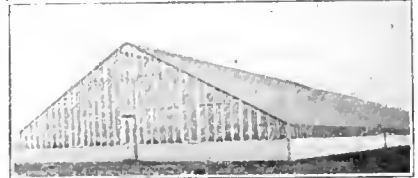

IRON FRAME SEMI-IRON FRAME TRUSS ROOF WOOD FRAME

Material Only or Erected
 Everything for the Greenhouse

SECOND HAND PIPE & BOILER TUBES

Of all sizes, in good condition, suitable for steam purpose, coupled and threaded, for sale at low rates.
 5000 feet 1 inch pipe, 3c. per ft.; 5000 feet 1 1/4 inch pipe, 4c. per ft.; 3000 feet 1 1/2 inch pipe, 5c. per ft.; 2000 feet 2 inch pipe, 6 1/2c. per ft.

EAGLE METAL & SUPPLY CO.,
 Johnson and Union Aves., BROOKLYN, N. Y.



STANDARD FLOWER POTS

Packed in small crates, easy to handle.

Price per crate		Price per crate	
1500 2 in. pots in crate	\$4.88	120 7 in. pots in crate	\$4.20
1500 2 1/4 " " " "	5.25	60 8 " " " "	3.00
1500 2 1/2 " " " "	6.00	HAND MADE	
1000 3 " " " "	5.00	48 9 in. pots in crate	\$3.60
800 3 1/2 " " " "	5.80	48 10 " " " "	4.80
500 4 " " " "	4.50	24 11 " " " "	3.60
320 5 " " " "	4.51	24 12 " " " "	4.80
144 6 " " " "	3.16	6 16 " " " "	4.80

Seed pans, same price as pots. Send for price list of Cylinders for Cut flowers, Hanging Baskets, Lawn Vases, etc. Ten percent. off for cash with order. Address Hillinger Bros., Pottery, Fort Edward, N. Y. August Rolker & Sons, Agts., 81 Barclay St., N. Y. City.

Standard Flower . . . POTS

If your greenhouses are within 500 miles of the Capitol, write us, we can save you money

W. H. ERNEST,

28th and M Street WASHINGTON D. C.

BOSTON PLATE & WINDOW GLASS CO.

GREENHOUSE GLASS

German and American

261 to 287 A St., BOSTON 20-22 Canal St.

PATENTS
 Trademarks and Copyrights

Send your business direct to Washington. Saves time and insures better service. Personal attention guaranteed. Twenty-five years' active service. SPECIALTY: "Working on the Failure of Others."

SIGGERS & SIGGERS
 PATENT LAWYERS
 Box 9, National Union Building
 Washington, D. C.

WILLIAM H. LUTTON

HORTICULTURAL ARCHITECT AND BUILDER

WEST SIDE AVENUE STATION (C. R. R. OF N. J.)
JERSEY CITY, N. J.

Have not been established 50 years, but long enough to convince the wide-awake Florist and Gardener that it is to his interest to place his work in thoroughly practical hands.

(150,000 sq. ft. glass erected in 1907 will substantiate this claim.)

And why not? My material is the best that can be secured. My iron frame construction has every modern feature that years of practical experience can embody.

AND THEN THERE IS THE COST TO BE CONSIDERED.

Why not let us take up this important question now?

GREENHOUSE GLASS

Cheaper Now Than For Years

We are taking contracts for
next Spring delivery.

WRITE FOR OUR PRICES

STANDARD PLATE GLASS COMPANY

26-30 Sudbury St. 61-63 Portland St.
BOSTON, MASS.

CYPRESS SASH BARS

82 feet or longer
HOT BED SASH
PECKY CYPRESS BENCH LUMBER

GREENHOUSES

ERECTED AND EQUIPPED COMPLETE IF DESIRED

Write for Circular "D" and Prices

The A. T. STEARNS LUMBER CO.
NEPONSET, BOSTON, MASS.

METROPOLITAN MATERIAL CO.
GREENHOUSE WRECKERS

GLASS Look at these prices New American 50 ft. to the box, 10x12 single \$1.85 per box, 10x12, 12x12 B. double \$2.20 per box, 12x14, 12x20 and 14x14, 14x20 and 16x16, 16x18 B. double \$2.40 per box, 16x20, 16x24, 12x24 B. double \$2.52 per box. In lots of 10 boxes or more. Discount on large quantities. Let us quote you on

CYPRESS MATERIAL HOTBED SASH
BOILERS PIPE FITTINGS
HOTBED FRAMES MATS

1398-1408 METROPOLITAN AV., BROOKLYN, N. Y.

THE STANDARD STEAM TRAP

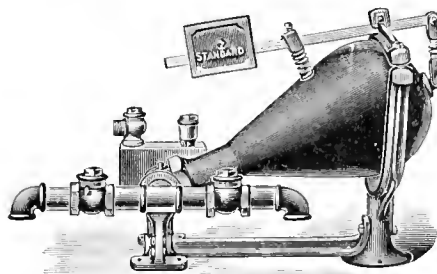

is acknowledged the best for the florist, because it is durable and does its work without trouble and annoyance, saving its cost by the economy in coal bills.

E. HIPPARD

YOUNGSTOWN, OHIO

NOW IS THE RIGHT TIME TO FIGURE **MATERIAL** AND PLAN FOR THE BUILDINGS OF THIS YEAR

FOLEY'S } QUALITY AND WORK THE BEST.
PRICES RIGHT AND LOWEST.
ESTIMATES WILL PROVE. TRY US.

Foley Ventilating Apparatus Unequaled

Will Ventilate any Size of House Easily. Send for Circular.

THE FOLEY MFG. CO. Western Ave. 25th & 26th Sts. **CHICAGO**

IRON PIPE

SECOND HAND

WROUGHT IRON PIPE, for Steam, Water, Gas or Oil, Fences or Posts. All Sizes. Price Low.

GEO. B. DOANE & SON
18 Midway Street, BOSTON
Telephone, Main 4419

R. TOMAWANDA, N. Y.

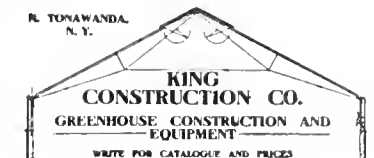

ISAAC CASSIDY

Summer Ave. & Erie R.R., Newark, N. J.

Write for Prices

GREENHOUSE MATERIAL
CONSTRUCTION FITTINGS
Bench Fittings

Material Furnished and Erected

GREENHOUSE CONSTRUCTION LUMBER

John C. Moninger Co.
117 E. Blackhawk St., CHICAGO

In ordering goods please add, "I saw it in HORTICULTURE"

New Heating Apparatus This Year?

Then don't fail to get fully informed about

THE ELECTRIC CIRCULATOR

No matter what boiler or system of heating you may prefer. Tell us the conditions and we will tell you whether the Circulator will help you and to what extent. This is the original Electric Circulator as constructed by the Holly-Castle Company and the Only One that has thus far had any practical test, but we are prepared to furnish either Double or Multiple Bladed Propellers if desired. All correspondence and enquiries cheerfully answered and advice given without charge.

CASTLE COMPANY

Heating Engineers

170 Summer Street - BOSTON, MASS.

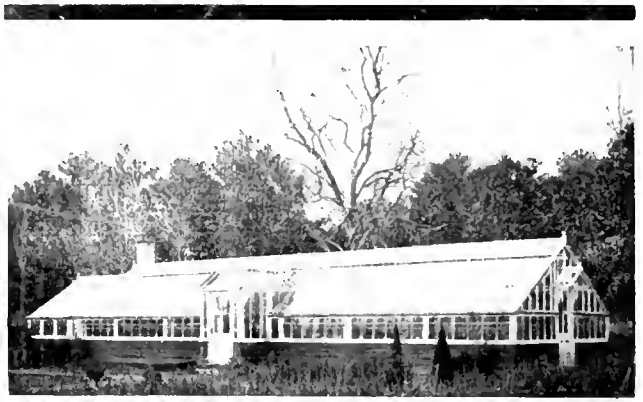

GREENHOUSE ENDURANCE

For out and out endurance — a house that will not only outlast any other, but is much the lightest — our Sectional Iron Frame Construction stands head and shoulders above others.

Gardeners and Superintendents, if you are interested in greenhouses for private places, parks, etc., send for new book — "Greenhouses as we build them."

WE MAKE EVERY PART OF A GREENHOUSE
BUT THE GLASS. WE SELL ANY PART.

LORD & BURNHAM CO.

1133 BROADWAY, . . . New York.
BOSTON Branch: 819 Tremont Building
PHILADELPHIA Branch: 1215 Filbert St.



VALUE OF THE CURVED EAVE

In the first place, every bench whether it be on the side or in the middle, receives an equal amount of light. In the short winter days, there is no band of shade cast by a gutter at the eave. There being no obstruction to the snow, the roof clears itself. Aside from these tremendous advantages, think of the increased light throughout the entire house because of the absence of heavy supporting members and the use of 24 in. wide glass. Then there is the looks. Send for the catalog

U-BAR GREENHOUSES

PIERSON

DESIGNERS AND BUILDERS



U-BAR CO.

1 MADISON AVE., NEW YORK

HORTICULTURE

Vol. VII. MARCH 21, 1908 No. 12



A MODERN ROSE HOUSE.
At Clifton, N. J.

Devoted to the
**FLORIST, PLANTSMAN,
LANDSCAPE GARDENER,**
and
Kindred Interests

Published
EVERY SATURDAY
At 11 Hamilton Place,
BOSTON, MASS.
Subscription, \$1.00

CANNA BULBS

Fine plump, Northern Grown, and in fine condition. Not to be compared with Southern grown stock, that are never thoroughly ripened and therefore are very slow to start growing.

	Doz.	100	1000		Doz.	100	1000
Allemania	\$.35	\$2.50	\$22.50	Gladiator	\$0.40	\$3.00	\$27.00
Black Prince	.40	3.00	27.00	King Edward	.50	3.50	32.00
Black Warrior	.35	2.50	22.50	Louisiana	.55	4.00	35.00
Burbank	.30	2.25	20.00	Mad. Crozy	.40	3.00	27.00
Black Musafolia	.40	3.00	27.00	Mlle. Berat	.30	2.25	20.00
Charles Henderson	.35	2.50	22.50	Musafolia	.30	2.25	20.00
Director Roetz	.35	2.50	22.50	Paul Marquant	.30	2.25	20.00
Flamingo	.30	2.25	20.00	Pres. McKinley	.35	2.50	22.50
Florence Vaughan	.35	2.50	22.50	Queen Charlotte	.35	2.50	22.50
Golden Star	.30	2.25	20.00	Robusta	.30	2.00	18.00
				Red Cross	.30	2.25	20.00

STUMPP & WALTER CO., 50 Barclay St., NEW YORK

GERANIUMS

A splendid stock of fine plants in 2 inch pots, good standard sorts and new varieties at \$2.00 per 100 and up to \$1.00 each. We will send 1000 in 20 good varieties, our selection, for \$18.50. Our special descriptive **Geranium Catalogue**, describing over 250 varieties of Geraniums and Pelargoniums mailed free to the trade.

PELARGONIUMS

In good variety, strong plants from 3 inch pots at \$1.50 per dozen, \$6.00 per 100.

HARDY CHRYSANTHEMUMS

Our collection of Hardy Chrysanthemums will compare favorably with any in the country and we have an immense stock ready for shipment. Small flowered or Button Varieties, \$2.00 per 100. Large Flowered or Aster Varieties, \$3.00 per 100. Description will be found in our Wholesale List.

DAHLIA ROOTS

We still have about 75 varieties we can offer in Cactus, Decorative, Show and Pompon true to name at \$5.00 per 100 and up for Whole Field-grown clumps. One thousand, 50 each of 20 varieties, our selection, for \$40.00, all good kinds; a splendid collection for planting or just the thing for Store Trade.

	Per 100		Per 100
Alyssum, Giant Double	\$2.00	Hardy Phlox	2.00
Ageratum, Stella Gurney	2.00	Hollyhocks, Strong 3 in. pot plants, dbl. white, pink, red and yellow	3.00
Begonia, Vernon, White and Rose	2.00	Ivy Leaved Geraniums, 6 good kinds, \$25.00 per 1000	3.00
" Gracilis, White and Rose	2.00	Lobelia, Crystal Palace Gem	2.00
Cuphaea, Cigar Plant	2.00	Lantanas, 5 varieties	2.00
Coleus, Verschaffeltii, Golden Bedder and other kinds	2.00	Lavender, 2 1/2 in. pots strong	3.00
Catadium, Esculetum, 1st size \$2.00 per 100; 2nd size	1.00	Panicum, Variegated, Handsome basket plants	2.00
Fuchsias, Black Prince and Minnesota	2.00	Swainsona, Alba	2.00
Lieutenant Muritz, White and Rose	2.50	Salvia, Bonfire and Splendens	2.00
Phenomenal	2.50	Tradescantia, Dark Variegated	2.00
Hardy English Ivy, Extra Strong, \$15.00 per 1000	2.00	Verbena, Red, White, Purple and Pink	2.00

R. VINCENT JR. & SONS COMPANY, White Marsh, Md.

YOU WANT THEM NOW

Before the cream of the varieties is all sold. The finest stock of standard

HARDY PERENNIALS

in the country. Write and we'll quote tempting prices.

Red Oak Nurseries, Fiskeville, R. I.

AZALEAS

for fall delivery, the best that are grown, also **PALMS** for spring or fall delivery, furnished by Belgium; orders booked now....

ADDRESS THE AMERICAN REPRESENTATIVES
AUGUST ROLKER & SONS, 31 Barclay Street, or P. O. Box 752, New York

Decorative Plants

Azaleas, Kentias, Rubbers, Arcas Araucarias, Pandanus, Box Trees, Euonymus, Crotons, and Eurya latifolia.

Extra good value in

EASTER PLANTS

Order Ahead.

A Leuthy & Co.

Perkins Street Nurseries, Roslindale, Mass.

Established 40 Years

Rose Hill Nurseries

New and Rare Plants

NEW ROCHELLE, N. Y.

New York Office, Siebrecht Building, 425 Fifth Avenue

GODFREY ASCHMANN

Importer and Wholesale Grower and Shipper

of Araucaria Excelsa, Compacta, Robusta and Glauca; Keotia Forsteriana and Belmoreana Azalea, Indica, etc. Cultivator of Boston, Scottii, Barrowsii, Elegantisima and Whitmanii Ferns, Ferns for dishes, Cocos, etc. Write for prices.

1012 Ontario St., Philadelphia

GLADIOLI

I can satisfactorily supply your wants for Gladioli for forcing or outdoor planting. Mixtures, color sections or named varieties of exceptional beauty.

Write for Prices

ARTHUR COWEE

Gladiolus Specialist

Meadowvale Farm, BERLIN, N. Y.

COLEUS

Verschaffeltii, Golden Queen, Fire Brand, Lord Palmerston, Queen Victoria, Beckwith's Gem. Prices of Rooted Cuttings by express, 60c. per 100; \$5 per 1000. Less than 250 of a variety will be charged at the 100 rate.

Golden Bedder, Hero, Nessey, Pearl of Orange. 75c. per 100; \$6 per 1000. Less than 250 of a variety will be charged at the 100 rate.

Fancy Varieties. A very fine assortment of twelve kinds not listed above. 75c. per 100; \$6 per 1000. 250, 10 assortment, our selection, at the 1000 rate.

MISCELLANEOUS PLANTS

AGERATUM, Stella Gurney, Princess Pauline. SALVIA Splendens, Bonfire. HELIOTROPE. Rooted cuttings, 75c. per 100; \$6 per 1000. ALTER-NANTHERA, Red and Yellow. Rooted cuttings, 50c. per 100. \$5 per 1000.

CARNATIONS

Rooted Cuttings

	100	1000
Winsor	\$6.00	\$50.00
White Perfection	2.50	20.00
Rose Pink Enchantress	3.50	30.00
Enchantress	2.50	20.00
Queen Louise	2.50	20.00

From 2 1/4 inch pots, add \$1.00 per 100.

ASPARAGUS PLUMOSUS MANUS SEEDLINGS
From flats, \$10.00 per 1000.

CHRYSANTHEMUMS

Standard varieties, ready for shipment. Rooted cuttings, \$2 per 100; \$15 per 1000. Send for list.

A. N. PIERSON, CROMWELL, CONN.

GLADIOLUS BULBS

100,000, from 1 1/4 inches up @ \$1.00 per 1000

100,000, 3/4 to 1 1/4 inches @ \$2.00 per 1000

Cash with order. Description given on request. Nice block of California Privet, \$10.00 per 1000 and up, as to quality. Write for particulars. Nice lot of American Chestnut Trees at a bargain. Thirty-five large Sugar trees, most of them sample trees.

I. & J. L. LEONARD, IONA, N. J.

HYACINTHS, TULIPS, NARCISSI

AND OTHER BULBS

ROMAN HYACINTHS and the true **PAPER WHITE GRANDIFLORA**

Ask for our Wholesale Trade List at Hillegom

K. VELTHUYS, Hillegom, Holland

Rep. by FELIX BOSCH, 260 Clarendon St., Boston.

CANNAS

Send for our List and Prices

The CONARD & JONES CO. WEST GROVE, PA.

In ordering goods please add, "I saw it in HORTICULTURE."

LIVE CANNAS

Started from Sand at \$2.00 per 100

Austria, Robusta, Pennsylvania, Chas. Henderson, Italia, Pres. Carnot, Mlle. Berat, A. Bouvier, Duke of Marlborough.

J. B. SHURTLEFF & SON, Cushman Ave., Revere, Mass.

HARDY ROSES FOR THE GARDEN

Strong Field-grown Plants

The roses here offered are extra strong two-year-old field-grown blooming plants, which if planted early, will give a large number of flowers the first year. They can be planted as early in the spring as the frost is out of the ground, and from that time until about the first week in May. We offer a grand collection of the best and choicest varieties, as follows:

HYBRID PERPETUAL OR JUNE ROSES

Frau Karl Druschki, Marchioness of Londonderry, Capt. Hayward, Mrs. R. G. Sharman-Crawford, Ulrich Brunner, Margaret Dickson, Baron de Bonstetten, Paul Neyron, Gen. Jacqueminot, Magna Charta, Mrs. John Laing, Mme. Gabrielle Luizet, Marshall P. Wilder, Gloire de Paris, Baroness de Rothschild, Prince Camille de Rohan, Fisher Holmes, Alfred Colomb, Soleil d'Or, Persian Yellow, Moss Roses, Rugosa alba and rubra, etc.

MONTHLY AND HYBRID TEA ROSES

Etoile de France, Killarney, Mme. Abel Chatenay, Countess of Gosford, Koenigen Carola, Perle von Godesberg, Gruss an Teplitz, Maman Cochet, White Maman Cochet, Belle Siebrecht, Hermosa, Mme. Caroline Testout, Souv. de Pres. Carnot, Kaiserin Augusta Victoria, American Beauty, La France, Clothilde Soupert, Prince de Bulgarie, Mme. Norbert Levavasseur (Baby Rambler), Anny Muller (Pink Baby Rambler), Catherine Ziemet (White Baby Rambler), etc.

In Climbing Roses we have a nice stock of Crimson Rambler, Lady Gay, Dorothy Perkins, Dawson, Gardenia, Tausendschon, etc.

LET US KNOW THE QUANTITY YOU WANT AND VARIETIES, AND WE WILL BE GLAD TO QUOTE LOWEST PRICES ON SAME BY RETURN MAIL.

F. R. PIERSON CO., Tarrytown-on-Hudson, New York

ROSES THAT BLOOM

from June until November

MY catalogue describes a list of the best everblooming summer garden Roses in the hardiest varieties and widest range of colors. These are the hybrid tea Roses, which are becoming more popular each year. Their everblooming qualities strongly recommend them to all who grow Roses in their gardens.

The beautiful new pink H. P., Dr. Wm. Gordon; The far-famed Queen of Spain; the new French H. T., The Lyon, an improved Soleil d'Or. The glorified Killarney, Betty, and all the leading new and old varieties; all the best varieties in Hybrid Perpetuals, Rugosas, and Penzance Sweetbriars, in strong, field-grown, dormant plants of first quality stock.

The new English Yellow Rambler, Goldfinch, the deepest colored in its class; also the American race of Ramblers, including that grand rose, Hiawatha, and its companions; Delight, Coquina and Paradise. Double Hollyhocks in sixteen assorted colors; Herbaceous Phlox and Peonies in best varieties.

My catalogue, which tells one how to grow roses, mailed on application.

M. H. WALSH, *Rose Specialist* Woods Hole, Mass.

300,000 CALIFORNIA PRIVET

	Per 1000
1-year-old, 18-24 inches, 2-4 branches.....	\$ 15.00
\$145.00 per 10,000; \$640.00 per 50,000.	
2-year-old, 2 3/4-, 5, 8 and 10 branches.....	35.00
	Per 100
6-year old, standard, 5-6-ft., heads 2-2 1/2-3 1/2-ft. diameter.....	75.00
6-year-old, standard, 4 1/2-ft., heads 2-2 1/2-ft. diam.	50.00
2-year-old, standard, 4-5-ft., heads 18-24-in diam.	40.00
6-year-old, pyramidal, well sheared, 4-5-ft. high, 3-4-ft. diameter.....	75.00
6-year-old, 3-4-ft. high, pyramidal, 2 1/2-3 ft. diam.	50.00
2-year-old, 2 1/2-3 ft. high, pyramidal, 18-24-in. diameter.....	40.00
Elms, Am., fine trees, 11-12-ft. high, 1 1/4-2-in. cal.....	40.00
Elms, Am., fine trees, 9-11-ft. high, 1 1/4-1 3/4-in. cal.....	\$250.00 per 1000
European Linden, 12-15-ft. high, 2-3-in. cal.....	60.00
Althaea, double white with maroon center, 5-6-ft. high.....	15.00
Althaea, double white with maroon center, 4-5-ft. high.....	12.00
Althaea, double white with maroon center, 3-4-ft. high.....	10.00
Spiraea Billardii, 4-ft high.....	6.00
Forsythia Viridissima, 3-4-ft. high.....	10.00
Lilac Rubra, Dr. Marley, 3-4-ft. high.....	10.00
Deutzia Crenata, 4-5-ft. high.....	11.00
Deutzia Gracilis, 4-year-old plants.....	8.00
Yucca Filamentosa, blooming plants.....	35.00

I will have a large collection of bedding plants for Spring delivery out of 25 greenhouses, such as Roses, Geraniums, Coleus, Heliotrope, Salvia Bonfire, or Scarlet Sage (which is the best bedding plant today), Lantanas, Verbenas, Begonias, Vinca Rosea, Alternantheras, red, yellow and pink; all kinds vase and hanging basket plants.

Send me your wants and I will give you price.

Garlman Ribsam

Office, 31 Wall St., TRENTON, N. J.
Greenhouses, East State St.
Nursery, Hamilton Ave.

Hardy Roses

American Grown—Superior to Imported

We have unsold at the present time the following varieties—all field grown plants, grown in our nurseries at Rochester, N. Y.:

Anne de Diesbueh	Prince Camille
Clie	Ulrich Brunner
Frau Karl Druschki	Crimson Rambler
General Jacqueminot	White Rambler
John Hopper	Yellow Rambler
Mme. G. Luizez	Phladelphus Rambler
Mrs. H. P. Wilder	Common Sweet Briar
Mrs. John Laing	Mme. G. Brunt
Paul Neyron	Wichuriana (The Type)

These plants are in our storage cellars and can be shipped at any time. Prices on request.

ELLWANGER & BARRY

Nurserymen—Horticulturists
Mount Hope Nurseries, Rochester, N. Y.

AMERICAN NURSERY CO., COMBIN-ING

FRED'K W. KELSEY, New York City
F. & F. NURSERIES, Springfield, N. J.
BLOODGOOD NURSERIES, Flushing, L.I.
N. J. & L. I. NURSERIES

We can supply you every need. Write for prices
Sales Department
150 BROADWAY, - NEW YORK

In ordering goods please add "I saw it in HORTICULTURE."

Hardy Rhododendrons Azaleas Conifers, Clematis, H. P. Roses, Shrubs and Herbaceous Plants from our
HOLLAND NURSERIES

Prices Moderate

P. OUWERKERK, 246 Jane St., Weehawken Heights
P. O. No. 1, Hoboken, N. J.

BARGAINS in TREES and PLANTS

Six for 25c., delivered free by mail
List Free, D. J. TWOMEY, Dept. H., Geneva, N. Y.

TAUSENDSCHON

or in English **Thousand Beauties**, is the sensational new Climbing Rose of the year. Every florist should have it. It is not excelled for forcing purposes and for general planting by any Climbing Rose now known, **not even bearing Crimson Rambler**. This is the coming forcing Rose. Get your stock early. Illustrated in ten colors and gold in our Catalogue for 1908, the **Leading Rose Catalogue of America**. Every Rose worth having is described in it. Copy free for the asking.

Strong plants of Tausendschon from 3-inch pots,
10 for \$1.50; \$12.00 per 100; \$100.00 per 1000.

THE DINGEE & CONARD CO., WEST GROVE, PA.

RHODODENDRONS, ANDROMEDAS, KALMIAS AND SPECIMEN EVERGREENS

JOHN WATERER & SONS, LD.

AMERICAN NURSERY

BAGSHOT, - - - ENGLAND

HARDY NORTHERN GROWN NURSERY STOCK

At Reasonable Prices

FRUIT AND ORNAMENTAL TREES, SHRUBS, VINES, ROSES AND HERBACEOUS PERENNIALS IN GREAT VARIETY

Catalogue and Price List for the asking

BAY STATE NURSERIES, NORTH ABINGTON, MASS.

NEW — NEW — RAMBLER ROSE "NEWPORT FAIRY"

To be disseminated Spring, 1908. Ask for illustrated pamphlet and prices

JULIUS ROEHRS CO., Rutherford, N. J.

SPECIMEN EVERGREENS

Box Plants, Azaleas, Rhododendrons, Roses, Herbaceous Perennials

In fact everything in hardy stock for Garden, Lawn and Landscape Planting.

General Catalogue and Trade Lists on application.

The NEW ENGLAND NURSERIES, Inc., Bedford, Mass.

LIVE FENCES

We believe we are the largest growers of Hedge plants in America—Privet our specialty—can supply any quantity both

Amoor River and California, strong plants, at \$25.00 per M. Other varieties. Prices on application.

PETER'S NURSERY COMPANY, - Knoxville, Tenn.

The MORRIS NURSERY CO.
West Chester, PA.
NURSERIES ESTABLISHED 1849

SPECIALTIES for SPRING 1908

Norway Maple, 2 1/2 in dia. and 2 1/2-3 in. dia.
Carolina Poplars, 10-12 ft., 1 1/2-2 in.
Cal. Privet Hedge Plants, 2 yrs. old 2-3 ft. and 3 and 4 yrs. old 3-4 ft. Dwarf Box, 3-6 in.
Rhododendron Hybrids, 18-24 in. and 2-3 ft. choice hardy varieties. Rhododendron Maximum, 2-8 ft., fine plants in car lots.
Kalmia Latifolia 1-4 ft., fine plants in car lots.
Blue Spruce, Koster's, 3-5 ft.
Hybrid Roses, choice varieties.

Catalogue mailed upon request. Address all communications to

Th. MORRIS NURSERY CO
Sales office, 1 MADISON AVE., NEW YORK

GRAFTED STOCK

BRIDE, BRIDESMAID and RICHMOND

Write For Prices

MONTROSE GREENHOUSES
MONTROSE, MASS.

See Our Exhibit

Horticultural Hall, Boston, or at
CHICAGO ROSE SHOW

— OF —

Newport Fairy

— AND —

you will be convinced of its good qualities. Don't fail

JULIUS ROEHRS CO.

Rutherford, N. J.

Notice to Florists

THE FRUIT AUCTION COMPANY, New York City, beginning this Spring, will inaugurate **daily auction sales at wholesale of plants, etc.**

Exceptional facilities provided in our new building, centrally located at 200, 202 and 204 Franklin Street (corner Washington Street).

Date of initial sale, **Wednesday, April 1, 1908**, at eight o'clock in the morning.

Sales daily thereafter at same hour until further notice.

For terms and all other detailed information, address:—

THE FRUIT AUCTION CO.,

P. O. Box 640 - - NEW YORK CITY

Correspondence and personal interviews cordially invited. *Payments will be made to sellers of plants the day following sale.* The movement to sell plants by auction at wholesale has the support and commendation of leading growers and importers.

The Burpee Quality in Seeds for Florists and Market Gardeners.

We have on our books the names of the leading florists and market gardeners and it is gratifying to note that our trade with these branches of the trade is constantly increasing; showing that the Burpee policy of supplying only the "Best Seeds that can be grown" is being more and more appreciated. Those who have not already received our "Blue List" of wholesale prices for market gardeners and florists should write for same at once.

Burpee's "Full Pound" Dollar Box of Sweet Peas for 1908

This New Dollar Box contains one full ounce package each of the following superb new varieties: **Queen Alexandra**, the new fadeless scarlet, **Bolton's Pink**, a superb new, rich pink, — **Agnes Eckford**, a lovely shade of soft pink, — **Horace Wright**, Eckford's new bluish maroon, and **Dobbie's Mrs. Collier**, the beautiful new primrose.

Also one full ounce package of **Prince of Wales** and each of the ten true and tried standard Sweet Peas contained in Burpee's "Bountiful" Collection advertised on page 170.

These ten are: **Burpee's Aurora**, — **Burpee's Dainty**, — **Countess Cadogan**, — **David R. Williamson**, — **Dorothy Eckford**, — **Flora Norton**, — **Ja et Scott**, — **King Edward VII** — **Othello**, and the unequalled special new **Burpee's Best Mixed** for 1908.

The pages referred to are those of **The Farm Annual for 1908**.

At regular prices "per oz." these amount to \$2.80 but all sixteen ounce packages, neatly boxed, — with "How to Grow Sweet Peas," rewritten for 1908, — will be mailed to any address in the United States upon receipt of ONE DOLLAR.

Burpee's New Pink
JANET SCOTT, —
from a photograph

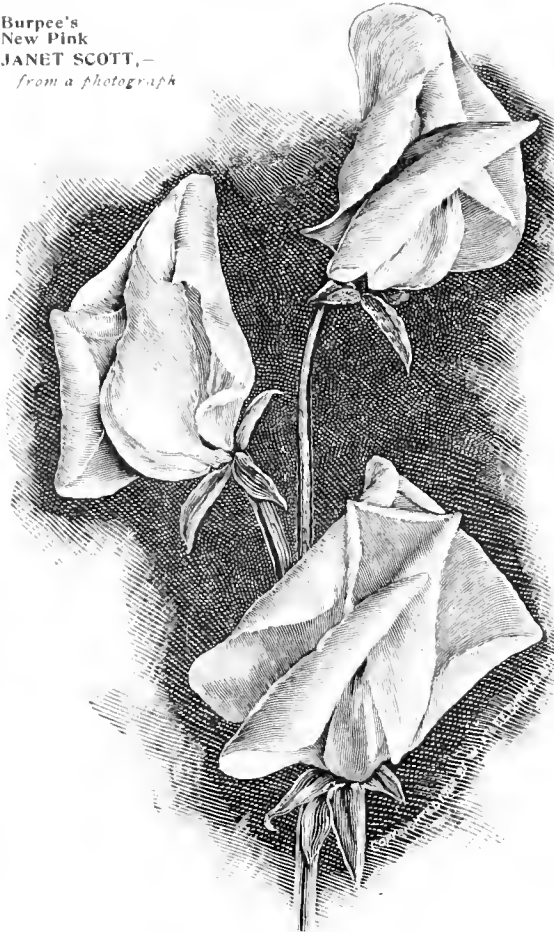

Burpee's New Collection of Nasturtiums

For 25 Cents

We will mail one full size packet each of the wonderful **New Variegated Queen**, — the first of **Burpee's New "Royal Race" of Variegated-Leaved Tall Nasturtiums**, described on page 106, — the **New Blend of Burpee's Brilliant Beauties in Tom Thumb Nasturtiums**, as described on page 115, — **Burpee's New Giant-flowered Tall Nasturtiums**, as described and illustrated on page 116, — the remarkable new complete mixture of **Burpee's Tall Ivy-Leaved**, illustrated and described on page 116 — **Dwarf Lilliput Mixed**, described on page 130, — and **Burpee's "Crazy-Quilt" Bush**, a special mixture of all dwarf varieties including the wondrously beautiful new **Bush Ivy-Leaved**.

Purchased separately these six packets would cost 55 cents.

In every instance the pages referred to are those of **THE FARM ANNUAL FOR 1908**.

See pages 96 to 99 of this catalog, where all desirable varieties of Sweet Peas are offered — the best of both old and new. We are "headquarters on Sweet Peas."

WHOLESALE

We offer any of the quick-selling, popular 25-cent collections at \$2.00 per dozen by mail, postpaid, or \$1.80 per dozen when sent by freight or express. For the "Dollar Boxes" we charge 75 cents each by freight or express, at purchaser's expense for transportation charges.

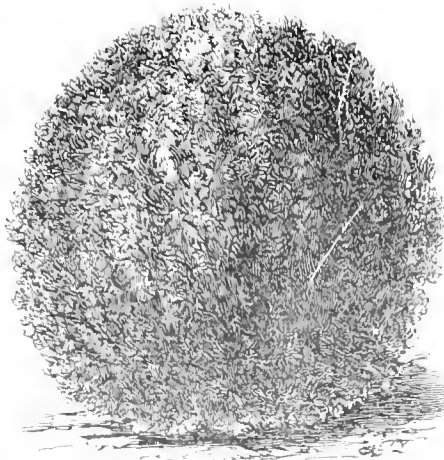

A Plant of **KOCHIA TRICOPHYLLA**.

Burpee's GEM COLLECTION of Annuals

Eight Packets Beautiful Flowers For 25 Cts.

We will mail one packet each of the following: — **Fuchsia-Floored Ipomoea**, the rapid growing and most gracefully attractive new climber — **Burpee's "Magnificent" Celosia** of remarkably brilliant color — **Dwarf French Marigold**, "Striped Perfection," lovely colors, perfectly double — **The Burpee Blend of New Giant-lowered Pansies**, — as in packet list.

The four named above are worthy a place in the garden. The collection contains also ten, one packet each: — **Little Gem Sweet Alyssum**, described on page 117 — **For hook Favorite Asters**, as described on page 117 — **Kochia Tricophylla**, described on page 117 — and **Burpee's hardworking Long-stemmed Phlox Drummondii** as described on page 140 of **The Farm Annual for 1908**.

Purchased separately these eight packets would cost 80 cts., but all are mailed for only 25 cts.: Five Collections for \$1.00.

BURPEE'S SEEDS GROW and are famous for the Uniform Excellence of their Products.



Wholesale. We offer any of the quick-selling popular 25-cent collections at \$2.00 per dozen by mail, postpaid, or \$1.80 per dozen when sent by freight or express. For "Dollar Boxes" we charge 75 cents each by freight or express, at purchaser's expense for transportation charges.

Burpee's Farm Annual for 1908.

Our complete Retail Catalog has been already mailed. If YOU have failed to receive it, kindly write at once, and a duplicate copy will be forwarded.

W. ATLEE BURPEE & CO., .. Seed.. 475 .. Philadelphia.
Growers N. 5th Street,

British Rose Culture

THE NATIONAL SOCIETY

In spite of the increased attention which is being paid in Britain to the carnation and sweet pea—fostered by their special societies—the cult of the rose has made no decline. It is only fitting that the great national emblem, and the flower which has played an important part in British history should still hold its own against all rivals. In recent years the increased observance of St. George's day by wearing a rose has given a further impetus to the demands made upon the trade growers. The work of the National Rose Society has also borne good results. By the holding of first-class shows, and disseminating practical information for the use of rosarians, a vast amount of useful work has been accomplished. The Society was founded in 1876, at a meeting of enthusiasts presided over by the late Dean Hole, whose famous book on roses is a standard work on that subject. For 28 years Dean Hole rendered sterling service as the president, and his death was an irreparable blow to the Society. The actual founder of the Society was the late Rev. H. Honeywood D'Ombraih, who from 1876 to 1902 discharged the duties of senior honorary secretary. His contributions to the horticultural press, under the title of D. Deal, were read by numerous admirers for over half a century. The memory of these noted horticultural clerics is being perpetuated by The National Rose Society. A Dean Hole medal has been established by public subscription, and a D'Ombraih cup. American readers will be interested to know that the last year those silver cups were presented by Mr. W. E. Nickerson, of Cambridge, Massachusetts, U. S. A., who has promised to give twelve more silver cups for the raisers of specially good roses for ordinary garden purposes which will be awarded by the committee during the course of the ensuing year.

A GOOD RECORD

The National Rose Society continues to increase in popular favor. During last year 597 new members have joined, this being a greater number than in any previous year. This brings up the total number of members to 2,481. In 1902 the membership totalled 890. The Society has arranged a very attractive program for this year. In July the Metropolitan exhibition will be held at the Royal Botanic Gardens, Regents Park. The provincial show will take place at Manchester on Tuesday, July 24th, in the grounds of the Royal Botanical and Horticultural Society of Manchester. Arrangements have also been made with the Royal Horticultural Society to hold an autumn show in the Society's hall in London. The Society is issuing a new work on "Enemies of the Rose," and a new edition of the "Rose Annual," which has met with so much favor amongst the members.

The other publications issued to members are a "Handbook on Pruning Roses," a new "Official Cata-

logue" of the leading varieties, a revised edition of "Hints on Planting Roses," and a "Report on the Constitution of Rose Soils." It will thus be seen that the Society is continuing the educational part which has always been a prominent feature of its work. One great factor which has distinguished the Society is the united efforts made by both the trade and amateur sections to further its interests. The leading trade growers have always been ready to contribute their finest specimens to add to the attractiveness of the shows. The prizes given for new seedlings have generally aroused a keen competition amongst the raisers, besides enabling the amateurs to see novelties which are worthy attention. Financially the Society is also sound. At the annual meeting the balance was reported to be £291. 9s. 1d. the receipts for the year having amounted to £2,244. 7s. 3d.

NEW ROSES

At the National Society's summer show a gold medal was awarded to two new roses—Queen of Spain and Lady Helen Vincent. The former is a pale flesh-colored H. T. variety, shown by Messrs. S. Bide and Sons, of Farnham, Surrey. Lady Helen Vincent is also a new H. T. of a delicate pink tint. The central petals form a pointed cone, but the outer ones droop and expand. This was raised by Messrs. Alex. Dickson & Sons, Newtownards, Ireland, who also received an award of merit from the Royal Horticultural Society. Three other new roses from this firm were also given an award of merit by the Society. These were Souvenir of Stella Gray, Mrs. Munt, and Mrs. Harold Brocklebank. The first named is a Tea variety with graceful buds of a soft yellow shade. When open the petals assume a ruddy bronze tint. Mrs. Munt is a creamy-white H. T. variety of shapely form. The petals expand fully from the centre, and their edges are rolled backwards. Mrs. Harold Brocklebank is another addition to the list of H. T.'s. It is similar in color to Mrs. Munt but different in shape. It somewhat resembles the Duchess of Portland, another of Messrs. Dickson's gold medal winners. An award of merit has also been obtained by Joseph Lowe, a H. T. variety of a rosy-pink tint, stated to be a sport from Mrs. W. J. Grant. The well formed blooms have conical centres. This was shown by Messrs. Lowe and Shawyer, of Uxbridge. Goldfinch is a new Rambler, with terminal corymbs of semi-double flowers which are of a coppery yellow shade developing to rich creamy white in the older flowers. This has emanated from Messrs. Paul & Son, Old Nurseries, Cheshunt, who also received a card of commendation from the National Rose Society.

OTHER MERITORIOUS VARIETIES

Mrs. Henry Weller (raised by Mr. H. Weller, Leatherhead, Surrey) is a decorative garden rose, resembling Killarney. The blooms are of a deep rosy carmine tint. The parentage was stated to be Mme.

Abel Chatenay and Mrs. W. J. Grant. Messrs. W. Paul & Son, of Waltham Cross, secured an award of merit for Hugo Roller. This is a new decorative H. T. The outer petals are bright deep crimson, whilst the pointed full centre is of a soft creamy yellow. Phyllis is the name of a new Baby Rambler sent out by Messrs. H. Merryweather and Sons, Ltd., of Southwell. It grows outside to a height of about two feet, in a very bushy form, with a branching habit, producing long, feathery panicles of flowers in constant succession. The color is a bright carmine-pink, shading lighter in the centre. As indicating roses in favor the following is a list of the "best 18 new roses" which a nurseryman is offering: Betty, after the style of Killarney; Charles J. Grahame, a bright scarlet crimson H. T.; Countess of Derby, a robust growing exhibition rose (H. T.); Geo. Laing Paul, a promising crimson H. T.; Hiawatha, a popular climbing Polyantha; J. B. Clark, a useful exhibition rose of a deep scarlet, shaded blackish crimson; Lady Ashton, a H. T. of vigorous growth; Madame Constant Soupert, an exhibition tea; Mons. J. Hill, a finely colored exhibition rose; Queen of Spain, described in a previous note; Richmond, a good bedding variety; Lady Rossmore, Mme. P. Rivoire, Mrs. G. W. Kershaw, Rosalind Orr, Sour. de Maria de Zayas, H. T.'s; M. H. Walsh, H. P., and Phyllis, a Polyantha.

W. J. H. Adsett,

Large Rose Houses

Though it sounds like treason to say anything against large glass houses, practical growers are not all in accord with the builders of this class of structure. A span-roofed house 50 feet wide and some hundreds of feet long must of necessity be high at the ridge, and when to this are added low, solid beds instead of the old-time benches, 3 feet or more in height, the young roses, when planted, are a long way from the glass, and do not start as freely as under the older system. Whether this late start is made up for by the use of grafted stock and ease of working wide houses remains to be seen, but more than one large grower, once partly converted to the large house theory, will, in the proposed additions this year, return to the more moderate size. Leaving the question of height, extreme length has its disadvantages independently of the difficulty of handling stock. In a rose-house known to the writer, 800 feet long, there is one part where, directly air is put on, a kind of independent circuit is set up, and it is easy to see by the behavior of the plants there that they do not relish the conditions. Green fly and mildew always attack at this point, and it is thus a kind of safety valve for the section men. In a house of moderate length these independent currents are broken up by partitions or otherwise, and, though this idea may seem far-fetched, there is more in it than at first appears.—Amer. notes in *Gardeners' Chronicle*, London.

The question of large versus small houses, as it presents itself to us, is one which will have to be settled in the dear school of experience. The subject has of course two separate phases, first, the cost of construction and maintenance of large as compared with small houses, and second, the question as to which is capable of producing the higher grade of flowers. The first, we believe, is generally conceded in favor of large houses by those

who have considered the matter at all. The second is evidently the point which is giving the critic in the above notes some cause for worryment.

His complaints resolve themselves into two divisions; dangerous draughts owing to extreme length and width, and lack of light, on account of the distance of the plants from the glass. If a house 40 feet wide and 700 feet long may be considered large, we can say, as far as our experience goes, that the fears of our critic are not well founded in either case. In this structure the temperature and ventilation, both day and night, are under more perfect control than any other house on the place, and we are firmly convinced that, in this respect at least, it is very much superior to the eight small houses which it would require to cover the same amount of ground.

The point in regard to light we think we have settled, for this house at any rate. Ordinarily the test for this would be by close observation of the plants at the varying distances from the glass. Applying this rule we must say that, so far, it would take a considerable stretch of the imagination to discover any difference in the plants, which could be attributed to lack of light caused by distance from the glass. But we have also used another method. It consists briefly in the determination of the varying intensity of light by a chemical method and we have been assured that it is extremely sensitive and absolutely accurate. Carefully applying this test we have been able to find no difference between light 5 feet from the glass and 25 feet. There may be a point at which some difference will be found, but some one will have to seek for it in a house considerably wider than 40 feet.

If the time ever comes when, in place of the whims and fancies of weak and mortal man, we have exact scientific methods for solving the complex problems of the adaptability of glass structures to plant growth, then and not until then, will the perfect greenhouse be produced.

Alex. Montgomery, Jr.

Soluble Fertilizers

The writer is pleased that Mr. Bishop has derived profit from the remarks on fertilizers, is glad to note his letter of the 14th in *HORTICULTURE* and wishes to say a word.

Mr. Bishop has wished that soluble fertilizers were less so on account of their immediate activity. Like the Jap. "We inquire to know" if he has considered whether or not less of a soluble fertilizer may not sometimes be better and easier to control than more of a less soluble one.

He speaks of damage done by "injudicious application of these quick-acting agents." It has been our fate to note the same of about every kind of plant food under the sun, but we admit at once that it is easier to over-feed with something that is one hundred times as strong as some other and, to the user, better known food. We opine, however, had the user less scorn for the chemical composition as compared to something well-known to

him the results would have been happier all around.

When one says that a quarter of a pound of nitrate of soda to the barrel of water is a real feed, no one is very much startled but when, as is often the case, it can be shown that this is much stronger than, for example, the manure water as used in that particular establishment, then the great importance of known composition can be at once appreciated.

The writer never meant to convey the impression that Dr. Galloway's advice was not good especially to those who go it blind, and he knows many do travel in this way, and as a Government official, according to President Roosevelt, he mustn't say too much!

The very fact that Dr. Galloway used soluble fertilizers probably under carefully noted tests along with ordinary compost leads one naturally to ask how much of the feed was derived from these, what strengths were used and what were the results.

The undersigned does not remember ever putting any emphasis on the fineness of soluble materials, as common experience teaches that the finer the quicker dissolved, but he did speak at some length of fine bone and rock as examples, and does maintain that their degree of fineness makes,—well, all the difference in the world.

The writer has the honor of agreeing exactly with Mr. Bishop in regard to the preparation of fertilizing solutions and in his first article on this subject spoke of the chemical value of very dilute solutions, such as Cookson's Formula, and showed at length and by comparison how weak this formula really was when used according to its originator.

We can hardly wait for Mr. Bishop to inform us if he has ever used a solution as weak as this.

Rudley M. Bray

Berberis Thunbergii

The Japanese Barberry, ubiquitous plant that it is, nearly always seems appropriate whatever the situation, the soil, or the needs. Truly it is a most versatile plant in its adaptations to particular requirements. It is not at all hard to suit in the way of soil, flourishing in every kind and even doing well where it is scant in depth, nearly as well in such a situation as does the common barberry, *Berberis vulgaris*. It is desirable for use in the general shrubbery, combining well with the other barberries, with the wild roses such as *Rosa lucida* and *Rosa blanda* and with such plants as *Rosa rugosa*, *Spiraea Thunbergii* and *Spiraea Van Houttei*. It is extremely serviceable where a low dense hedge is desirable. In fact for a hedge of such a nature it seems to be the very best plant that we have. It is particularly good for introducing into wild plantations where it is well in harmony with our own native plants such as the bayberry, the sweet fern, the wild roses and the juniper. What is more, it can successfully compete with them for its existence. Then it is an ideal game cover for it not only furnishes shelter but also food.

In habit it is symmetrical and graceful. When by itself it usually attains a height of three to four feet and a spread of four to five feet. Ultimately it may grow to a height of five feet. The branches, which are very

numerous, are stout, slightly pendulous towards the ends, and clothed with a reddish bark. The flowers are straw colored and rather interesting but not at all showy like those of the common barberry. The fruit which follows is bright red when mature and long-persistent. It is borne abundantly each year and is retained on the plant until late in the following spring. The leaves are small, agreeable in color in the summer, and in the autumn assume brilliant shades of orange and scarlet and remain until late.

So the plant is not particular as to soil or situation, serves many purposes well and is attractive at every season. In the winter there is the grace of habit, the red coloring of the twigs and the brilliant fruit. In the spring there is yet fruit and there are interesting flowers and fresh green leaves. In the summer there is a rich mass of living green. In the autumn there is the very showy fruit and the gorgeous coloring.

Berberis Thunbergii was described and illustrated in *Garden and Forest*, Vol. II, p. 52.

Daniel A. Clark.

Culture of Moschosma

Editor HORTICULTURE:

Answering your correspondent's query regarding the culture of *Moschosma* I would say that it is a very easily grown plant and so far as my experience goes is not bothered in the least by insects of any description or diseases. It does not like a very close, moist atmosphere which causes the thick leathery leaves to rot on the plant, and this is about the only trouble I have seen with it.

Cuttings may be rooted at any time from February to August. The late propagated stock flowers just as freely as the stock rooted earlier in the season, only the plants are not naturally so large. As an instance of the ease with which *Moschosma* can be grown into a large plant I would say that one expert cultivator of my acquaintance grew it six feet high and several feet through in one season from a February-rooted cutting. Place the cuttings in sand in an ordinary propagating house and they will root in some three weeks. Then pot up into a loamy compost and pot on the plants as they require it, using for later pottings about one-third of rotten manure in the soil. A temperature of 50 degrees nights seems to suit this plant better than a higher one so that we must assume that though the plant originally came from South Africa it most likely comes from a high elevation. Kept in such a temperature the *Moschosma* will be nicely in flower by the third week in December.

As a plant to grow for the wholesale plant trade it will not do, as the individual flowers drop too readily, but for private gardeners to grow for conservatory decoration few plants are finer in their season, and I have received several very complimentary letters from florists who found in it just what they needed for filling in design work rapidly and cheaply.

Charles H. Lally

HORTICULTURE

VOL. VII

MARCH 21, 1908

NO. 12

PUBLISHED WEEKLY BY

HORTICULTURE PUBLISHING CO.
11 Hamilton Place, Boston, Mass.

Telephone, Oxford 292

WM. J. STEWART, Editor and Manager

SUBSCRIPTION PRICE

One Year, in advance, \$1.00: To Foreign Countries, 2.00: To Canada, \$1.50

ADVERTISING RATES

Per Inch, 30 inches to page \$1.00.
Discounts on Contracts for consecutive insertions, as follows:
One month (4 times) 5 per cent.; three months (13 times) 10 per cent.;
six months (26 times) 20 per cent.; one year (52 times) 30 per cent.
Page and half page spaces, special rates on application.

Entered as second-class matter December 8, 1904, at the Post Office at Boston, Mass under the Act of Congress of March 3, 1879.

CONTENTS

	Page
FRONTISPIECE—A Modern Rose House.....	363
BRITISH ROSE CULTURE—W. H. Adsett.....	364
LARGE ROSE HOUSES—Alex Montgomery, Jr.....	364
SOLUBLE FERTILIZERS—Dudley M. Pray.....	364
BERBERIS THUNBERGII—D. A. Clarke.....	365
CULTURE OF MOSCHOSMA—C. H. Totty.....	365
HEARD IN THE ANTE-ROOM.....	367
A NEW BOOK ON THE ROSE.....	367
CARNATION GROWERS ORGANIZE.....	367
AMERICAN ROSE SOCIETY:	
The Art Institute—George Asmus, Portrait.....	368
Some of the Busy Men at the Meeting and Exhibi- tion, Portraits	369
The Michell Trophy—Illustrated.....	370
ROSES AT WESTERLY, R. I.....	370
ROSE APPLE BLOSSOM.....	370
NOTES ON NEWER ROSES—P. J. Lynch.....	371
ROSE GRUSS AN TEPLITZ—Illustration.....	371
A MODERN ROSE HOUSE.....	371
INDOOR COMMERCIAL ROSE CULTURE—Eber Holmes	372
OBITUARY—Willis Grant Johnson, Portrait—Julius C. Gerlach—E. Annabil—Mary Elizabeth Shaffer— Henry McGair—George Dougherty.....	373
NEWS OF THE CLUBS AND SOCIETIES:	
Gardeners' and Florists' Club of Boston—St. Louis Florist Club—Morris County Gardeners' and Florists' Society	374
Elberon Horticultural Society—The National Flower Show—Connecticut Horticultural Society..	375
Lenox Horticultural Society—St. Louis Flower Show	378
A New Society Launched.....	380
OF INTEREST TO RETAIL FLORISTS:	
New Retail Flower Stores.....	382
FLOWER MARKET REPORTS:	
Boston, Buffalo, Chicago, New York, Philadelphia, Twin Cities	382
MISCELLANEOUS:	
Personal	387
Tribune Horticulturist—C. H. P.....	387
Plant Imports	378
Incorporated	382
News Notes	382-383
Philadelphia Notes	385
Business Changes	385
Greenhouses Building or Contemplated.....	393

Once a year, it is HORTICULTURE'S cus-
tom to dedicate one issue in March to the
Rose and the American Rose Society,
giving promising new roses a conspic-
uous place in its columns and devoting liberal space to
cultural and other matters in which rose growers are
most deeply interested. The special rose issue for 1908
which we now present to our readers will, we trust, make
an impression fully as favorable as any of its predeces-
sors. It will be found to contain an unusual amount
of good, practical and eminently sensible advice on time-
ly rose-growing topics given by men, who, by assiduous
devotion and study, have attained to the position of
leaders in their specialty. While, as one of these writers
truly says, exact imitation of the methods which bring
success to one man rarely if ever wins out yet the
knowledge of another's experience and conclusions is
something that even the wisest can turn to good account.
The paper by Mr. Holmes and other articles which ap-
pear in this issue will be found of inestimable value if
carefully read and the information therein intelligently
applied. We would also bespeak for those enterprising
firms whose advertisements appear in this paper, the
kind consideration of our readers.

The meeting of New York carnation
growers mentioned in our news col-
umns has been the subject of much
comment and speculation in local
trade circles. We have no disposition to invade the pri-
vacy which it is understood the promoters of this under-
taking desire to maintain, so are not in a position to say
much concerning their grievances or their plans for
eliminating them. If the small returns from the sales of
their produce is the preponderant cause for the present
agitation it may be conceded that the season has given
good cause for disquietude. The disappointment is cer-
tainly a severe one and means many shattered hopes
for the producers, who are well entitled to our sym-
pathy and such help as it may be in our power to render.
But we can see little prospect of advancing the whole-
sale price of any flower market staples in a large city
already well supplied with wholesale dealers, by the in-
augurating of new systems of marketing. So far as the
commission dealer is concerned, he never was and never
can be an advocate of low prices and no argument is
needed to show that the causes of this year's dishearten-
ing experiences unfortunately lie far beyond the power
of either growers, commission men or trade journals to
control. We do not believe it is possible to obtain a
better price, all in all, for any staple product than an
industrious, well-trained commission dealer can com-
mand. But we are great believers in the power of or-
ganized effort, under wise direction, to accomplish much
general and individual good for those for whose inter-
ests they exist and, in a broad sense, to contribute
toward a higher standard of produce, a better market
and a consequently larger return for the producer.
Carnation growers, rose growers or any other specialists
having common grievances and common needs do well
to meet frequently and confer together, to watch ten-
dencies and developments from a broad view point, dis-
cuss ways and means of overcoming obstacles and im-
proving untoward conditions as they confront them from
time to time. To work with an intelligent, philanthropic
purpose, to disseminate light and to elevate and im-
prove by education is the proud mission of organization
in the march of progress.

HEARD IN THE ANTE-ROOM.

The Cherokee rose is called for. Why does not some enterprising grower take up this beautiful, always acceptable flower? There is "money in it."

Among the hybrid Mollis azaleas, now becoming so popular for winter forcing, as well as for garden use, Anthony Koster stand as the best yellow. The flowers are large, waxy and abundant and the color is very rich.

The seedling dahlias, Ruth Forbes and Newport, offered by Wm. F. Turner & Co., in our advertisement columns are said to be the first American seedling dahlias to receive a first class certificate of the Massachusetts Horticultural Society.

Azalea Julius Roehrs is listed to distance all other varieties in its class as an Eastern favorite as soon as it gets more plentiful. The color is a glowing cerise and such varieties as Dr. Moore and Vander Cruyssen are thrown completely in the shade when associated with this superb variety.

"What are six of the the best Flowering Geraniums? The following are recommended as being an excellent half dozen: Paul Crampel, Cannell's Crimson Bedder, Emile Zola, Duke of Bedford, Gertrude Pearson and Maxime Kovalevski." Thus saith Secretary W. N. Craig of the Gardeners' and Florists' Club of Boston.

It might be well, in consideration of the frequent mention of late of Clematis indivisa as a useful winter decorative material, to recall the fact that at the banquet given to the American Carnation Society in Boston in 1895 the mirrors in the dining hall were lavishly festooned with this lovely flowering vine, furnished by the late F. L. Harris from the H. H. Hunnewell conservatories at Wellesley.

Lily reports from various sources vary greatly. Some growers claim to have lost as high as 60 per cent. of their bulbs through disease, while others find no fault. Multiflorums, condemned right and left, are not lacking in friends—for instance, S. J. Renter of Westerly, R. I., who says his are the best in years. A very general complaint is that the bulbs are in many cases badly mixed as to height, foliage, freedom, size of flower, etc.

Wm. Sim, of Chiftondale, Mass., whose fame as a sweet pea grower has spread all over the continent, says that 48 degrees is just the right temperature for sweet peas under glass. If allowed to go down to 43 degrees they will drop their buds; at 45 the flowers will have green tips; 50 is too hot.

We have had occasion heretofore to tell about Mr. Sim's tomatoes and violets, in the culture of which he is equally expert. At the present time he keeps 25 violet pickers busy, the daily product being from fifteen to twenty thousand.

Anton Schultheis is happy in the possession of what he declares to be an ever blooming sport from Crimson Rambler rose. Well, may he revel in glee if this be so. It seems incredible but Mr. Schultheis has the young plants abundantly furnished with buds

on the growths of this season at the present time and he states that is their second blooming. The great advantage of a continuous bloomer to the rose forcers is that if a plant is not sold when first in bloom the crop of flowers may be cut and the plant set to growing again at once for another try, instead of requiring a year's rest as is the case with the old type of climbers.

A NEW BOOK ON THE ROSE.

[We can supply the following book, post paid, at the price listed.]

"Roses, Their History, Development and Cultivation;" by the Rev. Joseph H. Pemberton. The appearance of this new aspirant for public favor reminds us of the great activity of horticultural writers on a subject that is ever new. Of late years new books on rose growing have multiplied apace and the one now under notice will unquestionably occupy a prominent position among them. Sixteen years ago Senor Vergara, a Spanish rosarian, published his *Bibliografia de la Rosa* and the numerous additions both at home and abroad would seem to justify a new edition or a supplement to his work.

There is no need to remind our readers of Mr. Pemberton's competency to deal with the flower with which his name has so long been inseparably connected. His book from every point of view is worthy of the subject and the writer. In size it is a large octavo and runs into something over 300 pages. The illustrations comprise some full-paged lithographic plates of the parents of the various sections of this popular flower and others in the text explanatory of the various tools, appliances and operations connected with the culture of the rose.

Within the narrow limits at our command we cannot deal at length with the numerous contents so ably set forth by the author. We appreciate very highly the literary style of the book. It is from that point of view a marked exception to some of the modern gardening books that have come under our notice of late.

To summarize as briefly as possible, we may say that Mr. Pemberton has divided his work into two main divisions, with chapters containing numerous sub-headings. In the first part he deals with the rose, the flower of England, the botany of the rose, British wild roses, wild roses of other countries, summer flowering roses, and autumn flowering roses. Historical and literary references of course abound.

The second part is mainly cultural, and here indeed the sub-headings practically cover the whole area of rose cultivation. The appendix comprises a descriptive list of selected roses recommended for cultivation and method of pruning. There is a colored frontispiece of *Rosa canina*. Price \$2.62 net.

I take pleasure in inclosing money for renewal, especially as you give such good value for the price.

GEORGE MILNE.

Point Claire, P. Q., March 14, 1908.

PERSONAL.

Visitors in Boston: F. E. Conine, Stratford, Conn.

Harry Smith of Detroit has taken a position with the park department.

Visitors in New York: Thos. J. Grey, Boston; J. F. Bradshaw, Wallace, N. C.

A. S. Nodine has taken the management of the Lines Greenhouses, Milford, Conn.

E. E. Fletcher, a popular salesman at the Music Hall Market, Boston, and Miss Mary Twomey were married at Manchester, N. H., on March 14.

Chas. L. Seybold, superintendent of Carroll Park, is chairman of the committee in charge of the flower show to be given in connection with the exhibition of the National Sculpture Society next month in Baltimore.

R. Vincent, Jr., White Marsh, Md., with his wife, sails for Europe on April 4th on S. S. Caledonian. They will leave London on April 21 with the British Horticultural Press party for Holland and the different points of interest in Belgium. Later they will visit the principal growers of geraniums in France.

TRIBUNE HORTICOLE.

This enterprising little Belgian contemporary, founded only a year or two ago, is one of the most up-to-date gardening papers in Europe. Its editor, M. Louis Gentil was formerly at Kew and subsequently went to the Congo. After his return he was appointed curator of the Brussels Botanic Garden, a position for which his wide and exceptional experience preeminently qualified him. We notice in a recent number of the *Tribune Horticole* a capital illustration of M. Calvat's lot of new seedling chrysanthemums that were staged at the last Paris show, and also several engravings of some of his latest novelties.

C. H. P.

CARNATION GROWERS ORGANIZE.

We understand that a meeting of growers—principally carnation growers for the New York market—was held at the auction room of Wm. Elliott & Sons, last Saturday, for the purpose of discussing the business situation and adopting ways and means for improving the present market conditions and organizing for some independent plan for disposing of their product. The meeting was well attended by the Long Island growers, but the New Jersey contingent was not adequately represented, and after a lengthy discussion the meeting adjourned to meet later in New Jersey. Henry Weston of Hempstead presided.

I have been a constant reader of HORTICULTURE from the first number. It is getting better and better all the time; cannot do without it, so you will find enclosed one dollar for another year's subscription.

H. D. SEELE

Elkhart, Ind., March 19, 1908.

AMERICAN ROSE SOCIETY

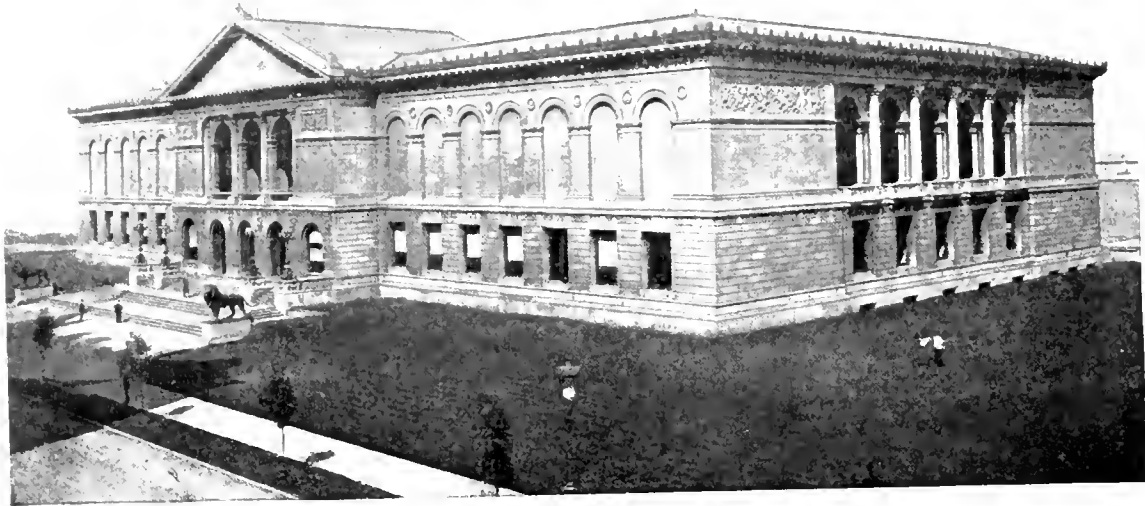

ART INSTITUTE—ROSE EXHIBITION HALL.

The Chicago men certainly have acted in the spirit which has made their city the Imperial City of the West. The beautiful Blackstone Hall in the Art Institute is to welcome the treasures of the best rose cultivators of the nation.

The exhibition will be opened on Wednesday, March 25th at 5 P. M. The first session of the annual meeting will be called at 7.30 P. M. sharp, the second session at 2.30 P. M. of the 26th, and a third meeting will follow.

The headquarters of the Society will be at the Stratford Hotel opposite the Art Institute on Jackson Boulevard.

President Simpson will open the meeting with an address. Papers or addresses will be offered by J. A. Valentine of Denver, on "Roses in Colorado;" W. A. Manda of South Orange, N. J., on "Rose Gardens;" George A. Maynadier of the Department of Agriculture, Washington, D. C., on "Soils;" Robert Craig of Philadelphia, on "Roses in Pots for Easter;" W. H. Elliott of Brighton, Mass., on "The Proper Size of Greenhouses for Commercial Purposes;" J. F. Sullivan of Detroit, "Roses for Decorative Purposes."

During the meetings the Secretary will lay before the Convention the matter of the Rose Journal as a quarterly missive; one third of the members required to start the work for a year have enrolled.

Special Prizes.

The large list of Specials betokens a most creditable interest in the coming Rose Show. August F. Poshmann, Morton Grove, Ill., is manager, George Asmus, 879 West Madison St., Chicago, Ill., is assistant manager, and will be in charge of exhibits in Art Institute,

Michigan Ave. and Adams Street, Chicago, Ill., March 25, 26, 27.

Send an application for entry to T. E. Waters, secretary of the Chicago Florists' Club, 21 E. Randolph street, or file with Benjamin Hammond, secretary of the American Rose Society. A supplementary list is ready for all interested persons. It is urgently desired that all intending exhibitors will let the committee know



GEORGE ASMUS
Exhibition Manager.

early what they will send. Last year at Washington exhibitors delayed doing this until the very last day in the afternoon, and the result was that the beautiful show which ensued, was really not known until it was on the ground, and this rush made it hard work to handle.

Division F.—Special Prizes for Cut Blooms, Etc.

F. 145. Fifty Blooms American Beauty Rose. American Rose Society's prizes, \$50, \$25.

F. 146. Display of cut Roses, all varieties. Challenge prize, valued at \$250, offered by Benjamin Dorrance; the winner to hold the prize a year and on relinquishing it to the society for another competition at the end of that period to receive a silver shield suitably engraved as a permanent record of his having held the prize. The names of the winners will be engraved consecutively on the prize.

F. 147. Outdoor Roses in bloom—in pots or tubs. \$200 cash for first prize, by Philip Breitmeyer of Detroit; \$100 cash for second prize, by Arthur T. Boddington, of New York City. Exhibits to consist of 150 plants, not more than five plants of one variety; each to be correctly labeled. All types and classes suitable for out-of-door planting may be included.

F. 148. Vase of one hundred Richmonds, \$50 in gold, offered by E. G. Hill Co., Richmond, Ind.

F. 149. Fifty Blooms of any Rose of American origin now in commerce. Silver cup, value \$25, offered by Alexander Montgomery, Natick, Mass.

F. 150. For the largest and most varied collection of Cut Roses of all classes, one or more blooms in a vase, the variety to count 65 points. Silver cup or \$25 in gold, offered by W. A. Manda, South Orange, N. J.

F. 151. Twenty-five Blooms of La Detroit. Prize of \$25 offered by John Breitmeyer's Sons, Detroit, Mich.

F. 152. The Vase of Roses showing the most artistic arrangement in the exhibition. \$25 offered by Welch Bros., Boston.

F. 153. For the most beautiful exhibit in the hall, a prize of \$20 in gold is offered by Miss M. I. Hammond, Fishkill-on-Hudson, N. Y. Each lady visiting the exhibition the first day to cast a vote on leaving the hall and the exhibit receiving the largest number of votes to receive the prize.

F. 154. One hundred Blooms of Killarney. \$50 offered by Robert Simpson, Clifton, N. J.

F. 155. Fifty Blooms of Liberty. \$25 offered by Adolph Farenwald, Hillside, Pa.

F. 156. Fifty Blooms of Killarney. \$25 offered by Dingee & Conard Co., West Grove, Pa.

F. 157. Fifty Blooms of Erldesmald.



HARRY O. MAY
Treasurer American Rose Society.



P. WELCH
Member Ex. Board, American Rose Society



BENJ. HAMMOND
Secretary American Rose Society

Some
Busy Men
at the
Meeting and
Exhibition
of the
American Rose
Society



ROBERT SIMPSON
President American Rose Society

The
Meeting and
Exhibition
will be held at the
Art Institute,
Chicago, Ill.
March 25 27, 1908.



T. E. WATERS
Rec. Secretary Chicago Florists' Club



LEONARD KULL
President Chicago Florists' Club



J. E. JENSEN
Financial Secretary Chicago Florists' Club.

\$25 offered by Traendly & Schenck, New York.

F. 158. Fifty Blooms of Bride. \$25 offered by Emil Buettnier, Park Ridge, Ill.

F. 159. Fifty Blooms of Liberty. \$25 offered by John Davis Co., Chicago.

F. 160. Fifty Blooms of Kaiserin Augusta Victoria. \$25 offered by The Glode Coal Co., Chicago.

F. 161. Fifty Blooms of Golden Gate. \$25 offered by J. A. Budlong, Chicago.

F. 162. Fifty Blooms of Ivory. \$25 offered by J. P. Wilcox, Council Bluffs, Iowa.

F. 163. The best one hundred Blooms of Pink Roses in the show. \$50 offered by Poehlmann Bros. Co., Chicago.

F. 164. Fifty Blooms of Red Roses, Richmond and American Beauties excluded. \$25 offered by Poehlmann Bros. Co., Chicago.

F. 165. One Hundred Blooms of Richmond. \$50 offered by Poehlmann Bros. Co., Chicago.

F. 166. One Hundred Blooms of Kate Moulton. First prize, \$25, offered by Wietor Bros., Chicago. Second prize, \$20, offered by Geo. Reinberg, Chicago.

F. 167. One Hundred Blooms of Uncle John. \$25 offered by Wietor Bros., Chicago.

F. 168. One Hundred Blooms of Mad. A. Chatenay. Silver Cup, value \$25, offered by Vaughan's Seed Store, Chicago.

F. 169. Fifty Blooms of American Beauty. \$50 offered by The Mogg Coal Co., Chicago.

F. 170. One Hundred Blooms of Bride. \$25 offered by The Pulverized Manure Co., Chicago.

F. 171. One Hundred Blooms of Sunrise. \$25 offered by The Florists' Review, Chicago.

F. 172. Twenty-five Blooms of Bridesmaid exhibited by growers having less than 50,000 square feet of glass. \$25 offered by Basset & Washburn, Chicago.

F. 173. Twenty-five Blooms of Bride exhibited by growers having less than 50,000 square feet of glass. \$25 offered by Basset & Washburn, Chicago.

F. 174. One Hundred Blooms of Mrs. Potter Palmer. \$50 offered by S. Freeman & Sons, Chicago.

F. 175. The best new Rose not in commerce and never exhibited before the American Rose Society, vase to contain not less than twelve and not more than twenty-five Blooms. Silver Cup, value \$25, offered by F. R. Pierson, Tarrytown, N. Y.

F. 176. Fifty Blooms of American Beauty. Cyclopedia of American Horticulture by Prof. L. H. Bailey, value \$30, offered by The American Florist Co., Chicago.

F. 177. Best Twenty-five Blooms of Pink Roses not disseminated prior to 1908. Silver Cup, value \$15, offered by J. B. Deamond Co., Chicago.

F. 178. Twenty-five Blooms of Bridesmaid. \$10 offered by W. W. Barnard Co., Chicago.

F. 179. Twenty-five Blooms of Richmond. \$10 offered by Geo. Keller & Son, Chicago.

F. 180. Twenty-five Blooms of Sunrise. \$10 offered by Leonard Kill, Chicago.

F. 181. Twenty-five Blooms of Uncle John. \$10 offered by F. R. Newbold, New York.

F. 182. Twenty-five Blooms of Killarney. \$10 offered by Kroeschell Bros. Co., Chicago.

F. 183. Twenty-five Blooms of Bride. \$10 offered by A. Dietsch Co., Chicago.

F. 184. Fifty Blooms of Mad. A. Chatenay. \$10 offered by Welland & Olinger, New Castle, Ind.

F. 185. Fifty Blooms of American Beauty. Two tons of Florist Bone offered by Darling & Co., Chicago.

F. 186. Twelve named Varieties of Hybrid Perpetuals in pots. \$10 offered by Kroeschell Bros. Co., Chicago.

F. 187. Twenty-five Blooms of Killarney. \$10 offered by Holten & Hunkel, Milwaukee, Wis.

F. 188. Exhibit of cut Roses, four varieties, Twelve Blooms of each variety, open to Private Gardeners only. \$25 offered by Harry O. May, Summit, N. J.

F. 189. Two Hundred Lily of the Valley. First prize \$10, offered by H. N. Bruns, Chicago. Second prize \$8, offered by Poehlmann Bros. Co., Chicago.

F. 190. Vase of One Hundred American Beauties. Silver Cup, valued at \$10, offered by Crane & Co., Chicago, Ill.

F. 191. Best Fifty Blooms of Tow Rose

never before exhibited for competition. Silver Loving Cup, valued at \$20, offered by Heller Bros. New Castle, Ill.

Since issuing the above list, further special prizes have been offered, as follows:

A special growers' prize for the men who actually grew the flowers, by Peter Reinberg of Chicago, a first prize of \$25, second \$15, third \$10. A sweepstake by the Horticultural Society of Chicago, of a silver medal. A. L. Randall Co. offers a prize of \$10 as a second for Ivory, and there was omitted in the printed list a prize by H. A. Michell Co., Philadelphia, for the best display of 50 Kate Moultons, a silver vase, valued at \$25.

A. L. Randall Co., 21 E. Randolph street, will receive and take care of any flowers sent for exhibition.

BENJAMIN HAMMOND,
Secretary.

Fishkill-on-Hudson, N. Y.

THE MICHELL TROPHY.



"We present a picture of the Henry F. Michell Co. trophy, for the best fifty roses, Kate Moulton, exhibited at the annual convention of the American Rose Society, Chicago, Ill., March 25 to 27.

It will be noticed that it is a practical, useful vase, having a base of six and a quarter inches and an opening at the top of six inches, so that it will take, not only considerable stems, but will hold a goodly quantity of water. The height is twelve inches.

The trophy, which was designed and made by a Philadelphia company, has a beautiful hand-chased representation of the Kate Moulton rose on the front. It is finished in French gray and is one of the most beautiful of the many beautiful prizes contributed from time to time by the H. F. Michell Co.

ROSES AT WESTERLY, R. I.

A good example of profitable rose-growing is to be seen in the houses of S. J. Reuter Co. at Westerly, R. I. Most of the standard varieties, with the exception of American Beauty, and many of the newer aspirants are grown here and all are grafted stock from one to four years old except Chatenay, which Mr. Reuter finds grows much better on its own roots. The latter is especially luxuriant and at the present time is producing blooms of phenomenal size on stems of unusual length. This rose requires a large quantity of water when in active growth.

Among the roses to be given a good trial here during the coming season are My Maryland and Cardinal. John Cook's two beautiful seedlings, also Mrs. Jardine and Mrs. Potter Palmer. The latter is expected, of course, to do as well as Chatenay has done. Miss Kate Moulton has been grown during the past season, but with indifferent success, and being so nearly like Chatenay will be discarded.

While on the subject of Mr. Reuter's establishment we might mention the superb carnations grown there—150,000 plants altogether. Young stock that has been in small pots and is now ready for a shift is being planted out in cold frames, where it will remain until moved to houses or field.

The old range of 17 houses—most of them small—covering altogether about 65,000 sq. ft., will be taken down this coming season and five large, modern houses of equal capacity in the aggregate will be erected in their place. Two additional boilers of 150 horsepower have recently been installed.

ROSE APPLE BLOSSOM.

An attempt is being made on the Continent to boom this variety, but I may say I am already acquainted with it.

Readers of the H. T. J. naturally desire to be up-to-date but at the same time have no wish to spend money on new things of no improvement on already existing varieties, and I think I should inform you that as early as last year my firm (Messrs. Hugh Low & Co.) invested somewhat heavily in "Apple Blossom." As however, this variety turned out so unsatisfactorily, my firm have not offered it to the English trade.

From my own observation I should say "Apple Blossom" was no improvement on already existing Polyanthas, and now that we have the perpetual flowering "Baby Dorothy," which has larger heads and larger individual flowers of better color, there is no room for "Apple Blossom."

Most nurserymen will agree with me it would be an advantage to reduce the number of old and inferior varieties of roses, and rose growers should take a leaf from the Carnation growers' book, for as soon as a variety becomes out of date they cease to propagate it, and so put their money on the right horse.—Lawrence J. Cook, in Hort. Trade Journal, London.

In the light of the above communication the views of an American plant grower of extensive experience—Anton Schultheis, of College Point, N. Y.—may prove interesting. Mr. Schultheis is very much impressed with the pretty little Apple Blossom rose as a subject for greenhouse forcing and especially as an Easter plant. Its continuous blooming propensities, the color and fragrance of the flowers so aptly suggested in the name Apple Blossom are, in Mr. Schultheis opinion, a sufficient assurance of the coming popularity of this novelty which will make an excellent companion for the crimson flowered "Baby Rambler."

NOTES ON NEWER ROSES.

(An interview with P. Joseph Lynch, of the Dinger & Conard Co., by G. C. Watson.)

Tausendschon, ("Thousand Beauties,") is perhaps the most important of the newer roses this year and as a seller is making a record. We consider this the most sensational climbing rose yet introduced. In addition to being a grand outdoor rose it is being taken up by the commercial florists as a good Easter plant.

J. B. Clark is not as free blooming as Liberty or Richmond, but is a much more rapid and vigorous grower and the flowers at their best will measure 7 in. across and 5 in. deep, intense scarlet shaded with dark crimson; fragrance, foliage and stem all that could be desired. Hardy as far north as Canada.

"Baby Rambler" was a great seller last year and this season we have two good companions to it—a pink in Annie Muller and a white in Catherine Zeimet.

Etoile de France might be termed a crimson-velvet Cochet, and can be used with propriety along-side of the universally popular white, pink, and yellow Cochets—using in the same connection the Baldwin ("Helen Gould") for red. The flower is almost as large as American Beauty and nearly if not quite as fragrant while the color is far superior.

The eminent horticulturist, M. de Vilmorin, stated recently that we had about reached the limit of improvement among the various classes of garden roses, and that a new species to work up from would be most likely to furnish the best results. He mentioned Rosa rugosa as the most promising subject for the purpose and the rosarians have already started on this stock. In Sir Thomas Lipton we have a valuable variety, a pure white, large and full double, fragrant and a continuous bloomer. The great objection to rugosa is its too, too, thorny stems but efforts will no doubt be made to modify this fault in future varieties.

A good word must be said in passing for Triumph de Pernet Pere. Color vivid crimson, form refined and symmetrical when open—the buds long and pointed. Jean Pernet the celebrated French rosarian thinks this is the best he has yet sent out.

We are more than ever enthusiasts on Killarney and that reminds us of a point which every grower of new roses should remember. For years we could not grow Killarney without a dose of mildew but after the stock got acclimated we began to get this variety in its true form. A grower is almost certain to be disappointed with imported stock the first year or two, and should plant wherever possible the home grown article. Where acclimated stock can be procured it is much preferable to the imported even if the first cost be greater—which it often is not.

The demand for big two and three-year pot-grown plants for May planting is increasing. While these are expensive the desire for immediate and gorgeous effect is so strong among the wealthy—an ever increasing class in our progressive country—that we are constantly improving our facilities in that direction.

If you ask us to name the best H.



CRIMSON HYBRID TEA ROSE—GRUSS AN TEPLITZ

Courtesy Ellwanger & Barry

P. red rose we would say Cheshunt Hybrid. Best grower, best color, best foliage, best every way; free flowering, magnificent as to size, perfect in form.

We like Uncle John, of course, and find the demand for it increasing yearly but we have one even better in Souvenir de Pere Notting which may be truly described as an improved Uncle John.

Among the promising roses for the future not only for the garden but for greenhouse culture we think Intensity and Olivia, both H. T.'s, stand a good show. Intensity is the deepest crimson maroon with large, full double flowers, and quite fragrant. Olivia is a deep rose, almost unique in color, of fine substance and has most beautiful buds.

A MODERN ROSE HOUSE.

We have had something to say heretofore concerning the "modern" rose house. The picture on the front page of this issue shows the interior of one. This is one of two houses built for Robert Simpson at Clifton, N. J., by Lord & Burnham Company, in 1906, of their Sectional Iron Frame Construction, having continuous ventilating

sash on the north and south side of the ridge.

There are two houses 30 feet wide by 465 feet long, built 26 feet apart, and connected with a passage 8 feet 4 inches wide. The section of these houses was designed to meet the idea of Mr. Simpson, who is one of the most successful rose growers in the country.

While the ground on which these houses are built, is level, the inside of each house is graded up 18 inches at the north side, so that the benches can be worked without any raised walks. On referring to the photograph you will notice that the ridge is carried further to the north than is usual in 3-4 span houses. This was done so that the ridge would not cast any shade on the north bench. The houses are heated by hot water, supplemented with steam. The steam pipes are also used for fumigating purposes.

The owner is justly proud of these houses, and on one interested in rose growing can visit his place without feeling that the time has been well spent and that he has added something to his previous knowledge of the business.

PRIMULAS

SOW NOW FOR
WINTER FLOWERING

CHINESE PRIMROSES

Farquhar's Giant Pinks. Pkt. \$1.00
Farquhar's Improved Giant Blue. Pkt. .75
Farquhar's Giant Red. Pkt. 1.00
Farquhar's Giant White. Pkt. 1.00
Giant Duchess. Pkt. .75
Orange King (New). Pkt. 1.00

PRIMULA STELLATA. Star Primrose

Giant White Giant Pink Giant Red
Each of the above colors. Pkt. .75

PRIMULA OBCONICA GRANDIFLORA

Giant White Giant Pink Giant Red
Each of the above colors. Pkt. .50

R. & J. Farquhar & Co. 6 & 7 So. Market St.
BOSTON, MASS.

INDOOR COMMERCIAL ROSE CULTURE.

A Paper by Eber Holmes before the Gardeners' and Florists' Club of Boston.

Let us look for a moment at the rose growing industry twenty years ago, that we may better appreciate the situation today. We had then such varieties as Gontier, Bennett, Bon Silene, Safrano, Mermet, and other good ones. It cannot be said that these have run out or have deteriorated. They have simply been superseded by better varieties. We had an illustration of this recently in the Safranoses exhibited by W. H. Elliott at the Boston show. At that time also we had the old style house, 100 ft. long and about 18 wide, with wooden walls and benches built up high to bring the plants up to the light. Now, we build glass walls and keep the plants nearer the ground. The question might naturally be asked, to what do you attribute the advance in the quality of roses produced today over those of that period? The reply is, first of all the modern house. If I had to follow the rating given to flowerers in the exhibitions taking 100 as a total, I would give the modern house 40 points. The other 60 I would divide equally between the use of grafted stock, improved methods of growing, and new and better varieties in cultivation today.

As to Size of House.

Taking these points in this order, what is the best house? and another question often asked is, what is the limit of size? We have a house 22x500 feet, even span, continuous ventilation at the top on both sides, containing five benches, which I like very much. It is a very easy house to build and maintain. The width could be increased to 34 or 36 feet at a slight additional cost, and the extra space obtained would be of great value for an extra bench or wider walks. It is an old saying that the best roses grow next to the walks, for the more air and light the plants get the better the results. We have another house 54x300 ft., which I like better, with the possible exception that it is not so easy to make repairs on a high roof as on a lower one. These large houses are easier to heat than the smaller ones. They catch every ray of sunlight in winter, fires can be banked earlier and started up later than in the smaller houses. It is no experiment now, but it is a fact that with the larger body

of air the temperature does not fluctuate as it does in a small house.

We find that our large house runs even on cold nights with less trouble than smaller ones. With ventilation at the top on both sides and front ventilators hinged at the bottom so that the air strikes upward instead of directly on the plants, the temperature can be controlled in spite of the long stretch of roof. It costs a little more proportionately to build the larger house, for it must be made stronger and braced to withstand any gale that may blow. The steeper the pitch, the greater the resistance, and the large houses are triumphs of the builder's skill. I think that 60 ft. is wide enough for any rose house. The only limits to the length are the size of the field and the purse of the builder. I believe that the largest houses produce the largest flowers, everything else being equal, and no man needs any better argument in favor of this type of house than the fact that men like Elliott and Montgomery, who are the most conservative and at the same time the most progressive rose growers we have, after years of experience with large houses, erect larger ones.

Grafting.

The next consideration is the practice of grafting so common now, in the place of using own root plants. I cannot do better than recommend Montgomery's treatise on grafting to anyone wanting this subject explained in a digestible manner. I might say, however, buy the very best stock obtainable. As soon as received, we unpack and bury in a cold cellar away from frost, first a layer of loam, then one of stock, until all are covered, taking it out as required for potting, or it can be heeled in, in a cold green-

house if there is room and no cellar or shed is available. If you have no cold house in which to start the stock, clean out a pair of benches on the north side in the coldest part of your house, and hang up burlap to keep out the sun but not so as to exclude the air. Keep well damped down and syringed, being careful not to get the roots too wet.

The grafting case, also, if it has to be built in a rose house, should be on the north side or it will be difficult to keep the heat down as the season advances. Cheese cloth makes a good shade for the grafting case, and under these same conditions a cloudy day is to be preferred to a sunny one for this operation. We prefer standing up to a table about the height of a potting bench when grafting; it is as comfortable as the position you assume when sitting down to this work, and a man can work faster when he does not have to keep changing his position. A good man will graft from 150 to 175 an hour. It is important that the grafts should not be allowed to wilt, but should be placed in the case as quickly as possible, which should be as air-tight as it can be made, and closed up at once. More plants are killed, perhaps, by improper treatment in the case than in any other way, and there is a good deal in knowing enough to let them alone for the first five days or so if the thermometer reads aright and the plants look fresh and moist. If, however, the case should be too hot, or dry, or seem too full of moisture, I would not hesitate (with the ventilators in the house closed) to open the case for a few minutes and remedy the defect. It is important to keep water out of the cut until it has healed thoroughly.

We find when buying young stock

NEW My Maryland ROSE

"My Maryland" has more good commercial points than any other Rose. Price, 2 1-2 inch pots, \$25.00 per hundred; \$200.00 per 1000; \$5.00 per dozen.

JOHN COOK, 318 N. Charles St., Baltimore, Md.

EASTER PLANTS

**Azaleas, Baby Ramblers,
Hydrangeas, Lilies,
Geraniums**

In fine condition. Write for Prices

WM. W. EDGAR CO., Waverley, Mass.

Martial Bremond

WHOLESALE GROWER OF FRENCH BULBS

— OLLIOULES, FRANCE —

A superior quality supplied at market prices. Shipments made direct. Cases marked to order.

Sole Agents

RALPH M. WARD & COMPANY
12 West Broadway - - NEW YORK

of new varieties that we often get more than we pay for in the shape of red spider, etc. In this case we always dip small lots as soon as received in tobacco water, or syringe with whale oil soap to which a little moisture has been added. In regard to the time of planting, I have seen roses successfully transplanted at any time of the year, the earlier the better for young stock. It is simply a question of money and convenience, and on large places the planting covers several months.

About "Secrets."

It is not necessary for two men to copy each other too closely to each obtain good results. In fact this may have been some man's undoing before this. Remarks written on watering are often misleading, for one soil will use up two or three times more water than another. So in other ways. Take Richmond for example; I have seen it cut down in the summer with splendid results, and thought that was the proper way to treat it after the first year. I have seen it left without pruning, standing to the top of the stakes, and also tied down, doing absolutely nothing. I have seen others tied down giving an abundance of magnificent flowers. All this goes to show that it is not so much how it is done, as who is doing it. The greatest discoveries of science and manufacturing are sometimes the result of an accident and it is no less true of some secrets in rose growing today. The observant man, in addition to experimenting, will note every detail in the working of his place, and out of some miscalculation or disaster today will possibly see the way to success later. All men make mistakes; the ones who make the least are the most successful.

There are laws governing plant life and growth which must be obeyed, but the man growing roses for profit who can distinguish between the superficial and the fundamental, and produce good stock with economy, which is the key note of commercial success, is well on his way to the top of the ladder.

(To be Continued)

The American Association of Landscape Architects held its monthly meeting in Boston at Hotel Brunswick on March 10, with an attendance of 16. F. M. Clark of Boston was a guest and spoke on dock, harbor and water-front improvements. A. A. Shurtleff spoke on "Municipal Improvements." Frederic L. Olmsted, Jr., presided.

OBITUARY.

Willis Grant Johnson.

Prof. Willis G. Johnson, Associate Editor of the American Agriculturist, died at his home in New York City on March 11. Prof. Johnson was well-informed on agricultural topics and fruits and especially on fruit tree pests, having formerly served as state entomologist of Maryland. He



WILLIS GRANT JOHNSON

had a very wide acquaintance and the news of his death in the midst of his usefulness will be a severe shock to a large circle of friends. Prof. Johnson was an earnest, self-reliant, always busy man, courteous and companionable in manner and a ready talker on every phase of farm and garden work. He leaves a wife and two children.

E. Annabil.

E. Annabil of McPherson, Kan., died suddenly on March 6, in his sixty-ninth year. Until his retirement from business two years ago Mr. Annabil was at the head of the Annabil & Co. Seed House. A widow and five children survive him.

Julius C. Gerlach.

Julius C. Gerlach, who died at St. Augustine, Fla., on March 9, located

in Newark, N. J., about forty-three years ago, and has continued in the florist business in that city until within five years, as the junior partner in the firm of Begerow & Gerlach. Mr. Gerlach was much interested in public affairs and did a great deal of charitable work. He was unmarried.

Mrs. Mary Elizabeth Shaffer.

We are sorry to report the death of Mrs. Mary Elizabeth Shaffer, mother of Geo. C. Shaffer, a well known retailer of Washington, D. C. Mrs. Shaffer died on the morning of March 16th, after a short illness.

Henry McGair.

Henry McGair, who until within a few years carried on a florist business in Olneyville, R. I., died on March 5 at his home.

George E. Dougherty.

George E. Dougherty, florist in Jay St., Brooklyn, N. Y., died on March 5. A father, brother and sister survive him.

American Hardy RHODODENDRONS

The Right Way to Grow Them

JUST PUBLISHED. FREE.

HARLAN P. KELSEY, Owner, SALEM, MASS.
Highlands Nursery 1800 ft. elevation in the Carolina Mountains, and Salem Branch Nursery.

DAHLIAS

Novelties and Standard Varieties

Our Leaders—RUTH FORBES and NEWPORT

Send for free catalogue

WILLIAM F. TURNER & COMPANY
New Bedford - - - Mass.

DAHLIAS. Now is the time to place your order for bulbs which will insure you getting named varieties in any quantity; prompt delivery.

DAVID HERBERT & SON,
Successors to L. K. Peacock, Inc.
ATCO, N.J.

100,000 DAHLIAS

Premium Stock, guaranteed true to name.
500,000 large Flowering Gladioli, hundreds of colors and variations mixed. Wholesale prices on application. Order now for spring delivery. Catalogue free.
J. L. MOORE, Northboro, Mass.

THE BOSTON VIOLET

The people today are looking for New Violets just as much as they are for new roses or carnations.

THE BOSTON VIOLET

For the past two years has been placed before the most sceptical buyers in America and they prefer it to any other.

THERE'S A REASON

The Boston Violet is the largest, the most fragrant, it has a very pleasing color, and it is a great keeper.

THE BOSTON VIOLET

Is a variety that is early grown, it is the strongest grower and is in crop from September to May.

THE BOSTON VIOLET

Was awarded a First Class Certificate of Merit by the Massachusetts Horticultural Society and a Report of Superior Merit by the Gardeners' and Florists' Club of Boston.

Distribution will Commence in April. Order Now.

PRICES—\$2 per 12; \$12 per 100; \$100 per 1000.

WILLIAM SIM, : : CLIFTONDALE, MASS.

NEWS OF THE CLUBS AND SOCIETIES.

GARDENERS' AND FLORISTS' CLUB OF BOSTON.

The announcement that Eber Holmes, of the Montrose Greenhouses, one of our most successful rose growers, would read a paper on Indoor Commercial Rose Culture was sufficient to bring out a large and deeply interested crowd at the March meeting of this club. The paper proved to be as expected a very valuable and eminently practical addition to the literature of the rose growing fraternity and at its close its author was accorded a most enthusiastic vote of thanks. W. H. Elliott, being called upon, talked interestingly on the topics, Why do we succeed? Why do we fail? He said that failure is more often due to lack of attention than to lack of knowledge. Tricks and secrets are of no avail without the partnership of man and eternal vigilance. There are a thousand little things that make for success. The greatest mistake a grower can make is in pinning his faith to one idea; too much attention to soils and too little to air and water; fertilizers are a great stumbling block and are the cause of more failures than anything else. High attainments are made possible with best equipment; modern outfits bring greater opportunities but they also bring greater burdens and close application to every detail is the main factor in success. Mr. Elliott's remarks were received with full appreciation. It was announced that William Sim

would give a talk on Sweet Peas at the April meeting.

On the exhibition table were exhibits as follows: From W. H. Elliott, Eber Holmes and R. T. McGorum fine roses, including Richmond, Killarney, Bride, Bridesmaid and Mrs. Morgan; Jos. Fuller, double blue lobelia; Wm. Sim, Boston, violets and sweet peas; H. F. Calder, violets; H. F. Wood, seedling violet No. 7; W. W. Rawson & Co., Anchusa Italica, Dropmore var. Honorable mention was given to the two last named exhibits.

ST. LOUIS FLORIST CLUB.

This club held their monthly meeting on March 12, only twenty members being present. Vice-President G. H. Augermuller was in the chair. The trustees reported that a hall had been secured at 11th and Locust streets in the Bowman building, and by vote it was decided to hold future meetings there. Fred Ammann reported for the potting committee that little progress is being made; subscriptions for stock will be received until May 14, and blanks can be found at any of the wholesale florists. There were but two exhibits of roses, both from Illinois, by J. F. Ammann and E. W. Guy. The judges pronounced them highly commendable. An interesting discussion followed. Ed. Easterday of Nokomis, Ill., was a visitor. Flower shows, and how to make them attractive to the trade, will be discussed at the April 9th meeting.

MORRIS COUNTY GARDENERS' AND FLORISTS' SOCIETY.

"Carnation Night" on March 11 was a great success. The exhibition tables were filled, the quality of the flowers was fully up to the standard of last year and some considered better. The attendance was larger than we ever had. New York, Orange, Newark, Tewksbury, Mass., Morristown, Madison, Dover and Montclair, all had their delegates and we had all we wanted to do to seat them comfortably. A. R. Kennedy read an able paper on the cultivation of the carnation. He is an advocate of the indoor method of planting direct from pots into the bench, and the flowers he has exhibited at the various meetings show that it is with him entirely successful.

A. Roper came in person and brought Bay State, a grand variegated variety. It scored 90 points and was awarded a certificate of merit. Seedling No. 21 from same grower scored 76 points and got honorable mention; his carnation No. 1000 received a vote of thanks. John E. Haines, through O. A. Miller, sent Imperial, Pink Imperial and John E. Haines, which had previously received certificates of merit. Harvard from J. D. Cockeroff scored 85 points; certificate of merit. John Green had red seedling No. 1 and white seedling No. 2. Judges were favorably impressed and would like to see them in larger quantity. Carnation No. 20, from W. A. Manda, scored 80 points; honorable mention. May

SEE THIS CRATE

It shows how we pack lilies and why our plant shipments always arrive in good condition. Order now for Easter and we'll take care of you.

Crimson Rambler
Lady Gay
Dorothy Perkins
 and other Rambler
 Roses in bloom.

Genistas
Azaleas
Rhododendrons
Hydrangeas
 and other Flowering
 Plants.



Roses
Carnations
Violets

Quotations on thousand lots. No finer goods have ever been offered.

WELCH BROTHERS, 226 Devonshire St., Boston, Mass.

from Baur & Smith, honorable mention. Cultural certificates were awarded A. R. Kennedy, gardener to Dr. L. D. Ward, for White Lawson and Victory; John R. Mitchell, Rose Pink Enchantress and Winsor; A. Herrington, carnations Beacon, Robt. Craig, White Perfection and Enchantress, and stock Queen Alexandra and Cattleya Trianae, John Dervan, gardener to A. C. Van Gassbeck, mixed roses; Herbert Entwistle, gardener to Julius Cattin, Primula obconica; H. B. Vyse, gardener to A. R. Whitney, Cineraria hybrida. Votes of thanks to Daille-douze Bros., on Afterglow, which had previously been certificated; R. M. Schultz for Enchantress; John Downing, gardener to Dr. D. H. McAlpin, Winsor and vase mixed carnations; Florham Farms for Anemone St. Bridgld, and display of indoor cauliflower.

The meeting on April 8 will be "Rose Night." John R. Mitchell, who has shown his ability as a grower, has promised an essay. We hope to get most of the new things and our own members promise to make up on standard varieties, so a good show is in sight. E. REGAN.

ELBERON HORTICULTURAL SOCIETY.

The regular meeting was held on March 9, President W. Wood in the chair, with a large attendance. Mr. Collins, florist, of So. Elberon, read a very interesting paper on landscape gardening and a lively discussion followed. A hearty vote of thanks was accorded Mr. Collins. Mr. McFarlane White Plains, N. Y., scored the highest number of points for 1908. A.

Bauer staged a vase of Stock Queen Alexandra, and scored 95 points; J. Kennedy, vase of hyacinths, 85 points. An exceedingly well-grown specimen of a large single-flowering pelargonium, Kingswood, novelty 1907, grown by A. Bauer, received certificate of merit. G. Masson tendered his resignation as secretary, as he is to take another position, and the society thanked him for his good services. A. Bauer succeeds him for the remainder of the year. After adjournment the ladies of the members were invited in and Mr. Logan entertained all with his phonograph. At the next meeting, March 23, W. Robertson will read a paper on "How to make a vegetable garden." A. BAUER, Sec'y.

CONNECTICUT HORTICULTURAL SOCIETY.

The regular meeting of this society was held in Bardeck Hall, New Britain, Conn., March 13. The society usually conducts its meetings in County Building, Hartford, but on this occasion the entire body were the guests of the New Britain members.

President Huss read an exhaustive paper on the rose, tracing its history from the remote ages to the present day, and included valuable cultural remarks. J. Gerard gave an interesting address on the duties and privileges of the amateur, and emphasized the value of membership in a live horticultural society. Mr. Lorenzen gave an interesting account of his recent Central American trip. Alexander Cumming, City Forester, Hartford, read a paper on the arrangement and care of shrubs and pointed out how

largely a tastefully arranged shrubbery added to the value of property.

Mr. Shultz read an amusing paper, prepared by a New Britain school girl, on "The trials of the amateur gardener". One of the points made by the youthful authoress was, that when the average New Britain hubby postponed his home-coming until the "wee sma' hours", his ready excuse was that he had been up to Hartford, attending a meeting of C. H. Society. Mr. Shultz also acted as chairman and his tact and ready wit added much to the enjoyment and success of the meeting. There was a large number of members present and altogether this meeting will be remembered as one of the most successful held under the auspices of the society.

A. C., JR., Sec'y.

THE NATIONAL FLOWER SHOW.

The preliminary premium list for the great National Flower Show to be held in Chicago, November 6-15, 1908, has been issued. There are 350 classes, regular and special, each carrying from one to four premiums. It is a remarkable list and is liberal enough to bring out a big response in exhibits. We shall have occasion to refer to it at greater length in the near future. We hope every interested reader will send to Secretary Rudd for a copy. It is well worth perusal, and gives some little idea of the magnitude of the long-talked-of-event.

The next meeting of the New York Florists' Club will be held in the old meeting room, Grand Opera House Building, Monday, April 13.

SOME NEW ROSES



MISS BEATRICE.

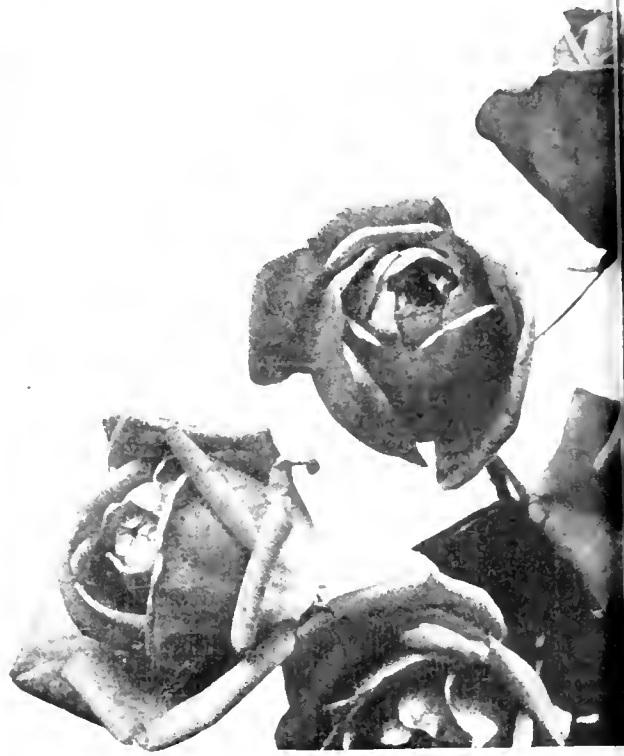

MY M

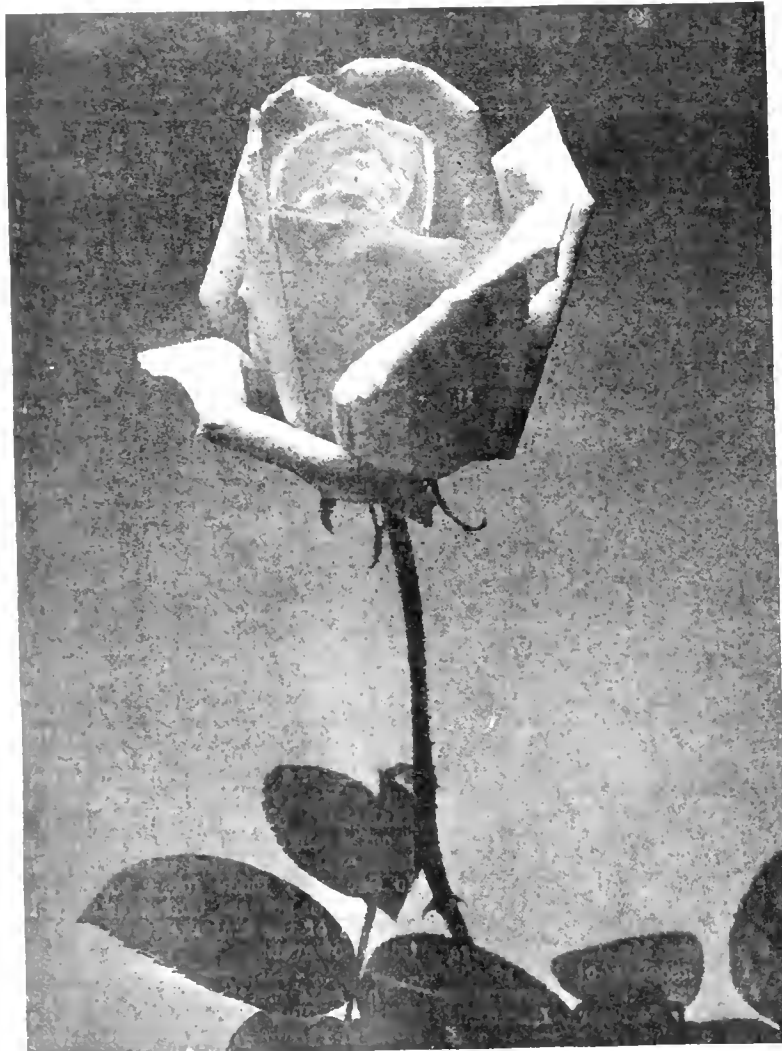

WHITE KILLARNEY.



RHEA REID.

WORTH HAVING



'LAND.



MRS. POTTER PALMER.



MADONNA.

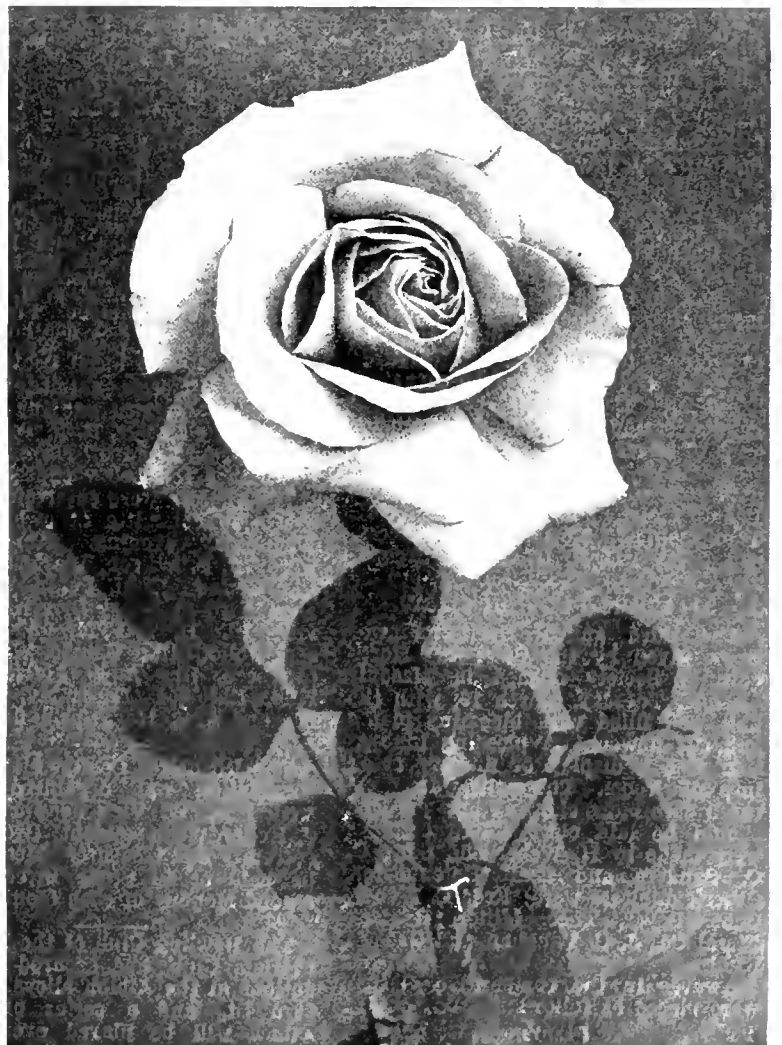

MRS. JARDINE.

LENOX HORTICULTURAL SOCIETY.

The annual Rose and Carnation night was held March 7th in the society's rooms, and was the most successful ever held. Some sixty vases were shown of the leading varieties and the quality was very high. In the various carnation colors Beacon seemed to be the most popular scarlet, Winsor in pink, White Perfection and White Enchantress in white, Pink Imperial in dark pink and Enchantress in light pink; Mrs. Patten as a variegated out-classed Variegated Lawson and Harlowarden as a crimson showed strongest among the older varieties. The new crimson, Harvard, shown by J. D. Cockerott, as well as Wanoka, exhibited by Wanoka Greenhouses, were much admired and were given highest award.

A splendid vase of gardenias was shown by F. Heeremans, whose success with them has been far above the average. Stocks cut from four-inch pots running from 2 1-2 feet to 3 1-2 in length were shown by A. H. Wingett, the varieties being Queen Alexandra, Beauty of Nice and Princess Alice. A bunch of 300 Princess of Wales violets of unsurpassed quality was shown by F. Heeremans. Boston violet sent by Wm. Sim unfortunately arrived in very poor condition. Roses were exhibited by A. H. Wingett and F. Heeremans. Also a salmon-pink sport of Beacon carnation by the former.

The following is the list of prize winners. First prizes in carnation classes to F. Heeremans for Winsor, Enchantress, Robert Craig and Helen Gould; A. H. Wingett for White Perfection, Pink Imperial, and Mrs. M. A. Patten; A. J. Loveless for Beacon and White Enchantress; D. Dunn for Winsor and Red Lawson; G. Breed for Harlowarden and Deheim; S. Carlquist for Enchantress. First prizes in rose classes to A. H. Wingett for Bride, Bridesmaid and Richmond; F. Heeremans for Liberty and American Beauty. Certificates of merit to J. D. Cockerott for carnation Harvard; Wanoka Greenhouses for carnation Wanoka. Certificates of cultural commendation to A. H. Wingett for vase of mixed stocks. Diplomas to F. Heeremans for carnation Enchantress, gardenias and violets; Wm. Sim for Boston violet. The judges were G. H. Thompson, E. J. Norman and R. Spiers. G. H. INSTONE, Sec'y.

ST. LOUIS FLOWER SHOW.

The third annual Spring Flower Show given by the St. Louis Horticultural Society opened in Masonic Temple, Tuesday, March 10, with the hall well filled with blooming plants and cut flowers. A pleasing innovation was a display of nursery stock in a side room. The walls were decorated with maps showing how gardens should be laid out. These displays were made by H. Weber and Sons, C. C. Sanders and Emil Rotenhofer. Other exhibitors were: Fred C. Weber, Chas. Beyer, Theo. Miller, Benzela Floral Co., J. C. Vaughan and Geo. A. Kuhl.

Awards in the competitive classes were placed as follows:

Plants.

Collection of bulbous plants in bloom,

COLD STORAGE LILY OF VALLEY

Florists

It will pay you to force some cold storage for Easter. Now is the time to order Extra Selected Pips, \$14.00 per 1000. Full case of 2000 Pips, \$27.00.

Headquarters for LIL. FOKMOSUM. Stock limited. Order quick.

Write for our Wholesale Catalogue.

HENRY F. MICHELL COMPANY

1016 Market Street, Philadelphia, Pa.

Wm. Schray & Sons; 2nd, Koenig Floral Co.; 3rd, Geo. B. Windler. Fifty foliage and blooming plants, Wm. Schray & Sons; 2nd, C. Young & Sons Co.; 3rd, Koenig Floral Co. Ten geraniums in bloom, Koenig Floral Co. Twelve mignonette, John Held; Twelve cyclamens, John Held. Specimen plant in bloom, Wm. Schray & Sons; 2nd, Koenig Floral Co. Lily of the valley, Wm. Schray & Sons; Pansies, Geo. B. Windler.

Cut Flowers.

Violets, Wm. Schray & Sons; 2nd, Koenig Floral Co.; Bulbous cut flowers, Wieland & Olinger. Five vases of carnations, Chicago Carnation Co. with Enchantress, Aristocrat, Winsor, White Perfection and Andrew Carnegie; 2nd, Wieland & Olinger; 3rd, James W. Dunford. Fifty light pink carnations, Chicago Carnation Co. with Enchantress; 2nd, J. W. Dunford; 3rd, J. F. Ammann. Fifty white carnations, Chicago Carnation Co. with White Perfection; 2nd, to same firm; 3rd, J. W. Dunford. Fifty dark pink carnations, Chicago Carnation Co. with Aristocrat; 2nd, J. F. Ammann; 3rd, J. W. Dunford. Fifty red carnations, Chicago Carnation Co. with Aristocrat. Fifty carnations, any other color, J. F. Ammann with Rose Pink Enchantress; 2nd, J. W. Dunford with Harlowarden. Four vases of roses, Koenig Floral Co. with Ivory, Richmond, Bride and Bridesmaid; 2nd, F. H. Meinhardt. Twenty-five American Beauties, Koenig Floral Co.; 2nd, Wieland & Olinger. Twenty-five pink roses, J. F. Ammann with Chateaufort; 2nd, Wieland & Olinger. Twenty-five white roses, J. F. Ammann with Ivory; 2nd, Wieland & Olinger with Bride. Twenty-five red roses, J. F. Ammann with Richmond. Lily of the valley, F. H. Meinhardt. Violets, Koenig Floral Co. Floral basket, F. H. Weber. 1st, 2nd, and 3rd. Display of cut flowers in vases, Wm. Schray & Sons; 2nd, Koenig Floral Co.

Peter Reinberg's exhibit intended for competition arrived one day late. The judges were Messrs. R. F. Tesson, Alex Waldbart and Andrew Meyer, Sr. The attendance fell below expectations.

The visitors were entertained by the executive committee at a banquet on Wednesday evening. Among them were: J. S. Wilson, Western Springs, Ill.; Geo. A. Kuhl, Pekin, Ill.; J. F. Ammann and Henry Blexen, Edwardsville, Ill.; H. T. Pyfer and Peter Olsen, Joliet, Ill.; Claude Wiley, Murphysboro, Ill.; A. S. Halsted, Belleville, Ill.; Ed. Easterday, Nokomis, Ill., and A. T. Hey, Springfield, Ill.

The Rochester Commercial Florists' Association was organized recently with Fred W. Vick as president; F. J. Keller, vice-president; Geo. B. Hart, secretary and treasurer. Meetings will be held at 24 Stone Street on the second Monday of each month.

The Bowling Club of the New York Florists Club, has secured accommodations at the Albion alleys, 117 West 23rd St., and a series of practice games will be played every Friday evening. W. E. Marshall is chairman

PLANT IMPORTS.

There were entered at the port of New York during the week of March 11 to March 17, inclusive, the following goods.

From Antwerp: R. F. Lang, 19 cs. plants; Te. Order, 192 tubs shrubs, 3 cs. plants, 2 cs. bulbs; McHutchison & Co., 2 cs. plants.

From Rotterdam: H. F. Darrow, 64 pgs. plants; Wm. Elliott & Sons, 41 cs. do., 13 cs. trees and shrubs; Livingstone Seed Co., 17 cs. trees; P. Ouewerkerk, 71 cs. do.; T. C. Pollock, 27 cs. plants; McHutchison & Co., 148 cs. do., 10 pgs. do., 10 cs. trees; H. & O. Smith, 69 cs. plants; Stumpp & Walter Co., 1 cs. do.; Vaughan's Seed Store, 31 cs. trees, 6 cs. plants; Maltus & Ware, 172 cs. do., 125 pgs. do., 13 cs. trees, 70 cs. plants and roots; Sundry Forwarders, 45 cs. trees, 22 cs. plants, 11 cs. flower roots, 10 bags flower seed.

From Germany: August Rolker & Sons, 3 cs. trees; R. F. Lang, 3 cs. plants; Sundry Forwarders, 4 cs. do.; 27 pgs. do., 6 pgs. flower roots, 1 bals. shrubbery.

Via Southampton: McHutchison & Co., 1 cs. plants; August Rolker & Sons, 9 cs. do.; O. J. Smith, 6 cs. trees; J. M. Thorburn & Co., 13 pgs. garden seeds; sundry forwarders, 5 pgs. trees, 7 cs. bulbs.

The L. L. Olds Co., Clinton, Wis., lost their entire plant by fire on March 5. The loss is placed at \$50,000, partially insured.

Vegetable and Flower **SEEDS**

Reliable and Tested. Catalogue Mailed Free

WEBER & DON

Seed Merchants 114 CHAMBERS STREET NEW YORK

JUST ARRIVED

LARGE SHIPMENT OF

High-Grade SCOTCH SOOT.

We have the Stott Double Nozzle
THOMAS J. GREY CO.
32 & 33 So. Market St., BOSTON

A NEW STRAWBERRY

We have been growing and selling Strawberry Plants in this town over THIRTY YEARS. We introduced Brandywine, Kattie Rice, Sen. Dunlap, Wm. Belt and others of value. Now we are bringing out

THE HIGHLAND

which we expect to take the lead as a Money-Maker. Let us tell you about it and forty others. It will cost you but a postal card.
M. CRAWFORD & CO., Box 1020, Cuyahoga Falls, Ohio

ARE YOU WITH US?

There are still a few good Aster Growers who have not as yet expressed a desire to enter our \$250 00 Prize Aster Growing Contest. Are you among them or are you with us? We want you with us. We will send you a competition card, free for entry. Our Aster Book explains, and remember that as explained in the last issue of Horticulture you need purchase no seed from us unless you see fit; as it is not necessary to enter the contest. But be sure you have seed of the finest kinds. *We sell this class of seed.*

ALTIMO CULTURE CO., = CANFIELD, OHIO

Thorburn's Seeds

COLD STORAGE LILY OF THE VALLEY PIPS

COLD STORAGE LILIUM Harrisii, also SPIRAEA GLADSTONE, LILIUM Auratum, speciosum album, speciosum rubrum, Large Flowering Japan Iris, Cannas, etc.

For prices, state quantities required.

J. M. THORBURN & CO.
33 Barclay St., through to 38 Park Place
NEW YORK

Best Quality Fall Bulbs

It is to your advantage to place your order early. Send us a list of your wants and we will quote you rock-bottom prices. Copy of our Florists' Bulb Catalogue will be sent upon request. Catalogues now ready.

VICK'S SUPERB PANSY SEED

All the best varieties in separate colors
VICK'S SUPERB MIXTURE

the best strain from all the leading named sorts
1-8 oz. 75c. 1-4 oz. \$1.50 Ounce \$5.00

JAMES VICK'S SONS, Rochester, N. Y.

CYCLAMEN

Farquhar's Giant Strain

Unsurpassed for size of flowers.

Giant Crimson Giant Pink
Giant White Finest Mixed
Giant Excelsior, White with
Claret Base

100 seeds, \$1.25; 1000 seeds, \$10.00.

R. & J. FARQUHAR & CO.
6 & 7 So. Market St., Boston, Mass.

QUALITY SEED BULBS

SEND FOR CATALOGUE.

ARTHUR T. BODDINGTON
342 West 14th St., New York.

SUCCESS REWARDED BY SUCCESS—THE UNPRECEDENTED

sale of High Class Aster seed more fully demonstrates the fact that cut flower growers of the better classes, as well as the retail florists from all parts of the United States and Canada, also Europe, are open to conviction that the trade demands a higher and better grade and quality of Asters than has heretofore been produced, consequently our improved chrysanthemum type of Aster Lady Roosevelt seed is in wonderful demand, and not only the seed, but also the cut flower product from this unsurpassed improved variety of Aster as same are being contracted for already for next September delivery by retail florists from several large cities of various parts of the United States, viz: New York, Pittsburg, New Orleans, Denver, &c., at \$1.00 per dozen, net. As we are able to produce this superior Aster Lady Roosevelt by our special improved Scientific Intense Culture Methods with bloom stems 36 in. or more in length enables us to ship the cut flower product to any city in the United States east of Denver without deterioration, as with the large, long, stiff wiry stems they absorb a large quantity of water before shipping, which preserves them in transit, and also two or three weeks after their arrival at their destination.

Marvelous as it may seem, we are expecting this season to improve upon our last seasons accomplishments by growing our Aster plants 6 feet tall, wherein last season they were only 4½ and 5 feet in height, thereby producing bloom stems 36 to 48 inches in length with flowers 4½ to 5½ inches in diameter, thus enabling us to realize net \$4 000 or more, from the one ¼ acre that we intend to grow for the cut flower trade. These will be marketed in at least 40 and possible 60 different cities in the United States, from Boston, Mass., to Denver inclusive. This is our proposed plan for creating a demand and sale for our unparalleled Chrysanthemum type of Aster, Lady Roosevelt for those who may in the near future become producers of this special Aster from the seed they are now purchasing from us. FOR still further desired information send for our illustrated folder—which also contains other very interesting information relative to other special crops we are engaged in the culture of.

CHARLES A. KIBBE,
THE SCIENTIFIC INTENSE CULTURE RANCH, ELMHURST, ILL., Box 344.

BAMBOO CANES TOUGH AND STRONG

6 ft. long—\$1 per 100; \$6 per 1000; \$11 per 2000

They cost about 10 per cent. more than other kinds, and they are 10 times better.

STUMPP & WALTER CO., - 50 Barclay St., New York

BRIDGEMAN'S SEED WAREHOUSE

RICKARDS BROS.

Props:

37 East 19th St., - NEW YORK CITY

BRASLAN SEED GROWERS CO.

GROWERS FOR THE

WHOLESALE TRADE ONLY

SAN JOSE, - - CALIFORNIA

Burpee's Seeds

PHILADELPHIA

Blue List of Wholesale Prices mailed only to those who plant for profit

FISKE SEED CO.

can supply new, fresh seed to the florist for immediate use.

Aster Seed A Specialty

Special Florist List Free

H. E. FISKE SEED CO.
12 & 13 Faneuil Hall Square, BOSTON, MASS.

Look through the Buyers' Directory and Ready Reference Guide. You will find some good offers there also

RELIABLE SEEDS—Sow Now

Primula Obconica Grandiflora

new Hybrids as: Blood-red, Blue, Carmine, Pink, Purple, Violet, Pure-white, Compacta, Gigantea, Fringed Mixed Hybrids, each separate, Tr. Pkt. 50 cents, 6 Tr. Pkts. \$2.50.

O. V. ZANCEN
Seedsman. HOBOKEN, N. J.

C. C. MORSE & CO.

Address all communications to our permanent address
48 to 56 Jackson St., San Francisco, Cal.

The Largest Seed Growers in the United States

BRECK'S SEEDS

For Farmer, Market Gardener and Florist

New Crop High Grade

Catalogues mailed free on application

Joseph Breck & Sons Corp.
47-54 NO. MARKET ST., BOSTON, MASS.

CAULIFLOWER SEED CABBAGE SEED

HJALMAR HARTMANN & CO.,
12 Stormgade,
COPENHAGEN, DENMARK.

VANDA CŒRULEA, The Popular Blue Orchid

ARRIVED in superb condition, a large shipment of this fine Orchid; useful and profitable for cutting as well as for exhibition. Be sure and secure some of these plants now; you will be well pleased with the results. *Write for prices.*

TO ARRIVE. We have large quantities of Orchids of the best kinds on the way, due here about May 1st. If you are in the market for any let us know and we will quote you prices.

Established Orchids. These we have in large quantities to suit all purposes and at low prices.

Supplies—Such as selected Orchid-peat, Live Sphagnum Moss, Orchid-baskets, Books on Orchid Culture, etc., etc.

LAGER & HURRELL, - - - SUMMIT, N. J.

A NEW SOCIETY LAUNCHED.

On Saturday afternoon and evening, between forty and fifty gentlemen lovers of orchids or interested in orchid culture met, pursuant to call, at the hall of the American Institute, New York, to consider the feasibility of and take preliminary steps for the organization of an orchid society of America. Among those present and those from whom approving letters were received, amateur enthusiasts, gardeners and commercial firms were well represented, and the spirit displayed left no room for doubt as to the excellent prospects for the proposed organization. The meeting organized at 7.30 P. M. by the selection of Wm. J. Stewart of Boston as temporary chairman, and Ed Roehrs of Rutherford as temporary secretary. The result of the deliberations was the appointment of a committee of nine on organization to formulate plans and nominate officers and to report at an adjourned meeting, the date of which will be later announced. The committee was constituted as follows: Clement C. Moore, George Schlegel, Dr. Kitchen, J. E. Rothwell, Mrs. Geo. B. Wilson, G. V. Nash, H. A. Siebrecht, Jos. A. Manda and John E. Lager. The exhibition in connection with the meeting continued from 4 till 10 P. M. A few of the more interesting and rare things included in the various groups were as follows:

From Lager & Hurrell, about three dozen species in pots and pans, including *Camerotis purpurea*, a little gem very rare *Dendrobium nobile* Allani-
anum, *Amesianum*, *Cambridgeanum*, and *chryso-discus*, the latter a beautiful little hybrid; *Laelio-Cattleya* C. B. Roeb-
ling, *Cypripedium* Mrs. W. A. Roeb-
ling, and the odd looking *Oncidium fuscum*.

From Julius Roehrs Co., *Cattleya* *Trianae* *alba*, *C. Schroderae* dark lipped varieties, *Cymbidium insigne* a pale pink flower with carmine pencilling on the lip (its first appearance in this country), *Cypripedium* *Leeanum* *Chinkaherryanum*, *Phalaenopsis* *Rimestadiana*

From Clement C. Moore, gardener E. Knight, *Cattleya Schroderae* var. *The Gem*, *C. Sch. Oritani* and several other lovely forms of this glorious orchid and a hybrid between *Cattleya Mendellii* and *Brassavola Digbyana*, a beautiful flower with very large fringed lip. C. G. Roeb-
ling, gardener James Goodier, sent, among other things, a collection of *exypripedium* crosses, in-

cluding *C. X James K. Polk*, *C. X Prewettii*, *C. X W. H. Harrison*, *C. X Germynanum*, *C. X Andrew Jackson*, *C. X Medera superba*, *C. X Sallierii*, *C. X John Tyler*, *C. X Adrastus*, *C. X Patrick O'Mara*, and *C. villosum* *Roeblingianum*, the blue-lipped *Cattleya Trianae* *Roeblingiana*, *Dendrobium Ashburtonianum* and *Devonianum*.

J. A. Manda, *Cypripedium glaucophyllum*, *Williamsii*, *Winneanum*, *media superba* and *Lathamianum aureum* and *Phaio-Calanthe Arnoldiae*.

Carrillo & Baldwin, *Laelio-Cattleya Myra* (*C. Schroderae X Laelia flava*) and *Coelogyne cristata alba*

Seth Borden, gardener F. Varden, *Dendrobium thyrsoiflorum* and other out bloom.

At the meeting of the Dayton (O.) Florists' Club held on March 2, officers were elected as follows: President, H. H. Ritter; vice-president, Mrs. Elizabeth Young; treasurer, George Bartholomew; secretary, H. Frank.

ROBERT CRAIG CO.
ROSES, PALMS,
and Novelties in Decorative Plants
MARKET and 49th STREETS., PHILADELPHIA, PA.

NEPHROLEPIS SCOTTII
in the following sizes, extra good value
25c., 50c., 75c., and \$1
Grand Specimen Plants at \$3, \$4, \$5, \$6.
JOHN SCOTT
Rutland Road and E. 45th St.
Tel. 2800 Bedford **BROOKLYN, N. Y.**

NEP. WHITMANI
2 1/4 in., \$5.00 per 100
NEP. WHITMANI
3 1/2 in., \$25.00 per 100
BOSTON FERNS
2 1/4 in., \$3.00 per 100
H. H. BARROWS & SON Whitman, Mass.

FERNS
Boston, 4 inch 12c, 5 inch 25c.
Plerosonil, 3 inch 8c.
Elegantissima, 2 1/4 inch 6c, 3 inch 10c,
4 inch, 15c.
BAUR FLORAL CO., Erie, Pa.

ORCHIDS
Largest Importers, Exporters, Growers and Hybridists in the World
Sander, St. Albans, England
and 235 Broadway, Room 1
NEW YORK CITY

Imported Orchids
JUST TO HAND
Laelia Purpurata
Cattleya Intermedia
Gattleya Mossiae
JULIUS ROEHRS CO.,
The Orchid Nurseries RUTHERFORD, N. J.

ORCHIDS
We shall receive in about two weeks' time fine importation of *Dendrobium Wardianum*, *D. Phalaenopsis*, *D. Formosum giganteum*.
April: Most all the *Cattleyas*, *Vandas*, *Oncidiums*, etc. Write for Price List.
CARRILLO & BALDWIN, Secaucus, N. J.

ORCHIDS
The largest importation of Orchids ever received in this country **WILL ARRIVE** next spring from Brazil, Colombia and Venezuela. If you intend putting in stock wait for these to arrive and we will quote the Lowest Prices in America.
ORDONEZ BROS., - Madison, N. J.

ORCHIDS for Spring Delivery
NEW IMPORTATIONS
Cattleyas, Laelias, Oncidiums, etc.
WRITE FOR PRICES
Now is the time to Pot Orchids. Best Quality of Peat, Moss and Baskets on hand.
JOSEPH A. MANDA, 191 Valley Road, WEST ORANGE, N. J.

In ordering goods please add "I saw it in HORTICULTURE."

COLD STORAGE
MULTIFLORUM LILY BULBS
7 to 9s
Delivery Immediate or as Ordered. \$45 per 1000
WOOD MOSS, 65c per b'dle.
D. RUSCONI, 128 W. 6th Street, Cincinnati, O.

JAPANESE
THE YOKOHAMA NURSERY CO. LILIES
31 BARCLAY STR. NEW YORK. PLANTS
BAMBOO STAKES



CHOICE SINGLE FLOWERING ENGLISH WALL-FLOWER FOR EASTER BLOOMING

We have an elegant lot of these old-fashioned favorites, field-grown plants, which were potted up into four-inch pots during the latter part of September and which have been carried through the winter in cold frames and are now in prime condition to move. If placed in a carnation house temperature they will come in nicely for Easter, at which time there will be ready sale, at remunerative prices.

Strong, bushy, shapely plants from four-inch pots, \$1.25 per dozen; \$8.00 per 100; \$70.00 per 1000.

HENRY A. DREER, 714 Chestnut St., Philadelphia, Pa.

CHRYSANTHEMUMS

Novelties for 1908 in 2½ inch Pots, Ready for Immediate Shipment

MRS. NORMAN DAVIS. Pure white, an improved Mme. Carnot. Best exhibition white out.
DOROTHY GOLDSMITH. Might be called a bronze F. S. Vallis, and easy doer. The finest bronze out.
KATIE PALGRAVE. A clear, waxy white, resembling Mrs. A. T. Miller, but fuller, and two weeks later
MRS. SOUTHGATE. As large as F. S. Vallis, but a brighter yellow.

O. H. BROOMHEAD. An immense, solid bloom, rich deep rose, with sturdy dwarf habit.
W. MEREDITH. Dark crimson, with gold reverse. An enlarged Edwin Molyneux. A reliable variety.
MARY DONELLAN. A splendid deep yellow.
JOSEPH STONEY. Best exhibition crimson.
HAROLD WELLS. Pure white. A monster.
MRS. J. C. NEIL. Solt canary yellow. An improved Cheltoni.

50c each, \$5.00 per doz., \$35.00 per 100

Also a Large Stock of the Leading Chrysanthemums on Hand. Varieties and Prices on Application.

The New Double Flowering Blue Lobelia **KATHLEEN MALLARD** Ready for Immediate Shipment. 25c each, \$2 50 per doz.

Scott Bros., ELMSFORD NURSERIES, Elmsford, N. Y.

TELEPHONE 474 TARRYTOWN

LLOYD

IS THE REAL THING
The Carnation for every one to grow

LLOYD is a commercial white, with a fancy flower

The only ever-blooming, large-flowering white in existence

Will take the place of all other whites now in commerce. Every New Bedford grower has bought stock. Come and investigate.

**A KEEPER
A SHIPPER
A BLOOMER**

It will bring the shekels when all others fail

\$2 pr 12. \$12 pr 100. \$100 pr 1000

Unrooted Cuttings
\$6 per 100. \$50 per 1000.

H. A. JAHN
NEW BEDFORD, - - MASS.

Carnation Cuttings

Both standard varieties and novelties. Stock guaranteed to be first-class. Address,

S. S. SKIDELSKY

1741 North 18th Street. Philadelphia

ROOTED

CARNATION CUTTINGS

Only the Best Varieties

CHICAGO CARNATION CO., JOLIET ILL.

CARNATIONS ROOTED CUTTINGS

Winona, color, true clear pink, comes nearest to Fiancee but a different type flower. Growth on order of Scott but vastly improved in every respect. Early flowers in quantity and on long stems. Does not burst its calyx. Fine, shapely, active growth. In color and productiveness it is without an equal. Orders booked now and filled in strict rotation. \$12 per 100, \$100 per 1000.

White Perfection, pure white. We have a large stock. \$3 per 100, \$25 per 1000.

F. DORNER & SONS CO.
LA FAYETTE, IND.

JOHN E. HAINES Bethlehem, Pa.

is the place to order rooted-cuttings of the following varieties for 1908.

John E. Haines, red	} Per 100 Per 1000	
Imperial variegated		
Pink Imperial, Pink		\$6.00 \$50.00
Enchantress, Light Pink		

Place your orders early for Jan. delivery.

Single Chrysanthemums ARE THE CRAZE

for the time being.

Are you in line to meet the demand?

I have now ready

KATIE COVELL, ROB ROY, HELEN TOTT, HAROLD BISHOP, MRS. UNTERMEYER, ANNA SPANGLE,

and others, at

\$2.00 per doz., \$15.00 per 100.

I also carry a full line of novelties and standard varieties of

Chrysanthemums, Carnations and Roses

CHAS. H. TOTT, MADISON, N. J.

PRICES QUOTED IN THESE COLUMNS ARE FOR DEALERS ONLY

When Writing to Advertisers Please Mention Horticultur

JOHN BREITMEYER'S SONS

Cor. Miami and Gratiot Aves.
DETROIT, MICH.

Artistic Designs . . .
High Grade Cut Blooms

We cover all Michigan points and good sections of Ohio, Indiana and Canada

William J. Smyth FLORIST

Cor. Michigan Ave. and 31st St., CHICAGO

We ship to all points in Illinois and Iowa.

Phones: Douglas 744, Douglas 523, Douglas 740

M. C. and J. E. HAUSWIRTH

232 Michigan Ave.

CHICAGO

AUDITORIUM ANNEX

Tel. Harrison 585

SAMUEL MURRAY Florist

Coates House Conservatory

1017 BROADWAY, KANSAS CITY, MO

Both 'Phones 2670 Main

FRED C. WEBER FLORIST

4326-28 ST. LOUIS, MO.
OLIVE STREET

Established 1873
Long Distance Phone Bell Lindell 676



GUDE BROS CO
FLORISTS
1214 F. ST. NW
WASHINGTON DC

WASHINGTON,
D. C.

GUDE'S

Geo. H. Cooke FLORIST

Connecticut Avenue and L Street
WASHINGTON, D. C.

The Park Floral Co.

J. A. VALENTINE
Pres.

DENVER, COLORADO

WILLIAM L. ROCK FLOWER CO.

KANSAS CITY, MO.

will carefully execute orders for Kansas City and any town in Missouri or Kansas.

Of Interest to Retail Florists

While counter trade is badly affected by the sudden and very numerous appearance of fakirs a healthy balance is maintained through a large order trade. Stores generally are reporting satisfactory business ahead of last year's returns. The coming of St. Patrick's Day has brought forth many interesting window displays. John Breitmeyer's Sons show some good pot plants of dwarf Japanese peonies. Wm. J. Farrand is cutting some good peony flowers.

WASHINGTON this week, there is not sufficient activity to make life interesting. The glut in the carnation market is depressing in the extreme. Flowers are fine, but persons seem to prefer the spring flowers, for which there is more demand than for any thing else, though the prices of these have dropped. Violets can hardly be disposed of at any price, and the quality is quite poor. Grass in the parks is very green, the trees are already in good bud, and everywhere nature has taken on the tint of resurrection.

OPPORTUNITY FOR A FLORIST.

C. A. Hege, president of the Salem Iron Works, writes as follows: It has occurred to me that some of your readers, who are florists, might be glad to know of a good opening for a florist in the south. I believe here in Winston Salem is such an opening, as our town of Winston Salem, N. C., has about 25,000 population and no regular florist. There are two amateur florists here, who might do something if they understood the business. Nearly all the flowers used for floral designs have to be ordered from outside. If you care to mention these facts in your paper I will gladly answer any inquiries relative to same.

NEW RETAIL FLOWER STORES.

Leeb & Co., 370 Minnesota St., St. Paul, Minn.

John Walker, W. Federal St., Youngstown, O.

Mann & Brown, branch store in Jefferson Hotel, Richmond, Va.

INCORPORATED.

Van Praag Florist Co., New York; M. Van Praag, E. McInness, J. F. Carroll; capital, \$500.

NEWS NOTES.

A. M. Gilbert has started as a florist and market gardener in Middletown, N. Y.

Fire starting in the basement of T. F. Keller's flower store, Providence, R. I., on March 11, caused considerable loss to stock and fixtures.

The son and daughter of the late J. L. Watkins will continue his business at Sandy Hill, N. Y., under the firm name of J. L. Watkins & Son.

Windland & Keimel are starting in as wholesale growers at Elmhurst, Ill. Mr. Keimel was formerly with Poehlmann Bros. W. McGovern of New Jersey succeeds him with the Poehlmanns

Florists Out of Town

Taking orders for delivery in
New York or Vicinity
can have them filled in best
manner and specially delivered by

Thomas Young, Jr.

500 Fifth Ave., New York City
Telephone 847 Bryant.

ALEX. McCONNELL

571 FIFTH AVENUE
NEW YORK CITY

Telegraphic orders forwarded to any part of the United States, Canada, and all principal cities of Europe. Orders transferred or intrusted by the trade to our selection for delivery on steamships or elsewhere receive special attention.

Telephone Calls, 487 and 488 38th St.
Cable Address, ALEXCONNELL

WILLIAM H. DONOHUE

FLORAL DECORATOR

17 East 28th St., New York

Special Attention to Theatre
and Steamer Orders, and reliable
deliveries guaranteed.

DAVID CLARKE'S SONS

Deliver orders from any part of the country to
New York City

Or OUT-GOING STEAMERS

Write or telegraph

2139-2141 Broadway, New York
Telephone 1552-1553 Columbus

M. A. BOWE

In the Heart of New York City

1294 Broadway

Tel. 2270, 38th St. NEW YORK
Our Motto -- The Golden Rule.

YOUNG & NUGENT

42 West 28 St., NEW YORK

"FLOWERS BY TELEGRAPH"

Flower Deliveries

In Brooklyn and other Long Island Points
New York City, New Jersey, etc. At Theatres,
Hotels, Steamers or Residence.

WILSON

Fulton St. and Greene Ave., Brooklyn, N. Y.

ALBANY, N. Y.

EYRES

Flowers or Design Work

DELIVERED IN ALBANY AND VICINITY
ON TELEGRAPHIC ORDER.

11 NORTH PEARL ST., ALBANY, N. Y.

JACOB SCHULZ, 644 Fourth Ave.,
LOUISVILLE, KY.

Cut Flowers of BEST QUALITY in season
delivered promptly to any address.

Write, Telegraph or Telephone.
Cumberland and Home Phones 223 and 984

INDISPENSABLE

EVERY FLORIST NEEDS IT

EVERLASTING

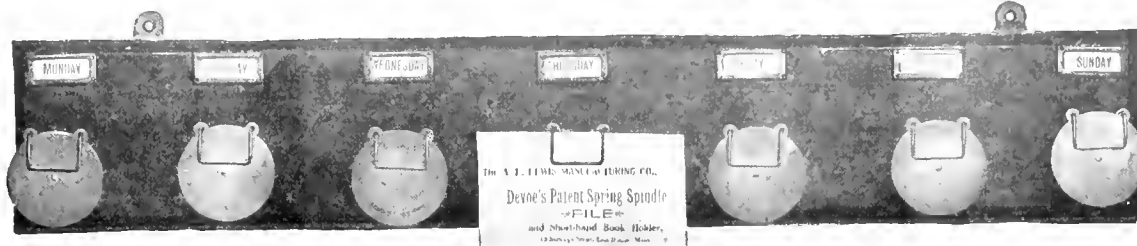

LEWIS'S WEEKLY BOARD FILE

takes the place of Memo, or Order Books, also a line of nails or of the old fashioned Spike Spindle Sets, from both of which it takes time to remove all but the top paper. Just the thing and the latest device for sale slips, orders to be filled, this week's daily engagements, and a reminder of next week's. The board File is made up of sets of our Devoe Patent Spring Spindle File. The board is of polished Golden Oak, 10 x 5 inches, with brass name plates in which are the days of the week neatly printed. Can remove days of week and place Salesman's name in for cashier's desk. Its good points are that it is Cheap, Ornamental, a Time Saver, makes no holes in the paper, cannot injure operator or customer. PRICE: Set of 7 on a Board, or Florists' use, \$2.00; set of 6 on a Board (omitting Su day), \$1.75. Devoe's Spring Spindle Paper File, Typewriters' Note Book, Hat and Reading Book Holder, comes in Mission Green, Mission Black, Polished Golden Oak base, and is the only perfect Spindle File, best and cheapest Note Book Holder. While in use any Paper can be changed or displaced without removing "Memo", Sale Slip, Copy Lists, Etc. SINGLE FILE, 4 in 1, postpaid 25 cts. Wanted - Florist Supply Houses to Handle. State Rights For Sale. THE A. F. LEWIS MFG. CO., E. BOSTON, MASS.

PROMPT DELIVERY IN BOSTON

AND ALL NEW ENGLAND POINTS HOUGHTON & CLARK 396 Boylston St., Boston, Mass.



BOSTON'S BEST In Quality and Design

Can be relied upon when you transfer your retail orders to

EDWARD MACMULKIN 194 Boylston Street, Boston

Send flower orders for delivery in

BOSTON

and all

NEW ENGLAND POINTS THOS. F. GALVIN 124 Tremont St., Boston

TRANSFER

Your orders for flower or plant delivery in Eastern New England to

JULIUS A. ZINN, 2 Beacon St., Boston. Fine Design Work a Specialty.

Prices quoted in these columns are for Dealers Only. When writing to Advertisers Please Mention HORTICULTURE.

YALE Orders for flower deliveries to Yale College and all other Connecticut points carefully filled and delivered by

J. N. CHAMPION & COMPANY 1026 CHAPEL STREET NEW HAVEN, CONN.

ATLANTA FLORAL CO. 41 Peachtree Street, ATLANTA GEORGIA.

HART'S HANDY HANDLE

"At Easter-time, with a little chiffon decoration, and the Handle, we were able to increase the value of plants from 50% to 100%." - H. E. WILSON.

Write for descriptive circular and prices

GEO. B. HART, 24 Stone St., Rochester, N. Y.

NEWS NOTES.

The plans of the Spokane Nursery Co., Spokane, Wash., for its plant on the North Side include fireproof concrete buildings, some 23,000 square feet under glass, and private water system, to be completed at an expense of \$50,000. J. H. Mumm is president of the company.

J. T. Withers, landscape gardener and forester from Jersey City, is giving a series of lectures under the auspices of the Twin Cities Florists' and Gardeners' Club and the different improvement societies. So far the lectures have been well attended, and a lot of interest is shown. Mr. Withers speaks very highly of the great possibilities in park work and street tree planting in Minneapolis.

The board file advertised in this issue fills a long-felt want in the daily office and order department of the wholesale or retail florist. Among the firms already using these inexpensive time and labor savers are Thos. F. Galvin, Henry M. Robinson & Co., S. Hoffman and N. F. McCarthy & Co., Boston; A. H. Hews' Pottery, North Cambridge; R. Armstrong Natick; W. W. Edgar Co., Waverley; Mann Bros., Randolph; Thos. Roland Nahant, and many others, all of whom regard them as indispensable.

The "Japana" Cut Flower Holder

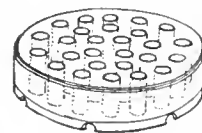

A handy article for florists. Sells to the trade on sight. Made of glass in three sizes. The "Anglais" Table Decoration, something entirely new, long needed. The florist and housewife will appreciate this article, as it simplifies the art of table decorating.

Ask for catalog.

M. V. GARNSEY, Dept. M, 130 Walola Ave., La Grange, Ill.

BOSTON FLORIST LETTER CO. Manufacturers of FLORISTS' LETTERS

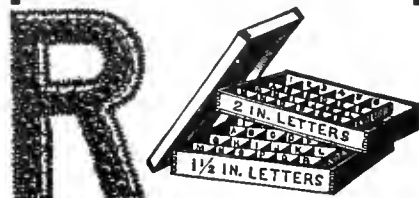

This wooden box nicely stained and varnished, 18x30x12, made in two sections, one for each size letter, given away with first order of 500 letters

Block Letters, 1 1/2 or 2 inch size per 100, \$2. Script Letters, 3. Fastener with each letter or word. Used by leading florists everywhere and for sale by all wholesale florists and supply dealers

N. F. MCCARTHY, Manager 66 Pearl Street, BOSTON, MASS.

Large Plants, Bay and Box trees, Palms, Hydrangeas, Agaves, etc., will soon need re-potting. Use the Mission Plant Box if you want the most durable and appropriate box made. Very reasonable in price. Made of pine or cypress.

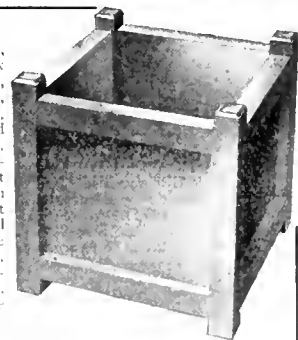

Write for Prices.

Wagner Park Conservatories SIDNEY, OHIO.

KORAL SCRIPT LETTERS AND EMBLEMS

ONCE USED ALWAYS USED Forsale by at firstclasssupplyhouses. Made by

KORAL MFG. CO. 26 Hawley St., Boston

American Beauty Roses
 Orders in any quantity promptly filled. All grades.
Acacia pubescens
 Sprays of this popular golden spring beauty in regular daily shipments, \$1.50 and \$2.00 per bunch.

The Leo Niessen Company
 1209 Arch St., Philadelphia, Pa.
 Open from 7 a. m. to 8 p. m.

VALLEY
The BEST
\$3.00 per 100
 New buyers always come again. Superior quality counts.

S. S. PENNOCK - MEEHAN CO.
 1608-1620 Ludlow St. PHILADELPHIA
 "The" Wholesale Florists of Philadelphia

EVERYTHING SEASONABLE IN
CUT FLOWERS
EDWARD REID, Wholesale Florist
 1526 Ranstead St., PHILADELPHIA
 STORE CLOSES 8 P. M.

CHAS. W. MCKELLAR
 51 WABASH AVE., CHICAGO
 Western Headquarters for Choice Orchids
 Valley, Roses and all Cut Flowers

PETER REINBERG
 WHOLESALE
CUT FLOWERS
 51 Wabash Av., Chicago, Ill.
 In writing advertisers, mention Horticulture

CUT FLOWER BOXES
EDWARDS FOLDING BOX CO
 MANUFACTURERS
 PHILADELPHIA, PA.

AMERICAN BEAUTY and all other ROSES
LILY OF THE VALLEY, CARNATIONS
WELCH BROS., 226 Devonshire St., Boston, Mass.

GIANT DAISIES
YELLOW and WHITE IN QUANTITY
W. E. MCKISSICK WHOLESALE FLORIST
 PHILADELPHIA
 1619-1621 RANSTEAD ST.

DAILY CONSIGNMENTS
 From 40 to 60 Growers
 We can care for your cutflower wants to advantage.
E. F. WINTERSON CO.
 45-47-49 WABASH AVE., CHICAGO

Rice Brothers
 115 N. 6th Street, MINNEAPOLIS, MINN.
WHOLESALE FLORISTS and SUPPLIES
 CUT FLOWERS received twice daily, and can fill your orders to your satisfaction. A complete line of Hardy Greens—WILD SMILAX, BOXWOOD, HARDY FANCY FERNS, GALAX LEAVES.
 Write for quotations on large quantities.

WHOLESALE FLOWER MARKETS—TRADE PRICES—Per 100 TO DEALERS ONLY

	CHICAGO March 16	TWIN CITIES March 16	PHILA. March 16	BOSTON March 16
ROSES				
Am. Beauty, Fancy and Special...	30.00 to 35.00	45.00 to 60.00	12.50 to 25.00	20.00 to 25.00
" Extra.....	15.00 to 20.00	30.00 to 40.00	10.00 to 12.50	15.00 to 20.00
" No. 1.....	6.00 to 8.00	15.00 to 25.00	8.00 to 10.00	8.00 to 10.00
" Lower grades.....	4.00 to 6.00	10.00 to 15.00	1.00 to 4.00	4.00 to 6.00
Bride, "Maid, Fancy & Special....	0.00 to 8.00	8.00 to 10.00	8.00 to 10.00	6.00 to 8.00
" Extra and No. 1..... to 4.00	6.00 to 8.00	4.00 to 6.00	3.00 to 5.00
" Lower grades.....	1.50 to 2.00	3.00 to 4.00	1.00 to 3.00	1.00 to 2.00
Killarney, Richmond, Fan. & Sp....	6.00 to 8.00	8.00 to 10.00	6.00 to 10.00	8.00 to 10.00
" Lower grades.....	3.00 to 4.00	3.00 to 6.00	1.00 to 3.00	2.00 to 6.00
Chatenay, Wellesley, Fan. & Sp....	6.00 to 8.00	8.00 to 10.00 to	4.00 to 8.00
" Lower grades.....	2.00 to 4.00	3.00 to 6.00 to	1.00 to 3.00
Golden Gate, Ivory.....	4.00 to 8.00	5.00 to 8.00	2.00 to 6.00	1.00 to 6.00
CARNATIONS				
Fancy and Novelties.....	1.50 to 3.00	2.50 to 3.50	2.00 to 4.00	1.00 to 2.00
Ordinary.....	1.00 to 2.00	1.50 to 2.00	.50 to 1.50	.50 to .75
MISCELLANEOUS				
Violets.....	.30 to .50	.50 to 1.00	.25 to .75	.25 to .50
Cattleyas.....	40.00 to 50.00 to 50.00 to 50.00	50.00 to 60.00
Cypridinms.....	12.00 to 15.00	12.00 to 15.00	10.00 to 15.00	8.00 to 10.00
Lilies.....	8.00 to 12.00	10.00 to 15.00	8.00 to 12.50	8.00 to 10.00
Lily of the Valley.....	2.00 to 3.00	2.00 to 3.50	2.00 to 3.00	2.00 to 3.00
Freesia.....	2.00 to 3.00	1.50 to 3.00	1.00 to 2.00	1.00 to 2.00
Rom. & Hy., Paper White Nar.....	2.00 to 3.00	2.00 to 3.00	1.00 to 2.00	1.00 to 2.00
Daffodils.....	2.00 to 2.50	2.00 to 2.50	1.00 to 3.00	1.00 to 2.00
Tulips.....	2.00 to 3.00	2.00 to 2.50	2.00 to 4.00	1.00 to 3.00
Mignonette.....	2.00 to 4.00	4.00 to 6.00	2.00 to 4.00	3.00 to 4.00
Garden as.....	40.00 to 50.00	35.00 to 50.00	10.00 to 25.00	25.00 to 40.00
Lilac per bunch.....	1.00 to 1.50	1.00 to 1.50	.50 to 1.50	1.00 to 1.50
Sweet Peas.....	.75 to 1.00 to 1.00	.25 to .75	.50 to 1.00
Adiantum.....	.50 to 1.00	.75 to 1.00	1.00 to	1.00 to 1.50
Whitmanii Fronds..... to to	2.00 to	2.00 to 3.00
Smilax.....	10.00 to 12.00	12.00 to 15.00	15.00 to	10.00 to 12.00
Asparagus Plumosus, strings.....	35.00 to 50.00	35.00 to 50.00 to 50.00	25.00 to 50.00
" " & Spreo. (100 bchs.)	25.00 to 35.00	35.00 to 40.00 to 50.00	15.00 to 50.00

THE FLORISTS' SUPPLY HOUSE OF AMERICA

Without a rival in knowledge of the requirements of the trade and the ability to supply them. Our New Illustrated Catalogue, recognized as a work of art unprecedented in its line for variety, novelty and completeness, tells the story fully, and if you have not yet sent for it, do so now.

'TIS FREE TO EVERYBODY IN THE TRADE

H. BAYERSDORFER & CO., 1129 Arch St., Philadelphia, Pa.

FLOWER MARKET REPORTS

BOSTON The present week opened with a fair activity which augured well for the week's business, but it was short-lived and the past three days are in no respect an improvement on the conditions reported last week. All crops are in full tide and the demand is insufficient to move the accumulation. It looks like a heavy load on an uphill road until Easter comes, after which better things may, perhaps, be hoped for. There is no shortage of any staple but all are of the finest quality and finish. The trouble lies entirely in the demand and consumption.

BUFFALO Conditions have changed but little during the past week, as all kinds of stock are getting more plentiful daily with a consequent lowering of prices all along the line, but even had the supply been in moderate offerings it is doubtful if it would have resulted in injecting the needed activity into the trade, shipping trade being light and speculative trading almost eliminated. Carnations are in their flush and the quality has not been equaled this season. The bargain signs read, "today only," but are seen the day after in the same place. It is to be hoped that the coming week may see an improvement in the conditions which have prevailed in the cut flower market so far in the Lenten season.

CHICAGO Business fair with plenty of stock. Beauties more plentiful and other roses at their best. Carnations are beginning to shorten up a little, which means better prices. For the past few days, the number of white carnations bought by Chicago retailers for the purpose of coloring green is surprising. They do not stop at carnations, white roses and lilies being given the same treatment in honor (?) of St. Patrick's Day. Bulbous stock, including lilies, is still very plentiful. Single violets are coming in fine shape and are preferred to New York doubles, which are beginning to shake a little now. With the rose show only a few days off it is pleasing to notice the fine stock that is being cut by some of the prospective competitors for prizes; with good weather it is expected to have the largest and best rose show ever given by the American Rose Society.

NEW YORK. The remark of one wholesaler that he expected to be obliged to begin giving green trading stamps with every flower sale doesn't seem a bit preposterous after one has made the circuit of the wholesale flower market and marveled at the inexhaustible supplies pouring in from all directions and sympathized with the dealer in his inability to move more than a small fraction of the accumulation in any legitimate manner. The rose is now in the same plight which the carnation has had to face for some weeks past and all semblance of standard values for anything in this line has disappeared. The prediction is made that the carnation market will presently see a decided improvement. We hope the near future will

prove the forecaster to have been right in his prediction. Such excellence of quality as is in evidence on all sides merits a better return.

PHILADELPHIA The volume of business was fully maintained last week, but prices rule lower if anything. Carnations have never been so plentiful at this season. American Beauty and other roses are more plentiful and have sustained a serious drop in quotations. Liberty is of fair quality but takes a back seat as compared to Richmond, both in the price and the demand. Violets are more plentiful, the cold frame growers being now in. Lilies, tulips and daffodils are in fair demand and now rank above the carnation as a paying crop. Snapdragons are more plentiful and being well received. A slight improvement is noticeable in the sweet pea market, and the quality is, in general, very choice; orchids normal. The greens market is rather unsatisfactory. A good many shamrocks were sold but many more were given away by the dry-goods men. One department store distributed forty thousand small pots gratis as an advertisement.

TWIN CITIES We are glad to report good business with steady prices. Roses in best grades are still scarce, while the others are plentiful now. Bulbous stock and violets crowded the market somewhat at the beginning of the month, but at present there is just about enough to supply the demand.

PHILADELPHIA NOTES.

Green carnations, green tulips, green roses, green everything on St. Patrick's Day in Philadelphia! The trouble is, these monstrosities were in demand, and traders had neither soul nor sentiment beyond the dollar. Will dirty deformities sell—overboard goes every little spark of celestial fire these traders may have possessed! We regret to have to report this from the home of the Pennsylvania Horticultural Society and the "Pioneer" Florists' Club of America. Shades of Bartram, McMahon, Buist and Meehan!

Wm. Kleinheinz says in regard to snapdragons that plants from cuttings are two weeks later than from seed and offer no advantage to offset. Back to seedlings again next year. Mrs. Morgan is a rose he could not do without under any consideration. Golden Gate and Uncle John also fine. Jno. H. Dodd's superintendent at the Wanamaker estate is also a believer in Uncle John and is trying what is said to be an improved Uncle John: Souvenir de Pere Notting.

Samuel Batchelor is highly pleased

E. A. BEAVEN
Southern Wild Smilax,
Log Mosses,
 Natural and Perpetuated — at Wholesale.
EVERGREEN, ALABAMA.

H. J. Smith
HARDY CUT FERN
DEALER, ETC.,
 Write for Prices
HINSDALE, MASS.

Alex Mann, Jr. Co., Inc.
 Wholesale Dealer in
Florists' Supplies and Cut Flowers
 White Doves, \$9.00 per doz.
 Galax Leaves.
 1125 Polk Street, San Francisco, Cal.

J. B. Murdoch & Co.
 Wholesale Florists
FLORISTS' SUPPLIES
 714 Penn Ave., PITTSBURG, PA.
 Long Distance Phone 1435 Court.

ROBERT J. DYSART,
Public Accountant and Auditor
 Simple methods of correct accounting especially adapted for florists' use.
Books Balanced and Adjusted
 Merchants Bank Building
28 STATE ST., BOSTON
 Telephone, Main 58.

The KERVAN CO. 113 W. 28th St. New York
WHOLESALE DEALERS
 Fresh cut Palmetto & Cycas Palm Leaves, Galax, Leucothoe, Ferns and Mosses. All Decorating Evergreen.

with the new geranium Snowdrop. It is a single of the purest snow white, perfect in form, large in truss and flower. Another fine novelty to be seen at this place just now is Bougainvillea laurietia, one of Veitch's introductions.

BUSINESS CHANGES.

William Stewart of Mt. Vernon, N. Y., has purchased the greenhouse of Walter Slade, Franklin, Mass.

A new wholesale plant and flower commission establishment has been opened at 50 W. 29th St., New York, by E. H. Smith. Jas. H. Blanvelt is manager. Mr. Smith has a greenhouse establishment at Hazleton, Pa.

1000 Strings of Smilax
MUST BE SOLD BEFORE EASTER

Strings 6 feet long. 15 cents each.

Let me send sample lot.

VERN L. SCHLURAFF, - - - ERIE, PA.

JOHN YOUNG
WHOLESALE FLORIST
 Finest American Beauties and Carnations
 51 West 28 St. - NEW YORK

FORD BROTHERS
 48 West 28th Street, NEW YORK
FINE ROSES FANCY CARNATIONS
 A Full Line of All CUT FLOWERS
 Telephone, 3870 or 3871 Madison Square

H. E. FROMENT,
 Wholesale Commission Florist,
 Choice Cut Flowers,
 57 West 28th St., :: NEW YORK.
 Telephones: 2200, 2201, Madison Square.

The Reliable Commission House
 Richmond Roses and Rich Flowers
 of all varieties
JOS. S. FENRICH
 110 W. 28th Street, New York
 Tel. 324-325 Madison Square

Established 1891 BUY FROM SHIP TO TRY **ME**
ALFRED H. LANGJAHR
 All Choice Cut Flowers In Season
 55 West 28th St., New York
 telephone 3924 Madison Square.

JOHN I. RAYNOR
Wholesale Commission Florist SELLING AGENT FOR LARGEST GROWERS
 A full line of Choice Cut Flower stock for all purposes. Comprises every variety grown for New York market, at current prices
 TEL. 1998 MADISON SQUARE 49 W. 28 St., New York City

Walter F. Sheridan
 Wholesale Commission Dealer in
CHOICE CUT FLOWERS
 39 West 28th Street, New York
 Telephone: 3532-3533 Madison Square

HEADQUARTERS FOR NOVELTIES
ORCHIDS A SPECIALTY
 THE HIGHEST GRADE OF **VALLEY** ALWAYS ON HAND
 GARDENIAS, DAISIES, ROSES AND CARNATIONS
 Telephone
JAMES McMANUS, 759 Mad. Sq. 42 W. 28th St., New York

PHILIP F. KESSLER 55 & 57 W. 26th St., New York City
 Commission Dealer, Wholesale Buyer and Seller of
 Open from 5 a. m. to 6 p. m. Sunday till 10 a. m.
CUT FLOWERS
 Tel., 5243 and 2921 Madison Sq. Res., 345 J., Newtown.
Finest Lilies in the Market Every Day in the Year.

WHOLESALE COMMISSION FLORIST **J. K. ALLEN** 106 W. 28 ST. NEW YORK
 Telephone 167 Madison Sq.
 OPEN 6 A. M. DAILY
 We have a good regular outlet for seasonable flowers

NEW YORK QUOTATIONS PER 100—TO DEALERS ONLY

	Last Half of Week ending Mar. 14 1908	First Half of Week beginning Mar. 16 1908	Last Half of Week ending Mar. 14 1908	First Half of Week beginning Mar. 16 1908
Roses				
Am. Beauty, fan and sp.	10.00 to 15.00	10.00 to 15.00	40.00 to 50.00	40.00 to 50.00
" extra	5.00 to 8.00	5.00 to 8.00	8.00 to 10.00	8.00 to 10.00
" No. 1	3.00 to 5.00	3.00 to 5.00	8.00 to 10.00	8.00 to 10.00
" Lower grades	1.00 to 1.00	1.00 to 1.00	1.00 to 2.00	1.00 to 2.00
Bride, 'Maid, fan and sp.	4.00 to 8.00	4.00 to 8.00	1.00 to 1.50	1.00 to 1.50
" " extra	2.00 to 3.00	2.00 to 3.00	1.00 to 1.00	1.00 to 1.00
" " lwr. gids.	1.00 to 1.00	1.00 to 1.00	1.00 to 1.00	1.00 to 1.00
Killimey, Richmond, fancy & spec	6.00 to 10.00	6.00 to 10.00	1.00 to 1.00	1.00 to 1.00
" " lower grades	2.00 to 4.00	2.00 to 4.00	2.00 to 4.00	2.00 to 4.00
Chatenay, Wellesley, fan, and spec.	6.00 to 8.00	6.00 to 8.00	25.00 to 40.00	25.00 to 40.00
" " lower grades	1.00 to 4.00	1.00 to 4.00	1.00 to .75	1.00 to .75
Golden Gate, Ivory	1.00 to 6.00	1.00 to 6.00	.50 to .60	.50 to .60
Carnations, Fancy and Novelties.	1.00 to 2.00	1.00 to 2.00	.75 to 1.50	.75 to 1.50
" Ordinary50 to .75	.50 to .75	8.00 to 12.00	8.00 to 12.00
Violets20 to .30	.20 to .30	25.00 to 35.00	25.00 to 35.00
			10.00 to 10.00	10.00 to 10.00

B. S. SLINN, Jr.
 —WHOLESALE FLORIST—
 55 & 57 W. 26th St., New York City
 Tel., 3864 Madison Sq. Shipping Orders Solicited.
VIOLETS Roses and Carnations

Edward C. Horan
Wholesale Florist
 55 WEST 28th ST.
 Tel. 1462 Madison Square New York
 1463

TRAENDLY & SCHENCK
WHOLESALE FLORISTS
 Furnish best stock at fair prices all the year round Send for quotations on fall orders
 Tel. 798.799 Madleon Sq. 44 West 28th Street, New York City

Alexander J. Guttman
THE WHOLESALE FLORIST OF NEW YORK
 43 WEST 28th STREET
 PHONES. 1664--1665 MADISON SQUARE
ENOUGH SAID

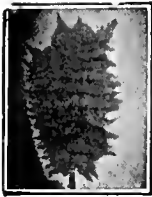

HARDY CUT FERNS

Sphagnum Moss, Extra Large Bales, per bale, \$1.25. Fancy and Dagger Ferns our speciality. A trial order will convince you that we ship only first-class stock. Headquarters for Florists' supplies and wire work. All cut flowers in season. **BOXWOOD**, per bunch 35c, 50 lbs. \$7.50.

MICHIGAN CUT FLOWER EXCHANGE, INC., All 'phone connections 38-40 Broadway, Detroit, Mich.

FANCY and DAGGER

Extra fine, \$1.75 per 1000. Bronze and Green Galax, \$1.25 per 1000. Leucothoe Sprays, \$1.00 per 100, \$7.50 per 1000.

Headquarters in Western New York
FOR
ROSES, CARNATIONS
And all kinds of Seasonable Flowers
Wm. F. Kasting Co.
Wholesale Commission Florist, also Dealer in
Florists' Supplies and Wire Designs.
383-87 ELLICOTT ST.
BUFFALO, N. Y.
Give us a trial. We can please you.

FRANK S. HICKS & CO.
Wholesale Florists.
Open Now for Consignments of Cut Flowers.
52 West 28th Street, - New York City
Tel. 2920 Mad. Sq.

FRANK MILLANG
Wholesale Florist
Telegraphic Orders Filled and Delivered.
55-57 West 26th St., New York City.

HENRY M. ROBINSON & CO.
Wholesale and Commission
— FLORISTS —
Hardy Cut Evergreens and Florists' Supplies
15 Province St. and 9 Chapman Place,
BOSTON, MASS.

Flowers and
Florists' Supplies
The best place in AMERICA to buy
BAY TREES
N. F. McCarthy & Co.
84 Hawley St., BOSTON, MASS.
Large & Dealers in Supplies in New England.

WHOLESALE FLOWER MARKETS. — TO DEALERS ONLY. PER 100.

	CINCINNATI March 16	DETROIT March 16	BUFFALO March 16	PITTSBURG March 16
ROSES				
Am. Beauty, Fan, and Sp.	25.00 to 30.00	15.00 to 25.00	23.00 to 35.00	20.00 to 25.00
“ Extra	10.00 to 15.00	10.00 to 15.00	15.00 to 20.00	10.00 to 15.00
“ No. 1	5.00 to 6.00	4.00 to 8.00	5.00 to 10.00	4.00 to 6.00
“ Lower grades	6.00 to 8.00	6.00 to 8.00	6.00 to 10.00	5.00 to 6.00
Bride, "Maid, F. & S.	3.00 to 5.00	3.00 to 4.00	3.00 to 4.00	2.00 to 4.00
“ Extra	6.00 to 8.00	6.00 to 10.00	6.00 to 10.00	5.00 to 10.00
“ Lower grades	4.00 to 6.00	3.00 to 4.00	3.00 to 6.00	4.00 to 5.00
Killarney, Richmond, Fan, & Sp.	6.00 to 8.00	6.00 to 10.00	6.00 to 10.00	5.00 to 10.00
“ Lower grades	4.00 to 6.00	3.00 to 4.00	3.00 to 6.00	4.00 to 5.00
Chateaux, Wellesley, Fan, & Sp.	6.00 to 8.00	6.00 to 10.00	6.00 to 10.00	5.00 to 10.00
“ Lower grades	4.00 to 6.00	3.00 to 4.00	3.00 to 6.00	4.00 to 5.00
Golden Gate, Ivory	5.00 to 6.00	3.00 to 4.00	3.00 to 6.00	4.00 to 5.00
CARNATIONS				
Fancy and Novelties	3.00 to 3.00	2.00 to 3.00	2.00 to 3.00	2.00 to 3.00
Ordinary	1.00 to 2.00	1.00 to 1.50	1.00 to 2.00	1.00 to 1.00
MISCELLANEOUS				
Violets	50 to .75	.75 to 1.00	.40 to .75	.25 to .75
Cattleyas	40.00 to 50.00	35.00 to 50.00	40.00 to 60.00	30.00 to 75.00
Cypripediums	12.00 to 15.00	12.00 to 15.00	10.00 to 15.00	10.00 to 15.00
Lilies	10.00 to 12.50	12.50 to 15.00	4.00 to 15.00	12.50 to 15.00
Lily of the Valley	3.00 to 4.00	2.00 to 4.00	2.00 to 4.00	3.00 to 4.00
Freesia	3.00 to 4.00	3.00 to 4.00	1.00 to 3.00	1.00 to 3.00
Roman Hy., Paper White Nar.	2.00 to 3.00	2.00 to 3.00	2.00 to 3.00	1.00 to 3.00
Daffodils	2.00 to 3.00	2.00 to 3.00	2.00 to 3.00	2.00 to 3.00
Tulips	2.00 to 4.00	2.00 to 3.00	2.00 to 3.00	2.00 to 4.00
Mignonette	6.00 to 8.00	4.00 to 8.00	2.00 to 5.00	3.00 to 5.00
Gardenias	35.00 to 50.00	35.00 to 50.00	35.00 to 40.00	30.00 to 40.00
Lilac per bunch	1.00 to 1.50	1.00 to 1.50	.50 to 1.00	1.00 to 1.00
Sweet Peas	.50 to 1.00	.50 to 1.50	.40 to 1.00	.75 to 1.00
Adiantum	1.00 to 1.00	.75 to 1.25	.50 to 1.00	1.00 to 1.25
Whitmanii Fronds	1.00 to 1.00	1.00 to 1.00	8.00 to 10.00	10.00 to 10.00
Smilax	12.00 to 12.00	10.00 to 15.00	10.00 to 15.00	10.00 to 15.00
Asparagus Plumosus, strings	40.00 to 50.00	35.00 to 50.00	40.00 to 60.00	25.00 to 50.00
“ & Spren (100 bchs.)	25.00 to 35.00	25.00 to 30.00	25.00 to 50.00	30.00 to 50.00

SAMUEL A. WOODROW
WHOLESALE PLANTSMAN
Palms, Large and Small Ferns, etc.
53 West 30th Street, NEW YORK
Telephone 2083 Madison

WILLIAM H. KUEBLER
Brooklyn's Foremost and Best
WHOLESALE COMMISSION HOUSE
A First Class Market for all CUT FLOWERS
28 Willoughby St., Brooklyn, N. Y.
Tel. 4591 Main

CLEARY'S HORTICULTURAL CO.
Management AMBROSE T. CLEARY
Wholesale Contracting, Jobbing, Auction
HORTICULTURAL PRODUCTS
of every description.
Consignments Received. Surplus Stock Converted.
62 Vesey St., NEW YORK

Moore, Hentz & Nash,
Wholesale Commission Florists,
55 and 57 West 26th Street,
Telephone No. 756
Madison Square. **New York.**

H. C. BERNING
Wholesale Florist
1402 Pine Street, ST. LOUIS, MO.

MILLANG BROS.
WHOLESALE COMMISSION FLORISTS
41 West 28th Street
Telephone 3860
3861 Madison **NEW YORK**

A. MOLTZ
Will purchase flowers on order in
N. Y. market and ship carefully at
prevailing wholesale prices. Address
55-57 West 26th Street, New York City

REED & KELLER
122 West 25th St., New York
Florists' Supplies
We manufacture all our
Metal Designs, Baskets, Wire Work & Novelties
and are dealers to
Glassware Decorative Greens and Florists' Requisites

In writing to Advertisers kindly mention Horticulture

Buyer's Directory and Ready Reference Guide

Advertisements under this head, one cent a word. Initials count as words.

Regular advertisers in this issue are also listed under this classification without charge. Reference to List of Advertisers will indicate the respective pages.

Buyers failing to find what they want in this list will confer a favor by writing us and we will try to put them in communication with reliable dealers.

ACCOUNTANT

R. J. Dysart, 23 State St., Boston.
For page see List of Advertisers.

ALTERNANTHERAS

Red Alternantheras at 40 cents per 100.
C. W. Moeckel, 17 Summer St., Fitchburg, Mass.

ARAUCARIAS

Godfrey Aschmann, 1012 Ontario St., Philadelphia, Pa.
For page see List of Advertisers.

ASPARAGUS

A. N. Pierson, Cromwell, Conn.
Asparagus Plumosus Seedlings.
For page see List of Advertisers.
Asparagus plumosus and Spreuzeri, 2-in., strong, \$2.00 per 100. J. H. Dann & Sob, Westfield, N. Y.

Asparagus Plumosa, 2 in. pots. Fine plants, \$3.00 per 100; \$25.00 per 1000. Cash with order or good reference. Erie Floral Co., Erie, Pa.; or, Wm. F. Kastling Co., 385 Elliott St., Buffalo, N. Y.

ASTERS.

Charles A. Kilbce, Elmhurst, Ill.
Aster Lady Roosevelt.
For page see List of Advertisers.

AUCTION SALES

Cleary's Horticultural Co., 62 Vesey St., New York.
Horticultural Products of Every Description.
For page see List of Advertisers.
The Fruit Auction Co., 200-204 Franklin St., New York.
Auction Sales of Plants, Etc.
For page see List of Advertisers.

AZALEAS

A. Lenthly & Co., Perkins St. Nurseries, Roslindale, Mass.
For page see List of Advertisers.
W. W. Edgar Co., Waverley, Mass.
For page see List of Advertisers.
August Rolker & Sons, New York, 31 Barclay St., or P. O. Box 752.
For page see List of Advertisers.

BAMBOO CANES

Stumpff & Walter Co., 50 Barclay St., New York.
For page see List of Advertisers.
Yokohama Nursery Co., 31 Barclay Street, New York.
For page see List of Advertisers.

BAY TREES.

Bay Trees and Box Trees, standards and pyramids. All sizes. Price list on application. J. Roehrs Co., Rutherford, N. J.

BEDDING PLANTS

R. Vincent, Jr., & Sons Co., White Marsh, Maryland.
For page see List of Advertisers.
Carlman Bibsam, 31 Wall St., Trenton, N. J.
For page see List of Advertisers.

BOILERS

BOILERS. "Burnham" Boilers made for greenhouse heating. Lord & Burnham, 1133 Broadway, N. Y.

BOXWOOD

Henry M. Robinson & Co., 15 Province St., Boston.
For page see List of Advertisers.
N. F. McCarthy & Co., 84 Hawley St., Boston, Mass.

BUILDING MATERIAL

BUILDING MATERIAL of all description for All Cypress, Semi-Iron, Iron Frame or Truss Houses. Hot Bed Sash and Frames. Lord & Burnham Co., 1133 Broadway, N. Y.

BULBS AND TUBERS

Joseph Breck & Sons, 47-54 N. Market St., Boston.
For page see List of Advertisers.
J. M. Thornburn & Co., 33 Barclay St., New York.
For page see List of Advertisers.
A. T. Boddington, 342 W. 14th St., N. Y.
For page see List of Advertisers.

Rickards Bros., 37 East 19th St., New York.
For page see List of Advertisers.
H. F. Michell Co., Philadelphia.
For page see List of Advertisers.

H. E. Fiske Seed Co., Faneuil Hall Sq., Boston.
For page see List of Advertisers.

James Vlek's Sons, Rochester, N. Y.
Fall Bulbs.
For page see List of Advertisers.

D. Rusconi, 128 W. Sixth St., Cincinnati, O.
Cold Storage.
For page see List of Advertisers.

Aug. Rolker & Sons, 31 Barclay St., New York.

Seasonable Import Plants and Bulbs.
For page see List of Advertisers.
K. Velthuis, Hillegom, Holland,
Represented by Felix Bosch, 260 Clarendon St., Boston.

Bulbs French and Dutch.
For page see List of Advertisers.

Ralph M. Ward & Co., 2 W. Broadway, New York, Agts. for Martial Bremond, Ollioules, France.

French Bulbs.
For page see List of Advertisers.
Stumpff & Walter Co., 50 Barclay St., New York.

Canna Bulbs.
For page see List of Advertisers.

CANNAS

The Conard & Jones Co., West Grove, Pa.
For page see List of Advertisers.

Good Robusta, dark-leaved, at \$1.50 per 100; large clumps Burbank, Mlle. Berat and Clunelair, at \$2.00 per 100; Pennsylvania, at \$2.50 per 100. C. W. Moeckel, 17 Summer St., Fitchburg, Mass.

Cannas: Dormant roots, Chas. Henderson, Coronet, Allemania, America, Austria, Burbank, Grand Ronde, Partenope, Pres. Carnot, Pres. Favre, D. J. Sisley, L. Patry, Robusta, T. S. Ware, \$1.20 per 100. Mixed colors \$1.00. 10 per cent off 1000 lots. Cash with order. All popular varieties. Low contract prices for next season. Largest canna farms in U. S. Vick's Branching Aster seed, white, 50c. oz. Salvia Bonfire, \$2.00 oz. All florists' seeds at fair prices. Binghamton Seed Co., Binghamton, N. Y.

CARNATIONS

F. Dorner & Soos Co., Lafayette, Ind.
For page see List of Advertisers.
S. S. Skidelsky, 1741 N. 18th St., Philadelphia.
For page see List of Advertisers.

Chicago Carnation Co., Joliet, Ill.
For page see List of Advertisers.
H. A. Jahn, New Bedford, Mass.
Carnation Lloyd.
For page see List of Advertisers.

John E. Haines, Bethlehem, Pa.
Carnations Imperial and Pink Imperial.
For page see List of Advertisers.

Chas. H. Totty, Madison, N. J.
For page see List of Advertisers.

CARNATIONS—Continued

A. N. Pierson, Cromwell, Conn.
For page see List of Advertisers.
F. R. Pierson Co., Tarrytown, N. Y.
Winsor and White Enchantress Rooted Cuttings.

Carnation cuttings of all the leading varieties at the same price as any reliable firm. Write for prices before you look elsewhere. Wm. F. Kastling Co., 363 Elliott St., Buffalo, N. Y.

CHRYSANTHEMUMS

Chas. H. Totty, Madison, N. J.
Single Chrysanthemums.
For page see List of Advertisers.

A. N. Pierson, Cromwell, Conn.
For page see List of Advertisers.

Will have 100,000 rooted cuttings of the best 60 commercial varieties ready about March 25. Have your orders booked now. Postal will bring new price list. Satisfaction guaranteed. W. Ehmann, Corfu, N. Y.

Chrysanthemums ready: 2 1-2 inch strong stock of Tonsel, Oct. Frost, Polly Rose, Wanamaker, and all standards, \$3 per 100, \$25 per M. New: 2 1-2, strong, Alice Roosevelt, Hankey, Clay Frick, Winter Cheer, Rosette, B. May, \$5 per 100, \$40 per M. Cash. Send for catalog. Harlowarden Greenhouses, Greenport, N. Y.

CONIFERS

John Waterer & Sons, Ltd., American Nursery, Bagshot, Eng.
For page see List of Advertisers.
New England Nurseries, Bedford, Mass.
For page see List of Advertisers.

CUT FLOWER BOXES.

Edwards Folding Box Co., Philadelphia.
For page see List of Advertisers.
Folding cut flower boxes, the best made. Write for list. Holton & Hunkel Co., Milwaukee, Wis.

DAHLIAS

David Herbert & Son, Atco, N. J.
For page see List of Advertisers.
J. L. Moore, Northboro, Mass.
For page see List of Advertisers.

15,000 Field-grown clumps 2c. and up. List ready. H. W. Koerner, Sta. B, Milwaukee, Wis.

Dahlias: About 2000 Cath. Duer, Kriemhilde, Brunnhilde, Snowclad, etc., \$3 per 100. Cash. Harlowarden Greenhouses, Greenport, N. Y.

Dahlia Roots—Undivided field clump. Lyndhurst, Maid of Kent, William Agnew, White Swan, Kreimhilde, John Walker, Arabella and A. D. Lyon. Write for low prices. Wood & Healey, Hammonton, New Jersey.

Cactus, Decorative, Show, Fancy and Pompon Dahlias. 75 leading varieties to select from. Strong divided clumps, in 10 or 20 varieties, my selection at \$3.00 per 100; \$25.00 per 1000. Single Dahlias, mixed, \$1.00 per 100. Cash with order please. Hermann Thiemann, Monson, Mass.

DECORATIVE PLANTS

A. Lenthly & Co., Perkins St. Nurseries, Roslindale, Mass.
For page see List of Advertisers.

EASTER PLANTS

Wm. W. Edgar Co., Waverley, Mass.
For page see List of Advertisers.
A. Lenthly & Co., Perkins St. Nurseries, Roslindale, Mass.
For page see List of Advertisers.

ENGLISH WALL FLOWERS

Henry A. Dreer, 714 Chestnut St., Philadelphia, Pa.
For page see List of Advertisers.

For List of Advertisers See Page 392

EUONYMUS RADICANS

Euonymus radicans, 1-1 1/2 ft., \$6.00; 2-2 1/2 ft., \$8.00 per 100. Bushy plants. Brae-Burn Nursery, West Newton, Mass.

EVERGREENS

The New England Nurseries, Bedford, Mass.

For page see List of Advertisers.

FERNS

A. Leuthy & Co., Roslindale, Mass. For page see List of Advertisers.

H. H. Barrows & Son, Whitman, Mass. Nephrolepis Whitmaul.

For page see List of Advertisers.

Godfrey Aschmann, 1012 Ontario St., Philadelphia, Pa.

For page see List of Advertisers.

John Scott, Brooklyn, N. Y.

For page see List of Advertisers.

Baur Floral Co., Erie, Pa.

For page see List of Advertisers.

Nephrolepis Exaltata Bostoniensis, fine young plants, \$10.00 per 1000.

N. Elegantisima, young plants \$15.00 per 1000. Send for price list. Soar Bros. Little River, Fla.

FERTILIZERS

Pulverized Manure Co., 31 Union Stock Yards, Chicago, Ill.

Wizard Brand Cattle Manure.

For page see List of Advertisers.

Thos. J. Grey & Co.,

32 and 33 South Market St., Boston.

High-Grade Scotch Soot.

For page see List of Advertisers.

FLORAL PHOTOGRAPHS

Floral Photographs. Foley's 226-228 1-2 Bowery, New York.

FLORISTS' LETTERS.

Boston Florist Letter Co., 66 Pearl St., Boston, Mass.

For page see List of Advertisers.

Koral Mfg. Co., 26 Hawley St., Boston. For page see List of Advertisers.

FLORISTS SUPPLIES

H. M. Robinson & Co., 15 Province St. and 9 Chapman Pl., Boston, Mass.

For page see List of Advertisers.

The Keivso Co., 113 W. 28th St., N. Y. Decorative Evergreens.

For page see List of Advertisers.

Keed & Keller, 122 W. 25th St., New York. For page see List of Advertisers.

J. B. Murdoch & Co., 714 Penn Ave., Pittsburg, Pa.

For page see List of Advertisers.

H. Bayersdorfer & Co., 1129 Arch St., Philadelphia.

For page see List of Advertisers.

Alex. Mann, Jr., Co., 1125 Polk St., San Francisco, Calif.

For page see List of Advertisers.

FLOWERS BY TELEGRAPH

Park Floral Co., Denver, Colo. For page see List of Advertisers.

J. N. Champion & Co., 1026 Chapel St., New Haven, Conn.

For page see List of Advertisers.

George H. Cooke, Washington, D. C. For page see List of Advertisers.

Gude Bros. Co., 1214 F St., Washington, D. C.

For page see List of Advertisers.

Atlanta Floral Co., Atlanta, Ga.

For page see List of Advertisers.

M. C. & J. E. Hauswirth, 232 Michigan Ave., Chicago.

For page see List of Advertisers.

William J. Smyth, Michigan Ave. and 31st St., Chicago.

For page see List of Advertisers.

Jacob Schurz, 644 4th Ave., Louisville, Ky.

For page see List of Advertisers.

Thos. F. Galvin, 124 Tremont St., Boston. For page see List of Advertisers.

Julius A. Zinn, 2 Beacon St., Boston.

For page see List of Advertisers.

Houghton & Clark, 396 Boylston St., Boston.

For page see List of Advertisers.

Sidney Hoffman, 59-61 Massachusetts Ave., Boston.

For page see List of Advertisers.

For page see List of Advertisers.

FLOWERS BY TELEGRAPH -

Continued

Edward MacMullin, 194 Boylston St., Boston.

For page see List of Advertisers.

J. Brettmeyer's Sons, Miami and Gratto Aves., Detroit, Mich.

For page see List of Advertisers.

Samuel Murray, 1017 Broadway, Kansas City, Mo.

For page see List of Advertisers.

Wm. L. Rock Flower Co., 1116 Walnut St., Kansas City, Mo.

For page see List of Advertisers.

Fred C. Weber, 4326-28 Olive St., St. Louis, Mo.

For page see List of Advertisers.

H. G. Eyres, 11 N. Pearl St., Albany, N. Y.

For page see List of Advertisers.

David Clarke's Sons, 2139-2141 Broadway, New York.

For page see List of Advertisers.

W. H. Donohoe, 17 E. 28th St., New York.

For page see List of Advertisers.

Alex. McConnell, New York.

For page see List of Advertisers.

M. A. Bowe, 1294 Broadway, New York.

For page see List of Advertisers.

Robert G. Wilson, Fulton St. & Greene Av., Brooklyn, N. Y.

For page see List of Advertisers.

Thomas Young, Jr., 500 Fifth Ave., N. Y.

For page see List of Advertisers.

Young & Nugent, 42 W. 28th St., N. Y.

For page see List of Advertisers.

FLOWER POTS

W. H. Leach, 280 and 8th Sts., Washington, D. C.

For page see List of Advertisers.

A. H. News & Co., Cambridge, Mass. For page see List of Advertisers.

Hilfinger Bros., Ft. Edward, N. Y.

For page see List of Advertisers.

Paper pots for all early vegetables. Two inch pots \$1.00 a thousand; three inch \$1.25; four inch \$1.60. P. B. Crosby, Catonsville, Md.

GALAX

Michigan Cut Flower Co., 38 and 40 Broadway, Detroit, Mich.

For page see List of Advertisers.

N. F. McCarthy & Co., 84 Hawley St., Boston.

Green and Bronze Galax.

GERANIUMS

R. Vincent Jr. & Sons Co., White Marsh, Md.

New and Standard Varieties.

For page see List of Advertisers.

Geraniums, 2 in., double red, \$2.00 per 100. J. H. Dann & Son, Westfield, N. Y.

500 Nutt Geranium Cuttings, \$1.50 per 100, or the lot for \$6.50. C. W. Moeckel, 17 Summer St., Fitchburg, Mass.

Geranium Mme. Satorol, strong 2 in., ready for 3 in., \$2.00 per 100. Cash E.H.B. Brothers & Company, Keene, N. H.

The S. A. Nutt geraniums advertised in your Buyer's Directory went fine. Did not have enough to supply the demand. C. W. Moeckel, 17 Summer St., Fitchburg, Mass.

GLADIOLI

Arthur Cowee, Meadowvale Farm, Berlin, New York.

For page see List of Advertisers.

J. L. Moore, Northboro, Mass.

For page see List of Advertisers.

I. & J. L. Leonard, Iona, N. J.

Gladiolus Bulbs.

For page see List of Advertisers.

Gladioli. Write for leaflet. B. Hammond Tracy, Cedar Acres, Wenham, Mass.

Gladioli. Named varieties and mixtures. Send for list. E. E. Stewart, Rives Junction, Mich.

GLASS

Boston Plate & Window Glass Co., Boston. For page see List of Advertisers.

Standard Plate Glass Co., 26-30 Sudbury St., Boston.

For page see List of Advertisers.

S. Jacobs & Sons, 1305-79 Flushing Ave., Brooklyn, N. Y.

For page see List of Advertisers.

GLASS - Continued

Metropolitan Material Co., 1398-1408 Metropolitan Ave., Brooklyn, N. Y.

Foley Mfg. Co., between Western Ave. and 26th St., Chicago, Ill.

Greenhouse glass, lowest prices. Johnston Glass Co., Hartford City, Ind.

GLASS, High Grade, Double Thick Greenhouse Glass. Lord & Burnham, 1133 Broadway, N. Y.

GLAZING POINT

H. A. Dreer, Philadelphia, Pa. For page see List of Advertisers.

GLAZING POINTS, Lord & Burnham Special Glazing Nails (Points). Lord & Burnham, 1133 Broadway, N. Y.

GREENHOUSE BUILDING MATERIAL.

Lord & Burnham Co., 1133 Broadway, New York.

For page see List of Advertisers.

Plerson U-Bar Co., 1 Madison Sq., N. Y. For page see List of Advertisers.

A. T. Stearns Lumber Co., Neponset, Boston.

For page see List of Advertisers.

King Construction Co. N. Tonawanda, New York.

For page see List of Advertisers.

J. C. Moninger Co., 117 East Blackhawk St., Chicago, Ill.

For page see List of Advertisers.

Foley Mfg. Co., between Western Ave. and 26th St., Chicago, Ill.

For page see List of Advertisers.

I. Cassidy, Summer Ave. and Erie R. R., Newark, N. J.

For page see List of Advertisers.

W. H. Lutton, Jersey City, N. J.

For page see List of Advertisers.

Geo. R. Doane, 18 Midway St., Boston. Iron Pipe.

For page see List of Advertisers.

S. Jacobs & Sons, 1305-79 Flushing Ave., Brooklyn, N. Y.

For page see List of Advertisers.

Metropolitan Material Co., 1398-1408 Metropolitan Ave., Brooklyn, N. Y.

GREENHOUSE CONSTRUCTION

GREENHOUSE CONSTRUCTION, Semi Iron Greenhouse, New Truss Houses and Iron Frame Houses. Lord & Burnham, 1133 Broadway, N. Y.

J. A. Payne, 260-274 Culver Ave., Jersey City, N. J.

For page see List of Advertisers.

I. Cassidy, Summer Ave. and Erie R. R., Newark, N. J.

For page see List of Advertisers.

Foley Mfg. Co., between Western Ave. and 26th St., Chicago, Ill.

For page see List of Advertisers.

W. H. Lutton, Jersey City, N. J.

For page see List of Advertisers.

GREENHOUSE HOSE

Microalzed Rubber Co., 18 Cliff St., N. Y. For page see List of Advertisers.

GUTTERS

GUTTERS, Cast Iron Gutters, L. & B. Improved V Shaped Gutter with drip gutter attachment. Lord & Burnham, 1133 Broadway, N. Y.

HAIL INSURANCE

Florists' Hall Asso. of America. J. G. Esler, Saddle River, N. J.

For page see List of Advertisers.

HARDY FERNS AND SUPPLIES

H. M. Robinson & Co., 15 Province St. and 9 Chapman Pl., Boston, Mass.

For page see List of Advertisers.

The Kervan Co., 113 W. 28th St., N. Y. For page see List of Advertisers.

Michigan Cut Flower Exchange, 38 and 40 Broadway, Detroit, Mich.

Fancy Ferns.

For page see List of Advertisers.

H. J. Smith, Hinsdale, Mass.

For page see List of Advertisers.

N. F. McCarthy & Co., 84 Hawley St., Boston.

Hardy Ferns.

In writing to Advertisers kindly mention Horticulture

HART'S HANDY HANDLE

Geo. B. Hart, 21 Stone St., Rochester, N. Y.
For page see List of Advertisers.

HEATING APPARATUS

Lord & Burnham Co.,
1133 Broadway, New York.
For page see List of Advertisers.
Pierson U-Bar Co., 1 Madison Sq., N. Y.
For page see List of Advertisers.
John A. Payne, 260-274 Chilver Ave., Jersey
City, N. J.
For page see List of Advertisers.

HELP FURNISHED

Thos. H. Bambrick, 34 S. 7th St., Phila.
For page see List of Advertisers.

HERBACEOUS PERENNIALS

Red Oak Nurseries, Fiskeville, R. I.
For page see List of Advertisers.

HOSE

Frank L. Moore, Chatham, N. J.
Summyside Hose.
For page see List of Advertisers.
H. A. Dreer, 714 Chestnut St., Phila., Pa.
Riverton Hose.

HOT-BED MATS

G. H. Frost, W. Newton, Mass.
For page see List of Advertisers.

HOT-BED SASH

The A. T. Stearns Lumber Co., Neposet,
Mass.
For page see List of Advertisers.
Pierson U-Bar Co., 1 Madison Sq., N. Y.
For page see List of Advertisers.

Lord & Burnham Co., 1133 Broadway, N. Y.
For page see List of Advertisers.
Foley Mfg. Co., between Western Ave. and
26th St., Chicago, Ill.

HYDEANGEAS.

HYDRANGEAS PANICULATA.
Grandiflora, 18 in. to 24 in., \$5.00 per 100.
Grandiflora, 2 ft. to 3 ft., \$7.00 per 100.
Grandiflora, 3 ft., \$8.00 per 100.
J. H. Damm & Son, Westfield, N. Y.

INSECTICIDES.

Nicotifide kills all greenhouse pests
P. R. Palethrope Co.,
Eleventh St., Owensboro, Ky.
For page see List of Advertisers.
Wm. Elliott & Sons, 201 Fulton St.,
New York.
Target Brand Insecticides.
For page see List of Advertisers.

IRISES

Japanese Iris, 25 choicest varieties, large,
well rooted divisions, \$10 per 100. Yucca
filamentosa, \$15 per 100. T. H. Chivers,
Amesbury, Mass.

JAPANA CUT FLOWER HOLDER

M. V. Garusey, 130 Walola Ave.,
La Grange, Ill. Dept. M.
For page see List of Advertisers.

KENTIAS

A. Lenthy & Co., Roslindale, Mass.
For page see List of Advertisers.
Godfrey Aschmann, 1012 W. Ontario St.,
Philadelphia.
For page see List of Advertisers.

LEADING RETAIL FLORISTS

Park Floral Co., Denver, Colo.
For page see List of Advertisers.
George H. Cooke, Washington, D. C.
For page see List of Advertisers.
Gude Bros. Co., 1214 F St.,
Washington, D. C.
For page see List of Advertisers
Atlanta Floral Co., Atlanta, Ga.
For page see List of Advertisers.
M. C. & J. E. Hauswirth, 232 Michigan Ave.,
Chicago.
For page see List of Advertisers.
William J. Smyth, Michigan Ave. and 31st
St., Chicago.
For page see List of Advertisers
Jacob Schulz, 644 4th Ave., Louisville, Ky.
For page see List of Advertisers
Thos. F. Galvin, 124 Tremont St., Boston.
For page see List of Advertisers
Julius A. Zinn, 2 Beacon St., Boston.
For page see List of Advertisers.

LEADING RETAIL FLORISTS —**Continued**

Houghton & Clark, 396 Boylston St.,
Boston.
For page see List of Advertisers.
Sidney Hoffmann, 59-61 Massachusetts Ave.,
Boston.
For page see List of Advertisers.
Edward MacMullikin, 194 Boylston St.,
Boston.
For page see List of Advertisers.
J. Breitmeyer's Sons, Detroit, Mich.
For page see List of Advertisers.
Samuel Murray, 1017 Broadway,
Kansas City, Mo.
For page see List of Advertisers.
Wm. L. Rock Flower Co., 1116 Walnut
St., Kansas City, Mo.
For page see List of Advertisers.
Fred C. Weber, 4326 Olive St., St. Louis,
Mo.
For page see List of Advertisers.
J. N. Champion & Co., 1026 Chapel St.,
New Haven, Conn.
For page see List of Advertisers.
H. G. Eyree, 11 N. Pearl St., Albany, N. Y.
For page see List of Advertisers.
David Clarke's Sons, 2139-2141 Broadway,
New York.
For page see List of Advertisers.
W. I. Donohoe, 17 E. 28th St., New York.
For page see List of Advertisers.
Alex. McConnell, New York.
For page see List of Advertisers.
M. A. Bowe, 1294 Broadway, New York.
For page see List of Advertisers.
Robert G. Wilson, Fulton St. and Greene
Ave., Brooklyn, N. Y.
For page see List of Advertisers.
Thomas Young, Jr., 500 Fifth Ave., N. Y.
For page see List of Advertisers.
Young & Nugent, 42 W. 28th St., N. Y.
For page see List of Advertisers.

NEW AND RARE PLANTS

Rose Hill Nurseries, New Rochelle, N. Y.
For page see List of Advertisers.

NICO-FUME

Kentucky Tobacco Product Co.,
Lonsville, Ky.

NURSERY STOCK

John Waterer & Sons, Ltd.,
American Nursery, Bagshot, England.
For page see List of Advertisers.
New England Nurseries, Bedford, Mass.
Shrubs, Roses and Herbaceous Perennials.
Specimen Pyramidal Box.
For page see List of Advertisers.
Bay State Nurseries, N. Abington, Mass.
Herbaceous Perennials, Hardy Ornamental
Trees.
For page see List of Advertisers.

Cleary's Horticultural Co., 62 Vesey St.,
New York.

For page see List of Advertisers.

P. Ouwkerk, 216 Jane St., Weehawken
Helghts, N. J.
Holland Nursery Stock for Forcing.
For page see List of Advertisers.

American Nursery Co., 150 Broadway, New
York, N. Y.
For page see List of Advertisers.

I. & J. L. Leonard, Ina, N. J.
California Privet, American Chestnuts.
For page see List of Advertisers.

D. J. Twomey, Dept. H., Geneva, N. Y.
Trees and Plants.
For page see List of Advertisers.

Carlman Ribsam, 31 Wall St.,
Trenton, N. J.
California Privet, Trees, Shrubs, Etc.
For page see List of Advertisers.

The Morris Nursery Co.,
Sales Office, 1 Madison Ave., New York.
Ornamental Trees, Evergreens, Hedge
Plants.
For page see List of Advertisers.

Peter's Nursery Co., Knoxville, Tenn.
Live Fences; Amoor and California Privet.
For page see List of Advertisers.

Pierce Nurseries, Beverly Farms, Mass.
Tree Seedlings and Rooted Cuttings.

ORCHID PLANTS

Lager & Hurrell, Summit, N. J.
For page see List of Advertisers.
Sander, St. Albans, England.
Importers, Exporters, Growers, Hybridists
For page see List of Advertisers.
Julius Roehrs Co., Rutherford, N. J.
For page see List of Advertisers.
Carrillo & Baldwin, Secaucus, N. J.
For page see List of Advertisers.
Jos. A. Mabda, 191 Valley Road, W.
Orange, N. J.
For page see List of Advertisers.
Ordonez Bros., Madison, N. J., Box 105.
For page see List of Advertisers.

PALMS

A. Lenthy & Co., Perkins St. Nurseries,
Roslindale, Mass.
For page see List of Advertisers.
Robert Craig Co., Market and 49th Sts.,
Philadelphia, Pa.
For page see List of Advertisers.
Kentia, Phoenix, etc., all sizes. Write
for new price list. Julius Roehrs Co.,
Rutherford, N. J.

PAINT AND PUTTY

PAINT AND PUTTY: Ideal Greenhouse
lead; Spectal Greenhouse Putty. Lord &
Burnham, 1133 Broadway, N. Y.

PANSY PLANTS.

Choice pansy plants, 50c per 100; \$4.00
per 1000. Cash. Ang. Zirngelbel, Need-
ham, Mass.

PATENTS

Siggers & Siggers, Washington, D. C.
For page see List of Advertisers.

PEAT

Orchid peat, Rotted peat, Azalea peat,
Leaf-Mould, Live Sphagnum moss, Baled
Sphagnum moss, Green Clump moss, etc.
Johann's list on application. C. W. Brown-
ell & Co., Walden, N. Y.

PELARGONIUMS

R. Vincent, Jr. & Sons Co., White Marsh,
Maryland.
For page see List of Advertisers.

PEONIES

Wholesale Peony list for fall 1908 is now
ready. J. F. Rosenfield, West Point, Neb.

One of the finest collections in America.
Send 25 cts. in stamps for new edition of
Peony Manual. C. S. Harrison's Select
Nursery, York, Neb.

PHLOXES

Send 25 cts. in stamps for Phlox Manual.
Fine mixed phloxes \$1.50 per 100. C. S.
Harrison's Select Nursery, York, Neb.

PIPE AND FITTINGS

Foley Mfg. Co., between Western Ave. and
26th St., Chicago, Ill.

Eagle Metal & Supply Co., Johnson and
Union Aves., Brooklyn, N. Y.
Second-Hand Pipe and Boiler Tubes.
For page see List of Advertisers.

PIPE AND FITTINGS. Cast Iron and
Wrought Pipe, Valves, Elbows, Pipe Hooks,
Automatic Air Headers, etc. Lord &
Burnham, 1133 Broadway, N. Y.

PLANT BED CLOTH

Mineralized Rubber Co., 18 Cliff St., N. Y.
For page see List of Advertisers.

PLANT STAKES AND TRELLISES

Seale's Patent, for roses, chrysanthem-
ums, gladioli, tuberose, dahlias, toma-
toes, egg plants, etc. H. D. Seale & Sons,
Manufact., Elbart, Ind.

POT HANGERS

Pot hangers, Kramer's \$1 doz. by exp.
\$1.25 by mail. I. N. Kramer & Son, Cedar
Rapids, Ia.

RAFFIA

Raffia (colored), 20 beautiful shades
Samples free. R. H. Comey Co., Camden,
N. J.; 810 Washburn Ave., Chicago, Ill.

For List of Advertisers See Page 392

RHODODENDRONS

John Waterer & Sons, Ltd.,
American Nursery, Bagshot, England.
For page see List of Advertisers.
P. Onwekerk, Hoboken, N. J.
For page see List of Advertisers.

ROSES

Jullna Roehrs Co., Rutherford, N. J.
Rambler Rose, Newport Fairy.
For page see List of Advertisers.
New England Nurseries, Inc., Bedford,
Mass.
For page see List of Advertisers.
Bay State Nurseries, N. Abington, Mass.
For page see List of Advertisers.
Ellwanger & Barry, Rochester, N. Y.
Hardy Roses.
For page see List of Advertisers.
Robert Craig Co., Market and 49th Sts.,
Philadelphia, Pa.
For page see List of Advertisers.
Dingee-Conard Co., West Grove, Pa.
New Climbing Rose, Tansendschon.
For page see List of Advertisers.

The Morris Nursery Co.,
Sales Office, 1 Madison Ave., New York.
Ornamental Trees, Evergreens, Hedge
Plants.
For page see List of Advertisers.
John Cook, 318 Charles St., N. Baltimore,
Maryland.
Rose My Maryland.

400 varieties; own roots; summer grown.
Leedle Company, Springfield, Ohio.

Crimson Ramblers, 2 year, on own roots,
extra strong, at 7 cents. Gilbert Costleh,
Rochester, N. Y.

Low-budded roses, No. 1, \$95.00; No.
11-2, \$65.00 1000. H. T. Jones, Elizabeth,
N. J.

SEEDS

T. J. Grey Co., 32 So. Market St.,
Boston, Mass.
For page see List of Advertisers.
Joseph Breck & Sons,
51 and 52 N. Market St., Boston, Mass.
For page see List of Advertisers.
W. Atlee Burpee & Co., Philadelphia.
For page see List of Advertisers.
J. M. Thorburn & Co., 33 Barclay St., N. Y.
For page see List of Advertisers.
A. T. Boddington, 342 W. 14th St., N. Y.
For page see List of Advertisers.

H. F. Mitchell Co., 1017 Market St., Phila.
For page see List of Advertisers.
James Vick's Sons, Rochester, N. Y.
Vick's Superb Pansy Seed.
For page see List of Advertisers.
Hjalmar Hartmann & Co.,
12 Storingasen, Copenhagen, Denmark.
Cauliflower and Cabbage Seed.
For page see List of Advertisers.

Rickards Bros., 37 E. 19th St., New York.
For page see List of Advertisers.

R. & J. Farquhar & Co., 6-7 So. Market
St., Boston.
Giant Cyclamen Seed.
For page see List of Advertisers.

C. C. Morse & Co., 48-56 Jackson St.,
San Francisco, Cal.
For page see List of Advertisers.

H. E. Fiske Seed Co., Faneuil Hall Sq.,
Boston.
Aster Seed.
For page see List of Advertisers.

Branlan Seed Growers Co., San Jose, Cal.
For page see List of Advertisers.

O. V. Zangen, Hoboken, N. J.
For page see List of Advertisers.

Stump & Walter Co., 50 Barclay St.,
New York.
For page see List of Advertisers.

Wieber & Don, 114 Chambers St.,
New York.
For page see List of Advertisers.

Altimo Culture Co., Canfield, O.
Aster Seed.
For page see List of Advertisers.

R. Wilohlt, Nakskov, Denmark.
Snowball Cauliflower Seed.

Watkins & Simpson, 12 Tavistock St.,
London, Eng.
Sweet Peas.

SEEDS - Continued

Asparagus 11 Nanus, \$2.50 per 1000.
Plant early. Asparagus Plants 14 to 18
inches high, \$6 per 100. Peter Mack, Box
172, Orlando, Fla.

500 bu. choice Canada cluster Oats
(weigh 40 lbs.); 250 bu. choice two row Bar-
ley; field and garden seeds of all kinds.
The Bell Seed Co., Manlius, N. Y.

SEEDS SEEDS SEEDS
Buckbee's Famous "Full of Life" Pedig-
reed Strains of the newest and best varie-
ties vegetable and flower seeds, etc. If
you have failed to receive a copy of our
Spring Trade List write for it today. H.
W. Buckbee, Rockford, Illinois. Rockford
Seed Farms. Forest City Greenhouses.

SMILAX

E. A. Beaven, Evergreen, Ala.
Southern Wild Smilax; Log Mosses.
For page see List of Advertisers.

SPHAGNUM MOSS

Live Sphagnum moss, orchid pent and
orchid baskets always on hand. Lager &
Hurrell, Summit, N. J.

STRAWBERRY PLANTS

M. Crawford Co., Cuyahoga Falls, O.
New Strawberry, The Highland.
For page see List of Advertisers.

STEAM TRAP

E. Hippard, Youngstown, O.

VENTILATING APPARATUS

Pierson U-Bar Co., 1 Madison Sq., N. Y.
For page see List of Advertisers.

Foley Mfg. Co., between Western Ave. and
26th St., Chicago, Ill.
For page see List of Advertisers.

John A. Payne, 260-274 Culver Ave., Jersey
City, N. J.
For page see List of Advertisers.

VENTILATING MACHINERY, New
Model encased, self-oiling gear; Standard
Model Open Gear. Lord & Burnham, 1133
Broadway, N. Y.

VIOLETS

William Slim, Cliftondale, Mass.
Violet Boston.
For page see List of Advertisers.

Violet cuttings, "Maria Louisa" Rhine-
beck stock, rooted runners, May delivery
\$20.00 M. Immediate delivery, between
now and March 15th, \$10.00 M. Wm. F.
Kasting Co., 383 Elliott St., Buffalo, N. Y.

WIREWORK

Reed & Keller, 122 W. 25th St., N. Y.
For page see List of Advertisers.

Wirework. Write for our catalogue.
Holton & Hunkel Co., Milwaukee, Wis.

William E. Hellscher's Wire Works, 28-40
Broadway, Detroit, Mich.

The "Just Right" kind. Send for price
list. Frank W. Ball, 31 East Third Street,
Cincinnati, O.

WOOD MOSS

D. Rusconi, 128 W. 6th St., Cincinnati, O.
For page see List of Advertisers.

WHOLESALE FLORISTS

Boston

N. F. McCarthy & Co., 84 Hawley St.,
Boston.
For page see List of Advertisers.

H. M. Robinson & Co., 15 Province St.
and 9 Chapman Pl., Boston.
For page see List of Advertisers.

Welch Bros., 226 Devonshire St., Boston.
For page see List of Advertisers.

Buffalo

Wm. F. Kasting Co., 383-87 Elliott St.,
Buffalo, N. Y.
For page see List of Advertisers.

Chicago

Chas. W. McKellar, 51 Wabash Ave.,
Chicago.
For page see List of Advertisers.

Peter Relaborg, 51 Wabash Ave., Chicago.
For page see List of Advertisers.

E. F. Winterson Co., 35-49 Wabash Ave.,
Chicago.
For page see List of Advertisers.

WHOLESALE FLORISTS-

**Continued
Detroit**

Michigan Cut Flower Exchange, 38 and 40
Broadway, Detroit, Mich.
For page see List of Advertisers.

Minneapolis

Rice Bros., 115 N. 6th St., Minneapolis,
Minn.
For page see List of Advertisers.

New York

J. K. Allen, 106 W. 28th St., New York.
For page see List of Advertisers.

J. S. Fenrich, 110 W. 28th St., New York.
For page see List of Advertisers.

Ford Bros., 48 W. 28th St., New York.
For page see List of Advertisers.

H. E. Froment, 57 W. 28th St., New York.
For page see List of Advertisers.

Alex. J. Guttman, 43 W. 28th St., New
York.
For page see List of Advertisers.

E. C. Horan, 55 W. 28th St., New York
For page see List of Advertisers.

A. H. Langjahr, 55 W. 28th St., New York.
For page see List of Advertisers.

James McLanau, 42 W. 28th St., New York
For page see List of Advertisers.

John I. Raynor, 49 W. 28th St., New York.
For page see List of Advertisers.

W. F. Sheridan, 39 W. 28th St., New York.
For page see List of Advertisers.

Traendly & Schebeck, 44 W. 28th St., New
York.
For page see List of Advertisers.

John Young, 51 W. 28th St., New York.
For page see List of Advertisers.

Moore, Hentz & Nash, 55 and 57 W. 26th
St., New York.
For page see List of Advertisers.

Frank S. Hicks & Co., 52 W. 28th St.,
New York.
For page see List of Advertisers.

Frank Millang, 57 W. 26th St., New York.
For page see List of Advertisers.

Wm. H. Kuebler, 28 Willoughby St.,
Brooklyn, N. Y.
For page see List of Advertisers.

Philip F. Kessler, 55 and 57 W. 26th St.,
New York.
For page see List of Advertisers.

A. Moltz, 55-57 W. 26th St., New York.
For page see List of Advertisers.

B. S. Sloan, Jr., 55 W. 26th St., New York.
For page see List of Advertisers.

Millang Bros., 41 W. 28th St., New York.
For page see List of Advertisers.

Philadelphia

W. E. McKissock, 1619-1621 Ranstead St.,
Philadelphia, Pa.
For page see List of Advertisers.

Leo Nlessen Co., 1209 Arch St., Philadel-
phia, Pa.
For page see List of Advertisers.

The S. S. Pennock-Meehan Co., 1605-18
Ludlow St., Philadelphia, Pa.
For page see List of Advertisers.

Edward Reid, 1526 Ranstead St., Phila-
delphia, Pa.
For page see List of Advertisers.

Pittsburg

J. B. Murdoch & Co., 714 Penn Ave., Pitts-
burgh, Pa.
For page see List of Advertisers.

San Francisco

Alex. Mann, Jr., Co., 1125 Polk St., San
Francisco, Cal.
For page see List of Advertisers.

St. Louis

H. G. Berning, 1402 Pine St., St. Louis, Mo.
For page see List of Advertisers.

WHOLESALE PLANTSMAN

Samuel A. Woodrow, 53 W. 30th St.,
New York.
For page see List of Advertisers.

In writing to Advertisers kindly mention Horticulture

List of Advertisers

Table listing advertisers and their page numbers, including Allen J. K., American Nursery Co., Aschmann Godfrey, Atlanta Floral Co., Barrick Thos., Barrows H. H. & Son, Baur Floral Co., Bayersdorfer H. & Co., Bay State Nurseries, Beaven E. A., Berning H. G., Boddington A. T., Boston Florist Letter Co., Boston Plate and Window Glass Co., Bosch, Felix, Bowe, M., Braslan Seed Growers Co., Breck Joseph & Sons, Breitmeyer's J. Sons, Bremond Martial, Bridgeman's Seed Warehouse, Burpee W. A. & Co., Carrillo & Baldwin, Cassidy I., Champion J. N. & Co., Chicago Carnation Co., Clarke's David, Sons, Cleary's Horticultural Co., Conard & Jones Co., Cook John, Cooke G. H., Cowee A., Craig, Robt. Co., Crawford M. & Co., Dinee & Conard Co., Duane Geo. B. & Son, Donohoe W. H., Dorner F. Sons & Co., Dreer H. A., Dysart R. J., Eagle Metal & Supply Co., Edgar, W. W. Co., Edwards Folding Box Co., E. Hott Wm. & Sons, Ellwanger & Barry, Elmsford Nurseries, Esler J. G., E. nest W. H., Eyles, Eyre, Farquhar R. & J., Fenrich J. S., Fiske, H. E. Seed Co., Foley Mfg. Co., Ford Bros., Froment H. E., Frost G. H., Fruit Auction Co., Galvia Thos. F., Garosey M. V., Grey T. J. Co., Gude Bros. Co., Guttman Alex. J., Haerens A., Hall Asso., Haioes, J. E., Hammond Paint & Slug Shot Works, Hart, Geo. B., Hartmann Hjalmar & Co., Hauswirth M. C. & J. E., Herbert David & Son, Hews A. H. & Co., Hicks Frank S. & Co., Hiffner Bros., Hoffman, Horan E. C., Houghton & Clark, Jahn, H. A., Jacobs S. & Sons, Kastung W. P., Kelsey Harlan P., Kepner J. A., Kervan Co., Kessler, P. F., Kibbe Chas. A., King Cons. Co., Koral Mfg. Co., Kramer Bros Fdy Co., Kuebler Wm. H., Lager & Hurrell, Langjahr, Alfred H., Leonard I. & J., Leuthy A. & Co., Lewis A. J. Mfg Co., Lord & Burnham Co., Lunt W. H.

New Offers in This Issue.

AMERICAN HARDY RHODODENDRONS.

Harlan P. Kelsey, Salem, Mass. For page see List of Advertisers.

ASTER LADY ROOSEVELT.

Chas. A. Kibbe, Elmhurst, Ill. For page see List of Advertisers.

BAY TREES.

N. F. McCarthy & Co., 84 Hawley St., Boston. For page see List of Advertisers.

DAHLIAS, RUTH FORBES AND NEWPORT.

Wm. F. Turner & Co., New Bedford, Mass. For page see List of Advertisers.

GLASS.

Parshelsky Bros., 59 Montrose Ave., Brooklyn, N. Y. For page see List of Advertisers.

GLASS.

Boston Plate & Window Glass Co., Boston. For page see List of Advertisers.

GRAFTED STOCK BRIDE, BRIDESMAID, KILLARNEY.

Montrose Greenhouses, Montrose, Mass. For page see List of Advertisers.

GRAPE DUST.

Hammond's Paint & Slug Shot Works, Fishkill on Hudson, N. Y. For page see List of Advertisers.

HARDY ROSES FOR THE GARDEN.

F. R. Pierson Co., Tarrytown on Hudson, N. Y. For page see List of Advertisers.

LILIES, RAMBLERS, ETC., FOR EASTER.

Welch Bros., 226 Devonshire St., Boston. For page see List of Advertisers.

LIVE CANNAS STARTED FROM SAND.

J. B. Shurtleff & Son, Cushman Ave., Revere, Mass. For page see List of Advertisers.

MISSION PLANT BOX.

Wagner Park Conservatories, Sidney, O. For page see List of Advertisers.

PRIMULAS, CHINESE, OBCONICA, STELLATA.

R & J. Farquhar & Co., 6 & 7 S. Market St., Boston. For page see List of Advertisers.

PRIZE ASTER GROWING CONTEST.

Altimo Culture Co., Canfield, O. For page see List of Advertisers.

RAMBLER ROSE NEWPORT FAIRY.

J. Roehrs Co., Rutherford, N. J. For page see List of Advertisers.

ROSES THAT BLOOM FROM JUNE TO NOVEMBER.

M. H. Walsh, Woods Hole, Mass. For page see List of Advertisers.

SEEDS FOR FLORISTS AND MARKET GARDENERS.

W. Atlee Burpee & Co., Philadelphia, Pa. For page see List of Advertisers.

SMILAX.

Vern L. Schluraft, Erie, Pa. For page see List of Advertisers.

SQUABS.

Jno. A. Kepner, Harrisburg, Pa., Box 3. For page see List of Advertisers.

TOBACCO SOAP.

Henry A. Droer, 714 Chestnut St., Philadelphia, Pa. For page see List of Advertisers.

WEEKLY BOARD FILE.

A. F. Lewis Mfg. Co., E. Boston, Mass. For page see List of Advertisers.

HELP WANTED

WANTED—SALESMAN

To Handle Good Side Line On Commission

One who calls on Florists, Seed Houses, Nurseries, Cemetery Superintendents, Monument Dealers, etc.

The Kramer Bros. Foundry Co. DAYTON, OHIO

SITUATIONS WANTED

GOOD MEN

When you need good men, skilled or unskilled, Write:

THOS. H. BAMBRICK

34 South 7th Street Philadelphia

Help of all kinds, including that for Florists, Nurserymen, Seedsmen and the Horticultural trade generally.

SITUATION WANTED—Young man would like a situation as assistant or general greenhouse man on private or commercial place. F. J. Tanev, 132 Guernsey St., Brooklyn, N. Y.

SITUATION WANTED in general greenhouse work; single, age 35, five years' experience, commercial. Address W. W., care HORTICULTURE.

FOR SALE

HOT-BED MATS

STRAW, 6x6, little used 75c to \$1.00 G. H. FROST, West Newton, Mass.

FOR SALE OR TO LET—15 acres of land, nearly all under cultivation; 20,000 sq. ft. glass, house well stocked with carnations, chrysanthemums, etc.; 8-room dwelling house, steam heated; large barn; in a city of 14,000 population, 10 miles from Boston; excellent transportation facilities. Good retail trade now established. Terms will be made satisfactory. Possession given April 1, or sooner if desired. Address A. G., care HORTICULTURE.

FOR SALE—Five acres of good land, three greenhouses of 6000 sq. feet glass, nearly new, 100 holed sash, 8 room dwelling, in good town, at a bargain. Address John A. Miller, Gardener, Creston, Ia.

FOR SALE—A large consignment of 16x 24 double thick American glass, A and B quality. For further information write Parshelsky Brothers, 59 Montrose Avenue, Brooklyn, N. Y.

MISCELLANEOUS WANTS

WANTED,

To buy, to lease with the right to buy, or to lease, several Greenhouses with ground where retailing and landscaping is possible.

Address L. L., care HORTICULTURE.

WANTED TO LEASE with privilege of buying, in good retail district, small area of glass with ten acres rich land, suitable for market gardening or cut flowers. No fancy price paid for stock. Immediate possession. State full particulars, city water, population, rent, size of house, etc. Address: Retailer, care HORTICULTURE.

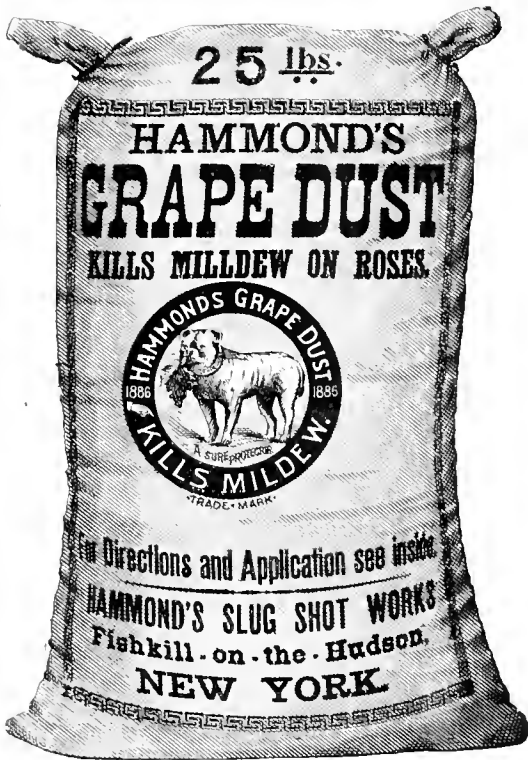

This narrative is the experience of many men and it is true.

Hammond's Grape Dust

For Mildew on Roses, Carnations, Etc., in use since 1884

Clifton, N. J., Oct. 11, 1907.

Dear Mr. Hammond:

In reply to your inquiry regarding my experience with Grape Dust, would say that I am glad to be able to say a good word for the article in question, because I have found it so generally satisfactory when used for mildew on roses.

I do not know anything about its constituents, nor do I care so long as it does the work, and is as economical as anything else on the market.

During the summer when the steam pipes cannot be brought into use to check mildew, and dusting over the foliage has to be resorted to, we prefer to use Grape Dust rather than sulphur, because it is so much lighter and finer in texture; a given number of pounds will cover more than twice the number of plants, will cover them more thoroughly, and Grape Dust can be put on with a bellows in about one-fourth the time that would be required for sulphur.

The fact that I have used it continuously for ten or twelve years should prove to you that I consider it the best article on the market for the purpose for which it is used.

With best wishes I am, Yours very truly, ROBERT SIMPSON.

Put up in 5 and 10 lb. packages at 7 cents per lb.; also in 25 lb. bags, 100 lb. kegs and in barrels of 200 lbs., net. Kept in stock and sold by the leading Seedsmen in America.

USE "SLUG SHOT" FOR SOW BUGS, ETC.

Hammond's Paint and Slug Shot Works
FISHKILL-ON-THE-HUDSON, N. Y.

GREENHOUSES BUILDING OR CONTEMPLATED.

New Britain, Ct.—Arthur Volz, one house.

Great Bend, Kan.—Stoke & Stoke, house 7x60.

Saratoga Springs, N. Y.—C. Delar, house 50x150.

Trinidad, Colo.—Trinidad Floral Co., range of houses.

New London, Wis.—E. H. Olson, range of houses.

Fitchburg, Mass.—W. H. Ritter, range of houses.

Spokane, Wash.—Spokane Nursery Co., range of houses.

Madison, Wis.—Capital City Greenhouses, rose house, 83x100.

Milwaukee, Wis.—W. Edlfsen, one house; J. Rost, one house.

New Orleans, La.—J. T. Dubois, three houses, 12x35, 11x100, 18x100.

The Pulverized Manure Co., Chicago, find the demand for their cattle manure products by the florist and landscape gardener far beyond their expectations, and what they considered would be a heavy stock for the spring trade was depleted materially by the end of January. This being their first year in this line preparations were not made to meet such an influx of trade, but the coming summer they will take the precaution to run their plant night and day and be in readiness for a large winter business.

SPRAY YOUR

FRUIT TREES WITH
TARGET BRAND

Guaranteed Sure Death to

SCALE

1 Cal. to 40 Cals. Water, \$1.00

W. ELLIOTT & SONS

201 Fulton St. New York

PATENTS

Trademarks and Copyrights

Send your business direct to Washington. Saves time and insures better service. Personal attention guaranteed. Twenty-five years' active service. SPECIALTY: "Working on the Failure of Others."

SIGGERS & SIGGERS

PATENT LAWYERS

Box 9, National Union Building
Washington, D. C.

SQUABS

Every man should have at least 10 to 20 pair of the celebrated Plymouth Rock Homer Pigeons or their own Squab raising. It pays and is a pleasure besides. Write the undersigned for prices on mated birds.

THE BEST IN THE WORLD

Jno. A. Kepner, Box 3, Harrisburg, Pa.



The Best Bug Killer and Bloom Saver

For PROOF Write to

P. R. Paethorpe Co.
OWENSBORO, KY.



DREER'S Florist Specialties. TOBACCO SOAP

The best insecticide for house plants known. Is not offensive, easily dissolved and applied. Directions with each package. Doz., \$2.00; 100, \$15.00. Retail at 25 cts.

HENRY A. DREER,
714 Chestnut St.,
PHILADELPHIA, PA.



Cattle Manure In Bags Shredded or Pulverized

Best and safest manure for florists and greenhouse use, absolutely pure, no waste, no danger. Write for circulars and prices.

The Pulverized Manure Co.,
31 Union Stock Yards, Chicago

BOSTON PLATE & WINDOW GLASS COMPANY

GREENHOUSE GLASS---German and American

261 to 287 A Street

BOSTON

20-22 Canal Street

A Good Thing

between faucet and jet is



HOSE

Tested for years and adopted by the

Sunnywoods Greenhouses

The place of origin of the rose BRIDESMAID

MADE IN TWO BRANDS:

Sunnywoods
and
Sunnywoods Extra

In two sizes: — three-quarter and half-inch
In two lengths: — 50 feet and 30 feet
(Both sizes have 3/4 inch couplings.)

PRICES.

"Sunnywoods" — 3/4 inch, 16c.; 1/2 inch, 15c. per ft.
"Sunnywoods Extra" — 3/4 inch, 17c.; 1/2 inch, 16c. per ft.

The material of both brands is of the best. The "Sunnywoods Extra" is the heavier of the two brands.

For the purpose of introduction, this special offer is made:

If you send cash with your order, deduct one cent per foot from the price. And on all cash purchases of more than one hundred feet, freight will be prepaid.

FRANK L. MOORE
CHATHAM, NEW JERSEY
NEW YORK OFFICE, 57 West 20th Street

ANCHOR GREENHOUSE HOSE
WEARS WELL.
PLANT BED CLOTH
Protects from Cold and Dampness.
MINERALIZED RUBBER CO.
18 Cliff Street New York

STANDARD FLOWER POTS
Packed in small crates, easy to handle.

Price per crate		Price per crate	
1500 2 1/2 in. pots	\$4.88	120 7 in. pots	\$4.2c
1500 2 1/4 "	5.25	60 8 "	3.00
1500 2 1/2 "	6.00	HAND MADE	
1000 3 "	5.00	48 9 in. pots	\$3.6c
800 3 1/2 "	5.80	48 10 "	4.80
500 4 "	4.50	24 11 "	3.60
320 5 "	4.51	24 12 "	4.80
144 6 "	3.16	12 14 "	4.80
		6 16 "	4.50

Seed pans, same price as pots. Send for price list of Cylinders for Cut flowers, Hanging Baskets, Lawn Vases, etc. Ten percent. off for cash with order. Address Hillfinger Bros., Pottery, Fort Edward, N. Y. August Folker & Sons, Agts., 31 Barclay St., N. Y. City.

Holds Glass Firmly
See the Point at PEERLESS
FULL SIZE No. 2

Glassing Points are the best. No. rights or 100c. Box of 1,000 points 76 cts. postpaid.
HENRY A. BREER,
714 Chestnut St., Phila., Pa.

The FLORISTS' HAIL ASSOCIATION OF AMERICA, insurer of 28,000,000 sq. ft. of glass. For particulars address John C. Esler, Sec'y, Saddle River, N. J.

GREENHOUSE GLASS

Cheaper Now Than For Years

We are taking contracts for next Spring delivery.

WRITE FOR OUR PRICES

STANDARD PLATE GLASS COMPANY

26-30 Sudbury St. 61-63 Portland St.
BOSTON, MASS.

GLASS

Greenhouse and Hot Bed

SIZES OUR SPECIALTY
IMMENSE STOCK

Plate and Window Glass
Write us for Our Prices.

PARSHESKY BROS.
59 Montrose Ave., BROOKLYN, N. Y.

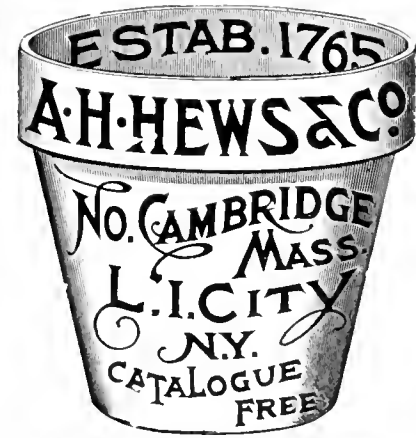

Standard Flower.. POTs

If your greenhouses are within 500 miles of the Capitol, write us, we can save you mooney

W. H. ERNEST
28th and M Street WASHINGTON D. C.

JOHN A. PAYNE GREENHOUSE

Designer & Builder
260-274 Culver Ave.
JERSEY CITY, N. J.

IRON FRAME
SEMI-IRON FRAME
TRUSS ROOF
WOOD FRAME

Material Only or Erected
Everything for the Greenhouse

CYPRESS SASH BARS
82 feet or longer
HOT BED SASH
PECKY CYPRESS BENCH LUMBER

GREENHOUSES
ERECTED AND EQUIPPED COMPLETE IF DESIRED

Write for Circular "D" and Prices

The A. T. STEARNS LUMBER CO.
NEPONSET, BOSTON, MASS.

In ordering goods please add "I saw it in HORTICULTURE."

S. JACOBS & SONS
Manufacturers of GULF CYPRESS
GREENHOUSE MATERIAL
HOT-BED-SASH & FRAMES
Jobbers in Boilers-Pipe-Fittings and
GLASS on which we can quote attractive prices. Disc on large quantities.
We furnish everything for Greenhouse Building
1365-1379 Flushing Avenue
BROOKLYN, - NEW YORK

SECOND HAND PIPE & BOILER TUBES
Of all sizes, in good condition, suitable for steam purpose, coupled and threaded, for sale at low rates.
5000 feet 1 inch pipe, 3c. per ft.; 5000 feet 1 1/4 inch pipe, 4c. per ft.; 3000 feet 1 1/2 inch pipe, 5c. per ft.; 2000 feet 2 inch pipe, 6 1/2c. per ft.
EACLE METAL & SUPPLY CO.,
Johnson and Union Aves., BROOKLYN, N. Y.

NOW IS THE RIGHT TIME TO FIGURE **MATERIAL** AND PLAN FOR THE BUILDINGS OF THIS YEAR

FOLEY'S QUALITY AND WORK THE BEST. PRICES RIGHT AND LOWEST. ESTIMATES WILL PROVE. TRY US.

Foley Ventilating Apparatus Unequaled
Will ventilate any size of house easily. Send for Circular.

THE FOLEY MFG. CO. Western Ave. 25th & 26th Sts. **CHICAGO**

WILLIAM H. LUTTON

HORTICULTURAL ARCHITECT AND BUILDER

WEST SIDE AVENUE STATION (C. R. R. OF N. J.)
JERSEY CITY, N. J.

Have not been established 50 years, but long enough to convince the wide-awake Florist and Gardener that it is to his interest to place his work in thoroughly practical hands.

(150,000 sq. ft. glass erected in 1907 will substantiate this claim.)

And why not? My material is the best that can be secured. My iron frame construction has every modern feature that years of practical experience can embody.

AND THEN THERE IS THE COST TO BE CONSIDERED.

Why not let us take up this important question now?

IRON PIPE

SECOND HAND

WROUGHT IRON PIPE, for Steam, Water, Gas or Oil, Fences or Posts. All Sizes. Price Low.

GEO. B. DOANE & SON

18 Midway Street, BOSTON
 Telephone, Main 4419

R. TONAWANDA, N. Y.



GREENHOUSE CONSTRUCTION LUMBER

John C. Moninger Co.
 117 E. Blackhawk St., CHICAGO

ISAAC CASSIDY

Summer Ave. & Erie R.R., Newark, N. J.

Write for Prices

GREENHOUSE MATERIAL CONSTRUCTION FITTINGS

Bench Fittings

Material Furnished and Erected

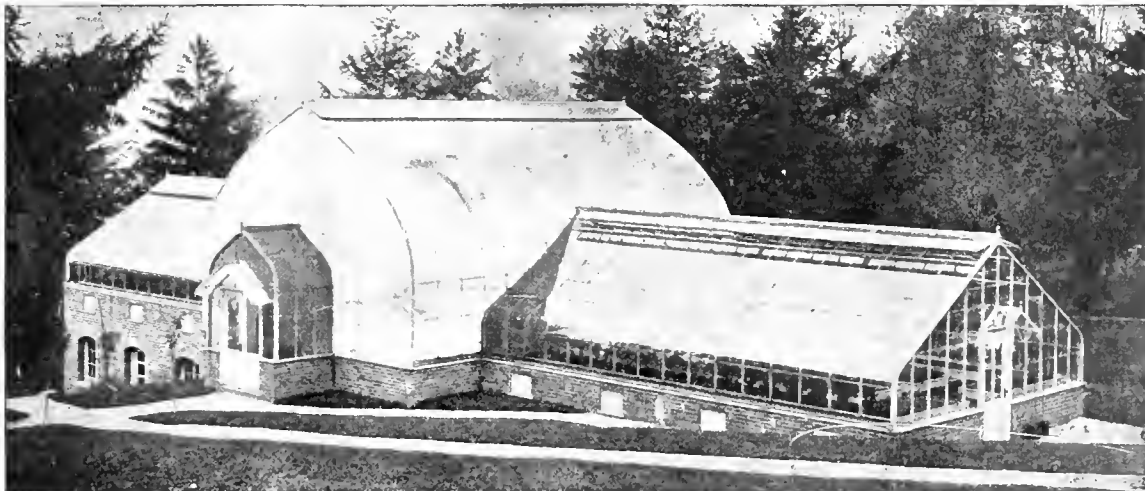

SOLVING LOCATION PROBLEMS

It is not so difficult a matter to build high walls to preserve a uniform floor level where the grounds make a sudden descent, but it is quite another matter to secure successful growing houses where either nearby buildings or trees that the owner will not cut down, shade the houses certain times of the day. It is then that a U-Bar house, because of its extreme lightness, will give to your plants practically the same light that other constructions do in the best of locations. Under any conditions, in any position, U-Bar houses are fully twice as light as any others. Send for catalog.

U-BAR GREENHOUSES

PIERSON



U-BAR CO.

DESIGNERS AND BUILDERS

1 MADISON AVE., NEW YORK

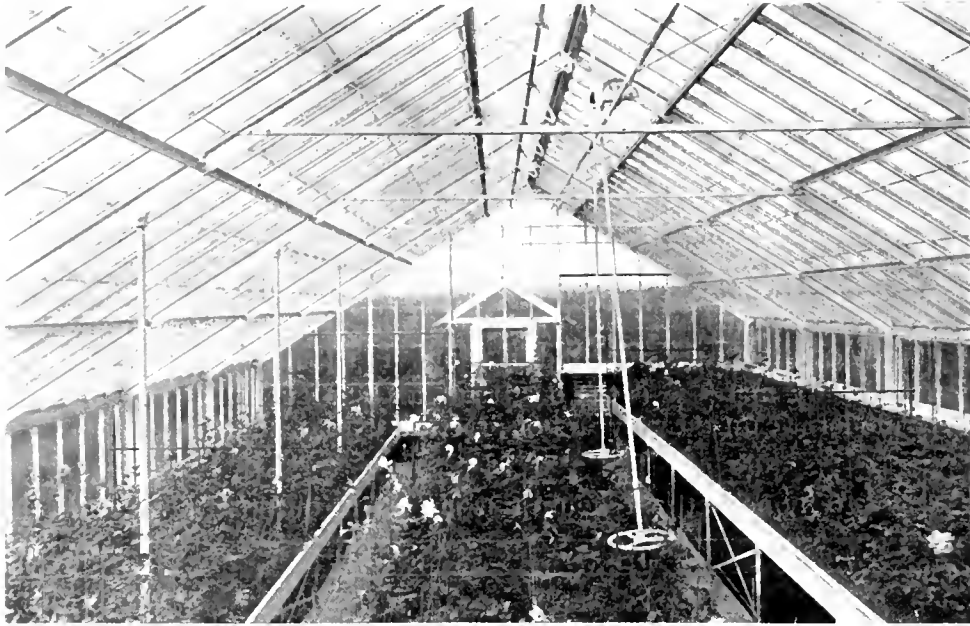

INTERIOR JOHN ASHE ROSE HOUSE

CONCERNING THIS MODEL ROSE HOUSE

HERE then is an up-to-date rose house for private places, one in which from August 1st to February 1st, 11,000 perfect top notch roses were cut from 500 plants.

With this particular arrangement of side-walks three things are accomplished:

All the plants on these 5-foot side benches can be as easily worked as the centre bench.

The plants are far enough from the sides to protect them from chills.

The ventilation following the roof-line and down the sides does not strike directly against the plants, as it does when there is no side-walk, but coming in contact with the heating pipes, reaches the plants tempered. Mildew, the rose grower's bugaboo, as a result is more easily prevented.

Now just take these advantages in combination with our Sectional Iron

Frame Greenhouse, with its exceptional lightness, and absolute *proven durability*, and you have *the* up-to-date rose house.

We have recently printed a book on "Greenhouses As We Build Them," for Colleges, Institutions, Parks and Private Places. We want to send superintendents and gardeners this book, and when writing, it will be a great help to us in completing our list of private places if you will kindly mention employer's name.

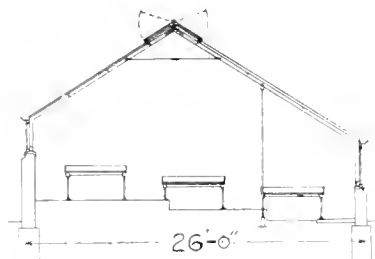

SECTION JOHN ASHE ROSE HOUSE

LORD & BURNHAM CO.

MAIN SALES OFFICE
NEW YORK, 1133 BROADWAY

BOSTON
819 Tremont Building

PHILADELPHIA
1215 Filbert Street

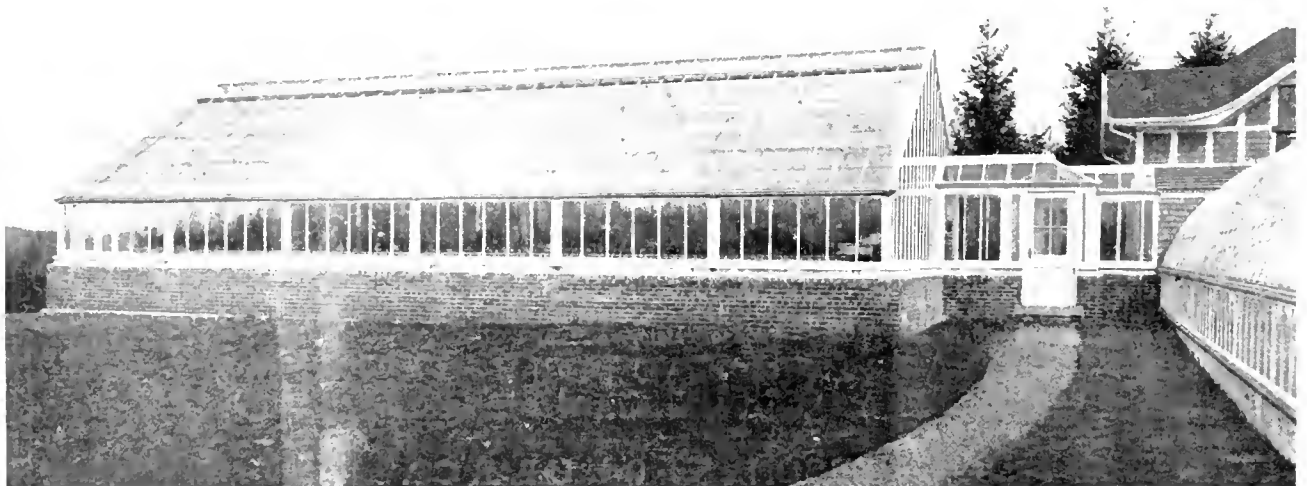

EXTERIOR JOHN ASHE ROSE HOUSE

HORTICULTURE

Vol. VII.

MARCH 28, 1908

No. 13



AUGUST POEHLMANN,
President-elect American Rose Society.

LIBRARY
NEW YORK
BOTANICAL
GARDEN

*Devoted to the
FLORIST, PLANTSMAN,
LANDSCAPE GARDENER
and
Kindred Interests*

*Published
EVERY SATURDAY
At 11 Hamilton Place,
BOSTON, MASS.
Subscription, \$1.00*

CANNA BULBS

Fine plump, Northern Grown, and in fine condition. Not to be compared with Southern grown stock, that are never thoroughly ripened and therefore are very slow to start growing.

	Doz.	100	1000		Doz.	100	1000
Allemania	\$.35	\$2.50	\$22.50	Gladiator	\$0.40	\$3.00	\$27.00
Black Prince	.40	3.00	27.00	King Edward	.50	3.50	32.00
Black Warrior	.35	2.50	22.50	Louisiana	.55	4.00	35.00
Burbank	.30	2.25	20.00	Mad. Crozy	.40	3.00	27.00
Black Musafolia	.40	3.00	27.00	Mlle. Berat	.30	2.25	20.00
Charles Henderson	.35	2.50	22.50	Musafolia	.30	2.25	20.00
Director Roe'z	.35	2.50	22.50	Paul Marquant	.30	2.25	20.00
Flamingo	.30	2.25	20.00	Pres. McKinley	.35	2.50	22.50
Florence Vaughan	.35	2.50	22.50	Queen Charlotte	.35	2.50	22.50
Golden Star	.30	2.25	20.00	Robusta	.30	2.00	18.00
				Red Cross	.30	2.25	20.00

STUMPP & WALTER CO., 50 Barclay St., NEW YORK

GLADIOLI

I can satisfactorily supply your wants for Gladioli for forcing or outdoor planting. Mixtures, color sections or named varieties of exceptional beauty.

Write for Prices

ARTHUR COWEE

Gladiolus Specialist

Meadowvale Farm, BERLIN, N. Y.

COLEUS

Verschaffeltii, Golden Queen, Fire Brand, Lord Palmerston, Queen Victoria, Beckwith's Gem. Prices of Rooted Cuttings by express, 60c. per 100; \$5 per 1000. Less than 250 of a variety will be charged at the 100 rate.

Golden Bedder, Hero, Nessey, Pearl of Orange. 75c. per 100; \$5 per 1000. Less than 250 of a variety will be charged at the 100 rate.

Fancy Varieties. A very fine assortment of twelve kinds not listed above. 75c. per 100; \$6 per 1000. 25n. in assortment, our selection, at the 1000 rate.

MISCELLANEOUS PLANTS

AGERATUM, Stella Gurney, Princess Pauline. SALVIA Splendens, Bonfire, HELIOTROPE. Rooted cuttings, 75c. per 100; \$6 per 1000. ALTER-NANTHERA, Red and Yellow. Rooted cuttings, 50c. per 100; \$5 per 1000.

CARNATIONS

Rooted Cuttings	100	1000
Winsor	\$6.00	\$50.00
White Perfection	2.50	20.00
Rose Pink Enchantress	3.50	30.00
Enchantress	2.50	20.00
Queen Louise	2.50	20.00

From 2 1/4 inch pots, add \$1.00 per 100.

ASPARAGUS PLUMOSUS NANUS SEEDLINGS
From flats, \$1.00 per 1000.

CHRYSANTHEMUMS

Standard varieties, ready for shipment. Rooted cuttings, \$2 per 100; \$15 per 1000. Send for list.

A. N. PIERSON, CROMWELL, CONN.

GLADIOLUS BULBS

100,000, from 1 1/4 inches up @ \$4.00 per 1000
100,000, 3/4 to 1 1/4 inches @ \$2.00 per 1000

Cash with order. Description given on request. Nice block of California Privet, \$10.00 per 1000 and up, as to quality. Write for particulars.

Nice lot of American Chestnut Trees at a bargain. Thirty-five large Sugar trees, most of them sample trees.

I. & J. L. LEONARD, IONA, N. J.

HYACINTHS, TULIPS, NARCISSI AND OTHER BULBS

ROMAN HYACINTHS and the true PAPER WHITE GRANDIFLORA

Ask for our Wholesale Trade List at Hillegom

K. VELTHUYS, Hillegom, Holland
Rep. by FELIX BOSCH, 260 Clarendon St., Boston.

CANNAS

Send for our List and Prices

The CONARD & JONES CO. WEST GROVE, PA.

In ordering goods please add, "I saw it in HORTICULTURE."

LIVE CANNAS

Started from Sand at \$2.00 per 100

Austria, Robusta, Pennsylvania, Chas. Henderson, Italia, Pres. Carnot, Mlle. Berat, A. Bouvier, Duke of Marlborough.

J. B. SHURTLEFF & SON, Cushman Ave., Revere, Mass.

GERANIUMS A splendid stock of fine plants in 2 inch pots, good standard sorts and new varieties at \$2.00 per 100 and up to \$1.00 each. We will send 1000 in 250 good varieties, our selection, for \$13.50. Our special descriptive Geranium Catalogue, describing over 250 varieties of Geraniums and Pelargoniums mailed free to the trade.

PELARGONIUMS In good variety, strong plants from 3 inch pots at \$1.50 per dozen, \$6.00 per 100.

HARDY CHRYSANTHEMUMS Our collection of Hardy Chrysanthemums will compare favorably with any in the country and we have an immense stock ready for shipment. Small flowered or Button Varieties, \$2.00 per 100. Large Flowered or Aster Varieties, \$3.00 per 100. Description will be found in our Wholesale List.

DAHLIA ROOTS We still have about 75 varieties we can offer in Cactus, Decorative, Show and Pompon true to name at \$5.00 per 100 and up for Whole Field-grown clumps. One thousand, so each of 20 varieties, our selection, for \$40.00, all good kinds; a splendid collection for planting or just the thing for Store Trade.

	Per 100		Per 100
Alyssum, Giant Double	\$2.00	Hardy Phlox	2.00
Ageratum, Stella Guroey	2.00	Hollyhocks, Strong 3 in. pot plants, dbl. white, pink, red and yellow	3.00
Begonia, Vernon, White and Rose	2.00	Ivy Leaved Geraniums, 6 good kinds, \$25.00 per 1000	3.00
" Graclis, White and Rose	2.00	Lobelia, Crystal Palace Gem	2.00
Cuphaea, Cigar Plant	2.00	Lantanas, 5 varieties	2.00
Coleus, Verschaffeltii, Golden Bedder and other kinds	2.00	Lavender, 2 1/2 in. pots strong	3.00
Caladium, Esculentum, 1st size \$2.00 per 100; 2nd size	1.00	Panicum, Variegated, Handsome basket plants	2.00
Fuchsias, Black Prince and Minnesota	2.00	Swainsona, Alba	2.00
Lieutenant Muritz, White and Rose Phenomenal	2.50	Salvia, Bonfire and Splendens	2.00
Hardy English Ivy, Extra Strong, \$15.00 per 1000	2.00	Tradescantia, Dark Variegated	2.00
		Verbena, Red, White, Purple and Pink	2.00

R. VINCENT JR. & SONS COMPANY, White Marsh, Md.

YOU WANT THEM NOW

Before the cream of the varieties is all sold. The finest stock of standard

HARDY PERENNIALS

in the country. Write and we'll quote tempting prices.

Red Oak Nurseries, Fiskeville, R. I.

AZALEAS for fall delivery, the best that are grown, also **PALMS** for spring or fall delivery, furnished by August Haerens, Somergem, Belgium; orders booked now....

ADDRESS THE AMERICAN REPRESENTATIVES
AUGUST ROLKER & SONS, 31 Barclay Street, or P. O. Box 752, New York

Decorative Plants

Azaleas, Kentias, Rubbers, Arecas Araucarias, Pandanus, Box Trees, Euonymus, Crotons, and Eurya latifolia.

Extra good value in

EASTER PLANTS

Order Ahead.

A Leuthy & Co.

Perkins Street Nurseries, Rosindale, Mass.

Established 40 Years

Rose Hill Nurseries

New and Rare Plants

NEW ROCHELLE, N. Y.

New York Office, Siebrecht Building, 425 Fifth Avenue

GODFREY ASCHMANN

Importer and Wholesale Grower and Shipper

of Araucaria Excelsa, Compacta, Robusta and Glauca; Keotia Forsteriana and Belmoreana Azalea, Indica, etc. Cultivator of Boston, Scottii, Barrowsii, Elegantisima and Whitmanii Ferns. Ferns for dishes, Cocos, etc. Write for prices.

1012 Ontario St., Philadelphia

HARDY ROSES FOR THE GARDEN

Strong Field-grown Plants

The roses here offered are extra strong two-year-old field-grown blooming plants, which, if planted early, will give a large number of flowers the first year. They can be planted as early in the spring as the frost is out of the ground, and from that time until about the first week in May. We offer a grand collection of the best and choicest varieties, as follows:

HYBRID PERPETUAL OR JUNE ROSES

Frau Karl Druschki, Marchioness of Londonderry, Capt. Hayward, Mrs. R. G. Sharman-Crawford, Ulrich Brunner, Margaret Dickson, Baron de Bonstetten, Paul Neyron, Gen. Jacqueminot Magna Charta, Mrs. John Laing, Mme. Gabrielle Luizet, Marshall P. Wilder, Gloire de Paris, Baroness de Rothschild, Prince Camille de Rohan, Fisher Holmes, Alfred Colomb, Soleil d'Or, Persian Yellow, Moss Roses, Rugosa alba and rubra, etc.

MONTHLY AND HYBRID TEA ROSES

Etoile de France, Killarney, Mme. Abel Chatenay, Countess of Gosford, Koenigen Carola, Perle von Godesberg, Gruss an Teplitz, Maman Cochet, White Maman Cochet, Belle Siebrecht, Hermosa, Mme. Caroline Testout, Souv. de Pres. Carnot, Kaiserin Augusta Victoria, American Beauty, La France, Clothilde Soupert, Prince de Bulgarie, Mme. Norbert Levasseur (Baby Rambler), Anny Muller (Pink Baby Rambler), Catherine Zimet (White Baby Rambler), etc.

In Climbing Roses we have a nice stock of Crimson Rambler, Lady Gay, Dorothy Perkins, Dawson, Gardenia, Tausendschon, etc.

LET US KNOW THE QUANTITY YOU WANT AND VARIETIES, AND WE WILL BE GLAD TO QUOTE LOWEST PRICES ON SAME BY RETURN MAIL.

F. R. PIERSON CO., Tarrytown-on-Hudson, New York

A World Wide Fame

has been attained by the

WALSH RAMBLERS

They represent the highest attainment and progress in garden and forcing roses, being luxuriant, hardy, floriferous and of wide variety of color and form. The report of the Boston Spring Show in this paper shows how **their record previously made is being maintained in the new varieties.** My catalogue and price list, which you may have for the asking, lists the beautiful **Hiawatha**, and its companions, **Delight**, **Coquina**, **Paradise**, **Lady Gay**, etc. Also the best of the Everblooming Hybrid Teas, Hybrid Perpetuals and Penzance Sweet-Briars in strong, field-grown, dormant plants of first quality stock. Double Hollyhocks, Herbaceous Phlox, Paeonies. **Young Ramblers for Next Season's Forcing.**

M. H. WALSH

Rose Specialist

WOODS HOLE, MASS.

Burpee's Two "Unique" New Vegetables, OF UNEQUALED VALUE FOR MARKET GARDENERS

"Fordhook"

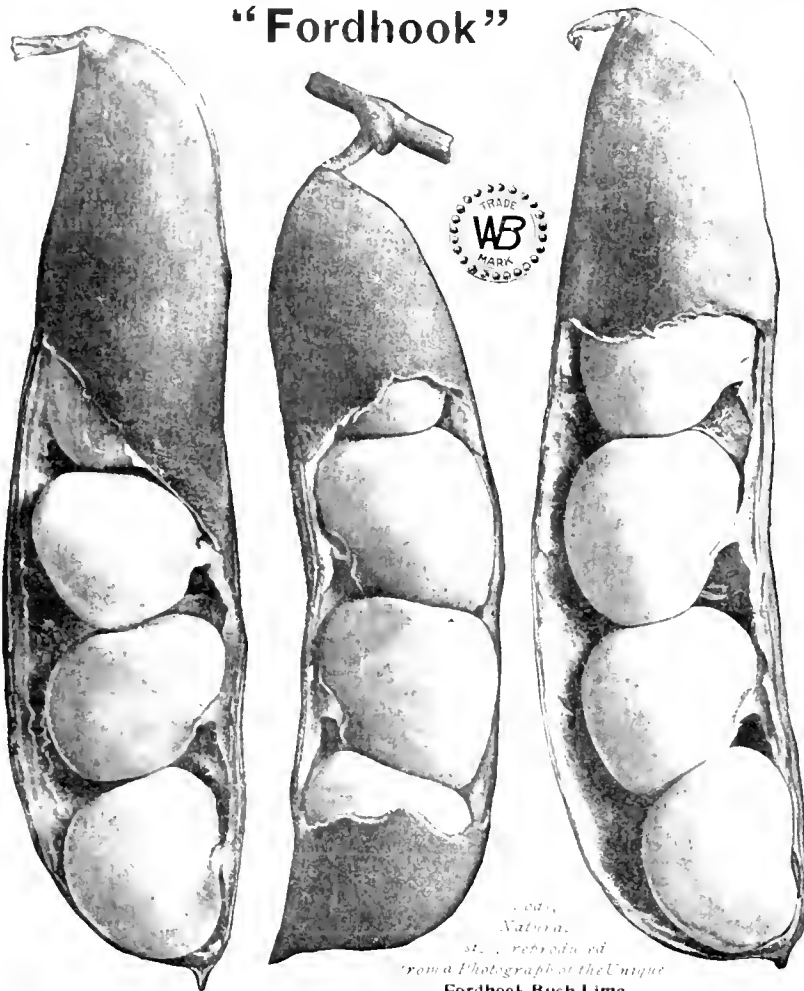

... of ...
Nativa.
St. ... reproducid
from a Photograph of the Unique
Fordhook Bush Lima

FORDHOOK BUSH LIMA BEAN.

The *only* stiffly erect Bush form of the popular "Potato" Lima! Both pods and beans are twice the size of Dreer's Bush Lima and more than half again as large as the Challenger Pole Lima.

FORDHOOK BUSH LIMA is of stitily erect habit, branching freely but with all the branches held upright. This ideal bush growth is strikingly in contrast to the low-spreading growth of the *Kumeler* or *Dreer's Bush Lima*.

FORDHOOK BUSH LIMA has foliage like that of the large pole Limas. The leaves are large, smooth and a dark rich green,—identical with the leaves of *Burpee's Bush Lima*,—as contrasted with the smaller pale green leaves of the *Kumeler* or *Dreer's Bush*.

FORDHOOK BUSH LIMA bears tremendous crops! The beans are ready for use as early as those of *Burpee's Bush Lima*, which furnishes fine Lima beans for the table three to four weeks earlier than they can be had from the earliest pole varieties. The plump well-filled pods are *twice as large* as those of *Kumeler* or *Dreer's Bush*, while the individual beans are fully twice the size. The pods measure four to five inches in length, containing four to five large beans each.

FORDHOOK BUSH LIMA produces such large "Potato Limas" that visitors to our **FORDHOOK** and **SUNNYBROOK FARMS** have been astounded! The beans are very "fat" and lie so closely together in the pod that they are flattened on the ends. The pods are so closely filled that the beans are very easily shelled. **FORDHOOK BUSH LIMA** has an additional merit over all other varieties of the "Potato Lima" type. The green beans, even when of full size, are tender, juicy and sweet in flavor when cooked, resembling the flavor of the finer varieties of large flat Lima,—as distinct from the rather dry and mealy character of all other varieties of the *Potato*, *Challenger* or *Dreer's Lima* type.

FORDHOOK BUSH LIMA under widely varied conditions during the past season (1907), has fully justified all claims made in our introductory announcement last year. Indeed, in habit of growth, great productiveness and fine table quality, it has even surpassed our own expectations. **Per pkt. 10 cts. net; 1-4 pint 30 cts.; 1-2 pint 55 cts.; per pint \$1.00 net.**

"What's in a Name"?

The Name—**Fordhook**—is known to planters everywhere as that of our Pennsylvania farms, so famous as the home of the largest Trial Grounds in America. The name **Fordhook** is widely known, also, as that of the finest extra long *Cucumbers*,—the best all-the-year-round *Squash*,—the earliest large *Watermelon*,—and the most unique *New Bush Lima*. With such a record, our friends will readily understand that when we have a new Musk Melon, of most unusual merit,—upon which we willingly stake our reputation,—we naturally give it **The Name—"Fordhook."**

Burpee's New "Fordhook" Musk Melon.

Fully equals our *Emerald Gem* in delicious flavor. So firm is the rough-netted skin and so solid the thick salmon flesh, that the melons carry to market even better than do *Burpee's Netted Gem*,—the famous "Rocky Ford" Melon.

FORDHOOK MELON is the result of a cross between *Burpee's Emerald Gem* and the *Improved Venus Lind*. As shown by the illustration, it resembles the *Improved Venus* in form; it is equally as roughly netted, while the skin, showing between the netting, is emerald-green. The flesh is very thick, of an attractive deep salmon color and surpassingly sweet to the very rind. It is fully equal in flavor to the *Emerald Gem*. The beautiful salmon flesh, while so surpassingly luscious, is not only very thick, but also extremely solid. The rind, although thin, is unusually firm, so that the fruits carry well to market. There are no musk melons, or cantaloupes, that are better shippers.

FORDHOOK MELON is most vigorous in growth, very early and extremely prolific. The fruits are ready for market fully as early as the green-fleshed *Early Venus Lind*. The vines grow vigorously and each vine sets from five to nine melons immediately around the stem. Frequently the fruits touch one another. The melons are remarkably even in size, weighing from 1 lb. 7 ozs. to 2 pounds each. "Fordhook" is so *thoroughbred* that there are practically no fruits unfit for market. We print letters from the originator and several other growers, all tending to prove that this unequalled new melon is well worthy of the name. **Fordhook** to emphasize that it is "**BURPEE'S BEST**" **CANTALOUPE.**

Per pkt. 10 cts. net; 1-4 oz. 25 cts.; 1-2 oz. 40 cts.; per oz. 75 cts., net postpaid.

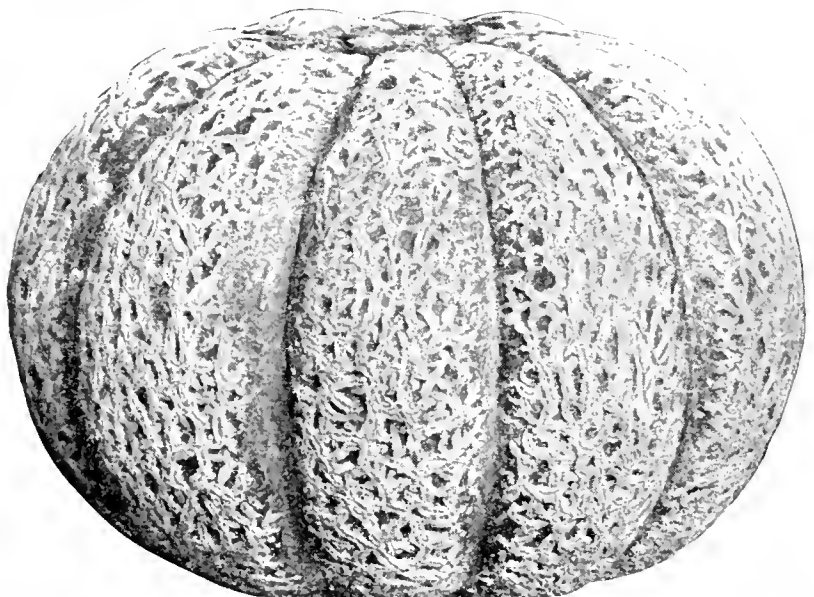

New Musk Melon—Burpee's "Fordhook."—Two-thirds Size, from a Photograph.



✂ If not already received, be sure to send your address to-day for **BURPEE'S "BLUE LIST."** Most complete of all wholesale catalogues for Market Gardeners who plant for profit.

W. ATLEE BURPEE & CO., ... SEED ... CROWERS Philadelphia, Pa.

Echinops—Globe Thistle

My first acquaintance with the globe thistles was made some twenty years ago, while assistant in the Botanical Gardens of the University of Leipzig, in Germany. Of the different varieties in cultivation there it was especially *Echinops ritro*, with its deep, steel blue, ball-shaped flowers, which called forth my admiration. The decidedly ornamental foliage of this hardy perennial adds much to its showiness, and I have often wondered why so attractive a plant species so generally escapes the notice of the landscape gardener and horticulturist, for the instances where I have seen *Echinops* employed to its full advantage are indeed rare.

Globe thistles should never be scattered singly over a herbaceous plantation, but should invariably be massed in groups. A clump of them will always make a good showing, especially on the mixed shrub and perennial flower border, the dark colors, such as *Echinops ritro* and *E. sphaerocephalus*, to my taste being the most preferable. Both varieties, to which, as a third form, we may add *E. tenuifolius* are free branching, reaching a height of from 3 to 3 1-2 feet. *Echinops sphaerocephalus albus* of the same habit of growth bears white

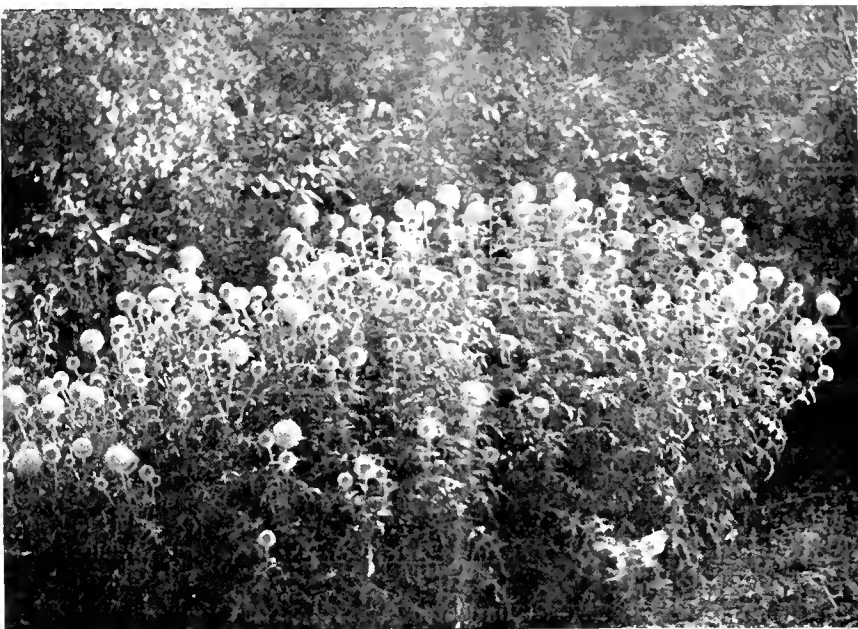

balls, while the tall growing form, *E. giganteus* grows up to the stately height of from 5 to 6 feet.

It is only recently that I have occasionally noticed globe thistles used as they should be, noteworthy in some Bar Harbor gardens. Plant lovers among the society classes are ever alert in recognizing the real ornamental qualities of perennials and *Echinops*, as our illustration shows, possesses those qualities.

Richard Rothe

Notes From the Arnold Arboretum

Though we have had a touch of real spring these last days and in sunny spots crocuses and snowdrops begin to flower, the trees and shrubs show not yet any perceptible sign of life except one shrub which had been in full bloom outdoors in the Arnold Arboretum since the end of January and has stood clothed in a mass of golden blossoms often surrounded by ice and snow and even braving the fierce east winds without damage to its flowers. This remarkable shrub is the Japanese Witch Hazel, *Hamamelis japonica* and particularly its variety *H. japonica* var. *arborea*, in its general appearance very much like our native Witch Hazel, but instead of flowering in autumn the flowers appear in the latter part of the winter or in very early spring and are much more showy on account of their brighter color. The four slender, usually somewhat crumpled petals are bright golden yellow and the small cup-shaped calyx is of a deep claret color inside while outside it is covered with a dull brown tomentum. The leaves hardly differ from those of the native Witch Hazel except that they are somewhat broader and less distinctly toothed.

The typical *Hamamelis japonica*, also sometimes called *H. japonica* var. *Zuccariniana*, has petals of a paler color and the calyx pale purple or only yellowish inside and is of shrubby habit with more upright branches, while *H. japonica* var. *arborea* has bright golden yellow petals and a deep purple calyx; its branches are of slightly darker color and somewhat more spreading and it grows into a small tree up to 20 or 30 feet in height.

Both forms are perfectly hardy here and only in very severe winters have the flower buds been known to be injured, particularly when a spell of mild weather was followed in the latter part of the winter by very severe frost. It is, however, astonishing how much frost the delicate looking flowers can stand. This year, for instance, a few warm days in January were sufficient to induce the buds to burst and to expose the petals, each warmer spell caused them to come out a little further, and there was no sign that the intervening cold waves, even down to zero weather, had any noticeable injurious effect except perhaps that the petals remained a little more crumpled.

Branches cut in midwinter form a very pretty distinctly Japanese-looking decoration for vases; about two days in a warm room suffice to bring out the flowers which exhale a peculiar but faint odor.

It seems strange that such a handsome and interesting hardy shrub, really the only winter-blooming shrubs in our northern latitudes, should be so little known and so rare in our gardens, though it had been introduced into cultivation as far back as 1862 by Siebold. One reason for its rarity may be sought in its slow growth and in its rather difficult propagation which must be effected by grafting in spring on potted stock of the common Witch Hazel in the greenhouse.

Alfred Rehder

HORTICULTURE

VOL. VII MARCH 28, 1908 NO. 13

PUBLISHED WEEKLY BY
HORTICULTURE PUBLISHING CO.
11 Hamilton Place, Boston, Mass.

Telephone, Oxford 292
WM. J. STEWART, Editor and Manager

SUBSCRIPTION PRICE

One Year, in advance, \$1.00: To Foreign Countries, 2.00: To Canada, \$1.50

ADVERTISING RATES

Per Inch, 30 inches to page \$1.00.
Discounts on Contracts for consecutive insertions, as follows:
One month (4 times) 5 per cent.; three months (13 times) 10 per cent.;
six months (26 times) 20 per cent.; one year (52 times) 30 per cent.
Page and half page spaces, special rates on application.

Entered as second-class matter December 8, 1904, at the Post Office at Boston, Mass. under the Act of Congress of March 3, 1879.

CONTENTS

	Page
FRONTISPIECE—August Poelmann, portrait	
ECHINOPS—Richard Rothe—Illustrated.....	401
NOTES FROM THE ARNOLD ARBORETUM—Alfred Rehder	401
BRITISH HORTICULTURE—W. H. Adsett.....	403
THE PRESENT CARE OF THE HERBACEOUS BORDER—Frederick J. Rea.....	403
SPRING SHOW AT BOSTON—Illustrated.....	404
AMERICAN ROSE SOCIETY	
The Annual Meeting—President's Address.....	406
Secretary's Report—Treasurer's Report.....	407
Thursday Morning Session—Buffalo the Next Meeting Place—The Election of Officers—The Exhibition	408
NEWSPICES OF THE CLUBS AND SOCIETIES	
Gardeners' and Florists' Club of Boston—Society of American Florists—New Haven County Horticultural Society—American Society of Park Superintendents—Florists' Hail Association—Chicago Florists' Club.....	408
National Horticultural Society of France—National Chrysanthemum Society of England.....	409
Club and Society Notes.....	421
OBITUARY—William H. Spooner, portrait—J. M. Gasser, portrait—E. J. Castle—John Moller—C. T. C. Deake—James P. H. Ruth—E. D. Darlington—Joseph Kaiser—Alfred Hildred.....	409
SOME NEW THINGS IN AN OLD COUNTRY—J. Otto Thilow.....	410
SEED TRADE.....	414
LIBRARY NOTES—C. Harman Payne	416
OF INTEREST TO RETAIL FLORISTS	
Chicago—Detroit—New Retail Flower Stores.....	418
FLOWER MARKET REPORTS	
Boston, Chicago, Indianapolis, Philadelphia, Twin Cities, Washington.....	421
MISCELLANEOUS	
The Perkins Seedlings to be Propagated.....	405
Plant Imports.....	412
Catalogues Received.....	414
Trip to the Ghent Quinquennial.....	415
A Great Aster.....	418
Incorporated	418
News Notes.....	418, 419, 421
Business Changes.....	419
Personal	419
Notes from Twin Cities.....	421
During Recess.....	421
List of Patents.....	429
Greenhouses Building or Contemplated.....	430

hadn't the heart to do any dissecting and concluded that after perusing it our readers would agree with us that we had made good use of our space in giving them Mr. Thilow's observations practically as presented by him to the Philadelphia club.

Reporting the exhibition

In liability to criticism the reporter stands a good second to the judges in dealing with the exhibitors at a large show. Woe be unto him who in his

story of the exhibits and the awards inadvertently overlooks an item, however small. In fact, the small contributor is the more exacting. But, as all newspaper men know, it is a question how far it is wise to try to go in the publication of unimportant items in awards, etc., which contain nothing of general interest. Just why, for instance, a man would feel slighted because of omission to record the fact that he had been given a third prize, is rather hard to understand; to the uninitiated it would seem that he should be grateful if accorded obscurity under such conditions. But large exhibitions are coming with increasing frequency, while the problem of stretching paper pages still remains unsolved in the editorial cloister and while this fact remains we hope that forgiveness and free absolution will not be withheld from the man with the scissors.

The remedy

Many an anxious business man is wishing today that he could peer into the future and have some foreknowledge of how the commercial situation will shape up for the coming season. That we are only entering upon the beginning of a year's business depression in horticultural industries is a view one hears frequently expressed by men whose wide experience and keen instincts entitle them to something more than a mere hearing. These observers tell us that we need look for little improvement in trade conditions until after the approaching political contest has been settled. On the other hand we find some—but we confess they are in the minority—who point to the fact of our great agricultural prosperity, our unlimited resources and who draw from this and other premises the reassuring sequence of returning confidence and reviving activity. No doubt, if there was less pessimistic talk, prosperity would be more quickly achieved, for there is no question that a restoration of the good times of a year ago rests mainly with ourselves. Depressing expressions and gloomy forebodings do much to aggravate and prolong dullness. A gleam of light indicative of the dawn of a brighter day has already come from the seedsmen who report trade better than they had expected it to be and actually showing a substantial gain over last year. For the nurserymen we predict a like experience. The country was never more solvent than it is today and the majority of the nurseryman's patrons will order their regular quota of stock for ornamental as well as for economic purposes—possibly more of the latter. The florist, too, will have his share, for his products have now become a necessity with most of the people. Fortunately for all those who deal in goods horticultural, the existence of such a paper as HORTICULTURE affords an unexcelled means of promoting business, accelerating the movement of material and providing every one with something to do, through a liberal use of the cheap but potential medium for wide publicity afforded by its advertising columns. In other words, HORTICULTURE's prescription for this business interruption is, Advertising, in big and frequent doses. The time has really come for us to resume our normal course.

A story well told

We present in this issue the first installment of the delightful account of a brief European trip, read before the Philadelphia Florists' Club by J. Otto Thilow. It was our purpose, owing to the length of the paper and our limited space to exercise our editorial prerogative and, selecting some of the most interesting points touched upon by Mr. Thilow, make a summary which would come within our limits but found ourselves so absorbed in the story so entertainingly told that we

British Horticulture

NEW SWEET PEAS

As previously indicated in these columns, there is a useful batch of sweet pea novelties available this season. Hybridizers in this direction are still actively engaged in seeking to further perfect this increasingly popular annual. Amongst the firms who are making a special line of this branch are Messrs Watkins & Simpson of 12 Tavistock street, Covent Garden, London. Mr. Alfred Watkins has been President of the National Sweet Pea Society, and he is a member of the Executive Committee of that organization. The members of the society who paid a visit to the firm's local grounds at Twickenham in 1906 were able to judge of the extreme care which is taken to ensure the varieties being sent out properly fixed in character. W. Atlee Burpee, who inspected the nursery last summer, was considerably impressed with the splendid display of bloom on the firm's ground. Messrs. Watkins & Simpson have this year a very useful selection which will evidently secure many admirers on both sides of the Atlantic. These are of the giant-flowered type, with the many standards now so popular amongst exhibitors. Gladys Unwin has already established itself in public favor amongst market florists. Nora Unwin shares with Dorothy Eekford the honor of being the best white in the National Sweet Pea Society's list. Phyllis Unwin is a deep rosy carmine self. The other new comers offered by the firm comprise: A. J. Cook, violet mauve self; Frank Dolby, pale blue; Mrs. Alfred Watkins, pale pink, with salmon shading; E. J. Castle, carmine with salmon shading; Evelyn Byatt, flame tint. Nora Unwin received an award of merit at the National Society's trials at Reading last summer.

THE WINTER FLOWERING CARNATION SOCIETY

An attractive schedule has been issued for the spring show of this society which will be held on April 1st. On the same day the annual meeting will be held, at which a scheme for the registration of new varieties will be presented. P. Smith of Modstead will deliver a lecture on the afternoon of the show on "The present and future of the winter flowering carnation." The floral committee have arranged to award certificates of merit to new varieties. In order that a full opportunity may be afforded of the form and habit of the variety those plants in bloom will have to be shown besides the cut flowers. It is arranged that a variety must gain at least 30 points to entitle it to a first-class certificate and 25 points to entitle it to an award of merit. Five points will be allotted for each of the following qualities: color, size, fragrance, substance, calyx, general appearance, length and substance of stem, and habit of plant.

Leading growers are this season offering Mrs. H. Burnett, salmon; Aurora, buff, flaked pink; Mikado, heliotrope; Ceres, yellow, flaked salmon pink; and Marmion, cherry, picoteed with white. The last named received an award of merit from the Royal Horticultural Society and a first-class certificate at the Southampton show last year. An English grower has produced a rival to Mrs. T. W. Lawson, named Evelyn Davy. Although a trifle smaller than the famous American variety it is claimed to produce four times the number of blooms. The color is described as a vivid rose cerise.

A NEW FERN

In the hardy exotic house of one of our largest fern growing establishments is to be seen *Osmunda palustris*

Mayi. This was exhibited at the Holland House show, and received a first-class certificate from the Royal Horticultural Society. The normal variety is quite plain, but in this one all the pinnules are twisted and semi-erected. It was obtained from one of the hardy exotics grown in Brazil. Many varieties that come from tropical countries like Brazil are hardy in England, but the ferns from which *Osmunda Mayi* was raised were found on a mountain. There appears to be an increased interest taken in fern culture on this side. Some meritorious displays are often made at the leading shows by the florists making a specialty of this branch of horticulture. A useful handbook on all phases of fern culture is now being prepared for publication by a leading firm of London publishers.

W. H. Adsett.

The Present Care of the Herbaceous Border

Everywhere we turn we hear the query, "How have your perennials come through the winter?" and the chances are that the answer will be: "They are looking fine; better than we expected, after such a changeable season." But take care; you may be deceived. Everybody that has grown perennials for a few years knows that more losses occur from now until the tenth or fifteenth of April than at any other time. But those that have just started a collection, either last spring or last fall, are the ones that should be warned.

Let us divide a general collection into two sections. First, those that have foliage above ground all winter. It is a curious fact, and one not generally thought of, that all plants in this section, with few exceptions, have fibrous roots, which enables the plant to stay well into the soil, so we do not cover these to keep them from lifting but to keep the foliage and crowns from the sun. Second, those that have their dormant crowns more or less under the ground; and a great many of these have tuberos, or thick, fleshy roots, which lose their fibres in the fall, so readily lift out enough to expose their crowns. These have to be covered to prevent this lifting. In other words keep frost in the ground as long as possible.

Now, according to my experience, losses will be greater during the next three weeks than at any time during the winter; and there are reasons enough. For example, March thirteenth and fourteenth were warm and springlike, and the fifteenth a thunderstorm, then on the morning of the seventeenth the thermometer registered eighteen above and on the eighteenth a snow-storm. All this is likely to happen three or four times before it is safe to expose plants to bright sunlight; for it is the hot sun in combination with the cold nights that does the killing.

So, because we have two or three warm days, do not uncover your plants, but wait till the frost is out of the ground where covering has been done. By doing this you will be wise and bring losses down to a minimum.

Frederic J. Pea.

SPRING SHOW AT BOSTON.

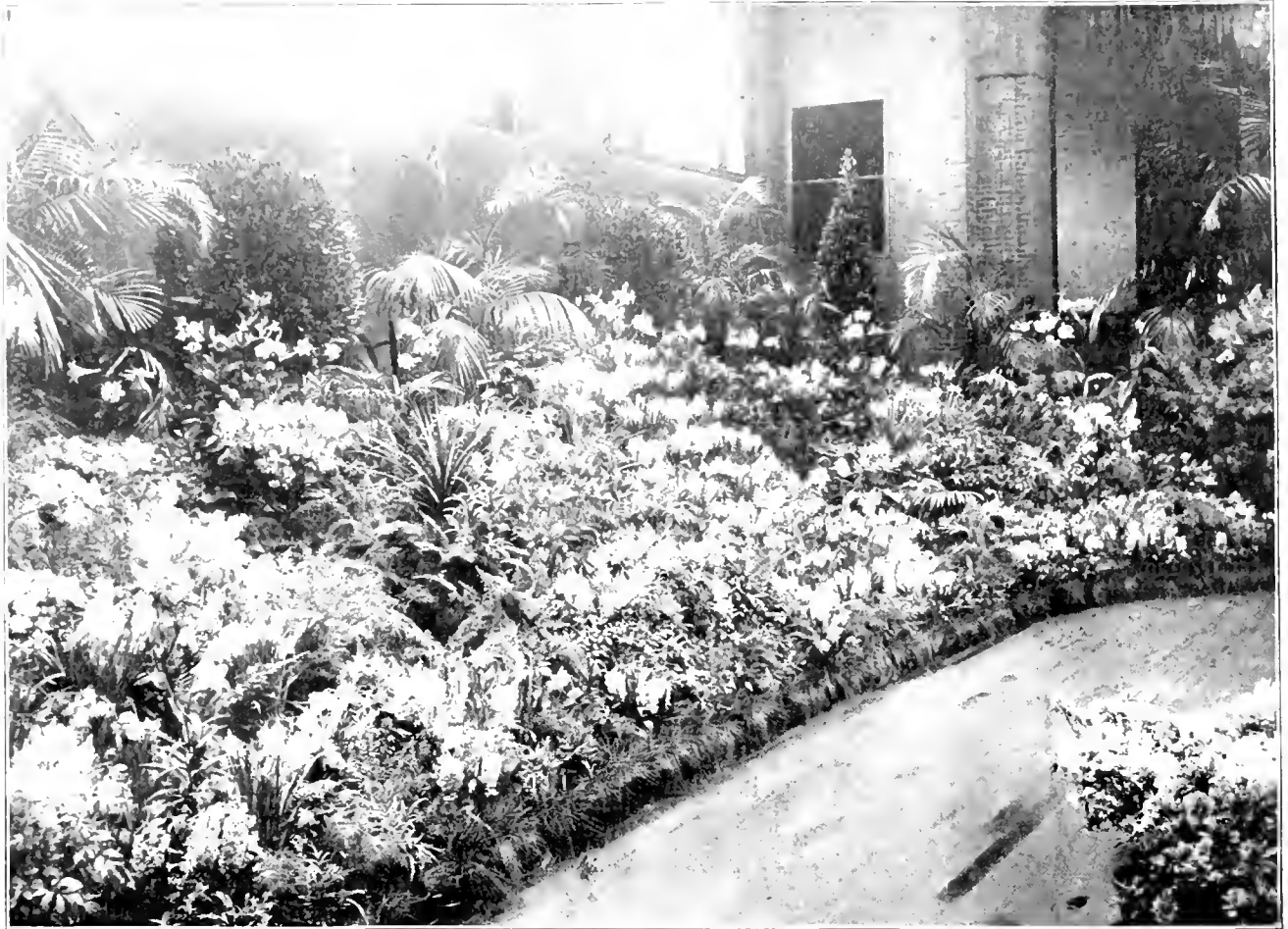

THE FARQUHAR GROUP.

Boston's great spring show is now a thing of the past, but it will long live in the memory of those who were privileged to see it. When we say it was a great show we know we are but repeating what has always been said by somebody about all spring shows, but in this case the phrase means all it suggests, for it was in respect to quality in most lines, attendance and more distinctly in brilliancy, finish and quantity it excelled anything in the spring show line for a long time.

Whether we take into consideration the exquisite sweet pea display of Wm. Sim, the superb ranibler roses of M. H. Walsh, the beautiful array of over two hundred vases of rare orchids from J. E. Rothwell, the gorgeous collection of seedling amaryllises from T. D. Hatfield, the comprehensive display of narcissi from Wm. Whitman, or the wonderful cyclamens shown by Dr. Weld, W. A. Riggs or E. J. Mitton, the high quality of the show is evidenced by either of these individual factors, and

when we recall the grand massing of white, purple, yellow and green in the unprecedented group of spring flowering plants from R. and J. Farquhar & Co., which is shown in the above illustration, and which won the rare honor of a gold medal, it tells the story of spring's exuberance in no uncertain language. In fact the large exhibition hall was a riot of color, in azaleas, acacias, genestas, lilies, rhododendrons, lilacs and primroses in a setting of palms and ferns; the small hall was equally brilliant with orchids and thousands of narcissi and the large lecture hall with its ranks and ranks of carnations, roses, sweet peas and collections of bulbous material was a scene of floral beauty not soon to be forgotten.

Among the things worthy of special mention in addition to those above alluded to were the following: A fine group of palms and Easter flowering plants, effectively arranged, from Edward MacMullin; a group of rare palms, arranged with ferns, primroses, acacias and genestas from the Harvard Botanic Garden, attesting to the rare skill and taste of Robert Cameron; specimen ericas and acacias from Mrs. Fred Ayer; cinerarias, stellata and florists' varieties, from Wm. Whitman; W. A. Riggs' big array of narcissi and other bulb flowers, which won the Rawson silver cup; schizanthuses amaryllises and bulb flowers from Mrs. J. L. Gardner; orchids from



GROUP OF ORCHIDS FROM SETH A. BORDEN.

Seth A. Borden, especially rich in dendrobiums; roses from Waban Rose Conservatories and W. H. Elliott, the former beating on Killarney and the latter on Richmond; also the roses from Montrose Greenhouses including Brides, which won first prize; a gorgeous group of Chorizanthe glauca from Mrs. J. L. Gardner, plants four feet through; a very effective group of genestas in trained forms from Thomas Roland; anemusas from W. W. Rawson & Co., and enough carnations to make an excellent exhibition all by themselves contributed by S. J. Goddard, M. A. Patten, Wm. Whitman, Mrs. J. C. Phillips, Ellen A. Mansfield, Backer & Co., R. D. Kimball, Chas. Strout and others whose names will appear in the following special mention. A. Roper's leviathan Bay State, which makes a sensation wherever shown, got a silver medal; W. A. Manda's seedling Number 20 was given honorable mention; Afterglow, shown by Wm. Nicholson & Son, won a silver medal; E. A. Wood's new carnation, Mrs. Geo. A. Frost, was awarded a certificate. Among seedling carnations shown were Ruth Hayes, a crimson from H. A. Stevens, a white and a scarlet from Backer & Co., Edward, a pink from W. H. Shumway, a crimson from M. A. Patten and Priscilla, S. J. Goddard's handsome variegated. Helen Goddard stood out well among the standard varieties.

Certificates of merit were given to Wm. Sim for the following varieties of sweet peas: W. W. Smalley, pale salmon; Mrs. Alex. Wallace, lavender, Le Marquise, purple and blue. Among the rambler roses shown by M. H. Walsh were Arcadia, a densely double dark crimson, which received a silver medal; Excelsa, a large petalled double crimson, the progeny of Gen. Jacquemot and Crimson Rambler, which won a certificate of merit, Celeste, which got honorable mention, Posey, double pink, Lucinda, single pink, Jewel, single light pink, Lady Gay, Hiawatha, La Flame and De-



GENERAL VIEW OF PART OF MAIN HALL.

light. J. L. Smith, gardener for Mrs. A. W. Blake, received a cultural certificate for an enormous specimen of *Nephrolepis Barrowsii*, which was commented upon as one of the most striking specimens shown in many years. Wm. Downs also received a cultural certificate for a vase of handsome yellow snapdragon. Honorable mention was given to F. C. Green for pink Roman hyacinth Excelsior; to W. A. Manda for *Asparagus elongatus*; W. W. Rawson for *Lobelia Kathleen Mallard*; H. A. Dreer for *Blush Queen Alexandra marguerite*, and Walter Hamewell for annual chrysanthemum Evening Star. Violets were well shown by Wm. Sim, H. F. Woods, H. F. Calder and Estey Bros.

The lecture hall stage was filled with

a fine plant group by Gen. S. M. Weld. In the vegetable classes a silver medal for superior cultivation was given to F. E. Cole. V. Butta showed some novelties in salad greens.

THE PERKINS' SEEDLINGS TO BE PROPAGATED.

Our readers will be interested to know that Mr. T. E. Perkins, of Red Wing, the originator and owner of the famous collection of seedling apples known as the "Perkins' Seedlings", has disposed of a number of the best of them to some of the nurserymen of the State, by whom they will be propagated, and as soon as possible put upon the market. There are in this noted collection many long-keeping varieties, and some of excellent quality. Probably no seedling orchard in this country has aroused more interest than the one referred to. Since it came into bearing, some ten years ago, the fruit from this orchard has been exhibited repeatedly at our state fairs, 100 and more varieties, and the interest in this exhibit is fully maintained, notwithstanding it has been now so many times repeated. A very full exhibit of the collection, made by Mr. Wyman Elliot, at the American Pomological Society meeting in Boston some years since, received in recognition the Wilder medal, and was looked upon with astonishment by our brothers in the east. Grown as they are from the seed of one lot of Malinda apples, evidently crossed with a number of other varieties, there is such a uniform hardness, freedom from blight, and other good qualities in the collection as to mark this orchard as one of the remarkable horticultural phenomena of the times.—Minnesota Horticulturist.

Winter is past; the heart of Nature warms Beneath the wrecks of unresisted storms; Doubtful at first, suspected more than seen, The southern slopes are fringed with tender green. —Holmes.



MACMILLIN GROUP AND PART OF WALSH EXHIBIT.

AMERICAN ROSE SOCIETY

Annual Exhibition and Meeting Held at Art Institute, Chicago, Ill.

Buffalo To Be The Next Meeting Place

Officers Elected

PRESIDENT—August Poehlmann, Morton Grove, Ill.; **VICE-PRESIDENT**—W. F. Kasting, Buffalo, N. Y.; **SECRETARY**—Benjamin Hammond, Fishkill-on-Hudson, N. Y.; **TREASURER**—Harry O. May, Summit, N. J.; **EXECUTIVE COMMITTEE**—E. Gurney Hill, Richmond, Ind.; P. Welch, Boston; Peter Bisset, Washington, D. C.; A. Farenwald, Roslyn, Pa.; P. J. Lynch, West Grove, Pa.; J. J. Curran, Salem, Va.; Philip Breitmeyer, Detroit.

The American Rose Society convened at 8.30 o'clock Wednesday evening, March 25, with a fair representation of members present, mainly from other cities in the beautiful lecture hall of the Art Institute, Chicago. President Simpson read the following address, which was received with appreciative applause:

President's Address.

Ladies and Gentlemen, Fellow Members of the American Rose Society:—Another year has rolled around and we again meet in our annual convention to look and talk over the work of the year that is past, and to plan the policy and work of the Society in the future.

Last year we met in the capital of our country, and many of us felt honored by having the privilege of taking the hand of the President of the United States in curs and receiving his kindly greeting and good wishes for ourselves, and noting his appreciation of the work being done by the Rose Society and many of the individual members. It was said by many of our members that the Washington meeting was in many respects more enthusiastic, and gave promise of larger permanent results than any of its predecessors.

This year through the generous invitation of the Chicago Florists' Club the American Rose Society plants its banner in the city of Chicago, the great and magic city of the West, where more roses are produced under glass, and distributed from this point over a larger area, than perhaps can be said of any other center in the country, not even excepting the city of New York. It seems therefore eminently fitting that this society should honor this city and this rose growing centre by holding its exhibition and convention here this year. Many of you have seen the splendid exhibitions given in the city of Chicago in the past and have felt certain that the rose exhibition this year would be a distinct advance over anything hitherto attempted or seen in this city of big things.

I wish most heartily to express my appreciation of the work done by the Chicago Florists' Club and the Rose show committee appointed by the club to secure special premiums and arrange the many details incident to an

undertaking of this kind. When we remember that the local florists have on their hands and minds the National Show to be given here next November, and that they will have to give much of their time and means to put it through in a manner befitting the occasion and the scope of the undertaking, we are constrained to take off our hats to the men who have secured such an array of special premiums as our list shows, and have made possible such a splendid exhibition as that we have seen today.

The meeting of our society here in this western centre, for the first time in its history, is a good augury for the future of the society, I am very sure; we shall miss a good many faces here that have become familiar through meeting them so frequently at the annual gathering in the East, but we are to make new friends that will join with the old in making this society a tower of strength, and make it truly national in scope and character as well as in name.

Use of the Society.

In seeking to make recruits to our organization one frequently hears the remark, "What is the use of having so many societies anyway, and what benefit would it be to me if I should join the American Rose Society?" The only answer that I can give is, "That practically every grower of repute who has had his attention called to the aims and purposes of this organization has become a member of it, and if we give the matter a very little thought we will find that, with a very few exceptions, the men who hold aloof are back numbers in the trade. You will find that the brainiest and most progressive men in the business today are members of the Rose, the Carnation, the Chrysanthemum, or some other society devoted to their specialty. An orchid society is now being projected as a necessary adjunct to the orchid business. Read the printed matter on the back of the Rose Society's letter paper and you will find "Its aim is to increase the general interest in the cultivation and to improve the standard of excellence of the rose for all the people; to foster, stimulate and increase the production in every possible way of improved varieties of the rose suitable to our American climate and

requirements." A very noble aim this surely, and one that should naturally inure to the benefit of every man engaged in the growing or selling of roses for a living. The annual exhibitions, affording as they do to raisers of new roses the very best opportunity of getting their novelties before a critical tribunal, and the opportunity offered the searchers for novelties to see these and judge of their merit is a very important feature of the work of such societies; and the man who follows up these exhibitions and has the judgment to discern the good and bad points of both new and old varieties, and will gauge his planting accordingly, discarding the varieties that have become old and common and giving space to newer sorts of undoubted merit, is the man who will have money to build more greenhouses and buy automobiles. Very few of the visitors to the Washington or Boston exhibition returned home without receiving inspiration to strive for a higher grade of flowers as the product of his skill, with the feeling of satisfaction with his calling, and with a determination to add dignity to it, and to make his business stand for something in the community.

The Work Ahead.

The Rose Society certainly claims a share in the good work of making conditions more favorable for the rose grower of today. What has been done up to the present, however, is as nothing compared to the work that lies before it when with increased membership and available funds it is in a position to disseminate knowledge that will enable lovers of the rose, and that includes practically every citizen of this country, to plant varieties, and cultivate them in such a way as to give joy and satisfaction to the planter. There will then be sold by the nurseryman and florist for outdoor planting more roses than we can at present conceive of, and the prophecy will be fulfilled: "The desert place shall rejoice and blossom as the rose."

More has been done during the term of our present secretary to put the society upon a sound and permanent basis, and to present its claims and benefits to the florists of the entire country, and to many who do not grow roses for a living than most of you are aware of, the volume of correspond-

ence and the amount of clerical work done would stagger most of us, if it should be put upon us; and he certainly deserves the thanks of every member of this body for his painstaking work, done entirely for love of the good cause, and refusing any pecuniary compensation therefor. During the past year the expenses have been out of proportion to the income, the officers having advanced money to meet obligations and carry on the work, trusting to the receipts of this meeting to balance accounts; failing in this, I suggest that a few friends of the society meet here in Chicago, and together lift the treasury out of its awkward predicament. Certificates for new varieties authorized at our last meeting and life membership certificates have been provided at considerable expense, but we think to the credit of the society. A resolution was favorably received at the Washington meeting requesting the executive committee to consider the proposition of establishing a rose journal. This matter has received considerable thought and discussion during the year at the hands of the committee, and the secretary was authorized to go ahead and issue a prospectus, which has been sent out broadcast and has been commented on very favorably. The secretary will present to you a fuller report on this proposition; I would ask for your careful and thoughtful consideration. If the members will support it in sufficient numbers it can be put through, otherwise it must be dropped.

The June Exhibition.

A committee was appointed to confer with the Association of American Nurserymen relative to the holding of an exhibition of outdoor roses in June, under the joint auspices of the two organizations. Mr. Hill, as chairman, will report on the work of this committee. Through the good offices of our ex-president, Mr. Newbold, an invitation has been extended to the American Rose Society by the Horticultural Society of New York to hold a June show this year in Bronx Park, New York City; the latter society to furnish the money and take care of all the details, and our society to offer certificates, medals, etc., and assist in arranging the schedule. The offer was accepted and the exhibition is assured, but the executive committee of the Rose Society authorized the offering of certificates, bronze and silver medals for new varieties only. It is the wish and desire of the members of the committee that the nurserymen, and all others who grow outdoor roses extensively, will keep this exhibition in mind and arrange to make extensive displays of roses in Bronx Park next June. The educational features of such an exhibition, that is free to all, should be very great, and as an advertising medium it is not to be despised.

In arranging the program for this meeting the commercial rose grower has perhaps been brought to the front more than the amateur, which probably is as it should be at the present stage; but it will not do at all, I think, to allow this society, now, or in the future, to drift into a trade organization and have its work restricted to the holding of exhibitions and exploiting of new varieties; that would be praiseworthy work, but it can do that

and a great deal more by opening wide its doors, and seeking the co-operation of every man and woman in this broad land who has roses in his heart or in his garden. We should have in our ranks every authority on roses in the country, and the secretary should have a list of these authorities to whom he could refer questions that are too difficult for him to handle.

Finally, gentlemen, let us take a wide outlook; let us be broad in our views, and in our discussions at this meeting let us be considerate of each others' feelings, remembering that we have but one object in view, the placing of the rose on the pedestal where she rightfully belongs, and the ennobling of our calling and profession.

Secretary Hammond then read the minutes of the last meeting and presented his annual report.

Secretary's Report.

The Secretary first and foremost desires to publicly acknowledge the value of the service rendered by the four trade papers, "American Florist," "Florists' Exchange," "Florists' Review," and "Horticulture," named in order of their age, for the courteous consideration which one and all have given to matters pertaining to the American Rose Society. It has been the effort of your Secretary to get as much publicity as we could, because this Society was founded with the idea of its becoming an extensive popular association to spread the love of the beautiful rose among the people.

And another important fact is that the work of co-operation and patronage incumbent upon a national society cannot be done unless the society is provided with revenue, and the revenue depends upon its membership. The American Rose Society should be able to patronize local societies by offering its medals freely, but all this takes revenue. The life membership fund gradually increases, affording a revenue of 4 per cent, on the investment per annum, and the fund is now close to \$3,000.

The money awarded by the Society at its last show reached the sum of \$309.00 for stated premiums besides the special premiums. The Bulletin of the annual meeting which was begun under Secretary W. J. Stewart's term of office has been continued and 600 were issued. These books seem to be highly appreciated, secretaries of kindred societies asking for them in various instances. To get out these books nicely is considerable expense, and part of this cost was met by soliciting a half or full-page advertisement; out of 60 letters sent out, favorable replies came back.

At the Washington meeting last March the desirability of issuing a certificate of merit for new roses which did not reach the score required for such novelties to win a society medal, was discussed and recommended. The Executive Committee acting upon that recommendation prepared such certificates and issued seven: E. G. Hill Co., Richmond, Ind., "Rhea Reid"; F. H. Kramer, Washington, D. C., "Queen Beatrice"; Myers & Santman, Wyndmoor, Pa., "Wyndmoor"; M. H. Walsh, Woods Hole, Mass., "Paradise," "La Fiamma," "Delight" and "Junjata." This recognition seemed to please everyone.

Up to last year there had not been any certificate of life membership nor any society seal; a handsome certificate was made, a special seal prepared and adopted, and 51 of these life certificates have been issued to persons who have paid the \$50.00, which is the amount that is creating the permanent fund of the Society. The certificate was sent to the family of deceased members.

The American Rose Society has been invited to hold a June Show in the Botanical Garden in Bronx Park, New York City, in connection with the New York Horticultural Society. Ex-President Frederick R. Newbold attended one of the executive committee meetings and formally extended the invitation and the same was duly accepted. The Executive Committee held five meetings in New York City; these meetings were always attended by some from a distance, and such members as were not personally present invariably reported by letter.

Early in the year Vice-President Philip Breitmeyer of Detroit set the pace for a fine special premium list, seconded by Arthur T. Boddington of New York, which under the fostering care of Messrs. Poehlmann and Asmus and others of Chicago swelled to very satisfactory dimensions.

At the last annual meeting a "Rose Journal" was a topic which grew out of the question given by President Simpson, "How to increase the interest and thus the membership." The Secretary assumed the responsibility of issuing a prospectus and of mailing the same to all present membership; the details of the results will be taken up more fully separately.

The record of the year shows that after nine years the American Rose Society lives—it has crossed the Alleghenies, born in Atlantic City on the ocean shore—holding its earliest exhibit in the Metropolis of America, going to the Garden City of Pennsylvania, then to the scholarly city of Boston, from there to the capital of the nation, welcomed by President Roosevelt, then accepting the cordial invitation from Chicago. Here we are in this Imperial City of the West with such a show before our eyes as maketh the heart glad, and our motto is, "A Rose for every home, a Bush for every garden"; and this, if carried out, means beauty and grace in the homes of all the people.

In the absence of Mr. May, E. G. Hill read the treasurer's report which was as follows:

Treasurer's Report.

The treasurer's report for year ending March 20, 1908, is as follows:

Total cash received on general account	\$1339.62
Total Disbursements	1077.97
To balance on hand.....	\$253.55

In addition to above general account seven new members (life) have joined the Society, making a total of 55 life members to date.

Mr. Hill called attention to the low financial state of the treasury and urged that the society ought to be better cared for by the many men engaged in the rose growing industry which had built more greenhouses and more fine homes than any other one plant. There have been fortunes made

out of roses and it was time something was done to put the society on a good footing. W. A. Manda advocated offering medals and certificates instead of regular cash premiums, calling attention to the fact that these classes were practically ignored at the present show. This was referred to the executive committee. J. A. Valentine then read his paper which was accorded a vote of thanks. W. A. Manda gave an interesting talk on rose gardens, their beauty, their construction and enumerated a few select lists for planting. He spoke enthusiastically of the value of the Rambler varieties for covering rocks and unsightly spots and predicted that this class would soon be extended to include climbing roses that would bloom continuously. After a vote of thanks to Mr. Manda the meeting adjourned until Thursday forenoon.

Thursday Morning Session.

The meeting on Thursday morning opened with a paper by J. F. Sullivan on "The Rose from a Retailer's View and the part that it plays in Decorations, simple and elaborate, of the present day," which was of a high order, vigorous, and a splendid addition to the literature of the Society. An interesting discussion followed wherein Philip Breitmeyer and W. J. Stewart called attention to the merits of the old fashioned Bon Silene and other small roses. W. H. Elliott then read his paper, "What is the proper size of a Greenhouse to grow Roses for Commercial Purposes," which was eminently practical and to the point, in favor of the large type of rose house and elicited many interesting questions, to which he replied. Mr. Maynardier's paper on "Soils" was next listened to.

Buffalo the Next Meeting Place.

The selection of the place for next year's meeting was next in order and Buffalo was the city chosen.

The Election of Officers.

Then followed the election of officers. August Poehlmann, of Morton Grove, Ill., was elected president; W. F. Kasting, of Buffalo, vice-president; Secretary Hammond and Treasurer May were re-elected; Philip Breitmeyer, of Detroit, was added to the Executive Board.

The Exhibition.

The spacious hall in Art Institute was admirably adapted for the rose exhibition which needed only the setting of green furnished by the decorative plants to make it perfection. The exhibits were mainly in the large special classes, the smaller classes being nearly ignored. Richmond, Killarney and American Beauty were displayed in great profusion and superb quality. The color arrangement of the groups was excellent. Among the newer candidates for honors were Mrs. Potter Palmer, Cardinal, Rhea Reid and Wyndmoor, all of which came in for much careful inspection by visitors.

J. F. Ammann was an exhibitor and winner on a number of the regular classes: Poehlmann Bros. won the Dorrance Challenge prize, the E. G. Hill prize for 100 Richmond, their own prize for 100 Pink, the Vaughan cup for 100 Chateaux, the Freeman prize for 100 Mrs. Potter Palmer, the American Florist Special for 50 American

Beauty, the Kroeschell Bros.' prize for 25 Killarney, the Darling prize for 50 American Beauty, the Holton & Hunkel prize for 25 Killarney, and the Bruns prize for 200 lily of the valley. A. Farnewald won the Montgomery cup for 50 blooms of rose of American origin now in commerce, and the Davis Company prize for 50 Liberty. The E. G. Hill Co. won the Manda cup for the largest and most varied collection and the Poehlmann prize for 50 Red, Richmond and American Beauty excluded, with Rhea Reid. W. H. Elliott won the Simpson prize for 100 Killarney, and the Dingee-Conard Co. prize for 50 Killarney. Bassett & Washburn won the Traendley & Schenck prize for 50 Bridesmaid, the Buettner prize for 50 Bride, the Pulverized Manure Co. prize for 100 Bride, the W. W. Barnard Co. prize for 25 Bridesmaid, the A. Dietsch Co. prize for 25 Bride and the Crane Co. cup for 100 American Beauty. Peter Reinberg won the Wilcox prize for 50 Ivory, the Wieter Bros.' prize for 100 Uncle John, the Florists' Review prize for 100 Sunrise, the Keller prize for 25 Richmond and the Newbold prize for 25 Uncle John. George Reinberg won the Poehlmann Bros. Co. prize for 100 Richmond. Myers and Samtman won the Mogg prize for 50 American Beauty, the Deamud cup for 25 Pink not disseminated prior to 1908 with Wyndmoor and the Heller Bros. cup for 50 blooms of rose never before exhibited for competition, with Wyndmoor. Albert Lies won the Bassett & Washburn prizes for 25 Brides and 25 Bridesmaid from growers with less than 50,000 feet of glass. Wieter Bros. won their own prize for 100 Kate Moulton. Robert Scott & Son won the Pierson cup for best new rose not in commerce and never exhibited before this society with Mrs. Jardine. Vaughan's Seed Store won a silver cup and three other prizes in the pot plant classes. The Welch prize for the most artistically arranged vase went to Robert Simpson for vase of Richmond. A certificate of merit was given Myers & Samtman for Wyndmoor. Special mention was given W. A. Manda for Cherokee roses, George Reinberg for display of roses, J. A. Budlong for display of carnations, Bassett & Washburn for new Carnation Orland P. Bassett, and The E. G. Hill Co. for Afterglow. W. H. Elliott received cultural certificate for Killarney.

GARDENERS' AND FLORISTS' CLUB OF BOSTON.

The annual club banquet will be held at Horticultural Hall, Boston, on Wednesday evening, April 1st, at 7 o'clock. Tickets, which are \$1.50 each, may be had from Peter M. Miller, 32 South Market Street, Boston, also from any other club members. No tickets will be sold after March 28. There promises to be a banner attendance at this banquet. The entertainment will be a splendid one and a first-class orchestra has been engaged for dancing.

The club will hold its next field day at the establishment of Thomas Roland, Nahant, on Saturday, April 11, 1908. This will be the club's first visit to Mr. Roland's. Particulars as to car service will be mailed to all members.

William Sim of Cliftondale will lecture on Sweet Peas at the next regular

club meeting on April 21. Other attractive features are being prepared for this meeting.

W. N. CRAIG, Secretary.

SOCIETY OF AMERICAN FLORISTS AND ORNAMENTAL HORTICULTURISTS.

The annual meeting of the Executive Board was held in Niagara Falls, N. Y., at the Prospect House, on Monday and Tuesday, March 23 and 24. Those present were President F. H. Traendley, ex-President W. J. Stewart, Vice-President George W. McClure, Secretary W. N. Rudd and Messrs. Theodore Wirth, J. K. M. L. Farquhar, John Young, E. V. Hallock and George Asmus; also ex-president Wm. Kasting, Prof. J. F. Cowell and ex-Mayor Cutler of Niagara Falls.

NEW HAVEN COUNTY HORTICULTURAL SOCIETY.

A meeting of this society was held on March 17, about sixty members being present. Walter Angus, gardener to Mr. R. Scoville, gave a very interesting and instructive paper on primulas, cinerarias, calceolarias and allied subjects, which was followed by a general discussion. James Bruce, Thos. Nye, A. J. Thompson, W. Bretschneider made very fine exhibits of primulas and cinerarias; John H. Slocombe, a large bunch of perfect double violets. Mr. Angus was accorded a very hearty vote of thanks for his able paper. The meeting was followed by a smoker, which was thoroughly enjoyed by all present.

The society will hold their fall exhibition in Music Hall again this year in November. Quite a number of entries are already in for the amateur gardeners' window-boxes and vases. On April 7 Peter Zuger of Elizabeth Park, Hartford, will read a paper on Bedding Plants.

AMERICAN SOCIETY OF PARK SUPERINTENDENTS.

The executive committee of the American Society of Park Superintendents met at Buffalo, N. Y., on March 21, at the Genessee. President Cowell in the chair. There were also present secretary-treasurer F. L. Mulford, John Chambers and Theodore Wirth. Arrangements were made for the annual meeting of the society at Minneapolis, Minn., on Aug. 11 to 14. Resolutions were adopted commemorative of the late R. H. Warder of Lincoln Park, Chicago.

FLORISTS' HAIL ASSOCIATION.

Hail losses recently reported are, R. S. Murray, Bellefontaine, Ohio; H. D. Schilling, Indianapolis, Ind., and Jos. R. Goldman, Middletown, Ohio. JOHN G. ESLER, Sec'y F. H. A.

CHICAGO FLORISTS' CLUB.

Special notice is given that the next regular meeting will be held Thursday, April 2, at 8 P. M. at the Union restaurant, 111 E. Randolph street.

A CORRECTION.

In the paper by Eber Holmes in last week's issue on page 373, line six the word "moisture" should have been "nicotine."

Obituary

William H. Spooner.

Wm. H. Spooner, for many years a leading horticulturist of Boston, died on Saturday, March 21, in his 75th year, after one week's illness. Up to



WILLIAM H. SPOONER

the time of his final sickness Mr. Spooner was in his usual health and spirits and made his frequent trips to Horticultural Hall, which he was in the custom of making regularly for many years back as a devoted member and faithful officer of the Massachusetts Horticultural Society. At the time of his death Mr. Spooner was the accredited representative of this society in the Massachusetts Board of Agriculture. In former years he had served as a vice-president and trustee of the society and for a term of two years as its president. Some forty years ago Mr. Spooner was associated with the late Francis Parkman in the exploitation of fancy nursery stock and roses. He then became a member of the firm of W. C. Strong & Co., nurserymen and florists, and, about the year 1872, on the dissolution of this firm, he took the Boston store of the concern on his own behalf and conducted same until bought out by W. J. Stewart, who had been in his employ as manager. He then took up the business of hardy rose importing and growing, which he continued for many years at Jamaica Plain, Mass. afterwards disposing of it to J. F. Shea.

Mr. Spooner was a man of kindly, sympathetic disposition, beloved by a large circle of friends in horticultural circles. He served in the Massachusetts legislature for two terms and was a constant advocate and friend of agricultural progress and legislation. A faithful, conscientious man, he will be missed and mourned.

E. J. Castle.

The English trade papers record the death of E. J. Castle on March 4, at the age of 39. Mr. Castle was at one time on the editorial staff of "The

Gardener." He was an able writer, having a thorough knowledge of practical and scientific gardening and allied subjects.

John Moller.

John Moller, an old and valued employe of Siebrecht & Son, New York, while trimming a tree fell to the ground. He was carried to the St. Vincent Hospital, where he died on March 13.

C. T. C. Deake.

Cyrus Towner Curtice Deake died on March 11 at his home in Asheville, N. C. He was the founder of the Idlewild Floral Co. Mr. Deake was 84 years of age, and is survived by his wife.

James P. H. Ruth.

James P. H. Ruth, who had greenhouses at Wyomissing, Pa., died at his home in Brookside on March 16, aged 41. A widow and daughter survive him.

E. D. Darlington.

E. D. Darlington, superintendent at the Fordbrook seed farms of W. Atlee Burpee & Co., at Doylestown, Pa., died on the morning of March 26.

Joseph Kaiser.

Joseph Kaiser, a florist of Belleville, Mo., died suddenly on March 14 in his fifty-ninth year.

Alfred Hildred.

Alfred Hildred, a prominent retail florist of Chicago, passed away on March 17.

J. M. Gasser.

This well-known and highly respected florist of Cleveland, Ohio, died at Flint, Mich., on March 12, of heart failure, after a period of ill-health extending over two years. Mr. Gasser



J. M. GASSER

was born in Switzerland in 1841 and came to Cleveland when a youth. He served in the Civil War and was wounded. After the close of the war he was employed in the post office, and afterwards conducted a small ice cream business in Cleveland and

taught dancing, and at the same time began a modest trade in selling flowers, getting his supply from Boston, New York and Philadelphia. Close industry on the part of Mr. and Mrs. Gasser resulted in a rapidly developing business, which finally grew into the leading florist establishment of the city, with extensive greenhouse ranges as a source of supply. In his active business days Mr. Gasser, although working hard and incessantly, was never too tired or too busy to extend a generous welcome to a visiting brother florist. He was an earnest supporter of the S. A. F. and a regular attendant at its conventions, and when the society met in Cleveland thirteen years ago he entertained the visitors in lavish manner. He leaves a wife and one married daughter.

The business will be carried on with no change in policy or plans at present.

NATIONAL HORTICULTURAL SOCIETY OF FRANCE.

The magnificent autumn shows of this society, which are held every year in Paris, are a source of delight to every admirer of the chrysanthemum, and there are many features of interest to be seen there that are wanting in our English shows. Just now, when the chrysanthemum fever is very strong among the French growers, there is a keen desire to keep up the interest in every possible way. It is now announced that the next Paris chrysanthemum show will be the twenty-fifth in succession, and that a portion of it will be devoted to exhibits of an artistic and literary interest. The final arrangements are not yet made, but a preliminary notice has been given that there will be a special department reserved for those who can exhibit books, publications, prints, engravings, pictures and old catalogues relating to the chrysanthemum. Another part of the show will be reserved for blooms of old varieties that were in cultivation prior to the year 1896.

C. HARMAN PAYNE.

NATIONAL CHRYSANTHEMUM SOCIETY OF ENGLAND.

At the recent annual meeting of this society the following appointments of officers were made: President, Sir Albert Rollitt; chairman of committee, T. Bevan; vice-chairman, E. F. Hawes; treasurer, John Green; foreign secretary, C. Harman Payne; general secretary, P. A. Witby. The late president, C. E. Shea, has been obliged to retire on account of ill health. A practical grower for show and a seedling raiser of some repute a few years ago, Mr. Shea's services have been recognized by the society by placing his name on the list of vice-presidents. For lack of funds the society is unable to continue the publication of the year book started last year. It will be observed that Mr. C. Harman Payne has been again elected foreign secretary, a position he has occupied for 20 years in succession.

SOME NEW THINGS IN AN OLD
COUNTRY, OR ONE MONTH'S
OBSERVATION BY LAND
AND SEA.

Read before the Philadelphia Florists' Club, March 3, 1908, by J. Otto Thlow.

To give a recital of current events and the routine of everyday life with its special happenings in parts of Europe would be only a repetition of what you often read or have known; and that which is historic or prehistoric we can glean from the unending list of novels and magazine sketches contributed from time to time by those who have visited Europe and have studied the quaint and ever-interesting points and general conditions, and through their enthusiasm, which is usually incited after a first visit, some very interesting descriptions are given. These might be termed pilots for those who contemplate a trip abroad, and a fair guide to points of interest.

The average American maps out the territory he wishes to cover, and in this particular his judgment is rarely commensurate with his desires, and upon his return he can always find one who has been over the same ground who can tell of entirely different scenes and incidents which have been overlooked. It all depends upon with what enthusiasm and zeal one starts out on a sight-seeing trip for enjoyment, recreation and knowledge. We are assured of one fact, however, that traveling broadens the mind, ripens experience and adds to life's category interesting events, and we thereby learn in part how the other half of the world is living.

It is true that even the ordinary conditions as they confront the average American when traveling in Europe are to him new; in particular the ancient landmarks and objects of interest, and every wonder of which history, ancient and modern, is elaborate in its description. Customs, conditions and the general routine of everyday life in Europe, so vastly different to American methods, make a lasting impression.

Horticulture Abroad.

To the horticulturist there is much of interest, especially so when it appears that the conditions seem to be so favorable for the development of plants, some of which we try to bring under subjection to our varying conditions, to which they unwillingly yield. The methods of cultivation followed in the production of plants are the same methods which have been applied for many years, or even decades, with but few variations. We have either not yet learned how to do it, or the system coupled with the conditions will remain where it is. This much, however, can be said of our European brother horticulturist: his training is much more thorough, his early association with plant life, which in some degree is tutored in his home, stirs a more intense love for the art and an untiring interest for the vocation. Men and women in the homes of city and country regard the most humble domicile incomplete for themselves and families without plants, flowers or shrubbery under their own personal care. This inborn love for the adornment of the home has been handed

down to posterity, so that it has become a part of the nature of children to busy themselves with the care of plants. A much greater impetus to the advancement of horticulture is given by the personal interest of the nobility and the people of means in that they are surrounded with the best taste in the horticultural art, and perpetuate the estates of their ancestors with even more elaborate outlay and show, and do much by personal contribution to perpetuate the interest among those who are engaged in the pursuit of horticulture as a business.

It was my good fortune to have the privilege of making an interesting journey across the ocean with one who knew just how to "do" Europe, and we did it as best we could in the short space of four weeks. Therefore, there is much of interest yet to be told from a more extended tour than could be gleaned from so short a stay in the places of interest as this sketch will afford. Having had the honor of being the traveling companion of Mr. Jacob D. Eisele, who is not only known to the most of our trade fellows here, but also to the horticultural craft of Europe, our reception was with a pomp and courtesy in which I undeservedly participated, and which permitted me to penetrate some of the so-called Meccas of Horticulture. Just what we saw and did would be so little interesting to you, yet to tell how we did some things might be wholesome to all interested.

Ocean Comforts.

The newest thing belonging to an old country was the magnificent ocean palace, the "Kronprinzessin Cecile," the North German Lloyd's crowning effort of ocean comfort. This ship we boarded September 17, leaving Hoboken at 11 o'clock that day for what we hoped to be a delightful trip across the Atlantic. At no time during this short journey of six days was there a moment unprofitably spent, and having become accustomed for many years to a simple mode of living, so far as food was concerned, it was quite natural for the digestive organs to resent such great surprises as one is enticed to indulge in, especially when you must pass in the attitude of a cake walk before seated observers on deck. Everything of an entertaining nature is afforded a tourist to employ the time, not excepting the comforts of the extensive and cozy smoking room.

On Monday, September 23, at 10 A. M., we were unloaded on the tender at Plymouth, England, remaining long enough to have our cigars inspected and reduced, then entered the train on the London and Southwestern Railway for London, passing through Devon, Somerset, Surrey and Middlesex, then reaching the world-famous, and England's historic city, London, where the concourse of the masses through the ages have learned by discipline and practice to pass and repass on foot or by vehicle without friction.

In London.

As much as a part afternoon and evening would afford was profitably indulged in; an evening ride on a bus seated near the front, and close to the driver, who, for a slight recognition, was willing to point out and call out the noted places, and if the

trip did not include some of the distant places of interest, they were numbered among those of the passing thoroughfare. After retiring and a few hours of sleep it was quite in place for a stranger to be aroused to witness a London fire in the neighborhood of the hotel. A few moments watching and anxiety as to our safety assured us that the firemen were better able to cope with the conditions, and the hazard seemed to be lessening, so we were constrained to retire again for the balance of sleep due us.

Fortune seemed to lurk about us, and for the full enjoyment of the following day we had the best of weather, and at no time during our stay in this great city did we encounter the well-known and dreaded fog. A trip to the outskirts and among some of the well known horticultural establishments filled the two days with pleasant experience, and very pleasant recollections: enjoying while riding through the country the homes of the cottagers and their surroundings; many little homes in bowers of vines and bloom, and every inch of the enclosure rich in bright flora.

Kew and Covent Garden.

Having already determined upon a visit to the pride of England's horticultural school—Kew Garden, our desire was intensified by what had already been enjoyed. Starting from Charing Cross Sub, we were soon at Kew Gardens, which well deserves the name of a perfect Eden in good order. The botanical department is of more than ordinary interest in that it is attractive and under a splendid system and care. Many beds were planted with such stock as we could never venture a trial, and were there in full glory. The roses and dahlias were clothed with a wealth of bloom, and a promise of more. The arrangements for studying trees and shrubs; in fact, all plants, were minutely confined to proper labeling, which even to the novice is an incentive that there is need of system and classification in horticulture.

Many other places of great and noted interest were to be seen, but our stay permitted only a few; viz.: the noted St. Paul's and Westminster Abbey. An early start was made the next morning for the renowned Covent Garden to watch and study the trend of commerce in plants and flowers. Much is done in a very short time and at an early hour. At this time, September 26, cut chrysanthemums are in abundance, with the almost glut of roses cut from field-grown plants, and hardy asters (Michaelmas Daisies) in masses of color. The fruit and vegetable markets were equally active, and afforded much interest. We returned to the hotel in time for breakfast, and then to train for Dover, embarking there on a modern turbine steamer for Ostend, Belgium. Conditions were certainly of the best—lunch uninterrupted, and the balance of time on deck.

In Belgium.

Ostend (Belgium's Atlantic City, or Newport) was reached in early afternoon, and after the customs department officers had made their usual examinations, we were under way for Ghent, arriving there in good time to see part of this historic city—among quaint conditions and interesting peo-

ple. The cities of Ghent and Bruges are highly interesting in horticulture—the home of the azalea and bay, the fields of tuberous begonias, and glass areas of palms. Prominently in all thoroughfares is seen the ever faithful and unpaid laborer, the dog, hitched beneath the hand carts, tugging and helping the load onward; the wooden shoe in evidence on the children in the city, and the laborers in the fields. Ghent is an active city of 160,000 inhabitants, with many places of historic interest. Bruges, one hour's train ride east, is also very interesting and very quaint. The impression left by this short sojourn, the kind attention and courtesy of our Belgian friends, are not to be forgotten.

Sunday morning, September 29, we went by early train to Brussels, where a full day of sight-seeing was afforded, visiting its Galleries, Palace of Justice and Park, the latter being particularly interesting, as it bears the mark of nature's freedom. The Sunday morning market in the Court, surrounded by many ancient and historic structures, is very interesting, combining peculiar subjects; viz.: flowers, birds, pigeons and dogs. The mass of humanity which gathers here during the morning hours are through with their bartering by noon, the Court becomes deserted, and then the promenade streets and avenues are active and brilliant with gay attire of people on foot and in vehicles. One day in Brussels systematically conducted will afford a very fair idea of its proportion, its life and condition.

In Germany.

The next point of interest was Cologne, Germany, which was reached by 11 P. M., after a ride of six hours. As time was short in this city, we were fortunately domiciled near the famous Dome, and at 6 A. M. on the morning of September 30 another glimpse of the wonderful structure conveyed a favorable impression of this masterpiece of architectural art and genius. At 6.15 A. M. we were on the deck of the Rhine boat, "Elsa," prepared for a day of sight-seeing along this noted stream, which has been the ambition of millions of Americans, and seen by as many. The trip is one of unending interest, and rarely satisfies the observer with one glimpse of its grandeur and constant change of panorama, but from only its partial impression it leaves a determination to see it again.

(To be Continued.)

Roses and How to Grow Them. By many experts. Price, \$1.10. Order now from HORTICULTURE Publishing Co.



are money makers and money savers because they enable you to do the work right, with little labor and without wasting solution. We make an outfit for every need, from large Power Sprayers to small Hand Sprayers—each the best of its kind. Special Sprayer Book Free, illustrating and describing our complete line. Investigation pays. (Chas. J. Jager Co., 21-23 Franklin St., Boston, Mass. Branch: 33 Canal St., Providence, R. I.)

HARDY NURSERY STOCK

ORNAMENTAL and FRUIT TREES

Shrubs, Roses, Vines and Small Fruits

We make a specialty of supplying Florists' Trade, growing a complete line of everything that is hardy in the Northwest. Plants put up separately or in bulk, as they may desire. Full Line of Hardy Perennials. If you have not received our Wholesale Price List, write for it at once, or send list for Special Prices.

L. L. MAY & CO.,

ST. PAUL, MINN.

Biota Aurea Nana

AND A LARGE STOCK OF

Conifers, Rubbers, Camellias, Magnolias, Broad-Leaved and Deciduous Shrubs, Shade Trees, Field-grown Roses, Palms, and a general line of Nursery Stock for the Trade.

Send for Trade List

P. J. BERCKMANS CO., Inc., **FRUITLAND NURSERIES**

Established 1836.

AUGUSTA, CA.

PREPARE FOR EASTER

And buy your plants from the old reliable Wholesale Grower of Easter Plants, Godfrey Aschmann, Philadelphia.

Easter Lilies, *Lilium multiflorum*, height, 15 to 40 inches, 6-in. pot plants above five buds, 10c. per bud; plants under five buds, 12c. per bud.

Azalea Indica. Of this fine Easter plant we have an immense stock. Mme. Van der Cruyssen (best double pink), Niobe (double white), Deutsche Perle (double white), Simon Mardner (double pink), Apollo (red), Vervaeuena (double rose variegated), Empress of India (double variegated), Prof. Wolters; Schryveriana (dark rose), Bernard Andrea alba, double white, of this variety only large plants, 1.00, 1.25, 1.50, 2.00 each; and many other sorts, price, 60c. 75c. 1.00, 1.25, 1.50 to 2.00 each.

Spiraea Gladstone, large plants only, full of buds and flowers, 6-in., 50c. 7-in., 75c. to 1.00 each.

Hydrangea Otaksa (pink), 6-7-in., 50c. 75c. 1.00 each.

Primula obconica, 5 1/2-in., 2.00, 2.50, 3.00 per doz.

Cineraria Hyb. best strain **Grandiflora**, 5, 5 1/2, 6-in. pots, 2.50, 3.00, 4.00, 5.00 per doz.

Hyacinths, dark blue, light blue, pink and white, 12.00 per 100.

Touneol Tulips, best double Tulips, 3 bulbs in one pot, 1.50 per doz. pots.

Von Sion Daffodils, Best Yellow Double Narcissus, 5, 5 1/2, 6-in. pots, 3 bulbs in one pot, 2.00, 2.50, 3.00 per dozen pots.

Begonia new improved Erfordi, 4-in., 20c, 5 1/2-in. 25c.

Begonia Flambeau, good seller, 5 1/2-in. 25c, 4-in. 20c.

White Daisies, 5 1/2-in. 25c.

Kentia Belmoreana and Forsteriana, 4-in. 35c, 5 1/2 to 6-in., 50c, 60c, 75c.

Lantana Borbonica, 5 1/2-in. 35c.

Ficus Elastica or Rubber Plants, 5 1/2 to 6-in. pots, 40c, 50c.

Ipomoea Multiflora, best pure white Moon Vine, 2 1/2-in. pots, \$5.00 per 100.

Araucaria excelsa glauca, Specimen Plants, 6 and 7-in. pots, 6 yrs. old, 4-5 tiers, 25-40 inches high, 1.75, 2.00, 2.50, 3.00. Robusta compacta, 7-in., large plants, 30-40 inches, 2.50, 3.00. Excelsa, 4 yrs. old, 6-in. pots, 4-5-6 tiers, 20-30 inches high, 75c, 1.00, 1.25 each; 5 1/2-in. 50c.

Please mention if plants are to be shipped in or out of pots. Cash with order please. All goods must travel at purchaser's risk. No lilies sold by themselves, other plants must accompany the order.

GODFREY ASCHMANN,

1012 West Ontario St., Philadelphia, Pa.

Importer, Wholesale Grower and Shipper of Pot Plants

The S. A. Nutt geraniums advertised in your Buyer's Directory went fine. Did not have enough to supply the demand. C. W. Moeckel, 17 Summer St., Fitchburg, Mass.

ROSES

100 of the best Hardy sorts.

HYBRID PERPETUALS

Finest English Grown Plants

Dozen, \$3.50: 100 \$25.00

EVERBLOOMING

HYBRID TEAS

Bloom from Midsummer until frost.

Dozen \$5.00: 100, \$35.00

Hardy Climbing Roses

All the leading sorts.

Catalogue Free on Application.

R. & J. FARQUHAR & CO.

6 and 7 So. Market Street,

Boston, Mass.

A NEW STRAWBERRY

We have been growing and selling Strawberry Plants in this town over THIRTY YEARS. We introduced Brandywine, Kittle Rice, Sen. Dunlap, Wm. Belt and others of value. Now we are bringing out

THE HIGHLAND

which we expect to take the lead as a Money-Maker. Let us tell you about it and forty others. It will cost you but a postal card.

M. CRAWFORD & CO., Box 1020, Cuyahoga Falls, Ohio

VINCA Var. and Major FINE STOCK

Field-grown stock, potted into 4-inch and grown on. Ready for 5-inch now. 1st size, \$7.00; 2d, \$6.00 per 100. No cuttings offered. Packed light. Cash with order.

J. J. ARNOLD, Homer, N.Y.

This narrative is the experience of many men and it is true.

Hammond's Grape Dust

For Mildew on Roses, Carnations, Etc., in use since 1884

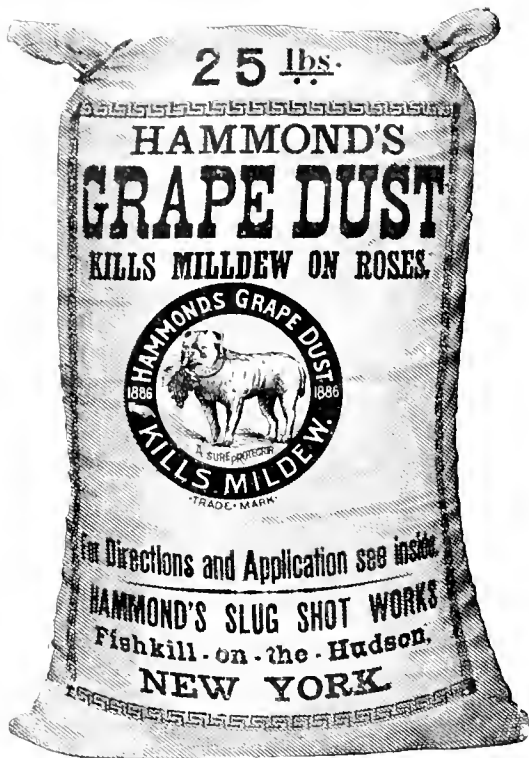

Clifton, N. J., Oct. 11, 1907.

Dear Mr. Hammond:

In reply to your inquiry regarding my experience with Grape Dust, would say that I am glad to be able to say a good word for the article in question, because I have found it so generally satisfactory when used for mildew on roses.

I do not know anything about its constituents, nor do I care so long as it does the work, and is as economical as anything else on the market.

During the summer when the steam pipes cannot be brought into use to check mildew, and dusting over the foliage has to be resorted to, we prefer to use Grape Dust rather than sulphur, because it is so much lighter and finer in texture; a given number of pounds will cover more than twice the number of plants, will cover them more thoroughly, and Grape Dust can be put on with a bellows in about one-fourth the time that would be required for sulphur.

The fact that I have used it continuously for ten or twelve years should prove to you that I consider it the best article on the market for the purpose for which it is used.

With best wishes I am, Yours very truly, ROBERT SIMPSON.

Put up in 5 and 10 lb. packages at 7 cents per lb.; also in 25 lb. bags, 100 lb. kegs and in barrels of 200 lbs., net. Kept in stock and sold by the leading Seedsmen in America.

USE "SLUG SHOT" FOR SOW BUGS, ETC.

Hammond's Paint and Slug Shot Works
FISHKILL-ON-THE-HUDSON, N. Y.

Tobacco Paper
IS THE
**STRONGEST,
BEST PACKED,
EASIEST APPLIED.**

"NICO-FUME"

LIQUID
OVER 40% NICOTINE

By far the
CHEAPEST.

Furnishes the
Most Nicotine for the Money!

JUST NOTE PRICES!

Pint.....\$ 1.50
½ Gallon..... 5.50
Gallon..... 10.50
5 Gallons..... 47.25

... Manufactured by ...

THE KENTUCKY TOBACCO PRODUCT CO., Louisville, Ky.

PLANT IMPORTS.

There were entered at the port of New York during the week of March 18th to March 24th, inclusive, the following goods:

Via Antwerp: J. Ter Kuile, 2 cs. plants; Vaughan's Seed Store, 1 cs. do.

From Rotterdam: H. M. Baker, 53 cs. plants, 21 cs. bulbs; H. F. Darrow, 31 pgs. plants, 2 pgs. seed, 2 bags bulbs; W. Elliott & Sons, 36 cs. plants; J. W. Hampton, Jr. & Co., 2 cs. do; R. F. Lang & Co., 17 cs. do; McHutchison & Co., 98 cs. do; Maltus & Ware, 216 cs. do; 15 pgs. do; 56 cs. trees and shrubs, 3 cs. flower roots, 13 cs. trees and shrubs; P. Onwerkerk, 75 cs. trees; C. B. Richard Co., 55 cs. plants, 16 pgs. do; Stump & Walter Co., 8 cs. do; J. M. Thorburn & Co., 4 cs. do; Ammermann & Patterson, 10 cs. do; Sundry Forwarders, 21 cs. do; 3 cs. trees, 1 cs. bulbs.

From Germany: C. C. Abel & Co., 3 cs. plants; J. M. Thorburn & Co., 1 bg. seeds; Forwarder, 1 cs. trees.

Via Southampton: F. Berry, 5 cs. plants; McHutchison & Co., 31 cs. do; Maltus & Ware, 16 cs. do; August Rolker & Sons, 19 pgs. do, and trees; J. M. Thorburn & Co., 2 bgs. flower seed; Vaughan's Seed Store, 8 cs.

plants; Sundry Forwarders, 10 cs. do; 1 cs. trees, 33 bgs. garden seed.

From Glasgow: J. M. Thorburn & Co., 15 bgs. grass seed.

Via Havre: H. F. Darrow, 42 pgs. plants; Maltus & Ware, 4 pgs. do; August Rolker & Sons, 1 cs. nursery stock; Sundry Forwarders, 321 pgs. plants, 11 cs. do.

You will find something worth reading on every page of HORTICULTURE.



Cattle Manure In Bags

Shredded or Pulverized

Best and safest manure for florists and greenhouse use, absolutely pure, no waste, no danger. Write for circulars and prices.

The Pulverized Manure Co., 31 Union Stock Yards, Chicago

SQUABS

Every man should have at least 10 to 20 pair of the celebrated Plymouth Rock Homer Pigeons or their own Squab raising. It pays and is a pleasure besides. Write the undersigned for prices on mated birds.

THE BEST IN THE WORLD
Jno. A. Kepner, Box 3, Harrisburg, Pa.

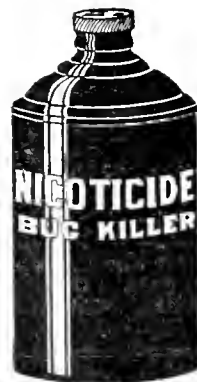

The Best Bug Killer and Bloom Saver

For PROOF Write to

P. R. Paethorpe Co. OWENSBORO, KY.



DREYER'S Florist Specialties. PEERLESS PLANT FOOD "Odorless."

The best and clear est fertilizer for house plants.
Half pound, \$1.00 doz.; \$5.00 per 100.
One pound, \$1.50 doz.; \$12.00 per 100.

Retail price, 15c. ar. doz.
HENRY A. DREYER, 714 Chestnut St., PHILADELPHIA, PA.

300,000 CALIFORNIA PRIVET

1-year-old, 18-24 inches, 2-4 branches.....	Per 1000	\$ 15.00
\$145.00 per 10,000; \$645.00 per 50,000		
2-year-old, 2-3 ft., 5, 8 and 10 branches.....	35.00	
Per 100		
6-year old, standard, 5-6-ft., heads 2-2½-4½-ft. diameter.....	75.00	
6-year-old, standard, 4-5 ft., heads 2-2½-ft. diam.	50.00	
2-year-old, standard, 4-5 ft., heads 18-24 in. diam.	40.00	
6-year-old, pyramidal, well sheared, 4-5-ft. high, 3-4-ft. diameter.....	75.00	
6-year-old, 3-4 ft. high, pyramidal, 2½-3 ft. diam.	50.00	
2-year-old, 2½-3 ft. high, pyramidal, 18-24-in. diameter.....	40.00	
Elms, Am., fine trees, 12-12 ft. high, 1½-2 in. cal.....	40.00	
Elms, Am., fine trees, 9-11 ft. high, 1½-1½ in. cal.....	\$25.00 per 1000	30.00
European Linden, 12-15 ft. high, 2-3 in. cal.....	60.00	
Althaea, double white with maroon center, 5-6 ft. high.....	15.00	
Althaea, double whit. with maroon center, 4-5 ft. high.....	12.00	
Althaea, double white with maroon center, 3-4 ft. high.....	10.00	
Spiraea Billardii, 4-ft high.....	6.00	
Forsythia Viridissima, 3-4 ft. high.....	10.00	
Lilac Rubra, Dr. Marley, 3-4 ft. high.....	10.00	
Deutzia Crenata, 4-5 ft. high.....	11.00	
Deutzia Gracilis, 4-year-old plants.....	8.00	
Yucca Filamentosa, blooming plants.....	35.00	

I will have a large collection of bedding plants for Spring delivery out of 25 greenhouses, such as Roses, Geraniums, Coleus, Heliotrope, Salvia Bomire, or Scarlet Sage (which is the best bedding plant today), Lantanas, Verbenas, Begonias, Vinca Rosea, Alternantheras, red, yellow and pink; all kinds vase and hanging basket plants.

Send me your wants and I will give you price.

Carlman Ribsam

Office, 31 Wall St., TRENTON, N. J.
Greenhouses, East State St.
Nursery, Hamilton Ave.

Hardy Roses

American Grown—Superior to Imported

We have unsold at the present time the following varieties—all field grown plants, grown in our nurseries at Rochester, N. Y.:

Anne de Diesbach	Princess Camille
Clio	Lilch Brunner
Fran Karl Druschki	Crimson Rambler
General Jacqueminot	White Rambler
John Hopper	Yellow Rambler
Mme. G. Lutzet	Philadelphia Rambler
Marshall P. Wilder	Common Sweet Briar
Mrs. John Laing	Mme. G. Brault
Paul Neyron	Wichuriana (The Type)

These plants are in our storage cellars and can be shipped at any time. Prices on request.

ELLWANGER & BARRY

Nurserymen—Horticulturists
Mount Hope Nurseries, Rochester, N. Y.

AMERICAN NURSERY CO., COMBIN- ING

FRED'K W. KELSEY, New York City
F. & F. NURSERIES, Springfield, N. J.
BLOODGOOD NURSERIES, Flushing, L. I.
N. J. & L. I. NURSERIES

We can supply your every need. Write for prices
Sales Department
150 BROADWAY, - NEW YORK

In ordering goods please add "I saw it in HORTICULTURE."

Hardy Rhododendrons, Azaleas Conifers, Clematis, H. P. Roses, Shrubs and Herbaceous Plants from our
HOLLAND NURSERIES

Prices Moderate

P. OUWERKERK, 246 Jane St., Weebawken Heights
P. O. No. 1, Hoboken, N. J.

BARGAINS in TREES and PLANTS

Six for 25c., delivered free by mail
List Free. D. J. TWOMEY, Dept. H., Geneva, N. Y.

TAUSENDSCHON

or in English **Thousand Beauties**, is the sensational new Climbing Rose of the year. Every florist should have it. It is not excelled for forcing purposes and for general planting by any Climbing Rose now known, **not even baring Crimson Rambler**. This is the coming forcing Rose. Get your stock early. Illustrated in ten colors and gold in our Catalogue for 1908, the **Leading Rose Catalogue of America**. Every Rose worth having is described in it. Copy free for the asking.

Strong plants of Tausendschon from 3-inch pots,
10 for \$1.50; \$12.00 per 100; \$100.00 per 1000.

THE DINGEE & CONARD CO., WEST GROVE, PA.

JOHN WATERER & SON, Ltd. American Nursery, Bagshot, England

Are Specialists in the

REALLY HARDY VARIETIES
of Rhododendron Hybrids and in Select Varieties of Hardy Border Plants.

HARDY NORTHERN GROWN NURSERY STOCK

At Reasonable Prices

FRUIT AND ORNAMENTAL TREES, SHRUBS, VINES, ROSES AND
HERBACEOUS PERENNIALS IN GREAT VARIETY

Catalogue and Price List for the asking

BAY STATE NURSERIES, NORTH ABINGTON, MASS.

NEW — NEW RAMBLER ROSE "NEWPORT FAIRY"

To be disseminated Spring, 1908. Ask for illustrated pamphlet and prices

JULIUS ROEHRS CO., Rutherford, N. J.

SPECIMEN EVERGREENS

Box Plants, Azaleas, Rhododendrons, Roses, Herbaceous Perennials

In fact everything in hardy stock for Garden, Lawn and Landscape Planting.
General Catalogue and Trade Lists on application.

The NEW ENGLAND NURSERIES, Inc., Bedford, Mass.

LIVE FENCES

We believe we are the largest growers of Hedge plants in America—Privet our specialty—can supply any quantity both

Amoor River and California, strong plants, at \$25.00 per M. Other varieties. Prices on application.

PETER'S NURSERY COMPANY, - Knoxville, Tenn.

The MORRIS NURSERY CO.

West Chester, PA.

NURSERIES ESTABLISHED 1849

SPECIALTIES for SPRING 1908

Norway Maple, 2-2½ in. dia. and 2½-3 in. dia.
Carolina Poplars, 2-2½ in. dia.
Cal. Privet Hedge Plants, 2 yrs. old 2-3 ft. and 3 and 4 yrs. old 3-5 ft. Dwarf Box, 3-6 in.
Rhododendron Hybrids, 18-24 in. and 2-3 ft. choice hardy varieties. Rhododendron Maximum, 2-8 ft., fine plants in car lots.
Kalmia Latifolia 1-4 ft., fine plants in car lots.
Blue Spruce, Koster's, 3-5 ft.
Hybrid Roses, choice varieties.

Catalogue mailed upon request. Address all communications to

The MORRIS NURSERY CO

Sales office, 1 MADISON AVE., NEW YORK

GRAFTED STOCK

**BRIDE, BRIDESMAID
and RICHMOND**

Write For Prices

MONTROSE GREENHOUSES

MONTROSE, MASS.

Seed Trade

Counter trade is active throughout the Southern Central and Western States and is looking up in New England, but no where is it as active as last year at this time. Counter trade is so dependent on the weather that March this year could scarcely be expected to equal such a warm spring-like month as March of a year ago. Mail order houses are now the busiest they have been for several years, and if there is no decline in the volume of business for the next thirty days, they will have had one of the best years in the history of the trade, if it ends right there, but it will not, of course, though it will be nearing the vanishing line after April 20.

The danger of stretching one's capital over too great a volume of business has been very clearly brought home to many who have been rash enough to do this. So far as known, few seedsmen can be included in this list, be it said to the credit of the seed trade, but some other industries with which the seedsmen are in close business touch have not been so wise or prudent, and several firms are some distance removed from Easy street in the matter of financial resources. A forcible reminder of all this was the passing of the Erie Preserving Co., of Buffalo, N. Y., into the hands of receivers some ten days or two weeks ago. This is one of the old firms in this line of business, having a large trade in all parts of the country, and turning out annually from its several plants, not far from 1,000,000 cases of goods. It is believed that the firm's embarrassments are only temporary and that they will operate as usual the coming season.

There are two or three other prominent concerns in this same line of business who are sailing uncomfortably close to the shoals, and it behooves seedsmen to be very careful to whom they extend credit, and particularly in large amounts. This warning may possibly save many vain regrets.

F. B. Mills, of Rose Hill, N. Y., who for the past two or three years has been conducting a large part of his business from Syracuse, N. Y., and who this season opened a branch at Washington, Iowa, is said to be doing a very heavy business. He directs everything from his perch on the crest of "Rose Hill," and seldom takes the trouble to confirm or deny any rumor about himself or his business. He is one of those reticent men from whom information is drawn only with a corkscrew. But after all, success is usually the measure of a man's ability, methods so long as they are legitimate being a minor consideration.

The selection of the Pouchatrain as the headquarters of the American Seed Trade Association at the annual convention at Detroit, June next, does not seem to have met with unqualified approval. This house is all that can be desired, excepting in the matter of price. It is strictly European, single rooms costing from \$2.00 per day up. Even if no advance in rates is charged,

it will cost from \$4 to \$5 per day to live at this hotel, while the Cadillac, which is a high-class hotel, charges \$3.50 per day including meals for one in a room, or \$3.00 each per day with two in a room. It is understood that the Cadillac would have been selected, but from the fact that it was booked up for another convention the same week as the seedsmen's. But could not the seedsmen have postponed their convention a week?

There is no desire to find fault with the gentlemen having this matter in charge, and perhaps their reasons when clearly understood, fully justify their action, but the writer is only stating what seems to be the sentiments of a considerable number of seedsmen. However, let us hope everything will end in complete satisfaction to all.

Most of the pea and bean growers report their acreage for the coming season as fully booked, and in fact unless there is a very full crop, short deliveries of the wrinkled varieties of peas will be the general order of the day. There is little doubt that a 75 per cent. delivery will be more acceptable to canners especially, than 100 per cent. Even to the seedsmen, a 75 per cent. delivery means more profit than full delivery, as full delivery usually means a surplus in the growers' hands with which the dealer must reckon in making prices, and generally it means a surplus to be carried over at the end of the season.

Not much activity at present in wholesale lines excepting in the matter of fill in orders, but the retailers are having their innings, and may they wax fat and prosperous.

The California Seed Growers' Company has purchased a portion and rented the remainder of the Furlong ranch near Gilroy, Calif. H. M. Wolfe is president, and it is stated that Ah Him, who has had charge of the field department of C. C. Morse & Co., will be manager.

The L. L. Olds Co., of Clinton, Wis., have opened temporary quarters in the Isham building.

CATALOGUES RECEIVED.

C. Van Tol, Katwijk, Holland.—Illustrated Descriptive Catalogue of Bulbs and Roots.

Thaddeus N. Yates Co., Philadelphia, Pa.—Trade List of Trees, Shrubs, Vines, etc., for spring, 1908.

Schaum & Van Till, Hansa Nurser-

ies, Boskoop, Holland.—Wholesale Trade List of Nursery Stock.

T. C. Thurlow & Co., Cherry Hill Nurseries, West Newbury, Mass.—Select list of Peonies, Iris and Phlox; also wholesale nursery catalogue.

Iowa Seed Co., Des Moines, Ia.—Emergency edition and condensed seed catalogue. Issued because the regular edition issued last December has been exhausted.

F. E. Conine Nursery Co., Stratford, Conn.—Catalogue of nursery stock, spring and fall, 1908. A well gotten up list, freely illustrated. This company is rapidly forging ahead.

S. G. Harris, Rosedale Nurseries, Tarrytown, N. Y.—Descriptive Catalogue, with supplement for 1908. A. McFarland production, consequently typographically perfect.

Bay State Nurseries, No. Abington, Mass.—Special Price-List for Gardeners and Owners of Estates only. Trees, vines, roses, herbaceous perennials, etc., are listed in full variety.

W. W. Hunt & Co., Blue Hills Nurseries, Hartford, Conn.—Catalogue of fruit and ornamental trees, hardy plants, dahlias, etc. A very full list, bearing the lineaments of prosperity.

American Nursery Company, 150 Broadway, New York.—A very handsome illustrated catalogue, on the same order as the well-known previous publications by Fred. W. Kelsey. Also wholesale price list for spring, 1908. Bloodgood Nurseries, F. & F. Nurseries and N. J. & L. I. Nurseries are now represented in this company.

MUSHROOM SPAWN

Michell's English Brand

Used by the leading growers on account of its superior quality. SPECIAL PRICE FOR THIS WEEK ONLY: 12 bricks \$1.40; 100 lbs. \$5; 1000 lbs. \$47.50.

A POINTER → → → Spawn inserted under the sod in lawns and pastures in spring will give a good crop after the fall rains—at almost no expense.

Send for our culture circular. Also Spring Wholesale Catalogue of seeds, etc.

HENRY F. MICHELL COMPANY
1016 Market Street, Philadelphia, Pa.



Horticultural Products
W. ELLIOTT & SONS, 201 FULTON ST. NEW YORK

What is the best Aster Seed to plant?

Why the very best seed to sow
Varieties that all should grow
Kinds that bring to you no woe
Bear the trade mark "ALTIMO."

Send to-day for Aster Book and Competition Card for the \$250 Prize Aster Growing Contest, Both Free.

ALTIMO CULTURE CO., = CANFIELD, OHIO

TRIP TO THE GHENT QUINQUENNIAL.

The British horticultural traders' annual tour this year will be made to Holland and Belgium on account of the Ghent Quinquennial, and the itinerary as published by the Horticultural Trade Journal is as follows: April 21, leave London; 22d-23d, in bulb district of Holland; 24th, nurseries of Ghent and Loochristii; 25th-26th, Ghent; 27th, those booked for seven days return to London; the ten days' party start for Brussels, where they remain until the 30th, when they go to Bruges and start for London. Arrangements are made for entertainment by the Dutch bulb growers. This is an excellent opportunity for those who wish to make this trip without worry about conveyances or foreign language.

Vegetable and Flower **SEEDS**
 Reliable and Tested. Catalogue Mailed Free
WEEBER & DON
 Seed Merchants 114 CHAMBERS STREET NEW YORK

JUST ARRIVED
LARGE SHIPMENT OF
High-Grade SCOTCH SOOT.

We have the Stott Double Nozzle
THOMAS J. GREY CO.
32 & 33 So. Market St., BOSTON

BRIDGEMAN'S SEED WAREHOUSE
RICKARDS BROS.
Props.

37 East 19th St., - NEW YORK CITY

BRASLAN SEED GROWERS CO.
GROWERS FOR THE
WHOLESALE TRADE ONLY
SAN JOSE, - - CALIFORNIA

BAMBOO CANES TOUGH AND STRONG
6 ft. long — \$1 per 100; \$6 per 1000; \$11 per 2000

They cost about 10 per cent. more than other kinds, and they are 10 times better.

STUMPP & WALTER CO., - 50 Barclay St., New York

RELIABLE SEEDS—Sow Now

Primula Obconica Grandiflora

new Hybrids as: Blood-red, Blue, Carmine, Pink, Purple, Violet, Pure-white, Compacta, Gigantea, Fringed Mixed Hybrids, each separate, Tr. Pkt. 50 cents, 6 Tr. Pkts. \$2.50.

O. V. ZANGEN
Seedsman. HOBOKEN, N. J.

C. C. MORSE & CO.

Address all communications to our permanent address
48 to 56 Jackson St., San Francisco, Cal.

The Largest Seed Growers
in the United States

BRECK'S SEEDS

For Farmer, Market Gardener and Florist
New Crop High Grade
Catalogues mailed free on application

Joseph Breck & Sons Corp.
47-54 NO. MARKET ST., BOSTON, MASS.

CAULIFLOWERS SEED CABBAGE SEED

HJALMAR HARTMANN & CO.,
12 Stormgade,
COPENHAGEN, DENMARK.

Burpee's Seeds
PHILADELPHIA

Blue List of Wholesale Prices mailed only to those who plant for profit.

FISKE SEED CO.
can supply new, to the florist for immediate use.
fresh seed
Aster Seed A Specialty
Special Florist List Free

H. E. FISKE SEED CO.
12 & 13 Faneuil Hall Square, BOSTON, MASS.

Look through the Buyers' Directory and Ready Reference Guide. You will find some good offers there also

Thorburn's Seeds

COLD STORAGE LILY OF THE VALLEY PIPS

COLD STORAGE LILIUM *Harrisii*, also SPIRAEA GLADSTONE, LILIUM *Auratum*, *speciosum album*, *speciosum rubrum*, Large Flowering Japan Iris, Cannas, etc.

For prices, state quantities required.

J. M. THORBURN & CO.
33 Barclay St., through to 38 Park Place
NEW YORK

Best Quality Fall Bulbs

It is to your advantage to place your order early. Send us a list of your wants and we will quote you rock-bottom prices. Copy of our Florists' Bulb Catalogue will be sent upon request. Catalogues now ready.

VICK'S SUPERB PANSY SEED

All the best varieties in separate colors
VICK'S SUPERB MIXTURE

the best strain from all the leading named sorts
1-8 oz. 75c. 1-4 oz. \$1.50 Ounce \$5.00

JAMES VICK'S SONS, Rochester, N. Y.

CYCLAMEN

Farquhar's Giant Strain

Unsurpassed for size of flowers.

Giant Crimson Giant Pink
Giant White Finest Mixed
Giant Excelsior, White with
Claret Base

100 seeds, \$1.25; 1000 seeds, \$10.00.

R. & J. FARQUHAR & CO.

6 & 7 So. Market St., Boston, Mass.

QUALITY SEED BULBS PLANTS
 SEND FOR CATALOGUE
ARTHUR T. BODDINGTON
 342 West 14th St., New York.

EASTER PLANTS

**Azaleas, Baby Ramblers,
Hydrangeas, Lilies,
Geraniums**

In fine condition. Write for Prices

WM. W. EDGAR CO., Waverley, Mass.

Martial Bremond

WHOLESALE GROWER OF FRENCH BULBS

— OLLIOULES, FRANCE —

A superior quality supplied at market prices. Shipments made direct. Cases marked to order.

Sole Agents

RALPH M. WARD & COMPANY
12 West Broadway - - NEW YORK

LIBRARY NOTES.

Last week's notes on a new book on the rose were from the pen of Mr. Payne.

As a rather keen collector of rare old gardening books, I can only express my regret that there is not the same facility for acquiring them that there is for getting the new ones. Whenever one goes or whatever one wants it is always the same story, that all the old gardening works are being bought up by Americans. Books that a few years ago could have been bought on the Quais in Paris for a few cents each are now almost unobtainable for the same number of dollars. By this I am encouraged to think that the literary interest in modern gardening among Americans is also keen and therefore I continue my Library Notes for their special information. The first to claim attention in this week's notes is:

The Flower Garden, by T. W. Sanders. The author of this bulky little octavo is a well-known horticultural writer, and editor of one of our most popular gardening papers. He is a practical gardener of many years' experience, and has among much other literary work edited and brought up to date many of the books written by the famous Shirley Hibberd. The Flower Garden, now presented to the public, is indeed one of the most comprehensive books on outdoor flower gardening we have, and is divided into three main divisions—first, the formation and management; second, the arrangement of plants, hardy and half-hardy of every description; third, ornamental trees and shrubs suitable for the open air in English gardens. It can easily be understood that in a work extending over 450 pages these main divisions are capable of infinite sub-divisions.

The general plan of the work is systematic and in orderly sequence. A nicely gotten up book, brimful of practical information and an excellent present for any enthusiastic garden amateur. \$2.00.

Sweet Peas and Their Cultivation, by Charles H. Curtis. A capital little manual by the secretary of our National Sweet Pea Society. It is a neat little treatise that ought to be on the shelves of every lover of the flower. Price 36 cents

La Revue Chrysanthemiste 123

Rue Baudin, Paris). This is a new monthly journal devoted to the chrysanthemum, and is the official organ of a new French society for the cultivation of the popular autumn flower. In form and contents it is somewhat similar to "Le Chrysanthème" which has been running now for thirteen years. Free to members.

C. HARMAN PAYNE.

ORCHIDS

We are at present booking orders for freshly imported Orchids for delivery 1905, of all leading kinds at reduced prices. We have just received the following:—*Oncidium Sarcodes, O. Forbesii, O. Tigrinum* and *Sophranites, Grandiflora* and *Coccinea*.

LAGER & HURRELL, Summit, N. J.

New Violet BOSTON

In introducing this new variety to the trade I wish to state that I have been growing it in quantity for the past two years and do not hesitate to state that it is entirely distinct, a strong grower, a free bloomer, and the first single violet in cultivation. Ready for distribution in April and May. Orders booked now. \$2 per 12; \$12 per 100; \$100 per 1000. 500 at 1000 rate.

WILLIAM SIM, CLIFTONDALE, MASS.

ROBERT CRAIG CO.

ROSES, PALMS,

and Novelties in Decorative Plants

MARKET and 49th STREETS., PHILADELPHIA, PA.

NEPHROLEPIS SCOTTII

in the following sizes, extra good value

25c., 50c., 75c., and \$1

Grand Specimen Plants at \$3, \$4, \$5, \$6.

JOHN SCOTT

Rutland Road and E. 45th St.

Tel. 2350 Bedford BROOKLYN, N. Y.

NEP. WHITMANI

2 1/4 in., \$5.00 per 100

NEP. WHITMANI

3 1/2 in., \$25.00 per 100

BOSTON FERNS

2 1/4 in., \$3.00 per 100

H. H. BARROWS & SON Whitman, Mass.

FERNS

Boston, 4 inch 12c, 5 inch 25c.

Plersonii, 3 inch 8c.

Elegantissima, 2 1/4 inch 6c, 3 inch 10c,

4 inch, 15c.

BAUR FLORAL CO., Erie, Pa.

ORCHIDS

Largest Importers, Exporters, Growers and Hybridists in the World

Sander, St. Albans, England
and 235 Broadway, Room 1
NEW YORK CITY

Imported Orchids

JUST TO HAND

Laelia Purpurata
Cattleya Intermedia
Cattleya Mossiae

JULIUS ROEHRS CO.,

The Orchid Nurseries RUTHERFORD, N. J.

ORCHIDS

We shall receive in about two weeks' time fine importation of *Dendrobium Wardianum, D. Phalaenopsis, D. Formosum giganteum*.

April: Most all the *Cattleyas, Vandas, Oncidiums, etc.* Write for price List.

GARRILLO & BALDWIN, Secaucus, N. J.

ORCHIDS

The largest importation of Orchids ever received in this country WILL ARRIVE next spring from Brazil, Colombia and Venezuela. If you intend putting in stock wait for these to arrive and we will quote the Lowest Prices in America.

ORDONEZ BROS., - Madison, N. J.

ORCHIDS for Spring Delivery

NEW IMPORTATIONS

Cattleyas, Laelias, Oncidiums, etc.

WRITE FOR PRICES

Now is the time to Pot Orchids. Best Quality of Peat, Moss and Baskets on hand.

JOSEPH A. MANDA, 191 Valley Road, WEST ORANGE, N. J.

In ordering goods please add "I saw it in HORTICULTURE."

COLD STORAGE

MULTIFLORUM LILY BULBS

7 to 9s

Delivery Immediate or as Ordered. \$45 per 1000

WOOD MOSS, 65c per b'dle.

D. RUSCONI, 128 W. 6th Street, Cincinnati, O.

JAPANESE
THE YOKOHAMA NURSERY CO. NEW YORK.
31 BARCLAY STR.
LILIES
PLANTS
BAMBOO STAKES



CHOICE SINGLE FLOWERING ENGLISH WALL-FLOWER FOR EASTER BLOOMING

We have an elegant lot of these old-fashioned favorites, field-grown plants, which were potted up into four-inch pots during the latter part of September and which have been carried through the winter in cold frames and are now in prime condition to move. If placed in a carnation house temperature they will come in nicely for Easter, at which time there will be ready sale, at remunerative prices.

Strong, bushy, shapely plants from four-inch pots, \$1.25 per dozen; \$8.00 per 100; \$70.00 per 1000.

HENRY A. DREER, 714 Chestnut St., Philadelphia, Pa.

CHRYSANTHEMUMS

Novelties for 1908 in 2½ inch Pots, Ready for Immediate Shipment

MRS. NORMAN DAVIS. Pure white, an improved Mme. Carnot. Best exhibition white out.
DOROTHY GOLDSMITH. Might be called a bronze F. S. Vallis, and easy doer. The finest bronze out.
KATIE PALGRAVE. A clear, waxy white, resembling Mrs. A. T. Miller, but fuller, and two weeks later.
MRS. SOUTHGATE. As large as F. S. Vallis, but a brighter yellow.

O. H. BROOMHEAD. An immense, solid bloom, rich deep rose, with sturdy dwarf habit.
W. MEREDITH. Dark crimson, with gold reverse. An enlarged Edwin Molyneux. A reliable variety.
MARY DONELLAN. A splendid deep yellow.
JOSEPH STONEY. Best exhibition crimson.
HAROLD WELLS. Pure white. A monster.
MRS. J. C. NEIL. Soft canary yellow. An improved Cheltoni.

50c each, \$5.00 per doz., \$35.00 per 100

Also a Large Stock of the Leading Chrysanthemums on Hand. Varieties and Prices on Application.

The New Double Flowering Blue Lobelia **KATHLEEN MALLARD** Ready for Immediate Shipment. 25c each, \$2 50 per doz.

Scott Bros., ELMSFORD NURSERIES, Elmsford, N. Y.

TELEPHONE 474 TARRYTOWN

DAHLIAS

Novelties and Standard Varieties

Our Leaders—**RUTH FORBES** and **NEWPORT**
Send for free catalogue

WILLIAM F. TURNER & COMPANY
New Bedford - - - Mass.

DAHLIAS. Now is the time to place your order for bulbs which will insure you getting named varieties in any quantity; prompt delivery.

DAVID HERBERT & SON,
Successors to L. K. Peacock, Inc.
ATCO, N.J.

100,000 DAHLIAS

Premium Stock, guaranteed true to name.
500,000 large Flowering Gladioli, hundreds of colors and variations mixed. Wholesale prices on application. Order now for spring delivery. Catalogue free.
J. L. MOORE, Northboro, Mass.

Special Offer

Lilium Auratum, 11 to 13 in.

\$4 00 per 100, \$35.00 per 1000

Double Begonia Bulbs

UNDER COLOR

\$3.00 per 100, \$25.00 per 1000

V. H. HALLOCK & SON
QUEENS, NEW YORK

In writing advertisers kindly mention HORTICULTURE.

ROOTED CARNATION CUTTINGS

Only the Best Varieties
CHICAGO CARNATION CO., JOLIET ILL.

Single Chrysanthemums

ARE THE CRAZE

for the time being.

Are you in line to meet the demand?

I have now ready

KATIE COVELL, ROB ROY, HELEN TOTTY, HAROLD BISHOP, MRS. UNTERMEYER, ANNA SPANGLE,

and others, at

\$2.00 per doz., \$15.00 per 100.

I also carry a full line of novelties and standard varieties of

Chrysanthemums, Carnations and Roses

CHAS. H. TOTTY, MADISON, N. J.

CARNATIONS

WINONA—The True Pink

\$12.00 per 100, \$100.00 per 1000

	Per 100	Per 1000
Red Chief.....	\$5.00	\$40.00
Arlstocrat.....	7.00	50.00
Winsor.....	6.00	50.00
Beacon.....	6.00	50.00
White Perfection.....	3.00	25.00
Rose Pink Enchantress.....	3.00	25.00
Enchantress.....	3.00	25.00
Lady Bountiful.....	3.00	25.00

F. DORNER & SONS CO., LAFAYETTE, IND.

JOHN E. HAINES Bethlehem, Pa.

is the place to order rooted-cuttings of the following varieties for 1908.

John E. Haines, red	} Per 100 Per 1000	\$6.00 \$50.00
Imperial variegated		
Pink Imperial, Pink		
Enchantress, Light Pink		

Place your orders early for Jan. delivery.

Carnation Cuttings

Both standard varieties and novelties. Stock guaranteed to be first-class. Address,

S. S. SKIDELSKY

1741 North 18th Street, Philadelphia

PRICES QUOTED IN THESE COLUMNS ARE FOR DEALERS ONLY

When Writing to Advertisers Please Mention Horticulture

JOHN BREITMEYER'S SONS

Cor. Miami and Gratiot Aves.
DETROIT, MICH.

Artistic Designs . . .
High Grade Cut Blooms

We cover all Michigan points and good
sections of Ohio, Indiana and Canada

William J. Smyth FLORIST

Cor. Michigan Ave. and 31st St., CHICAGO

We ship to all points in Illinois and Iowa.

Phones: Douglas 744, Douglas 523, Douglas 740

M. C. and J. E. HAUSWIRTH

232 Michigan Ave.

CHICAGO

AUDITORIUM ANNEX

Tel. Harrison 585

SAMUEL MURRAY Florist

Coates House Conservatory

1017 BROADWAY, KANSAS CITY, MO

Both 'Phones 2670 Main

FRED C. WEBER FLORIST

4326-28 ST. LOUIS, MO.
OLIVE STREET

Established 1873
Long Distance Phone Bell Lindell 676



WASHINGTON,
D. C.

GUDE'S

Geo. H. Cooke FLORIST

Connecticut Avenue and L Street
WASHINGTON, D. C.

The Park Floral Co.

J. A. VALENTINE
Pres.

DENVER, COLORADO

WILLIAM L. ROCK FLOWER CO.

KANSAS CITY, MO.

will carefully execute orders for Kansas City
and any town in Missouri or Kansas.

Of Interest to Retail Florists

CHICAGO Southern jonquils have been a leader as the quantity shipped in has forced prices to a low figure decidedly to the retailer's advantage. The green flower business for St. Patrick's Day must have been overdone as a great many carnations, roses, tulips, etc., were seen on the following day. It is a speculation anyway. A large number of flowers must be colored to make a fair window display and apparently the novelty of green flowers has worn off. Where in other years a customer would select a dozen this year one or two was the limit.

DETROIT Springlike weather brought forth a large increase of counter trade over previous weeks, and store openings created very generous calls for large flowering plants and plant baskets. While twice we came near to having a glut the wholesaler has escaped with only a very slight infection by this microbe. A. W. Farrand is bringing fine white lilac from American grown trees to this market. Easter lilies promise to be very good but somewhat shorter in stem than in previous years. There will be plenty to go around. Some florists are already preparing cool storage houses to keep azaleas, lilacs, etc., which may be badly needed owing to the lateness of Easter.

NEW RETAIL FLOWER STORES.

T. L. Metcalfe, Jackson, Tenn.; H. H. Crawford, manager.

J. C. Hatcher, Schenectady, N. Y.; George Hatcher, manager.

Charles I. Bean, Springfield, Mass. Frank Vogt, 4138 Cottage Grove Ave., Chicago.

Charles A. Towns, Tilton, N. H. Myers Bros., Eleventh Ave. and 13th St., Altoona, Pa.

A GREAT ASTER.

Of the modern type of aster evolved within the past few years, the strain now being offered to the trade by Charles A. Kibbe of Elmhurst, Ill., stands in the first rank. These superb asters with their enormous blooms carried on stems from two to three feet high rival the chrysanthemum in effectiveness, and the class is indispensable to every florist.

INCORPORATED.

Kelley Floral Co., St. Louis, Mo.; E. G. Kelley, J. F. Wohlfarth, Anna Wohlfarth; capital, \$2,000.

NEWS NOTES.

W. M. Eldridge & Co., Wilkes Barre, Pa., will dispose of their stock and fixtures and retire from business.

W. D. Conrad has been appointed by Judge Holt receiver for Alfred Van Praag, florist, 1207 Broadway, New York, with bond of \$500.

The store of Henry Burt, Syracuse, N. Y., which was damaged by smoke from a near-by fire last week, was quickly put in order and business now is going on as usual.

Florists Out of Town

Taking orders for delivery in
New York or Vicinity
can have them filled in best
manner and specially delivered by

Thomas Young, Jr.

500 Fifth Ave., New York City
Telephone 847 Bryant.

ALEX. McCONNELL

571 FIFTH AVENUE
NEW YORK CITY

Telegraphic orders forwarded to any part of the United States, Canada, and all principal cities of Europe. Orders transferred or intrusted by the trade to our selection for delivery on steamships or elsewhere receive special attention.

Telephone Calls, 487 and 488 38th St.
Cable Address, ALEXCONNELL

WILLIAM H. DONOHUE

FLORAL DECORATOR

17 East 28th St., New York

Special Attention to Theatre
and Steamer Orders, and reliable
deliveries guaranteed.

DAVID CLARKE'S SONS

Deliver orders from any part of the country to
New York City

Or OUT-GOING STEAMERS

Write or telegraph

2139-2141 Broadway, New York
Telephone 1552-1553 Columbus

M. A. BOWE

In the Heart of New York City

1294 Broadway

Tel. 2270, 38th St. NEW YORK

Our Motto -- The Golden Rule.

YOUNG & NUGENT

42 West 28 St., NEW YORK

"FLOWERS BY TELEGRAPH"

Flower Deliveries

in Brooklyn and other Long Island Points
New York City, New Jersey, etc. At Theatres,
Hotels, Steamers or Residences.

WILSON

Fulton St. and Greene Ave., Brooklyn, N.Y.

ALBANY, N. Y.

EYRES

Flowers or Design Work

DELIVERED IN ALBANY AND VICINITY
ON TELEGRAPHIC ORDER.

11 NORTH PEARL ST., ALBANY, N. Y.

JACOB SCHULZ, 644 Fourth Ave.,
LOUISVILLE, KY.

Cut Flowers of BEST QUALITY in season
delivered promptly to any address.

Write, Telegraph or Telephone.
Cumberland and Home Phones 223 and 984

BUSINESS CHANGES.

Myers Bros., Altoona, Pa., have moved from 1110 1-2 Eleventh Avenue to larger and better equipped quarters in the Christy building.

Frank J. Clark, Trenton, N. J., has given up his store at the Opera House building and opened at 119 Broadway on March 17.

F. W. Heroman of Baton Rouge, La., has admitted his son, Fred I., into partnership, and the firm name hereafter will be F. W. Heroman & Son.

It is stated that James S. Wilson will soon leave Western Springs, Ill., to start in business for himself at Des Moines, Ia., where he has taken a place and put his son in charge for the present.

PROMPT DELIVERY IN BOSTON

AND ALL NEW ENGLAND POINTS
HOUGHTON & CLARK
396 Boylston St., Boston, Mass.



BOSTON'S BEST
In Quality and Design

Can be relied upon when you transfer your retail orders to

EDWARD MACMULKIN
194 Boylston Street, Boston

Send flower orders for delivery in
BOSTON

and all
NEW ENGLAND POINTS
THOS. F. GALVIN
124 Tremont St., Boston

TRANSFER

Your orders for flower or plant delivery in Eastern New England to

JULIUS A. ZINN,
2 Beacon St., Boston.
Fine Design Work a Specialty.

YALE Orders for flower deliveries to Yale College and all other Connecticut points carefully filled and delivered by
J. N. CHAMPION & COMPANY
1026 CHAPEL STREET NEW HAVEN, CONN.

ATLANTA FLORAL CO.
41 Peachtree Street, ATLANTA GEORGIA.

HART'S HANDY HANDLE

"At Easter-time, with a little chiffon decoration, and the Handle, we were able to increase the value of plants from 50% to 100%."— H. E. WILSON.

Write for descriptive circular and prices

GEO. B. HART, 24 Stone St., Rochester, N. Y.

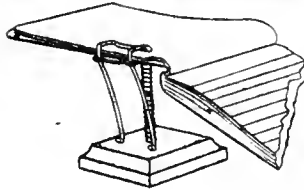

4 in 1
Spring Spindle File and Stenographer's Note Book Holder. Makes no holes in paper. papers can be removed without displacing others: has no sharp point to tear the flesh. Holds note book firmly and at right height for typewriter. Can be used as hat holder, or as support for book to read from. Used by book-keepers, 50,000 IN USE. Single file 25c post-paid. See large ad, Weekly Board File, page 383, Horticulture, March 21.
A. F. LEWIS MFG. CO., E. Boston, Mass.



PERSONAL.

Albert Greer is starting in the vegetable growing business at Vancouver, Wash.

George Reid has taken a position at Blantyre, R. W. Patterson's estate at Lenox, Mass.

Philip Breitmeyer and wife of Detroit have returned from a two weeks' trip to Florida.

George M. Geraghty of New York has taken a position as manager of J. H. Dunlop's store at Toronto, Can.

B. E. Vandervoort is starting in the nursery business at Normal, Ill., and his packing sheds are already under way.

Herman Dorner, of Lafayette, has been appointed professor of floriculture at the University of Illinois, Champaign. Mr. Dorner is a graduate of Purdue University.

Charles P. Price, who since July, 1896, has been superintendent of the Middlesex Fells reservation under the direction of the metropolitan park commission of Massachusetts, has tendered his resignation, to take effect April 1, and it has been accepted. His successor will be Albert N. Habberly.

David McIntosh, who has been gardener on the Bell estate at Newport, R. I., during the past twenty years has moved to Tuxedo park, N. Y., to take charge of an estate recently purchased there by Mrs. C. M. Bell, in whose employ he has been at Newport. David McIntosh was for five years, and up to his change of residence, secretary of the Newport Horticultural Society.

NEWS NOTES.

The first sale of the fruit auction Co., New York, will be held on Wednesday, April 1, at 204 Franklin street, and the sales will continue at the same hour on following days until further notice.

It is stated that a large greenhouse is soon to be built at Eastport, Me., to meet the demand in that vicinity for plants and flowers.

We understand that the Plant Growers' Market will vacate their premises at 43 W. 27th street, New York, on May 1.

BOSTON FLORIST LETTER CO.
Manufacturers of FLORISTS' LETTERS

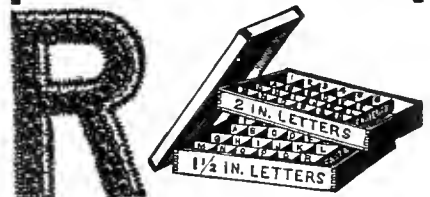

This wooden box nicely stained and varnished, 18x30x12, made in two sections, one for each size letter, given away with first order of 500 letters

Block Letters, 1 1/2 or 2 inch size per 100, \$2. Script Letters, 3. Fastener with each letter or word. Used by leading florists everywhere and for sale by all wholesale florists and supply dealers

N. F. MCCARTHY, Manager
66 Pearl Street, BOSTON, MASS.

Large Plants, Bay and Box trees, Palms, Hydrangeas, Agaves, etc., will soon need re-potting. Use the Mission Plant Box if you want the most durable and appropriate box made. Very reasonable in price. Made of pine or cypress.

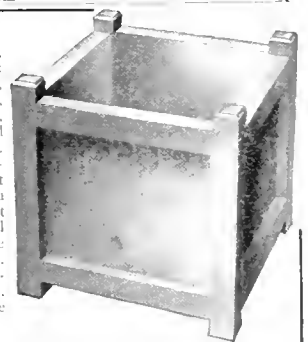

Write for Prices.

Wagner Park Conservatories
SIDNEY, OHIO.

The "Japana" Cut Flower Holder

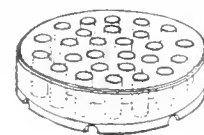

A handy article for florists. Sells to the trade on sight. Made of glass in three sizes. The "Anglais" Table Decoration, something entirely new, long needed. The florist and housewife will appreciate this article, as it simplifies the art of table decorating.

Ask for catalog.

M. V. GARNSEY, Dept. M,
130 Waiola Ave., La Grange, Ill.

KORAL SCRIPT LETTERS AND EMBLEMS

ONCE USED ALWAYS USED
For sale by all first class supply houses. Made by
KORAL MFG. CO.
26 Hawley St., Boston

American Beauty Roses
 Orders in any quantity promptly filled. All grades.
Acacia pubescens
 Sprays of this popular golden spring beauty in regular daily shipments, \$1.50 and \$2.00 per bunch.

The Leo Niessen Company
 1209 Arch St., Philadelphia, Pa.
 Open from 7 a. m. to 8 p. m.

VALLEY
The BEST
\$3.00 per 100
 New buyers always come again. Superior quality counts.

S. S. PENNOCK-MEEHAN CO.
 1608-1620 Ludlow St. PHILADELPHIA
 "The" Wholesale Florists of Philadelphia

EVERYTHING SEASONABLE IN
CUT FLOWERS
 EDWARD REID, Wholesale Florist
 1526 Ranstead St., PHILADELPHIA
 STORE CLOSERS 8 P. M.

CHAS. W. MCKELLAR
 51 WABASH AVE., CHICAGO
 Western Headquarters for Choice Orchids
 Valley, Roses and all Cut Flowers

PETER REINBERG
 WHOLESALE
CUT FLOWERS
 51 Wabash Av., Chicago, Ill.
 In writing advertisers, mention Horticulture

CUT FLOWER BOXES
EDWARDS FOLDING BOX CO
 MANUFACTURERS
 PHILADELPHIA, PA.

AMERICAN BEAUTY and all other ROSES
LILY OF THE VALLEY, CARNATIONS
WELCH BROS., 226 Devonshire St., Boston, Mass.

THE BEST ON THE MARKET
W. E. MCKISSICK WHOLESALE FLORIST
 PHILADELPHIA
 1619-1621 RANSTEAD ST.

DAILY CONSIGNMENTS
 From 40 to 60 Growers
 We can care for your cutflower wants to advantage.
E. F. WINTERSON CO.
 45-47-49 WABASH AVE., CHICAGO

Rice Brothers
 115 N. 6th Street, MINNEAPOLIS, MINN.
WHOLESALE FLORISTS and SUPPLIES
 CUT FLOWERS received twice daily, and can fill your orders to your satisfaction. A complete line of Hardy Greens—WILD SMILAX, BOXWOOD, HARDY FANCY FERNS, GALAX LEAVES.
 Write for quotations on large quantities.

WHOLESALE FLOWER MARKETS—TRADE PRICES—Per 100 TO DEALERS ONLY

	CHICAGO March 23	TWIN CITIES March 23	PHILA. March 23	BOSTON March 26
ROSES				
Am Beauty, Fancy and Special...	25.00 to 30.00	45.00 to 60.00	20.00 to 25.00	23.00 to 25.00
" " Extra	16.00 to 20.00	30.00 to 40.00	12.00 to 15.00	15.00 to 20.00
" " No. 1	8.00 to 12.00	13.00 to 25.00	6.00 to 8.00	8.00 to 10.00
" " Lower grades	4.00 to 6.00	10.00 to 15.00	3.00 to 5.00	4.00 to 6.00
Bride, 'Maid, Fancy & Special	4.00 to 8.00	8.00 to 10.00	8.00 to 12.00	6.00 to 8.00
" " Extra and No. 1	4.00 to 6.00	6.00 to 8.00	4.00 to 6.00	3.00 to 5.00
" " Lower grades	2.00 to 4.00	2.00 to 4.00	2.00 to 3.00	1.00 to 2.00
Killarney, Richmond, Fan & Sp.	6.00 to 8.00	8.00 to 10.00	8.00 to 12.00	8.00 to 10.00
" " Lower grades	2.00 to 4.00	3.00 to 6.00	3.00 to 5.00	2.00 to 6.00
Chat-nay, Wellesley, Fan & Sp.	6.00 to 8.00	8.00 to 10.00	8.00 to 12.00	4.00 to 8.00
" " Lower grades	2.00 to 4.00	3.00 to 6.00	3.00 to 5.00	1.00 to 3.00
Golden Gate, Ivory	4.00 to 6.00	5.00 to 8.00	3.00 to 8.00	1.00 to 6.00
CARNATIONS				
Fancy and Novelties	2.00 to 3.00	2.50 to 3.50	3.00 to 4.00	1.00 to 2.00
Ordinary	1.00 to 2.00	1.50 to 2.00	1.50 to 2.00	.50 to .75
MISCELLANEOUS				
Violets	.25 to .50	.50 to 1.00	.50 to .75	.25 to .50
Cattleyas	40.00 to 50.00	50.00 to 50.00	50.00 to 60.00	50.00 to 60.00
Cyripediums to to to	8.00 to 10.00
Lilies	10.00 to 12.00	10.00 to 15.00	12.50 to	8.00 to 10.00
Lily of the Valley	2.00 to 3.00	2.00 to 3.50	2.00 to 4.00	2.00 to 3.00
Daisies to to	1.00 to 2.00 to
Daffodils	2.00 to 3.00	2.50 to 3.00	1.50 to 2.00	1.00 to 2.00
Tulips	2.00 to 3.00	2.50 to 3.00	2.00 to 3.00	1.00 to 3.00
Mignonette to 4.00	4.00 to 6.00	3.00 to 4.00	3.00 to 4.00
Gardenias to 25.00	40.00 to 50.00	10.00 to 15.00	25.00 to 40.00
Lilac per bunch to 1.00	1.00 to 1.50	.75 to .50	1.00 to 1.50
Sweet Peas	.50 to .75 to 1.00	.75 to 1.00	.25 to .50
Adiantum	50 to 1.00	.75 to 1.00	1.00 to 1.50	1.00 to 1.50
Whicmanii Fronds to to	3.00 to 5.00	2.00 to 3.00
Smilax	10.00 to 12.00	12.00 to 15.00	15.00 to 20.00	10.00 to 12.00
Asparagus Plumosus, strings	35.00 to 50.00	35.00 to 50.00 to 50.00	25.00 to 50.00
" " & Spren. (100 bchs.)	25.00 to 35.00	35.00 to 50.00 to 50.00	15.00 to 50.00

H. BAYERSDORFER & CO.
 The Florists' Supply House of America
 Send for illustrated Catalogue
 1129 ARCH ST., PHILA., PA.

Alex Mann, Jr. Co. Inc.
 Wholesale Dealer in
Florists' Supplies and Cut Flowers
 White Doves, \$9.00 per doz.
 Galax Leaves.
 1125 Polk Street, San Francisco, Cal.

E. A. BEAVEN
Southern Wild Smilax, Log Mosses,
 Natural and Perpetuated— at Wholesale,
EVERGREEN, ALABAMA.

ROBERT J. DYSART,
 Public Accountant and Auditor
 Simple methods of correct accounting especially adapted for florists' use.
 Books Balanced and Adjusted
 Merchants Bank Building
 28 STATE ST., BOSTON
 Telephone, Main 58.

J. B. Murdoch & Co.
 Wholesale Florists
FLORISTS' SUPPLIES
 714 Penn Ave., PITTSBURG, PA.
 Long Distance Phone 1435 Court.

H. J. Smith
 HARDY CUT FERN DEALER, ETC.,
 Write for Prices
 HINSDALE, MASS.

Flower Market Reports.

BOSTON The market is still dull and lifeless. Conditions have not improved over last week. Flowers of all descriptions are plentiful with but small demand. Carnations are in fine condition, also roses, especially American Beauty. Lilies are being received in large quantities, and if stock continues to come in as fine shape as at present good results are expected from the Easter trade.

CHICAGO As the Lenten season advances business holds about the same and the wholesalers have no complaint. A great many split carnations are shipped in but ready sale is found for them to the sidewalk vendors and to department stores in out of town places that put on sales of carnations at low prices. American Beauties are more plentiful and of good quality. Southern jonquils are coming in large quantity and selling very cheap. This stock has a tendency to hurt the forced bulbous stock in prices. Azaleas, tulips and jonquils in pots, also cinerarias, are abundant in the plant line.

INDIANAPOLIS The market contains much more stock than the demand is using up. Wholesale prices appear to be lower than usual considering the quality and time of year. The trade in flowering plants seems to be far in excess of that of cut flowers. Beauties and all tea roses are first-class and are in quantity more than sufficient for the needs of the market. Carnations and bulbous flowers are abundant and can be had at the lowest market figures. Sweet peas are bringing good returns and no trouble is experienced in disposing of select stock. Lilac is seen in quantity but difficult to move. A big improvement in trade is reported by retailers in all sections of the city. Present indications do not point to any material change in prices.

PHILADELPHIA We are happy to be able to report that the market here is picking up a little. Carnations cleaned up much better and with smaller receipts prices are bound to improve. The demand all along the line was better, and while no decided advance has taken place in prices of the leading staples, a much better tone prevails. American Beauty roses shortened up considerably. Richmond continues fine but Liberty is a little off color. Bridesmaid and Killarney lead in the pink section, with the latter in best demand. A few of the new Mrs. Jardine are coming in and are eagerly snapped up. The violet situation improved greatly Friday and Saturday. The singles are sagging a little as to quality. It is thought that the cold frame crop will not last until Easter. Sweet peas are still very good and selling well. Southern daffodils are very plentiful and go mostly to the street men. The local product has the call, being larger, better substance, fresher and of the high-toned varieties such as Emperor, Empress, etc. These

1000 Strings of Smilax MUST BE SOLD BEFORE EASTER

Strings 6 feet long. 15 cents each.
Let me send sample lot.

VERN L. SCHLURAFF, - - - ERIE, PA.

go to the best stores and bring good prices. Paper Whites and Romans are nearly over. Easter lilies and callas are plentiful and go fairly well. Dendrobium Wardianum and Cattleya Schroderae lead in orchids. Cypripediums are about done.

TWIN CITIES The past week showed no changes to speak of. Business during the whole month has been good, with the exception of a few stormy days. Bulbous stock is going up a trifle. Chicago is sending in quite a lot of cheap flowers, especially roses in the lower grades, lilies and other bulbous flowers. There will be a nice lot of Easter lilies, azaleas, rhododendrons, astilbes, etc., on hand for Easter.

WASHINGTON The market is still demoralized by the excessive glut due to the beautiful weather and to the quiet of the Lenten season. Outdoor bulbs are beginning to flower now which will further help to lower prices of all other flowers. Carnations still remain of fine quality, but violets are very poor. Roses, even American Beauties, have gone tumbling down in price and we cannot reasonably hope for any better report before the Easter rush is on.

NOTES FROM TWIN CITIES.

Mr. Theodore Wirth left on March 19 for the meeting of the executive committee of the S. A. F., and also to attend the executive meeting of park superintendents to arrange for the next convention which will be held in Minneapolis.

J. F. Withers, who had been in Minneapolis for ten days lecturing on the treatment of trees and landscape gardening, accompanied Mr. Wirth. Mr. Withers also gave a lecture before the students of the State Agricultural School and before the Twin City Florists' and Gardeners' Club at their meeting at Holm & Olson's in St. Paul on March 17. All the lectures were very well attended and much appreciated.

NEWS NOTES.

Azalea Star of Somergen will be shown for first time at the Quinquennial, Gh-nt, in April, 1908.

The Denison (Texas) Civic Improvement League has just completed its second annual distribution of flower seeds through the public schools, which proved a great success, more than seven thousand packets being furnished for planting in home yards. Prizes will be offered for the best results obtained from the planting of these seeds and liberal prizes will be offered for the greatest improvement of home yards under a plan very successfully employed last season.

DURING RECESS.

The first meeting of the New York Florists' Bowling Club was held at the office of W. E. Marshall. Eighteen members were enrolled and officers chosen as follows: President, W. E. Marshall; secretary, J. Austin Shaw; treasurer, J. A. Manda. Dues were fixed at fifty cents a night. Only members of the New York Florists' Club will be eligible for membership.

After the transaction of business, bowling was indulged in, and among the best scores were the following:

A. Rickards.....	124	236	148
W. Rickards.....	130	167	129
W. E. Marshall.....	128	163	138
Mr. Schreiner.....	137	181	186
Jos. Feurich.....	173	165	192
J. A. Manda.....	156	171	181

Competition for President Traendly's transportation offer begins on April 3, and twenty games are to be rolled; the five winners must average 155 in the twenty games. The contest promises to be a lively one.

CLUB AND SOCIETY NOTES.

The New England Dahlia Society will hold an exhibition on September 17, 18, 19, at Lorimer and Gilbert Halls, Tremont Temple, Boston.

At the meeting of the Maryland Horticultural Society at Hotel Rennett, Baltimore, March 8, arrangements were made for a summer meeting at White Marsh, September 22, on invitation of R. Vincent, and for the winter meeting on December 1, 2, 3 in Baltimore.

The Winnipeg Florists' Association was formed at Winnipeg, Man., on February 27, with officers as follows: President, Mr. Eurchart; vice presidents, Messrs. Stolper and Akins; secretary, Mr. Birch; treasurer, Miss Sidle; corresponding secretary, Mrs. Kempster.

The Milwaukee (Wis.) Florist Club gave its fifth carnation exhibition on March 5, which was a decided advance over any previous show. Competition was admitted only between the local growers and N. Zweifel secured a majority of the prizes. Heitman & Baerman, A. Manke & Sons, Mueller & Schroeder and C. C. Pollworth Co. being other winners. Special mention was made of carnations Winona from F. Dorner & Sons Co., Aristocrat, White Enchantress and Andrew Carnegie from Chicago Carnation Co. F. P. Dilger showed fine bulbous flowers; E. G. Hill Co. Rhea Reid and Pohlmann Bros. Mrs. Potter Palmer roses.

The KERVAN CO. 113 W. 28th ST. New York

WHOLESALE DEALERS
Fresh cut Palmetto & Cycas Palm Leaves, Galax, Leucothoe, Ferns and Mosses. All Decorating Evergreen.

JOHN YOUNG
WHOLESALE FLORIST
 Finest American Beauties and Carnations
 51 West 28 St. - NEW YORK

FORD BROTHERS
 48 West 28th Street, NEW YORK
FINE ROSES FANCY CARNATIONS
 A Full Line of ALL CUT FLOWERS
 Telephone, 3870 or 3871 Madison Square

H. E. FROMENT,
 Wholesale Commission Florist,
 Choice Cut Flowers,
 57 West 28th St., :: NEW YORK.
 Telephones: 2200, 2201, Madison Square.

The Reliable Commission House
 Richmond Roses and Rich Flowers
 of all varieties
JOS. S. FENRICH
 110 W. 28th Street, New York
 Tel. 324-325 Madison Square

Established 1891 BUY FROM SHIP TO TRY
ALFRED H. LANGJAHR
 All Choice Cut Flowers In Season
 55 West 28th St., New York
 Telephone 3924 Madison Square.

JOHN I. RAYNOR
Wholesale Commission Florist SELLING AGENT FOR LARGEST GROWERS
 A full line of Choice Cut Flower stock for all purposes. Comprises every variety grown for New York market, at current prices
 TEL. 1998 MADISON SQUARE 49 W. 28 St., New York City

Walter F. Sheridan
 Wholesale Commission Dealer in
CHOICE CUT FLOWERS
 39 West 28th Street, New York
 Telephone: 3532-3533 Madison Square

HEADQUARTERS FOR NOVELTIES
ORCHIDS A SPECIALTY
 THE HIGHEST GRADE OF VALLEY ALWAYS ON HAND
 GARDENIAS, DAISIES, ROSES AND CARNATIONS
JAMES McMANUS, Telephone 759 Mad. Sq. 42 W. 28th St., New York

PHILIP F. KESSLER 55 & 57 W. 26th St., New York City
 Commission Dealer, Wholesale Buyer and Seller of
 Open from 5 a. m. to 6 p. m. Sunday till 10 a. m.
 Tel., 5243 and 2921 Madison Sq. Res., 345 J., Newtown.
CUT FLOWERS
 Finest Lilies in the Market Every Day in the Year.

WHOLESALE COMMISSION FLORIST
J. K. ALLEN 106 W. 28 ST. NEW YORK
 Telephone 167 Madison Sq.
 OPEN 6 A. M. DAILY
 We have a good regular outlet for seasonable flowers

NEW YORK QUOTATIONS PER 100—TO DEALERS ONLY

	Last Half of Week ending Mar. 21 1908	First Half of Week beginning Mar. 23 1908	Last Half of Week ending Mar. 21 1908	First Half of Week beginning Mar. 23 1908
Roses				
Am. Beauty, Ian and sp.	10.00 to 15.00	10.00 to 15.00		
" extra	5.00 to 8.00	5.00 to 8.00		
" No. 1	3.00 to 5.00	3.00 to 5.00		
" Lower grades to 1.00 to 1.00		
Bride, 'Mald, Ian and sp.	4.00 to 8.00	4.00 to 8.00		
" " extra	2.00 to 3.00	2.00 to 3.00		
" " lwr. grds. to 1.00 to 1.00		
Killarney, Richmond, fancy & spec	6.00 to 10.00	6.00 to 10.00		
" " lower grades	2.00 to 4.00	2.00 to 4.00		
Chatenay, Wellesley, Ian, and spec.	6.00 to 8.00	6.00 to 8.00		
" " lower grades	1.00 to 4.00	1.00 to 4.00		
Golden Gate, Ivory	1.00 to 6.00	1.00 to 6.00		
Carnations, Fancy and Novelties	1.00 to 2.00	1.00 to 2.00		
" " Ordinary	.50 to .75	.50 to .75		
Violets	.20 to .30	.20 to .30		
Cattleyas	40.00 to 50.00	40.00 to 50.00		
Cypripediums	8.00 to 10.00	8.00 to 10.00		
Lilies	8.00 to 10.00	8.00 to 10.00		
Lily of the Valley	1.00 to 2.00	1.00 to 2.00		
Freesia	1.00 to 1.50	1.00 to 1.50		
Roman Hy., Paper White Nar.	1.00 to 1.50	1.00 to 1.50		
Daffodils	1.00 to 1.50	1.00 to 1.50		
Tulips	1.00 to 1.50	1.00 to 1.50		
Mignonette	2.00 to 4.00	2.00 to 4.00		
Gardenias	25.00 to 40.00	25.00 to 40.00		
Lilac per bunch to .75 to .75		
Sweet Peas	.50 to 1.00	.50 to 1.00		
Adiantum	.75 to 1.50	.75 to 1.50		
Smilax	8.00 to 12.00	8.00 to 12.00		
Asparagus Plumosus, strigs.	25.00 to 35.00	25.00 to 35.00		
" " & Spren. (100 bchs.) to 10.00 to 10.00		

B. S. SLINN, Jr.
 —WHOLESALE FLORIST—
 55 & 57 W. 26th St., New York City
 Tel., 3864 Madison Sq. Shipping Orders Solicited.
VIOLETS Roses and Carnations

TRAENDLY & SCHENCK
WHOLESALE FLORISTS
 Furnish best stock at fair prices all the year round Send for quotations on fall orders
 Tel. 798-799 Madison Sq. 44 West 28th Street, New York City

Edward C. Horan
Wholesale Florist
 55 WEST 28th ST.
 Tel. 1462 1463 Madison Square New York

Alexander J. Guttman
THE WHOLESALE FLORIST OF NEW YORK
 43 WEST 28th STREET
 PHONES. 1664-1665 MADISON SQUARE
ENOUGH SAID



HARDY CUT FERNS

Sphagnum Moss, Extra Large Bales, per bale, \$1.25. Fancy and Dagger Ferns our specialty. A trial order will convince you that we ship only first-class stock. Headquarters for Florists' supplies and wire work. All cut flowers in season. **BOXWOOD, per bunch 35c, 50 lbs. \$7.50.**

MICHIGAN CUT FLOWER EXCHANGE, INC.,

All 'phone connections

38-40 Broadway, Detroit, Mich.

FANCY and DAGGER

Extra fine, \$1.75 per 1000. Bronze and Green Galax, \$1.25 per 1000. Leucothoe Sprays, \$1.00 per 100, \$7.50 per 1000.

Headquarters in Western New York
FOR
ROSES, CARNATIONS
And all kinds of Seasonable Flowers
Wm. F. Kasting Co.
Wholesale Commission Florist, also Dealer in
Florists' Supplies and Wire Designs.
383-87 ELLICOTT ST.
BUFFALO, N. Y.
Give us a trial. We can please you.

FRANK S. HICKS & CO.
Wholesale Florists.
Open Now for Consignments of Cut Flowers.
52 West 28th Street, - New York City
Tel. 2920 Mad. Sq.

FRANK MILLANG
Wholesale Florist
Telegraphic Orders Filled and Delivered.
55-57 West 26th St., New York City.

Flowers and
Florists' Supplies
The best place in AMERICA to buy
BAY TREES
N. F. McCarthy & Co.
84 Hawley St., BOSTON, MASS.
Largest Dealers in Supplies in New England.

HENRY M. ROBINSON & CO.
Wholesale and Commission
— FLORISTS —
Hardy Cut Evergreens and Florists' Supplies
15 Province St. and 9 Chapman Place,
BOSTON, MASS.

SAMUEL A. WOODROW
WHOLESALE PLANTSMAN
Palms, Large and Small Ferns, etc.
53 West 30th Street, NEW YORK
Telephone 2083 Madison

WILLIAM H. KUEBLER
Brooklyn's Foremost and Best
WHOLESALE COMMISSION HOUSE
A First Class Market for all CUT FLOWERS
28 Willoughby St., Brooklyn, N. Y.
Tel. 4591 Maio

GLEARY'S HORTICULTURAL CO.
Management AMBROSE T. GLEARY
Wholesale Contracting, Jobbing, Auction
HORTICULTURAL PRODUCTS
of every description.
Consignments Received. Surplus Stock Converted.
62 Vesey St., NEW YORK

Moore, Hentz & Nash,
Wholesale Commission Florists,
55 and 57 West 26th Street,
Telephone No. 756
Madison Square. **New York.**

WHOLESALE FLOWER MARKETS. — PER 100. — TO DEALERS ONLY.

	CINCINNATI March 24	DETROIT March 23	BUFFALO March 23	PITTSBURG March 23
ROSES				
Am. Beauty, Fan, and Sp.....	25.00 to 35.00	25.00 to 35.00	20.00 to 30.00	20.00 to 30.00
“ Extra	15.00 to 25.00	15.00 to 25.00	15.00 to 25.00	15.00 to 20.00
“ No. 1	10.00 to 15.00	10.00 to 15.00	8.00 to 10.00	10.00 to 15.00
“ Lower grades.....	4.00 to 8.00	4.00 to 8.00	3.00 to 8.00	4.00 to 8.00
Bride, 'Maid, F. & S.....	8.00 to 10.00	8.00 to 10.00 to 10.00 to 8.00
“ Extra	6.00 to 8.00	6.00 to 8.00 to 6.00	5.00 to 6.00
“ Low. gr.....	3.00 to 4.00	3.00 to 4.00	3.00 to 4.00 to 4.00
Killarney, Richmond, Fan. & Sp.....	8.00 to 10.00	6.00 to 10.00 to 10.00	8.00 to 10.00
“ Lower grades.....	4.00 to 6.00	3.00 to 4.00	3.00 to 4.00	6.00 to 6.00
Chateaux, Wellesley, Fan. & Sp.....	6.00 to 8.00	6.00 to 10.00 to 15.00	8.00 to 10.00
“ Lower grades.....	4.00 to 5.00	2.00 to 4.00	7.00 to 10.00	4.00 to 6.00
Golden Gate, Ivory.....	4.00 to 6.00	3.00 to 4.00	3.00 to 4.00	4.00 to 8.00
CARNATIONS				
Fancy and Novelties..... to 3.00	2.00 to 3.00	2.00 to 3.00	2.00 to 3.00
Ordinary.....	1.00 to 2.00	1.00 to 1.50	1.00 to 2.00	1.00 to 1.50
MISCELLANEOUS				
Violets.....	.50 to .75	.75 to 1.00	.40 to .75	.25 to .75
Cattleyas.....	40.00 to 50.00	35.00 to 50.00	40.00 to 60.00 to 75.00
Cypripediums..... to to to to
Lilies.....	10.00 to 12.00	12.50 to 15.00	4.00 to 15.00	8.00 to 12.50
Lily of the Valley.....	3.00 to 4.00	2.00 to 4.00	2.00 to 4.00	1.00 to 2.00
Daisies..... to to to to
Daffodils.....	2.00 to 3.00	2.00 to 3.00	2.00 to 3.00	2.00 to 3.00
Tulips.....	2.00 to 4.00	2.00 to 3.00	2.00 to 3.00	2.00 to 4.00
Mignonette.....	6.00 to 8.00	4.00 to 8.00	2.00 to 5.00	2.00 to 4.00
Gardenias.....	35.00 to 50.00	35.00 to 50.00	35.00 to 50.00 to
Lilac per bunch..... to 1.50 to 1.50	.50 to 1.00	.50 to 1.00
Sweet Peas.....	.50 to 1.00	.50 to 1.50	.40 to 1.00	1.00 to 1.25
Adiantum..... to 1.00	.75 to 1.20	.50 to 1.00 to
Whitmanii Floods..... to to to to
Smilax.....	12.00 to 15.00	10.00 to 15.00 to 15.00	12.50 to 15.00
Asparagus Plumosus, strigs.....	40.00 to 50.00	35.00 to 50.00	40.00 to 60.00	35.00 to 50.00
“ “ & Sprea. (100 bchs.)	25.00 to 35.00 to 30.00	25.00 to 50.00	35.00 to 50.00

H. C. BERNING
Wholesale Florist
1402 Pine Street, ST. LOUIS, MO.

A. MOLTZ
Will purchase flowers on order in
N. Y. market and ship carefully at
prevailing wholesale prices. Address
55-57 West 26th Street, New York City

MILLANG BROS.
WHOLESALE COMMISSION FLORISTS
41 West 28th Street
Telephone 3860
Madison **NEW YORK**

REED & KELLER
122 West 25th St., New York
Florists' Supplies
We manufacture all our
Metal Designs, Baskets, Wire Work & Novelties
and are dealers in
Glassware Decorative Greens and Florists' Requisites.

In writing to Advertisers kindly mention Horticulture

Buyer's Directory and Ready Reference Guide

Advertisements under this head, one cent a word. Initials count as words.

Regular advertisers in this issue are also listed under this classification without charge. Reference to List of Advertisers will indicate the respective pages.

Buyers failing to find what they want in this list will confer a favor by writing us and we will try to put them in communication with reliable dealers.

ACCOUNTANT

R. J. Dysart, 28 State St., Boston.
For page see List of Advertisers.

ALTERNANTHERAS

Red Alternantheras at 40 cents per 100.
C. W. Moeckel, 17 Summer St., Fitchburg, Mass.

AQUARIUMS

Aquarium plants the year round. Wholesale and retail. Send for price list. Schmid's Emporium of Pets, 712 12th Street, Washington, D. C.

ARAUCARIAS

Godfrey Aschman, 1012 Ontario St., Philadelphia, Pa.
For page see List of Advertisers.

ASPARAGUS

A. N. Pierson, Cromwell, Conn.
Asparagus Plumosus Seedlings.
For page see List of Advertisers.

Asparagus plumosus and Sprengerii, 2-in., strong, \$2.00 per 100. J. H. Dann & Son, Westfield, N. Y.

Asparagus Plumosa, 2 in. pots. Fine plants, \$3.00 per 100; \$25.00 per 1000. Cash with order or good reference. Erie Floral Co., Erie, Pa.; or, Wm. F. Kastig Co., 385 Elliott St., Buffalo, N. Y.

ASTERS.

Charles A. Kibbe, Elmhurst, Ill.
Aster Lady Roosevelt.

AUCTION SALES

Cleary's Horticultural Co., 62 Vesey St., New York.
Horticultural Products of Every Description.

For page see List of Advertisers.

The Fruit Auction Co., 200-204 Franklin St., New York.
Auction Sales of Plants, Etc.

ASTER SEEDS.—All Full Weight Packets Fertile 1907 Crop. EXPRESS.—White, Violet, Rose. Trade Packet 1-16 oz., 25c.; 1-4 oz., 75c.; ounce, \$2.50. QUEEN OF MARKET.—White, Lt. Pink, Rose, Lavender, Purple. Trade Packet 1-8 oz., 10c.; 1-4 oz., 15c.; ounce, 50c. LATE BRANCHING.—White, Pink, Rose, Lavender, Purple. Trade Packet 1-8 oz., 29c.; 1-4 oz., 30c.; ounce, 89c. CARLSON'S BRANCHING.—Pink, Lavender, Early and Late White. Trade Pkt. 1-8 oz., 25c.; 1-4 oz., 40c.; ounce, \$1.25. KATE LOCK.—White, Daybreak. Same price as Branching. ROYAL PURPLE.—Trade Pkt. 1-16 oz., 35c.; 1-4 oz., \$1.00; ounce, \$3.00. VIOLET KING.—Trade Pkt. 1-8 oz., 30c.; 1-4 oz., 50c.; ounce, \$1.50.

Many Other Standard Sorts in Limited Quantity. Write if interested.
ELMER D. SMITH & CO., Adrian, Mich.

AZALEAS

A. Leuthy & Co., Perkins St. Nurseries, Roslindale, Mass.

For page see List of Advertisers.

W. W. Edgar Co., Waverley, Mass.
For page see List of Advertisers.

August Rolker & Sons, New York, 31 Barclay St., or P. O. Box 752.
For page see List of Advertisers.

BAMBOO CANES

Stump & Walter Co., 50 Barclay St., New York.

For page see List of Advertisers.

Yokohama Nursery Co., 31 Barclay Street, New York.

For page see List of Advertisers.

BAY TREES.

N. F. McCarthy & Co., 84 Hawley St., Boston.

For page see List of Advertisers.

Bay Trees and Box Trees, standards and pyramids. All sizes. Price list on application. J. Roehrs Co., Rutherford, N. J.

BEDDING PLANTS

R. Vincent, Jr., & Sons Co., White Marsh, Maryland.

For page see List of Advertisers.

Carlman Ribsam, 31 Wall St., Trenton, N. J.

For page see List of Advertisers.

BEGONIAS

10,000 Begonia Vernon, 2 in., 2c. M. Fenton, West Newton, Pa.

Begonia Pres. Carnot, 2 1/2 in., \$3.00 100. Valley Greenhouse Co., Sewickley, Pa.

BOILERS

BOILERS. "Burnham" Boilers made for greenhouse heating. Lord & Burnham, 1133 Broadway, N. Y.

BOXWOOD

Henry M. Robinson & Co., 15 Provlace St., Boston.

For page see List of Advertisers.

BUILDING MATERIAL

BUILDING MATERIAL of all description for All Cypress, Semi-Iron, Iron Frame or Truss Houses. Hot Bed Sash and Frames. Lord & Burnham Co., 1133 Broadway, N. Y.

BULBS AND TUBERS

Joseph Breck & Sons, 47-54 N. Market St., Boston.

For page see List of Advertisers.

J. M. Thornburn & Co., 33 Barclay St., New York.

For page see List of Advertisers.

A. T. Boddington, 342 W. 14th St., N. Y.

For page see List of Advertisers.

Rickards Bros., 37 East 19th St., New York.

For page see List of Advertisers.

H. F. Mitchell Co., Philadelphia.

For page see List of Advertisers.

H. E. Fiske Seed Co., Faneuil Hall Sq., Boston.

For page see List of Advertisers.

James Vick's Sons, Rochester, N. Y.

For page see List of Advertisers.

D. Kusconl, 123 W. Sixth St., Cincinnati, O.

For page see List of Advertisers.

Aug. Rolker & Sons, 31 Barclay St., New York.

For page see List of Advertisers.

Seasonable Import Plants and Bulbs.

For page see List of Advertisers.

K. Velthuys, Hillegom, Holland, represented by Felix Bosch, 260 Clarendon St., Boston.

Bulbs French and Dutch.

For page see List of Advertisers.

Ralph M. Ward & Co., 2 W. Broadway, New York, Agts. for Martial Bremond, Ollioules, France.

For page see List of Advertisers.

Stump & Walter Co., 50 Barclay St., New York.

For page see List of Advertisers.

CANNAS

The Conard & Jones Co., West Grove, Pa.
For page see List of Advertisers.

J. B. Shurtleff & Son, Cushman Ave., Revere, Mass.

Live Cannas Started from Sand.

For page see List of Advertisers.

Cannas: 6 varieties at \$1.00 per 100; 7 varieties at \$1.25 per 100; 10 varieties at \$1.50 per 100. Our new Dark Pink seedling W. E. Cottrell, the best pink yet, 25c. each; \$2.50 per doz. Frank Cummings Bulb & Plant Co., Meridian, Miss.

Cannas: Dormant roots, Chas. Henderson, Coronet, Allemania, America, Anstria, Burbank, Grand Rouge, Partenope, Prea. Carnot. Pres. Favre, D. J. Sisley, L. Patry, Robusta, T. S. Ware, \$1.20 per 100. Mixed colors \$1.00. 10 per cent of 1000 lots. Cash with order. All popular varieties. Low contract prices for next season. Largest canna farms in U. S. Vick's Branching Aster seed, white, 50c. oz. Salvia Bonfire, \$2.00 oz. All Borists' seeds at fair prices. Binghamton Seed Co., Binghamton, N. Y.

CARNATIONS

F. Dorner & Sons Co., Lafayette, Ind.
For page see List of Advertisers.

S. S. Skidelsky, 1741 N. 18th St., Philadelphia.

For page see List of Advertisers.

Chicago Carnation Co., Joliet, Ill.

For page see List of Advertisers.

John E. Hahnes, Bethlehem, Pa.
Carnations Imperial and Pink Imperial.
For page see List of Advertisers.

Chas. H. Totty, Madison, N. J.

For page see List of Advertisers.

A. N. Pierson, Cromwell, Conn.

For page see List of Advertisers.

H. A. Jahn, New Bedford, Mass.

Carnation Lloyd.

White Enchantress, unrooted cuttings. Write for prices. Won first prize for best vase of 50. F. H. Westhoff, De Haven, Pa.

Carnation cuttings of all the leading varieties at the same price as any reliable firm. Write for prices before you look elsewhere. Wm. F. Kastig Co., 383 Elliott St., Buffalo, N. Y.

CHRYSANTHEMUMS

Chas. H. Totty, Madison, N. J.

Single Chrysanthemums.

For page see List of Advertisers.

A. N. Pierson, Cromwell, Conn.

For page see List of Advertisers.

Chrysanthemums. 5000 unrooted cuttings of Yellow Bonnaffon, 70c. per 100. F. H. Westhoff, De Haven, Pa.

Will have 100,000 rooted cuttings of the best 60 commercial varieties ready about March 25. Have your orders booked now. Postal will bring new price list. Satisfaction guaranteed. W. Ehmman, Corfu, N. Y.

Chrysanthemums ready: 2 1/2 inch strong stock of Tonsel, Oct. Frost, Polly Rose, Wanamaker, and all standards, \$3 per 100, \$25 per M. New: 2 1/2 inch strong, Alice Roosevelt, Hankey, Clay Frick, Winter Cheer, Rosette, B. May, \$5 per 100, \$40 per M. Cash. Send for catalog. Harlowarden Greenhouses, Greenport, N. Y.

COLEUS

Coleus cuttings, 60c. 100; 2 in., 2c. mixed. M. Fenton, West Newton, Pa.

Coleus Golden Bedder, Verschaffeltii, 2 in., \$2.00 100; rooted cuttings, 60c. 100. Valley Greenhouse Co., Sewickley, Pa.

For List of Advertisers See Page 429

CONIFERS

John Waterer & Sons, Ltd., American Nursery, Bagshot, Eng.
For page see List of Advertisers.
New England Nurseries, Bedford, Mass.
For page see List of Advertisers.

CUT FLOWER BOXES.

Edwards Folding Box Co., Philadelphia.
For page see List of Advertisers.
Folding cut flower boxes, the best made. Write for list. Holton & Hunkel Co., Milwaukee, Wis.

DAHLIAS

David Herbert & Son, Atco, N. J.
For page see List of Advertisers.
J. L. Moore, Northboro, Mass.
For page see List of Advertisers.
Wm. F. Turner & Co., New Bedford, Mass.
Ruth Forbes and Newport.
For page see List of Advertisers.
15,000 Field-grown clumps 2c. and up. List ready. H. W. Koerner, Sta. B, Milwaukee, Wis.
Dahlias: About 2000 Cath. Duer, Kreimhilde, Brunhilde, Snowlad, etc., \$3 per 100. Cash. Harlowarden Greenhouses, Greenport, N. Y.
Dahlias. Novelties and standard varieties, true to name, a choice list of the best introductions. Send for catalogue of dahlias, hollyhocks, hardy plants, etc. W. W. Wilmore, Box 382, Denver, Colo.
Dahlia Roots—Undivided field clumps, Lyndhurst, Maid of Kent, William Agnew, White Swan, Kreimhilde, John Walker, Arbella and A. D. Livoni. Write for low prices. Wood & Healey, Hammonton, New Jersey.
Cactus, Decorative, Show, Fancy and Pompon Dahlias. 75 leading varieties to select from. Strong divided clumps, in 10 or 20 varieties, my selection at \$3.00 per 100; \$25.00 per 1000. Single Dahlias, mixed, \$1.00 per 100. Cash with order please. Hermann Thiemann, Monson, Mass.

DECORATIVE PLANTS

A. Leuthy & Co., Perkins St. Nurseries, Roslindale, Mass.
For page see List of Advertisers.

EASTER PLANTS

Wm. W. Edgar Co., Waverley, Mass.
For page see List of Advertisers.
A. Leuthy & Co., Perkins St. Nurseries, Roslindale, Mass.
For page see List of Advertisers.

ENGLISH WALL FLOWERS

Henry A. Dreer, 714 Chestnut St., Philadelphia, Pa.
For page see List of Advertisers.

EUONYMUS RADICANS

Euonymus radicans, 1-1 1/2 ft., \$6.00; 2-2 1/2 ft., \$8.00 per 100. Bushy plants. Brae-Burn Nursery, West Newton, Mass.

EVERGREENS

The New England Nurseries, Bedford, Mass.
For page see List of Advertisers.

FERNS

A. Leuthy & Co., Roslindale, Mass.
For page see List of Advertisers.
H. H. Barrows & Son, Whitman, Mass Nephrolepis Whitman.
For page see List of Advertisers.
Godfrey Aschmann, 1012 Ontario St., Philadelphia, Pa.
For page see List of Advertisers.
John Scott, Brooklyn, N. Y.
For page see List of Advertisers.
Baur Floral Co., Erie, Pa.
For page see List of Advertisers.

Nephrolepis Exaltata Bostoniensis, fine young plants, \$10.00 per 1000.
N. Elegantiissima, young plants \$15.00 per 1000. Send for price list. Soar Bros, Little River, Fla.

FERTILIZERS

Pulverized Manure Co., 31 Union Stock Yards, Chicago, Ill.
Wizard Brand Cattle Manure.
For page see List of Advertisers.
Thos. J. Grey & Co.,
32 and 33 South Market St., Boston.
High-Grade Scotch Soot.
For page see List of Advertisers.

FLORAL PHOTOGRAPHS

Floral Photographs. Foley's 226-228 1/2 Bowery, New York.

FLORISTS' LETTERS.

Boston Florist Letter Co., 66 Pearl St., Boston, Mass.
For page see List of Advertisers.
Koral Mfg. Co., 26 Hawley St., Boston.
For page see List of Advertisers.

FLORISTS SUPPLIES

N. F. McCarthy & Co., 84 Hawley St., Boston.
For page see List of Advertisers.
H. M. Robinson & Co., 15 Province St. and 9 Chapman Pl., Boston, Mass.
For page see List of Advertisers.
The Keivan Co., 113 W. 25th St., N. Y. Decorative Evergreens.
For page see List of Advertisers.
Reed & Keller, 122 W. 25th St., New York.
For page see List of Advertisers.
J. B. Muidoch & Co., 714 Penn Ave., Pittsburg, Pa.
For page see List of Advertisers.
H. Bayersdorfer & Co., 1129 Arch St., Philadelphia.
For page see List of Advertisers.
Alex. Mann, Jr., Co., 1125 Polk St., San Francisco, Calif.
For page see List of Advertisers.

FLOWERS BY TELEGRAPH

Park Floral Co., Denver, Colo.
For page see List of Advertisers.
J. N. Champlin & Co., 1026 Chapel St., New Haven, Conn.
For page see List of Advertisers.
George H. Cooke, Washington, D. C.
For page see List of Advertisers.
Gude Bros. Co., 1214 F St., Washington, D. C.
For page see List of Advertisers.
Atlanta Floral Co., Atlanta, Ga.
For page see List of Advertisers.
M. C. & J. E. Hauswirth, 232 Michigan Ave., Chicago.
For page see List of Advertisers.
William J. Smyth, Michigan Ave. and 31st St., Chicago.
For page see List of Advertisers.
Jacob Schulz, 644 4th Ave., Louisville, Ky.
For page see List of Advertisers.
Thos F. Galvin, 124 Tremont St., Boston.
For page see List of Advertisers.
Julius A. Zinn, 2 Beacon St., Boston.
For page see List of Advertisers.
Houghton & Clark, 396 Boylston St., Boston.
For page see List of Advertisers.
Sidney Hoffman, 59-61 Massachusetts Ave., Boston.
For page see List of Advertisers.
Edward MacMullin, 194 Boylston St., Boston.
For page see List of Advertisers.
J. Breitmeyer's Sons, Miami and Gratiot Aves., Detroit, Mich.
For page see List of Advertisers.
Samuel Murray, 1017 Broadway, Kansas City, Mo.
For page see List of Advertisers.
Wm. L. Rock Flower Co., 1116 Walnut St., Kansas City, Mo.
For page see List of Advertisers.
Fred C. Weber, 4326-28 Olive St., St. Louis, Mo.
For page see List of Advertisers.
H. G. Eyres, 11 N. Pearl St., Albany, N.Y.
For page see List of Advertisers.
David Clarke's Sons, 2159-2141 Broadway, New York.
For page see List of Advertisers.
W. H. Donohoe, 17 E. 28th St., New York.
For page see List of Advertisers.

FLOWERS BY TELEGRAPH—

Continued

Alex. McConnell, New York.
For page see List of Advertisers.
M. A. Bowe, 1294 Broadway, New York.
For page see List of Advertisers.
Robert G. Wilson, Fulton St. & Greene Av., Brooklyn, N. Y.
For page see List of Advertisers.
Thomas Young, Jr., 500 Fifth Ave., N. Y.
For page see List of Advertisers.
Young & Nugent, 42 W. 25th St., N. Y.
For page see List of Advertisers.

FLOWER POTS

W. H. Ernest, 25th and M Sts., Washington, D. C.
For page see List of Advertisers.
A. H. Hews & Co., Cambridge, Mass.
For page see List of Advertisers.
Hilfinger Bros., Ft. Edward, N. Y.
For page see List of Advertisers.
Red pots, seed pans, etc.
The Peters & Reed Pottery Co., Zanesville, O.
Paper pots for all early vegetables. Two inch pots \$1.00 a thousand; three inch \$1.25; four inch \$1.60. P. B. Crosby, Catonsville, Md.

FUCHSIAS

Fuchsias, finest mixed, 2 in., \$2.50 per 100; rooted cuttings, \$1.00. Valley Greenhouse Co., Sewickley, Pa.

GALAX

Michigan Cut Flower Co., 38 and 40 Broadway, Detroit, Mich.
For page see List of Advertisers.

GERANIUMS

R. Vincent Jr. & Sons Co., White Marsh, Md.
New and Standard Varieties.
For page see List of Advertisers.
Geraniums, 2-in., double red, \$2.00 per 100. J. H. Dunn & Son, Westfield, N. Y.
500 Nutt Geranium Cuttings, \$1.50 per 100, or the lot for \$6.50. C. W. Moekkel, 17 Summer St., Fitchburg, Mass.
Geranium Mme. Sallerol, strong 2 in., ready for 3 in., \$2.00 per 100. Cash. Ellis Brothers & Company, Keene, N. H.
Geraniums, Nutt, Castellaine, La Favorite, XX fine, healthy, 2-in. stock, cool grown, not spindled, \$2.00 100, \$17.50 1000. Cash. F. C. Greene, 610 Innis St., Oil City, Pa.

GLADIOLI

Arthur Cowee, Meadowvale Farm, Berlin, New York.
For page see List of Advertisers.
J. L. Moore, Northboro, Mass.
For page see List of Advertisers.
I. & J. L. Leonard, Iona, N. J.
Gladiolus Bulbs.
For page see List of Advertisers.
Gladioli. Write for leaflet. B. Hammond Tracy, Cedar Acres, Wenham, Mass.
Gladioli. Named varieties and mixtures. Send for list. E. E. Stewart, Rives Junction, Mich.

GLASS

Boston Plate & Window Glass Co., Boston.
For page see List of Advertisers.
Standard Plate Glass Co., 26-30 Sudbury St., Boston.
For page see List of Advertisers.
S. Jacobs & Sons, 1365-79 Flushing Ave., Brooklyn, N. Y.
For page see List of Advertisers.
Metropolitan Material Co., 1398-1408 Metropolitan Ave., Brooklyn, N. Y.
For page see List of Advertisers.
Parshelsky Bros., 59 Montrose Ave., Brooklyn, N. Y.
For page see List of Advertisers.
Foley Mfg. Co., between Western Ave. and 26th St., Chicago, Ill.
Greenhouse glass, lowest prices. Johnston Glass Co., Hartford City, Ind.
GLASS, High Grade, Double Thick Greenhouse Glass. Lord & Burnham, 1133 Broadway, N. Y.

In writing to Advertisers kindly mention Horticulture

GLAZING POINT

H. A. Dreer, Philadelphia, Pa.
For page see List of Advertisers.

GLAZING POINTS, Lord & Burnham
Special Glazing Nalla (Points), Lord &
Burnham, 1133 Broadway, N. Y.

GRAPE DUST

Hammoud's Paint & Slug Shot Works,
Fishkill-on-Hudson, N. Y.
For page see List of Advertisers.

GREENHOUSE BUILDING MATERIAL.

Lord & Burnham Co.,
1133 Broadway, New York.

For page see List of Advertisers.

Plerion U-Bar Co., 1 Madison Sq., N. Y.
For page see List of Advertisers.

A. T. Stearns Lumber Co., Neponset,
Boston.

For page see List of Advertisers.

King Construction Co., N. Tonawanda,
New York.

For page see List of Advertisers.

J. C. Montinger Co., 117 East Blackhawk St.,
Chicago, Ill.

For page see List of Advertisers.

Foley Mfg. Co., between Western Ave. and
26th St., Chicago, Ill.

For page see List of Advertisers.

I. Cassidy, Summer Ave. and Erie R. R.,
Newark, N. J.

For page see List of Advertisers.

W. H. Lutton, Jersey City, N. J.
For page see List of Advertisers.

Geo. B. Deane, 18 Midway St., Boston.
Iron Pipe.

For page see List of Advertisers.

Metropolitan Material Co., 1398-1408 Metro
politan Ave., Brooklyn, N. Y.

For page see List of Advertisers.

S. Jacobs & Sons, 1365-79 Flushing Ave.,
Brooklyn, N. Y.

GREENHOUSE CONSTRUCTION

GREENHOUSE CONSTRUCTION, Semi-
Iron Greenhouse, New Truss Houses and
Iron Frame Houses, Lord & Burnham,
1133 Broadway, N. Y.

J. A. Payne, 260-274 Culver Ave., Jersey
City, N. J.

For page see List of Advertisers.

I. Cassidy, Summer Ave. and Erie R. R.,
Newark, N. J.

For page see List of Advertisers.

Foley Mfg. Co., between Western Ave. and
26th St., Chicago, Ill.

For page see List of Advertisers.

W. H. Lutton, Jersey City, N. J.
For page see List of Advertisers.

GREENHOUSE HOSE

Mineralized Rubber Co., 18 Cliff St., N. Y.
For page see List of Advertisers.

GUTTERS

GUTTERS, Cast Iron Gutters, L. & R.
Improved V Shaped Gutter with drip gut
ter attachment, Lord & Burnham, 1133
Broadway, N. Y.

HAIL INSURANCE

Florists' Hall Asso. of America.
J. G. Esler, Saddle River, N. J.
For page see List of Advertisers.

HARDY FERNS AND SUPPLIES

H. M. Robinson & Co., 15 Proville St.
and 9 Chapman Pl., Boston, Mass.

For page see List of Advertisers.

The Kervan Co., 112 W. 28th St., N. Y.
For page see List of Advertisers.

Michigan Cut Flower Exchange,
38 and 40 Broadway, Detroit, Mich.

Fancy Ferns.
For page see List of Advertisers.

H. J. Smith, Hinsdale, Mass.
For page see List of Advertisers.

HARDY PLANTS

Lobelia cardinalis, large clumps, \$1.50
per doz., \$8.00 per 100. Gentiana Andrewsii
and linearis, in clumps, \$1.50 per doz., \$8.00
per 100. Native ferns, trees and shrubs at
prices to suit. A fine lot of nursery grown
White Pine, Hemlock, Fir Balsam, Norway
and White Spruce of various sizes at re-
duced prices. L. E. Williams, Nottingham,
N. H.

HART'S HANDY HANDLE

Geo. B. Hart, 24 Stone St., Rochester, N. Y.
For page see List of Advertisers.

HEATING APPARATUS

Lord & Burnham Co.,
1133 Broadway, New York.

For page see List of Advertisers.

Plerion U-Bar Co., 1 Madison Sq., N. Y.
For page see List of Advertisers.

John A. Payne, 260-274 Culver Ave., Jersey
City, N. J.

For page see List of Advertisers.

HELIOTROPES.

Heliotropes, 2 in., \$2.50 100; rooted cut-
tings, \$1.00 100. Valley Greenhouse Co.,
Sewickley, Pa.

HELP FURNISHED

Thos. H. Bambrick, 34 S. 7th St., Phila.
For page see List of Advertisers.

HERBACEOUS PERENNIALS

Red Oak Nurseries, Flskeville, R. I.
For page see List of Advertisers.

HOLLYHOCKS

Hollyhocks, separate colors, field grown,
healthy stock, \$3.00 per 100; also Dahlias,
novelties and standard varieties. Send for
catalogue. W. W. Wilmore, Box 382, Den-
ver, Colo.

HOSE

Frank L. Moore, Chatham, N. J.
Sunnyside Hose.

For page see List of Advertisers.

HOT-BED MATS

G. H. Frost, W. Newton, Mass.
For page see List of Advertisers.

HOT-BED SASH

The A. T. Stearns Lumber Co., Neponset,
Mass.

For page see List of Advertisers.

Plerion U-Bar Co., 1 Madison Sq., N. Y.
For page see List of Advertisers.

Lord & Burnham Co., 1133 Broadway, N. Y.
For page see List of Advertisers.

Foley Mfg. Co., between Western Ave. and
26th St., Chicago, Ill.

HYDRANGEAS.

HYDRANGEAS PANICULATA.
Grandiflora, 18-in. to 24-in., \$5.00 per 100.
Grandiflora, 2 ft. to 3 ft., \$7.00 per 100.
Grandiflora, 3 ft., \$8.00 per 100.
J. H. Dann & Son, Westfield, N. Y.

INSECTICIDES.

Nicotinide kills all greenhouse pests
P. R. Paethcorpe Co.,
Eleventh St., Owensboro, Ky.

For page see List of Advertisers.

Wm. Elliott & Sons, 201 Fulton St.,
New York.

Target Brand Insecticides.

For page see List of Advertisers.

IRISES

Japanese Iris, 25 choicest varieties, large,
well rooted divisions, \$10 per 100. Yucca
filamentosa, \$15 per 100. T. H. Chivers,
Amesbury, Mass.

Iris pallida dalmatica, a beautiful shade
of lavender; the largest and most beauti-
ful of all the German Irises; perfectly
hardy, and free flowering. One of the good
things almost lost to horticulture. \$12.00
per 100; \$100.00 per 1,000. Cash with or-
der. J. A. Peterson, McHenry Ave., West-
wood, Cincinnati, O.

JAPANA CUT FLOWER HOLDER

M. V. Garnsey, 130 Walola Ave.,
La Grange, Ill. Dept. M.

For page see List of Advertisers.

KENTIAS

A. Lenthy & Co., Roslindale, Mass.

For page see List of Advertisers.

Godfrey Aschmann, 1012 W. Ontario St.,
Philadelphia.

For page see List of Advertisers.

LEADING RETAIL FLORISTS

Park Floral Co., Denver, Colo.
For page see List of Advertisers.

George H. Cooke, Washington, D. C.

For page see List of Advertisers.

Gude Bros. Co., 1214 F St.,
Washington, D. C.

For page see List of Advertisers.

Atlanta Floral Co., Atlanta, Ga.

For page see List of Advertisers.

M. C. & J. E. Hauswirth, 232 Michigan Ave.,
Chicago.

For page see List of Advertisers.

William J. Smyth, Michigan Ave. and 31st
St., Chicago.

For page see List of Advertisers.

Jacob Schniz, 644 4th Ave., Louisville, Ky.
For page see List of Advertisers.

Thos. F. Galvin, 124 Tremont St., Boston.
For page see List of Advertisers.

Julius A. Zinn, 2 Beacon St., Boston.

For page see List of Advertisers.

Houghton & Clark, 396 Boylston St.,
Boston.

For page see List of Advertisers.

Sidney Hoffman, 59-61 Massachusetts Ave.,
Boston.

For page see List of Advertisers.

Edward MacMulkin, 194 Boylston St.,
Boston.

For page see List of Advertisers.

J. Breitmeyer's Sons, Detroit, Mich.

For page see List of Advertisers.

Samuel Murray, 1017 Broadway,
Kansas City, Mo.

For page see List of Advertisers.

Wm. L. Rock Flower Co., 1118 Walnut
St., Kansas City, Mo.

For page see List of Advertisers.

Fred C. Weber, 4326 Olive St., St. Louis,
Mo.

For page see List of Advertisers.

J. N. Champlin & Co., 1026 Chapel St.,
New Haven, Conn.

For page see List of Advertisers.

H. G. Eyres, 11 N. Pearl St., Albany, N. Y.
For page see List of Advertisers.

David Clarke's Sons, 2139-2141 Broadway,
New York.

For page see List of Advertisers.

W. G. Donohoe, 17 E. 28th St., New York.
For page see List of Advertisers.

Alex. McConnell, New York.

For page see List of Advertisers.

M. A. Bove, 1294 Broadway, New York.
For page see List of Advertisers.

Robert G. Wilson, Fulton St. and Greene
Ave., Brooklyn, N. Y.

For page see List of Advertisers.

Thomas Young, Jr., 500 Fifth Ave., N. Y.
For page see List of Advertisers.

Young & Nugent, 42 W. 28th St., N. Y.
For page see List of Advertisers.

For page see List of Advertisers.

MISCELLANEOUS PLANTS.

Colons, 10 varieties, 2-in., 1 1-2c. Nastur-
tiums, double red and yellow, 2-in., 1 1-2c.;
rooted cuttings, 75c. Gnaphalium, rooted
cuttings, 75c. 100. Tradescantia tricolor,
rooted cuttings, 75c. Guzmania, rooted
cuttings, 75c. Geraniums, 2-in. Trego,
Vland, Buchner, Heranderon, \$2 100. Saller-
rol, 2-in., \$1.50. J. F. Sked, Westerville,
Ohio.

NEW AND RARE PLANTS

Rose Hill Nurseries, New Rochelle, N. Y.
For page see List of Advertisers.

MISSION PLANT BOX

Wagner Park Conservatories, Sidney, O.
For page see List of Advertisers.

NICO-FUME

Kentucky Tobacco Product Co.,
Louisville, Ky.

For page see List of Advertisers.

NURSERY STOCK

John Waterer & Sons, Ltd.,
American Nursery, Bagshot, England.

For page see List of Advertisers.

New England Nurseries, Bedford, Mass.
Shrubs, Roses and Herbaceous Perennials.

Speelmeo Pyramidal Box.

For page see List of Advertisers.

For List of Advertisers See Page 429

NURSERY STOCK — Continued

Bay State Nurseries, N. Abington, Mass.
Herbaceous Perennials, Hardy Ornamental Trees.

For page see List of Advertisers.

Clery's Horticultural Co., 62 Vesey St., New York.

For page see List of Advertisers.

P. Ouwerkerk, 216 Jane St., Weehawken Heights, N. J.

Holland Nursery Stock for Forcing.

For page see List of Advertisers.

American Nursery Co., 150 Broadway, New York, N. Y.

For page see List of Advertisers.

I. & J. L. Leonard, Iona, N. J.
California Privet, American Chestnuts.

For page see List of Advertisers.

D. J. Twomey, Dept. H., Geneva, N. Y.
Trees and Plants.

For page see List of Advertisers.

Carlman Ribsam, 31 Wall St., Trenton, N. J.

California Privet, Trees, Shrubs, Etc.

For page see List of Advertisers.

The Morris Nursery Co., Sales Office, 1 Madison Ave., New York.

Ornamental Trees, Evergreens, Hedge Plants.

For page see List of Advertisers.

Peter's Nursery Co., Knoxville, Tenn.
Live Fences; Amoor and California Privet.

For page see List of Advertisers.

NURSERY STOCK.

	Per 100
2,500 Berberis Thunbergii, 2 to 3 ft.	\$9.00
1,000 Cornus Spathul, golden, 1 1/2 to 2 ft.	10.00
1,000 Cydonia Japonica, 2 1/2 to 3 ft.	9.00
500 Dentzia Pride of Rochester	10.00
500 Forsythia in 3 varieties	10.00
500 Hydrangea Pan. grand.	10.00
10,000 Ligustrum Itoha, 2 1/2 to 3 ft.	8.00
1,000 Crimson Ramblers, 2 yrs.	9.00 & 10.00
1,000 Dorothy Perkins, 2 yrs.	9.00 & 10.00
Rhododendrons, Azaleas, etc.	
The Continental Nurseries, Franklin, Mass.	

ORCHID PLANTS

Lager & Hurrell, Summit, N. J.
For page see List of Advertisers.

Sander, St. Albans, England.
Importers, Exporters, Growers, Hybridists

For page see List of Advertisers.

Julius Roehrs Co., Rutherford, N. J.
For page see List of Advertisers.

Carrillo & Baldwin, Secaucus, N. J.
For page see List of Advertisers.

Jos. A. Madda, 191 Valley Road, W. Orange, N. J.

For page see List of Advertisers.

Ordouez Bros., Madison, N. J., Box 105.
For page see List of Advertisers.

PALMS

A. Leuthy & Co., Perkins St. Nurseries, Roselindale, Mass.

For page see List of Advertisers.

Robert Craig Co., Market and 49th Sts., Philadelphia, Pa.

For page see List of Advertisers.

Kentia, Phoenix, etc., all sizes. Write for new price list. Julius Roehrs Co., Rutherford, N. J.

PAINT AND PUTTY

PAINT AND PUTTY: Ideal Greenhouse lead; Special Greenhouse Putty. Lord & Burnham, 1133 Broadway, N. Y.

PANSY PLANTS.

Choice pansy plants, 50c. per 100; \$4.00 per 1000. Cash. Aug. Zirngelbel, Needham, Mass.

PATENTS

Siggers & Siggers, Washington, D. C.
For page see List of Advertisers.

PEAT

Orchid peat, Rotted peat, Azslea peat, Leaf-Mould, Live Sphagnum moss, Baled Sphagnum moss, Green Clump moss, etc. Jobbers' list on application. C. W. Brownell & Co., Walden, N. Y.

PELARGONIUMS

R. Vincent, Jr. & Sons Co., White Marsh, Maryland.

For page see List of Advertisers.

PEONIES

Wholesale Peony list for fall 1908 is now ready. J. F. Rosenfield, West Point, Neb.

One of the finest collections in America. Send 25 cts. in stamps for new edition of Peony Manual. C. S. Harrison's Select Nursery, York, Neb.

PHLOXES

Send 25 cts. in stamps for Phlox Manual. Fine mixed phloxes \$1.50 per 100. C. S. Harrison's Select Nursery, York, Neb.

PIPE AND FITTINGS

Foley Mfg. Co., between Western Ave. and 26th St., Chicago, Ill.

Eagle Metal & Supply Co., Johnson and Union Aves., Brooklyn, N. Y.

Second-Hand Pipe and Roller Tubes.
For page see List of Advertisers.

PIPE AND FITTINGS. Cast Iron and Wrought Pipe, Valves, Elbows, Pipe Hooks, Automatic Air Headers, etc. Lord & Burnham, 1133 Broadway, N. Y.

PLANT BED CLOTH

Mineralized Rubber Co., 18 Cliff St., N. Y.
For page see List of Advertisers.

PLANT STAKES AND TRELLISES

Seele's Patent, for roses, chrysanthemums, gladioli, tuberose, dahlias, tomatoes, egg plants, etc. H. D. Seele & Sons, Mfg., Elkhart, Ind.

POT HANGERS

Pot hangers, Kramer's \$1 doz. by exp. \$1.25 by mail. I. N. Kramer & Son, Cedar Rapids, Ia.

RAFFIA

Raffia (colored), 20 beautiful shades. Samples free. H. H. Comey Co., Camden, N. J.; 810 Washburn Ave., Chicago, Ill.

RHODODENDRONS

John Waterer & Sons, Ltd., American Nursery, Bagshot, England.
For page see List of Advertisers.

P. Ouwerkerk, Hoboken, N. J.
For page see List of Advertisers.

Harlan P. Kelsey, Salem, Mass.
American Hardy Rhododendrons.

ROSES

Julius Roehrs Co., Rutherford, N. J.
Rambler Rose, Newport Fairy.
For page see List of Advertisers.

New England Nurseries, Inc., Bedford, Mass.

For page see List of Advertisers.

Bay State Nurseries, N. Abington, Mass.
For page see List of Advertisers.

Ellwanger & Barry, Rochester, N. Y.
Hardy Roses.

For page see List of Advertisers.

Robert Craig Co., Market and 49th Sts., Philadelphia, Pa.

For page see List of Advertisers.

Dingee-Conard Co., West Grove, Pa.
New Climbing Rose, Tausendschon.
For page see List of Advertisers.

The Morris Nursery Co., Sales Office, 1 Madison Ave., New York.

Ornamental Trees, Evergreens, Hedge Plants.

For page see List of Advertisers.

M. H. Walsh, Woods Hole, Mass.
Roses that Bloom from June to November.
For page see List of Advertisers.

Montrose Greenhouses, Montrose, Mass.
Grafted Stock Bride, Bridesmaid, Killarney.

For page see List of Advertisers.

F. R. Pierson Co., Tarrytown-on-Hudson, N. Y.

Hardy Roses for the Garden.
For page see List of Advertisers.

400 varieties; own roots; summer grown. Leedle Company, Springfield, Ohio.

Roses, Maid, Bride, Chateaux, Gate, 2 lb., \$3.00 100. Valley Greenhouse Co., Sewickley, Pa.

Crimson Ramblers, 2 year, on own roots, extra strong, at 7 cents. Gilbert Costich, Rochester, N. Y.

Low-budded roses, No. 1, \$95.00; No. 11-2, \$65.00 1000. H. T. Jones, Elizabeth, N. J.

SAGE PLANTS

Good thrifty sage plants from 2 inch pots, \$1.50 per 100; ready now. Cash with order. Virginia Nursery Co., Purcellville, Va.

SEEDS

T. J. Grey Co., 32 So. Market St., Boston, Mass.

For page see List of Advertisers.

Joseph Breck & Sons, 51 and 52 N. Market St., Boston, Mass.

For page see List of Advertisers.

W. Atlee Burpee & Co., Philadelphia.
For page see List of Advertisers.

J. M. Thorburn & Co., 33 Barclay St., N. Y.
For page see List of Advertisers.

A. T. Boddington, 342 W. 14th St., N. Y.
For page see List of Advertisers.

H. F. Mitchell Co., 1017 Market St., Phila.
For page see List of Advertisers.

James Vick's Sons, Rochester, N. Y.
Vick's Superb Pansy Seed.
For page see List of Advertisers.

Hjalmar Hartmann & Co., 12 Stormgade, Copenhagen, Denmark.
Cauliflower and Cabbage Seed.
For page see List of Advertisers.

Rickards Bros., 37 E. 19th St., New York.
For page see List of Advertisers.

R. & J. Farquhar & Co., 6-7 So. Market St., Boston.

Glant Cyclamen Seed.
For page see List of Advertisers.

C. C. Morse & Co., 48-56 Jackson St., San Francisco, Cal.

For page see List of Advertisers.

H. E. Fiske Seed Co., Faneuil Hall Sq., Boston.

Aster Seed.
For page see List of Advertisers.

Braslan Seed Growers Co., San Jose, Cal.
For page see List of Advertisers.

O. V. Zangen, Hoboken, N. J.
For page see List of Advertisers.

Stump & Walter Co., 50 Barclay St., New York.

For page see List of Advertisers.

Weeber & Don, 114 Chambers St., New York.

For page see List of Advertisers.

Altimo Culture Co., Canfield, O.
Aster Seed.

For page see List of Advertisers.

Asparagus Pl. Nanus, \$2.50 per 1000. Plant early. Asparagus Plants 14 to 18 inches high, \$6 per 100. Peter Mack, Box 172, Orlando, Fla.

Davis Perfect and Burrell's Klondike Cucumber Seed, Sac. per pound. Finest slicing varieties grown. D. V. Burrell, Rocky Ford, Colorado.

SEEDS SEEDS

Buckbee's Famous "Fall of Life" Pedigreed Strains of the newest and best varieties vegetable and flower seeds, etc. If you have failed to receive a copy of our Spring Trade List write for it today.

H. W. BUCKBEE, Rockford, Illinois. Rockford Seed Farms. Forest City Greenhouses.

SMILAX

E. A. Beaven, Evergreen, Ala.
Southern Wild Smilax; Log Mosses.
For page see List of Advertisers.

Vern L. Schluraff, Erie, Pa.
For page see List of Advertisers.

Smilax, nice young plants, fall sown, 50c. per 100; \$4.00 per 1000. F. A. Baller, Bloomington, Ill.

SPHAGNUM MOSS

Live Sphagnum moss, orchid peat and orchid baskets always on hand. Lager & Hurrell, Summit, N. J.

Fresh, clean, 5 bbl. bale, \$1.25; 2 bales, \$2.25; 5 bales, \$5.00; 10 bales, \$9.50. Cash. H. R. Akers, Chatsworth, N. J.

For a high grade Sphagnum and Green Decorating Moss, different grades of Peat, write for prices and samples. We can give best satisfaction as our stock is well cleaned, well packed. Prompt attention given. American Moss & Peat Co., Box 6, Waretown, N. J.

SQUABS

Jno. A. Kepner, Harrisburg, Pa., Box 3.
For page see List of Advertisers.

In writing to Advertisers kindly mention Horticulture

STRAWBERRY PLANTS

M. Crawford Co., Cuyahoga Falls, O.
New Strawberry, The Highland.
For page see List of Advertisers.

STEAM TRAP

E. Hppard, Youngstown, O.
For page see List of Advertisers.

TOBACCO SOAP

Henry A. Dreer, 711 Chestnut St., Philadelphia, Pa.

VENTILATING APPARATUS

Pierson U-Bar Co., 1 Madison Sq., N. Y.
For page see List of Advertisers.

Foley Mfg. Co., between Western Ave. and
26th St., Chicago, Ill.
For page see List of Advertisers.

John A. Payne, 260-274 Culver Ave., Jersey
City, N. J.
For page see List of Advertisers.

VENTILATING MACHINERY. New
Model enclosed, self-rolling gear; Standard
Model Open Gear. Lord & Burnham, 1133
Broadway, N. Y.

VERBENAS

Verbena Seedlings, grown from Burpee's
finest seed, \$1.00 per 100; ready to send
April 25. Cal. Violets, plants from open
ground, \$1.50 per 100. Gardenia Florida,
unrooted cuttings, 50c. per 100. John C.
Shins, St. Marks, Ga. Money orders pay-
able at Hazansville, Ga.

VIOLETS

William Sim, Cliffdale, Mass.
Violet Boston.
For page see List of Advertisers.

Violet cuttings, "Marla Louisa" Rhine-
beck stock, rooted runners, May delivery
\$20.00 M. Immediate delivery, between
now and March 15th, \$10.00 M. Wm. F.
Kastling Co., 383 Ellicott St., Buffalo, N. Y.

WEEKLY BOARD FILE

A. F. Lewis Mfg. Co., E. Boston, Mass.
For page see List of Advertisers.

WIREWORK

Reed & Keller, 122 W. 25th St., N. Y.
For page see List of Advertisers.

Wirework. Write for our catalogue.
Holtan & Hunkel Co., Milwaukee, Wis.

William E. Heilscher's Wire Works, 38-40
Broadway, Detroit, Mich.

The "Just Right" kind. Send for price
list. Frank W. Ball, 31 East Third Street,
Cincinnati, O.

WOOD MOSS

D. Ruseoni, 128 W. 6th St., Cincinnati, O.
For page see List of Advertisers.

WHOLESALE FLORISTS**Boston**

N. F. McCarthy & Co., 84 Hawley St.,
Boston.
For page see List of Advertisers.

H. M. Robinson & Co., 15 Province St.
and 9 Chapman Pl., Boston.
For page see List of Advertisers.

Welch Bros., 226 Devonshire St., Boston.
For page see List of Advertisers.

Buffalo

Wm. F. Kastling Co., 383-87 Ellicott St.,
Buffalo, N. Y.
For page see List of Advertisers.

Chicago

Chas. W. McKellar, 51 Wabash Ave.,
Chicago.
For page see List of Advertisers.

Peter Reinberg, 51 Wabash Ave., Chicago.
For page see List of Advertisers.

E. F. Winterson Co., 45-49 Wabash Ave.,
Chicago.
For page see List of Advertisers.

Detroit

Michigan Cut Flower Exchange, 38 and 40
Broadway, Detroit, Mich.
For page see List of Advertisers.

WHOLESALE FLORISTS—**Continued
Minneapolis**

Rice Bros., 115 N. 6th St., Minneapolis,
Minn.
For page see List of Advertisers.

New York

J. K. Allen, 106 W. 28th St., New York
For page see List of Advertisers.

J. S. Fenrich, 110 W. 28th St., New York.
For page see List of Advertisers.

Ford Bros., 48 W. 28th St., New York
For page see List of Advertisers.

H. E. Froment, 57 W. 28th St., New York
For page see List of Advertisers.

Alex. J. Guttman, 43 W. 28th St., New
York.
For page see List of Advertisers.

E. C. Horan, 55 W. 28th St., New York
For page see List of Advertisers.

A. H. Langjahr, 55 W. 28th St., New York
For page see List of Advertisers.

James McManus, 42 W. 28th St., New York
For page see List of Advertisers.

John I. Raynor, 49 W. 28th St., New York.
For page see List of Advertisers.

W. F. Sheridan, 39 W. 28th St., New York
For page see List of Advertisers.

Traendly & Schenck, 44 W. 28th St., New
York.
For page see List of Advertisers.

John Young, 51 W. 28th St., New York
For page see List of Advertisers.

Moore, Hentz & Nash, 55 and 57 W. 26th
St., New York.

Frank S. Hicks & Co., 52 W. 28th St.,
New York.
For page see List of Advertisers.

Frank Millang, 57 W. 26th St., New York
For page see List of Advertisers.

Wm. H. Kuebler, 28 Willoughby St.,
Brooklyn, N. Y.
For page see List of Advertisers.

Phillip F. Kessler, 55 and 57 W. 26th St.,
New York.
For page see List of Advertisers.

A. Moltz, 55-57 W. 26th St., New York.
For page see List of Advertisers.

B. S. Slinn, Jr., 55 W. 26th St., New York.
For page see List of Advertisers.

Millang Bros., 41 W. 28th St., New York.
For page see List of Advertisers.

Philadelphia

W. E. McKisslek, 1619-1621 Ranstead St.,
Philadelphia, Pa.
For page see List of Advertisers.

Leo Nissen Co., 1209 Arch St., Philadel-
phia, Pa.
For page see List of Advertisers.

The S. S. Pennock-Meehan Co., 1608-18
Ludlow St., Philadelphia, Pa.
For page see List of Advertisers.

Edward Reid, 1526 Ranstead St., Phila-
delphia, Pa.
For page see List of Advertisers.

Pittsburg

J. B. Murdoch & Co., 714 Penn Ave., Pitts-
burgh, Pa.
For page see List of Advertisers.

San Francisco

Alex. Mann, Jr., Co., 1125 Polk St., San
Francisco, Cal.
For page see List of Advertisers.

St. Louis

H. G. Berning, 1402 Pine St., St. Louis, Mo.
For page see List of Advertisers.

WHOLESALE PLANTSMAN

Samuel A. Woodrow, 53 W. 30th St.,
New York.
For page see List of Advertisers.

New Offers in This Issue.**BIOTA AUREA NANA.**

P. J. Berckmans Co., Fruitland Nurseries,
Augusta, Ga.
For page see List of Advertisers.

**EASTER PLANTS: LILIES, AZA-
LEAS.**

Godfrey Aschmann, 1012 W. Ontario St.,
Philadelphia.
For page see List of Advertisers.

**FORDHOOK BUSH LIMA BEANS:
FORDHOOK MUSK MELONS.**

W. Atlee Burpee & Co., Philadelphia.
For page see List of Advertisers.

LILIUM AURATUM.

V. H. Hallock & Son, Queens, N. Y.
For page see List of Advertisers.

PEERLESS PLANT FOOD.

Henry A. Dreer, 714 Chestnut St., Phila-
delphia.
For page see List of Advertisers.

ROSES.

R. & J. Farquhar & Co.,
6 and 7 South Market Street, Boston.
For page see List of Advertisers.

**SHRUBS, ROSES, SMALL FRUITS,
ORNAMENTAL AND FRUIT
TREES.**

L. L. May & Co., St. Paul, Minn.
For page see List of Advertisers.

SPRAYERS.

Charles J. Jager Co., 281-85 Franklin St.,
Boston.
For page see List of Advertisers.

VENTILATING APPARATUS.

The Advance Co., Richmond, Ind.
For page see List of Advertisers.

**VENTILATING APPARATUS:
GREENHOUSE CONSTRUCTION.**

Foley Mfg. Co., Western Av., bet. 25th &
26th Sts., Chicago.
For page see List of Advertisers.

VINCAS.

J. J. Arnold, Homer, N. Y.
For page see List of Advertisers.

Anything of Value

to the profession

CAN BE SOLD

through advertising in

Horticulture

List of Advertisers

Advance, The Co.410	Page	Lord & Burnham Co.432	Page
Allen J. K.422		Lutton W. H.431	
Altin Culture Co.475		Manda Jos.416	
American Nursery413		Man, Alex Jr. Co.420	
American Nursery Co.413		MacMullin E. A.419	
Arnold J. J.411		May L. L. & Co.411	
Aschmann G.398-411		McCarthy N. F. & Co.423	
Atlanta Floral Co.419		McConnell Alex.410	
Bambrick Thos. H.420		McKellar Charles W.420	
Barrows H. H. & Son.410		McKissick, W. E.420	
Baur Floral Co.416		McManus Jas.422	
Bayersdorfer H. & Co.420		Metropolitan Ma- terial Co.427	
Bay State Nurseries.413		Michell H. F. Co.414	
Beaven E. A.420		Nichigan Cut Flower Exchange.423	
Berkman, P. J. Co., Inc.411		Millang Bros.423	
Bernine H. G.423		Millang Frank.423	
Boddington A. T.415		Mineralized Rubber Co.430	
Boston Florist Letter Co.419		Moltz, A.423	
Boston Plate and Win- dow Glass Co.430		Moninger J. C.431	
Bosch, Felix.398		Montrose Green- houses.413	
Bowe, M. A.418		Moore Frank L.430	
Braslan Seed Growers Co.415		Moore, Hentz & Nash.423	
Breck Joseph & Sons.415		Moore, J. L.417	
Breitmeyer's J. Sons.418		Morris Nursery Co.411	
Bremond Martal.416		Morse C. C. & Co.415	
Bridgeman's Seed Warehouse.415		Murdoch J. B. & Co.420	
Burpee W. A. & Co.410-415		Murray Samuel.418	
		New England Nur- series.413	
		Niessen Leo. Co.420	
Carrillo & Baldwin.416		Ordoez Bros.416	
Cassidy I.421		Ouwkerk P.413	
Castle Co.432		Palethorpe P. R. Co.412	
Champion J. N. & Co.419		Park Floral Co.418	
Chicago Caranoo Co.417		Parselsky Bros.430	
Clarke's David, Sons.418		Payne John A.430	
Clary's Horticultural Co.423		Pennock-Meehan Co.420	
Conard & Jones Co.398		Perkins St Nurseries.398	
Cooke G. H.418		Peter's Nursery Co.413	
Cowee A.398		Pierson, A. N.398	
Craig, Robt. Co.416		Pierson F. R. Co.399	
Crawford M. & Co.411		Pierson U Bar Co.432	
		Pulverized Manure Co.412	
Dingee & Conard Co.413		Raynor John L.422	
Doane Geo. B. & Son.431		Red Oak Nurseries.398	
Doanhoe W. H.420		Reed & Keller.420	
Dorner F. Sons & Co.417		Reid Edw.420	
Dreer H. A.412-417-431		Reinberg Peter.423	
Dysart R. J.420		Ribsam Carlman.413	
Eagle Metal & Sup- ply Co.431		Rice Bros.420	
Edgar, W. W. Co.416		Rickards Bros.415	
Edwards Folding Box Co.420		Robinson H. M. & Co.422	
Elliott Wm. & Sons.414		Rock Wm. L. Flo. Co.418	
Ellwanger & Barry.414		Rochrs Julius Co.413-416	
Elmsford Nurseries.417		Rolker August & Sons398-430	
Esler J. C.430		Rose Hill Nurseries.398	
Ernest W. H.430		Rusconi D.416	
Eyres.418		Sander & Son.416	
Farquhar R. & J. Co.411-415		Schulz Jacob.418	
Fenrich J. S.422		Schlurff Vern L.421	
Fiske, H. E. Seed Co.415		Scott Bros.417	
Foley Mfg. Co.431		Scott, John.416	
Ford Bros.422		Sheridan W. F.422	
Fromeur H. E.422		Shurtleff J. B. & Son.398	
Fruitland Nurseries.411		Siggers & Siggers.436	
Galvin Thos. F.419		Sim, Wm.410	
Garnsey M. V.419		Situations & Wants.429	
Grey T. J. Co.415		Skidelsky S. S.417	
Gude Bros. Co.418		Slinn B. S. Jr.428	
Guttman Alex. J.422		Smith H. J.418	
		Smyth Wm J.428	
Haerens A.368		Standard Plate Glass Co.430	
Hail Asso.430		Stearns A. T. Lumber Co.430	
Haines, J. E.417		Stumpp & Walter Co.308-415	
Hallock V. H. & Sons, 417		Thorburn J. M. & Co.415	
Hammond Paint & Slug Shot Works.412		Totty Chas. H.419	
Hart, Geo. B.419		Traendlv & Schenck.422	
Hartmann Hjalmar & Co.415		Turner W. F. & Co.417	
Hauswirth M. C. & J. E.418		Twomey D. J.414	
Herbert David & Son.417		Valentine, J. A.418	
Hews A. H. & Co.430		Velthuis K.398	
Hicks Frank S. & Co.423		Vick's Jas. Sons.415	
Hilfinger Bros.430		Vincent R. Ir. & Sons.398	
Hibbard E.431		Walsh M. H.399	
Hoffman.419		Wagner Park Conser- vatories.419	
Horan E. C.422		Ward R. M. & Co.416	
Houghton & Clark.419		Waterer John & Sons.413	
Jager, Chas. J. Co.412		Weher F. C.418	
Kasting W. F.423		Weeber & Don.415	
Kentucky Tobacco Product Co.412		Welch Bros.420	
Kepper J. A.411		Wilson.418	
Kervan Co., The.421		Winterson, E. F. Co.420	
Kessler, P. F.422		Woodrow, Sam'l A.423	
King Cons. Co.431		Yokohama Nursery Co.416	
Koral Mfg. Co.411		Young John.422	
Kramer Bros Fdy. Co.420		Young, Thos Jr.418	
Kuebler Wm H.423		Young & Nugent.418	
Lager & Hurrell.418		Zangen O. V.415	
Langjahr, Alfred H.422		Zinn J. A.419	
Leonard I. & J.398			
Leuthy A. & Co.398			
Lewis A. F. Mfg Co.419			

LIST OF PATENTS.

Issued March 10, 1908.

- 881,151. Cultivator. Victor M. Powers and Charles P. Powers, Sattley, Cal.
 - 881,243. Wheel Plow. William E. Johnson, Rock Island, Ill., assignor to Rock Island Plow Co., Rock Island, Ill., a corporation of Ill.
 - 881,340. Plow Stock. James A. Raiford, Columbus, Ga.
 - 881,341. Plow Fender. James A. Raiford, Columbus, Ga.
 - 881,379. Plowshare. John B. Crapo, Parker, Idaho.
 - 881,391. Plow. Jonathan W. Farrington, Alba, Texas.
 - 881,414. Harrow Attachment for Plows. Emil M. Kramer, Paxton, Ill.
 - 881,566. Weeder Attachment to Cultivators. Maryette Everingham, East Onondago, N. Y., executrix of Francis M. Everingham, deceased.
 - 881,641. Process of Treating Sugar Beets. Moritz Weinrich, Yonkers, N. Y., assignor of one-third to Carl Portius, Halle-on-the-Saale, Germany.
 - 881,778. Cultivator. Clarence R. Dean, Glen Elder, Kas.
- Issued March 17, 1908.
- 882,230. Fertilizer Distributer. Nicklas H. Bloom and Joseph H. Bloom, Nashua, Iowa.
 - 882,353. Plow Disc and the Like. Peter Speirs, Tullamarine, Victoria, Australia.
 - 882,370. Manure Spreader. Benj. M. Buehler, Odebolt, Iowa.

USEFUL BOOKS.

We can supply the following books, postpaid, at the prices listed:—

The Chrysanthemum. Herrington. Price, 50 cts.

How to Make Money Growing Violets. Saltford. Price, 25 cts.

Daffodils-Narcissus and How to Grow Them. A. M. Kirby. Price, \$1.10.

Commercial Violet Culture. Dr. B. T. Galloway. Price, \$1.50.

Water Gardening. Piger Bisset Price, \$2.50.

Lawns and How to Make Them. Leonard Barron. Price, \$1.10.

Roses and How to Grow Them. By Many Experts. Price, \$1.10.

The New Cyclopeda of American Horticulture. L. H. Bailey. Four volumes; \$20.00.

How to Make School Gardens. H. D. Hemenway. Price, \$1.10.

How to Make a Fruit Garden. S. W. Fletcher. Price, \$2.20.

How to Plan the Home Grounds. S. Parsons, Jr. Price, \$1.10.

Soils: How to Handle and Improve Them. S. W. Fletcher. Price, \$2.20.

The Art of Landscape Gardening, by H. Repton. Price \$3.20, postpaid.

Water Lilies and How to Grow Them. Henri Huss and H. S. Conard. Price, \$1.21.

A Plea for Hardy Plants. J. Wilkinson Elliot. Price, \$1.76.

How to Make a Flower Garden. Price, \$1.76. By Various Experts.

Ferns and How to Grow Them. G. A. Woolson. Price, \$1.21.

Chrysanthemum Manual. Smith. Price, 40 cts.

WANTS, FOR SALE, ETC.

Advertisements in this column one cent a word. Initials count as words. Cash with order. All correspondence addressed "care HORTICULTURE" should be sent to 11 Hamilton Place, Boston.

HELP WANTED

WANTED—SALESMAN

To Handle Good Side Line On Commission

One who calls on Florists, Seed Houses, Nurseries, Cemetery Superintendents, Monument Dealers, etc.

The Kramer Bros. Foundry Co.
DAYTON, OHIO

WANTED—A single man to work under foreman; one with some experience in growing high grade pot plants. State experience, references and wages expected. Address Nahant, care Horticulture.

WANTED—A good all around man for greenhouse work and one who has a good knowledge of palms, azaleas, etc. State experience and wages desired. Address Palau, care of HORTICULTURE.

SITUATIONS WANTED

GOOD MEN

When you need good men, skilled or unskilled, Write:

THOS. H. BAMBRICK

34 South 7th Street Philadelphia

Help of all kinds, including that for Florists, Nurserymen, Seedsmen and the Horticultural trade generally.

SITUATION WANTED in general greenhouse work; single, age 35, five years' experience, commercial. Address W. W., care HORTICULTURE.

FOR SALE

FOR SALE—Five acres of good land, three greenhouses of 6000 sq. feet glass, nearly new, 100 hothead sash, 5 room dwelling, in good town, at a bargain. Address John A. Miller, Gardener, Creston, Ia.

FOR SALE—A large consignment of 16x24 double thick American glass, A and B quality. For further information write Parselsky Brothers, 50 Montrose Avenue, Brooklyn, N. Y.

FOR RENT.

FOR RENT—Six greenhouses, three acres fine soil, for term of years. Cheap. Address William Harris, Arlington, N. J.

MISCELLANEOUS WANTS

TO LEASE OR RUN UNDER SHARES.

The owner of a small nursery and well stocked greenhouse and flower shop now doing business in Northampton, will make a liberal business offer based on lease or shares with an enterprising nurseryman and florist of training and experience. Apply to the Home Culture Clubs, Labor Exchange, Northampton, Mass.

GREENHOUSES BUILDING OR CONTEMPLATED.

Keokuk, Ia.—C. Sommer, one house.
 Westboro, Mass.—A. O. Tufts, one house.
 Connellsville, Pa.—R. Marshall, one house.
 Janesville, Wis.—C. G. Dwight, three houses.
 Danbury, Ct.—W. H. Tomlinson, additions.
 Long Branch, N. J.—Louis Slekler, one house.
 Morton Grove, Ill.—Poehlmann Bros., range of houses.
 Albany, N. Y.—Mrs. L. Glocchner, two houses, each 33x150.
 Elmhurst, Ill.—Windland & Klemel, four rose houses, each 27x200.
 Cleveland, O.—F. R. Williams Co., eight rose houses, each 25x300.
 Salem, Ore.—C. F. Reuf, two houses, 20x100, 30x100; propagating house, 6x100.

The magnificent avenue of trees, one of the finest private avenues in England, on the Norfolk estate of King Edward, was nearly destroyed in the terrible tempest of early March.

GLASS
Greenhouse and Hot Bed
 SIZES OUR SPECIALTY IMMENSE STOCK
Plate and Window Glass
 Write us for Our Prices.
PARSHELSKY BROS.
 59 Montrose Ave., BROOKLYN, N. Y.

SUNNYWOODS HOSE
 Used and recommended by
Sunnywoods Greenhouses
 See page 394 of March 21st HORTICULTURE

OR ADDRESS
FRANK L. MOORE
 CHATHAM, NEW JERSEY

ANCHOR GREENHOUSE HOSE
 WEARS WELL.
PLANT BED CLOTH
 Protects from Cold and Dampness.
MINERALIZED RUBBER CO.
 18 Cliff Street New York

GREENHOUSE GLASS

Cheaper Now Than For Years

We are taking contracts for next Spring delivery.

WRITE FOR OUR PRICES

STANDARD PLATE GLASS COMPANY

26-30, Sudbury St. 61-63 Portland St.
 BOSTON, MASS.

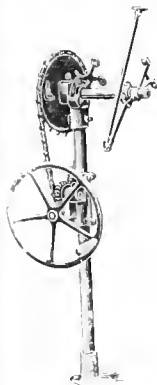

The Advance Ventilating Apparatus

has pleased all of our customers in the past. It is found in use in 38 states. Give us a chance to estimate on your needs and to tell you more about it. Free circulars and estimates.

The Advance Co.
 RICHMOND, IND.

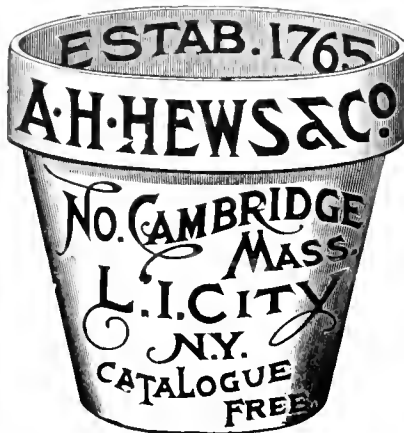

Standard Flower POTS

If your greenhouses are within 500 miles of the Capitol, write us, we can save you money

W. H. ERNEST

28th and M Street WASHINGTON D. C.

The **FLORISTS' HALL ASSOCIATION OF AMERICA**, insurer of 28,000,000 sq. ft. of glass. For particulars address John C. Esler, Sec'y, Saddle River, N. J.

JOHN A. PAYNE GREENHOUSE Designer & Builder

260-274 Culver Ave.
 JERSEY CITY, N. J.

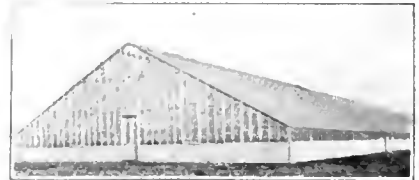

IRON FRAME SEMI-IRON FRAME TRUSS ROOF WOOD FRAME

Material Only or Erected
 Everything for the Greenhouse

CYPRESS SASH BARS 82 feet or longer
HOT BED SASH
PECKY CYPRESS BENCH LUMBER

GREENHOUSES

ERECTED AND EQUIPPED COMPLETE IF DESIRED

Write for Circular "D" and Prices

The A. T. STEARNS LUMBER CO.
 NEPONSET, BOSTON, MASS.

PATENTS

Trademarks and Copyrights

Send your business direct to Washington. Saves time and insures better service. Personal attention guaranteed. Twenty-five years' active service. SPECIALTY: "Working on the Failure of Others."

SIGGERS & SIGGERS

PATENT LAWYERS

Box 9, National Union Building
 Washington, D. C.

STANDARD FLOWER POTS

Packed in small crates, easy to handle.

Price per crate		Price per crate	
1500 2 in. pots in crate	\$4.88	120 7 in. pots in crate	\$4.20
1500 2 1/2 " " " "	5.25	60 8 " " " "	3.00
1500 3 " " " "	6.00	HAND MADE	
1000 3 " " " "	5.00	48 9 in. pots in crate	\$3.60
800 3 1/2 " " " "	5.80	48 10 " " " "	4.80
500 4 " " " "	4.50	24 11 " " " "	3.60
320 5 " " " "	4.50	24 12 " " " "	4.80
144 6 " " " "	3.16	12 14 " " " "	4.80
		6 16 " " " "	4.50

Seed pans, same price as pots. Send for price list of Cylinders for Cut flowers, Hanging Baskets, Lawn Vases, etc. Ten per cent. off for cash with order. Address **Hilfinger Bros., Pottery, Fort Edward, N. Y.** August Folker & Sons, Agts., 81 Barclay St., N. Y. City.

BOSTON PLATE & WINDOW GLASS COMPANY
GREENHOUSE GLASS --- German and American
 261 to 287 A Street BOSTON 20-22 Canal Street

WILLIAM H. LUTTON

HORTICULTURAL ARCHITECT AND BUILDER

WEST SIDE AVENUE STATION (C. R. R. OF N. J.)
JERSEY CITY, N. J.

Have not been established 50 years, but long enough to convince the wide-awake Florist and Gardener that it is to his interest to place his work in thoroughly practical hands.

(150,000 sq. ft. glass erected in 1907 will substantiate this claim)

And why not? My material is the best that can be secured. My iron frame construction has every modern feature that years of practical experience can embody.

AND THEN THERE IS THE COST TO BE CONSIDERED.

Why not let us take up this important question now?

IRON PIPE

SECOND HAND

WROUGHT IRON PIPE, for Steam, Water, Gas or Oil, Fences or Posts. All Sizes. Price Low.

GEO. B. DOANE & SON
18 Midway Street, BOSTON
Telephone, Main 4419

ISAAC CASSIDY

Summer Ave. & Erie R.R., Newark, N. J.

Write for Prices

**GREENHOUSE MATERIAL
CONSTRUCTION FITTINGS**
Bench Fittings

Material Furnished and Erected

R. TONAWANDA, N. Y.



GREENHOUSE CONSTRUCTION LUMBER

John C. Moninger Co.
117 E. Blackhawk St., CHICAGO

Holds Glass Firmly
See the Point  **PEERLESS**

FULL SIZE
N^o 2

Glazing Points are the best. No rights or lefts. Box of 1,000 points 75 cts. postpaid.
HENRY A. DEERL
114 Chestnut St., Philadelphia, Pa.

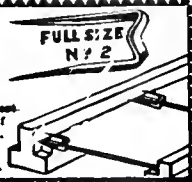

THE FOLEY MFG. CO.

CHICAGO

Completely equipped with up-to-date machinery for the making of material for

GREENHOUSE CONSTRUCTION

From a Full Supply of Thoroughly Seasoned Lumber

Send your sketches to our draughtsmen for completion and suggestion. Permit us to figure your proposed work, large or small.

We guarantee our prices will save you money

FOLEY VENTILATING APPARATUS IS THE BEST

Is Simple in Erecting. Is Easiest of Operation. It Will Last a Lifetime. Its Price is the Lowest. Will Ventilate Any Size House. Prices and Circulars on Application.

Our 1908 Catalogue Greenhouse Material Sent Postpaid on Request.

**THE FOLEY MFG. CO., WESTERN AVENUE
25th and 26th STS., CHICAGO**

THE STANDARD STEAM TRAP

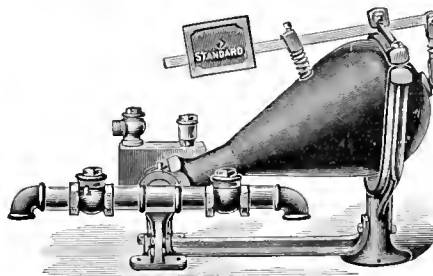

Is acknowledged the best for the florist, because it is durable and does its work without trouble and annoyance, saving its cost by the economy in coal bills.

E. HIPPARD
YOUNGSTOWN, OHIO

SECOND HAND PIPE & BOILER TUBES

Of all sizes, in good condition, suitable for steam purpose, coupled and threaded, for sale at low rates.

5000 feet 1 inch pipe, 3c. per ft.; 5000 feet 1 1/4 inch pipe, 4c. per ft.; 3000 feet 1 1/2 inch pipe, 5c. per ft.; 2000 feet 2 inch pipe, 6 1/2c. per ft.

EAGLE METAL & SUPPLY CO.,
Johnson and Union Aves., BROOKLYN, N. Y.

In ordering goods please add "I saw it in HORTICULTURE."

METROPOLITAN MATERIAL CO.

GREENHOUSE WRECKERS

GLASS Look at these prices. New American 50 ft. to the box, 10x12 single \$1.80 per box, 10x12, 12x12 B. double \$2.20 per box, 12x14, 12x20 and 14x14, 14x20 and 16x16, 10x18 B. double \$2.40 per box, 16x20, 16x24, 12x24 B. double \$2.50 per box. In lots of 10 boxes or more. Discount on large quantities. Let us quote you on

**CYPRESS MATERIAL HOTBED SASH
BOILERS PIPE FITTINGS
HOTBED FRAMES MATS**

1398-1408 METROPOLITAN AV., BROOKLYN, N. Y.

ROSE HOUSE

Carnation House
Plant House
Cucumber House

Any Kind of a House

Can be heated more evenly,
more economically and more
satisfactorily every way by the
use of the

Electric Circulator

For information as to what it is and
what it can do, address

CASTLE COMPANY

Heating Engineers

170 Summer Street, BOSTON, MASS.

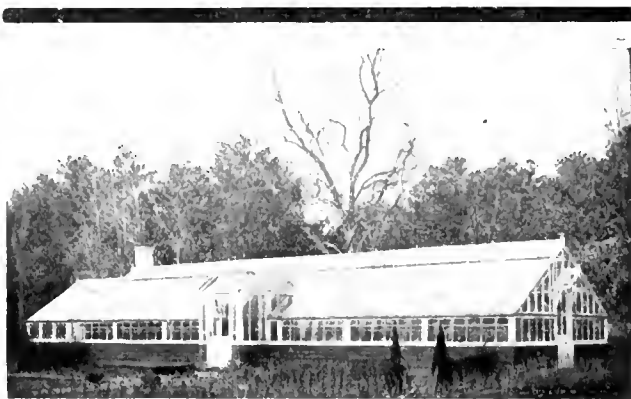

GREENHOUSE ENDURANCE

For out and out endurance — a house that will not only outlast any other, but is much the lightest — our Sectional Iron Frame Construction stands head and shoulders above others.

Gardeners and Superintendents, if you are interested in greenhouses for private places, parks, etc., send for new book — "Greenhouses as we build them."

WE MAKE EVERY PART OF A GREENHOUSE
BUT THE GLASS. WE SELL ANY PART.

LORD & BURNHAM CO.

MAIN SALES OFFICE:

1133 BROADWAY, NEW YORK

BOSTON: 810 Tremont Building
PHILADELPHIA: 1215 Filbert St.

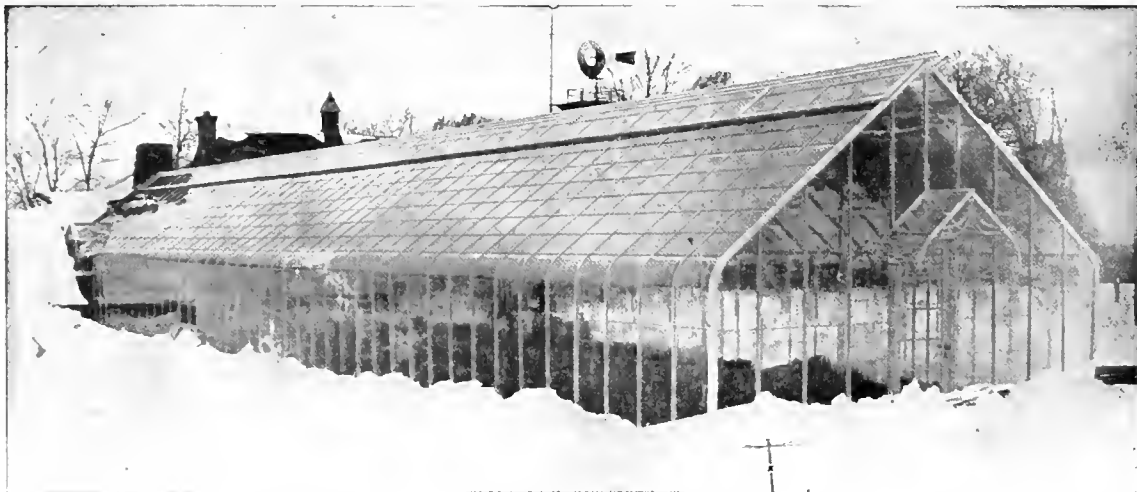

SNOW AND ICE FREE ROOFS

Right here is where you appreciate the tremendous advantage of the curved eave with neither plate nor gutter to hold back the snow or collect icicles. This photo was taken in Canada. The U-Bar greenhouse is entirely free, while a gutter constructed house at the rear is so completely snowed under that you cannot see it. We have recently replaced that house with a U-Bar. Send for catalog.

U-BAR GREENHOUSES

PIERSON

DESIGNERS AND BUILDERS



U-BAR CO.

1 MADISON AVE., NEW YORK

HORTICULTURE

Vol. VII.

APRIL 4, 1908

No. 14

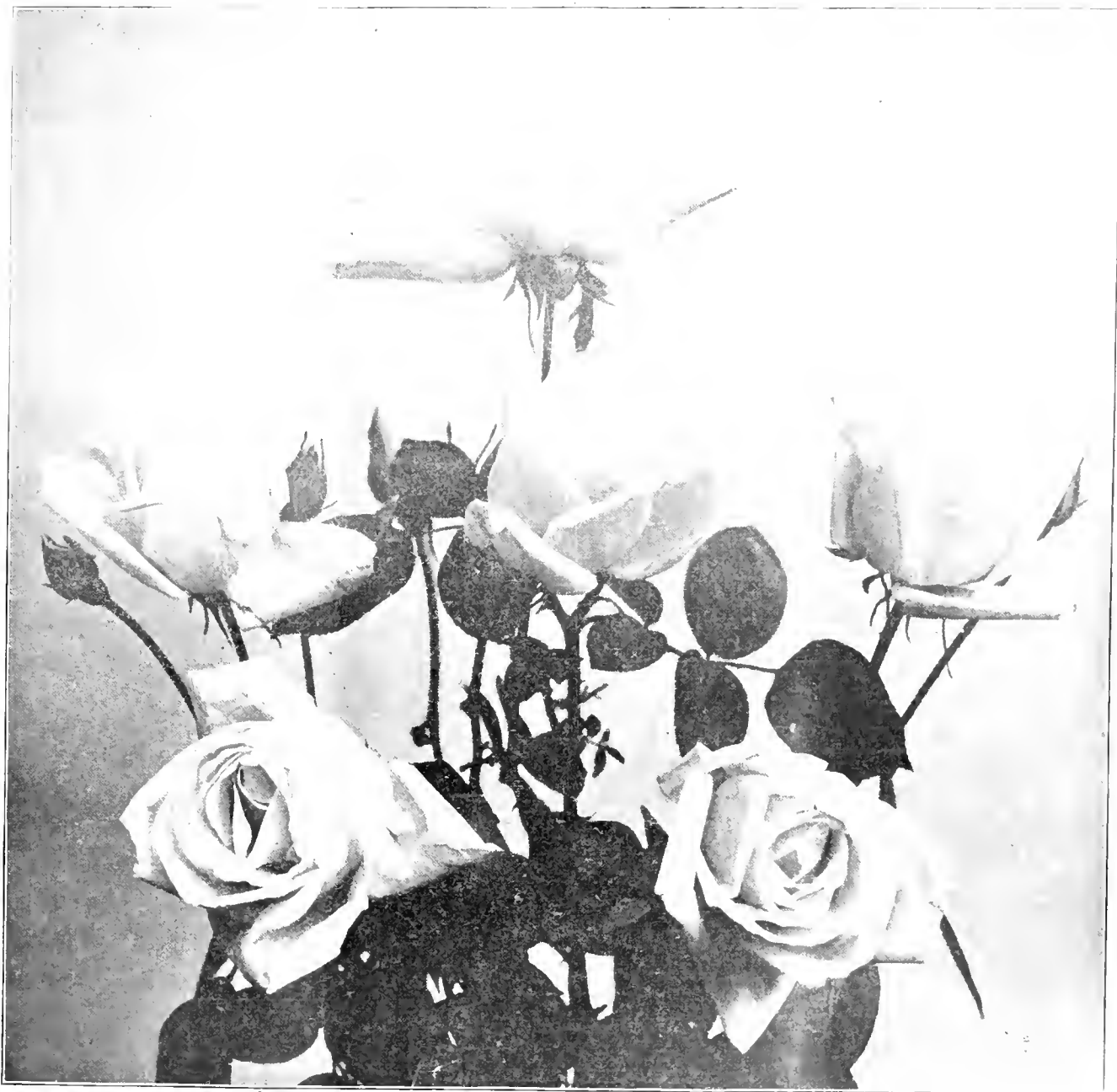

WHITE KILLARNEY

CANNA BULBS

Fine plump, Northern Grown, and in fine condition. Not to be compared with Southern grown stock, that are never thoroughly ripened and therefore are very slow to start growing.

	Doz.	100	1000		Doz.	100	1000
Allemania	\$0.35	\$2.50	\$22.50	Gladiator	\$0.40	\$3.00	\$27.00
Black Prince	.40	3.00	27.00	King Edward	.50	3.50	32.00
Black Warrior	.35	2.50	22.50	Louisiana	.55	4.00	35.00
Burbank	.30	2.25	20.00	Mad. Crozy	.40	3.00	27.00
Black Musafolia	.40	3.00	27.00	Mlle. Berat	.30	2.25	20.00
Charles Henderson	.35	2.50	22.50	Musafolia	.30	2.25	20.00
Director Roe'z	.35	2.50	22.50	Paul Marquant	.30	2.25	20.00
Flamingo	.30	2.25	20.00	Pres. McKinley	.35	2.50	22.50
Florence Vaughan	.35	2.50	22.50	Queen Charlotte	.35	2.50	22.50
Golden Star	.30	2.25	20.00	Robusta	.30	2.00	18.00
				Red Cross	.30	2.25	20.00

STUMPP & WALTER CO., 50 Barclay St., NEW YORK

GERANIUMS A splendid stock of fine plants in 2 inch pots, good standard sorts and new varieties at \$2.00 per 100 and up to \$1.00 each. We will send 1000 in 20 good varieties, our selection, for \$18.50. Our special descriptive **Geranium Catalogue**, describing over 250 varieties of Geraniums and Pelargoniums mailed free to the trade.

PELARGONIUMS In good variety, strong plants from 3 inch pots at \$1.50 per dozen, \$6.00 per 100

HARDY CHRYSANTHEMUMS Our collection of Hardy Chrysanthemums will compare favorably with any in the country and we have an immense stock ready for shipment. Small flowered or Button Varieties, \$2.00 per 100. Large Flowered or Aster Varieties, \$3.00 per 100. Description will be found in our Wholesale List.

DAHLIA ROOTS We still have about 75 varieties we can offer in Cactus, Decorative, Show and Pompon true to name at \$5.00 per 100 and up for Whole Field-grown clumps. One thousand, 50 each of 20 varieties, our selection, for \$40.00, all good kinds; a splendid collection for planting or just the thing for Store Trade.

	Per 100		Per 100
Alyssum, Giant Double	\$2.00	Hardy Flox	2.00
Ageratum, Stella Gurney	2 00	Hollyhocks, Strong 3 in. pot plants, dbl. white, pink, red and yellow	3.00
Begonia, Vernon, White and Rose	2 00	Ivy Leaved Geraniums, 6 good kinds, \$25.00 per 1000	3.00
" Gracilis, White and Rose	2 00	Lobelia, Crystal Palace Gem	2.00
Cuphaea, Cigar Plant	2.00	Lantanas, 5 varieties	2.00
Coleus, Verschaffeltii, Golden Bedder and other kinds	2.00	Lavender, 2 1/2 in. pots strong	3.00
Caladium, Esculentum, 1st size \$2.00 per 100; 2nd size	1.00	Panicum, Variegated, Handsome basket plants	2.00
Fuchsias, Black Prince and Minnesota-Lieutenant Muritz, White and Rose Phenomenal	2 50	Swainsona, Alba	2.00
Hardy English Ivy, Extra Strong, \$15.00 per 1000	2.00	Salvia Bonfire and Splendens	2.00
		Tradescantia, Dark Variegated	2.00
		Verbena, Red, White, Purple and Pink	2.00

R. VINCENT JR. & SONS COMPANY, White Marsh, Md.

YOU WANT THEM NOW

Before the cream of the varieties is all sold. The finest stock of standard

HARDY PERENNIALS

in the country. Write and we'll quote tempting prices.

Red Oak Nurseries, Fiskeville, R. I.

AZALEAS for fall delivery, the best that are grown, also **PALMS** for spring or fall delivery, furnished by Belgium; orders booked now.....

AUGUST ROLKER & SONS, 31 Barclay Street, or P. O. Box 752, New York

Decorative Plants

Azaleas, Kentias, Rubbers, Arecas, Araucarias, Pandanus, Box Trees, Euonymus, Crotons, and Eurya latifolia.

Extra good value in

EASTER PLANTS

Order Ahead.

A Leuthy & Co.

Perkins Street Nurseries, Roslindale, Mass.

Rose Hill Nurseries

New and Rare Plants

NEW ROCHELLE, N. Y.

New York Office, Siebrecht Building, 425 Fifth Avenue

ROBERT CRAIG CO.

ROSES, PALMS,

and Novelties in Decorative Plants

MARKET and 49th STREETS., PHILADELPHIA, PA.

COLEUS

Verschaffeltii, Golden Queen, Fire Brand, Lord Palmerston, Queen Victoria, Beckwith's Gem. Prices of Rooted Cuttings by express, 60c, per 100; \$5 per 1000. Less than 250 of a variety will be charged at the 100 rate.

Golden Bedder, Hero, Nessey, Pearl of Orange. 75c. per 100; \$6 per 1000. Less than 250 of a variety will be charged at the 100 rate.

Fancy Varieties. A very fine assortment of twelve kinds not listed above. 75c. per 100; \$6 per 1000. 250, in assortment, our selection, at the 1000 rate.

MISCELLANEOUS PLANTS

AGERATUM, Stella Gurney, Princess Pauline. SALVIA Splendens, Bonfire. HELIOTROPE. Rooted cuttings, 75c. per 100; \$6 per 1000.

CARNATIONS

Rooted Cuttings	100	1000
Winsor	\$6.00	\$50.00
White Perfection	2.50	20.00
Rose Pink Enchantress	3.50	30.00
Enchantress	2.50	20.00
Queen Louise	2.50	20.00

From 2 1/4 inch pots, add \$1.00 per 100.

ASPARAGUS PLUMOSUS NANUS SEEDLINGS From flats, \$1.00 per 1000.

CHRYSANTHEMUMS

Standard varieties, ready for shipment. Rooted cuttings, \$2 per 100; \$15 per 1000. Send for list.

A. N. PIERSON, CROMWELL, CONN.

GLADIOLI

I can satisfactorily supply your wants for Gladioli for forcing or outdoor planting. Mixtures, color sections or named varieties of exceptional beauty.

Write for Prices

ARTHUR COWEE

Gladiolus Specialist

Meadowvale Farm, BERLIN, N. Y.

GLADIOLUS BULBS

100,000, from 1 1/4 inches up @ \$1.00 per 1000
100,000, 3/4 to 1 1/4 inches @ \$2.00 per 1000
Cash with order. Description given on request.
Nice stock of California Privet. \$1.00 per 1000 and up, as to quality. Write for particulars.
Nice lot of American Chestnut Trees at a bargain. Thirty-five large Sugar trees, most of them sample trees.

I. & J. L. LEONARD, IONA, N. J.

HYACINTHS, TULIPS, NARCISSI AND OTHER BULBS

ROMAN HYACINTHS and the true PAPER WHITE GRANDIFLORA

Ask for our Wholesale Trade List at Hillegom

K. VELTHUYS, Hillegom, Holland
Rep. by FELIX BOSCH, 260 Clarendon St., Boston.

CANNAS

Send for our List and Prices

The CONARD & JONES CO. WEST GROVE, PA.

In ordering goods please add, "I saw it in HORTICULTURE."

LIVE CANNAS

Started from Sand at \$2.00 per 100
Austria, Robusta, Pennsylvania, Chas. Henderson, Italia, Pres. Carnot, Mlle. Berat, A. Bouvier, Duke of Marlborough.

J. B. SHURTLEFF & SON, Cushman Ave., Revere, Mass.

DREER DAHLIAS

We can still supply in undivided field-grown roots, varieties as listed below. All are desirable cut flower sorts.

	Per doz.	Per 100		Per doz.	Per 100
A. D. Livoni (Quilled), Pink.....	\$1.00	\$ 8.00	Grand Duke Alexis (Quilled), Ivory white.....	\$1.00	\$8.00
Aegir (Cactus), Cardinal red.....	1.00	8.00	Henry Patrick (Decorative), White.....	1.00	8.00
Alba Superba (Single), Fine large white.....	1.25	10.00	H. W. Silem (Cactus), Cardinal red.....	2.50	15.00
Arabella (Show), Light, sulphur-shaded peach.....	1.25	10.00	Parbor Light (Cactus), Brilliant cochineal red.....	2.50	15.00
Admiral Deby (Decorative), French Purple.....	1.00	8.00	Horn of Plenty (Cactus), Deep carmine purple.....	1.00	8.00
Amos Perry (Cactus), Free fiery red.....	2.50	15.00	J. H. Jackson (Cactus), Crimson maroon.....	1.25	10.00
Bon Ton (Show), Rich garnet.....	1.00	8.00	John Thorpe (Show), Solferino rose.....	1.25	10.00
Black Diamond (Decorative), Purplish garnet.....	1.00	8.00	Kriemhilde (Cactus), Pink.....	1.00	8.00
Blackbird (Single), Black velvety maroon.....	1.00	8.00	Landrath, Dr. Schiff (Cactus), Rosy apricot.....	1.00	8.00
Cham-leon (Fancy), Flesh, pink and yellow.....	1.25	10.00	Lenau (Cactus), Coral red and apricot.....	2.50	15.00
Cornucopia (Cactus), Vermillion carmine.....	1.00	8.00	Lyndhurst (Decorative), Bright red.....	1.00	8.00
Capstan (Cactus), Soft orange scarlet.....	1.00	8.00	Time Alfred Moreau (Show), Pink.....	1.25	10.00
Cuban Giant (Show), Large bright maroon.....	2.50	20.00	Mrs. Roosevelt (Giant), Pink.....	2.00	15.00
Catherine Duer (Decorative), Red.....	1.00	8.00	Maroon Century (Single), Rich velvety maroon.....	2.50	20.00
Clifford W. Bruton (Decorative), Yellow.....	1.00	8.00	Miss May Loomis (Show), White suffused rose.....	1.25	10.00
Crimson Century (Single), Crimson and rose.....	1.25	10.00	Queen Victoria (Quilled), Yellow.....	1.00	8.00
Duchess of Cambridge (Show), Pink tipped crimson.....	1.25	10.00	Queen of Yellows (Show), Yellow.....	1.25	10.00
Else (Cactus), Amber and rose.....	2.50	15.00	Ruckert (Cactus), Bright red.....	1.00	8.00
Emily (Show), Solferino rose.....	1.25	10.00	Red Hussar (Show), Cardinal red.....	1.25	10.00
Fire-rain (Decorative), Brilliant red.....	1.00	8.00	Reliable (Cactus), Carmine and salmon.....	2.50	15.00
Frank Smith (Fancy), Maroon tipped white.....	1.25	10.00	Ringdove (Cactus), Carmine with white edge.....	1.00	8.00
Frau Hermine Marx (Cactus), Silvery rose.....	2.50	15.00	Scarlet Century (Single), Scarlet.....	2.50	20.00
Frute (Cactus), Peach and cream.....	1.25	10.00	Shooting Star (Cactus), Golden Yellow.....	2.50	15.00
Flora (Cactus), Pure white.....	2.50	15.00	Souveni de Gustave Doazan (Giant), Pure scarlet.....	3.50	25.00
Floradora (Cactus), Blood red.....	1.25	10.00	Stard Bearer (Cactus), Fiery scarlet.....	1.25	10.00
Florence A. Stredwick (Cactus), White, fine form.....	1.25	10.00	Sylvia (Decorative), Soft pink.....	1.00	8.00
Fanny Purchase (Show), Yellow.....	1.25	10.00	Twentieth Century Single Pink.....	1.25	10.00
Gracie (Single), Delicate blush.....	1.00	8.00	Uncle Tom (Cactus), Deep maroon.....	1.00	8.00
Gen Buller (Cactus), Red, tipped white.....	1.00	8.00	Walthari (Cactus), Sulphur yellow, white edges.....	2.50	15.00
Gottelinde (Cactus), Yellow.....	1.00	8.00	One each of the fifty-nine varieties for \$50.00.		

HENRY A. DREER, 714 Chestnut Street, Philadelphia, Pa.

The above prices are for the trade only.

DAHLIAS

Novelties and Standard Varieties

Our Leaders—RUTH FORBES and NEWPORT
Send for free catalogue

WILLIAM F. TURNER & COMPANY
New Bedford - - - Mass.

DAHLIAS. Now is the time to place your order for bulbs which will insure you getting named varieties in any quantity; prompt delivery.

DAVID HERBERT & SON,
Successors to L. K. Peacock, Inc.
ATCO, N.J.

100,000 DAHLIAS

Premium Stock, guaranteed true to name.
500,000 large Flowering Gladioli, hundreds of colors and variations mixed. Wholesale prices on application. Order now for spring delivery. Catalogue free.
J. L. MOORE, Northboro, Mass.

In writing advertisers kindly mention HORTICULTURE.

VINGA Var. and Major FINE STOCK

Field-grown stock, potted into 4-inch and grown on. Ready for 5-inch now. 1st size, \$7.00; 2d, \$6.00 per 100. No cnls offered. Packed light. Cash with order.
J. J. ARNOLD, Homer, N.Y.

GRAFTED STOCK
BRIDE, BRIDESMAID and RICHMOND
Write For Prices
MONTROSE GREENHOUSES
MONTROSE, MASS.

CARNATIONS
WINONA—The True Pink
\$12.00 per 100, \$100.00 per 1000

	Per 100	Per 1000
Red Chief.....	\$5.00	\$40.00
Aristocrat.....	6.00	50.00
Winsor.....	6.00	50.00
Beacon.....	6.00	50.00
White Perfection.....	3.00	25.00
Rose Pink Enchantress.....	3.00	25.00
Enchantress.....	3.00	25.00
Lady Bountiful.....	3.00	25.00

F. CORNER & SONS CO., LAFAYETTE, IND.

ROOTED CARNATION CUTTINGS
Only the Best Varieties
CHICAGO CARNATION CO., JOLIET ILL.
BARGAINS in TREES and PLANTS
Six for 25c, delivered free by mail
List Free D. J. TWOMEY, Dept. H., Geneva, N. Y.

Single Chrysanthemums ARE THE CRAZE
for the time being.
Are you in line to meet the demand?
I have now ready
KATIE COVELL, ROB ROY, HELEN TOTTY, HAROLD BISHOP, MRS. UNDERMEYER, ANNA SPANGLE,
and others, at
\$2.00 per doz., \$15.00 per 100.
I also carry a full line of novelties and standard varieties of
Chrysanthemums, Carnations and Roses
CHAS. H. TOTTY, MADISON, N. J.

JOHN E. HAINES
Bethlehem, Pa.
is the place to order rooted-cuttings of the following varieties for 1908.
John E. Haines, red imperial variegated Pink imperial, Pink Enchantress, Light Pink } Per 100 Per 1000
\$6.00 \$50.00
Place your orders early for Jan. delivery.
Carnation Cuttings
Both standard varieties and novelties. Stock guaranteed to be first-class. Address,
S. S. SKIDELSKY
1741 North 18th Street, Philadelphia

ROSES

100 of the best Hardy sorts.

HYBRID PERPETUALS

Finest English Grown Plants

Dozen, \$3.50; 100 \$25.00

EVERBLOOMING HYBRID TEAS

Bloom from Midsummer until frost.

Dozen \$5.00; 100, \$35.00

Hardy Climbing Roses

All the leading sorts.

Catalogue Free on Application.

R. & J. FARQUHAR & CO.

6 and 7 So. Market Street,
Boston, Mass.

The **MORRIS NURSERY CO.**
West Chester, PA.
NURSERIES ESTABLISHED 1849

SPECIALTIES for SPRING 1908

Norway Maple 2 1/2 in dia, and 2 1/2-3 in dia
carolina Poplars, 10-12 ft., 1 1/2-2 in.
Cal. Privet Hedge Plants, 2 yrs. old 2-3 ft.
and 3 and 4 yrs. old 3-5 ft Dwarf Box, 3-6 in.
Rhododendron Hybrids, 18-24 in. and 2-3 ft.
choice hardy varieties. Rhododendron
Maximum, 2-8 ft., fine plants in car lots.
Kalmia Latifolia 1-4 ft., fine plants in car lots.
Blue Spruce, Koster's, 3-5 ft.
Hybrid Roses, choice varieties.

Catalogue mailed upon request. Address all communications to

The **MORRIS NURSERY CO**
Sales office, 1 MADISON AVE., NEW YORK

Hardy Roses

American Grown—Superior to Imported

We have unsold at the present time the following varieties—all field grown plants, grown in our nurseries at Rochester, N. Y.:

Anne de Diesbach	Prince Camille
Clio	Edith Brunner
Frau Karl Druschki	Crimson Rambler
General Jacquemont	White Rambler
John Hopper	Yellow Rambler
Mme. G. Luizer	Philadelphia Rambler
Marshall P. Wilder	Common Sweet Briar
Mrs. John Luing	Mme. G. Brunt
Paul Neyron	Wichitana (The Type)

These plants are in our storage cellars and can be shipped at any time. Prices on request.

ELLWANGER & BARRY

Nurserymen—Horticulturists

Mount Hope Nurseries, Rochester, N. Y.

AMERICAN NURSERY CO., COMBIN- ING

FRED'K W. KELSEY, New York City
F. & F. NURSERIES, Springfield, N. J.
BLOODGOOD NURSERIES, Flushing, L.I.
N. J. & L. I. NURSERIES

We can supply your every need. Write for prices

Sales Department

150 BROADWAY. - NEW YORK

Hardy Rhododendrons Azaleas Conifers, Clematis, H. P. Roses, Shrubs and Herbaceous Plants from our

HOLLAND NURSERIES

Prices Moderate

P. OUWERKERK, 246 Jane St., Weehawken Heights
P. O. No. 1, Hoboken, N. J.

HARDY NURSERY STOCK

ORNAMENTAL and FRUIT TREES

Shrubs, Roses, Vines and Small Fruits

We make a specialty of supplying Florists' Trade, growing a complete line of everything that is hardy in the Northwest. Plants put up separately or in bulk, as they may desire. Full Line of Hardy Perennials. If you have not received our Wholesale Price List, write for it at once, or send list for Special Prices.

L. L. MAY & CO.,

ST. PAUL, MINN.

TAUSENDSCHON

or in English **Thousand Beauties**, is the sensational new Climbing Rose of the year. Every florist should have it. It is not excelled for forcing purposes and for general planting by any Climbing Rose now known, **not even bearing Crimson Rambler**. This is the coming forcing Rose. Get your stock early. Illustrated in ten colors and gold in our Catalogue for 1908, the **Leading Rose Catalogue of America**. Every Rose worth having is described in it. Copy free for the asking.

Strong plants of Tausendschon from 3-inch pots,
10 for \$1.50; \$12.00 per 100; \$100.00 per 1000.

THE DINGEE & CONARD CO.,

WEST GROVE, PA.

RHODODENDRONS, ANDROMEDAS, KALMIAS AND SPECIMEN EVERGREENS

JOHN WATERER & SONS, LD.

AMERICAN NURSERY

BAGSHOT,

ENGLAND

HARDY NORTHERN GROWN NURSERY STOCK

At Reasonable Prices

FRUIT AND ORNAMENTAL TREES, SHRUBS, VINES, ROSES AND
HERBACEOUS PERENNIALS IN GREAT VARIETY

Catalogue and Price List for the asking

BAY STATE NURSERIES, NORTH ABINGTON, MASS.

NEW NEW

RAMBLER ROSE "NEWPORT FAIRY"

To be disseminated Spring, 1908. Ask for Illustrated pamphlet and prices

JULIUS ROEHRSCO., Rutherford, N.J.

SPECIMEN EVERGREENS

Box Plants, Azaleas, Rhododendrons, Roses, Herbaceous Perennials

In fact everything in hardy stock for Garden, Lawn and Landscape Planting.
General Catalogue and Trade Lists on application.

The NEW ENGLAND NURSERIES, Inc., Bedford, Mass.

LIVE FENCES

We believe we are the largest growers of Hedge plants in America—Privet our specialty—can supply any quantity both

Amor River and California, strong plants, at \$25.00 per M. Other varieties. Prices on application.

PETER'S NURSERY COMPANY, - Knoxville, Tenn.

Notes From the Arnold Arboretum

With the exception of *Hamamelis japonica* of which I have spoken in the last issue there are at present in the Arboretum no other flowering trees or shrubs to attract attention. This does not, however, mean that bright colors are entirely wanting. The generally rather dull coloring of the bare shrubbery is enlivened here and there by shrubs with brightly colored branches, among the most conspicuous being several kinds of Dogwood. The best of them are *Cornus stolonifera*, the Red-Osier Dogwood, and *C. alba sibirica* with lighter more coral-red bark; in trade the latter is often erroneously called *Cornus sanguinea*; the true *C. sanguinea*, however, is a European species with dull dark red and thinner branches, less handsome than the Siberian Dogwood. Other good red-barked species are *Cornus Baileyi*, *C. Amomum* and *Cornus obliqua* (*C. Purpusi*). A pleasing contrast with these red-stemmed Dogwoods is formed by *C. stolonifera flaviramea* with bright yellow branches, a comparatively new variety and not yet so well known as it merits to be. It first came to the Arboretum in 1891 from Enfield, N. Y., and was subsequently distributed from here. Besides *Salix alba vitellina* it is perhaps the best yellow-stemmed shrub we have. Of the Yellow Willow there is also a pendulous variety, *Salix alba vitellina pendula* which is one of the best and hardiest weeping Willows in cultivation, combining a perfect pendulous habit with brightly colored branches. *Salix alba britzensis* is another brightly colored Willow but with red instead of yellow branches.

All these shrubs are most effective when massed together in larger groups and if winter effects are especially desired, it is to be recommended to cut them back occasionally, so as to produce a larger number of vigorous young shoots, for the one year old branches show the most brightly colored bark. The effect of planting in masses is well shown by the bands and groups of red-stemmed roses as *Rosa lucida*, *R. blanda* and *R. carolina* along one of the driveways in the Arboretum; in a single shrub the color would hardly be noticed, while these dark red masses particularly if seen from a distance, form a prominent feature in the wintry landscape.

Besides the red and yellow-stemmed shrubs there are many others with branches of various conspicuous colors too numerous to be mentioned. I shall here only draw attention to some species with bright green branches as *Kerria japonica*, *Cornus sanguinea viridissima*, *Rosa lucida alba*, several species of *Cytisus* and *Laburnum*, *Acer Negundo*, and *Sophora japonica* and to some shrubs with pale gray or whitish bark as *Elaeagnus argentea*, and *E. umbellata*, *Shepherdia argentea*, *Hippophae rhamnoides*, *Lonicera tatarica*, *Viburnum Opulus*, *Rubus occidentalis*, *Salix irrorata* and *S. daphnoides* and *S. acutifolia*. The whitest bark, however, we find among the trees in several birches as *Betula papyrifera*, *alba*, *pendula* and *populifolia* which on account of the brilliant whiteness of their trunks are at all times of the year a conspicuous feature in the landscape.

A few shrubs still hold their brightly colored fruits and thus add variety to the shrubbery. Easily the best of them is the now well known and appreciated *Berberis Thunbergii* whose scarlet fruits have lost but little of their brightness during the winter. Two other Barber-

ries whose fruits withstand the wintry weather equally well are *Berberis Sieboldii* and *B. Rehderiana*, but neither of them is as good as *B. Thunbergii*; their fruits are smaller and are not produced so profusely and the shrubs themselves are of lower stature and not suited for hedges. Also the common Barberry and its allies hold still most of their berries though considerably shriveled. *Viburnum Opulus* is another shrub whose clusters of brightly colored fruits though partly dried up are still a conspicuous feature of the shrubberies. Also the whitish fruits of *Myrica carolinensis*, the Wax-berry, and *Rhus Toxicodendron*, the Poison Ivy, are still hanging on to the branches and not without ornamental qualities, and so are the black or bluish black finish of the several species of *Ligustrum* and the lustrous black fruits of *Rhodotypos*.

Alfred Rehder.

Prunus Davidiana, Franch

Many of the cherries, peaches and almonds are most valuable for their ornamental qualities. To some of them the far-famed Japanese gardens and landscapes owe much of their charm. Yet much to our discredit we have hitherto given them but little space in our gardens and plantations. Of this worthy group the earliest to unfold its flower buds is *Prunus Davidiana*. In the vicinity of Boston it makes its display during the second week in April if the season is normal, though if the spring is somewhat forward the buds may begin to expand late in March. At any event we may feel sure that it will charm us with its floral offering before even the Forsythia displays its golden bells, or Spiraea Thunbergii whitens its arching branches. This dainty little tree is indigenous to northern China. Here it assumes a form very much like that of the common plum and attains a height of twelve to fifteen feet. The flowers, which are borne abundantly in advance of the leaves, are nearly an inch across and are white or pink in color. It is perfectly hardy in Massachusetts, yet its flower buds may occasionally suffer from the trespass of an untimely frost. For this reason it may be well to see that it has a somewhat sheltered place. Then too, its branches may sometimes be affected by the so-called "Japanese die-back;" yet this is not a serious menace to its use. As might well be expected from its relationship to the peach it is not a long-lived tree and may need replacing. Although not fastidious, it is distinctly a garden plant. It needs a well-drained soil, plenty of food and a protected location. It may be used to good advantage in the shrubbery with the more refined of the small trees and shrubs. Yet perhaps the very best association would be in a group composed of its attractive cousins, such as *Prunus pendula*, *Prunus subhirtella*, *Prunus Pseudo-Cerasus*, *Prunus triloba*, *Prunus Japonica*, and *Prunus tomentosa*. All in all it deserves to be much better known and more frequently planted. It has decided merit in the neatness of its habits, in the purity and charm of its flowers and in the timeliness of its florescence.

Daniel A. Clarke.

HORTICULTURE

VOL. VII

APRIL 4, 1908

NO. 14

PUBLISHED WEEKLY BY
HORTICULTURE PUBLISHING CO.
 11 Hamilton Place, Boston, Mass.

Telephone, Oxford 292
 WM. J. STEWART, Editor and Manager

SUBSCRIPTION PRICE

One Year, in advance, \$1.00; To Foreign Countries, 2.00; To Canada, \$1.50

ADVERTISING RATES

Per Inch, 30 inches to page \$1.00.
 Discounts on Contracts for consecutive insertions, as follows:
 One month (4 times) 5 per cent.; three months (13 times) 10 per cent.;
 six months (26 times) 20 per cent.; one year (52 times) 30 per cent.
 Page and half page spaces, special rates on application.

Entered as second-class matter December 8, 1904, at the Post Office at Boston, Mass.
 under the Act of Congress of March 3, 1879.

CONTENTS

	Page
FRONTISPIECE—White Killarney.	
NOTES FROM THE ARNOLD ARBORETUM—Alfred Rehder	437
PRUNUS DAVIDIANA—Daniel A. Clarke.....	437
OUR FRONTISPIECE	438
THE NEW AMERICAN CARNATIONS IN ENGLAND —M. C. Allwood	439
THE FERTILIZER QUESTION—Dr. B. T. Galloway..	439
AMERICAN ROSE SOCIETY: The Chicago Meeting (continued)—The Banquet..	440
PHILADELPHIA SPRING FLOWER SHOW.....	441
NEWS OF THE CLUBS AND SOCIETIES: Gardeners' and Florists' Club of Boston—New York Florists' Club—National Association of Gar- deners—New Orleans Horticultural Society—Tarr- ytown Horticultural Society—A Hustling Member —Club and Society Notes.....	442
OBITUARY: E. D. Darlington, Portrait—Simeon Sindhells— Peter L. Guigree—Theo. Williams—Jas. W. Ride- out—G. G. Haven.....	443
INDOOR COMMERCIAL ROSE CULTURE—Eber Holmes	443
SEED TRADE	446
QUALITIES OF FORMOSA LILIES.....	448
ANCHUSA ITALICA VAR. DROPMORE—Frederick L. Rea—Illustrated	448
OF INTEREST TO RETAIL FLORISTS.....	450
FLOWER MARKET REPORTS: Boston, Buffalo, Detroit, Indianapolis, New York, Philadelphia, Washington	453
MISCELLANEOUS: Cherokee Rose	441
Personal	441
Plant Imports	446
Publications Received	447
News Notes	450
"Grandmothers' Day" in Philadelphia.....	453
Business Changes	453
Incorporated	453
Greenhouses Building or Contemplated.....	461
A Low-Priced Level.....	461
Hail Losses	461

which it has so long enjoyed abroad. The Hills, Dawsons, Walshes, Cooks, Mandas and Montgomerys of the coming generation will rapidly multiply. The Egans, Hiawathas, Rhea Reids, Wellesleys and Cardinals of today, beautiful as they are, are destined to be superseded by children fairer, more productive, continuous-blooming, yet absolutely hardy. All honor to the men who have had the courage to take the initiative.

Our readers who recognize the importance of and appreciate HORTICULTURE'S continued efforts to provide instructive horticultural literature from the most advanced standpoint will be pleased to know that the series of notes from the Arnold Arboretum by Mr. Alfred Rehder, begun in our issue of last week, will be continued regularly throughout the year. The new plants brought to light by Mr. Wilson in his North China explorations will be fully noted by Mr. Rehder in these columns as fast as their horticultural value in America is demonstrated under the unerring eye and hand of Jackson Dawson. It is on the lines herein suggested that we look to see the most notable horticultural advancement during the next decade. As heretofore remarked, HORTICULTURE hopes to do its humble part in helping to spread the light of progress in these coming days which promise so much. In this respect we have other good things in store. Tell your friends.

The problem which intruded itself so forcibly at the American Rose Society exhibition in Chicago of how to do full justice in judging exhibits from a long distance in competition with those of local production is one which has already assumed a disturbing importance in the American Carnation Society and is sufficiently serious to warrant immediate consideration and prompt adjustment if possible. So long as the rules and system of judging leave the judges no option but to base their conclusions solely upon what is in sight at the moment of judging it cannot be expected that exhibitors from a distance will subject their product in the classes of material which are sure to lose certain values by long transportation, to the chances for discredit thus presented. If these societies whose shows must, in the nature of things, be composed of perishable material would have their exhibitions anything more than local affairs it seems imperative that concessions in some form in the interests of distant contributors must be forthcoming. The "zone" system with a certain number of points or fractions of points conceded on color or other changeable qualities according to miles traversed seems to present the best solution.

Our Frontispiece

Our frontispiece shows one of the most promising roses ever introduced to the American trade. Killarney has more than "made good." White Killarney, originating with the prince of rose growers, Alexander Montgomery, is destined to take a position of leadership in the commercial cut flower trade, putting into the shade the varieties that have for many years been indispensable. We learn that the F. R. Pierson Company, of Tarrytown, N. Y., has secured one-half interest in this sterling novelty—another evidence of the far-sighted judgment of the man who first discovered carnation Winsor.

Earnestly hoped for but long deferred, the day of the American rose seems at last to have dawned. Devoted men have been working and experimenting during the past few years on many lines which might furnish a possible basis for development of new races adapted to the peculiar conditions of American climate, and now that the foundations are laid we may expect to see results follow in rapid succession which will stimulate rose breeding and ultimately bring rose culture in this country to the pre-eminence

The rose in
the ascendant

The New American Carnations in England

With the great contrast between the climate of England and America, it is surprising what similar verdicts are arrived at in the judgment of the new varieties of American carnations. It is the simple truth which tells in the end; all the beating of drums and clanging of cymbals in the world will not make a bad carnation a good one. And if good, no matter if grown in the sun of California, or the smoke of London, they produce mighty fine flowers.

While many of the small growers over here do not test any of the new American introductions, others do so only in small quantities and are not really in the position to judge. At Bush Hill Park we bite rather largely at some of the novelties, yet more often, I am inclined to think that we are in the position of the cat, while the monkey was using its paw to get the chestnuts out of the fire. In other words, the small grower greatly prefers that a large grower shall cultivate and show the novelties for the first year, get the stock well climatised, and, I might add, free from disease, because it is wonderful how invariably this is in the crate as packing, yet much of it, I am inclined to think, is created on transit. Still that does not alter the fact that it is there and requires getting rid of, because the average British grower has a great abhorrence of rust.

The loss, again, is no small item in importing carnations from America, and often those that you save figure out as very expensive plants. We all realize that practically the last word has been said in the matter of packing, so we do not look for better results in the future.

Aristocrat came over very badly diseased and was slow to make a start away. We grew it under glass all summer, and commenced to cut in mid-September. The formation of the flower is considered almost ideal, the great fault being the color, which has too much magenta in it for British taste; its stem is good and calyx held well throughout the London fogs.

Beacon is unanimously voted the best scarlet; in fact it is most difficult to find any fault with it. We all have a very warm corner in our hearts for the raiser of it. We grew it indoors all summer, started to cut early and have been cutting ever since.

Winsor is another general favorite, all the best London shops having a strong fancy for the color, and its short stem in the early part of the season is not too strongly objected to, yet the Britisher dearly loves a more shapely flower.

White Enchantress is good, and all like it, yet White Perfection leads in purity of color; as yet there is no great rush for this child of a noble sire.

Rose Pink Enchantress is disappointing; the dull days cut its unstable color up sadly, yet when the stock has been more rigidly selected down to a true shade, it may live on.

Imperial and Pink Imperial are not of a habit which

is popular in England, and the color of the former is not bright enough to become a favorite, while the latter is pretty without being great.

Red Riding Hood we did not stock, and those who did, wished they had not.

Red Chief is the right color and would have had a great future in Britain if only larger, yet under the circumstances life will be short.

Victory is just coming into its own: it has regained its health and with us is remarkably fine, but all last season it was very sick itself, and made all of us feel quite bad.

Britannia is a general favorite throughout; it flourishes wonderfully well under pot culture, the deep rich color being popular.

Mrs. H. Burnett, another of last year's British introduction, has won favor in some localities, the salmon pink color being a most popular shade in London.

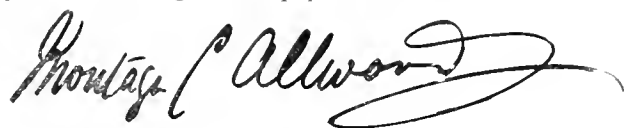

Bush Hill Park.

The Fertilizer Question

Editor HORTICULTURE:

Dear Sir:—My attention has been called to a statement in a recent number of HORTICULTURE regarding remarks made by me before a recent meeting of the Carnation Society concerning the use of chemical fertilizers and their effect on the production of carnations.

In order that I may make my position perfectly clear I may say that after a good many years of experimenting under glass on crops of different kinds, we have reached the following conclusions and it was these conclusions that we referred to in our talk before the carnation people:

- (1) That so far as the securing of healthy plants and the production of profitable crops of flowers was concerned, fully as good results could be secured by the use of good composts alone as where chemical manures were applied.
- (2) That florists were prone to over-estimate the value of chemical manures, especially bone, in the growing of crops.
- (3) That the more highly concentrated and soluble the chemical manures used, the more likely there was to be injury resulting therefrom, owing to the fact that it was exceedingly difficult to properly gauge the handling of these materials in the growing of crops under glass.

We stated, I believe, and will repeat that if we were in position to always get good well decomposed stable manure, either cow manure or horse manure, we would want nothing better in the growing or forcing of crops under glass.

Very truly yours,

B. T. GALLOWAY,

Chief of Bureau.

AMERICAN ROSE SOCIETY

THE CHICAGO MEETING CONTINUED.

W. A. Manda's talk on outdoor roses at the Wednesday evening session was very interesting. He called attention to the fact that there are on record in Paris the names of 11,016 varieties and species of roses and in a private collection in that city some 8000 varieties. He recommended the laying out of rose gardens on more or less formal style with beds from five to six feet wide and of varying length and planting the roses in rows leaving room between the plants for cultivation. He said it was a good plan to put the H. P. sorts in the centre row and the H. T.'s, which are not so tall growing, on the outside and the beds would then look well all through the season. Standards and ramblers placed at intervals lend variety, the latter being adapted for pillars and arches up to 20 ft. in height. For hedges he recommended *Rugosa* as most useful. For a protective hedge nothing equals the *Wichuraiana* hybrids. He declared that people do not prune roses as severely as they should. Old wood should not be allowed to remain. In the discussion which followed, Wallace R. Pierson said it was his intention to plant five hundred white and pink Maman Cochet roses for summer cut flowers, as an experiment.

J. F. Sullivan's paper on Roses for Decorative Purposes, delivered on Thursday morning was, as briefly noted in our previous notes, very favorably commented upon. Philip Breitmeyer commended it warmly and called attention to the increasing call by flower buyers for the old-fashioned small varieties such as *Bon Silene* and *Safrano*. He spoke reminiscently of Boston's priority in the growing of these pioneer varieties years ago and submitted that, from the evidences in the present exhibition, Boston was "still in the ring." W. J. Stewart followed Mr. Breitmeyer in appreciation of Mr. Sullivan's effort. He believed that the rapid recent development in varieties of large size had now left room for the existence of buds of the *Bon Silene* type as a separate class, adapted to special uses and with a remunerative commercial value in the flower market. He said that Boston could not aspire to compete with Chicago in its vast ranges of rose growing houses, or its unlimited market for the productions of same but, as in the case with all New England agricultural and manufacturing industries Boston's position as the producer of the highest type of flowers would be maintained, quality rather than quantity being a proposition forced upon the New Englander by natural conditions and restrictions from which he could not escape.

Following W. H. Elliott's very practical paper on the size of commercial greenhouses, A. Farenwald remarked that in his opinion success in rose

forcing was not dependent upon the size of the house but the ability of the man operating it. He spoke of the great dangers of wind pressure in the case of vast roof surface and thought that the only question to consider in comparing large and small houses was that of economy. Mr. Elliott in reply maintained that wide and lofty houses may be heated with a proportionately lesser amount of pipes than small houses. Thorough construction would solve the wind-pressure problem and it might yet be a question as to whether houses might not be constructed large enough to ensure all the pure air needed without any provision for ventilation other than to prevent over-heating in the day time.

On Friday morning, March 27th, President Simpson read an invitation from the Horticultural Society of New York, to hold a June Rose Show, in connection with that body, in Bronx Park, New York City. This matter had been brought up before the Executive Committee by Ex-President Frederick R. Newbold last November. Upon motion of Mr. Valentine it was voted that The American Rose Society accept the invitation and join with the New York society in its June Show, and that the Secretary extend the thanks of the Society for the invitation, which is without expense to the American Rose Society for accommodation or service.

The paper by George B. Maynadier, of the Bureau of Soils, Department of Agriculture, on the subject of Soil—the constituent parts, the effect of water, etc., was closely followed. John Thorpe related some experiences where *La France* grew at Nyack, N. Y., with much vigor—and other varieties at Madison, N. J., illustrating by his experiences the force of the suggestions of Mr. Maynadier.

The vital question of the growth of the Society was taken up by Secretary Hammond and laid before the meeting in detail—the step taken to produce a publication as a means of extending the influence of the Society interesting the membership at large—the prospectus sent out and the responses in return shown. All present took much interest and some part in the discussion. Frank R. Pierson, said he was heartily in favor of the project, but suggested that, in lieu of any advertising support, the needed backing be done by direct subscription to the fund. In response to Mr. Pierson's suggestion, a number of gentlemen present started a subscription list with a substantial sum and the meeting endorsed the project, leaving it in the hands of the Executive Committee and Secretary.

The paper received from Mr. Alexander Dickson, of Newtownards, Ireland, was then read. Upon motion of Mr. Farenwald it was ordered that the Secretary be directed to convey to Mr. Dickson the thanks of the Society.

Mr. Robert Craig's paper was presented by W. P. Craig and a vote of thanks given as it was a pertinent subject of much interest.

The question of the desirability of

incorporating the American Rose Society under a State law was raised and referred to the Executive Committee.

In addition to the list of prizes won at the exhibition as given in last week's issue there should be mentioned F. R. Newbold's special for 25 blooms of *Uncle John*, which was won by Poehlmann Bros., the John Davis prize for 100 Mrs. Marshall Field, awarded to Peter Reinberg, and the specials offered by Peter Reinberg for the men who did the actual growing of the exhibits considered, which were awarded to the growers for W. M. Elliott, Poehlmann Bros., and A. Farenwald, first, second and third respectively. The sweepstake silver medal offered by the Horticultural Society of Chicago for the best vase of roses among the prize winners was won by W. H. Elliott's vase of *Killarney*. Miss M. I. Hammond's special for the most beautiful exhibit in the hall was decided by vote of the ladies visiting the exhibition to belong to the group of rose plants shown by Vaughan's Seed Store.

Wyndmoor is said to be a cross between *American Beauty* and *Safrano*. It pleased everybody by its fresh, bright appearance at the exhibition after its journey of nearly a thousand miles. The flower is handsomely modelled, rich pink in color, and the foliage is similar to *Beauty*.

Victory, *Aristocrat*, *Afterglow*, *Winsor* and *White Perfection* were on deck and well-represented the progress in carnation culture up to date.

Most favorable comment was made on the splendid keeping qualities of *Cardinal* in the exhibition. Messrs. Poehlmann Bros. regard this handsome, fragrant crimson rose as a commercial winner.

Chicago treated the visitors to a great assortment of weather, all of which was borne without murmur until the blustering rain storm of Friday, which at times put an embargo on outdoor locomotion.

Newport Fairy, although passed over by the judges with merely a commendatory mention, attracted much attention and was greatly admired. It is said that the similarity of its flowers to those of *La Piamma* was the cause of its side-tracking, but the glossiness of its foliage, its floriferousness and graceful habit gave it a high place in the estimation of all.

Mme. Chatenay showed up in grand form, but it looks as though Mrs. Potter Palmer in time place it where *Bridesmaid* placed the *Catharine Mermet*—in seclusion.

THE BANQUET.

The banquet at the Union Restaurant on Thursday evening was enjoyed as all such affairs are, by both visitors and hosts. A touch of sadness was added by the sudden calling away from the table of genial Phil. Foley who was to have officiated as toastmaster, owing to the death of his brother's child. W. N. Rudd was called upon in the emergency to fill

the vacant chair and with customary adaptability and ready wit did full honor to himself, his guests and the occasion. The visiting ladies in the meantime were taken to luncheon and the theatre under the guidance of Mrs. J. C. Vaughan and other ladies of Chicago, and we learn from reliable sources that they had a glorious time "all by themselves."

Leonard Kill, president of the Chicago Florists' Club, opened the post-prandial exercises with a few well-delivered words of welcome. Toastmaster Rudd then assumed authority and, by way of diversion introduced president Traendly of the S. A. F. to respond for the American Rose Society and president Simpson of the American Rose Society to respond for the S. A. F. Both gentlemen responded in satisfactory manner. Ex-president W. J. Stewart was next introduced as having served the longest official term in connection with the parent society and responded accordingly. President Kill was here induced to say a few more words—the toastmaster's comment thereon being "His oratory is fine but the quantity deficient." Next came Philip Breitmeyer with a nice complimentary speech and then Secretary Hammond with an eloquent tribute to the rose, its influence in the home and in the garden. J. C. Vaughan next spoke for "Horticulture in Chicago" and W. F. Kasting followed with a characteristically practical talk on the meeting and exhibition of the American Rose Society to be held at Buffalo next year. J. A. Valentine, introduced as "the man always there—no matter where" made a witty speech. E. V. Hallock spoke for the school garden question, saying that "it beats any other thing you can get up." Then the toastmaster drew upon his special reserve of wit in introducing P. Welch of Boston who returned the compliment with a sally that brought down the house and coolly told the Chicagoans that they got all their hustlers from Massachusetts. W. H. Elliott was the closing speaker on behalf of the rose growers.

CHEROKEE ROSE.

Horticulture Pub. Co.

Gentlemen:—We note on Page 367 of the March 21st issue of HORTICULTURE reference made to the Cherokee rose, and the question asked in connection with it why "some enterprising grower does not take up this beautiful variety." Not wishing to throw any bouquets at ourselves, would say that we have the Cherokee rose in stock, and have had it for many years, and while we do not have large quantities we can supply a reasonable demand for it. We figure, therefore, that we must be numbered among enterprising growers.

Yours very truly,

THE DINGEE & CONARD CO.,
P. J. LYNCH, Treas.

West Grove, Pa.

Our remarks in reference to the Cherokee rose were meant to apply to its forcing for cut flower purposes. Perhaps "some enterprising grower" will be glad to know where the stock may be procured.

Come on, April, through the valley,

In your robes of beauty drest,

Come and wake your flowery children

From their wintry beds of rest.

Come and overblow them safely

With the sweet breath of the south;

Drop upon them, warm and loving,

Fenderest kisses of your mouth.

—Phoebe Carey.

PHILADELPHIA SPRING FLOWER SHOW.

Among the features of this annual event, which occurred on Tuesday, Wednesday and Thursday last, were the big azaleas from the Newbold estate at Jenkintown. These measured seven feet in diameter and were perfect in flower and foliage, a dazzling picture. It is claimed that no such plants can be bought in Europe or America today at any price! Mr. Batchelor deserves credit for their superb condition, and won a first prize the money value of which was far below the intrinsic merit of the exhibit. Obconica primulas from the same place were the largest flowers ever seen here—high-colored and as big as a silver dollar, but the first in this class went to larger plants with smaller flowers. The latter were from the Pepper estate. We think the judges should always lean to quality rather than size where the schedule will permit, which they do not seem to do. There was a fine exhibit of geraniums from Batchelor, but the bigger and commoner plants from the Paul estate got first. Now, in both the obconica and the geranium exhibits the verdict ought to have been exactly the reverse—in order to give due emphasis to quality over quantity.

The main display consisted of spring flowering subjects, such as hyacinths, tulips, daffodils, Easter lilies, callas, etc.—outside of the subjects already mentioned. In these classes the more prominent prize-winners were: William Kleinheinz, Samuel Batchelor, John McLeary, Wm. Robertson, Joseph Hurley, Jno. Hedland and Thomas Long.

The centre of the main hall had the time-honored pagoda built by the Graham Co., white pillars draped, festooned with vines, decorated with plants and flowers and electric lighted.

In front of the stage, for the Dreer premiums, was an interesting group of plants, among which were the white and pink Baby Rambler roses; a fine lot of amaryllises, *Primula Sieboldi*; *Pteris Childsi* and *Asparagus Colemani*. A fine group of foliage plants was put up by the Paul estate. Lager & Hurrell, Julius Roehrs Co. and Alphonse Pericat each staged a good collection of orchids. J. Goodier, gardener to C. G. Roebing sent an exhibit of amaryllis—magnificent as to size and varied in color. It is a long time since we have seen such flowers. *Azalea mollis* was in evidence, splendidly flowered; but with no foliage. Flowers without foliage were seen in other shrub sections, and were not particularly pleasing, artistically. Some good forced lilacs were shown with good foliage. The finest *Amerpohli* fern we have ever seen graced the top of the main stairway. It was a perfect ball, every frond faultless, full to the centre, three feet in diameter and as many deep. Give Mr. Robertson credit for this beauty. *Todaecoides* and *Piersoni* ferns graced the newel posts—fine specimens. *Michell* and *Dreer* occupied the rotunda with seasonable exhibits of seeds and tools. Some fine specimens of *Cineraria stellata* were used effectively at top of stairway. Louis A. Conche made an interesting exhibit of Erfurt broad leaved water cress. A first

prize went to a splendid specimen of ferns—sporadocarium variety of *Polypodium* with glaucous green foliage—from Thos. Long, five feet through. Wm. Kleinheinz took first in cut roses with a fine lot of Golden Gates. Robertson carried the honors in cut carnations. *Calla Rossi* (among which was one with a double spathe) was an interesting exhibit. This variety is a deep yellow—purple in the throat—a lovely thing! *Calla Devoniensis* was also well shown.

Newport Fairy rose from Roehrs' captivated everybody and was a bright spot in the show. Wyndmoor rose, fresh from its Chicago honors, was shown in fine shape, by Myers & Samtman. The finest crimson hyacinth was *Roi des Belges*. Nothing can beat this for shining brilliancy, size and form. *Queen Alexandra*, the pink spirea, was well shown in various collections—the best colored lot being staged by Robertson. In the daffodil exhibits *Princess Ida*, a lovely pure white trumpet, was conspicuous, as was *Glory of Leyden*, C. J. Backhouse and *Queen Victoria*. Among the tulips worthy of notice were *Everdina Jacoba*, *Sulphur Murillo*, *Hobbema*, *White Van Vondel*, *Lord Beaconsfield* and *Queen of the Netherlands*. *Mon Tresor* is still the loveliest yellow. *Prince of Austria* is a grand new orange red. James Coleman, gardener for Walter Lippincott, exhibited some fine English wallflowers in pots. The darkest crimson rhododendron, according to H. Waterer, is *De Brun*, and this variety was well shown in the stairway exhibit.

PERSONAL.

Adam Graham, wife and two daughters are spending a few weeks at Tryon, N. C.

J. A. Newsham, of New Orleans, sailed for Central America on March 19. Many of the members of the Horticultural Society were at the boat to see him start safely on his journey.

Arthur Niessen, Philadelphia, who has been ill for the past five weeks with typhoid, is now convalescing favorably at Atlantic City, and expects to be back at work before Easter.

Robert Hunnack, gardener for W. B. Leeds of Newport, R. I., sails on S. S. *Mauretania* on April 22 for a six months' visit to England. His wife accompanies him. Mr. Hunnack was gardener to F. W. Vanderbilt for nearly twenty years.

Francis Canning has returned to Villa Nova, Pa., where he will again have charge of the Bodine greenhouses and grounds. He is as enthusiastic as ever—his five years as instructor at Amherst, Mass., having broadened but not dulled the keen edge of his horticultural progressiveness. His Philadelphia friends will be glad to see him often around the club and society meetings as of yore.

NEWS OF THE CLUBS AND SOCIETIES.

GARDENERS' AND FLORISTS' CLUB OF BOSTON.

Once a year this organization has a good social time with ladies, music and refreshments. This year there was a division of views as to what form it should take, some wanting a banquet, others a dance. The problem was threshed out at one of the meetings and the banquet men won, much to the chagrin of the dance men. But Boston likes to emulate her good sister, Philadelphia, in the matter of harmony and so a dance was hitched on to the banquet and so everybody was made happy. The affair came off at Horticultural Hall, Boston, on Wednesday evening, April 1, about 275 members with their ladies sitting down to the banquet tables, and the tables and alcoves were beautifully adorned with flowers and plants generously contributed by members of the club. Wm. Sim out shined himself by presenting every lady with a bunch of one hundred luscious violets and the irrepressible treasurer, Ed. Hatch, had placed at each guest's plate a little box presumably containing jewelry, which it did—a safety pin—this being Mr. Hatch's April first joke, for all of which he fully atoned by inviting everyone to visit the "old mill" which he had erected at one end of the hall and imbibe a sample of the old mill's product.

After the food had disappeared Treasurer Hatch took up his duty as inimitable toastmaster and successively called upon President Westwood, Secretary Craig, J. K. M. L. Farquhar, Vice-President Downs, and a galaxy of singers and musicians, who provided entertainment of a high order. Then the floor was cleared and the dancing began—lasting into the indefinable—and it goes without saying that old men and matrons, young men and maidens as represented in the club which is Boston's pride had "the time of their lives."

It was announced that the next "field day" would be Saturday, April 11, when the club would, upon invitation, visit Thomas Roland's greenhouses at Nahant. The members will take train for Lynn at the North Station, 12.30 P. M., and will be met at Lynn by Mr. Roland with his chargers.

NEW YORK FLORISTS' CLUB.

Secretary Young has arranged for the following exhibits at the next meeting of the New York Florists' Club at the old club rooms in the Grand Opera House Building, 5th Ave. & 22nd St., Monday, April 13th:

Roses—"Newport Fairy" from Julius Roehrs Co., Rutherford, N. J. "Rhea Reid" from E. G. Hill & Co., Richmond, Ind. "Wyndmoor" from Myers & Santman, Philadelphia Pa. "My Maryland" from John Cook, Baltimore, Md. "Mrs. Potter Palmer" from Pochlmann Bros. Co., Chicago, Ill. "Mrs. Jardine" from W. P. Craig, Philadelphia, Pa., and "Cherokee," from W. A. Mandt. Carnation "Lloyd" from H. A. Jahn, New Bedford, Mass.

NATIONAL ASSOCIATION OF GARDENERS.

The National Association of Gardeners opened its fourth annual convention in New York on March 19. An interesting talk was given by P. O'Mara on Thursday P. M., in which he attributed to the private gardener and his employer all that is highest in horticultural lines, and commended the policy of the association. A dinner was given on Thursday evening followed by an instructive talk by Prof. Powell regarding planting and handling of an orchard, and brief but entertaining remarks by P. O'Mara, Harry Bunyard, H. S. De Forest, L. W. C. Tutthill and others.

The display of flowers included many novelties. The Pierson U-Bar Co. cup was awarded to Prof. Osborn, Jas. Bell, gardener. In carnations, the contest for first was close between Jas. Pell and Mr. Wynne, gardener for W. W. Herroy, and an equal prize was awarded—a silver cup offered by P. Henderson & Co. Oscar Carlson took first on carnation seedlings, his No. 14 being a deep crimson; J. P. Sorenson was second with a variegated seedling from Prosperity. The Bobbink & Atkins cup was won by J. P. Sorenson on roses. John Shore was first on violets, Wm. Brabenburg first on hardy bulbs.

The business meeting was held on Friday and the by-laws were amended fixing the annual dues of associate members at \$2 instead of \$10, as previously. The board of directors was elected: A. Allum, James Bele, A. Bullen, Chas. Dumper, E. J. Day, Jas. Delaney, Chas. Elliott, C. Gebhardt, John Hays, T. J. Kempton, Robt. Meeks, W. Paget, T. Runieville, J. P. Sorenson, C. Shaeffer, J. Shore, J. Tiplady, J. Wallace, C. T. Zapel, W. E. Maynard.

NEW ORLEANS HORTICULTURAL SOCIETY.

The regular meeting of the above society was held on March 19, presided over by President Chas. Edle. At a special meeting held March 5 the committee on chrysanthemum show reported that they had prepared a premium list which would be distributed as soon as ready. It was decided to have a special class of cut chrysanthemums for growers outside of Louisiana for the purpose of getting entries of new varieties from our northern and eastern friends who supply the great bulk of cut flowers to this city. It was further decided that non-members of the society would be charged one-half of the first prize premium; said amount to be paid to the secretary before the opening of the show. The probable dates of the show will be November 12-15, inclusive. Special prizes will be given to the public schools for exhibits. A. Alost announced that at the next meeting he would give the date for the annual visit to his place. R. Eichling of the U. J. Virgin establishment exhibited *Lilium Harrisii* and lily of the valley.
CHAS. R. PANTER, Secretary.

TARRYTOWN HORTICULTURAL SOCIETY.

A well attended meeting of this society was held on March 27th. President Angus filled the chair and in the absence of Secretary Neubrand, Wm. Scott was appointed secretary pro tem. Letters were read from donors to our prize fund for the next fall exhibition, and most of the prizes given last year will be duplicated, so the outlook is bright for the November show. The committee in charge are busy preparing the schedules, which will be sent to all interested in due time. The prize for cyclamens, presented by Wm. Scott, was awarded to James Stuart, gardener to Mrs. E. A. Constable; also a cultural certificate. Mr. Stuart brought eight plants in 6-7 inch pots, which were perfect in every way and were greatly admired. He was also awarded a cultural certificate for a large plant of *Dendrobium nobile*, in full bloom. W. H. Waite, gardener at Greystone, received honorable mention for a vase of schizanthus.

Mr. Tibbits, White Plains, N. Y., will at our next meeting give an illustrated lecture on "Aquatic Gardens." He has been very successful with aquatic plants and we anticipate a pleasant evening. A prize is also offered by Wm. J. Smith, White Plains, N. Y., for best two flowering plants.

L. A. MARTIN, Cor. Sec.

A HUSTLING MEMBER.

We learn that Theodore Wirth has by personal solicitation secured this year for life membership in the S. A. F. the following named gentlemen: John Monson, O. A. Will, Hugh S. Will, L. S. Donaldson, J. M. Underwood, R. A. Latham, Thos. W. Nagel, James Souden, all of Minneapolis; E. P. Holm, A. S. Swanson and L. L. May, of St. Paul; Alois Frey of Chicago. If all the parties who have from time to time taken occasion to bemoan or criticize the limited membership list of the national society would get busy and emulate the example of Mr. Wirth, how different things would be! Here is an object lesson for every member not only of the S. A. F., but of all clubs and societies.

CLUB AND SOCIETY NOTES.

The California State Floral Society met on March 13 in San Francisco and nominated H. Plath for president, Mrs. F. J. Halpin, corresponding secretary. The annual flower show will be held May 14, 15 and 16.

At the meeting of the Springfield (Ill.) Florists' Club on March 16, officers were elected as follows: President, Carl Rauth; vice-president, R. T. Donnell; secretary, Frank A. Friedly; treasurer, Geo. Van Horn.

The Cape Ann Horticultural Association, organized in the early 60's, met at City Hall, Gloucester, Mass., March 19, and voted to disband and to donate the funds on hand to the Huntress Home.

Obituary

E. Dillwyn Darlington.

The brief announcement in last week's issue of HORTICULTURE of the sudden demise of Mr. Darlington came as a shock to his many friends in all parts of the country. He had been ill with pneumonia only four days and no one expected a serious result. The funeral was largely attended on Monday, the 30th ult., by personal and business associates, the Burpee establishments at Fordhook, Sunnybrook and Philadelphia being shut down out of respect to his memory and to give all a chance to attend the last sad rites. Mr. Burpee had only just started on an extensive tour to the South and West, but broke all engagements and hurried back home, Mr. Darlington, like most of the Burpee forces, being not only an employe but a warm personal friend of the proprietor. The grief of every one, from the highest to the lowest, was heartfelt and sincere. Not only



E. DILLWYN DARLINGTON

has the Burpee establishment suffered a severe loss but the trade at large and his local community have cause to mourn a splendid personality cut off in its prime of usefulness and well doing. By tongue and pen Mr. Darlington was ever ready to impart to his fellow men from his rich store of knowledge, and no amount of labor or personal inconvenience ever stood in his way when the call of duty sounded to the platform or the printed page. Mr. Darlington has been in charge of the Burpee trial grounds at Fordhook for twenty-five years. Previous to that he had been in the commercial florist business at Doylestown. This, with the experience of trees and shrubs in the nurseries of Hoopes Bro. & Thomas at West Chester and his work during the winter months at the Burpee seed warehouses in Philadelphia, made him an all-round man of exceptional attainments. His mother, his widow and three children, also two brothers and three sisters survive him. We extend to them, to his firm and to

his business associates our heartfelt sympathies. It will be a long time before we find as good an all-round man for the niche in our wordly affairs which he filled so ably and well.

G. C. W.

Simeon Sinnrells.

Simeon Sinnrells, a one-time florist, grower and retailer of the District of Columbia, died at his home in Anacostia, March 26th, after a long and painful illness. He was one of the pioneer florists of the District and did a great deal to raise the standard of the business in this locality. For a number of years past ill health had prevented his following this vocation.

Peter L. Guigue.

Peter L. Guigue, a florist of Long standing in Norwalk, Conn., died on March 19. Mr. Guigue came to that city from Germany in 1866 and was employed on the Le Grand Lockwood place until he started in business for himself. He was a kind-hearted, public-spirited man and will be greatly missed.

Theodore Williams.

Theodore Williams, a pioneer horticulturist of Omaha, Nebraska, died on March 16, aged 60. Mr. Williams was especially interested in fruit raising, and some of his methods of grafting have become well known in all sections of the country.

James W. Rideout.

James W. Rideout, a florist in Boston until his store was destroyed in the big fire of '72, later superintendent of the cemeteries of Quincy, Mass., died on March 30, at the age of 74.

George Griswold Haven.

George Griswold Haven, who died in New York, March 18, was the owner of Sunyeroft, at Lenox, Mass., and a frequent exhibitor at the Lenox shows.

We have received sad news of the death on March 29 of the father of R. F. Gloede at the residence of his son in Evanston, Ill. Mr. Gloede's business associates, and his many friends in the Society of American Florists of which he has long been a member, will sympathize with him in this loss.

The Canadian Florist reviews the admirable work done for the city of Toronto by John Chambers in the twenty-nine years in which he has filled the position of park superintendent, and the stimulus his enthusiasm and progressive ideas have given the trade, and adds: "The great difficulty the city is experiencing in finding a suitable and competent successor to Mr. Chambers shows how eminently well qualified he was for the position."

INDOOR COMMERCIAL ROSE CULTURE.

A Paper by Eber Holmes before the Gardeners' and Florists' Club of Boston.

(Continued from page 509)

Filling the Houses.

We have used loam for planting after being piled up one and two years, and have also used it plowed and chopped up in the field one day, and in the house planted the next without any different results. I would, however, prefer four to six inches of sod rotted and chopped up with cow manure. If this has been put together the previous to plant in. On large places the old fall so much the better, for it is easier method of piling up soil ahead has given place to the horse and disc harrow in the spring.

The large houses are easier to fill than the old style where a man pushed a wheelbarrow 100 feet or more. A house up to 40 feet wide can easily be filled by removing glass or sash in the sides and driving teams alongside with the loam. Five or six men make a good gang for operating these houses when filling. With two or three men outdoors loading and unloading the carts and three or four inside, placing, treading and leveling, good progress will be made. Before filling, all woodwork should be whitewashed, or receive a dusting of air-slacked lime. We also use lime mixed with the soil for planting and particularly in loam and manure for top dressing. It is a very good and cheap fertilizer and sweetener of the ground and might be used a great deal more freely than it is.

Planting.

Before commencing to plant, if the weather is hot, we use a light shade of whiting syringed on the glass. It is cheap, quick to apply, good for the men and plants while the work is being done and can be washed off with the hose if rain does not come in time to take it off. I do not like a line for planting young stock as it is in the way and takes too long to move around. We use a marker made of light strips of wood with pegs fastened on. One man can handle it—two men, one on either side, may work quicker. Being the same width as the bench boards it cannot get out of line, and the distance in the row is obtained by following the end mark every time it is moved. It will make 20 holes every time it is moved and enables a bed to be carried through at once. Team work comes in to good advantage in planting where it is important to transfer them quickly. A good man should be detailed to pick out the stock, for it is useless to waste time on poor plants. It will take one or two men to pick out the plants and knock them out into flats, one with a wagon to cart to the house where they are to be planted, a couple to dig holes,

HARDY ROSES FOR THE GARDEN

Strong Field-grown Plants

The roses here offered are extra strong two-year-old field-grown blooming plants, which if planted early, will give a large number of flowers the first year. They can be planted as early in the spring as the frost is out of the ground, and from that time until about the first week in May. We offer a grand collection of the best and choicest varieties, as follows:

HYBRID PERPETUAL OR JUNE ROSES

Frau Karl Druschki, Marchioness of Londonderry, Capt. Hayward, Mrs. R. G. Sharman-Crawford, Ulrich Brunner, Margaret Dickson, Baron de Bonstetten, Paul Neyron, Gen. Jacqueminot Magna Charta, Mrs. John Laing Mme. Gabrielle Luizet, Marshall P. Wilder, Gloire de Paris, Baroness de Rothschild, Prince Camille de Rohan Fisher Holmes, Alfred Colomb, Soleil d'Or, Persian Yellow, Moss Roses, Rugosa alba and rubra, etc.

MONTHLY AND HYBRID TEA ROSES

Etoile de France, Hillarney, Mme. Abel Chatenay, Countess of Gosford, Koenigen Carola, Perle von Godesberg, Gruss an Teplitz, Maman Cochet, White Maman Cochet, Belle Siebrecht, Hermosa, Mme. Caroline Testout, Souv. de Pres. Carnot, Kaiserin Augusta Victoria, American Beauty, La France, Clothilde Soupert, Prince de Bulgarie, Mme. Norbert Levavasseur (Baby Rambler), Anny Muller (Pink Baby Rambler), Catherine Zimet (White Baby Rambler), etc.

In Climbing Roses we have a nice stock of Crimson Rambler, Lady Gay, Dorothy Perkins, Dawson, Gardenia, Tausendschon, etc.

LET US KNOW THE QUANTITY YOU WANT AND VARIETIES, AND WE WILL BE GLAD TO QUOTE LOWEST PRICES ON SAME BY RETURN MAIL.

F. R. PIERSON CO., Tarrytown-on-Hudson, New York

two good men to plant, and one at least to pound down. Six or eight men working well together will plant 4000 young plants in a day if the beds are ready prepared. In planting it is well to grade the plants as they are set out of the flats, placing the larger ones in the back row and the smallest in the front. I would not leave too much dish around each plant as with the frequent syringing necessary at this time they collect too much water.

Replanting Old Stock.

In replanting one year or more old stock we use no line or marker but commence at one end of the house digging up, clearing out old loam, throwing in new and resetting at one time. We do not like to do more than necessary of this for it takes five men a month to go through 10,000 square feet of bench and thoroughly overhaul it and costs \$1,000.00. Three years seems to be about the limit of age for profit. It has been said that Richmond should be replanted every year; this is not necessary with us and others report the same. A feature of Richmond is that while grafted stock makes a larger plant in the fall, giving one or two crops before the own root plants come into bearing,

in the middle of winter the self-rooted stock is livelier than the grafted and will throw up long shoots from the bottom four to six weeks earlier than the grafted.

Disposition of the Surplus.

After planting we give a thorough watering around the plant without wetting the whole bed and after that we give no more water for from one to three weeks as the case may require but rely on syringing and cultivating to keep things moving. Keep the soil stirred once a week among newly planted stock. It can be done quicker than the weeds can be pulled out, which come if the soil is not scratched over, and is of incalculable benefit to the plants. As soon as the planting is finished all left over stock can be planted out in the field where it will take care of itself and, unless required, it can be left there until just before the ground freezes in the fall, when it can be brought in and potted or planted thickly on a bench in a cool house, where they will make good plants for Easter or Memorial Day. If lifted about the first of September they will make acceptable plants in pots for Christmas. Liberty makes a splendid rose for this purpose. If established in pots in the summer, treated as a hybrid in early fall, it can be well flowered for Christmas. If needing room now for replanting, any healthy plants to be dug up, if potted, will be fine for Memorial Day. Last year we had 800 plants of Liberty in a house with Brides and 'Maids. They did well up to Christmas, but after that they refused to work. About the first of

March we trimmed the weak wood out of them, and as they grew kept them pinched back until the 15th of April. Between the 15th of May and the 15th of June we cut over 10,000 good flowers from these plants. About eight weeks before Christmas is late enough for the final pinching back for Christmas flowers.

This method of holding back flowers is not so new as some may imagine as it was practiced in the middle west 20 years ago. In regard to drying off plants to be carried over to another year it seems as if more harm is done by too much drying off than otherwise. The beds will dry naturally in the heat of the summer; the wood should never shrivel and foliage should be syringed enough to keep down spiders. This summer treatment is where local conditions and soils call for different treatment.

Syringing.

Syringing is another operation which calls for discretion. Is it paradoxical when we read, do not let roses get soft, and do not let them get hard, in notes written on the subject? The softness to be avoided is of the foliage and young shoots caused by insufficient air, too much fire and syringing:

RHEA REID

READY NOW, Own Root, \$30 per 100, Grafted, \$35 per 100.

AMERICAN BEAUTY

Fine Young Stock, \$6 per 100, \$50 per 1000.

THE E. G. HILL CO., Richmond, Ind.

The Roses that Win

MRS. POTTER PALMER, CARDINAL American Beauty and Other Standard Varieties. Rooted from Our Famous Stock. Send for Prices.

POEHLMANN BROS. CO.
Morton Grove, Ill.

THE BOSTON VIOLET

The people today are looking for New Violets just as much as they are for new roses or carnations.

THE BOSTON VIOLET

For the past two years has been placed before the most sceptical buyers in America and they prefer it to any other.

THERE'S A REASON

The Boston Violet is the largest, the most fragrant, it has a very pleasing color, and it is a great keeper.

THE BOSTON VIOLET

Is a variety that is early grown, it is the strongest grower and is in crop from September to May.

THE BOSTON VIOLET

Was awarded a First Class Certificate of Merit by the Massachusetts Horticultural Society and a Report of Superior Merit by the Gardeners' and Florists' Club of Boston.

Distribution will Commence in April. Order Now.

PRICES—\$2 per 12; \$12 per 100; \$100 per 1000.

WILLIAM SIM, : : CLIFTONDALE, MASS.

the hardness to be guarded against is of the older wood caused by too low a temperature and not enough syringing. How this operation varies with the seasons. Commencing now with the increasing sun and still lots of fire heat at night, evaporation is rapid and good heavy syringings are in order to keep the foliage clean and large. Special attention should be given to ends of benches where pipes may be nearer the plants and dry walks should be damped down every day. If a general syringing is not given every day the plants should at least get a spraying through the bottom from every other walk. I believe in afternoon syringing in the summer time, especially for young and replanted stock. I would not do this later than four o'clock and not on cold or wet days, and would discontinue it as soon as the nights get cool. As the fall approaches it must be done early in the morning so that the plants can dry off before night or mildew and black spots will soon make their appearance. In the winter when the plants will not dry, the syringings have to be cut down to about one a week and even then some varieties have to be shaken to remove the surplus moisture or they remain wet over night. At this time we rely on frequent damping down of the walks and boards, combined with spraying through the bottom of the plants to keep the wood soft and induce it to break. Disbudding is another thing which must be done at the right time. When the plants are growing fast this should be gone over at least every other day.

Mulching is another important matter. Right now is the time to apply a coat, if not already done, if good flowers are wanted for the next three months. I believe that Sept. 1st is late enough to mulch for Christmas flowers. If applied later when the days are shortening it is difficult to dry the plants out and make them break properly. We apply a light dusting of bone flour—about 100 lbs. to 2000 square feet of bench surface—and then, for the same space, from one half to three quarters of a cord of good cow manure chopped up with dry loam and a little lime. In a few weeks this becomes a part of the bed as it will crumble and can be leveled down and is in good condition later to receive liquid manure. If top dressing has to be done later I would lay it in ridges rather than blanket the whole bench with it. We find pails of wood or zinc the handiest things to use for applying top dressing. Here, again, five or six men can work together to good advantage and will cover about 5000 square feet in a day.

Fumigation and Ventilation.

Fumigation must be attended to regularly and the proprietary articles sold are cheaper in the end than the old-fashioned tobacco stems. A little sulphur should always be kept on the pipes to keep down the mildew, always remembering that prevention is better than cure. When flowers are not selling well the plants require particular attention, as poor stock is of no value in a falling market.

Ventilation is of the utmost importance in rose growing. Commencing

now with the warm spring days approaching, a little air should be given early in the morning. Soon the temperature will begin to rise before 7 o'clock and, if air has not been carried all night, the night man can put on a little on his last round. I like to anticipate the rise, and by frequently raising the ventilators a little always keep ahead of the game, and by this method the houses never get so hot in the springtime and the plants are kept healthy and clean. It is important that the houses be kept clean at all times, with no muddy places or water standing in the walks, especially when the firing is reduced to a minimum. The flowers should be cut as early as possible in hot weather and be placed at once in clean water. It is noticeable that every man's stamp is on his own products. A man handling roses in a store can tell you without any distinguishing mark who grew this lot or where these flowers came from.

In conclusion, a few words about the new varieties. It is the part of wisdom to go slow unless you know what they are; descriptions are often misleading, and the only way to find out is by experience. I think that undoubtedly when White Killarney comes on the market, if it proves to be a good shipper, it will be an acquisition, as it possesses the good growing qualities of its sister, Killarney.

In that soft season of descending showers
Call forth the greens, and wake the rising
flowers.
When opening buds salute the welcome
day,
And earth retentive feels the genial ray.
—Pope.

Seed Trade

The bill now before Congress in the interests of pure seeds seems to be attempting the impossible. Absolute purity is something unattainable as to any inert matter and in the case of grass seed, any natural grasses that might spring up spontaneously from the soil might produce seeds so nearly like the variety to be harvested as to make it next to impossible to separate them. For this reason it looks very much as if this bill is so drastic in its character as to defeat its purpose.

A law that is impossible of enforcement manifestly cannot be enforced, and therefore the framers of this particular measure have rather overreached themselves. It seems that certain so-called experts from the Department of Agriculture were before the committee which was framing this bill, presumably for expert advice, but with the exception of Professor W. W. Tracy, not one of the number has ever had any practical experience in the seed business and not one would be employed by a practical seedsmen in the capacity of an expert adviser. The real seedsmen who could have given practical information were not called, but the so-called professors and theorists of the Department were the ones who were asked to advise in the framing of measures to regulate the seed business.

It is quite safe to say that not any important industry could be attacked as the seed business has been in Congress without someone of the members rising in defense of its interests, yet the seed business, important as it is, had not one friend in the House and it may truly be asked, "was there none so poor as to do him (it) honor?" Undoubtedly the explanation of this condition of things is due to the fact that the seedsmen are politically a negligible quantity and do not have to be reckoned with by Congressmen who choose to make footballs of their interests. This is an unfortunate condition of affairs but there is apparently no remedy for it and all the seedsmen can hope for is to appeal to their Senators and Representatives for justice and show them, if they are willing to be shown, the unreasonableness and injustice of hostile legislation.

While this measure is undoubtedly aimed especially at grass seed dealers, as now worded it necessarily affects all seeds and as it is ostensibly in the interests of the farmers, it may be well to show those Congressmen who take such a paternal interest in our agricultural communities, that in the last analysis the farmer will be the man to suffer more than the seedsmen. The former are the men who grow the seed and sell it to the seedsmen and if the bill under consideration should become a law more than 90 per cent. of the grass seed produced would be unsalable as no seedsmen could buy them without risk of incurring the penalties prescribed in the bill.

Doubtless the grass seed dealers have not been as careful about handling adulterated seed as they should have been and have possibly invited the proposed restriction; however, they

should have seen in measures enacted in the past, the trend of events and "the handwriting on the wall."

Of course unless the bill is modified it would never be enforceable and perhaps it might be just as well to permit it to go through Congress and become a law to show our more or less wise solons that in their zeal to aid the farmers they have overdone the business.

Some time ago it was stated in these columns that it looked very much as if Congress would in time pass laws regulating the entire seed trade and this statement was ridiculed by many. The proposed measure seems to be a long step in the direction of government supervision of the seed business and it is difficult to see how it can be interpreted in any other way. This matter will be discussed further in subsequent issues of HORTICULTURE.

This is the busy time for the retail seedsmen and all over the country night work is going on in an effort to keep up with the accumulating business. It is to be hoped that the present activity will continue for the next sixty days at least and, if so, the trade will undoubtedly have had one of the most prosperous years in its history.

Many items are becoming exhausted but it is not quite true as stated in some publications that such varieties of seed corn as Stowell's Evergreen and Country Gentleman are scarcely obtainable at any price; as a matter of fact these items are offered more freely now than two or three months ago. From about the first of February the activity in these lines began to decline and prices to weaken and either of these varieties can now be bought at from \$1 to \$2 per bushel less than on February 1. There is more real scarcity in the early varieties than in the late ones. Good field corn such as Leaming, Pride of the North, Longfellow and Sanford, are very scarce and in some sections these varieties or some of them at least, are selling as high as \$2.50 per bushel with the prediction that they will reach \$3.00. All of the yellow flint varieties are in very short supply and prices are ruling unusually high.

C. C. Morse & Co. are authority for the statement that the California Seed Growers' Co., recently organized at Gilroy, Cal., has been dissolved, by agreement. Ah Him, their Chinese foreman who organized the company, has withdrawn from it and returned to China the 24th ult. for a prolonged visit.

MUSHROOM SPAWN

Michell's English Brand

Used by the leading growers on account of its superior quality. SPECIAL PRICE FOR THIS WEEK ONLY: 12 bricks \$1.40; 100 lbs. \$5; 1000 lbs. \$47.50.

A POINTER → → → Spawn inserted under the sod in lawns and pastures in spring will give a good crop after the fall rains—at almost no expense.

Send for our culture circular. Also Spring Wholesale Catalogue of seeds, etc.

HENRY F. MICHELL COMPANY
1016 Market Street, Philadelphia, Pa.

PLANT IMPORTS.

There were entered at the port of New York during the week March 25th to March 31st, inclusive, the following goods:

From Rotterdam: Amermann & Patterson, 4 cs. plants, 3 cs. trees; U. F. Darrow, 58 es. plants; Wm. Elliott & Sons, 16 es. do., 6 es. trees; Henry & Lee, 37 es. bulbs; McHutchison & Co., 66 es. plants, 6 es. trees; Maltus & Ware, 280 es. plants, etc.; P. Ouwerkerk, 54 es. trees; Palisades Nurseries, 15 es. plants; F. R. Pierson & Co., 15 es. trees; C. L. Richard & Co., 338 es. plants; Stump & Walter Co., 3 es. trees; J. M. Thorburn & Co., 6 es. seed; Vaughan's Seed Store, 2 es. do.; 15 es. plants; Forwarders, 9 es. do., 1 es. bulbs.

From Antwerp: H. F. Darrow, 1 es. bulbs; Maltus & Ware, 80 pgs. trees; Sundry Forwarders, 24 es. plants, 88 pgs. trees, 1 es. bulbs, 6 tubs laurel trees.

Via Glasgow: J. S. Bartle, 57 bags grass seed; Forwarders, 10 pgs. plants.

Via Southampton: C. C. Abel, 27 es. plants; Amermann & Patterson, 6 es. do.; Herman & Patterson, 21 es. do.; August Rolker & Sons, 25 es. do., 1 bale do.; Sundry Forwarders, 4 es. do., 4 cs. plants and trees.

Via Liverpool: McHutchison & Co., 1 es. trees; Maltus & Ware, 4 es. do.; 20 bls. do.; H. S. Peart, 1 es. fruit trees; Forwarders, 4 bls. plants.

From Germany: McHutchison & Co., 22 bds. trees, 8 pgs. do.; Chas. F. Meyer, 1 es. plants; August Rolker & Sons, 5 es. do.; J. M. Thorburn & Co., 9 bls. seed; Vaughan's Seed Store, 1 es. plants; Forwarders, 1 es. trees, 13 baskets do.; To Order, 19 pgs. plants.



Horticultural Products
W. ELLIOTT & SONS, 201 FULTON ST. NEW YORK

What is the best Aster Seed to plant?

Why the very best seed to sow
 Varieties that all should grow
 Kinds that bring to you no woe
 Bear the trade mark "ALTIMO."

Send to-day for As'er Book and Competition Card for the \$250 Prize Aster Growing Contest, Both Free.

ALTIMO CULTURE CO., = CANFIELD, OHIO

PUBLICATIONS RECEIVED.

The Sweet Pea Annual, by Charles H. Curtis and Horace J. Wright. This is the official organ of the National Sweet Pea Society, and is the fourth yearly issue. In every way it is an improvement on former issues. It contains 100 pages with numerous illustrations. Among the articles we notice Mr. Burpee's impressions, Sweet Peas in New South Wales, Sweet Peas in the Antipodes, A Catalogue of Sweet Pea Names, and many others.

The Grand Rapids Greenhouse Co., Grand Rapids, Mich., which was formed some months ago by several of the leading market gardeners of that place, has now contracted for the erection of ten large houses to be located near the present houses of Samuel J. Perry, the general manager. The company is capitalized for \$500,000, and already has an acreage of eight acres.

Vegetable and Flower **SEEDS**
 Reliable and Tested. Catalogue Mailed Free
WEBER & DON
 Seed Merchants
 114 CHAMBERS STREET
 NEW YORK

JUST ARRIVED
 LARGE SHIPMENT OF
High-Grade SCOTCH SOOT.
 We have the Stott Double Nozzle
THOMAS J. GREY CO.
 32 & 33 So. Market St., BOSTON

BRIDGEMAN'S SEED WAREHOUSE
RICKARDS BROS.
 Props.
 37 East 19th St., - NEW YORK CITY

BRASLAN SEED GROWERS CO.
 GROWERS FOR THE
 WHOLESALE TRADE ONLY
SAN JOSE, - - CALIFORNIA

BAMBOO CANES TOUGH AND STRONG
 6 ft. long — \$1 per 100; \$6 per 1000; \$11 per 2000

They cost about 10 per cent. more than other kinds, and they are 10 times better.
STUMPP & WALTER CO., - 50 Barclay St., New York

RELIABLE SEEDS—SOW NOW

Primula Obconica Grandiflora
 new Hybrids as: Blood red, Blue, Carmine, Pink, Purple, Violet, Pure-white, Compacta, Gigantea, Fringed Mixed Hybrids, each separate, Tr. Pkt. 50 cents, 6 Tr. Pkts. \$2.50.
O. V. ZANCEN
 Seedsman. HOBOKEN, N. J.

G. C. MORSE & CO.

Address all communications to our permanent address
 48 to 56 Jackson St., San Francisco, Cal.

The Largest Seed Growers in the United States

BRECK'S SEEDS
 For Farmer, Market Gardener and Florist
 New Crop High Grade
 Catalogues mailed free on application

Joseph Breck & Sons Corp.
 47-54 NO. MARKET ST., BOSTON, MASS.

CAULIFLOWERS SEED
CABBAGE

HJALMAR HARTMANN & CO.,
 12 Stormgade,
 COPENHAGEN, DENMARK.

Burpee's Seeds
 PHILADELPHIA

Blue List of Wholesale Prices mailed only to those who plant for profit

FISKE SEED CO.
 can supply new, to the florist for immediate use.
Aster Seed A Specialty
 Special Florist List Free

H. E. FISKE SEED CO.
 12 & 13 Faneuil Hall Square, BOSTON, MASS.

Look through the Buyers' Directory and Ready Reference Guide. You will find some good offers there also

Thorburn's
Le

COLD STORAGE LILY OF THE VALLEY PIPS

COLD STORAGE LILIUM *Harrisii*, also SPIRAEA GLADSTONE, LILIUM *Auratum*, *speciosum album*, *speciosum rubrum*, Large Flowering Japan Iris, Cannas, etc.

For prices, state quantities required.

J. M. THORBURN & CO.
 33 Barclay St., through to 38 Park Place
 NEW YORK

Best Quality Fall Bulbs

It is to your advantage to place your order early. Send us a list of your wants and we will quote you rock-bottom prices. Copy of our Florists' Bulb Catalogue will be sent upon request. Catalogues now ready.

VICK'S SUPERB PANSY SEED
 All the best varieties in separate colors
 VICK'S SUPERB MIXTURE
 the best strain from all the leading named sorts
 1-8 oz. 75c. 1-4 oz. \$1.50 Ounce \$5.00
JAMES VICK'S SONS, Rochester, N. Y.

CYCLAMEN
Farquhar's Giant Strain

Unsurpassed for size of flowers.
 Giant Crimson Giant Pink
 Giant White Finest Mixed
 Giant Excelsior, White with Claret Base
 100 seeds, \$1.25; 1000 seeds, \$10.00.

R. & J. FARQUHAR & CO.
 6 & 7 So. Market St., Boston, Mass.

QUALITY SEED BULBS PLANTS
 SEND FOR CATALOGUE
ARTHUR T. BODDINGTON
 349 West 14th St., New York.

Easter Lilies \$12.50 per 100 Superb Lily of the Valley \$4 per 100

American Beauties, Richmonds, Killarneys, Brides and Bridesmaids

Violets, Carnations, Daffodils, Tulips, Narcissus, Hyacinths, Sweet Peas, and all seasonable flowers. For Easter decorations: Southern Wild Smilax, Laurel Festooning, Leucothoe Sprays, Hardy Cut Dagger and Fancy Ferns, Bronze and Green Galax.

ALL ORDERS RECEIVE PROMPT AND PERSONAL ATTENTION

HENRY M. ROBINSON & CO.

Telephones
2 17-2618 Main

Wholesale Commission Florists

15 Province St., 9 Chapman Pl.,

BOSTON, MASS.

THE QUALITIES OF FORMOSA LILIES.

Mr. Editor:—Will you please lend your columns to the following question: I notice *Lilium Formosa* advertised as a variety free of disease. To one who has been experiencing these last two seasons the growing deterioration of the Japan longiflorum and multiflorum stocks, this sounds tempting, were it not for the fear that other qualities of this lily may turn out disappointing. May I appeal to such of your readers, who have already tried this lily in previous seasons, to give to their brother florists their experience as to habit of the plants, size and style; also substance of the flowers; whether free flowering, and whether early or late, or easily kept back? Are they fit for pot plants, or only for cut? They must have been tried in this country ere this, possibly for several seasons, sufficiently to allow the claim "entirely free from disease;" but I notice nothing special claimed about other desirable qualities, except to be superior to *Bermuda Harrisii*, a pretty general remark! An open expression on this subject will be thankfully appreciated by the writer and many a lily grower in America.

Editor HORTICULTURE.

Dear Sir:—Answering your correspondent concerning *Formosa* lilies we beg to say that we have about 1000 pots. They are strictly free from disease and we have not thrown away ten plants out of the 1000 pots. They are tall growers with very substantial stems and produce more flowers than any of the other *Longiflorum*s. They can also be forced as early as *Harrisii* lilies but by doing this they may not bloom as large as they ought to. We kept our lilies in the house temperature of 50 to 55 degrees, at night sometimes 60 degrees. We are cutting flowers now. There are about five or six different kinds mixed but the flowers are almost the same, also bloom at the same time. The type of the flowers is rather short but they open up very fine pure waxy white and keep very good. They are good for both pot or cut flowers but if wanted for Easter trade, pot them in the month of November and keep them cool. Yours very truly,

HINODE FLORIST CO.
Whitestone, N. Y.

Dear Sirs:—Replying to "America"

regarding *Lilium Formosa*; we bought a case last fall but did not try to bring them in early as we had a lot of other lilies on hand. The *Formosa* has been in bloom now about six weeks. Some plants measure 30 to 40 inches high, with leaves from the root up and every leaf perfect. They average 5 to 7 flowers to the plant and the flowers stand out firm and stronger than any lilies we ever grew. The flowers have more substance and last longer than any we ever grew. Ours were all pot grown, one bulb in a 6-inch pot and there was not a dwarf or deformed plant in the lot, so they must be free from disease. The plants stand very erect and while the stalk is no larger than other lilies it seems more firm and hard. This year we shall grow them entirely and will try some of them for early, but not for Christmas. They can hardly be classed as a Christmas flower, any more than poinsettias are appropriate for Easter, and when one can have something the year around, like lily of the valley for instance, the novelty wears off.

Yours truly,
Rochester, N. Y. SALTER BROS.

Dear Sir:—In reply to your correspondent, here is our experience with the new *Lilium Formosa*. We grew five thousand of these bulbs the past season. They arrive in this country the latter part of August, but whether they come from the *Formosa* Islands or not, we do not know. We understand these are simply the *Giganteum*, *Longiflorum* and *Multiflorum*, which were moved from the Island of Japan seven years ago by Japanese residents who took up their homes in the Island of *Formosa*. These bulbs after having been planted on fresh soil and in a warmer climate have matured early and so far are free from disease. They come into bloom at about Christmas and are first class in every respect so far as our experience goes though the size of the bulbs was rather small, a good many being from five to six inches in diameter; very few 7-9. We think if the Japanese would be careful to plant their bulbs on new soil each year they would soon get free of disease. Our experience has been limited to one season's growth. We are of course going to try them in larger quantity another year.

Trusting this information is satisfactory, we are, Respectfully,
BASSETT & WASHBURN.
Chicago, Ill.

ANCHUSA ITALICA VAR. DROP-MORE.

None of the varieties of the *Anchorusa* have been planted to any great extent, yet they are exceedingly attractive. The variety above mentioned is one of the latest introductions, and according to European papers was considered one of the best novelties of the season, two years ago.

It is a strong, vigorous grower, with



coarse, dark green foliage and a large branching spike, which last summer grew almost three feet high; so that, with a fairly wet summer it would reach fully four feet. The spike is also nearly three feet wide near the ground.

The flowers commence to open early in July but, like other plants belonging to the borage family, they soon drop; although this debars its use as a cut flower, it does not spoil its use as an ornamental border plant.

The individual flowers are about three-quarters of an inch in diameter, and stay on the spike in full beauty two or three days, but the unopened flower buds are so numerous that the flowering season is from four to six weeks in length.

The exquisite color of the flower is its principle recommendation, being a beautiful shade of deep pure blue.

NEXT WEEK
 Issue of April 11, 1908.
ANNUAL SPRING SPECIAL
 Just the place for your offers of Spring Stock.
PUSH THE EASTER GOODS.

Martial Bremond
 WHOLESALE GROWER OF FRENCH BULBS
 — OLLIOULES, FRANCE —
 A superior quality supplied at market prices. Shipments made direct. Cases marked to order.
 — Sole Agents —
RALPH M. WARD & COMPANY
 12 West Broadway - - NEW YORK

The accompanying cut was taken last summer, and gives a good idea of the habit of the plant.

FREDERIC J. REA.

USEFUL BOOKS.

- We can supply the following books, postpaid, at the prices listed:—
 The Chrysanthemum. Herrington. Price, 50 cts.
 How to Make Money Growing Violets. Saltford. Price, 25 cts.
 Daffodils-Narcissus and How to Grow Them. A. M. Kirby. Price, \$1.10.
 Commercial Violet Culture. Dr. B. T. Galloway. Price, \$1.50.
 Water Gardening. Peter Bisset. Price, \$2.50.
 Lawns and How to Make Them. Leonard Barron. Price, \$1.10.
 Roses and How to Grow Them. By Many Experts. Price, \$1.10.
 The New Cyclopedia of American Horticulture. L. H. Bailey. Four volumes; \$20.00.
 How to Make School Gardens. H. D. Hemenway. Price, \$1.10.
 How to Make a Fruit Garden. S. W. Fletcher. Price, \$2.20.
 How to Plan the Home Grounds. S. Parsons, Jr. Price, \$1.10.
 Soils: How to Handle and Improve Them. S. W. Fletcher. Price, \$2.20.
 The Art of Landscape Gardening, by H. Repton. Price \$3.20, postpaid.
 Water Lilies and How to Grow Them. Henri Huss and H. S. Conard. Price, \$1.21.
 A Plea for Hardy Plants. J. Wilkinson Elliot. Price, \$1.76.
 How to Make a Flower Garden. Price, \$1.76. By Various Experts.
 Ferns and How to Grow Them. G. A. Woolson. Price, \$1.21.
 Chrysanthemum Manual. Smith. Price, 40 cts.

PREPARE FOR EASTER

And buy your plants from the old reliable Wholesale Grower of Easter Plants, Godfrey Aschmann, Philadelphia.

- Easter Lilies, *Lilium multiflorum***, height, 15 to 40 inches, 6-in. pot plants above five buds, 10c. per bud; plants under five buds, 12c. per b'd.
Azalea Indica. Of this fine Easter plant we have an immense stock. Mme. Van der Cruyssen (best double pink), Niebe (double white), Deutsche Perle (double white), Simon Mardner (double pink), Apollo (red), Vervaeana (double rose variegated), Empress of India (double variegated), Prof. Wolters; Schryveriana (dark rose), Bernard Andrea alba, double white, of this variety only large plants, 1.00, 1.25, 1.50, 2.00 each; and many other sorts, price, 60c, 75c, 1.00, 1.25, 1.50 to 2.00 each.
Spiraea Gladstone. Large plants only, full of buds and flowers, 6-in., 50c, 7-in., 75c, to 1.00 each.
Hydrangea Otaksa (pink), 6-7-in., 50c, 75c, 1.00 each.
Primula obconica, 5 1/4-in. 2.00, 2.50, 3.00 per doz.
Cineraria Nyb best strain **Orandiflora**, 5, 5 1/2, 6-in. pots, 2.50, 3.00, 4.00, 5.00 per doz.
Hyacinths, dark blue, light blue, pink and white, 12.00 per 100.
Tournesol Tulips, best double Tulips, 3 bulbs in one pot, 1.50 per doz. pots.
Von Sion Daffodils. Best Yellow Double Narcissus, 5, 5 1/2, 6-in. pots, 3 bulbs in one pot, 2.00, 2.50, 3.00 per dozen pots.
Begonia new Improved Eriardi, 4-in., 20c, 5 1/4-in. 25c
Begonia Flambeau, good seller, 5 1/2-in. 25c, 4-in. 20c.
White Daisies, 5 1/2-in. 25c.
Kentia Belmoreana and Forsteriana, 4-in. 35c, 5 1/2 to 6-in., 50c, 60c, 75c.
Lantana orbonica, 5 1/2-in. 35c.
Ficus Elastica or Rubber Plants, 5 1/2 to 6-in. pots, 40c, 50c.
Ipomoea Multiflora, best pure white Moon Vine, 2 1/2-in. pots, \$5.00 per 100.
Araucaria excels glauca, Specimen Plants, 6 and 7-in. pots, 6 yrs. old, 4-5 tiers, 25-40 inches high, 1.75, 2.00, 2.50, 3.00. Robusta compacta, 7-in., large plants, 30-40 inches, 2.50, 3.00. Excelsa, 4 yrs. old, 6-in. pots, 4-5-6 tiers, 20-30 inches high, 75c, 1.00, 1.25 each; 5 1/2-in. 50c.
 Please mention if plants are to be shipped in or out of pots. Cash with order please. All goods must travel at purchaser's risk. No lites sold by themselves, other plants must accompany the order.

GODFREY ASCHMANN,

1012 West Ontario St., Philadelphia, Pa.

Importer, Wholesale Grower and Shipper of Pot Plants

COLD STORAGE MULTIFLORUM LILY BULBS
 7 to 9s

Delivery immediate or as Ordered. \$45 per 1000

WOOD MOSS, 65c per b'dle.

D. RUSCOVI, 128 W. 6th Street, Cincinnati, O.

In ordering goods please add "I saw it in HORTICULTURE."

FERNS

- Boston, 4 inch 12c, 5 inch 25c.
 Piersonii, 3 inch 8c.
 Eleganti-sima, 2 1/4 inch 6c, 3 inch 10c, 4 inch, 15c.

BAUR FLORAL CO., Erie, Pa.

ORCHIDS

Largest Importers, Exporters, Growers and Hybridists in the World

Sander, St. Albans, England and 235 Broadway, Room 1 NEW YORK CITY

Imported Orchids JUST TO HAND

Laelia Purpurata
Cattleya Intermedia
Cattleya Mossiae

JULIUS ROEHRS CO.,

The Orchid Nurseries RUTHERFORD, N. J.

ORCHIDS

We shall receive in about two weeks' time fine importation of Dendrobium Wardianum, D. Phalaenopsis, D. Formosum giganteum.

April: Most all the Cattleyas, Vandas, Oncidiums, etc. Write for rice List.

GARRILLO & BALDWIN, Secaucus, N. J.

ORCHIDS

The largest importation of Orchids ever received in this country WILL ARRIVE next spring from Brazil, Colombia and Venezuela. If you intend putting in stock wait for these to arrive and we will quote the Lowest Prices in America.

ORDONEZ BROS., - Madison, N. J.

ORCHIDS for Spring Delivery

NEW IMPORTATIONS

Cattleyas, Laelias, Oncidiums, etc.

WRITE FOR PRICES

Now is the time to Pot Orchids. Best Quality of Peat, Moss and Harkets on hand.

JOSEPH A. MANDA, 191 Valley Road, WEST ORANGE N. J.

In ordering goods please add "I saw it in HORTICULTURE."

ORCHIDS

We are at present booking orders for freshly imported Orchids for delivery 1908, of all leading kinds at reduced prices. We have just received the following:— Oncidium Scardeos, O Forbesii, O Tigridium and Sophronites, Grandiflora and Coccinea

LAGER & HURRELL, Summit, N. J.

JAPANESE
 THE YOKOHAMA NURSERY CO. LILIES PLANTS BAMBOO STAKES
 31 BARCLAY STR. NEW YORK.

NEPHROLEPIS SCOTTII

in the following sizes, extra good value

25c., 50c., 75c., and \$1

Grand Specimen Plants at \$3, \$4, \$5, \$6.

JOHN SCOTT

Rutland Road and E. 45th St.

Tel 2890 Bedford BROOKLYN, N. Y.

NEP. WHITMANI

2 1/4 in., \$5.00 per 100

NEP. WHITMANI

3 1/2 in., \$25.00 per 100

BOSTON FERNS

2 1/4 in., \$3.00 per 100

H. H. BARROWS & SON Whitman, Mass.

JOHN BREITMEYER'S SONS

Cor. Miami and Gratiot Aves.
DETROIT, MICH.

Artistic Designs . . .
High Grade Cut Blooms

We cover all Michigan points and good
sections of Ohio, Indiana and Canada

William J. Smyth FLORIST

Cor. Michigan Ave. and 31st St., CHICAGO

We ship to all points in Illinois and Iowa.
Phones: Douglas 744, Douglas 523, Douglas 740

M. C. and J. E. HAUSWIRTH

232 Michigan Ave.
CHICAGO

AUDITORIUM ANNEX Tel. Harrison 585

SAMUEL MURRAY Florist

Coates House Conservatory
1017 BROADWAY, KANSAS CITY, MO
Both Phones 2670 Mafn

FRED C. WEBER FLORIST

4326-28 ST. LOUIS, MO.
OLIVE STREET
Established 1873
Long Distance Phone Bell Lindell 676



GUDE BROS CO
FLORISTS
1214 F ST NW
WASHINGTON DC

WASHINGTON,
D. C.

GUDE'S

Geo. H. Cooke FLORIST

Connecticut Avenue and L Street
WASHINGTON, D. C.

The Park Floral Co.

J. A. VALENTINE
Pres.

DENVER, COLORADO

WILLIAM L. ROCK FLOWER CO.

KANSAS CITY, - MO.

will carefully execute orders for Kansas City
and any town in Missouri or Kansas.

Of Interest to Retail Florists

The long expected decision of Judge Murphy in the case of Knauss vs. Leadley, Detroit, in which the latter sold his flower business to Knauss because of ill health but reopened just a few weeks after the deal was consummated and only two blocks from his old location, has been handed down.

On Oct. 2, 1906, Knauss gave Leadley the Ivanhoe flats worth \$10,000 and \$1500. in cash for the floral business. Leadley had shown books to Knauss to prove that the floral business averaged a profit of \$6500 per year. After Knauss took hold the profits dwindled and the business was run at a loss, and Knauss started suit to recover his flats. Judge Murphy's decision is a vigorous one. It reads as follows:

"In short, without further and wearisome analysis of the testimony, a deliberate swindle has been planned and consummated by the defendant. Indeed his testimony not only brands him as unworthy of belief, but convicted him of wilful falsification on the stand."

The Judge says "that the books were fixed, that expenses were understated and profits overstated. He points out that since Knauss took hold of the floral business it has improved, and that in the trade back Leadley will get a much better business than he had before."

NEWS NOTES.

Fred W. Zeitfuss has started in the florist business at Clarion, Pa.

Hiram Palmer, of Dighton, Mass., has started in the violet growing business.

The Sanborn Florist Co., has started in business at Lakeport, N. H., with H. A. Sanborn as manager.

Mr. Kessler of Kansas City, has taken the position of superintendent of parks at Indianapolis, Ind.

Henry Frueck of Detroit is to try the baths at Carlsbad, Germany, for his health, and intends to leave home about June 1st.

Mrs. Lydia Anger of Fort Wayne, Ind., is arranging to open a branch for Von Bochove & Co., of Kalamazoo, Mich., in connection with her present store.

V. J. Gorley, president of the Grimm & Gorley Florist Co., St. Louis, has purchased the property at 4550-60 St. Louis avenue with greenhouses thereon for \$10,000.

The Rosery on 18th St., Washington, D. C., has been closed for the season. Weiland & Olinger of New Castle, Ind., are preparing to add to their already large range of greenhouses five more of the latest type of construction for carnations exclusively. When these are completed the sixteen houses now standing will be devoted to roses.

Florists Out of Town

Taking orders for delivery in
New York or Vicinity
can have them filled in best
manner and specially deliv-
ered by

Thomas Young, Jr.

500 Fifth Ave., New York City
Telephone 847 Bryant.

ALEX. McCONNELL

571 FIFTH AVENUE
NEW YORK CITY

Telegraphic orders forwarded to any
part of the United States, Canada, and
all principal cities of Europe. Orders
transferred or intrusted by the trade to
our selection for delivery on steamships
or elsewhere receive special attention.

Telephone Calls, 487 and 488 38th St.
Cable Address, ALEXCONNELL

WILLIAM H. DONOHUE

FLORAL DECORATOR

17 East 28th St., New York

Special Attention to Theatre
and Steamer Orders, and reliable
deliveries guaranteed.

DAVID CLARKE'S SONS

Deliver orders from any part of the country to
New York City

Or OUT-GOING STEAMERS

Write or telegraph

2139-2141 Broadway, New York
Telephone 1552-1553 Columbus

M. A. BOWE

In the Heart of New York City

1294 Broadway

Tel. 2270, 38th St. NEW YORK

Our Motto -- The Golden Rule.

YOUNG & NUGENT

42 West 28 St., NEW YORK

"FLOWERS BY TELEGRAPH"

Flower Deliveries

In Brooklyn and other Long Island Points
New York City, New Jersey etc. At Theatres,
Hotels, Steamers or Residences.

WILSON

Fulton St. and Greene Ave., Brooklyn, N.Y.

ALBANY, N. Y.

EYRES

Flowers or Design Work

DELIVERED IN ALBANY AND VICINITY
ON TELEGRAPHIC ORDER.

11 NORTH PEARL ST., ALBANY, N. Y.

JACOB SCHULZ, 644 Fourth Ave.,
LOUISVILLE, KY.

Cut Flowers of BEST QUALITY in season
delivered promptly to any address.

Write, Telegraph or Telephone.
Cumberland and Home Phones 223 and 984

PROMPT DELIVERY IN BOSTON

AND ALL NEW ENGLAND POINTS
HOUGHTON & CLARK
396 Boylston St., Boston, Mass.



BOSTON'S BEST In Quality and Design

Can be relied upon when you transfer your retail orders to

EDWARD MACMULKIN
194 Boylston Street, Boston

Send flower orders for delivery in

BOSTON
and all
NEW ENGLAND POINTS
THOS. F. CALVIN
124 Tremont St., Boston

TRANSFER

Your orders for flower or plant delivery in Eastern New England to

JULIUS A. ZINN,
2 Beacon St., Boston.
Fine Design Work a Specialty

YALE Orders for flower deliveries to Yale College and all other Connecticut points carefully filled and delivered by
J. N. CHAMPION & COMPANY
1026 CHAPEL STREET NEW HAVEN, CONN.

Decorative Plants

By the Load, Delivered and Arranged to Order at Any Address in Chicago and vicinity. Charge for Use, on Application.

GEORGE WITTBOLD CO.
1657 Buckingham Place, Chicago, Ill.

The Far-Famed Flowers of TORONTO

Delivered on mail or telegraph order for any occasion, in any part of the Dominion.

JOHN H. DUNLOP,
96 Yonge St., Toronto, Ont.

ATLANTA FLORAL CO.
41 Peachtree Street, ATLANTA GEORGIA.

EASTER NUMBER
Next Week
ADVERTISE ! ADVERTISE !

HART'S HANDY HANDLE

"At Easter-time, with a little chiffon decoration, and the Handle, we were able to increase the value of plants from 50% to 100%."—H. E. WILSON.

Write for descriptive circular and prices

GEO. B. HART, 24 Stone St., Rochester, N. Y.

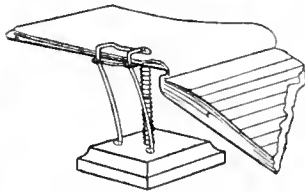

4 in 1
Spring Spindle File and Stenographer's Note Book Holder. Makes no holes in paper; papers can be removed without displacing others; has no sharp point to tear the flesh. Holds note book firmly and at right height for typewriter. Can be used as hat holder, or as support for book to read from. Used by bookkeepers. 50,000 IN USE. Single file 25c postpaid. See large ad. Weekly Board File, page 383, Horticulture, March 21.
A. F. LEWIS MFG CO., E. Boston, Mass.



NEWS NOTES.

Robert Pyle, of the Conard & Jones Co., will be the essayist at the April meeting of the Florists' Club of Philadelphia, which takes place on the 7th inst.

Visitors in Boston: W. C. Langbridge, of J. B. Rice & Co., Cambridge, N. Y.; S. A. Woodrow, New York; J. P. Cleary, New York; F. Lautenschlager, Chicago.

The Park Commission of Northampton, Mass., will plant shrubs in the Main Street Park, to be selected by E. J. Canning. It is said that the complications with the Mague Co. on account of their failure, will be adjusted and F. Mague will carry the work to completion.

HORTICULTURE'S REPRESENTATIVES.

The following named gentlemen represent this paper in their various local districts, and are authorized to accept subscriptions, advertisements and news items:

- BUFFALO, N. Y.—E. C. Brucker, 385-87 Ellicott St.
- CINCINNATI, OHIO—Frank W. Ball, 31 East 3rd St.
- DETROIT, MICH.—Frank Danzer, 1487 15th St.
- INDIANAPOLIS, IND.—George B. Wiegand, 1610 N. Illinois St.
- MINNEAPOLIS, MINN.—C. N. Ruedlinger, 2924 So. Aldrich Ave.
- PHILADELPHIA, PA.—George C. Watson, Dobson Bldg., 9th and Market Sts.
- PITTSBURG, PA.—James Hutchinson, corner Dunmoyle and S. Negley Aves.
- TOLEDO, OHIO.—J. L. Schiller, 929 Prouty Ave.

Again the blackbirds sing; the streams Wake, laughing, from their wintry dreams. And tremble in the April showers The tassels of the maple flowers.
Whittier.

SAVE

your weekly copies of this paper.

DON'T

throw them away.

The contents are always of PERMANENT VALUE and you may need them for reference tomorrow, a year from tomorrow, or still later.

BOSTON FLORIST LETTER CO. Manufacturers of FLORISTS' LETTERS

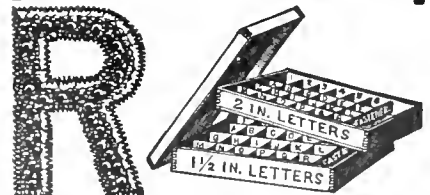

This wooden box nicely stained and varnished, 18x30x12, made in two sections, one for each size letter, given away with first order of 500 letters

Block Letters, 1 1/2 or 2 inch size per 100, \$2. Script Letters, 3. Fastener with each letter or word. Used by leading florists everywhere and for sale by all wholesale florists and supply dealers

N. F. McCARTHY, Manager
66 Pearl Street, BOSTON, MASS.

Large Plants, Bay and Box trees, Palms, Hydrangeas, Agaves, etc., will soon need re-potting. Use the Mission Plant Box if you want the most durable and appropriate box made. Very reasonable in price. Made of pine or cypress

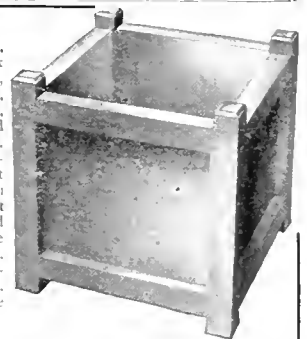

Write for Prices.

Wagner Park Conservatories
SIDNEY, OHIO.

The "Japana" Cut Flower Holder

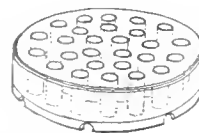

A handy article for florists. Sells to the trade on sight. Made of glass in three sizes. The "Anglais" Table Decoration, something entirely new, long needed. The florist and housewife will appreciate this article, as it simplifies the art of table decorating

Ask for catalog.

M. V. CARNSEY, Dept. A,
130 Waiola Ave., La Grange, Ill.

KORAL SCRIPT LETTERS AND EMBLEMS

ONCE USED ALWAYS USED
For sale by all first class supply houses. Made by

KORAL MFG. CO.
26 Hawley St., Boston

SPECIAL OFFERING for EASTER 1908

Your customers will want plants and flowers for Easter if they do not buy at any other time. Order your supply at once and be ready. We have the finest lot of Easter plants we ever handled. Azaleas, Ramblers, Hydrangeas, Spireas, etc., etc. *Send for Complete Price List.*

LILIES (In Pots). 12 1-2c per bud and flower. Have them shipped early as they carry much better. We handle the crop of the best growers in this locality. Perfect in flower and foliage and the proper height.

RHODODENDRONS. Best value for the money in the market. \$1.50 to \$5.00 each.

Let us have your order for cut Lilies as they promise to be scarce. 12 1-2c and 15c per bud and flower.

S. S. PENNOCK-MEEHAN CO., "THE" Wholesale Florists Philadelphia, Pa.

EVERYTHING SEASONABLE IN
CUT FLOWERS
EDWARD REID, Wholesale Florist
1526 Ranstead St., PHILADELPHIA
STORE CLOSES 8 P. M.

CUT FLOWER BOXES
EDWARDS FOLDING BOX CO
MANUFACTURERS
PHILADELPHIA, PA.

CHAS. W. MCKELLAR

51 WABASH AVE., CHICAGO

Western Headquarters for Choice Orchids
Valley, Roses and all Cut Flowers

PETER REINBERG WHOLESALE

CUT FLOWERS

51 Wabash Av., Chicago, Ill.
In writing advertisers, mention Horticulture

AMERICAN BEAUTY and all other
ROSES
LILY OF THE VALLEY, CARNATIONS
WELCH BROS., 226 Devonshire St., Boston, Mass.

Cut Easter Lilies

Write for Prices

W. E. MCKISSICK WHOLESALE FLORIST
PHILADELPHIA
1619-1621 RANSTEAD ST.

DAILY CONSIGNMENTS

From 40 to 60 Growers

We can care for your cutflower wants to advantage.

E. F. WINTERSON CO.
45-47-49 WABASH AVE., CHICAGO

Rice Brothers

115 N. 6th Street, MINNEAPOLIS, MINN.
WHOLESALE FLORISTS and SUPPLIES
CUT FLOWERS received twice daily, and can fill your orders to your satisfaction. A complete line of Hardy Greens—WILD SMILAX, FOXWOOD, HARDY FANCY FERNS, GALAX LEAVES.
Write for quotations on large quantities.

H. BAYERSDORFER & CO.

The Florists' Supply House of America
Send for Illustrated Catalogue
1129 ARCH ST., PHILA., PA.

ROBERT J. DYSART,
Public Accountant and Auditor
Simple methods of correct accounting especially adapted for florists' use.
Books Balanced and Adjusted
Merchants Bank Building
28 STATE ST., BOSTON
Telephone, Main 58.

WHOLESALE FLOWER MARKETS—TRADE PRICES—Per 100 TO DEALERS ONLY

	CHICAGO March 31	TWIN CITIES March 31	PHILA. March 31	BOSTON April 2
ROSES				
Am Beauty, Fancy and Special...	25.00 to 30.00	45.00 to 60.00	20.00 to 25.00	15.00 to 25.00
" " Ex Ia	16.00 to 20.00	30.00 to 40.00	12.00 to 15.00	10.00 to 15.00
" " No. 1	8.00 to 12.00	15.00 to 25.00	6.00 to 8.00	8.00 to 10.00
" " Lower grades.....	4.00 to 6.00	10.00 to 15.00	3.00 to 5.00	4.00 to 6.00
Bride, Maid, Fancy & Special....	0.00 to 8.00	8.00 to 10.00	8.00 to 10.00	6.00 to 8.00
" " Extra and No. 1	4.00 to 6.00	6.00 to 8.00	4.00 to 6.00	3.00 to 5.00
" " Lower grades.....	2.00 to 4.00	2.00 to 4.00	2.00 to 3.00	1.00 to 2.00
Killarney, Richmond, Fan & Sp....	6.00 to 8.00	8.00 to 10.00	8.00 to 10.00	6.00 to 8.00
" " Lower grades.....	2.00 to 4.00	3.00 to 6.00	3.00 to 5.00	2.00 to 6.00
Chat'nay, Wellesley, Fan. & Sp....	6.00 to 8.00	8.00 to 10.00	8.00 to 10.00	4.00 to 8.00
" " Lower grades.....	2.00 to 4.00	3.00 to 6.00	3.00 to 5.00	1.00 to 3.00
Golden Gate, Ivory.....	4.00 to 6.00	5.00 to 8.00	3.00 to 8.00	1.00 to 6.00
CARNATIONS				
Fancy and Novelties.....	1.50 to 2.00	2.50 to 3.50	3.00 to 4.00	1.00 to 2.00
Ordinary.....	1.00 to 1.50	1.50 to 2.00	1.50 to 2.00	.50 to .75
MISCELLANEOUS				
Violes.....	.25 to .50	.50 to 1.00	.50 to .75	.25 to .50
Cattleyas.....	40.00 to 50.00 to 50.00	50.00 to 60.00	50.00 to 60.00
Cypripediums..... to to to	8.00 to 10.00
Lilies.....	10.00 to 12.00	10.00 to 15.00	12.50 to	6.00 to 10.00
Lily of the Valley.....	2.00 to 3.00	2.00 to 3.50	2.00 to 4.00	1.00 to 2.00
Daisies.....	1.00 to 2.00 to	1.00 to 2.00 to
Daffodils.....	2.00 to 3.00	2.50 to 3.50	1.50 to 2.00	.50 to 1.50
Tulips.....	2.00 to 3.00	2.50 to 3.50	2.00 to 3.00	.50 to 1.50
Mignonette..... to 4.00	4.00 to 6.00	3.00 to 4.00	1.00 to 2.00
Gardenias..... to 25.00	40.00 to 50.00	10.00 to 15.00	25.00 to 45.00
Lilac per bunch..... to 1.00	1.00 to 1.50	.25 to .50	1.00 to 1.50
Sweet Peas.....	.50 to .75 to 1.00	.75 to 1.00	.25 to .50
Adiantum.....	.50 to 1.00	.75 to 1.00	1.00 to 1.50	1.00 to 1.50
Whitmaoii Frods..... to to	3.00 to 5.00	2.00 to 3.00
Smilax.....	10.00 to 12.00	12.00 to 15.00	15.00 to 20.00	10.00 to 12.00
Asparagus Plumosus, strings.....	35.00 to 50.00	35.00 to 50.00 to 50.00	25.00 to 50.00
" " & Spren (roobchs).....	25.00 to 35.00	35.00 to 40.00 to 50.00	1.00 to 50.00

Alex Mann, Jr. Co. Inc.

Wholesale Dealer in
Florists' Supplies and Cut Flowers
White Doves, \$0.00 per doz.
Galax Leaves.
1125 Polk Street, San Francisco, Cal.

J. B. Murdoch & Co.

Wholesale Florists
FLORISTS' SUPPLIES
714 Penn Ave., PITTSBURG, PA.
Long Distance Phone 1435 Court.

E. A. BEAVEN

Southern Wild Smilax,
Log Mosses,
Natural and Perpetuated — at Wholesale,
EVERGREEN, ALABAMA.

H. J. Smith

HARDY CUT FERN
DEALER, ETC.,
Write for Prices
HINSDALE, MASS.

EASTER PLANTS

**Azaleas, Baby Ramblers,
Hydrangeas, Lilies,
Geraniums**

In fine condition. Write for Prices

WM. W. EDGAR CO., Waverley, Mass.

Lilies for Easter CUT AND PLANTS

Prices on application.

We handle the crop of the best growers in this vicinity.

**The Leo Niessen Company
1209 Arch St., Philadelphia, Pa.**

Open from 7 a. m. to 8 p. m.

FLOWER MARKET REPORTS

BOSTON We have little to report as to the conditions in the Boston flower market other than to say that no improvement is yet apparent. If possible, conditions are more unsatisfactory. Roses are coming in very abundantly, but carnations are moderating; still, on account of the slack demand, accumulations are inevitable and the speculator is master of the situation. Growers of bulbous material are warned against ever placing this market in the position it has filled of late; there is no profit in it for them or anybody else.

BUFFALO For the past two weeks the receipts have not been very heavy, though business has slightly improved and the cleaning up at the end of the week has been better than for a few weeks previous. Prices have been low all along the line, especially in violets, carnations and roses. The latter are coming in more abundantly, the quality being good, particularly Carnots and Kaiserins, but the demand is not strong. Beauties dropped in price with the others. As for lily of the valley there has been no demand whatever; the same may be said of gardenias. The Friday special sales have helped to clean up considerable surplus stock at the end of the week. It is hoped that in another week a change for the better will be seen, as for the past week hardly 50 per cent. of the real value was realized.

DETROIT While counter trade cannot be very brisk with Easter so near some relief is expected through the effect of an offcrop on carnations. A very good lot of flowering plants is in view for Easter with a liberal supply of well-budded stocky Harrisii. Carnations are apt to be short.

INDIANAPOLIS The past week has brought quite a decided change in both retail and wholesale circles. There has been quite a generous amount of counter trade and decorative work which has used up lots of stuff. Most of the florists report a fine trade in flowering plants. Excellent Beauties and teas are on the market. Carnations are of good quality, plentiful and cheap. Bulbous stock is to be had

in any quantity at prices below what it ought to be. Lilies are plentiful enough but demand light. Sweet peas, lily of the valley and other stock are moving briskly. Prospects are good for a large supply of everything for Easter.

NEW YORK. As our price quotations fully indicate, New York is still in the dumps as to cut flower trade. The daily avalanche comes in and takes its chances at being moved, that being the main question and the matter of price being entirely subsidiary. This general statement applies practically to the entire list. Cattleyas hold steady at normal figures, but this is true of nothing else in the line of staples.

PHILADELPHIA The hopeful conditions reported a week ago proved transitory and the few warm days played havoc with the situation by forcing in enormous quantities of all kinds of flowers. The demand also slackened up, and present conditions are as bad as they well can be. All roses are fine and plentiful, the colors going rather better than the whites as a rule. Carnations are more sluggish. Sweet peas very good, very plentiful and move better than many other staples. Cattleyas are the only item worth mentioning in orchids and are if anything scarcer. Lily of the valley cleared out a little better but is still far from its standard position. The warm weather has been hard on violets, the singles suffered first; now the doubles are showing symptoms. Daffodils are much in evidence. Easter lilies and callas fair.

WASHINGTON The glut in the cut flower market still continues, though the past few cool days have improved the situation considerably. Several of the local firms have had large orders for decorating for the spring openings. All of the fruit trees are budding, some in full bloom, and all kinds of hardy shrubbery is showing bud and color.

"GRANDMOTHERS' DAY" IN PHILADELPHIA.

Our old favorite, General Jacqueminot, paid a visit to Penneck Bros. this week, in color and sweetness still a "top-notcher." Niphetos and Marechal Neil helped to make an old-time reception lifelike and interesting. The old-fashioned bouquet, bunched up tight like a cauliflower-head, with a paper collar outside, was also in evidence. Mr. Cartledge refused to admit that it was grandmother's day.

BUSINESS CHANGES.

M. Bloy of New Castle, Ind., has purchased the greenhouse business of G. A. Rackham, Detroit, Mich., and will take possession at once.

"Hodgson the Florist," an establishment which for nearly four decades was on Fifth avenue, New York, has closed its recent store at 56th street and its affairs are being conducted from an apartment house in 58th street near Eighth avenue.

INCORPORATED.

East End Floral Co., Memphis, Tenn.; C. Hamner, C. C. Brown, E. G. Bell, M. J. Anderson, W. L. Terry; capital, \$10,000.



Bostrom Improved Builders' Levels and Farm Levels

For Park, Cemetery and Landscape Gardening use, take the place of expensive Engineering Instruments. Simple in construction, easily adjusted, more substantial and less cumbersome than the more elaborate and complicated instruments. Practical, up-to-date instrument that any one can use. Write for descriptive circulars and be convinced that this Level is necessary to complete your outfit. Builders' Level \$25.00. Farm Level \$12.50.

BO-TY OM-BRADY MFG CO., 139 Madison Avenue, ATLANTA, GA.

The KERVAN CO. 113 W. 28th ST. New York

WHOLESALE DEALERS
Fresh cut Palmetto & Cycas Palm Leaves, Galax, Leucothoe, Ferns and Mosses. All Decorating Evergreen.

Prices quoted in these columns are for Dealers Only. When writing to Advertisers Please Mention HORTICULTURE.

JOHN YOUNG
WHOLESALE FLORIST
 Finest American Beauties and
 Carnations
 51 West 28 St. - NEW YORK

FORD BROTHERS
 48 West 28th Street, NEW YORK
FINE ROSES FANCY CARNATIONS
 A Full Line of All CUT FLOWERS
 Telephone, 3870 or 3871 Madison Square

H. E. FROMENT,
 Wholesale Commission Florist,
 Choice Cut Flowers,
 57 West 28th St., :: NEW YORK.
 Telephones: 2200, 2201, Madison Square.

The Reliable Commission House
 Richmond Roses and Rich Flowers
 of all varieties
JOS. S. FENRICH
 110 W. 28th Street, New York
 Tel. 324-325 Madison Square

Established 1891 BUY FROM SHIP TO TRY **ME**
ALFRED H. LANGJAHR
 All Choice Cut Flowers In Season
 55 West 28th St., New York
 Telephone 3924 Madison Square.

JOHN I. RAYNOR
Wholesale Commission Florist SELLING AGENT FOR LARGEST GROWERS
 A full line of Choice Cut Flower stock for all purposes. Comprised a every variety grown for New York market, at current prices
 TEL. 1998 MADISON SQUARE 49 W. 28 St., New York City

Walter F. Sheridan
 Wholesale Commission Dealer in
CHOICE CUT FLOWERS
 39 West 28th Street, New York
 Telephone: 3532-3533 Madison Square

HEADQUARTERS FOR NOVELTIES
ORCHIDS A SPECIALTY
 THE HIGHEST GRADE OF **VALLEY** ALWAYS ON HAND
 GARDENIAS, DAISIES, ROSES AND CARNATIONS
JAMES McMANUS, Telephone 755 Mad. Sq. 42 W. 28th St., New York

PHILIP F. KESSLER 55 & 57 W. 26th St., New York City
 Commission Dealer, Wholesale Buyer and Seller of
 Open from 5 a. m. to 6 p. m. Sunday till 10 a. m. **CUT FLOWERS**
 Tel., 5243 and 2921 Madison Sq. Res., 345 J., Newtown.
Finest Lilies in the Market Every Day in the Year.

WHOLESALE COMMISSION FLORIST **J. K. ALLEN** 106 W. 28 ST. NEW YORK
 Telephone 167 Madison Sq.
 OPEN 6 A.M. DAILY
 We have a good regular outlet for seasonable flowers

NEW YORK QUOTATIONS PER 100—TO DEALERS ONLY

	Last Half of Week ending Mar. 28 1908	First Half of Week beginning Mar. 30 1908		Last Half of Week ending Mar. 28 1908	First Half of Week beginning Mar. 30 1908
Roses			Cattleyas	45.00 to 50.00	40.00 to 50.00
Am. Beauty, Jan and sp.	10.00 to 20.00	10.00 to 20.00	Cypripediums	8.00 to 10.00	8.00 to 10.00
“ extra	5.00 to 8.00	5.00 to 8.00	Lilies	8.00 to 10.00	8.00 to 10.00
“ No. 1	3.00 to 5.00	3.00 to 6.00	Lily of the Valley	1.00 to 2.00	1.00 to 2.00
“ Lower grades to 1.00 to 1.00	Tulips	1.00 to 1.00	1.00 to 1.50
Bride, 'Maid, Jan and sp.	2.00 to 4.00	2.00 to 4.00	Daffodils to 1.00 to 1.00
“ extra	1.00 to 2.00	1.00 to 2.00	Tulips to 1.00 to 1.00
“ lwr. grds. to 1.00 to 1.00	Mignonette to 2.00 to 2.00
Killrauey, Richmond, fancy & spec	2.00 to 4.00	2.00 to 4.00	Gardenias	25.00 to 40.00	25.00 to 40.00
“ lower grades	1.00 to 2.00	1.00 to 2.00	Lilac p r bunch to .50 to .50
Chatenay, Wellesley, Jan, and spec.	2.00 to 4.00	2.00 to 4.00	Sweet Peas50 to .60	.50 to .60
“ lower grades	1.00 to 2.00	1.00 to 2.00	Adiantum75 to 1.00	.75 to 1.00
Golden Gate, Ivory.....	1.00 to 4.00	1.00 to 4.00	Smilax	8.00 to 12.00	8.00 to 12.00
Carnations, Fancy and Novelties.	1.00 to 2.00	1.00 to 2.00	Asparagus Plumosus, strigs.	25.00 to 35.00	25.00 to 35.00
“ Ordinary50 to .75	.50 to .75	“ “ & Spren. (100 bchs.) to 10.00 to 10.00
Violets to .20 to .20			

B. S. SLINN, Jr.
 WHOLESALE FLORIST
 55 & 57 W. 26th St., New York City
 Tel., 3864 Madison Sq. Shipping Orders Solicited.
VIOLETS Roses and Carnations

Edward C. Horan
 Wholesale Florist
 55 WEST 28th ST.
 Tel. 1462 1463 Madison Square New York

TRAENDLY & SCHENCK
WHOLESALE FLORISTS
 Furnish best stock at fair prices all the year round Send for quotations on fall orders
 Tel. 798.799 Madison Sq. 44 West 28th Street, New York City

Alexander J. Guttman
THE WHOLESALE FLORIST OF NEW YORK
 43 WEST 28th STREET
 PHONES. 1664--1665 MADISON SQUARE
ENOUGH SAID



HARDY CUT FERNS

Sphagnum Moss, Extra Large Bales, per bale, \$1.25. Fancy and Dagger Ferns our specialty. A trial order will convince you that we ship only first-class stock. Headquarters for Florists' supplies and wire work. All cut flowers in season. **BOXWOOD**, per bunch 35c, 50 lbs. \$7.50.

MICHIGAN CUT FLOWER EXCHANGE, INC., All 'phone connections 38-40 Broadway, Detroit, Mich.

FANCY and DAGGER
Extra fine, \$1.75 per 1000. Bronze and Green Galax, \$1.25 per 1000. Leucothoe Sprays, \$1.00 per 100, \$7.50 per 1000.

Headquarters in Western New York
FOR
ROSES, CARNATIONS
And all kinds of Seasonable Flowers
Wm. F. Kasting Co.
Wholesale Commission Florist, also Dealer in
Florists' Supplies and Wire Designs.
383-87 ELLICOTT ST.
BUFFALO, N. Y.
Give us a trial. We can please you.

FRANK S. HICKS & CO.
Wholesale Florists.
Open Now for Consignments of Cut Flowers.
52 West 28th Street, - New York City
Tel. 2920 Mad. Sq.

FRANK MILLANG
Wholesale Florist
Telegraphic Orders Filled and Delivered.
55-57 West 26th St., New York City.

Flowers and
Florists' Supplies
The best place in AMERICA to buy
BAY TREES
N. F. McCarthy & Co.
84 Hawley St., BOSTON, MASS.
Large Dealers in Supplies in New England.

HENRY M. ROBINSON & CO.
Wholesale and Commission
FLORISTS
Hardy Cut Evergreens and Florists' Supplies
15 Province St. and 9 Chapman Place,
BOSTON, MASS.

SAMUEL A. WOODROW
WHOLESALE PLANTSMAN
Palms, Large and Small Ferns, etc.
53 West 30th Street, NEW YORK
Telephone 2083 Madison

WILLIAM H. KUEBLER
Brooklyn's Foremost and Best
WHOLESALE COMMISSION HOUSE
A First Class Market for all CUT FLOWERS
28 Willoughby St., Brooklyn, N. Y.
Tel. 4591 Main

CLEARY'S HORTICULTURAL CO.
Management AMBROSE T. CLEARY
Wholesale Contracting, Jobbing, Auction
HORTICULTURAL PRODUCTS
of every description.
Consignments Received. Surplus Stock Converted.
62 Vesey St., NEW YORK

Moore, Hentz & Nash,
Wholesale Commission Florists,
55 and 57 West 26th Street,
Telephone No. 756
Madison Square. **New York.**

WHOLESALE FLOWER MARKETS.— TO DEALERS ONLY. PER 100.

	CINCINNATI March 31	DETROIT March 30	BUFFALO March 30	PITTSBURG March 31
ROSES				
Am. Beauty, Fan, and Sp.....	25.00 to 35.00	25.00 to 35.00	20.00 to 30.00	20.00 to 25.00
“ Extra	15.00 to 25.00	15.00 to 25.00	11.00 to 2.00	10.00 to 15.00
“ No. 1	10.00 to 15.00	0.00 to 15.00	8.00 to 10.00	6.00 to 8.00
“ Lower grades.....	4.00 to 5.00	4.00 to 8.00	3.00 to 8.00	4.00 to 5.00
Bride, 'Maid, F. & S.....	8.00 to 10.00	8.00 to 10.00 to 10.00	8.00 to 10.00
“ Extra	6.00 to 8.00	6.00 to 8.00 to 6.00 to 6.00
“ Low gr.....	3.00 to 4.00	3.00 to 4.00	3.00 to 4.00	2.00 to 4.00
Killarney, Richmond, Fan, & Sp...	8.00 to 10.00	6.00 to 10.00 to 10.00	6.00 to 8.00
“ Lower grades.....	4.00 to 6.00	3.00 to 4.00	3.00 to 6.00 to 4.00
Chatenay, Wellesley, Fan & Sp...	6.00 to 8.00	6.00 to 10.00 to 15.00	6.00 to 8.00
“ Lower grades.....	4.00 to 5.00	3.00 to 4.00	7.00 to 10.00 to 4.00
Golden Gate, Ivory.....	4.00 to 6.00	3.00 to 4.00	3.00 to 8.00 to 6.00
CARNATIONS				
Fancy and Novelties..... to 3.00	2.00 to 1.00	2.00 to 3.00	2.50 to 3.00
Ordinary.....	1.00 to 2.00	1.00 to 1.50	1.00 to 2.00	1.00 to 1.50
MISCELLANEOUS				
Violets.....	.50 to .75	.75 to 1.00	.40 to .75	.25 to .75
Cattleyas.....	40.00 to 50.00	35.00 to 50.00	40.00 to 60.00 to 75.00
Cypripediums..... to to to to
Lilies.....	10.00 to 12.50	12.50 to 15.00	4.00 to 15.00	6.00 to 10.00
Lily of the Valley.....	3.00 to 4.00	2.00 to 4.00	2.00 to 4.00	2.00 to 4.00
Daisies.....	1.00 to 2.00 to to	1.00 to 2.00
Daffodils.....	2.00 to 3.00	2.00 to 3.00	2.00 to 3.00	1.50 to 2.00
Tulips.....	2.00 to 4.00	2.00 to 3.00	2.00 to 3.00	1.50 to 2.00
Mignonette..... to 4.00	4.00 to 8.00	2.00 to 5.00	2.00 to 3.00
Gardenias..... to 25.00	35.00 to 50.00	15.00 to 25.00 to 20.00
Lilac per bunch..... to 1.00 to 1.50	.50 to 1.00	.50 to .75
Sweet Peas.....	.50 to .75	.50 to 1.50	.40 to 1.00	.25 to 1.00
Adiantum..... to 1.00	.75 to 1.50	.50 to 1.00	1.00 to 1.25
Whitmanii Froops..... to to	8.00 to 10.00 to
Smilax.....	10.00 to 12.00	10.00 to 15.00 to 15.00	12.50 to 15.00
Asparagus Plumosus, strings.....	40.00 to 50.00	35.00 to 50.00	40.00 to 60.00	35.00 to 50.00
“ “ & Spren (100 bchs.)	25.00 to 35.00 to 30.00	25.00 to 50.00	20.00 to 50.00

H. C. BERNING
Wholesale Florist
1402 Pine Street, ST. LOUIS, MO.

A. MOLTZ
Will purchase flowers on order in
N. Y. market and ship carefully at
prevailing wholesale prices. Address
55-57 West 26th Street, New York City

MILLANG BROS.
WHOLESALE COMMISSION FLORISTS
41 West 28th Street
Telephone 3860
Madison **NEW YORK**

REED & KELLER
122 West 25th St., New York
Florists' Supplies
We manufacture all our
Metal Designs, Baskets, Wire Work & Novelties
and are dealers in
Glassware Decorative Greens and Florists' Requisites.

In writing to Advertisers kindly mention Horticulture

Buyer's Directory and Ready Reference Guide

Advertisements under this head, one cent a word. Initials count as words.

Regular advertisers in this issue are also listed under this classification without charge. Reference to List of Advertisers will indicate the respective pages.

Buyers failing to find what they want in this list will confer a favor by writing us and we will try to put them in communication with reliable dealers.

ACCOUNTANT

R. J. Dysart, 28 State St., Boston.
For page see List of Advertisers.

ALTERNANTHERAS

Red Alternantheras at 40 cents per 100.
C. W. Moeckel, 17 Summer St., Fitchburg, Mass.

AQUATIC PLANTS

Aquarium plants the year round. Wholesale and retail. Send for price list. Schmid's Emporium of Pets, 712 12th Street, Washington, D. C.

ARAUCARIAS

Godfrey Aschmann, 1012 Ontario St., Philadelphia, Pa.
For page see List of Advertisers.

ASPARAGUS

A. N. Pierson, Cromwell, Conn.
Asparagus Plumosus Seedlings.
For page see List of Advertisers.
Asparagus plumosus and Sprengeri, 2 in., strong, \$2.00 per 100. J. H. Daun & Son, Westfield, N. Y.
Asparagus Plumosa, 2 in. pots. Fine plants, \$3.00 per 100; \$25.00 per 1000. Cash with order or good reference. Erie Floral Co., Erie, Pa.; or Wm. F. Kastling Co., 385 Elliott St., Buffalo, N. Y.

ASPIDISTRAS

Variiegated, 8c. per leaf. Martin Benson, Dongola, Ill.

AUCTION SALES

Cleary's Horticultural Co., 62 Vesey St., New York.
Horticultural Products of Every Description.
For page see List of Advertisers.

Wm. Elliott & Sons, 201 Fulton St., New York.
For page see List of Advertisers.

AZALEAS

A. Leuthy & Co., Perkins St. Nurseries, Roslindale, Mass.
For page see List of Advertisers.
W. W. Edgar Co., Waverley, Mass.
For page see List of Advertisers.
August Rolker & Sons, New York, 31 Barclay St., or P. O. Box 752.
For page see List of Advertisers.
Godfrey Aschmann, 1012 W. Ontario St., Philadelphia.
For page see List of Advertisers.

BAMBOO CANES

Stump & Walter Co., 50 Barclay St., New York.
For page see List of Advertisers.
Yokohama Nursery Co., 31 Barclay Street, New York.
For page see List of Advertisers.

BAY TREES.

N. F. McCarthy & Co., 84 Hawley St., Boston.
For page see List of Advertisers.
Bay Trees and Box Trees, standards and pyramids. All sizes. Price list on application. J. Roehrs Co., Rutherford, N. J.

BEDDING PLANTS

R. Vincent, Jr., & Sons Co., White Marsh, Maryland.
For page see List of Advertisers.
Carlman Rihsam, 31 Wall St., Trenton, N. J.

BEGONIAS

10,000 Begonia Vernon, 2 in., 2c. M. Fenton, West Newton, Pa.
Begonia Pres. Carnot, 2 1/2 in., \$3.00 100. Valley Greenhouse Co., Sewickley, Pa.

BOILERS

BOILERS. "Burubam" Boilers made for greenhouse heating. Lord & Burubam, 1133 Broadway, N. Y.

BOXWOOD

Henry M. Robinson & Co., 15 Province St., Boston.
For page see List of Advertisers.

BUILDING MATERIAL

BUILDING MATERIAL of all description for All Cypress, Seal-iron, Iron Frame or Truss Houses, Hot Red Sash and Frames. Lord & Burubam Co., 1133 Broadway, N. Y.

BULBS AND TUBERS

Joseph Breck & Sons, 47-54 N. Market St., Boston.
For page see List of Advertisers.
J. M. Thornburn & Co., 33 Barclay St., New York.
For page see List of Advertisers.
A. T. Boddington, 342 W. 14th St., N. Y.
For page see List of Advertisers.
Rickards Bros., 37 East 19th St., New York.
For page see List of Advertisers.
H. F. Mitchell Co., Philadelphia.
For page see List of Advertisers.
H. E. Flske Seed Co., Faneull Hall Bq., Boston.
For page see List of Advertisers.
James Vick's Sons, Rochester, N. Y.
Fall Bulbs.
For page see List of Advertisers.
D. Rusconi, 128 W. Sixth St., Cincinnati, O.
Cold Storage.
For page see List of Advertisers.
Aug. Rolker & Sons, 31 Barclay St., New York.
Seasonable Import Plants and Bulbs.
For page see List of Advertisers.
K. Velthuys, Hillegom, Holland.
Represented by Felix Bosch, 260 Clarendon St., Boston.
Bulbs French and Dutch.
For page see List of Advertisers.
Ralph M. Ward & Co., 2 W. Broadway, New York, Agts. for Martial Bremond, Orloules, France.
French Bulbs.
For page see List of Advertisers.
Stump & Walter Co., 50 Barclay St., New York.
Canna Bulbs.
For page see List of Advertisers.
V. H. Hallock & Son, Queens, N. Y.
Lilium Auratum and Double Begonia Bulbs.

CANNAS

The Conard & Jones Co., West Grove, Pa.
For page see List of Advertisers.
J. B. Shurtleff & Son, Cushman Ave., Revere, Mass.
Live Cannas Started from Sand.
For page see List of Advertisers.
Cannas: 6 varieties at \$1.00 per 100; 7 varieties at \$1.25 per 100; 10 varieties at \$1.50 per 100. Our new Dark Pink seedling W. E. Cottrell, the best pink yet, 25c. each; \$2.50 per doz. Frank Cummings Bulb & Plant Co., Meridian, Miss.

CARNATIONS

F. Dornier & Sons Co., Lafayette, Ind.
For page see List of Advertisers.
S. S. Skidelsky, 1741 N. 18th St., Philadelphia.
For page see List of Advertisers.
Chicago Carnation Co., Joliet, Ill.
For page see List of Advertisers.
John E. Haines, Bethlehem, Pa.
Carnations Imperial and Pink Imperial.
For page see List of Advertisers.
Chas. H. Totty, Madison, N. J.
For page see List of Advertisers.

CARNATIONS—Continued

A. N. Pierson, Cromwell, Conn.
For page see List of Advertisers.
White Enchantress, unrooted cuttings. Write for prices. Won first prize for best vase of 50. F. H. Westhoff, De Haven, Pa.
Carnation cuttings of all the leading varieties at the same price as any reliable firm. Write for prices before you look elsewhere. Wm. F. Kastling Co., 383 Elliott St., Buffalo, N. Y.

CHRYSANTHEMUMS

Chas. H. Totty, Madison, N. J.
Single Chrysanthemums.
For page see List of Advertisers.
A. N. Pierson, Cromwell, Conn.
For page see List of Advertisers.
Chrysanthemums. 5000 unrooted cuttings of Yellow Bonnet, 70c. per 100. F. H. Westhoff, De Haven, Pa.
Have 100,000 fine young well-rooted Mums, cuttings of the best 60 commercial varieties. Send for our new and low price list. Satisfaction guaranteed. Wm. F. Fanning, Jr., Coltu, N. Y.
Chrysanthemums ready: 2 1/2 inch strong stock of Touse, Oct. Frost, Polly Rose, Wamamaker, and all standards, \$3 per 100, \$25 per M. New: 2 1/2, strong, Alice Roosevelt, Hankey, Clay Frick, winter Queen, Rosette, B. May, \$5 per 100, \$40 per M. Cash. Send for catalog. Harlowarden Greenhouses, Greenport, N. Y.

COLEUS

Coleus cuttings, 60c. 100; 2 in., 2c. mixed. M. Fenton, West Newton, Pa.
Coleus Golden Bedder, Verschaffeltii, 2 in., \$2.00 100; rooted cuttings, 60c. 100. Valley Greenhouse Co., Sewickley, Pa.
Coleus, Golden Bedder, Verschaffeltii, and mixed Coleus, rooted cuttings, 60c. per 100; \$5.00 per 1000. Cash with order. J. E. Feithousen, Florist, Scenectady, N. Y.

CONIFERS

John Waterer & Sons, Ltd., American Nursery, Bagshot, Eng.
For page see List of Advertisers.
New England Nurseries, Bedford, Mass.
For page see List of Advertisers.

CUT FLOWER BOXES.

Edwards Folding Box Co., Philadelphia.
For page see List of Advertisers.
Folding cut flower boxes, the best made. Write for list. Holton & Hunkel Co., Milwaukee, Wis.

DAHLIAS

David Herbert & Son, Atco, N. J.
For page see List of Advertisers.
J. L. Moore, Northboro, Mass.
For page see List of Advertisers.
Wm. F. Turner & Co., New Bedford, Mass.
Ruth Forbes and Newport.
For page see List of Advertisers.
15,000 Field-grown clumps 2c. and up. List ready. H. W. Koerner, Sta. B, Milwaukee, Wis.

Dahlia Bulbs, 25 choice named varieties, 1-3 Cactus, for \$1. Catalog free. C. Peirce, Dighton, Mass.

Dahlias: About 2000 Cath. Duer, Kriemhilde, Brunhilde, Snowclad, etc., \$3 per 100. Cash. Harlowarden Greenhouses, Greenport, N. Y.

Dahlias. Novelties and standard varieties, true to name, a choice list of the best introductions. Send for catalogue of dahlias, hollyhocks, hardy plants, etc. W. W. Wilmore, Box 382, Denver, Colo.

For List of Advertisers See Page 461

DAHLIAS — Continued

Dahlia Roots—Undivided field clumps, Lyndhurst, Maid of Kent, William Agnew, White Swan, Kreimhilde, John Walker, Arabella and A. D. Livoni. Write for low prices. Wood & Healey, Hammouton, New Jersey.

Cactus, Decorative, Show, Fancy and Pompon Dahlias. 75 leading varieties to select from. Strong divided clumps, in 10 or 20 varieties, my selection at \$3.00 per 100; \$25.00 per 1000. Single Dahlias, mixed, \$1.00 per 100. Cash with order please. Hermann Thiemann, Monson, Mass.

DECORATIVE PLANTS

A. Leuthy & Co., Perkins St. Nurseries, Roslindale, Mass.
For page see List of Advertisers.

EASTER PLANTS

Wm. W. Edgar Co., Waverley, Mass.
For page see List of Advertisers.
A. Leuthy & Co., Perkins St. Nurseries, Roslindale, Mass.
For page see List of Advertisers.
Godfrey Aschmann, 1012 W. Ontario St., Philadelphia.
For page see List of Advertisers.

ENGLISH WALL FLOWERS

Henry A. Dreer, 714 Chestnut St., Philadelphia, Pa.

EUONYMUS RADICANS

Euonymus radicans, 1—1 1/2 ft., \$6.00; 2—2 1/2 ft., \$8.00 per 100. Bushy plants. Brae-Burn Nursery, West Newton, Mass.

EVERGREENS

The New England Nurseries, Bedford, Mass.
For page see List of Advertisers.

FERNS

A. Leuthy & Co., Roslindale, Mass.
For page see List of Advertisers.
H. H. Barrows & Son, Whitman, Mass. Nephrolepis Whitman.
For page see List of Advertisers.
Godfrey Aschmann, 1012 Ontario St., Philadelphia, Pa.
For page see List of Advertisers.
John Scott, Brooklyn, N. Y.
For page see List of Advertisers.
Baor Floral Co., Erie, Pa.
For page see List of Advertisers.

Nephrolepis Exaltata Bostonensis, fine young plants, \$10.00 per 1000.
N. Elegantissima, young plants \$15.00 per 1000. Send for price list. Soar Bros. Little River, Fla.

FERTILIZERS

Polverized Manure Co., 31 Union Stock Yards, Chicago, Ill.
Wizard Brand Cattle Manure.
For page see List of Advertisers.
Thos. J. Grey & Co., 32 and 33 South Market St., Boston. High-Grade Scotch Soot.
For page see List of Advertisers.

FLORAL PHOTOGRAPHS

Floral Photographs. Foley's 226-228 1/2 Bowery, New York.

FLORISTS' LETTERS.

Boston Florist Letter Co., 63 Pearl St., Boston, Mass.
For page see List of Advertisers.
Koral Mfg. Co., 26 Hawley St., Boston.
For page see List of Advertisers.

FLORISTS SUPPLIES

N. F. McCarthy & Co., 84 Hawley St., Boston.
For page see List of Advertisers.
H. M. Robinson & Co., 15 Province St. and 9 Chapman Pl., Boston Mass.
For page see List of Advertisers.
The Keivan Co., 113 W. 28th St., N. Y. Decorative Evergreens.
For page see List of Advertisers.
Reed & Keller, 122 W. 25th St., New York.
For page see List of Advertisers.
J. B. Murdoch & Co., 714 Penn Ave., Pittsburg, Pa.
For page see List of Advertisers.
H. Bayersdorfer & Co., 1129 Arch St., Philadelphia.
For page see List of Advertisers.

FLORISTS' SUPPLIES — Continued

Alex. Mann, Jr., Co., 1125 Polk St., San Francisco, Calif.
For page see List of Advertisers.

FLOWERS BY TELEGRAPH

Park Floral Co., Denver, Colo.
For page see List of Advertisers.
J. N. Champion & Co., 1023 Chapel St., New Haven, Conn.
For page see List of Advertisers.
George H. Cooke, Washington, D. C.
For page see List of Advertisers.
Gude Bros. Co., 1214 F St., Washington, D. C.
For page see List of Advertisers.

Atlanta Floral Co., Atlanta, Ga.
For page see List of Advertisers.

M. C. & J. E. Hauswirth, 232 Michigan Ave., Chicago.
For page see List of Advertisers.

William J. Smyth, Michigan Ave. and 31st St., Chicago.
For page see List of Advertisers.

Jacob Schulz, 644 4th Ave., Louisville, Ky.
For page see List of Advertisers.

Thos F. Galvin, 124 Tremont St., Boston.
For page see List of Advertisers.

Julius A. Zinn, 2 Beacon St., Boston.
For page see List of Advertisers.

Houghton & Clark, 396 Boylston St., Boston.
For page see List of Advertisers.

Sidney Hoffman, 59-61 Massachusetts Ave., Boston.
For page see List of Advertisers.

Edward MacMullin, 194 Boylston St., Boston.
For page see List of Advertisers.

J. Breitmeyer's Sons, Miami and Gratiot Aves., Detroit, Mich.
For page see List of Advertisers.

Samuel Murray, 1017 Broadway, Kansas City, Mo.
For page see List of Advertisers.

Wm. L. Rock Flower Co., 1116 Walnut St., Kansas City, Mo.
For page see List of Advertisers.

Fred C. Weber, 4326-28 Olive St., St. Louis, Mo.
For page see List of Advertisers.

H. G. Eyres, 11 N. Pearl St., Albany, N.Y.
For page see List of Advertisers.

David Clarke's Sons, 2139-2141 Broadway, New York.
For page see List of Advertisers.

W. H. Donohoe, 17 E. 28th St., New York.
For page see List of Advertisers.

Alex. McConnell, New York.
For page see List of Advertisers.

M. A. Bowe, 1294 Broadway, New York.
For page see List of Advertisers.

Robert G. Wilson, Fulton St. & Greene Av., Brooklyn, N. Y.
For page see List of Advertisers.

Thomas Young, Jr., 500 Fifth Ave., N. Y.
For page see List of Advertisers.

Young & Nugent, 42 W. 28th St., N. Y.
For page see List of Advertisers.

FLOWER POTS

W. H. Ernest, 28th and M Sts., Washington, D. C.
For page see List of Advertisers.

A. H. Hews & Co., Cambridge, Mass.
For page see List of Advertisers.

Hilfinger Bros., Ft. Edward, N. Y.
For page see List of Advertisers.

Red pots, seed pans, etc.
The Peters & Reed Pottery Co., Zanesville, O.

FUCHSIAS

Fuchsias, finest mixed, 2 in., \$2.50 per 100; rooted cuttings, \$1.00. Valley Greenhouse Co., Sewickley, Pa.

GALAX

Michigan Cut Flower Co., 38 and 40 Broadway, Detroit, Mich.
For page see List of Advertisers.

GERANIUMS

R. Vincent Jr. & Sons Co., White Marsh, Md.
New and Standard Varieties.
For page see List of Advertisers.
Geraniums, 2-in., double red, \$2.00 per 100. J. H. Dann & Son, Westfield, N. Y.

GERANIUMS — Continued

500 Nutt Geranium Cuttings, \$1.50 per 100, or the lot for \$6.50. C. W. Moeckel, 17 Summer St., Fitchburg, Mass.

Geraniums, Nutt, Castellaine, La Favorite, XX fine, healthy, 2-in. stock, cool grown, not spindled, \$2.00 100, \$17.50 1000. Cash. F. C. Greene, 610 Louis St., Oil City, Pa.

GLADIOLI

Arthur Cowee, Meadowvale Farm, Berlin, New York.
For page see List of Advertisers.
J. L. Moore, Northboro, Mass.
For page see List of Advertisers.
I. & J. L. Leonard, Ioua, N. J. Gladiolus Bulbs.
For page see List of Advertisers.
Gladiol. Write for leaflet. B. Hammond Tracy, Cedar Acres, Wenham, Mass.
Gladiol. Named varieties and mixtures. Send for list. E. E. Stewart, Rivea Junction, Mich.

GLASS

Boston Plate & Window Glass Co., Boston.
For page see List of Advertisers.
Standard Plate Glass Co., 26-30 Sudbury St., Boston.
For page see List of Advertisers.
S. Jacobs & Sons, 1365-79 Flushing Ave., Brooklyn, N. Y.
For page see List of Advertisers.
Panshelsky Bros., 59 Montrose Ave., Brooklyn, N. Y.
For page see List of Advertisers.
Metropolitan Material Co., 1398-1408 Metropolitan Ave., Brooklyn, N. Y.
Foley Mfg. Co., Western Ave., between 25th & 26th Sts., Chicago.
Greenhouse glass, lowest prices. Johnstone Glass Co., Hartford City, Ind.
GLASS, High Grade, Double Thick Greenhouse Glass. Lord & Burnham, 1133 Broadway, N. Y.

GLAZING POINT

H. A. Dreer, Philadelphia, Pa.
For page see List of Advertisers.
GLAZING POINTS, Lord & Burnham Special Glazing Nails (Points). Lord & Burnham, 1133 Broadway, N. Y.

GRAPE DUST

Hammond's Paint & Slug Shot Works, Fishkill-on-Hudson, N. Y.

GREENHOUSE BUILDING MATERIAL.

Lord & Burnham Co., 1133 Broadway, New York.
For page see List of Advertisers.
Pierson U-Bar Co., 1 Madison Sq., N. Y.
For page see List of Advertisers.
A. T. Stearns Lumber Co., Neponset, Boston.
For page see List of Advertisers.
King Construction Co., Tonawanda, New York.
For page see List of Advertisers.
J. C. Moulner Co., 117 East Blackhawk St., Chicago, Ill.
For page see List of Advertisers.

Foley Mfg. Co., Western Ave., between 25th & 26th Sts., Chicago.
For page see List of Advertisers.

I. Cassidy, Summer Ave. and Erie R. R., Newark, N. J.
For page see List of Advertisers.

W. H. Lutton, Jersey City, N. J.
For page see List of Advertisers.

Geo. B. Doane, 18 Midway St., Boston. Iron Pipe.
For page see List of Advertisers.

S. Jacobs & Sons, 1365-79 Flushing Ave., Brooklyn, N. Y.
For page see List of Advertisers.

Metropolitan Material Co., 1398-1408 Metropolitan Ave., Brooklyn, N. Y.

GREENHOUSE CONSTRUCTION

GREENHOUSE CONSTRUCTION, Semi-Iron Greenhouse, New Truss Houses and Iron Frame Houses. Lord & Burnham, 1133 Broadway, N. Y.
J. A. Payne, 260-274 Culver Ave., Jersey City, N. J.
For page see List of Advertisers.

In writing to Advertisers kindly mention Horticulture

GREENHOUSE CONSTRUCTION

Continued

I. Cassidy, Summer Ave. and Erie R. R., Newark, N. J.
For page see List of Advertisers.

Foley Mfg. Co., Western Ave., between 25th & 26th Sts., Chicago.

W. H. Lutton, Jersey City, N. J.
For page see List of Advertisers.

GREENHOUSE HOSE

Mineralized Rubber Co., 18 Cliff St., N. Y.
For page see List of Advertisers.

GUTTERS

OUTTERS, Cast Iron Gutters, L. & B. Improved V Shaped Gutter with drip gutter attachment, Lord & Burnham, 1132 Broadway, N. Y.

HAIL INSURANCE

Florists' Hall Asso. of America.
J. G. Ester, Saddle River, N. J.
For page see List of Advertisers.

HARDY FERNS AND SUPPLIES

H. M. Robinson & Co., 15 Province St. and 9 Chapman Pl., Boston, Mass.
For page see List of Advertisers.

The Keivan Co., 113 W. 28th St., N. Y.
For page see List of Advertisers.

Michigan Cut Flower Exchange, 83 and 40 Broadway, Detroit, Mich.
Fancy Ferns.

For page see List of Advertisers.

H. J. Smith, Hinsdale, Mass.
For page see List of Advertisers.

HARDY PLANTS

Hardy Plants. We have one of the finest assortments of seedlings, transplanted and field-grown stock. Get our prices and descriptions. Moshaek Greenhouse Co., Oaruga, Ill.

Lobelia cardinalis, large clumps, \$1.50 per doz., \$8.00 per 100. Gentiana Andrewsii and linearis, in clumps, \$1.50 per doz., \$8.00 per 100. Native ferns, trees and shrubs at prices to suit. A fine lot of nursery grown White Pine, Hemlock, Fir Balsam, Norway and White Spruce of various sizes at reduced prices. L. E. Williams, Nottingham, N. H.

HART'S HANDY HANDLE

Geo. B. Hart, 24 Stone St., Rochester, N. Y.
For page see List of Advertisers.

HEATING APPARATUS

Lord & Burnham Co., 1133 Broadway, New York.
For page see List of Advertisers.

Pierson U-Bar Co., 1 Madison Sq., N. Y.
For page see List of Advertisers.

John A. Payne, 260-274 Culver Ave., Jersey City, N. J.
For page see List of Advertisers.

HELIOTROPES.

Heliotropes, 2 in., \$2.50 100; rooted cuttings, \$1.00 100. Valley Greenhouse Co., Sewickley, Pa.

HELP FURNISHED

Thos. H. Bambrick, 34 S. 7th St., Phila.
For page see List of Advertisers.

HERBACEOUS PERENNIALS

Red Oak Nurseries, Piskerville, R. I.
For page see List of Advertisers.

HOLLYHOCKS

Hollyhocks, separate colors, field grown, healthy stock, \$3.00 per 100; also Dahlias, novelties and standard varieties. Send for catalogue. W. W. Wilmore, Box 382, Denver, Colo.

HOSE

Frank L. Moore, Chatham, N. J.
Sunnyside Hose.
For page see List of Advertisers.

HOT-BED SASH

The A. T. Stearns Lumber Co., Neposset, Mass.
For page see List of Advertisers.

Pierson U-Bar Co., 1 Madison Sq., N. Y.
For page see List of Advertisers.

Lord & Burnham Co., 1133 Broadway, N. Y.
For page see List of Advertisers.

Foley Mfg. Co., Western Ave., between 25th & 26th Sts., Chicago.

HYDRANGEAS.

HYDRANGEAS PANICULATA.
Grandiflora, 18-in. to 24-in., \$5.00 per 100.
Grandiflora, 2 ft. to 3 ft., \$7.00 per 100.
Grandiflora, 3 ft., \$8.00 per 100.
J. H. Dunn & Son, Westfield, N. Y.

INSECTICIDES.

Nicotinide kills all greenhouse pests
P. R. Palethorpe Co.,
Eleventh St., Owensboro, Ky.
For page see List of Advertisers.

IRISES

Japanese Iris. 25 choicest varieties, large, well rooted divisions, \$10 per 100. Yucca filamentosa, \$15 per 100. T. H. Chivers, Amesbury, Mass.

Iris pallida dalmatica, a beautiful shade of lavender; the largest and most beautiful of all the German Irises; perfectly hardy, and free flowering. One of the good things almost lost to horticulture. \$12.00 per 100; \$100.00 per 1,000. Cash with order. J. A. Peterson, McHenry Ave., Westwood, Cincinnati, O.

JAPANA CUT FLOWER HOLDER

M. V. Garusey, 130 Walola Ave., La Grange, Ill. Dept. A.
For page see List of Advertisers.

KENTIAS

A. Leuthy & Co., Rosendale, Masa.
For page see List of Advertisers.
Godfrey Aschmann, 1012 W. Ontario St., Philadelphia.
For page see List of Advertisers.

LEADING RETAIL FLORISTS

Park Floral Co., Denver, Colo.
For page see List of Advertisers.

George H. Cooke, Washington, D. C.
For page see List of Advertisers.

Gude Bros. Co., 1214 F St., Washington, D. C.
For page see List of Advertisers.

Atlanta Floral Co., Atlanta, Ga.
For page see List of Advertisers.

M. C. & J. E. Hauswirth, 232 Michigan Ave., Chicago.
For page see List of Advertisers.

William J. Smyth, Michigan Ave. and 31st St., Chicago.
For page see List of Advertisers.

Jacob Scholz, 644 4th Ave., Louisville, Ky.
For page see List of Advertisers.

Thos. F. Galvin, 124 Tremont St., Boston.
For page see List of Advertisers.

Julius A. Zinn, 2 Beacon St., Boston.
For page see List of Advertisers.

Houghton & Clark, 396 Boylston St., Boston.
For page see List of Advertisers.

Sidney Hoffman, 59-61 Massachusetts Ave., Boston.
For page see List of Advertisers.

Edward MacMulkh, 194 Boylston St., Boston.
For page see List of Advertisers.

J. Breitmeyer's Sons, Detroit, Mich.
For page see List of Advertisers.

Sammuel Murray, 1017 Broadway, Kansas City, Mo.
For page see List of Advertisers.

Wm. L. Rock Flower Co., 1116 Walnut St., Kansas City, Mo.
For page see List of Advertisers.

Fred C. Weber, 4326 Olive St., St. Louis, Mo.
For page see List of Advertisers.

J. N. Champlin & Co., 1026 Chapel St., New Haven, Conn.
For page see List of Advertisers.

H. G. Eyres, 11 N. Pearl St., Albany, N. Y.
For page see List of Advertisers.

David Clarke's Sons, 2139-2141 Broadway, New York.
For page see List of Advertisers.

W. H. Donohoe, 17 E. 28th St., New York.
For page see List of Advertisers.

Alex. McConnell, New York.
For page see List of Advertisers.

M. A. Bove, 1294 Broadway, New York.
For page see List of Advertisers.

Robert G. Wilson, Fulton St. and Greene Ave., Brooklyn, N. Y.
For page see List of Advertisers.

Thomas Young, Jr., 500 Fifth Ave., N. Y.
For page see List of Advertisers.

LEADING RETAIL FLORISTS

Continued

Young & Nugent, 42 W. 28th St., N. Y.
For page see List of Advertisers.

MISCELLANEOUS PLANTS.

Coleus, 10 varieties, 2-in., 1 1/2-c. Nasturtiums, double red and yellow, 2-in., 1 1/2-c.; rooted cuttings, 75c. Gnaphallum, rooted cuttings, 75c. 100. Tradescantia tricolor, rooted cuttings, 75c. Geraniums, 2-in. Trego, Vland, Buchner, Henderson, \$2 100. Sallerol, 2-in., \$1.50. J. F. Sked, Westerville, Ohio.

NEW AND RARE PLANTS

Roe Hill Nurseries, New Rochelle, N. Y.
For page see List of Advertisers.

MISSION PLANT BOX

Wagner Park Conservatories, Sidney, O.
For page see List of Advertisers.

NICO-FUME

Kentucky Tobacco Product Co., Louisville, Ky.

NURSERY STOCK

John Waterer & Sons, Ltd., American Nursery, Bagshot, England.
For page see List of Advertisers.

New England Nurseries, Bedford, Mass. Shrubs, Roses and Herbaceous Perennials. Specimen Pyramidal Box.
For page see List of Advertisers.

Bay State Nurseries, N. Abington, Mass. Herbaceous Perennials, Hardy Ornamental Trees.
For page see List of Advertisers.

Cleary's Horticultural Co., 62 Veasey St., New York.
For page see List of Advertisers.

P. Ouwerkerk, 216 Jane St., Weehawken Heights, N. J.
Holland Nursery Stock for Forcing.
For page see List of Advertisers.

American Nursery Co., 150 Broadway, New York, N. Y.
For page see List of Advertisers.

I. & J. L. Leonard, Iona, N. J. California Privet, American Chestnuts.
For page see List of Advertisers.

L. L. May & Co., St. Paul, Minn. Shrubs, Roses, Small Fruits, Ornamental and Fruit Trees.
For page see List of Advertisers.

D. J. Twomey, Dept. H., Geneva, N. Y. Trees and Plants.
For page see List of Advertisers.

Carlman Ribsam, 31 Wall St., Trenton, N. J.
California Privet, Trees, Shrubs, Etc.
For page see List of Advertisers.

The Morris Nursery Co., Sales Office, 1 Madison Ave., New York. Ornamental Trees, Evergreens, Hedge Plants.
For page see List of Advertisers.

Peter's Nursery Co., Knoxville, Tenn. Live Fences; Amoor and California Privet.
For page see List of Advertisers.

P. J. Berckmans Co., Fruitland Nurseries, Augusta, Ga.
Biota Aurea Nana.
For page see List of Advertisers.

NURSERY STOCK.

Per 100
2,500 Berberis Thunbergii, 2 to 3 ft., \$9.00
1,000 Cornus Spathulifolia, golden, 1 1/2 to 2 ft. 10.00
1,000 Cydonia Japonica, 2 1/2 to 3 ft. 9.00
500 Dentzia Pride of Rochester, 10.00
500 Forsythia in 3 varieties, 10.00
500 Hydrangea Pan. grand., 10.00
10,000 Ligustrum Itoha, 2 1/2 to 3 ft., 8.00
1,000 Crimson Ramblers, 2 yrs., 9.00 & 10.00
1,000 Dorothy Perkins, 2 yrs., 9.00 & 10.00
Rhododendrons, Azaleas, etc. etc.
The Continental Nurseries, Franklin, Mass.

ORCHID PLANTS

Lager & Hurrell, Summit, N. J.
For page see List of Advertisers.

Sander, St. Albans, England. Importers, Exporters, Growers, Hybridists
For page see List of Advertisers.

Julius Roehrs Co., Rutherford, N. J.
For page see List of Advertisers.

Carrillo & Baldwin, Secaucus, N. J.
For page see List of Advertisers.

ORCHID PLANTS—Continued

Jos. A. Manda, 191 Valley Road, W. Orange, N. J.
For page see List of Advertisers.

Ordonez Bros., Madison, N. J., Box 105.
For page see List of Advertisers.

PALMS

A. Leuthy & Co., Perkins St. Nurseries, Roslindale, Mass.
For page see List of Advertisers.

Robert Craig Co., Market and 49th St., Philadelphia, Pa.
For page see List of Advertisers.

Kentia, Phoenix, etc., all sizes. Write for new price list. Julius Roehrs Co., Rutherford, N. J.

PAINT AND PUTTY

PAINT AND PUTTY: Ideal Greenhouse lead; Special Greenhouse Putty. Lord & Burnham, 1135 Broadway, N. Y.

PANSY PLANTS.

Choice pansy plants, 50c. per 100; \$4.00 per 1000. Cnsh. Aug. Zirngelbel, Needham, Mass.

Pansy Plants. From extra selected seed. Fall seedlings \$3.50 per 1000. Fall transplanted \$6.00 per 1000. Large plants \$10.00 per 1000. Mosbaek Greenhouse Co., Onarga, Ill.

PATENTS

Siggers & Siggers, Washington, D. C.
For page see List of Advertisers.

PEAT

Orchid peat, Rotted peat, Azalea peat, Leaf-Mould, Live Sphagnum moss, Baled Sphagnum moss, Green Clump moss, etc. Jobbers' list on application. C. W. Brownell & Co., Waldeu, N. Y.

PEERLESS PLANT FOOD

Henry A. Dreer, 714 Chestnut St., Phila.

PELARGONIUMS

R. Vincent, Jr. & Sons Co., White Marsh, Maryland.
For page see List of Advertisers.

PEONIES

Wholesale Peony list for fall 1908 is now ready. J. F. Rosenfield, West Point, Neb.
One of the finest collections in America. Send 25 cts. in stamps for new edition of Peony Manual. C. S. Harrison's Select Nursery, York, Neb.

PHLOXES

Send 25 cts. in stamps for Phlox Manual. Fine mixed phloxes \$1.50 per 100. C. S. Harrison's Select Nursery, York, Neb.

PIPE AND FITTINGS

Foley Mfg. Co., between Western Ave. and 26th St., Chicago, Ill.

Eagle Metal & Supply Co., Johnson and Union Aves., Brooklyn, N. Y.
Second-Hand Pipe and Boiler Tubes.
For page see List of Advertisers.

PIPE AND FITTINGS. Cast Iron and Wrought Pipe, Valves, Elbows, Pipe Hooks, Automatic Air Henders, etc. Lord & Burnham, 1133 Broadway, N. Y.

PLANT BED CLOTH

Mineralized Rubber Co., 18 Cliff St., N. Y.
For page see List of Advertisers.

PLANT STAKES AND TRELLISES

Seele's Patent, for roses, chrysanthemums, gladioli, tuberoses, dahlias, tomatoes, egg plants, etc. H. D. Seele & Sons, Mfg., Elkhart, Ind.

POT HANGERS

Pot hangers, Kramer's \$1 doz. by exp. \$1.25 by mail. J. N. Kramer & Son, Cedar Rapids, Ia.

PRIVET

Golden Glory, magnificent golden leaf, \$5.00 per 100. Martin Benson, Dougola, Ill.

RAFFIA

Raffia (colored), 20 beautiful shades. Samples free. R. H. Conroy Co., Camden, N. J.; 810 Washburn Ave., Chicago, Ill.

RHODODENDRONS

John Waterer & Sons, Ltd., American Nursery, Bagshot, England.
For page see List of Advertisers.

P. Ouwerkerk, Hoboken, N. J.
For page see List of Advertisers.

ROSES

Julius Roehrs Co., Rutherford, N. J.
Rambler Rose, Newport Fairy.
For page see List of Advertisers.
New England Nurseries, Inc., Bedford, Mass.
For page see List of Advertisers.

Bay State Nurseries, N. Abington, Mass.
For page see List of Advertisers.

Ellwanger & Barry, Rochester, N. Y.
Hardy Roses.
For page see List of Advertisers.

Robert Craig Co., Market and 49th St., Philadelphia, Pa.
For page see List of Advertisers.

Dingee-Conard Co., West Grove, Pa.
New Climbing Rose, Tausendschon.
For page see List of Advertisers.

The Morris Nursery Co., Sales Office, 1 Madison Ave., New York.
Ornamental Trees, Evergreens, Hedge Plants.
For page see List of Advertisers.

Montrose Greenhouses, Montrose, Mass.
Grafted Stock Bride, Bridesmaid, Killarney.
For page see List of Advertisers.

F. R. Pierson Co., Tarrytown-on-Hudson, N. Y.
Hardy Roses for the Garden.
For page see List of Advertisers.

R. & J. Farquhar & Co., 6 and 7 South Market Street, Boston.
For page see List of Advertisers.

400 varieties; own roots; summer grown. Leedle Company, Springfield, Ohio.

M. H. Walsh, Woods Hole, Mass.
Roses that bloom from June to November.

Roses, Maid, Bride, Chateau, Gate, 2 in., \$3.00 100. Valley Greenhouse Co., Sewickley, Pa.

Crimson Ramblers, 2 year, on own root, extra strong, at 7 cents. Gilbert Costich, Rochester, N. Y.

Low-budded roses, No. 1, \$95.00; No. 112, \$65.00 1000. H. T. Jones, Elizabeth, N. J.

The beautiful new pink rose, MISS KATE MOULTON is the queen of all pink roses. It's a winner and you should grow it. Price \$30.00 100; 500 \$125.00; 1000 \$200.00; 5000 and upwards \$175 per 1000. Minneapolis Floral Co., Minneapolis, Minn.

SAGE PLANTS

Good thrifty sage plants from 2-inch pots, \$1.50 per 100; ready now. Cash with order. Virginia Nursery Co., Purcellville Va.

SEEDS

T. J. Grey Co., 32 So. Market St., Boston, Mass.
For page see List of Advertisers.

Joseph Breck & Sons, 51 and 52 N. Market St., Boston, Mass.
For page see List of Advertisers.

W. Atlee Burpee & Co., Philadelphia.
For page see List of Advertisers.

J. M. Thorburn & Co., 33 Barclay St., N. Y.
For page see List of Advertisers.

A. T. Boddington, 342 W. 14th St., N. Y.
For page see List of Advertisers.

H. F. Mitchell Co., 1017 Market St., Phila.
For page see List of Advertisers.

James Vick's Sons, Rochester, N. Y.
Vick's Superb Pansy Seed.
For page see List of Advertisers.

Hjalmar Hartmann & Co., 12 Stormgade, Copenhagen, Denmark.
Cauliflower and Cabbage Seed.
For page see List of Advertisers.

Richard Bros., 37 E. 19th St., New York.
For page see List of Advertisers.

R. & J. Farquhar & Co., 67 So. Market St., Boston.
Giant Cyclamen Seed.
For page see List of Advertisers.

C. C. Morse & Co., 48-56 Jackson St., San Francisco, Cal.
For page see List of Advertisers.

SEEDS—Continued

H. E. Flske Seed Co., Faneuil Hall Sq., Boston.
Aster Seed.
For page see List of Advertisers.

Branlan Seed Growers Co., San Jose Cal.
For page see List of Advertisers.

O. V. Zangen, Hoboken, N. J.
For page see List of Advertisers.

Stumpp & Walter Co., 50 Barclay St., New York.
For page see List of Advertisers.

Weeber & Dou, 114 Chambers St., New York.
For page see List of Advertisers.

Altimo Culture Co., Canfield, O.
Aster Seed.
For page see List of Advertisers.

Asparagus Pl. Nanus, \$2.50 per 1000. Plant early. Asparagus Plants 14 to 18 inches high, \$6 per 100. Peter Mack, Box 172, Orlando, Fla.

Davis Perfect and Burrell's Klondike Cucumber Seed, 85c. per pound. Finest slicing varieties grown. D. V. Burrell, Rocky Ford, Colorado.

SEEDS SEEDS SEEDS

Buckbee's Famous "Full of Life" Pedigreed strains of the newest and best varieties vegetable and flower seeds, etc. If you have failed to receive a copy of our Spring Trade List write for it today.

H. W. BUCKBEE, Rockford, Illinois. Rockford Seed Farms. Forest City Greenhouses.

ASTER SEEDS:—All Full Weight Packets Fertile 1907 Crop. EXPRESS,—White, Violet, Rose. Trade Packet 1-16 oz., 25c.; 1-4 oz., 75c.; ounce, \$2.50. QUEEN OF MARKET,—White, Lt. Pink, Rose, Lavender, Purple. Trade Packet 1-8 oz., 10c.; 1-4 oz., 15c.; ounce, 50c. LATE BRANCHING,—White, Pink, Rose, Lavender, Purple. Trade Packet 1-8 oz., 20c.; 1-4 oz., 30c.; ounce, 80c. CARLSON'S BRANCHING,—Pink, Lavender, Early and Late White. Trade Pkt. 1-8 oz., 25c.; 1-4 oz., 40c.; ounce, \$1.25. KATE LOCK,—White, Daybreak. Same price as Branching. ROYAL PURPLE,—Trade Pkt. 1-16 oz., 35c.; 1-4 oz., \$1.00; ounce, \$3.00. VIOLET KING,—Trade Pkt. 1-8 oz., 30c.; 1-4 oz., 50c.; ounce, \$1.50.

Many Other Standard Sorts in Limited Quantity. Write if interested. ELMER D. SMITH & CO., Adrian, Mich.

SMILAX

E. A. Beaven, Evergreen, Ala. Southern Wild Smilax; Log Mosses.
For page see List of Advertisers.

Vern L. Schluraff, Erie, Pa.
Smilax, nice young plants, fall sown, 50c. per 100; \$4.00 per 1000. F. A. Baller, Bloomington, Ill.

SPHAGNUM MOSS

Live Sphagnum moss, orchid peat and orchid baskets always on hand. Lager & Hurrell, Summit, N. J.

For a high grade Sphagnum and Green Decorating Moss, different grades of Peat, write for prices and samples. We can give best satisfaction as our stock is well cleaned, well packed. Prompt attention given. American Moss & Peat Co., Box 6, Waretown, N. J.

SPRAYERS

Charles J. Jager Co., 251-85 Franklin St., Boston.
For page see List of Advertisers.

SQUABS

Jno. A. Kepner, Harrisburg, Pa., Box 3.
For page see List of Advertisers.

STRAWBERRY PLANTS

M. Crawford Co., Cuyahoga Falls, O.
New Strawberry, The Highland.

Strawberry plants and Asparagus roots (50 varieties). Catalog free. C. Peirce, Dighton, Mass.

STEAM TRAP

E. Hippard, Youngstown, O.

In writing to Advertisers kindly mention Horticulture

VEGETABLE PLANTS

Horse radish sets Extra fine stock, \$2.50, \$3.50, \$4.50 per 100. Mosbuck Greenhouse Co., Oxnarda, Ill.

VENTILATING APPARATUS

Pierson U-Bar Co., 1 Madison Sq., N. Y.
For page see List of Advertisers.

Foley Mfg. Co., Western Ave., between 25th & 28th Sts., Chicago.
For page see List of Advertisers.

John A. Payne, 290-274 Culver Ave., Jersey City, N. J.
For page see List of Advertisers.

The Advance Co., Richmond, Ind.
For page see List of Advertisers.

VENTILATING MACHINERY. New Model encased, self-oiling gear; Standard Model Open Gear. Lord & Burham, 1133 Broadway, N. Y.

VINCAS

J. J. Arnold, Homer, N. Y.
For page see List of Advertisers.

VIOLETS

William Sim, Cliftondale, Mass.
Violet Boston.
For page see List of Advertisers.

Prince of Wales Violet Clumps, \$5.00 per 100. Joy Floral Company, Nashville, Tenn.

Violets for sale. Well rooted divisions of Princess of Wales, or would exchange for rooted carnation cuttings of Pink Lawson or Queen. Albion D. Emerson, Westville, N. H.

Violet cuttings, "Marla Louisa" Rhinebeck stock, rooted runners, May delivery \$20.00 M. Immediate delivery, between now and March 15th, \$10.00 M. Wm. F. Kasting Co., 383 Ellicott St., Buffalo, N. Y.

WEEKLY BOARD FILE

A. F. Lewis Mfg. Co., E. Boston, Mass.
For page see List of Advertisers.

WIREWORK

Reed & Keller, 122 W. 25th St., N. Y.
For page see List of Advertisers.

Wirework. Write for our catalogue. Holton & Hunkel Co., Milwaukee, Wis.

William E. Heilscher's Wire Works, 38-40 Broadway, Detroit, Mich.

The "Just Right" kind. Send for price list. Frank W. Bail, 31 East Third Street, Cincinnati, O.

WOOD MOSS

D. Rusconi, 128 W. 6th St., Cincinnati, O.
For page see List of Advertisers.

WHOLESALE FLORISTS**Boston**

N. F. McCarthy & Co., 84 Hawley St., Boston.
For page see List of Advertisers.

H. M. Robinson & Co., 15 Province St. and 9 Chapman Pl., Boston.
For page see List of Advertisers.

Welch Bros., 226 Devonshire St., Boston.
For page see List of Advertisers.

Buffalo

Wm. F. Kasting Co., 383-87 Ellicott St., Buffalo, N. Y.
For page see List of Advertisers.

Chicago

Chas. W. McKellar, 51 Wabash Ave., Chicago.
For page see List of Advertisers.

Peter Reinberg, 51 Wabash Ave., Chicago.
For page see List of Advertisers.

E. F. Winterson Co., 45-49 Wabash Ave., Chicago.
For page see List of Advertisers.

Detroit

Michigan Cut Flower Exchange, 38 and 40 Broadway, Detroit, Mich.
For page see List of Advertisers.

WHOLESALE FLORISTS—**Continued
Minneapolis**

Rice Bros., 115 N. 6th St., Minneapolis, Minn.
For page see List of Advertisers.

New York

J. K. Allen, 106 W. 28th St., New York
For page see List of Advertisers.

J. S. Fenrich, 110 W. 28th St., New York.
For page see List of Advertisers.

Ford Bros., 48 W. 28th St., New York
For page see List of Advertisers.

H. E. Froment, 57 W. 28th St., New York.
For page see List of Advertisers.

Alex. J. Guttman, 43 W. 28th St., New York.
For page see List of Advertisers.

E. C. Horan, 55 W. 28th St., New York
For page see List of Advertisers.

A. H. Langjahr, 55 W. 28th St., New York.
For page see List of Advertisers.

James McManus, 42 W. 28th St., New York
For page see List of Advertisers.

John I. Raynor, 49 W. 28th St., New York.
For page see List of Advertisers.

W. F. Sheridan, 39 W. 28th St., New York
For page see List of Advertisers.

Traendly & Schenck, 44 W. 28th St., New York.
For page see List of Advertisers.

John Young, 51 W. 28th St., New York.
For page see List of Advertisers.

Moore, Hentz & Nash, 55 and 57 W. 28th St., New York.
For page see List of Advertisers.

Frank S. Hlicka & Co., 52 W. 28th St., New York.
For page see List of Advertisers.

Frank Millang, 57 W. 26th St., New York.
For page see List of Advertisers.

Wm. H. Kuebler, 28 Willoughby St., Brooklyn, N. Y.
For page see List of Advertisers.

Phillip F. Kessler, 55 and 57 W. 26th St., New York.
For page see List of Advertisers.

A. Moltz, 55-57 W. 26th St., New York.
For page see List of Advertisers.

B. S. Sinn, Jr., 55 W. 26th St., New York.
For page see List of Advertisers.

Millang Bros., 41 W. 28th St., New York.
For page see List of Advertisers.

Philadelphia

W. E. McKissick, 1619-1621 Ranstead St., Philadelphia, Pa.
For page see List of Advertisers.

Leo Nissen Co., 1209 Arch St., Philadelphia, Pa.
For page see List of Advertisers.

The S. S. Pennock-Meehan Co., 1608-18 Ludlow St., Philadelphia, Pa.
For page see List of Advertisers.

Edward Reid, 1526 Ranstead St., Philadelphia, Pa.
For page see List of Advertisers.

Pittsburg

J. B. Mndoch & Co., 714 Penn Ave., Pittsburg, Pa.
For page see List of Advertisers.

San Francisco

Alex. Mann, Jr., Co., 1125 Polk St., San Francisco, Cal.
For page see List of Advertisers.

St. Louis

H. G. Berning, 1402 Pine St., St. Louis, Mo.
For page see List of Advertisers.

WHOLESALE PLANTSMAN

Samuel A. Woodrow, 53 W. 30th St., New York.
For page see List of Advertisers.

New Offers in This Issue.

BUILDERS' AND FARM LEVELS.
Bostrom-Brady Mfg. Co., 139 Madison Ave., Atlanta, Ga.
For page see List of Advertisers.

DAHLIAS.

Henry A. Dreer, 714 Chestnut St., Philadelphia.
For page see List of Advertisers.

FLOWERS FOR EASTER.

H. M. Robinson & Co., 15 Province St., Boston.

KEYSTONE CEDAR PLANT TUBS.

Henry A. Dreer, 714 Chestnut St., Philadelphia.
For page see List of Advertisers.

LAWN VASES.

Kramer Bros. Fdy. Co., Dayton, Ohio.
For page see List of Advertisers.

PLANT DECORATIONS BY TELEGRAPH.

George Wittbold Co., 1657-59 Buckingham Place, Chicago.
For page see List of Advertisers.

RETAIL FLORIST.

J. H. Dunlop, 96 Yonge St., Toronto, Can.
For page see List of Advertisers.

ROSES, RHEA REID, AMERICAN BEAUTY.

The E. G. Hill Co., Richmond, Ind.
For page see List of Advertisers.

ROSES THAT WIN.

Pochlmann Bros. Co., Morton Grove, Ill.
For page see List of Advertisers.

Anything of Value

to the profession

CAN BE SOLD

through advertising in

Horticulture

List of Advertisers

Page	Page
Advance, The Co. 403	Manda Jos. A. 449
Allen J. K. 454	Mann, Alex Jr. Co. 452
Altum Culture Co. 447	MacMullen F. A. 456
American Nursery 436	May L. L. & Co. 456
Amerian Nursery Co. 436	McCarthy N. F. & Co. 455
Arnold J. J. 435	McConnell Alex. 450
Aschmann G. 449	McKellar Charles W. 452
Atlanta Floral Co. 451	McKissick, W. E. 452
Bambrick Thos. H. 461	McManus Jas. 454
Barrows H. H. & Son. 449	Michell H. F. Co. 446
Baur Floral Co. 449	Michigan Cut Flower Exchange. 455
Bayersdorfer H. & Co. 452	Millang Bros. 455
Bay State Nurseries. 436	Millang Frank. 455
Beaven E. A. 452	Mineralized Rubber Co. 463
Bernine H. G. 455	Maltz, A. 455
Boddington A. T. 447	Moninger J. C. 463
Boston Florist Letter Co. 451	Montrose Greenhouse. 435
Boston Plate and Window Glass Co. 462	Moore Frank L. 462
Bosch, Felix. 434	Moore, Hentz & Nash. 455
Bostrom-Lacey Mfg. Co. 453	Moore, J. L. 435
Bowe, M. A. 450	Morris Nursery Co. 436
Braslan Seed Growers Co. 447	Morse C. C. & Co. 447
Breck Joseph & Sons 447	Murdoch J. B. & Co. 452
Breitmeier's J. Sons. 450	Murray Samuel 450
Bremond Martial. 447	New England Nurseries 436
Bridgeman's Seed Warehouse. 447	Niessen Leo Co. 453
Burpee W. A. & Co. 449	Ordonez Bros. 449
Carrillo & Baldwin 449	Ouwkerk P. 430
Cassidy I. 403	Paietherpe P. R. Co. 462
Champion J. N. & Co. 451	Park Floral Co. 450
Chicago Carnation Co. 435	Parshelsky Bros. 462
Clarke's David, Sons. 450	Payne John A. 462
Cleary's Horticultural Co. 455	Pennock-Meehan Co. 452
Conard & Jones Co. 434	Perkins St. Nurseries 436
Conke G. H. 450	Peter's Nursery Co. 436
Cowee A. 434	Pierce F. O. Co. 463
Craig, Robt. Co. 434	Prierson, A. N. 434
Dingee & Conard Co. 436	Pierson F. R. Co. 444
Dvane Geo. B. & Son 473	Pierson U. Bar Co. 464
Donohoe W. H. 450	Pehlman Bros. Co. 444
Dorner F. Sons & Co. 435	Pulverized Manure Co. 462
Dreer H. A. 435	Raynor John L. 454
Dunlop John H. 451	Red Oak Nurseries. 434
Dysari R. J. 452	Reed & Keller. 455
Eagle Metal & Supply Co. 463	Reid Edw. 452
Edgar, W. W. Co. 453	Reinberg Peter. 452
Ewards Folding Box Co. 452	Rice Bros. 452
E. Hott Wm. & Sons. 446	Rickards Bros. 447
Ellwanger & Barry. 456	Robinson H. M. & Co. 455
Esler J. G. 462	Rock Wm. L. Flo. Co. 450
Erest W. H. 462	Roehrs Julius Co. 449
Eyres 450	Rolker August & Sons 434
Farquhar R. & J. & Co. 436	Rose Hill Nurseries. 434
Fenrich J. S. 454	Rusconi D. 449
Fiske, H. E. Seed Co. 447	Sander & Son. 449
Foley Mfg. Co. 463	Schulz Jacob. 450
Ford Bros. 454	Scott, John. 449
Froment H. E. 454	Sheridan W. F. 454
Galvin Thos. F. 451	Shurtleff J. B. & Son. 434
Gansey M. V. 451	Siggers & Siggers. 462
Grey T. J. Co. 447	Sim, Wm. 445
Gude Brs. Co. 450	Situations & Wants. 461
Guttman Alex. J. 454	Skidelsky S. S. 435
Haerens A. 462	Slinn B. S., Jr. 454
Hall Assn. 462	Smith H. J. 452
Haines, J. E. 435	Smyth Wm. J. 450
Hart, Geo. B. 451	Standard Plate Glass Co. 462
Hartmann Hjalmar & Co. 447	Stearns A. T. Lumber Co. 462
Hauswirth M. C. & J. E. 450	Stump & Walter Co. 447
Herbert David & Son. 435	Sunnywood Greenhouses. 462
Hews A. H. & Co. 402	Thorburn J. M. & Co. 447
Hicks Frank S. & Co. 455	Totty Chas. H. 435
Hilfinger Bros. 402	Traendly & Schenck. 454
Hill, The E. G. Co. 444	Turner W. F. & Co. 435
Hoffman 451	Turney D. J. 435
Horan E. C. 454	Valentine, J. A. 450
Houghton & Clark. 451	Veltbuys K. 474
Jacobs S. & Sons. 463	Vick's Jas. Sons. 447
Jager, Chas. J. Co. 462	Vincent R. Jr. & Sons. 434
Kasting W. F. 455	Wagner Park Conservatories. 451
Kepper J. A. 402	Ward R. M. & Co. 449
Kervan Co., The. 453	Waterer John & Sons. 436
Kessler, P. P. 454	Weber F. C. 450
King Cons. Co. 463	Weeber & Don. 447
Koral Mfg. Co. 451	Welch Bros. 452
Kramer Bros. Fdy Co. 464	Wilson. 430
Kuebler Wm H. 455	Winterston, E. F. Co. 452
Lager & Hurrell 449	Witthold Geo. Co. 451
Langjahr Alfred H. 454	Woodrow, Sam'l A. 455
Leonard I. & J. 434	Vokohama Nursery Co. 449
Leuthy A. & Co. 434	Young John. 434
Lewis A. F. Mfg. Co. 441	Young, Thos. Jr. 450
Lord & Burnham Co. 464	Young & Nugent. 450
Lutton W. H. 463	Zangen O. V. 447
	Zinn J. A. 451

IS YOUR NAME IN THE ABOVE LIST? IF NOT, WHY NOT?

GREENHOUSES BUILDING OR COMPLETED.

Cleveland, O.—F. R. Williams Co., 8 houses, each 25x300.
 Indianapolis, Ind.—A. Wiegand, show conservatory.
 Brampton, Ont.—Dale Estate, made of orchid houses.
 New Castle, Ind.—Weiland & Olinger, five houses, each 30x300.
 Grand Rapids, Mich.—Grand Rapids Greenhouse Co., ten houses, each 10x500.
 Toronto, Can.—McIntyre & Trimble, range of houses.
 Roslyn, Pa.—Edward Towill, rose house, 35x150.
 Brockville, Ont.—Brockville Asylum, one house.

A LOW-PRICED LEVEL.

Gardeners, park men and others whose work calls for the use of a leveling instrument should investigate the Bostrom Improved Level, advertised in this paper. Its simplicity and low price as compared with the complex instruments heretofore considered indispensable should popularize it at once. We have a letter from the department of horticulture and landscape gardening of the Michigan State Agricultural College stating that this instrument has been given a practical trial in their field work and has proved to be the best in its class. Send to the manufacturers for a descriptive circular.

HAIL LOSSES.

The florists of Southern Indiana were visited by a heavy hail storm on March 18 which, despite the immediate measures taken for relief means considerable loss at this season. The victims include D. H. Schilling, F. A. Conway & Co., E. Hukreide, H. Rieman, City Greenhouses, and numerous market gardeners of Indianapolis and G. R. Gause of Richmond.

WANTS, FOR SALE, ETC.
 Advertisements in this column one cent a word. Initials count as words. Cash with order. All correspondence addressed "care HORTICULTURE" should be sent to 11 Hamilton Place, Boston.

HELP WANTED

WANTED — SALESMAN
 To Handle Good Side Line On Commission
 One who calls on Florists, Seed Houses, Nurseries, Cemetery Superintendents, Monument Dealers, etc.
The Kramer Bros. Foundry Co.
 DAYTON, OHIO

HORTICULTURE needs a wide-awake representative in every town in the land. Good commission paid on advertising and subscriptions. If you are ambitious, write for terms.

HELP WANTED WANTED

A competent man for designing and packing room to take full charge. Must be a first-class workman on funeral work and be thoroughly experienced in the retail cutflower line. Also one experienced on pot plants and design work. Good situations for the right men. Apply with references.

S. J. REUTER & SON.. Inc.
 Westerly, R. I.

WANTED—A good all around man for greenhouse work and one who has a good knowledge of palms, azaleas, etc. State experience and wages desired. Address Palms, care of HORTICULTURE.

SITUATIONS WANTED

GOOD MEN
 When you need good men, skilled or unskilled, Write:
THOS. H. BAMBRICK
 34 South 7th Street Philadelphia
 Help of all kinds, including that for Florists, Nurserymen, Seedsmen and the Horticultural trade generally.

By competent all-round man as foreman of first-class place where full charge is given. A No. 1 grower of chrysanthemums, carnations, roses, pot plants and nursery stock for high-class retail trade. Long experience in handling men to best advantage. A hustler, American, no drinker. Permanent position, fair treatment and good wages expected. State wages. Address Horticulturist, Fairfield, Conn.

SITUATION WANTED in general greenhouse work; single, age 35, five years' experience, commercial. Address W. W., care HORTICULTURE.

FOR SALE

FOR SALE—Five acres of good land, three greenhouses of 6000 sq. feet glass, nearly new, 100 hotbed sash, 8 room dwelling, in good town, at a bargain. Address John A. Miller, Gardener, Creston, Ia.

FOR SALE—A large consignment of 16x 24 double thick American glass, A and B quality. For further information write Parshelsky Brothers, 59 Montrose Avenue, Brooklyn, N. Y.

FOR RENT.

FOR RENT—Six greenhouses, three acres fine soil, for term of years. Cheap. Address William Harris, Arlington, N. J.

MISCELLANEOUS WANTS

TO LEASE OR RUN UNDER SHARES.

The owner of a small nursery and well stocked greenhouse and flower shop now doing business in Northampton, will make a liberal business offer (based on lease or shares) with an enterprising nurseryman and florist of training and experience. Apply to the Home-Culture Clubs, Labor Exchange, Northampton, Mass.

WANTED to lease with privilege of buying, a few small greenhouses with about ten acres rich tillable land suitable for growing nursery stock, asters, etc., in good retail district; state rent, size of houses, city water, railway facilities, etc. Address Landscape, Fairfield, Conn.



JAGER SPRAYERS

are money savers because they enable you to do the work right, with little labor and without wasting solution. We make an outfit for every need, from large Power Sprayers to small Hand Sprayers—each the best of its kind. **Special Sprayer Book Free**, illustrating and describing our complete line. Investigation pays.
 Chas. J. Jager Co., 251-3 Franklin St., Boston, Mass.
 Branch: 31 Canal St., Providence, R. I.



The Best Bug Killer and Bloom Saver

For PROOF Write to
P. R. Palethorpe Co.
 OWENSBORO, KY.

PATENTS

Trademarks and Copyrights

Send your business direct to Washington. Saves time and insures better service. Personal attention guaranteed. Twenty-five years' active service. SPECIALTY: "Working on the Failure of Others."

SIGGERS & SIGGERS
 PATENT LAWYERS
 Box 9, National Union Building
 Washington, D. C.

BOSTON PLATE & WINDOW GLASS CO.
GREENHOUSE GLASS
 German and American
 261 to 287 A St., Boston 20-22 Canal St.



Cattle Manure In Bags

Shredded or Pulverized

Best and safest manure for florists and greenhouse use, absolutely pure, no waste, no danger. Write for circulars and prices.
 The Pulverized Manure Co.,
 31 Union Stock Yards, Chicago

SEE **BUYERS' DIRECTORY FOR BARCAINS**

SQUABS

Every man should have at least 10 to 20 pair of the celebrated Plymouth Rock Homer Pigeons or their own squab raising. It pays and is a pleasure besides. Write the undersigned for prices on mated birds.

THE BEST IN THE WORLD
 Jno. A. Kepner, Box 3, Harrisburg, Pa.

GREENHOUSE GLASS

Cheaper Now Than For Years

We are taking contracts for next Spring delivery.

WRITE FOR OUR PRICES

STANDARD PLATE GLASS COMPANY
 26-30 Sudbury St. 61-63 Portland St.
 BOSTON, MASS.

GLASS

Greenhouse and Hot Bed

SIZES OUR SPECIALTY IMMENSE STOCK

Plate and Window Glass
 Write us for Our Prices.

PARSHELSKY BROS.
 59 Montrose Ave., BROOKLYN, N. Y.



SUNNYWOODS HOSE

Used and recommended by



See page 394 of March 21st HORTICULTURE

OR ADDRESS
FRANK L. MOORE
 CHATHAM, NEW JERSEY

In ordering goods please add "I saw it in HORTICULTURE."

JOHN A. PAYNE GREENHOUSE

Designer & Builder
 260-274 Culver Ave.
 JERSEY CITY, N. J.



IRON FRAME SEMI-IRON FRAME TRUSS ROOF WOOD FRAME
Material Only or Erected
 Everything for the Greenhouse

CYPRESS SASH BARS

82 feet or longer
 HOT BED SASH
 PECKY CYPRESS BENCH LUMBER

GREENHOUSES

ERECTED AND EQUIPPED COMPLETE IF DESIRED

Write for Circular "D" and Prices

The A. T. STEARNS LUMBER CO.
 NEPONSET, BOSTON, MASS.

DREER'S

Florist Specialties.
 KEYSTONE CEDAR PLANT TUBS.

A	11 in.	65	7.15	55.00
B	12 1/2 "	75	8.25	65.00
C	14 "	85	9.35	75.00
D	15 1/2 "	100	11.00	90.00
E	17 "	125	13.75	110.00
F	18 1/2 "	150	16.50	130.00

Three largest sizes have handles
Special PAIL TUBS.
 8 inches 3.50 28.00
 11 " 3.50 28.00
 Painted Green
HENRY A. DREER,
 714 Chestnut Street,
 PHILADELPHIA, PA.

STANDARD FLOWER POTS

Packed in small crates, easy to handle.

1500 2 in. pots in crate	\$4.88	120 7 in. pots in crate	\$4.20
1500 2 1/4 " " " "	5.25	60 8 " " " "	3.00
1500 3 " " " "	6.00	HAND MADE	
1000 3 1/2 " " " "	5.80	48 9 in. pots in crate	\$3.60
500 4 " " " "	4.50	48 10 " " " "	4.80
320 5 " " " "	4.51	24 11 " " " "	3.60
144 6 " " " "	3.16	24 12 " " " "	4.80
		12 14 " " " "	4.80
		6 16 " " " "	4.50

Seed pans, same price as pots. Send for price list of Cylinders for Cut Flowers, Hanging Baskets, Lawn Vases, etc. Ten per cent. off for cash with order. Address **Hilfinger Bros., Pottery, Fort Edward, N. Y.** August Rolker & Sons, Agts., 31 Barclay St., N. Y. City.

Standard Flower POTS

If your greenhouses are within 500 miles of the Capitol, write us, we can save you money

W. H. ERNEST
 28th and M Street WASHINGTON D. C.

The FLORISTS' HALL ASSOCIATION OF AMERICA, insurer of 28,000,000 sq. ft. of glass. For particulars address **John C. Esler, Sec'y, Saddle River, N. J.**

WILLIAM H. LUTTON

HORTICULTURAL ARCHITECT AND BUILDER

WEST SIDE AVENUE STATION (C. R. R. OF N. J.)
JERSEY CITY, N. J.

Have not been established 50 years, but long enough to convince the wide-awake Florist and Gardener that it is to his interest to place his work in thoroughly practical hands.

(150,000 sq. ft. glass erected in 1907 will substantiate this claim.)

And why not? My material is the best that can be secured. My iron frame construction has every modern feature that years of practical experience can embody.

AND THEN THERE IS THE COST TO BE CONSIDERED.

Why not let us take up this important question now?

IRON PIPE

SECOND HAND

WROUGHT IRON PIPE, for Steam, Water, Gas or Oil, Fences or Posts. All Sizes. Price Low.

GEO. B. DOANE & SON
18 Midway Street, BOSTON
Telephone, Main 4419

ISAAC CASSIDY

Summer Ave. & Erie R.R., Newark, N. J.

Write for Prices

GREENHOUSE MATERIAL
CONSTRUCTION FITTINGS

Bench Fittings

Material Furnished and Erected

R. TOMAWANDA, N. Y.

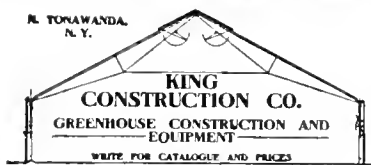

GREENHOUSE CONSTRUCTION LUMBER

John C. Moninger Co.
117 E. Blackhawk St., CHICAGO

Holds Glass Firmly
See the Point FULL SIZE N. 2

PEERLESS

Glazing Points are the best. No rights or lefts. Box of 1,000 points 76 cts. postpaid.

HENRY A. DEER,
714 Chestnut St., Phila., Pa.

THE FOLEY MFG. CO.

CHICAGO

Completely equipped with up-to-date machinery for the making of material for

GREENHOUSE CONSTRUCTION

From a Full Supply of Thoroughly Seasoned Lumber

Send your sketches to our draughtsmen for completion and suggestion. Permit us to figure your proposed work, large or small.

We guarantee our prices will save you money

FOLEY VENTILATING APPARATUS IS THE BEST

Is Simple in Erecting. Is Easiest of Operation. It Will Last a Lifetime. Its Price is the Lowest. Will Ventilate Any Size House. Prices and Circulars on Application.

Our 1908 Catalogue Greenhouse Material Sent Postpaid on Request.

**THE FOLEY MFG. CO., WESTERN AVENUE
25th and 26th STS., CHICAGO**

MASTICA

FOR Greenhouse Glazing

USE IT NOW.
F. O. PIERCE CO.
12 W Broadway and
227 Greenwich St.
NEW YORK

SECOND HAND PIPE & BOILER TUBES

Of all sizes, in good condition, suitable for steam purpose, coupled and threaded, for sale at low rates.

5000 feet 1 inch pipe, 3c. per ft.; 5000 feet 1 1/2 inch pipe, 4c. per ft.; 3000 feet 2 inch pipe, 5c. per ft.; 2000 feet 2 1/2 inch pipe, 6 1/2c. per ft.

EAGLE METAL & SUPPLY CO.,
Johnson and Union Aves., BROOKLYN, N. Y.

ANCHOR GREENHOUSE HOSE

WEARS WELL.

PLANT BED CLOTH

Protects from Cold and Dampness.

MINERALIZED RUBBER CO.
18 Cliff Street New York

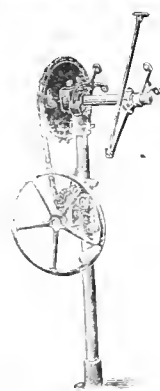

The Advance Ventilating Apparatus

pleases all of our customers, because it is neat, strong, works easy, and is sold at one price to all at a reasonable profit. Get our estimates, and give us a trial.

The Advance Co.
RICHMOND, IND.

S. JACOBS & SONS
Manufacturers of GULF CVPRESS

GREENHOUSE MATERIAL

HOT-BED-SASH & FRAMES

Jobbers in **Boilers-Pipe-Fittings** and

GLASS on which we can quote attractive prices. Disc on large quantities.

We furnish everything for Greenhouse Building
**1365-1379 Flushing Avenue
BROOKLYN, - NEW YORK**



Mr. FLORIST
Why Don't
You Sell

VASES

Every vase sold
means more
business for you

This Business
belongs to you

Will you let us
show you how
to get it?

Write for
Catalogue "B"
on VASES

**The Kramer
Bros. Fdy.
Company**
DAYTON, O.

Largest Mfg. of
Vases in the U.S.

Do You Know About That Economical Cross FIRE CHANNEL In The "BURNHAM"?

Then Send for this catalog.

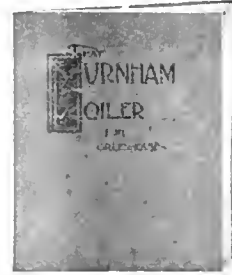

WE MAKE EVERY PART OF A GREENHOUSE
OF THE CLASS. WE SELL ANY PART.

LORD & BURNHAM CO.

MAIN SALES OFFICE:
1133 BROADWAY, NEW YORK

BOSTON: 570 Tremont Building
PHILADELPHIA: 1215 Filbert St.

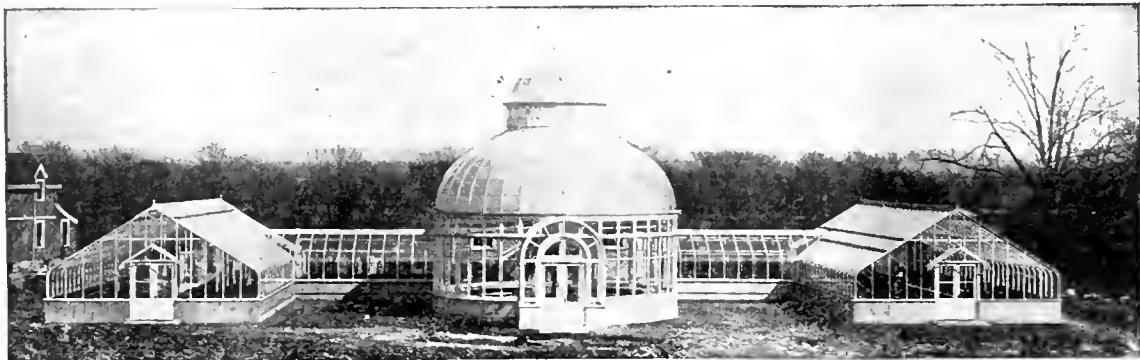

WHAT FIRST IMPRESSES YOU

when seeing a range of U-Bar houses is their absolute simplicity and wonderful lightness of construction. It is this simplicity, this lightness that makes them always so pleasing in effect and such wonderful growing houses. The catalog shows various views of this range, both exterior and interior. It also shows in a plain enough way exactly what makes the U-Bar houses the superior houses they are. Send for the catalog.

U-BAR GREENHOUSES

PIERSON
DESIGNERS AND BUILDERS



U-BAR CO.
11 MADISON AVE., NEW YORK

HORTICULTURE

Vol. VII. APRIL 11, 1908 No. 15



✠ Easter 1908 ✠

ROSES FOR DECORATION DAY

Remember You May Deduct 5 Per Cent if Cash Accompanies Order

Hardy Perpetual Roses

We offer exceptionally strong two-year-old dormant, low-budded stock (on Manetti) in the following varieties, true to name:

Alfred Colomb Carmine.
Anne de Diesbach Bright carmine.
Ball of Snow Pure white.
Baron de Bonstetten Dark crimson shaded
Baroness Rothschild Satiny pink; extra.
Captain Christy Delicate flesh color.
Duke of Edinburgh Bright vermilion.
Frau Karl Druschki The finest white in existence.

Fisher Holmes Dark rich scarlet.
General Jacqueminot Rich velvety crimson.
John Hopper Beautiful rose-pink.
General Washington Beautiful red, shaded
 carmine.
La France The finest light pink.
Margaret Dickson White, pale flesh center.

Magna Charta Clear rosy pink.
Mme Gabriel Luizet Light, satiny pink.
Mme. Plantier White.
Mr. John Laing Soft pink; most desirable
 variety.
Paul Neyron Beautiful dark pink.
Prin e Camille de Rohan Velvety crimson.
Ulrich Brunner Cherry-red.

The Grand Pink Hybrid Perpetual Rose **Mrs. Sharman Crawford**. One of the finest Roses grown Deep rosy pink, the outer petals shaded with pale flesh-color, white at the base of petals, and distinct from all other Hybrid Perpetual Roses. Bundle of 5 for 75c; 100 for \$15.00.

We also carry about 25 other varieties. Write for list and price. Prices on Hardy Hybrid Perpetual Roses, \$1.50 for 10; \$12.00 per 100; \$110.00 per 1000.

ENGLISH MOSS ROSES

Assorted, White, Pink, Red. Large dormant plants, from open ground. 85c for 5; \$12.00 per 100.

STANDARD, or TREE ROSES

(Grafted on *Rosa Canina* or *Rugosa* Stock) Large, well grown, selected plants in the best and most serviceable varieties. 35c each; \$3.25 for 10; \$25.00 per 100.

Baby Ramblers

THE TREE BABY RAMBLER—Grown as a Standard

35c each; \$3.50 per doz.; \$25.00 per 100.

Mme. Norbert Levavasseur (Baby Rambler). Strong, field-grown plants: \$1.25 for 10; \$12.00 per 100.

Catherine Seimeth. A very important novelty. A white Baby Rambler rose, larger and better flowers than the type. White with yellowish center. It has the true rose perfume in a high degree. 45c each; \$4.50 per doz.; \$35.00 per 100; extra strong, 60c each; \$6.00 per doz.; \$45.00 per 100.

Anny Muller. The pink Baby Rambler, and bound to find favor where the Baby Ramblers are popular. 45c each; \$4.50 per doz.; \$35.00 per 100.

Mrs. Wm. H. Cutbush. A grand acquisition to the Baby Rambler class.

Color intense crimson, and exceptionally free-flowering. 25c each; \$1.00 for 5; \$18.00 per 100.

Baby Dorothy. The same in habit as Baby Rambler, but the color of the flowers is similar to Dorothy Perkins. This variety has created quite a sensation when exhibited at the English National Rose Society's and other shows. "Baby Dorothy," when planted out, flowers perpetually from spring until autumn. It makes an excellent pot plant for forcing. Price for strong, field-grown plants, 50c each; \$2.00 for bundle of 5; \$35.00 per 100.

Hybrid Tea, or Everblooming Roses

Hybrid Tea, or Everblooming Roses are becoming more popular every year. As hardy as the perpetuals, with slight protection in winter, they give a wealth of bloom all through the summer months and late in the fall till frost checks them.

The Grand New Rose Lyon Originated by the raiser of Etoile de France. Perpetual flowering. Vigorous grower. The blooms are very large with broad petals, full and globular in form; shrimp pink at the ends of the petals, center coral red or salmon pink shaded with chrome yellow. Very fragrant. \$1.25 each; \$6.00 for bundle of 5; \$12.00 for 10.

The Killarney Rose This is a grand rose for either indoor or outdoor cultivation; is a strong grower, and the blooms, which are of a beautiful pink, are borne in great profusion. Strong, two year-old field-grown stock, 25c each; \$1.00 for bundle of 5; \$18.00 per 100.

Flaman Cochet Roses. The best of all Roses for summer flowering and cutting.

Pink—Color a clear, rich pink changing to silvery rose, very double and fragrant.

White—A sport from the above, with all its characteristics, color a beautiful snow-white, at times tinted with the faintest suggestion of blush, the same as is often found in the Bride. 25c each; 75c for bundle of 5; \$12.00 per 100.

Rose, Etoile de France. Flower large, possessing petals of very good substance; magnificent cupped form. Superb crimson red velvet, the center of the bloom vivid cerise-red. The flowers are very fragrant and last very

long. The Queen of the Everblooming Red Roses. The most free-blooming and vigorous Red Rose ever introduced. Strong, 2-year-old plants, field grown, 25c each; \$1.00 for bundle of 5; \$18.00 per 100.

Gru's an Teplitz. No Rose in commerce can compare with Gru's an Teplitz as a budler. It is a perfect sheet of richest crimson-scarlet all summer. A strong, vigorous grower. Hardy. 20c each; \$1.50 for 10; \$12.00 for 100.

New Hybrid Tea Rose, Queen of Spain. This grand Rose is without doubt the Rose of the season, a seedling from Antoine Riviere and a H. P., with the scent of *Sour de la Malmaison*, the color is pale flesh, darker in the center. Flowers are erect on stout stems, very full, and of excellent form; petals broad and leathery, a good opener and strong grower. 75c each; \$2.25 for bundle of 5.

Countess of Gosford. (New.) A very beautiful variety of the Hybrid Tea class, somewhat resembling Killarney. Color delicate pink; fine flower and bud; a splendid acquisition. 50c each; \$2.50 for bundle of 5.

POPULAR HYBRID TEA ROSES

American Beauty, Kaiserin Augusta Victoria, Clothilde Souper, Caroline Testout, Hermosa. 20c each; 75c for bundle of 5; \$12.00 per 100.

Rambler Roses

Dorothy Perkins. Resembles the Crimson Rambler, except in color, which is a lovely shell-pink. 15c each; 65c for 5; \$12.00 per 100.

Crimson Rambler Rose. American grown. We can supply extra-strong.

WELL-KNOWN CLIMBERS.

Mme. Plantier, white. **Baltimore Belle**, pale blush color. **Prairie Queen**, red, changing to pink. **Seven Sisters**, clear pink. 15c each; 75c for 5; \$12.00 per 100.

New Climbing Rose, CLIMBING FRAU KARL DRUSCHKI. This is a climbing sport from the well known snow-white variety, Frau Karl Druschki, and should become very popular. Good, strong plants are offered as follows: 50c each; \$2.50 for 5.

Our Wholesale Catalogue of Quality seeds and bulbs now ready and it contains forty pages of seeds and bulbs and roses you need, fully described. Write for it to-day—a postcard will fetch it.

ARTHUR T. BODDINGTON, Seedsman, 342 West 14th St. NEW YORK CITY

CANNA BULBS

Fine plump, Northern Grown, and in fine condition. Not to be compared with Southern grown stock, that are never thoroughly ripened and therefore are very slow to start growing.

	Doz.	100	1000		Doz.	100	1000
Allemania	\$0.35	\$2.50	\$22.50	Gladiator	\$0.40	\$3.00	\$27.00
Black Prince	.40	3.00	27.00	King Edward	.50	3.50	32.00
Black Warrior	.35	2.50	22.50	Louisiana	.55	4.00	35.00
Burbank	.30	2.25	20.00	Mad. Crozy	.40	3.00	27.00
Black Musafolia	.40	3.00	27.00	Mlle. Berat	.30	2.25	20.00
Charles Henderson	.35	2.50	22.50	Musafolia	.30	2.25	20.00
Director Roe z	.35	2.50	22.50	Paul Marquant	.30	2.25	20.00
Flamingo	.30	2.25	20.00	Pres. McKinley	.35	2.50	22.50
Florence Vaughan	.35	2.50	22.50	Queen Charlotte	.35	2.50	22.50
Golden Star	.30	2.25	20.00	Robusta	.30	2.00	18.00
				Red Cross	.30	2.25	20.00

STUMPP & WALTER CO., 50 Barclay St., NEW YORK

GERANIUMS A splendid stock of fine plants in 2 inch pots, good standard sorts and new varieties at \$2.00 per 100 and up to \$1.00 each. We will send 1000 in 20 good varieties, our selection, for \$18.50. Our special descriptive **Geranium Catalogue**, describing over 250 varieties of Geraniums and Pelargoniums mailed free to the trade.

PELARGONIUMS In good variety, strong plants from 3 inch pots at \$1.50 per dozen, \$6.00 per 100.

HARDY CHRYSANTHEMUMS Our collection of Hardy Chrysanthemums will compare favorably with any in the country and we have an immense stock ready for shipment. Small flowered or Button Varieties, \$2.00 per 100. Large Flowered or Aster Varieties, \$3.00 per 100. Description will be found in our Wholesale List.

DAHLIA ROOTS We still have about 75 varieties we can offer in Cactus, Decorative, Show and Pompon true to name at \$3.00 per 100 and up for Whole Field-grown clumps. One thousand, 50 each of 20 varieties our selection, for \$40.00, all good kinds; a splendid collection for planting or just the thing for Store Trade.

	Per 100		Per 100
Alyssum, Giant Double	\$2.00	Hardy Phlox	2.00
Ageratum, Stella Gurney	2.00	Hollyhocks, Strong 3 in. pot plants, dbl. white, pink, red and yellow	3.00
Begonia, Vernon, White and Rose	2.00	Ivy Leaved Geraniums, 6 good kinds, \$28.00 per 1000	3.00
" Gracilis, White and Rose	2.00	Lobelia, Crystal Palace Gem	2.00
Cuphaea, Cigar Plant	2.00	Lantanas, 5 varieties	2.00
Coleus, Verschaffeltii, Golden Bedder and other kinds	2.00	Lavender, 2 1/2 in. pots strong	3.00
Caladium, Esculeotum, 1st size \$2.00 per 100, 2nd size	1.00	Panicum, Variegated, Handsome basket plants	2.00
Fuchsias, Black Prince and Minnesota	2.00	Swainsona, Alba	2.00
Lieutenant Muritz, White and Rose Phenomenal	2.80	Salvia, Bonfire and Splendens	2.00
Hardy English Ivy, Extra Strong. \$15.00 per 1000	2.00	Tradescantia, Dark Variegated	2.00
		Verbena, Red, White, Purple and Pink	2.00

R. VINCENT JR. & SONS COMPANY, White Marsh, Md.

YOU WANT THEM NOW

Before the cream of the varieties is all sold. The finest stock of standard

HARDY PERENNIALS

in the country. Write and we'll quote tempting prices.

Red Oak Nurseries, Fiskeville, R. I.

AZALEAS for fall delivery, the best that are grown, also **PALMS** for spring or fall delivery, furnished by **AUGUST HAERENS, Somergem, Belgium**; orders booked now....

ADDRESS THE AMERICAN REPRESENTATIVES
AUGUST ROLKER & SONS, 31 Barclay Street, or P. O. Box 752, New York

CANNAS

Send for our List and Prices

The CONARD & JONES CO. WEST GROVE, PA.

LIVE CANNAS

Started from Sand at \$2.00 per 100

Austria, Robusta, Pennsylvania, Chas. Henderson, Italia, Pres. Carnot, Mlle. Berat, A. Bouvier, Duke of Marlborough.

J. B. SHURTLEFF & SON, Cushman Ave., Revere, Mass.

JOHN E. HAINES Bethlehem, Pa.

is the place to order rooted-cuttings of the following varieties for 1908.

John E. Haines, red imperial variegated	} Per 100 Per 1000	
Pink Imperial, Pink Enchantress, Light Pink		
\$6.00		\$50.00
Place your orders early for Jan. delivery.		

Carnation Cuttings

Both standard varieties and novelties. Stock guaranteed to be first-class. Address,

S. S. SKIDELSKY

1741 North 18th Street, Philadelphia

COLEUS

Verschaffeltii, Golden Queen, Fire Brand, Lord Palmerston, Queen Victoria, Beckwith's Gem. Prices of Rooted Cuttings by express, 60c. per 100; \$5 per 1000. Less than 250 of a variety will be charged at the 100 rate.

Golden Bedder, Hero, Tessey, Pearl of Orange. 75c. per 100, \$7.50 per 1000. Less than 250 of a variety will be charged at the 100 rate.

Fancy Varieties. A very fine assortment of twelve kinds not listed above. 75c. per 100; \$6 per 1000. 25c. in assortment, our selection, at the 1000 rate.

MISCELLANEOUS PLANTS

AGERATUM, Stella Gurney, Princess Pauline. SALVIA Splendens, Bonfire. HELIOTROPE. Rooted cuttings, 75c. per 100, \$7.50 per 1000.

CARNATIONS

	100	1000
Winsor	\$6.00	\$50.00
White Perfection	2.50	20.00
Rose Pink Enchantress	3.50	30.00
Enchantress	2.50	20.00
Queen Louise	2.50	20.00

From 2 1/4 inch pots, add \$1.00 per 100.

ASPARAGUS PLUYDOSUS NANUS SEEDLINGS From flats, \$1.00 per 1000.

CHRYSANTHEMUMS

Standard varieties, ready for shipment. Rooted cuttings, \$2 per 100; \$15 per 1000. Send for list.

A. N. PIERSON, CROMWELL, CONN.

GLADIOLI

I can satisfactorily supply your wants for Gladioli for forcing or outdoor planting. Mixtures, color sections or named varieties of exceptional beauty.

Write for Prices

ARTHUR COWEE

Gladiolus Specialist

Meadowvale Farm, BERLIN, N. Y.

GLADIOLUS BULBS

100,000, from 1 1/4 inches up @ \$4.00 per 1000
100,000, 3/4 to 1 1/4 inches @ \$2.00 per 1000

Cash with order. Description given on request. Nice block of California Privet, \$10.00 per 1000 and up, as to quality. Write for particulars.

Nice lot of American Chestnut Trees at a bargain. Thirty-five large Sugar trees, most of them sample trees.

L. & J. L. LEONARD, IONA, N. J.

CARNATIONS

WINONA - The True Pink
\$12.00 per 100, \$100.00 per 1000

	Per 100	Per 1000
Red Chief	\$5.00	\$40.00
Aristocrat	6.00	50.00
Winsor	6.00	50.00
Beacon	6.00	50.00
White Perfection	3.00	25.00
Rose Pink Enchantress	3.00	25.00
Enchantress	3.00	25.00
Lady Bountiful	3.00	25.00

F. DORNER & SONS CO., LAFAYETTE, IND.

ROOTED

CARNATION CUTTINGS

Only the Best Varieties

CHICAGO CARNATION CO., JOLIET ILL.

New Violet BOSTON

In introducing this new variety to the trade I wish to state that I have been growing it in quantity for the past two years and do not hesitate to state that it is entirely distinct, a strong grower, a free bloomer, and the finest single violet in cultivation. Ready for distribution in April and May. Orders booked now. \$2 per 100; \$12 per 1000; \$100 per 10000. 500 at 1000 rate.

WILLIAM SIM,

CLIFTONDALE, MASS.

HARDY ROSES FOR THE GARDEN

Strong Field-grown Plants

The roses here offered are extra strong two-year-old field-grown blooming plants, which, if planted early, will give a large number of flowers the first year. They can be planted as early in the spring as the frost is out of the ground, and from that time until about the first week in May. We offer a grand collection of the best and choicest varieties, as follows:

HYBRID PERPETUAL OR JUNE ROSES

Frau Karl Druschki, Marchioness of Londonderry, Capt. Hayward, Mrs. R. G. Sharman-Crawford, Ulrich Brunner, Margaret Dickson, Baron de Bonstetten, Paul Neyron, Gen. Jacqueminot Magna Charta, Mrs. John Laing, Mme. Gabrielle Luizet, Marshall P. Wilder, Gloire de Paris, Baroness de Rothschild, Prince Camille de Rohan, Fisher Holmes, Alfred Colomb, Soleil d'Or, Persian Yellow, Moss Roses, Rugosa alba and rubra, etc.

MONTHLY AND HYBRID TEA ROSES

Etoile de France, Killarney, Mme. Abel Chatenay, Countess of Gosford, Koenigen Carola, Perle von Godesberg, Gruss an Teplitz, Maman Cochet, White Maman Cochet, Belle Siebrecht, Hermosa, Mme. Caroline Testout, Souv. de Pres. Carnot, Kaiserin Augusta Victoria, American Beauty, La France, Clothilde Soupert, Prince de Bulgarie, Mme. Norbert Levavasseur (Baby Rambler), Anny Muller (Pink Baby Rambler), Catherine Ziemet (White Baby Rambler), etc.

In Climbing Roses we have a nice stock of Crimson Rambler, Lady Gay, Dorothy Perkins, Dawson, Gardenia, Tausendschon, etc.

LET US KNOW THE QUANTITY YOU WANT AND VARIETIES, AND WE WILL BE GLAD TO QUOTE LOWEST PRICES ON SAME BY RETURN MAIL.

F. R. PIERSON CO., Tarrytown-on-Hudson, New York

ROSES

100 of the best Hardy sorts.

HYBRID PERPETUALS

Finest English Grown Plants

Dozen, \$3.50; 100 \$25.00

EVERBLOOMING HYBRID TEAS

Bloom from Midsummer until frost.

Dozen \$5.00; 100, \$35.00

Hardy Climbing Roses

All the leading sorts.

Catalogue Free on Application.

R. & J. FARQUHAR & CO.

6 and 7 So. Market Street,
Boston, Mass.

FORESTRY PLANTING

10,000 Red Oak, 4 to 6 in. \$5.00. Ornamental Planting, Swiss Stone Pine, 3 yrs. 1 to 4 in. \$3 per 100, \$25 per 1000. Foxtail Pine, 3 yrs. 1 to 4 in. \$4 per 100. Bald four Pine, trans. 4 and 5 in. \$8 per 100. Mugho Pine, trans., 4 to 6 in. \$8 per 100. Compact Mugho Pine, dwarf, trans. 3 to 4 in. good stock 100. Hemlock, 6 to 8 in. trans. \$4 per 100. Larger sizes of all of above. Am. Yew, 1 to 1 1/2 in. trans. \$10 per 100. Specimen of Caroline Hemlock, K.K. Mr. Spruce, K.K. Mt. Silver Fir, 5 to 6 in. \$4 to \$4.50.
JACKSON'S NURSERIES, Portland, Me.

TAUSENDSCHON

or in English **Thousand Beauties**, is the sensational new Climbing Rose of the year. Every florist should have it. It is not excelled for forcing purposes and for general planting by any Climbing Rose now known, **not even baring Crimson Rambler**. This is the coming forcing Rose. Get your stock early. Illustrated in ten colors and gold in our Catalogue for 1908, the **Leading Rose Catalogue of America**. Every Rose worth having is described in it. Copy free for the asking.

Strong plants of Tausendschon from 3-inch pots,
10 for \$1.50; \$12.00 per 100; \$100.00 per 1000.

THE DINGEE & CONARD CO., WEST GROVE, PA.

HARDY NORTHERN GROWN NURSERY STOCK

At Reasonable Prices

FRUIT AND ORNAMENTAL TREES, SHRUBS, VINES, ROSES AND HERBACEOUS PERENNIALS IN GREAT VARIETY

Catalogue and Price List for the asking

BAY STATE NURSERIES, NORTH ABINGTON, MASS.

NEW RAMBLER ROSE "NEWPORT FAIRY" NEW

To be disseminated Spring, 1908. Ask for Illustrated pamphlet and prices

JULIUS ROEHRS CO., Rutherford, N.J.

The Roses that Win

MRS. POTTER PALMER, CARDINAL American Beauty and O'her Standard Varieties. Rooted from Our Famous Stock. Send for Prices.

POEHLMANN BROS. CO.
Morton Grove, Ill.

RHEA REID

READY NOW, Own Root, \$30 per 100, Grafted, \$35 per 100.

AMERICAN BEAUTY

Fine Young Stock, \$6 per 100, \$50 per 1000.

THE E. G. HILL CO., Richmond, Ind.

WATERER'S RHODODENDRONS

CONIFERS, LAURELS, SPECIMEN ORNAMENTALS

FAMED
ALL
OVER
THE
WORLD



SPECIAL
FOR
AMER-
ICAN
TRADE

ORDER NOW FOR NEXT SEASON.

SIZES AND PRICES ON APPLICATION.

JOHN WATERER & SONS

AMERICAN NURSERIES, - - BAGSHOT, ENGLAND

ROSES

- PERSIAN YELLOW, At \$12.00 per 100
- SOLEIL D'OR, At \$12.00 "
- CRIMSON RAMBLER, 3 to 4 ft. X line \$10.00 "
- WICHURIANA HYBRIDS, 2 year \$6.00 "
- CLEMATIS PANICULATA, 2 year \$8.00 "
- VIBURNUM Plicatum, 3 to 4 ft. \$15.00 "
- 4 to 5 ft. \$17.00 "
- 100,000 HARDY PERENNIALS, See Wholesale List.

The Elizabeth Nursery Co.,
ELIZABETH, N. J.

Established 40 Years

Rose Hill Nurseries

New and Rare Plants

NEW ROCHELLE, N. Y.

New York Office, Siebrecht Building, 425 Fifth Avenue

ROBERT CRAIG CO.

ROSES, PALMS,

and Novelties in Decorative Plants

MARKET and 49th STREETS., PHILADELPHIA, PA.

SPECIMEN EVERGREENS

Box Plants, Azaleas, Rhododendrons, Roses, Herbaceous Perennials
In fact everything in hardy stock for Garden, Lawn and Landscape Planting.
General Catalogue and Trade Lists on application.

The NEW ENGLAND NURSERIES, Inc., Bedford, Mass.

LIVE FENCES

We believe we are the largest growers of Hedge plants in America—Privet our specialty—can supply any quantity both

Amoor River and California, strong plants, at \$25.00 per M. Other varieties. Prices on application.

PETER'S NURSERY COMPANY, - Knoxville, Tenn.

The MORRIS NURSERY CO.
West Chester, PA.
NURSERIES ESTABLISHED 1849

SPECIALTIES for SPRING 1908

- Norway Maple, 2 1/2 in dia. and 2 1/2 in. dia.
- Carolina Poplars, 10-12 ft., 1 1/2-2 in.
- Cal. Privet Hedge Plants, 2 yrs. old 2-3 ft. and 3 and 4 yrs. old 3-5 ft. Dwarf Box, 3-6 in.
- Rhododendron Hybrids, 18-24 in. and 2-3 ft. choice hardy varieties
- Rhododendron Maximum, 2-8 ft., fine plants in car lots.
- Kalmia Latifolia, 1-4 ft., fine plants in car lots.
- Blue Spruce, Koster's, 3-5 ft.
- Hybrid Roses, choice varieties.

Catalogue mailed upon request. Address all communications to

The MORRIS NURSERY CO
Sales office, 1 MADISON AVE., NEW YORK

GRAFTED STOCK

BRIDE, BRIDESMAID and RICHMOND

Write For Prices

MONTROSE GREENHOUSES
MONTROSE, MASS.

Hardy Rhododendrons Azaleas Conifers, Clematis, H. P. Roses, Shrubs and Herbaceous Plants from our

HOLLAND NURSERIES

Prices Moderate

P. OUWERKERK, 246 Jane St., Weehawken Heights P. O. No. 1, Hoboken, N. J.

AMERICAN NURSERY CO., COMBIN-
ING

FRED'K W. KELSEY, New York City
F. & F. NURSERIES, Springfield, N. J.
BLOODGOOD NURSERIES, Flushing, L. I.
N. J. & L. I. NURSERIES

We can supply you every need. Write for prices

Sales Department
150 BROADWAY, - NEW YORK

FLOWERING PLANTS

My plants were never finer; order quick as stock is already low on some things

- ACACIA PARADOXA, nice specimens, \$5.00 to \$8.00 each.
- AZALEAS, \$6.00, \$9.00, \$12.00, \$15.00, \$18.00, \$24.00, \$30.00 and \$36.00 per dozen; larger plants, \$5.00 to \$15.00 each.
- Pyramids, \$4.00, \$5.00, \$6.00 and \$8.00 each.
- BORONIA ELATIOR, 4½ in. pots, \$4.00 per dozen; 5½ in. pots, \$12.00 per dozen; 6 in. pots, \$18.00 per dozen; 6½ in. pots, \$24.00 per dozen.
- ERICA Cavendishiana, 5½ and 6 in. pots, \$18.00 per dozen.
- GENISTA RACEMOSUS, 5½ in. pots, \$6.00 per dozen, 6 and 6½ in. pots, \$12.00 per dozen. Larger, \$1.50 to \$2.50 each.
- HYACINTHS, single, \$2.00 per dozen; in pans, \$6.00, \$9.00, \$12.00, \$18.00 and \$24.00 per dozen.
- HYDRANGEAS, \$12.00, \$18.00 and \$24.00 per dozen, blue and pink.
- LILIES, \$12.00 per 100, flowers or buds.
- LILY OF THE VALLEY, in pans, 50c., 75c. and \$1.00 each.
- ORANGES, fruited, \$18.00, \$24.00 and \$36.00 per dozen; large, \$5.00 and \$6.00 each. In bloom, \$2.00, \$3.00 and \$4.00 each.
- RHODODENDRONS, \$2.00 to \$5.00 each.
- ROSES, Baby Ramblers, 5½ and 6 in. pots, \$4.00, \$6.00, \$9.00 and \$12.00 per dozen.
- Crimson Ramblers, crowns, \$2.50 to \$10.00 each.
- Fan-shaped, \$2.00 to \$4.00 each.
- Baskets, \$3.00 to \$6.00 each.
- Umbrella shaped, \$8.00 each.
- SPIREA, \$6.00, \$9.00 and \$12.00 per dozen.

Price list may be had on application for PALMS, DRACAENAS, PANDANUS, FERNS, ARAUCARIAS, ASPARAGUS, ASPIDISTRAS, COCOS, CIBOTIUMS, BOXWOOD, BAY TREES, CYCAS, FICUS ELASTICA, LIVISTONAS, PHOENIX, RHAPIS, etc.

ANTON SCHULTHEIS
COLLEGE POINT, N. Y.

GOING FAST

If you want first-class Easter Plants

Order Immediately

WE SHALL BE

Sold Out On Many Things Soon

AZALEAS, LILIES, GENISTAS
ROSES, HYDRANGEAS
ARAUCARIAS, PALMS
PRIMROSES, ETC.

Are of the highest quality and prices are very reasonable. Good Packing and Prompt Delivery by Wagon in Boston or to Express.

A. LEUTHY
Plant Importer and Grower
ROSLINDALE, - MASS.

SURPLUS OF Japanese Lilies

LILIUM AURATUM,

8-9 in., a case of 130,

\$5.00, f. o. b. New York.

LILIUM RUBRUM,

8-9 in., a case of 200,

\$9.00, f. o. b. New York.

LILIUM RUBRUM,

10-11 in., a case of 140,

\$10.00, f. o. b. New York.

For Immediate Shipment.

YOKOHAMA NURSERY CO.
31 Barclay St., New York.

Flora's Harbingers of Spring

It is no surprise that spring has been celebrated in glowing terms by poets of all ages. Winter has its charms but it never can be compared with spring. Oh! what new life and vigor is given us when the first breath of balmy spring reaches us after a long, dreary winter. Even Solomon with all his riches, splendor and wisdom rejoiced when winter was gone and had this to say: "Lo! the winter is past, the rain is over and gone; the flowers appear on the earth; the time of the singing of birds is come, and the voice of the turtle is heard in our land."

THE BEAUTIES OF THE SPRING BULBOUS FLOWERS

Dead indeed to this world is the man who does not contemplate with admiration the beautiful jewels that come up out of the cold ground. How have they manufactured these beautiful shining colors from the damp, frozen earth? This and many others are the secrets and puzzles that trouble us each succeeding spring. Our hearts ache when we see these little messengers battered and beaten by frost and snow, but we admire and love them for their courage.

Oh! you little wonders. You are more precious to me than diamonds and gladly would I go on bended knee at your first appearance and adore you. We are glad we have learned and know that you have not come through frost and snow to please man alone. The busy bee, your sweet companion, is out and about and he also admires fine forms and bright colors and is soon doing a work which is the principal object of all living things.

EVERYBODY SHOULD PLANT THEM

Leaving the sentimental and coming to the practical, we are indeed sorry that for every dozen planted of the early spring flowering bulbous plants such as snowdrops, crocuses, glory of the snow, squills and the like, there are not millions throughout this great land. They are of the very easiest culture, needing no protection of any kind and will grow and flourish in almost any kind of soil or situation. Thousands and thousands of dollars are spent erecting expensive greenhouses and paying coal bills and I venture to say that we have no plants in our greenhouses that will compare with masses of scillas, glory of the snow and crocuses that are grown so cheaply out of doors. We get larger blossoms like amaryllises with gaudy colors in our greenhouses, but to the true lover of flowers the little gems of early spring are by far sweeter and more pleasing. In fact, the comparison is like comparing diamonds to blocks of granite.

EASE OF CULTURE

Some will be surprised to know how many beautiful plants are in bloom as early as the twentieth of March. If they were harder to grow some persons would think more of them. They only require to be dibbled into the soil in the fall an inch or two and they will blossom just as surely as the season will return. Several weeks of pleasure can be had from these early flowering bulbs before the herbaceous plants begin to bloom. Plant



LEUCOJUM VERNUM

them on the terraces and near the steps and foundations of the house where they will be enjoyed by all. In such situations they blossom early and for later succession plant colonies of them where they will flower later. The florist can multiply his customers by a lavish planting in every vacant spot around the greenhouse and salesroom.

THE FIRST TO BLOOM

On the fourteenth of January of this year in a warm sheltered nook we beheld the first snow-drop and it recalled to our memory the words of the poet:

"Already now, the snowdrop dares appear,
The first pale blossom of the unripened year;
As Flora's breath, by some transforming power,
Has changed an icicle into a flower;
Its name and hue the scentless plant retains,
And winter lingers in its icy veins."

There are about eight or ten species of snow-drop, but the two kinds that give the most satisfaction in our garden are the common snow-drop, *Galanthus nivalis*, and the giant snow-drop, *Galanthus Elwesii*. The snow-drop is a true winter flower and *Galanthus nivalis* is so cheap that it ought to be planted in large colonies. It is hardly credible that in this northern latitude the last flowers out of doors last year disappeared during the last weeks of November and the first flowers of this year appeared in the middle of January, thus leaving only six or seven weeks without flowers out of doors.

SOME DESIRABLE VARIETIES

The giant snow-drop, *G. Elwesii*, is by far the largest and finest species and gives satisfaction here. It is as

easy to grow as the common snow-drop and much more effective. Other kinds we grow are *Fosteri*, *Ikarae*, *Imperati*, *latifolius*, *plicatus* and *robustus*, *praecox*. A slightly shady, cool, moist spot makes a congenial home for them and if given these conditions they will grow and increase.

THE CHIONODOXAS

The *Chionodoxas* or "glory of the snow," are early spring flowering bulbous plants of exquisite beauty and are capital for massing effects. They are not fastidious about soil and will grow in almost any situation. The cream of the genus is *Chionodoxa gigantea*; it has larger flowers than any of the species or varieties and I can heartily recommend it as a first class garden plant and of the easiest culture. There is a white variety of this species which is rare and expensive. *C. Lucillae* has slightly smaller flowers than the above kind, but is the most widely cultivated species. The white variety of this plant is also in bloom; it is rare, but makes a pleasing mass of white.

C. Sardiensis has much darker blue flowers although smaller than any of the other kinds. We grow *C. Tmolusi* but it comes into flower later than the other kinds.

THE SCILLAS

The Siberian squill, *Scilla Sibirica*, is a mass of blue flowers now but it is so well known that it needs no introduction. We can only say that no garden is complete without large masses of this charming early flowering plant. Its white variety is a little more expensive but it makes an excellent companion to the many blue flowers in blossom now. It grows and thrives just as well as the species. *Scilla bifolia* is not quite as well known as the Siberian squill, nevertheless it ought to have a prominent place. It is quite distinct from the Siberian squill. Its flowers are not quite as large, but there are more in the cluster. It has also a white variety which is blooming beautifully now. This species and variety loves a light sandy soil.

THE SNOWFLAKES

The snow-flakes are near relatives of the snow-drops and in fact they look more like large, overgrown snow-drops, than anything else. There are several species but the most common kinds are the spring snow-flakes and the summer snow-flakes. The spring snow-flake, *Leucojum vernum*, grows six or seven inches high and has large drooping flowers resembling large snow-drops. The tins of the petals are well marked with a green or yellowish spot. It makes a good border or rock garden plant and the photograph here reproduced shows a plant in our rock garden. The summer snow-flake is not in bloom yet, but it is about a foot in height and will be in bloom in about two weeks if the weather holds favorable. Snow-flakes grow well in any good garden soil.

Crocuses are in their glory in the grass and it is there they look their best. Other plants in bloom now are *Bulbocodium vernum*, *Iris persica*, grape hyacinths and *Fritillaria pudica*.

Robert Cameron

Botanic Garden, Cambridge, Mass.

British Horticulture

ARBOR DAY CELEBRATION

The "Arbor Day" movement has not yet taken a firm hold in this country as in the United States. Britishers are somewhat slow in adopting new ideas, even when the project has such commercial advantages to recommend it as is the case with the extension of afforestation. Mr. E. D. Till, of The Priory, Enysford, Kent, who is an enthusiast on this subject, has done his utmost to secure a general observance of "Arbor Day." For several years there has been a festival at Enysford, and the most recent one which I lately attended was of a highly successful character. The natural ornamentation of the village was augmented by additional trees, the planting being skilfully performed by four young lady students from the Swanley Horticultural College. Mr. Till enthusiastically directed the proceedings, delighted with the success which has attended his efforts in Kent. He has been considerably encouraged in his praiseworthy work by letters of commendation received from such notable men as President Roosevelt, Sir Oliver Lodge, the late Dean Hole, Sir John Cockburn and others. At a meeting held in the evening Mr. Charles Dawson, the originator of Arbor Day in Ireland, was one of the speakers. Had tree planting been continued in Ireland, he said, since the union, as it was before, owing to the liberal grant then made by the Irish Parliament, Ireland would be a very different country today. He strongly emphasized the importance of tree planting as a means of increasing the wealth of the country. The successful work of the lady gardeners and the importance of municipalities adding to the beauty of urban centres by tree planting was alluded to in an address delivered by myself. If other districts could secure a grafting of some of Mr. Till's zeal Arbor Day would make great strides in Britain.

CARNATION CULTURE

Truly, carnations now occupy a prominent position in the flower market at Covent Garden. One leading grower devotes 85,000 square feet of glass entirely to their culture, and he is able to have a continuous supply of bloom. Amongst the novelties he is sending out this season those from the American raisers are well to the fore. These include Afterglow, Winona, President Seelye, Defiance, Lawson, Enchantress, Red Chief, Sarah Hill, White Fair Maid, Splendor and Andrew Carnegie. The latter is a scarlet sport of Harlowarden but is not recommended by the grower this side as he considers there are better scarlets. Amongst the 1905 novelties Winsor is credited with being the best and it has gained awards from the Royal Horticultural Society and the Winter Flowering Carnation Society. Aristocrat is described as "in form, stem, habit and size nearer perfection than any carnation today."

W. J. H. Adsett.

Notes from the Arnold Arboretum

The past winter has not been a very severe one and has done but little damage to the more tender trees and shrubs at the Arboretum. This is particularly evident in the evergreen plants which show with very few exceptions no effects of frost at all. Among the Conifers we note that *Cephalotaxus Fortunei*, *Torreya nucifera*, *Thuyopsis dolabrata* and *Libocedrus decurrens* with the protection of only a few Pine and Hemlock boughs have remained perfectly uninjured. *Taxus baccata*, the European Yew, which in more severe winters is always more or less injured and of which we therefore have no large plants has remained quite unharmed. Much hardier is the Japanese *Taxus cuspidata* which has as yet never suffered by the frost and always kept its dark green foliage unchanged through the winter, while the foliage of the native Yew, *Taxus canadensis*, has turned to its usual brownish red winter color. *Taxus cuspidata* is therefore to be considered the best Yew for our climate; it is more vigorous than the other species though less graceful in habit than *T. baccata*. *Cryptomeria japonica* also has not suffered and even a small plant of *C. japonica* var. *compacta* has escaped injury.

Our young Cedars of Lebanon, *Cedrus Libani*, show not the slightest trace of injury and as they have during the last years proved their hardiness in the climate of New England, we may hope to have at last succeeded to get hold of a hardy race of this beautiful and famous tree. The seeds from which our plants were raised were collected in 1902 by Mr. Siehe for the Arboretum in the high mountains of Asia Minor where the ground is snow-covered during the winter and the climate is probably more severe than in any other locality in which the Cedar of Lebanon is known to grow. Our largest plants are now about three feet high and look healthy and promising; there seems to be no reason why they should not grow here also into such stately trees we admire so much in some old European parks. If this will be the case, the Cedar of Lebanon ought certainly to be classed as one of the most interesting and important introductions of the Arboretum.

Broad leaved evergreens have stood the winter almost equally well and only a few have suffered in exposed situations. Of Rhododendrons and Kalmias neither leaves nor flower buds have suffered in the least and we can therefore count on a splendid display at flowering time. *Leucothoe Catesbaei* has in open situations the leaves partly injured by the frost, while in the shelter of Hemlock Hill its foliage has retained its bright green color. *Pieris floribunda* (*Andromeda floribunda*) is known as hardy, but this year even *Pieris japonica* (*Andromeda japonica*) has neither flowers nor foliage injured; usually it suffers very much and we therefore have only small plants. It is a pity that this shrub is so tender, for it is the most beautiful of the Andromedas with its large pendent panicles of white flowers appearing early in spring.

Euonymus radicans has not suffered in the least last winter; its three most important varieties were described and figured in this magazine last year by Mr. Koehler in vol. 5, page 372 and vol. 6, page 441. The variety *Carrieri* seems somewhat more tender than var. *reticulatus* and var. *vegetus*; I noticed outside of the Arbor-

etum a plant of it climbing on a wall with all its foliage destroyed by the frost. Even *Euonymus nanus* has retained a large part of its leaves though they have turned to a purplish green color. Of the allied genus *Pachistima* the western species, *P. myrsinites*, has its foliage partly injured by the frost, while the eastern *P. Canbyi* is uninjured; both are low shrubs of little ornamental value, except for rockeries; the first resembles in foliage somewhat *Euonymus radicans* var. *reticulatus* and the second *E. nanus*.

The Inkberry, *Ilex glabra*, holds still all its leaves uninjured, while the Japanese *Ilex crenata* has the foliage partly destroyed by the frost in some shrubs and in others growing side by perfectly uninjured, which shows that individual differences in regard to hardiness exist sometimes in different plants of the same species; it is further interesting to notice that of the small leaved variety not a single plant has suffered. That *Ilex opaca* has stood the winter well is perhaps not necessary to mention.

The Box-trees, *Buxus arborescens* as well as *B. japonica* have not suffered in the least; the latter species is still little known; it is of a lighter pleasanter green, but does not grow as high as the first species.

Alfred Rehder

Pinus ponderosa or Bull Pine

This has several other names: Pinus Carigana, Pinus Engelmani, Pinus Jeffreyi, also Yellow Pine, Heavy Pine, and Montana Black Pine. Its habitat reaches from the Niobrara River to the Black Hills and from the foot hills of eastern Colorado to the Pacific slope, where it is sometimes called the Silver Pine and often the Yellow Pine. There, it reaches its grandest proportions, attaining a height of two-hundred feet. For our western prairie, our semi-arid regions, and for the great, bleak Northwest, it is by far the most valuable evergreen we have. In spite of its heavy foliage, when once established, it will endure without flinching a long series of dry years. I have made a close study of this tree for over thirty years and its hardiness, robustness, adaptation, and intelligence make it a remarkable tree. Never plant in any of the northern States seeds from the western slope. They make an utter failure wherever tried. If you want to plant on the western plains or in the semi-arid regions, get seed from the Colorado foot-hills. But should you plant trees from these same seeds in North Dakota, you would make utter failure, yet for all the Northwest, there is ample provision, for trees raised from seed from the high altitudes of the Rockies and the Black Hills are perfectly hardy. Ordinarily, this tree is a failure in the East. To make a success of it there, seed should be gathered from the highest belt growing in the Rockies where there is snow on the ground eight months in the year and much rainfall in summer.

ITS INTELLIGENCE

While in the mountains, after a succession of dry years, I noticed several groves on steep hill sides where

the water had nearly all run off, that were turning yellow and at a distance they looked as if dying. Come to examine them, I found that on account of the excessive drowth, they were dropping half their needles while the rest were fresh and green. They did not have provision for the whole family and so they were carrying just what they could. Down in the valley, two hundred feet from an irrigating ditch, there were the same kinds of trees with needles, long and glistening, of the healthiest green. I wondered how this could be as they, too, were on a steep hillside. Having occasion to dig beside the irrigating ditch, I found a mass of roots from those distant trees pumping up water and sending it to the topmost branches, keeping them fresh and green.

If you go into Northwestern Nebraska, you will see them perched like cliff dwellers on the tops of dry, inaccessible bluffs where the soil is too poor to raise grass. They are up there out of the way of fires. Were it not for this enemy, doubtless the plains of the West and the Sand Hills of the North would have been covered with them.

Nurserymen have not always succeeded with them and complain that they are hard to transplant, that the loss is heavy, and it takes years to recover from the shock.

AN IMPORTANT DISCOVERY

At this station, after years of careful experimenting, we have found a process by which you can raise them from seed as easily as you can peas, and you can transplant them with no more loss than with elm or ash, and you can grow them as easily as you can potatoes.

The trouble has been, we have grown them under screens as we have other evergreens, but they resent this; they do not want any coddling. The process is so simple any one can raise his own at small cost.

On a trip to the Black Hills, we noticed a lot growing near the railroad, on a spot where the soil had been scraped down to the hardpan. The seed had fallen in the autumn from the trees near by. These had been covered with snow. They sprang up early in the spring and there they were thick as they could stand. I took the hint, sowed a lot of seed out in the open in the fall, and never saw a finer stand. I found that by growing them without shelter, so they were used to the intense heat of summer and the cold of winter that they were so vigorous that I ventured to transplant them when a year old, and here I ran into another splendid success. The yearling plants had a heavy root system to support those long needles. You drift under the bed and get all the roots, which are twelve to fifteen inches long. Now dig a trench eight inches deep, straight on one side, set your plants against this straight side, double in the roots—for you need all—draw in the earth with one hand while you hold the tree with the other. After planting a while, take the hoe and fill the trench and stamp solid. After a day or two hoe or rake the surface to prevent evaporation. If there are no white grubs

and the ground is fairly moist and in good condition, you will save 95%.

A FINE SIGHT

I wish you could see our Ponderosas in all stages, those one year old, those one year after transplanting and you will acknowledge that our beautiful rows of three year olds, twelve to eighteen inches high, with their long glistening needles of freshest green are the finest you ever saw. We mention this process because we believe it can be made worth millions to the West and Northwest. A year ago, I sent a pound of seed to a man in Manitoba. He wrote he ventured to plant one-half of it and now had 3000 fine trees and was a green hand at it and this his first effort. If you can't get seed in the fall, make your bed in the spring, spade it up fine, rake it level, put on a pound of seed to eight feet square and cover with half an inch of fine loam or sand. It is best to soak the seed in blood warm water, changing every twelve hours to keep from souring. In about three or four days, they begin to sprout. Then plant and see they do not dry while germinating and you will be surprised at your success and will rise fifty per cent. in your own estimation.

In appearance this tree somewhat resembles the Austrian Pine, only the needles are much longer—sometimes ten or even twelve inches in length with a glossy polish enabling them to resist the hot winds. Under the above process, we have transplanted these trees when there was no loss in two exceeding hot and dry summers, when there was but four inches of rain during the summer months, with no irrigation. The roots are trained near the surface. If left alone they form a long tap root; for this reason, transplant when a year old and then you develop the most perfect root system.

What a pity these trees so easily raised cannot be planted on the semi-arid plains. Out there, with forests, groves, and wind-breaks, the hot and drying winds could be checked and dry farming could be carried on with success. Two years after transplanting, put them out where you wish them to stand in grove or wind-break. Some call them too coarse for the yard but I like them. Give them a chance to develop and they make a symmetrical tree. Their freshness in winter and sturdy growth make them very attractive. When once established, they make about two feet a year. They do not grow as rapidly as the Jack Pine, but they can endure the drowth and hot winds much better. If you have steep hillsides, inclined to wash, or rocky places you cannot plow, plant them to these pines. You cannot afford to have idle ground when land is worth \$100 per acre.

THE LUMBER

This is all right for framing and inside work. Exposed to the weather, it does not last as long as White Pine. For inside work, finished with hard oil, it is very beautiful. As it grows with great rapidity, the grain is quite coarse but when well polished it is about as attractive as any lumber we have.

A good deal of clear lumber will often be saved for frames and cornices. This is all right if well painted. We emphasize the importance of this tree for its many excellent qualities. Its ease of propagation and transplanting, its rapid growth, its drowth resisting qualities make it the most promising of all the evergreens for the great prairie States.

C. S. Hummer

Rhododendrons

Of all cultivated shrubs the rhododendrons undoubtedly occupy the premier position as the gayest and their value for landscape work is now becoming more generally recognized. Few subjects in the long list of our hardy shrubs, can show the improvement to be seen in the rhododendron of today, and much of this improvement has been achieved within recent years, through the enterprise and skill of such growers as the Waterers, who have devoted over half a century to the improvement of flowering shrubs, and to the rhododendron in particular.

It has always been a source of wonder to me that these beautiful shrubs are not grown on a more extensive scale. There are a great many people who believe that the best of the English hybrids cannot be grown in the New England States, but one has only to consult any up-to-date catalogue of varieties to be astonished at the large number of sorts that have proved available for planting in New England.

In passing, I cannot refrain from drawing attention to what I might call the trend of the times, so far as the planting and laying out of grounds is concerned. Very different are the fashions of today, compared with those of twenty years ago when sentinel yews, clipped conifers, and formal flower beds, were predominant and garden adornment was mainly of a formal nature. At the present day, a more natural treatment of lawns is being practiced, and dame fashion now points to flowering shrubs and herbaceous plants as being the more preferable material to use.

The laying out or planting of outside grounds, is not subject to any rules, and can never be reconciled to any fixed principle, but like many other branches of gardening depends largely on the natural surroundings, and perhaps more especially upon individual taste. The architecture, or outline of the dwelling is the primary consideration, for, although the residence may be from an architectural point of view absolutely perfect its ultimate effectiveness must depend to a great extent upon its setting. The accompanying illustration shows a case in point. A few years ago this beautiful little mansion was suffering the indignity of being surrounded with about a score of small mounds or "flower beds" of various designs. This method of embellishment was objectionably artificial, and quite disproportionate to the extent of the area involved. It represented nothing in nature, and by no stretch of imagination could we call it art. When it was decided to introduce a more natural and appropriate form of embellishment, rhododendrons were chosen as most suitable for this purpose. They were planted in irregular groups, at various points of vantage, where they could be seen from a distance across the intervening water and seldom have I seen a more charming picture.



RHODODENDRONS ON A SHADED LAWN

If one wishes to keep the beds gay after the rhododendrons have finished flowering, a very pretty effect may be obtained by a thick planting of *Lilium auratum*, which is a fine contrast against the dark green foliage. Small groups of this lily on the outskirts of shrubberies are very pretty, and they may also be used freely by the sides of woodland walks in the wild garden, or alongside carriage drives.

Regarding the best sorts of rhododendrons to grow, I might name dozens of varieties and rhapsodise over their various good points, but here I must content myself with naming a few sure hardy ones which are able to withstand our rigorous winters. *Everestianum*, a very free blooming variety, the color being rosy lilac, spotted and fringed; *Alexander Dancer*, bright rose; *Mrs. John Clutton*, one of the finest pure whites; *Concessum*, a beautiful clear pink; *Charles Bagley*, bright red; *Mrs. Anthony Waterer*, a magnificent pure white; *The Queen*, blush turning to white; *August Van Geert*, carmine, spotted claret; *John Waterer*, a very dark crimson; *Mrs. R. S. Holford*, a magnificent variety, the color being a rich shade of salmon; *Hannibal*, rosy carmine; *Lady Eleanor Cathcart*, light rose, spotted chocolate.

When planting rhododendrons, it is an important cultural point to remember that they will succeed in almost any soil which is free from chalk, or lime. In sandy loam the plants grow with as much vigor and luxuriance as they do in peat. Where the soil is of a heavy nature it may be rendered suitable for them by a liberal admixture of rough leaf soil. If the soil is poor coddling in a thoroughly decayed state forms one of the best manures for these plants.

They should always be kept well protected during the winter months. For the tops of the plants, evergreen branches such as spruce, are the best, and a good, thick covering of leaves between the plants will make an ideal winter protection.

Wm. W. Brown

North Easton, Mass.

HORTICULTURE

VOL. VII APRIL 11, 1908 NO. 15

PUBLISHED WEEKLY BY
HORTICULTURE PUBLISHING CO.
 11 Hamilton Place, Boston, Mass.

Telephone, Oxford 292

WM. J. STEWART, Editor and Manager

SUBSCRIPTION PRICE

One Year, in advance, \$1.00; To Foreign Countries, 2.00; To Canada, \$1.50

ADVERTISING RATES

Per Inch, 30 inches to page \$1.00.
 Discounts on Contracts for consecutive insertions, as follows:
 One month (4 times) 5 per cent.; three months (12 times) 10 per cent.;
 six months (26 times) 20 per cent.; one year (52 times) 30 per cent.
 Page and half page spaces, special rates on application.

Entered as second-class matter December 8, 1904, at the Post Office at Boston, Mass. under the Act of Congress of March 3, 1879.

CONTENTS

	Page.
COVER DESIGN—Easter, 1908.	
FLORA'S HARBINGERS OF SPRING—Robert Cameron—Illustrated	471
BRITISH HORTICULTURE—W. H. Adsett.....	472
NOTES FROM THE ARNOLD ARBORETUM—Alfred Rehder	473
PINK'S PONDEROSA—C. S. Harrison.....	473
RHODODENDRONS—Wm. McM. Brown—Illustrated..	475
NARCISSE AND DAFFODILS—Kenneth Finlayson....	477
TWO GOOD ANNUAL CHRYSANTHEMUMS.....	477
NEWS OF THE CLUBS AND SOCIETIES:	
Society of American Florists—New Jersey Flori- cultural Society—Detroit Florists' Club—Hortical- cultural Society of New York—Winnipeg Florists' Association	478
Florists' Club of Philadelphia—Southampton Hor- ticultural Society—New Bedford Hort'l Society..	479
Club and Society Notes.....	496
OBITUARY:	
Warren Ewell, portrait—Charles Ingram—William Griffin, portrait—Mrs. Bernard Beers—John David- son—George O'Brien—Samuel Gass—Christopher Hansjosten	480
HORTICULTURE AT UNIVERSITY OF MINNESOTA —Illustrated	480
SOME NEW THINGS IN AN OLD COUNTRY—J. Otto Thilow, portrait.....	481
THE CITY BEAUTIFUL—Mrs. E. S. Walker.....	482
PROPER SIZE OF A COMMERCIAL GREENHOUSE —W. H. Elliott.....	483
SMALL FRUITS—Wilfrid Wheeler.....	484
SEED TRADE	488
The Mann Bill—Government Seed Laboratory....	488
MORE ABOUT FORMOSA LILIES—Illustrated.....	490
POT ROSES FOR EASTER—Robert Craig.....	494
PICKED UP BY "WIRELESS".....	495
THE ROSE FROM A RETAILER'S VIEW—J. F. Sul- livan	497
OF INTEREST TO RETAIL FLORISTS:	
Simplicity and Harmony, Illustrated—Easter Sug- gestions	502
Easter Prospects—New Retail Flower Stores.....	503
FLOWER MARKET REPORTS:	
Boston, Chicago, Detroit, Indianapolis, New York, Philadelphia, Winnipeg	507
MISCELLANEOUS:	
National Apple Show.....	489
Best Ten Outdoor Rhododendrons.....	480
H. P. Rose Marshall P. Wilder—Illustration.....	483
Florists' Hail Association.....	486
Publications Received.....	487
Catalogues Received—List of Patents.....	488
U. S. Appraisers' Decision.....	490
A New Factor in the Plant Trade.....	496
Personal	499
News Notes.....	499-503-507
Plant Imports.....	500
Incorporated—Business Changes	504
A Liberal Offer.....	504
The Glass Market.....	516
Greenhouses Building or Contemplated.....	516

Again, Easter is with us—its inseparable worries and misgivings increased by the peculiar conditions prevalent in this disturbed year. In this, HORTICULTURE'S fourth annual Easter number, we extend to the florist trade, so indispensable to the proper observance of this vernal holiday, and to the seed and nursery trade without whose aid the people's spring would lose much of its charm, our earnest hope that the season may be in the fullest degree a joyous one for them, yielding profit and encouragement beyond anything experienced in the past. To the large and ever increasing number who have given us their support as subscribers and advertisers through the trying season just passed, we feel deeply grateful. For those who have seen fit to use the columns of this special issue to bring the attention of our readers to their spring offers we solicit the patronage of all who are pleased to see HORTICULTURE flourish. We know that the most enterprising and honorable firms in American horticulture are represented in our list of advertisers. Read what they have to say.

When Richmond first came upon the scene the prediction that it would in time supplant Liberty as a popular commercial cut flower was received with more or less doubt. That it would put even American Beauty upon the defensive was, however, something that its most ardent admirers did not dream of. Yet it has done so as florists coming in contact with discriminating buyers will testify and as is realized by those who have attended recent exhibitions and have made due use of eyes and ears. In fact, Richmond and Killarney, representing the highest development in rose growing in two continents up to the present time, seem now in a way to put all the favorite florist roses of yesterday into the background for good and to be practically the pioneers of a new generation of roses for a new generation of buyers, different in standard of type from any that have gone before. The advent of these superb varieties has injected new life into all departments of commercial rose industry and there is a certain satisfaction in knowing that neither one of them came into being through chance or haphazard experiment but were in each instance the product of long continued effort on well considered lines.

Having enjoyed opportunity on several past occasions to see what the Chicago retail florists are capable of doing in the way of table, drawing room and boudoir floral adornment we were much disappointed over the omission at the recent exhibition of the American Rose Society of any provision for displays of the decora-

Colored Plate with This Issue



NEW ANNUAL CHRYSANTHEMUMS
MORNING STAR & EVENING STAR.

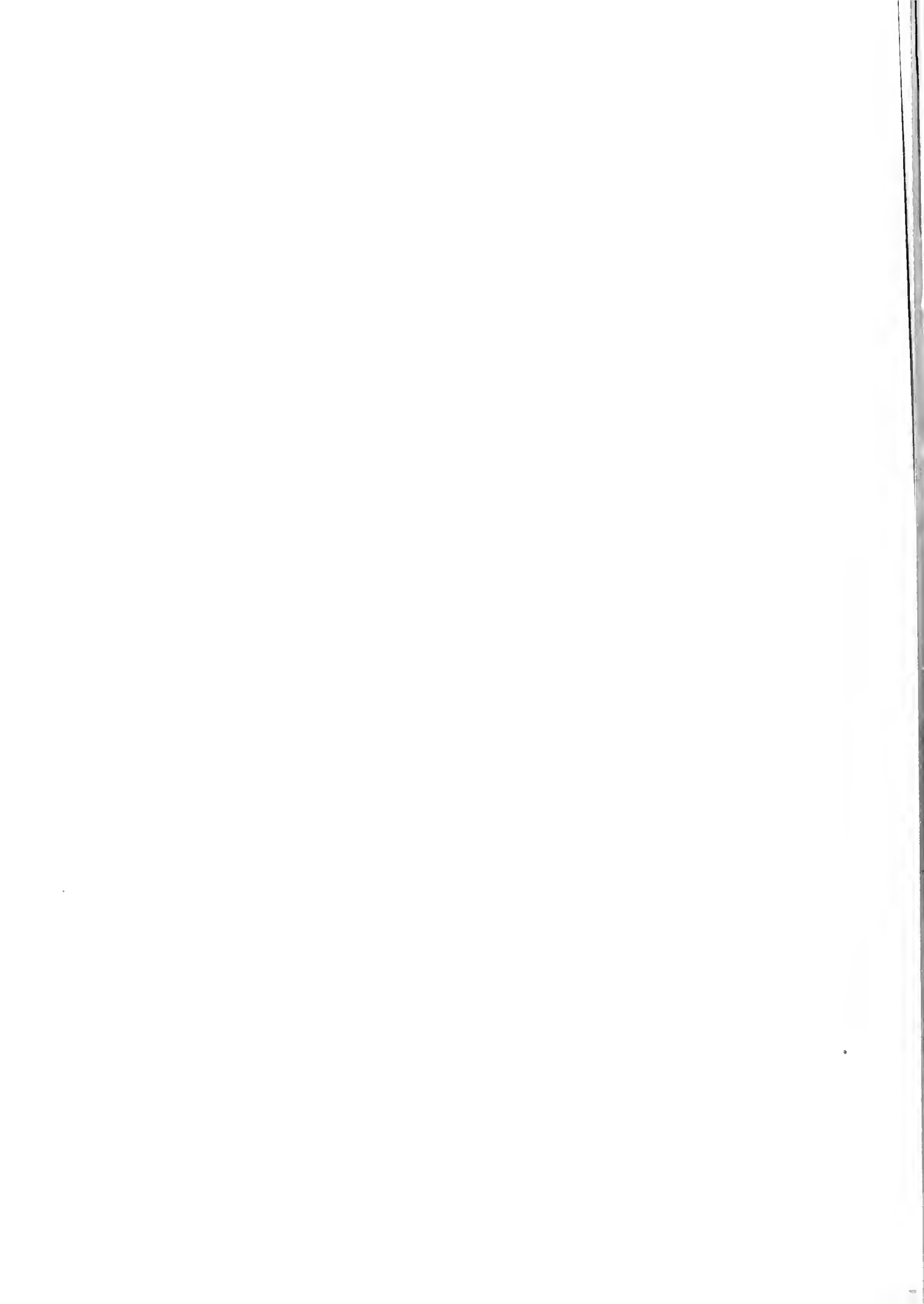

tive possibilities of the rose. All such exhibitions where the public are asked to attend, fall far short of their capacity for usefulness when they fail to make direct appeal to the public through displays primarily illustrative of the decorative possibilities and various uses of the material shown. The very generous list of special prizes offered for vases of roses—some of them duplications and others not competed for—might have been apportioned between the “technical” and the “spectacular” interests with distinct advantage to the general effect of the exhibition in question and with no little benefit to the rose industry. The growing of flowers of a high degree of merit is very properly recognized with premiums of great value and honor but flower growing as a vocation would soon lose its zest were it not that the public want to buy and make use of the product. Anything that increases this interest and use by opening the public eye to artistic floral possibilities and application must directly benefit the whole industry and particularly the grower and it looks like a monumental mistake when the floral decorator is not called in to supplement the excellent showing of the flower producer in the public exhibition hall.

Narcissi and Daffodils

It was with delightful pleasure that I beheld at our spring show just past, the evidence of better patronage bestowed on the short-crowned section of Narcissi “Mediocrinati” of Baker, which I regret have not hitherto found the deserved recognition they are entitled to in our broad country. In my opinion, in their many diverse and quaint forms, they possess more subtle charm than their individually more gorgeous brethren, the large trumpet daffodils “Magnicorinati.”

They are particularly effective and pleasing in large clumps in the herbaceous border and rockeries, and equally captivating in semi-shaded woodland margins of ponds, lakes and running brooks. Since they can be planted more thickly together than the larger trumpet section, on account of their smaller bulbs and less massive foliage, they thus offset the individual splendor of the larger ones by the greater number of flower scapes from a given space.

The section under consideration does not take so kindly to enriched soils as the larger daffodil does, and therefore should not be planted in ground newly enriched, especially by the use of the fresh and ranker stable manures. Bone meal seems to be conceded to be preferable to any other fertilizer and this moderately if longevity is to be looked for. Soot is desirable for its stimulating effects, as well as for its pungent properties for warding off insect encroachments, the most injurious of which is the larva of the Narcissus fly—“Merodon equestris”—the mature fly being exactly like a bumblebee in size and shape and hums and hovers about in similar fashion. I have come across a num-

ber of them on different occasions in the parks of Boston where practically no narcissi or but very few are planted, showing the wide distribution of the pest. The imagined inadaptability of many of the narcissi to our soil and climate, due to their aggravating disappearance at times, may in a large measure be attributable to the ravages of this pest rather than to peculiarities of climatic environment. The larva of this fly enters the base of the bulb and penetrates to the core, eating the latter away and causing the collapse of the bulb.

The Narcissi belong to the order Amaryllidæ. I do not know that because this is so the juices of Amaryllidæ proper possess the same properties as are found in the Narcissi, but I do know that the fly in question is equally partial, if not more so, to that class of bulbous plants, as I had an experience in that direction in common with a famous bulbous plant enthusiast in my neighborhood, our method at one time being to put out of doors our respective collections of *Hippeastrums* in late summer to ensure well ripened bulbs, but the ravages of this fly were so great that it drove us under cover with but little ceremony of protest after which, none, or comparative very little trouble was experienced by continuous growing and ripening of the bulbs indoors.

Considering the facts herein stated as regards the rapacious proclivities of this insect in the narcissus field, it would seem the part of wisdom and prudence in order to circumvent its further spread, to carefully examine all bulbs before planting, and ascertain that no larvae are present, by closely observing that there be no puncture in the cushion-base of the bulbs from which the roots are emitted. A bulb soft and somewhat spongy under pressure is to be regarded with suspicion and accordingly destroyed.

So much for the pleadings of the charm of the Mediocrinati section of Narcissus, ninety nine per cent. less than what might be said of them.

H. G. Dunlap

Two Good Annual Chrysanthemums

(See Colored Supplement with this Issue.)

Morning Star and Evening Star are two of the best forms of Annual Chrysanthemums. They are both of the Burridgeanum type and have the advantage over the original form of being self-colored.

Morning Star is of a delicate primrose yellow, while Evening Star is clear golden yellow; both growing about eighteen inches in height. They are most useful for cutting purposes, and may be grown in the summer garden or forced in the greenhouse during winter—for the latter use they are almost equal to the Golden Paris Daisy.

NEWS OF THE CLUBS AND SOCIETIES.

SOCIETY OF AMERICAN FLORISTS AND ORNAMENTAL HOR- TICULTURISTS.

Annual Meeting of the Executive Board.

The Executive Board met at the Prospect House, Niagara Falls, March 23 and 24. President Triendly and Messrs. McClure, Hallock, Wirth, Farquhar, Asmus, Young, Stewart and Rudd were present. Messrs. Kasting and Cowell were appointed to fill the vacancies caused by the absence of Mr. Murray and Mr. Beatty. The usual routine business was transacted.

The programme for the August convention was discussed and the main features decided upon, the details being left as usual to the president and secretary.

As the charter provides that the main office of the Society shall be in the city of Washington, the President was instructed to appoint an official representative of the Society in the city of Washington who should maintain such an office.

Mr. Hallock was appointed a committee to revise parts of the proceedings relative to school gardens, to make such additions thereto as seemed advisable and put them in shape for publication for general distribution, carrying out recommendations made by the Society.

It was resolved that the President of the Society be authorized to offer the silver and bronze medals of the Society at the horticultural exhibitions in this country for new and meritorious plants or flowers of American origin, provided that he is convinced that the exhibition at which they are proposed to be offered shall be more than local in scope and of sufficient extent to warrant recognition by this Society, no more than one medal to be awarded to the same plant or flower.

Chas. H. Keitsch of Buffalo having been nominated by the Buffalo florists, was elected superintendent of the trade exhibition.

The Secretary was instructed to correspond with the census bureau with a view to having the method of obtaining the census statistics in so far as they relate to floriculture more carefully considered and that certain changes be made which will render the results more reliable and more valuable.

Considerable attention was given the action of the Society regarding the nomenclature committee and registration, and it was the sense of the Board that the following out of the proposed course would entail an indefinite but large expense on the Society in the future, and therefore the Board could not concur and the matter was referred back to the Society for further consideration. It was the sense of the Executive Board that it was neither feasible nor desirable for this Society to attempt to fix the commercial value of any plant or flower under present conditions.

In view of the fact that it would soon be necessary to republish the by-laws, the committee discussed them in detail and recommended certain

amendments to be submitted to vote at the next convention, most of them being merely verbal corrections.

An examination of the treasurer's report showed that the Society now has in its permanent fund about \$5,200 and nearly \$4900 in its general fund. This showing was very gratifying to the members of the Board, and it was believed it would also be pleasing to the members in general.

The members were more than pleased with the hearty and cordial manner in which the local people assisted them in their work, and especially with the manner in which Mr. Cutler more than redeemed all the promises made at Philadelphia.

Practically the entire lower floor of the Cataract House has been placed at the disposal of the Society as well as the grounds adjoining. This will give ample space for the trade exhibition and the meetings under one roof and on one floor, and will also give room for the planting of flower beds for the exhibition of plant novelties. Mr. Isaacs, the proprietor of the Cataract and International Hotels, assured the committee that he would be glad to have any such planting done and would furnish without charge a competent gardener to care for the plants up to exhibition time. As these accommodations are all furnished without expense to the Society, it would seem that the financial results of the convention at Niagara Falls must necessarily be better than ever before.

Following the custom of some years past the accrued interest on both the permanent and general funds was ordered added to the reserve fund.

George W. McClure was appointed chairman of the committee on sports and J. R. Cloudsley was appointed as a member of that committee, the third member to be announced later. Mr. Ewing and Mr. Philpott of the Canadian Horticultural Association met with the committee on the last day and arrangements were partially completed for joint sessions of the S. A. F. and the Canadian Horticultural Society, details being left to be settled at a later date. The question of international games was left to the Sports Committee. It was decided that the bowling games should be held at Buffalo during the last day and evening.

The final resolutions which were adopted with enthusiasm expressed the appreciation of the Board for the "many courtesies shown us by everybody we came in contact with during our visit." Ex-Mayor Cutler and Mr. Isaacs of the International Hotel Co., and Major Butler of the Natural Food Co., and President and Mrs. Kasting were personally thanked in the final resolutions both for assistance offered and hospitalities extended, and the Board adjourned more than pleased with the kindness and courtesies shown and with the highest anticipations for a successful and enjoyable convention.

It should be noted by the members of the S. A. F. that Mr. Isaacs offered in case enough early reservations of rooms were made at the Cataract House to reserve the entire hotel ac-

commodations of the building for the members of the S. A. F. If this offer be taken advantage of, it will result in an ideal and unique situation in the experience of the Society. Trade exhibition, meeting hall and hotel accommodations all under one roof. The rates are from \$3.00 to \$5.00 per day, American plan, that is, meals included.

W. N. RUDD, Secretary

NEW JERSEY FLORICULTURAL SOCIETY.

At the regular monthly meeting of this society on the 3rd inst., an additional attraction to the usual display of the season's flowers was given by the W. A. Manda special prizes awarded by the committee as follows: 1st. William Reid, for a specimen Anthurium; 2nd. Popken & Collins for standard white lilac; 3rd. John Derwin, for a specimen Cineraria stellata. There was a table of orchids by Lager & Hurrell of Summit; hyacinths, by Thomas Jones of Short Hills; stocks, by Max Schneider; vases of roses, carnations, antirrhinum and sweet peas, by John Derwin. An interesting account of the formation of the new American Orchid Society was given by Henry Hurrell and a unanimous vote expressing the good wishes for its success and prosperity passed.

JOSEPH B. DAVIS.

DETROIT FLORISTS' CLUB.

The Detroit Florists' Club held a grand exhibit of Easter plants in connection with the last regular meeting. The principal plants shown were Baby Rambler, hybrid roses, spiraeas, azaleas hydrangeas. Special mention is deserved by Jas. Taylor, of Mt. Clemens, for beautiful snapdragon, Robt. Klage for bulbous stock, Kaiserin and La Detroit roses. The Department of Parks and Boulevards staged a very interesting collection of calceolarias. Philip Breitmeyer held the attention of the boys for a long time while telling of his recent trip south. Messrs. Robt. Rahaley and A. Sylvester, of the Michigan Cut Flower Exchange, staged all plants. A liberal lunch helped to impress the experiences of this banner evening more firmly in our memory.

FRANK DANZER.

HORTICULTURAL SOCIETY OF NEW YORK.

The regular monthly meeting and lecture of this society was held in the rooms of the American Institute, Berkeley Lyceum Building, 19-21 W. Forty-fourth street, New York City, on Wednesday, April 8, 1908, at 4 o'clock P. M. Mr. H. H. Saylor, Architectural Editor, Country Life in America, delivered a lecture on "An Architect's Views on the Use of Plants in Tying the House to the Landscape," illustrated by lantern slides.

THE WINNIPEG (MAN.) FLORISTS' ASSOCIATION.

The Winnipeg Florists' Association spent a most enjoyable evening on Thursday, March 26th, at the green-

houses of J. Riddle on Park Ave. Much business was discussed and by the reading of a paper by Mr. Muntenberg on the "Aim of the Association," which was greatly enjoyed. Seven new members were balloted on and accepted, and the meeting wound up with music, song and story, during which a dainty little repast was provided for the members by Mr. Riddle.

FLORISTS' CLUB OF PHILADELPHIA.

The monthly meeting of this club was held on the 7th inst. President Hahman in the chair. Robert Pyle of the Conard & Jones Co. gave an instructive address on advertising as applied to the horticultural business. The discussion which followed was a lively one, being participated in by such experts as Godfrey Aschmann, Robert Kift, Alexander Wallace, George D. Clark, J. Otto Thilow and others. A. Roper, Tewkesbury, Mass., exhibited a vase of Carnation Bay State, which came in for much favorable comment. A dwarf pink Lupin (*Lupinus polyphyllus Moerheimii*) was shown by Edward A. Strond. This is a soft pink in color, dwarf and compact in habit and would appear to be a promising subject for an Easter pot plant. The entertainment committee was instructed to arrange for a club smoker in the near future. Adolph Farenwald gave an interesting report of his experiences in Chicago at the rose show and dwelt particularly on the extent of glass devoted to roses in that locality and the up-to-date business system prevailing. Compared with what he supposed—it was simply wonderful, and made him feel a very small potato. In fact the speaker evidently felt during his recital that it would have been money in his pocket if he had never been born and that henceforth he would view his own achievements in a humble and contrite spirit. That old saw about travel broadening a man must have a hole in it somewhere when it makes him feel small like that. White Killarney rose from Waban was illustrated and commended by Robert Kift, who gave it as his opinion that in this we have as big an advance in white roses as occurred when the Bride was introduced.

NEW BEDFORD HORTICULTURAL SOCIETY.

About seventy members and guests were present at the annual banquet of this society on March 26, which was a pronounced success. The room was beautifully decorated with palms and ferns loaned by James Garthley, and the tables were resplendent with vases of Lloyd carnation, while at each place was one of the new crimson carnations of H. A. Jahn. Speeches and music followed the banquet. The committee in charge included James Garthley, H. A. Jahn and J. H. McVickers.

SOUTHAMPTON HORTICULTURAL SOCIETY.

The regular bi-monthly meeting of this society was held Thursday, April 2, President Clark in the chair. After routine business W. L. Jagger read a very interesting paper on Agricultural Education. The next meeting will be on Thursday, May 7.

U. G. AGER, Sec'y.

Obituary

Warren Ewell.

Once more comes to us the painful duty of recording the death of one of Boston's long-time florists, Warren Ewell, the last surviving member of the once widely-known firm of W. S. Ewell & Sons, died on April 2, aged



WARREN EWELL.

56 years. He was a member of the Massachusetts Horticultural Society, and an ex-president of the Gardeners' and Florists' Club of Boston. Up to within a few years he was one of the largest contributors to the spring exhibitions at Horticultural Hall, bulb forcing being his specialty.

Broken down and discouraged by business reverses and failing health during the past three years he has been missed from club meetings and other gatherings where he was so long a familiar figure, but many kindly inquiries for him have always been forthcoming and merry, lavish Warren's place in the hearts of those who knew him longest and best was never vacated. Very few of the famous aggregation of congenial gardeners and florists known as the Old Guard, who were so conspicuous in the annals of Boston floriculture in bygone years and of whom Warren Ewell was one, are now left. Younger hands have now taken up the local activities and will no doubt be found worthy successors of the pioneers who did their part so well. But for both young and old there never will be another Warren Ewell.

Charles Ingram.

Charles Ingram, gardener and florist, was found dead in his room at Wellesley, Mass., on Sunday morning, April 5. The medical examiner who was called stated that death was due to rheumatism of the heart. Mr. Ingram, who was otherwise of sturdy and athletic build, had been a great sufferer from rheumatism from time to time for many years. He was born of Scotch ancestry at Reading, England, and, by a notable coincidence, he is now buried at Reading, Massachu-

setts. His father was Edward Ingram, who was born in New Bedford in 1807. A young Charles Ingram in 1831 was regarded as a notable young florist, having been the foreman in some of the most famous gardens in England before coming to this country twenty years ago. He was at one time on the staff of the "Gardener's Chronicle" under Dr. Macosco, a position for which he had education and brilliant mind well equipped. His last professional position was with the late firm of Ewell & Sons, which he was connected with for several years with several florists supplying the locality of Boston and vicinity with S. J. Faxon, W. S. J. Ruggles, and other similar firms, and W. J. O'Brien, Wellesley Hills, being employed at the latter part of his career. His age was 50 years.

William Griffin.

The death of this accomplished gardener and contractor marks a valuable loss to American horticulture. He died, on March 26, at his home in Lakewood, N. J., was buried and expatriated, although he had been ill for several days. Indeed he was able to dictate matters of importance in his work on the afternoon of the day on which, a few hours later, he died. Mr. Griffin was in his 70th year. He was born in Kent, England, and came to this country when about 21 years old. He was a surveyor in England and also after he came to America, but soon became identified with garden and landscape work, which became the business of his life and in which he displayed great skill and taste. He developed Woodmere on Long Island, and afterwards went to Lenox, Mass., where he laid out and superintended with signal ability for several years the beautiful Elm Court estate of W. D. Sloane, and where his relations with brother gardeners from far and near were characterized by the kindest hospitality. Ill health compelled his



WILLIAM GRIFFIN

retirement to a sanitarium. After his recovery he entered the employment of Alex. McConnell, superintending landscape planting, etc., and later went to Georgian Court, Lakewood, as gardener on that noted estate. Mr. Griffin is survived by a widow, three

daughters and a son. He was fond of home life and indulgently devoted to his family.

Mrs. Bernard Beers.

Pauline, wife of Bernard Beers, of Denver, Colo., died on March 26, as the result of an operation. Mrs. Beers was a valuable assistant to her husband in his business for many years and was highly esteemed.

John Davidson.

John Davidson, the landscape gardener who laid out Pine Banks park, Malden, Mass., of which place he was superintendent from 1887 to 1904, died on April 1 in his seventieth year. He was born in Lanark, Scotland.

George O'Brien.

George O'Brien of Lenox, Mass., died on April 5, after a brief illness, aged 26. He had ably assisted his father in his greenhouses and had made many friends.

Samuel Gass.

Samuel Gass, a lifetime resident of Pittsburg, Pa., and for many years engaged in the florist business there, died March 26 at the age of 64.

Christopher Hansjosten.

Christopher Hansjosten, florist at Mt. Elliott Cemetery, Detroit, Mich., died on March 25.

NATIONAL APPLE SHOW.

One thousand dollars in gold will be awarded as a special prize to the grower of the best single apple exhibited at the national apple show in the Spokane (Wash.) State Armory, Dec. 7 to 14, 1908. The competition is open to the world. In addition, prizes aggregating \$14,000 and numerous trophies, medals, banners and ribbons will be hung up for exhibits in other classes.

Officers of the Spokane County Horticultural Association, headed by H. W. Greenburg, under whose auspices the exposition will be held, have completed preliminary arrangements for the incorporation of the National Apple Show Society under the laws of Washington, with a capitalization of \$100,000, which will be immediately subscribed by local people.

Growers in all parts of the United States and Canada, as well as Europe, will be invited to send exhibits for competition. Advices already at hand are that growers in the provinces of Nova Scotia, Ontario, Quebec, Alberta and British Columbia, and New York, Maine, California, Ohio, Michigan, Missouri, Iowa, Nebraska, Massachusetts and several other eastern and middle-western states will enter as contestants, and it is known that practically every recognized district in the Northwestern and Pacific states will be represented.

The primary object of the organization is to popularize the apple as the great national fruit, by creating a greater demand for high grade fruit at prices which will leave a profit to the grower without working a hardship upon the consumer. The plan is to educate the people to the knowledge that there is nothing more healthful than a good apple to begin and end the day. Thus will the apple come into its own as the king of fruits.

HORTICULTURE AT THE UNIVERSITY OF MINNESOTA.



Work in horticulture at the University of Minnesota is given considerable attention. It is given under two distinct heads. The first includes a course in horticulture extending over a period of two years in the high school of agriculture, in which there was an attendance this year of 582. Horticulture is required of all the students of this course. It is grouped under four heads, fruit growing, vegetable gardening, forestry and greenhouse laboratory work. The two first-mentioned subjects are largely explained by their titles. Forestry here includes only farm forestry, and ornamental planting in a general way. Greenhouse laboratory work includes actual work in budding, grafting, the making of cuttings, sowing seeds, packing plants, and other exercises, all of which is done in the greenhouse in the winter. To handle such a large number of students requires very careful systemization of the work.

The College of Agriculture is a continuation of the work begun in the school, or students may enter the college from other high schools. The courses offered in horticulture, in this college are fruit and

vegetable growing, systematic pomology, plant breeding, nursery work, greenhouse management and floriculture, landscape gardening. In the way of research work this department has a well-equipped greenhouse of about 2500 square feet, and thirty acres of land at the central experiment station, and two special fruit breeding stations embracing ninety-two, or a total of 122 acres.

The breeding of fruits adapted to the cold climate of Minnesota and adjoining states is a work of much interest to this department, and for which it receives liberal appropriations.

Professor Samuel B. Green has been in charge of the horticultural work at this station for twenty years. He has two special assistants in horticulture, two superintendents of fruit farms, and one foreman. He is a Massachusetts boy and a graduate of the Massachusetts Agricultural College.

THE BEST TEN OUTDOOR RHODODENDRONS FOR AMERICA.

H. Waterer of Philadelphia, on being asked to state which in his opinion were the most reliable rhododendrons in this climate, gave the following list: *Album elegans*, *Album elegans grandiflorum*, *Purpureum elegans*, *Purpureum elegans grandiflorum*, *Rosea elegans*, *Everestianum*, *Chas. Dickens*, *H. W. Sargent*, *Caractacus*, *Lady Armstrong*.

SOME NEW THINGS IN AN OLD COUNTRY, OR ONE MONTH'S OBSERVATION BY LAND AND SEA.

Read before the Philadelphia Florists' Club, March 3, 1908, by J. Otto Thilow.

(Continued from page 411)

We arrived at Bingen in the evening in good time for dinner, and thereafter took a trip through the town following its circuitous streets and winding courts. Early next morning we crossed the Rhine to Rudesheim, mounting the steep hills by cog roads, through the vineyards to the Niederwald, where a few hours sojourn and a walk through the woods, and then a study of the monster Denkmal, Germany's Victor Pride, satisfied us that the points of interest had been covered. As water was scarce, and we were not sure of its analysis, it was quite in keeping to indulge in a light lunch and pay homage to this historic spot by imbibing its famous product—Rudesheimer clear and refreshing. Another glimpse from the edge of the precipice and wall, the base support of this great monument, down the Rhine, with a panoramic view of this winding stream hemmed in by the ancient vineyards on its sides, gave us a deep and lasting impression of what Germany has cause to be proud of—"The German Rhine."

Frankfort.

We parted from this scene by noon on October 1st, leaving Bingen for Frankfort Germany. Two hours walk through the business streets of this city was pleasurable, and quite convincing that it was an active, business city, and up-to-date. The evening was spent at the Palmen Garten, enjoying an occasional visit to the vast glass structure covering some monster palms, and a beautiful garden. The rest of the evening was one of delightful music listened to by a large audience of Frankfort's music-loving people. Early the next morning we returned to this beautiful garden, and took a critical look at everything of horticultural interest. For precision, order and cleanliness the Palmen Garten is equal to the best. The glass houses are well stocked with interesting plants and a wealth of flowers. The grounds are beautifully laid out, and well broken up by groups of trees, shrubs and beds, which are kept in perfect condition through the growing season. The admission is one mark, and it is well worth this pittance for so instructive a lesson to a stranger, and so much enjoyment to one who can appreciate the vigilance it requires to maintain it in good condition.

Erfurt.

We left Frankfort October 2, arriving in Erfurt that evening after passing through some very interesting country, which showed that agriculture was carried on in the modern way, close cultivation in intense form. The long strips running toward the hills from which the crops had just been cleared, looked as though the soil had been run through a sieve; no weeds in evidence, all the available land was ready for its cover crop.

When reaching Zebra, a junction, the road takes an angle course over high elevations, directly east, which afforded opportunity to get a long view

of the Thuringian Forest in the distance to the eastward. Many villages and towns lay along the valley between the railroad and the ranges of hills. Nearing now the Saxon country gave me a slight inspiration, it being the land of my father's pride, and which I had for the first time the pleasure to look upon. The city of Erfurt needs no minute description, as it is known well to horticulturists the world over. The fostering of the seed-growing industry identifies this ancient German city with the whole world. My visit to Erfurt was the result of many a determined effort, this being the only opportunity I had of meeting face to face my numerous relatives, whose anxiety to see their American cousin was quite mutual. All that could be done to cover the ground in the forty-eight hours' stay was most courteously afforded by them. An auto trip through Gotha, Coburg, Friedrichsroda and to the Thuringian Forest was sufficient evidence that motoring is a delightful



J. OTTO THILOW

pastime, because of the splendid roads and the freedom accorded the autotist. The Germans might well point with pride to the well-kept forests, of which nearly 35,000,000 acres are in the German empire alone, 32 per cent. belonging to the State, apparently not a mis-happen tree to be seen from the roads. The resorts in these forests, or rest spots, are cozy and delightful to the tourist, offering the much craved-for refreshment and rest. This auto tour covered 110 miles in three hours; returning to Erfurt in the evening. Sixty minutes to the hour was hardly enough for so strenuous a time as was put in with these big-hearted people.

Beside the visiting of the historic points, a general look through the city was of intense interest. The next day, October 4th, we were invited to go with our friends to the historic city of Eisenach, west of Erfurt, and visit the famous "Wartburg" on the crest of the mountain, which has been standing for centuries overlooking the beautiful Saxon hills and valleys. After the winding road upward had been covered we responded to the call to make the inspection tour. Following the guide along the halls, through towers and narrow ways was a lesson

in very ancient history, concluding with a visit to the room once occupied by Martin Luther, and from his window the view down the mountain and along the valley is a panorama of rare beauty. After light lunch at the cafe we started on our winding descent down the mountain, and through the perennial garden, finally reaching Einach, where we again took train for our northeastern journey to Berlin. On our way we halted long enough at Erfurt to have our luggage thrown in through the open window, and bid farewell and separate from those with whom so short an association had made a deep and lasting impression.

Berlin.

Starting out early on the morning of October 5 we were at once struck with the order and cleanliness which seems to pervade this well-known city, and were reminded of the words of Burton Holmes in his introduction to his lectures on Berlin. "It were well if some of our American cities would send some of their councilmen, and mayor too, to Berlin and learn how they manage to keep a city clean." The ever-ready and present German cabby with taximeter was summoned for a ride through Brandenburger Thor to the Mausoleum at Charlottenburg, then back to the Sieges Allee—a marble congress of Kings, Prussia's rulers from Albert, the Bear, in 1170, to William the Great in 1861. The most noticeable features along this avenue and nearby were the well-kept beds of chrysanthemums with borders of ageratum, lobelia and alyssum. The most striking was the absence of the faithful French canna—it seems not to have the congenial conditions for its growth and development. A trip to the Court of Statuary facing the Palace ended that part of the day's sight-seeing in Berlin, the afternoon being spent at Potsdam, which is quite interesting, being the summer home of the Emperor. A trip to Sau Souci, and along the extensive gardens and glass structures out on the road leading to the old and new Palaces, and just before reaching the main entrance we saw the large iron grille gates, which were at the Chicago Fair, at one of the entrances to the grounds. Quite an interesting feature connected with this royal estate was the artificial ruin, built on a prominent point, rather effective, and at the same time transporting a scene as along the Rhine.

Hamburg.

The effort and exertion of trying to do Berlin in a day was quite a strain, but we were quite ready the next morning, Sunday, October 6, to leave for Hamburg, arriving there at 1 P. M. It might be said of Hamburg, a city of three-quarter million inhabitants, that its business activity, its brilliant stores, fine displays and very courteous clerk service and attention exceeds that of most other cities. The shopping districts are well supplied with florist shops, and what can be said of them as being of modern type and up-to-date in their display, is also true of the florists' shops in all the cities we had been through in Belgium, Germany and Holland. Most striking to an American visitor is their free use of the dahlia in even the most artistic designs, adhering mostly to solid, one-color effects, with ribbons and dyed

pass as accessories. The cut-glass vases in pots are among the foremost plants in decoration during the fall season, also scarlet geraniums with adiantums in designs of stunning effect. The show windows comprise two-thirds of the store stock in many cases, and are so arranged that the customer can walk about in the window among the display of designs and make their selection without disturbing the arrangement. A stop of nearly forty-eight hours in this city of industry was only enough time to become initiated into a few of the pleasures.

Amsterdam.

On Tuesday, October 8, we left Hamburg for the long journey to Amsterdam, passing through Bremen, then southward and changing at Osuabreck, moving direct west, reaching the Dutch Capitol at 5:30 P. M. Eager to meet directly the ancient and unchanged element and custom of the Hollander, we at once struck out to do the town as thoroughly as time would permit. In the most active business streets could be seen the life of all classes. With but few exceptions the streets had a gentle and easy curve, and when looking 100 feet ahead it appeared as if the upper-story dwellers should be able to shake hands from the windows of their respective sides. The houses along the older streets are nearly all out of plumb on the front—how it affects the interior we had no time to ascertain. The cause of this condition is said to be the sinking of the foundations—many of the culverts are close to the house-front instead of outside the curbstones.

With all the appearance of ancient conditions, yet there is a modern business activity equal to the largest cities. The florist shops along the busy street are just as modern in display as can be found anywhere; the style and good taste attract the eye and attention of the public. While it is a fact that effective methods of display have been long known in America among the aggressive florists, yet we must concede that there has been a simultaneous improvement along those lines in Europe to create a taste more for a natural than artificial in flowers, aided with the liberal use of ferns and graceful vines.

The train for the Hook of Holland left Amsterdam at 8:48 P. M., and was well loaded with passengers for England. Passing through Haarlem, The Hague and Schiedam, we arrived at the Hook at 10:48, where the boat was ready to cross the Channel to Harwich, England, which we reached at 8 A. M., October 9th, and London at 11 A. M.

The Closing Scenes.

Another half day in London permitted a visit to the longed-for Tower. Upon entering this labyrinth of gray stone, we followed sign boards, and were soon in its large halls, amid the show cases doubly secured with chains and locks, which contained precious stones and ancient garb worn by ancestors not of our kin. Onward and upward into other and confusing hallways and interior rooms of armor and trophies of war, ancient weapons taken from the fallen foe in distant lands centuries ago. Two hours among relics and beef eaters was quite enough, and highly interesting and instructive. The drill of the red jackets was very

entertaining, yet with the rigid discipline under which the British soldier is glad to serve. We had then to hasten away to Liverpool, where we boarded the "Arabic" and sailed at 5 P. M., October 10th. The stop at Queenstown afforded a great deal of mirth. The Irish lace and curiosity vendors boarded the ship, apparently under hazardous conditions, climbing its sides by ropes in order to reach the last few shillings left for mementos and curios. Those who were poor judges of lace satisfied the Irish merchants, who were mostly women, by buying a black thorn cudgel or cane.

The great and prevailing desire among people of all climes is to travel, go away from home, and see for the sake of seeing how things look, compare the conditions and customs of people, to see what others have that we do not have, to view natural curiosities, and profit by the change from our own environment. This tour, while it was to some extent over a beaten path of my traveling companion, who had taken previous observations at nearly every point covered, presented many new scenes unnoticed before, which afforded much pleasure. I desire to emphasize that the horticulturist without a doubt can and does glean more by traveling than those of any other profession because he works abreast with nature, and studies her resources, admires her productions, and loves the harmony produced in the landscape as well as in her flora.

THE "CITY BEAUTIFUL" MOVEMENT IN SPRINGFIELD, ILL.

(An Address by Mrs. E. S. Walker before the Illinois State Convention.)

The "City Beautiful" has become almost a household expression and is no longer considered a dream, a mere fad of the idealist; the interest in many directions is an established fact. The making of a more beautiful city is among the new arts. In the days of our forefathers the question of daily existence made too strenuous a life to give much thought to the artistic adornment of home or country. Now, when our republic takes high rank among the nations of the world, when peace and prosperity abound, the attention of men and women is directed toward the pursuit of this new art, the "city beautiful."

Interest in civic improvement in Springfield, Ill., was aroused by the meeting of the Civic Association of America held in Milwaukee, October, 1906. No one could fail to be impressed with the deep interest in this work exhibited by members present from Texas to Maine, California to New York, Philadelphia and Boston, men and women of broad intelligence, occupying high positions socially, giving of their time and talents in the interest of making greater and grander cities and towns in our own America. One of the results from attending this meeting was the inauguration of a "city beautiful" department in one of the local papers under the auspices of

the Women's Club of Springfield. The ground covered in this department during the period of its existence was: a cleaner city; the need of a good, pure water supply; the abatement of the smoke nuisance; the abandonment of obnoxious bill boards; a suggestion for securing a system of smaller parks; the cleaning up and cultivation of vacant lots, the care of back yards and alleys; the giving of more space in the erection of all new residences, for light and air; a plea for the elimination of all objectionable matter from the columns of the public press; the planting and care of trees; the duty of citizens in placing our public schools on a higher plane, both as to decoration, art studios and landscape gardening.

Our schools are centers of influence, they should take an active interest in the "city beautiful" movement; indeed they should be the chief civic centers of the community, since a problem is thrust upon us for solution, viz., the guiding of the future of the republic by the children of our homes as well as those born of parents coming to our shores from every foreign land.

The civic committee from the Woman's Club endeavored to interest the children of the public and parochial schools by instilling a desire to contribute to the general attractiveness of their homes and yards. Ten thousand copies of a suggestive circular were distributed to the pupils and eleven thousand packages of flower seeds were sold at a nominal price of one cent a package.

In addition to these prizes the daily newspapers offered cash prizes for the best essays written by the pupils of the 6th, 7th and 8th grades upon "What Children Can Do to Make the City More Beautiful." The Mayor issued a proclamation designating the first week of May as a special time for city house-cleaning. The results of this work were most gratifying. The climax, however, was reached in the great flower show. In this enterprise the Business Men's Association and the florists of our city took charge of the work and made the display a great success. The prizes awarded were trees, roots, bulbs and shrubs. A flower show upon a larger scale is among the anticipated events of the coming season.

Do you florists ever stop to think of the mission of the flowers you send forth? Of the brightness, of the good cheer they bring to the home life, and even when they cover the spot where rests all that is mortal of our loved ones, they there speak eloquently of the endless life. It is a beautiful thought that the sites of old colonial homes in New England, indeed almost the exact line of the old roadways, can be traced by the fragrant, blooming flowers which still persistently cling to life when the hands which planted and carefully trained them have been for many long years at rest.

In the distant and unknown future perhaps some flower may be culled whose fragrance shall serve to discover in the weedy, grass-grown ways of our lives, that in some work accomplished, some battle won of right over wrong, we too were counted worthy of remembrance. Any effort toward making the city beautiful can but make more beautiful the lives of its citizens.

WHAT IS THE PROPER SIZE OF A GREENHOUSE TO GROW ROSES FOR COMMERCIAL PURPOSES?

(Paper read before the American Rose Society by W. H. Elliott, Brighton, Mass.)

This is the question assigned to me. What I think is really wanted in this case is to know how large one really thinks a greenhouse should be built. My answer will be more on this line.

First, I wish to apologize for coming as an Eastern man to the city of Chicago to answer a question of this kind, for, if there is anyone who knows how large greenhouses should be, it is the Chicago man. I can, however, give you an answer in very few words. A greenhouse, for commercial purposes, should be as large as a man has money to build. That is, whatever money he is going to invest in commercial houses might best be put in one house. I would not hesitate to put 150,000 feet under one roof. In fact one could build a greenhouse to good advantage as long as it can be heated from central station. One can heat 100 feet each way with a gravity system, provided you had a fall of ten feet from the radiator pipes to the water line of the boiler. With a vacuum system I presume they might be carried a great deal further. Just how much I could not say, as I have not used that system. The continuous ridge and furrow houses need only be limited by the money to be laid out as the ridge could be carried 1000 feet each way. Much can be said in answer to the question of the advantages of the ridge and furrow houses as compared with the wide single roof. I shall speak in favor of the wide single roof, although I must admit that the well constructed ridge and furrow ranges around Chicago are as fine houses as I would expect to see anywhere, and I expect a strong argument in favor of that style from those using them. What influences me most in favor of the single roof is the snow.

Advantages of the Single House.

A roof that will clear itself of snow in mid-winter, at a time when the days are short, and prices high, is certainly to be desired. Another advantage to the single house is that it is easier to fill and empty; also that high houses are less expensive to heat. The variation of heat in the day time is not so great. They should be easier ventilated and handled. Larger amount of air space inside the greenhouse has proved to be an advantage rather than the disadvantage most growers supposed it would be. Mr. Holmes, in his address on "Rose Culture," before the Gardeners' and Florists' Club of Boston, stated as his opinion that 40 per cent. of the improvement in rose growing in the past twenty years was due to the up-to-date greenhouse, and I think he was right. It is one of the facts that we must accept that better stock can be grown in a large greenhouse than in a small one.

As to Width.

In regard to the width: It is hard to predict how wide greenhouses will be built in the next twenty-five years. Of course, with the ridge and furrow plan, the width is really unlimited, as the ventilation is taken

care of as you go along; but how wide do you suppose greenhouses will be built and depend upon a single run of ventilators to ventilate them? We have already seen them built up to 150 feet in width. Unfortunately, this wide house was not well constructed and is not considered a success, but it is really not the width. It is the question of construction. If a house was thoroughly and properly constructed could a house of this size be handled to advantage? I have not seen this wide house during the winter months; have no idea how the stock is growing. I looked this house over thoroughly at the time of the Convention last summer. It seemed to be considered an impracticable house. But the only reason given was the construction of the house. The question really is, if the house was strong and securely built would a house of that kind grow good stock? I would say that in that house at the time I saw it was growing as nice a lot of American Beauties as I could find anywhere. If the house will grow the stock, then that is really the vital question. The next question is, can a house of that size be constructed

and run as cheaply as a narrower house? There are a good many questions there that would need more knowledge and experience than I have had to answer. I cannot recommend the construction of houses of any such remarkable width. Sixty feet wide, with a pitch of six inches to the foot, I find to be thoroughly satisfactory. I would not hesitate very much to increase this width considerably, but, as soon as I increase that width, I must splice my bars, which I have not done on any of my large houses. Ventilation seems to be good. The air in these large, high houses always seems better than in the small ones. I do not quite understand why we need to ventilate greenhouses except to reduce the heat.

Should the air in a greenhouse keep pure and good without being renewed? If not, what is it that spoils it and should it not be much more serious in houses with much less air space?

Some Drawbacks.

I think it only fair that I should state what seems to be the most serious drawbacks in the construction of these large houses. In the first place, the unequal expansion of ridge, purlins,



MARSHALL P. WILDER

Courtesy Elwanger & Barry.

plates and sills. It is also a long distance to drive around them with a cartload of soil; leakage is increased if roofs are not kept in the best of repairs. There is also great danger from the wind, in houses of this size. The movement of so large a body of air as is contained in these houses strains the glass much more from the inside than in the smaller houses. They need to be built strong and glazed thoroughly. I have made up my mind to double nail the glass at the end of these houses.

As to Construction.

Horticultural builders charge more to cover the same ground with houses of this kind than they do with a number of smaller houses. They are right in this for they need stronger and more thorough construction. I do not like the iron frame with heavy rafters for this construction. We must guard carefully against the enlarging of our houses without properly strengthening all parts. My first large houses were weak in the outside walls. Thorough and permanent construction is what is needed, for many reasons. Not alone on account of wind and weather, but because this business has grown to be permanent and important enough to have a place of its own and not built up with the idea that it will some day be torn down and the land used for building purposes. A man building a factory don't have any such idea and our establishment should be just as permanent, or more so, as any factory. A proper location should be selected with great care; then get the best to do with and build thoroughly enough that the place can be inherited by your children and grandchildren. The fact that the growing of cut roses as a business was born inside of the last fifty years is no reason to suppose it will die out inside of the same time.

While I am wandering away from the question, allow me to impress on you the importance of taking the best of care of your house when built, especially in regard to painting.

SMALL FRUITS.

A paper read before the Vermont Horticultural Society by Wilfrid Wheeler.

(Continued from page 280)

Prepare Bed One Year Ahead.

It is best to prepare for strawberry bed at least one year before you are ready to plant it, breaking up sod and planting it to corn, or some crop which will keep the ground well stirred up, and rid it of weeds,—after the corn is harvested cut all the stalks in early September if possible, manure the ground—20 cords per acre is almost about right—and plough in the manure at least six inches deep. Harrow the surface of the ground and immediately sow rye or winter wheat for a cover crop. This is one of the most important steps in preparing land for fine crops, for this cover crop keeps the soil from washing, from deep freezing and thawing, and above all retains a great deal of the natural soil fertility. In the Spring, when you are ready to set your plants, the rye will perhaps be six inches high. Plow it under and at the same time you will bring to the surface the manure which you applied in the fall and which will now be in

the best condition and position for the roots of the newly set plants.

Another method of getting ready for a strawberry bed is by sowing a couple of crops of buckwheat the year before the bed is to be planted, and these together with some manure the same proportion as mentioned before will put the ground in excellent condition. Always keep in mind that soil well prepared is one-half the fight. In this method of soil preparation as in the other, do not plow the land in the spring until ready to set your plants, for the surface of the soil dries out very fast, and it is useless to plant in a dry soil unless rain is certain. After plowing, harrow the land and get the soil as fine as possible, and it is well at this time to harrow in a good dressing of lime about one ton per acre, but do not apply fertilizers now. Far better results are obtained from adding fertilizer when the plants are growing during the summer. It is impossible for the roots of a newly set plant like the strawberry to take up an adequate amount of nourishment from a highly fertilized soil, but this same plant will stand lots of feeding later on. A dressing should be applied about three weeks after the plants are set out, one thousand pounds of wood ashes and five hundred pounds of bone per acre to be followed a week later by a dressing of at least five hundred pounds of tankage or dried blood per acre.

Varieties and Culture.

It is best to have your plants all ready to set as soon as the field is smoothed off. But from the large number of varieties of strawberry plants that are offered for sale you will perhaps want to know something about the best to plant. While it is impossible to give exactly the kinds best suited to your soil and situation, most of the more productive ones readily adapt themselves to all soils and conditions. Perhaps quality cannot be the first consideration of the market grower.

For varieties it is best to choose at least four, and for market or shipping, all things considered, Abington, Sample, Elm Mary and Senator Dunlap are a good combination. For the home garden it is desirable to consider quality, and Marshall, Brandywine, Cardinal and Wm. Belt will produce fine, large berries. Of course soil conditions should be considered to some extent, and it may be best to try a number of varieties by degrees, selecting the ones best suited to your individual needs. Before setting the plants in the bed, trim off at least one-half of the leaves, and cut the roots well back, so that the new roots will get a good start. Do not set the plant any deeper than it grew in the original bed and be sure to firm the soil well about its roots. After the plants are set, keep the cultivator going and supplement the horse work with hand hoeings and weed pullings. Cultivation should continue until the middle of September, and then the plants may be left to harden before cold weather comes. In many varieties numerous runners will have to be cut off in order to get a good fruiting bed later on, for if all the runners are allowed to set and make plants the fruit will be small and poorly colored. Keep in mind that you want big, healthy crowns with plenty

of air space about them, so thin out surplus plants and give those which are left your best attention, and the picking question so troublesome in some places will not be so much trouble to you as one man can pick in a day twice as many large berries as small ones. Protect the plants in the late fall with coarse litter or leaves, remembering that you do not want to keep the frost out of the ground but rather in after it is once there, so cover lightly and remove the mulch in the spring as early as possible after danger of heavy frost is past. At this time apply dressing of wood ashes and later on, if the foliage is deficient, a little nitrate of soda or guano at the rate of 200 lbs. of nitrate or 100 of guano to the acre. Keep the cultivator going and remove all weeds until the fruit is formed, after which put on a mulch of straw, litter or leaves about the plants to keep the fruit clean and retain the ground moisture. This mulch will improve the fruit 50 per cent., and especially in a dry season when the plants need all the moisture they can get. Another advantage is that during rain the berries are kept from being spattered with mud or sand.

Picking.

Having brought your crop to this state, go over the bed at least every day and pick all ripe berries, breaking them from the plant with a stem. Use only new quart boxes, which can be obtained as cheaply as old ones, and it never pays to put good fruit in old boxes. Make two grades of fruit in picking, for there is always a demand for both kinds, and it will be found profitable to sort the fruit at the time of the picking, letting each picker use two boxes. The berries should be kept out of the sun and removed to a cool place before being packed. I might suggest that all picking should be done as early in the day as possible before the dew is off the plants; the fruit is harder at this time and will carry better, and it is a mistake to think that strawberries will spoil when picked wet. I know the question of strawberry pickers in country districts is often a perplexing one, and perhaps explains in a large measure the small amount of strawberries which are grown in these localities, so plan to make whatever ground you plant produce a large crop of fine fruit and reduce in this way the amount of hand labor in the picking season.

If you are near a small city or large town you may not be troubled in this way and your acreage can be increased accordingly, but every one must be the judge of his own conditions. If your market is near by do not pack the best berries in crates but have some long trays made to hold 20 or 25 boxes. The fruit packed in this way will not be crushed by the weight of the other boxes and will appear to a better advantage in the market. Your second class berries may be packed in crates as they can be shipped to more distant markets if there is no sale for them near by.

For the home fruit garden it is often more convenient to plant pot-grown strawberry plants in the late summer or fall. These plants when grown in hills will produce a good crop the next summer. The preparation of the soil

Chrysanthemum Novelties

And all Standard Varieties.

I have never been in such good shape to fill your wants in this line. The variety and quality is not equalled by any grower in the country.

...1 Catalogue Over 275 Varieties...

of the choicest the world has produced.

ROSES.

Rhea Reid Mrs. Jardine
\$4.00 per dozen; \$35 00 per 100.

Grafted Brides, Maids, Richmond, Killarney, 2½ inch.
\$1.00 per 100; \$100.00 per 1,000.

Own Root Brides and Maids,
\$3.00 per 100; \$25 00 per 1,000.

Begonia Gloire de Lorraine, 2¼ inch very fine,
\$2.00 per dozen; \$15 00 per 100

Charles H. Totty

Madison, - - - N. J.

If you KNEW what a saving in time and money

The Wittbold Watering System

will give you, you would write today for full information. 20 nozzles and 1 swivel wheel will equip 100 feet of pipe and can be bought for \$5.00. Send for full information and booklet.

E. H. HUNT, General Agent
76-78 Wabash Ave., CHICAGO

for strawberries applies to all the small fruits but it will be found of benefit to prepare the soil deeper for gooseberries and currants and while these latter fruits will do well in almost any soil, they are more profitable if given a deep rich soil with plenty of bone meal and wood ashes worked into it.

Raspberries and Blackberries.

Raspberries and blackberries white not as important as the strawberry are worthy of more extended cultivation and should demand greater attention from horticulturists. These fruits are not as hardy as the strawberry and therefore need more protection during our cold winters. It is often found necessary in sections where there is little snow to lay the canes down and entirely cover them with earth. The raspberry which is a very important crop in Central New York, is grown too far from the markets to ship in the fresh state, so large areas are given up to the growing of raspberries for drying. The fruit is then sold at about 20 cents a pound, often returning the growers some 350 or 400 dollars per acre. It would seem as if there were parts of this state where such an industry would be profitable. Both blackberries and raspberries are better grown about six feet apart each way so that the ground can be more easily cared for and the first year at least some root crop such as carrots, beets or turnips can be planted between the rows.

Blackberries and raspberries like a good firm soil and do much better when planted on a hillside where the land is more or less springy. It is

best to support in some way the fruiting canes of these bushes and a simple device for this is to drive a strong stake into the centre of a clump of bushes, nail two cross arms on the stake and tie the canes to this stake.

When the fruiting season is over remove all dead canes and burn them. For varieties in raspberries, Cuthbert, Herbert and Worthy for red, Kansas, Gregg and Ohio for black, Columbian and Shaffer for Hybrids; blackberries, Snyder, Agawam, Ward and Dorchester.

The Gooseberry.

At one time not long ago the gooseberry was almost unknown in many of our gardens, and hardly ever seen in our markets and to many of us today it is a fruit unappreciated and neglected, but there is a future for the gooseberry. When it is thoroughly known it will outclass the currant in popularity and profit. We are only just beginning to realize its value. The

gooseberry can be grown farther from a market than any other small fruit and yet be sold at a profit, for it is usually shipped green and there is therefore no loss in transit. Gooseberries seldom sell for less than 10 cents a quart and if 10 quarts can be grown to a four-year-old bush, you can readily figure up the profits from the nature of this fruit when the bushes are set 6 by 8 feet apart making about one thousand bushes to the acre. Also gooseberries may be set among your young orchard trees giving an additional value to the land.

Currants may be set in the same way but being a more perishable crop could not be marketed so readily, though they can be used at home in the making of jelly, etc., which can be sold to the city people who are willing to pay a good price for a pure article.

Many of the farmers wives in New England are getting a very good income from the preserving of fruit which they sell at a profit even great-

HARDY NURSERY STOCK

ORNAMENTAL and FRUIT TREES

Shrubs, Roses, Vines and Small Fruits

We make a specialty of supplying Florists' Trade, growing a complete line of everything that is hardy in the Northwest. Plants put up separately or in bulk, as they may desire. Full Line of Hardy Perennials. If you have not received our Wholesale Price List, write for it at once, or send list for Special Prices.

L. L. MAY & CO.,

ST. PAUL, MINN.

Daily Auctions

EVERY MORNING AT 9 O'CLOCK

We offer without reserve

Palms, Bedding and Decorative Plants, Bulbs, etc., etc.

FROM LEADING GROWERS AND IMPORTERS.

In lots to suit the **WHOLESALE TRADE.**

TERMS CASH.

NOTE. Special preparations have been made to handle exceptional quantities of Easter plants, and the trade is hereby advised that our methods and facilities provide for *prompt delivery.*

CATALOGUES ON DAY OF SALE.

The FRUIT AUCTION COMPANY, cor. Franklin and Washington Sts
NEW YORK CITY

P. O. Box 640.

Telephone 1512 Franklin

er than the fresh fruit. Both gooseberries and currants need careful pruning and care to get the best results. All three-year wood should be removed from the bushes and just enough new cane left growing to insure the life of the bush. For varieties, Fays, Cherry and Perfection in currants are best; Downing, Triumph Chataqua, Industry and Red Jacket in gooseberries.

Freedom from Insects and Diseases.

Probably these small fruits taken as a whole are freer from insect enemies and diseases than any other class of fruit, but it is also true that they have very serious enemies which need careful attention or the crop will be ruined. The strawberry is attacked by a white grub and the root of the growing plant eaten off before you know anything is wrong. This pest can be controlled by a rotation of crops, never allowing strawberries to follow grass or potatoes without some other crop between. Leaf blights and rust can be prevented by spraying with Bordeaux. Currants and gooseberries are both attacked by the currant worm and what is far worse the San Jose scale. The former can be killed by the use of arsenate of lead or hellebore while the latter requires more stringent methods. An application of lime, sulphur and salt or some of the more recent soluble oils is found to be efficacious. Raspberries and blackberries are both much benefited by spraying with Bordeaux for leaf diseases but where rust appears the diseased cane should be cut out and burned and in bad cases the roots

and all dug out and destroyed. All small fruits are greatly helped by spraying with Bordeaux even if no disease is apparent and it certainly pays, for in the increased vigor of the plant or bush will come a corresponding increase in size and beauty of the fruit.

Keep in mind that to get large, fine fruit, you must have plenty of sun and air about the plant. Spraying and pruning must be thoroughly attended to, and above all the cultivator should be kept moving among the plants and bushes in the warm summer months.

Not alone should these small fruits, which add so much to the joys of living, be grown for mere profit, but also for the pleasure and experience that one can get from a healthful occupation in God's open air.

Interesting the Boys.

Many of you are no doubt often at a loss to give your boy an interest in the farm work. You often see him drifting away from the farm to the factory, to the city and to the mill, when if the farm had been made more attractive he would no doubt have become attached to the place and stayed at home in a more healthy, moral and physical atmosphere. Right here I believe that the small fruits have a mission for the farmer's boy, and can be made more interesting than the growing of hay, corn and potatoes, and the child can begin at them when he is quite young. So set aside a place on the farm and give it to your boy, and let him till this and have the income from a bit of land as well as the fun of growing some nice fruit for the table.

HAIL RECORD.

Recent losses are reported by the Vineclad Greenhouses, Boonville, Mo., amounting to \$500; C. Schlensker & Sons, \$3,000; H. Steicker, \$3,000; Meyer Bros., \$3,000, all of Indianapolis, Ind.



**OUR ANNUAL
Good Friday's Sale**

Will take place on 17th at Noon,
consisting of flowering plants suitable for Easter.

W. ELLIOTT & SONS
201 Fulton St., New York

DREER DAHLIAS

We can still supply in undivided field-grown roots, varieties as listed below. All are desirable cut flower sorts.

	Per doz.	Per 100		Per doz.	Per 100
A. D. Livoni (Quilled, Pink).....	\$4.00	\$ 8.00	Grand Duke Alexis (Quilled), Ivory white.....	\$11.00	\$38.00
Aegir (Cactus), Cardinal red.....	1.00	8.00	Henry Patrick (Decorative), White.....	1.00	8.00
Alba Superba (Single), Fine large white.....	1.25	10.00	H. W. Silem (Cactus), Cardinal red.....	2.50	15.00
Arabella (Show), Light, sulphur-shaded peach.....	1.25	10.00	Harbor Light (Cactus), Brilliant cochineal red.....	2.50	15.00
Admiral Dewey (Decorative), French Purple.....	1.00	8.00	Horn of Plenty (Cactus), Deep carmine purple.....	1.00	8.00
Amos Perry (Cactus), Free fiery red.....	2.50	15.00	J. H. Jackson (Cactus), Crimson maroon.....	1.25	10.00
Bon Ton (Show), Rich garnet.....	1.00	8.00	John Thorpe (Show), Solferino rose.....	1.25	10.00
Black Diamond (Decorative), Purplish garnet.....	1.00	8.00	Kriemhilde (Cactus), Pink.....	1.00	8.00
Blackbird (Single), Black velvety maroon.....	1.00	8.00	Landrath, Dr. Schiif (Cactus), Rosy apricot.....	1.00	8.00
Chameleon (Fancy), Flesh, pink and yellow.....	1.25	10.00	Lenau (Cactus), Coral red and apricot.....	2.50	15.00
Cornucopia (Cactus), Vermillion carmine.....	1.00	8.00	Lynthurst (Decorative), Bright red.....	1.00	8.00
Capstan (Cactus), Soft orange scarlet.....	1.00	8.00	Time Alfred Moreau (Show), Pink.....	1.25	10.00
Cuban Giant (Show), Large bright maroon.....	2.50	20.00	Mrs. Roosevelt (Giant), Pink.....	2.00	15.00
Catherine Duer (Decorative), Red.....	1.00	8.00	Maroon Century (Single), Rich velvety maroon.....	2.50	20.00
Clifford W. Bruton (Decorative), Yellow.....	1.00	8.00	Miss May Loomis (Show), White suffused rose.....	1.25	10.00
Crimson Century (Single), Crimson and rose.....	1.25	10.00	Queen Victoria (Quilled), Yellow.....	1.00	8.00
Duchess of Cambridge (Show), Pink tipped crimson.....	1.25	10.00	Queen of Yellows (Show), Yellow.....	1.25	10.00
Else (Cactus), Amber and rose.....	2.50	15.00	Ruckert (Cactus), Bright red.....	1.00	8.00
Emily (Show), Solferino rose.....	1.25	10.00	Red Hussar (Show), Cardinal red.....	1.25	10.00
Fire-rain (Decorative), Brilliant red.....	1.00	8.00	Reliable (Cactus), Carmine and salmon.....	2.50	15.00
Frank Smith (Fancy), Maroon tipped white.....	1.25	10.00	Ringdove (Cactus), Carmine with white edge.....	1.00	8.00
Frau Hermine Marx (Cactus), Silvery rose.....	2.50	18.00	Scarlet Century (Single), Scarlet.....	2.50	20.00
Frute (Cactus), Peach and cream.....	1.25	10.00	Shooting Star (Cactus), Golden Yellow.....	2.50	15.00
Flora (Cactus), Pure white.....	2.50	15.00	Souvenir de Gustave Doazon (Giant), Pure scarlet.....	3.50	25.00
Floradora (Cactus), Blood red.....	1.25	10.00	Standard Bearer (Cactus), Fiery scarlet.....	1.25	10.00
Florence A. Stredwick (Cactus), White, fine form.....	1.25	10.00	Sylvia (Decorative), Soft pink.....	1.00	8.00
Fanny Purchase (Show), Yellow.....	1.25	10.00	Twentieth Century (Single), Pink.....	1.25	10.00
Grace (Single), Delicate blush.....	1.00	8.00	Uncle Tom (Cactus), Deep maroon.....	1.00	8.00
Gen. Huller (Cactus), Red, tipped white.....	1.00	8.00	Waltheri (Cactus), Sulphur yellow, white edges.....	2.50	15.00
Gottelinde (Cactus), Yellow.....	1.00	8.00			

One each of the fifty-nine varieties for \$5.00.

HENRY A. DREER, 714 Chestnut Street, Philadelphia, Pa.

The above prices are for the trade only.

PUBLICATIONS RECEIVED.

Bulletin No. 296, of the New York Agricultural Experiment Station, deals with the San Jose scale question.

San Jose scale is no longer a paralyzing foe to fruit growers. Its advent is feared; because only hard, careful work can prevent its spreading when once it gains a foothold; but for several years it has been possible to assure fruit growers that the pest can be quite easily and cheaply controlled on small trees by spraying with the lime-sulphur wash. Recent experiences by the Station and practical orchardists prove that similar methods, slightly extended and more thoroughly followed, will not only check the spread of the pest, but also prevent material harm from it, even in old orchards of large trees. The cost of spraying such trees with the lime-sulphur mixture and of pruning and trimming to make the spraying effective is inconsiderable when compared

500,000 Palmetto Asparagus Roots

2, 3 and 4 Years Old.

Well developed. Grown on Bloomsdale.
Trade Price, - \$3.50 Per Thousand.

No Order will be taken under One Thousand

D. LANDRETH SEED COMPANY, - - Bristol, Pa.
Bloomsdale Seed Farms.

with the loss due to spotting of fruit, weakening of trees and decrease of crop from the unchecked ravages of the scale. Full details of these extensive and successful experiments are given in Bulletin No. 296 of the Station. All owners of orchards of old trees in scale-infested sections would do well to study these experiments carefully.

The Director of the Station will send the bulletin to any address without expense, on application.

We have received from W. E. Bontrager, florist in the Dept. of Horticulture, Wooster, Ohio, a copy of Bulletin No. 190, on Evergreens. Their Uses and Culture. This is a very practical treatise, well-illustrated and its general distribution should accomplish much in developing an interest in the planting of this useful class of trees.

The Proceedings of the meeting of the American Breeders' Association at Lincoln, Neb., in January, 1906, is

just to hand. It is a bound volume of 260 pages. Many papers of great scientific value are included.

Financial Report of Lincoln Park Commissioners for 1907. Chicago, Ill. Full statement of income and expenditures in general maintenance and extension funds.

DAHLIAS. Now is the time to place your order for bulbs which will insure you getting named varieties in any quantity; prompt delivery.

DAVID HERBERT & SON,
Successors to L. K. Peacock, Inc.
ATCO, N. J.

100,000 DAHLIAS
Premium Stock, guaranteed true to name.

500,000 large Flowering Gladioli, hundreds of colors and variations mixed Wholesale prices on application. Order now for spring delivery. Catalogue free.
J. L. MOORE, Northboro, Mass.



The largest stock of thrifty plants in New England. All the New and standard varieties. The Dicky is the best one in sight. Buy your plants of the originator. I have been selling plants true to name for forty years. My catalogue is unique not like any other. Send for it.
C. S. PRATT,
READING MASS.

Does it Pay to Sow the Other Fellow's Aster Seed?

If other seed is as good as ours
is something we do not know
But we advise—the best kind for flowers
Bears the trade mark "ALTIMO."

Send to-day for Aster Book and Competition Card for the \$250 Prize Aster Growing Contest, Both Free.
ALTIMO CULTURE CO., = CANFIELD, OHIO

Seed Trade

The mild weather of the past two weeks has brought an almost insurmountable volume of business to New York and Philadelphia seed houses. The interruption of a couple of cold days at the end of last week was a happy event, staying the rush of orders for the time being and affording opportunity for overworked clerks to catch up and get on their feet again. Business is reported from all sides as equal to the best of other years and no complaint has been forthcoming thus far.

THE MANN BILL.

A meeting of representative seedsmen will be held in Washington April 21st to consider the Mann bill, which in the opinion of many will drive seedsmen out of business altogether. Others take the view that the bill as at present drafted would prove so impossible of enforcement, if enacted, that it would be de facto a dead letter. A prominent member of the Wholesale Seedsmen's League when seen recently said that after reading the full text of the bill he was inclined to think Mr. Mann was really making an honest attempt to be fair, but that the subject was so difficult much more harm than good would probably result with even the best bill that could be devised. To his thinking the seedsmen should make no effort to fight it. Nature does not produce perfect products and the farmer whom the Congressmen imagine they would please would in the long run suffer much worse than the seedsmen. It would be a case of the bull in the china shop—molling and maddling where no real necessity exists.

GOVERNMENT SEED LABORATORY.

The number of samples of seed received for testing has increased rapidly during the year. In many cases more than five samples a month have come from the same source. Up to the present time the number of tests made for one firm or individual in any one month for either mechanical purity or germination has been limited to five.

In order to meet the growing demand for this work, arrangements have been made to increase the number of tests for germination not to exceed ten in any one month. The number tested for mechanical purity will remain the same as formerly, not to exceed five a month.

EDGAR BROWN.

Botanist in Charge of Seed Laboratory.
Washington, D. C.

CATALOGUES RECEIVED.

Conrad Appel, Darmstadt, Germany.
—Catalogue of Forest and Agricultural Seeds, 1908. Illustrated.

I. N. Kramer & Son, Cedar Rapids, Ia.—1908 Catalogue. Covers a general line of seeds and plants.

Howard & Smith, Los Angeles, Cal.
—General Catalogue for 1908. A uniquely gotten up publication, adorned with half-tone pictures of high quality.

Henry F. Michell Co., Philadelphia, Pa.—Folder and price list of *Formosa Lilium longifolium*, "a decided improvement over any previous type of Japanese Easter lily."

Conard & Jones Co., West Grove, Pa.
—Trade Price List of 1908. Title page devoted to a fine portrait of rose Killarney. A very creditable publication in make-up and contents.

Harlan P. Kelsey, Salem, Mass.—American Hardy Rhododendrons: The Right Way to Grow Them. A good many other desirable things besides rhododendrons are described and illustrated in this pretty little catalogue.

E. G. Hill Company, Richmond, Ind.
—General Trade Catalogue for 1908. Here again Killarney, ever fair, beams from the title page. Many things of sterling value, including novelties in roses, chrysanthemums, carnations and geraniums, all of interest to the wide-awake florist, are illustrated.

Yokohama Nursery Company, Ltd., Yokohama, Japan.—This is a unique and very interesting catalogue. *Rosa Yessoensis*, *Nandina domestica* and *Prunus pseudo-cerasus* are the subjects of the colored cover illustrations and there are six handsome colored plates in the volume. It may be had for the asking by addressing the office of the company at 31 Barclay street, New

ASTER SEEDS

All Full Weight Packets Fertile 1907 Crop. **EXPRESS**—White, Violet, Rose. Trade Pkt., 1-16 oz., 25c; 1-4 oz., 75c; ounce, \$2.50. **QUEEN OF MARKET**—White, Light Pink, Rose, Lavender, Purple. Trade Pkt., 1-8 oz., 10c; 1-4 oz., 15c; ounce, 50c. **LATE BRANCHING**—White, Pink, Rose, Lavender, purple. Trade Pkt., 1-8 oz., 10c; 1-4 oz., 15c; ounce, 50c. **CARLSON'S BRANCHING**—Pink, Lavender, Early and Late White. Trade Pkt., 1-8 oz., 10c; 1-4 oz., 15c; ounce, \$1.25. **KATE LOCK**—White, Daybreak. Same price as Branching. **ROY L. PURPLE**—Trade Pkt., 1-16 oz., 5c; 1-4 oz., \$1.00; ounce, \$3.00. **VIOLET KING**—Trade Pkt., 1-8 oz., 10c; 1-4 oz., 15c; ounce, \$1.50.

Many other standard sorts in limited quantity. Write if interested.

ELMER D. SMITH & CO., Adrian, Mich.

York, and will be found very interesting as an example of commercial horticultural progress in the Flowery Kingdom, and also from the fact that many things unfamiliar to American cultivators are listed in it.

LIST OF PATENTS.

- 882,699. Electrical Receptacle for Plants. Harry S. Latshaw, Jersey Shore, Pa.
882,751. Runner Attachment For Plows. Earnest E. Edwards, Ithaca, Mich.
882,957. Cultivator. William L. Paul, South Bend, Ind., assignor to Oliver Chilled Plow Works, South Bend, Ind.
882,973. Weed-Cutter and Cultivator. Otto E. Slayton, Dillon, Okla.
883,000. Combined Furrow-Maker and Fertilizer Distributor. William O. Cumming, Macon, Ga., assignor to R. C. Hicks and J. W. Hicks, Macon, Ga.
883,006. Combined Cultivator and Planter. Henry H. Enns, Dietrich H. E. Enns and John J. Wiebe, Hooker, Okla.

RARE CHANCE—LATE SHIPMENT!

Reliable seeds for planting now. We have just received a late shipment, plump new crop seeds of our well known specially selected *Asneragus plumosus nanus* and *Sprengerii*, which we wish to move at once, and in order to induce quick sales offer at prices never before touched for this class of seeds.—

REDUCED PRICES

PLUMOSUS NANUS, per 100, 40c; per 500, \$1.75; per 1000, \$3.00; per 5000, \$13.75;
per 10,000, \$25.00.
SPRENGERII, per 100, 15c; per 500, 45c; per 1000, 75c; per 5000, \$3.00.

We are headquarters for the great new Easter Lily—**FORMOSUM**. Order quick. The supply is limited. Free from disease.

WRITE FOR OUR LATEST WHOLESALE CATALOGUE.

Henry F. Michell Co., 1018 MARKET STREET Philadelphia, Pa.

RELIABLE SEEDS---SOW NOW

Ageratum Mexicanum Blue Star — Tr. Pkt. 25c.; 6 Tr. Pkt., \$1.25.
Lobelia Erinus Pendiculata Hamburgia — Tr. Pkt. 30c.; 6 Tr. Pkt., \$1.50.
Primula Obconica Grandiflora — New Hybrids : Blue, Carmine, Pink, Purple, Violet,
 Pure-white, Compacta, Gigantea, Fringed Mixed Hybrids, each separate, Tr. Pkt. 50c.; 6 Tr.
 Pkts., \$2.50.

My Catalogue will guide you through Reliable Seeds. Ask for Same.

O. V. ZANGEN

SEEDSMAN,

HOBOKEN, N. J.

*Thorburn's
Seeds*

Seeds of ASPARAGUS PLUMOSUS
 NANUS, \$2.00 per 1000.
 Seeds of ASPARAGUS PLUMOSUS
 ROBUSTUS, \$2.00 per 1000.
 COLD STORAGE LILY OF THE VAL-
 LEY PIPS
 JAPAN LILIES, JAPAN IRIS

For prices, state quantities required.

J. M. THORBURN & CO.
 33 Barclay St., through to 38 Park Place
 NEW YORK

Best Quality Fall Bulbs

It is to your advantage to place your order early. Send us a list of your wants and we will quote you rock-bottom prices. Copy of our Florists' Bulb Catalogue will be sent upon request. Catalogues now ready.

VICK'S SUPERB PANSY SEED
 All the best varieties in separate colors
 VICK'S SUPERB MIXTURE

the best strain from all the leading named sorts
 1-8 oz. 75c. 1-4 oz. \$1.50 Ounce \$5.00
JAMES VICK'S SONS, Rochester, N. Y.

FISKE SEED CO.
 can supply new, to the florist for immediate use.
Aster Seed A Speciality
 Special Florist List Free

H. E. FISKE SEED CO.
 12 & 13 Faneuil Hall Square. BOSTON, MASS.

QUALITY SEED BULBS PLANTS
 SEND FOR CATALOGUE.
ARTHUR T. BODDINGTON
 348 West 14th St., New York.

LANDRETHS' SEEDS

**ONION
SEED**

EXTRA EARLY RED FLAT
 RED WETHERSFIELD
 DANVERS GLOBE
 STRASBURG YELLOW
 PRIZE TAKER

LOW
PRICES
ON
APPLICATION

BLOOMSDALE SEED FARMS, Bristol, Penna.

G. C. MORSE & CO.

Address all communications to our permanent address
 48 to 56 Jackson St., San Francisco, Cal.

The Largest Seed Growers
 in the United States

BRECK'S SEEDS

For Farmer, Market Gardener and Florist
 New Crop High Grade
 Catalogues mailed free on application

Joseph Breck & Sons Corp.
 47-54 NO. MARKET ST., BOSTON, MASS.

CAULIFLOWERS CABBAGE SEED

HJALMAR HARTMANN & CO.,
 12 Stormgade,
 COPENHAGEN, DENMARK.

Burpee's Seeds

PHILADELPHIA

Blue List of Wholesale Prices mailed
 only to those who plant for profit

Vegetable and Flower **SEEDS**
 reliable and Tested. Catalogue Mailed Free
WEBER & DON
 Seed Merchants 114 CHAMBERS STREET
 NEW YORK

JUST ARRIVED LARGE SHIPMENT OF High-Grade SCOTCH SOOT.

We have the Stott Double Nozzle
THOMAS J. GREY CO.
 32 & 33 So. Market St., BOSTON

BRIDGEMAN'S SEED WAREHOUSE

RICKARDS BROS.

Props.

37 East 19th St., - NEW YORK CITY

BRASLAN SEED GROWERS CO.

GROWERS FOR THE
 WHOLESALE TRADE ONLY

SAN JOSE, - - CALIFORNIA

BAMBOO CANES TOUGH AND STRONG

6 ft. long — \$1 per 100; \$6
 per 1000; \$11 per 2000

They cost about 10 per cent. more than
 other kinds, and they are 10 times better.

STUMPP & WALTER CO., - 50 Barclay St., New York

PRICES QUOTED IN THESE COLUMNS ARE FOR DEALERS ONLY

When Writing to Advertisers
 Please Mention Horticulture

YOU DON'T NEED TO
 Go outside of the
Advertisements in this Issue
 to get
Everything You Want
 for a big
EASTER BUSINESS.

Martial Bremond
 WHOLESALE GROWER OF FRENCH BULBS
 — OLLIOULES, FRANCE —
 A superior quality supplied at
 market prices. Shipments made
 direct. Cases marked to order.
 — Sole Agents —
RALPH M. WARD & COMPANY
 12 West Broadway - - NEW YORK

MORE ABOUT THE FORMOSA LILIES.

Horticulture Pub. Co.

Dear Sirs:—

Referring to our correspondence in your last number, we read with interest about the experience our brother growers have had with the Formosa lilies, and we would only like to add



FORMOSA LILIUM LONGIFLORUM

that contrary to the experience of the Hinode Floral Co. we found the size of the flower is rather what we would call pretty long, as you will see from the photograph we send you under separate cover, which was taken about two weeks ago.

Very truly yours,
SALTER BROS.

Editor HORTICULTURE:—

Referring to your correspondent's request regarding Formosa lilies in HORTICULTURE for April 4, would say that our experience with them this season has been satisfactory. The flowers are not so large and possibly not so numerous as in the old type but in other respects, notably health and earliness, the Formosa is much preferable to the old type. There is greater variation in height of growth, but we do not find that to be objectionable.

A. GRAHAM & SON.

Horticulture Pub. Co.,

Dear Sirs:—

As we are the original introducers of the Formosa Liliium Longiflorum, we think it will be of interest to your readers to state some facts about them, as there seems to be very little knowledge as to the origin of this comparatively new type.

As the Liliium longiflorum business is of the greatest importance for our concern in Yokohama, Mr. Uhei Suzuki, the founder and president of our company, did not spare either expense or trouble to bring a lily on the market that could compete in earliness with the Bermuda Harrisii. New plantations were started on different islands in the southern part of Japan with stock from our regular plantations in the vicinity of Yokohama, but they only resulted in entire failures and big losses of money because, although the lilies produced good bulbs, they did not give the desired results when forced.

Finally, Mr. Suzuki discovered on one island a wild-growing lily of the longiflorum type. He had the bulbs collected and cultivated in the same way the cultivations are made on the mainland. They proved to be a success but we had to wait for the results of forcing them in the States. Three years ago we received the first six cases in miscellaneous sizes of this stock and they turned out excellent. The year after, about sixty cases were consigned to us and again gave such satisfaction that we cabled to our Yokohama house to plant as many as possible. As a result we received over 300 cases last year and expect over 2,000 cases the coming season.

The Formosa lily flowers in the month of February on its native island or about two months earlier than the Bermuda lily. The bulbs are thoroughly ripened by the end of May, when shipments will commence which we count on reaching New York the end of July or the first part of August. The long rest the bulbs have until they can be potted will be decidedly in their favor.

The Formosa lilies should not be forced as hard as the Harrisii, otherwise they grow too tall. Nothing need be said about the quality of Formosa longiflorum bulbs, as they are recommended enough by the growers who have tried them.

Yours very truly,
THE YOKOHAMA NURSERY CO., LTD.

There are some
GOOD BARGAINS

listed in the
BUYERS' DIRECTORY,
 Pages 510 to 515, this week.

U. S. APPRAISERS' DECISION.

No. 18580, Bark Baskets.—Protest 267462 of Russin & Hanfling (New York). Opinion by McClelland, G. A. Bark Baskets, classified as manufacturers of grass, were claimed to be dutiable as unenumerated manufactured articles under section 6, tariff act of 1897. Protest sustained.

EASTER LILIES

"Yes! We've Got 'Em"

FINE STOCK

SEND ORDERS IN EARLY

SELECT \$15.00 per 100
 MEDIUM 12.50 " "

Write for prices on large quantities

MIAMI FLORAL CO.

DAYTON - - - - OHIO

Special Offer

Lilium Auratum, 11 to 13 in.
 \$4.00 per 100, \$35.00 per 1000

Double Begonia Bulbs

UNDER COLOR
 \$3.00 per 100, \$25.00 per 1000

V. H. HALLOCK & SON,
 QUEENS, NEW YORK

HYACINTHS, TULIPS, NARCISSI AND OTHER BULBS

ROMAN HYACINTHS and the true PAPER WHITE GRANDIFLORA

Ask for our Wholesale Trade List at Hillegom
K. VELTHUYS, Hillegom, Holland
 Rep. by **FELIX BOSCH, 260 Clarendon St., Boston.**

Gloire de Lorraine Begonia

2 1/4 inch pots, \$15.00 per 100
 \$140.00 per 1000

Thomas Roland
 Nahant - - Mass.

Orchids Orchids

WE WILL HAVE THIS SPRING LARGE IMPORTATIONS OF ORCHIDS FROM THEIR NATIVE COUNTRIES, BY OUR COLLECTORS. WE ALSO HAVE ON HAND A FINE LOT OF ESTABLISHED AND SEMI-ESTABLISHED ORCHID PLANTS, AND IF YOU ARE IN NEED OF ANY, DON'T FAIL TO GET OUR QUOTATION. OUR PRICES AND STOCK ARE OPEN FOR COMPETITION. GIVE US A CALL AND CONVINCE YOURSELF

JULIUS ROEHRS CO.,

Rutherford

= = = =

New Jersey

PREPARE FOR EASTER

And buy your plants from the old reliable Wholesale Grower of Easter Plants, Godfrey Aschmann, Philadelphia.

Easter Lilies, Lillum multiflorum, height, 15 to 40 inches, 6-in. pot plants above five buds, 10c. per bud; plants under five buds, 12c. per b'd.

Azalea Indica. Of this fine Easter plant we have an immense stock. Mme. Van der Cruyssen (best double pink), Niobe (double white), Deutsche Perle (double white), Simon Mardner (double pink), Apollo (red), Vervaeana (double rose variegated), Empress of India (double variegated, Prof. Wolters; Schryveriana (dark rose). Bernard Andrea alba, double white, of this variety only large plants, 1.00, 1.25, 1.50, 2.00 each; and many other sorts, price, 60c, 75c, 1.00, 1.25, 1.50 to 2.00 each.

Spiraea Gladstone, large plants only, full of buds and flowers, 6-in., 50c, 7-in., 75c, to 1.00 each.

Hydrangea Otaksa (pink), 6-7-in., 50c, 75c, 1.00 each.

Primula obconica, 5 1/4-in. 2.00, 2.50, 3.00 per doz.

Cineraria Hyb. best strain **Grandiflora**, 5, 5 1/2, 6-in. pots, 2.50, 3.00, 4.00, 5.00 per doz.

Hyacinths, dark blue, light blue, pink and white, 12.00 per 100.

Tounezel Tulips, best double Tulips, 3 bulbs in one pot, 1.50 per doz. pots.

Von Sion Daffodils, Best Yellow Double Narcissus, 5, 5 1/2, 6-in. pots, 3 bulbs in one pot, 2.00, 2.50, 3.00 per dozen pots.

Begonia new improved Erfordi, 4-in., 20c, 5 1/4-in. 25c.

Begonia Flambeau, good seller, 5 1/2-in. 25c, 4-in. 20c.

White Daisies, 5 1/4-in. 25c.

Kentia Belmoreana and Forsteriana, 4-in. 35c, 5 1/2 to 6-in., 50c, 60c, 75c.

Latania varbonica, 5 1/2-in. 35c.

Ficus Elastica or Rubber Plants, 5 1/2 to 6-in. pots, 40c, 50c.

Ipomoea Multiflora, best pure white Moon Vine, 2 1/2-in. pots, \$5.00 per 100.

Araucaria excels glauca, Specimen Plants, 6 and 7-in. pots, 6 yrs. old, 4-5 tiers, 25-40 inches high, 1.75, 2.00, 2.50, 3.00. Robusta compacta, 7-in., large plants, 30-40 inches, 2.50, 3.00. Excelsa, 4 yrs. old, 6-in. pots, 4-5-6 tiers, 20-30 inches high, 75c, 1.00, 1.25 each; 5 1/4-in. 50c.

Please mention if plants are to be shipped in or out of pots. Cash with order please. All goods must travel at purchaser's risk. No lilies sold by themselves, other plants must accompany the order.

GODFREY ASCHMANN,

1012 West Ontario St., Philadelphia, Pa.

Importer, Wholesale Grower and Shipper of Pot Plants.

ORCHIDS

We are at present booking orders for freshly imported Orchids for delivery 1908, of all leading kinds at reduced prices. We have just received the following:—**Oncidium Sarcodes, O Forbesii, O. Tigrinum and Sophronites, Grandiflora and Coccinea.**

LAGER & HURRELL, Summit, N. J.

ORCHIDS

Largest Importers, Exporters, Growers and Hybridists in the World

Sander, St. Albans, England and 235 Broadway, Room 1 NEW YORK CITY

ORCHIDS

We shall receive in about two weeks' time fine importation of **Dendrobium Wardianum, D. Phalaenopsis, D. Formosum giganteum.**

April: Most all the **Cattleyas, Vandas, Oncidiums, etc.** Write for Price List.

GARRILLO & BALDWIN, Secaucus, N. J.

ORCHIDS

The largest importation of Orchids ever received in this country **WILL ARRIVE** next spring from Brazil, Colombia and Venezuela. If you intend putting in stock wait for these to arrive and we will quote the **Lowest Prices in America.**

ORDONEZ BROS., - Madison, N. J.

ORCHIDS for Spring Delivery

NEW IMPORTATIONS

Cattleyas, Laelias, Oncidiums, etc.

WRITE FOR PRICES

Now is the time to Pot Orchids. Best Quality of Peat, Moss and Baskets on hand.

JOSEPH A. MANDA, 181 Valley Road, WEST ORANGE N. J.

FERNS

Boston, 4 inch 12c, 5 inch 25c.

Pierstonii, 3 inch 8c.

Eleganti-sima, 2 1/4 inch 6c, 3 inch 10c, 4 inch, 15c.

BAUR FLORAL CO., Erie, Pa.

NEPHROLEPIS SCOTTII

in the following sizes, extra good value

25c., 50c., 75c., and \$1

Grand Specimen Plants at \$3, \$4, \$5, \$6.

JOHN SCOTT

Rutland Road and E. 45th St.

Tel. 2890 Bedford **BROOKLYN, N. Y.**

NEP. WHITMANI

2 1/4 in., \$5.00 per 100

NEP. WHITMANI

3 1/2 in., \$25.00 per 100

BOSTON FERNS

2 1/4 in., \$3.00 per 100

H. H. BARROWS & SON Whitman, Mass.

COLD STORAGE

MULTIFLORUM LILY BULBS

7 to 9s

Delivery Immediate or as Ordered. \$45 per 1000

WOOD MOSS, 65c per b'dle.

O. RUSCONI, 128 W. 6th Street, Cincinnati, O.

JAPANESE

THE YOKOHAMA NURSERY CO.
31 BARCLAY STR. NEW YORK.

LILIES
PLANTS
BAMBOO STAKES

M^CMANUS

Known all over the Choice Flowers



As heretofore I
Easter Need.
Order Early. Ca
deræ in Man
Beautiful Var
in Season.
have ever been s
leyas in splen
Dendrobiums
and Nobile,
Phalænopse
ums, Cœlogy
diums.

I make a specialty of assorted lots. Try an adva

Also Finest Gardenias, Daisies, Lily of t

JAMES M

Wholesale Dealer in Fancy Business-Bringing Flow

Telephone, 759

ORCHIDS

Continent where are Appreciated

an supply the
of those who
tleya Schro-
Chaste and
eties is Just
o finer flowers
n. Other Catt-
d assortment.
Vardianum
Oncidiums,
Cymbidi-
es, Cypripe-



ee shipment and let your customers see them
e Valley, and all Regular Easter Stock

McMANUS

s.

42 West 28th Street, NEW YORK

Madison Square



EASTER SHIPMENTS

Now is the proper time to place your order for Lilies, Roses, Carnations, Sweet Peas and other stock required for the Easter demand. We are ready to quote prices and your order given now will be filled properly and on time.

LONGIFLORUM LILIES

in pots or cut, carefully packed at greenhouses, \$12.50 per hundred flowers. THESE ARE FIRST QUALITY LILIES.

OUR SUPPLY OF

BEAUTY, RICHMOND, KILLARNEY, BRIDE and 'MAID and CARNATIONS in Leading Sorts

has never been excelled and prices are very reasonable.

Folding Boxes, Baskets, Wire Designs, All Green Material and Other Supplies at Lowest Wholesale Rates.

WELCH BROTHERS

Tel. Main 6267

226 DEVONSHIRE ST., BOSTON, MASS.

POT ROSES FOR EASTER.

Written for the American Rose Society by Robt. Craig.

It was thought by the officers of the Rose Society that some notes on this subject would prove useful to beginners in the business, and in accordance with that idea, I give the results of my observation and experience. The principal obstacle in the way of having fine specimen roses at Easter, lies in the difficulty of obtaining sufficiently strong plants; in roses of the Crimson Rambler and Wichuraiana types, strong canes can be had by planting out in the open ground in heavy soil, well manured and leaving the plants out at least one winter; when they are left out for two winters they make extra strong plants, with long, strong canes suitable for training into large specimens. Magna Charta, which is undoubtedly the best of all the Hybrid roses as an Easter pot plant, may be treated in like manner; this also applies to Clothilde Soupert, which is deserving of special mention on account of its freedom of bloom, distinct color and above all, its good keeping qualities; it may be kept, in a cool house, for two weeks in full bloom, which cannot be said of many of the varieties. Among other good Easter Hybrids for pots (I know of but few) may be mentioned Mrs. John Laing; Ulrich Brunner (of fine color but a poor keeper), Rodocanachi, Mlle. Gabriel Luizet, Gen. Jacqueminot and Killarney; if sufficiently strong canes of the latter can be had it is one of the most attractive—but these varieties do not make strong plants on their own roots in the open

ground, especially in the northern states.

Handling Imported Stock.

For such varieties as cannot be obtained from nurserymen in this country, recourse must be had to importing the strongest plants possible from Europe in the fall, preferably from England or Ireland, budded low on manetti. Those from Holland are generally budded too high on the stock to make attractive pot plants. Plants which are packed for shipment should have their roots surrounded by damp moss, and should be exposed to the air as little as possible from time of lifting until they are potted; many failures result from lack of this precaution. The plants should not be lifted until they have had some frost to thoroughly ripen the wood; in the latitude of Philadelphia this is usually from the middle to the latter part of November. I have never been able to get however, plants uniformly strong enough to force them the first season after importing; the plants are not graded into sizes and many sent are too small to make suitable plants the first season after importing. It is our custom to take only the stronger plants and the others are wintered over, as cheaply as possible in cold frames or houses, to be grown in pots the following summer, which treatment greatly benefits them. The Crimson Rambler, if carefully handled, will make fine plants the first season from open ground, but the other varieties will bloom more freely if grown in pots one season. The cost of wintering imported plants

in frames is about \$50 per thousand, and the cost of growing them through the summer about \$50 per thousand additional, but the improvement in the character of the plants fully justifies the expense for Easter purposes. Air should be given during the winter whenever the weather is mild enough, and every precaution taken to prevent the tops from growing as long as possible; after the young roots have started they should not be allowed to freeze, as they are thus easily killed; the pots should stand on a dry bottom and be packed in leaves, sawdust, ashes or other suitable material.

The Ramblers.

The Crimson Rambler has been for many years a very popular Easter plant, but its popularity is waning; it will still be grown, but in smaller quantities than formerly, but fortunately there are a number of climbers that may be grown profitably, and which have the charm of novelty. Among the very best are Lady Gay, Dorothy Perkins, Tausendschon and Hiawatha; the last named is especially charming; although the bloom looks frail, it is a fine keeper, and I look for it to increase in popularity. The new variety, Newport Fairy, will undoubtedly be largely grown when its merits become known. Another very fine one is Mr. Walsh's Juniata, and no doubt there are other hybrids in the Wichuraiana section which I have not had the opportunity of seeing.

Culture of Pot Roses.

The culture of pot roses for Easter is very simple, but there are certain

Phil. F. Kessler

55 and 57 W. 26 Street
NEW YORK CITY

Offers the Finest Stock of

LONG STEMMED **LILIES**

CALLAS AND OTHER

Easter Flowers

At Wholesale Flower Market Prices

Write for Quotations

GARDENIAS

No Finer Blooms in Market

American Beauty Lilies

LARGE SUPPLY OF BOTH

Cottage Gardens Carnations

BEST IN THE WORLD

Order Now Your Supply for Easter

JOHN YOUNG

51 W. 28th St., **NEW YORK**

rules, as to temperature, airing, and the prevention or destruction of insects, which must be faithfully followed. The soil should be a clay loam enriched with well decomposed stable manure, and I like to add a liberal sprinkling of bone dust and fine sheep manure, the latter gives the foliage a rich dark color. The plants should be carefully and very firmly potted, using a potting stick to pack the soil about the roots. It is well to shade the house either with slats or by whitewashing the glass with whiting and coal oil, and sprinkle frequently with water to keep the wood plump until the young roots start; they should never be allowed to shrivel. Keep for five or six weeks in a night temperature of 40 to 45 degrees; the plants should by this time be well rooted and the temperature may be gradually increased, if necessary, to 60 or 65 degrees at night. When we have a late Easter, as this year, it may be at no time necessary to exceed 60 degrees; the lower the temperature at which they can be flowered in time, the better. Crimson Rambler and Wichuriana roses may be trained in various shapes, globular, oval, or in the form of fans, etc., or they may be cut back to about one foot from the pots and grown without any staking. In these severely cut back plants the clusters of flowers will be larger than where more of the wood is retained and the lighter branches allowed to bloom. Use tobacco stems between the pots to keep down insects, cleaning out and removing about once a month. Give always plenty of air if weather permits; if this is regularly attended to,

mildew is not likely to appear, and when the buds are set an occasional watering, say once in two weeks, with manure water is beneficial. Soot water is also excellent to improve the foliage and color of blooms and serves also to destroy worms.

To recapitulate, I should say the principal points to be observed are: Lift carefully, pot promptly and firmly, start at low temperature, always as much air as possible, use tobacco stems between the pots which should have some space between them from the very start.

PICKED UP BY WIRELESS.

Poehlmann Bros. will discontinue growing Perle and Sunrise roses and give the space to asparagus and Croweanum fern for the Chicago market. Peter Crowe says that outside of his own place he has never seen Croweanum so well done as at Poehlmann's. Poehlmanns will not build that proposed large addition this year, but will wait for more settled "times" and the glass market has thus got a big set-back. With a payroll of \$7,000 a month not including store salaries, with 500,000 chrysanthemums in the cutting bed, 236,000 young carnations potted up and five acres of carnation benches under one ridge-and-furrow roof there'll still be "something doing," however, at Poehlmann's, and John Evans' Challenge ventilator, new pattern, is preferred to all others. Speaking of Adiantum Croweanum, Peter Crowe says it will stand all the heat you can give it, and he's the man

who ought to know. "Connected houses opening together are all right for teas," says Mr. Poehlmann, "but the best for Beauty is the separate house, not over 20 ft. wide." If you want reasons, he can supply them.

At this point the receiver picked up a message from E. G. Hill who, by the way, is generally talking about roses except when he is asleep or is persuading you to buy something. Mr. Hill was calling attention to his new pink seedling rose, a cross between Beauty and another seedling which is destined to make a sensation equal to Richmond. The pink Testout seedling to which the name of Princess was first given is waiting for another name, "Princess" being already in use. Mr. Hill has a full bench of it. Among the new rose importations Laurent Carle, one of Pernet Bucher's introductions, is regarded as a fine bedding rose by Mr. Hill. It bears a large flower similar in color to Rhea Rebel. Lady Fair is a promising free-blooming La France-colored rose from England. The new English "Baby Rambler," Phyllis, is pronounced by Mr. Hill to be the best yet. It is glowing pink in color, and blooms abundantly. Another handsome garden rose is Konigen Carola, color Wellesley pink. Watch out for some sensational surprises in seedling carnations from Hill's shortly. He has them. If you don't believe it you can go and see and you'll doubt no more. And—

Hello!—here communication is interrupted by no less a person than Ed. George, who wields authority over

LILIES FOR YOU

**The Same High Grade for Easter that we
Have Been Furnishing in Years Past**

Packed in Boxes of Twenty-five Pots each, nicely Crated over the Top. Our Packing is undoubtedly the BEST IN THE UNITED STATES.

Prices in Case Lots, 12 1-2c. per Flower. Five or more cases 12c. per Flower. Ten or more cases 11c. per Flower. Order Early so that we may be able to Ship them Direct from the Greenhouses.

And Don't Forget

that we carry a full line of fresh flowers, all varieties, and the largest stock of Florists' Supplies in New England.

N. F. McCARTHY & CO.

Wholesale Florists.

84 Hawley St., BOSTON

the greenhouse department of Storrs & Harrison Company at Painesville, Ohio. A long jump from Richmond out the "wireless" is no regard of mileage. Mr. George says that Dreeer's variegated-foliaged Bougainvillea "W. K. Harris" is finding great favor with the florist trade by reason of its fine decorative effect when worked in among green foliaged plants. (Following apparently on the same lines with its illustrious namesake.) Mr. George imparts the pleasing news that palms, after an extended dull period, have been enjoying a nice active demand during the last few weeks. He has nothing but words of praise for Baby Dorothy rose, which he regards as a ranking companion to Baby Rambler, but sees no future for Amny Miller, which is "simply awful" for mildew.

The "begonia mite," that troublesome insect microscopic in size but prodigious in destructiveness, has been doing lots of mischief among the Rex begonias at Storrs & Harrison's, but the remedy seems to have been found in placing the plants in the palm house and giving them an abundance of moisture. Among the bedding plants worthy of more general use are the Acalyphas Miltoniana and bicolor compacta, the latter being the newer one and characterized by more lance-like foliage with variegation of clear-white and more drooping habit. Mr. George says that Verschaffeltii, Golden Bedder and Beckwith Gem are still far away beyond the demand for all the other colenuses and although old, retain their leadership over every type of newcomer.

A NEW FACTOR IN THE PLANT TRADE.

The new enterprise of the Fruit Auction Company in New York city whereby they inaugurate a series of daily plant trade sales throughout the season, conducted on lines similar to the wholesale fruit sales, brings to view many possibilities of paramount significance to the plant trade and which may mean, eventually, almost a revolution in the methods of marketing horticultural products. The innovation will be watched with eager interest by the trade and the effect of the establishing of this new and comprehensive outlet for the plant products carefully noted. That, with enhanced facilities for distribution, the magnitude of the plant sales of New York could be many times multiplied, requires no proving to those who know how far short our American cities fall in plant consumption as compared with European cities. The methods which have so enormously developed the fruit trade of the metropolis stand well to exert a similar influence on the plant trade. The superb equipment of the Fruit Auction Company's building, their great financial strength and the resourceful qualifications of John P. Cleary for taking charge of this particular department, are a guarantee that the new scheme will be well tried out.

CLUB AND SOCIETY NOTES.

A delegation from the Worcester Market Gardeners' Association visited Fitchburg, Mass., on March 28 and spent a most profitable day inspecting the greenhouses of James Heslam and

William Proctor. Cucumbers in all stages of development were seen. A collation was served at noon by Mr. Heslam.

Chicago Florists' Club meets the third Thursday of each month. Out of town visitors are always welcome. Four new members were added to the club at the last meeting.

The April exhibition of the Worcester County Horticultural Society was held on the 1st inst. Every class called for was represented. H. F. A. Lange, E. W. Breed and A. E. Hartshorn were the principal prize winners.

The Houghton Horticultural Society, Lynn, Mass., at their recent business meeting, decided to offer better prizes for competition at the fall show. Plans for summer outings were also completed.

The Twin City Florists' and Gardeners' Club has sent out cards bearing the wholesale and retail prices respectively of the various spring bedding plants in which the members are interested, the prices having been adopted as a standard by the club at a meeting on February 18.

At a meeting in New York on Saturday, April 4, the committee on organization of the proposed new orchid society recommended that further activity in organization be deferred for the present, and that those interested accept the suggestion of the New York Horticultural Society to associate themselves with that society and act as a special orchid committee, it being understood that at a later date the movement for an independent society would probably be resumed.

HERE THEY ARE AGAIN

Our Usual High Quality

**LILIES, ROSES,
CARNATIONS,
FOR
EASTER**

**VIOLETS IN BLOOM
IN POTS**

Great Sellers. Try Them

FORD BROS.

48 W. 28 Street, NEW YORK
Tel. 3870-3871 Mad. Sq.

Red Letter Sale For EASTER

**Roses and Carnations,
In All Standard Varieties**

**Lilies, Bulbous Flowers,
Etc.**

**Get Busy on the Wire and
Make Your Wants Known Early**

PRICES LOW

H. E. FROMENT

57 West 28th St., New York

TEL. 2200, 2201, Mad. Sq.

THE ROSE FROM A RETAILER'S VIEW AND THE PART THAT THE ROSE PLAYS IN DECORATIONS.

(A paper by J. F. Sullivan, before the American Rose Society.)

In attempting to treat this very broad subject many phases of it appear for the consideration of the essayist and the introduction of anything that is really novel seems most difficult, but if the mere recital of that which is well known, and the awakening of increased interest in the subject is, as I believe, valuable, the paper may be entitled to a place in the report of the proceedings of this society. It will be observed that the question is viewed from the position of a retailer of cut roses chiefly.

The Pioneers.

The present great extent of the rose trade was developed by many contributing factors, but I believe the chief of these were the pioneer retail florists, who in their time were the first to realize the commercial possibilities of the Queen of Flowers. To these men is due the honor of having appreciated the full worth of the rose and laid the foundation of its illustrious career. They loved the Rose and had faith in its future and no unfavorable circumstances deterred them in advancing the prestige of their adopted flower, nor from courageously asking a price for it commensurate with its actual value as determined by the cost of production. Many of these pioneers have passed away but their work is perpetuated, and

their monuments are seen in the present magnitude of the rose industry. These enterprising far seeing retailers in the early days of their experience were quick to perceive the manifest delight and approval of their discerning customers on being shown a rose of more than ordinary size and beauty, and thus encouraged, they in turn urged the growers on to increased efforts, and the latter stimulated more by the prospective reward than the love of their productions continued to improve the existing varieties of roses, and by the repetition of these progressive steps in the Eastern cities, chiefly Boston, there was created the substantial beginning of the evolution of the rose in this country, which has continued to the present day. Those were the days when reigned old Safrano, Isabella Sprunt, Bon Silene, Cornelia Cook as forcing varieties, and the annually forced crops of Gen. Jacqu, Anna d' Diesbach, Baroness Rothschild, Merveille d' Lyon and a few other hybrids.

The Rose the Chief Asset.

And here is suggested the inquiry, why have the retailers in the early days of floriculture and continuing to the present time selected the rose as the basic element in their business careers? Why have they continued to maintain the rose most conspicuously before their trade? Why are so many florists today, while not ignoring the increasing value of many other branches of the business making roses a specialty and succeeding in their efforts to permanently popularize them? Because the retailers wisely

view the rose as their chief asset in merchandising. Without it their place would be devoid of the essential attractiveness and proper equipment of a floral store. As an article of merchandise or practically considering it, the florists realize that in no other stock of cut flowers can they operate with the same degree of immunity from possible loss that the rose gives them; they can as every florist well knows stock up with a supply of tight cut buds, which being at once salable, continue to actually improve on their hands for several days, more or less according to the season and varieties, before they begin to decline, and even then, they are just about in the right condition for that funeral design for which he wisely suggests them. For shipping long distances no flower is more suitable or certain of satisfactory results viewed alone upon its splendid keeping qualities. Retailers of the seaboard cities use roses almost exclusively in their so called "steamer trade."

I am reminded of the case of some blooms of the Richmond rose, being shown at a meeting of the Detroit Florist Club three years ago. The same flowers after being kept in a refrigerator were shown at the exhibition of the American Carnation Society in Chicago eight days later. When the question of the dealer's supply is considered, the rose can be shipped to him if necessary by his grower situated far away, and the availability of the rose in all seasons adds great value to his chief commodity in stock.

JOHN I. RAYNOR

— OFFERS —

A Complete Assortment of Top Grade Roses,
Carnations, Lily of the Valley, Daffodils, Violets,
Callas and

EASTER LILIES

This supply comes, as it has for many years, from the largest and best growing establishments for New York market. Can fill order, any quantity, at wholesale market rates.

— WRITE OR TELEGRAPH —

49 West 28th St., New York

Telephone — 1998 Madison Square

Always Appropriate.

On no occasion of the many where flowers of some kind are used is the rose ever considered unsuitable or inappropriate. The retailer fully appreciates the appropriate character of the rose for all purposes of decorative effect and its unequalled position without a worthy rival in the affections of the greatest portion of humanity. The florist can in all sincerity suggest the rose as the friendly gift, the christening of either the baby or the vessel, and for the hand of the bride it is most essential. We can select it as the message to the sick room and with equal propriety use it as a mark of condolence and respect to the dead.

Indeed were the rose eliminated completely from the mountain of retail floriculture the cavity would be so great it would be difficult to properly identify it. These and many more that may be named, are the reasons why the retailers look upon roses as being the most reliable, valuable and indispensable article of their merchandise.

Keeping pace with the evolution of the rose in the various degrees of its advancement, came the improved methods in decorations, and here too, the Queen of Flowers plays a most conspicuous part. In the richness of its individual beauty, clothed alone by its own rich foliage, it enables the decorator to carry out, better than with any other flower, the idea of a modest, charming simplicity in decorative effect, with the most satisfactory results. How frequently we are asked to adorn a person, a picture, a mantle

or other object with "just one rose" so exquisite and impressive in its simplicity.

The Rose in Elaborate Decorations.

In depicting the part the rose plays in elaborate decorations, we may say the world cheerfully concedes the tribute this flower alone deserves above all others, it being the very essence of decorative effect in whatever manner it is shown. The individual flower, the vase of them, the bank of roses, or baskets of the same; and it is doubtful indeed if there can be found in any part of the country, a retailer whose establishment lays claim to being first class in its appointments, that does not give roses pre-eminence of importance in his store as a result of the recognition of their value fundamentally, in decorative effects.

And this is not surprising when he considers the distinctive beauty and striking grandeur of the rose itself stripped of all sentimental significance attached to it from ages past down to the present time. Standing alone in its purely decorative character it challenges the unvarying admiration of all who behold it. Ofttimes this admiration and devotion approaches the highest degree the heart is capable of.

Any one of the many beautiful varieties, without the accompaniment of other flowers or floral accessories is equal to any occasion, when the perfection of floral beauty and magnificent splendor is desired. Other flowers may in their respective seasons find a measure of favor, usefulness, and even popularity with

the lovers of the beautiful in nature, and in decorations you may mix them in an incongruous mass without doing great violence to their individual character, but the rose alone cries out pleadingly for a position of isolation where unaided by associates, ribbons, ferns or other accessories, the rare, unrivalled splendor and magnificence of its decorative effect, is most pleasing and appreciable.

Its Sentimental Value.

But it is not alone the practicability of the rose, it being the corner stone of the business edifice, that makes it interesting to the retailer. He with the whole civilized world recognizes the perfection of its natural beauty and the inexpressible thrill of joy experienced by those who behold it in its magnificent and unequalled splendor. The florist presenting the rose—fair, fragrant and exquisite, offers no apology when advancing its fame as the "Queen of Flowers," always encouraged and confident that no flower grows that can excel the rose, and where an occasion is presented when it is desired to express purity of life, a stainless character, unquestioned integrity, and virtuous career, we turn instinctively to the emblematical flower—the pure white rose. The rose is beautiful even in its dainty promising bud, the half or full open flower. Indeed the great artists often select the latter as subjects for their finest work, and not infrequently do we see some varieties in the very last stages of their development and even bordering upon decay, yet embodying the very perfection of floral beauty.

(To be Continued.)

TRAENDLY & SCHENCK,

WHOLESALE
FLORISTS

'PHONE, 798-799 MADISON

44 West 28th Street

NEW YORK CITY

All the Novelties in high class ROSES.

All the Novelties in high class CARNATIONS.

We will have about 3000 CATTLEYS FOR
EASTER.

SWEET PEAS in quantities, also VIOLETS IN
ANY QUANTITY.

And all other Seasonable Flowers.

Orders by Mail, 'Phone or Telegraph promptly attended to. Price List on application.

PERSONAL.

E. R. Chappell of Chicago has taken a position with Clarke Bros., Portland, Ore.

Visitors in Boston: Paul Berkowitz, Philadelphia; Robert Kift, Philadelphia; Wm. Appleton, Providence, R. I.

Visitors in Boston: Donald McLeod, Concord, N. H.; E. J. Harmon, Portland, Me.; Conrad Schultz, Westerly, R. I.

W. H. Witte has received the appointment of gardener at Wyman park, Johns Hopkins University, Baltimore, Md.

Austin Wallace has left Kokomo, Ind., for El Paso, Ill., where he will take charge of the El Paso Carnation Company's houses.

Frank Good will manage the flower department this summer at the Marlborough-Blenheim, Atlantic City, for S. Hofmeier of New York City.

Visitors in Chicago: Jno. and Mrs. J. Soper of Rockford, Ill., are in Chicago looking for material for building new office and salesroom. George F. Crabb, Grand Rapids, Mich.

Hugo Richter formerly traveller for Otto Beyrodt, Marienfeldt, will hereafter represent Messrs. Sander & Sons, St. Albans and Bruges, in the German Empire, Hungary and Russia.

John Cleary, father of John P. and Ambrose Cleary, both well known in the plant auction trade of New York city, lies at the point of death at his

home in Haverstraw. Old age is the cause.

Thomas Foulds, who for the past two years has been gardener for the Home Culture Clubs, Northampton, Mass., has resigned his position and will take charge of the estate of E. P. Leonard at Amherst, Mass.

NEWS NOTES.

L. Whinery has opened a greenhouse at Winona, O.

John Lamont has started in the greenhouse business at So. Hadley Falls, Mass.

Franklin & Crosby open their new greenhouse on Academy street, Danielson, Conn., on April 11.

It is stated that the Home Culture clubs of Northampton, Mass., will abandon the scheme of running a greenhouse and flower store.

Jacob Dietrich of Los Angeles has been appointed general agent for Southern California of the Yokohama Nursery Co., Yokohama and New York.

Robert B. Graves, the well-known florist of Northampton, Mass., celebrated his eighty-eighth birthday on April 2. Mr. Graves is vigorous and actively interested in his work.

Krueger Bros., florists, of Toledo, O., have recently purchased twenty-six acres on Woodville road, which will give them the opportunity to nearly double their present capacity.

Speaking of the use of grafted forcing roses, W. H. Elliott says that he grows his roses in thin soil, scarcely

of his best roses have been grown in deep enough to cover the union. Some not over three inches depth of soil.

Board of Park Commissioners, City of Minneapolis, Minn., 25th Annual Report, 1907. A beautiful volume, finely illustrated and full of interesting facts concerning this rapidly developing metropolitan park system under the able management of Theodore Wirth as superintendent.

The city of Nashua, N. H., has received a gift of \$5,000 from John E. Cotton on condition that the city government expend a similar amount within the space of two years for the improvement of Greeley Farm Park. The gift has been accepted and the city's appropriation has been made.

Mr. Geo. A. Parker, superintendent of Keney Park, Hartford, Conn., says of the Peetron Improved Levels, advertised in HORTICULTURE:

"Having purchased your Level last season, it gives me pleasure to say that for an accurate, low-priced instrument, so simple in its construction that a man without a technical training can use it successfully I know of no better Level than yours."

The Advance Co. of Richmond, Ind., are placing on the market a new coupling for shafting pipe in greenhouses and have made application for a patent on same. This is a neat, strong device for coupling up the shafting pipe by the aid of a monkey wrench only and holding same firmly in place, thus doing away with the disagreeable and hard work of screwing the line shaft together by the use of pipe wrenches up under the glass.

LILIES

I Have Them! The Best on the Market

ALSO

**HEATHER, AZALEAS, HYDRANGEAS,
GENISTAS, DAISIES, POT ROSES, Etc.**

SAMUEL A. WOODROW

WHOLESALE PLANTSMAN

53 West 30th St., TEL. 2083 MAD. NEW YORK CITY

PROMPT DELIVERY AND SATISFACTION GUARANTEED

Easter Lilies \$12.50 per 100 **Superb Lily of the Valley** \$4 per 100

American Beauties, Richmonds, Killarneys, Brides and Bridesmaids

Violets, Carnations, Daffodils, Tulips, Narcissus, Hyacinths, Sweet Peas, and all seasonal flowers. For Easter decorations: Southern Wild Smilax, Laurel Festooning, Leucothoe Sprays, Hardy Cut Dagger and Fancy Ferns, Bronze and Green Galax.

ALL ORDERS RECEIVE PROMPT AND PERSONAL ATTENTION

HENRY M. ROBINSON & CO.

Telephones
2 17-2618 Main

Wholesale Commission Florists

15 Province St., 9 Chapman Pl.,

BOSTON, MASS.

PLANT IMPORTS.

There were entered at the port of New York during the week of April 1 to April 7 inclusive, the following goods:

Via Rotterdam: Amerman & Patterson, 14 cs. plants; C. C. Abel & Co., 36 cs. bulbs; H. F. Darrow, 154 cs. plants; Wm. Elliott & Son, 20 cs. do.; McHutchison & Co., 34 cs. do., 3 pgs. do.; Maltus & Ware, 112 cs. do., 45 cs. trees, 6 tubs do.; P. Ouwerkerk, 95 cs. do.; C. B. Richard & Co., 55 cs. do., 178 cs. plants; J. Roehrs & Co., 11 cs. trees, 25 cs. trees and shrubs; Vaughan's Seed Store, 24 cs. plants; Wadley & Smythe, 25 cs. do.; Forwarders, 2 cs. do., 7 cs. trees.

Via Antwerp: Maltus & Ware, 10 cs. plants; Wadley & Smythe, 4 cs.

do.; Sundry forwarders, 3 cs. do., 2 tubs laurel trees.

Via Southampton: Amerman & Patterson, 19 cs. plants, etc.; H. F. Darrow, 10 pgs. seeds and plants; McHutchison & Co., 2 cs. plants; Maltus & Ware, 4 cs. do.; C. B. Richard & Co., 6 cs. do.; Rochester Park Commissioners, 6 cs. do.; Sundry forwarders, 20 cs. do., 1 cs. trees.

Via Liverpool: Wadley & Smythe, 6 cs. trees.

From London: Funch, Edye & Co., 1 crate trees.

Via Havre: J. P. Roosa, 1 cs. do.; Chas. D. Stone & Co., 12 pgs. plants. From Germany: Forwarders, 2 cs. plants.

Elliott's "Good Friday" auction sale promises to be a corker. See his advertisement.

Cut Flowers

We will have a large supply of all Cut Flowers for Easter. Send your order to us, we will ship you the "kind of flowers you want when you want them."

SUPPLIES

We have a large stock of all novelties, etc., just what you want for Easter.

Write for our handsome Easter price list
NOW READY

E. F. Winterson Co.
45-47-49 Wabash Ave., Chicago, Ill.

Look at List of
NEW OFFERS

Pages 514-515

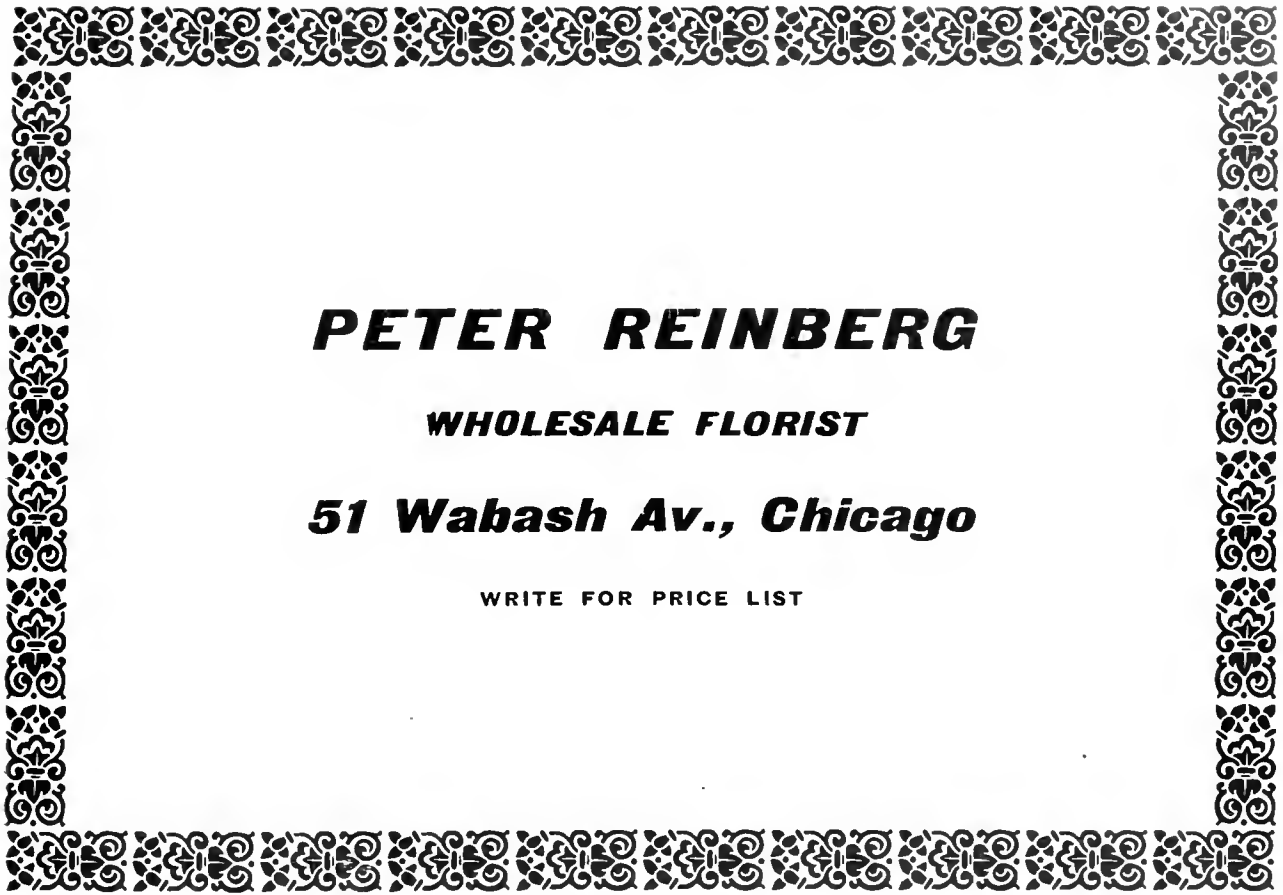

PETER REINBERG

WHOLESALE FLORIST

51 Wabash Av., Chicago

WRITE FOR PRICE LIST

Edward C. Horan

55 WEST 28th ST. - NEW YORK

Cut
Flowers
at
Wholesale

WRITE FOR EASTER PRICE LIST

TELEPHONES 1462 1463 MADISON SQUARE

Keep Up Courage
and Be Game
Better Times
Are Coming

ALWAYS AT YOUR SERVICE

Yours very truly,

Alexander J. Suttman
THE WHOLESALE
FLORIST OF NEW YORK

43 WEST 28th STREET

Telephone 1664-1165 Madison Square

SEND EASTER ORDERS
NOW.

OF INTEREST TO RETAIL FLORISTS

SIMPLICITY AND HARMONY.



Our illustration shows a view in Strassburg's Hall, Detroit, as decorated for a debutante reception by John Breitmeyer's Sons early in the winter. Wild smilax and poinsettias were the principal materials used. We

introduce it particularly as an object lesson in simplicity and harmonious effect. It is exquisitely done and is, we think, worthy of a little study. In the majority of cases where florists are entrusted with such work it is very apt to be overdone.

Easter Suggestions

We all know only too well that during such strenuous times as Easter brings to us cut flowers can not be handled as carefully as during normal times. Even the best blooms will suffer by overcrowding in the ice box and the contact with buyer and seller, still we shall be compelled to ask a higher price for them than usual.

Therein lies a great pointer for the wholesaler whose future prosperity depends as much on the satisfaction the retailer's customer receives from the wares purchased in the store as does that of the retailer himself. The wholesaler knows full well what trials the retailer must encounter during such times and while the latter is perhaps willing to submit to the dictates of the wholesaler in the most important point of all—that is, the advance in prices—he only asks for one favor of him.

This one favor so important and yet so simple is somehow or other only reluctantly acceded to, although it has been practically the only stone in the path of prosperity for many wholesalers and more retailers who are one might be forced to say, entirely at the mercy of the wholesalers for their supply. This point so grudgingly granted is the supply of strictly fresh flowers. Everyone knows that it takes the cut of several days to supply the demand of one day, but several days is not a week. Give the retailer a chance to sell good flowers that will stand a little rough handling, so the customer may have something to en-

joy on the most important day of the year.

More co-operation is needed to solve the price problem so it may appear more reasonable to the public. Nobody will complain of a rise in prices around the holidays if within reason, but as long as we allow carnations to be sold at 15c. per dozen one day and the same goods are sold at \$1.00 to \$1.50 per dozen three days later, with a similar rise in all other flowers, the public is right in condemning our business methods.

It may be well for the wholesale house to try and clean up daily to faki's instead of sacrificing many thousands of flowers, but it is doubtful whether the net result increases the grower's profits. Certain it is, though, that in the eye of the public we are losing heavily, and the public after all is our legitimate judge.

Although far from wishing to advocate trust methods it seems proper to suggest to the grower that it would be cheaper for him to curtail his shipments several weeks in advance of the holidays and suffer the loss at home instead of through his city outlet. His product instead of bringing barely enough to pay express charges would bring him a fair return, while the retailer could then sell at a healthy figure, not fearing competition he simply cannot meet.

The public understand well enough that the holidays bring about an advance in everything and do not object to a reasonable one, but a jump from

JOHN BREITMEYER'S
SONSCor. Miami and Gratiot Aves.
DETROIT, MICH.Artistic Designs . . .
High Grade Cut BloomsWe cover all Michigan points and good
sections of Ohio, Indiana and CanadaWilliam J. Smyth
FLORIST

Cor. Michigan Ave. and 31st St., CHICAGO

We ship to all points in Illinois and Iowa.

Phones: Douglas 744, Douglas 523, Douglas 740

M. C. and J. E. HAUSWIRTH

232 Michigan Ave.

CHICAGO

AUDITORIUM ANNEX

Tel. Harrison 585

SAMUEL MURRAY

Florist

Coates House Conservatory
1017 BROADWAY, KANSAS CITY, MO

Both 'Phones 2670 Main

FRED C. WEBER
FLORIST4326-28 ST. LOUIS, MO.
OLIVE STREETEstablished 1873
Long Distance Phone Bell Lindell 676WASHINGTON,
D. C.

GUDE'S

Geo. H. Cooke
FLORISTConnecticut Avenue and L Street
WASHINGTON, D. C.

The Park Floral Co.

J. A. VALENTINE
Pres.

DENVER, COLORADO

WILLIAM L. ROCK
FLOWER CO.

KANSAS CITY, - MO.

will carefully execute orders for Kansas City
and any town in Missouri or Kansas.

Florists Out of Town

Taking orders for delivery in **New York or Vicinity** can have them filled in best manner and specially delivered by

Thomas Young, Jr.

500 F. 5th Ave., New York City
Telephone 847 Bryant.

ALEX. McCONNELL
571 FIFTH AVENUE
NEW YORK CITY

Telegraphic orders forwarded to any part of the United States, Canada, and all principal cities of Europe. Orders transferred or intrusted by the trade to our selection for delivery on steamships or elsewhere receive special attention.

Telephone Calls, 487 and 488 38th St.
Cable Address, ALEXCONNELL

WILLIAM H. DONOHOE
FLORAL DECORATOR
17 East 28th St., New York
Special Attention to Theatre and Steamer Orders, and reliable deliveries guaranteed.

DAVID CLARKE'S SONS
Deliver orders from any part of the country to
New York City
Or OUT-GOING STEAMERS
Write or telegraph
2139-2141 Broadway, New York
Telephone 1552-1553 Columbus

M. A. BOWE
In the Heart of New York City
1294 Broadway
Tel. 2270, 38th St NEW YORK
Our Motto -- The Golden Rule.

YOUNG & NUGENT
42 West 28 St., NEW YORK
"FLOWERS BY TELEGRAPH"

Flower Deliveries
In Brooklyn and other Long Island Points New York City, New Jersey, etc. At Theatres, Hotels, Steamers or Residences.

WILSON
Fulton St. and Greene Ave., Brooklyn, N. Y.
ALBANY, N. Y.

EYRES
Flowers or Design Work
DELIVERED IN ALBANY AND VICINITY ON TELEGRAPHIC ORDER.
11 NORTH PEARL ST., ALBANY, N. Y.

JACOB SCHULZ, 644 Fourth Ave., LOUISVILLE, KY.
Cut Flowers of BEST QUALITY in season delivered promptly to any address.
Write, Telegraph or Telephone.
Cumberland and Home Phones 223 and 984

15c. per dozen to \$1.50 or \$2.00 is simply too much.

FRANK DANZER,
Detroit

EASTER PROSPECTS.

With Easter near at hand and the continuance of general business depression, the florist is kept in an uncertain frame of mind concerning his purchases for the holiday. It is therefore well for him to consider the situation carefully.

Do not let him fear that the lateness of Easter this year signifies a scarcity of stock, as there will be a sufficiency of cut flowers as well as of flowering plants for the occasion. What is needed is a care in selecting the very best, but in this instance, not the largest flowering plants, Christmas trade in New York having demonstrated that the sale of expensive plants and large lots of cut flowers was exceptional, and by no means the rule.

With favorable weather conditions there is every reason for believing there will be, at least, a fair Easter business all over the country. An impression prevails that in consequence of the stringency of the times flowers will be more generally used as Easter offerings than heretofore, the expense of other articles, such as jewelry, etc., being offered as a reason. Let this, however, not raise the hopes of the retailer and induce him to wade, perhaps, beyond his depth. Better by far he keep close to the shore and use more caution than ever before in selecting a good, but moderate supply. A profitable holiday trade is almost sure to follow.

NEW RETAIL FLOWER STORES.

Joseph Boehm, 62 South St., Utica, N. Y.

Mrs. S. A. Moir, Snow block, Brockton, Mass.

The City Florist, Bush Arcade, Bellefonte, Pa.

A. & J. Hobbs, Portage Ave., Winnipeg, Man.

J. W. Howard, 207 Main St., Charlestown, Mass.

Miss Nola Beck, Fourth and Hanover Sts., Wheeling, W. Va.

NEWS NOTES.

It is said that a tug-of-war between Canadian and United States florists is planned as a part of the festivities of the S. A. F. convention at Niagara Falls next August. The teams are to stand on their respective sides of the Niagara river, the rope spanning the stream.

Maurice Wolff, of Detroit, became the victim of a check manipulator in the person of Geo. R. Muskey, carpenter, 41 years old, of Denver, Colo. With tears raining down his cheeks he ordered a wreath of Mr. Wolff for \$7 and tendered a \$10 check. When Mr. Wolff came to deliver the wreath he found the house empty and his cheque to be forged. He notified other florists at once and when friend Muskey tried the same trick at Schroeder's he was arrested, tears and all.

PROMPT DELIVERY IN BOSTON

AND ALL NEW ENGLAND POINTS
HOUGHTON & CLARK
396 Boylston St., Boston, Mass.



BOSTON'S BEST
In Quality and Design

Can be relied upon when you transfer your retail orders to

EDWARD MACMULKIN
194 Boylston Street, Boston

Send flower orders for delivery in **BOSTON**

and all
NEW ENGLAND POINTS
THOS. F. CALVIN
124 Tremont St., Boston

TRANSFER

Your orders for flower or plant delivery in Eastern New England to

JULIUS A. ZINN,
2 Beacon St., Boston.
Fine Design Work a Specialty.

YALE Orders for flower deliveries to Yale College and all other Connecticut points carefully filled and delivered by
J. N. CHAMPION & COMPANY
1026 CHAPEL STREET NEW HAVEN, CONN.

Decorative Plants

By the Load, Delivered and Arranged to Order at Any Address in Chicago and vicinity. Charge for Use, on Application.

GEORGE WITTBOLD CO.
1657 Buckingham Place, Chicago, Ill.

The Far-Famed Flowers of **TORONTO**

Delivered on mail or telegraph order for any occasion, in any part of the Dominion.

JOHN H. DUNLOP,
96 Yonge St., Toronto, Ont.

ATLANTA FLORAL CO.
41 Peachtree Street, ATLANTA, GEORGIA.

There are some
GOOD BARGAINS
listed in the
BUYERS' DIRECTORY.
Pages 510 to 515, this week.

Special for Easter

FINE SELECTED FANCY or DAGGER FERNS

\$1.25 per 1000. Good Ferns, \$1.00 per 1000.



Bronze Galax

10,000 lots, \$5.00

Green Galax

\$1.00 per 1000 or \$7.50 per 10,000

Wild Smilax

50 pound cases, \$6.00

Do your decoration with our fine Laurel Festooning, 4c, 5c & 6c per yd.
Leucothoe Sprays, Green or Bronze, 40c per 100.
Ground Pine, 5c per lb. or 5c per yd.

NEW SALEM, MASS.

Telegraph Office

L. D. Telephone Connections

INDISPENSABLE

EVERY FLORIST NEEDS IT

EVERLASTING

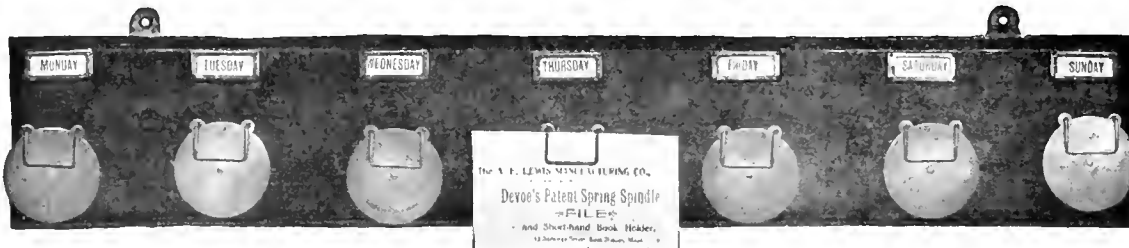

LEWIS'S WEEKLY BOARD FILE

takes the place of Memo, or Order Books, also a line of ovals or of the old fashioned Spike Spindle Sets, from both of which it takes time to remove all but the top paper. Just the thing and the latest device for sale slips, orders to be filled, this week's daily engagements, and a reminder of next week's. The Board File is made up of sets of our Devoe Patent Spring Spindle File. The board is of polished Golden Oak, 30 x 5 inches, with brass name plates to which are the days of the week neatly printed. Cao remove days of week and place Salesman's name in for cashier's desk. Its good points are that it is Cheap, Ornamental a Time Saver, makes 10 holes in the paper, cannot injure operator or Customer. PRICE: Set of 7 on a Board or Florists' use, \$2.00; Set of 6 on a Board (omitting Sunday), \$1.75. Devoe's Spring Spindle Paper File, Typewriters' Note Book, Hat and Reading Book Holder, comes in Mission Green, Mission Black, Polished Golden Oak base, and is the only perfect Spindle File, best and cheapest Note Book Holder. While in use any Paper can be changed or displaced without removing "Memos", Sale Slip, Copy Lists, Etc. SINGLE FILE, 4 in 1, postpaid 25 cts. Wanted—Florist Supply Houses to Handle. State Rights For Sale. THE A. F. LEWIS MFG. CO., BOSTON, MASS.

INCORPORATED.

N. Leakes & Co., New York; David U. Page, R. I. Claus, D. P. Haynie; capital, \$9,000.

BUSINESS CHANGES.

Josepa Leikens, New York, has leased a store near the corner of 56th street and Fifth avenue.

MISSION PLANT BOXES

Large Plants, Bay and Box trees, Palms, Hydrangeas, Agaves, etc., will soon need reporting. Use the Mission Plant Box if you want the most durable and appropriate box made. Very reasonable in price. Made of pine or cypress.



Write for Prices.

Wagner Park Conservatories

SIDNEY, OHIO.

ROBERT J. DYSART,

Public Accountant and Auditor

Simple methods of correct accounting especially adapted for florists' use.

Books Balanced and Adjusted

Merchants Bank Building

28 STATE ST., BOSTON

Telephone, Maio 58.

A LIBERAL OFFER.

The Kramer Bros. Foundry Co. of Dayton, whose advertisement is now running in HORTICULTURE, are practically the only manufacturers in the United States who make a specialty of plant vases. Their vases have many features of special value, such as drain faucet for drawing off superfluous water, adjustable reservoir plates so that they can be removed if customer does not want them in. The pedestals are all made in one piece instead of, as usual, eight or ten pieces, which leave unsightly crevices.

In their campaign to extend the sale of these urns and vases through the florists, Kramer Bros. are willing to send to any florist with a rating, who is interested, a sample line of vases with privilege of returning same if, after a fair trial, he is convinced that he cannot sell them. If he has a nice show room, permission will also be given to fill them with plants for the inspection of customers. This is a liberal proposition which, no doubt, our readers will appreciate.

The German Dahlia Society met on Feb. 23 at Berlin, when details concerning this year's exhibition, the trial of novelties in the palm garden and the worth of certificates were discussed. A show of novelties will be held at Quedlinberg, Sept. 12, 13, 14, at which every member will be permitted to exhibit, besides dahlias, any new plant.

BOSTON FLORIST LETTER CO.

Manufacturers of FLORISTS' LETTERS

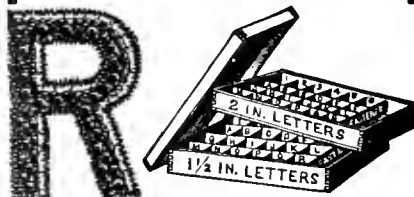

This wooden box nicely stained and varnished, 18x30x12, made in two sections, one for each size letter, given away with first order of 500 letters

Block Letters, 1 1/2 or 2 inch size per 100, \$2.
Script Letters, 3. Fastener with each letter or word. Used by leading florists everywhere and for sale by all wholesale florists and supply dealers

N. F. McCARTHY, Manager
66 Pearl Street, BOSTON, MASS.

The "Japana" Cut Flower Holder

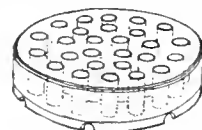

A handy article for florists. Sells to the trade on sight. Made of glass in three sizes.

The "Anglals" Table Decoration, something entirely new, long needed. The florist and housewife will appreciate this article, as it simplifies the art of table decorating.

Ask for catalog.

M. V. CARNSEY, Dept. A,
130 Waiola Ave., La Grange, Ill.

KORAL SCRIPT LETTERS AND EMBLEMS

ONCE USED ALWAYS USED
For sale by all first class supply houses. Made by
KORAL MFG. CO.
26 Hawley St., Boston

SPECIAL OFFERING for EASTER 1908

Your customers will want plants and flowers for Easter if they do not buy at any other time. Order your supply at once and be ready. We have the finest lot of Easter plants we ever handled. Azaleas, Ramblers, Hydrangeas, Spireas, etc., etc. *Send for Complete Price List.*

LILIES (In Pots). 12 1-2c per bud and flower. Have them shipped early as they carry much better. We handle the crop of the best growers in this locality. Perfect in flower and foliage and the proper height.

RHODODENDRONS. Best value for the money in the market. \$1.50 to \$5.00 each.

CUT LILIES. Let us have your order for cut Lilies as they promise to be scarce. 12½c and 15c per bud and flower.

S. S. PENNOCK-MEEHAN CO., "THE" Wholesale Florists Philadelphia, Pa.

EVERYTHING SEASONABLE IN
CUT FLOWERS
EDWARD REID, Wholesale Florist
1526 Ranstead St., PHILADELPHIA
STORE CLOSES 8 P. M.

CUT FLOWER BOXES
EDWARDS FOLDING BOX CO
MANUFACTURERS
PHILADELPHIA, PA.

CHAS. W. MCKELLAR

51 WABASH AVE., CHICAGO-
Western Headquarters for Choice Orchids
Valley, Roses and all Cut Flowers

J. B. Murdoch & Co.

Wholesale Florists
FLORISTS' SUPPLIES
714 Penn Ave., PITTSBURG, PA.
Long Distance Phone 1435 Court.

AMERICAN BEAUTY and all other ROSES
LILY OF THE VALLEY, CARNATIONS
WELCH BROS., 226 Devonshire St., Boston, Mass.

Cut Easter Lilies

Write for Prices
W. E. MCKISSICK WHOLESALE FLORIST
PHILADELPHIA
1619-1621 RANSTEAD ST.

DAILY CONSIGNMENTS

From 40 to 60 Growers
We can care for your cuttlower wants to advantage.
E. F. WINTERSON CO.
45-47-49 WABASH AVE., CHICAGO

Rice Brothers

115 N. 6th Street, MINNEAPOLIS, MINN.
WHOLESALE FLORISTS and SUPPLIES
CUT FLOWERS received twice daily, and can fill your orders to your satisfaction. A complete line of Hardy Greens—WILD SMILAX, BOXWOOD, HARDY FANCY FERNS, GALAX LEAVES.
Write for quotations on large quantities.

H. BAYERSDORFER & CO.

The Florists' Supply House of America
Send for Illustrated Catalogue
1129 ARCH ST., PHILA., PA.

Alex Mann, Jr. Co. Inc.

Wholesale Dealer in
Florists' Supplies and Cut Flowers
White Doves, \$9.00 per doz.
Galax Leaves.
1125 Polk Street, San Francisco, Cal.

WHOLESALE FLOWER MARKETS—TRADE PRICES—Per 100 TO DEALERS ONLY

	CHICAGO April 6	TWIN CITIES April 6	PHILA. April 6	BOSTON April 9
ROSES				
Am. Beauty, Fancy and Special	25.00 to 45.00	45.00 to 60.00	20.00 to 25.00	15.00 to 25.00
Extra	25.00 to 35.00	30.00 to 40.00	12.00 to 15.00	10.00 to 15.00
No. 1	2.50 to 15.00	15.00 to 25.00	6.00 to 8.00	8.00 to 10.00
Lower grades	4.50 to 8.00	10.00 to 15.00	3.00 to 5.00	4.00 to 6.00
Bride, 'Maid, Fancy & Special	8.00 to 10.00	8.00 to 10.00	8.00 to 10.00	6.00 to 8.00
Extra and No. 1	4.00 to 5.00	6.00 to 8.00	4.00 to 6.00	3.00 to 5.00
Lower grades	3.00 to 4.00	4.00 to 6.00	2.00 to 3.00	1.00 to 2.00
Killarney, Richmond, Fan & Sp.	8.00 to 10.00	8.00 to 10.00	8.00 to 10.00	12.00 to 14.00
Lower grades	4.00 to 6.00	3.00 to 6.00	3.00 to 5.00	2.00 to 6.00
Chatnay, Wellesley, Fan & Sp.	8.00 to 10.00	8.00 to 10.00	8.00 to 10.00	12.00 to 14.00
Lower grades	4.00 to 6.00	3.00 to 6.00	3.00 to 5.00	1.00 to 3.00
Golden Gate, Ivory	4.00 to 8.00	5.00 to 8.00	3.00 to 8.00	1.00 to 6.00
CARNATIONS				
Fancy and Novelties	1.00 to 3.00	2.50 to 3.50	3.00 to 4.00	2.00 to 3.00
Ordinary	1.00 to 2.00	1.50 to 2.00	1.50 to 2.00	1.00 to 2.00
MISCELLANEOUS				
Violets	.50 to .75	.75 to 1.25	.50 to .75	.25 to .50
Cattleyas	50.00 to 60.00	50.00 to 60.00	50.00 to 60.00	50.00 to 60.00
Cypripediums	12.00 to 15.00	10.00 to 15.00	12.50 to 15.00	6.00 to 10.00
Lilies	3.00 to 4.00	2.00 to 3.50	2.00 to 4.00	1.00 to 3.00
Lily of the Valley	50 to 1.00	1.00 to 2.00	1.00 to 2.00	1.00 to 1.50
Daisies	2.00 to 3.00	3.00 to 4.00	3.00 to 4.00	3.00 to 4.00
Daffodils	4.00 to 6.00	4.00 to 6.00	4.00 to 6.00	4.00 to 6.00
Tulips	20.00 to 35.00	40.00 to 50.00	10.00 to 15.00	25.00 to 40.00
Mignonette	1.00 to 1.50	1.00 to 1.50	1.00 to 1.50	1.00 to 1.50
Gardenias	.50 to .75	1.00 to 1.50	.75 to 1.00	.50 to 1.00
Lilac per bush	.75 to 1.00	.75 to 1.00	1.00 to 1.50	1.00 to 1.50
Sweet Peas	75 to 1.00	75 to 1.00	1.00 to 1.50	1.00 to 1.50
Africanum	12.00 to 15.00	12.00 to 15.00	15.00 to 20.00	10.00 to 12.00
Whitmanii Fronds	35.00 to 50.00	35.00 to 50.00	50.00 to 60.00	25.00 to 50.00
Smilax	35.00 to 50.00	35.00 to 50.00	50.00 to 60.00	25.00 to 50.00
Asparagus Plumosus, strigs.	35.00 to 50.00	35.00 to 50.00	50.00 to 60.00	25.00 to 50.00
" & Sprea (100 behs.)	35.00 to 50.00	35.00 to 50.00	50.00 to 60.00	25.00 to 50.00

J.A. BUDLONG

37-39 Randolph Street, CHICAGO.

Roses and Carnations WHOLESALE CUT FLOWERS
A Specialty..... GROWER of

E. A. BEAVEN
Southern Wild Smilax,
Log Mosses,

The best Fancy and Dagger Ferns on the Market. For Easter, \$1.50 per thousand. Guaranteed.

Natural and Perpetuated—at Wholesale,
EVERGREEN, ALABAMA.

H. J. SMITH
HINSDALE - MASS.

EASTER PLANTS

**Azaleas, Baby Ramblers,
Hydrangeas, Lilies,
Geraniums**

In fine condition. Write for Prices

WM. W. EDGAR CO., Waverley, Mass.

**Lilies for Easter
CUT AND PLANTS**

Prices on application.

We handle the crop of the best growers in this vicinity.

The Leo Niessen Company
1209 Arch St., Philadelphia, Pa.
Open from 7 a. m. to 8 p. m.

FLOWER MARKET REPORTS

BOSTON Cut-flower trade is in bad shape here this week. It is not that the supply is too heavy, for it is no greater than at a corresponding date last year, but simply that the buyers seem to have ceased to buy for the time being. Yet the advance buying for Easter is exceedingly good and to this extent, at least, the situation is very encouraging. At the present time roses seem to be the greatest sufferers. Carnations are less abundant than they were and surpluses are depleted sufficiently to help materially towards a better return from wholesale markets. Violets are also showing a slight but unmistakable improvement.

Every one hopeful for the Easter outlook is bright. Roses, lilies and carnations are coming in freely and the demand is fairly good. The quality of stock is excellent. Violets, daffodils, tulips, lily of the valley, all are selling at fairly satisfactory prices.

Considering the slowness of sales made society must take the season of Lent rather seriously. Everybody has plenty of flowers and just as much time to turn these flowers into money. According to Messrs. G. Heintz and F. McGee, of Toledo, who were visitors last week, business there is about the same. While we have plenty of lilies for Easter there must be a shortage up the state because the Michigan Cut Flower Exchange is expressing large quantities of potted lilies daily.

INDIANAPOLIS Bullbous stock and lilies are advancing very rapidly and some apprehension is felt as to what kind of shape they will be in for Easter. Beauties and teas are now at the height of perfection and are disposed of at prices satisfactory to grower and retailer. Carnations are a little ahead of demand but so far no bargain counter sales have been advertised. Easter lilies and callas are in fair supply but move slowly. Violets are getting toward the end of their season. An abundance of fine sweet peas is to be had and sells well, while lily of the valley is only in light demand. Adiantum and asparagus are good property now. The retailers all report an exceptionally active week. Plant trade in particular is picking up.

both inexpensive and high grade selling readily.

NEW YORK The stagnation in the flower market in this city continues unabated. Indeed, it may truthfully be said that last week's market touched the lowest point ever reached in the experience of the longest established dealers. The quality of stock coming in is very heavy on all lines, and the situation suggests that possibly there may be an unexpected shortage for Easter on some things which the frequent warm days are driving to maturity more rapidly than the growers like to see. Lilies are already quite abundant in wholesale establishments, the majority of them having stalks shorter than ever before. Quality, in roses particularly, is very high.

PHILADELPHIA Stocks cleaned up a little better last week, and while no material advance has taken place in prices, the conditions are on the whole more favorable. We must expect carnations from this. These did not hold their own as compared with the previous improvement reported. Roses remained normal. Beauties not so plentiful. White roses in heavy supply. Medium priced reds the best sellers. Cattleyas, oncidiums and dendrobiums were in good demand with supply on the short side. Any amount of good lily of the valley can be had at prices that please the buyer very much. As the spring advances sweet peas seem to increase in favor, but prices are low. Single violets show effect of the waning season. Doubles still pretty good. Pink antirrhinum

a dainty quickly snapped up. Swainsona if long stemmed a good seller. Greens are in good healthy condition with supply and demand well regulated. Many strangers have been in town recently looking things over and the Easter plant bookings are reported brisk. Forsythias and some other spring shrubbery have commenced. The growers of indoor stock are hoping for cold weather until Easter, so as to keep all that demoralizing influx in abeyance. Southern daffodils, as well as home grown bulbous stock of all kinds, are over the crisis and now much easier to handle.

WINNIPEG Bath pot and cut flowers are selling well, although trade is still rather quiet, consequent on a large number of people wintering away from the city, but in the greenhouses plants and blooms for Easter are coming along splendidly.

NEWS NOTES.

G. S. Ramsburg of Somersworth, N. H., has secured the contract from the G. A. R. decoration committee of Dover, N. H., for Memorial Day.

Reports from the South show that the unprecedented warm weather has cut short the shipping season for nursery stock by at least three weeks.

On Tuesday, April 7, at Cleary's Horticultural Co., New York, announcement is made of a "Defiance Sale" of roses, trees, shrubs and bulbs. Catalogue can be had on application. Ambrose T. Cleary will wield the auctioneer hammer.

Bostrom Improved Builders' Levels and Farm Levels



For Park, Cemetery and Landscape Gardening use, take the place of expensive Engineering Instruments. Simple in construction, easily adjusted, more substantial and less cumbersome than the more elaborate and complicated instruments. Practical, up-to-date instrument that any one can use. Write for descriptive circulars and be convinced that this Level is necessary to complete your outfit. Builders' Level \$25.00. Farm Level \$32.50.

BOSTROM-BRADY MFG CO., 139 Madison Avenue, ATLANTA, GA.

The KERVAN CO. 113 W. 28th ST. New York

WHOLESALE DEALERS

Fresh cut Palmetto & Cycas Palm Leaves, Galax, Leucothoe, Ferns and Mosses. All Decorating Evergreen.

There are some
GOOD BARGAINS
listed in the
BUYERS' DIRECTORY,
Pages 510 to 515, this week.

JOHN YOUNG
WHOLESALE FLORIST
 Finest American Beauties and Carnations
 51 West 28 St. - NEW YORK

FORD BROTHERS
 48 West 28th Street, NEW YORK
FINE ROSES FANCY CARNATIONS
 A Full Line of All CUT FLOWERS
 Telephone, 3870 or 3871 Madison Square

H. E. FROMENT,
 Wholesale Commission Florist,
 Choice Cut Flowers,
 57 West 28th St., :: NEW YORK.
 Telephones: 2200, 2201, Madison Square.

The Reliable Commission House
 Richmond Roses and Rich Flowers
 of all varieties
JOS. S. FENRICH
 110 W. 28th Street, New York
 Tel. 324-325 Madison Square

Established 1891 BUY FROM SHIP TO TRY **ME**
ALFRED H. LANGJAHR
 All Choice Cut Flowers In Season
 55 West 28th St., New York
 Telephone 3924 Madison Square.

JOHN I. RAYNOR
Wholesale Commission Florist SELLING AGENT FOR LARGEST GROWERS
 A full line of Choice Cut Flower stock for all purposes. Comprises every variety grown for New York market, at current prices
 TEL. 1998 MADISON SQUARE 49 W. 28 St., New York City

Walter F. Sheridan
 Wholesale Commission Dealer in
CHOICE CUT FLOWERS
 39 West 28th Street, New York
 Telephone: 3532-3533 Madison Square

HEADQUARTERS FOR NOVELTIES
ORCHIDS A SPECIALTY
 THE HIGHEST GRADE OF **VALLEY** ALWAYS ON HAND
 GARDENIAS, DAISIES, ROSES AND CARNATIONS
 Telephone
JAMES McMANUS, 753 Mad. Sq. 42 W. 28th St., New York

PHILIP F. KESSLER 55 & 57 W. 26th St., New York City
 Commission Dealer, Wholesale Buyer and Seller of
CUT FLOWERS
 Open from 5 a. m. to 6 p. m. Sunday till 10 a. m.
 Tel., 5243 and 2921 Madison Sq. Res., 345 J., Newtown.
Finest Lilies in the Market Every Day in the Year.

WHOLESALE COMMISSION FLORIST **J. K. ALLEN** 106 W. 28 ST. NEW YORK
 Telephone 167 Madison Sq.
 OPEN 6 A.M. DAILY
 We have a good regular outlet for seasonable flowers

NEW YORK QUOTATIONS PER 100—TO DEALERS ONLY

	Last Half of Week ending April 4 1908	First Half of Week beginning April 6 1908	Last Half of Week ending April 4 1908	First Half of Week beginning April 6 1908
Roses				
Am. Beauty, Ian and sp.	10.00 to 20.00	10.00 to 20.00		
" extra	6.00 to 8.00	6.00 to 8.00		
" No. 1	3.00 to 5.00	3.00 to 6.00		
" Lower grades to 1.00 to 1.00		
Bride, 'Maid, Ian and sp.	3.00 to 5.00	3.00 to 5.00		
" extra	1.00 to 2.00	1.00 to 2.00		
" lwr. grds.	.50 to 1.00	.50 to 1.00		
Killarney, Richmond, fancy & spec	6.00 to 12.00	6.00 to 12.00		
" lower grades	.50 to 3.00	.50 to 3.00		
Chateaub, Wellesley, Ian. and spec.	4.00 to 10.00	4.00 to 10.00		
" lower grades	.50 to 2.00	.50 to 2.00		
Golden Gate, Ivory	.50 to 4.00	.50 to 4.00		
Carnations, Fancy and Novelties	1.00 to 2.00	1.00 to 2.00		
" Ordinary	.50 to .75	.50 to .75		
Violets	.10 to .25	.10 to .25		
Cattleyas	40.00 to 50.00	40.00 to 50.00		
Cypripediums	8.00 to 10.00	8.00 to 10.00		
Lilies	6.00 to 8.00	6.00 to 8.00		
Lily of the Valley	1.00 to 2.00	1.00 to 2.00		
Freesia	1.00 to 1.50	1.00 to 1.50		
Daffodils to 1.00 to 1.00		
Tulips to 1.00 to 1.00		
Mignonette to 2.00 to 2.00		
Gardenias	25.00 to 35.00	25.00 to 35.00		
Lilac per bunch to .50 to .50		
Sweet Peas	.50 to .60	.50 to .60		
Adiantum	.75 to 1.00	.75 to 1.00		
Smilax	8.00 to 12.00	8.00 to 12.00		
Asparagus Plumosus, strigis.	25.00 to 35.00	25.00 to 35.00		
" & Spreo. (too bchs.) to 10.00 to 10.00		

B. S. SLINN, Jr.
 —WHOLESALE FLORIST—
 55 & 57 W. 26th St., New York City
 Tel., 3864 Madison Sq. Shipping Orders Solicited,
VIOLETS Roses and Carnations

TRAENDLY & SCHENCK
WHOLESALE FLORISTS
 Furnish best stock at fair prices all the year round Send for quotations on fall orders
 Tel. 798-799 Madison Sq. 44 West 28th Street, New York City

Edward C. Horan
Wholesale Florist
 55 WEST 28th ST.
 Tel. 1462 Madison Square New York

Alexander J. Guttman
THE WHOLESALE FLORIST OF NEW YORK
 43 WEST 28th STREET
 PHONES. 1664--1665 MADISON SQUARE
ENOUGH SAID



HARDY CUT FERNS

Sphagnum Moss, Extra Large Bales, per bale, \$1.25. Fancy and Dagger Ferns our specialty. A trial order will convince you that we ship only first-class stock. Headquarters for Florists' supplies and wire work. All cut flowers in season. **BOXWOOD**, per bunch 35c, 50 lbs. \$7.50.

MICHIGAN CUT FLOWER EXCHANGE, INC., All 'phone connections 38-40 Broadway, Detroit, Mich.

FANCY and DAGGER
Extra fine, \$1.75 per 1000. Brouze and Green Galax, \$1.25 per 1000. Leucothoe Sprays, \$1.00 per 100, \$7.50 per 1000.

Headquarters in Western New York
FOR
ROSES, GARNATIONS
And all kinds of Seasonable Flowers
Wm. F. Kasting Co.
Wholesale Commission Florist, also Dealer in
Florists' Supplies and Wire Designs.
383-87 ELLICOTT ST.
BUFFALO, N. Y.
Give us a trial. We can please you.

FRANK S. HICKS & CO.
Wholesale Florists.
Open Now for Consignments of Cut Flowers.
52 West 28th Street, - New York City
Tel. 2920 Mad. Sq.

FRANK MILLANG
Wholesale Florist
Telegraphic Orders Filled and Delivered.
55-57 West 26th St., New York City.

HENRY M. ROBINSON & CO.
Wholesale and Commission
FLORISTS
Hardy Cut Evergreens and Florists' Supplies
15 Province St. and 9 Chapman Place,
BOSTON, MASS.

Flowers and
Florists' Supplies
The best place in AMERICA to buy
BAY TREES
N. F. McCarthy & Co.
84 Hawley St., BOSTON, MASS.
Large Retail Dealers in Supplies in New England.

WHOLESALE FLOWER MARKETS. — PER 100. — TO DEALERS ONLY.

	CINCINNATI April 6	DETROIT April 6	BUFFALO April 6	PITTSBURG April 6
ROSES				
Am. Beauty, Fan. and Sp.....	25.00 to 35.00	25.00 to 35.00	20.00 to 30.00	20.00 to 25.00
“ Extra	15.00 to 25.00	15.00 to 25.00	15.00 to 2.00	10.00 to 15.00
“ No. 1	10.00 to 15.00	10.00 to 15.00	8.00 to 10.00	8.00 to 15.00
“ Lower grades.....	4.00 to 8.00	4.00 to 8.00	3.00 to 8.00	8.00 to 12.00
Bride, 'Maid, F. & S.....	8.00 to 10.00	8.00 to 10.00	10.00 to 10.00	10.00 to 10.00
“ Extra	6.00 to 8.00	6.00 to 8.00	6.00 to 6.00	6.00 to 8.00
“ Low. gr.	3.00 to 4.00	3.00 to 4.00	3.00 to 4.00	4.00 to 5.00
Killarney, Richmond, Fan. & Sp...	8.00 to 10.00	6.00 to 10.00	10.00 to 10.00	4.00 to 10.00
“ Lower grades.....	4.00 to 6.00	3.00 to 4.00	3.00 to 6.00	4.00 to 4.00
Chateaux, Wellesley, Fan. & Sp...	6.00 to 8.00	6.00 to 10.00	10.00 to 15.00	6.00 to 8.00
“ Lower grades.....	4.00 to 5.00	3.00 to 4.00	7.00 to 10.00	4.00 to 6.00
Golden Gate, Ivory.....	4.00 to 6.00	3.00 to 4.00	3.00 to 8.00	4.00 to 6.00
CARNATIONS				
Fancy and Novelties.....	1.00 to 3.00	2.00 to 1.00	2.00 to 3.00	2.00 to 3.00
Ordinary	1.00 to 2.00	1.00 to 1.50	1.00 to 2.00	1.00 to 1.50
MISCELLANEOUS				
Violets50 to .75	.75 to 1.00	.40 to .75	.25 to .75
Cattleyas	40.00 to 50.00	35.00 to 50.00	40.00 to 60.00	40.00 to 75.00
Cypripediums
Lilies	10.00 to 12.50	12.50 to 15.00	4.00 to 15.00	6.00 to 12.00
Lily of the Valley.....	3.00 to 4.00	2.00 to 4.00	2.00 to 4.00	3.00 to 4.00
Daisies.....	1.00 to 2.00	2.00 to 2.00
Daffodils.....	2.00 to 3.00	2.00 to 3.00	2.00 to 3.00	1.50 to 2.00
Tulips	2.00 to 4.00	4.00 to 8.00	2.00 to 5.00	2.00 to 4.00
Mignonette.....	35.00 to 50.00	15.00 to 25.00
Gardenias.....
Lilac per bunch.....	1.50 to .50	1.00 to .50	.50 to .75
Sweet Peas50 to .75	.50 to 1.50	.40 to 1.00	.50 to .75
Adiantum75 to 1.50	.50 to 1.00
Whitmanii Fronds.....	8.00 to 10.00
Smilax	10.00 to 12.00	10.00 to 15.00	12.50 to 15.00
Asparagus Plumosus, strings.....	40.00 to 50.00	35.00 to 50.00	40.00 to 60.00
“ & Sprea (100 bchs.)	25.00 to 35.00	30.00 to 50.00

SAMUEL A. WOODROW
WHOLESALE PLANTSMAN
Palms, Large and Small Ferns, etc.
53 West 30th Street, NEW YORK
Telephone 2083 Madison

WILLIAM H. KUEBLER
Brooklyn's Foremost and Best
WHOLESALE COMMISSION HOUSE
A First Class Market for all CUT FLOWERS
28 Willoughby St., Brooklyn, N. Y.
Tel. 4591 Main

CLEARY'S HORTICULTURAL CO.
Management AMBROSE T. CLEARY
Wholesale Contracting, Jobbing, Auction
HORTICULTURAL PRODUCTS
of every description.
Consignments Received. Surplus Stock Converted.
62 Vesey St., NEW YORK

Moore, Hentz & Nash,
Wholesale Commission Florists,
55 and 57 West 26th Street,
Telephone No. 756
Madison Square. **New York.**

H. C. BERNING
Wholesale Florist
1402 Pine Street, ST. LOUIS, MO.

MILLANG BROS.
WHOLESALE COMMISSION FLORISTS
41 West 28th Street
Telephone 3860
Madison **NEW YORK**

A. MOLTZ
Will purchase flowers on order in
N. Y. market and ship carefully at
prevailing wholesale prices. Address
55-57 West 26th Street, New York City

REED & KELLER
122 West 25th St., New York
Florists' Supplies
We manufacture all our
Metal Designs, Baskets, Wire Work & Novelties
and are dealers in
Glassware Decorative Greene and Florists' Requisites.

In writing to Advertisers kindly mention Horticulture

Buyer's Directory and Ready Reference Guide

Advertisements under this head, one cent a word. Initials count as words.

Regular advertisers in this issue are also listed under this classification without charge. Reference to List of Advertisers will indicate the respective pages.

Buyers failing to find what they want in this list will confer a favor by writing us and we will try to put them in communication with reliable dealers.

ACCOUNTANT

R. J. Dysart, 28 State St., Boston.
For page see List of Advertisers.

ALTERNANTHERAS

Red Alternantheras at 40 cents per 100.
C. W. Moeckel, 17 Summer St., Fitchburg, Mass.

AQUATIC PLANTS

Aquarium plants the year round. Wholesale and retail. Send for price list. Schold's Emporium of Pets, 712 12th Street, Washington, D. C.

ARAUCARIAS

Godfrey Aschmann, 1012 Ontario St., Philadelphia, Pa.
For page see List of Advertisers.

ASPARAGUS

A. N. Pierson, Cromwell, Conn.
Asparagus Plumosus Seedlings.
For page see List of Advertisers.
Asparagus plumosus and Sprenger, 2-in., strong, \$2.00 per 100. J. H. Dann & Son, Westfield, N. Y.
Asparagus Plumosa, 2 in. pots. Fine plants, \$3.00 per 100; \$25.00 per 1000. Cash with order or good reference. Erle Floral Co., Erie, Pa.; or, Wm. F. Kastling Co., 385 Elliott St., Buffalo, N. Y.

AUCTION SALES

Cleary's Horticultural Co., 62 Vesey St., New York.
Horticultural Products of Every Description.
For page see List of Advertisers.
Wm. Elliott & Sons, 201 Fulton St., New York.
For page see List of Advertisers.

AZALEAS

A. Leuthy & Co., Perkins St. Nurseries, Roslindale, Mass.
For page see List of Advertisers.
W. W. Edgar Co., Waverley, Mass.
For page see List of Advertisers.
August Rolker & Sons, New York, 31 Barclay St., or P. O. Box 752.
For page see List of Advertisers.
Godfrey Aschmann, 1012 W. Ontario St., Philadelphia.
For page see List of Advertisers.
Azalea amoena, young plants, 85, \$10 and \$15 per 100. Fine plants full of buds, \$50 per 100; 2 1/2 to 3 ft., \$100 per 100. Ask for list of trees and shrubs in variety. Samuel C. Moon, Morrisville, Pa.

BAMBOO CANES

Stump & Walter Co., 50 Barclay St., New York.
For page see List of Advertisers.
Yokohama Nursery Co., 31 Barclay Street, New York.
For page see List of Advertisers.

BAY TREES.

N. F. McCarthy & Co., 84 Hawley St., Boston.
For page see List of Advertisers.
Bay Trees and Box Trees, standards and pyramids. All sizes. Price list on application. J. Roehrs Co., Rutherford, N. J.

BEDDING PLANTS

R. Vincent, Jr., & Sons Co., White Marsh, Maryland.
For page see List of Advertisers.

BEGONIAS

10,000 Begonia Vernon, 2 in., 2c. M. Fenton, West Newton, Pa.
Begonia Pres. Carnot, 2 1/2 in., \$3.00 100. Valley Greenhouse Co., Sewickley, Pa.

BOILERS

BOILERS. "Burnham" Boilers made for greenhouse heating. Lord & Burdham, 1133 Broadway, N. Y.

BOXWOOD

Henry M. Robinson & Co., 15 Province St., Boston.
For page see List of Advertisers.

BUILDERS' AND FARM LEVELS

Bostrom-Brady Mfg. Co., 139 Madison Ave., Atlanta, Ga.
For page see List of Advertisers.

BUILDING MATERIAL

BUILDING MATERIAL of all description for All Cypress, Scent-Iron, Iron Frame or Truss houses. Hot Bed Sash and Frames. Lord & Burnham Co., 1133 Broadway, N. Y.

BULBS AND TUBERS

Joseph Breck & Sons, 47-54 N. Market St., Boston.
For page see List of Advertisers.
J. M. Thornburn & Co., 33 Barclay St., New York.
For page see List of Advertisers.
A. T. Boddington, 342 W. 14th St., N. Y.
For page see List of Advertisers.
Rickarda Bros., 37 East 19th St., New York.
For page see List of Advertisers.
H. F. Mitchell Co., Philadelphia.
For page see List of Advertisers.
H. E. Flske Seed Co., Faneull Hall Sq., Boston.
For page see List of Advertisers.
James Vick's Sons, Rochester, N. Y.
Fall Bulbs.
For page see List of Advertisers.
D. Ruscou, 123 W. Sixth St., Cincinnati, O.
Cold Storage.
For page see List of Advertisers.
Aug. Rolker & Sons, 31 Barclay St., New York.
Seasonable Import Plants and Bulbs.
For page see List of Advertisers.

K. Velthuys, Hillegom, Holland,
Represented by Felix Bosch, 260 Clarendon St., Boston.

Bulbs French and Dutch.
For page see List of Advertisers.
Ralph M. Ward & Co., 2 W. Broadway, New York, Agts. for Martini Bremond, Orlonles, France.
French Bulbs.
For page see List of Advertisers.

Stump & Walter Co., 50 Barclay St., New York.
Canna Bulbs.
For page see List of Advertisers.
V. H. Hallock & Son, Queens, N. Y.
Lilium Auratum and Double Begonia Bulbs.

CANNAS

The Conard & Jones Co., West Grove, Pa.
For page see List of Advertisers.
J. B. Shurtleff & Son, Cushman Ave., Revere, Mass.
Live Cannas Started from Sand.
For page see List of Advertisers.

CARNATIONS

F. Dorner & Sons Co., Lafayette, Ind.
For page see List of Advertisers.
S. S. Skidelaky, 1741 N. 18th St., Philadelphia.
For page see List of Advertisers.
Chicago Carnation Co., Joliet, Ill.
For page see List of Advertisers.
John E. Haines, Bethlehem, Pa.
Carnations Imperial and Pluk Imperial.
For page see List of Advertisers.
Chas. H. Totty, Madison, N. J.
For page see List of Advertisers.

CARNATIONS—Continued

A. N. Pierson, Cromwell, Conn.
For page see List of Advertisers.
Strong, Fair Maid, \$1.00 per 100. Write for others. Saturated for sale. Otto Bourdy, Lowell, Mass.
White Enchantress, unrooted cuttings. Write for prices. Won first prize for best vase of 50. F. H. Westhoff, De Haven, Pa.
Carnation cuttings of all the leading varieties at the same price as any reliable firm. Write for prices before you look elsewhere. Wm. F. Kastling Co., 383 Elliott St., Buffalo, N. Y.

CHRYSANTHEMUMS

Chas. H. Totty, Madison, N. J.
Single Chrysanthemums.
For page see List of Advertisers.
A. N. Pierson, Cromwell, Conn.
For page see List of Advertisers.
Chrysanthemums. 5000 unrooted cuttings of Yellow Bonnaifon, 70c. per 100. F. H. Westhoff, De Haven, Pa.
Have 100,000 fine young well-rooted 'Mums, cuttings of the best 60 commercial varieties. Send for our new and low price list. Satisfaction guaranteed. Wm. Edmund, Jr., Corfu, N. Y.

Chrysanthemums ready: 2 1/2 inch strong stock of Touset, Oct. Frost, Polly Rose, Wauamaker, and all standards, \$3 per 100, \$25 per M. New: 2 1/2 inch, strong, Alice Rooaevelt, Hankey, Clay Frick, Winter Cheer, Rosette, B. May, \$5 per 100, \$40 per M. Cash. Send for catalog. Harlowarden Greenhouses, Greenport, N. Y.

COLEUS

Coleus cuttings, 60c. 100; 2 in., 2c. mixed. M. Fenton, West Newton, Pa.
Coleus Golden Bedder, Verschaffelt, 2 in. \$2.00 100; rooted cuttings, 60c. 100. Valley Greenhouse Co., Sewickley, Pa.
Coleus, Golden Bedder, Verschaffelt, and mixed Coleus, rooted cuttings, 60c. per 100; \$5.00 per 1000. Cash with order. J. E. Peithouse, Florist, Schenectady, N. Y.

CONIFERS

John Waterer & Sons, Ltd., American Nursery, Bagshot, Eng.
For page see List of Advertisers.
New England Nurseries, Bedford, Mass.
For page see List of Advertisers.

CUT FLOWER BOXES.

Edwards Folding Box Co., Philadelphia.
For page see List of Advertisers.
Folding cut flower boxes, the best made. Write for list. Holton & Huukel Co., Milwaukee, Wis.

DAHLIAS

David Herbert & Son, Atco, N. J.
For page see List of Advertisers.
J. L. Moore, Northboro, Mass.
For page see List of Advertisers.
Henry A. Dreer, 714 Chestnut St., Philadelphia.
For page see List of Advertisers.
Wm. F. Turner & Co., New Bedford, Mass.
Ruth Forbes and Newport.
15,000 Field-grown clumps 2c. and up. List ready. H. W. Koerner, Sta. B, Milwaukee, Wis.
Dahlia Bulbs, 25 choice named varieties, 1-3 Cactus, for \$1. Catalog free. C. Peirce, Dighton, Mass.
Dahlias: About 2000 Cath. Duer, Kriemhilde, Bruuhilde, Snowlad, etc., \$3 per 100. Cash. Harlowarden Greenhouses, Greenport, N. Y.

For List of Advertisers See Page 516

DAHLIAS—Continued

Dahlias. Novelties and standard varieties, true to name, a choice list of the best introductions. Send for catalogue of dahlias, hollyhocks, hardy plants, etc. W. W. Wilmore, Box 382, Denver, Colo.

Dahlia Roots—Undivided field clumps, Lyndhurst, Maid of Kent, William Agnew, White Swan, Kreimhilde, John Walker, Arabella and A. D. Livoni. Write for low prices. Wood & Healey, Hammoncton, New Jersey.

The East Bridgewater Dahlia Gardens have 50 varieties of up-to-date dahlias to offer in full field clumps just as dug. Over 200,000 clumps. Send to the eastern dahlia king for rock bottom price list. J. K. Alexander, East Bridgewater, Mass.

Cactus, Decorative, Show, Fancy and Pompon Dahlias. 75 leading varieties to select from. Strong divided clumps, in 10 or 20 varieties, my selection at \$3.00 per 100; \$25.00 per 1000. Single Dahlias, mixed, \$1.00 per 100. Cash with order please. Hermann Thiemann, Monson, Mass.

DECORATIVE PLANTS

A. Leuthy & Co., Perkins St. Nurseries, Roslindale, Mass.
For page see List of Advertisers.

EASTER PLANTS

Wm. W. Edgar Co., Waverley, Mass.
For page see List of Advertisers.

A. Leuthy & Co., Perkins St. Nurseries, Roslindale, Mass.
For page see List of Advertisers.

Godfrey Aschmann, 1012 W. Ontario St., Philadelphia.
For page see List of Advertisers.

S. S. Pennock-Meehan Co., Philadelphia.
For page see List of Advertisers.

EUONYMUS RADICANS

Euonymus radicans, 1—1 1/2 ft., \$6.00; 2—2 1/2 ft., \$8.00 per 100. Bushy plants. Brae-Burn Nursery, West Newton, Mass.

EVERGREENS

The New England Nurseries, Bedford, Mass.
For page see List of Advertisers.

Evergreens—Colorado spruce, 6 to 8 ft.; Norway spruce, 10 to 14 ft.; Eastern spruce 6 to 8 ft.; Nordmann's fir, 4 to 6 ft., also 1 to 2 ft. Small evergreens for nursery planting, in great variety. Ask for list. Samuel C. Moon, Morrisville, Pa.

FERNS

A. Leuthy & Co., Roslindale, Mass.
For page see List of Advertisers.

H. H. Barrows & Son, Whitman, Mass
Nephrolepis Whitmanii.
For page see List of Advertisers.

Godfrey Aschmann, 1012 Ontario St., Philadelphia, Pa.
For page see List of Advertisers.

John Scott, Brooklyn, N. Y.
For page see List of Advertisers.

Baur Floral Co., Erie, Pa.
For page see List of Advertisers.

Nephrolepis Exaltata Bostoniensis, fine young plants, \$10.00 per 1000.
N. Elegantiissima, young plants \$15.00 per 1000. Send for price list. Soar Bros. Little River, Fla.

FERTILIZERS

Pulverized Manure Co., 31 Union Stock Yards, Chicago, Ill.
Wizard Brand Cattle Manure.
For page see List of Advertisers.

Thos. J. Grey & Co.,
32 and 33 South Market St., Boston.
High-Grade Scotch Soot.
For page see List of Advertisers.

FLORAL PHOTOGRAPHS

Floral Photographs. Foley's 226-228 1-2 Bowery, New York.

FLORISTS' LETTERS.

Boston Florist Letter Co., 68 Pearl St., Boston, Mass.
For page see List of Advertisers.

Koral Mfg. Co., 26 Hawley St., Boston.
For page see List of Advertisers.

FLORISTS SUPPLIES

N. F. McCarthy & Co., 84 Hawley St., Boston.
For page see List of Advertisers.

H. M. Robinson & Co., 15 Province St. and 9 Chapin Pl., Boston, Mass.
For page see List of Advertisers.

The Keivan Co., 113 W. 28th St., N. Y.
Decorative Evergreens.
For page see List of Advertisers.

Reed & Keller, 122 W. 25th St., New York.
For page see List of Advertisers.

J. B. Murdock & Co., 714 Penn Ave., Pittsburg, Pa.
For page see List of Advertisers.

H. Bayersdorfer & Co., 1129 Arch St., Philadelphia.
For page see List of Advertisers.

Alex. Mann, Jr., Co., 1125 Polk St., San Francisco, Calif.
For page see List of Advertisers.

FLOWERS BY TELEGRAPH

Park Floral Co., Denver, Colo.
For page see List of Advertisers.

J. N. Champlin & Co., 1026 Chapel St., New Haven, Conn.
For page see List of Advertisers.

George H. Cooke, Washington, D. C.
For page see List of Advertisers.

Gude Bros. Co., 1214 F St., Washington, D. C.
For page see List of Advertisers.

Atlanta Floral Co., Atlanta, Ga.
For page see List of Advertisers.

M. C. & J. E. Hauswirth, 232 Michigan Ave., Chicago.
For page see List of Advertisers.

William J. Smyth, Michigan Ave. and 31st St., Chicago.
For page see List of Advertisers.

Jacob Schulz, 644 4th Ave., Louisville, Ky.
For page see List of Advertisers.

Thos F. Galvin, 124 Tremont St., Boston.
For page see List of Advertisers.

Julius A. Zinn, 2 Beacon St., Boston.
For page see List of Advertisers.

Houghton & Clark, 396 Boylston St., Boston.
For page see List of Advertisers.

Sidney Hoffman, 59-61 Massachusetts Ave., Boston.
For page see List of Advertisers.

Edward MacMullin, 194 Boylston St., Boston.
For page see List of Advertisers.

J. Breitmeyer's Sons, Miami and Gratiot Aves., Detroit, Mich.
For page see List of Advertisers.

Samuel Murray, 1017 Broadway, Kansas City, Mo.
For page see List of Advertisers.

Wm. L. Rock Flower Co., 1116 Walnut St., Kansas City, Mo.
For page see List of Advertisers.

Fred C. Weber, 4326-28 Olive St., St. Louis, Mo.
For page see List of Advertisers.

H. G. Eyrea, 11 N. Pearl St., Albany, N. Y.
For page see List of Advertisers.

David Clarke's Sons, 219-2141 Broadway, New York.
For page see List of Advertisers.

W. H. Donohoe, 17 E. 28th St., New York.
For page see List of Advertisers.

Alex. McConnell, New York.
For page see List of Advertisers.

M. A. Bowe, 1294 Broadway, New York.
For page see List of Advertisers.

Robert G. Wilson, Fulton St. & Greene Av., Brooklyn, N. Y.
For page see List of Advertisers.

Thomas Young, Jr., 500 Fifth Ave., N. Y.
For page see List of Advertisers.

Young & Nugent, 42 W. 28th St., N. Y.
For page see List of Advertisers.

J. H. Dunlop, 96 Yonge St., Toronto, Can.
For page see List of Advertisers.

FLOWERS FOR EASTER

H. M. Robinson & Co., 15 Province St., Boston.
For page see List of Advertisers.

FLOWER POTS

W. H. Ernest, 28th and M Sta., Washington, D. C.
For page see List of Advertisers.

A. H. Hews & Co., Cambridge, Mass.
For page see List of Advertisers.

Hillinger Bros., Ft. Edward, N. Y.
For page see List of Advertisers.

Ited pots, seed pans, etc.
The Peters & Reed Pottery Co., Zanesville, O.

FUCHSIAS

Fuchstas, finest mixed, 2 in., \$2.50 per 100; rooted cuttings, \$1.00. Valley Greenhouse Co., Sewickley, Pa.

GALAX

Michigan Cut Flower Co., 38 and 40 Broadway, Detroit, Mich.
For page see List of Advertisers.

GERANIUMS

R. Vincent Jr. & Sons Co., White Marsh, Md.
New and Standard Varieties.
For page see List of Advertisers.

Geraniums, 2-in., double red, \$2.00 per 100. J. H. Dann & Son, Westfield, N. Y.

500 Nutt Geranium Cuttings, \$1.50 per 100, or the lot for \$6.50. C. W. Moeckel, 17 Summer St., Fitchburg, Mass.

GLADIOLI

Arthur Cowee, Meadowvale Farm, Berlin, New York.
For page see List of Advertisers.

J. L. Moore, Northboro, Mass.
For page see List of Advertisers.

I. & J. L. Leonard, Iona, N. J.
Gladolus Bulbs.
For page see List of Advertisers.

Gladioli. Write for leaflet. B. Hammond Tracy, Cedar Acres, Wenham, Mass.

Gladioli. Named varieties and mixtures. Send for list. E. E. Stewart, River Junction, Mich.

GLASS

Boston Plate & Window Glass Co., Boston.
For page see List of Advertisers.

Standard Plate Glass Co., 26-30 Sudbury St., Boston.
For page see List of Advertisers.

Parshelsky Bros., 59 Montrose Ave., Brooklyn, N. Y.
For page see List of Advertisers.

Metropolitan Material Co., 1398-1408 Metropolitan Ave., Brooklyn, N. Y.
For page see List of Advertisers.

S. Jacobs & Sons, 1365-79 Flushing Ave., Brooklyn, N. Y.

Foley Mfg. Co., Western Ave., between 25th & 26th Sts., Chicago.

Greenhouse glass, lowest prices. Johnston Glass Co., Hartford City, Ind.

GLASS, High Grade, Double Thick Greenhouse Glass. Lord & Burnham, 1133 Broadway, N. Y.

GLAZING POINT

H. A. Dreer, Philadelphia, Pa.
For page see List of Advertisers.

GLAZING POINTS, Lord & Burnham Special Glazing Nails (Points). Lord & Burnham, 1133 Broadway, N. Y.

GREENHOUSE BUILDING MATERIAL

Lord & Burnham Co., 1133 Broadway, New York.
For page see List of Advertisers.

Peterson U-Bar Co., 1 Madison Sq., N. Y.
For page see List of Advertisers.

A. T. Stearns Lumber Co., Neponset, Boston.
For page see List of Advertisers.

King Construction Co., N. Tonawanda, New York.
For page see List of Advertisers.

J. C. Moninger Co., 117 East Blackhawk St., Chicago, Ill.
For page see List of Advertisers.

Foley Mfg. Co., Western Ave., between 25th & 26th Sts., Chicago.
For page see List of Advertisers.

In writing to Advertisers kindly mention Horticulture

GREENHOUSE BUILDING MATERIAL - Continued

- I. Cassidy, Summer Ave. and Erie R. R., Newark, N. J.
For page see List of Advertisers.
- W. H. Lutton, Jersey City, N. J.
For page see List of Advertisers.
- Geo. B. Deane, 18 Midway St., Boston, Iron Pipe.
For page see List of Advertisers.
- Metropolitan Material Co., 1398-1408 Metropolitan Ave., Brooklyn, N. Y.
For page see List of Advertisers.
- S. Jacobs & Sons, 1365-79 Flushing Ave., Brooklyn, N. Y.

GREENHOUSE CONSTRUCTION
GREENHOUSE CONSTRUCTION, Seal Iron Greenhouse, New Truss Houses and Iron Frame Houses. Lord & Burnham, 1133 Broadway, N. Y.

J. A. Payne, 260-274 Culver Ave., Jersey City, N. J.
For page see List of Advertisers.

I. Cassidy, Summer Ave. and Erie R. R., Newark, N. J.
For page see List of Advertisers.

Foley Mfg. Co., Western Ave., between 25th & 26th Sts., Chicago.

W. H. Lutton, Jersey City, N. J.
For page see List of Advertisers.

GREENHOUSE HOSE

Mineralized Rubber Co., 18 Cliff St., N. Y.
For page see List of Advertisers.

GUTTERS

GUTTERS, Cast Iron Gutters, L. & B. Improved V Shaped Gutter with drip gutter attachment. Lord & Burnham, 1133 Broadway, N. Y.

HAIL INSURANCE

Florists' Hall Assn. of America.
J. G. Esler, Saddle River, N. J.
For page see List of Advertisers.

HARDY FERNS AND SUPPLIES

H. M. Robinson & Co., 15 Province St. and 8 Chapin Pl., Boston, Mass.
For page see List of Advertisers.

The Kervan Co., 113 W. 28th St., N. Y.
For page see List of Advertisers.

Michigan Cut Flower Exchange,
38 and 40 Broadway, Detroit, Mich.
Fancy Ferns.

For page see List of Advertisers.

H. J. Smith, Hinsdale, Mass.
For page see List of Advertisers.

HARDY PLANTS

Hardy Plants. We have one of the finest assortments of seedlings, transplanted and field-grown stock. Get our prices and descriptions. Mesback Greenhouse Co., Oanr-ga, Ill.

Lobelia cardinalis, large clumps, \$1.50 per doz., \$8.00 per 100. Gentiana Andrewsil and linearis, in clumps, \$1.50 per doz., \$8.00 per 100. Native ferns, trees and shrubs at prices to suit. A fine lot of nursery grown White Pine, Hemlock, Fir Balsam, Norway and White Spruce of various sizes at reduced prices. L. E. Williams, Nottingham, N. H.

HART'S HANDY HANDLE

Geo. B. Hart, 24 Stone St., Rochester, N. Y.
For page see List of Advertisers.

HEATING APPARATUS

Lord & Burnham Co.,
1133 Broadway, New York.
For page see List of Advertisers.

Pierson U-Bar Co., 1 Madison Sq., N. Y.
For page see List of Advertisers.

John A. Payne, 260-274 Culver Ave., Jersey City, N. J.
For page see List of Advertisers.

HELIOPTROPES.

Heliotropes, 2 in., \$2.50 100; rooted cuttings, \$1.00 100. Valley Greenhouse Co., Sewickley, Pa.

HELP FURNISHED

Thos. H. Bambrick, 34 S. 7th St., Phila.
For page see List of Advertisers.

HERBACEOUS PERENNIALS

Red Oak Nurseries, Pliskerville, R. I.
For page see List of Advertisers.

HOLLYHOCKS

Hollyhocks, separate colors, field grown, healthy stock, \$3.00 per 100; also Dahlias, novelties and standard varieties. Send for catalogue. W. W. Wilmore, Box 382, Denver, Colo.

HOSE

Frank L. Moore, Chatham, N. J.
Sunnyside Hose.
For page see List of Advertisers.

HOT-BED SASH

The A. T. Stearns Lumber Co., Neponset, Mass.
For page see List of Advertisers.

Pierson U-Bar Co., 1 Madison Sq., N. Y.
For page see List of Advertisers.

Lord & Burnham Co., 1133 Broadway, N. Y.
For page see List of Advertisers.

Foley Mfg. Co., Western Ave., between 25th & 26th Sts., Chicago.

HYDRANGEAS.

HYDRANGEAS PANICULATA.
Grandiflora, 18-in. to 24-in., \$5.00 per 100.
Grandiflora, 2 ft. to 3 ft., \$7.00 per 100.
Grandiflora, 3 ft., \$8.00 per 100.
J. H. Dann & Son, Westfield, N. Y.

INSECTICIDES.

Nicotinide kills all greenhouse pests.
P. R. Paletborpe Co.,
Eleventh St., Owensboro, Ky.
For page see List of Advertisers.

IRISES

Japan Iris (Iris Kaempferi), divided roots, 2.5 shoots, mixed, \$4.00 per 100; divided roots, 2.5 shoots, white, \$3.00 per 100. Large clumps, 10c. each. Wm. F. Halsey, Southampton, N. Y.

Iris pallida dalmatica, a beautiful shade of lavender; the largest and most beautiful of all the German Irises; perfectly hardy, and free flowering. One of the good things almost lost to horticulture. \$12.00 per 100; \$100.00 per 1,000. Cash with order. J. A. Peterson, McHenry Ave., Westwood, Cincinnati, O.

JAPANA CUT FLOWER HOLDER

M. V. Garnsey, 130 Walola Ave.,
La Grange, Ill., Dept. A.
For page see List of Advertisers.

KENTIAS

A. Lenthy & Co., Roseland, Mass.
For page see List of Advertisers.

Godfrey Aschmsan, 1012 W. Ontario St., Philadelphia.
For page see List of Advertisers.

LAWN VASES

Kramer Bros. Fdy. Co., Dayton, Ohio.
For page see List of Advertisers.

LEADING RETAIL FLORISTS

Park Floral Co., Denver, Colo.
For page see List of Advertisers.

George H. Cooke, Washington, D. C.
For page see List of Advertisers.

Gude Bros. Co., 1214 F St.,
Washington, D. C.
For page see List of Advertisers.

Atlanta Floral Co., Atlanta, Ga.
For page see List of Advertisers.

M. C. & J. E. Hauswirth, 232 Michigan Ave.,
Chicago.

For page see List of Advertisers.

William J. Smyth, Michigan Ave. and 31st St., Chicago.

For page see List of Advertisers.

Isaac Scholz, 644 4th Ave., Louisville, Ky.
For page see List of Advertisers.

Thos. F. Galvin, 124 Tremont St., Boston.
For page see List of Advertisers.

Julius A. Zinn, 2 Beacon St., Boston.
For page see List of Advertisers.

Houghton & Clark, 396 Boylston St.,
Boston.
For page see List of Advertisers.

Sidney Hoffmsn, 59-61 Massachusetts Ave.,
Boston.
For page see List of Advertisers.

Edward MacMullin, 194 Boylston St.,
Boston.
For page see List of Advertisers.

LEADING RETAIL FLORISTS - Continued

J. Breitmeyer's Sons, Detroit, Mich.
For page see List of Advertisers.

Samuel Murray, 1017 Broadway,
Kansas City, Mo.
For page see List of Advertisers.

Wm. L. Rock Flower Co., 1118 Walnut St.,
Kansas City, Mo.
For page see List of Advertisers.

Fred C. Weber, 4326 Olive St., St. Louis, Mo.
For page see List of Advertisers.

J. N. Champlon & Co., 1026 Chapel St.,
New Haven, Conn.
For page see List of Advertisers.

H. G. Eyres, 11 N. Pearl St., Albany, N. Y.
For page see List of Advertisers.

David Clarke's Sons, 2139-2141 Broadway,
New York.
For page see List of Advertisers.

W. H. Donohoe, 17 E. 28th St., New York.
For page see List of Advertisers.

Alex. McConnell, New York.
For page see List of Advertisers.

M. A. Bowe, 1294 Broadway, New York.
For page see List of Advertisers.

Robert G. Wilson, Fulton St. and Greene Ave.,
Brooklyn, N. Y.
For page see List of Advertisers.

Thomas Young, Jr., 500 Fifth Ave., N. Y.
For page see List of Advertisers.

Young & Nugent, 42 W. 28th St., N. Y.
For page see List of Advertisers.

J. H. Dunlop, 96 Yonge St., Toronto, Can.
For page see List of Advertisers.

NEW AND RARE PLANTS

Rose Hill Nurseries, New Rochelle, N. Y.
For page see List of Advertisers.

MISSION PLANT BOX

Wagner Park Conservatories, Sidney, O.
For page see List of Advertisers.

NICO-FUME

Kentucky Tobacco Product Co.,
Louisville, Ky.
For page see List of Advertisers.

NURSERY STOCK

John Waterer & Sons, Ltd.,
American Nursery, Bagshot, England.
For page see List of Advertisers.

New England Nurseries, Bedford, Mass.
Shrubs, Roses and Herbaceous Perennials.
Specimen Pyramidal Box.

For page see List of Advertisers.

Bay State Nurseries, N. Abington, Mass.
Herbaceous Perennials, Hardy Ornamental Trees.

For page see List of Advertisers.

Cleary's Horticultural Co., 62 Veasey St.,
New York.
For page see List of Advertisers.

P. Ouwkerk, 218 Jane St., Weehawken
Heights, N. J.
Holland Nursery Stock for Forcing.
For page see List of Advertisers.

American Nursery Co., 150 Broadway, New
York, N. Y.
For page see List of Advertisers.

I. & J. L. Leonard, Iona, N. J.
California Privet, American Chestnut.
For page see List of Advertisers.

L. L. May & Co., St. Paul, Minn.
Shrubs, Roses, Small Fruits, Ornamental
and Fruit Trees.
For page see List of Advertisers.

The Morris Nursery Co.,
Sales Office, 1 Madison Ave., New York.
Ornamental Trees, Evergreens, Hedge
Plants.
For page see List of Advertisers.

Peter's Nursery Co., Knoxville, Tenn.
Live Fences; Amoor and California Privet.
For page see List of Advertisers.

P. J. Berckmans Co., Fruitland Nurseries,
Augusta, Ga.
Blota Aurea Nana.

Nursery Stock Berberis Thunbergii 1
yr. seedlings, \$10 per 1000; 2 yrs., \$15 per
1000. Viburnum plicatum, \$50, \$60 and
\$80 per 1000. Ligustrum Itoya, 4 ft., \$9
per 100. Rosa Wichuraiana, 4 to 6 ft.
Lonicera Morrowii, 3 to 4 ft. Bignonia
Thunbergii and radicans. Send for list of
shrubs, large and small. Samuel C. Moon,
Morrisville, Pa.

NURSERY STOCK — Continued
NURSERY STOCK.

Per 100
2,500 Berberis Thunbergii, 2 to 3 ft., \$9.00
1,000 Cornus Spathul, golden, 1½ to 2 ft. 10.00
1,000 Cydonia Japonica, 2½ to 3 ft. 9.00
500 Dentzia Fride of Rochester. 10.00
500 Forsythia in 3 varieties. 10.00
500 Hydrangea Pan. grand. 10.00
10,000 Ligustrum Iboti, 2½ to 3 ft. 8.00
1,000 Crimson Ramblers, 2 yrs. 9.00 & 10.00
1,000 Dorothy Perkins, 2 yrs. 9.00 & 10.00
Rhododendrons, Azaleas, etc. etc.
The Continental Nurseries, Franklin, Mass.

ORCHID PLANTS

Lager & Hurrell, Summit, N. J.
For page see List of Advertisers.
Sander, St. Albans, England.
Importers, Exporters, Growers, Hybridists
For page see List of Advertisers.
Jullus Roehrs Co., Rutherford, N. J.
For page see List of Advertisers.
Carrillo & Baldwin, Secaucus, N. J.
For page see List of Advertisers.
Jos. A. Manda, 191 Valley Road, W.
Orange, N. J.
For page see List of Advertisers.
Ordonez Bros., Madison, N. J., Box 105.
For page see List of Advertisers.

PALMS

A. Leuty & Co., Perkins St. Nurseries,
Roslindale, Mass.
For page see List of Advertisers.
Robert Craig Co., Market and 49th Sts.,
Philadelphia, Pa.
For page see List of Advertisers.
Kentia, Phoenix, etc., all sizes. Write
for new price list. Jullus Roehrs Co.,
Rutherford, N. J.

PAINT AND PUTTY

PAINT AND PUTTY: Ideal Greenhouse
lead; Special Greenhouse Putty. Lord &
Burnham, 1133 Broadway, N. Y.

PANSY PLANTS.

Pansy Plants. From extra selected
seed. Fall seedlings \$3.50 per 1000. Fall
transplanted \$6.00 per 1000. Large plants
\$10.00 per 1000. Moshaek Greenhouse Co.,
Onarga, Ill.

PATENTS

Siggers & Siggers, Washington, D. C.
For page see List of Advertisers.

PEAT

Orchid peat, Rotted peat, Azalea peat,
Leaf-Mould, Live Sphagnum moss, Baled
Sphagnum moss, Green Clump moss, etc.
Jobbers' list on application. C. W. Brown
ell & Co., Walden, N. Y.

PELARGONIUMS

R. Vincent, Jr. & Sons Co., White Marsh,
Maryland.
For page see List of Advertisers.

PEONIES

Wholesale Peony list for fall 1908 is now
ready. J. F. Rosenfield, West Point, Neb.
One of the finest collections in America.
Send 25 cts. in stamps for new edition of
Peony Manual. C. S. Harrison's Select
Nursery, York, Neb.

PHLOXES

Send 25 cts. in stamps for Phlox Manual.
Fine mixed phloxes \$1.50 per 100. C. S.
Harrison's Select Nursery, York, Neb.

PIPE AND FITTINGS

Foley Mfg. Co., between Western Ave. and
26th St., Chicago, Ill.
Eagle Metal & Supply Co., Johnson and
Union Aves., Brooklyn, N. Y.
Second-Hand Pipe and Boiler Tubes.
For page see List of Advertisers.

PIPE AND FITTINGS. Cast Iron and
Wrought Pipe, Valves, Elbows, Pipe Hooks,
Automatic Air Headers, etc. Lord &
Burnham, 1133 Broadway, N. Y.

PLANT BED CLOTH

Mineralized Rubber Co., 18 Cliff St., N. Y.
For page see List of Advertisers.

PLANT DECORATIONS BY TELE-
GRAPH

George Wittbold Co., 1657 50 Buckingham
Place, Chicago.
For page see List of Advertisers.

PLANT STAKES AND TRELLISES

Seele's Patent, for roses, chrysanthemums,
gladioli, tuberose, dahlias, tomatoes,
egg plants, etc. H. D. Seele & Sons,
Manuf., Elkhart, Ind.

PLANT TUBS

Henry A. Dreef, 714 Chestnut St., Phila.
Keystone Cedar.

POT HANGERS

Pot hangers, Kramer's \$1 doz. by exp.,
\$1.25 by mail. I. N. Kramer & Son, Cedar
Rapids, Ia.

PRIVET

1000 Ligustrum Iboti, 4 ft.; 500 Ligu-
strum vulgaris, 2 to 4 ft.; 1000 Ligu-
strum chinensis, 3 ft., light, \$10 per 1000.
Send for list of large and small shrubs,
Samuel C. Moon, Morrisville, Pa.

RAFFIA

Raffia (colored), 20 beautiful shades
Samples free. R. H. Comey Co., Camden,
N. J.; 810 Washburn Ave., Chicago, Ill.

RHODODENDRONS

John Waterer & Sons, Ltd.,
American Nursery, Bagshot, England.
For page see List of Advertisers.
P. Ouwkerk, Hoboken, N. J.
For page see List of Advertisers.

ROSES

Jullus Roehrs Co., Rutherford, N. J.
Rambler Rose, Newport Fairy.
For page see List of Advertisers.
New England Nurseries, Inc., Bedford,
Mass.
For page see List of Advertisers.
Ray State Nurseries, N. Abington, Mass.
For page see List of Advertisers.
Robert Craig Co., Market and 49th Sts.,
Philadelphia, Pa.
For page see List of Advertisers.
Dingee-Conard Co., West Grove, Pa.
New Climbing Rose, Tausendsebon.
For page see List of Advertisers.

The Morris Nursery Co.,
Sales Office, 1 Madison Ave., New York.
Ornamental Trees, Evergreens, Hedge
Plants.
For page see List of Advertisers.

Montrose Greenhouses, Montrose, Mass.
Grafted Stock Bride, Bridesmaid, Killar-
ney.
For page see List of Advertisers.

F. R. Pierson Co., Tarrytown-on-Hudson,
N. Y.
Hardy Roses for the Garden.
For page see List of Advertisers.

R. & J. Farquhar & Co.,
6 and 7 South Market Street, Boston.
For page see List of Advertisers.

The E. G. Hill Co., Richmond, Ind.
Roses, Blue Red, American Beauty.
For page see List of Advertisers.

Poehlmann Bros. Co., Morton Grove, Ill.
Roses That Win.
For page see List of Advertisers.

Ehwanger & Barry, Rochester, N. Y.
Hardy Roses.

400 varieties; own roots; summer grown.
Ledde Company, Springfield, Ohio.

Roses, Maid, Bride, Chateauf, Gate, 2
in., \$3.00 100. Valley Greenhouse Co., Se-
wickley, Pa.

Crimson Ramblers, 2 year, on own roots,
extra strong, at 7 cents. Gilbert Costich,
Rochester, N. Y.

Low-budded roses, No. 1, \$95.00; No.
1, 2, \$65.00 1000. H. T. Jones, Elizabeth,
N. J.

SAGE PLANTS

Good thrifty sage plants from 2-inch pots,
\$1.50 per 100; ready now. Cash with order.
Virginia Nursery Co., Purcellville Va.

SEEDS

T. J. Grey Co., 32 So. Market St.,
Boston, Mass.
For page see List of Advertisers.
Joseph Breck & Sons,
51 and 52 N. Market St., Boston, Mass.
For page see List of Advertisers.
W. Atlee Burpee & Co., Philadelphia.
For page see List of Advertisers
J. M. Thorburn & Co., 33 Barclay St., N. Y.
For page see List of Advertisers.
A. T. Boddington, 342 W. 14th St., N. Y.
For page see List of Advertisers.
H. F. Micbell Co., 1017 Market St., Phila.
For page see List of Advertisers.
James Vick's Sons, Rochester, N. Y.
Vick's Superb Pansy Seed.
For page see List of Advertisers.
Hjalmar Hartmann & Co.,
12 Stormgade, Copenhagen, Denmark.
Cauliflower and Cabbage Seed.
For page see List of Advertisers
Rickards Bros., 37 E. 19 th St., New York.
For page see List of Advertisers.
R. & J. Farquhar & Co., 6-7 So. Market
St., Boston.
For page see List of Advertisers.
C. C. Morse & Co., 48-56 Jackson St.,
San Francisco, Cal.
For page see List of Advertisers.
H. E. Fliske Seed Co., Fanenil Hall Sq.,
Boston.
Aster Seed.
For page see List of Advertisers.
Branlan Seed Growers Co., San Jose, Cal.
For page see List of Advertisers.
O. V. Zangen, Hoboken, N. J.
For page see List of Advertisers.
Stumpp & Walter Co., 50 Barclay St.,
New York.
For page see List of Advertisers.
Weeber & Don, 114 Chambers St.,
New York.
For page see List of Advertisers.
Altimo Culture Co., Canfield, O.
Aster Seed.
For page see List of Advertisers.
Asparagus Pl. Namus, \$2.50 per 1000.
Plant early. Asparagus Plants 14 to 18
inches high, \$6 per 100. Peter Mack, Box
172, Orlando, Fla.
Davis Perfect and Burrell's Klondike
Cucumber Seed, 85c. per pound. Finest
slicing varieties grown. D. V. Burrell,
Rocky Ford, Colorado.

SEEDS SEEDS SEEDS
Buckee's Famous "Full of Life" Pea-
green Strains of the newest and best varie-
ties vegetable and flower seeds, etc. If
you have failed to receive a copy of our
Spring Trade List write for it today.
H. W. BUCKBEE,
Rockford, Illinois, Rockford Seed Farms,
Forest City Greenhouses.
Elmer D. Smith & Co., Adrian, Mich.
Aster Seeds.
For page see List of Advertisers.

SMILAX
E. A. Beaven, Evergreen, Ala.
Southern Wild Smilax; Log Mossea.
For page see List of Advertisers.
Smilax, nice young plants, fall sown, 50c.
per 100; \$4.00 per 1000. F. A. Baller,
Bloomington, Ill.

SPHAGNUM MOSS
Live Sphagnum moss, orchid peat and
orchid baskets always on hand. Lager &
Hurrell, Summit, N. I.
Fresh, clean, 5 bbl. bale, \$1.25; 2 bales,
\$2.25; 5 bales, \$5.00; 10 bales, \$9.50. Cash.
H. R. Akers, Chatsworth, N. J.
For a high grade Sphagnum and Green
Decorating Moss, different grades of Peat,
write for prices and samples. We can give
best satisfaction as our stock is well
cleaned, well packed. Prompt attention
given. American Moss & Peat Co., Box 6,
Waretown, N. J.

In writing to Advertisers kindly mention Horticulture

SPRAYERS

Charles J. Jager Co., 281-85 Franklin St., Boston.
For page see List of Advertisers.

SQUABS

Jno. A. Kepner, Harrisburg, Pa., Box 3.
For page see List of Advertisers.

STRAWBERRY PLANTS

Strawberry plants and Asparagus roots (50 varieties). Catalog free. C. Pelree, Dighton, Mass.

STEAM TRAP

E. Hippard, Youngstown, O.
For page see List of Advertisers.

VEGETABLE PLANTS

Horse radish sets. Extra fine stock, \$2.50, \$3.50, \$4.50 per 100. Mosbaek Greenhouse Co., Onarga, Ill.

VENTILATING APPARATUS

Pierson U-Bar Co., 1 Madison Sq., N. Y.
For page see List of Advertisers.

Foley Mfg. Co., Western Ave., between 25th & 26th Sts., Chicago.
For page see List of Advertisers.

John A. Payne, 260-274 Culver Ave., Jersey City, N. J.
For page see List of Advertisers.

The Advance Co., Richmond, Ind.
For page see List of Advertisers.

VENTILATING MACHINERY. New Model enclosed, self-oiling gear; Standard Model Open Gear. Lord & Burnham, 1133 Broadway, N. Y.

VINCAS

J. J. Arnold, Homer, N. Y.

VIOLETS

William Sim, Cliftondale, Mass.
Violet Boston.
For page see List of Advertisers.

Princess of Wales Violet Chimps, \$5.00 per 100. Joy Floral Company, Nashville, Tenn.

Violet cuttings, "Maria Louisa" Rhinebeck stock, rooted runners. May delivery \$20.00 M. Wm. F. Kasting Co., 383 Ellicott St., Buffalo, N. Y.

WEEKLY BOARD FILE

A. F. Lewis Mfg. Co., E. Boston, Mass.
For page see List of Advertisers.

WIREWORK

Reed & Keller, 122 W. 25th St., N. Y.
For page see List of Advertisers.

Wirework. Write for our catalogue. Holton & Hunkel Co., Milwaukee, Wis.

William E. Hellscher's Wire Works, 28-40 Broadway, Detroit, Mich.

The "Just Right" kind. Send for price list. Frank W. Ball, 31 East Third Street, Cincinnati, O.

WOOD MOSS

D. Rusconi, 128 W. 6th St., Cincinnati, O.
For page see List of Advertisers.

WHOLESALE FLORISTS**Boston**

N. F. McCarthy & Co., 84 Hawley St., Boston.
For page see List of Advertisers.

H. M. Robinson & Co., 15 Province St. and 9 Chapman Pl., Boston.
For page see List of Advertisers.

Welch Bros., 226 Devonshire St., Boston.
For page see List of Advertisers.

Buffalo

Wm. F. Kasting Co., 383-87 Ellicott St., Buffalo, N. Y.
For page see List of Advertisers.

Chicago

Chas. W. McKellar, 51 Wabash Ave., Chicago.
For page see List of Advertisers.

Peter Reinberg, 51 Wabash Ave., Chicago.
For page see List of Advertisers.

E. F. Winterson Co., 45-49 Wabash Ave., Chicago.
For page see List of Advertisers.

WHOLESALE FLORISTS—**Continued****Detroit**

Michigan Cut Flower Exchange, 38 and 40 Broadway, Detroit, Mich.
For page see List of Advertisers.

Minneapolis

Rice Bros., 115 N. 6th St., Minneapolis, Minn.
For page see List of Advertisers.

New York

J. K. Allen, 106 W. 28th St., New York
For page see List of Advertisers.

I. S. Fenrich, 110 W. 28th St., New York
For page see List of Advertisers.

Ford Bros., 48 W. 25th St., New York
For page see List of Advertisers.

H. E. Froment, 57 W. 28th St., New York
For page see List of Advertisers.

Alex. J. Guttman, 43 W. 28th St., New York.
For page see List of Advertisers.

E. C. Horan, 55 W. 28th St., New York
For page see List of Advertisers.

A. H. Langjahr, 55 W. 28th St., New York
For page see List of Advertisers.

James McManus, 42 W. 28th St., New York
For page see List of Advertisers.

John I. Raynor, 49 W. 28th St., New York
For page see List of Advertisers.

W. F. Sheridan, 39 W. 28th St., New York
For page see List of Advertisers.

Traendly & Scheuck, 44 W. 28th St., New York.
For page see List of Advertisers.

John Young, 51 W. 28th St., New York.
For page see List of Advertisers.

Moore, Hentz & Nash, 55 and 57 W. 26th St., New York.
For page see List of Advertisers.

Frank S. Hicks & Co., 52 W. 25th St., New York.
For page see List of Advertisers.

Frank Millang, 57 W. 26th St., New York
For page see List of Advertisers.

Wm. H. Kuebler, 28 Willoughby St., Brooklyn, N. Y.
For page see List of Advertisers.

Phillip F. Kessler, 55 and 57 W. 26th St., New York.
For page see List of Advertisers.

A. Moltz, 55-57 W. 26th St., New York.
For page see List of Advertisers.

B. S. Sloan, Jr., 55 W. 26th St., New York.
For page see List of Advertisers.

Millang Bros., 41 W. 28th St., New York.
For page see List of Advertisers.

Philadelphia

W. E. McKissick, 1619-1621 Ranstead St., Philadelphia, Pa.
For page see List of Advertisers.

Leo Nissen Co., 1209 Arch St., Philadelphia, Pa.
For page see List of Advertisers.

The S. S. Pennock-Meehan Co., 1608-18 Ludlow St., Philadelphia, Pa.
For page see List of Advertisers.

Edward Reid, 1526 Ranstead St., Philadelphia, Pa.
For page see List of Advertisers.

Pittsburg

J. B. Murdoch & Co., 714 Penn Ave., Pittsburg, Pa.
For page see List of Advertisers.

San Francisco

Alex. Mann, Jr., Co., 1125 Polk St., San Francisco, Cal.
For page see List of Advertisers.

St. Louis

H. G. Berning, 1402 Pine St., St. Louis, Mo.
For page see List of Advertisers.

WHOLESALE PLANTSMAN

Samuel A. Woodrow, 53 W. 30th St., New York.
For page see List of Advertisers.

New Offers in This Issue.

ASPARAGUS PL. NANUS AND ROBUSTUS: JAPAN LILIES: IRIS.

J. M. Thorburn & Co., 33 Barclay St., New York.
For page see List of Advertisers.

ASPARAGUS ROOTS.

D. Landreth Seed Co., Bristol, Pa.
For page see List of Advertisers.

ASPARAGUS PL. NANUS AND SPRENGERI.

Henry F. Michell Co., Philadelphia.
For page see List of Advertisers.

ASTER SEED.

Elmer D. Smith & Co., Adrian, Mich.
For page see List of Advertisers.

BEGONIAS, GLOIRE DE LORRAINE.

Thomas Roland, Nahant, Mass.
For page see List of Advertisers.

DAILY PLANT AUCTIONS.

Fruit Auction Co., Franklin and Washing Sts., New York.
For page see List of Advertisers.

EASTER FLOWERING PLANTS.

Anton Schnitthels, College Point, N. Y.
For page see List of Advertisers.

EASTER FLOWERS.

Alex. J. Guttman, 43 W. 28th St., New York.
For page see List of Advertisers.

EASTER FLOWERS.

E. C. Horan, 55 W. 28th St., New York.
For page see List of Advertisers.

EASTER FLOWERS.

Ford Bros., 48 W. 28th St., New York.
For page see List of Advertisers.

EASTER FLOWERS.

John I. Raynor, 49 W. 28th St., New York.
For page see List of Advertisers.

EASTER FLOWERS.

John Young, 51 W. 28th St., New York.
For page see List of Advertisers.

EASTER FLOWERS.

Peter Reinberg, 51 Wabash Ave., Chicago.
For page see List of Advertisers.

EASTER FLOWERS, EASTER NOVELTIES.

E. F. Winterson Co., 45, 47, 49 Wabash Ave., Chicago.
For page see List of Advertisers.

EASTER FLOWERS, NOVELTIES IN ROSES, ETC.

Traendly & Schenck, 44 W. 28th St., New York.
For page see List of Advertisers.

EASTER LILIES.

Miami Floral Co., Dayton, O.
For page see List of Advertisers.

EASTER ORCHIDS, GARDENIAS, DAISIES.

James McManus, 42 W. 28th St., New York.
For page see List of Advertisers.

EASTER PLANT AND FLOWER SHIPMENTS.

Welch Bros., 226 Devonshire St., Boston.
For page see List of Advertisers.

EASTER PLANTS.

A. Lenthly, Roslindale, Mass.
For page see List of Advertisers.

EASTER PLANTS.

S. A. Woodrow, 53 W. 30th St., New York.
For page see List of Advertisers.

ECONOMY IN HEATING.

The Castle Co., 170 Summer St., Boston.
For page see List of Advertisers.

Tobacco Paper "NICO-FUME" **LIQUID**
 IS THE **STRONGEST,**
BEST PACKED,
EASIEST APPLIED.
Furnishes the
Most Nicotine for the Money!
 ... Manufactured by ...
THE KENTUCKY TOBACCO PRODUCT CO., Louisville, Ky.

OVER 40% NICOTINE
 By far the **CHEAPEST.**
JUST NOTE PRICES!
 Pint.....\$ 1.50
 1/2 Gallon..... 5.50
 Gallon..... 10.50
 5 Gallons..... 47.25

24 sheets.....	\$ 0.75
144 sheets.....	3.50
288 sheets.....	6.50
1728 sheets.....	35.10

NEW OFFERS—Continued

FORESTRY AND ORNAMENTAL PLANTING.

Jackson's Nurseries, Portland, Me.
 For page see List of Advertisers.

HARDY FERNS: GALAX: WILD SMILAX.

Crowl Fern Co., Milington, Mass.
 For page see List of Advertisers.

HOSE.

J. G. & A. Esler, Saddle River, N. J.
 For page see List of Advertisers.

IMPROVED ECONOMY BRACKET.

Buxton & Allard, Nashua, N. H.
 For page see List of Advertisers.

IMPROVED PIPE COUPLING.

The Advance Co., Richmond, Ind.
 For page see List of Advertisers.

LILIES FOR YOU.

N. F. McCarthy & Co., 84 Hawley St., Boston.
 For page see List of Advertisers.

LONG-STEMMED LILIES, CALLAS, ETC.

Phil. F. Kessler, 55 and 57 W. 26th St., New York.
 For page see List of Advertisers.

MASTICA.

F. O. Pierce Co., 12 W. Broadway, New York.
 For page see List of Advertisers.

ONION SEED.

Bloomsdale Seed Farms, Bristol, Pa.
 For page see List of Advertisers.

ORCHIDS, ESTABLISHED, SEMI-ESTABLISHED.

Julius Roehrs Co., Rutherford, N. J.
 For page see List of Advertisers.

RED LETTER SALE.

H. E. Froment, 57 W. 28th St., New York.
 For page see List of Advertisers.

ROSES.

Elizabeth Nursery Co., Elizabeth, N. J.
 For page see List of Advertisers.

ROSES: BEGONIA GLOIRE DE LORRAINE.

Charles H. Totty, Madison, N. J.
 For page see List of Advertisers.

ROSES FOR DECORATION DAY. STANDARD AND CLIMBING ROSES, SPRING SPECIAL-TIES.

A. T. Boddington, 242 W. 14th St., New York.
 For page see List of Advertisers.

SEEDS: AGERATUM MEXICANUM BLUE STAR: LOBELIA ERINUS PENDICULATA.

O. V. Zangon, Hoboken, N. J.
 For page see List of Advertisers.

SHEEP MANURE.

Henry A. Dreer, 714 Chestnut St., Philadelphia.
 For page see List of Advertisers.

We Still Sell that GOOD HOSE

For prices address
J.G. & A. Esler
 SADDLE RIVER, N. J.

NEW OFFERS—Continued

STRAWBERRY PLANTS, THE DICKY.

C. S. Pratt, Reading, Mass.
 For page see List of Advertisers.

SURPLUS JAPAN LILIES.

Yokohama Nursery Co., 31 Barclay St., New York.
 For page see List of Advertisers.

20TH CENTURY VENTILATING ARM.

Quaker City Machine Co., Richmond, Ind.
 For page see List of Advertisers.

WHOLESALE FLORIST.

J. A. Budlong, 37-39 Randolph St., Chicago.
 For page see List of Advertisers.

WITTBOLD WATERING SYSTEM.

E. H. Hunt, 76-78 Wabash Ave., Chicago.
 For page see List of Advertisers.



The Best Bug Killer and Bloom Saver

For **PROOF**
 Write to

P. R. Palethorpe Co.
 OWENSBORO, KY.



Cattle Manure In Bags Shredded or Pulverized

Best and safest manure for florists and greenhouse use, absolutely pure, no waste, no danger. Write for circulars and prices.

The Pulverized Manure Co.,
 31 Union Stock Yards, Chicago

SQUABS

Every man should have at least 10 to 20 pair of the celebrated Plymouth Rock Homer Pigeons or their own Squab raising. It pays and is a pleasure besides. Write the undersigned for prices on mated birds.

THE BEST IN THE WORLD

Jno. A. Kepner, Box 3, Harrisburg, Pa.

SUNNYWOODS HOSE

Used and recommended by

Sunnywoods Greenhouses

See page 394 of March 21st
HORTICULTURE

OR ADDRESS

FRANK L. MOORE
 CHATHAM, NEW JERSEY

ANCHOR GREENHOUSE HOSE

WEARS WELL.

PLANT BED CLOTH

Protects from Cold and Dampness.

MINERALIZED RUBBER CO.

18 Cliff Street, New York



JAGER SPRAYERS

are money makers and money savers because they enable you to do the work right, with little labor and without wasting solution. We make an outfit for every need, from large Power Sprayers to small Hand Sprayers—each the best of its kind. **Special Sprayer Book Free**, illustrating and describing our complete line. Investigation pays.
 Chas. J. Jager Co., 251-3 Franklin St., Boston, Mass.
 Branch: 33 Canal St., Providence, R. I.

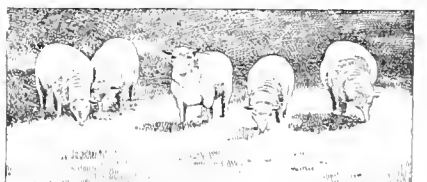

DREER'S SHEEP MANURE

WIZARD BRAND
 100 lbs. \$1.75, 500 lbs. \$8.00
 SPECIALTIES 1,000 lbs. \$15.00, 2,000 lbs. \$28.00
HENRY A. DREER, 714 Chestnut St., Phila., Pa.

List of Advertisers

Advance, The Co. 517	Lager & Hurrell 491
Auen J. S. 508	Landreit H. Seed Co. 477
Altom Culture Co. 485	Langhart, Alfred H. 508
American Nursery Co. 479	Leonard J. & J. 467
American Nursery Co. 479	Leuthy A. & Co. 471
Aschmann G. 451	Lewis A. F. Mfg. Co. 504
Atlanta Floral Co. 503	Lord & Burham Co. 520
Bambrick Thos. H. 511	Lutton W. H. 518
Barrows H. H. & Son 491	Manda Jos. A. 491
Baur Floral Co. 491	Mann, Alex. Jr. Co. 506
Bayersdorfer H. & Co. 502	MacMullin F. A. 503
Bay State Nurseries 458	May L. L. & Co. 485
Beaven E. A. 508	McCarthy N. F. & Co. 509
Bernard H. G. 500	McConnell Alex. 503
Bloodsdaile Seed Farms. 483	McKellar Charles W. 506
Boddington A. T. 489	McKissick, W. E. 506
Boston Florist Letter Co. 504	McManus Jas. 493
Boston Plate and Window Glass Co. 517	Metropolitan Material Co. 518
Rosch, Felix. 490	Miami Floral Co. 490
Bostrum-Erudy Mfg. Co. 507	Michell H. F. Co. 488
Bowe, M. A. 503	Michigan Cut Flower Exchange. 509
Braslaw Seed Growers Co. 489	Milling Bros. 509
Breck Joseph & Sons 480	Milling Frank. 509
Breitmeier's J. Sons. 502	Mineralized Rubber Co. 515
Bremond Marital. 490	Moltz, A. 509
Bridgeman's Seed Warehouse. 489	Moninger J. C. 518
Budlong J. A. 500	Montrose Green-houses. 469
Burpee W. A. & Co. 505	Moore Frank L. 509
Buxton & Allard. 505	Moore, Hentz & Nash. 509
Carrillo & Baldwin. 491	Moore, J. L. 487
Cassidy I. 518	Morris Nursery Co. 469
Castle Co. 519	Morse C. C. & Co. 489
Champion J. N. & Co. 503	Murdoch J. B. & Co. 506
Chicago Caratona Co. 467	Murray Samuel. 502
Clarke's David, Sons. 503	New England Nurseries. 469
Cleary's Horticultural Co. 503	Niessco Leo Co. 507
Coard & Jones Co. 467	Ordonez Bros. 491
Cooke G. H. 502	Ouwkerk P. R. Co. 513
Covee A. 467	Palethorpe P. R. Co. 513
Craig, Robt. Co. 460	Park Floral Co. 502
Crowl Fern Co. 504	Parshelsky Bros. 517
Dingee & Conard Co. 490	Payler Thos. 505
Doane Geo. B. & Son 518	Payne John A. 517
Doohoe W. H. 502	Pennock-Meehan Co. 506
Dorfer F. Sons & Co. 467	Perkins St Nurseries. 470
Dreer H. A. 487	Peter's Nursery Co. 469
Dunlop John H. 503	Pierce F. O. Co. 517
Dysart R. J. 504	Pierston, A. N. 407
Eagle Metal & Supply Co. 518	Pierston F. R. Co. 408
Edgar, W. W. Co. 507	Pierston U Bar Co. 519
Edwards Folding Box Co. 505	Pehlmann Bros. Co. 468
Elliott Wm. & Sons. 486	Pollworth C. C. Co. 505
Elizabeth Nurseries. 460	Pratt C. S. 487
Esler J. G. 517	Pulverized Maure Co. 515
Esler J. G. & A. 515	Quaker City Machine Co. 517
Ernest W. H. 517	Raynor John L. 408
Eyres. 503	Red Oak Nurseries. 407
Farquhar R. & J. & Co. 468	Reed & Keller. 509
Fearlich J. S. 508	Reid Edw. 516
Fiske, H. E. Seed Co. 489	Reinberg Peter. 501
Foley Mfg. Co. 518	Reuter S. J. & Sons. 516
Ford Bros. 497	Rice Bros. 506
Froment H. E. 497	Rickards Bros. 489
Fruit Auction Co. 486	Robinson H. M. & Co. 500
Galvin Thos. F. 503	Rock Wm. L. Flo. Co. 502
Garnsey M. V. 504	Roehrs Julius Co. 468
Grey T. J. Co. 480	Roland, Thomas. 490
Gude Bros. Co. 502	Rolker August & Sons. 467
Guttman Alex. J. 501	Rose Hill Nurseries. 479
Haerens A. 467	Rusconi D. 491
Hall Asso. 517	Saunders & Son. 491
Haines, J. E. 467	Schultheis Anton. 470
Hallock V. H. & Sons. 490	Schulz Jacob. 501
Hart, Geo. B. 505	Scott, John. 491
Hartmann Hjalmar & Co. 489	Sheridan W. F. 508
Hauswirth M. C. & J. E. 502	Shurtleff J. B. & Son. 467
Herbert David & Son. 487	Siggers & Siggers. 517
Hews A. H. & Co. 517	Sim, Wm. 467
Hicks Frank S. & Co. 517	Situations & Wants. 516
Hilfinger Bros. 517	Skidelsky S. S. 467
Hill, The E. G. Co. 468	Slinn B. S. Jr. 508
Hippard F. 518	Smith Elmer Co. 483
Hoffman. 502	Smith H. J. 506
Horan E. C. 501	Smyth Wm. J. 502
Houghton & Clark. 501	Standard Plate Glass Co. 517
Hunt E. H. 484	Stevens A. T. Lumber Co. 517
Jackson Nurseries. 468	Stump & Walter Co. 467
Lager, Chas. J. Co. 515	Sunnywood Green-houses. 515
Kasung W. F. 504	Thorburn J. M. & Co. 490
Kentucky Tobacco Product Co. 511	Totty Chas. H. 485
Kepner J. A. 511	Traendly & Schenck. 494
Kervan Co., The. 477	Valentine, J. A. 502
Kessler, P. F. 451	Velthuis K. 410
King Cons. Co. 511	Vick's Jas. Sons. 429
Koral Mfg. Co. 504	Vincent R. Jr. & Sons. 467
Kramer Bros. Fldy Co. 511	
Kuebler Wm. H. 501	

Wagner Park Conservatories. 504	Wittbold Geo. Co. 503
Ward R. M. & Co. 490	Woodrow, Sam'l A. 509
Water John & Sons. 467	Yokohama Nursery Co. 470
Weber F. C. 502	Young John. 491
Weber & Don. 489	Young, Thos. Jr. 503
Welch Bros. 494	Young & Nugent. 503
Wilson. 503	Zangen O. V. 489
Winterson, E. F. Co. 506	Zinn J. A. 503

THE GLASS MARKET.

It appears that growers as a rule know a good thing when they see it, as is evidenced by their eagerness to take advantage of the extremely low prices of glass this year. Notwithstanding the hard season most growers have experienced, we find the demand for greenhouse glass far above normal. This proves beyond question that growers are simply investing their money in glass, knowing prices this year to be lower than for several years past, it being a fact that some have bought who will not erect new houses until 1909.

This excessive demand, especially for 16x24 Double, is having its natural effect in a stiffening of prices at the factories which shut down for the summer months usually in May; and while jobbers' prices have not changed as yet, there is a strong inclination towards an advance in the near future.

GREENHOUSES BUILDING OR CONTEMPLATED.

- Middlebury, Vt.—Page F. Potter, one house.
- Ottawa, Ont.—R. H. Wright, one house.
- Hannibal, Mo.—E. A. Hodge, one house.
- Brampton, Ont.—Wm. Fendley, one house.
- Denison, Tex.—E. Farley, range of houses.
- Montreal, Can.—E. L. Pease, range of houses.
- Hollis, N. H.—George F. Hills, vegetable houses.
- Sheboygan, Wis.—J. E. Matthewson, range of houses.
- Far Rockaway, N. Y.—I. F. Iseberg, conservatory.
- Leetsdale, Pa.—W. Rosenbauer, two houses, each 18 x 112.
- N. Middleboro, Mass.—Miss A. B. Jenks, improvements.
- Philadelphia, Pa.—C. Eisele, six houses, each 18 x 60.
- Austin, Minn.—A. N. Kinsman, two houses each 30 x 200.
- Kennett, Pa.—J. B. Swayne, four houses, each 28 x 200.
- So. Manchester, Conn.—Seth L. Cheney, house, 10 x 200.
- Mt. Sterling, Ky.—Mt. Sterling Floral Co., house, 40 x 75.
- Nashville, Tenn.—Joy Floral Co., two rose houses, each 30 x 100.
- Newton Centre, Mass.—F. E. Palmer, two houses, each 35 x 150.
- So. Bend, Ind.—J. M. Studenaker, palm house, 26 x 50; house, 22 x 100.
- New Orleans, La.—J. E. Dubois, three houses, 11 x 100, 12 x 35, 18 x 100.
- F. Toronto, Ont.—T. H. P. Hammett, one house; Joseph Boston, one house.
- London, Ont. Mt. Pleasant Cemetery, one house; Asylum for Insane, one house.
- Toledo, O.—Krieger Bros., two carnation houses, 30 x 250, 36 x 250, and boiler house.

HELP WANTED

WANTED — SALESMAN

To Handle Good Side Line On Commission

One who calls on Florists, Seed Houses, Nurseries, Cemetery Superintendents, Monument Dealers, etc.

The Kramer Bros. Foundry Co. DAYTON, OHIO

WANTED

A competent man for designing and packing room to take full charge. Must be a first-class workman on tunnel work and be thoroughly experienced in the retail cutflower line. Also one experienced on pot plants and design work. Good situations for the right men. Apply with references.

S. J. REUTER & SON., Inc. Westerly, R. I.

FOREMAN WANTED

A man with good experience in Roses and Carnations to take charge of a commercial establishment growing for the wholesale trade.

W. J. DANA

Wellesley Hills, Massachusetts

WANTED—A good all around man for greenhouse work and one who has a good knowledge of palms, azaleas, etc. State experience and wages desired. Address Palmus, care of HORTICULTURE.

SITUATIONS WANTED

GOOD MEN

When you need good men, skilled or unskilled, Write:

THOS. H. BAMBRICK

34 South 7th Street Philadelphia

Help of all kinds, including that for Florists, Nurserymen, Seedsmen and the Horticultural trade generally.

SITUATION WANTED in general greenhouse work; single, age 35, five years' experience, commercial. Address W. W., care HORTICULTURE.

FOR SALE

FOR SALE—A large consignment of 16x24 double thick American glass, A and B quality. For further information write Parshelsky Brothers, 59 Montrose Avenue, Brooklyn, N. Y.

FOR RENT.

FOR RENT—Six greenhouses, three acres fine soil, for term of years. Cheap. Address William Harris, Arlington, N. J.

MISCELLANEOUS WANTS

WANTED to lease with privilege of buying a few small greenhouses with about ten acres rich tillable land suitable for growing nursery stock, asters, etc., in good retail district; state rent, size of houses, city water, railway facilities, etc. Address Landscape, Fairfield, Conn.

GREENHOUSE GLASS

Cheaper Now Than For Years

We are taking contracts for next Spring delivery.

WRITE FOR OUR PRICES

STANDARD PLATE GLASS COMPANY

26-30 Sudbury St. 61-63 Portland St.
BOSTON, MASS.

GLASS

Greenhouse and Hot Bed

SIZES OUR SPECIALTY IMMENSE STOCK

Plate and Window Glass

Write us for Our Prices.

PARSHELSKY BROS.

59 Montrose Ave., BROOKLYN, N. Y.



STANDARD FLOWER POTS

Packed in small crates, easy to handle.

Price per crate	Price per crate	
1500 2 in. pots in crate \$4.88	120 7 in. pots in crate \$4.20	
1500 2 1/2 " " " 5.25	60 8 " " " 3.00	
1500 3 " " " 6.00	HAND MADE	
1000 3 " " " 5.00	48 9 in. pots in crate \$3.60	
800 3 1/2 " " " 5.80	48 10 " " " 4.80	
500 4 " " " 4.50	24 11 " " " 3.60	
320 5 " " " 4.51	24 12 " " " 4.80	
144 6 " " " 3.16	12 14 " " " 4.80	
	6 16 " " " 4.50	

Seed pans, same price as pots. Send for price list of Cylinders for Cut flowers, Hanging Baskets, Lawn Vases, etc. Ten per cent. off for cash with order. Address **Hilfinger Bros., Pottery, Fort Edward, N. Y.** August Rolker & Sons, Agts., 31 Barclay St., N. Y. City.

John A. Payne

Greenhouse Designer and Builder
260-274 Culver Ave., Jersey City, N. J.
Purlin



Pipe Tee

The PAYNE "Grip-tight Fitting"

for purlins and columns, is the strongest and most secure fitting yet produced for this purpose, because it is held fast by two bolts where the greatest grip is required. They cannot break because the bolts are close to edge of pipe.

Iron and Wood Frame Greenhouses of every type. Material only or erected.

Let us estimate on your requirements.

Column

Everything for the Greenhouse

LOOK

For a most

SENSATIONAL

Advertisement in regard to

Economical Heating

In Next Issue



Evans 20th Century Arm

Will not twist your shafting pipe. Give it a trial and you will use no other. Three times the power of elbow arms.

Write for Catalogue

QUAKER CITY MACHINE CO. Richmond, Ind.

Standard Flower POTS

If your greenhouses are within 500 miles of the Capitol, write us, we can save you money

W. H. ERNEST

28th and M Street WASHINGTON D. C.

CYPRESS SASH BARS

82 feet or longer
HOT BED SASH
PECKY CYPRESS BENCH LUMBER

GREENHOUSES

ERECTED AND EQUIPPED COMPLETE IF DESIRED

Write for Circular "D" and Prices

The A. T. STEARNS LUMBER CO.
NEPONSET, BOSTON, MASS.

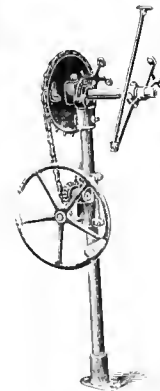

The Advance Ventilating Apparatus

is in use in 38 states. Has pleased all of our customers. Write us about our **New Pipe Coupling** Line shafting can be easily and firmly fastened together by the use of a monkey wrench only. Shafting pipe at regular prices with this coupling. Give us a chance to figure on your needs.

The Advance Co.
RICHMOND, IND.

Look at List of NEW OFFERS
Pages 514-515

PATENTS

Trademarks and Copyrights

Send your business direct to Washington. Saves time and insures better service. Personal attention guaranteed. Twenty-five years' active service. SPECIALTY: "Working on the Failure of Others."

SIGGERS & SIGGERS

PATENT LAWYERS

Box 9, National Union Building
Washington, D. C.

MASTICA
FOR Greenhouse Glazing
USE IT NOW.
F. O. PIERCE CO.
12 W. Broadway and
227 Greenwich St.
NEW YORK

The FLORISTS' HAIL ASSOCIATION OF AMERICA, insurer of 28,000,000 sq. ft. of glass. For particulars address **John C. Esler, Sec'y, Saddle River, N. J.**

BOSTON PLATE & WINDOW GLASS COMPANY

GREENHOUSE GLASS --- German and American

261 to 287 A Street

BOSTON

20-22 Canal Street

WILLIAM H. LUTTON

HORTICULTURAL ARCHITECT AND BUILDER

WEST SIDE AVENUE STATION (C. R. R. OF N. J.)
JERSEY CITY, N. J.

Have not been established 50 years, but long enough to convince the wide-awake Florist and Gardener that it is to his interest to place his work in thoroughly practical hands.

(150,000 sq. ft. glass erected in 1907 will substantiate this claim)

And why not? My material is the best that can be secured. My iron frame construction has every modern feature that years of practical experience can embody.

AND THEN THERE IS THE COST TO BE CONSIDERED.

Why not let us take up this important question now?

IRON PIPE

SECOND HAND

WROUGHT IRON PIPE, for Steam, Water, Gas or Oil, Fences or Posts. All Sizes. Price Low.

GEO. B. DOANE & SON
18 Midway Street, BOSTON
Telephone, Main 4419

ISAAC CASSIDY

Summer Ave. & Erie R.R., Newark, N. J.

Write for Prices

**GREENHOUSE MATERIAL
CONSTRUCTION FITTINGS**

Bench Fittings

Material Furnished and Erected

R. TOMAWANDA
N. Y.

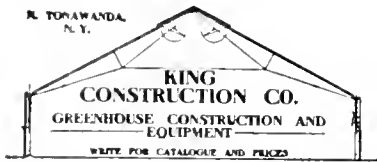

**GREENHOUSE CONSTRUCTION
LUMBER**

John C. Moninger Co.
117 E. Blackhawk St., CHICAGO

Holds Glass Firmly
See the Point of
PEERLESS

FULL SIZE
No. 2

Glasing Points are the best
No rights or lets. Box of
1,000 points 75 cts. postpaid.

HENRY A. DRESE,
714 Chestnut St., Philadelphia, Pa.

THE FOLEY MFG. CO.

CHICAGO

Completely equipped with up-to-date machinery for the making of material for

GREENHOUSE CONSTRUCTION

From a Full Supply of Thoroughly Seasoned Lumber

Send your sketches to our draughtsmen for completion and suggestion. Permit us to figure your proposed work, large or small.

We guarantee our prices will save you money

FOLEY VENTILATING APPARATUS IS THE BEST

Simple in Erecting. Is Easiest of Operation. It Will Last a Lifetime. Its Price is the Lowest. Will Ventilate Any Size House. Prices and Circulars on Application.

Our 1908 Catalogue Greenhouse Material Sent Postpaid on Request.

**THE FOLEY MFG. CO., WESTERN AVENUE
25th and 26th STS., CHICAGO**

THE STANDARD STEAM TRAP

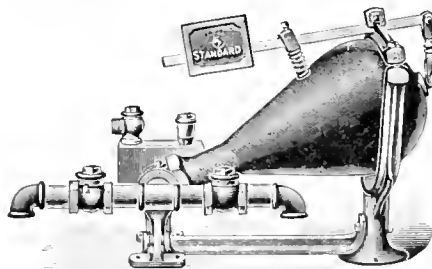

Is acknowledged the best for the florist, because it is durable and does its work without trouble and annoyance, saving its cost by the economy in coal bills.

E. HIPPARD

YOUNGSTOWN, OHIO

In ordering goods please add "I saw it in HORTICULTURE."

SECOND HAND PIPE & BOILER TUBES

Of all sizes, in good condition, suitable for steam purpose, coupled and threaded, for sale at low rates.

5000 feet 1 inch pipe, 3c. per ft.; 5000 feet 1 1/2 inch pipe, 4c. per ft.; 3000 feet 2 inch pipe, 5c. per ft.; 2000 feet 2 1/2 inch pipe, 6 1/2c. per ft.

EAGLE METAL & SUPPLY CO.,
Johnson and Union Aves., BROOKLYN, N. Y.

METROPOLITAN MATERIAL CO.

GREENHOUSE WRECKERS

GLASS Look at these prices. New American 50 ft. to the box, 10x12 single \$1.80 per box, 10x12, 12x12 B. double \$2.20 per box, 12x14, 12x20 and 14x14, 14x20 and 16x16, 16x18 B. double \$2.40 per box, 16x20, 16x24, 12x24 B. double \$2.52 per box. In lots of 10 boxes or more. Discount on large quantities. Let us quote you on

**CYPRESS MATERIAL HOTBED SASH
BOILERS PIPE FITTINGS
HOTBED FRAMES MATS**

1398-1408 METROPOLITAN AV., BROOKLYN, N. Y.

Economy in Heating

MONEY SAVED in fuel and in cost of Operation is as good as MONEY MADE in any other way. In these days of slow business and low prices for your product you can't afford to neglect every chance for SAVING.

THE ELECTRIC CIRCULATOR

This device has been thoroughly tested and proven. Many are now in use. We have a stock on hand of the various sizes READY FOR DELIVERY AT SHORT NOTICE. Applicable either to a new plant or an old one that needs modernizing. Full information as to cost, specifications, etc., to all who ask for same.

The CASTLE COMPANY, Heating Engineers
 170 Summer Street, BOSTON, MASS.

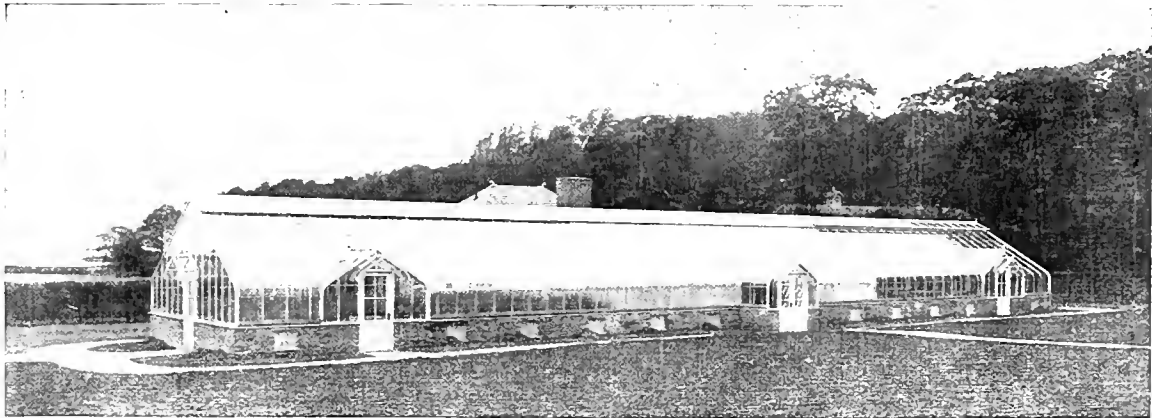

IMPORTANCE OF ADDITION PLANNING

Locate your greenhouse so the additions, which are bound to come, can be made to advantage. We carefully plan U-Bar greenhouses with that in mind. Take for example side entrances are partially framed for con- additions are now being built, and the plan importance of additions rightly handled, don't creased lightness and consequent unmatched construction. Send for Catalog.

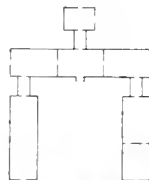

ample this layout at Newport. You see the necting passages for future additions. These shows the layout. But in considering the lose sight of the all important point of in- growing results possible only with this U-Bar

U-BAR GREENHOUSES

PIERSON
 DESIGNERS AND BUILDERS



U-BAR CO.
 1 MADISON AVE., NEW YORK

Some of the Things you Forget

That is to say, you forget that we have them for sale. So this page is a memory jogger.



BENCH FITTINGS

The L & B Clamp kind. One fitting takes legs, side runners and cross braces. Makes an easy to erect, enduring pipe frame bench. Send for circular.



"IDEAL" WHITE LEAD

The strictly pure — made especially for the exacting requirements of greenhouse painting. It makes the "stay put" paint. Send for Booklet.



WIRING FRAMES

A few fittings and some half inch pipe makes a rigid, last forever frame. Send for circular.

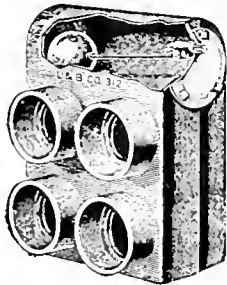

HEADERS

The automatic kind. Prevents dead ends — Save time and labor. Get prices.

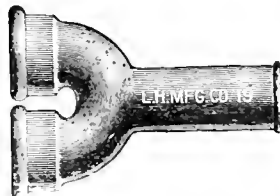

PIPE FITTINGS

When you order your "Burnham" boiler, include fittings. Prices right. Quality, L & B kind.



PIPE HOOKS

Not one kind, but various patterns for clamping to iron, or screwing to wood posts, or any other use. This is a special double clamp fitting which can carry any number of hooks from 4 up to 10. Order these too, along with the "Burnham."

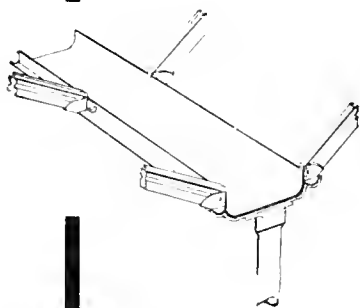

GUTTERS

And this is where you are mistaken, for we carry in stock four distinct types of gutters. So you can't go astray with L & B No. 1908, our Standard Cast Iron Gutter with double side drips; No. 1750 our new V-shaped, with U-Bar drip gutter. Send for prices.

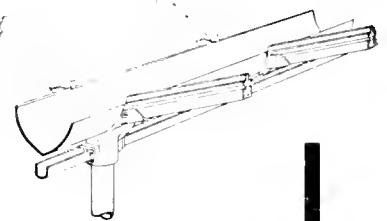

LORD AND BURNHAM COMPANY

BOSTON
819 Tremont Bldg.

MAIN SALES OFFICE
1133 Broadway, New York

PHILADELPHIA
1215 Filbert St.

HORTICULTURE

Vol. VII.

APRIL 18, 1908

No. 16



PRIMULA SINENSIS
Boddington's Giant White.

Photo by W. H. Watt.

Devoted to the
FLORIST, PLANTSMAN,
LANDSCAPE GARDENER,
and
Kindred Interests

Published
EVERY SATURDAY
At 11 Hamilton Place,
BOSTON, MASS.
Subscription, \$1.00

CANNA BULBS

Fine plump, Northern Grown, and in fine condition. Not to be compared with Southern grown stock, that are never thoroughly ripened and therefore are very slow to start growing.

	Doz.	100	1000		Doz.	100	1000
Allemania	\$0.35	\$2.50	\$22.50	Gladiator	\$0.40	\$3.00	\$27.00
Black Prince	.40	3.00	27.00	King Edward	.50	3.50	32.00
Black Warrior	.35	2.50	22.50	Louisiana	.55	4.00	35.00
Burbank	.30	2.25	20.00	Mad. Crozy	.40	3.40	27.00
Black Musafolia	.40	3.00	27.00	Mlle. Berat	.30	2.25	20.00
Charles Henderson	.35	2.50	22.50	Musafolia	.30	2.25	20.00
Director Roe'z	.35	2.50	22.50	Paul Marquant	.30	2.25	20.00
Flamingo	.30	2.25	20.00	Pres. McKinley	.35	2.50	22.50
Florence Vaughan	.35	2.50	22.50	Queen Charlotte	.35	2.50	22.50
Golden Star	.30	2.25	20.00	Robusta	.30	2.00	18.00
				Red Cross	.30	2.25	20.00

STUMPP & WALTER CO., 50 Barclay St., NEW YORK

GERANIUMS A splendid stock of fine plants in 2 inch pots, good standard sorts and new varieties at \$2.00 per 100 and up to \$1.00 each. We will send 1000 in 20 good varieties, our selection, for \$18.50. Our special descriptive **Geranium Catalogue**, describing over 250 varieties of Geraniums and Pelargoniums mailed free to the trade.

NOVELTIES 1907 introductions, from Bruant, Lemoine, Bouchalat and Cannell, one each of 50 varieties our selection, including single and double, for \$5.00.

PELARGONIUMS In good variety, strong plants from 3 inch pots at \$1.50 per dozen, \$6.00 per 100.

HARDY CHRYSANTHEMUMS Our collection of Hardy Chrysanthemums will compare favorably with any in the country and we have an immense stock ready for shipment. Small flowered or Button Varieties, \$2.00 per 100. Large Flowered or Aster Varieties, \$3.00 per 100. Description will be found in our Wholesale List.

DAHLIA ROOTS We still have about 75 varieties we can offer in Cactus, Decorative, Show and Pompon true to name at \$5.00 per 100 and up for Whole Field-grown clumps. One thousand, 50 each of 20 varieties, our selection, for \$40.00, all good kinds; a splendid collection for planting or just the thing for Store Trade.

	Per 100		Per 100
Alyssum, Giant Double	\$2.00	Hardy English Ivy, Extra Strong,	2.00
Ageratum, Stella Gurney	2.00	\$15.00 per 1000	2.00
Begonia, Vernon, White and Rose	2.00	Hardy Hlox	2.00
" Gracilis, White and Rose	2.00	Hollyhocks, Strong 3 in. pot plants, dbl.	3.00
Begonias "Rex" from 2 in. pots	2.00	white, pink, red and yellow	3.00
Cuphaea, Cigar Plant	2.00	Ivy Leaved Geraniums, 6 good kinds,	3.00
Coleus, Verschaffeltii, Golden Bedder and other kinds	2.00	\$25.00 per 1000	3.00
Caladium, Esculentum, 1st size \$2.00 per 100; 2nd size	1.00	Lobelia, Crystal Palace Gem	2.00
Fuchsias, Black Prince and Minnesota	2.00	Lantana, 5 varieties	2.00
Lieutenant Muritz, White and Rose Phenomenal	2.50	Lavender, 2 1/2 in. pots strong	3.00
		Swainsona, Alba	2.00
		Salvia Bonfire and Splendens	2.00
		Tradescantia, Dark Variegated	2.00
		Verbena, Red, White, Purple and Pink	2.00

R. VINCENT JR. & SONS COMPANY, White Marsh, Md.

YOU WANT THEM NOW

Before the cream of the varieties is all sold. The finest stock of standard

HARDY PERENNIALS

in the country. Write and we'll quote tempting prices.

Red Oak Nurseries, Fiskeville, R. I.

AZALEAS for fall delivery, the best that are grown, also **PALMS** for spring or fall delivery, furnished by **AUGUST HAERENS, Somergem, Belgium**; orders booked now.

ADDRESS THE AMERICAN REPRESENTATIVES
AUGUST ROLKER & SONS, 31 Barclay Street, or P. O. Box 752, New York

CANNAS

Send for our List and Prices

The CONARD & JONES CO. WEST GROVE, PA.

Gloire de Lorraine Begonia

2 1/4 inch pots, \$15.00 per 100
\$143.00 per 1000

Thomas Roland Nahant - - Mass.

JOHN E. HAINES Bethlehem, Pa.

is the place to order rooted-cuttings of the following varieties for 1908.

John E. Haines, red	Per 100	Per 1000
Imperial variegated	\$6.00	\$50.00
Pink Imperial		
Enchantress, Light Pink		

Place your orders early for Jan. delivery.

Carnation Cuttings

Both standard varieties and novelties. Stock guaranteed to be first-class. Address,

S. S. SKIDELSKY

1741 North 18th Street, Philadelphia

COLEUS

Verschaffeltii, Golden Queen, Fire Brand, Lord Palmerston, Queen Victoria, Beckwith's Gem. Prices of Rooted Cuttings by express, 60c, per 100; \$5 per 1000. Less than 250 of a variety will be charged at the 100 rate.

Golden Bedder, Hero, Messey, Pearl of Orange. 75c, per 100; \$6 per 1000. Less than 250 of a variety will be charged at the 100 rate.

Fancy Varieties. A very fine assortment of twelve kinds not listed above. 75c, per 100; \$6 per 1000. 250, in assortment, our selection, at the 1000 rate.

MISCELLANEOUS PLANTS

AGERATUM Stella Gurney, Princess Pauline. SALVIA Splendens, Bonfire. HELIOTROPE. Rooted cuttings, 75c, per 100; \$6 per 1000.

CARNATIONS

Rooted Cuttings	100	1000
Winsor	\$6.00	\$50.00
White Perfection	2.50	20.00
Rose Pink Enchantress	3.50	30.00
Enchantress	2.50	20.00
Queen Louise	2.50	20.00

From 2 1/4 inch pots, add \$1.00 per 100.

ASPARAGUS PLUMOSUS MANUS SEEDLINGS
From flats, \$1.00 per 1000.

CHRYSANTHEMUMS

Standard varieties, ready for shipment. Rooted cuttings, \$2 per 100; \$15 per 1000. Send for list.

A. N. PIERSON, CROMWELL, CONN.

GLADIOLI

I can satisfactorily supply your wants for Gladioli for forcing or outdoor planting. Mixtures, color sections or named varieties of exceptional beauty.

Write for Prices

ARTHUR COWEE

Gladiolus Specialist

Meadowvale Farm, BERLIN, N. Y.

GLADIOLUS BULBS

100,000, from 1 1/4 inches up @ \$1.00 per 1000
100,000, 3/4 in 1 1/4 inches @ \$2.00 per 1000

Cash with order. Description given on request. Nice stock of California Privet, \$1.00 per 1000 and up, as to quality. Write for particulars.

Nice lot of American Chestnut Trees at a bargain. Thirty-five large Sugar trees, most of them sample trees.

I. & J. L. LEONARD, IONA, N. J.

CARNATIONS

WINONA - The True Pink
\$12.00 per 100, \$100.00 per 1000

	Per 100	Per 1000
Red Chief	\$5.00	\$40.00
Aristocrat	6.00	50.00
Winsor	6.00	50.00
Beacon	6.00	50.00
White Perfection	3.00	25.00
Rose Pink Enchantress	3.00	25.00
Enchantress	3.00	25.00
Lady Bountiful	3.00	25.00

F. DORNER & SONS CO., LAFAYETTE, IND.

ROOTED

CARNATION CUTTINGS

Only the Best Varieties

CHICAGO CARNATION CO., JOLIET ILL.

ROOTED CHRYSANTHEMUM CUTTINGS

Glory of the Pacific, Pally Rose, Ada Byron, Kath Halliday, Harry Sinclair, Bonnaifon, \$1.50 per 100.

Fair Maid Carnation Cuttings \$1.00 per 100; \$8.00 per 1000.

H. F. Littlefield, 552 Main St., WORCESTER, MASS.

DREER'S SEASONABLE SPECIALS

Hardy Perennial Phlox

We are Headquarters for these. More than one hundred and fifty thousand one year old field grown plants now in pots.

Collection of Choice Standard Phloxes

- Aquillon** (Tall). Bright Tyrian Rose with crimson-red eye.
 - Andreas Hoffer** (Medium). An early and continuous pure white.
 - Bouquet Fleuri** (Dwarf). Pure white with crimson-carmine eye; free-flowering; each branch a perfect bouquet.
 - Bridesmaid** (Tall). White, with large crimson-carmine centre.
 - Beranger** (Dwarf). Ground color white, delicately suffused with rosy pink and distinct amaranth-red eye.
 - Bacchante** (Tall). Tyrian rose with crimson-carmine eye.
 - Clara Beuz** (Dwarf). Lovely carmine rose, with deeper eye.
 - Champs Elysee** (Medium). A very bright rosy magenta of an effective shade.
 - Eclairneur** (Tall). Brilliant rosy magenta with large lighter halo; an excellent variety.
 - Eugene Danzanydier** (Tall). Lilac, shading white toward the edges; large white centre.
 - Esclarmonde** (Tall). Lilac marked with white; aniline red eye.
 - Graff von Ungerer** (Tall). Large flower; white suffused throughout with rosy lilac and dark crimson centre.
 - H. O. Wijers** (Tall). Pure white, with crimson-carmine eye.
 - Henry Murger** (Tall). White with crimson-carmine centre.
 - Inspector Peiker** (Tall). Purplish mauve, washed with white.
 - Jeanne d'Arc** (Tall). A late-flowering pure white.
 - La Vague** (Medium). Pure mauve with aniline red eye; one of the best Phlox in our collection.
 - Otto Thalacker** (Dwarf). Tyrian rose with red eye and light halo.
 - Obergaerber Wittig** (Medium). Bright magenta, with crimson-carmine eye; large flower and truss; the best of its type.
 - Pantheon** (Tall). Bright carmine rose.
 - Pecheur d'Irlande** (Tall). Crimson red, suffused with cochineal-red and carmine red eye.
 - Pacha** (Dwarf). Deep rose pink suffused with softerino-red and carmine-purple eye.
 - Professor Schliebm** (Tall). Pure mauve with crimson-carmine eye; an effective late flowering variety.
 - Papillon** (Medium). Bright violet purple, marked with white.
 - R. P. Struthers** (Tall). Rosy carmine with claret-red eye; one of the best Phlox in cultivation.
 - Sunshine** (Dwarf). Large flower, aniline-red with crimson-red eye and light halo.
 - Thebaide** (Dwarf). Carmine lake with brighter shadings and aniline red eye.
 - Von Goethe** (Tall). Tyrian rose, suffused with carmine lake and carmine red eye.
- Price choice standard varieties.** Strong, one-year-old field-grown plants. 75c. per doz.; \$5.00 per 100; \$40.00 per 1000.

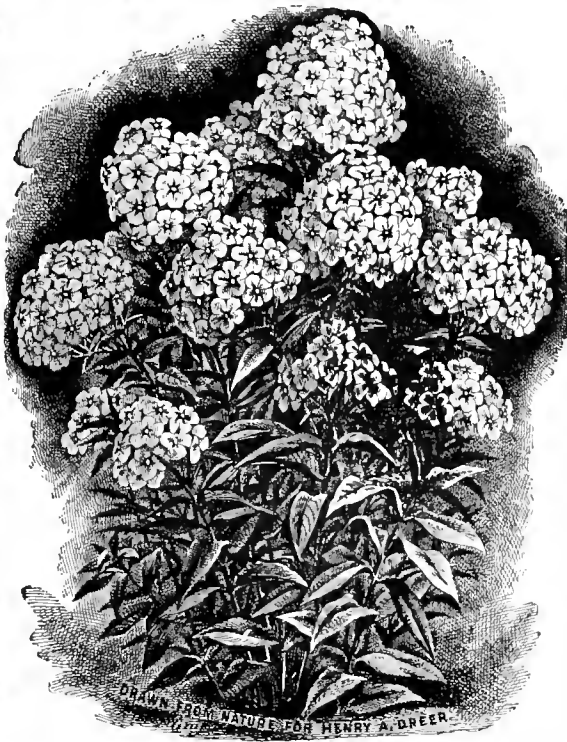

Hardy Phlox

New and Rare Hardy Phloxes

	Pr 100	Pr 1000
Albion. A variety which originated with us several years since. It is a remarkably strong, vigorous grower, producing very large panicles of pure white flowers with a faint aniline red eye. An excellent sort for massing.....	6.00	\$50.00
B. Comte (Tall). A glowing reddish or French purple; one of the finest dark-colored varieties.....	6.00	50.00
Coquelicot (Dwarf). A fine pure scarlet with crimson-red eye.....	6.00	50.00
Fina (Medium). Crim.-red suffused with fiery-red; cherry-red eye.....	6.00	50.00
F.G. von La-sburg (Tall). The finest white in cultivation, the individual flowers being fully double the size of any other variety, pure in color; a strong, clean, vigorous grower.....	10.00	90.00
Hermine (Dwarf). The dwarfest variety in our collection, never exceeding ten inches in height; pure white flowers of good size; early; unequalled for bordering; a perfect little gem.....	6.00	50.00
Inspector Elpel (Tall). Tender rose, with bright crimson-carmine eye.....	6.00	50.00
Jules Cambon (Medium). Very large, reddish purple, with exceptionally large pure white centre; the brightest and most distinct of this type.....	10.00	90.00

	Pr 100	Pr 1000
Le Mahdi (Tall). Reddish violet with darker eye.....	6.00	50.00
Mrs. Jenkins (Tall). An early-flowering, pure white, forming an immense panicle; one of the best.....	10.00	90.00
Michael Cervantes (Tall). Pure white with pure red eye; large flower;.....	6.00	50.00
Selma (Tall). Large flower, pale rose mauve, with distinct claret-red eye.....	10.00	90.00
Vesuvius (Medium). Bright pure red, with French-purple eye; rich and gay.....	6.00	50.00

JAPANESE ANEMONES Not the winter killed or dried up cellared stock so often seen, but established growing plants from three inch pots which will flower early and continuously, one of the most valuable subjects to plant for late summer and fall cut flowers. We offer the following choice varieties.

	per doz.	per 100.	per 1000
Japonica , Rosy red,	\$.85	\$6.00	\$50.00
" Alba. Pure white,	.85	6.00	50.00
" Elegantissima. Semi double satiny rose,	1.25	8.00	70.00
" Lord Ardilaun. Large single white,	1.25	8.00	70.00
" Prince Henry. Double deep rich pink,	1.25	8.00	70.00
" Queen Charlotte. Large double silvery pink,	.85	6.00	50.00
" Rosea Superba. Delicate silvery rose,	.85	6.00	50.00
" Whirlwind. Large semi-double white	.85	6.00	50.00

Japanese Iris—Iris Kaempferi. The stock which we offer is of our own growing, not newly imported, therefore absolutely free of mixtures. We offer twenty distinct varieties and recommend these as a valuable early summer flower.

Named Varieties Strong Roots,	\$1.50 per dozen;	\$10.00 per 100;	\$75.00 per 1000
Choice Mixture	.85	6.00	50.00

Tritoma Pfitzeri—The Everblooming Red-Hot Poker or Flame Flower. We have a good supply of this flowering variety which is so valuable as a decorative cut flower for late summer and fall use. We offer strong roots, \$1.00 per dozen; \$7.00 per 100; \$60.00 per 1000.



Tritoma Pfitzeri

HENRY A. DREER,

714 Chestnut St., Philadelphia, Pa.

HARDY ROSES FOR THE GARDEN

Strong Field-grown Plants

The roses here offered are extra strong two-year-old field-grown blooming plants, which if planted early, will give a large number of flowers the first year. They can be planted as early in the spring as the frost is out of the ground, and from that time until about the first week in May. We offer a grand collection of the best and choicest varieties, as follows:

HYBRID PERPETUAL OR JUNE ROSES

Frau Karl Druschki, Marchioness of Londonderry, Capt. Hayward, Mrs. R. G. Sharman-Crawford, Ulrich Brunner, Margaret Dickson, Baron de Bonstetten, Paul Neyron, Gen. Jacqueminot, Magna Charta, Mrs. John Laing, Mme. Gabrielle Luizet, Marshall P. Wilder, Gloire de Paris, Baroness de Rothschild, Prince Camille de Rohan, Fisher Holmes, Alfred Colomb, Soleil d'Or, Persian Yellow, Moss Roses, Rugosa alba and rubra, etc.

MONTHLY AND HYBRID TEA ROSES

Etoile de France, Killarney, Mme. Abel Chatenay, Countess of Gosford, Koenigen Carola, Perle von Godesberg, Gruss an Teplitz, Maman Cochet, White Maman Cochet, Belle Siebrecht, Hermosa, Mme. Caroline Testout, Souv. de Pres. Carnot, Kaiserin Augusta Victoria, American Beauty, La France, Clothilde Soupert, Prince de Bulgarie, Mme. Norbert Levavasseur (Baby Rambler), Anny Muller (Pink Baby Rambler), Catherine Ziemet (White Baby Rambler), etc.

In Climbing Roses we have a nice stock of Crimson Rambler, Lady Gay, Dorothy Perkins, Dawson, Gardenia, Tausendschon, etc.

LET US KNOW THE QUANTITY YOU WANT AND VARIETIES, AND WE WILL BE GLAD TO QUOTE LOWEST PRICES ON SAME BY RETURN MAIL.

F. R. PIERSON CO., Tarrytown-on-Hudson, New York

ROSES

100 of the best Hardy sorts.

HYBRID PERPETUALS

Finest English Grown Plants

Dozen, \$3.50; 100 \$25.00

EVERBLOOMING HYBRID TEAS

Bloom from Midsummer until frost.

Dozen \$5.00; 100, \$35.00

Hardy Climbing Roses

All the leading sorts.

Catalogue Free on Application.

R. & J. FARQUHAR & CO.

6 and 7 So. Market Street,
Boston, Mass.

FORESTRY PLANTING

10,000 Red Oak, 4 to 6 in. \$50. Ornamental Planting. Swiss Stone Pine, 2 yrs., 3 to 4 in. \$3 per 100, \$25 per 1000. Foxtail Pine, 2 yrs., 3 to 4 in. \$4 per 100. Bal-four Pine, trans., 4 and 5 in. \$6 per 100. Mugho Pine, trans., 6 to 8 in. \$6 per 100. Compakta Mugho Pine, dwarf trans., 3 to 4 in. broad \$7 per 100. Hemlock, 6 to 8 in. trans. \$4 per 100. Larger sizes of all of above. Am. Yew, 10 to 12 in., trans. \$16 per 100. Specimen of Caroline Hemlock, Rk Mt. Spruce, Rk Mt. Silver Fir, 2 1/2 to 4 ft. \$2 to \$4.
JACKSON'S NURSERIES, Portland, Me.

TAUSENDSCHON

or in English **Thousand Beauties**, is the sensational new Climbing Rose of the year. Every florist should have it. It is not excelled for forcing purposes and for general planting by any Climbing Rose now known, **not even bearing Crimson Rambler**. This is the coming forcing Rose. Get your stock early. Illustrated in ten colors and gold in our Catalogue for 1908, the **Leading Rose Catalogue of America**. Every Rose worth having is described in it. Copy free for the asking.

Strong plants of Tausendschon from 3-inch pots,
10 for \$1.50; \$12.00 per 100; \$100.00 per 1000.

THE DINGEE & CONARD CO., WEST GROVE, PA.

HARDY NORTHERN GROWN NURSERY STOCK

At Reasonable Prices

FRUIT AND ORNAMENTAL TREES, SHRUBS, VINES, ROSES AND
HERBACEOUS PERENNIALS IN GREAT VARIETY

Catalogue and Price List for the asking

BAY STATE NURSERIES, NORTH ABINGTON, MASS.

NEW ——— NEW
RAMBLER ROSE "NEWPORT FAIRY"
To be disseminated Spring, 1908. Ask for illustrated pamphlet and prices
JULIUS ROEHRS CO., Rutherford, N.J.

The Roses that Win

MRS. POTTER PALMER, CARDINAL
American Beauty and Other Standard
Varieties. Rooted from Our Famous Stock.
Send for Prices.

POEHLMANN BROS. CO.
Morton Grove, Ill.

RHEA REID

READY NOW, Own Root, \$30 per 100,
Grafted, \$35 per 100.

AMERICAN BEAUTY

Fine Young Stock, \$6 per 100, \$50 per 1000.

THE E. G. HILL CO., Richmond, Ind.

Primula sinensis



GIANT PINK

Now that the time is fast approaching for sowing seed for this beautiful greenhouse annual, a few words regarding it may not be out of place. I do not know of any primula which shows a greater diversity of color in its different varieties; the colors of the flowers ranging from white to deep crimson. Possibly not one of our greenhouse plants has received more attention than the Chinese Primula, and the improvement which has taken place by careful selection and hybridization can only be realized when the improved forms of today are placed side by side with the plant as originally introduced with its insignificant flowers and poor color. Not only has the flower been developed into beautiful single and double forms of superb color, but the foliage itself has undergone such changes that the plants are very ornamental subjects before the flowering period is reached.

Perhaps it would be well to mention a few of the choicest varieties at present in cultivation as a guide to growers in selecting their seed for the present season's sowing. The following named varieties are among the best that have been produced and worthy of a place in any greenhouse:

Crimson King, a fine deep crimson with individual flowers measuring nearly two inches in diameter, ten to twelve flowers being produced on the umbel while at least three inflorescences are borne by the plant during the flowering period; Giant White, a remarkable white variety; The Duchess, pink, dark in the center and approaching white near the outside of the corolla; The Czar, dark blue; Pink Beauty, blush pink, with flowers two inches or more in diameter; Giant Pink, large pink flowers borne on immense umbels and certainly one of the best forms of *Primula sinensis*.

Primula sinensis is not at all difficult of culture but like most other plants repays the cultivator who exercises great care in its cultivation. And surely a plant which blooms continually for a period of from eight

to twelve weeks is deserving of the most careful treatment. The flowering period may be lengthened if successive sowings are made from the beginning of May until the end of June or even later. Clean pots should always be used, preferably new ones, care being taken to soak them for a few minutes in water. Good drainage should be provided because it is only by paying attention to seeding trifles that good plants can be grown and the primula greatly resents a stagnant condition of soil moisture.

Five-inch pots or pans are good for seed sowing purposes and after drainage is afforded, the compost, which consists of good fibrous loam and leaf soil in equal proportions, run through a half-inch sieve and mixed with a small amount of sand, should be placed fairly firm in the pots to within half an inch of the top. Sand should then be sprinkled thinly on the surface and the seeds evenly but not too thickly distributed on the sand. The seeds should then be covered very lightly with a layer of fine soil and, after being carefully watered in, the pots should be allowed to drain and then be placed in a sheltered position in the greenhouse.

During germination a temperature of from 60 to 65 degrees should be maintained, never allowing a rise above 70 degrees F. When the seedlings are large enough to handle, prick them off singly around the edges of small pans and keep them close for a few days until they are established, after which admit air in gradually increasing quantities until the plants will bear placing in their permanent quarters. Transfer to thumb pots and when these are filled with roots move the plants as requisite to larger pots. Expose freely to the air during the hot months of the year, always remembering to afford protection from draughts and to provide shade from the direct rays of the sun.

Throw away all sickly plants and always aim at producing robust growth, not forgetting that the *Primula* strongly resents any attempt at rapid forcing and the longer the period of growth the stronger the plants will be.

Always bear in mind that the art of the gardener consists not only in knowing what to grow or what to keep but also in what to throw away, and remem-



THE CZAR

very fastidious in its tastes, this is the most attention to details that can be expected to succeed.

H. J. Moore

London

British Horticulture

WINTER AND WEDDING CARNATION SHOW

There was a very interesting display at the spring show of the Winter Flowering Carnation Society at the Royal Horticultural Hall, London, on April 1st. The Guernsey growers were again well to the fore in the prizes. H. Burnett had a meritorious collection, the best of which a gold medal was awarded. An award of merit was granted to Mr. Barnett for *Mexico* and a first-class certificate for *Marmion*. W. H. Lucas and another Guernsey grower took the first prize for 18 blooms of a variety not in common with *Pauline*, a variety of a deep rose tint. There was only a single entry in the class for varieties new to the market. The judges expressed a wish to see *Barnswell* show again in the winter. In the class for white blooms *White Perfection* carried off the premier prize. *Enchantress* was the winner in the blush section, and *Fiancee* was the winning pink. *Harlowarian* was able to beat its rival in the crimson section, whilst Robert Crair was the best scarlet. *Jessica* took the chief award in the fancy section. At the annual meeting a satisfactory report of the Society's progress was presented by Hayward Matthias, the Hon. Secretary, through whose zeal and energy the Society was brought into existence.

THE SUMMER SHOW

The National Carnation and Poinsettia Society, which is responsible for the summer show, has issued its annual report and schedule. Several new classes have been added and classes for undressed flowers. The object of the four new classes for dressed flowers is to encourage the cultivation of bizarres, and white-ground pinks, which to some extent have been neglected of late. Alterations have been made to the open section of the schedule, regarding the trade. A valuable challenge cup has been offered by R. C. Cartwright, a member of the committee. A class has been added for single flowers in a vase. It is stipulated that the flowers must be from plants that have bloomed at least the second year. The committee explain: "It is open to growers that seedlings blooming for the first time give flowers of fine excellence and great promise, but afterwards deteriorate to such a degree that render them useless for exhibition and unpleasing to the public."

A NEW CHERRY DISEASE

E. S. Salmon, biologist to the South-eastern Agricultural College, at Wye, has published some details of a fungus disease affecting cherries which made its appearance last summer in Kent. The disease causes the leaves of the cherry to curl, and at this period they become pinkish-red in color. A delicate whitish bloom is visible, spreading over the greater part of the under-surface of the leaf. Then the affected leaves turn brown, and quickly blacken and rot off. The name of the fungus causing the disease, Mr. Salmon states, is *Exosporium cerasi* Sacc. It is closely allied to *E. deformans* Eckh. which causes the leaf curl or blister of the peach, and also to *E. Cerasi*. It does not appear

that this disease has been recorded hitherto as occurring in this country. Possibly it has been confused with the "Witches Broom" disease caused by *E. Cerasi*, since in both cases the leaves on the affected shoots turn a pinkish red color. The cherry tree when attacked exhibits a curious malformation among the branches, so that at a distance it looks somewhat as though a bunch of mistletoe were growing there. The suggested remedy is as follows: "The disease can be cured by pruning. As the spawn of the fungus is perennial, living on from year to year, in the buds and young wood, it is absolutely necessary to cut off each affected branch well below the last diseased leaf. The spawn does not extend backwards, or downwards into the lower main branches or the stem, consequently the pruning will completely remove the disease. It is well, however, to spray during the first season with Bordeaux mixture (using 4 lbs. copper sulphate, 4 lbs. quicklime, 50 gallons water) at the time when the leaves are just expanded.

W. J. Adsett.

Bark Effect and Pussy Willows

I am delighted to learn that Mr. Rehder is to give us through HORTICULTURE notes from that greatest of all American horticultural repositories, the Arnold Arboretum. I have been advocating for a number of years the planting of shrubs and trees with colored bark in groups so as to be effective. To the list given by Mr. Rehder in your issue of April 4 for bark effect add *Salix Jeanne d'Arc*—intermediate between *Viminalis* and *Britzensis*—and *S. violacea purpurea*. To get the very best bark effects all the *salices* should be pollarded so as to produce long whip-like shoots. About six or eight of these are a delight and that's about as many as can be left on a stump. Thin 'em out the same as you do the cherry shoots.

In a group of shrubbery a day or two since I was impressed with the effect that the common buckthorn (*Rhamnus fraxinea*) with its coal-black bark made between the red *Cornus stolonifera* and the golden willow, *Viminalis*.

In Jackson Park there are some points where the common matrimony vine has been permitted to run free—and it certainly has rioted—mostly on corners, and to lay with its cream-colored withes from 4 to 6 feet long. It is beautiful—that's all. Remember this old matrimony vine all of you, and use it for banks, for hanging over walls or anywhere it can hang over.

I have never seen finer pussy-cat willows than there are in the neighborhood of Chicago. Every ditch in the prairies, where it is as wide as an ordinary bathtub, is furnished with them. I particularly wish to draw your attention to *Salix dasystyla*, a Japanese species. It has the largest, most brilliantly-colored catkins of all of the willows. Now, of course, you will not keep this a secret but I want to tell you, anyhow, that just as soon as this Japa. pussy-cat willow gets known it will be grown in pots by the thousand for Easter. Willows can be grown in pots as easily as chrysanthemums.

John Thorpe

A Fern Fed With Soluble Fertilizer



The fern pictured here (*Nephrolepis Barrowsii*) was fed entirely on soluble chemicals. These were free from soda, sulphates or chlorine, and were applied dissolved in water, which was also used on the general run of plants in the same house.

As pictured, the fern has already suffered the usual penalties incident to exhibition. At the recent show at Horticultural Hall, Boston, J. L. Smith, gardener at Mrs. Arthur W. Blake's Brookline establishment, received many compliments and a cultural award this being the second received for this specimen, which Mr. Barrows said was "the best ever."

Three years ago this coming June it was a little fellow in a two-inch pot fresh from the originator and now has a spread of nine feet or more, measured as a bird, from tip to tip. The fern tub is hidden, while the barrel upon which it is placed is twenty inches at the small end which is plainly visible.

This is yet another living demonstration of the truth that properly used soluble foods make plants just as fit for the long run as they may for the sprint, although many folks reason that because their action is rapid and immediate it must of necessity be also soon spent and the plant must "go back." This fern has had over thirty moons to "go back."

The strength of fertilizer used made the nitrogen strength one part in 13 thousand of water while the phosphate and potash were about the same strength, which figures about one part to 7 thousand of water making, it will be noticed, a "complete" fertilizer.

For nearly three years the fern has softly said to the nice clean fertilizer barrel across the walk in the corner, "Love me little, but please do love me long."

"Iron-Clad" Rhododendrons

In your issue of April 11 in the article on Rhododendrons is given a list of "sure hardy ones which are able to withstand our vigorous winters." I am quite surprised at the make-up of this list. It does not, with a few exceptions, accord with my experience.

My comment on the list would be as follows:

Everestianum, hardy. Alexander Dancer, hardy in some exceptional locations, and if protected in winter. Mrs. John Clutton, tender, unless the plants are so small that they are covered by snow in winter. Concessum, tender. Charles Bagley, possibly hardy; hardy in vicinity of New York city. Mrs. A. Waterer, tender. The Queen, tender; hardy at Philadelphia. August Van Geert, tender. John Waterer, tender. Mrs. R. S. Holford, tender. Hannibal, hardy. Lady Eleanor Cathcart, tender.

Of course any of the above sorts would probably come through the winter all right if covered clean out of sight each year with leaves, but the necessity of handling them in that manner would put them outside the hardy class. I am now speaking for the vicinity of Boston, not further south. Also during some winters all of the above varieties might come through all right without protection.

To repeat a more or less old story I give below a list of so-called "iron-clad" varieties. (There is no iron-clad list in the sense that that term can be applied to a common lilae.)

White, or substantially so:—Maximum, Delicatissimum, Album elegans, Album grandiflorum (in some locations).

Pink:—Hannibal, Roseum elegans, Lady Armstrong, James Macintosh.

Bright red:—Mrs. Milner, Charles Bagley (in some locations), Atrosanguineum (in some locations), H. W. Sargent, Gen. Grant, C. S. Sargent.

Lavender and lavender purple:—Everestianum, Purpureum elegans.

Dark red:—Caractacus, Chas. Dickens, Kettledrum, Old Port (perhaps).

There are undoubtedly others which might be added to the above list.

At the Arnold Arboretum may be found in addition to the above the following apparently hardy under the ideal conditions and care which prevail there. F. L. Ames, Norma, Charles Thorold, Milton, Marion, Mrs. Charles Sargent, R. S. Field, Henrietta Sargent, Mrs. Harry Ingersoll, Coriaceum (early blooming dwarf, probably a tall plant of it in an exposed situation would be tender).

Could Mr. Brown give us an account how he has handled the varieties he has mentioned and how long he has had them?

Rudley M. Pray

Chas. J. Kochler

HORTICULTURE

VOL. VII

APRIL 18, 1908

NO. 16

PUBLISHED WEEKLY BY

HORTICULTURE PUBLISHING CO.
11 Hamilton Place, Boston, Mass.

Telephone, Oxford 292
WM. J. STEWART, Editor and Manager

SUBSCRIPTION PRICE

One Year, in advance, \$1.00; To Foreign Countries, 2.00; To Canada, \$1.50

ADVERTISING RATES

Per Inch, 30 inches to page \$1.00.
Discounts on Contracts for consecutive insertions, as follows:
One month (4 times) 5 per cent.; three months (12 times) 10 per cent.;
six months (26 times) 20 per cent.; one year (52 times) 30 per cent.
Page and half page spaces, special rates on application.

Entered as second-class matter December 8, 1904, at the Post Office at Boston, Mass., under the Act of Congress of March 3, 1879.

CONTENTS

	Page
FRONTISPIECE—Primula sinensis.	
PRIMULA SINENSIS—H. J. Moore—Illustrated.....	525
BRITISH HORTICULTURE—W. H. Adsett.....	526
BARK EFFECT AND PUSSY WILLOWS—John Thorpe	526
A FERN FED WITH SOLUBLE FERTILIZERS—Dudley M. Pray—Illustrated.....	527
"IRON-CLAD" RHODODENDRONS—Hans J. Koehler.	527
GARDENERS' AND FLORISTS' CLUB OF BOSTON—Illustrated	529
NEWS OF THE CLUBS AND SOCIETIES:	
Pittsburg Florists' and Gardeners' Club—Pasadena Gardeners' Association—Society of American Florists	530
Horticultural Society of New York.....	531
New York Florists' Club—Morris County Gardeners' and Florists' Society.....	532
St. Louis Florist Club—Connecticut Horticultural Society—Club and Society Notes.....	533
SEED TRADE	534
PLANT NOTES	536
OF INTEREST TO RETAIL FLORISTS.....	538
Detroit—New Retail Flower Stores.....	538
FLOWER MARKET REPORTS:	
Boston, Buffalo, Chicago, Indianapolis, New York, Philadelphia, Twin Cities.....	541
MISCELLANEOUS:	
Entire Satisfaction.....	529
Publication Received.....	529
A Testimonial	529
Martial Bremond—Portrait.....	532
Catalogues Received	534
Plant Imports	536
Movements of Gardeners.....	536
Fire Record	536
Missouri Botanical Garden.....	536
During Recess	536
Obituary	536
Business Changes	536
Killarney's Chicago Home.....	536
News Notes	539
Detroit's Good Example.....	539
Exhibition at Buffalo.....	541
Greenhouses Building or Contemplated.....	549
List of Patents.....	549

has been going on and some good results are already in evidence and from the viewpoint of the plantsman this would seem to be the most promising direction in which special effort might now be made. To combine in one type the massive, brilliant colored flowers of the Chinese with the loose habit and graceful poise of the stellata is an object well worth looking forward to although quite a simple proposition as compared with some of the mergers for which the ambitious primula hybridizer has for years been straining every nerve.

The fate of the staggard We understand that the Pekin Gazette has suspended and the reason given is that it "fell behind the times." Its age is given as 4000 years! We recall not a few florist, nursery and seed establishments that have fallen by the wayside for the same reason and there are others languishing along which are doomed to a like fate, to all intents and purposes as antiquated in their ways as the unfortunate Chinese newspaper. It is a bad sign of any business institution when younger rivals having little or no assets except their push and courage outdistance it in the race. It is then full time for the laggard to look about and see wherein he lacks; to adopt a more wide-awake policy; to investigate and get into direct touch with up-to-date goods and modern ways. What was good enough for the customers of a dozen years ago is not good enough today; take that fact to heart and instead of wasting time and temper in predicting disaster for your hustling young competitor, "get a move on" yourself before it is too late.

A superfluous commodity The time when American dealers and florists are accustomed to hand over to the importunate Dutchman their orders for bulbs for next season's use is now at hand. We do not think our friends from across the Atlantic are likely to go home this year in any very jubilant frame of mind over their American orders. The bulb forceer is pretty sure to hold fresh in his memory the experience of the past season which has proclaimed in unmistakable terms the decadence of this once flourishing and profitable industry, and the retail seed houses will not care to stock up heavily on bulbs which, as last year, are likely to be left on their hands, at the top-notch prices they are now asked to pay. Apart from the mere whims of fashion there are good practical reasons for the American flower buyers' neglect of the forced Dutch bulb. One reason is the great advance made by the American florist in the production of superb winter roses and carnations and the enterprise displayed in the growing of a wide variety of sweet and charming flowers for the winter trade which a few years ago were not thought of for this purpose. We are glad it is so. The rose, the carnation, violet, sweet pea, or other flowers of like character are of home production from root to tip and to those who grow them in such perfection as we now find them in the flower markets should the money go instead of into freight and duties and the pockets of foreign growers who have for a third of a century been getting rich on American business and have at every opportunity advanced prices on anything that developed popularity in our markets. We advise our bulb buyers to take their time about placing import orders this season. As soon as our visiting travelers come to realize that the bulb flower has lost its prestige with the American trade the imperial foreign authority which dictates the minimum price at which any Dutch bulb may be sold is destined to hear something drop.

The Chinese primrose We give especial prominence to the Chinese primrose in this issue. The development in this useful little plant within a few years, up to the superb standard shown in our frontispiece, is the result of patient, assiduous work on the part of the hybridist and seed grower. In color the advance has been little short of marvellous. Lately, crossing with the stellata and obconica sections

GARDENERS' AND FLORISTS' CLUB OF BOSTON



Members of the Boston club to the number of sixty visited on invitation the noted plant growing establishment of Thomas Roland at Nahant, Mass., on Saturday, April 11. The visit was not only a grand recreation but had, besides a distinctive educational value. Mr. Roland stands in the foremost rank as a plant grower, and something of value may be learned from every corner of his establishment. Here are a few things we learned on this occasion:

We saw a house partially filled with Van der Cruyssen and other azaleas, more profusely flowered than any we have ever seen, under any conditions, anywhere. Imported this year? No, sir! They were plants left over last Easter on the hands of another grower, which Mr. Roland purchased, planted out in the field in full sunlight, dug up in the fall before frost came, and there they are, actually with buds so thickly set that the flowers have not room in which to open. And the foliage is grand as well.

Plant buyers, in Boston at least, prefer their Rambler roses in moderate sizes, trained low so that when in bloom they give a bush effect. Among the single-flowered varieties Hiawatha takes the lead. As to color it is not easy to tell Lady Gay and Dorothy Perkins apart. Both develop a brighter pink if grown under a little shade, but in the full sun they are less likely

to grow soft. The habit of Lady Gay has the advantage in garden culture but Perkins is a better subject for pot use with its lighter growth and less massive flower clusters. Mr. Roland does not encourage big strong growth in these pot ramblers, light sprays making a more pleasing plant when in flower.

Baby Ramblers, one year old, home-raised from rooted cuttings, make a big show and are just the thing for the cheap trade at Easter. There is almost no limit to the demand. Catharine Zeimet, an imported Baby Rambler, bears semi-double white flowers, deliciously fragrant, but the petals drop too quickly to permit its having any value as an Easter subject.

Hydrangea Jean d'Arc, with dark red stems and pink perfects contrasting prettily with the pure white flowers, is a better grower than the old Thomas Hogg and makes a superior Easter plant.

A long line of cold frames filled with sturdy chrysanthemums attracted attention from the fact that these chrysanthemums had wintered over without any other protection than a banking of leaves and a covering of double sash. A new plant house, 34x140, recently finished, is filled with young candy tuft which will produce a crop for Memorial Day that will make a big hole in the bill for building the house. There are acacias in several

varieties, hundreds of Bougainvillea Sanderiana not bare-stemmed as usual but carrying the old foliage in perfection and loaded with bloom, ericas in rich variety but "too rich in price for Boston's purse" says Mr. Roland, thousands of cyclamens and tens of thousands of Lorraine begonias for next season. And why is it that everything looks so remarkably bright and healthy? Well, we can't answer the question in full; part of the explanation is in the man himself, no doubt, but it is worth recording that the ventilators were all wide open and a howling breeze from the Atlantic, which was strong enough to lift one of the sashes piled up outside and carry it a dozen feet to destruction, was tearing through the houses, and the roses, acacias, genistas, campanulas, azaleas, hydrangeas and ericas seemed to fairly revel in it! Again, we noticed that every individual plant had lots of room to itself.

President Westwood of the Boston Club voiced the gratitude of the visitors for the kind entertainment extended and three lusty cheers were given for the host of the occasion. Next the party was photographed and then proceeded on the homeward ride, little realizing as they heard the train man call out "Chelsea," as they passed through the quiet town, the awful destruction that was to visit it on the morrow.

"ENTIRE SATISFACTION."

Wm. J. Stewart, Esq.,

Boston, Mass.

Dear Sir:—

We find from the advertising already done that we shall be thus able to sell all the aster seed we have to spare and more, too, consequently shall not care to continue further this spring and will here enclose P. O. Order to balance account with you, besides thanking you for the favors you have shown us in the past few months.

We expect to have a much larger supply of our special Imperial aster seed for sale another fall and if so

shall patronize your journal more liberally.

You have in fact given us entire satisfaction; the results coming direct from your journal have been more than double our anticipation.

Respectfully yours,

(Signed) CHAS. A. KIRBEE.

Elmhurst, Ill., April 13, 1908.

PUBLICATION RECEIVED.

Board of Park Commissioners, City of Minneapolis, Minn., 25th Annual Report, 1907. A beautiful volume, finely illustrated and full of interesting facts concerning this rapidly developing metropolitan park system under the able management of Theodore Wirth as superintendent.

A TESTIMONIAL.

Horticulture Publishing Co:

Please discontinue our advt. of Grafted Roses, as we are in receipt of enough orders to clean out our own stock. Orders have come in fast this year. The first week our advt. appeared in your paper we sold over 6000 plants. I like HORTICULTURE for its original and valuable reading matter, apart from its value as an advertising medium, and have frequently heard it well spoken of.

Respectfully,

E. HOLMES.

Montrose Greenhouses.

News of the Clubs and Societies

PITTSBURG FLORISTS' AND GARDENERS' CLUB.

The meeting of the club on April 7th had for its subject, "Easter Plants and Flowers," with a competitive exhibition, which drew a good attendance. The hall of the club being too small for the display and attendance, the meeting was held at 222 Oliver Ave. President Burki being absent on account of sickness, Vice-President Reineman took the chair.

As a committee to look after the exhibits and interests of the private gardeners for the period ending May, 1909, the chair appointed J. Hutchinson, David Fraser, Jas. Wiseman and H. S. Price, and as judges of the competitive exhibit, Jno. W. Jones, C. S. Crall and Jno. Bader.

There were many visitors present and among them Mr. Myers of Altoona, who called attention to Spirea Queen Alexandra. W. A. Clark spoke of his visit to the recent rose show at Chicago. He did not find as much enthusiasm in Chicago over the rose exhibition as he expected. The quality of the flowers shown was of a high order, but the varieties were few. Among the novelties Wyndmoor, with its bright deep pink attracted him. Mr. Wilson defended the enthusiasm and interest of Chicago, as a general rule, in flower exhibitions, and thought if it was lacking in the recent case it was owing to some special reason. Jno. Bader talked of lilies, and mourned the old days when the Harrisii was in its prime. He has success now only with giganteum. Mr. Matthebranc of Johnstown, who has 4,000 giganteum with a loss of only six, and who has had excellent success in growing lilies for many years, thought that many lilies were spoiled by over-watering, and that if greater care was exercised in the watering there would be many more lilies to send to market. He has better success with plants in 4 in. pots than 6 in. While he keeps his houses moist, he is careful to keep his plants on the dry side. Mr. Bader spoke again of the limitations that Pittsburg and vicinity labor under in the way of soot and smoke, and the atmospheric conditions they seem to bring about, which prevent the successful growing out-of-doors of tuberous begonias, asters, stocks and other flowers.

Exhibits and awards were as follows:

Private growers: N. C. Madsen, gardener for R. H. Boggs, special mention for well-grown Salpiglossis Emperor; Frank Crook, special mention for Nicotiana glauca and marguerites.

Commercial growers: Chas. Koenig, special mention for Begonia Vernon and first prize for longiflorum and giganteum lilies; H. L. Blind & Bros., first for azaleas and hyacinths and second for hydrangeas.

There were fine displays of carnations from Finleyville Floral Co. and yellow callas and variegated box elder from Phipps' Conservatories.

The subject for next meeting will be, "Bedding Plants," with speakers to be assigned by the president to certain topics, as geraniums, cannas, etc.

H. P. JOSLIN, Secretary.

PASADENA GARDENERS' ASSOCIATION.

The third annual spring flower show was held on April 2, 3, 4, under the auspices of the Pasadena Gardeners' Association, in a large tent on North Fair Oaks avenue, Pasadena. The show was said to be the finest of its kind ever held on the Pacific Coast. The new florist club of Los Angeles attended in a body (in a special car), bringing with them a magnificent bouquet of Chateaux roses which they presented to the management of the show. Among the visitors was Dr. Houghton who, representing Mayor Hooper of Los Angeles, extended his congratulations on the success of the show. Winners of prizes in the carnation classes were Hugh Thornton and J. Blake, private, and Redondo Improvement Co., and Whittlessey Floral Co., commercial. On stocks Geo. Dill, Redondo Im. Co., J. Blake. Pansies, M. Randall, A. Busch, R. J. Fraser, J. Macgilvray. Iris, T. Lambert, W. S. Laurie, Mrs. Ramsay. Bulbous flowers, C. H. Hovey and W. S. Laurie. Scabiosa, calendula, pentstemon, verbena, antirrhinum and other garden flowers were all provided for in the schedule, and prizes awarded for handsome exhibits in all these classes. In general cut flowers C. A. Campbell Johnstone and Redondo Im. Co. were first and second. A. K. Macomber on orchids. Park Nursery on palms, D. R. Cameron on begonias, cyclamens and Asparagus plumosus, and A. H. Fleming on ornamental plants were also among the first prize winners.

Edward Rust of Palm Nurseries received a certificate of merit from the Pasadena Gardeners' Association for a display of fancy caladiums and decorative plants. Robert Pegg of the Mentor Nurseries, Pasadena, had an exceptionally fine exhibit of decorative plants. Howard Smith had a magnificent display of new amaryllises, watsonias and ferns. Theodore Payne was awarded a special prize for collection of California wild flowers. J. H. Booreman was also awarded a special prize for fine group of cacti. Special prize was awarded to Mrs. C. C. Bragdon for cinerarias. There was also a fine display of water lilies in the middle of the tent beneath a large fountain.

Much of the success of the show is due to the efforts of the officers and directors of the Pasadena Gardeners' Association, who are Robert Pegg, chairman and manager; Richard Thomas, secretary; P. W. Janoek, G.

**FLOWERING PLANTS
BEDDING PLANTS
CHOICE SHRUBBERY
SUMMER BULBS**

BEST EVER OFFERED

W. ELLIOTT & SONS
201 Fulton St., New York

TOWER HOTEL Niagara Falls, N. Y.

is soliciting your patronage during the S. A. F. Convention.

Very truly yours,

M. J. HOENIG, Prop.

F. Ni on, R. Kroll, John Blake, G. A. Sawyer, Jas. Macgilvray and A. T. Hanson.

SOCIETY OF AMERICAN FLORISTS AND ORNAMENTAL HORTICULTURISTS.

Notice of Change of Registered Name of Rose.

The Waban Rose Conservatories of Natick, Mass., make application to have the name of their rose previously registered as White Killarney changed to Mavourneen. Public notice is hereby given of this application and any persons objecting to this proposed change of name or knowing of any reasons why the name should not be changed as above are requested to forward a statement of their objections to the undersigned at once.

No objections being received within twenty days of this date, a change in registry will be made.

W. N. RUDD, Secy.

500,000 Palmetto Asparagus Roots

2, 3 and 4 Years Old

Well developed. Grown on Bloomsdale.
Trade Price, - \$3.50 Per Thousand.

No Order will be taken under One Thousand

D. LANDRETH SEED COMPANY, - - Bristol, Pa.
Bloomsdale Seed Farms.

HORTICULTURAL SOCIETY OF NEW YORK.

For the purpose of encouraging the cultivation and the study of orchids and the formation of orchid collections a committee of the Horticultural Society of New York has been established for the purpose of forming an orchid section.

This action is the outcome of the recent gathering of a few orchid specialists in New York, as it was the unanimous feeling of those who took the initiative that the times were not propitious for the forming of an independent society. The Horticultural Society of New York in forming this orchid section gives perfect autonomy to the section which will be free to make its own rules and regulations for the exhibiting of orchids.

The first step is made in connection with the forthcoming announcements of the May exhibition to be held in the New York Botanical Garden on May 13th and 14th, when besides four cash prizes, two for amateurs and two open to all, there will be offered one gold medal, three silver medals and three bronze medals, these medals to be awarded at the discretion of the orchid committee, which is composed as follows: C. Moore, Hackensack, N. J., chairman, and J. E. Lager, J. A. Manda, G. V. Nash, H. A. Siebrecht, J. W. M. Kitchen and E. H. Roehrs, Rutherford, N. J., secretary.

In ordering goods please add "I saw it in HORTICULTURE."

The Leading Horticultural Paper on the Continent
LA TRIBUNE HORTICOLE

PUBLISHED WEEKLY

Official Publication of the Royal Linnean and Flora Societies of Brussels and the National Commission of Pomology of Belgium. Ordered by the Board of Education for the Schools and Scientific Institutions by the Board of Agriculture and the Board of Justice.

Well Written Up-to-Date Splendidly Illustrated

LA TRIBUNE HORTICOLE gives Cultural Information, also all the Gardening News and Full Reports of the Horticultural Meetings and Shows held on the Continent.

12 Water Colored Plates & 40 Half Tone Supplements in each volume

It is the CHEAPEST and best Gardening Paper in Belgium, forming each year a splendid volume of 832 pages of text and 52 SUPPLEMENTARY ILLUSTRATIONS.

LA TRIBUNE HORTICOLE has the Largest Circulation on the Continent, and is the best medium for advertising.

Annual Subscription 8/-. Post Free.

Specimen Copy Post Free on application.

Offices - - - 43, RUE VONCK, BRUSSELS

JOHN WATERER & SON, Ltd.
American Nursery, Bagshot, England

Are Specialists in the

REALLY HARDY VARIETIES

of Rhododendron Hybrids and in Select Varieties of Hardy Border Plants.

Single Chrysanthemums ARE THE CRAZE

for the time being.

Are you in line to meet the demand?

I have now ready

KATIE COVELL, ROB ROY, HELEN TOTTY, HAROLD BISHOP, MRS. UNTERMEYER, ANNA SPANGLE.

and others, at

\$2.00 per doz., \$15.00 per 100.

I also carry a full line of novelties and standard varieties of

Chrysanthemums, Carnations and Roses

CHAS. H. TOTTY, MADISON, N. J.

DAHLIAS.

varieties in any quantity; prompt

Now is the time to place your order for bulbs which will insure you getting named varieties delivery.

DAVID HERBERT & SON,

Successors to L. K. Peacock, Inc. ATCO, N. J.

100,000 DAHLIAS

Premium Stock, guaranteed true to name.

500,000 large Flowering Gladioli, hundreds of colors and variations mixed Wholesale prices on application. Order now for spring delivery. Catalogue free.

J. L. MOORE, Northboro, Mass.

LIVE FENCES

We believe we are the largest growers of Hedge plants in America—Privet our specialty—can supply any quantity both

Amoor River and California, strong plants, at \$25.00 per M. Other varieties. Prices on application.

PETER'S NURSERY COMPANY, - Knoxville, Tenn.

The MORRIS NURSERY CO.

West Chester, PA.

NURSERIES ESTABLISHED 1849

SPECIALTIES for SPRING 1908

Norway Maple, 2 2 1/2 in dia, and 2 1/2-3 in dia
Carolina Poplars, 10-12 ft., 1 1/2-2 in.
Cal. Privet Hedge Plants 2 yrs. old 2-3 ft. and 3 and 4 yrs. old 3-5 ft Dwarf Box, 3-6 in.
Rhododendron Hybrids, 18-24 in. and 2-3 ft. choice hardy varieties Rhododendron Maximum, 2-8 ft., fine plants in car lots.
Kalmia Latifolia 1-4 ft., fine plants in car lots.
Blue Spruce, Koster's, 3-5 ft.
Hybrid Roses, choice varieties.

Catalogue mailed upon request. Address all communications to

The MORRIS NURSERY CO
Sales office, 1 MADISON AVE., NEW YORK

Hardy Rhododendrons Azaleas Conifers, Clematis, H. P. Roses, Shrubs and Herbaceous Plants from our **HOLLAND NURSERIES**
Prices Moderate

P. OUWERKERK, 246 Jane St., Weehawken Heights P O No. 1 Hoboken N J.

AMERICAN NURSERY CO., COMBINING

FRED'K W. KELSEY, New York City
F. & F NURSERIES, Springfield, N. J.
BLOODGOOD NURSERY, Flushing, L.I.
N J & L I. NURSERIES

We can supply you very need. Write for prices
Sales Department
150 BROADWAY, - NEW YORK

RHODODENDRONS

Hardy Hybrids - 1 1/2 ft, 2 ft., 3 ft., 4 ft., 5 ft.

Box - All sizes Bush, Pyramid and Standard.

Roses - Large assortment, Hybrid and Climbing.

Herbaceous Perennials, 1000 varieties

Send for General Catalog and Trade List

The NEW ENGLAND NURSERIES, Inc. BEDFORD, MASS.

Established 40 Years

Rose Hill Nurseries

New and Rare Plants

NEW ROCHELLE, N. Y.

New York Office, Siebrecht Building, 425 Fifth Avenue

ROBERT CRAIG CO.

ROSES, PALMS,

and Novelties in Decorative Plants

MARKET and 49th STREETS, PHILADELPHIA, PA.



Mr. FLORIST
Why Don't
You Sell

VASES

Every vase sold
means more
business for you

This Business
belongs to you

Will you let us
show you how
to get it?

Write for
Catalogue "B"
on VASES

The Kramer
Bros. Fdy.
Company
DAYTON, O.

Largest Mfg. of
Vases in the U.S.

Martial Bremond

WHOLESALE GROWER OF FRENCH BULBS

— OLLIOULES, FRANCE —

A superior quality supplied at
market prices. Shipments made
direct. Cases marked to order.

Sole Agents

RALPH M. WARD & COMPANY
12 West Broadway - - NEW YORK

CHRYSANTHEMUMS

All the Popular Varieties.

Rooted Cuttings, per 100, \$1.00: per 1000, \$8.00

GERANIUMS

A Large Assortment of the Choicest Kinds.

From 3 1/2 in. pots, \$7.00 and \$8.00 per 100.

WM. W. EDGAR CO., Waverley, Mass.

NEW YORK FLORISTS' CLUB.

The monthly meeting of this club on Monday evening, 13th inst., was a rousing good one with 70 members present. There were addresses and committee reports galore, all of which drew out abundant oratory. One particularly wise innovation was the appointment of a committee to supply honest information to the Associated Press to help correct the misleading reports on matters of horticultural interest which so often find their way into the daily papers. Alex Wallace and C. H. Totty were given this duty. Resolutions of thanks were passed to the Agricultural Department at Washington and a committee to prepare resolutions of condolence on the death of the daughter of James Dean was appointed. Outing committee and transportation committee both reported satisfactory progress. News from the sporting contingent was inspiring. It was announced that Thum's Alleys, Broadway and 31st street, would be the scene of the practice games every Friday night henceforth. A Ladies' Night has been decided upon and the date fixed as Wednesday, May 27. Special attractions will be provided and the entire evening will be given up to festivities. S. A. F. President Traendly made a fine address on the duty of the members to the National Society and the importance of the work mapped out for this year by the S. A. F. executive board at its recent meeting in Niagara Falls. W. A. Manda also made an interesting talk on the approaching centennial at Ghent, Belgium, and the great exhibition which would signal-

ize that event. Timely remarks were also made by Secretary Young and Robert Simpson.

The exhibition comprised Roses Newport Fairy from Julius Roehrs Co., Apple Blossom from A. Schultheis, Cherokee from W. A. Manda, Richmond from K. M. Schultz, Mrs. Jardine from Rob't Scott & Son, My Maryland and seedling 267 from John Cook; carnations Lloyd and Jahn's Crimson from H. A. Jahn, New Bedford, and a new hardy pink from W. A. Manda.

A NOTED BULB GROWER.



Martial Bremond, Ollioules, France

MORRIS COUNTY GARDENERS' AND FLORISTS' SOCIETY.

April 11th was "Rose Night" with this society and it was the best we ever had in attendance, quantity and quality of flowers, and in interest shown, although short in novelties. Visitors were here from New York, Newark, Orange, Chatham, and Rutherford. James B. McArdle made an address giving his impressions of the show which was highly complimentary. Harry A. Punyard's special cash prize of \$5.00 for best plant in flower, went to H. B. Vyse, gardener to A. R. Whitney, for a grand plant of Calceolaria hybrida. A 10-ft. tall specimen fuchsia from A. R. Kennedy, gardener to Dr. Leslie D. Ward, was greatly admired and a special cash prize of \$3.00 was awarded. A tempting dish of Telegraph cucumber from same grower was there. C. H. Totty had some nice plants of Azalea Bernard Andrae alba. Otto Koch, Morris Plains, had six fine pots of Spiraea Gladstone,—a cultural certificate; and for Spiraea Queen Alexandra he got a certificate of merit. Cultural certificates were given to A. C. Van Gaasbeck, John Dervan, grower for roses and antirrhinum, Villa Lorraine Roseries, F. P. Brigham, grower, Bride roses, Robert M. Schultz, roses, Florham Farms, A. Herrington, Supt., roses and tulips in pots, William Duckham, Richmond roses, John R. Mitchell, roses, C. A. Work, Wm. Muhl-michel, grower, Richmond roses, L. A. Noe, Joseph Ruizicka, grower, roses, John Green, Morristown, carnation seedling No. 1, scored 85 points, and secured a certificate of merit. His white seedling No. 2 scored 75 points. C. H.

THE BOSTON VIOLET

The people today are looking for New Violets just as much as they are for new roses or carnations.

THE BOSTON VIOLET

For the past two years has been placed before the most sceptical buyers in America and they prefer it to any other.

THERE'S A REASON

The Boston Violet is the largest, the most fragrant, it has a very pleasing color, and it is a great keeper.

THE BOSTON VIOLET

Is a variety that is early grown, it is the strongest grower and is in crop from September to May.

THE BOSTON VIOLET

Was awarded a First Class Certificate of Merit by the Massachusetts Horticultural Society and a Report of Superior Merit by the Gardeners' and Florists' Club of Boston.

Distribution will Commence in April. Order Now.

PRICES—\$2 per 12; \$12 per 100; \$100 per 1000.

WILLIAM SIM, : : CLIFTONDALE, MASS.

Totty had Azalea Bernard Andrae alba; vote of thanks.

John R. Mitchell read an essay on "The Rose" and received a rising vote of thanks therefor. A very interesting after discussion took place in which the following joined: Joseph Ruizicka, Wm. Muhlmichel, A. Herrington, R. M. Schultz, C. H. Totty, Wm. Duckham, J. A. Manda, A. R. Kennedy, and H. B. Vyse.

Next meeting May 13 will be devoted to flowering plants. Arthur Herrington will be essayist. This meeting will be "Ladies' Night." A refreshment committee has been appointed with Robert M. Schultz as chairman, which insures that the ladies will be well taken care of. Those wishing to remain during the entire session will participate in the spoils, for there will be then a general distribution of the flowers.

EDWARD REAGAN.

ST. LOUIS FLORIST CLUB.

The April meeting of the Florist Club took place in their new hall, eleventh and Locust streets, on last Thursday afternoon. The attendance was not as good as expected on account of the busy season being on.

Some important questions were to have come up but owing to the small attendance they were laid over until the next regular meeting in May.

The trustees on a full vote were instructed to report at the next meeting on the regular summer outing of the club, and the members present were all in favor of a boat picnic this year. This will be decided at the next meeting. There was a discussion on East-

ter stock. Reports from these present indicated that all were in good shape, some being afraid that stock would be too far advanced owing to Easter coming so late this year. Lilies are all in fair condition with 30 per cent. diseased.

President Young urged a better attendance for the May meeting, which takes place Thursday afternoon, May 14th, in the same hall.

CONNECTICUT HORTICULTURAL SOCIETY.

The regular meeting of this society was held in County Building, Hartford, April 10, Pres. Huss occupying the chair. It was Carnation Night and as invariably happens on such an occasion there was a large attendance of members. The quality of the exhibits as a whole was of a high order and the awards made in each case were entirely merited. The judging committee, Messrs. Zuger, Roulber and Chambers, went over the exhibits carefully and made the following awards: John Coombs, diploma for vase of White Perfection; Carl Peterson, certificate of merit for collection of carnations; W. N. Shumway, honorable mention for pink seedling; C. Peterson was also given honorable mention for a vase of Kaiserin roses.

H. A. Pinney, carnation grower for John Coombs, read an able and instructive paper on the history of the carnation, and was tendered a hearty vote of thanks. Pres. Huss complimented Mr. Pinney by saying that the paper was the most interesting he had ever had the pleasure of listening to.

G. W. Smith, of Melrose Farm, dele-

gate from this society to the annual meeting of the Massachusetts Fruit Growers' Association, gave a very interesting account of his visit.

The society will hold a Pansy Exhibit May 27, and a paper on the Evolution of the Pansy will be read by John Gerard.

The special committee reported having engaged Unity Hall for Sept. 23 for the Dahlia Show. A committee was appointed to secure a hall for the Chrysanthemum Show on Nov. 5-6. There will be an exhibit of roses at the meeting of April 24.

ALEX. CUMMING, JR., Secy.

CLUB AND SOCIETY NOTES.

The annual banquet of the Florists' Club of Washington, tendered to the retiring and the incoming officers was held on April 7 at Freund's. The tables were lavishly decorated. Joseph R. Freeman was toastmaster. Prof. Charlemagne Koehler was elected honorary member. Retiring president Bisset was presented with a handsome silver fruit dish. W. F. Gude making the presentation speech.

The thirteenth annual dinner of the Dutchess County Horticultural Society was held on April 2 at the Nelson House, Poughkeepsie, N. Y., with over a hundred in attendance. The carnation was the flower of the evening, each guest wearing one. Popular songs followed the feast and an address by the president and witty responses to the toasts proposed by Frank Hasbrouck, toastmaster, by A. Lee Wager, M. Heermance, Walter Price and G. V. L. Spratt, made a delightful occasion.

Aster Seed!! Have You All You Need??

If you still have an order to send:—DO NOT DELAY, SEND IT TODAY. We are now sold out of our Special Giant Comet. Some of the other varieties are almost sold out. All seed grown by us in 1907.

Aster Book and Competition Card for Great Aster Growing Contest, Free.

ALTIMO CULTURE CO., = CANFIELD, OHIO

Thorburn's Seeds

Seeds of ASPARAGUS PLUMOSUS NANUS, \$2.00 per 1000.
 Seeds of ASPARAGUS PLUMOSUS ROBUSTUS, \$2.00 per 1000.
 COLD STORAGE LILY OF THE VALLEY PIPS
 JAPAN LILIES, JAPAN IRIS

For prices, state quantities required.

J. M. THORBURN & CO.
 33 Barclay St., through to 38 Park Place
 NEW YORK

Best Quality Fall Bulbs

It is to your advantage to place your order early. Send us a list of your wants and we will quote you rock-bottom prices. Copy of our Florists' Bulb Catalogue will be sent upon request. Catalogues now ready.

VICK'S SUPERB PANSY SEED

All the best varieties in separate colors
 VICK'S SUPERB MIXTURE

the best strain from all the leading named sorts
 1-8 oz. 75c. 1-4 oz. \$1.50 Ounce \$5.00

JAMES VICK'S SONS, Rochester, N. Y.

FISKE SEED CO.

can supply new, to the florist for immediate use, fresh seed

Aster Seed A Specialty

Special Florist List Free

H. E. FISKE SEED CO.
 12 & 13 Faneuil Hall Square, BOSTON, MASS.

Prices quoted in these columns are for Dealers Only. When writing to Advertisers Please Mention HORTICULTURE.

QUALITY SEED BULBS PLANTS

SEND FOR CATALOGUE.

ARTHUR T. BODDINGTON

342 West 14th St., New York.

LANDRETHS' SEEDS

ONION SEED	EXTRA EARLY RED FLAT	LOW PRICES ON APPLICATION
	RED WETHERSFIELD DANVERS GLOBE STRASBURG YELLOW PRIZE TAKER	

BLOOMSDALE SEED FARMS, Bristol, Penna.

C. C. MORSE & CO.

Address all communications to our permanent address
 48 to 56 Jackson St., San Francisco, Cal.

The Largest Seed Growers in the United States

BRECK'S SEEDS

For Farmer, Market Gardener and Florist
 New Crop High Grade
 Catalogues mailed free on application

Joseph Breck & Sons Corp.
 47-54 NO. MARKET ST., BOSTON, MASS.

C A U L I F L O W E R S C A B B A G E S E E D

HJALMAR HARTMANN & CO.,
 12 Stormgade,
 COPENHAGEN, DENMARK.

Burpee's Seeds

PHILADELPHIA

Blue List of Wholesale Prices mailed only to those who plant for profit.

BRASLAN SEED GROWERS CO.

GROWERS FOR THE
 WHOLESALE TRADE ONLY
SAN JOSE, - - CALIFORNIA

RELIABLE SEEDS

SOW NOW

Ageratum Mexicanum Blue Star—
 Tr. Pkt. 25c. 6 Tr. Pkts., \$1.25.
Lobelia Erinus Pendiculata Hamburgia
 Tr. Pkt. 30c. 6 Tr. Pkts., \$1.50.
Primula Obconica Grandiflora—
 New Hybrids: Blood-red, Blue, Carmine, Pink, Purple, Violet, Pure-white, Compacta, Gigantea, Fringed Mixed Hybrids, each separate,
 Tr. Pkt. 50c. 6 Tr. Pkts., \$2.50.

My Catalogue will guide you through Reliable Seeds.
 Ask for Same.

O. V. ZANCEN
 SEEDSMAN, HOBOKEN, N. J.

Vegetable and Flower **SEEDS**

Reliable and Tested. Catalogue Mailed Free

WEEBER & DON
 Seed Merchants
 114 CHAMBERS STREET
 NEW YORK

JUST ARRIVED LARGE SHIPMENT OF High-Grade SCOTCH SOOT.

We have the Stott Double Nozzle
THOMAS J. GREY CO.
 32 & 33 So. Market St., BOSTON

BRIDGEMAN'S SEED WAREHOUSE RICKARDS BROS.

Props.
 37 East 19th St., - NEW YORK CITY

BAMBOO CANES TOUGH AND STRONG

6 ft. long—\$1 per 100; \$6 per 1000; \$11 per 2000

They cost about 10 per cent. more than other kinds, and they are 10 times better.

STUMPP & WALTER CO., - 50 Barclay St., New York

PLANT NOTES.

Chicago growers complain that many of the Dutch bulbs have proven very poor this year.

Plant growers report a largely increased demand each season, of late, for *Euphorbia Jacquinæflora*. Its adaptability as a Christmas cut flower is beginning to get recognition.

The pretty little blue *Saintpaulia ionantha* is not difficult to handle unless it gets too much water or too much sun. Moderate doses of each are more to its liking. It should be grown in quantity for jardiniere use.

A few vines of *Solanum jasminoides* allowed to grow overhead in the show house add greatly to the attractiveness and its pendant clusters of pure white flowers will be found useful in such work as mirror or mantel decoration. Its growth is not heavy enough to obstruct the light to any injurious extent.

At Lincoln Park conservatories, gardener Frey has been doing some crossing between *Cineraria stellata* and *C. hybrida*, the progeny possessing intermediate characteristics, combining the tall growth and airy gracefulness of the *stellata* and the large full flowers of the florists' hybrid strains and eliminating the heavy coarse habit of the latter.

The E. G. Hill Company are so conspicuous in the production of roses that their work in zonal geraniums is thrown into the shade. The visitor to the Richmond greenhouses will find, however, some very handsome seedlings blooming and among them one of the highest order of merit, which has been named Lucille. Among the imported novelties Col. Porter looms up as decidedly the most pronounced yellow scarlet yet produced. The seedling carnations at Mr. Hill's include several eye-openers.

PLANT IMPORTS.

From Antwerp: H. F. Darrow, 2 cs. plants; J. Dunn, 1 cs. do.; Maltus & Ware, 10 cs. do.; 6 cs. trees; 6 tubs do.; L. Patterson, 1 cs. plants; August Rolker & Sons, 15 cs. do.; J. Ter-Kuile, 1 cs. do.; Henry P. Turner, 1 cs. do.; Sundry Forwarders, 11 cs. do., 16 cs. shrubs, 304 tubs laurel trees.

From Rotterdam: Cleary's Horticultural Co., 6 cs. plants; Wm. Elliott & Sons, 22 cs. do.; R. F. Lang, 3 cs. do.; McHutchison & Co., 1 cs. do.; P. Onwerkerk, 63 cs. trees; F. R. Pierson & Co., 7 cs. do.; C. B. Richard & Co., 26 cs. do.; A. Rolker & Sons, 10 cs. plants; Orlando J. Smith, 31 pgs. do.; J. M. Thorburn & Co., 3 bgs. garden seed; Vaughan's Seed Store, 4 cs. trees and shrubs; Wadley & Smyth, 11 cs. plants; Sundry Forwarders, 3 cs. trees, 117 pgs. plants; 3 cs. do.

MOVEMENTS OF GARDENERS.

Alex. C. Fraser, formerly with R. C. Hooper, W. Manchester, Mass., is now located at Napanoch, N. Y.

George Dunnean, recently at Wild Garden, Brookline, is on the Lester Leland estate at W. Manchester.

James Rust has left Roughwood, Chestnut Hill, Mass., and taken a position with Philip L. Saltonstall, Hyde Park, Mass.

FIRE RECORD.

An overturned lamp did considerable damage to the office of F. B. Fountain, Middletown, Conn., last week.

J. T. Temple of Davenport, Ia., recently sustained a loss of about \$300 from a fire that started in a brush heap.

B. B. Smalley and Mrs. C. B. Magee were both burned out, losing everything in the great fire at Chelsea, Mass., on April 12.

Allen Wheeler, Hutchinson, Minn., lost his greenhouse by fire and many of the plants that were saved were killed by the frost.

Greenhouses owned by James Weir & Son, Fifth Ave. and 68th St., Brooklyn, N. Y., were set on fire April 2, probably by boys. Loss \$50.

Looking for a leak in the gas pipe with a lighted match caused an explosion in the store of E. Feldman, 1147 Broadway, Brooklyn, N. Y., on April 10. Fortunately the damage was slight.

The office and workrooms of Clark Bros., Providence, R. I., were destroyed by fire which started near the stove, on April 4. The big greenhouses were saved by the valiant efforts of the firemen.

MISSOURI BOTANICAL GARDEN.

At a meeting of the board of directors and the trustees of the Henry Shaw estate the past week it was decided on an outlay of \$500,000 to erect seven buildings. The undertaking embraces the founding of the finest herbarium in the world. The idea was conceived by Prof. Wm. Trelease, director of the Missouri Botanical Garden ten years ago as set forth in his eighth annual report to the trustees. Prof. Trelease says the plan will be carried out. He declared that the collections were increasing at such a rate that the building would not be adequate within a few years. The collection which, soon after the death of Mr. Shaw in 1889, numbered 160 specimens, now has more than 500,000. The present buildings are overcrowded and sufficient space cannot be given for display.

DURING RECESS.

The bowlers of the New York Florists' Club, inspired by Mr. Traendly's tempting offer of free transportation to the Niagara Falls convention for the five making the highest record above a certain figure, have taken hold of the practice games in earnest. The following list, with their scores for two games as recorded last Friday evening tells the story.

Marshall	353	Young	289
Fenich	331	Traendly	272
Manda	329	A. Rickards	272
W. Rickards	319	Totty	256
Duckham	310	Shaw	216

OBITUARY.

Lawrence J. Stuppy of St. Joseph, Mo., died suddenly on March 30. He has lived in St. Joseph since 1851, and started in the flower business there in 1873. A widow and six children survive him.

BUSINESS CHANGES.

Fred Eberle has bought the business of Daniel Malie in the North Side market, Pittsburg, Pa.

I. P. Herzog succeeds R. A. Mason & Co., at Cadillac, Mich., he having bought out the business.

James M. King, 198 Tremont street, Bronx, New York, has taken C. H. Wainwright into partnership.

R. and H. Cook of New Orleans, have dissolved partnership and Reinhard will open a place on Scott street.

William Walker, Louisville, Ky., has opened a branch store on Jefferson street, between Third and Fourth streets.

Sidney Clark of Menlo Park, will soon remove to Elmhurst, Cal., where he has taken a lease of the Fromenweiler place.

Alfred G. Lozier, Des Moines, Iowa, has leased the store at 518 Walnut street, and will begin at once on the improvements necessary to make it a model flower establishment.

The Kemble Floral Co., has bought Lyons Park, Mason City, Iowa, and it is their intention to erect a range of houses and move from West Fourth street as soon as they are completed, which will probably be by September first. L. E. Flindt is local manager.

The Bell Floral Co., succeeds to the business of W. T. Bell & Sons, and among the changes contemplated will be the removal of the greenhouses from Franklin, Pa., to Niles, although a flower store and a stock of seeds will be maintained at Franklin. John, Edward and Philip Bell comprise the new firm.

KILLARNEY'S CHICAGO HOME.

Weiland & Reisch will build an addition to their range of houses. The work was begun this week and while it is not yet decided just how large the addition will be, it is certain that not less than one hundred thousand square feet of glass will be used. This extensive addition will be used for roses, Killarney leading.

Weiland & Reisch were the first western growers to cultivate Killarney. It was tried by American florists with many misgivings and very little success, but Weiland & Reisch had faith in it and today Killarney is its own witness to the foresight and perseverance of Weiland & Reisch. Today there are ten times as many Killarneys as Beauties sold in Chicago, though it never will take its place. It is a more generally becoming shade of pink than Bridesmaid for the corsage bouquet. Although exceedingly hard to propagate (being a very free bloomer it does not make hard enough wood for propagating), its cultivation is rapidly increasing and would even faster if stock could be secured. Mr. Weiland thinks it the greatest seller in Chicago today.

WIV send away for worthless dry bulbs when you can gain time and save money by buying at home. **Cannas all started for \$2.00 per 100.** Austria, Robusta, Pennsylvania, Italia, Chas. Henderson, Mille, Berat and Pres. Carnot.

J. B. SHURTLEFF & SON,
Cushman Ave., Revere, Mass.

ORCHIDS

We advise the growers and private places that our importations will begin to arrive in a few weeks time and we will have the following :

- C. gigas, C. Mendelii, C. Schroederae
- C. Aurea, Miltonia Vexillaria
- C. Trianae, C. gigas Sanderiana C. Mossiae, C. Speciosissima
- C. Gaskelliana, C. Percivaliana C. Labiata and others.

Therefore we give our customers the advantage of the special sale of two kinds of plants for fifteen days. Strong, healthy, established C. PERCIVALLIANA in blocks, 1 1-2 yds long and 20 ins. wide, containing no less than two doz. plants at \$6.00 each. Pots from 7 to 10 bulbs at 60c. Pots from 10 to 15 bulbs at 80c.

C. SPECIOSISSIMA, from 7 to 10 bulbs at 60c., from 10 to 15 bulbs at 80c.

We guarantee that our plants will be extra fine with no disease or Cattleya fly and will quote the lowest prices in America.

ORDONEZ BROS., : Madison, N. J.

EASTER LILIES

"Yes! We've Got 'Em"

FINE STOCK

SEND ORDERS IN EARLY

SELECT \$15.00 per 100
MEDIUM 12.50 " "

Write for prices on large quantities

MIAMI FLORAL CO.

DAYTON - - - - OHIO

Extra good value in

Decorative Plants

Azaleas, Kentias, Rubbers, Arecas
Araucarias, Pandanus, Box Trees,
Euonymus, Crotons, and
Eurya latifolia.

A Leuthy & Co.

Perkins Street Nurseries, Roslindale, Mass.

HYACINTHS, TULIPS, NARCISSI AND OTHER BULBS

ROMAN HYACINTHS and the true
PAPER WHITE GRANDIFLORA

Ask for our Wholesale Trade List at Hillegom

K. VELTHUYS, Hillegom, Holland
Rep. by FEL X BOSCH, 260 Clarendon St., Boston.

ORCHIDS

We are at present booking orders for freshly imported Orchids for delivery 1908, of all leading kinds at reduced prices. We have just received the following: Oncidium Sarcodes, O Forbesii, O Tigrinum and Sophronites, Grandiflora and Coccinea.

LAGER & HURRELL, Summit, N. J.

ORCHIDS

Largest Importers, Exporters, Growers
and Hybridists in the World

Sander, St. Albans, England
and 235 Broadway, Room 1
NEW YORK CITY

ORCHIDS

Arrived in superb condition, a magnificent consignment of Den Formosum giganteum, D. Wardianum. These are indeed fine plants. Will arrive April 15. C. labiata, C. Trianae, C. gigas Sanderiana. To arrive about May 1 to 15. C. Mendelii, C. Schroederae, Mossiae, Gaskelliana, Percivaliana. A trial order will prove we carry the best stock that can be secured.

CARRILLO & BALDWIN Secaucus, N. J.

Imported Orchids JUST TO HAND

Laelia Purpurata
Cattleya Intermedia
Cattleya Mossiae
JULIUS ROEHRS CO.,
The Orchid Nurseries RUTHERFORD, N. J.

ORCHIDS for Spring Delivery

NEW IMPORTATIONS
Cattleyas, Laelas, Oncidiums, etc.
WRITE FOR PRICES
Now is the time to Pot Orchids. Best Quality
of Peat, Moss and Barklets on hand.
JOSEPH A. MANDA, 191 Valley Road,
WEST ORANGE, N. J.

FERNS

Boston, 4 inch 12c, 5 inch 25c.
Pierstonii, 3 inch 8c.
Elegantissima, 2 1/4 inch 6c, 3 inch 10c,
4 inch, 15c.

BAUR FLORAL CO. Erie Pa.

NEPHROLEPIS SCOTTII

in the following sizes, extra good value
25c., 50c., 75c. and \$1
Grand Specimen Plants at \$3, \$4, \$5, \$6.

JOHN SCOTT
Rutland Road and E. 45th St.
Tel 2890 Bedford BROOKLYN, N. Y.

NEP. WHITMANI

2 1/4 in., \$5.00 per 100

NEP. WHITMANI

3 1/2 in., \$25.00 per 100

BOSTON FERNS

2 1/4 in., \$3.00 per 100

H. H. BARROWS & SON Whitman, Mass.

Ipomoea Noctiflora

Best pure white moonvine in market, very fragrant and as big as a saucer. On this variety we have a world-wide reputation as growers and shippers for the last twenty years. Price, 2 1/2 in. pots, \$5.00 per 100. 10,000 are now ready.

CODFREY ASCHMANN,
1012 W. Ontario St., Philadelphia, Pa.

JAPANESE
THE YOKOHAMA NURSERY CO. NEW YORK.
31 BARCLAY STR.
LILIES
PLANTS
BAMBOO STAKES

JOHN BREITMEYER'S SONS

Cor. Miami and Gratiot Aves.
DETROIT, MICH.

Artistic Designs . . .
High Grade Cut Blooms

We cover all Michigan points and good
sections of Ohio, Indiana and Canada

William J. Smyth FLORIST

Cor. Michigan Ave. and 31st St., CHICAGO
We ship to all points in Illinois and Iowa.
Phones: Douglas 744, Douglas 523, Douglas 740

M. C. and J. E. HAUSWIRTH

232 Michigan Ave.
CHICAGO
AUDITORIUM ANNEX Tel. Harrison 585

SAMUEL MURRAY Florist

Coates House Conservatory
1017 BROADWAY, KANSAS CITY, MO
Both 'Phones 2670 Main

FRED C. WEBER FLORIST

4326-28
OLIVE STREET ST. LOUIS, MO.
Established 1873
Long Distance Phone Bell Lindell 676



WASHINGTON,
D. C.

GUDE'S

Geo. H. Cooke FLORIST

Connecticut Avenue and L Street
WASHINGTON, D. C.

The Park Floral Co.

J. A. VALENTINE
Pres.

DENVER, COLORADO

WILLIAM L. ROCK FLOWER CO.

KANSAS CITY, MO.

will carefully execute orders for Kansas City
and any town in Missouri or Kansas.

Of Interest to Retail Florists.

Caroline E. Scallen, florist, 1242 Broadway, New York, has filed a petition in bankruptcy; liabilities, \$8,303; assets, \$531.

F. L. Zeigler of Newport, R. I., held an opening of his Bellevue avenue store on April 9, and presented floral souvenirs to all patrons.

D. William Brainard, Thompsonville, Conn., held his annual Easter display from Wednesday to Saturday, April 5-18, with a fine array of tempting stock.

H. R. Hughes of Chicago, who is the most original and ingenious advertiser in the retail florist business, has issued a folder for Easter, 1908, showing illustrations of some of his unique window decorations.

We fail to see anything attractive or appropriate in the "Armadillo baskets" offered as a novelty for florists' use this season. With so much pretty material available for basket making as evidenced in the stock to be seen in an establishment such as Bayersdorfer's, for instance, there is no need to use such "creepy" things as flower receptacles.

No rose is better liked by the J. M. Gasser Company than Gen'l MacArthur and they carry it as a regular stock all winter. Grown as they grow it, with cool treatment, it is strong and healthy almost beyond belief and is a big producer. Its bright crimson color and unrivalled fragrance make this rose very popular and it deserves more general attention from the growers.

DETROIT Business is quiet, but considering the many bookings of Easter orders so far reported we can truly say it is the ominous quiet before the storm. May it storm good and hard, because many a cash drawer is parched badly and needs a heavy soaking. Most of the stores are beginning to put on the holiday dress.

NEW RETAIL FLOWER STORES.

F. X. Dienst, Middletown, N. Y.
Edward Stelzig & Son, Bellefontaine, O.

Desire Corbin, 40th & Market streets, Philadelphia.

Mrs. Moir, branch store, Snow Block, Brockton, Mass.

Gammage & Sons, Chatham, Ont., and Petrolia, Ont.

Signal Hill Floral Co., Los Angeles, Cal., 206 W. 4th St.

J. R. Sederquest, St. Stephen, N. B., has taken a larger and better equipped store on Water St. and will have an attractive exhibit of Easter plants and flowers. He has outgrown his former quarters.

F. L. Drake has the contract to furnish the geraniums for planting at the soldiers' graves on Memorial Day in Pittsfield, Mass.

Florists Out of Town

Taking orders for delivery in
New York or Vicinity
can have them filled in best
manner and specially deliv-
ered by * * *

Thomas Young, Jr.

500 Fifth Ave., New York City
Telephone 847 Bryant.

ALEX. McCONNELL

571 FIFTH AVENUE
NEW YORK CITY

Telegraphic orders forwarded to any part of the United States, Canada, and all principal cities of Europe. Orders transferred or intrusted by the trade to our selection for delivery on steamships or elsewhere receive special attention.

Telephone Calls, 487 and 488 38th St.
Cable Address, ALEXCONNELL

WILLIAM H. DONOHUE

FLORAL DECORATOR
17 East 28th St., New York
Special Attention to Theatre
and Steamer Orders, and reliable
deliveries guaranteed.

DAVID CLARKE'S SONS

Deliver orders from any part of the country to
New York City
Or OUT-GOING STEAMERS
Write or telegraph
2139-2141 Broadway, New York
Telephone 1552-1553 Columbus

M. A. BOWE

In the Heart of New York City
1294 Broadway
Tel. 2270, 38th St. NEW YORK
Our Motto -- The Golden Rule.

YOUNG & NUGENT

42 West 28 St., NEW YORK
"FLOWERS BY TELEGRAPH"

Flower Deliveries

In Brooklyn and other Long Island Points
New York City, New Jersey, etc. At Theatres,
Hotels, Steamers or Residence-s.

WILSON

Fulton St. and Greene Ave., Brooklyn, N. Y.
ALBANY, N. Y.

EYRES

Flowers or Design Work
DELIVERED IN ALBANY AND VICINITY
ON TELEGRAPHIC ORDER.

11 NORTH PEARL ST., ALBANY, N. Y.

JACOB SCHULZ, 644 Fourth Ave.,
LOUISVILLE, KY.
Cut Flowers of BEST QUALITY in season
delivered promptly to any address.
Write, Telegraph or Telephone.
Cumberland and Home Phones 223 and 984

PROMPT DELIVERY IN BOSTON

AND ALL NEW ENGLAND POINTS
HOUGHTON & CLARK
396 Boylston St., Boston, Mass.



BOSTON'S BEST In Quality and Design

Can be relied upon when you transfer your retail orders to

EDWARD MACMULKIN
194 Boylston Street, Boston

Send flower orders for delivery in
BOSTON
and all
NEW ENGLAND POINTS
THOS. F. GALVIN
124 Tremont St., Boston

TRANSFER
Your orders for flower or plant delivery in Eastern New England to
JULIUS A. ZINN,
2 Beacon St., Boston.
Fine Design Work a Specialty

YALE Orders for flower deliveries to Yale College and all other Connecticut points carefully filled and delivered by
J. N. CHAMPION & COMPANY
1026 CHAPEL STREET NEW HAVEN, CONN.

Chicago. Established in 1857

WITTBOLD FLORIST
1657-1659 Buckingham Place
L. D. Phone 558 Lake View. Send us your retail orders. We have the best facilities in the city.

The Far-Famed Flowers of
TORONTO
Delivered on mail or telegraph order for any occasion, in any part of the Dominion.
JOHN H. DUNLOP,
96 Yonge St., Toronto, Ont.

ATLANTA FLORAL CO.
41 Peachtree Street, ATLANTA, GEORGIA.

ROBERT J. DYSART,
Public Accountant and Auditor
Simple methods of correct accounting especially adapted for florists' use.
Books Balanced and Adjusted
Merchants Bank Building
28 STATE ST., BOSTON
Telephone, Main 38

HART'S HANDY HANDLE

"At Easter-time, with a little chiffon decoration, and the Handle, we were able to increase the value of plants from 50% to 100%."—H. E. WILSON.

Write for descriptive circular and prices

GEO. B. HART, 24 Stone St., Rochester, N. Y.



EVERY FLORIST NEEDS IT Lewis's Weekly Board File

takes the place of Memo or Order Books, or a line of nails. Just the thing for Sales Slips, Orders to be filled, etc. The Board File is made up of sets of our Spring Spindle File as illustrated herewith. Among the prominent Florists now using it are:

H. H. Ritter, Dayton, O.; W. C. Stickle, Pres. Park St. Flower Market, Boston; Edw. Wood, Pres. Music Hall Flower Market, Boston; J. C. Hatcher, Amsterdam, N. Y.; F. S. Follweil, Pittsfield, Mass.; I. L. Powell, Milbrook, N. Y.; Kensington Flower Shop, Boston; T. F. Galvin, Boston, Mass.

50,000 In Use.

See Large Ad. Horticulture, page 504, April 11, 1908.

A. F. LEWIS MFG. CO., E. Boston, Mass.

NEWS NOTES.

Reynolds & Struck have started in the florist business at Buechel, Ky. Mr. Reynolds was for a long time with the late C. H. Kunzman.

McHutchison & Co. have been appointed sole agents for United States and Canada for Royal Tottenham Nurseries, Deedemsvaart, Holland.

The Park Commission of Detroit is exhibiting a choice collection of some 2000 calceolaris in 6 in. and 7 in. pots which are greatly admired by the public.

Fred Schmidt has left his employment as foreman of the Newberry estate and will start greenhouses near the Woodlawn Cemetery, Detroit. Thos. Evans, of Marshalltown, Ia., has succeeded to his position.

Upon petition, Irwin W. Coy has been appointed receiver to close up the business of the Calla Cut Flower Co., Youngstown, O. C. W. Hendricks, the plaintiff, asks that the property be sold and the proceeds used to settle the indebtedness.

Carl Meier of Green Bay, Wis., is having a plate glass front put into his office, and the room remodelled so that there will be more display space for his stock. He will make more of a feature of the wholesale end of the business hereafter.

Joseph Fuller, of Leominster, Mass., recently found that glass had been broken in the rear door of his greenhouse and some carnations were missing. Lawrence Serio was arrested and made confession. He was sent to the House of Correction.

Florists who have found it difficult to get a reliable, durable greenhouse hose should try the "Sunnywoods" brand, offered by Frank L. Moore in our advertising columns. Mr. Moore is a florist himself, and knows the requirements for a serviceable hose.

J. W. Davis of the Davis Market Garden Co., has purchased the Hall farm at So. Meriden, Conn., and will

at once put it in condition for vegetable raising. A range of houses will be built for winter vegetable forcing and a house for growing violets and carnations.

DETROIT'S GOOD EXAMPLE.

A movement which will do much to bring the florist and nurseryman's services into more prominence has been started by the City Service League of Detroit, Mich. This is a new branch of the local Board of Commerce. Its principal aim is to interest the householder in the improving of his or her little yard. On the afternoon of April 11 a public meeting was called in the Detroit Opera House and the place was crowded with men and women. Several very prominent men spoke on the need of general improving and in particular of improving front and back yards. To further stimulate the work prizes of \$75, \$50 and \$25 respectively were offered for well arranged yards, as also a special prize of \$50 for the best appearing district.

BOSTON FLORIST LETTER CO. Manufacturers of FLORISTS' LETTERS

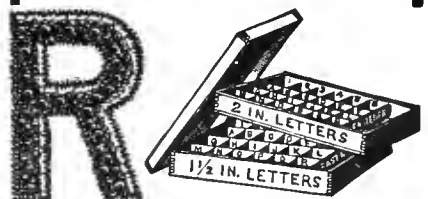

This wooden box nicely stained and varnished, 18x30x12, made in two sections, one for each size letter, given away with first order of 500 letters

Block Letters, 1 1/2 or 2 inch size per 100, \$2.
Script Letters, 3. Fastener with each letter or word. Used by leading florists everywhere and for sale by all wholesale florists and supply dealers

N. F. McCARTHY, Manager
66 Pearl Street, BOSTON, MASS.

KORAL SCRIPT LETTERS AND EMBLEMS

ONCE USED ALWAYS USED
For sale by all first class supply houses. Made by
KORAL MFG. CO.
26 Hawley St., Boston

For After Easter Weddings we offer

CHOICE VALLEY
S. PEAS, Long Stems
CATTLEYS CUT LILIES

The Leo Niessen Company
 1209 Arch St., Philadelphia, Pa.
 Open from 7 a. m. to 8 p. m.

For After Easter Weddings

CHOICE VALLEY, \$3 and \$4 per 100
GARDENIAS, \$2.50 and \$3 per doz
SWEET PEAS, 75c. and \$1 per 100

S. S. PENNOCK - MEEHAN CO.
 1608-1620 Ludlow St. PHILADELPHIA
 "The" Wholesale Florists of Philadelphia

EVERYTHING SEASONABLE IN
CUT FLOWERS
 EDWARD REID, Wholesale Florist
 1526 Ranstead St., PHILADELPHIA
 STORE CLOSES 8 P. M.

CUT FLOWER BOXES
 EDWARDS FOLDING BOX CO
 MANUFACTURERS
 PHILADELPHIA, PA.

CHAS. W. MCKELLAR

51 WABASH AVE., CHICAGO

Western Headquarters for Choice Orchids
 Valley, Roses and all Cut Flowers

J. B. Murdoch & Co.

Wholesale Florists
 FLORISTS' SUPPLIES

714 Penn Ave., PITTSBURG, PA.
 Long Distance Phone 1435 Court.

AMERICAN BEAUTY and all other
ROSES
LILY OF THE VALLEY, CARNATIONS
WELCH BROS., 226 Devonshire St., Boston, Mass.

Choice Kaiserins

\$4, \$8 and \$12 per 100

W. E. McKISSICK WHOLESALE FLORIST
 PHILADELPHIA
 1619-1621 RANSTEAD ST.

DAILY CONSIGNMENTS

From 40 to 60 Growers

We can care for your cutflower wants to advantage.

E. F. WINTERSON CO.
 45-47-49 WABASH AVE., CHICAGO

Rice Brothers

115 N. 6th Street, MINNEAPOLIS, MINN
WHOLESALE FLORISTS and SUPPLIES
 CUT FLOWERS received twice daily, and can fill your orders to your satisfaction. A complete line of Hardy Greens - WILD SMILAX, BOXWOOD, HARDY FANCY FERNS, GALAX LEAVES.
 Write for quotations on large quantities.

H. BAYERSDORFER & CO.
 The Florists' Supply House of America

Send for Illustrated Catalogue
 1129 ARCH ST., PHILA., PA.

Alex Mann, Jr. Co., Inc.
 Wholesale Dealer in
 Florists' Supplies and Cut Flowers
 White Doves, \$9.00 per doz.
 Galax Leaves.
 1125 Polk Street, San Francisco, Cal.

WHOLESALE FLOWER MARKETS—TRADE PRICES—Per 100 TO DEALERS ONLY

	CHICAGO April 16	TWIN CITIES April 14	PHILA. April 13	BOSTON April 16
ROSES				
Am. Beauty, Fancy and Special..	30.00 to 40.00	40.00 to 50.00	25.00 to	20.00 to 35.00
" Extra	25.00 to 30.00	30.00 to 40.00	15.00 to 20.00	15.00 to 20.00
" No. 1	20.00 to 25.00	15.00 to 25.00	12.00 to 15.00	6.00 to 10.00
" Lower grades	5.00 to 15.00	8.00 to 15.00	2.00 to 8.00	4.00 to 6.00
Bride, 'Maid, Fairy & Special	8.00 to 10.00	0.00 to 15.00	6.00 to 10.00	6.00 to 8.00
" Extra and No. 1	5.00 to 6.00	8.00 to 10.00	5.00 to 6.00	3.00 to 5.00
" Lower grades	3.00 to 5.00	5.00 to 8.00	2.00 to 4.00	1.00 to 2.00
Killarney, Richmond, Fan & Sp.	0.00 to 10.00	9.00 to 12.00	15.00 to 20.00	6.00 to 12.00
" Lower grades	4.00 to 6.00	5.00 to 8.00	2.00 to 10.00	2.00 to 6.00
Chat'nay, Wellesley, Fan & Sp.	6.00 to 10.00	9.00 to 12.00 to	4.00 to 8.00
" Lower grades	4.00 to 6.00	5.00 to 8.00 to	1.00 to 3.00
Golden Gate Ivory	3.00 to 10.00	8.00 to 10.00	2.00 to 8.00	1.00 to 6.00
CARNATIONS				
Fancy and Novelties	4.00 to 5.00	5.00 to 6.00	2.00 to 4.00	3.00 to 4.00
Ordinary	2.00 to 3.00	4.00 to 5.00	1.00 to 2.00	2.00 to 3.00
MISCELLANEOUS				
Violets50 to .75	.75 to 1.25	.40 to .75	.75 to 1.00
Cattleyas	50.00 to 60.00 to 50.00	60.00 to 75.00	50.00 to 60.00
Cypripediums to to to	8.00 to 10.00
Lilies	12.50 to 15.00	12.50 to 15.00	6.00 to 12.00	6.00 to 10.00
Lily of the Valley	3.00 to 5.00 to 4.00	2.00 to 4.00	1.00 to 3.00
Daistes	1.00 to 2.00	1.00 to 2.50	.50 to 1.00 to
Daffodils to 3.00	3.00 to 4.00	2.00 to 3.00	.50 to 1.50
Tulips	2.00 to 4.00	4.00 to 6.00	1.00 to 3.00	.50 to 1.50
Mignonette	35.00 to 50.00	40.00 to 60.00	5.00 to 20.00	25.00 to 40.00
Gardenias to	1.50 to 2.00 to	1.00 to 1.50
Lilac per bunch50 to 1.50	.75 to 1.25	.50 to .75	.25 to .50
Sweet Peas	75 to 1.00 to 1.50	1.00 to 1.50	1.00 to 1.50
Whitmanii Fronds to to	3.00 to	2.00 to 3.00
Smilax	15.00 to 20.00	12.00 to 18.00	20.00 to 25.00	10.00 to 12.00
Asparagus Plumosus, strings	35.00 to 50.00	35.00 to 40.00	50.00 to 75.00	25.00 to 50.00
" " & Soren (100 bchs)	25.00 to 35.00	35.00 to 40.00 to	1.00 to 2.00

J. A. BUDLONG

37-39 Randolph Street, CHICAGO.

Roses and Carnations WHOLESALE CUT FLOWERS
 A Specialty..... BROWER of

E. A. BEAVEN
 Southern Wild Smilax,
 Log Mosses,
 Natural and Perpetuated— at Wholesale,
 EVERGREEN, ALABAMA.

The best Fancy and Dagger Ferns on the Market. For Easter, \$1.50 per thousand. Guaranteed.

H. J. SMITH
 HINSDALE - - MASS.

FLOWER MARKET REPORTS

BOSTON The rising tide of the Easter trade finds everybody well prepared for the rush. Stores are well supplied with a stock of plants of quality never excelled and the prospects are for an equally high grade supply of all flowers. The movement of the latter to outside points has already begun and the situation promises well, three days before the holiday. There is a good demand for high-colored carnations and violets are especially in favor. Roses are moving slowly at very little or no advance over prices heretofore prevailing, and all the wholesalers are able to do is to keep the stock moving at normal rates. There is an overstock of greens; smilax is not going as in other years; lily of the valley and bulbous stock generally finds a very slow market; lilies cut and on plant are selling well and a sale for the entire product is already assured. It is generally accepted that Easter trade in New England territory will be no less in volume than that of a year ago. Considering the business depression of the past winter, weather not interfering, the prospects are exceedingly encouraging.

BUFFALO Market conditions have changed but slightly in the past two weeks; the supply has shortened so little as to be hardly noticeable, prices holding about the same as last reported. It has been a matter of forcing the stock upon buyers at prices exceedingly low. Beauties are plentiful as well as all other stock. The trade is in readiness for a good Easter rush, and it is hoped that this week's business will be a record breaker. The retailers' windows are full of blooming plants and the "Today only" bargain sign seems to have been laid away for the time being.

CHICAGO Easter trade so far is very gratifying to Chicago people. Conditions have proven about the same as they did at the holiday season. Everyone predicted in December that the financial depression would make trade very light, but when the holiday week was over the books showed satisfactory results. Many predicted one month ago that sales would be small for Easter. Some of the largest plant growers in Chicago had their benches empty two weeks before Easter or practically everything labelled "sold." Everywhere the stock is fine and brings in the much-coveted and necessary dollars.

Thousands of potted lilies, hydrangeas, rhododendrons, spirea and roses as well as ferns are being rapidly transferred from the growers' benches to the retail florists' counters. Azaleas are in good demand and the stock is very fine. Baby Ramblers are supplanting Crimson Ramblers as bush plants, though there are offered some fine trained specimens of the latter. In cut flowers stock is fine and just plentiful enough. Many of the retail stores are beautiful and business lively.

INDIANAPOLIS Business continues to be changeable. Some days stock is well cleaned up, then again trade drags. The rose and carnation crops have shortened up a bit, but the bulbous stock is coming in such large quantities that this is not noticed. The call for Beauties and long stemmed teas continues good. Carnations continue to bring a fair price. Stock everywhere is looking fine and the quantity denotes better than words can tell the expectations of a large Easter trade. Azaleas are very popular this year, especially the lighter shades. Certain sections report the lily crop light but probably no difficulty will be met with in securing ample supplies. Extensive supply of lily of the valley, sweet peas and orchids will be available and will be much used owing to the shortness of the violet crop. Boxwood and laurel trees are handled in large numbers by the leading retailers. There is quite a trade in smilax and other greens of which there is a good supply.

NEW YORK Trade is light in cut flowers, most of the interest, as usual previous to a holiday, being concentrated in plants, of which there is a splendid supply. Cut flower shipments are not so heavy as they have been. The lightening up may be due in part to the hoarding of the cut by some of the growers; time will tell. There is no disposition to unduly advance prices and those who need a supply for Easter use can be accommodated with excellent material at normal figures. The quality and extent of the flower demand will not be in evidence until Saturday afternoon.

PHILADELPHIA Tone of market slightly improved last week. Stocks moved out better and there were fewer losses. Price levels were not greatly changed. Sweet peas continue one of the healthiest stocks, with quality, quantity and demand in thorough harmony. Roses are in good supply and generally excellent as to quality. Kaiserins have now commenced from the dormant plants, and lead in whites as to size and quality. Carnations held a little firmer and cleared up in better shape. Southern daffodils are over and the market draws a big sigh of relief. There are some good local greenhouse flowers of these still com-

ing in. Double violets are fair—much better than the singles. The latter are nearly over for the season, locally. Lily of the valley is still sluggish. Orchids are on the short side. Lilies plentiful; enough for all Easter demands, but quality on an average is under standard. Gardenias plentiful and rather quiet. Plant market at this writing—Monday before Easter—seems to be dragging a little, except in fancy stocks, which have been pretty well picked up. Average stocks will no doubt have their innings as the days go by.

TWIN CITIES Prices have not varied any for the last week or two. Stock is plentiful, but not too much so. Violets are about gone. The Easter rush has commenced, at least with the wholesalers. Easter prices date from April 14. The prospects for a good Easter trade are very promising. Lilies, carnations, roses, azaleas, astilbes,—in fact almost everything is in splendid condition and ought to find a ready market.

EXHIBITION AT BALTIMORE.

The National Sculpture Show is in progress at the Fifth Regt. Armory. The exhibition is a great success in every way. The decorations consist of hundreds of large specimen palms and other exotics from the parks, private places and some of the local florists.

Messrs. E. A. Seidewitz and C. L. Seybold arranged the Italian parterre garden and the green effect is unquestionably the best that has yet been seen anywhere; this is the consensus of opinion of the sculptors and others that have seen the exhibition. Many wagon loads of palms, laurel, holly, spruce and cedar were used to complete the backing of the statuary. The Gardeners' Club of Baltimore had intended to hold a spring show in conjunction with this exhibition, but being in the midst of Easter it had to be abandoned. Some of the florists and nurserymen, however, expect to place additional exhibits after the Easter holidays are over, as the exhibition will last over three weeks.

C. L. SEYBOLD.
Carroll Park.



Bostrom Improved Builders' Levels and Farm Levels

For Park, Cemetery and Landscape Gardening use, take the place of expensive Engineering Instruments. Simple in construction, easily adjusted, more substantial and less cumbersome than the more elaborate and complicated instruments. Practical, up-to-date instrument that any one can use. Write for descriptive circulars and be convinced that this Level is necessary to complete your outfit. Builders' Level \$25.00. Farm Level \$12.50.

BOSTROM-BRADY MFG. CO., 133 Madison Avenue, ATLANTA, GA.

The KERVAN CO. 113 W. 28th ST. New York

WHOLESALE DEALERS

Fresh cut Palmetto & Cycas Palm Leaves, Galax, Leucothoe, Ferns and Mosses. All Decorating Evergreen.

Look at List of NEW OFFERS Page 548

J. B. Murdoch & Co.

Wholesale Florists

FLORISTS' SUPPLIES

545 Liberty St., PITTSBURG, PA.

Long Distance Phone 1435 Court.

JOHN YOUNG
WHOLESALE FLORIST
 Finest American Beauties and Carnations
 51 West 28 St. - NEW YORK

FORD BROTHERS
 48 West 28th Street, NEW YORK
FINE ROSES FANCY CARNATIONS
 A Full Line of All CUT FLOWERS
 Telephone, 3870 or 3871 Madison Square

H. E. FROMENT,
 Wholesale Commission Florist,
 Choice Cut Flowers,
 57 West 28th St., :: NEW YORK.
 Telephones: 2200, 2201, Madison Square.

The Reliable Commission House
 Richmond Roses and Rich Flowers
 of all varieties
JOS. S. FENRICH
 110 W. 28th Street, New York
 Tel. 324-325 Madison Square

Alfred H. Langjahr
 All choice cut-flowers in season. Send
 for quotations. Correspondence with
 shippers of first-class stock invited.
 55 West 28th Street, New York.
 Telephones 4626-4627 Madison Square

JOHN I. RAYNOR
Wholesale Commission Florist SELLING AGENT FOR LARGEST GROWERS
 A full line of Choice Cut Flower stock for all purposes. Comprises every variety grown for New York market, at current prices
 TEL. 1998 MADISON SQUARE 49 W. 28 St., New York City

Walter F. Sheridan
 Wholesale Commission Dealer in
CHOICE CUT FLOWERS
 39 West 28th Street, New York
 Telephone: 3532-3533 Madison Square

HEADQUARTERS FOR NOVELTIES
ORCHIDS A SPECIALTY
 THE HIGHEST GRADE OF **VALLEY** ALWAYS ON HAND
GARDENIAS, DAISIES, ROSES AND CARNATIONS
JAMES McMANUS, Telephone 759 Mad. Sq. 42 W. 28th St., New York

PHILIP F. KESSLER 55 & 57 W. 26th St., New York City
 Commission Dealer, Wholesale Buyer and Seller of
CUT FLOWERS
 Open from 5 a. m. to 6 p. m. Sunday till 10 a. m.
 Tel., 5243 and 2921 Madison Sq. Res., 345 J., Newtowne.
Finest Lilies in the Market Every Day in the Year.

WHOLESALE COMMISSION FLORIST
J. K. ALLEN 106 W. 28 ST. NEW YORK
 Telephone 167 Madison Sq.
 OPEN 6 A.M. DAILY
 We have a good regular outlet for seasonable flowers

NEW YORK QUOTATIONS PER 100—TO DEALERS ONLY

	Last Half of Week ending April 11 1908	First Half of Week beginning April 13 1908		Last Half of Week ending April 11 1908	First Half of Week beginning April 13 1908
Roses			Cattleyas	40.00 to 60.00	40.00 to 67.00
Am. Beauty, lan and sp.	10.00 to 20.00	12.00 to 25.00	Cypripediums	8.00 to 10.00	8.00 to 10.00
" extra	6.00 to 10.00	8.00 to 12.00	Lilies	5.00 to 8.00	5.00 to 8.00
" No. 1.....	1.00 to 6.00	6.00 to 8.00	Lily of the Valley	1.00 to 2.00	1.00 to 2.00
" Lower grades.....	1.00 to 3.00	.50 to 4.00	Daïsies	1.00 to 1.00	1.00 to 1.00
Bride, 'Maid, fan and sp.....	4.00 to 6.00	4.00 to 6.00	Daffodils	1.00 to 1.50	1.00 to 1.50
" extra.....	1.00 to 3.00	2.00 to 4.00	Tulips	1.00 to 2.00	1.00 to 2.00
" lwr. grds.....	.50 to 1.00	1.00 to 1.50	Mignonette	1.00 to 2.00	1.00 to 2.00
Killarney, Richmond, taacy & spec	4.00 to 8.00	5.00 to 8.00	Gardenias	25.00 to 40.00	35.00 to 50.00
" lower grades.....	.50 to 2.00	1.00 to 3.00	Lilac p r bunch50 to .75	.75 to 1.00
Chatenay, Wellesley, fan. and spec.	4.00 to 6.00	5.00 to 8.00	Sweet Peas per 100 bchs	3.00 to 6.00	3.00 to 10.00
" lower grades.....	.50 to 2.00	1.00 to 2.00	Adiantum50 to .75	.50 to .75
Golden Gate, Ivory.....	.50 to 5.00	1.00 to 6.00	Smilax	10.00 to 15.00	10.00 to 15.00
Carnations, Fancy and Novelties.	1.50 to 2.50	2.00 to 4.00	Asparagus Plumosus, strigs.	20.00 to 30.00	20.00 to 35.00
" Ordinary.....	.75 to 1.00	1.00 to 1.50	" " & Spren. (100 bchs.)	20.00 to 25.00	20.00 to 25.00
Violets15 to .25	.20 to .35			

B. S. SLINN, Jr.
 —WHOLESALE FLORIST—
 55 & 57 W. 26th St., New York City
 Tel., 3864 Madison Sq. Shipping Orders Solicited.
VIOLETS Roses and Carnations

Edward C. Horan
 Wholesale Florist
 55 WEST 28th ST.
 Tel. 1462 Madison Square New York

TRAENDLY & SCHENCK
WHOLESALE FLORISTS
 Furnish best stock at fair prices all the year round Send for quotations on fall orders
 Tel. 798-799 Madison Sq. 44 West 28th Street, New York City

Alexander J. Guttman
THE WHOLESALE FLORIST OF NEW YORK
 43 WEST 28th STREET
 PHONES. 1664--1665 MADISON SQUARE
ENOUGH SAID



HARDY CUT FERN

Sphagnum Moss, Extra Large Bales, per bale, \$1.25. Fancy and Dagger Ferns our specialty. A trial order will convince you that we ship only first-class stock. Headquarters for Florists' supplies and wire work. All cut flowers in season. **BOXWOOD**, per bunch 35c, 50 lbs. \$7.50.
MICHIGAN CUT FLOWER EXCHANGE, INC., All 'phone connections 38-40 Broadway, Detroit, Mich.

FANCY and DAGGER
 Extra fine, \$1.75 per 1000. Bronze and Green Galax, \$1.25 per 1000. Leucothoe Sprays, \$1.00 per 100, \$7.50 per 1000.

Headquarters in Western New York
 FOR
ROSES, CARNATIONS
 And all kinds of Seasonable Flowers
Wm. F. Kasting Co.
 Wholesale Commission Florist, also Dealer in Florists' Supplies and Wire Designs.
383-87 ELLICOTT ST. BUFFALO, N. Y.
 Give us a trial. We can please you.

FRANK S. HICKS & CO.
 Wholesale Florists.
Open Now for Consignments of Cut Flowers.
52 West 28th Street, - New York City
 Tel. 2920 Mad. Sq.

FRANK MILLANG
 Wholesale Florist
 Telegraphic Orders Filled and Delivered.
55-57 West 26th St., New York City.

HENRY M. ROBINSON & CO.
 Wholesale and Commission
FLORISTS
 Hardy Cut Evergreens and Florists' Supplies
15 Province St. and 9 Chapman Place, BOSTON, MASS.

Flowers and Florists' Supplies
 The best place in AMERICA to buy
BAY TREES
N. F. McCarthy & Co.
84 Hawley St., BOSTON, MASS.
 Largest Dealers in Supplies in New England.

WHOLESALE FLOWER MARKETS. — TO DEALERS ONLY.

	CINCINNATI April 13	DETROIT April 13	BUFFALO April 13	PITTSBURG Ap 13
ROSES				
Am. Beauty, Fan. and Sp.	25.00 to 35.00 to	35.00 to 40.00	30.00 to 40.00
" Extra	15.00 to 25.00	30.00 to 40.00	25.00 to 30.00	20.00 to 25.00
" No. 1	10.00 to 15.00	8.00 to 25.00	10.00 to 20.00	10.00 to 15.00
" Lower grades	4.00 to 8.00	6.00 to 10.00	5.00 to 10.00	6.00 to 8.00
Bride, 'Maid, F. & S.	8.00 to 10.00	8.00 to 10.00	10.00 to 12.00	10.00 to 12.00
" Extra	6.00 to 8.00	6.00 to 8.00	8.00 to 10.00	6.00 to 8.00
" " Low gr.	3.00 to 4.00	4.00 to 6.00	4.00 to 6.00 to 4.00
Killarney, Richmond, Fan. & Sp.	8.00 to 10.00	6.00 to 10.00	10.00 to 15.00	10.00 to 12.00
" " Lower grades	4.00 to 6.00	4.00 to 6.00	5.00 to 10.00	6.00 to 8.00
Chateau, Wellesley, Fan. & Sp.	6.00 to 8.00	6.00 to 10.00	10.00 to 15.00	10.00 to 12.00
" " Lower grades	4.00 to 5.00	4.00 to 6.00	4.00 to 8.00	6.00 to 8.00
Golden Gate, Ivory	4.00 to 6.00	4.00 to 6.00 to	4.00 to 6.00
CARNATIONS				
Fancy and Novelties to 3.00	3.00 to 4.00	4.00 to 5.00	3.00 to 4.00
Ordinary	1.00 to 2.00	2.00 to 3.00	2.00 to 4.00	1.50 to 3.00
MISCELLANEOUS				
Violets	.50 to .75	1.00 to75 to 1.00	.50 to .75
Cattleyas	40.00 to 50.00 to 50.00	40.00 to 60.00 to 75.00
Cypripediums to to to to
Lilies	10.00 to 12.50	12.50 to 15.00	12.00 to 15.00	8.00 to 12.50
Lily of the Valley	3.00 to 4.00	3.00 to 4.00	3.00 to 4.00	2.00 to 3.00
Daffodils	1.00 to 2.00 to	1.00 to 2.00	1.50 to 2.00
Tulips	2.00 to 3.00	2.00 to 3.00	3.00 to 4.00	1.50 to 3.00
Mignonette	2.00 to 4.00	2.00 to 3.00	2.00 to 3.00	2.00 to 3.00
Gardenias to 25.00	4.00 to 8.00	3.00 to 5.00	3.00 to 4.00
Lilac per bunch to 1.00	35.00 to 50.00	15.00 to 25.00 to
Sweet Peas	.50 to .75	1.50 to50 to 1.00	.50 to 1.00
Adiantum to 1.00	1.50 to50 to 1.50 to 1.25
Whitmanii Fronds to75 to 1.50 to to
Smilax	10.00 to 12.50 to to 15.00	12.50 to 15.00
Asparagus Plumosus, strigs.	40.00 to 50.00	10.00 to 15.00 to 50.00	20.00 to 50.00
" " & Spren. (too behs.)	25.00 to 35.00	25.00 to 60.00 to 50.00	30.00 to 50.00
		30.00 to 50.00	25.00 to 50.00	30.00 to 40.00

SAMUEL A. WOODROW
 WHOLESALE PLANTSMAN
 Palms, Large and Small Ferns, etc.
53 West 30th Street, NEW YORK
 Telephone 2083 Madison

WILLIAM H. KUEBLER
 Brooklyn's Foremost and Best
WHOLESALE COMMISSION HOUSE
 A First Class Market for all CUT FLOWERS
28 Willoughby St., Brooklyn, N. Y.
 Tel. 4591 Main

CLEARY'S HORTICULTURAL CO.
 Management AMBROSE T. CLEARY
 Wholesale Contracting, Jobbing, Auction
HORTICULTURAL PRODUCTS
 of every description.
 Consignments Received. Surplus Stock Converted.
62 Vesey St., NEW YORK

Moore, Hentz & Nash,
 Wholesale Commission Florists,
 55 and 57 West 26th Street,
 Telephone No. 756
Madison Square. New York.

H. G. BERNING
 Wholesale Florist
 1402 Pine Street, ST. LOUIS, MO.

MILLANG BROS.
 WHOLESALE COMMISSION FLORISTS
 41 West 28th Street
 Telephone 3860
Madison NEW YORK

A. MOLTZ
 Will purchase flowers on order in N. Y. market and ship carefully at prevailing wholesale prices. Address
55-57 West 26th Street, New York City

REED & KELLER
 122 West 25th St., New York
Florists' Supplies
 We manufacture all our
Metal Designs, Baskets, Wire Work & Novelties
 and are dealers in
 Glassware Decorative Greens and Florists' Requisites.

In writing to Advertisers kindly mention Horticulture

Buyer's Directory and Ready Reference Guide

Advertisements under this head, one cent a word. Initials count as words.

Regular advertisers in this issue are also listed under this classification without charge. Reference to List of Advertisers will indicate the respective pages.

Buyers failing to find what they want in this list will confer a favor by writing us and we will try to put them in communication with reliable dealers.

ACCOUNTANT

R. J. Dysart, 28 State St., Boston.
For page see List of Advertisers.

ALTERNANTHERAS

Red Alternantheras at 40 cents per 100.
C. W. Moeckel, 17 Summer St., Fitchburg, Mass.

AQUATIC PLANTS

Aquarium plants the year round. Wholesale and retail. Send for price list. Schmid's Emporium of Pets, 712 12th Street, Washington, D. C.

ARAUCARIAS

Godfrey Aschmann, 1012 Ontario St., Philadelphia, Pa.

Araucaria excelsa, 6 in., splendid stock, \$9.00 per doz. Holton & Hunkel Co., Milwaukee, Wis.

ASPARAGUS

A. N. Pierson, Cromwell, Conn.
Asparagus Plumosus Seedlings.
For page see List of Advertisers.

Asparagus plumosus and Sprenger, 2-in., strong, \$2.00 per 100. J. H. Dann & Son, Westfield, N. Y.

150 Asparagus plumosus nanus, 2½-in., extra fine, 3c; 300 Pteris Onwardi, 2½-in., 2c; heliotropes, 2 in., 2c; dahlia roots, best varieties, \$2.00 per 100; mixed, \$1.50. Edwin Bishop, Roslyn, Md.

Asparagus Plumosa, 2 in. pots. Fine plants, \$3.00 per 100; \$25.00 per 1000. Cash with order or good reference. Erle Floral Co., Erie, Pa.; or, Wm. F. Kastling Co., 385 Elliott St., Buffalo, N. Y.

ASPARAGUS ROOTS

D. Landreth Seed Co., Bristol, Pa.
For page see List of Advertisers.

AUCTION SALES

Cleary's Horticultural Co., 62 Vesey St., New York.

Horticultural Products of Every Description.
For page see List of Advertisers.

Wm. Elliott & Sons, 201 Fulton St., New York.

For page see List of Advertisers.

Fruit Auction Co., Franklin and Washing Daily Plant Auctions.
Sts., New York.

AZALEAS

A. Leuthy & Co., Perkins St. Nurseries, Rosindale, Mass.
For page see List of Advertisers.

August Rolker & Sons, New York, 31 Barclay St., or P. O. Box 752.
For page see List of Advertisers.

W. W. Edgar Co., Waverley, Mass.

Godfrey Aschmann, 1012 W. Ontario St., Philadelphia.

Azalea amoena, young plants, \$5, \$10 and \$15 per 100. Fine plants full of buds, \$50 per 100; 2 1/2 to 3 ft., \$100 per 100. Ask for list of trees and shrubs in variety. Samuel C. Moon, Morrisville, Pa.

BAMBOO CANES

Stump & Walter Co., 50 Barclay St., New York.
For page see List of Advertisers.

Yokohama Nursery Co., 31 Barclay Street, New York.
For page see List of Advertisers.

BAY TREES.

N. F. McCarthy & Co., 84 Hawley St., Boston.

For page see List of Advertisers.

Bay Trees and Box Trees, standards and pyramids. All sizes. Price list on application. J. Roehrs Co., Rutherford, N. J.

BEDDING PLANTS

R. Vincent, Jr., & Sons Co., White Marsh, Maryland.

For page see List of Advertisers.

BEGONIAS

Thomas Roland, Nahant, Mass.
Gloire De Lorraine.

For page see List of Advertisers.

Begonia Pres. Carnot, 2 1/2 in., \$3.00 100. Valley Greenhouse Co., Sewickley, Pa.

BOILERS

BOILERS. "Burnham" Boilers made for greenhouse heating. Lord & Burnham, 1133 Broadway, N. Y.

BUILDERS' AND FARM LEVELS

Bostrom-Brady Mfg. Co., 130 Madison Ave., Atlanta, Ga.

For page see List of Advertisers.

BUILDING MATERIAL

BUILDING MATERIAL of all description for All Cypress, Semi-iron, iron Frame or Truss Houses. Hot Bel Sash and Frames. Lord & Burnham Co., 1133 Broadway, N. Y.

BULBS AND TUBERS

Joseph Breck & Sons, 47-54 N. Market St., Boston.

For page see List of Advertisers.

J. M. Thornburn & Co., 33 Barclay St., New York.

For page see List of Advertisers.

A. T. Boddington, 342 W. 14th St., N. Y.
For page see List of Advertisers.

Rickards Bros., 37 East 19th St., New York.
For page see List of Advertisers.

H. F. Michell Co., Philadelphia.

For page see List of Advertisers.

H. E. Fiske Seed Co., Faneuil Hall Sq., Boston.

For page see List of Advertisers.

James Vick's Sons, Rochester, N. Y.

Fall Bulbs.

For page see List of Advertisers.

Aug. Rolker & Sons, 31 Barclay St., New York.

Seasonable Import Plants and Bulbs.

For page see List of Advertisers.

K. Velthuis, Hillegom, Holland.
Represented by Felix Bosch, 260 Clarendon St., Boston.

Bulbs French and Dutch.

For page see List of Advertisers.

Ralph M. Ward & Co., 2 W. Broadway, New York, Agents for Martial Bremond, Orloules, France.

French Bulbs.

For page see List of Advertisers.

Stump & Walter Co., 50 Barclay St., N. Y.
Canna Bulbs.

For page see List of Advertisers.

D. Rusconi, 128 W. Sixth St., Cincinnati, O.
Cold Storage.

V. H. Hallock & Son, Queens, N. Y.
Lilium Auratum and Double Begonia Bulbs.

CANNAS

The Conard & Jones Co., West Grove, Pa.
For page see List of Advertisers.

J. B. Shurtleff & Son, Cushman Ave., Revere, Mass.

Live Cannas started from Sand.

For page see List of Advertisers.

CARNATIONS

F. Dorer & Sons Co., Lafayette, Ind.
For page see List of Advertisers.

S. S. Skidelsky, 1741 N. 18th St., Philadelphia.

For page see List of Advertisers.

Chicago Carnation Co., Joliet, Ill.

For page see List of Advertisers.

John E. Haines, Bethlehem, Pa.

Carnations Imperial and Pluk Imperial.

For page see List of Advertisers.

Chas. H. Totty, Madison, N. J.

For page see List of Advertisers.

A. N. Pierson, Cromwell, Conn.

For page see List of Advertisers.

Strong, Fair Maid, \$1.00 per 100. Write for others. Sallerol for sale. Otto Bourdy, Lowell, Mass.

White Enchantress, unrooted cuttings. Write for prices. Won first prize for best vase of 50. F. H. Westhoff, De Haven, Pa.

Carnation cuttings of all the leading varieties at the same price as any reliable firm. Write for prices before you look elsewhere. Wm. F. Kastling Co., 383 Elliott St., Buffalo, N. Y.

CARNATIONS! FIELD GROWN!!

15,000 Enchantress and Winsor, ready for delivery July 1st. Orders filled in strict rotation. Order now and be first! Prices on application. We guarantee satisfaction. We lead in superb field grown stock.

WANOKA GREENHOUSES,

Barneveld, N. Y.

CHRYSANTHEMUMS

Chas. H. Totty, Madison, N. J.

Single Chrysanthemums.

For page see List of Advertisers.

A. N. Pierson, Cromwell, Conn.

For page see List of Advertisers.

Chrysanthemum rooted cuttings, best varieties; write for list and prices. Edwin Bishop, Roslyn, Md.

Chrysanthemums. 5000 unrooted cuttings of Yellow Bonaffon, 70c. per 100. F. H. Westhoff, De Haven, Pa.

Have 100,000 fine young well-rooted 'Mums, cuttings of the best 60 commercial varieties. Send for our new and low price list. Satisfaction guaranteed. Wm. Ehmman, Jr., Corfu, N. Y.

Chrysanthemums ready: 2 1/2 inch strong stock of Touse, Oct. Frost, Polly Rose, Wanamaker, and all standards, \$3 per 100, \$25 per M. New: 2 1/2, strong, Alice Roosevelt, Hankey, Clay Frick, Winter Cheer, Rosette, B. May, \$5 per 100, \$40 per M. Cash. Send for catalog. Hartwarden Greenhouses, Greenport, N. Y.

COLEUS

Coleus Golden Bedder, Verschaffeltii, 2 in. \$2.00 100; rooted cuttings, 60c. 100. Valley Greenhouse Co., Sewickley, Pa.

Coleus, Golden Bedder, Verschaffeltii, and mixed Coleus, rooted cuttings, 60c. per 100; \$5.00 per 1000. Cash with order. J. E. Felthousen, Florist, Schenectady, N. Y.

CONIFERS

John Waterer & Sons, Ltd., American Nursery, Bagshot, Eng.

For page see List of Advertisers.

New England Nurseries, Bedford, Mass.

For page see List of Advertisers.

CUT FLOWER BOXES.

Edwards Folding Box Co., Philadelphia.

For page see List of Advertisers.

Folding cut flower boxes, the best made. Write for list. Holton & Hunkel Co., Milwaukee, Wis.

For List of Advertisers See Page 549

CYCLAMEN.

Cyclamen seedlings, fine stock, \$1.50 per 100. Holton & Hunkel Co., Milwaukee, Wis.

DAHLIAS

David Herbert & Son, Atco, N. J.
For page see List of Advertisers.

J. L. Moore, Northboro, Mass.
For page see List of Advertisers.

Henry A. Dier, 714 Chestnut St., Philadelphia.

15,000 Field-grown clumps 2c. and up. List ready. H. W. Koerner, Sta. B, Milwaukee, Wis.

Dahlia Bulbs, 25 choice named varieties, 1-3 Cactus, for \$1. Catalog free. C. Peirce, Dighton, Mass.

Dahlias, double; strong field-grown roots, mixed, \$2.00 per 100; named, \$3.50 per 100. H. H. Kern, Bonner Springs, Kan.

Dahlias: About 2000 Cath. Duer, Kreimhilde, Bruhilde, Snowlad, etc., \$3 per 100. Cash. Harlowarden Greenhouses, Greepport, N. Y.

Dahlias. Novelties and standard varieties, true to name, a choice list of the best introductions. Send for catalogue of dahlias, hollyhocks, hardy plants, etc. W. W. Wilmore, Box 382, Denver, Colo.

Dahlia Roots—Undivided field clumps, Lyndhurst, Maid of Kent, William Agnew, White Swan, Kreimhilde, John Walker, Arabella and A. D. Livoni. Write for low prices. Wood & Healey, Hammonton, New Jersey.

The East Bridgewater Dahlia Gardens have 50 varieties of up-to-date dahlias to offer in full field clumps just as dug. Over 200,000 clumps. Send to the eastern dahlia king for rock bottom price list. J. K. Alexander, East Bridgewater, Mass.

Cactus, Decorative, Show, Fancy and Pompon Dahlias. 75 leading varieties to select from. Strong divided clumps, in 10 or 20 varieties, my selection at \$3.00 per 100; \$25.00 per 1000. Single Dahlias, mixed, \$1.00 per 100. Cash with order please. Hermann Thiemann, Monson, Mass.

DECORATIVE PLANTS

A. Leuthy & Co., Perkins St. Nurseries, Roslindale, Mass.
For page see List of Advertisers.

ELECTRIC CIRCULATOR

The Castle Co., 170 Summer St., Boston.

EUONYMUS RADICANS

Euonymus radicans, 1-1 1/2 ft., \$6.00; 2-2 1/2 ft., \$8.00 per 100. Bushy plants. Brae-Burn Nursery, West Newton, Mass.

EVERGREENS

The New England Nurseries, Bedford, Mass.

For page see List of Advertisers.

Evergreens—Colorado spruce, 6 to 8 ft.; Norway spruce, 10 to 14 ft.; Eastern spruce 6 to 8 ft.; Nordmann's fir, 4 to 6 ft., also 1 to 2 ft. Small evergreens for nursery planting, in great variety. Ask for list. Samuel C. Moon, Morrisville, Pa.

FERNS

A. Leuthy & Co., Roslindale, Mass.
For page see List of Advertisers.

H. H. Barrow & Son, Whitman, Mass.
Nephrolepis Whitmanii.
For page see List of Advertisers.

John Scott, Brooklyn, N. Y.
For page see List of Advertisers.

Baur Floral Co., Erie, Pa.
For page see List of Advertisers.

Godfrey Aschmann, 1012 Ontario St., Philadelphia, Pa.

Nephrolepis Exaltata Bostonensis, fine young plants, \$10.00 per 1000.

N. Elegantisima, young plants \$15.00 per 1000. Send for price list. Soar Bros. Little River, Fla.

FERTILIZERS

Pulverized Manure Co., 31 Union Stock Yards, Chicago, Ill.

Wizard Brand Cattle Manure.
For page see List of Advertisers.

Thos J Gray & Co.,
32 and 33 South Market St., Boston.
High-Grade Scotch Soot.
For page see List of Advertisers.

FICUS

Ficus elastica, 5-in., extra fine stock, \$4.00 per doz. Holton & Hunkel Co., Milwaukee, Wis.

FLORAL PHOTOGRAPHS

Floral Photographs. Foley's 226-228 1-2 Bowery, New York.

FLORISTS' LETTERS.

Boston Florist Letter Co., 66 Pearl St., Boston, Mass.

For page see List of Advertisers.

Koral Mfg. Co., 26 Hawley St., Boston.
For page see List of Advertisers.

FLORISTS SUPPLIES

N. F. McCarthy & Co., 84 Hawley St., Boston.

For page see List of Advertisers.

H. M. Robinson & Co., 15 Province St. and 9 Chapin Pl., Boston, Mass.
For page see List of Advertisers.

The Keivan Co., 113 W. 28th St., N. Y.
Decorative Evergreens.
For page see List of Advertisers.

Meed & Keller, 122 W. 25th St., New York.
For page see List of Advertisers.

J. B. Mudoch & Co., 714 Penn Ave., Pittsburg, Pa.

For page see List of Advertisers.

H. Bayersdorfer & Co., 1129 Arch St., Philadelphia.

For page see List of Advertisers.

Alex. Maun, Jr., Co., 1125 Polk St., San Francisco, Calif.

For page see List of Advertisers.

FLOWERS BY TELEGRAPH

Park Floral Co., Denver, Colo.

For page see List of Advertisers.

J. N. Champion & Co., 1026 Chapel St., New Haven, Conn.

For page see List of Advertisers.

George H. Cooke, Washington, D. C.

For page see List of Advertisers.

Gude Bros. Co., 1214 F St., Washington, D. C.

For page see List of Advertisers.

Atlanta Floral Co., Atlanta, Ga.

For page see List of Advertisers.

M. C. & J. E. Hauswirth, 232 Michigan Ave., Chicago.

For page see List of Advertisers.

William J. Smyth, Michigan Ave. and 31st St., Chicago.

For page see List of Advertisers.

George Wittbold Co., 1657-59 Buckingham Place, Chicago.

For page see List of Advertisers.

Jacob Schulz, 644 4th Ave., Louisville, Ky.

For page see List of Advertisers.

Thos F. Galvin, 124 Tremont St., Boston.

For page see List of Advertisers.

Julius A. Zinn, 2 Beacon St., Boston.

For page see List of Advertisers.

Houghton & Clark, 396 Boylston St., Boston.

For page see List of Advertisers.

Sidney Hoffman, 59-61 Massachusetts Ave., Boston.

For page see List of Advertisers.

Edward MacMulkin, 194 Boylston St., Boston.

For page see List of Advertisers.

J. Breitmeyer's Sons, Miami and Gratiot Aves., Detroit, Mich.

For page see List of Advertisers.

Samuel Murray, 1017 Broadway, Kansas City, Mo.

For page see List of Advertisers.

Wm. L. Rock Flower Co., 1116 Walnut St., Kansas City, Mo.

For page see List of Advertisers.

Fred C. Weber, 426-28 Olive St., St. Louis, Mo.

For page see List of Advertisers.

H. G. Eyres, 11 N. Pearl St., Albany, N.Y.

For page see List of Advertisers.

David Clarke's Sons, 2159-2141 Broadway, New York.

For page see List of Advertisers.

W. H. Donohoe, 17 E. 28th St., New York.

For page see List of Advertisers.

Alex. McConnell, New York.

For page see List of Advertisers.

FLOWERS BY TELEGRAPH—Continued

M. A. Bowe, 1294 Broadway, New York.
For page see List of Advertisers.

Robert G. Wilson, Fulton St. & Greene Av., Brooklyn, N. Y.

For page see List of Advertisers.

Thomas Young, Jr., 500 Fifth Ave., N. Y.
For page see List of Advertisers.

Young & Nugent, 42 W. 28th St., N. Y.
For page see List of Advertisers.

J. H. Dunlop, 96 Yonge St., Toronto, Can.
For page see List of Advertisers.

FLOWER POTS

W. H. Ernest, 28th and M Sts., Washington, D. C.

For page see List of Advertisers.

A. H. Hewa & Co., Cambridge, Mass.
For page see List of Advertisers.

Hilfinger Bros., Ft. Edward, N. Y.
For page see List of Advertisers.

Red pots, seed pans, etc.

The Peters & Reed Pottery Co., Zanesville, O.

FORESTRY AND ORNAMENTAL PLANTING

Jackson's Nurseries, Portland, Me.
For page see List of Advertisers.

FUCHSIAS

Fuchsias, finest mixed, 2 in., \$2.50 per 100; rooted cuttings, \$1.00. Valley Greenhouse Co., Sewickley, Pa.

GALAX

Michigan Cut Flower Co., 38 and 40 Broadway, Detroit, Mich.

For page see List of Advertisers.

Crowl Fern Co., Millington, Mass.

GERANIUMS

R. Vincent Jr. & Sons Co., White Marsh, Md.

New and Standard Varieties.

For page see List of Advertisers.

Geraniums, 2-in., double red, \$2.00 per 100. J. H. Dann & Son, Westfield, N. Y.

500 Nutt Geranium Cuttings, \$1.50 per 100, or the lot for \$6.50. C. W. Moeckel, 17 Summer St., Fitchburg, Mass.

Geraniums Nutt, Doyle, Castellane, Perkins, La Favorite, Mme. Sallerol, 2-in., \$2.50 per 100; my selection, \$2.00 per 100. Fleur Blanc, the new white, 75c. doz.; \$4.00 per 100; A. H. Trego, 50c. doz.; \$3.50 per 100. William Doel, Pascoag, R. I.

GLADIOLI

Arthur Cowee, Meadowvale Farm, Berlin, New York.

For page see List of Advertisers.

J. L. Moore, Northboro, Mass.

For page see List of Advertisers.

I. & J. L. Leonard, Iona, N. J.

Gladiolus Bulbs.

For page see List of Advertisers.

Gladiol. Write for leaflet. B. Hammond Tracy, Cedar Acres, Webham, Mass.

Gladiolus Bulbs and hand hybridized seed. Newest. Best. Circular free. B. F. White, Terryville, Conn.

GLASS

Boston Plate & Window Glass Co., Boston.
For page see List of Advertisers.

Standard Plate Glass Co., 26-30 Sudbury St., Boston.

For page see List of Advertisers.

S. Jacobs & Sons, 1365-79 Flushing Ave., Brooklyn, N. Y.

For page see List of Advertisers.

Parshelsky Bros., 59 Montrose Ave., Brooklyn, N. Y.

Metropolitan Material Co., 1398-1408 Metropolitan Ave., Brooklyn, N. Y.

Foley Mfg. Co., Western Ave., between 25th & 26th Sts., Chicago.

Greenhouse glass, lowest prices. Johnston Glass Co., Hartford City, Ind.

GLASS, High Grade, Double Thick Greenhouse Glass. Lord & Burnham, 1133 Broadway, N. Y.

In writing to Advertisers kindly mention Horticulture

GLAZING POINT

H. A. Dreer, Philadelphia, Pa.
For page see List of Advertisers.

GLAZING POINTS, Lord & Burnham
Special Glazing Nails (Points). Lord &
Burnham, 1133 Broadway, N. Y.

GREENHOUSE BUILDING MATERIAL

Lord & Burnham Co.,
1133 Broadway, New York.

For page see List of Advertisers.

Pierson U-Bar Co., 1 Madison Sq., N. Y.
For page see List of Advertisers.

A. T. Stearns Lumber Co., Neponset,
Boston.

For page see List of Advertisers.

King Construction Co., N. Tonawanda,
New York.

For page see List of Advertisers.

J. C. Moninger Co., 117 East Blackhawk St.,
Chicago, Ill.

For page see List of Advertisers.

Foley Mfg. Co., Western Ave., between
25th & 26th Sts., Chicago.

For page see List of Advertisers.

I. Cassidy, Summer Ave. and Erie R. R.,
Newark, N. J.

For page see List of Advertisers.

W. H. Lutton, Jersey City, N. J.
For page see List of Advertisers.

Geo. B. Doane, 18 Midway St., Boston.
Iron Pipe.

For page see List of Advertisers.

S. Jacobs & Sons, 1365-79 Flushing Ave.,
Brooklyn, N. Y.

For page see List of Advertisers.

Metropolitan Material Co., 1398-1408 Metro
politan Ave., Brooklyn, N. Y.

GREENHOUSE CONSTRUCTION
GREENHOUSE CONSTRUCTION, Semi
Iron Greenhouse, New Truss House and
Iron Frame Houses. Lord & Burnham,
1133 Broadway, N. Y.

J. A. Payne, 260-274 Culver Ave., Jersey
City, N. J.

For page see List of Advertisers.

I. Cassidy, Summer Ave. and Erie R. R.,
Newark, N. J.

For page see List of Advertisers.

Foley Mfg. Co., Western Ave., between
25th & 26th Sts., Chicago.

For page see List of Advertisers.

W. H. Lutton, Jersey City, N. J.
For page see List of Advertisers.

GUTTERS

GUTTERS, Cast Iron Gutters, L. & B.
Improved V Shaped Gutter with drip gut
ter attachment. Lord & Burnham, 1133
Broadway, N. Y.

HAIL INSURANCE

Florists' Hall Asso. of America.
J. G. Esler, Saddle River, N. J.
For page see List of Advertisers.

HARDY FERNS AND SUPPLIES

H. M. Robinson & Co., 15 Province St
and 9 Chapman Pl., Boston, Mass.
For page see List of Advertisers

The Kevan Co., 112 W. 28th St., N. Y.
For page see List of Advertisers.

Michigan Cut Flower Exchange,
38 and 40 Broadway, Detroit, Mich.
Fancy Ferns.

For page see List of Advertisers.

H. J. Smith, Hinsdale, Mass.

For page see List of Advertisers.

Crowl Fern Co., Milington, Mass.

HARDY PLANTS

Hardy Plants. We have one of the finest
assortments of seedlings, transplanted and
field-grown stock. Get our prices and de-
scriptions. Mosback Greenhouse Co., Onar-
ga, Ill.

Lobelia cardinalis, large clumps, \$1.50
per doz., \$8.00 per 100. Gentiana Andrewsil
and linearis. In clumps, \$1.50 per doz., \$8.00
per 100. Native ferns, trees and shrubs at
prices to suit. A fine lot of nursery grown
White Pine, Hemlock, Fir Balsam, Norway
and White Spruce of various sizes at re-
duced prices. L. E. Williams, Nottingham,
N. H.

HART'S HANDY HANDLE

Geo. B. Hart, 21 Stone St., Rochester, N. Y.
For page see List of Advertisers.

HEATING APPARATUS

Lord & Burnham Co.,
1133 Broadway, New York.

For page see List of Advertisers.

Pierson U-Bar Co., 1 Madison Sq., N. Y.
For page see List of Advertisers.

John A. Payne, 260-274 Culver Ave., Jersey
City, N. J.

For page see List of Advertisers.

HELIOTROPES.

Heliotropes, 2 in., 2c.; rooted cuttings,
from soil, 75c. per 100. Edwin Bishop,
Roslyn, Md.

Heliotropes, 2 in., \$2.50 100; rooted cut-
tings, \$1.00 100. Valley Greenhouse Co.,
Sewickley, Pa.

HELP FURNISHED

Thos. H. Bambrick, 34 S. 7th St., Phila.
For page see List of Advertisers.

HERBACEOUS PERENNIALS

Red Oak Nurseries, Fiskeville, R. I.
For page see List of Advertisers.

HOLLYHOCKS

Hollyhocks, separate colors, field grown,
healthy stock, \$3.00 per 100; also Dahlias,
novelties and standard varieties. Send for
catalogue. W. W. Wilmore, Box 382, Den-
ver, Colo.

HOSE

Frank L. Moore, Chatham, N. J.
Sunnyside Hose.

For page see List of Advertisers.

J. G. & A. Esler, Saddle River, N. J.
Mineralized Rubber Co., 18 Cliff St., N. Y.

HOT-BED SASH

The A. T. Stearns Lumber Co., Neponset,
Mass.

For page see List of Advertisers.

Pierson U-Bar Co., 1 Madison Sq., N. Y.
For page see List of Advertisers.

Lord & Burnham Co., 1133 Broadway, N. Y.
For page see List of Advertisers.

Foley Mfg. Co., Western Ave., between
25th & 26th Sts., Chicago.

HYDEANGEAS.

HYDRANGEAS PANICULATA.

Grandiflora, 18-in. to 24-in., \$5.00 per 100.
Grandiflora, 2 ft. to 3 ft., \$7.00 per 100.
Grandiflora, 3 ft., \$8.00 per 100.
J. H. Dann & Son, Westfield, N. Y.

IMPROVED ECONOMY BRACKET

Buxton & Allard, Nashua, N. H.

INSECTICIDES.

Nicotinide kills all greenhouse pests
P. R. Palethorpe Co.,
Eleventh St., Owensboro, Ky.
For page see List of Advertisers.

IRISES

J. M. Thorburn & Co., 33 Barclay St.,
New York.

For page see List of Advertisers.

Japan Iris (Iris Kaempferi), divided
roots, 2-5 shoots, mixed, \$4.00 per 100;
divided roots, 2-5 shoots, white, \$5.00 per
100. Large clumps, 10c. each. Wm. F.
Halsey, Southampton, N. Y.

Iris pallida dalmatica, a beautiful shade
of lavender; the largest and most beauti-
ful of all the German Irises; perfectly
hardy, and free flowering. One of the good
things almost lost to horticulture. \$12.00
per 100; \$100.00 per 1,000. Cash with or-
der. J. A. Peterson, McHenry Ave., West-
wood, Cincinnati, O.

JAPANA CUT FLOWER HOLDER

M. V. Garnsey, 130 Walola Ave.,
La Grange, Ill. Dept. A.

KENTIAS

A. Leuthy & Co., Roslindale, Mass.
For page see List of Advertisers.
Godfrey Aschmann, 1012 W. Ontario St.,
Philadelphia.

LAWN VASES

Kramer Bros. Ely. Co., Dayton, Ohio.
For page see List of Advertisers.

LEADING RETAIL FLORISTS

Park Floral Co., Denver, Colo.
For page see List of Advertisers.

George H. Cooke, Washington, D. C.
For page see List of Advertisers.

Gude Bros. Co., 1214 F St.,
Washington, D. C.

For page see List of Advertisers.

Atlanta Floral Co., Atlanta, Ga.
For page see List of Advertisers.

M. C. & J. E. Hauswirth, 232 Michigan Ave.,
Chicago.

For page see List of Advertisers.

William J. Smyth, Michigan Ave. and 31st
St., Chicago.

For page see List of Advertisers.

George Wittbold Co., 1657-59 Buckingham
Place, Chicago.

For page see List of Advertisers.

Jacob Schulz, 644 4th Ave., Louisville, Ky.
For page see List of Advertisers

Thos. F. Galvin, 124 Tremont St., Boston.
For page see List of Advertisers.

Julius A. Zinn, 2 Beacon St., Boston.

For page see List of Advertisers.

Houghton & Clark, 396 Boylston St.,
Boston.

For page see List of Advertisers.

Sidney Hoffman, 59-61 Massachusetts Ave.,
Boston.

For page see List of Advertisers.

Edward MacMinkin, 194 Boylston St.,
Boston.

For page see List of Advertisers.

J. Bretmeyer's Sons, Detroit, Mich.
For page see List of Advertisers.

Samuel Murray, 1017 Broadway,
Kansas City, Mo.

For page see List of Advertisers.

Wm. L. Rock Flower Co., 1118 Walnut
St., Kansas City, Mo.

For page see List of Advertisers.

Fred C. Weber, 4328 Olive St., St. Louis,
Mo.

For page see List of Advertisers.

J. N. Champlin & Co., 1026 Chapel St.,
New Haven, Conn.

For page see List of Advertisers.

H. G. Eyres, 11 N. Pearl St., Albany, N. Y.
For page see List of Advertisers.

David Clarke's Sons, 2139-2141 Broadway,
New York.

For page see List of Advertisers.

W. H. Donohoe, 17 E. 28th St., New York.
For page see List of Advertisers.

Alex. McConnell, New York.

For page see List of Advertisers.

M. A. Bowe, 1291 Broadway, New York.
For page see List of Advertisers.

Robert G. Wilson, Fulton St. and Greene
Ave., Brooklyn, N. Y.

For page see List of Advertisers.

Thomas Young, Jr., 500 Fifth Ave., N. Y.
For page see List of Advertisers.

Young & Nugent, 42 W. 28th St., N. Y.
For page see List of Advertisers

J. H. Dunlop, 96 Yonge St., Toronto, Can.
For page see List of Advertisers.

LILIES

Miami Floral Co., Dayton, O.
For page see List of Advertisers.

NEW AND RARE PLANTS

Rose Hill Nurseries, New Rochelle, N. Y.
For page see List of Advertisers.

MASTICA

F. O. Pierce Co., 12 W. Broadway,
New York.

For page see List of Advertisers.

MISSION PLANT BOX

Wagner Park Conservatories, Sidney, O.

MOON VINES

Moon vines, fine strong plants, 3 in.,
\$1.00 per 100. Edwin Bishop, Roslyn, Md.

NICO-FUME

Kentucky Tobacco Product Co.,
Louisville, Ky.

For page see List of Advertisers.

For List of Advertisers See Page 549

NURSERY STOCK

John Waterer & Sons, Ltd.,
American Nursery, Bagshot, England.
For page see List of Advertisers.

New England Nurseries, Bedford, Mass.
Shrubs, Roses and Herbaceous Perennials.
Specimen Pyramidal Box.
For page see List of Advertisers.

Bay State Nurseries, N. Abington, Mass.
Herbaceous Perennials, Hardy Ornamental
Trees.
For page see List of Advertisers.

Cleary's Horticultural Co., 62 Vesey St.,
New York.
For page see List of Advertisers.

P. Ouwkerk, 216 Jane St., Weehawken
Heights, N. J.
Holland Nursery Stock for Forclog.
For page see List of Advertisers

American Nursery Co., 150 Broadway, New
York, N. Y.
For page see List of Advertisers.

I. & J. L. Leonard, Iona, N. J.
California Privet, American Chestnuts.
For page see List of Advertisers.

The Morris Nursery Co.,
Sales Office, 1 Madison Ave., New York.
Ornamental Trees, Evergreens, Hedge
Plants.
For page see List of Advertisers.

Peter's Nursery Co., Knoxville, Teon.
Live Fences; Amoor and California Privet.
For page see List of Advertisers.

L. L. May & Co., St. Paul, Minn.
Shrubs, Roses, Small Fruits, Ornamental
and Fruit Trees.

Nursery Stock—Berberis Thunbergii 1
yr. seedlings, \$10 per 1000; 2 yrs., \$15 per
1000. Viburnum plicatum, \$50, \$60 and
\$80, per 1000. Ligustrum Iboti, 4 ft., \$9
per 100. Rosa Wichuraiana, 4 to 6 ft.
Lonicera Morrow, 3 to 4 ft. Bignonia
Thunbergii and radicans. Send for list of
shrubs, large and small. Samuel C. Moon,
Morrisville, Pa.

NURSERY STOCK.

Per 100
2,500 Berberis Thunbergii, 2 to 3 ft. \$9.00
1,000 Cornus Spathi, golden, 1 1/2 to 2 ft. 10.00
1,000 Cydonia Japonica, 2 1/2 to 3 ft. 9.00
500 Dentzia Pride of Rochester. 10.00
500 Forsythia in 3 varieties. 10.00
500 Hydrangea Pan. grand. 10.00
10,000 Ligustrum Iboti, 2 1/2 to 3 ft. 8.00
1,000 Crimson Ramblers, 2 yrs. 9.00 & 10.00
1,000 Dorothy Perkins, 2 yrs. 9.00 & 10.00
Rhododendrons, Azaleas, etc. etc.
The Continental Nurseries, Franklin, Mass.

ORCHID PLANTS

Lager & Hurrell, Summit, N. J.
For page see List of Advertisers.

Sander, St. Albans, England.
Importers, Exporters, Growers, Hybridists
For page see List of Advertisers.

Julius Roehrs Co., Rutherford, N. J.
For page see List of Advertisers.

Carrillo & Baldwin, Secaucus, N. J.
For page see List of Advertisers.

Jos. A. Manda, 191 Valley Road, W.
Orange, N. J.
For page see List of Advertisers.

Ordonez Bros., Madison, N. J., Box 105
For page see List of Advertisers.

PALMS

A. Leuthy & Co., Perkins St. Nurseries
Rosindale, Mass.
For page see List of Advertisers.

Robert Craig Co., Market and 49th Sts.,
Philadelphia, Pa.
For page see List of Advertisers.

Kentia, Phoenix, etc., all sizes. Write
for new price list. Julius Roehrs Co.,
Rutherford, N. J.

PAINT AND PUTTY

PAINT AND PUTTY: Ideal Greenhouse
lead; Special Greenhouse Putty. Lord &
Burnham, 1133 Broadway, N. Y.

PANSY PLANTS.

Pansy Plants. From extra selected
seed. Fall seedlings \$3.50 per 1000. Fall
transplanted \$6.00 per 1000. Large plants
\$10.00 per 1000. Mosbaek Greenhouse Co.,
Onarga, Ill.

PATENTS

Siggere & Siggers, Washington, D. C.
For page see List of Advertisers.

PEAT

Orchid peat, Rotted peat, Azalea peat,
Leaf-Mould, Live Sphagnum moss, Baled
Sphagnum moss, Green Clump moss, etc.
Jobbers' list on application. C. W. Brown-
ell & Co., Walden, N. Y.

PELARGONIUMS

R. Vincent, Jr. & Sons Co., White Marsh,
Maryland.
For page see List of Advertisers.

PEONIES

Wholesale Peony list for fall 1908 is now
ready. J. F. Rosebush, West Point, Neb.
One of the finest collections in America.
Send 25 cts. in stamps for new edition of
Peony Manual. C. S. Harrison's Select
Nursery, York, Neb.

PHLOXES

Send 25 cts. in stamps for Phlox Manual.
Fine mixed phloxes \$1.50 per 100. C. S.
Harrison's Select Nursery, York, Neb.

PIPE AND FITTINGS

Foley Mfg. Co., between Western Ave. and
26th St., Chicago, Ill.

Eagle Metal & Supply Co., Johnson and
Union Aves., Brooklyn, N. Y.
Second-Hand Pipe and Boiler Tubes.
For page see List of Advertisers.

PIPE AND FITTINGS. Cast Iron and
Wrought Pipe, Valves, Elbows, Pipe Hooks,
Automatic Air Headers, etc. Lord &
Burnham, 1133 Broadway, N. Y.

PLANT BED CLOTH

Mineralized Rubber Co., 18 Cliff St., N. Y.

PLANT STAKES AND TRELLISES

Seele's Patent, for roses, chrysanthem-
ums, gladioli, tuberoses, dahlias toma-
toes, egg plants, etc. H. D. Seele & Sons,
Maunf., Elkhart, Ind.

POT HANGERS

Pot hangers, Kramer's \$1 doz. by exp.,
\$1.25 by mail. I. N. Kramer & Son, Cedar
Rapids, Ia.

PRIVET

1000' Ligustrum Iboti, 4 ft.; 500 Ligu-
strum vulgaris, 2 to 4 ft.; 1000 Ligu-
strum chinensis, 3 ft., light, \$10 per 1000.
Send for list of large and small shrubs.
Samuel C. Moon, Morrisville, Pa.

RAFFIA

Raffia (colored), 20 beautiful shades
Samples free. R. H. Comey Co., Camden,
N. J.; 810 Washburn Ave., Chicago, Ill.

RHODODENDRONS

John Waterer & Sons, Ltd.,
American Nursery, Bagshot, England.
For page see List of Advertisers.

P. Ouwkerk, Hoboken, N. J.
For page see List of Advertisers.

ROSES

Julius Roehrs Co., Rutherford, N. J.
Rambler Rose, Newport Fairy.
For page see List of Advertisers.

New England Nurseries, Inc., Bedford,
Mass.
For page see List of Advertisers.

Bay State Nurseries, N. Abington, Mass.
For page see List of Advertisers.

Robert Craig Co., Market and 49th Sts.,
Philadelphia, Pa.
For page see List of Advertisers.

Dingee-Conard Co., West Grove, Pa.
New Climbing Rose, Tausendschon.
For page see List of Advertisers.

The Morris Nursery Co.,
Sales Office, 1 Madison Ave., New York.
Ornamental Trees, Evergreens, Hedge
Plants.
For page see List of Advertisers.

F. R. Plerson Co., Tarrytown-on-Hudson,
N. Y.
Hardy Roses for the Garden.
For page see List of Advertisers.

R & J. Farquhar & Co.,
6 and 7 South Market Street, Boston.
For page see List of Advertisers.

ROSES—Continued

The E. G. Hill Co., Richmond, Ind.
Roses, Rhea Reid, American Beauty.
For page see List of Advertisers.

Poehlmann Bros. Co., Morton Grove, Ill.
Roses That Win.
For page see List of Advertisers.

Montrose Greenhouses, Montrose, Mass.
Grafted Stock Bilde, Bridesmaid, Killar-
ney.

Elizabeth Nursery Co., Elizabeth, N. J.
A. T. Boddington, 342 W. 14th St.,
New York.

Roses for Decoration Day, Standard and
Climbing Roses, Spring Specialties.

400 varieties; own roots; summer grown.
Leedle Company, Springfield, Ohio.

Roses, Maid, Bride, Chateaux, Gate, 2
In., \$3.00 100. Valley Greenhouse Co., Se-
wickley, Pa.

Crimson Ramblers, 2 year, on own roots,
extra strong, at 7 cents. Gilbert Costich,
Rochester, N. Y.

Low-budded roses, No. 1, \$95.00; No.
1-1-2, \$65.00 1000. H. T. Jones, Elizabeth,
N. J.

SAGE PLANTS

Good thrifty sage plants from 2-inch pots,
\$1.50 per 100; ready now. Cash with order.
Virginia Nursery Co., Purcellville Va.

SEEDS

T. J. Grey Co., 32 So. Market St.,
Boston, Mass.
For page see List of Advertisers.

Joseph Breck & Sons.
51 and 52 N. Market St., Boston, Mass.
For page see List of Advertisers.

W. Atlee Burpee & Co., Philadelphia.
For page see List of Advertisers.

J. M. Thorburn & Co., 33 Barclay St., N. Y.
For page see List of Advertisers.

A. T. Boddington, 342 W. 14th St., N. Y.
For page see List of Advertisers.

H. F. Micbell Co., 1017 Market St., Phila.
For page see List of Advertisers.

James Vick's Sons, Rochester, N. Y.
Vick's Superb Pansy Seed.
For page see List of Advertisers.

Hjalmar Hartmann & Co.,
12 Stormgade, Copenhagen, Denmark.
Cauliflower and Cabbage Seed.
For page see List of Advertisers.

Rickards Bros., 37 E. 19th St., New York.
For page see List of Advertisers.

R. & J. Farquhar & Co., 6-7 So. Market
St., Boston.
For page see List of Advertisers.

C. C. Morse & Co., 48-56 Jackson St.,
San Francisco, Cal.
For page see List of Advertisers.

H. E. Fiske Seed Co., Faneuil Hall Sq.,
Boston.
Aster Seed.
For page see List of Advertisers.

Brasian Seed Growers Co., San Jose, Cal.
For page see List of Advertisers.

O. V. Zangon, Hoboken, N. J.
For page see List of Advertisers.

Stumpp & Walter Co., 50 Barclay St.,
New York.
For page see List of Advertisers.

Weeber & Don, 114 Chambers St.,
New York.
For page see List of Advertisers.

Altimo Culture Co., Canfield, O.
Aster Seed.
For page see List of Advertisers.

Bloomsdale Seed Farms, Bristol, Pa.
Onion Seed.
For page see List of Advertisers.

Asparagus Pl. Nanns, \$2.50 per 1000.
Plant early. Asparagus Plants 14 to 18
inches high, \$6 per 100. Peter Mack, Box
172, Orlando, Fla.

Davis Perfect and Burrell's Klondike
Cucumber Seed, 85c. per pound. Finest
slicing varieties grown. D. V. Burrell,
Rocky Ford, Colorado.

In writing to Advertisers kindly mention Horticulture

SEEDS - Continued**SEEDS SEEDS SEEDS**

Buckbee's Famous "Full of Life" Pedigreed Strains of the newest and best varietal vegetable and flower seeds, etc. If you have failed to receive a copy of our Spring Trade List write for it today.

H. W. BUCKBEE,

Rockford, Illinois. Rockford Seed Farms. Forest City Greenhouses.

ASTER SEEDS All full weight packets fertile 1907 crop. Express White, Violet, Rose. Trade pkt., 1 1/4 oz., 25c.; 1/4 oz., 75c.; ounce, \$2.50 Queen of Market White, Light Pink, Rose, Lavender, Purple. Trade pkt., 1 1/4 oz., 10c.; 1/4 oz., 5c.; ounce, 50c. Late Branching—White, Pink, Rose, Lavender, Purple. Trade pkt., 1 1/4 oz., 20c.; 1/4 oz., 30c.; ounce, 80c. Carlson's Branching—Pink, Lavender, Early and Late White. Trade pkt., 1 1/4 oz., 25c.; 1/4 oz., 40c.; ounce, \$1.25. Kate Lock White, Daybreak. Same price as Branching. Royal Purple Trade pkt., 1 1/4 oz., 5c.; 1/4 oz., \$1.00; ounce, \$3.00. Violet King—Trade pkt., 1 1/4 oz., 30c.; 1/4 oz., 50c.; ounce, \$1.50. Many other standard sorts in limited quantity. Write if interested. Elmer D. Smith & Co., Adrian, Mich.

SHEEP MANURE

Henry A. Dreer, 714 Chestnut St., Philadelphia.

SMILAX

E. A. Reaven, Evergreen, Ala. Southern Wild Smilax; Log Mosaea. For page see List of Advertisers.

Crowl Fern Co., Milington, Mass.

Smilax, nice young plants, fall sown, 50c. per 100; \$4.00 per 1000. F. A. Baller, Bloomington, Ill.

SPHAGNUM MOSS

Live Sphagnum moss, orchid peat and orchid baskets always on hand. Lager & Hurrell, Summit, N. J.

For a high grade Sphagnum and Green Decorating Moss, different grades of Peat, write for prices and samples. We can give best satisfaction as our stock is well cleaned, well packed. Prompt attention given. American Moss & Peat Co., Box 6, Waretown, N. J.

SPRAYERS

Charles J. Jager Co., 281-85 Franklin St., Boston.

STRAWBERRY PLANTS

C. S. Pratt, Reading, Mass. The Dicky.

Strawberry plants and Asparagus roots (50 varieties). Catalog free. C. Peirce, Dighton, Mass.

STEAM TRAP

E. H. Ippard, Youngstown, O.

VEGETABLE PLANTS

Horse radish sets. Extra fine stock, \$2.50, \$3.50, \$4.50 per 100. Mosbaek Greenhouse Co., Onarga, Ill.

VENTILATING APPARATUS

Pierson U-Bar Co., 1 Madison Sq., N. Y. For page see List of Advertisers.

Foley Mfg. Co., Western Ave., between 25th & 26th Sts., Chicago. For page see List of Advertisers.

John A. Payne, 260-274 Culver Ave., Jersey City, N. J. For page see List of Advertisers.

The Advance Co., Richmond, Ind. For page see List of Advertisers.

Quaker City Machine Co., Richmond, Ind. 20th Century Ventilating Arm. For page see List of Advertisers.

VENTILATING MACHINERY. New Model enclosed, self-oiling gear; Standard Model Open Gear. Lord & Burham, 1133 Broadway, N. Y.

VIOLETS

William Sim, Cliftondale, Mass. Violet Boston.

For page see List of Advertisers.

Violet cuttings, "Marla Louisa" Rhinebeck stock, rooted runners, May delivery \$20.00 M. Wm. F. Kasting Co., 383 Ellicott St., Buffalo, N. Y.

WEEKLY BOARD FILE

A. F. Lewis Mfg. Co., E. Boston, Mass. For page see List of Advertisers.

WITTBOLD WATERING SYSTEM

E. H. Hunt, 76-78 Wabash Ave., Chicago.

WIREWORK

Reed & Keller, 122 W. 25th St., N. Y. For page see List of Advertisers.

Wirework. Write for our catalogue. Holton & Hunkel Co., Milwaukee, Wis.

William E. Heilscher's Wire Works, 28 1/2 Broadway, Detroit, Mich.

The "Just Right" kind. Send for price list. Frank W. Ball, 31 East Third Street, Cincinnati, O.

WOOD MOSS

D. Rusconi, 128 W. 8th St., Cincinnati, O.

WHOLESALE FLORISTS**Boston**

N. F. McCarthy & Co., 84 Hawley St., Boston. For page see List of Advertisers.

H. M. Robinson & Co., 15 Province St. and 9 Chapman Pl., Boston. For page see List of Advertisers.

Welch Bros., 226 Devonshire St., Boston. For page see List of Advertisers.

Buffalo

Wm. F. Kasting Co., 383-87 Ellicott St., Buffalo, N. Y. For page see List of Advertisers.

Chicago

Chas. W. McKellar, 51 Wabash Ave., Chicago. For page see List of Advertisers.

Peter Reinberg, 51 Wabash Ave., Chicago. For page see List of Advertisers.

E. F. Winterson Co., 45-49 Wabash Ave., Chicago. For page see List of Advertisers.

J. A. Budlong, 37-39 Randolph St., Chicago. For page see List of Advertisers.

Detroit

Michigan Cut Flower Exchange, 38 and 40 Broadway, Detroit, Mich. For page see List of Advertisers.

Minneapolis

Rice Bros., 115 N. 6th St., Minneapolis, Minn. For page see List of Advertisers.

New York

J. K. Allen, 108 W. 28th St., New York. For page see List of Advertisers.

J. S. Fenrich, 110 W. 28th St., New York. For page see List of Advertisers.

Ford Bros., 48 W. 28th St., New York. For page see List of Advertisers.

H. E. Froment, 57 W. 28th St., New York. For page see List of Advertisers.

Alex. J. Guttman, 43 W. 28th St., New York. For page see List of Advertisers.

E. C. Horan, 55 W. 28th St., New York. For page see List of Advertisers.

A. H. Langjahr, 55 W. 28th St., New York. For page see List of Advertisers.

James McManna, 42 W. 28th St., New York. For page see List of Advertisers.

John I. Itaynor, 49 W. 28th St., New York. For page see List of Advertisers.

W. F. Sheridan, 39 W. 28th St., New York. For page see List of Advertisers.

Treendly & Schenck, 44 W. 28th St., New York. For page see List of Advertisers.

John Young, 51 W. 28th St., New York. For page see List of Advertisers.

Moore, Hentz & Nash, 55 and 57 W. 26th St., New York. For page see List of Advertisers.

Frank S. Hicks & Co., 52 W. 25th St., New York. For page see List of Advertisers.

Frank Millang, 57 W. 26th St., New York. For page see List of Advertisers.

Wm. H. Knebler, 28 Willoughby St., Brooklyn, N. Y. For page see List of Advertisers.

WHOLESALE FLORISTS—**New York—Continued**

Phillip F. Kessler, 55 and 57 W. 26th St., New York. For page see List of Advertisers.

A. Moltz, 55-57 W. 26th St., New York. For page see List of Advertisers.

B. S. Shinn, Jr., 55 W. 26th St., New York. For page see List of Advertisers.

Millang Bros., 41 W. 23th St., New York. For page see List of Advertisers.

Philadelphia

W. E. McKlasick, 1619-1621 Ranstead St., Philadelphia, Pa. For page see List of Advertisers.

Leo Niessen Co., 1209 Arch St., Philadelphia, Pa. For page see List of Advertisers.

The S. S. Pennock-Meehan Co., 1608-18 Ludlow St., Philadelphia, Pa. For page see List of Advertisers.

Edward Reid, 1526 Ranstead St., Philadelphia, Pa. For page see List of Advertisers.

Pittsburg

J. B. Murdoch & Co., 714 Penn Ave., Pittsburg, Pa. For page see List of Advertisers.

San Francisco

Alex. Mann, Jr., Co., 1125 Polk St., San Francisco, Cal. For page see List of Advertisers.

St. Louis

H. G. Berning, 1402 Plue St., St. Louis, Mo. For page see List of Advertisers.

WHOLESALE PLANTSMAN

Samuel A. Woodrow, 53 W. 30th St., New York. For page see List of Advertisers.

New Offers in This Issue.**CHRYSANTHEMUMS: GERANIUMS.**

Wm. W. Edgar Co., Waverley, Mass. For page see List of Advertisers.

GIANT PRIMULA SEED.

A. T. Boddington, 312 W. 14th St., New York. For page see List of Advertisers.

MOONVINES.

Godfrey Aschmann, 1012 W. Ontario St., Philadelphia. For page see List of Advertisers.

PERENNIAL PHLOX: JAPANESE ANEMONES AND IRIS: TRITOMA PFITZER, ETC.

Henry A. Dreer, 714 Chestnut St., Philadelphia. For page see List of Advertisers.

RELIABLE FLOWER SEEDS.

H. F. Mitchell Co., Philadelphia. For page see List of Advertisers.

RHODODENDRONS.

New England Nurseries, Bedford, Mass. For page see List of Advertisers.

ROOTED CHRYSANTHEMUM CUTTINGS.

H. F. Littlefield, 552 Main St., Worcester, Mass. For page see List of Advertisers.

S. A. F. CONVENTION ACCOMMODATIONS.

Tower Hotel, Niagara Falls, N. Y. For page see List of Advertisers.

SEEDS, PRIMULA FRINGED SINENSIS.

H. E. Fiske Seed Co., 12 & 13 Faneuil Hall Sq., Boston. For page see List of Advertisers.

SPECIAL SALE OF ORCHIDS.

Ordonez Bros., Madison, N. J. For page see List of Advertisers.

TO-BAK-INE.

E. H. Hunt, Genl. Agt., 76-78 Wabash Ave., Chicago. For page see List of Advertisers.

List of Advertisers

Advertiser	Page	Advertiser	Page
Advance, The Co.	510	Lewis A. F. Mfg Co.	533
Aheu J. C.	542	Lord & Burnham Co.	522
Altus Culture Co.	535	Littlefield H. F.	552
American Nursery	531	Lutton W. H.	551
Ameri an Nursery Co.	51	Manda Jos. A.	537
Aschmann G.	537	Maon, Alex. Jr. Co.	540
Atlanta Floral Co.	539	MacMullin E. A.	539
Bambrick Thos. H.	549	McCarthy N. F. & Co.	543
Barrows H. H. & Son	57	McConnell Alex.	538
Baur Floral Co.	517	McKellar Charles W.	540
Bayersdorfer H. & Co	540	McKissick, W. E.	540
Bay State Nurseries	524	McMaous Jas.	542
Beaven E. A.	540	Miami Floral Co.	537
Bernina H. G.	543	Nichell H. F. Co.	534
Bloodsdales Seed Farms	535	Michigan Cut Flower Exchange	543
Boddington A. T.	54	Millang Bros.	543
Boston Florist Letter Co.	539	Millang Fraak	543
Boston Plate and Window Glass Co.	549	Moltz, A.	543
Bosch, Felix	537	Moninger J. C.	551
Bostrum-troy Mfg. Co.	541	Moore Frank L.	550
Bowe, M. A.	538	Moore, Hentz & Nash	513
Braslan Seed Growers Co.	535	Moore, J. L.	531
Breck Joseph & Sons	545	Morris Nursery Co.	531
Brettmeyer's J. Sons	538	Morse C. C. & Co.	545
Bremond Marital	532	Murdoch J. B. & Co.	541
Bridgeman's Seed Warehouse	535	Murray Samuel	538
Budlong J. A.	540	New England Nurseries	531
Burpee W. A. & Co.	535	Niessen Leo. Co.	540
Carrillo & Baldwin	537	Ordonez Bros.	537
Cassidy I.	551	Ouwwerker P.	531
Champion J. N. & Co.	539	Palethorpe P. R. Co.	550
Chicago Carnation Co.	52	Park Floral Co.	538
Clarke's David, Sons	538	Payne John A.	550
Clary's Horticultural Co.	543	Peacock-Meehan Co.	540
Conard & Jones Co.	522	Perkins St. Nurseries	537
Cooke G. H.	538	Peter's Nursery Co.	531
Cowee A.	522	Pierce F. O. Co.	550
Craig, Robt. Co.	531	Pierson, A. N.	522
Dana W. J.	549	Pierson F. R. Co.	544
Dingee & Conard Co.	524	Pierson U Bar Co.	552
Dane Geo. B. & Son	51	Pehlman Bros. Co.	524
Donohoe W. H.	538	Pulverized Manure Co.	550
Dorner F. Sons & Co.	542	Quaker City Machine Co.	550
Dreer H. A.	52	Raynor John I.	42
Dunlop John H.	539	Red Oak Nurseries	522
Dysart R. J.	539	Reed & Keller	543
Eagle Metal & Supply Co.	551	Reid Edw.	540
Edgar, W. W. Co.	532	Reinberg Peter	540
Edwards Folding Box Co.	540	Rice Bros.	50
Elliot Wm. & Sons	530	Rickards Bros.	535
Esler J. G.	530	Robinson H.M. & Co.	541
Ernest W. H.	539	Rock Wm. L. Flo. Co.	538
Eyres	538	Roehrs Julius Co.	524
Farquhar R. & J. & Co.	524	Roland, Thomas	522
Fenrich J. S.	542	Rolker August & Sons	522
Fiske, H. E. Seed Co.	535	Rose Hill Nurseries	531
Foley Mfg. Co.	551	Saader & Son	57
Ford Bros.	542	Schulz Jacob	538
Froment H. E.	542	Scott, John	537
Galvin Thos. F.	539	Sheridan W. F.	547
Grey T. J. Co.	535	Shurtleff J. B. & Son	546
Gude Bros. Co.	538	Siggers & Siggers	541
Guttman Alex. J.	542	Sim, Wm.	513
Haerens A.	521	Situations & Wants	549
Hall Assn.	550	Skidelsky S. S.	522
Haines, J. E.	522	Slinn B. S. Jr.	542
Hart, Geo. B.	539	Smith H. J.	540
Hartmann Hjalmar & Co.	535	Smyth Wm. J.	538
Hauswirth M. C. & J. E.	538	Standard Plate Glass Co.	550
Herbert David & Son	51	Stump & Walter Co.	52
Hews A. H. & Co.	550	Sinaywood Green-houses	550
Hicks Frank S. & Co.	543	Thorburn J. M. & Co.	535
Hilfinger Bros.	550	Totty Chas. H.	531
Hill, The E. G. Co.	524	Towers Hotel	530
Hoffman E. C.	539	Traendly & Schenck	542
Hnran E. C.	542	Valentue, J. A.	538
Houghton & Clark	539	Velthuis K.	537
Hunt E. H.	550	Vick's Jas. Sons	55
Jacobs S. & Sons	551	Vincent R. Jr. & Sons	522
Kasting W. F.	543	Ward R. M. & Co.	532
Kervan Co., The	541	Waterer John & Sons	531
Kessler, P. F.	542	Weatherad Co.	552
King Cons. Co.	551	Weber F. C.	538
Koral Mfg. Co.	530	Weeber & Don	535
Kramer Bros Fdy Co.	532	Welch Bros.	549
Kuebler Wm. H.	543	Wilson	538
Lager & Hurrell	537	Winterson, E. F. Co.	540
Landreth D. Seed Co.	530	Withold Geo. Co.	539
Langehr Alfred H.	542	Woodrow, Sam'l A.	543
LaTribune Horticulte.	531	Yokohama Nursery	537
Leonard I. & J.	522	Young John	542
Leuthy A. & Co.	537	Young, Thos. Jr.	58
		Young & Nugeat	538
		Zangen O. V.	533
		Zinn J. A.	539

GREENHOUSES BUILDING OR CONTEMPLATED.

- Lafayette, Ind.—H. Roth, additions.
 - 9 Ipswich, Mass.—George Lord, house 20x60.
 - Peak's Island, Me.—Mr. Dyer, additions.
 - Woburn, Mass.—M. J. Aylward, rose house.
 - Green Bay, Wis.—Carl Meier, additions.
 - Lexington, Mass.—E. Wood, house 25x160.
 - Red Bank, N. J.—R. K. Fox, conservatory.
 - Bridgewater, Mass.—A. W. Hobart, house 30x100.
 - Sayre, N. Y.—A. L. Merrill, three houses, each 20x145.
 - Springfield, N. Y.—A. F. Johnson, one house.
 - Newport, R. I.—Stewart Ritchie, carnation house.
 - Bay City, Mich.—Boehringer Bros., house 40x100.
 - Mason City, Ia.—Kemble Floral Co., range of houses.
 - Philadelphia, Pa.—Mrs. F. C. Penfield, conservatory.
 - Washington, N. J.—A. J. Bryan, three houses, 28x110 each.
 - Brooklyn, N. Y.—A. Demousey, two carnation houses, 28x145 each.
 - So. Meriden, Conn.—J. W. Davis, two vegetable houses, one 90 feet, one 120 feet.
 - Southboro, Mass.—Miss Caroline B. Ball, two houses, each 30x150; one house, 15x100.
 - Davenport, Ia.—Central Park, three houses, one 12x125, two 22x125 each; Charles Himmell, range of houses.
- LIST OF PATENTS.**
- 883,243. Combined Manure Loader and Spreader. Frank E. Schee, Athens, Mo.
 - 883,244. Row-Marker for Planters. Henry Schrader, Dixon, Ill.
 - 883,268. Manure-Spreader. Dalton K. Wilson, Waterloo, Iowa, assignor to The William Galloway Company, Waterloo, Iowa.
 - 883,365. Wheeled Plow. Ira A. Weaver, Springfield, Ill., assignor to Racine-Sattley Company, Springfield, Ill., a corporation of Illinois.
 - 883,435. Means for Attaching Implements to Cultivator Frames. William E. Walden, Mariette, Okla., assignor of one-half to William S. Hale, Mariette, Okla.
 - 883,493. Combined Planter and Fertilizer-Distributor. George S. Sheffield, Burr Oak, Mich., assignor to Sheffield Manufacturing Company, Burr Oak, Mich.
 - 883,561. Fertilizer Distributer. Washington B. Parrish, Kara, Va.
 - 883,581. Land-Marker. Daniel L. Smith, Wellford, S. C.
 - 883,586. Harrow. Edwin Swope, Morgan Hill, Cal.
 - 883,618. Means for Gathering and Destroying Potato-Bugs. Abraham J. Buhler, Harris, Minn.
 - 883,678. Wheeled Plow. Ira A. Weaver, Springfield, Ill., assignor to Racine-Sattley Company, Springfield, Ill., a corporation of Illinois.

WANTS, FOR SALE, ETC.

Advertisements in this column one cent a word. Initials count as words. Cash with order. All correspondence addressed "care HORTICULTURE" should be sent to 11 Hamilton Place, Boston.

HELP WANTED

FOREMAN WANTED

A man with good experience in Roses and Carnations to take charge of a commercial establishment growing for the wholesale trade.

W. J. DANA

Wellesley Hills, Massachusetts

HORTICULTURE needs a wide-awake representative in every town in the land. Good commission paid on advertising and subscriptions. If you are ambitious, write for terms.

WANTED—A good all around man for greenhouse work and one who has a good knowledge of palms, azaleas, etc. State experience and wages desired. Address Palms, care of HORTICULTURE.

SITUATIONS WANTED

GOOD MEN

When you need good men, skilled or unskilled, Write:

THOS. H. BAMBRICK

34 South 7th Street Philadelphia

Help of all kinds, including that of Florists, Nurserymen, Seedsmen and Horticultural trade generally.

SITUATION WANTED In general greenhouse work; single, age 35, five years' experience, commercial. Address W. W., care HORTICULTURE.

FOR SALE

FOR SALE—A large consignment of 16x24 double thick American glass, A and B quality. For further information write Parschelsky Brothers, 59 Montrose Avenue, Brooklyn, N. Y.



DREER'S

Florist Specialties. New Brand New Style. HOSE "RIVERTON"

Furnished in lengths up to 500 ft. without seam or joint.

The HOSE for the FLORIST

3/4-inch, per ft., 15 c.
 Reel of 500 ft., " 14 1/2 c.
 2 Reels, 1000 ft., " 14 c.
 1 1/2-inch, " 13 c.
 Reels, 500 ft., " 12 1/2 c.

Couplings furnished. HENRY A. DREER, 714 Chestnut St., PHILADELPHIA, PA.

BOSTON PLATE & WINDOW GLASS CO.

GREENHOUSE GLASS

German and American

261 to 287 A St., Boston 20-22 Canal St.

Is Your Name In The Above List? If Not, Why Not?

A Good Thing

between faucet and jet is



HOSE

Tested for years and adopted by the

Sunnywoods Greenhouses

(The place of origin of the rose BRIDESMAID)

MADE IN TWO BRANDS:

Sunnywoods
and
Sunnywoods Extra

In two sizes:—three-quarter and half-inch In two lengths:—50 ft. and 30 ft. (Both sizes have 3/4 inch couplings)

PRICES.

"Sunnywoods" — 3/4 inch, 16c.; 1/2 inch, 15c. per ft.
"Sunnywoods Extra" — 3/4 inch, 17c.; 1/2 inch, 16c. per ft.

The material of both brands is of the best. The "Sunnywoods Extra" is the heavier of the two brands.

For the purpose of introduction, this special offer is made:

If you send cash with your order, deduct one cent per foot from the price. And on all cash purchases of more than one hundred feet, freight will be prepaid.

FRANK L. MOORE
CHATHAM, NEW JERSEY
NEW YORK OFFICE, 57 West 26th Street

DON'T EXPERIMENT
USE

TOBAKINE

and your stock will be free from insects, clean, and the blooms will not be discolored.

Send for full information of

W. W. RAWSON & CO.,
5 Union St., Boston.

STUMPP & WALTER CO.,
50 Barclay St., New York.

HENRY F. MICHELL & CO.,
1018 Market St., Philadelphia.

E. H. HUNT, Gen'l Agent,
76-78 Wabash Ave., Chicago.

There are some
GOOD BARGAINS
listed in the
BUYERS' DIRECTORY,
Pages 544 to 548 this week.

GREENHOUSE GLASS

Cheaper Now Than For Years

We are taking contracts for next Spring delivery.

WRITE FOR OUR PRICES

STANDARD PLATE GLASS COMPANY

26-30 Sudbury St. 61-63 Portland St.
BOSTON, MASS.



STANDARD FLOWER POTS

Packed in small crates, easy to handle.

Price per crate		Price per crate	
1500 2 1/2 in. pots in crate	\$4.88	120 7 in. pots in crate	\$4.20
1500 3 1/4 " " "	5.25	60 8 " " "	3.00
1500 2 3/4 " " "	6.00	HAND MADE	
1000 3 " " "	5.00	48 9 in. pots in crate	\$3.60
800 3 3/4 " " "	5.80	48 10 " " "	4.80
500 4 " " "	4.50	24 11 " " "	3.60
320 5 " " "	4.51	24 12 " " "	4.80
144 6 " " "	3.16	12 14 " " "	4.80
		6 16 " " "	4.50

Seed pans, same price as pots. Send for price list of Cylinders for Cut flowers, Hanging Baskets, Lawn Vases etc. Ten per cent. off for cash with order. Address Hillinger Bros., Pottery, Fort Edward, N.Y. August Rolker & Sons, Agts., 31 Barclay St., N. Y. City.



The Best Bug Killer and Bloom Saver

For PROOF
Write to

P. R. Palethorpe Co.
DOWNSBORO, KY.



Cattle Manure In Bags

Shredded or Pulverized
Best and safest manure for florists and greenhouse use, absolutely pure, no waste, no danger. Write for circulars and prices.

The Pulverized Manure Co.,
31 Union Stock Yards, Chicago

JOHN A. PAYNE

Greenhouse Designer and Builder

260-274 Culver Ave., Jersey City



THE
PAYNE

Galvanized Iron non-freezing Z Bar Eaves Plate is acknowledged to be the best and the most durable. No inside drip, no

sockets to hold moisture around wood bars.

Iron and wood frame greenhouses of every type—material only or erected.

LET US ESTIMATE.

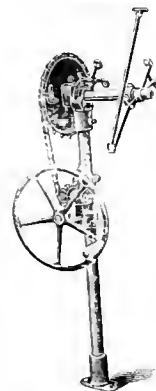

The Advance Ventilating Apparatus

has pleased every customer in 38 states, because it does its work easily, is easy to erect, will last a lifetime and is sold at right prices. Get our new price list.

The Advance Co.
RICHMOND, IND.

MASTICA

FOR Greenhouse Glazing

USE IT NOW.
F. O. PIERCE CO.
12 W. Broadway and
227 Greenwich St.
NEW YORK

Evans 20th Century Arm

Will not twist your shafting pipe. Give it a trial and you will use no other. Three times the power of elbow arms.
Write for Catalogue

QUAKER CITY MACHINE CO.
Richmond, Ind.

Standard Flower POTS

If your greenhouses are within 500 miles of the Capitol, write us, we can save you money

W. H. ERNEST

28th and M Street WASHINGTON D. C.

The FLORISTS' HALL ASSOCIATION OF AMERICA, insurer of 28,000,000 sq. ft. of glass. For particulars address John C. Esler, Sec'y, Saddle River, N.J.

WILLIAM H. LUTTON

HORTICULTURAL ARCHITECT AND BUILDER

WEST SIDE AVENUE STATION (C. R. R. OF N. J.)
JERSEY CITY, N. J.

Have not been established 50 years, but long enough to convince the wide-awake Florist and Gardener that it is to his interest to place his work in thoroughly practical hands.

(150,000 sq. ft. glass erected in 1907 will substantiate this claim)

And why not? My material is the best that can be secured. My iron frame construction has every modern feature that years of practical experience can embody.

AND THEN THERE IS THE COST TO BE CONSIDERED.

Why not let us take up this important question now?

IRON PIPE

SECOND HAND

WROUGHT IRON PIPE, for Steam, Water, Gas or Oil, Fences or Posts. All Sizes. Price Low.

GEO. B. DOANE & SON
 18 Midway Street, BOSTON
 Telephone, Main 4419

ISAAC CASSIDY

Summer Ave. & Erie R.R., Newark, N. J.

Write for Prices

**GREENHOUSE MATERIAL
 CONSTRUCTION FITTINGS**

Bench Fittings

Material Furnished and Erected

R. TONAWANDA, N. Y.

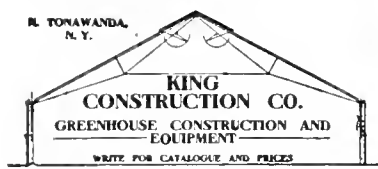

**GREENHOUSE CONSTRUCTION
 LUMBER**

John C. Moninger Co.
 117 E. Blackhawk St., CHICAGO

Holds Glass Firmly
 See the Point FULL SIZE N. 2

PEERLESS
 Glazing Points are the best. No rights or lefts. Box of 1,000 points 75 cts. postpaid.
HENRY A. DEER,
 714 Chestnut St., Phila., Pa.

THE FOLEY MFG. CO.

CHICAGO

Completely equipped with up-to-date machinery for the making of material for

GREENHOUSE CONSTRUCTION

From a Full Supply of Thoroughly Seasoned Lumber

Send your sketches to our draughtsmen for completion and suggestion. Permit us to figure your proposed work, large or small.

We guarantee our prices will save you money

FOLEY VENTILATING APPARATUS IS THE BEST

Simple in Erecting. Is Easiest of Operation. It Will Last a Lifetime. Its Price is the Lowest. Will Ventilate Any Size House. Prices and Circulars on Application.

Our 1908 Catalogue Greenhouse Material Sent Postpaid on Request.

**THE FOLEY MFG. CO., WESTERN AVENUE
 25th and 26th STS., CHICAGO**

PATENTS

Trademarks and Copyrights

Send your business direct to Washington. Saves time and insures better service. Personal attention guaranteed. Twenty-five years' active service. SPECIALTY: "Working on the Failure of Others."

SIGGERS & SIGGERS

PATENT LAWYERS

Box 9, National Union Building
 Washington, D. C.

S. JACOBS & SONS
 Manufacturers of GULF CYPRESS

GREENHOUSE MATERIAL

HOT-BED-SASH & FRAMES
 Jobbers in Boilers-Pipe-Fittings and

GLASS on which we can quote attractive prices. Disc on large quantities. We furnish everything for Greenhouse Building
**1365-1379 Flushing Avenue
 BROOKLYN, - NEW YORK**

CYPRESS SASH BARS
 82 feet or longer
HOT BED SASH

PECKY CYPRESS BENCH LUMBER

GREENHOUSES

ERECTED AND EQUIPPED COMPLETE IF DESIRED

Write for Circular "D" and Prices

The A. T. STEARNS LUMBER CO.
 NEPONSET, BOSTON, MASS.

In writing advertisers kindly mention HORTICULTURE.

SECOND HAND PIPE & BOILER TUBES

Of all sizes, in good condition, suitable for steam purpose, coupled and threaded, for sale at low rates.

5000 feet 1 inch pipe, 3c. per ft.; 5000 feet 1 1/2 inch pipe, 4c. per ft.; 3000 feet 1 3/4 inch pipe, 5c. per ft.; 2000 feet 2 inch pipe, 6 1/2c. per ft.

EAGLE METAL & SUPPLY CO.,
 Johnson and Union Aves. BROOKLYN, N. Y.

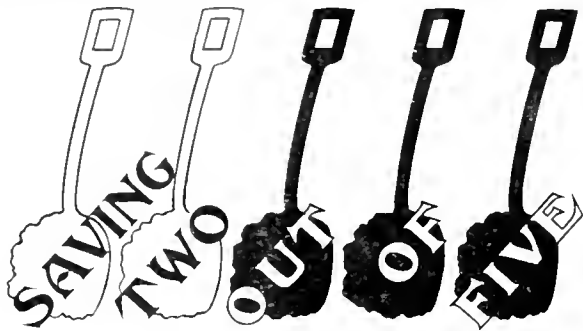

By using the

Spencer Water-Jacketed Magazine Feed Boiler

Not only the greatest coal saver, but the least firing. Runs 24 hours in moderate weather or 12 hours in severest weather with drafts on. Burns Pea or No. 1 Buckwheat coal.

WEATHERED COMPANY, Sole Agents

Don't forget our catalogue — the houses of greatest sunlight — Iron Frame, Semi-Iron Frame or all wood, erected or materials only

P. O. ADDRESS, BOX 789 N. Y. CITY

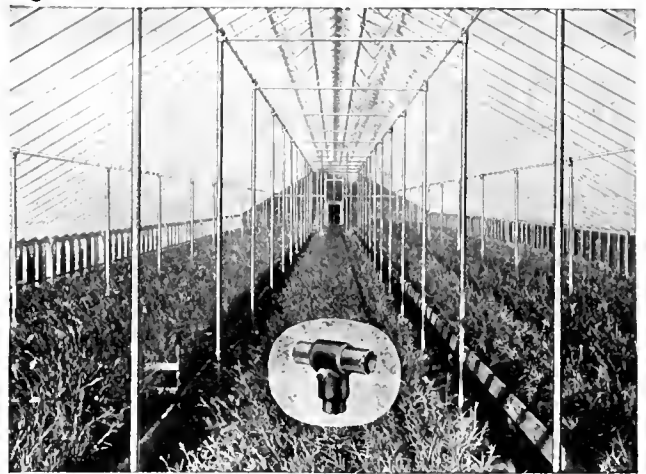

Our SEMI-IRON Greenhouses

have a Pipe and Clamp Frame, Pipe Purlins, Pipe Columns and Cast Iron Foot Pieces, Clamp Column Fittings, Iron Posts and Galvanized Ice-Clearing Eave. It is the house with our famous Giant Arch. Send for circular.

WE MAKE EVERY PART OF A GREENHOUSE BUT THE GLASS. WE SELL ANY PART.

LORD & BURNHAM CO.

MAIN SALES OFFICE:
1133 BROADWAY, NEW YORK

BOSTON: 819 Tremont Building
PHILADELPHIA: 1215 Filbert St.

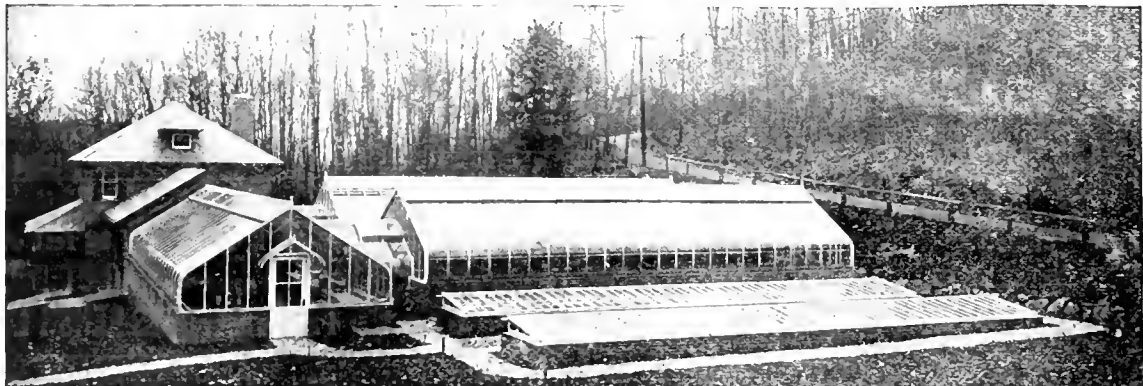

WHERE AVAILABLE SPACE COUNTS

Here is a range of U-Bar houses erected at Tuxedo Park. You can see that the available ground space is somewhat limited by the existing roads. In such a location, every bit of bench room must count to best possible advantage; each house be equally efficient. No other houses meet these demands like the U-Bar, because of its extreme lightness, giving to each house much more light than other constructions. Send for catalog, it shows you why

U-BAR GREENHOUSES

PIERSON
DESIGNERS AND BUILDERS



U-BAR CO.
1 MADISON AVE., NEW YORK

HORTICULTURE

Vol. VII. APRIL 25, 1908 No. 17



EARLY WHITE SWEET PEA "WATCHUNG."
At Wm. Sim's, on 12-foot trellis.

*Devoted to the
FLORIST, PLANTSMAN,
LANDSCAPE GARDENER,
and
Kindred Interests*

*Published
EVERY SATURDAY
At 11 Hamilton Place,
BOSTON, MASS.
Subscription, \$1.00*

APR 25 1908

CANNA BULBS

Fine plump, Northern Grown, and in fine condition. Not to be compared with Southern grown stock, that are never thoroughly ripened and therefore are very slow to start growing.

	Doz.	100	1000		Doz.	100	1000		
Allemania	\$0.35	\$2.50	\$22.50	Gladiator	\$0.40	\$3.00	\$27.00
Black Prince40	3.00	27.00	King Edward50	3.50	32.00
Black Warrior35	2.50	22.50	Louisiana55	4.00	35.00
Burbank30	2.25	20.00	Mad. Crozy40	3.00	27.00
Black Musafolia40	3.00	27.00	Mlle. Berat30	2.25	20.00
Charles Henderson35	2.50	22.50	Musafolia30	2.25	20.00
Director Roetz35	2.50	22.50	Paul Marquant30	2.25	20.00
Flamingo30	2.25	20.00	Pres. McKinley35	2.50	22.50
Florence Vaughan35	2.50	22.50	Queen Charlotte35	2.50	22.50
Golden Star30	2.25	20.00	Robusta30	2.00	18.00
					Red Cross30	2.25	20.00

STUMPP & WALTER CO., 50 Barclay St., NEW YORK

GERANIUMS

A splendid stock of fine plants in 2 inch pots, good standard sorts and new varieties at \$2.00 per 100 and up to \$1.00 each. We will send 1000 in 20 good varieties, our selection, for \$18.50. Our special descriptive Geranium Catalogue, describing over 250 varieties of Geraniums and Pelargoniums mailed free to the trade.

NOVELTIES

1007 introductions, from Bruant, Lemoine, Bouchalat and Cannell, one each of 50 varieties our selection, including single and double, for \$5.00.

PELARGONIUMS

In good variety, strong plants from 3 inch pots at \$1.50 per dozen, \$6.00 per 100.

HARDY CHRYSANTHEMUMS

Our collection of Hardy Chrysanthemums will compare favorably with any in the country and we have an immense stock ready for shipment. Small flowered or Button Varieties, \$2.00 per 100. Large Flowered or Aster Varieties, \$3.00 per 100. Description will be found in our Wholesale List.

DAHLIA ROOTS

We still have about 75 varieties we can offer in Cactus, Decorative, Show and Pompon true to name at \$5.00 per 100 and up for Whole Field-grown clumps. One thousand, 50 each of 20 varieties, our selection, for \$40.00, all good kinds; a splendid collection for planting or just the thing for Store Trade.

	Per 100		Per 100
Alyssum, Giant Double	\$2.00	Hardy Phlox	2.00
Ageratum, Stella Gurney	2.00	Hollyhocks, Strong 3 in. pot plants, dbl. white, pink, red and yellow	3.00
Begonia, Vernon, White and Rose	2.00	Ivy Leaved Geraniums, 6 good kinds, \$25.00 per 1000	3.00
" Gracilis, White and Rose	2.00	Lobelia, Crystal Palace Gem	2.00
Begonias "Rex" from 2 in. pots	2.00	" Kathleen Mallard, 2 inch	3.00
Cuphaea, Cigar Plant	2.00	Lavender, 2 1/2 in. pots strong	3.00
Coleus, Verschaffeltii, Golden Bedder and other kinds	2.00	Swainsona, Alba	2.00
Fuchsias, Black Prince and Minnesota	2.00	Salvia Bonfire and Splendens	2.00
Lieutenant Muritz, White and Rose Phenomenal	2.50	Tradescantia, Dark Variegated	2.00
Hardy English Ivy, Extra Strong, \$15.00 per 1000	2.00	Verbena, Red, White, Purple and Pink	2.00

R. VINCENT JR. & SONS COMPANY, White Marsh, Md.

YOU WANT THEM NOW

Before the cream of the varieties is all sold. The finest stock of standard

HARDY PERENNIALS

in the country. Write and we'll quote tempting prices.

Red Oak Nurseries, Fiskeville, R. I.

AZALEAS

for fall delivery, the best that are grown, also PALMS for spring or fall delivery, furnished by August Haerens, Somergem, Belgium; orders booked now.

ADDRESS THE AMERICAN REPRESENTATIVES
AUGUST HAERENS & SONS, 31 Barclay Street, or P. O. Box 752, New York

CANNAS

Send for our List and Prices

The CONARD & JONES CO. WEST GROVE, PA.

WHY send away for worthless dry bulbs when you can gain time and save money by buying at home. Cannas all started for \$2.00 per 100. Austria, Robusta, Pennsylvania, Italia, Chas. Henderson, Mlle. Berat and Pres. Carnot.

J. B. SHURTLIFF & SON, Cushman Ave., Revere, Mass.

JOHN E. HAINES Bethlehem, Pa.

is the place to order rooted-cuttings of the following varieties for 1908.

	Per 100	Per 1000
John E. Haines, red Imperial variegated	\$6.00	\$50.00
Pink Imperial, Pink Enchantress, Light Pink		

Place your orders early for Jan. delivery.

Carnation Cuttings

Both standard varieties and novelties. Stock guaranteed to be first-class. Address,

S. S. SKIDELSKY

1741 North 18th Street, Philadelphia

COLEUS

Verschaffeltii, Golden Queen, Fire Brand, Lord Palmerston, Queen Victoria, Beckwith's Gem. Prices of Rooted Cuttings by express, 60c. per 100; \$5 per 1000. Less than 250 of a variety will be charged at the 100 rate.

Golden Bedder, Hero, Tessey, Pearl of Orange, 75c. per 100; \$6 per 1000. Less than 250 of a variety will be charged at the 100 rate.

Fancy Varlet-es. A very fine assortment of twelve kinds not listed above, 75c. per 100; \$6 per 1000, 250, in assortment, our selection, at the 100 rate.

MISCELLANEOUS PLANTS

AGERATUM, Stella Gurney, Princess Pauline. SALVIA Splenders, Bonfire. HELIOTROPE. Rooted cuttings, 75c. per 100; \$6 per 1000.

CARNATIONS

	100	1000
Winsor	\$6.00	\$50.00
White Perfection	2.50	20.00
Rose Pink Enchantress	3.50	30.00
Enchantress	2.50	20.00
Queen Louise	2.50	20.00

From 2 1/4 inch pots, add \$1.00 per 100.

ASPARAGUS PLUMOSUS NANUS SEEDLINGS From flats, \$1.00 per 1000.

CHRYSANTHEMUMS

Standard varieties, ready for shipment. Rooted cuttings, \$2 per 100; \$15 per 1000. Seed for list.

A. N. PIERSON, CROMWELL, CONN.

GLADIOLI

I can satisfactorily supply your wants for Gladioli for forcing or outdoor planting. Mixtures, color sections or named varieties of exceptional beauty.

Write for Prices

ARTHUR COWEE

Gladiolus Specialist

Meadowvale Farm, BERLIN, N. Y.

GLADIOLUS BULBS

100,000, from 1 1/4 inches up @ \$1.00 per 1000

100,000, 3/4 to 1 1/4 inches @ \$2.00 per 1000

Cash with order. Description given on request. Nice block of California Privet, \$1.00 per 1000 and up, as to quality. Write for particulars. Nice lot of American Chestnut Trees at a bargain. Thirty-five large Sugar trees, most of them sample trees.

I. & J. L. LEONARD, IONA, N. J.

CARNATIONS

WINONA—The True Pink \$12.00 per 100, \$100.00 per 1000

	Per 100	Per 1000
Red Chief	\$5.00	\$40.00
Aristocrat	6.00	50.00
Winsor	6.00	50.00
Beacon	6.00	50.00
White Perfection	3.00	25.00
Rose Pink Enchantress	3.00	25.00
Enchantress	3.00	25.00
Lady Bountiful	3.00	25.00

F. DORNER & SONS CO., LAFAYETTE, IND.

ROOTED

CARNATION CUTTINGS

Only the Best Varieties

CHICAGO CARNATION CO., JOLIET, ILL.

ROOTED CHRYSANTHEMUM CUTTINGS

Glory of the Pacific, Polly Rose, Ada Byron, Kalb, Halliday, Harry Sinclair Bonington, \$1.50 per 100.

Fair Maid Carnation Cuttings \$1.00 per 100; \$8.00 per 1000.

H. F. Littlefield, 552 Main St., WORCESTER, MASS.

DREER'S SEASONABLE SPECIALS

Hardy Perennial Phlox

We are Headquarters for these. More than one hundred and fifty thousand one year old field grown plants now in pots.

Collection of Choice Standard Phloxes

- Aquillon** (Tall). Bright Tyrian Rose with crimson-red eye.
- Andreas Hoffer** (Medium). An early and continuous pure white.
- Bonquet Henri** (Dwarf). Pure white with crimson-carmine eye; free-flowering; each branch a perfect bouquet.
- Bridesmaid** (Tall). White, with large crimson-carmine centre.
- Beranger** (Dwarf). Ground color white, delicately suffused with rosy pink and distinct amaranth-red eye.
- Bacchante** (Tall). Tyrian rose with crimson-carmine eye.
- Clara Benz** (Dwarf). Lovely carmine rose, with deeper eye.
- Champs Elysee** (Medium). A very bright rosy magenta of an effective shade.
- Eclairer** (Tall). Brilliant rosy magenta with large lighter halo; an excellent variety.
- Eugene Dauzanvillier** (Tall). Lilac, shading white toward the edges; large white centre.
- Escarmoude** (Tall). Lilac marked with white, aniline-red eye.
- Graff von Ungerer** (Tall). Large flower; white suffused throughout with rosy lilac and dark crimson centre.
- H. O. Wijers** (Tall). Pure white, with crimson-carmine eye.
- Henry Burger** (Tall). White with crimson-carmine centre.
- Inspector Peiker** (Tall). Purplish mauve, washed with white.
- Jeanne d'Arc** (Tall). A late-flowering pure white.
- La Yague** (Medium). Pure mauve with aniline-red eye; one of the best Phlox in our collection.
- Otto Thalakker** (Dwarf). Tyrian rose with red eye and light halo.
- Obergaister Wittig** (Medium). Bright magenta, with crimson-carmine eye; large flower and truss, the best of its type.
- Partheon** (Tall). Bright carmine rose.
- Pecheur d'Irlande** (Tall). Crimson red, suffused with cochineal-red and carmine red eye.
- Pacha** (Dwarf). Deep rose pink suffused with solferino-red and carmine-purple eye.
- Professor Schlieffman** (Tall). Fore mauve with crimson-carmine eye; an effective late flowering variety.
- Papillon** (Medium). Bright violet purple, marked with white.
- R. P. Struthers** (Tall). Rosy carmine with claret red eye; one of the best Phlox in cultivation.
- Sunshine** (Dwarf). Large flower, aniline-red with crimson-red eye and light halo.
- Thebaide** (Dwarf). Carmine lake with brighter shadings and aniline red eye.
- Von Goethe** (Tall). Tyrian rose, suffused with carmine lake and carmine red eye.

Price choice standard varieties—Strong, one year-old field-grown plants, 75c. per doz.; \$3.00 per 100; \$30.00 per 1000.

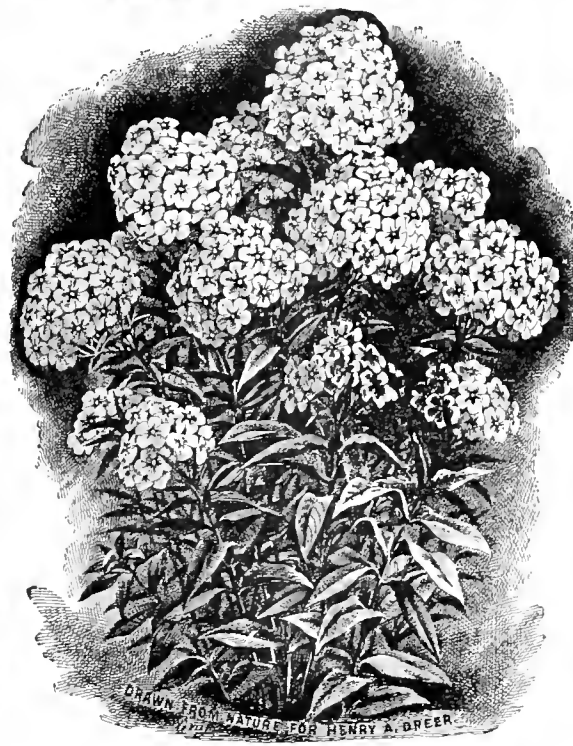

Hardy Phlox

New and Rare Hardy Phloxes

	Pr 100	Pr 1000
Ablon . A variety which originated with us several years since. It is a remarkably strong, vigorous grower, producing very large panicles of pure white flowers with a faint aniline red eye. An excellent sort for massing.....	\$6.00	\$50.00
B. Comte (Tall). A glowing reddish or French purple; one of the finest dark-colored varieties.....	6.00	50.00
Coquelicot (Dwarf). A fine pure scarlet with crimson-red eye.....	6.00	50.00
Etna (Medium). Crim.-red suffused with fiery-red; cherry-red eye.....	6.00	50.00
F. G. von Lassburg (Tall). The finest white in cultivation, the individual flowers being fully double the size of any other variety, pure in color; a strong, clean, vigorous grower.....	10.00	100.00
Hermine (Dwarf). The dwarfiest variety in our collection, never exceeding ten inches in height; pure white flowers of good size; early; unequalled for bordering; a perfect little gem.....	6.00	50.00
Inspector Elpel (Tall). Tender rose, with bright crimson-carmine eye.....	6.00	50.00
Jules Gambon (Medium). Very large, reddish purple, with exceptionally large pure white centre, the brightest and most distinct of this type.....	10.00	100.00

	Pr 100	Pr 1000
Le Mahdi (Tall). Reddish violet with darker eye.....	6.00	50.00
Mrs. Jenkins (Tall). An early-flowering, pure white, forming an immense panicle; one of the best.....	10.00	90.00
Michael Cervantes (Tall). Pure white with pure red eye; large flower.....	6.00	50.00
Selma (Tall). Large flower, pale rose mauve, with distinct claret-red eye.....	10.00	90.00
Venusius (Medium). Bright pure red, with French-purple eye; rich and gay.....	6.00	50.00

JAPANESE ANEMONES Not the winter killed or dried up cellared stock so often seen, but established growing plants from three inch pots which will flower early and continuously, one of the most valuable subjects to plant for late summer and fall cut flowers. We offer the following choice varieties.

	per doz.	per 100	per 1000
Japonica . Rosy red,	\$.85	\$6.00	\$50.00
" Alba. Pure white,	.85	6.00	50.00
" Elegantissima. Semi double satiny rose,	1.25	8.00	70.00
" Lord Ardilaun. Large single white,	1.25	8.00	70.00
" Prince Henry. Double deep rich pink,	1.25	8.00	70.00
" Queen Charlotte. Large double silvery pink,	.85	6.00	50.00
" Rosea Superba. Delicate silvery rose,	.85	6.00	50.00
" Whirlwind. Large semi-double white	.85	6.00	50.00

Japanese Iris—Iris Kaempferi. The stock which we offer is of our own growing, not newly imported, therefore absolutely free of mixtures. We offer twenty distinct varieties and recommend these as a valuable early summer flower.

Named Varieties Strong Roots, \$1.50 per dozen; \$10.00 per 100; \$75.00 per 1000
Choice Mixture " " 0.85 " 6.00 " 50.00 "

Tritoma Pfitzeri—The Everblooming Red-Hot Poker or Flame Flower. We have a good supply of this flowering variety which is so valuable as a decorative cut flower for late summer and fall use. We offer strong roots, \$1.00 per dozen; \$7.00 per 100; \$60.00 per 1000.



Tritoma Pfitzeri

HENRY A. DREER,

714 Chestnut St., Philadelphia, Pa.

HARDY ROSES FOR THE GARDEN

Strong Field-grown Plants

The roses here offered are extra strong two-year-old field-grown blooming plants, which if planted early, will give a large number of flowers the first year. They can be planted as early in the spring as the frost is out of the ground, and from that time until about the first week in May. We offer a grand collection of the best and choicest varieties, as follows:

HYBRID PERPETUAL OR JUNE ROSES

Frau Kari Druschki, Marchioness of Londonderry, Capt. Hayward, Mrs. R. G. Sharman-Crawford, Ulrich Brunner, Margaret Dickson, Baron de Bonstetten, Paul Neyron, Gen. Jacqueminot Magna Charta, Mrs. John Laing, Mme. Gabrielle Luizet, Marshall P. Wilder, Gloire de Paris, Baroness de Rothschild, Prince Camille de Rohan, Fisher Holmes, Alfred Colomb, Soleil d'Or, Persian Yellow, Moss Roses, Rugosa alba and rubra, etc.

MONTHLY AND HYBRID TEA ROSES

Etoile de France, Killarney, Mme. Abel Chatenay, Countess of Gosford, Koenigen Carola, Perle von Godesberg, Gruss an Teplitz, Maman Cochet, White Maman Cochet, Belle Siebrecht, Hermosa, Mme. Caroline Testout, Souv. de Pres. Carnot, Kaiserin Augusta Victoria, American Beauty, La France, Clothilde Soupert, P. Ince de Bulgarie, Mme. Norbert Levavasseur (Baby Rambler), Anny Muller (Pink Baby Rambler), Catherine Ziemet (White Baby Rambler), etc.

In Climbing Roses we have a nice stock of Crimson Rambler, Lady Gay, Dorothy Perkins, Dawson, Gardenia, Tausendschon, etc.

LET US KNOW THE QUANTITY YOU WANT AND VARIETIES, AND WE WILL BE GLAD TO QUOTE LOWEST PRICES ON SAME BY RETURN MAIL.

F. R. PIERSON CO., Tarrytown-on-Hudson, New York

ROSES

100 of the best Hardy sorts.

HYBRID PERPETUALS

Finest English Grown Plants

Dozen, \$3.50; 100 \$25.00

EVERBLOOMING HYBRID TEAS

Bloom from Midsummer until frost.

Dozen \$5.00; 100, \$35.00

Hardy Climbing Roses

All the leading sorts.

Catalogue Free on Application.

R. & J. FARQUHAR & CO.

6 and 7 So. Market Street,
Boston, Mass.

FORESTRY PLANTING

10,000 Red Oak, 4 to 7 in. \$50. Ornamental Planting. Swiss Stone Pine, 3 yrs, 3 to 4 in. \$3 per 100, \$25 per 1000. Foxtail Pine, 3 yrs, 3 to 4 in. \$4 per 100. Balfour Pine, trans., 4 and 5 in. \$5 per 100. Mugho Pine, trans., 6 to 8 in. \$6 per 100. Compacta Mugho Pine, dwarf, trans., 3 to 4 in., broad \$7 per 100. Hemlock, 6 to 8 in., trans. \$4 per 100. Larger sizes of all of above. Am. Yew, 10 to 12 in., trans. \$16 per 100. Specimen of Caroline Hemlock, R.K. Mt. Spruce, R.K. Mt. Silver Fir, 2 1/2 to 4 ft. \$10 to \$4.
JACKSON'S NURSERIES, Portland, Me.

TAUSENDSCHON

or in English **Thousand Beauties**, is the sensational new Climbing Rose of the year. Every florist should have it. It is not excelled for forcing purposes and for general planting by any Climbing Rose now known, **not even baring Crimson Rambler**. This is the coming forcing Rose. Get your stock early. Illustrated in ten colors and gold in our Catalogue for 1908, the **Leading Rose Catalogue of America**. Every Rose worth having is described in it. Copy free for the asking.

Strong plants of Tausendschon from 3-inch pots, 10 for \$1.50; \$12.00 per 100; \$100.00 per 1000.

THE DINGEE & CONARD CO., WEST GROVE, PA.

HARDY NORTHERN GROWN NURSERY STOCK

At Reasonable Prices

FRUIT AND ORNAMENTAL TREES, SHRUBS, VINES, ROSES AND HERBACEOUS PERENNIALS IN GREAT VARIETY

Catalogue and Price List for the asking

BAY STATE NURSERIES, NORTH ABINGTON, MASS.

NEW ——— NEW

RAMBLER ROSE "NEWPORT FAIRY"

To be disseminated Spring, 1908. Ask for illustrated pamphlet and prices

JULIUS ROEHRS CO., Rutherford, N.J.

The Roses that Win

MRS. POTTER PALMER, CARDINAL American Beauty and Other Standard Varieties. Rooted from Our Famous Stock. Send for Prices.

POEHLMANN BROS. CO.
Morton Grove, Ill.

RHEA REID

READY NOW, Own Root, \$30 per 100, Grafted, \$35 per 100.

AMERICAN BEAUTY

Fine Young Stock, \$6 per 100, \$50 per 1000.

THE E. G. HILL CO., Richmond, Ind.

The Present Importance of Hardy Perennials

When as far as fifty years ago an experienced gardener and general horticulturist in mature years frankly admitted that his days of learning never ceased his fellow craftsmen perhaps thought him a modest, unassuming gentleman. In our present age of specialization and consequent rapid development, when even the specialist, unless he is open-eyed and ever alert, is apt to become rusty, we consider such utterances as solely sensible and nothing more. A strong pretension as to practical mastery of the whole field arouses the reasonable doubts of the serious-thinking and is taken with indulgence by the optimistic listener. Professional training on a broad scale and subsequent practical experiences in the various branches of horticulture can not be valued too highly, still initiative power and innate capacity to quickly grasp the essentials of a new situation are equally important. The former are the main resources of the grower, while the success in the management of a large concern to a greater extent depends on the latter qualities. There are always a number of horticulturists who by virtue of extraordinary results have proven themselves in more than one department equal to the specialist; still human faculties are limited, while the present horticultural possibilities appear well nigh unlimited, hence the ever present necessity for the gardener to learn. One of the floricultural branches which today should be made a general object of study is the growing and the advantageous use of perennials. Not alone the fact that we have comparatively few specialists with thorough and comprehensive knowledge of the vast number of species of this class of plants, but also the frequent lack of effective



DELPHINIUMS
A Revelation of Beauty.

arrangement and the want of proper care are evidences for an urgent need of learning for many of us.

A COMMON MISCONCEPTION

It seems that in the opinion of quite a number of gardeners the hardy perennial is still a side issue of little or no consequence. I should be glad to hear I was mistaken, for indifference toward such an important branch is today, to say the least, untimely. How often is in the imagination of garden owner and even gardener the planting of a herbaceous border first and last a labor saving scheme. "Perennial flowers thrive in any sort of soil and need very little care. They come up and spread out year after year and save the bother of raising a lot of annuals needing watering and hoeing and constant looking after." When, then, this very border, after a prolonged drought, without ground cultivation and irrigation, turns to be an eyesore instead of an ornament the disappointment is complete. "It looks so unsightly, scrubby and shabby and is not fit for a garden at all."

Indeed the perennial flower border as a labor saving scheme had better never be planted, for it is detrimental to the interests of the firm that furnishes first-class plant material, it reflects badly on both garden and caretaker, and in the given shape, constitutes a serious obstacle in the path of our general horticultural advancement. More thoroughness in the preparation of the ground before planting and a liberal amount of care afterward is my advice—to those who wish to derive credit and pleasure out of their herbaceous plantations.

CARE IN GROUPING

Among the multitudes of patrons and visitors year after year a lady last summer, when placing her orders for a number of recent introductions of perennials asked



SPIRÆA FILIPENDULA

to have her goods shipped at a certain date. "I wish to be present at the planting. My gardener is in the habit of scattering everything singly over the whole garden and I like to have the species and varieties grouped together by themselves. They show to better advantage and it saves me walking all over the place when cutting flowers. This incident is not a singular one. Its frequency shows the lack of understanding of effective arrangement. One plant of delphinium is handsome, but a clump of them, their tall erect spikes standing out in vivid contrast against a dark evergreen background, is a revelation of floral beauty to the eye. Japanese irises when planted singly among other herbaceous plants are very attractive indeed; still associated in a mass by themselves their character of growth and their marvelous richness in form and hue is more impressive; their flowering season becomes a special feature of the floral display of a season.

In response to a summons of a cottage owner located on an island several miles off the coast the swift motor boat carried your correspondent to the place of his call. Climbing up the rock shore I crossed the front lawn flanked by the beautiful white and black spruces which abound in this region. Along those woods I noticed some spacious perennial flower plantations, which, at a fleeting glance, showed all the evidences of good care. "Yes, flowers grow very well on this island," said the amiable lady of the house, when later, in the course of conversation I congratulated her on her cultural success; "but just look at the colors and how they insult each other." True enough, there was the orange red of tiger lilies alongside a clump of purple aconitums; the bright scarlet of phloxes lay in dispute with the blue shades of larkspurs; the rose pink of incarnilleas was fighting with the sulphur yellow of hemerocallis. "Color dissonances of this nature are unbearable to my eyes. Let us establish harmony where discord now rules. Will you please make a plan for rearrangement, taking proper regard for colors and have this plan carried out for me when planting time arrives?"

This was one of those examples, demonstrating the absolute necessity for the ornamental horticulturist and the modern landscape gardener desiring to cater to the needs of our refined classes to make himself acquainted with the principles of color harmony and train his vision as to agreeable contrasts and gradations of hues.

When associating varieties together, we naturally accentuate color and character of flowers of a given plant species. The results are singularly stronger effects. In the composition of herbaceous plantations of this nature we therefore should be careful not to join clashing shades, but should, to a certain degree, adhere to sim-



HYACINTHUS CANDIDUS

ilar laws the floral designer as artist is guided by. Thus, to the cultured eye the enjoyment of the beauty of flowers is heightened, for a pleasing harmony in the total effect intensifies it.

OPPORTUNITY FOR CULTURAL SKILL

There is not a single branch of ornamental horticulture offering more opportunities for an exhibition of individual artistic taste and talent and cultural skill than the herbaceous flower garden does today. Still how few of the vast number of gardeners realize this fact. It is true not everyone can have a fifty thousand dollar range of modern greenhouses at his disposal but it is equally true that in our days even a perennial border of moderate size can be made a means by which to show ambition and ability.

The generally keen interest of our wealthy and refined social classes in hardy herbaceous plants is nowhere more plainly seen than in our northern summer resorts. Here the high standard of plant material and the ever-changing brilliancy of floral outdoor displays are a source of generally unreserved admiration for them; an admiration, which is not seldom followed up by expressions of regret over the seeming impossibility to produce and enjoy the same rich displays on their distant suburban homegrounds. I fear it is not at last the perennial border as a labor saving scheme and the herbaceous flower garden as a side issue of second or third class order that deprives country home owners yet of the color brilliancy they here so frankly admire.

By all means the continuous study of hardy perennials is for the present and will be more so in the future an urgent necessity for every landscape gardener and care taker of home grounds. Their free use in all ornamental gardening is to be encouraged by all those desiring to take part in the progressive development of American horticulture.

Richard Rothe

We are sorry to announce that Mr. Rehder has been ill for the past two weeks. This explains the absence of his interesting Arboretum notes from our columns. We are in hopes that by next week he may be able to resume.

Narcissi and Daffodils

(Continued)

Daffodils proper, the large single-trumpet section of Narcissi, have within recent years held the center of the stage, and have been by far more popular here than their next-smaller cousins to whom we have referred in a former article; consequently a larger varietal number of this section is generally better known.

Yet notwithstanding the greater favor in which the large trumpet section has been held here, there still exists a remissness on our part in not introducing larger numbers of later superior kinds. When I recall, as a personal observer for over the space of twenty years and as an exhibitor and competitor for most of that time, our Massachusetts Horticultural Society shows, I cannot without misgivings compare our status in this specific field with that of our English cousins, seeing that during that long period of time the same kinds still continue to lift the "blue ribbon and cash" from the showboards; only three recent worthy new comers having been added during that time to the "Royal galaxy of Standbys" comprised of Emperor, Empress, Horsfieldii, Henry Irving, Double Von Sion, Princeps, Trumpet Major, Ard Righ, Dean Herbert, Maximus, Sir Watkins and a few others. Of the three added, Bicolor Victoria has been added for a number of years and a splendid variety it is: Madame de Graaf somewhat sparingly and, last but not least, comes Glory of Leyden, a massive and glorified Emperor in fact, with straw shading in the perianth.

While not minimizing the effectiveness and usefulness of double Von Sion for general decorative purposes, I cannot help regarding it as rather coarse and inelegant in a stand alongside the others mentioned; its doubleness has a pronounced discordant bearing when grouped with the large single-trumpet daffodil, and therefore it should be eliminated from this class in the show arena.

To whet the appetite of the yet lukewarm daffodil enthusiast and to stimulate a love for them, as well as to show our comparatively low status as general narcissi enthusiasts, is in a large measure the reason for writing this article. I will mention a few of the very finest varieties that are scarcely known as yet except through catalogue or magazine mention.

Weardale perfection, enormous size, known to measure five inches across, not many years ago worth two hundred and fifty dollars apiece, now somewhere about three dollars apiece; King Alfred, now eight dollars or less apiece, considered by many to be among the very finest; Duke of Bedford, four dollars or less each; Monarch, four dollars or less each, a grand massive variety and now famous as one of the parents of the finest white large trumpet-daffodils to date, Peter Barr, Madame de Graaf being the other parent. Pearl of Kent, another white from the same parentage but raised by the Rev. G. P. Hayden, the former having been raised by the firm from which it derives its name. These, however, are comparatively new and therefore very expensive, no less than one hundred and fifty dollars being asked for a single bulb in 1906. Pearl of Kent, is adjudged to be the equal in merit if not likely yet to eclipse Peter Barr. Cleopatra and a host of other fine varieties could be added to this list.

H. Furber

Soluble Fertilizers

AN APPEAL TO THE BUREAU OF PLANT INDUSTRY

Dr. Galloway has honored us with a communication in which he has reiterated his views as presented before the Carnation Society, but has not given us one iota of real information on soluble fertilizers. He says: * * * "fully as good results could be secured by the use of good composts alone as where chemical manures were applied." Just so, but he does not divulge any information for those ignoramuses who might like to try a few experiments under their own peculiar conditions. Is it not apparent that if chemical manures can do as well as composts then the chemicals may be advantageous to use for other reasons?

He says: * * * "florists are prone to overestimate the value of chemical manures, especially bone." * * * They certainly are, but the Doctor should be careful about calling Bone names or the manufacturers of the same will be after his scalp as their proudest claim is that there are no chemicals in theirs. Now, will not the Bureau of Plant Industry please tell the folks how to estimate chemical manures?

He says: * * * "it was extremely difficult to properly gauge the handling of these materials." * * * This we have knocked into us every few minutes, but as the Doctor has already concluded experiments where chemicals were used and has the data why not at least outline the danger zone in the use of these?

He says: * * * "if we were in position to always get good well-decomposed stable manure." * * * Yes, but how many growers are in this position?

Now let nobody mistake our attitude, we do not claim that soluble fertilizers are the whole thing. We are not optimists like Dr. Hensens. This gentleman, while on the roof of his office building, wholly absorbed in the Precession of the Equinoxes walked over the edge, and started down without aid of elevator. Being an optimist and wishing to allay the fears of his friends at the open windows he airily waved his hands at the various stories exclaiming, "All right, fellows, so far." Neither are we pessimistic. The Bureau of Plant Industry is too late now to shoo off this dangerous chemical business. Along with the approved use of chemicals in the field, does anyone think that the greenhouse man has overlooked all this? We hope no one reasons that the mere possibility of injury to stock will dissuade all brave investigators. It will not.

Consider Cyanide of Potash (or same thing, Potassium Cyanide). This is no candy for plants, nay, not even for human beings or dogs, but we ask in all seriousness, Has this entirely or even largely eclipsed its wide use as an insecticide? Proper chemicals are not harmful to life or property or even to plants, when *dilute enough*, and many are now using them. More want to and more must. Can not the Bureau of Plant Industry, having already the available data, publish a few pertinent facts as to experiments already performed with soluble fertilizers? Please! Dr. Galloway.

Rudley M. Bray

HORTICULTURE

VOL. VII

APRIL 25, 1908

NO. 17

PUBLISHED WEEKLY BY

HORTICULTURE PUBLISHING CO.

11 Hamilton Place, Boston, Mass.

Telephone, Oxford 292

WM. J. STEWART, Editor and Manager

SUBSCRIPTION PRICE

One Year, in advance, \$1.00; To Foreign Countries, 2.00; To Canada, \$1.50

ADVERTISING RATES

Per Inch, 30 inches to page \$1.00.
Discounts on Contracts for consecutive insertions, as follows:
One month (4 times) 5 per cent., three months (13 times) 10 per cent.,
six months (26 times) 20 per cent., one year (52 times) 30 per cent.
Page and half page spaces, special rates on application.

Entered as second-class matter December 8, 1904, at the Post Office at Boston, Mass under the Act of Congress of March 3, 1879.

CONTENTS

	Page
FRONTISPIECE—Early White Sweet Pea "Watchung."	
THE PRESENT IMPORTANCE OF HARDY PERENNIALS—Richard Rothe—Illustrated	557
NARCISSUS AND DAFFODILS—Kenneth Finlayson ..	559
SOLUBLE FERTILIZERS—Ludley M. Pray	559
OBITUARY—Edwin Hoyt—Franklin Pierce Davis— Robert T. Price—Joseph Quinn—Martha Blakeston Earl—Mrs. Albert Dirwanger—Theodore E. Horn	561
INFERIOR DUTCH BULBS	561
NEWS OF THE CLUBS AND SOCIETIES:	
European Society Doings	561
Gardeners' and Florists' Club of Boston—Pennsylvania Horticultural Society—New Orleans Horticultural Society—Newport Horticultural Society— Society of American Florists—Club and Society Notes	562
WINTER FLOWERING SWEET PEAS—Wm. Sim— Illustrated	563
MASSACHUSETTS AGRICULTURAL COLLEGE	565
SEED TRADE	566
EASTER PLANT NOTES:	
Gleanings from Chicago Plant Growers—Easter Plant Trade in Philadelphia	568
OF INTEREST TO RETAIL FLORISTS:	
Chicago, Detroit, Worcester—New Retail Flower Stores	570
EASTER FLOWER MARKET REPORTS:	
Detroit, Indianapolis, Philadelphia	571
Boston, Buffalo, Chicago, New York	573
Washington	581
MISCELLANEOUS:	
Business Changes	561
News Notes	561-564
Personal	562
Philadelphia Notes	564
List of Patents	566
Plant Imports	568
Incorporated	571
Greenhouses Building or Contemplated	580
Fire Record	580

foundation for the confidence of those who looked for a big, enthusiastic rally of old-fashioned Easter flower buying. On the whole, it would seem that we should be very grateful that the temporary interruption of full prosperity did not turn into a rout. It was a splendid demonstration of the courage of the common people—that great medium class to whom bonds and coupons are almost unknown—that they came to the rescue of the flower trade at a time when just this support was sorely needed and although disappointment is inevitable in some lines yet there is cause for congratulation that the outcome was so much better than there was good reason to expect it to be.

About
"lap seam"
boilers

Since the publication of the rules formulated by the Massachusetts Board of Boiler Rules wherein it appears that in all boilers installed after May 1, 1908, "the longitudinal joints of a boiler, the shell or drum of which exceeds 36 inches in diameter, shall be of butt and double strap construction," many florists have been under the impression that no lap seam boiler could be set, sold or made in Massachusetts after May 1 and have in some instances been worrying and hurrying to get boilers set before the day mentioned. A careful reading of the Act of 1907 relative to the operation and inspection of steam boilers, under which the state boiler committee works, convinces us, and our view is endorsed by the Hartford Steam Boiler Inspection and Insurance Co., that the rule in question applies *only to such boilers as are not exempt* under Chapter 465 of said Act. As a result of the agitation promoted by HORTICULTURE, aided and abetted by R. T. McGorum and other members of the Gardeners' and Florists' Club of Boston, at the time the Bill was under discussion by the State Legislature last year "*boilers used for horticultural purposes exclusively*" were exempted, in Section 1 of said Act, from inspection. Boilers exclusively for greenhouse use may, therefore, be constructed with lap or butt joints as may be preferred.

The early flowering
sweet pea

William Sim's endorsement of A. C. Zvolanek's claim to be the original producer of this valuable class of this popular flower, as expressed in his address before the Gardeners' and Florists' Club of Boston will carry gratification to many who have followed the arguments which have been going on from time to time as to where and how this winter-blooming section originated. We do not feel competent to have any decided views on this subject, our sympathies, however, being strongly on Mr. Zvolanek's side but Mr. Sim is in a position to speak with a conviction born of experience in a line in which he has few rivals and no equals in this country or possibly in the world. Moreover, Mr. Sim is a gentleman of unassuming character who would not think of taking so decided a stand in a matter of this kind without a full assurance that he was right and could maintain his position if assailed and his advocacy of Mr. Zvolanek's cause puts the latter gentleman in a place which, we think, will please all fair-minded people. With Mr. Zvolanek as the introducer and Mr. Sim as the great grower of these beautiful, free blooming-varieties the sweet pea is certainly well entrenched for the future. Its position "next to the violet" in popularity, as Mr. Sim modestly classifies it, may yet give the violet trouble. It is essentially a flower of the people with a fragrance equally pleasing and more lasting than that of the violet and a range of color excelled by no other flower. Evidently its career as an all-the-year-round favorite has only just begun.

Easter, 1908

The battle is over and it is our privilege to record that, from the accounts which have reached us, it appears to have been practically a "draw" between the forces of stability and demoralization. Very dubious, indeed, did the outlook seem for Easter, 1908. With the depression and inactivity generally prevalent in all lines of commercial enterprise and the curtailment of expenditures by the class of people whose free spending has been so strong a factor in the prosperity of the plant and flower business, it was not easy to find arguments to rebut the predictions of those who foretold disaster for the Easter business. It was equally difficult to see good

Obituary

Edwin Hoyt.

Mr. Edwin Hoyt of the firm of Stephen Hoyt's Sons Co. of New Canaan, Conn., died April 17, and was buried April 20. In the death of Mr. Hoyt, New England loses one of its oldest nurserymen. His age was 76 years. He died of pneumonia with other complications, having been taken ill on Sunday, the 12th day of April.

The nursery business of Stephen Hoyt's Sons Co. was started in 1849 by Stephen Hoyt, the father of the deceased. After Stephen Hoyt's demise, the business of this firm was carried on by his sons, James Hoyt and the deceased, under the firm name of Stephen Hoyt's Sons. In 1901, the business was incorporated under the name of Stephen Hoyt's Sons Co., of which Edwin Hoyt became president and manager, and remained so until the time of his death. He was uniformly courteous to the younger firms of nurserymen, to dealers in nursery stock and to all customers. Although at the ripe age of 76, he was as active in business and his intellect as clear as that of a man in the prime of life up to the time that he was forced to take to his bed.

He was a member of the Grange and of the Pomological Society of the State and was considered an authority on horticultural questions. In the nursery business to which he was strongly devoted, he was ambitious, energetic, far seeing, and a great worker. Under his management, the business grew to be one of the largest, if not the largest, nursery firm in New England, but with all his ambition, he was a just man and no mistakes were made in his business which he would not rectify if properly explained to him.

Mr. Hoyt was in 1888 a member of the State Legislature from New Canaan and a member of the State Board of Agriculture, Vice-President of the Board of Control of Connecticut Experiment Station and a member of the Connecticut Nurserymen Association, Chairman of the Board of Trustees in the First Congregational Church of New Canaan and a member of the Board of Deacons at the time of his death, and otherwise actively interested in the town in which he lived. He was President of the First National Bank of New Canaan, and had large property interests which will probably inventory from \$300,000 to \$400,000. He is survived by his brother James, a widow, three daughters, and one son. He was very devoted to his family. The funeral was held at his residence and was largely attended by people from different parts of the State and from New York as well as by his neighbors and friends. The sad and sacred duty of bearing the remains to the grave was performed by his foreman, Edward Kelley, and his brothers, Frank, James and Harry Kelley, all assistant foremen in the nursery for many years.

So ends the career on this earth of one of our best known Christian business men.

Franklin Pierce Davis.

F. P. Davis, a prominent florist of

Summerville, Ala., died suddenly on April 6. Col. Davis was born in Mobile on June 18, 1852, was manager of the Mobile Compress Co. for thirty years, until he started in the nursery and florist business some five years ago. He quickly built up an extensive business, his establishment being one of the largest in the South. He was a member of the Society of American Florists and held the position of State vice-president this year. Col. Davis was twice married, and a widow and seven children survive him.

Martha Blakeston Earl.

At Bryn Mawr, Pa., on April 16th, aged 66. Mrs. Earl was the widow of the late George W. Earl, a prominent Philadelphia business man, who was long well known as a keen amateur horticulturist. One of her sons, Howard M. Earl, is manager for W. Atlee Burpee & Co.

Robert T. Price.

R. T. Price, Lawrence, Mass., died on April 15 in his eighty-first year. Mr. Price was a native of Wales and was for many years a prominent florist in the city, but retired some time ago from active business.

Joseph Quinn.

Joseph Quinn, landscape gardener, died at East Ryegate, Vt., on April 12, at the advanced age of 111 years. He was born in County Cork, Ireland, and came to this country in 1817.

Mrs. Albert Dirwanger.

We regret to learn of the death, four weeks ago, of the wife of Albert Dirwanger of Portland, Me. Besides her husband she leaves one son and one daughter to mourn her loss.

Theodore E. Horn.

Theodore E., son of Anna W. and Julius Horn, died at Arlington Heights, Mass., on April 11, at the age of 22.

BUSINESS CHANGES.

Frank J. Prouty has leased I. W. Bigelow's greenhouse, Spencer, Mass.

M. B. Kingman, Amherst, Mass., has moved his florist store from Amity street to Hunt's block.

Mrs. G. C. Sanborn of Lakeport, N. H., has leased the Gilman greenhouse, and will devote it to early vegetables.

J. F. Ammann has purchased the business of Mrs. Albert Dietschy, Alton, Ill., and will retain Mrs. Dietschy as manager.

G. S. Crego of Maywood, Ill., has removed to Portland, Ore., where he will continue in the aster seed business that he has so successfully established.

The American Evergreen Company succeed the A. J. Fellouris Co., at 52 West 28th Street, New York. They will shortly remove to 103 West 28th Street.

NEWS NOTES.

Henry Riler of Torrington, Conn., opened his greenhouse just previous to Easter for retail business.

G. Fleischer, Pueblo, Colo., has recently completed additions to his range of houses, heating and ventilating apparatus, at a cost of \$15,000, making his plant one of the largest and best equipped in that section.

EUROPEAN SOCIETY DOINGS.

Ghent Quinquennial Show.

This great Belgian horticultural show held by the Royal Agricultural and Botanical Society of Ghent promises to be one of the most important events in the gardening world during the present year. The show coincides with the one hundredth anniversary of the foundation of the Society and every effort is being made to celebrate the occasion with becoming importance. The schedule comprises 760 classes and is a publication of 118 pages giving full details of prizes, etc., to be awarded. The show will be opened by the King of the Belgians on April 28 and close on May 3.

The international jury consists of 247 members who will represent Germany, England, Belgium, Brazil, Denmark, Egypt, Spain, France, Holland, Italy, Duchy of Luxembourg, Russia, Sweden, Switzerland. P. J. Berkman and Julius Roehrs have been invited to represent the United States.

A list of the festivities appears in a recent issue of the "Tribune Horticole" (March 21). Those who have experienced Belgian hospitality will have no need to be reminded of the generous and lavish manner in which it is bestowed upon the foreign guests on such occasions.

Paris Spring Show.

The annual spring show of the National Horticultural Society of France will be held in the greenhouses of the Cours la Reine, Paris, on May 22 to 29. A horticultural conference will also be held at the same time. There is a good schedule, varied in extent, affording ample justification for expecting a fine display. American visitors to the gay capital at that time should not miss so important a sight.

INFERIOR DUTCH BULBS.

Editor HORTICULTURE:

Dear Sir:—We beg to say that we heartily endorse the sentiments expressed in your editorial in issue of April 18, believing that same is a step in the right direction, fully convinced that the foreign bulb sellers have made America a dumping ground for their inferior bulbs, thereby causing growers to suffer considerably by such inferior bulbs producing blooms of little value, and believe the time is now ripe when growers should dictate to these Holland bulb houses that they must deliver the growers the right kind of bulbs, otherwise if they cannot deliver the goods that the growers should then get together and refuse to give orders to such houses that are supplying this country with a poor quality of bulbs.

Hoping that the growers throughout America will stand firm in matters pertaining to the above, we beg to remain,

Yours very truly,

J. A. BUDLONG.

Chicago, Ill.

President Roosevelt has directed that a memorial oak be sent to East Haven, Conn., and planted on the site of Gen. Lafayette's camp, which was occupied during the war with Great Britain. The oak will be planted on Arbor day.

NEWS OF THE CLUBS AND SOCIETIES.

GARDENERS' AND FLORISTS'
CLUB OF BOSTON.

The announcement that William Sim would address the club on the topic of Sweet Peas Under Glass served to attract a very large attendance of interested members to the meeting at Horticultural Hall, Boston, on the evening of April 21. The hall was fragrant with the odor of lilies and sweet peas which had been contributed for exhibition. Mr. Sim's paper, which we are pleased to be able to publish in part in this issue, was intently listened to and after its conclusion an interesting discussion ensued. Replying to questions, Mr. Sim said that it was his custom to apply bone meal or sheep manure to the beds two or three times after the peas have begun to flower. In connection with his plan of using the same soil for years in succession, he said that on the completion of the crop he does not pull out the plants, but cuts them down, leaving the roots in the soil. He reiterated his belief that planting peas in a trench and drawing the soil about the stems after the plants begin to grow is not advisable for indoor culture, and saw also some objections to this process in outdoor culture. For the latter his advice would be early sowing and using not over a pound of seed for a 300-foot row.

The principal attraction of the exhibition table was a display of about thirty seedling lilies in bloom—hybrids between longiflorum and Philippinense. James Farquhar gave an account of same, stating that cross fertilization had been done in June, 1906, seed sown February 17, 1907, and on Dec. 17, ten months later, the first flower had bloomed. The plant on which this flower had appeared was in the group exhibited and had two new growths, very strong, on which buds were in evidence; and in a number of the blooming plants shown, second growths were already well along, showing that the peculiar herbaceous character of the Philippine lily, with its disposition to continuous growth and blooming, is well established in the offspring, while the robust growth and luxuriant foliage of the longiflorum are also well perpetuated.

William Sim showed a dozen vases of the finest of the winter flowering sweet peas. A hybrid caecolaria, which has been named Stewartii, was shown by George Stewart. Its seed parent was the rugosa Golden Gem and a flower of one of James' strain of the common C. hybrida furnished the pollen. Other exhibits were Liliun candidum and larkspurs from W. N. Craig, mushrooms and Gerbera Jamesoni from Thomas Cotes, Marechal Niel and Chatenay roses from Mr. Page of Newton Highlands.

Members of the landscape gardening class had the result of their winter's work on exhibition in the form of plans and sketches for laying out and planting home grounds, which were a centre of prime attraction.

PENNSYLVANIA HORTICULTURAL
SOCIETY.

Prof. Stevenson Brown gave a talk on weeds illustrated with stereopti-

con, which was well received and proved interesting and instructive. A sport of Cattleya Schroederæ was exhibited by A. Pericat, and was awarded a certificate of merit. This is a highly colored Schroederæ—pink with purple lip. A similar sport appeared about three months ago, and Messrs. Sander's representative thought so well of it that he secured it for his firm. A certificate of merit was also given to William Kleinheinz for Cypripedium Curtisii newbillo. Arrangements were made for the Peony show, end of May or beginning of June—date to be announced later. The June Rose and Sweet Pea show is also under the care of the committee, with power to split dates if season compels. On account of business exigencies in the hall management, the dates of the Fall and Spring shows had to be fixed at this meeting. These will occur Nov. 10 and March 22 prox.

NEW ORLEANS HORTICULTURAL
SOCIETY.

The regular meeting of the above society was held April 19. The chrysanthemum show committee reported that the premium list would be distributed by the end of the week. Several prizes which it is hoped the public school children will compete for have been offered.

E. Baker, late in charge of the gardens in Audubon Park, who has been a member of this society for many years, sent in his resignation. He is going out of the flower business, and entering commercial life. By unanimous vote, he was elected an honorary member.

A communication was received from J. A. Newsham, now in British Honduras, stating that he had been on a still hunt for orchids, and had secured forty-three snakes, which were obtained after nine days' journey on mule-back, and that the load was carried to the seashore on the backs of fourteen mules.

A. Alost invited the members to call at his place on Gentilly Road on May 3, and enjoy the annual dinner which he tenders the Horticultural Society. It is proposed to invite Mayor Behrman and Congressman Broussard. Transportation will be furnished to the society by the Steckler Seed Co., and if there are not enough conveyances, Herman Doescher has offered all vehicles that may be needed.

The secretary reported that J. Verburgh had lost his son, age seven years, who was crushed by an electric car. The sympathy of the society was extended to him.

CHAS. R. PANTER, Secretary.

NEWPORT HORTICULTURAL
SOCIETY.

This society will hold its annual Rose and Strawberry Show on June 22 and 24, 1908. Anyone wishing premium list and entry blank may have same by applying to the secretary.

DANIEL J. COUGHLIN, Secretary.

SOCIETY OF AMERICAN FLORISTS
AND ORNAMENTAL HOR-
TICULTURISTS.

The Frank Cummings Bulb & Plant Co., of Meridian, Miss., apply for registration of a canna as follows:

Canna W. E. Cottrell, seedling of L. Patry, originated with us. Flower large dark salmon pink slightly flecked with red, petals large rounding, slightly recurved, large branching flower heads, very broad leaves slightly edged with bronze, thick and leathery, growth very vigorous, height 4 feet.

Public notice is hereby given of this application for registration and any persons objecting to the same or knowing of any reason why the registration should not be made as above, are requested to forward a statement of their objections to the undersigned at once.

No objection being received within twenty days from this date, the registry will be completed.

W. N. RUDD, Secretary.

April 27th, 1908.

CLUB AND SOCIETY NOTES.

The Minnesota State Horticultural Society, organized in 1866, has a membership of 2,430. As may be imagined, it is a real live society and is doing good work.

The Civic League, Beaufort, S. C., held its annual flower show on April 7. Every available space was filled with the exhibits, among which roses predominated, although many rare plants were contributed, all from private sources, as Beaufort has no commercial florist.

PERSONAL.

Patrick Burke has been reappointed forest warden of Clinton, Mass.

A. Marine of Chicago has taken a position with the Park Floral Co., Denver, Colo.

The wedding of A. E. Wohlert of Merion, Pa., to Elizabeth Olmes Crippen was celebrated on Monday, the 20th inst.

Mrs. Thomas Young, mother of Secretary John Young of the New York Florists' Club, is critically ill at her home in Passaic, N. J. Mrs. Young is 81 years of age.

Roy D. Underwood, secretary of the Jewell Nursery Co., Lake City, Minn., has just been elected mayor of that city. When he assumes his office he will be the youngest citizen ever elected to this position.

W. R. Smith has been quite ill for some time at his home in the Botanic Garden, Washington, and is not yet able to leave his room. A bad cold brought about a return of his old heart trouble and the necessity for absolute quiet has made it impossible for him to receive visitors.

WINTER-FLOWERING SWEET PEAS.

(Read before the Gardeners' and Florists' Club of Boston by Wm. Sim.)

The sweet pea is one of the staples in cut flowers, ranking in this respect next to the violet. I will not go into the ancient history of the sweet pea, but confine my remarks as much as possible to the winter or early flowering section, the advent of which I think is within the memory of the youngest member here. It is only within the past ten or twelve years that the sweet pea has been placed before the people in the winter months. By growing the old varieties under glass it was only possible to have them at the most five months of the year. With the advent of the early flowering section it was made possible to cut flowers all the year. The first sweet peas I grew under glass were such varieties as Blanche Ferry, Emily Henderson, Katherine Tracy, Countess of Radnor and Emily Eckford. These are of the late or summer flowering section. These varieties when sown under glass

January, 1892, he found some of the plants producing flowers which were small in size, and the plants only attained the height of two feet, but by crossing and re-crossing a strain producing large flowers on long stems, and growing six feet in height, was secured. At this time Mr. Zvolanek was not in business for himself, and raised them mainly for pleasure, and gave seed to any of his friends who wanted some. While in the employment of Mr. Thomas Young of New York in 1895-6 he had two houses of Christmas Pink. If this story is correct it shows that he must have had them about the time he states in order to get seed enough to plant two houses in 1895. This was three years before it was put into commerce by Burpee.

The origin is also claimed by Thomas Gould of Ventura, California. This is the variety sent out by Burpee as "Earliest of All" in 1898. If I am right, I think this strain of Mr. Gould's was first seen in bloom among plants of Blanche Ferry. In 1898 Mr. Zvolanek started with Emil Leuly of West Ho-



EARLY FLOWERING SWEET PEA, MRS. GEO. W. LEWIS
At Wm. Sim's, Cliftondale, Mass.

in August would not come into bloom until the end of the following April, and seed sown in January would flower as early as that sown in August. They have a season of flowering and will not flower before that time, no matter when the seed is sown. The early-flowering sweet peas are just the opposite in this respect, for in many cases they commence to flower when only a few inches above the soil, and if sown in July they will flower in August. They make a very poor growth in summer and do not do so well as the late varieties. In the winter months, however, they make a very strong growth, and while making this growth they bloom.

Origin.

The origin of the winter-flowering sweet pea is something that seems to be a mystery. A. C. Zvolanek of Bound Brook, New Jersey, is one of several who claim to have been the originator. He claims that he made his first experiments twenty-five years ago, but did not succeed until he made a cross with the European vetch. In

Hoboken and had at that time six houses of Christmas Pink and Florence Denzer. Now there is no difference between this Florence Denzer and Mont Blanc. They are the same in every respect. Benay of Erfurt, Germany, sent out Mont Blanc I think in 1902, or four years after Mr. Zvolanek was-raising it in Hoboken. If Mr. Zvolanek would again cross with the vetch the old varieties, and secure an early-flowering strain, his claim would be substantiated. He has promised to do this.

Sports.

Many claim that the varieties of this strain are habit sports; that they produce flowers identical to the late varieties from which they sported. I do not believe they do sport myself, for I have grown a great many both inside and outside, and have never had one sport with me. Mr. Zvolanek, who has raised practically all the winter-flowering varieties, says he has never had one sport with him. Mr. Zvolanek raised Christmas Captain as a result of a cross between Captain of the Blues and Christmas Pink. A grower in

**FLOWERING PLANTS
BEDDING PLANTS
CHOICE SHRUBBERY
SUMMER BULBS
BEST EVER OFFERED**

W. ELLIOTT & SONS
201 Fulton St., New York

TOWER HOTEL
Niagara Falls, N. Y.

is soliciting your patronage during the S. A. F. Convention.

Very truly yours,

M. J. HOENIG, Prop.

England claims Captain of the Blues sported with him from the late to the early type, but I believe this was only a stray seed of Christmas Captain which had in some way gotten among his Captain of the Blues, for he was growing seed of Mr. Zvolanek's at the time. I think the cause is apparent. It is also possible that if he were growing the two types side by side cross fertilization may have taken place, and the early flowering one may have been the result. It is claimed by some that sweet peas do not mix, but the more I grow of them the more convinced I am that they do mix more or less. There is not one variety I grow but what quite frequently exposes its pollen and pistil, so in this case what is there to prevent insects or flies from carrying the pollen? Some claim these are detormed flowers and would not go to seed anyhow, but this is not the case, for if they are left on the plants they go to seed every time and produce fine seed. I am told this is far more marked on the seed farms in California than in a greenhouse. I believe the early sweet is the result of a cross between the old type and some other species. I do not believe the late sweet pea can sport from the late to the early flowering, and will only believe so when I have conclusive proof that this is the case. Many growers on seeing some variety they imagined they sowed, without examination immediately call it a sport. They do not stop to consider that there are many ways for that seed to get there. The seedsman and seed grower cannot always prevent the seed getting mixed.

(To be Continued)

PHILADELPHIA NOTES.

David Rust, receiver of the William Graham Co., reports a fortunate deal on their left-over Easter lilies. Some two thousand pots with two to four flowers each were sold at ten cents a flower as souvenirs to the matinees of "The Time, the Place, and the Girl," running this week at the Walnut Street Theatre.

Edwin Lonsdale has accepted the office of correspondent for the "Florists' Exchange" in this locality. P. M. Read will look after the business end. Mr. Read, we understand, is an advertising agent with two or three other papers on his list, the principal one being a publication entitled "Novelties" (not horticultural novelties).

Chas. P. Poryzeas says concerning the Easter trade: "Cut flowers fine-plant trade very disappointing." As the days go by after Easter we hear more of left-over plant stock, confirming our judgment in our Easter plant review, which was written earlier and under difficulties. The special difficulty was refusal of those interested to give up information. We regret as much as anybody the unfortunate conditions; but we are here to report facts and not fairy tales. As a sample of the readiness of the trade to commit itself to definite statements, here is the Delphic utterance of Leo Nielsen: "Well! we were very busy. We are still getting enough to eat, and we can still pay our bills! How do you suppose a correspondent could write a market review on the hole of a doughnut?" The trouble with many is that they look on those serious things like market reviews as a joke—the same as Joe Cannon does with the Democrats when they call for the yeas and nays."

NEWS NOTES.

Shirley & Fowle, Danvers, Mass., opened their greenhouses to the public during Easter week, with an unusually attractive display.

Thaddeus N. Yates & Co. report nursery business very brisk and much better than expected. They are just commencing the shipment of a large order of trees for the Massachusetts Highway Commission.

AMERICAN NURSERY CO., COMBIN-
ING
FRED'K W. KELSEY, New York City
F. & F. NURSERIES, Springfield, N. J.
BLOODGOOD NURSERIES, Flushing, L. I.
N. J. & L. I. NURSERIES
We can supply your every need. Write for prices
Sales Department
150 BROADWAY, - NEW YORK

ROBERT CRAIG CO.
ROSES, PALMS,
and Novelties in Decorative Plants
MARKET and 49th STREETS., PHILADELPHIA, PA.

DAHLIAS. Now is the time to place your order for bulbs which will insure you getting named varieties in any quantity; prompt delivery.

DAVID HERBERT & SON,
Successors to L. K. Peacock, Inc.
ATCO, N. J.

The F. E. Conine Nursery Co.
STRATFORD, CONN.

If you are particular and desire fine Nursery Stock, true to name, send your order to us. It is early, we will ship for two or three weeks yet.

**RHODODENDRONS, ANDROMEDAS, KALMIAS
AND SPECIMEN EVERGREENS**

JOHN WATERER & SONS, LD.
AMERICAN NURSERY

BAGSHOT, - - - ENGLAND

LIVE FENCES

We believe we are the largest growers of Hedge plants in America—Privet our specialty—can supply any quantity both

Amoor River and California, strong plants, at \$25.00 per M. Other varieties. Prices on application.
PETER'S NURSERY COMPANY, - Knoxville, Tenn.

RHODODENDRONS

Hardy Hybrids - 1½ ft., 2 ft., 3 ft., 4 ft., 5 ft.

Box - All sizes Bush, Pyramid and Standard.

Roses - Large assortment, Hybrid and Climbing.

Herbaceous Perennials, 1000 varieties

Send for General Catalog and Trade List

The NEW ENGLAND NURSERIES, Inc.
BEDFORD, MASS.

The MORRIS NURSERY CO.
West Chester, PA.
NURSERIES ESTABLISHED 1849
SPECIALTIES for SPRING 1908
Norway Maple, 2 2½ in. dia. and 2½-3 in. dia.
Carolina Poplars, 10-12 ft., 1½-2 in.
Cal. Privet Hedge Plants 2 yrs. old 2-3 ft. and 3 and 4 yrs. old 3-5 ft. Dwarf Box, 3-6 in.
Rhododendron Hybrids, 18-24 in. and 2-3 ft. choice hardy varieties. Rhododendron Maximum, 2-8 ft., fine plants in car lots.
Kalmia Latifolia 1-4 ft., fine plants in car lots.
Blue Spruce, Koster's, 3-5 ft.
Hybrid Roses, choice varieties.
Catalogue mailed upon request. Address all communications to
The MORRIS NURSERY CO
Sales office, 1 MADISON AVE., NEW YORK

Hardy Rhododendrons, Azaleas Conifers, Clematis, H. P. Roses, Shrubs and Herbaceous Plants from our
HOLLAND NURSERIES
Prices Moderate
P. OUWERKERK, 246 Jane St., Weehawken Heights P. O. No. 1, Hoboken, N. J.

**Single Chrysanthemums
ARE THE CRAZE**

for the time being.

Are you in line to meet the demand?

I have now ready
**KATIE COVELL, ROB ROY,
HELEN TOTT, HAROLD
BISHOP, MRS. UNTER-
MEYER, ANNA
SPANGLE.**

and others, at
\$2.00 per doz., \$15.00 per 100.

I also carry a full line of novelties and standard varieties of

Chrysanthemums, Carnations and Roses

CHAS. H. TOTT, MADISON, N. J.

Established 40 Years
Rose Hill Nurseries
New and Rare Plants
NEW ROCHELLE, N. Y.

New York Office, Siebrecht Building, 425 Fifth Avenue

100,000 DAHLIAS

Premium Stock, guaranteed true to name. 500,000 large Flowering Gladioli, hundreds of colors and variations mixed Wholesale prices on application. Order now for spring delivery. Catalogue free.

J. L. MOORE, Northboro, Mass.

NOTES FROM THE MASSACHUSETTS AGRICULTURAL COLLEGE.

A Carnation Show.

The department of floriculture have arranged for a carnation and rose exhibit in Wilder Hall Friday evening, April 24, and Saturday, April 25. It is felt that the students at the college should receive a better training in varieties of commercial crops than they can get from materials now grown in the vicinity. The students feel that they cannot afford to travel for this study, therefore this exhibit has been arranged. Professor E. A. White has written many of the most prominent rose and carnation growers, asking if they would send one or two dozen blooms of their standard varieties for exhibition at this time, and has received many cordial replies.

Proposed New Greenhouses.

The trustees of the college are asking for a legislative appropriation of \$34,000 for a new range of greenhouses of modern commercial type, with an attached teaching building for use of the floricultural department. It is not the intention of the college to engage in commercial floriculture, but a new range, adapted to giving the students up-to-date instruction in methods of growing cut flowers for the trade, is badly needed. It is expected to build an instruction building costing about \$15,000. This will contain a large laboratory and work room to accommodate at least fifty men at one time, a class room for one hundred men, smaller class rooms, office and a room for the exhibition of material used in greenhouse construction. The basement will contain a soil and fertilizer room, a cool room for bulbs and rooms for storage of pots and implements.

The greenhouse range as now planned will consist of a palm house 30x40 ft. on the east end of the general work-room. From the south side of this work-room a house 12 feet wide and about 180 feet long will run directly south. This will be used for propagation and for general plants. On the east and west sides of this low, narrow house the special houses of the range will be built. This will provide for a full southern exposure for each house. The range as planned includes a students' house for special student work, 30x50 ft.; violet house, 24x50 ft.; chrysanthemum and bedding-plant house, 24x50 ft.; lettuce house, 24x50 ft.; rose house 24x50 ft., a carnation house, cucumber house and tomato house, each of the same dimensions.

SURPLUS

Peas and Beans at attractive prices to close out surplus.
 40 bu. Peas, First and Best at \$2.25
 5 " " Alaska " 4.00
 20 " " Gradus " 4.50
 5 " " Nott's Excelstor " 3.00
 5 " " Premium Gem " 3.00
 15 " Beans, Carrie's Rust Proof " 2.50
 15 " " Improved Golden Wax " 2.50
 15 " " Burpee's stringless Green Pod " 2.50
 12 " " Red Valentine " 2.25
 8 " " Refugee " 2.25
 8 " " Wardwell's Kidney Wax " 2.50
 7 " " Mohawk " 2.25
 20 " " Dreyer's Bush Lima " 5.00
 Gladioli Bulbs, large No. 1, fine mixture, at \$4.00 per 1000.
 Cauliflower plants, Early Dwarf Eriart, nice stock, hardened ready for planting, at \$1.00 per 1000.
 Cabbage plants, Early Jersey Wakefield, Early Summer and Large Charleston Wakefield, 4 in. c. plants, hardened ready for planting, at \$2 per 1000. \$15 per 10,000.
 Egg plants, Black Beauty and New York Improved Spineless, at \$1.00 per 100.
 Strawberry plants, quality collection, 300 plants in five varieties early to late, for \$2.00. All above quick cash offer. Mention this paper. Address
W. F. ALLEN, 102 Market Street, Salisbury, Md.

HARDY PERENNIALS

Strong plants in fine condition for immediate effect. All fresh and thrifty.

- | | |
|--|--|
| <p>Aquilegia Cerulea and Chrysantha
 Asclepias Tuberosa
 Bocconia Cordata
 Boltonia Asteroids, \$4.00 per 100.
 Campanula Carpatica Persicifolia and Pyramidalis, blue and white.
 Delphinium Formosum, Elatum Hybridum and Coelestinum
 Dianthus Barbatus, \$4.00 per 100
 Di tannus Fraxinella Rubra
 Digitalis Gloxiniiflora, White and Rose
 Erianthus Ravennae
 Eulalia Gracilis Urivatata
 Eupatorium Coelestinum
 Gypsophila Paniculata at \$6.00 per 100
 Heliathanus Maximilliana</p> | <p>Helianthus Toltis Grandiflora
 Heliopsis Pitcheriana
 Hybi cus Crimson Eye, \$3.00 per 100
 Oenothera Frazeri, \$6.00 per 100
 Poppy Oriental, Bracteata and Nudicaule
 Pentstemon Barbatus, Torreyii
 Platycodon Grandiflorum and Mariesi, \$4.00 per 100
 Physostegia Virginica
 Plumbago Larpente
 Rudbeckia, Golden Glow, \$3.00 per 100
 Rudbeckia Purpurea
 Salvia Azurea Grandiflora, \$6.00 per 100
 Stokesia Cyanea
 Tritoma Uvaria Grandiflora, \$4.00 per 100
 Tritoma Pfitzeri, \$7.00 per 100, \$60.00 per 1000
 Yucca Filamentosa, \$8.00 per 100</p> |
|--|--|

Unless noted, \$5.00 per 100. (For complete list see catalog No. 5.)

THE STORRS & HARRISON CO., PAINESVILLE, OHIO

The Leading Horticultural Paper on the Continent
LA TRIBUNE HORTICOLE

PUBLISHED WEEKLY

Official Publication of the Royal Lionean and Flora Societies of Brussels and the National Commission of Pomology of Belgium. Ordered by the Board of Education for the Schools and Scientific Institutions, by the Board of Agriculture and the Board of Justice.

Well Written Up-to-Date Splendidly Illustrated

LA TRIBUNE HORTICOLE gives Cultural information, also all the Gardening News and Full Reports of the Horticultural Meetings and Shows held on the Continent.

12 Water Colored Plates & 40 Half Tone Supplements in each volume

It is the CHEAPEST and best Gardening Paper in Belgium, forming each year a splendid volume of 832 pages of text and 52 SUPPLEMENTARY ILLUSTRATIONS.

LA TRIBUNE HORTICOLE has the Largest Circulation on the Continent, and is the best medium for advertising.

Annual Subscription 8/-, Post Free.

Specimen Copy Post Free on application.

Offices - - - **43, RUE VONCK, BRUSSELS**

500,000 Palmetto Asparagus Roots
 2, 3 and 4 Years Old.

Well developed. Grown on Bloomsdale.
 Trade Price, - \$3.50 Per Thousand.

No Order will be taken under One Thousand

D. LANDRETH SEED COMPANY, - - Bristol, Pa.
 Bloomsdale Seed Farms.



Anything of Value
 to the profession
CAN BE SOLD
 through advertising in
Horticulture

Seed Trade

Interest is now centered in the Mann Pure Seed bill, and the efforts of seedsmen to trim that measure into some shape that will not imperil nor outrage their rights are being watched with keen interest not unmixed with anxiety by the trade in general. An influential body of seedsmen had a hearing at Washington before the House Committee in charge of the bill, on the 21st, and it is pleasing to note that their efforts were not fruitless.

The past week as a whole has not furnished the sort of weather to boom the retail seed business, yet there has been little diminution in activity, with a very few exceptions, but the March-like weather of the early part of this week was well calculated to make people think of furs and furnace fires instead of gardening, yet if they would only recall the promise that "Seedtime and harvest shall not fail," they would order their seeds, bulbs, etc., and have them in readiness for the day when warmth and sunshine shall again give promise of the harvest. As to plants it is not surprising that people should not buy these until the moment arrives for putting them out into the ground. For the quality of its weather, April of this year shows but little improvement over its namesake of a year ago, but let us hope May has something more cheering for all.

The next Canners' Convention will not be held at Chicago, according to what seems to be reliable information just to hand. For several weeks this matter has been in the air, but now appears to be settled. It seems that the Chicago representative who at the Cincinnati Convention took the Canners up into a mountain and showed or promised them, not exactly kingdoms, but many alluring things which would cost them nothing, was indulging in super-heated air of the Chicago brand.

The Canners, to whom the promise of something for nothing appeals with quite irresistible force, eagerly accepted the proposals of the "Windy City" man, but in the light of investigation the whole affair appears as a money-making scheme, for which the Machinery and Supply Men's Association were expected to furnish the sinews of war. Space for their use was to be sold by the square foot at prohibition prices, and other conditions imposed which could not be patiently considered. It is also said that, in this beautiful scheme, only one member or employe of a firm was to be

furnished with a pass, others being compelled to pay each time they entered, and when it is recalled that some exhibitors have ten to fifteen men, it can be readily seen what this would mean. As to the Canners, it is said that the officers were to receive passes but the rank and file were to pay.

It is evident that whoever hatched this scheme was under the impression that only the Canners were to be considered, and that wherever they decided to go, the Machinery and Supply Men would feel compelled to acquiesce, hence the nicely-laid plan to make them pay the toll, but the schemers reckoned without their host, and no modification of their plans nor any overtures from them will receive serious consideration now.

Two places are prominently mentioned as likely to be chosen—Louisville and Atlantic City. A third—Denver, receives some consideration, but a possible dark horse about which little is said just now, but which may after all carry off the prize, is Rochester. Don't overlook Rochester, N. Y.

The catalogue register is the seedsmen's best general asset. Its loss would mean practically beginning business all over again. A. T. Boddington had this in mind when he installed a new six-ton safe in his store at 342 W. 14th street, New York, last week.

As we go to press we have news from Washington that the Mann Seed Bill has been laid aside for this session of Congress and perhaps for ever.

W. Atlee Burpee and family of Philadelphia sailed for Europe on the S.S. Adriatic April 22nd.

D. I. Bushnell of St. Louis sails from New York this week on a short European trip.

LIST OF PATENTS.

- 882,748. Mowing Machine. Charles W. Robinson, Hamilton, Ontario, Canada.
- 882,796. Hand Fertilizer Dropper. John T. Flippen, Greystone, Va.
- 884,113. Plow. Harry W. Via, South Boston, Va.
- 884,164. Plow. Mark C. Jordan, Ellisville, Miss.
- 884,208. Greenhouse Construction. Joseph H. Rice, Ashtabula, Ohio.
- 884,258. Weed Cutter and Cultivator. Frank Baker, Sparta, Ky.
- 884,319. Insect Destroyer. George W. Darnell, near Edna, Tex.



Boddington's

Matchless Giant Primulas

PRIMULA SINENSIS

Boddington's Matchless Giant Primulas Mixed. This selection includes all my finest Giant Single Primulas of the plain-leaved class. ½ pkt. 60 cts., pkt. \$1.

Boddington's Matchless Giant Pure White.

Boddington's Matchless Giant Blush-White.

Boddington's Matchless Giant Orange King. A delightful novelty; almost orange.

Boddington's Matchless Giant Rose.

Boddington's Matchless Giant Scarlet.

Boddington's Matchless Giant Royal Blue.

Each, ½ pkt. 60 cts., pkt. \$1. Collection of above 6 varieties, ½ pkt. each, for \$3.50

Boddington's Double Blue. A double form of our matchless blue.

Boddington's Double Pink.

Boddington's Double Scarlet. A most striking color.

Boddington's Double Crimson.

Boddington's Double White.

Boddington's Double Mixed.

Each, ½ pkt. 60 cts., pkt. \$1. Collection of above 5 varieties, ½ pkt. each, for \$3.

BODDINGTON'S STAR PRIMULA

(*Primula stellata*)

We offer a greatly improved strain of these new and free-flowering Primulas, saved from named varieties only. They make excellent pot plants for decorative purposes.

Boddington's Giant White Star. Pure white.

Boddington's Giant Purple Star. Rosy purple.

Boddington's Giant Red Star. Intense carmine-red.

Boddington's Giant Blue Star. Heavenly blue.

Boddington's Giant Pink Star. Soft pink.

Boddington's Giant Salmon Star. Deep salmon.

Boddington's Star Choicest Mixture.

Each of above, ½ pkt. 60 cts., pkt. \$1. Collection of above 6 varieties, ½ pkt. each, for \$3.

Boddington's Giant Double Crimson Star. Very fine double form of the Stellata type. ½ pkt. 60 cts., pkt. \$1.

PRIMULA OBCONICA GIGANTEA

Primula obconica gigantea Kermesina. Beautiful deep crimson.

Primula obconica gigantea alba. The pure white flowers greatly enhance the beauty of the existing lilac, rose and crimson shades.

Primula obconica gigantea lilacina. Beautiful lilac.

Primula obconica gigantea rosea. Lovely rose.

Primula obconica gigantea grandiflora. Mixed varieties, containing pure white to deep crimson.

Each of above, ½ pkt. 30 cts., pkt. 50 cts.

PRIMULA floribunda grandiflora. Buttercup. Small yellow flowers, borne in great profusion, fine for pots. Pkt. 50 cts.

Forbesi (Baby Primrose). Pkt. 25 cts.

PRIMULA KEWENSIS

(*Giant Buttercup*)

This plant is a strong grower, with bright green leaves and numerous erect flower-scapes 10 to 18 inches in height, producing flowers in whorls at intervals along their whole length. The flowers are fragrant, bright yellow in color, with a slender tube and spreading limb nearly an inch in diameter. As a winter flowering decorative plant it is an acquisition; very floriferous when in a small state. ½ trade pkt. 50 cts., pkt. \$1.

ARTHUR T. BODDINGTON,

342 West 14th St.
NEW YORK, N. Y.

SPRING FLOWERING BULBS

HARDY JAPANESE LILIES

	Per Doz.	Per 100	Per 1000
Lil. Auratum (Golden Banded Lily) 8-10 in.	\$ 75	\$5.00	\$45.00
Lil. Tigrinum, (Koch's) 8-10 in.	1.00	7.00	65.00
Lil. Telpomene, (Tremson) 8-10 in.	1.00	7.75	65.00
Lil. Rubrum or Roseum, 8-10 in.	1.75	14.00	\$75.00
Lil. Tigrinum Splendens, (Single Tiger Lily)	1.50	12.00	\$25.00
Lil. Tigrinum Flore Plena (Double Tiger Lily)	1.00	7.50	60.00

Large Imported Bulbs

Write for our "Florist's Catalogue"

Headquarters for LIL. FORMOSUM

Henry F. Michell Co., 1018 MARKET STREET Philadelphia, Pa.

Aster Seed!! Have You All You Need??

If you still have an order to send:—DO NOT DELAY, SEND IT TODAY. We are now sold out of our Special Giant Comet. Some of the other varieties are almost sold out. All seed grown by us in 1907.

Aster Book and Competition Card for Great Aster Growing Contest, Free.

ALTIMO CULTURE CO., = CANFIELD, OHIO

Thorburn's Seeds

Seeds of ASPARAGUS PLUMOSUS NANUS, \$2.00 per 1000.
 Seeds of ASPARAGUS PLUMOSUS ROBUSTUS, \$2.00 per 1000.
 COLD STORAGE LILY OF THE VALLEY PIPS
 JAPAN LILIES, JAPAN IRIS

For prices, state quantities required.

J. M. THORBURN & CO.
 33 Barclay St., through to 38 Park Place
 NEW YORK

Best Quality Fall Bulbs

It is to your advantage to place your order early. Send us a list of your wants and we will quote you rock-bottom prices. Copy of our Florists' Bulb Catalogue will be sent upon request. Catalogues now ready.

VICK'S SUPERB PANSY SEED

All the best varieties in separate colors

VICK'S SUPERB MIXTURE

the best strain from all the leading named sorts
 1-8 oz. 75c. 1-4 oz. \$1.50 Ounce \$5.00

JAMES VICK'S SONS, Rochester, N. Y.

PRIMULA, FRINGED SINENSIS

This seed has been grown for us by a specialist in the culture of Primula, and he has produced plants of sturdy growth, large, thick flowers beautifully fringed and carried on erect stems well above the foliage, unexcelled in size, substance and beautiful colors.

Giant Perfection Strain, Finest Mixed, 1-64 oz., \$1.00
 Pure White, Brilliant Pink, Blue, Chiswick Red, and
 Crimson, 1-64 oz., \$1.00.

H. E. FISKE SEED CO.

13 Fenwick Hall Sq., BOSTON, MASS.

Prices quoted in these columns are for Dealers Only. When writing to Advertisers Please Mention HORTICULTURE.

QUALITY SEED BULBS PLANTS
 SEND FOR CATALOGUE
ARTHUR T. BODDINGTON
 349 West 14th St., New York.

LANDRETHS' SEEDS

ONION SEED	EXTRA EARLY RED FLAT RED WETHERSFIELD DANVERS GLOBE STRASBURG YELLOW PRIZE TAKER	LOW PRICES ON APPLICATION

BLOOMSDALE SEED FARMS, Bristol, Penna.

C. C. MORSE & CO.

Address all communications to our permanent address
 48 to 56 Jackson St., San Francisco, Cal.

The Largest Seed Growers in the United States

BRECK'S SEEDS

For Farmer, Market Gardener and Florist
 New Crop High Grade
 Catalogues mailed free on application

Joseph Breck & Sons Corp.
 47-54 NO. MARKET ST., BOSTON, MASS.

CAULIFLOWERS SEED CABBAGE

HJALMAR HARTMANN & CO.,
 12 Stormgade,
 COPENHAGEN, DENMARK.

Burpee's Seeds

PHILADELPHIA

Blue List of Wholesale Prices mailed only to those who plant for profit

BRASLAN SEED GROWERS CO.

GROWERS FOR THE
 WHOLESALE TRADE ONLY
SAN JOSE, - - CALIFORNIA

RELIABLE SEEDS

SOW NOW

Ageratum Mexicanum Blue Star—
 Tr. Pkt. 25c. 6 Tr. Pkts., \$1.25.
Lobelia Erinus Pendiculata Hamburgia
 Tr. Pkt. 30c. 6 Tr. Pkts., \$1.50.
Primula Obconica Grandiflora—
 New Hybrids: Blood-red, Blue, Carmine, Pink,
 Purple, Violet, Pure-white, Compacta, Gigan-
 tea, Fringed Mixed Hybrids, each separate,
 Tr. Pkt. 50c. 6 Tr. Pkts., \$2.50.

My Catalogue will guide you through Reliable Seeds.
 Ask for Same.

O. V. ZANGEN
 SEEDSMAN, HOBOKEN, N. J.

Vegetable and Flower **SEEDS**
 Reliable and Tested. Catalogue Mailed Free
WEBER & DON
 Seed Merchants 114 CHAMBERS STREET
 NEW YORK

JUST ARRIVED LARGE SHIPMENT OF High-Grade SCOTCH SOOT.

We have the Stott Double Nozzle
THOMAS J. GREY CO.
 32 & 33 So. Market St., BOSTON

BRIDGEMAN'S SEED WAREHOUSE RICKARDS BROS.

Props.
 37 East 19th St., - NEW YORK CITY

BAMBOO CANES TOUGH AND STRONG

6 ft. long—\$1 per 100; \$6 per 1000; \$11 per 2000

They cost about 10 per cent. more than other kinds, and they are 10 times better.

STUMPP & WALTER CO., - 50 Barclay St., New York



Mr. FLORIST
Why Don't
You Sell

VASES

Every vase sold
means more
business for you

This Business
belongs to you

Will you let us
show you how
to get it?

Write for
Catalogue "B"
on VASES

**The Kramer
Bros. Fdy.
Company**
DAYTON, O.

Largest Mfg. of
Vases in the U.S.

Martial Bremond

WHOLESALE GROWER OF FRENCH BULBS

— OLLIOULES, FRANCE —

A superior quality supplied at
market prices. Shipments made
direct. Cases marked to order.

Sole Agents

RALPH M. WARD & COMPANY
12 West Broadway - - NEW YORK

CHRYSANTHEMUMS

All the Popular Varieties.

Rooted Cuttings, per 100, \$1.00; per 1000, \$8.00

GERANIUMS

A Large Assortment of the Choicest Kinds.

From 3 1/2 in. pots, \$7.00 and \$8.00 per 100.

WM. W. EDGAR CO., Waverley, Mass.

GLEANINGS FROM THE CHICAGO PLANT GROWERS.

Tausendschon proved itself one of the best new roses for Easter trade. The beautiful pink flowers grow lighter with age and show different shades on the same plant. One of its best characteristics is its ability to stand handling without dropping its petals. Those who grow it this year will grow many more next year for, as a pot plant, it is a success. Pink Baby Rambler does not gain in popularity because the petals drop so easily. White Baby Rambler has the same defect. Dorothy Perkins and Lady Gay were fine for Easter pot plants and the large specimen plants sold readily for decorating the windows of the retail stores. Clothilde souvert came in nicely for Easter trade but is not quite satisfactory as it requires very careful handling. Richmond does not make a good pot plant.

Rhododendrons were fine for show plants but not much money in them for the grower. Azaleas brought good prices and with hydrangeas made a showy stock that nothing could surpass.

Additional orders showing trade was better than anticipated came in until Saturday night. The smaller and less perfect plants sold to the department stores and everything was cleaned up.

All around, the growers are pleased with the Easter trade. Though they had an immense stock they could have sold more. One of the largest growers said trade was the best he had ever enjoyed.

Chicago florists had something of a weather scare Easter week. The wind

was in the south and the thermometer on Tuesday registered 84 degrees. Many looked anxious as they realized what it would mean to the Easter stock if the temperature remained so high. Wednesday morning was still very warm when the wind suddenly changed to the north and the thermometer rapidly fell, dropping 17 degrees in one hour, and before night registered 54 degrees lower than in the morning. It was hard on the men who had left their overcoats at home but the Easter stock was saved. Easter Sunday the weather became warm and delightful.

PLANT IMPORTS.

Via Liverpool: A. Murphy & Co., 3 cs. plants; Sundry Forwarders, 12 bales trees.

Via Havre: C. C. Abel & Co., 13 pgs. plants; H. F. Darrow, 6 pgs. do.; C. W. Leavitt & Co., 6 pgs. trees. Maltus & Ware, 3 cs. plants.

Via Southampton: C. C. Abel & Co., 48 cs. plants; H. F. Darrow, 1 cs. do.; Maltus & Ware, 2 cs. do.; A. Rolker & Sons, 1 cs. do.; Wadley & Smythe, 31 cs. do. and 9 baskets do.; Sundry Forwarders, 18 cs. do., 14 pgs. do.

Via London: To Order 2 cs. orchids.

From Germany: Gerhardt & Hay, 1 cs. trees; R. F. Lang, 22 hskts. plants; Sundry Forwarders, 79 hskts. trees, 1 cs. plants.

From Glasgow: T. Meadows & Co., 1 cs. gooseberry bushes.

Via Southampton: C. C. Abel & Co., 16 cs. plants; H. F. Darrow, 21 pgs. seed; Sundry forwarders, 26 cs. plants

EASTER PLANT TRADE IN PHILADELPHIA.

Some say it was very good, some say only moderate, others very bad. It was good in spots but not up to standard even in the good spots. The moderate and poor spots hated to own up that they came under that category and the reviewer had to use his eyes and judgment rather than listen to the rose-colored accounts. No one wanted to admit that there was anything the matter with his particular spot. On the whole it may be put down as a settled and incontrovertible fact that there were more lilies, azaleas, spireas, hyacinths, cinerarias, and other Easter plants grown for this market than ever before. 1907, and the years immediately preceding, had been on the as ending scale as to consumption and the preparations for 1908 were for an even larger trade. Instead of that, the buying power of the public has been largely curtailed this year, and so we have had twice as much stock as the market could absorb, with consequent demoralization in prices. The regular flower stores did fairly well. The larger growers who supply the highest class trade also did well. But the enormous army of street vendors, druggists, grocers, butchers, and what not—as well as the outlying florists with a local trade—suffered severely. By Saturday afternoon, when the rain commenced, half the stocks were still unsold and then came a stampede. Prices went to pieces completely and many couldn't even give the stuff away. There was far too much of everything—but lilies were the worst! Many growers reported losses of 50

CATTLEYA TRIANAE

Just to hand in perfect condition, a large shipment which we offer in cases containing about 40 fine plants aggregating over 450 bulbs, for \$55 per case.

Also CATTLEYA LABIATA in cases of 400 bulbs, for \$55 per case.

Also ONCIDIUM VARICOSUM ROGERSII, at \$18 per dozen.

LAGER & HURRELL, - - Summit, N. J.

per cent. on their bulbs planted and even at that there were 50 per cent. more than the market needed. Even for a prospective good season the over-planting of lilies last fall, as indicated by this influx, must have been simply absurd. Now we will see everybody rushing to the other extreme in placing next season's order. Lilies will be wanted next year but it is best to be on the safe side and go slow. That is far from dropping them altogether and rushing off to something else in a panic—just because indiscreet over-planting has been indulged in. Among novelties that met favor was the new Rambler rose "Tansendschon" and the snow-white *Hydrangea aborescens*. Some large plants of *bougainvillea* were to be seen but we have not heard of any sales. Azaleas were never better as to quality. The miniature crimson azaleas *Hexe* and *Hinodegeri* were particular favorites for made-up baskets. *Ericas* were seen here and there in moderate quantity and *Farleyense* and *Amerpohli* and *Whitmani* ferns were used with fine effect. Square terra cotta vases of a rough finish and natural grey in color with raised ornaments were a novelty and sold well when filled with well-arranged plant combinations. The birch basket was seen in great variety. Some lovely Dorothy Perkins and Lady Gay roses were seen in the select stores. *Leutzia crenata* fl. pl. was in moderate supply while the more common *gracilis* was exceedingly plentiful. Hybrid roses such as *Brunner*, *American Beauty*, *Mrs. Laing* and *Paul Neyron* were in good supply but the demand was not particularly brisk. Pot gardenias and jasmines in meagre supply and with little call. *Genistas* less in evidence than ever this year. *Crimson Ramblers* were plentiful and in general very well done. These cleaned up better than many other stocks. *Rhododendrons* sold well especially the new one—*Pink Pearl*. Foliage plants were little called for separately, but many of the smaller sizes of palms, crotons, dracenas, and ferns, were used in made-up work.

The opening of the new establishment of J. H. Orth, McKeesport, Pa., on April 4, was a great success and throngs of people were in attendance. Several thousand carnations were presented as favors to the guests.

In ordering goods please add "I saw it in HORTICULTURE."

ORCHIDS

Largest Importers, Exporters, Growers and Hybridists in the World

Sander, St. Albans, England and 235 Broadway, Room 1 NEW YORK CITY

ORCHIDS

Arrived in superb condition, a magnificent consignment of *Den. Formosum giganteum*, *D. Wardianum*. These are indeed fine plants. Will arrive April 15. *C. labiata*, *C. Trianae*, *C. gigas Sanderiana*. To arrive about May 1 to 15, *C. Mendellii*, *C. Schroderae*, *Mossiae*, *Gaskelliana*, *Percivaliana*. A trial order will prove we carry the best stock that can be secured.

CARRILLO & BALDWIN Secaucus, N. J.

Imported Orchids

JUST TO HAND

Laelia Purpurata
Cattleya Intermedia
Cattleya Mossiae

JULIUS ROEHR'S CO.,

The Orchid Nurseries RUTHERFORD, N. J.

ORCHIDS for Spring Delivery

NEW IMPORTATIONS

Cattleyas, *Laelias*, *Oncidiums*, etc.

WRITE FOR PRICES

Now is the time to Pot Orchids. Best Quality of Peat, Moss and Baskets on hand.

JOSEPH A. MANOA, 191 Valley Road, WEST ORANGE, N. J.

ORCHIDS

The largest importation of Orchids ever received in this country WILL ARRIVE next spring from Brazil, Colombia and Venezuela. If you intend putting in stock wait for these to arrive and we will quote the Lowest Prices in America.

ORRONEZ BROS., - Madison, N. J.

NEPHROLEPIS SCOTTII

in the following sizes, extra good value

25c., 50c., 75c., and \$1

Grand Specimen Plants at \$3, \$4, \$5, \$6.

JOHN SCOTT

Rutland Road and E. 45th St.

Tel. 2890 Bedford BROOKLYN, N. Y.

In ordering goods please add "I saw it in HORTICULTURE."

HYACINTHS, TULIPS, NARCISSI

AND OTHER BULBS

ROMAN HYACINTHS and the true

PAPER WHITE GRANDIFLORA

Ask for our Wholesale Trade List at Hillegom

K. VELTHUYS, Hillegom, Holland

Rep. by FELIX BOSCH, 260 Clarendon St., Boston.

Extra good value in

Decorative Plants

Azaleas, Kentias, Rubbers, Arcas
Araucarias, Pandanus, Box Trees,
Euonymus, Crotons, and
Eurya latifolia.

A Leuthy & Co.

Perkins Street Nurseries, Roslindale, Mass.

Gloire de Lorraine Begonia

2 1/4 inch pots, \$15.00 per 100
\$140.00 per 1000

Thomas Roland

Nahant - - Mass.

New Violet BOSTON

In introducing this new variety to the trade I wish to state that I have been growing it in quantity for the past two years and do not hesitate to state that it is entirely distinct, a strong grower, a free bloomer, and the finest single violet in cultivation. Ready for distribution in April and May. Orders booked now. \$2 per 12; \$12 per 100; \$100 per 1000. 500 at 1000 rate.

WILLIAM SIM, CLIFTONDALE, MASS.

In ordering goods please add "I saw it in HORTICULTURE."

NEP. WHITMANI

2 1/4 in., \$5.00 per 100

NEP. WHITMANI

3 1/2 in., \$25.00 per 100

BOSTON FERNS

2 1/4 in., \$3.00 per 100

H. H. BARROWS & SON Whitman, Mass.

Ipomoea Noctiflora

Best pure white convine in market, very fragrant and useful as a saucer. On this variety we have a world-wide reputation as growers and shippers for the last twenty years. Price, 2 1/2 in. pots, \$5.00 per 100. 10,000 are now ready.

CODFREY ASCHMANN,

1012 W. Ontario St., Philadelphia, Pa.

JAPANESE

LILIES

PLANTS

BAMBOO STAKES

THE YOKOHAMA NURSERY CO.
31 BARCLAY STR. NEW YORK.

JOHN BREITMEYER'S SONS

Cor. Miami and Gratiot Aves.
DETROIT, MICH.

Artistic Designs . . .
High Grade Cut Blooms

We cover all Michigan points and good
sections of Ohio, Indiana and Canada

William J. Smyth FLORIST

Cor. Michigan Ave. and 31st St., CHICAGO

We ship to all points in Illinois and Iowa.

Phones: Douglas 744, Douglas 523, Douglas 740

M. G. and J. E. HAUSWIRTH

232 Michigan Ave.
CHICAGO

AUDITORIUM ANNEX Tel. Harrison 585

SAMUEL MURRAY Florist

Coates House Conservatory
1017 BROADWAY, KANSAS CITY, MO
Both 'Phones 2670 Main

FRED C. WEBER FLORIST

4326-28
OLIVE STREET ST. LOUIS, MO.
Established 1873
Long Distance Phone Bell Lindell 676



WASHINGTON,
D. C.

GUDE'S

Geo. H. Cooke FLORIST

Connecticut Avenue and L Street
WASHINGTON, D. C.

The Park Floral Co.

J. A. VALENTINE
Pres.

DENVER, COLORADO

WILLIAM L. ROCK FLOWER CO.

KANSAS CITY, - MO.

will carefully execute orders for Kansas City
and any town in Missouri or Kansas.

Of Interest to Retail Florists.

The retail stores were well stocked and presented a very attractive appearance. The cool weather during the latter part of the week made the stock in the best condition for handling. Many of the windows showed considerable originality. One was especially noted. The floor was covered with green moss and in the center was a little mound covered with Baby Rambler roses. A large specimen plant of Lady Gay very effectively covered the end of one window. Azaleas held the place of honor next to Easter lilies. One large retailer opened up a second store in anticipation of the Easter trade and reports his venture a great success. A few plants are left, some of them fine ones but it is impossible for the retailer to sell out as closely as the wholesaler and the left-overs are selling at half price to close out. The general opinion prevails among the retail men that the white flower was not a favorite for Easter except in the Easter lily. Among those who handle both the cut flowers and the pot plants the feeling is strong that pot plants are steadily gaining in favor as Easter offerings.

Primula obconicas were artistically arranged in baskets and fancy boxes and moved rapidly while specimen Lady Gay, Dorothy Perkins and Souper roses found ready sale. Like the wholesaler the retailer is glad Easter is over but rejoices in the hard earned dollars it has brought.

None of the retailers regret that Easter has become history. While it may take a few days yet to post up and ascertain the actual financial result, on one point all retailers agree. The fact seems to be that the quantity of business is ahead of last year but the quality is below. Prices averaged the same although somewhat lower in a few instances. This is borne out by the fact that large baskets, \$20 Beauties and other \$10 roses found very few buyers. Lilies, in pots as well as cut, and Baby Rambler roses found ready sales. Violets were not enough by far; one firm picked 48,000 and was completely sold out by 5 p. m., Saturday.

In Worcester, Mass., the Easter business among the retailers was fully equal to that of any previous year, and prices advanced but a trifle. The buying began practically a week before, when budded plants were given the preference. Violets were scarce and disappeared early, but primulas and pansies were abundant and proved great favorites. One dealer made a success of small roses arranged in a close, compact bunch with little foliage, for the corsage. The early buying, however, did not affect the final rush, for which the moderate prices, within the reach of all purses, may have been in a measure accountable.

NEW RETAIL FLOWER STORES.
E. E. Martin, Seal Harbor, Me.
Paul Niehoff, Manch Chunk, Pa.
Geo. T. Rand, Somerville, Mass.

Florists

Out of
Town

Taking orders for delivery in
New York or Vicinity
can have them filled in best
manner and specially deliv-
ered by * * *

Thomas Young, Jr.

500 Fifth Ave., New York City
Telephone 847 Bryant.

ALEX. McCONNELL

571 FIFTH AVENUE
NEW YORK CITY

Telegraphic orders forwarded to any
part of the United States, Canada, and
all principal cities of Europe. Orders
transferred or intrusted by the trade to
our selection for delivery on steamships
or elsewhere receive special attention.

Telephone Calls, 487 and 488 38th St.
Cable Address, ALEXCONNELL

WILLIAM H. DONOHUE

FLORAL DECORATOR

17 East 28th St., New York
Special Attention to Theatre
and Steamer Orders, and reliable
deliveries guaranteed.

DAVID CLARKE'S SONS

Deliver orders from any part of the country to
New York City

Or OUT-GOING STEAMERS

Write or telegraph

2139-2141 Broadway, New York
Telephone 1552-1553 Columbus

M. A. BOWE

In the Heart of New York City

1294 Broadway

Tel. 2270, 38th St. NEW YORK

Our Motto -- The Golden Rule.

YOUNG & NUGENT

42 West 28 St., NEW YORK

"FLOWERS BY TELEGRAPH"

Flower Deliveries

In Brooklyn and other Long Island Points
New York City, New Jersey, etc. At Theatres,
Hotels, Steamers or Residence.

WILSON

Fulton St. and Greene Ave., Brooklyn, N. Y.

ALBANY, N. Y.

EYRES

Flowers or Design Work

DELIVERED IN ALBANY AND VICINITY
ON TELEGRAPHIC ORDER.

11 NORTH PEARL ST., ALBANY, N. Y.

JACOB SCHULZ, 644 Fourth Ave.,
LOUISVILLE, KY.

Cut Flowers of BEST QUALITY in season
delivered promptly to any address.

Write, Telegraph or Telephone.

Cumberland and Home Phones 223 and 984

**PROMPT DELIVERY IN
BOSTON**
AND ALL NEW ENGLAND POINTS
HOUGHTON & CLARK
396 Boylston St., Boston, Mass.



BOSTON'S BEST
In Quality and Design
Can be relied upon when you transfer your retail orders to

EDWARD MACMULKIN
194 Boylston Street, Boston

Send flower orders for delivery in
BOSTON
and all
NEW ENGLAND POINTS
THOS. F. CALVIN
124 Tremont St., Boston

TRANSFER
Your orders for flower or plant delivery in Eastern New England to
JULIUS A. ZINN,
2 Beacon St., Boston.
Fine Design Work a Specialty

YALE Orders for flower deliveries to Yale College and all other Connecticut points carefully filled and delivered by
J. N. CHAMPION & COMPANY
1026 CHAPEL STREET NEW HAVEN, CONN.

Chicago. Established in 1857
WITTBOLD
FLORIST
1657-1659 Buckingham Place
L. D. Phone 558 Lake View. Send us your retail orders. We have the best facilities in the city.

The Far-Famed Flowers of
TORONTO
Delivered on mail or telegraph order for any occasion, in any part of the Dominion.
JOHN H. DUNLOP,
96 Yonge St., Toronto, Ont.

ATLANTA FLORAL CO.
41 Peachtree Street, ATLANTA, GEORGIA.
ROBERT J. DYSART,
Public Accountant and Auditor
Simple methods of correct accounting especially adapted for florists' use.
Books Balanced and Adjusted
Merchants Bank Building
28 STATE ST., BOSTON
Telephone, Main 38.

HART'S HANDY HANDLE

"At Easter-time, with a little chiffon decoration, and the Handle, we were able to increase the value of plants from 50% to 100%."—H. E. WILSON.

Write for descriptive circular and prices

GEO. B. HART, 24 Stone St., Rochester, N. Y.

EVERY FLORIST NEEDS IT Lewis's Weekly Board File



takes the place of Memo or Order Books, or a line of nails. Just the thing for Sales Slips, Orders to be filled, etc. The Board File is made up of sets of our Spring Spindle File as illustrated herewith. Among the prominent Florists now using it are:

H. H. Ritter, Dayton, O.; W. C. Stickel, Pres. Park St. Flower Market, Boston; Edw. Wood, Pres. Music Hall Flower Market, Boston; J. C. Hatcher, Amsterdam, N. Y.; F. S. Follwe, Pittsfield, Mass.; I. L. Powell, Millbrook, N. Y.; Kensington Flower Shop, Boston; T. F. Calvin, Boston, Mass.

50,000 In Use.

See Large Ad. Horticulture, page 504, April 11, 1908.

A. F. LEWIS MFG. CO., E. Boston, Mass.

Easter Market Reports

DETROIT Local wholesalers report a greatly increased Easter trade with an unprecedented demand for violets and roses. The former were sold out by Saturday noon; one firm alone had 125,000. A very strong demand cleaned lilies up rapidly; the supply was somewhat weakened by heavy shipments up-state of potted lilies. Of carnations there were about enough to go around, bringing mostly \$2.00 per 100, a comparatively small quantity selling at \$1.00 per 100. All bulbous stock was in good demand but the enormous supply on hand made it a drug after all. Greens of all descriptions found buyers readily. Prices averaged same as last year.

INDIANAPOLIS The Easter trade is reported as generally favorable with a clean-up in plants as well as cut flowers. There was an abundance of good stock in all lines. There was a slight advance in price of Beauties, teas and carnations, but the volume of stock was handled at conservative figures. The heaviest call was for Easter lilies, both cut and pot. There was a good supply of these, the largest proportion of which was rather short-stemmed. While there were no novelties in the plant line, a more complete list has never been shown with results most gratifying. An abundance of lily of the valley, sweet peas, some orchids and an unlimited supply of bulbous stock sold well. The amount of business totalled up about equal to previous years, notwithstanding the fact that no top-notch prices were received.

PHILADELPHIA Easter week trade, taking stocks all along the line was as good as last year in cut flowers as far as volume was concerned but prices were of course very much under the average. The only flower that did any soaring was the orchid. Orchids were quite scarce and in sharp demand with prices in sympathy. Roses were equal to requirements and showed no great change in prices. Fancy long stem American Beauty were in large supply, mediums were scarce, and shorts poor in quality

and too many. Red and pink roses went even better than the whites, which is unusual for Easter. Carnations were in good supply and moderate in price. Double violets are still fairly plentiful, the Rhinebecks now helping out the decreasing locals. Immense quantities of lily of the valley consumed and yet no upward movement in prices. More people have gone into growing this crop—not only locally but at distant shipping points that used to consume much of the surplus. Mignonette is a glut. White daisies ditto. Yellow daisies the best sellers. Sweet peas continue fine and went all right. Greens were in good supply and fair demand. As a catch crop for Easter, Brimmer and Druschki roses were welcome. The Druschki is not a very good carrier—bruises too easily. But no white can beat it for purity.

INCORPORATED.

Martin & Forbes Co., Portland, Ore.; W. Martin, James Forbes, George Spencer; capital, \$50,000.

BOSTON FLORIST LETTER CO.

Manufacturers of FLORISTS' LETTERS

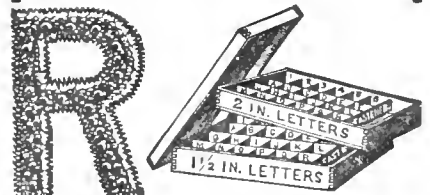

This wooden box nicely stained and varnished, 18x30x12, made in two sections, one for each size letter, given away with first order of 500 letters

Block Letters, 1 1/2 or 2 inch size per 100, \$2. Script Letters, 3. Fastener with each letter or word. Used by leading florists everywhere and for sale by all wholesale florists and supply dealers

N. F. McCARTHY, Manager
66 Pearl Street, BOSTON, MASS.

KORAL SCRIPT LETTERS AND EMBLEMS

ONCE USED ALWAYS USED
For sale by all first class supply houses. Made by

KORAL MFG. CO.
26 Hawley St., Boston

GOOD VALUE

Kaizerins, Brides, Gates, Bridesmaid

Our stocks of these are extra quality at present, and at \$6 and \$8 per 100 are splendid value.

The Leo Niessen Company
1209 Arch St., Philadelphia, Pa.
Open from 7 a. m. to 8 p. m.

For After Easter Weddings

CHOICE VALLEY, \$3 and \$4 per 100
GARDENIAS, \$2.50 and \$3 per doz
SWEET PEAS, 75c. and \$1 per 100

S. S. PENNOCK-MEEHAN CO.
1608-1620 Ludlow St. PHILADELPHIA
"The" Wholesale Florists of Philadelphia

EVERYTHING SEASONABLE IN
CUT FLOWERS
EDWARD REID, Wholesale Florist
1526 Ranstead St., PHILADELPHIA
STORE CLOSES 8 P. M.

CHAS. W. MCKELLAR
51 WABASH AVE., CHICAGO
Western Headquarters for Choice Orchids
Valley, Roses and all Cut Flowers

PETER REINBERG
WHOLESALE
CUT FLOWERS
51 Wabash Av., Chicago, Ill.

CUT FLOWER BOXES
EDWARDS FOLDING BOX CO
MANUFACTURERS
PHILADELPHIA, PA.

AMERICAN BEAUTY and all other ROSES
LILY OF THE VALLEY, CARNATIONS
WELCH BROS., 226 Devonshire St., Boston, Mass.

VIOLETS
Fancy Double Rhinebecks
W. E. MCKISSICK WHOLESALE FLORIST
PHILADELPHIA
1619-1621 RANSTEAD ST.

DAILY CONSIGNMENTS
From 40 to 60 Growers
We can care for your cutflower wants to advantage.
E. F. WINTERSON CO.
45-47-49 WABASH AVE., CHICAGO

Rice Brothers
115 N. 6th Street, MINNEAPOLIS, MINN.
WHOLESALE FLORISTS and SUPPLIES
CUT FLOWERS received twice daily, and can fill your orders to your satisfaction. A complete line of Hardy Greens—WILD SMILAX, BOXWOOD, HARDY FANCY FERNS, GALAX LEAVES.
Write for quotations on large quantities.

H. BAYERSDORFER & CO.
The Florists' Supply House of America
Send for Illustrated Catalogue
1129 ARCH ST., PHILA., PA.

Alex Mann, Jr. Co., Inc.
Wholesale Dealer in
Florists' Supplies and Cut Flowers
White Doves, \$9.00 per doz.
Galax Leaves.
1125 Polk Street, San Francisco, Cal.

WHOLESALE FLOWER MARKETS—TRADE PRICES—Per 100 TO DEALERS ONLY

	CHICAGO April 20	TWIN CITIES April 20	PHILA. April 20	BOSTON April 23
ROSES				
Am Beauty, Fancy and Special...	25.00 to 45.00	40.00 to 50.00	25.00 to 30.00	20.00 to 25.00
" Exra.....	30.00 to 35.00	30.00 to 40.00	15.00 to 20.00	12.00 to 15.00
" No. 1.....	12.50 to 15.00	15.00 to 25.00	10.00 to 12.00	6.00 to 10.00
" Lower grades.....	4.50 to 8.50	8.00 to 15.00	5.00 to 8.00	4.00 to 6.00
Bride, 'Maid, Fancy & Special....	6.00 to 8.00	10.00 to 15.00 to 10.00	6.00 to 8.00
" Extra and No. 1.....	4.00 to 5.00	8.00 to 10.00	6.00 to 8.00	3.00 to 5.00
" Lower grades..... to 3.00	5.00 to 8.00	3.00 to 4.00	1.00 to 2.00
Killarney, Richmond, Fan. & Sp....	8.00 to 10.00	9.00 to 12.00	8.00 to 15.00	6.00 to 12.00
" Lower grades.....	4.00 to 6.00	5.00 to 8.00	3.00 to 5.00	2.00 to 6.00
Chat-nay, Wellesley, Fan. & Sp....	8.00 to 10.00	9.00 to 12.00	8.00 to 10.00	4.00 to 8.00
" Lower grades.....	4.00 to 6.00	5.00 to 8.00	3.00 to 5.00	1.00 to 3.00
Golden Gate, Ivory.....	4.00 to 8.00	8.00 to 10.00	3.00 to 8.00	1.00 to 6.00
CARNATIONS				
Fancy and Novelties..... to 3.00	5.00 to 6.00	2.50 to 4.00	2.00 to 3.00
Ordinary.....	1.00 to 2.00	4.00 to 5.00	1.50 to 2.00	1.00 to 2.00
MISCELLANEOUS				
Violets.....	.50 to .75	.75 to 1.25	.50 to .75	.50 to .75
Cattleyas.....	50.00 to 60.00 to 50.00	50.00 to 75.00	50.00 to 60.00
Cypripediums..... to to to	8.00 to 10.00
Lilies.....	12.00 to 15.00	12.50 to 15.00	8.00 to 10.00	6.00 to 8.00
Lily of the Valley.....	3.00 to 4.00 to 4.00	2.00 to 4.00	1.00 to 3.00
Daisies.....	.50 to 1.00	1.00 to 2.50	.50 to 1.00 to
Daffodils..... to 3.00	3.00 to 4.00	1.50 to 3.00	.50 to 1.00
Tulips.....	2.00 to 4.00	3.00 to 4.00	1.10 to 3.00	.50 to 1.00
Mignonette.....	4.00 to 6.00	4.00 to 5.00	2.00 to 3.00	1.00 to 2.00
Gardenias.....	20.00 to 35.00	40.00 to 55.00	25.00 to	25.00 to 40.00
Lilac per bunch.....	1.00 to 1.50	1.50 to 2.00	1.50 to 50.00	.50 to .75
Sweet Peas.....	.50 to .75	.75 to 1.25	.50 to 1.00	.25 to .50
Adiantum.....	.75 to 1.00 to 1.50	1.00 to 1.50	1.00 to 1.50
Whitmaoil Froods..... to to	3.00 to	2.00 to 3.00
Smilax.....	12.00 to 15.00	12.00 to 18.00	15.00 to 20.00	10.00 to 12.00
Asparagus Plumosus, strings.....	35.00 to 50.00	35.00 to 40.00	5.00 to	25.00 to 50.00
" & Spren. (100 bchs.)	35.00 to 50.00	35.00 to 40.00	5.00 to	25.00 to 50.00

J. A. BUDLONG
37-39 Randolph Street, CHICAGO.
Roses and Carnations WHOLESALE CUT FLOWERS
A Specialty..... GROWER of

E. A. BEAVEN
Southern Wild Smilax,
Log Mosses,
Natural and Perpetuated— at Wholesale,
EVERGREEN, ALABAMA.

J. B. Murdoch & Co.
Wholesale Florists
FLORISTS' SUPPLIES
714 Penn Ave., PITTSBURG, PA.
Long Distance Phone 1435 Court.

EASTER MARKET REPORTS

While it is true that some **BOSTON** growers were badly left on lilies and rambler roses and some retailers report a heavy left-over accumulation of both plants and flowers, and while it is also a fact the enormous avalanche of material brought to the wholesale markets on Saturday morning had, in many instances, to be unloaded at bargain-counter prices, yet our observation leads us to agree substantially with those who say that, as a whole, Boston's Easter was a satisfactory one. Nobody claims that it exceeded or equalled last year in amount of business done, but the truth is that nobody expected it would, and all were agreeably disappointed in getting as much as they did. The plants presented for the critical buyers of the Hub were, as a rule, the best ever offered in this market. They were of the usual Easter varieties, the only absolutely new subject coming to our notice being some handsome pots of crimson clover in bloom. In the plants left over on the hands of retailers, lilies, hydrangeas and azaleas predominated, yet the number of these specialties sold was so enormous that the unsold material was of comparatively little consequence, and the record of recent years to the effect that Easter is practically a plant holiday was not disturbed. The receipts of cut flowers were the largest ever. No previous Easter could show anything to compare with this. Under the circumstances it is not surprising that all kinds of expedients had to be resorted to in the struggle to keep the decks cleared on Saturday as shipment after shipment in inexhaustible supply came to hand. The best sellers were violets, red carnations and Richmond roses; the worst sellers were Bride and Bridesmaid roses, white carnations, stocks and white material generally and, worst of all, bulbous stock. Killarney, Beauty and any bright colored roses sold fairly well; of these, however, and of lilies there were considerable left in retailers' hands, the wholesalers having succeeded in unloading pretty clean on these items. Lilies at wholesale held at top-notch figures except where excessively short-stemmed, in which case they encountered trouble. There was less complaint concerning stale flowers than heretofore. The widespread conviction that prices would not advance for Easter was undoubtedly responsible for this pleasant experience.

Ideal spring weather **BUFFALO** opened up Easter week and continued until Thursday, giving all the plants in bud ample time to open for the expected rush, the real sale days being Friday and Saturday. The market was well supplied with plants as well as cut flowers. In the plant line, azaleas, Crimson and Baby Ramblers and lilies were the main features, while other stock also moved well. In the cut flower line there is much to be said. Violets had the best cleaning up in some time, the quality being good. All orders were filled complete, and in other stock such as carnations, roses

and bulbous flowers, there was plenty to be had and all of good quality, but prices not up to previous years. Beauties were in good supply, but demand not heavy. Richmonds sold out clean. Killarney, Kaiserin, Carnot and others were seen in quantity and up to Saturday were well moved. The man growing bulbous stock got very little in return; in this line there was no demand whatever. As for the lily of the valley it had the best cleanup in years for the wholesaler, but good portions of mignonette were unsold and carried over. Sweet peas, gardenias, snapdragon, lilacs and orchids sold well. Of carnations there were enough to be distributed and all of good quality; on this line the demand was good. The shipping trade was excellent both in cut stock and plants, but had not three days of rain come at the end of the week there would have been much less stock to carry over.

Wieland & Risch:
CHICAGO "Trade fine; too tired to even estimate it, but know it was good. White flowers a little slow."

E. H. Hunt: "Trade even better than we anticipated. Prices on cut flowers not up to last year but totals show up well."

Bassett & Washburn: "Easter trade in advance of last year. Demand for pot plants growing."

Poehlmann Bros. "Cleaned up on flowers but prices lower than last year."

Lloyd Vaughan: "Perfectly satisfied with results. Demand for pot plants growing."

Mr. Kruchten: "Flower sales not up to average. Pot plants sold well."

Mrs. Frank Ben: "Plant trade growing. Sales of cut flowers will not equal those of last year."

Mr. Bentley: "Easter trade satisfactory. Colored stock sold well but white flowers were a drag. Beauties scarce and in demand."

Peter Reinberg: "Big demand for Richmond roses. Could have sold many more. Also unusual demand for Beauties for Easter."

Mr. Weitor: "Up to my expectations."

Chas. McKeelar: "Easter trade very fair."

J. A. Budlong: "Easter trade very good."

E. F. Winterson: "Carnations too plentiful and made prices low but trade on the whole was fair, and better than anticipated."

J. B. Deamud: "Trade satisfactory."

New York's Easter **NEW YORK** was not much of a record breaker yet it did well, everything considered. The record breaking, such as it was, came on the wrong side, unfortunately. Never before has the Easter lily been so thoroughly knocked out. There was a slight apprehension in some quarters, beforehand, that trouble was in store, and that it would be the part of wisdom to unload stock as early as possible at moderate figures, but there were others, with equal opportunities for scanning the field, who insisted that lilies would make a good finish, in time-honored style, and scouted the idea of anything but top prices. Those growers and dealers who sold out early had good cause to congratulate themselves, even though they had been obliged to accept prices unprecedentedly low for first-class lilies. Saturday had not half gone when it became evident that a lily slaughter was imminent, and before night he who could get four or five dollars a hundred had reason to rejoice, while thousands of blooms were left over, on plants or cut, to be unloaded on Sunday and Monday for two dollars a hundred. It was certainly a great disappointment and also a great surprise and its full significance is not yet comprehended. The wonderful recuperative power of the New York flower market has often been commented upon, but one never knows what particular vein it will strike. This time the violet was the lucky item. After a month of degradation, hardly worth a dollar a thousand on the street the violet rebounded to old-fashioned Easter values and, although the shipments were heavy and the weather rather unpropitious for violet wearing, the prices held strong to the last and everything went. Roses were in reduced supply and this helped the rose market so that a reasonable record was made. Carnations were, perhaps, in lighter quantity than they had been, but there were lots of them and they cleaned up much better than seemed probable. Bulbous stock has a certain appropriateness for Easter and the sale of daffodils, tulips, hyacinths and lily of the valley was fairly good, but at low figures. There were but few orchids in sight, gardenias were also few in number, and among the choicest things offered were the crested moss rosebuds which brought \$1.50 per bunch of six or eight sprays, while the common moss buds went slowly at half that figure. The variety of unusual things—odds and ends, etc. was quite extensive and all the re-

(Continued on page 51)



Bostrom Improved Builders' Levels and Farm Levels

For Park, Cemetery and Landscape Gardening use, take the place of expensive Engineering Instruments. Simple in construction, easily adjusted, more substantial and less cumbersome than the more elaborate and complicated instruments. Practical, up-to-date instrument that any one can use. Write for descriptive circulars and be convinced that this Level is necessary to complete your outfit. Builders' Level \$25.00. Farm Level \$17.50.

BOSTROM-BRADY MFG. CO., 139 Madison Avenue, ATLANTA, GA.

The KERVIN CO. 113 W. 28th St. New York
WHOLESALE DEALERS
 Fresh cut Palmetto & Cycas Palm Leaves, Galax, Leucanthus, Ferns and Mosses. All Decorating Evergreen.

Look at List of
NEW OFFERS
 Page 580

JOHN YOUNG
WHOLESALE FLORIST
 Finest American Beauties and Carnations
 51 West 28 St. - NEW YORK

FORD BROTHERS
 48 West 28th Street, NEW YORK
FINE ROSES FANCY CARNATIONS
 A Full Line of All CUT FLOWERS
 Telephone, 3870 or 3871 Madison Square

H. E. FROMENT,
 Wholesale Commission Florist,
 Choice Cut Flowers,
 57 West 28th St., :: NEW YORK.
 Telephones: 2200, 2201, Madison Square.

The Reliable Commission House
 Richmond Roses and Rich Flowers
 of all varieties
JOS. S. FENRICH
 110 W. 28th Street, New York
 Tel. 324-325 Madison Square

Alfred H. Langjahr
 All choice cut-flowers in season. Send for quotations. Correspondence with shippers of first-class stock invited.
 55 West 28th Street, New York.
 Telephones 4626-4627 Madison Square

JOHN I. RAYNOR
Wholesale Commission Florist SELLING AGENT FOR LARGEST GROWERS
 A full line of Choice Cut Flower stock for all purposes. Comprises every variety grown for New York market, at current prices
 TEL. 1998 MADISON SQUARE 49 W. 28 St., New York City

Walter F. Sheridan
 Wholesale Commission Dealer in
CHOICE CUT FLOWERS
 39 West 28th Street, New York
 Telephone: 3532-3533 Madison Square

HEADQUARTERS FOR NOVELTIES
ORCHIDS A SPECIALTY
 THE HIGHEST GRADE OF **VALLEY** ALWAYS ON HAND
 GARDENIAS, DAISIES, ROSES AND CARNATIONS
 Telephone 759 Mad. Sq.
JAMES McMANUS, 42 W. 28th St., New York

PHILIP F. KESSLER 55 & 57 W. 26th St., New York City
 Commission Dealer, Wholesale Buyer and Seller of
CUT FLOWERS
 Open from 5 a. m. to 6 p. m. Sunday till 10 a. m.
 Tel., 5243 and 2921 Madison Sq. Res., 345 J., Newtown.
Finest Lilies in the Market Every Day in the Year.

WHOLESALE COMMISSION FLORIST
J. K. ALLEN 106 W. 28 ST. NEW YORK
 Telephone 167 Madison Sq.
 OPEN 6 A. M. DAILY
 We have a good regular outlet for seasonable flowers

NEW YORK QUOTATIONS PER 100—TO DEALERS ONLY

	Last Half of Week ending April 18 1908	First Half of Week beginning April 20 1908		Last Half of Week ending April 18 1908	First Half of Week beginning April 20 1908
Roses			Cattleyas	40.00 to 60.00	40.00 to 60.00
Am. Beauty, fan and sp.	15.00 to 30.00	15.00 to 25.00	Cypripediums	8.00 to 10.00	8.00 to 10.00
" extra	10.00 to 12.00	10.00 to 12.00	Lilies	4.00 to 8.00	4.00 to 6.00
" No. 1	6.00 to 8.00	5.00 to 8.00	Lily of the Valley	1.00 to 2.00	1.00 to 2.50
" Lower grades	1.00 to 3.00	1.00 to 3.00	Daisies	1.00 to 1.00	.25 to 1.00
Bride, 'Maid, fan and sp.	6.00 to 8.00	4.00 to 6.00	Dianthis	1.00 to 1.50	1.00 to 2.00
" extra	4.00 to 5.00	2.00 to 4.00	Tulips	1.00 to 2.00	1.00 to 2.00
" lwr. grds.	1.00 to 2.00	1.00 to 2.00	Alphonette	1.00 to 2.00	1.00 to 2.00
Killarney, Richmond, fancy & spec	8.00 to 10.00	5.00 to 10.00	Gardenias	25.00 to 50.00	20.00 to 50.00
" lower grades	1.00 to 5.00	1.00 to 3.00	Lilac p r bunch	.50 to .75	.20 to .35
Chateau, Wellesley, fan. and spec.	4.00 to 10.00	4.00 to 8.00	Sweet Peas per 100 bchs.	3.00 to 8.00	3.00 to 8.00
" lower grades	1.00 to 2.00	1.00 to 2.00	Adiantum	.50 to .75	.50 to .75
Golden Gate, Ivory	1.00 to 6.00	1.00 to 6.00	Smilax	10.00 to 15.00	12.00 to 15.00
Carnations, Fancy and Novelties	2.00 to 4.00	2.00 to 4.00	Asparagus Plumosus, strigs.	20.00 to 30.00	15.00 to 25.00
" Ordinary	1.00 to 2.00	1.50 to 2.00	" " & Spreu. (too bchs.)	20.00 to 25.00	15.00 to 25.00
Violets	.40 to .75	.40 to .75			

B. S. SLINN, Jr.
 —WHOLESALE FLORIST—
 55 & 57 W. 26th St., New York City
 Tel., 3864 Madison Sq. Shipping Orders Solicited.
VIOLETS Roses and Carnations

Edward C. Horan
Wholesale Florist
 55 WEST 28th ST.
 Tel. 1462 1463 Madison Square New York

TRAENDLY & SCHENCK
WHOLESALE FLORISTS
 Furnish best stock at fair prices all the year round Send for quotations on fall orders
 Tel. 798.799 Madison Sq. 44 West 28th Street, New York City

Alexander J. Guttman
THE WHOLESALE FLORIST OF NEW YORK
 43 WEST 28th STREET
 PHONES. 1664--1665 MADISON SQUARE
ENOUGH SAID



HARDY CUT FERN

Sphagnum Moss, Extra Large Bales, per bale, \$1.25. Fancy and Dagger Ferns our specialty. A trial order will convince you that we ship only first-class stock. Headquarters for Florists' supplies and wire work. All cut flowers in season. BOXWOOD, per bunch 35c, 50 lbs. \$7.50.

MICHIGAN CUT FLOWER EXCHANGE, INC., All 'phone connections 38-40 Broadway, Detroit, Mich.

FANCY and DAGGER
Extra fine, \$1.75 per 1000. Bronze and Green Galax, \$1.25 per 1000. Leucothoe Sprays, \$1.00 per 100, \$7.50 per 1000.

Headquarters in Western New York

FOR

ROSES, CARNATIONS

And all kinds of Seasonable Flowers

Wm. F. Kasting Co.

Wholesale Commission Florist, also Dealer in Florists' Supplies and Wire Designs.

383-87 ELLICOTT ST. BUFFALO, N. Y.

Give us a trial. We can please you.

FRANK S. HICKS & CO.
Wholesale Florists.

Open Now for Consignments of Cut Flowers.

52 West 28th Street, - New York City

Tel. 2920 Mad. Sq.

FRANK MILLANG
Wholesale Florist

Telegraphic Orders Filled and Delivered.

55-57 West 26th St., New York City.

HENRY M. ROBINSON & CO.

Wholesale and Commission
FLORISTS

Hardy Cut Evergreens and Florists' Supplies

15 Province St. and 9 Chapman Place,
BOSTON, MASS.

Flowers and
Florists' Supplies

The best place in AMERICA to buy

BAY TREES

N. F. McCarthy & Co.

84 Hawley St., BOSTON, MASS.

Largest Dealers in Supplies in New England.

SAMUEL A. WOODROW

WHOLESALE PLANTSMAN

Palms, Large and Small Ferns, etc.

53 West 30th Street, NEW YORK

Telephone 2083 Madison

WILLIAM H. KUEBLER

Brooklyn's Foremost and Best

WHOLESALE COMMISSION HOUSE

A First Class Market for all CUT FLOWERS

28 Willoughby St., Brooklyn, N. Y.

Tel. 4591 Main

CLEARY'S HORTICULTURAL CO.

Management AMBROSE T. CLEARY

Wholesale Contracting, Jobbing, Auction

HORTICULTURAL PRODUCTS

of every description.

Consignments Received. Surplus Stock Converted.

62 Vesey St., NEW YORK

Moore, Hentz & Nash,

Wholesale Commission Florists,

55 and 57 West 26th Street,

Telephone No. 756
Madison Square.

New York.

H. C. BERNING

Wholesale Florist

1402 Pine Street, ST. LOUIS, MO.

MILLANG BROS.

WHOLESALE COMMISSION FLORISTS

41 West 28th Street

Telephone 3860
3861 Madison

NEW YORK

A. MOLTZ

Will purchase flowers on order in N. Y. market and ship carefully at prevailing wholesale prices. Address

55-57 West 26th Street, New York City

REED & KELLER
122 West 25th St., New York

Florists' Supplies

We manufacture all our

Metal Designs, Baskets, Wire Work & Novelties

and are dealers in

Glassware Decorative Greens and Florists' Requisites.

WHOLESALE FLOWER MARKETS. — PER 100. — TO DEALERS ONLY.

	CINCINNATI April 13	DETROIT April 20	BUFFALO April 22	PITTSBURG Ap 12
ROSES				
Am. Beauty, Fan, and Sp.	25.00 to 35.00	20.00 to 25.00	30.00 to 35.00	30.00 to 35.00
" Extra	15.00 to 25.00	15.00 to 20.00	20.00 to 30.00	20.00 to 25.00
" No. 1	10.00 to 15.00	10.00 to 15.00	8.00 to 10.00	10.00 to 15.00
" Lower grades	4.00 to 8.00	4.00 to 8.00 to 8.00	4.00 to 6.00
Bride, 'Maid, P. & S.	8.00 to 10.00	6.00 to 8.00	8.00 to 10.00 to 10.00
" Extra	6.00 to 8.00	4.00 to 6.00	6.00 to 8.00	6.00 to 8.00
" " Lower grades	3.00 to 4.00	3.00 to 4.00	3.00 to 6.00 to 4.00
Killarney, Richmond, Fan & Sp.	8.00 to 10.00	6.00 to 8.00	8.00 to 10.00	8.00 to 12.00
" " Lower grades	4.00 to 6.00	4.00 to 6.00	2.00 to 8.00	4.00 to 6.00
Chateau, Wellesley, Fan & Sp.	6.00 to 8.00	6.00 to 8.00	8.00 to 10.00	6.00 to 8.00
" " Lower grades	4.00 to 5.00	3.00 to 6.00	4.00 to 8.00 to 4.00
" Golde Gate, Ivory	4.00 to 6.00 to	4.00 to 6.00	4.00 to 6.00
CARNATIONS				
Fancy and Novelties to 3.00	1.50 to 2.00	2.00 to 3.00	2.00 to 3.00
Ordinary	1.00 to 2.00	1.00 to 1.50	1.50 to 2.00	1.00 to 1.50
MISCELLANEOUS				
Violets	.50 to .75	1.00 to 1.50	.50 to .75	.50 to .75
Cattleyas	40.00 to 50.00 to 50.00	60.00 to 75.00 to 75.00
Cypripediums to to to to
Lilies	10.00 to 12.50	12.50 to 15.00	8.00 to 12.00	8.00 to 12.00
Lily of the Valley	3.00 to 4.00	3.00 to 4.00	2.00 to 4.00	3.00 to 4.00
Daisies	1.00 to 2.00 to	1.00 to 2.00	1.00 to 2.00
Daffodils	2.00 to 3.00	2.00 to 3.00	2.00 to 3.00	1.00 to 3.00
Tulips	2.00 to 4.00	2.00 to 3.00	2.00 to 3.00	1.00 to 3.00
Mignonette to 4.00	2.00 to 4.00	2.00 to 4.00	2.00 to 4.00
Gardenias to 25.00 to	30.00 to 40.00 to
Lilac per bunch to 1.00	2.00 to 4.00	1.50 to 2.00 to 1.00
Sweet Peas	.50 to .75	1.00 to 2.00	.40 to .75	.50 to 1.00
Adiantum to 1.00	.75 to 1.00	.50 to 1.00 to 1.25
Whitcomb Fronds to to	8.00 to 10.00 to
Smilax	10.00 to 12.50	12.50 to 15.00 to 15.00	12.50 to 15.00
Asparagus Plumosus, strings	40.00 to 50.00	35.00 to 50.00	50.00 to 60.00 to 50.00
" " & Spren. (100 bchs.)	25.00 to 35.00	30.00 to 50.00	25.00 to 50.00	20.00 to 50.00

In writing to Advertisers kindly mention Horticulture

Buyer's Directory and Ready Reference Guide

Advertisements under this head, one cent a word. Initials count as words.

Regular advertisers in this issue are also listed under this classification without charge. Reference to List of Advertisers will indicate the respective pages.

Buyers failing to find what they want in this list will confer a favor by writing us and we will try to put them in communication with reliable dealers.

ACCOUNTANT

R. J. Dysart, 28 State St., Boston.
For page see List of Advertisers.

ALTERNANTHERAS

Red Alternantheras at 40 cents per 100.
C. W. Moeckel, 17 Summer St., Fitchburg, Mass.

ANEMONES

Henry A. Dreer, 714 Chestnut St., Phila.
For page see List of Advertisers.

AQUATIC PLANTS

Aquarium plants the year round. Wholesale and retail. Send for price list. Schmidt's Emporium of Pets, 712 12th Street, Washington, D. C.

ARAUCARIAS

Araucaria excelsa, 6-in., splendid stock, \$9.00 per doz. Holton & Hunkel Co., Milwaukee, Wis.

ASPARAGUS

A. N. Pierson, Cromwell, Conn.
Asparagus Plumosus Seedlings.
For page see List of Advertisers.

Asparagus plumosus and Sprengerl, 2-in., strong, \$2.00 per 100. J. H. Daun & Son, Westfield, N. Y.

150 Asparagus plumosus nanus, 2½-in., extra fine, 3c.; 300 Pteris Ouvrardi, 2½-in., 2c.; heliotropes, 2-in., 2c.; dahlia roots, best varieties, \$2.00 per 100; mixed, \$1.50. Edwin Bishop, Roslyn, Md.

Asparagus Plumosa, 2 in. pots. Fine plants, \$3.00 per 100; \$25.00 per 1000. Cash with order or good reference. Erie Floral Co., Erie, Pa.; or, Wm. F. Kasting Co., 385 Ellicott St., Buffalo, N. Y.

ASPARAGUS ROOTS

D. Landreth Seed Co., Bristol, Pa.
For page see List of Advertisers.

AUCTION SALES

Cleary's Horticultural Co., 62 Vesey St., New York.

For page see List of Advertisers.

Wm. Elliott & Sons, 201 Fulton St., New York.

For page see List of Advertisers.

AZALEAS

A. Leuthy & Co., Perkins St. Nurseries, Roslindale, Mass.

For page see List of Advertisers.

August Rolker & Sons, New York, 31 Barclay St., or P. O. Box 752.
For page see List of Advertisers.

Azalea amoena, young plants, \$5, \$10 and \$15 per 100. Fine plants full of buds, \$50 per 100; 2 1/2 to 3 ft., \$100 per 100. Ask for list of trees and shrubs in variety. Samuel C. Moon, Morrisville, Pa.

BAMBOO CANES

Stump & Walter Co., 50 Barclay St., New York.

For page see List of Advertisers.

Yokohama Nursery Co., 31 Barclay Street, New York.

For page see List of Advertisers.

BAY TREES.

N. F. McCarthy & Co., 84 Hawley St., Boston.

For page see List of Advertisers.

Bay Trees and Box Trees, standards and pyramids. All sizes. Price list on application. J. Roehrs Co., Rutherford, N. J.

BEDDING PLANTS

R. Vincent, Jr., & Sons Co., White Marsh, Maryland.

For page see List of Advertisers.

BEGONIAS

Thomas Roland, Nahant, Mass.

Gloire De Lorraine.

For page see List of Advertisers.

Begonia Pres. Carnot, 2 1/2 in., \$3.00 100. Valley Greenhouse Co., Sewickley, Pa.

BOILERS

BOILERS. "Burnham" Boilers made for greenhouse heating. Lord & Burnham, 1133 Broadway, N. Y.

BUILDERS' AND FARM LEVELS

Bostron-Brady Mfg. Co., 139 Madison Ave., Atlanta, Ga.

For page see List of Advertisers.

BUILDING MATERIAL

BUILDING MATERIAL of all description for All Cypress, Semi-Iron, Iron Frame or Truss Houses. Hot Bed Sash and Frames. Lord & Burnham Co., 1133 Broadway, N. Y.

BULBS AND TUBERS

Joseph Breck & Sons, 47-54 N. Market St., Boston.

For page see List of Advertisers.

J. M. Thorburn & Co., 33 Barclay St., New York.

For page see List of Advertisers.

A. T. Boddington, 342 W. 14th St., N. Y.

For page see List of Advertisers.

Rickards Bros., 37 East 19th St., New York.

For page see List of Advertisers.

H. F. Michell Co., Philadelphia.

For page see List of Advertisers.

H. E. Fiske Seed Co., Faneuil Hall Sq., Boston.

For page see List of Advertisers.

Jsmes Vick's Sons, Rochester, N. Y.

For page see List of Advertisers.

Aug. Rolker & Sons, 31 Barclay St., New York.

For page see List of Advertisers.

Seasonable Import Plants and Bulbs. For page see List of Advertisers.

K. Velthuis, Hillegom, Holland.

Represented by Felix Bosch, 260 Clarendon St., Boston.

Bulbs French and Dutch.

For page see List of Advertisers.

Ralph M. Ward & Co., 2 W. Broadway, New York, Agts. for Martial Bremond, Ollioules, France.

For page see List of Advertisers.

Stump & Walter Co., 50 Barclay St., N. Y.

For page see List of Advertisers.

V. H. Hallock & Son, Queens, N. Y.

For page see List of Advertisers.

Lilium Auratum and Double Begonia Bulbs.

CANNAS

The Conard & Jones Co., West Grove, Pa.

For page see List of Advertisers.

J. B. Shurtleff & Son, Cushman Ave., Revere, Mass.

For page see List of Advertisers.

Live Cannas Started from Sand.

For page see List of Advertisers.

CARNATIONS

F. Dorner & Sons Co., Lafayette, Ind.
For page see List of Advertisers.

S. S. Skidelsky, 1741 N. 18th St., Philadelphia.

For page see List of Advertisers.

Chicago Carnation Co., Joliet, Ill.

For page see List of Advertisers.

John E. Haines, Bethlehem, Pa.

Carnations Imperial and Pink Imperial.

For page see List of Advertisers.

Chas. H. Totty, Madison, N. J.

For page see List of Advertisers.

A. N. Pierson, Cromwell, Conn.

For page see List of Advertisers.

White Enchantress, unrooted cuttings. Write for prices. Wou first prize for best vase of 50. F. H. Westhoff, De Haven, Pa.

Carnation cuttings of all the leading varieties at the same price as any reliable firm. Write for prices before you look elsewhere. Wm. F. Kasting Co., 383 Ellicott St., Buffalo, N. Y.

CARNATIONS! FIELD GROWN!!

15,000 Enchantress and Winsor, ready for delivery July 1st. Orders filled in strict rotation. Order now and be first! Prices on application. We guarantee satisfaction. We lead in superb field grown stock.

WANOKA GREENHOUSES,

Barneveld, N. Y.

CHRYSANTHEMUMS

Chas. H. Totty, Madison, N. J.

Single Chrysanthemums.

For page see List of Advertisers.

A. N. Pierson, Cromwell, Conn.

For page see List of Advertisers.

Wm. W. Edgar Co., Waverley, Mass.

For page see List of Advertisers.

H. F. Littlefield, 532 Main St., Worcester, Mass.

For page see List of Advertisers.

Rooted Cuttings.

For page see List of Advertisers.

Dr. Enguehard, rooted cuttings, \$9.00 per 1000. Otto Bourdy, Lowell, Mass.

Chrysanthemum rooted cuttings, best varieties; write for list and prices. Edwin Bishop, Roslyn, Md.

Chrysanthemums. 5000 unrooted cuttings of Yellow Bonnafton, 70c. per 100. F. H. Westhoff, De Haven, Pa.

Have 100,000 fine young well-rooted Mums, cuttings of the best 60 commercial varieties. Send for our new and low price list. Satisfaction guaranteed. Wm. Ehmann, Jr., Corfu, N. Y.

Chrysanthemums ready: 2 1/2 inch strong stock of Touse, Oct. Frost, Polly Rose, Wanamaker, and all standards, \$3 per 100, \$25 per M. New: 2 1/2, strong, Alice Roosevelt, Hankey, Clay Frick, Winter Cheer, Rosette, B. May, \$5 per 100, \$40 per M. Cash. Send for catalog. Harloward Greenhouses, Greenport, N. Y.

COLEUS

Coleus Golden Bedder, Verschaffeltii, 2 in., \$2.00 100; rooted cuttings, 60c. 100. Valley Greenhouse Co., Sewickley, Pa.

Coleus, Golden Bedder, Verschaffeltii, and mixed Coleus, rooted cuttings, 60c. per 100; \$5.00 per 1000. Cash with order. J. E. Felthousen, Florist, Schenectady, N. Y.

CONIFERS

John Waterer & Sons, Ltd., American Nursery, Bagshot, Eng.

For page see List of Advertisers.

New England Nurseries, Bedford, Mass.

For List of Advertisers See Page 581

CUT FLOWER BOXES.

Edwards Folding Box Co., Philadelphia
For page see List of Advertisers.

Folding cut flower boxes, the best made
Write for list. Holton & Hunkel Co., Milwaukee, Wis.

CYCLAMEN.

Cyclamen seedlings, fine stock, \$1.50 per 100. Holton & Hunkel Co., Milwaukee, Wis.

DAHLIAS

David Herbert & Son, Atco, N. J.
For page see List of Advertisers.

J. L. Moore, Northboro, Mass.
For page see List of Advertisers.

15,000 Field-grown clumps 2c. and up. List ready. H. W. Koerner, Sta. B, Milwaukee, Wis.

Dahlia Bulbs, 25 choice named varieties, 1-3 Cactus, for \$1. Catalog free. C. Peirce, Dighton, Mass.

Dahlias: About 2000 Cath. Duer, Kreimhilde, Brunhilde, Snowlad, etc., \$3 per 100. Cash. Harlowarden Greenhouses, Greenport, N. Y.

Dahlias. Novelties and standard varieties, true to name, a choice list of the best introductions. Send for catalogue of dahlias, hollyhocks, hardy plants, etc. W. W. Wilmore, Box 382, Denver, Colo.

Dahlia Roots—Undivided field clumps, Lyndhurst, Maid of Kent, William Agnew, White Swan, Kreimhilde, John Walker, Arabella and A. D. Lyonl. Write for low prices. Wood & Healey, Hammonton, New Jersey.

The East Bridgewater Dahlia Gardens have 50 varieties of up-to-date dahlias to offer in full field clumps just as dug. Over 200,000 clumps. Send to the eastern dahlia king for rock bottom price list. J. K. Alexander, East Bridgewater, Mass.

Cactus, Decorative, Show, Fancy and Pompon Dahlias. 75 leading varieties to select from. Strong divided clumps, in 10 or 20 varieties, my selection at \$3.00 per 100; \$25.00 per 1000. Single Dahlias, mixed, \$1.00 per 100. Cash with order please. Hermann Thiemann, Mouson, Mass.

DECORATIVE PLANTS

A. Leuthy & Co., Perkins St. Nurseries, Roslindale, Mass.
For page see List of Advertisers.

EUONYMUS RADICANS

Euonymus radicans, 1-1 1/2 ft., \$6.00; 2-2 1/2 ft., \$8.00 per 100. Bushy plants. Brae-Burn Nursery, West Newton, Mass.

EVERGREENS

The New England Nurseries, Bedford, Mass.

Evergreens—Colorado spruce, 6 to 8 ft.; Norway spruce, 10 to 14 ft.; Eastern spruce 6 to 8 ft.; Nordmann's fir, 4 to 6 ft., also 1 to 2 ft. Small evergreens for nursery planting, in great variety. Ask for list. Samuel C. Moon, Morrisville, Pa.

FERNS

A. Leuthy & Co., Roslindale, Mass.
For page see List of Advertisers.

H. H. Barrows & Son, Whitman, Mass
Nephrolepis Whitman.
For page see List of Advertisers.

John Scott, Brooklyn, N. Y.
For page see List of Advertisers.

Baur Floral Co., Erie, Pa.

Nephrolepis Exaltata Bostoniensis, fine young plants, \$10.00 per 1000.

N. Elegantissima, young plants \$15.00 per 1000. Send for price list. Soar Broa. Little River, Fla.

FERTILIZERS

Pulverized Manure Co., 31 Union Stock Yards, Chicago, Ill.

Wizard Brand Cattle Manure.
For page see List of Advertisers.

Thos. J. Grey & Co.,
82 and 33 South Market St., Boston.

High-Grade Scotch Soot.
For page see List of Advertisers.

FIGUS

Ficus elastica, 5-in., extra fine stock, \$4.00 per doz. Holton & Hunkel Co., Milwaukee, Wis.

FLORAL PHOTOGRAPHS

Floral Photographs. Foley's 226-228 1/2 Bowery, New York.

FLORISTS' LETTERS.

Boston Florist Letter Co., 66 Pearl St., Boston, Mass.

For page see List of Advertisers.

Koral Mfg. Co., 26 Hawley St., Boston.
For page see List of Advertisers.

FLORISTS SUPPLIES

N. F. McCarthy & Co., 84 Hawley St., Boston.

For page see List of Advertisers.

H. M. Robinson & Co., 15 Province St. and 9 Chapman Pl., Boston, Mass.
For page see List of Advertisers.

The Keivan Co., 113 W. 28th St., N. Y.
Decorative Evergreens.
For page see List of Advertisers.

Reed & Keller, 122 W. 25th St., New York.
For page see List of Advertisers.

J. B. Murdoch & Co., 714 Penn Ave., Pittsburg, Pa.

For page see List of Advertisers.

H. Bayersdorfer & Co., 1129 Arch St., Philadelphia.

For page see List of Advertisers.

Alex. Maun, Jr., Co., 1125 Poik St., San Francisco, Calif.

For page see List of Advertisers.

FLOWERS BY TELEGRAPH

Park Floral Co., Denver, Colo.
For page see List of Advertisers.

J. N. Champlin & Co., 1026 Chapel St., New Haven, Conn.
For page see List of Advertisers.

George H. Cooke, Washington, D. C.
For page see List of Advertisers.

Gude Bros. Co., 1214 F St., Washington, D. C.

For page see List of Advertisers.

Atlanta Floral Co., Atlanta, Ga.
For page see List of Advertisers.

M. C. & J. E. Hauswirth, 232 Michigan Ave., Chicago.
For page see List of Advertisers.

William J. Smyth, Michigan Ave. and 31st St., Chicago.
For page see List of Advertisers.

George Withhold Co., 1657-59 Buckingham Place, Chicago.
For page see List of Advertisers.

Jacob Schulz, 644 4th Ave., Louisville, Ky.
For page see List of Advertisers.

Thos F. Galvin, 124 Tremont St., Boston.
For page see List of Advertisers.

Julius A. Zinn, 2 Beacon St., Boston.
For page see List of Advertisers.

Houghton & Clark, 396 Boylston St., Boston.
For page see List of Advertisers.

Sidney Hoffman, 59-61 Massachusetts Ave., Boston.
For page see List of Advertisers.

Edward MacMullin, 194 Boylston St., Boston.
For page see List of Advertisers.

J. Breitmeyer's Sons, Miami and Gratiot Aves., Detroit, Mich.
For page see List of Advertisers.

Samuel Murray, 1017 Broadway, Kansas City, Mo.

For page see List of Advertisers.

Wm. L. Rock Flower Co., 1116 Walnut St., Kansas City, Mo.
For page see List of Advertisers.

Fred C. Weber, 4328-28 Olive St., St. Louis, Mo.

For page see List of Advertisers.

H. G. Eyres, 11 N. Pearl St., Albany, N.Y.
For page see List of Advertisers.

FLOWERS BY TELEGRAPH —

Continued

David Clarke's Sons, 2159-2141 Broadway, New York.

For page see List of Advertisers.

W. H. Donohoe, 17 E. 28th St., New York.
For page see List of Advertisers.

Alex. McConnell, New York.
For page see List of Advertisers.

M. A. Bowe, 1294 Broadway, New York.
For page see List of Advertisers.

Robert G. Wilson, Fulton St. & Greene Av., Brooklyn, N. Y.
For page see List of Advertisers.

Thomas Young, Jr., 500 Fifth Ave., N. Y.
For page see List of Advertisers.

Young & Nugent, 42 W. 28th St., N. Y.
For page see List of Advertisers.

J. H. Dunlop, 96 Yonge St., Toronto, Can.
For page see List of Advertisers.

FLOWER POTS

W. H. Ernest, 28th and M Sta., Washington, D. C.

For page see List of Advertisers.

A. H. Hews & Co., Cambridge, Mass.
For page see List of Advertisers.

Hilfinger Bros., Ft. Edward, N. Y.
For page see List of Advertisers.

Red pots, seed pans, etc.
The Peters & Reed Pottery Co., Zanesville, O.

FORESTRY AND ORNAMENTAL PLANTING

Jackson's Nurseries, Portland, Me.
For page see List of Advertisers.

FUCHSIAS

Fuchsias, finest mixed, 2 in., \$2.50 per 100; rooted cuttings, \$1.00. Valley Greenhouse Co., Sewickley, Pa.

GALAX

Michigan Cut Flower Co., 38 and 40 Broadway, Detroit, Mich.

For page see List of Advertisers.

GERANIUMS

R. Vincent Jr. & Sons Co., White Marsh, Md.

New and Standard Varieties.
For page see List of Advertisers.

Wm. W. Edgar Co., Waverley, Mass.
For page see List of Advertisers.

Geraniums, 2-in., double red, \$2.00 per 100. J. H. Dann & Son, Westfield, N. Y.

Geraniums Nutt, Doyle, Castellane, Perkins, La Favorite, Mme. Sallerol, 2-in., \$2.50 per 100; my selection, \$2.00 per 100. Fleur Blanc, the new white, 75c. doz.; \$1.00 per 100; A. H. Trego, 50c. doz.; \$3.50 per 100. William Doel, Pascoag, R. I.

GLADIOLI

Arthur Cowee, Meadowvale Farm, Berlin, New York.

For page see List of Advertisers.

J. L. Moore, Northboro, Mass.
For page see List of Advertisers.

I. & J. L. Leonard, Iona, N. J.
Gladiolus Bulbs.
For page see List of Advertisers.

Gladiol. Write for leaflet. B. Hammond Tracy, Cedar Acres, Wenham, Mass.

Gladiolus Bulbs and hand hybridized seed. Newest. Best. Circular free. B. F. White, Terryville, Conn.

GLASS

Boston Plate & Window Glass Co., Boston.
For page see List of Advertisers.

Standard Plate Glass Co., 26-30 Sudbury St., Boston.

For page see List of Advertisers.

Metropolitan Material Co., 1398-1408 Metropolitan Ave., Brooklyn, N. Y.
For page see List of Advertisers.

S. Jacobs & Sons, 1365-79 Flushing Ave., Brooklyn, N. Y.

In writing to Advertisers kindly mention Horticulture

GLASS - Continued

Foley Mfg. Co., Western Ave., between 25th & 26th Sts., Chicago.

Greenhouse glass, lowest prices. Johnston Glass Co., Hartford City, Ind.

GLASS, High Grade, Double Thick Greenhouse Glass. Lord & Burnham, 1133 Broadway, N. Y.

GLAZING POINT

H. A. Dreer, Philadelphia, Pa.
For page see List of Advertisers.

GLAZING POINTS, Lord & Burnham Special Glazing Nails (Points). Lord & Burnham, 1133 Broadway, N. Y.

GREENHOUSE BUILDING MATERIAL

Lord & Burnham Co.,
1133 Broadway, New York.

For page see List of Advertisers.

Pierson U-Bar Co., 1 Madison Sq., N. Y.
For page see List of Advertisers.

A. T. Stearns Lumber Co., Neponset, Boston.

For page see List of Advertisers.

Klug Construction Co., N. Tonawanda, New York.

For page see List of Advertisers.

J. C. Moulting Co., 117 East Blackhawk St., Chicago, Ill.

For page see List of Advertisers.

Foley Mfg. Co., Western Ave., between 25th & 26th Sts., Chicago.

For page see List of Advertisers.

I. Cassidy, Summer Ave. and Erie R. R., Newark, N. J.

For page see List of Advertisers.

Metropolitan Material Co., 1398-1408 Metropolitan Ave., Brooklyn, N. Y.

For page see List of Advertisers.

Geo. B. Doane, 18 Midway St., Boston, Iron Pipe.

For page see List of Advertisers.

W. H. Lutton, Jersey City, N. J.

S. Jacobs & Sons, 1365-79 Flushing Ave., Brooklyn, N. Y.

GREENHOUSE CONSTRUCTION

GREENHOUSE CONSTRUCTION, Semi-Iron Greenhouse, New Truss Houses and Iron Frame Houses. Lord & Burnham, 1133 Broadway, N. Y.

J. A. Payne, 260-274 Culver Ave., Jersey City, N. J.

For page see List of Advertisers.

I. Cassidy, Summer Ave. and Erie R. R., Newark, N. J.

For page see List of Advertisers.

Foley Mfg. Co., Western Ave., between 25th & 26th Sts., Chicago.

For page see List of Advertisers.

W. H. Lutton, Jersey City, N. J.

GUTTERS

GUTTERS, Cast Iron Gutters, L. & B. Improved V Shaped Gutter with drip gutter attachment. Lord & Burnham, 1133 Broadway, N. Y.

HAIL INSURANCE

Florists' Hall Assn. of America.

J. G. Esler, Saddle River, N. J.

For page see List of Advertisers.

HARDY FERNS AND SUPPLIES

H. M. Robinson & Co., 15 Province St. and 8 Chapman Pl., Boston, Mass.
For page see List of Advertisers.

The Kervan Co., 113 W. 28th St., N. Y.
For page see List of Advertisers.

Michigan Cut Flower Exchange,
88 and 49 Broadway, Detroit, Mich.
Fanny Ferns.

For page see List of Advertisers.

H. J. Smith, Illsdale, Mass.

HARDY PLANTS

Lobelia cardinalis, large clumps, \$1.50 per doz., \$8.00 per 100. Gentiana Andrewsii and linearis, in clumps, \$1.50 per doz., \$8.00 per 100. Native ferns, trees and shrubs at prices to suit. A fine lot of nursery grown White Pine, Hemlock, Fir Balsam, Norway and White Spruce of various sizes at reduced prices. L. E. Williams, Nottingham, N. H.

HART'S HANDY HANDLE

Geo. B. Hart, 24 Stone St., Rochester, N. Y.
For page see List of Advertisers.

HEATING APPARATUS

Lord & Burnham Co.,
1133 Broadway, New York.

For page see List of Advertisers.

Pierson U-Bar Co., 1 Madison Sq., N. Y.
For page see List of Advertisers.

John A. Payne, 260-274 Culver Ave., Jersey City, N. J.

For page see List of Advertisers.

HELIOTROPES.

Heliotropes, 2-in., 2c.; rooted cuttings, from soil, 75c. per 100. Edwin Bishop, Roslyn, Md.

Heliotropes, 2 in., \$2.50 100; rooted cuttings, \$1.00 100. Valley Greenhouse Co., Sewickley, Pa.

HELP FURNISHED

Thos. H. Bumbleck, 34 S. 7th St., Phila.

For page see List of Advertisers.

HERBACEOUS PERENNIALS

Red Oak Nurseries, Flskeville, R. I.

For page see List of Advertisers.

HOLLYHOCKS

Hollyhocks, separate colors, field grown, healthy stock, \$3.00 per 100; also Dahlias, novelties and standard varieties. Send for catalogue. W. W. Wilmore, Box 382, Denver, Colo.

HOSE

Frank L. Moore, Chatham, N. J.

Sunnyside Hose.

For page see List of Advertisers.

HOT-BED SASH

The A. T. Stearns Lumber Co., Neponset, Mass.

For page see List of Advertisers.

Pierson U-Bar Co., 1 Madison Sq., N. Y.

For page see List of Advertisers.

Lord & Burnham Co., 1133 Broadway, N. Y.
For page see List of Advertisers.

Foley Mfg. Co., Western Ave., between 25th & 26th Sts., Chicago.

HYDRANGEAS.

HYDRANGEAS PANICULATA.

Grandiflora, 18-in. to 24-in., \$5.00 per 100.
Grandiflora, 2 ft. to 3 ft., \$7.00 per 100.
Grandiflora, 3 ft., \$8.00 per 100.

J. H. Dann & Son, Westfield, N. Y.

INSECTICIDES.

Nicotinide kills all greenhouse pests

P. R. Palethorpe Co.,
Eleventh St., Owensboro, Ky.

For page see List of Advertisers.

IRISES

J. M. Thorburn & Co., 33 Barclay St.,
New York.

For page see List of Advertisers.

Henry A. Dreer, 714 Chestnut St., Phila.
For page see List of Advertisers.

Japan Iris (Iris Kaempferi), divided roots, 2-5 shoots, mixed, \$4.00 per 100; divided roots, 2-5 shoots, white, \$5.00 per 100. Large clumps, 10c. each. Wm. F. Halsey, Southampton, N. Y.

KENTIAS

A. Lenth & Co., Roslindale, Mass.

For page see List of Advertisers.

LAWN VASES

Kramer Bros. Fdy. Co., Dayton, Ohio.

For page see List of Advertisers.

LEADING RETAIL FLORISTS

Park Floral Co., Denver, Colo.

For page see List of Advertisers.

George H. Cooke, Washington, D. C.

For page see List of Advertisers.

Gude Bros. Co., 1214 F St.,
Washington, D. C.

For page see List of Advertisers.

Atlanta Floral Co., Atlanta, Ga.

For page see List of Advertisers.

M. C. & J. E. Hauswirth, 222 Michigan Ave.,
Chicago.

For page see List of Advertisers.

LEADING RETAIL FLORISTS -**Continued**

William J. Smyth, Michigan Ave. and 31st St., Chicago.

For page see List of Advertisers.

George Witthold Co., 1657-59 Buckingham Place, Chicago.

For page see List of Advertisers.

Jacob Schulz, 644 4th Ave., Louisville, Ky.
For page see List of Advertisers.

Thos. F. Galvia, 124 Tremont St., Boston.
For page see List of Advertisers.

Julius A. Zinn, 2 Beacon St., Boston.

For page see List of Advertisers.

Houghton & Clark, 396 Boylston St.,
Boston.

For page see List of Advertisers.

Sidney Hoffman, 59-61 Massachusetts Ave.,
Boston.

For page see List of Advertisers.

Edward MacMinkin, 194 Boylston St.,
Boston.

For page see List of Advertisers.

J. Brettmeyer's Sons, Detroit, Mich.

For page see List of Advertisers.

Samuel Murray, 1017 Broadway,
Kansas City, Mo.

For page see List of Advertisers.

Wm. L. Rock Flower Co., 1118 Walnut St.,
Kansas City, Mo.

For page see List of Advertisers.

Fred C. Weber, 4326 Olive St., St. Louis,
Mo.

For page see List of Advertisers.

J. N. Champlin & Co., 1026 Chapel St.,
New Haven, Conn.

For page see List of Advertisers.

H. G. Eyres, 11 N. Pearl St., Albany, N. Y.
For page see List of Advertisers.

David Clarke's Sons, 2139-2141 Broadway,
New York.

For page see List of Advertisers.

W. H. Donohoe, 17 E. 28th St., New York.
For page see List of Advertisers.

Alex. McConnell, New York.

For page see List of Advertisers.

M. A. Bove, 1234 Broadway, New York.
For page see List of Advertisers.

Robert G. Wilson, Fulton St. and Greene
Ave., Brooklyn, N. Y.

For page see List of Advertisers.

Thomas Young, Jr., 500 Fifth Ave., N. Y.
For page see List of Advertisers.

Young & Nugent, 42 W. 28th St., N. Y.
For page see List of Advertisers.

J. H. Dunlop, 96 Yonge St., Toronto, Can.
For page see List of Advertisers.

LILIES

Miami Floral Co., Dayton, O.

For page see List of Advertisers.

MASTICA

F. O. Pierce Co., 12 W. Broadway,
New York.

For page see List of Advertisers.

MOON VINES

Godfrey Aschmann, 1012 W. Ontario St.,
Philadelphia.

For page see List of Advertisers.

Moon vines, fine strong plants, 3 in.,
\$4.00 per 100. Edwin Bishop, Roslyn, Md.

For page see List of Advertisers.

NEW AND RARE PLANTS

Rose Hill Nurseries, New Rochelle, N. Y.

For page see List of Advertisers.

NICO-FUME

Kentucky Tobacco Product Co.,
Louisville, Ky.

For page see List of Advertisers.

NURSERY STOCK

John Waterer & Sons, Ltd.,
American Nursery, Bagshot, England.

For page see List of Advertisers.

New England Nurseries, Bedford, Mass.
Shrubs, Roses and Herbaceous Perennials.

Specimen Pyramidal Box.

For page see List of Advertisers.

Ray State Nurseries, N. Abington, Mass.
Herbaceous Perennials, Hardy Ornamental
Trees.

For page see List of Advertisers.

For List of Advertisers See Page 581

NURSERY STOCK—Continued
 Cleary's Horticultural Co., 62 Vesey St., New York.
 For page see List of Advertisers.
 P. Ouwerkerk, 216 Jane St., Weehawken Heights, N. J.
 Holland Nursery Stock for Forcing.
 For page see List of Advertisers.
 American Nursery Co., 150 Broadway, New York, N. Y.
 For page see List of Advertisers.
 I. & J. L. Leonard, Iona, N. J.
 California Privet, American Chestnuts.
 For page see List of Advertisers.

The Morris Nursery Co., Sales Office, 1 Madison Ave., New York.
 Ornamental Trees, Evergreens, Hedge Plants.
 For page see List of Advertisers.
 Peter's Nursery Co., Knoxville, Tenn.
 Live Fences; Amoor and California Privet.
 For page see List of Advertisers.

Nursery Stock—Berberis Thunbergii 1 yr. seedlings, \$10 per 1000; 2 yrs., \$15 per 1000. Viburnum plicatum, \$50, \$60 and \$80, per 1000. Ligustrum Ibofa, 4 ft., \$9 per 100. Rosa Wichurana, 4 to 6 ft. Loncera Morrowii, 3 to 4 ft. Bignonia Thunbergii and radicans. Send for list of shrubs, large and small. Samuel C. Moon, Morrisville, Pa.

ORCHID PLANTS

Lager & Hurrell, Summit, N. J.
 For page see List of Advertisers.
 Sauder, St. Albans, England.
 Importers, Exporters, Growers, Hybridists
 For page see List of Advertisers.
 Julius Roehrs Co., Rutherford, N. J.
 For page see List of Advertisers.
 Csrillo & Baldwin, Secaucus, N. J.
 For page see List of Advertisers.
 Jos. A. Manda, 191 Valley Road, W. Orange, N. J.
 For page see List of Advertisers.
 Ordonez Bros., Madison, N. J., Box 106
 For page see List of Advertisers.

PALMS

A. Leuthy & Co., Perkins St. Nurseries Roslindale, Mass.
 For page see List of Advertisers.
 Robert Craig Co., Market and 49th Sts., Philadelphia, Pa.
 For page see List of Advertisers.
 Kentla, Phoenix, etc., all sizes. Write for new price list. Julius Roehrs Co., Rutherford, N. J.

PAINT AND PUTTY

PAINT AND PUTTY: Ideal Greenhouse lead; Special Greenhouse Putty. Lord & Burnham, 1133 Broadway, N. Y.

PATENTS

Siggers & Siggers, Washington, D. C.
 For page see List of Advertisers.

PEAT

Orchid peat, Rotted peat, Azalea peat, Leaf-Mould, Live Sphagnum moss, Baled Sphagnum moss, Green Clump moss, etc. Jobbers' list on application. C. W. Brownell & Co., Walden, N. Y.

PELARGONIUMS

R. Vincent, Jr. & Sons Co., White Marsh, Maryland.
 For page see List of Advertisers.

PEONIES

Wholesale Peony list for fall 1908 is now ready. J. F. Rosenfield, West Point, Neb.
 One of the finest collections in America. Send 25 cts. in stamps for new edition of Peony Manual. C. S. Harrison's Select Nursery, York, Neb.

PHLOXES

Henry A. Dreer, 714 Chestnut St., Phila.
 For page see List of Advertisers.
 Send 25 cts. in stamps for Phlox Manual. Fine mixed phloxes \$1.50 per 100. C. S. Harrison's Select Nursery, York, Neb.

PIPE AND FITTINGS

Foley Mfg. Co., between Western Ave. and 26th St., Chicago, Ill.
 Eagle Metal & Supply Co., Johnson and Union Aves., Brooklyn, N. Y.
 Second-Hand Pipe and Boiler Tubes.
 For page see List of Advertisers.
 PIPE AND FITTINGS. Cast Iron and Wrought Pipe, Valves, Elbows, Pipe Hooks, Automatic Air Headers, etc. Lord & Burnham, 1133 Broadway, N. Y.

PLANT STAKES AND TRELLISES
 Seele's Patent, for roses, chrysanthemums, gladioli, tuberoses, dahlias tomatoes, egg plants, etc. H. D. Seele & Sons, Manuf., Elkhart, Ind.

POT HANGERS

Pot hangers, Kramer's \$1 doz. by exp., \$1.25 by mail. I. N. Kramer & Son, Cedar Rapids, Ia.

PRIMULAS

Primula obconica, famous Rousdorff & Lattmann strains. Large flowering blue, blood red, 40c. 1-2; 75c. tr. pkt. Carmine, lilac, dark eyed, rose, white, mixed, fringed lilac, white, mixed, 30c. 1-2; 50c. tr. pkt. P. Obe. Gigantea, originator's strain; Lilac, rose, mixed, 40c. 1-2; 75c. tr. pkt. Carmine, 40c. red, 25c. pkt. Primula chinensis, from the best specialist. Fringed blue, double mixed, 60c. 1-2; \$1.00 tr. pkt. Blood red, carmine, mottled, rose, striped, white, mixed, 40c. 1-2; 75c. tr. pkt. J. L. Schiller, 329 Fronty Av., Toledo, O.

PRIVET

1000 Ligustrum Ibofa, 4 ft.; 500 Ligustrum vulgaris, 2 to 4 ft.; 1000 Ligustrum chinensis, 3 ft., light, \$10 per 1000. Send for list of large and small shrubs. Samuel C. Moon, Morrisville, Pa.

RAFFIA

Raffia (colored), 20 beautiful shades Samples free. R. H. Coney Co., Camden, N. J.; 810 Washburn Ave., Chicago, Ill.

RHODODENDRONS

John Waterer & Sons, Ltd., American Nursery, Bagshot, England
 For page see List of Advertisers.
 P. Ouwerkerk, Hoboken, N. J.
 For page see List of Advertisers.
 New England Nurseries, Bedford, Mass.
 For page see List of Advertisers.

ROSES

Julius Roehrs Co., Rutherford, N. J.
 Rambler Rose, Newport Flisy.
 For page see List of Advertisers.
 New England Nurseries, Inc., Bedford, Mass.
 For page see List of Advertisers.
 Bay State Nurseries, N. Abington, Mass.
 For page see List of Advertisers.
 Robert Craig Co., Market and 49th Sts., Philadelphia, Pa.
 For page see List of Advertisers.
 Dingle-Conard Co., West Grove, Pa.
 New Climbing Rose, Tausendschon.
 For page see List of Advertisers.
 The Morris Nursery Co., Sales Office, 1 Madison Ave., New York.
 Ornamental Trees, Evergreens, Hedge Plants.
 For page see List of Advertisers.
 F. R. Pierson Co., Tarrytown-on-Hudson, N. Y.
 Hardy Roses for the Garden.
 For page see List of Advertisers.
 R. & J. Farquhar & Co., 6 and 7 South Market Street, Boston.
 For page see List of Advertisers.
 The E. G. Hill Co., Richmond, Ind.
 Roses, Rhea Reid, American Beauty.
 For page see List of Advertisers.
 Pochmann Bros. Co., Morton Grove, Ill.
 Roses That Win.
 For page see List of Advertisers.
 400 varieties; own roots; summer grown. Liddle Company, Springfield, Ohio.
 Roses, Maid, Bride, Chateaux, Gate, 2 in., \$3.00 100. Valley Greenhouse Co., Se wickety, Pa.
 Crimson Ramblers, 2 year, on own roots, extra strong, at 7 cents. Gilbert Costich, Rochester, N. Y.
 Low-budded roses, No. 1, \$95 00; No 1-2 \$65.00 1000. H. T. Jones, Elizabeth, N. J.

S. A. F. CONVENTION ACCOMMODATIONS

Tower Hotel, Niagara Falls, N. Y.
 For page see List of Advertisers.

SAGE PLANTS

Good thrifty sage plants from 2-luch pots, \$1.50 per 100; ready now. Cash with order. Virginia Nursery Co., Purcellville Va.

SEEDS

T. J. Grey Co., 32 So. Market St., Boston, Mass.
 For page see List of Advertisers.
 Joseph Breck & Sons, 51 and 52 N. Market St., Boston, Mass.
 For page see List of Advertisers.
 W. Atlee Burpee & Co., Philadelphia.
 For page see List of Advertisers.
 J. M. Thorburn & Co., 33 Barclay St., N. Y.
 For page see List of Advertisers.
 A. T. Boddington, 342 W. 14th St., N. Y.
 Giant Primula Seed.
 For page see List of Advertisers.
 H. F. Mitchell Co., 1017 Market St., Phila.
 For page see List of Advertisers.
 James Vick's Sons, Rochester, N. Y.
 Vick's Superb Pansy Seed.
 For page see List of Advertisers.
 Hjalmar Hartmann & Co., 12 Stormgade, Copenhagen, Denmark.
 Cauliflower and Cabbage Seed.
 For page see List of Advertisers.
 Rickards Bros., 37 E. 19th St., New York.
 For page see List of Advertisers.
 R. & J. Farquhar & Co., 67 So. Market St., Boston.
 For page see List of Advertisers.
 C. C. Morse & Co., 48-56 Jackson St., San Francisco, Cal.
 For page see List of Advertisers.
 H. E. Fiske Seed Co., Faneuil Hall Sq., Boston.
 Primula Fringed Sinensis.
 For page see List of Advertisers.
 Brasian Seed Growers Co., San Jose, Cal.
 For page see List of Advertisers.
 O. V. Zangen, Hoboken, N. J.
 For page see List of Advertisers.
 Stumpp & Walter Co., 50 Barclay St., New York.
 For page see List of Advertisers.
 Weeber & Don, 114 Chambers St., New York.
 For page see List of Advertisers.
 Altimo Culture Co., Canfield, O.
 Aster Seed.
 For page see List of Advertisers.
 Bloomsdale Seed Farms, Bristol, Pa.
 Onion Seed.
 For page see List of Advertisers.
 Asparagus Pl. Naanus, \$2.50 per 1000. Plant early. Asparagus Plants 14 to 18 inches high, \$6 per 100. Peter Mck, Box 172, Orlando, Fla.
 Davis Perfect and Burrell's Klondike Cucumber Seed, 85c. per pound. Finest slicing varieties grown. D. V. Burrell, Rocky Ford, Colorado.
SEEDS SEEDS SEEDS
 Buckbee's Famous "Full of Life" Pedigreed Strains of the newest and best varieties vegetable and flower seeds, etc. If you have failed to receive a copy of our Spring Trade List write for it today.
 H. W. BUCKBEE,
 Rockford, Illinois, Rockford Seed Farms, Forest City Greenhouses.
ASTER SEEDS. All full weight packets fertile 1907 crop. Express—White, Violet, Rose. Trade pkt., 1-16 oz., 25c.; 1-4 oz., 75c.; ounce, \$2.50. Queen of Market—White, Light Pink, Rose, Lavender, Purple. Trade pkt., 1-8 oz., 10c.; 1-4 oz., 15c.; ounce, 50c. Late Branching—White, Pink, Rose, Lavender, Purple. Trade pkt., 1-8 oz., 20c.; 1-4 oz., 30c.; ounce, 80c. Carlson's Branching—Pink, Lavender, Early and Late White. Trade pkt., 1-8 oz., 25c.; 1-4 oz., 40c.; ounce, \$1.25. Kate Lock White, Daybreak. Same price as Branching. Royal Purple—Trade pkt., 1-16 oz., 35c.; 1-4 oz., \$1.00; ounce, \$3.00. Violet King—Trade pkt., 1-8 oz., 20c.; 1-4 oz., 50c.; ounce, \$1.50. Many other standard sorts in limited quantity. Write if interested. Elmer D. Smith & Co., Adrian, Mich.

In writing to Advertisers kindly mention Horticulture

SMILAX

Smilax, choice young plants from fall; \$3.00 per 1000, 2000 for \$5.00, 5000 for \$10.00; 50c per 100 by mail. F. A. Baller, Bloomington, Ill.

SPHAGNUM MOSS

Live Sphagnum moss, orchid peat and orchid baskets always on hand. Lager & Hurrell, Summit, N. J.

Fresh, clean, 5 bbl. bale, \$1.25; 2 bales, \$2.25; 5 bales, \$5.00; 10 bales, \$9.50. Cash. H. R. Akers, Chatsworth, N. J.

SPRAYERS

Charles J. Jager Co., 281-85 Franklin St., Boston.

For page see List of Advertisers.

STOCKS

Strong Ten Week Stocks, colored, best German strain, out of 2 1/2 in. pots, just right for Memorial Day, at \$2.00 per 100, \$18.00 per 1000. C. W. Moeckel, 17 Summer St., Fitchburg, Mass.

STRAWBERRY PLANTS

C. S. Pratt, Reading, Mass. The Irish.

For page see List of Advertisers.

Strawberry plants and Asparagus roots (50 varieties). Catalog free. C. Peirce, Dighton, Mass.

STEAM TRAP

E. Hippar, Youngstown, O.

For page see List of Advertisers.

TRITOMAS

Henry A. Dreer, 714 Chestnut St., Phila. For page see List of Advertisers.

TO-BAK-INE

E. H. Hunt, Genl. Agt., 76-78 Wabash Av., Chicago.

For page see List of Advertisers.

VENTILATING APPARATUS

Pierson U-Bar Co., 1 Madison Sq., N. Y. For page see List of Advertisers.

Foley Mfg. Co., Western Ave., between 25th & 26th Sts., Chicago. For page see List of Advertisers.

John A. Payne, 250-274 Culver Ave., Jersey City, N. J.

For page see List of Advertisers.

The Advance Co., Richmond, Ind. For page see List of Advertisers.

Quaker City Machine Co., Richmond, Ind. 20th Century Ventilating App. For page see List of Advertisers.

VENTILATING MACHINERY. New Model enclosed, self-oiling gear; Standard Model Open Gear. Lord & Barnham, 1133 Broadway, N. Y.

VIOLETS

William Sim, Cliffdale, Mass.

Violet Boston.

For page see List of Advertisers.

Violet cuttings, "Maria Louisa" Rhinebeck stock, rooted runners, May delivery \$20.00 M. Wm. F. Kasting Co., 383 Ellcott St., Buffalo, N. Y.

WEEKLY BOARD FILE

A. F. Lewis Mfg. Co., E. Boston, Mass.

For page see List of Advertisers.

WIREWORK

Reed & Keller, 122 W. 25th St., N. Y.

For page see List of Advertisers.

Wirework. Write for our catalogue. Holton & Hunkel Co., Milwaukee, Wis.

William E. Hellscher's Wire Works, 28-40 Broadway, Detroit, Mich.

The "Just Right" kind. Send for price list. Frank W. Ball, 31 East Third Street, Cincinnati, O.

WHOLESALE FLORISTS**Boston**

N. F. McCarthy & Co., 84 Hawley St., Boston.

For page see List of Advertisers.

H. M. Robinson & Co., 15 Province St. and 9 Chapman Pl., Boston.

For page see List of Advertisers.

Welch Bros., 226 Devonshire St., Boston.

For page see List of Advertisers.

Buffalo

Wm. F. Kasting Co., 383-87 Ellcott St., Buffalo, N. Y.

For page see List of Advertisers.

WHOLESALE FLORISTS--**Continued****Chicago**

Chas. W. McKellar, 51 Wabash Ave., Chicago.

For page see List of Advertisers.

Peter Reinberg, 51 Wabash Ave., Chicago.

For page see List of Advertisers.

E. F. Winterson Co., 45-49 Wabash Ave., Chicago.

For page see List of Advertisers.

J. A. Budlong, 37-39 Randolph St., Chicago.

For page see List of Advertisers.

Detroit

Michigan Cut Flower Exchange, 38 and 40 Broadway, Detroit, Mich.

For page see List of Advertisers.

Minneapolis

Rice Bros., 115 N. 6th St., Minneapolis, Minn.

For page see List of Advertisers.

New York

J. K. Allen, 106 W. 25th St., New York

For page see List of Advertisers.

J. S. Feurich, 110 W. 25th St., New York

For page see List of Advertisers.

Ford Bros., 48 W. 25th St., New York

For page see List of Advertisers.

H. E. Froment, 57 W. 25th St., New York

For page see List of Advertisers.

Alex. J. Guttman, 43 W. 25th St., New York.

For page see List of Advertisers.

E. C. Horan, 55 W. 25th St., New York

For page see List of Advertisers.

A. H. Langjahr, 55 W. 25th St., New York.

For page see List of Advertisers.

James McManus, 42 W. 25th St., New York

For page see List of Advertisers.

John I. Raynor, 49 W. 25th St., New York

For page see List of Advertisers.

W. F. Sheridan, 39 W. 25th St., New York

For page see List of Advertisers.

Traendly & Schenck, 44 W. 25th St., New York.

For page see List of Advertisers.

John Young, 51 W. 25th St., New York

For page see List of Advertisers.

Moore, Heutz & Nash, 55 and 57 W. 26th St., New York.

For page see List of Advertisers.

Frank S. Hicks & Co., 52 W. 25th St., New York.

For page see List of Advertisers.

Frank Millang, 57 W. 26th St., New York

For page see List of Advertisers.

Wm. H. Kuebler, 28 Willoughby St., Brooklyn, N. Y.

For page see List of Advertisers.

Phillip F. Kessler, 55 and 57 W. 26th St., New York.

For page see List of Advertisers.

A. Moltz, 55-57 W. 26th St., New York.

For page see List of Advertisers.

B. S. Shinn, Jr., 55 W. 26th St., New York.

For page see List of Advertisers.

Millang Bros., 41 W. 25th St., New York.

For page see List of Advertisers.

Philadelphia

W. E. McKissick, 1619-1621 Ranstead St., Philadelphia, Pa.

For page see List of Advertisers.

Leo Niessen Co., 1200 Arch St., Philadelphia, Pa.

For page see List of Advertisers.

The S. S. Pennock-Meehan Co., 1608-18 Ludlow St., Philadelphia, Pa.

For page see List of Advertisers.

Edward Reid, 1528 Ranstead St., Philadelphia, Pa.

For page see List of Advertisers.

Pittsburg

J. B. Murdoch & Co., 714 Penn Ave., Pittsburg, Pa.

For page see List of Advertisers.

San Francisco

Alex. Maun, Jr., Co., 1125 Polk St., San Francisco, Cal.

For page see List of Advertisers.

St. Louis

H. G. Berning, 1402 Pine St., St. Louis, Mo.

For page see List of Advertisers.

WHOLESALE PLANTSMAN

Samuel A. Woodrow, 53 W. 30th St., New York.

For page see List of Advertisers.

WILD SMILAX

E. A. Beaven, Evergreen, Ala. Southern Wild Smilax; Log Moaes.

For page see List of Advertisers.

New Offers in This Issue.**CATTLEYA TRIANAE, C. LABIATA, ONCIDIUM VARICOSUM****ROGERSII.**

Lager & Hurrell, Summit, N. J.

For page see List of Advertisers.

HARDY PERENNIALS.

The Storrs & Harrison Co., Painesville, O.

For page see List of Advertisers.

KEYSTONE CEDAR PLANT TUBS.

Henry A. Dreer, 714 Chestnut St., Phila.

For page see List of Advertisers.

NURSERY STOCK.

F. E. Conine Nursery Co., Stratford, Conn.

For page see List of Advertisers.

SEEDS, BEANS AND PEAS.

W. F. Allen, Salisbury, Md.

For page see List of Advertisers.

SPRING FLOWERING BULBS.

H. F. Mitchell Co., Philadelphia.

For page see List of Advertisers.

GREENHOUSES BUILDING OR CONTEMPLATED.

Auburn, Me.—G. M. Roak, additions.

Gorham, Me.—N. A. Hannaford, additions.

Belleville, Mo.—A. S. Halstead, range of houses.

La Crosse, Wis.—Mrs. A. Guillaume, one house.

Westboro, Mass.—R. O. Stockbridge, one house.

Fall River, Mass.—Paul Denare, house 24x100.

Fruitvale, Cal.—Thorsted & Co., carnation houses.

Sayre, Pa.—A. L. Merrill, three houses, 20x145 each.

Milton, N. Y.—W. H. Donaldson, carnation house, 55x110.

Wichita, Kan.—W. E. Bidleman, range of houses, 140x150.

FIRE RECORD.

The greenhouses of Paul F. Tauer, Lebanon, Ind., were destroyed by fire on April 9; loss, \$2,500; no insurance.

E. C. Ryman's greenhouses at Newark, N. J., were destroyed by fire on March 29; loss, \$2,500; insurance, \$1,500.

Herman Bowman, florist of White Plains, N. Y., was a loser in a fire which destroyed the Brandes Building, April 10.

Early on the morning of April 13 fire was discovered near the boiler in Napoleon Lemay's greenhouse, New Bedford, Mass. It was soon under control, but considerable glass was broken by the streams of water directed toward the blaze.

Mr. Knopf, of the B. K. & B. Floral Company, has in Ruby a phenomenal carnation, it being a sport from Harry Penn, with all the characteristics of that variety except flower and stem, which are magnified practically three-fold. The production of this mammoth bloom does not appear to exhaust the plant, however, and the crop seems to be equal in number of blooms to that of the parent variety.

List of Advertisers

Advance, The Co.....	583	Leonard I. & J.....	574
Allen J. K.....	574	Lenthay A. & Co.....	569
Allen W. F.....	585	Lewis A. F. Mfg. Co.....	571
Altmo Culture Co.....	567	Lord & Burnham Co.....	584
American Nursery Co.....	566	Littlefield H. F.....	554
American Nursery Co.....	564	Manda Jos. A.....	569
Aschmann G.....	579	Mann, Alex. Jr. Co.....	572
Atlanta Floral Co.....	571	MacMikin E. A.....	571
Bambrick Thos. H.....	581	McCarthy N. F. & Co.....	575
Barrows H. H. & Son.....	569	McConnell Alex.....	570
Bayersdorfer H. & Co.....	572	McKellar Charles W.....	572
Bay State Nurseries.....	566	McKissick, W. E.....	572
Beaven E. A.....	572	McMaus Jas.....	574
Berning H. G.....	575	Metropolitan Ma-	
Bloomersdale Seed		terial Co.....	582
Farms.....	567	Michell H. F. Co.....	566-582
Boddington A. T.....	566-567	Michigaa Cut Flower	
Boston Florist Letter		Exchange.....	575
Co.....	571	Milling Bros.....	575
Boston Plate and Win-		Milling Frank.....	575
dow Glass Co.....	582	Moltz, A.....	575
Bosch, Felix.....	569	Moninger J. C.....	583
Bostrom-brody Mfg.		Moore Frank L.....	582
Co.....	573	Moore, Hentz & Nash.....	575
Bowe, M. A.....	570	Moore, J. L.....	564
Braslan Seed Growers		Morris Nursery Co.....	564
Co.....	567	Morse C. C. & Co.....	567
Breck Joseph & Sons.....	567	Murdoch J. B. & Co.....	572
Bretmeyer's J. Sons.....	570	Murray Samuel.....	570
Bremond Marital.....	568	New England Nur-	
Bridgeman's Seed		series.....	564
Warehouse.....	567	Niessen Leo. Co.....	572
Budlong J. A.....	572	Ordonez Bros.....	569
Burpee W. A. & Co.....	567	Onwerkerk P.....	564
Carrillo & Baldwin.....	569	Palethorpe P. R. Co.....	582
Cassidy I.....	583	Park Floral Co.....	570
Champion J. N. & Co.....	571	Payne John A.....	583
Chicago Carnation		Pennock-Meehan Co.....	572
Co.....	554	Perkins St. Nurseries.....	569
Clarke's David, Sons.....	570	Peter's Nursery Co.....	564
Clary's Horticultural		Pierce F. O. Co.....	582
Co.....	575	Pierson, A. N.....	554
Conard & Jones Co.....	554	Pierson F. R. Co.....	556
Conine The F. E. Nur-		Pierson U. Bar Co.....	584
series Co.....	564	Piehlmann Bros. Co.....	566
Cooke G. H.....	570	Pratt C. S.....	565
Cowee A.....	554	Pulverized Manure Co.....	582
Craig, Robt. Co.....	564	Quaker City Machine	
Dana W. J.....	581	Co.....	583
Dingee & Leonard Co.....	566	Rawson W. W. & Co.....	582
Duane Geo. B. & Son.....	83	Raynor John L.....	574
Donohoe W. H.....	570	Red Oak Nurseries.....	554
Dorner F. Sons & C.....	554	Reed & Keller.....	575
Dreer H. A. 555 181-583		Reid Edw.....	572
Dunlop John H.....	571	Reinberg Peter.....	572
Dysart R. J.....	571	Rice Bros.....	572
Eagle Metal & Sup-		Rickards Bros.....	566
ply Co.....	583	Robinson H. M. & Co.....	575
Edgar, W. W. Co.....	568	Rock Wm. L. Flo. Co.....	570
Edwards Folding Box		Roehrs Julius Co.....	569
Co.....	572	Roland, Thomas.....	569
Elliott Wm. & Sons.....	53	Rolker August & Sons.....	582
Esler J. G.....	581	Rose Hill Nurseries.....	564
Ernest W. H.....	582	Sander & Son.....	566
Eyres.....	570	Schulz Jacob.....	570
Farquhar R. & J. & Co.....	556	Scott, John.....	569
Fearich J. S.....	574	Sheridan W. F.....	574
Fiske, H. E. Seed Co.....	577	Shurtleff J. B. & Son.....	554
Foley Mfg. Co.....	583	Siggers & Siggers.....	583
Ford Bros.....	574	Sim, Wm.....	569
Froment H. E.....	574	Sitinations & Waits.....	581
Galvia Thos. F.....	71	Skidelsky S. S.....	554
Grey T. J. Co.....	567	Slina B. S. Jr.....	574
Gude Bros. Co.....	570	Smyth Wm. J.....	570
Guttman Alex. J.....	574	Standard Plate Glass	
Haerens A.....	554	Co.....	582
Hatl Asso.....	583	Stearns A. T. Co.....	583
Haines, J. E.....	554	Storrs & Harrison.....	565
Hart, Geo. B.....	571	Stumpp & Walser Co.....	582
Hartmann Hjalmar &		Sunnywood Green-	
Co.....	567	houses.....	581
Hanswirth M. C. & J. E.....	570	Thorburn J. M. & Co.....	567
Herbert David & Son.....	564	Totty Chas. H.....	564
Hews A. H. & Co.....	581	Tower Hotel.....	553
Hicks Frank S. & Co.....	575	Traendly & Schenck.....	574
Hilffner Bros.....	582	Valente, J. A.....	570
Hill, The E. G. Co.....	56	Velthuis K.....	569
Hippard.....	583	Vick's Jas. Sons.....	567
Hoening W. J.....	563	Vicent R. Jr. & Sons.....	554
Hoffman.....	571	Ward R. M. & Co.....	568
Horan E. C.....	574	Water John & Sons.....	564
Houghton & Clark.....	571	Weathered Co.....	581
Huet E. H.....	582	Weber F. C.....	576
Jackson Nurseries.....	566	Weeber & Don.....	567
Jager, Chas. J. Co.....	582	Welch Bros.....	572
Kasting W. F.....	575	Wilson.....	570
Kentucky Tobacco		Winterston, E. F. Co.....	572
Product Co.....	582	Withold Geo. Co.....	571
Kervan Co., The.....	571	Woodrow, Sam'l A.....	575
Kessler, P. F.....	574	Yokohama Nursery Co.....	569
Klag Cons. Co.....	583	Young John.....	574
Koral Mfg Co.....	571	Young, Thos. Jr.....	570
Kramer Bros Fdy Co.....	568	Young & Nugent.....	570
Kuehler Wm H.....	575	Zangen O. V.....	567
Lager & Hurrell.....	569	Zinn J. A.....	571
Landreth D. Seed Co.....	565		
Langsahr, Alfred H.....	571		
LaTribune Horticol.....	565		

EASTER MARKET REPORTS.

(Continued from page 573)

tailers seemed disposed to invest in a little of everything, including such items as snapdragons, which were of superb quality, corn flowers, obconica primroses, which were made into very attractive bunches bordered with dark galax leaves, stocks, yellow irises, heliotrope, swainsona, and so on. The first shipment of southern lilac were in evidence but excited no particular interest outside of the Greek street dealers who, as soon as this becomes abundant and cheap, handle large quantities of it. The plant trade was fairly satisfactory to the retail people and, of course, to the growers who, as usual, had everything well sold in advance. Azaleas were in greater preponderance than ever, but fortunately the popular fancy remained loyal to these showy things and the number left over was not seriously large. Rambler roses were also in good favor, the light pink sorts apparently robbing the old Crimson Rambler of some of its former prestige and adding greatly to the attractiveness of the florists' windows. It was noticeable that the average run of plants of all kinds in sight was much below former years, and the demand for large specimens of anything was very small. Made-up baskets and jardiniere were used quite largely in some of the more pretentious stores, but as a rule the single plant without much artificial adornment held sway and evidently the public, while bent on the time-honored custom of buying and giving Easter plants, was not disposed to squander any money on finery. About the majority of stores there was an absence of any disposition to present special window displays. Azaleas lilies, genistas, hydrangeas, roses, daisies, heaths and acacias were simply herded together in gaudy confusion. Weather conditions were not conducive to outside displays and most of the material was kept indoors, deliveries being made as a rule in covered vans, although the thermometer was not low enough to make elaborate wrapping necessary. To sum up—Easter weather and Easter business might have been better, but it also might have been very much worse.

WASHINGTON

ness was done this Easter, probably larger than for several years, but as there was a larger per cent. of cheap grade flowers sold, it is probable that the net proceeds about even up with that of other years. Washington has been more than blessed in the matter of weather. It has been perfect, although a little cold for the season. Prices were unusually good, carnations wholesaling at \$4.00 per hundred. The florists will have another week to be grateful for in that the present week is the convention of the D. A. R's. One of the most noticeable novelties are the armadillo baskets; they have nothing if not novelty to recommend them, for neither beauty nor artistic merit seem to be any factor in their composition. Outside lily of the valley is coming in and thanks to the seasonably cool weather it is of very fine and lasting quality. There is an absolute wilderness of fruit blossom of unusually good quality and we trust the promise may make good in the yield



DREER'S
Florist Specialties,
KEYSTONE CEDAR
PLANT TUBS.



A 11	1 05	7 15	55.00
B 12 1/2	75	8 25	65.00
C 13 3/4	85	9 35	75.00
D 14 1/2	90	11 00	90.00
E 15 1/2	1 25	13 75	110.00
F 16 1/2	1 50	16 50	130.00

Three largest sizes have handles

Special PAUL TUBS.
8 inches. 30 3.50 28.00
11 " 30 3.50 28.00

Painted Green.
HENRY A. DREER,
714 Chestnut Street,
PHILADELPHIA, PA.

HELP WANTED

FOREMAN WANTED

A man with good experience in Roses and Carnations to take charge of a commercial establishment growing for the wholesale trade.

W. J. DANA

Wellesley Hills, Massachusetts

SITUATIONS WANTED

GOOD MEN

When you need good men, skilled or unskilled, Write:

THOS. H. BAMBRICK

34 South 7th Street Philadelphia

Help of all kinds, including that for Florists, Nurserymen, Seedsmen and the Horticultural trade generally.

WANTED Situation in stove or retail department of a greenhouse by experienced worker in sales and making-up department. First-class references. Foreman position preferred. C. S. care R. & J. Farquhar & Co., 6 & 7 So. Market St., Boston.

GARDENER Situation wanted on a private estate, or assistant in greenhouse; thoroughly experienced in all details of outdoor gardening; country estate preferred. Alex. D. Salomons, No. 34 Central Sq., Lynn, Mass.

WANTED Situation as gardener or manager, private place preferred; graduate of Massachusetts Agricultural College; good experience since; best of references. Address D. C. care HORTICULTURE.

FOR SALE

FOR SALE—A large consignment of 16x24 double thick American glass, A and B quality. For further information write Parshelsky Brothers, 59 Montrose Avenue, Brooklyn, N. Y.

FOR SALE—A magnificent pair of Century Plants, 30 years old. Price reasonable. Address Judge Smith's Hotel, 167th Street and Jerome Ave., New York City.

Tobacco Paper "NICO-FUME" LIQUID
 IS THE **STRONGEST, BEST PACKED, EASIEST APPLIED.** **OVER 40% NICOTINE**
Furnishes the Most Nicotine for the Money! **By far the CHEAPEST.**
 JUST NOTE PRICES!
 24 sheets.....\$ 0.75
 144 sheets..... 3.50
 288 sheets..... 6.50
 1728 sheets..... 35.10
 Pint.....\$ 1.50
 1/2 Gallon..... 5.50
 Gallon..... 10.50
 5 Gallons..... 47.25
 ... Manufactured by ...
THE KENTUCKY TOBACCO PRODUCT CO., Louisville, Ky.

A Good Thing
 between faucet and jet is

HOSE
 Tested for years and adopted by the
Sunnywoods Greenhouses
 (The place of origio of the rose BRIDESMAID)
MADE IN TWO BRANDS:
Sunnywoods
 and
Sunnywoods Extra
 In two sizes:—three-quarter and half-inch. In two lengths:—50 ft. and 30 ft. (Both sizes have 3/4 inch couplings.)
PRICES.

"Sunnywoods" — 3/4 inch, 16c.; 1/2 inch, 15c. per ft.
 "Sunnywoods Extra" — 3/4 inch, 17c.; 1/2 inch, 16c. per ft.
 The material of both brands is of the best. The "Sunnywoods Extra" is the heavier of the two brands.
 For the purpose of introduction, this special offer is made:
 If you send cash with your order, deduct one cent per foot from the price. And on all cash purchases of more than one hundred feet, freight will be prepaid.
FRANK L. MOORE
 CHATHAM, NEW JERSEY
 NEW YORK OFFICE, 57 West 26th Street

STANDARD FLOWER POTS
 Packed in small crates, easy to handle.
 Price per crate
 1500 2 1/2 in. pots in crate \$4.88
 1500 2 1/4 " " " 5.25
 1500 2 1/8 " " " 6.00
 1000 3 " " " 5.00
 800 3 1/2 " " " 5.80
 500 4 " " " 4.50
 320 5 " " " 4.51
 144 6 " " " 3.16
 Price per crate
 1200 7 in. pots in crate \$4.20
 60 8 " " " 3.00
HAND MADE
 48 9 in. pots in crate \$3.6c
 48 10 " " " 4.8c
 24 11 " " " 3.6c
 24 12 " " " 4.8c
 24 12 " " " 4.8c
 12 14 " " " 4.8c
 6 16 " " " 4.50
 Seed pans, same price as pots. Send for price list of Cylinders for Cut flowers, Hanging Baskets, Lawo Vases, etc. Ten per cent. off for cash with order. Address **Hilfinger Bros., Pottery, Fort Edward, N. Y.** August Holker & Sons, Agts., 81 Barclay St., N. Y. City.

Standard Flower . . POTTS
 If your greenhouses are within 500 miles of the Capitol, write us, we can save you money
W. H. ERNEST
 28th and M Street WASHINGTON D. C.

DON'T EXPERIMENT
 USE
To-BAK-INE
 and your stock will be free from insects, clean, and the blooms will not be discolored.
 Send for full information of
W. W. RAWSON & CO., 5 Union St., Boston.
STUMPP & WALTER CO., 50 Barclay St., New York.
HENRY F. MICHELL & CO., 1018 Market St., Philadelphia.
E. H. HUNT, Gen'l Agent, 76-78 Wabash Ave., Chicago.



The Best Bug Killer and Bloom Saver

For **PROOF**
 Write to
P. R. Palethorpe Co.
 OWENSBORO, KY :

JAGER SPRAYERS
 are money makers and work right, with little labor and without wasting solution. We make an outfit for every need, from large Power Sprayers to small Hand Sprayers—each the best of its kind. **Special Sprayer Book Free**, illustrating and describing our complete line. Investigation pass.
J. Jager Co., 241 S Franklin St., Boston, Mass.
 Branch: 50 Canal St., Providence, R. I.

GREENHOUSE GLASS
Cheaper Now Than For Years
 We are taking contracts for next Spring delivery.
WRITE FOR OUR PRICES
STANDARD PLATE GLASS COMPANY
 26-30 Sudbury St. 61-63 Portland St.
 BOSTON, MASS.

METROPOLITAN MATERIAL CO.
GREENHOUSE WRECKERS
GLASS Look at these prices. New American 50 ft. to the box, 8 x 10 single \$1.77 per box, 10x12, 12x12 B. double \$2.07 per box, 12x14 to 12x20, 14x14 to 14x20, 16x16 and 16x18 B. double at \$2.23 per box, and 16x20, 16x24, 12x24 B double \$2.35 per box. Discount on large quantities. Let us quote you on
CYPRESS MATERIAL HOTBED SASH BOILERS PIPE FITTINGS HOTBED FRAMES MATS
 1398-1408 METROPOLITAN AV., BROOKLYN, N. Y.

BOSTON PLATE & WINDOW GLASS CO.
GREENHOUSE GLASS
 German and American
 261 to 287 A St., Boston 20-22 Canal St.

MASTICA
 FOR Greenhouse Glazing
USE IT NOW.
F. O. PIERCE CO.
 12 W Broadway and 227 Greenwich St. NEW YORK

Cattle Manure
 Shredded or Pulverized
WIZARD BRAND MANURES
 Best and safest manure for florists and greenhouse use, absolutely pure, no waste, no danger. Write for circulars and prices.
The Pulverized Manure Co., 31 Union Stock Yards, Chicago

JOHN A. PAYNE

**GREENHOUSE
Designer & Builder**

260-274 Culver Ave.
JERSEY CITY, N. J.



**IRON FRAME
SEMI-IRON FRAME
TRUSS ROOF
WOOD FRAME**
Material Only or Erected

Everything for the Greenhouse

IRON PIPE

SECOND HAND

WROUGHT IRON PIPE, for Steam,
Water, Gas or Oil, Fences or Posts.
All Sizes. Price Low.

GEO. B. DOANE & SON
18 Midway Street, BOSTON
Telephone, Main 4419

ISAAC CASSIDY

Summer Ave. & Erie R.R., Newark, N. J.

Write for Prices

**GREENHOUSE MATERIAL
CONSTRUCTION FITTINGS
Bench Fittings**

Material Furnished and Erected

R. TONAWANDA
N. Y.

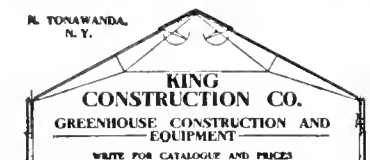

GREENHOUSE CONSTRUCTION LUMBER

John C. Moninger Co.
117 E. Blackhawk St., CHICAGO

**Holds Glass
Firmly**
See the Point
PEERLESS

**FULL SIZE
N. 2**

Glazing Points are the best
No rights or lefts. Box of
1,000 points 75 cts. postpaid.
HENRY A. DZEEB,
114 Chestnut St., Philadelphia, Pa.

THE FOLEY MFG. CO.

CHICAGO

Completely equipped with up-to-date machinery for the making
of material for

GREENHOUSE CONSTRUCTION

From a Full Supply of Thoroughly Seasoned Lumber

Send your sketches to our draughtsmen for completion and suggestion.
Permit us to figure your proposed work, large or small.

We guarantee our prices will save you money
FOLEY VENTILATING APPARATUS IS THE BEST

Simple in Erecting. Is Easiest of Operation. It Will Last a Lifetime. Its Price
is the Lowest. Will Ventilate Any Size House. Prices and Circulars on Application.

Our 1908 Catalogue Greenhouse Material Sent Postpaid on Request.

THE FOLEY MFG. CO., WESTERN AVENUE
25th and 26th STS., CHICAGO

THE STANDARD STEAM TRAP

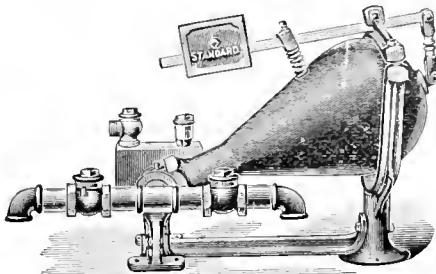

is acknowledged the best for the
florist, because it is durable and
does its work without trouble and
annoyance, saving its cost by the
economy in coal bills.

E. HIPPARD

YOUNGSTOWN, OHIO

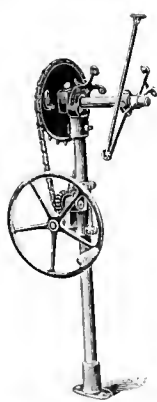

The Advance Ventilating Apparatus

Our line has been "pushing"
its way into the good graces of
florists in 38 states in 4 years'
time. Its "pull" has been its
intrinsic merits, making it possible
to sell 68 machines, 37—0
—24—16—3, respectively, to
single florists, together with
scores of sales of 5 to 10 machines
to others. Get our estimate,
and give us a trial. You
will be pleased.

The Advance Co.
RICHMOND, IND.

CYPRESS SASH BARS

82 feet or longer
HOT BED SASH
PECKY CYPRESS BENCH LUMBER

GREENHOUSES

ERECTED AND EQUIPPED COMPLETE IF DESIRED

Write for Circular "D" and Prices

The A. T. STEARNS LUMBER CO.
NEPONSET, BOSTON, MASS.

SECOND HAND PIPE & BOILER TUBES

Of all sizes, in good condition, suitable
for steam purpose, coupled and threaded,
for sale at low rates.

5000 feet 1 inch pipe, 3c. per ft.; 5000
feet 1 1/4 inch pipe, 4c. per ft.; 3000 feet
1 1/2 inch pipe, 5c. per ft.; 2000 feet 2 inch
pipe, 6 1/2c. per ft.

EAGLE METAL & SUPPLY CO.,
Johnson and Union Aves., BROOKLYN, N. Y.

In writing advertisers kindly mention
HORTICULTURE.



Evans 20th Century Arm

Will not twist your shafting pipe. Give it
a trial and you will use no other. Three
times the power of elbow arms.

Write for Catalogue

QUAKER CITY MACHINE CO.
Richmond, Ind.

PATENTS

Trademarks and
Copyrights

Send you business direct to Washington.
Saves time and insures better service.
Personal attention guaranteed.
Twenty-five years' active service.
SPECIALTY: "Working on the Failure
of Others."

SIGGERS & SIGGERS

PATENT LAWYERS

Box 9, National Union Building
Washington, D. C.

**THE FLORISTS' HALL ASSOCIATION
OF AMERICA,** insurer of 28,000,000
sq. ft. of glass. For particulars address
John C. Esler, Sec'y, Saddle River, N. J.

THE HOUSE OF GREATEST SUNLIGHT

LIGHTEST INTERIOR in the WORLD
THIS HOUSE 33 1/2 FEET WIDE
Note: No Columns

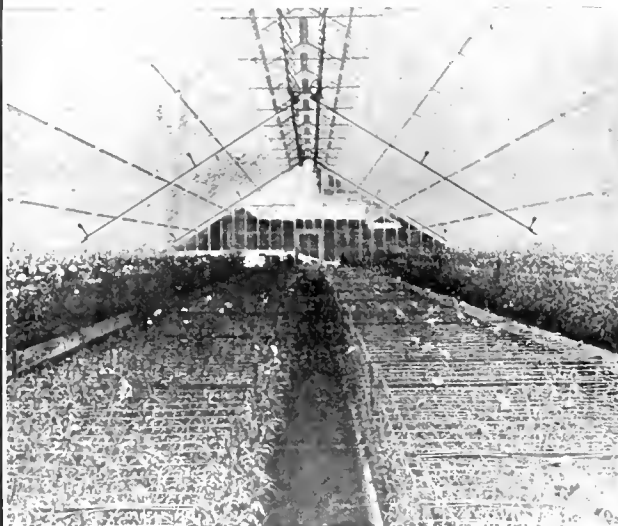

Erected for J. J. BROZAT, Bloomfield, N. J.

BY THE

WEATHERED COMPANY

IRON FRAME, SEMI-IRON FRAME, OR ALL SASH
BAR HOESLS, ERECTED, OR MATERIAL ONLY

P. O. Address Box 789

NEW YORK CITY, N. Y.

CLAMP BENCH FITTINGS

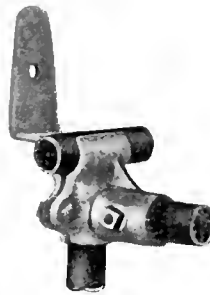

The Main Fitting

For an easy to erect—
easy to repair—rigid—
lasting bench, use our
Special Pipe Bench Fit-
tings. Send for circular
and prices.

WE MAKE EVERY PART OF A GREENHOUSE
BUT THE GLASS. WE SELL ANY PART.

LORD & BURNHAM CO.

MAIN SALES OFFICE:

1133 BROADWAY, NEW YORK

BOSTON: 815 Tremont Building
PHILADELPHIA: 1215 Filbert St.

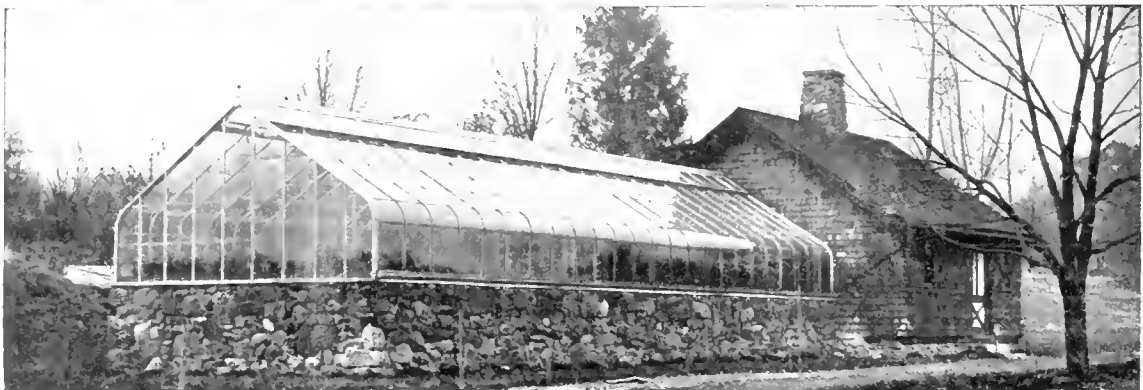

THEY HAVE WIDE GLASS

and wide glass means more light — and more light means better plants, better blooms. The catalog tells why they are the lightest, simplest, strongest, most durable, most attractive and productive houses built, and cost less to maintain.

The ideal construction for private estates, parks, public institutions and florists' show rooms. Send for catalog.

U-BAR GREENHOUSES

PIERSON

DESIGNERS AND BUILDERS



U-BAR CO.

1 MADISON AVE., NEW YORK

HORTICULTURE

Vol. VII. MAY 2, 1908 No. 18



CALCEOLARIA HYBRIDA

Devoted to the
**FLORIST, PLANTSMAN,
 LANDSCAPE GARDENER,**
 and
Kindred Interests

Published
EVERY SATURDAY
 At 11 Hamilton Place,
 BOSTON, MASS.
 Subscription, \$1.00

MAY 4 - 1908

CANNA BULBS

Fine Blue Northern Crown, and in no condition. Not to be compared with Southern grown stock that are never thoroughly ripened and therefore are very slow to start growing.

	1 lb.	2 lb.	3 lb.	4 lb.	5 lb.	6 lb.	7 lb.	8 lb.	9 lb.	10 lb.
Allemania	\$1.50	\$2.50	\$3.50	\$4.50	\$5.50	\$6.50	\$7.50	\$8.50	\$9.50	\$10.50
Black Prince	1.00	1.50	2.00	2.50	3.00	3.50	4.00	4.50	5.00	5.50
Black Warrior	1.00	1.50	2.00	2.50	3.00	3.50	4.00	4.50	5.00	5.50
Burbank	1.00	1.50	2.00	2.50	3.00	3.50	4.00	4.50	5.00	5.50
Black Musafolia	1.00	1.50	2.00	2.50	3.00	3.50	4.00	4.50	5.00	5.50
Charles Henderson	1.00	1.50	2.00	2.50	3.00	3.50	4.00	4.50	5.00	5.50
Director Roelz	1.00	1.50	2.00	2.50	3.00	3.50	4.00	4.50	5.00	5.50
Flamingo	1.00	1.50	2.00	2.50	3.00	3.50	4.00	4.50	5.00	5.50
Florence Naughtan	1.00	1.50	2.00	2.50	3.00	3.50	4.00	4.50	5.00	5.50
Golden Star	1.00	1.50	2.00	2.50	3.00	3.50	4.00	4.50	5.00	5.50
Gladistor	\$0.40	\$0.50	\$0.60	\$0.70	\$0.80	\$0.90	\$1.00	\$1.10	\$1.20	\$1.30
King Edward	1.00	1.50	2.00	2.50	3.00	3.50	4.00	4.50	5.00	5.50
Louisiana	1.00	1.50	2.00	2.50	3.00	3.50	4.00	4.50	5.00	5.50
Mad. Crozy	1.00	1.50	2.00	2.50	3.00	3.50	4.00	4.50	5.00	5.50
Mlle. Berat	1.00	1.50	2.00	2.50	3.00	3.50	4.00	4.50	5.00	5.50
Musafolia	1.00	1.50	2.00	2.50	3.00	3.50	4.00	4.50	5.00	5.50
Paul Marquant	1.00	1.50	2.00	2.50	3.00	3.50	4.00	4.50	5.00	5.50
Pres. McKinley	1.00	1.50	2.00	2.50	3.00	3.50	4.00	4.50	5.00	5.50
Queen Charlotte	1.00	1.50	2.00	2.50	3.00	3.50	4.00	4.50	5.00	5.50
Robusta	1.00	1.50	2.00	2.50	3.00	3.50	4.00	4.50	5.00	5.50
Red Cross	1.00	1.50	2.00	2.50	3.00	3.50	4.00	4.50	5.00	5.50

STUMPP & WALTER CO., 50 Barclay St., NEW YORK

COLEUS

Verschaefeltii, Golden Queen, Fire Brand, Lord Palmerston, Queen Victoria, Beckwith's Gem. Prices of Rooted Cuttings by express, foot per 100. \$5 per 1000. Less than 100 of a variety will be charged at the 100 rate.
 Golden Bedder, Hero, Tessey Pearl of Orange, 100 per 100. \$5 per 1000. Less than 100 of a variety will be charged at the 100 rate.
 Fancy Varieties. A very fine assortment of twelve extra big listed above, 100 per 100. \$5 per 1000. 1000 in assortment, our selection, at the 100 rate.

MISCELLANEOUS PLANTS

AGERATUM Stella Gurney, Princess Pauline, SALVIA Splendens Bonfire, HELIOTROPE. Rooted cuttings, 100 per 100. \$5 per 1000.

CARNATIONS

Rooted Cuttings
 Winsor 100 1000
 White Perfection 100 1000
 Rose Pink Enchantress 100 1000
 Enchantress 100 1000
 Queen Louise 100 1000
 From 100, 1000 pots, add \$1.00 per 100.

ASPARAGUS PLUMOSUS MANUS SEEDLINGS
 From 100, \$1.00 per 1000.

CHRYSANTHEMUMS

Standard varieties, ready for shipment. Rooted cuttings, \$1 per 100. \$5 per 1000. Seed for list.

A. N. PIERSON, CROMWELL, CONN.

CARNATIONS

WINONA—The True Pink

\$12.00 per 100 \$100.00 per 1000

	Per 100	Per 1000
Red Chief	\$5.00	\$50.00
Aristocrat	1.00	10.00
Winsor	1.00	10.00
Beacon	1.00	10.00
White Perfection	1.00	10.00
Rose Pink Enchantress	1.00	10.00
Enchantress	1.00	10.00
Lady Bountiful	1.00	10.00

F. DORNER & SONS CO., LAFAYETTE, IND.

A HALF MILLION CALLA BULBS FOR SALE

CALLA ETHIOPICA BULBS

A. MITTING, 17 to 23 Kennan St., Santa Cruz, Cal.

YOU WANT THEM NOW

Before the rest of the varieties is all sold. The finest stock of standard

HARDY PERENNIALS

in the country. Write and we will quote tempting prices

Red Oak Nurseries, Fiskeville, R. I.

Single Chrysanthemums ARE THE CRAZE

Are you in line to meet the demand?

- KATE, COVILL, BOB, ROY, HELEN, TOTTIE, HAROLD, BISHOP, MRS. LUTER, MEYER, ANNA, SPANGLE

CHAS. H. TOTTIE, MADISON, N. J.

GLADIOLI

I can satisfactorily supply your wants for Gladioli for forcing or outdoor planting. Many of our seedlings are named varieties of exceptional beauty.

ARTHUR COWEE
 Gladiolus Specialist
 Meadowdale Farm, BERLIN, N. Y.

CANNAS

Send for our List and Prices
 The CONARD & JONES CO., WEST GROVE, PA.

J. B. SHURTLEFF & SON, Cushman Ave., Revere, Mass.

Established 40 Years
Rose Hill Nurseries
 New and Rare Plants
 NEW ROCHELLE, N. Y.
 New York Office: Beersman Building, 425 Fifth Avenue

ROOTED CARNATION CUTTINGS

Only the Best Varieties
 CHICAGO CARNATION CO., SOMETHING GOOD FOR SMALL PRICE

5000 1 1/2-2 in Salvia Splendens \$2.00 per 100
 10000 Enchantress Carnations 2.00
 1000 Prosperity 2.00
 500 Winsor 6.00

JOHN E. HAINES, Bethlehem, Pa.

John E. Haines, red Imperial variegated, Pink Imperial, Pink Enchantress, Light Pink. Place your orders early for Jan. delivery.

Carnation Cuttings
 Both standard varieties and novelties. Stock guaranteed to be first class. Address:
 S. S. SKIDELSKY
 1741 North 15th Street, Philadelphia

GLADIOLUS BULBS

100 1000 from 1000 bulbs at \$1.00 per 1000
 100 1000 from 1000 bulbs at \$2.00 per 1000
 I. & J. L. LEONARD, IONA, N. J.

MONEY MAKERS

H. L. CAMERON
 North Cambridge, Mass.

DREER'S SEASONABLE SPECIALS

Hardy Perennial Phlox

We are Headquarters for these. More than one hundred and fifty thousand one year old field grown plants now in pots.

Collection of Choice Standard Phloxes

- Aquillon
 - Andreas Hoffer
 - Bouquet Fleuri
 - Bride-maid
 - Peranger
 - Bacchante
 - Clara Benz
 - Champs Elysee
 - Eclairneur
 - Eugene Danzanvillier
 - Eclairmonde
 - Graff von Ungerer
 - H. O. Wilers
 - Henry Murger
 - Inspector Peiker
 - Jeanne d'Arc
 - La Vague
 - Otto Thalacker
 - Obergartner Wittig
 - Pantheon
 - Pechen d'Islande
 - Pacha
 - Professor Schlieman
 - Papillon
 - B. P. Stenther
 - Sunshine
 - Thebaide
 - Von Goethe
- Price choice standard varieties \$1.00 per doz. \$3.00 per doz. \$5.00 per doz.

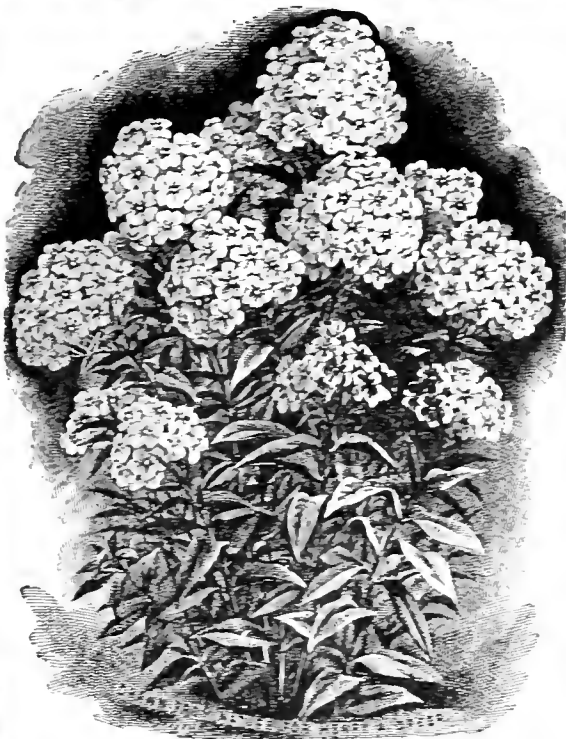

Hardy Phlox

New and Rare Hardy Phloxes

Name	Price	Price	Price
Albion	\$1.00	\$3.00	\$5.00
B. Comte	\$1.00	\$3.00	\$5.00
Coquelicot	\$1.00	\$3.00	\$5.00
Etna	\$1.00	\$3.00	\$5.00
F. G. von Lassburg	\$1.00	\$3.00	\$5.00
Hermine	\$1.00	\$3.00	\$5.00
Inspector Elpel	\$1.00	\$3.00	\$5.00
Jules Cambon	\$1.00	\$3.00	\$5.00
Le Mahdi	\$1.00	\$3.00	\$5.00
Mrs. Jenkins	\$1.00	\$3.00	\$5.00
Michael Cervantes	\$1.00	\$3.00	\$5.00
Selma	\$1.00	\$3.00	\$5.00
Vesuvius	\$1.00	\$3.00	\$5.00

JAPANESE ANEMONES

Not the water lily or lily as usually called, but a distinct species of the lily family, with a very different habit of growth and a very different color and form of flower.

Name	per doz.	per doz.	per doz.
Japonica Rosy reg.	\$1.00	\$3.00	\$5.00
White reg.	\$1.00	\$3.00	\$5.00
Large white reg.	\$1.00	\$3.00	\$5.00
Large white reg.	\$1.00	\$3.00	\$5.00
Large white reg.	\$1.00	\$3.00	\$5.00
Large white reg.	\$1.00	\$3.00	\$5.00
Large white reg.	\$1.00	\$3.00	\$5.00
Large white reg.	\$1.00	\$3.00	\$5.00

Japanese Iris—The Iris which we call the Japanese Iris is a distinct species of the Iris family, with a very different habit of growth and a very different color and form of flower.

Name	per doz.	per doz.	per doz.
Japanese Iris	\$1.00	\$3.00	\$5.00

Tritoma Pfizeri—The beautiful Red Hot Poker plant, with its tall, slender stems and large, tubular flowers, is a distinct species of the Tritoma family.



Tritoma Pfizeri

HENRY A. DREER,

714 Chestnut St., Philadelphia, Pa.



A HOUSE OF LONGIFLORUM FORMOSUM GROWN BY E. LIEBER, LANSDOWNE, PA.

Bulbs supplied by Henry F. Michell Co., Philadelphia.

THE NEW EASTER LILY

(**FORMOSA** *Lilium Longiflorum*)

Originator's Stock

A decided improvement over any previous type of Japanese Easter Lily, having proven to be free from disease. During the past season we imported a limited quantity of these bulbs as an experiment, and distributed them among some of the largest Lily growers in this country, they were all very well pleased with it. One party to whom we sold 1500 had 1500 good plants when his house was examined before Easter. They were coming into bud splendidly, and showed not the slightest sign of disease. The height of this Lily with average culture is a little taller than the Multiflorum, being from 3 to 3½ feet. 6.8 inch bulbs produce about 3 to 4 blooms. 7-9 inch bulbs produce about 4 to 6 blooms. 9-10 inch bulbs produce about 6 to 8 blooms. The variety itself makes an especially good one for the Lily grower to handle, because it may be potted about the middle of August or beginning of September, which will allow the grower to handle it in all the different temperatures that he desires, without extreme forcing.

One Lily grower gave us his opinion as follows: "I have been growing Lilies in very large quantities for years, but must admit that the 'Formosa *Lilium Longiflorum*' that you supplied me is the best that I have ever handled." This party has already booked his order with us for a very large number for next year's delivery.

The Formosa *Lilium Longiflorum* is also reported as desirable for Christmas forcing, it can be had in flower just as easily, in fact it is more certain to be than *Lilium Harrisii*.

READY IN AUGUST

PRICES: 6.8 in. bulbs (400 bulbs per case) per 100, \$4.25; per 1000, \$40.00. 7-9 in. bulbs (300 bulbs per case) per 100, \$8.00; per 1000, \$75.00. 9-10 in. bulbs (200 bulbs per case) per 100, \$11.00; per 1000, \$105.00

Original Strain Procurable from

HENRY F. MICHELL CO., Seedsmen, Direct Importers of Highest Quality Bulbs, 1018 Market St., Philadelphia, Pa.

Stock Queen Alexandra



The Beauty of Nice stock has proved a most useful winter flowering variety and is finely grown in many establishments. The variety Queen Alexandra, however, surpasses it in every way by reason of its clear, bright, rosy lilac color. The illustration shows a typical plant of which we had a 100-foot bench during the past winter and nearly 90 per cent. were perfectly double; in fact this particular bench of Queen Alexandra when in flower was a beautiful picture and furnished an enormous quantity of cut flowers.

The plants were raised from seed sown in July and they were carried along in frames, being potted on into 4-inch pots and afterwards planted out upon a bench that had been cropped with Beatrice May and Soliel d'Octobre chrysanthemums. There was ample fertility in the old chrysanthemum soil to perfect the crop of stocks; in fact the plants grew to great size and were profusely branched.

Those who lack the facilities for planting out may still grow this stock and will find it a delightful subject for pot culture. With the roots confined in a pot the plant shows less disposition to branch but the individual main spike is larger in every way, with the flowers closely set thereon, and the plants come earlier into flower as a result of root confinement. In fact this stock is amenable to many uses, and another effective way of growing it is to put three plants in a larger-sized pot. It is certainly a good plant for the gardener who seeks to vary his cut flower productions during the winter months.

Arthur Herrington

Culture of the Calceolaria

The calceolaria should have a prominent place amongst our spring flowering plants; being so well adapted for either greenhouse or house decoration and having such a splendid variety of color. Having grown the calceolaria for some years with favorable results under the following methods I venture a few remarks on its culture.

The first thing to consider is the best variety to grow. There are several good strains on the market. The plants illustrated on the frontispiece of this paper were grown from seed procured from Arthur T. Boddington.

SOWING THE SEED

The soil for this purpose should consist of finely-sifted loam, leaf-soil, and a good proportion of sand. Fill some well drained 5 in. pots or shallow pans as the case may be to one inch from the top, then give a watering and let the pots stand for a time to drain. Be careful not to sow too thickly and cover the seed very lightly with some finely sifted sand. After sowing cover the pots or pans with a sheet of glass. In about twelve or fifteen days the seedlings should appear. Remove the glass to prevent damping and stand the pots in a good airy place keeping them free from direct draughts.

POTTING

As soon as the seedlings are large enough to handle they should be pricked off, five or six plants into 4 in. pots, still keeping them as cool as possible and well in the shade. When large enough they should be potted into 2 1-2 in. pots using the same kind of compost. When these pots are filled with roots the next shift will be into 4 in. pots using a richer compost, consisting of good loam, some well rooted cow manure, leaf soil and sand. Pot the plants moderately firm.

FINISHING OFF

When ready, which should be by the early part of January, they should be shifted into their flowering pots, when a good rich soil will be necessary to finish them off. This should consist of good loam, two parts; cow manure, well-rotted, one part, with a sprinkle of bone meal and sand well mixed. They should then be potted very firmly. Be very careful not to over-water the plants for the first few weeks. A slight spraying each day will be beneficial to them. Fumigate the plants once every two weeks to ward off the attacks of green fly and other insects that are injurious. Keep the temperature from 45 to 50 degrees which will suit them admirably.

A. T. Boddington

Morristown, N. J.

HORTICULTURE

VOL. VII

MAY 2, 1908

NO. 18

PUBLISHED WEEKLY BY

HORTICULTURE PUBLISHING CO.
 11 Hamilton Place, Boston, Mass.

Telephone, Oxford 292

WM. J. STEWART, Editor and Manager

SUBSCRIPTION PRICE

One Year, in advance, \$1.00; To Foreign Countries, 2.00; To Canada, \$1.50

ADVERTISING RATES

Per Inch, 30 inches to page \$1.00.

Discounts on Contracts for consecutive insertions, as follows:

One month (4 times) 5 per cent.; three months (12 times) 10 per cent.;

six months (26 times) 20 per cent.; one year (52 times) 30 per cent.

Page and half page spaces, special rates on application.

Entered as second-class matter December 8, 1904, at the Post Office at Boston, Mass., under the Act of Congress of March 3, 1879.

CONTENTS

	Page
FRONTISPIECE— <i>Calceolaria hybrida</i> .	
STOCK QUEEN ALEXANDRA—A Herrington—Illustrated	589
CULTURE OF THE CALCEOLARIA—H. B. Vyse	589
NOTES FROM THE ARNOLD ARBORETUM—Alfred Rehder	591
BRITISH HORTICULTURE—W. H. Adsett	591
NEWS OF THE CLUBS AND SOCIETIES:	
American Rose Society—Twin Cities Florists' and Gardeners' Club—Society of American Florists—Toledo Florists' Club—Newport Horticultural Society—Club and Society Notes	592
PITTSBURG EASTER SHOWS—J. Hutchinson	593
MASSACHUSETTS AGRICULTURAL COLLEGE—Illustrated	593
PLANT FOODS—George A. Bishop	594
INFERIOR DUTCH BULBS	594
SEED TRADE	598
OF INTEREST TO RETAIL FLORISTS:	
Twin Cities—Chicago Jottings—New Retail Flower Stores	602
FLOWER MARKET REPORTS:	
Boston, Buffalo, Chicago, Detroit, New York, Philadelphia, Twin Cities, Toledo	605
MISCELLANEOUS:	
Publications Received	592
Improving the Marguerites	593
A Leathy—Portrait	594
Personal	594
Obituary	594
Four Best Zonal Geraniums	595
Plant Imports	595
Shrub Chat	596
News Notes	596-602
Catalogues Received	598
Business Changes	603
A New Flower Market Proposed	603
Incorporated	603
News of Twenty-eighth St.—A. J. Guttman—Portrait	605
Court Decision in Custom House Case	613
Greenhouses Building or Contemplated	614
List of Patents	614

A "tip" for the fall show

Now is the time to push along on the chrysanthemums for next fall's exhibitions. We hope the managers of the various shows will keep prominently in mind the growing interest of the trade and the public in the hardy pompons and the new single flowered varieties and make due provision for exhibiting these flowers, not simply in little labelled bunches in bottles, but in such manner as to bring to the attention of the public their best use for decorative effect both alone and in association with the big flowers. This is something which has not been done to any extent at any of our exhibitions thus far although it holds out perhaps the very best means for reviving the waning interest in chrysanthemum shows. There are in every community florists of exceptional artistic ability and

gardeners also who are blessed with the same talent. Fix the prize schedule so as to get them interested and do it early enough to give the necessary time for the growing of the stock required. The novelty has about gone from the showing of new varieties of chrysanthemums or the bestowal of names of prominent people thereon as far as the ticket-buying public is concerned. What can we provide to fill the gap?

A proposed insecticide bill

A bill has been introduced in the United States Senate by Senator Alfred B. Kittredge of South Dakota, entitled, "A Bill for preventing the manufacture, sale or transportation of adulterated or misbranded fungicides, Paris greens, lead arsenates and other insecticides and for regulating traffic therein, and for other purposes." This has been drafted at the instance of the Committee on Proprietary Insecticides of the Association of Economic Entomologists which includes all the official entomologists of the United States and has their hearty support. We understand it also has the support of many of the leading manufacturers of insecticides. As a measure in the interest of the manufacturer of and dealer in reputable insecticides and fungicides, we hope our readers, so many of whom are interested in having at their disposal reliable preparations for combatting the ever-increasing army of plant scourges, will give this bill a careful reading and, finding it worthy, write to their congressmen and senators in its support. The bill is very lengthy and we have not the space to present it in these columns but copies may be obtained on application to E. Dwight Sanderson, Entomologist, N. H. Agri. Exp. Station, Durham, N. H. While heartily approving the bill in its main features we think we can see where modifications of its provisions might wisely be made and would again recommend a careful reading.

The problem of the forcing bulb

We have received a number of letters and many verbal communications, most of them commendatory, on the Holland bulb problem, since the publication of our editorial note on that subject two weeks ago. The letters from Messrs. A. N. Pierson and Peter Reinberg, which appear in this issue fairly represent the sentiments of the large flower growers as same have come to our knowledge. No hostility to the Holland bulb-growing interests is expressed in any of the comments nor was any inherent in our editorial, but the method of sending annually to this country an army of travelling salesmen who penetrate every nook and cranny in quest of small orders, which our home houses are fully able to handle, and very often without due care in extending credits, is naturally looked upon by local wholesale and retail distributors as adverse to the best interests of American dealers and Holland exporters alike. The high-tension demand during the period of the bulb forcing prosperity in this country has tended also to cause more or less complaint from florists of inferior qualities and of exorbitant prices on the most popular forcing varieties and now the demoralization in a none-too-strong market for the flower growers' product, caused by the dumping thereon of large quantities of bulb stock for whatever price they will bring, is sure to have its effect on those who feel that they have suffered because of it. A certain amount of forcing bulbs will always be required but the present emergency calls for some deep thinking, as neither foreign producers nor exporters, nor American importers, forcers or flower dealers, can afford to repeat the experiences of the past season. And this applies with equal truth to material from places other than Holland.

Notes from the Arnold Arboretum

Among the shrubs blooming in these early spring days none make a more gorgeous display than the Forsythias with their golden yellow flowers. The large clump planted in the Arboretum on the slope opposite the Forest Hill entrance looks now like a sheet of gold spread out on the hillside and does not fail to attract the attention and admiration of every beholder. At the first glance there seems to be little difference between the several species and varieties of the Forsythias, or as they are also called in English, the Golden Bells, but on closer observation marked differences in color and profusion of the flowers and in habit will be noticed which ought to be taken into consideration in using these shrubs for certain purposes and effects. One of the best is the true *F. suspensa* (*F. Sieboldi*, *F. suspensa* var. *Sieboldi*), usually a rather low shrub with slender arching or drooping or sometimes trailing branches and solitary flowers of a rather deep yellow; it is well adapted for covering walls, fences, arbors and the like, as it can be treated like a low climber. For planting in shrubberies *Forsythia suspensa* var. *Fortunci* (*F. Fortunci*) is to be preferred; it is of more vigorous and more upright growth attaining to eight feet or sometimes more in height and the somewhat paler flowers appear in greater profusion. A species of more strictly upright habit is the well known *Forsythia viridissima*, which, however, is slightly inferior in its ornamental qualities to the var. *Fortunci* and is not quite as hardy at least in the neighborhood of Boston. Very similar to *F. viridissima* is *Forsythia europaea*, which is as yet little known in cultivation having been discovered only about twelve years ago in southeastern Europe; as far as can be judged from the young plants in the Arboretum, it will not surpass any of the other species in beauty. The most valuable of all Forsythias for horticultural purposes is *Forsythia intermedia* with its varieties, hybrids between *F. suspensa* and *F. viridissima*. They are more floriferous than their parents and generally of upright vigorous habit; the four following forms have been distinguished. The original *Forsythia intermedia* (*F. intermedia* var. *divaricata*) forms a somewhat spreading shrub with partly arching and pendulous branches and with solitary flowers of a rather light yellow color. *Forsythia intermedia* var. *densiflora* is of similar but more irregular habit and has the bright yellow flowers arranged in dense clusters at the base of last year's branches while on the upper part of the branches they are solitary. *Forsythia intermedia* var. *spectabilis* is of more upright habit with partly arching branches and the deep yellow flowers appear in great profusion along the entire length of the branches. *Forsythia intermedia* var. *vitellina* is of strictly upright habit with deep yellow flowers appearing in greatest profusion toward the base of the branches.

Another yellow flowering shrub or small tree now in bloom is *Cornus mas* which is also to be recommended for its lustrous dark green foliage, its compact habit and the bright scarlet fruits in autumn.

Magnolia stellata is particularly fine this year and is now in its full glory; it is certainly the most graceful of the early flowering Japanese species; a very handsome variety is the pinkish *M. stellata* var. *rosea*. *Magnolia Kobus* is also in bloom, but is far less beautiful than *M. stellata*, as its white flowers appear only rather sparingly even on older plants; it is, however, the hardiest of all the Japanese Magnolias and grows into a small tree of regular pyramidal habit.

Rhododendron mucronulatum besides the closely re-

lated *R. dahuricum* the earliest of all the Rhododendrons attracts attention by its beautiful rose-colored flowers appearing in great profusion; *R. mucronulatum* is of more vigorous and upright habit than the latter species and the deciduous foliage turns to a brilliant scarlet color in autumn.

Of the numerous species of *Prunus* the earliest of all, *Prunus Davidiana* is already past flowering, but *Prunus sibirica*, *P. Mume*, *P. Armeniaca*, *P. Amygdalus*, *P. platycarpa*, the peculiar Chinese Flat Peach, *P. triloba* and *P. tomentosa* are now in full bloom, the beautiful pink flowered *P. serrulata* and the graceful pinkish white *P. pendula* are beginning to flower and many others are soon to come. If the weather continues favorably the numerous ornamental flowering cherries, plums and apples will make a great display during this month.

Alfred Rehder.

British Horticulture

SIX GOOD ROSES

The new annual of the National Rose Society is replete with contributions from the leading rosarians. The Rev. J. H. Pemberton, one of the vice-presidents, has performed the difficult task of selecting half a dozen roses amongst the newest introductions which he considers are the very best for garden purposes. The list is as follows: Dean Hole, H. T. (A. Dickson and Sons); Earl of Warwick, H. T. (Wm. Paul and Son); George Laing Paul, H. T. (Souper & Notting); Hugh Dickson, H. P. (H. Dickson); Lady Ashtown, H. T. (A. Dickson & Sons); Trier, Cl. Poly. (P. Lambert). The latter is the offspring of a cross between *Aglaia* and Mrs. Sharman Crawford.

THE NATIONAL DAHLIA SOCIETY

Mr. H. H. Thomas, a contributor to HORTICULTURE, the new secretary to the National Dahlia Society, has issued the annual report. The past season, it is stated, must be regarded as an unfavorable one for dahlias. The summer was a very cold one, and although there were many dull and rainy days, the total rainfall was below the average. The plants were therefore quite three weeks late in blooming with the result that exhibitors had very few blooms to choose from on show day. The trial of garden cactus dahlias at Wisley by the Royal Horticultural Society in conjunction with this society was greatly marred owing to the cold season. Further trials are to be made this season at Wisley with garden cactus varieties. These are limited to the varieties which have been introduced since January 1st, 1905. The dahlia analysis, which is published by Mr. Edward Mawley, president of the society, shows that the number of entries last season in some of the sections was smaller than usual owing to the unfavorable season. In the cactus section, which is always the most popular and attractive in the show, there was a great falling off, as compared with previous years. The numbers were as follows: Cactus, number of bunches, 296; Cactus shown singly, 624; Shows, number of blooms, 478; Fancies, number of blooms, 181; Pompons, number of bunches, 210; Singles, number of bunches, 147. The society's annual show has been arranged to take place in the Royal Horticultural Hall, London, September 3rd.

W. H. Adsett.

NEWS OF THE CLUBS AND SOCIETIES.

AMERICAN ROSE SOCIETY.

It is said that the Chicago show held in March brought out the largest single assortment of cut rose specimens ever exhibited in America. The only pity was that so beautiful an exhibit had not a larger public patronage.

The settling of all the prizes is now a matter of interest—the total number of prizes is 61, of which 54 are in cash and 7 are cups, medals, books and bone.

The trade papers did much for the show by the excellent illustration which gave an idea to those who could not come, of what there was at the Art Institute. The American Rose Society has sent letters of thanks to the Chicago Florists' Club and to the president of the Art Museum for the cordial and courteous attention given to the society.

Five new life members joined the society and this brings the permanent fund now invested up to \$3,000.00. What the society now needs is that every flower grower and landscape gardener in America shall join us. We need the help. The membership now slightly exceeds that of 1907. "The Rose Journal" is to be started, but we want more support to be pledged to make it a success. Come and give assistance, you men and women who grow roses.

There is to be a June Rose Show in Bronx Park, New York, and all the growers of roses who can are invited to show. There will be no medals.

The certificates of life membership will shortly be forwarded to all new members. "A Rose for every Home, a Bush for every Garden."

BENJAMIN HAMMOND,
Secretary.

Fishkill-on-Hudson, N. Y.
May 1, 1908.

TWIN CITY FLORISTS' AND GARDENERS' CLUB.

Monthly meeting was held Tuesday, April 21, at the Minneapolis Park Greenhouses. A committee was appointed to consider the advisability of incorporating the Society as a State organization, so as to get better terms for exhibits and premiums at the State Fair.

A paper read by Mr. L. Boeglin was heartily applauded and copies will be sent to all the trade papers for publication. Theodore With confirmed the results of Mr. Boeglin's manner of raising bedding stock in frames, as being preferable to greenhouse-grown stock, the former being better hardened and growing right along, without being checked. The exhibit of the best bedding plants for this part of the country was very much appreciated.

At the meeting of the Rhode Island Horticultural Society held on April 9, in Providence, Alexander MacLellan, of Newport, presented an able paper on the dahlia which was listened to with great interest and elicited many questions.

SOCIETY OF AMERICAN FLORISTS AND ORNAMENTAL HORTICULTURISTS.

Department of Registration.

The names of the following winter-flowering Sweet Peas are submitted for registration by Ant. C. Zyzanek, Bound Brook, New Jersey.

Any persons objecting to these registrations or knowing of any reasons why they should not be made, are requested to communicate with the undersigned at once. Failing to receive any such communications within twenty days from this date, the registrations will be completed.

Greenbrook, seedling from Mrs. Geo. Lewis X unnamed seedling, height over 6ft., flower white, standard slightly lilac, very large, orchid flowering, up to four flowers to a stem, stems average 18 inches.

Blue Bird, seedling from Walter Wright X Wallace, height over 6ft., flowers blue, bearing up to four flowers on 20-inch stems, standard wavy.

Governor John Franklin Ford, seedling of Mrs. Wm. Sim X Spencer seedling, height over 6ft., foliage narrow, flower pink, when fully open changing to salmon pink, standard wavy, producing up to four flowers on 20 inch stems.

Notice of Withdrawal of Registry.

Learning that the name Mavourneen had previously been applied to a rose, Mr. Alexander Montgomery of Natick, Mass., withdraws the name Mavourneen and desires that the name White Killarney shall stand as previously registered.

W. N. RUDD, Secretary.
May 1, 1908.

TOLEDO FLORISTS' CLUB.

The meeting last Wednesday at Mr. Mills' residence was a very pleasant affair. Mrs. Mills had invited the ladies of the members and had a club for herself while the business was in progress, after which all enjoyed coffee and cakes.

A few weeks ago the club visited W. G. Hall of Clyde, who is undoubtedly one of the best carnation growers in Ohio. His plant is not very large, but what he lacks in size is made up in quality; he grows his own seedlings quite largely.

Another club visit was to Miller Bros. and Searles Bros., lettuce growers. At Miller's place cucumbers will now take the place of lettuce. Searles Bros.' new plant consists of 15 houses, 15 feet wide by 750 feet long, and the output of lettuce since October has been about two tons every day. Hot water is used, circulated by a rotary pump, and the entire plant is watered by the Skinner system. This new plant is in the near future to be enlarged until it covers 41 acres and all will be devoted to lettuce during the winter and cucumbers in summer. Besides this they have an old plant of about half the size, where cucumber picking has already commenced. The new plant used this season about 2,000 tons of coal.

J. L. SCHILLER.

NEWPORT HORTICULTURAL SOCIETY.

The premium list for the exhibition of June 23 and 24, to be held at Masonic Hall, Newport, R. I., has been issued. The prizes comprise \$125.00 for plants, \$150.00 for roses and other flowers, \$45.00 for fruit, \$30.00 for vegetables and \$50.00 for children's exhibits and school gardens. Copies of the schedule can be had on application to D. J. Coughlin, secretary.

CLUB AND SOCIETY NOTES.

Edwin Lonsdale will address the Florists' Club of Philadelphia on Tuesday evening, May 5th.

The annual meeting of the Horticultural Society of New York will be held at the Museum Building, N. Y. Botanical Garden, on May 13, at 4 P. M. An amendment to the constitution making dues of associate members \$1.00 a year will be voted on at that time, and election of officers will be held. The Foundations of Successful Violet Culture is the title of a lecture to be delivered by Dr. B. T. Galloway. The newly established orchid section will hold its first meeting on this occasion. An exhibition of plants and flowers will be held in connection with these events and will continue for two days.

PUBLICATIONS RECEIVED.

Chrysanthemum Society of America; Proceedings of the Sixth Annual Meeting, held at American Institute, New York, Nov. 6, 1907. A list of varieties disseminated in 1907 is included.

Bulletin No. 49, Vol. 6, of the New York Botanical Garden contains the reports of the Secretary and Director-in-Chief for the year 1907, also of the Gardener, Curator, Director of Laboratories, Librarian, Honorary Curator, Treasurer and Superintendent of Grounds, expenditures and other interesting information.

The schedule of prizes, annual report and financial statement for 1907 of the National Chrysanthemum Society of England has been received. This society was instituted in 1846, and during its sixty years' existence every leading grower and authority on chrysanthemums has been identified with the organization. Its membership now extends all over the United Kingdom and the remote British Dominions and includes many members in foreign countries.

In the settlement of a seven year street car fight in Cleveland, three cent fare has been established all over the city with universal transfers. The public were granted free car rides all over the city for a period of twenty-four hours to celebrate the event. In recognition of the jollification the J. M. Gasser Company sent out a box of roses to all their city customers with a card bearing the legend: "Free car fare, free roses, with the compliments of your florist." That's good advertising.

PITTSBURG EASTER SHOWS.

An exhibition of spring flowers, which in point of magnitude and excellence is said to be the finest ever seen in Pittsburg, and that is saying a good deal, was a magnet which drew a large crowd to the Schenley Park greenhouses on Easter Monday. Every exhibition held here has something over the previous years. It was estimated that over 25,000 people visited the conservatories on Sunday afternoon, many coming from surrounding towns by excursion trains. This yearly Easter exhibit is justly famous throughout western Pennsylvania and is one of the main features of these magnificent conservatories. Mr. J. W. Jones has this year excelled himself, and has provided a treat which could not be surpassed anywhere. Notwithstanding the somewhat unpropitious weather conditions a continuous stream of people passed through the greenhouses all the afternoon. Bulbous plants are shown by thousands, hyacinths, tulips, narcissi, etc., arranged in solid blocks of color. The arrangement is excellent, displaying a marvelous executive ability on the part of the management in growing plants and arranging for such a mammoth exhibition. Everything shown is creditable, certain features being worthy of special mention, chief amongst which is the rose house, which is gay with a large batch of particularly well-flowered Hybrid Perpetual roses, Cheshunt Hybrid being the favorite. The azalea house is brilliant with color. *Richardia Elliottiana* is used here to good advantage, also *Lilium tenuifolium*, *Staphylea colenica*, *Hippeastrum vittatum* wistarias, *Calceolaria hybrida*, *Cineraria stellata*, *Cannas Florence Vaughan* and *Tarrytown*.

A good effect is obtained on the side benches of the lily house by *Canna Black Beauty*, intermixed with *Lilium Harrisii* edged with *Astilbe Japonica*. Another pleasing effect is obtained by mixing *Nicotiana Sanderas* with *Hydrangea Otaksa*. *Hydrangea rosea*, usually considered difficult, is well grown.

The most pleasing feature of the whole exhibit and one which attracts considerable attention is a house devoted to old-fashioned flowers, amongst which are *Xanthocerus sorbifolia* *fritillaria*, *scillas Muscari botryoides*, *Celsia cretica*, *Dicentra spectabilis*, and many other old favorites, which, judging from the interest they arouse, are not by any means forgotten although seldom seen. In the nepenthes house is quite a creditable display of orchids.

At the A. R. Peacock greenhouses, Supt. T. P. Jenkinson again does himself credit with a wonderfully effective arrangement of bulbous plants, *calceolarias*, flowering crab, *gesnera*, *schizanthus*, etc., in one wing; in another a still more effective display is produced by a judicious blending of colors in such subjects as *Azalea mollis*, *A. indica*, *genistas*, *hydrangeas*, *Primula obconica* and many other things. In a small house, *Hippeastrum vittatum*, *Narcissus poeticus*, *ixias* and *Spirea Queen Alexandra* is used with charming results. This new *spirea*, which by many is considered a questionable acquisition, is counted a good thing here, and certainly shows

MASSACHUSETTS AGRICULTURAL COLLEGE.



The exhibition of flowers and plants at the Massachusetts Agricultural College, Friday, April 24, and Saturday, April 25, was the finest held in this vicinity for several years. The display of carnations was exceptionally good and the College feels deeply indebted to the many growers who cooperated in making this show so successful. The interest shown by the students and townspeople was very gratifying, Wilder Hall being crowded to its capacity during the hours the exhibit was open. At the close of the show Professor White sent the flowers so generously contributed by the growers to the hospitals in the vicinity of Amherst.

The following are the exhibitors and the varieties shown:

F. R. Pierson Company, Tarrytown, N. Y.: *White Enchantress*, *Victory*, *Melody*, *Winsor*, *White Perfection*, *Beacon*.

William Nicholson, Framingham, Mass.: 50 blooms *Afterglow*.

W. A. Manda, South Orange, N. J.: *Pearl Pink*, a new hardy seedling dianthus, also blooms of *Cherokee* and *Green roses*.

Peter Fisher, Ellis, Mass.: *Alma Ward*, *Winsor*, *Snowflake*, *Rose Enchantress*, *Beacon*, *Mrs. Tom Harvey*, *Evangeline*, *White Perfection*, *Mrs. C. W. Ward*, *Enchantress*; also four seedlings under number.

S. J. Goddard, Framingham, Mass.: *Helen Goddard*, *Winsor*, *Victory*, *Britannia*, *White Perfection*, *Octoroon*, *Lady Bountiful*, *Enchantress*.

Patten & Company, Tewkesbury, Mass.: *Helen Goddard*, *Harry Fenn*, *Octoroon*, *Victory*, *Manley*, *Winsor*, *Variegated Lawson*, *Beacon*, *Red Lawson*, *Pink Patten*, *White Lawson*,

itself to advantage. The exhibition remains open evenings until 10 P. M., many people seeing the show by artificial light.

At the H. J. Heinz greenhouses there is a floral display where the individuality of E. S. James, the able superintendent, is manifest. Large azaleas well flowered, lilliums, Dutch bulbs, primulas and many other things are arranged in a somewhat flat but effective style. This is the first spring show at the Heinz greenhouses and was patronized by a number of people on Sunday afternoon and evening.

J. HUTCHINSON.

IMPROVING THE MARGUERITES.

F. W. Fletcher, of Auburndale, Mass., has been making a specialty

White Perfection and *Enchantress*; also eight seedlings under number.

H. H. Rogers, South Sudbury, Mass.: *Mrs. T. W. Lawson*, *Fair Maid*, *Winsor*, *The Queen*, and three seedlings under number.

H. W. Field, Northampton, Mass.: *Viola Sinclair*, *Prosperity*, *Enchantress*, *President Selye* carnations; *Bride*, *Bridesmaid*, *Richmond* and *General MacArthur* roses; pansies, nasturtiums and sweet peas.

J. W. Adams & Company, Springfield, Mass.: *Fifty Prospector*.

Peirce Brothers, Waltham, Mass.: *Mrs. T. W. Lawson*, *Governor Guild* seedlings, *Enchantress*, *Rose-pink Enchantress*, *White Perfection*.

Cottage Gardens Co., Queens, N. Y.: *Mrs. C. W. Ward*, *President*, *Snowflake*, *Beacon*, *Alma Ward* and *Mrs. Harvey*.

A. N. Pierson, Cromwell, Conn.: *Bride*, *Bridesmaid*, *Richmond*, *Mme. Chatenay*, *Killarney* roses.

William Sim, Cliftondale, Mass.: Splendid specimens of sweet peas—*Mrs. William Sim*, *Le Marquis*, *Mrs. F. J. Dolansky*, *Mrs. Alexander Wallace*, *Jack Hunter*, *Christmas Captain*, *Christmas Pink*, *Mrs. W. W. Smalley* and *Florence Denzer*.

Especially admired was a vase of thirty magnificent long-stemmed American Beauties from the Waban Rose Conservatories, *Natick*, Mass.; also *Killarney* and *Richmond*.

The Massachusetts Agricultural College devoted one room to named specimens of decorative foliaged plants.

Friday afternoon, Mr. G. H. Sinclair of Northampton addressed the students of the horticultural seminar on the subject of "The Carnation: Its Culture and Development."

of Marguerites for a number of years and has by constant and patient selection of stock and intensive cultivation improved these flowers in a remarkable degree as to strength of stem and size of flower. We have seen some of his flowers in the market that measured 3 1/2 inches across and with stems nearly 2 feet in length. These were the popular lemon-colored variety. Mr. Fletcher has been trying to cross-fertilize these daisies, *Chrysanthemum frutescens*, for years but has thus far failed to get any seed. He would like to hear from any one who has experimented on the same lines or if anyone has been successful in pollinating any of the varieties. Mr. Fletcher is cutting now from 20,000 to 30,000 flowers.

PLANT FOODS.

If basic slag, bone meal, incinerated bones, etc., are used either in composting, ploughing in or surface application, it is of importance to know what quantity to use, what time they are to remain in the soil and what effect, immediate or future, is desired by their presence. Basic slag is soluble to the extent of 35 per cent. where there is free carbonic dioxide present in the soil water and an application of from 6 to 500 lbs. per acre show the effects of the application for from three to four years. If a quicker or greater result is needed an application in solution and suspension should be given either with clear water or liquid manure, constantly stirring while using. Superphosphate gives a quicker result than basic slag particularly where phosphates are present in the soil which is the case if any of the above have been applied, only it is much more dangerous in the hands of the inexperienced or careless user.

Bone meal used in the same proportion, i. e., 600 to 800 lbs. per acre, if steamed or finely ground is traceable for about two years, yet it is true that the important effect is exhausted in the first few months.

The grower in seeking a soil should try to get a good fibrous loam, or a soil with a good percentage of humus present and one that has also the greatest quantity of natural potash phosphoric acid and organic nitrogen. Any deficiency must be made up artificially, using material that will give dominant active and inactive plant food. I very much prefer using wood ashes for the potash, but do not object to using kainit, as it acts as an animal and vegetable organism destroyer and an accumulator of water; in fact, for this reason I really prefer to use in addition from one to two hundred-weight per acre applying it as a surface dressing after wood ashes have been either ploughed or harrowed in.

Basic slag I always prefer to bone meal or to superphosphate for the phosphoric acid because the bone meal always favors fungus growth and maggots, and the superphosphate readily becomes reconverted to the tricalcic phosphate state.

For nitrogen there is nothing that equals well decayed farm-yard manure, that which has been well made, its potash phosphoric acid and nitrogen conserved, the former two by providing a cesspool to receive the drainage which should be pumped over the manure heap again and again, and the latter by using small quantities of sulphate of iron either in solution or dry state. These applications of sulphate of iron will clean the manure heap of spurious organisms and form with ammonia present in the manure, ammonium sulphate.

I have gone far enough in this article to show it is of the utmost importance to get a soil that has present either naturally or artificially all the essential plant foods, also that they should be present in the three stages of active, dormant and inactive, and further that the soil should be free or rendered free from harmful organism.

GEORGE A. BISHOP.

A. LEUTHY.

Here we have a portrait of one of HORTICULTURE'S staunch friends, one of the pioneers, whose advertisement appeared in the first issue of the paper and has been conspicuous in every issue since that time. Here in Boston we count him as one of our



A. LEUTHY

had working, sagacious and enterprising trade plant growers. He is well known far and wide in this country and also abroad where he has the respect of the large exporting houses resulting from long and honorable business association. Our picture depicts him in a characteristic attitude alert for an order.

PERSONAL.

Robert Gonsalves, florist, of Waltham, Mass., is to be married to Miss Margaret T. Nolan of Newton.

Visitors in Boston: G. C. Eldering, Overveen, Haarlem, Holland; Ed. Roehrs, Rutherford, N. J.; E. J. Fan court, representing Pennock-Moehan Co., Philadelphia, Pa.

F. W. O. Schmitz has been appointed administrator of the affairs on behalf of the children of Fred Bendt and wife of Newark, N. J., both of whom died from typhoid caused by eating oysters.

Alfred Rehder, who had an attack of typhoid fever, is now able to take a short walk daily and hopes to be fully recovered in a short time. Our readers will be glad, we are sure, to welcome him back to the reading columns of HORTICULTURE.

P. Welch, the distinguished wholesale florist of Boston, has been serving on the jury ever since Easter. The effect on his contemporaries is not yet disclosed but a recent conference between this gentleman and Judge Hoitt of Nashua had so much of the cordiality and comradeship of the bar in its make-up that the friends of the first-named gentleman who were accustomed to meet him on even terms when he was simply a wholesale florist are now justified in feeling alarmed over his judicial mien and air of superiority and the future will only disclose the final outcome of this experience as an arbiter of the fates of his fellowmen who have had the misfortune to be haled before the august twelve of which he is one.

INFERIOR DUTCH BULBS.

Editor HORTICULTURE:

Dear Sir:—I heartily agree with the ideas expressed in your editorial on the bulb problem, and I have no doubt that it will have a beneficial effect.

Yours very truly,

PETER REINBERG.

Chicago, Ill.

Editor HORTICULTURE:

Dear Sir:—In reply to yours of recent date asking me how business has been during the past season, now that Easter is over will say that it has not been as good as usual in some respects, but on the whole we will call it a pretty good season.

We have handled the Holland and French bulbs at a great loss. We used to grow about half a million of these bulbs. Last fall we took in only about one-third of our usual supply, and that was one-third too many.

I believe the American people are sick and tired of bulb-stuff and it would do them good if they did not have any for a few years. That might give us a chance to sell more of the other flowers. When the market is glutted with bulb-stuff, it seems to demoralize everything else. I am

Very truly yours,

A. N. PIERSON.

Cromwell, Conn.

Mr. G. C. Eldering, of W. J. Eldering & Son, Overveen, Holland, lays much of the blame for the present plight of the forcing bulb industry in America on his countrymen. He asserts that this country has been made the dumping ground for low grade material for years, and it is not surprising that the American people have become wearied of it.

OBITUARY.

Mrs. Hurn, formerly Miss Sophie Fadden, who for many years conducted a flower store on Bellevue avenue, Newport, R. I., died on Sunday, April 25.

We learn with deep sorrow of the death at Quebec, P. Q., two weeks ago, of that lovable old plantsman, florist and writer, George Moore. We hope to be able to give a more extended notice in next week's issue.

Charles W. Kaber of La Porte, Ind., who since 1894 has carried on a florist's business, died on April 5, aged 75. Mr. Kaber was a native of Germany, but has been in this country since 1853, living in Chicago and South Bend previous to connecting himself with his children in the florist trade at La Porte. A widow and five children survive him.

MAY.

The vales shall laugh in flowers, the woods
Grow misty green with leaping buds,
And violets and windflowers sway
Against the throbbing heart of May.
—Whittier.

You will find something worth reading
on every page of HORTICULTURE.

THE BOSTON VIOLET

The people today are looking for New Violets just as much as they are for new roses or carnations.

THE BOSTON VIOLET

For the past two years has been placed before the most sceptical buyers in America and they prefer it to any other.

THERE'S A REASON

The Boston Violet is the largest, the most fragrant, it has a very pleasing color, and it is a great keeper.

THE BOSTON VIOLET

Is a variety that is early grown, it is the strongest grower and is in crop from September to May.

THE BOSTON VIOLET

Was awarded a First Class Certificate of Merit by the Massachusetts Horticultural Society and a Report of Superior Merit by the Gardeners' and Florists' Club of Boston.

Distribution will Commence in April. Order Now.

PRICES — \$2 per 12 ; \$12 per 100 ; \$100 per 1000.

WILLIAM SIM, : : CLIFTONDALE, MASS.

FOUR BEST ZONAL GERANIUMS.

H. L. Cameron, who has been growing geraniums at North Cambridge for the Boston market for the past twenty-four years and whose stock has high repute, gives as the best varieties for bedding and general use and for out-selling all others, S. A. Nutt dark scarlet, Alphonse Ricard vermilion scarlet, Beaute Poitevine salmon pink, and Mme. Jaulin apple blossom pink. These are all Bruants, semi-double, and although he has a great number of other sorts under cultivation these constitute the great bulk of his stock. Among the newer varieties he mentions Fleuve Blanc, a pure white Bruant of 1905, and Mrs. Lawrence, salmon and white, as likely to take a high position in the list as soon as their splendid qualities for bedding purposes become better known.

English-grown hybrid rhododendrons all the way from 1-2 feet high to 5 feet specimens that have been wintered here without protection for two years are offered by the Eastern Nurseries. See advertisement.

FORGET-ME-NOTS FOR SALE

\$3 per 1000, small plants that will bloom in a month. Can be shipped either by Express or Mail.

WARREN SHINN, - - Woodstown, N. J.

TOWER HOTEL

Niagara Falls, N. Y.

is soliciting your patronage during the S. A. F. Convention.

Very truly yours,

M. J. HOENIG, Prop.

FINEST LOT OF

HARDY HYBRID RHODODENDRONS

ALSO DWARF RHODODENDRONS
ANDROMEDA FLORIBUNDA

READY FOR IMMEDIATE SHIPMENT
ORDER TODAY

EASTERN NURSERIES, JAMAICA PLAIN, MASS.

PLANT IMPORTS.

From Rotterdam: C. C. Abel & Co., 7 cs. bulbs; Cleary's Horticultural Hall, 20 cs. plants; W. Elliott & Sons, 7 cs. trees; R. F. Lang, 7 cs. plants, 2 bales trees; Maltus & Ware, 6 cs. do.; 45 cs. plants, 2 tubs trees; P. Ouwerkerk, 67 cs. do.; Vaughan's Seed Store, 2 bgs. seed; Sundry forwarders, 117 cs. plants; F. & F. Nurseries, 4 cs. do.; Kraemer & Foster, 2 cs. do.; Maltus & Ware, 94 tubs laurel trees, 31 cs. plants; Ter Kuile, 16 tubs laurel trees; A. Walraet, 90 tubs do.; Sundry forwarders, 72 tubs do.; 30 cs. plants.

Via Liverpool: Maltus & Ware, 1 cs. orchids; Wadley & Smythe, 8 cs. trees; To Order, 1 cs. plants.

From Germany: E. L. Boas, 6 cs. plants; E. C. Converse, 1 cs. do.; T. M. Martin, 2 baskets trees; R. F. Lang, 7 pgs. rose bushes; Maltus & Ware, 10 cs. plants; C. F. Meyer, 2 cs. do.; A. Rolker & Sons, 2 cs. do.; Sundry Forwarders, 3 baskets trees.

AUCTION SALES
TUESDAY & FRIDAYS
AT NOON.

CARPET BEDDING, PLANTS, BAY TREES, PALMS, AND BULBS

W. ELLIOTT & SONS

42 Vesey Near Church
NEW YORK, N. Y.

SHRUB CHAT.

Berberis Thunbergii is being used for hedge purposes in enormous quantities in and around Boston. The amount planted this year is far more than that of all other hedge plants combined.

Earliest of all to bloom, while the others are still in small bud, is a variety of *Amelanchier Canadense* with pendulous racemes of pure white flowers, which was found in Vermont. The stems also have a slightly pendulous character.

It now transpires that magnolias, wistarias, early blooming azaleas and similar precocious material suffered disastrously in the severe freeze during Easter week. Wistarias having a north exposure and which had not begun to push out their flower buds were the only ones that escaped in the vicinity of Boston. The flowering dogwoods, which usually succumb to such an experience, appear to have passed through safely.

For a few days past we have been experiencing record weather for April. With the thermometer at July elevation a few hours' time has sufficed to bring vegetation forward to an extent equal to what it would take several days of normal April weather to accomplish and the country is suddenly transformed into verdure and flowers. But it is a dangerous situation, and a sudden cold turn such as is always a possibility at this date, would inflict great damage to flowers and fruit crops.

NEWS NOTES.

The Eastern Nurseries have been given the contract for supplying the trees and shrubs, principally evergreens, for planting the grounds about the Boston Normal and Latin schools.

The red flag denoting the headquarters of the plant auction trade will float no more at 201 Fulton street, but may be found proudly waving every Tuesday and Friday over the entrance to 42 Vesey street, New York, where Wm. Elliott & Sons have fitted up a commodious building with all facilities for receiving and delivering goods and insuring the comfort and convenience of buyers.

RHODODENDRONS

Hardy Hybrids — 1½ ft., 2 ft., 3 ft., 4 ft., 5 ft.

Box — All sizes Bush, Pyramid and Standard.

Roses — Large assortment, Hybrid and Climbing.

Herbaceous Perennials, 1,000 varieties

Send for General Catalog and Trade List

The NEW ENGLAND NURSERIES, Inc.
BEDFORD, MASS.

Hardy Rhododendrons, Azaleas Conifers, Clematis, H. P. Roses, Shrubs and Herbaceous Plants from our **HOLLAND NURSERIES**

Prices Moderate

P. OUWERKERK, 246 1/2 Jane St. Weehawken Heights P. O. No. 1, Hoboken, N. J.

HARDY PERENNIALS

Strong plants in fine condition for immediate effect.
All fresh and thrifty.

Aquilegia Cerulea and *Chrysantha Asclepias Tuberosa*

Bocconia Cordata
Boltonia Asteroides, \$4.00 per 100.

Campanula Carpatica Periclyfolia and *Pyramidalis*, blue and white.

Delphinium Formosum, *Elatum Hybridum* and *Coelestinum*

Dianthus Barbatus, \$4.00 per 100

Dianthus Fraxinella Rubra
Digitalis Gloxiniaeflora, White and Rose

Erianthus Ravennae

Eulalia Gracilis Univata

Eupatorium Coelestinum

Gypsophila Paniculata at \$6.00 per 100

Helianthus Maximilliana

Helianthus Mollis Grandiflora

Heliosis Pithcheriana

Hybicus Crimson Eye, \$3.00 per 100

Oenothera Frazeri, \$6.00 per 100

Poppy Oriental, Bracteata and *Nudicaule*

Pentstemon Barbatus, Torreyi

Platycodon Grandiflorum and *Mariesi*, \$4.00 per 100

Physostegia Virginica

Plumbago Larpenae

Rudbeckia, Golden Glow, \$3.00 per 100

Rudbeckia Purpurea

Salvia Azurea Grandiflora, \$6.00 per 100

Stokesia Cyanea

Tritoma Ilyaria Grandiflora, \$4.00 per 100

Tritoma Pfitzeri \$7.00 per 100, \$60.00 per 1000

Yucca Filamentosa, \$8.00 per 100

Unless noted, \$5.00 per 100.

(For complete list see catalog No. 5).

THE STORRS & HARRISON CO., PAINESVILLE, OHIO

The Leading Horticultural Paper on the Continent

LA TRIBUNE HORTICOLE

PUBLISHED WEEKLY

Official Publication of the Royal Linnean and Flora Societies of Brussels and the National Commission of Pomology of Belgium. Ordered by the Board of Education for the Schools and Scientific Institutions; by the Board of Agriculture and the Board of Justice.

Well Written

Up-to-Date

Splendidly Illustrated

LA TRIBUNE HORTICOLE gives Cultural Information, also all the Gardening News and Full Reports of the Horticultural Meetings and Shows held on the Continent.

12 Water Colored Plates & 40 Half Tone Supplements in each volume

It is the CHEAPEST and best Gardening Paper in Belgium, forming each year a splendid volume of 832 pages of text and 52 SUPPLEMENTARY ILLUSTRATIONS.

LA TRIBUNE HORTICOLE has the Largest Circulation on the Continent, and is the best medium for advertising.

Annual Subscription 8/-, Post Free.

Specimen Copy Post Free on application.

Offices - - - 43, RUE VONCK, BRUSSELS

JOHN WATERER & SON, Ltd.
American Nursery, Bagshot, England

Are Specialists in the

REALLY HARDY VARIETIES

of Rhododendron Hybrids and in Select Varieties of Hardy Border Plants.

LIVE FENCES

We believe we are the largest growers of Hedge plants in America—Privet our specialty—can supply any quantity both

Amoor River and California, strong plants, at \$25.00 per M. Other varieties. Prices on application.

PETER'S NURSERY COMPANY, - Knoxville, Tenn.

AMERICAN NURSERY CO., COMBIN-
ING

FRED'K W. KELSEY, New York City
F. & F NURSERIES, Springfield, N. J.
BLOODGOOD NURSERIES, Flushing, L. I.
N. J. & L. I. NURSERIES

We can supply you every need. Write for prices
Sales Department

150 BROADWAY, - NEW YORK

Berberis Thunbergii

18 to 24-in., 12 to 18-in., all well branched and good roots. 10,000 *Vinca Minor* (Grave Myrtle). 5000 Red Oak, 3 to 5 ft. Norway Spruce, 12 to 18-in.

OAK HILL NURSERIES, Roslindale Mass.

HARDY ROSES FOR THE GARDEN

Strong Field-grown Plants

The roses here offered are extra strong two-year-old field-grown blooming plants, which, if planted early, will give a large number of flowers the first year. They can be planted as early in the spring as the frost is out of the ground, and from that time until about the first week in May. We offer a grand collection of the best and choicest varieties, as follows:

HYBRID PERPETUAL OR JUNE ROSES

Frau Karl Druschki, Marchioness of Londonderry, Capt. Hayward, Mrs. R. G. Sharman-Crawford, Ulrich Brunner, Margaret Dickson, Baron de Bonstetten, Paul Neyron, Gen. Jacqueminot, Magna Charta, Mrs. John Laing, Mme. Gabrielle Luizet, Marshall P. Wilder, Gloire de Paris, Baroness de Rothschild, Prince Camille de Rohan, Fisher Holmes, Alfred Colomb, Soleil d'Or, Persian Yellow, Moss Roses, Rugosa alba and rubra, etc.

MONTHLY AND HYBRID TEA ROSES

Etoile de France, Kiliarney, Mme. Abel Chatenay, Countess of Gosford, Koenigen Carola, Perle von Godesberg, Gruss an Teplitz, Maman Cochet, White Maman Cochet, Belle Siebrecht, Hermosa, Mme. Caroline Testout, Souv. de Pres. Carnot, Kaiserin Augusta Victoria, American Beauty, La France, Clothilde Soupert, Prince de Bulgarie, Mme. Norbert Levavasseur (Baby Rambler), Anny Muller (Pink Baby Rambler), Catherine Ziemet (White Baby Rambler), etc.

In Climbing Roses we have a nice stock of Crimson Rambler, Lady Gay, Dorothy Perkins, Dawson, Gardenia, Tausendschon, etc.

LET US KNOW THE QUANTITY YOU WANT AND VARIETIES, AND WE WILL BE GLAD TO QUOTE LOWEST PRICES ON SAME BY RETURN MAIL.

F. R. PIERSON CO., Tarrytown-on-Hudson, New York

ROSES

100 of the best Hardy sorts.

HYBRID PERPETUALS

Finest English Grown Plants

Dozen, \$3.50; 100 \$25.00

EVERBLOOMING HYBRID TEAS

Bloom from Midsummer until frost.

Dozen \$5.00; 100, \$35.00

Hardy Climbing Roses

All the leading sorts.

Catalogue Free on Application.

R. & J. FARQUHAR & CO.

6 and 7 So. Market Street,
Boston, Mass.

FORESTRY PLANTING

10,000 Red Oak, 4 to 6 in. \$60. Ornamental Planting. Swiss Stone Pine, 3 yrs., 3 to 4 in. \$3 per 100, \$25 per 1000. Foxtail Pine, 3 yrs., 3 to 4 in. \$4 per 100. Bal-four Pine, trans., 4 and 5 in. \$6 per 100. Mugho Pine, trans., 6 to 8 in. \$6 per 100. Compacta Mugho Pine, dwarf, trans., 3 to 4 in., broad \$7 per 100. Hemlock, 6 to 8 in., trans. \$4 per 100. Larger sizes of all of above. Am. Yew, 10 to 12 in., trans. \$16 per 100. Specimen of Caroline Hemlock, Rk Mt Spruce, Rk Mt. Silver Fir, 2 1/2 to 4 ft. \$3 to \$4.
JACKSON'S NURSERIES, Portland, Me.

TAUSENDSCHON

or in English **Thousand Beauties**, is the sensational new Climbing Rose of the year. Every florist should have it. It is not excelled for forcing purposes and for general planting by any Climbing Rose now known, **not even barring Crimson Rambler**. This is the coming forcing Rose. Get your stock early. Illustrated in ten colors and gold in our Catalogue for 1908, the **Leading Rose Catalogue of America**. Every Rose worth having is described in it. Copy free for the asking.

Strong plants of Tausendschon from 3-inch pots,
10 for \$1.50; \$12.00 per 100; \$100.00 per 1000.

THE DINGEE & CONARD CO., WEST GROVE, PA.

HARDY NORTHERN GROWN NURSERY STOCK

At Reasonable Prices

FRUIT AND ORNAMENTAL TREES, SHRUBS, VINES, ROSES AND HERBACEOUS PERENNIALS IN GREAT VARIETY

Catalogue and Price List for the asking

BAY STATE NURSERIES, NORTH ABINGTON, MASS.

NEW ——— NEW

RAMBLER ROSE "NEWPORT FAIRY"

To be disseminated Spring, 1908. Ask for illustrated pamphlet and prices

JULIUS ROEHRS CO., Rutherford, N.J.

The Roses that Win

MRS. POTTER PALMER, CARDINAL American Beauty and Other Standard Varieties. Rooted from Our Famous Stock. Send for Prices.

POEHLMANN BROS. CO.
Morton Grove, Ill.

RHEA REID

READY NOW, Own Root, \$30 per 100, Grafted, \$35 per 100.

AMERICAN BEAUTY

Fine Young Stock, \$6 per 100, \$50 per 1000.

THE E. G. HILL CO., Richmond, Ind.

Seed Trade

Information apparently authentic, is that Louisville has been decided on as the place for the next Canners' Convention, with the Hotel Seelbach as headquarters. It has been customary for the Machinery and Supply men to seek rooms at the headquarters hotel and this has caused some friction, confined mainly to the "bourbons" among the Canners who charge the Machinery and Supply men with pre-empting all of the best rooms. For two years the Machinery and Supply men have discussed the advisability of selecting an independent headquarters, and trying out the question of whether they are really inconveniencing the Canners, but, as in the case of Louisville, many of the towns selected have only one hotel of a class suitable as a headquarters. It was hoped this year that a town might be selected large enough to afford two hotels of sufficient size to make a square test of this issue, but as this has not been done the Canners must endure the presence of their allied association once more.

True to their instincts and traditions, the lawyers have succeeded in delaying a decision as to the future of the Erie Preserving Co. until it is almost too late for them to arrange with the farmers for the growing of the necessary crops to enable them to carry on their business the coming season, although it is only fair to say that it is doubtful if the company can make a showing that will justify the receivers in continuing the business. It is now stated positively that decisive action will be taken not later than the 28th. One result of the delay has been to greatly reduce the value of one of their important assets, namely, their seed, and particularly, peas. The season is now so far advanced that peas will not be wanted in large quantities and varieties which could have readily been sold six weeks ago at \$1 will now go begging at half that price. Space is given to this case because a number of seed growers and seedsmen are creditors of the concern.

In view of the weak vitality of much of the seed corn which will be used this spring, replanting on an extensive scale is quite probable, and particularly if the weather continues wet and cold. As medium early varieties are practically exhausted, especially Crosby's Early, which is a favorite, for "planting in" late sorts will have to be used which will greatly increase the dangers at the end of the season of frost killing or seriously damaging the crop. There is no desire to be pessimistic but these are the conditions that must be faced.

Counter trade is now at high tide east and west, and seedsmen everywhere express themselves as highly gratified with their business up to date. It is unfortunate that the same cannot be said of all other lines, but this great and glorious country cannot be held down long and recovery is certain, albeit somewhat slow.

The committee appointed at the

meeting of seedsmen held in Chicago, April 16th, and others accompanying them who went to Washington to attend the hearing before the Committee on Interstate and Foreign Commerce on April 21st, were granted an informal conference with Mr. Mann on April 20th, and at this conference seem to have made it clear that the bill would need revision before it could be made a just and practicable law. Various changes were urged and most of these were embodied in an amended copy of the bill, which was left with Mr. Mann.

At the public hearing, April 21st the seedsmen's case was fully presented before the Committee on Interstate and Foreign Commerce. Further Congressional action on the bill will be deferred until the next session, thus giving more time for careful consideration of all its features.

It is believed that much good will result from this hearing in the way of a better understanding between seedsmen and the parties having this proposed legislation in charge. It seems reasonably certain that some federal law will be enacted, and it is necessary to the interests of the seed trade that such legislation shall be just and practical. It is impossible at this time to say just what further action may be necessary to safeguard the trade against hasty legislation, or to aid in securing wise and helpful regulation, but this subject will no doubt receive due consideration at the meeting of the American Seed Trade Association at Detroit next June.

Wm. Elliott & Sons are removing from Fulton street to 42 Vesey street, New York, where they have fitted up a very commodious building for their plant auction and seed trade.

Henry F. Michell took title yesterday from Herman W. Fernberger and Oscar J. Bamberger to the five-story building known as Tower Hall, at No. 518 Market street, for a nominal consideration, subject to a \$100,000 mortgage. It stands on a lot 23 by 180 feet and is assessed for \$135,000.—Phila. Record.

CATALOGUES RECEIVED.

George E. Stoddard, Newport, R. I.—Dahlia List, 1908.

Mrs. Bessie M. Rupert, Portland, Me.—Descriptive List of Dahlias.

Wm. F. Turner & Co., New Bedford, Mass.—1908 Catalogue of Dahlias.

J. P. Bodge, Fall River, Mass.—Wynd-Hurst Catalogue of Dahlias.

W. D. Hathaway, New Bedford, Mass.—1908 Catalogue and Price List of Dahlias.

George H. Walker, No. Dighton, Mass.—Descriptive Catalog and Pocket Guide of Dahlias.

J. F. Sullivan, Detroit, Mich.—Illustrated Easter and Spring Announcement. A good idea.

D. R. Long, Buffalo, N. Y.—Easter Souvenir and Display Cards, Folders, etc., for Florists' Use.

Frantz De Laet, Contich, Belgium.—General List of Succulents: text in French, German and American.

Edgar W. Ela, Woburn, Mass.—Dah-

lia Catalogue and Cultural Guide. Finely illustrated and should hit the mark.

F. L. Tinkham, Brockton, Mass.—Catalogue and Price List of Dahlias, Peonies and Hardy Plants, etc., for Spring, 1908.

Rice Brothers, Minneapolis, Minn.—Wholesale Price List of Florists' Supplies: wire designs, flower pots, baskets, labels, greens, etc. Fully illustrated.

George Hollis, South Weymouth, Mass.—Peony Catalog for 1908 and Spring of 1909. Contains portraits of two novelties, Beauty's Mask and Lucy E. Hollis.

W. W. Wilmore, Denver, Colo.—Trade Price List of Dahlias, Gladioli, Peonies and Hardy Plants, for 1908, also Retail Catalogues, illustrated with fine half-tone plates.

W. J. Eldering & Son, Overveen, Haarlem, Holland.—Wholesale List of Dutch Bulbs and Roots; American Edition, 1908. A very complete list, including over 1300 varieties of hardy and tender bulbs.

Foley Manufacturing Company, Western Ave., Chicago, Ill.—1908 Catalogue of Materials for All Kinds of Greenhouse Construction. This comprises a superb series of greenhouse views, diagrams and plans which everyone interested in greenhouse building or equipment can peruse with profit.

The Long Island Railroad Company is issuing some good farm and market garden literature which should do much toward the development of the territory through which their line runs. To an outsider, however, it looks as though much of the good work was nullified by the almost prohibitive rates of fare charged on the road. Think of 28 cents (exclusive of ferry) from New York city to College Point (which is within the city limits), a trip which the trolley cars make for 5 cents.

SURPLUS

Peas and Beans at attractive prices to close out surplus.		
40 bu. Peas, First and Best		at \$2.25
5 " " Alaska		" 4.00
20 " " Gradus		" 4.50
5 " " Nott's Excelsior		" 3.00
5 " " Premium Gem		" 3.00
15 " Beans, Currie's Rust Proof		" 2.50
10 " " Improved Golden Wax		" 2.50
15 " " Burpee's Stringless Green Pod		" 2.50
12 " " Red Valentine		" 2.25
8 " " Refugee		" 2.25
8 " " Wardwell's Kidney Wax		" 2.50
6 " " Mohawk		" 2.25
10 " " Dreer's Bush Lima		" 5.00

Gladioli Bulbs, large No. 1, fine mixture, at \$4.00 per 1000. **Cauliflower plants**, Early Dwarf Erfurt, nice stock, hardened ready for planting, at \$4.00 per 1000. **Cabbage plants**, Early Jersey Wakefield, Early Summer and Large Charleston Wakefield, nice plants, hardened ready for planting, at \$2 per 1000, \$15 per 10,000. **Egg plants**, Black Beauty and New York Improved Spineless, at \$1.00 per 100. **Strawberry plants**, quality collection, 500 plants in five varieties early to late, for \$2.00. **All above quick cash offer.** Mention this paper. Address.

W. F. ALLEN, 102 Market Street, Salisbury, Md.

VEGETABLE PLANTS

CABBAGE Wakefield, L. I. Second Early, Early Flat Out-b, Early Summer, Winingstadt, and other late var. at \$1.00 per 1000, \$8.50 per 10,000.

BEEF Eclipse, Crosby's, Egyptian, at 25c per 100, \$2.25 per 1000.

LETTUCE Boston Market, Tennis Ball, Big Boston Grand Rapids, 20c per 100, \$2 per 1000.

CELERY White Plume, G. S. Blanking, at 20c per 100, \$1.00 per 1000.

Cash with Order.

R. Vincent, Jr. & Sons Co., White Marsh, Md.

Aster Seed!! Have You All You Need??

If you still have an order to send:—DO NOT DELAY, SEND IT TODAY. We are now sold out of our Special Giant Comet. Some of the other varieties are almost sold out. All seed grown by us in 1907.

Aster Book and Competition Card for Great Aster Growing Contest, Free.

ALTIMO CULTURE CO., = CANFIELD, OHIO

*Thorburn's
Seeds*

Seeds of ASPARAGUS PLUMOSUS NANUS, \$2.00 per 1000.

Seeds of ASPARAGUS PLUMOSUS ROBUSTUS, \$2.00 per 1000.

COLD STORAGE LILY OF THE VALLEY PIPS

JAPAN LILIES, JAPAN IRIS

For prices, state quantities required.

J. M. THORBURN & CO.

33 Barclay St., through to 38 Park Place
NEW YORK

Best Quality Fall Bulbs

It is to your advantage to place your order early. Send us a list of your wants and we will quote you rock-bottom prices. Copy of our Florists' Bulb Catalogue will be sent upon request. Catalogues now ready.

VICK'S SUPERB PANSY SEED

All the best varieties in separate colors
VICK'S SUPERB MIXTURE

the best strain from all the leading named sorts
1-8 oz. 75c. 1-4 oz. \$1.50 Ounce \$5.00

JAMES VICK'S SONS, Rochester, N. Y.

PRIMULA, FRINGED SINENSIS

This seed has been grown for us by a specialist in the culture of Primula, and he has produced plants of sturdy growth, large, thick flowers beautifully fringed and carried on erect stems well above the foliage; unexcelled in size, substance and beautiful colors.

Giant Perfection Strain, Finest Mixed, 1-64 oz., \$1.00
Pure White, Brilliant Pink, Blue, Chiswick Red, and
Crimson, 1-64 oz., \$1.00.

H. E. FISKE SEED CO.

13 Faneuil Hall Sq., BOSTON, MASS.

Prices quoted in these columns are for Dealers Only. When writing to Advertisers Please Mention HORTICULTURE.

QUALITY SEED BULBS PLANT
SEND FOR CATALOGUE.
ARTHUR T. BODDINGTON
342 West 14th St., New York.

LANDRETHS' SEEDS

ONION SEED	EXTRA EARLY RED FLAT	LOW PRICES ON APPLICATION
	RED WETHERSFIELD	
	DANVERS GLOBE	
	STRASBURG YELLOW PRIZE TAKER	

BLOOMSDALE SEED FARMS, Bristol, Penna.

G. C. MORSE & CO.

Address all communications to our permanent address
48 to 56 Jackson St., San Francisco, Cal.

The Largest Seed Growers in the United States

BRECK'S SEEDS

For Farmer, Market Gardener and Florist
New Crop High Grade
Catalogues mailed free on application

Joseph Breck & Sons Corp.
47-54 NO. MARKET ST., BOSTON, MASS.

CAULIFLOWERS SEED CABBAGE SEED

HJALMAR HARTMANN & CO.,
12 Stormgade,
COPENHAGEN, DENMARK.

Burpee's Seeds

PHILADELPHIA

Blue List of Wholesale Prices mailed only to those who plant for profit.

BRASLAN SEED GROWERS CO.

GROWERS FOR THE
WHOLESALE TRADE ONLY
SAN JOSE, - - CALIFORNIA

BAMBOO CANES TOUGH AND STRONG

6 ft. long — \$1 per 100; \$6 per 1000; \$11 per 2000

They cost about 10 per cent. more than other kinds, and they are 10 times better.

STUMPP & WALTER CO., - 50 Barclay St., New York

RELIABLE SEEDS

SOW NOW

- Ageratum Mexicanum Blue Star — Tr. Pkt. 25c; 6 Tr. Pkt., \$1.25.
- Lobelia Erinus Pendiculata Hamburgia Tr. Pkt. 30c; 6 Tr. Pkt., \$1.50.
- Primula Obconica Grandiflora — New Hybrids: Blood-red, Blue, Carmine, Pink, Purple, Violet, Pure-white, Compacta, Gigantea, Fringed Mixed Hybrids, each separate, Tr. Pkt. 50c; 6 Tr. Pkts., \$2.50.

My Catalogue will guide you through Reliable Seeds. Ask for Same.

O. V. ZANCEN
SEEDSMAN, HOBOKEN, N. J.

There are some
GOOD BARGAINS
listed in the
BUYERS' DIRECTORY,
Pages 608 to 612 this week.

JUST ARRIVED LARGE SHIPMENT OF High-Grade SCOTCH SOOT.

We have the Stott Double Nozzle
THOMAS J. GREY CO.
32 & 33 So. Market St., BOSTON

BRIDGEMAN'S SEED WAREHOUSE RICKARDS BROS.

Props.
37 East 19th St., - NEW YORK CITY



Mr. FLORIST
Why Don't You Sell
VASES
Every vase sold means more business for you
This Business belongs to you
Will you let us show you how to get it?
Write for Catalogue "B" on VASES
The Kramer Bros. Fdy. Company
DAYTON, O.
Largest Mfg. of Vases in the U. S.

Martial Bremond

WHOLESALE GROWER OF FRENCH BULBS
— OLLIOULES, FRANCE —
A superior quality supplied at market prices. Shipments made direct. Cases marked to order.
Sole Agents
RALPH M. WARD & COMPANY
12 West Broadway - - NEW YORK

CHRYSANTHEMUMS

All the Popular Varieties.
Rooted Cuttings, per 100, \$1.00; per 1000, \$8.00

GERANIUMS

A Large Assortment of the Choicest Kinds.
From 3 1/2 in. pots, \$7.00 and \$8.00 per 100.
FOR DECORATION DAY
40,000 LILIES, \$8.00, \$10.00 and \$12.50 per hundred.
25,000 SPIRAEA (cut), \$2.00 to \$4.00 per hundred.
HYDRANGEAS, 50c to \$5.00 each.
WM. W. EDGAR CO., Waverley, Mass.

Anything of Value to the profession
CAN BE SOLD
through advertising in
Horticulture

HIGH GRADE DUTCH BULBS
W. J. ELDERING & SON
Overveen, Haarlem, Holland
Special Quotations, on large quantities. Wholesale Only.
New York Address **HOTEL SEVILLE**

ROBERT CRAIG CO.
ROSES, PALMS,
and Novelties in Decorative Plants
MARKET and 49th STREETS., PHILADELPHIA, PA.

DAHLIAS. Now is the time to place your order for bulbs which will insure you getting named varieties in any quantity; prompt delivery.
DAVID HERBERT & SON,
Successors to L. K. Peacock, Inc.
ATCO, N.J.

GERANIUMS

Good Strong Stock from 2 inch pots
Centauré, Double Gen'l Grant, El Cid, Miss Kendell, S. A. Nutt, Granville, Jacquerie, Mrs. E. G. Hill, &c., \$2.00 per 100, \$18.50 per 1000.
Alph. Ricard, Berthe de Presilly, Jean de Is Brete, Alice of Vincennes, &c., \$3.00 per 100, \$25.00 per 1000.
Double Dryden, E. H. Trego, Peter Henderson, Telegraph, &c., \$4.00 per 100, \$35.00 per 1000.
Eugene Sue, Mrs Lawrence, Paul Crampel, Mistral, Jean Oberlee, Col. Thomas, &c., \$6.00 per 100, \$50.00 per 1000.
Rose, Nutmeg Oak Leaved and Balm, \$2.00 per 100.
SPECIAL OFFER—We have about 10,000 extra good strong plants, little lots of a kind, the accumulation of the season's odds and ends, single and double, which we offer as long as they last at \$15.00 per 1000, \$8.00 for 500, not less than 500 at this price. **These would make good stock for Decoration Day.**
S. A. Nutt, Double Gen'l Grant, La Pilote, Granville, and other good bedding kinds from 3-in. pots, \$3.50 per 100.
Pelargoniums, in good variety, 3-in pots, \$1.50 per dozen, \$6.00 per 100.

DAHLIA ROOTS Whole field clumps, at \$5.00 per 100 and up; send for list of 75 varieties

HARDY CHRYSANTHEMUMS A splendid collection of the very best 75 varieties, Small Flowered or Button \$2.00 per 100. Large Flowered or Aster type \$3.00 per 100.

DAHLIA PLANTS From 2-in. pots, ready for immediate shipment at \$2.00 per 100 and up. We will send 1000 in 20 good varieties, our selection, for \$8.50.

	Per 100		Per 100
Ageratum, Stella Gurney	\$2 00	Hardy Phlox,	2 00
Begonia, Vernon, White and Rose.....	2 00	Hollyhocks, Strong 3 in. pot plants, dbl. white, pink, red and yellow.....	3 00
" Gracilis, White and Rose.....	2 00	Ivy Leaved Geraniums, 6 good kinds, \$25 00 per 1000	3 00
Begonias "Rex" from 2 in. pots.....	2 00	Lobelia, Crystal Palace Gem	2 00
Cuphaea, Cigar Plant	2 00	" Kathleen Mallard, 2 inch.....	3 00
Coleus, Verschaffeltii, Golden Bedder and other kinds	2 00	Lavender, 2 1/2 in. pots strong	3 00
Fuchsias, Black Prince and Minnesota. Lieutenant Muritz, White and Rose Phenomenal	2 00	Swainsona, Alba	2 00
Hardy English Ivy, Extra Strong. \$15.00 per 1000	2 00	Tradescantia, Dark Variegated.....	2 00
		Verbena, Red, White, Purple and Pink	2 00

R. VINCENT JR. & SONS COMPANY, White Marsh, Md.

AZALEAS for fall delivery, the best that are grown, also **PALMS** for spring or fall delivery, furnished by Belgium; orders booked now.....
AUGUST ROLKER & SONS, 31 Barclay Street, or P. O. Box 752, New York
ADDRESS THE AMERICAN REPRESENTATIVE

CATTLEYA TRIANAE

Just to hand in perfect condition, a large shipment which we offer in cases containing about 40 fine plants aggregating over 450 bulbs, for \$55 per case. Also CATTLEYA LABIATA in cases of 400 bulbs, for \$55 per case. Also ONCIDIUM VARICOSUM ROGERSII, at \$18 per dozen. CATTLEYA MOSSIAE in fine condition in cases of 40 plants, \$55 per case.

LAGER & HURRELL, - - Summit, N. J.

ORCHIDS FOR SALE ORCHIDS

Our entire stock consisting of

3,000 Cattleya Labiata	1,000 Cattleya Schroederiae	1,000 Cattleya Gaskelliana
6,000 Cattleya Trianae	3,000 Cattleya Mossiae	500 Cattleya Speciosissima
	1,000 Cattleya Mendelii	

NO SCALE NO FLY HEALTHY AND VICOROUS ALL SIZES ALL PRICES

Our C. Trianae especilly has been the talk of Orchid men

KOMITSCH & JUNGE, - - Secaucus, N. J.

Large Cape Jasmine Buds (GARDENIA GRANDIFLORA)

FOR THE TRADE:

100 Buds packed in basket, \$1.00 400 Buds packed in box, \$3.50
For larger shipments write for prices. Express Rates on Cape Jasmine Buds very low. Can furnish this year 150,000. Season from May 10th to June 5th.

EHLERS, FLORIST, - HOUSTON, TEXAS

NEPHROLEPIS SCOTTII

in the following sizes, extra good value

25c., 50c., 75c., and \$1
Grand Specimen Plants at \$3, \$4, \$5, \$6.

JOHN SCOTT

Rutland Road and E. 45th St.
Tel. 2890 Bedford **BROOKLYN, N. Y.**

NEP. WHITMANI

2 1/4 in., \$5.00 per 100

NEP. WHITMANI

3 1/2 in., \$25.00 per 100

BOSTON FERNS

2 1/4 in., \$3.00 per 100

H. H. BARROWS & SON Whitman, Mass.

Ipomoea Noctiflora

Best pure white moonvine in market, very fragrant and as big as a saucer. On this variety we have a world-wide reputation as growers and shippers for the last twenty years. Price, 2 1-2 in. pots, \$5.00 per 100. 10,000 are now ready.

CODFREY ASCHMANN,

1012 W. Ontario St., Philadelphia, Pa.

Extra good value in

Decorative Plants

Azaleas, Kentias, Rubbers, Arecas
Araucarias, Pandanus, Box Trees,
Euonymus, Crotons, and
Eurya latifolia.

A Leuthy & Co.

Perkins Street Nurseries, Roslindale, Mass.

Gloire de Lorraine Begonia

2 1/4 inch pots, \$15.00 per 100
\$140.00 per 1000

Thomas Roland

Nahant - - Mass.

HYACINTHS, TULIPS, NARCISSI AND OTHER BULBS

ROMAN HYACINTHS and the true
PAPER WHITE GRANDIFLORA
Ask for our Wholesale Trade List at Hillegom
K. VELTHUYS, Hillegom, Holland
Rep. by FELIX BOSCH, 260 Clarendon St., Boston.

ORCHIDS

Largest Importers, Exporters, Growers and Hybridists in the World

Sander, St. Albans, England
and 235 Broadway, Room 1
NEW YORK CITY

ORCHIDS

Arrived in superb condition, a magnificent consignment of Iten Formosum giganteum, D. Wardianum. These are indeed fine plants. Will arrive April 15, C. labiata, C. Trianae, C. gigas Sanderiana. To arrive about May 1 to 15, C. Mendelii, C. Schroederiae, Mossiae, Gaskelliana, Perivalliana. A trial order will prove we carry the best stock that can be secured.

CARRILLO & BALDWIN, Secaucus, N. J.

Imported Orchids JUST TO HAND

Laelia Purpurata
Cattleya Intermedia
Cattleya Mossiae

JULIUS ROEHRS CO.,

The Orchid Nurseries **RUTHERFORD, N. J.**

ORCHIDS for Spring Delivery

NEW IMPORTATIONS

Cattleyas, Laelias, Oncidiums, etc.

WRITE FOR PRICES

Now is the time to Pot Orchids. Best Quality of Peat, Moss and Baskets on hand.

JOSEPH A. MANDA, 191 Valley Road, WEST ORANGE N. J.

ORCHIDS

The largest importation of Orchids ever received in this country WILL ARRIVE next spring from Brazil, Colombia and Venezuela. If you intend putting in stock wait for these to arrive and we will quote the Lowest Prices in America.

ORDONEZ BROS., - Madison, N. J.

JAPANESE
THE YOKOHAMA NURSERY CO. NEW YORK.
LILIES
PLANTS
BAMBOO STAKES
31 BARCLAY STR.

JOHN BREITMEYER'S SONS

Cor. Miami and Gratiot Aves.
DETROIT, MICH.

Artistic Designs . . .
High Grade Cut Blooms

We cover all Michigan points and good
sections of Ohio, Indiana and Canada

William J. Smyth FLORIST

Cor. Michigan Ave. and 31st St., CHICAGO

We ship to all points in Illinois and Iowa.

Phones: Douglas 744, Douglas 523, Douglas 740

M. C. and J. E. HAUSWIRTH

232 Michigan Ave.
CHICAGO

AUDITORIUM ANNEX Tel. Harrison 585

SAMUEL MURRAY Florist

Coates House Conservatory
1017 BROADWAY, KANSAS CITY, MO
Both 'Phones 2670 Main

FRED C. WEBER FLORIST

4326-28 ST. LOUIS, MO.
OLIVE STREET
Established 1873
Long Distance Phone Bell Lindell 676



WASHINGTON,
D. C.

GUDE'S

Geo. H. Cooke FLORIST

Connecticut Avenue and L Street
WASHINGTON, D. C.

The Park Floral Co.

J. A. VALENTINE
Pres.

DENVER, COLORADO

WILLIAM L. ROCK FLOWER CO.

KANSAS CITY, MO.

will carefully execute orders for Kansas City
and any town in Missouri or Kansas.

Of Interest to Retail Florists.

TWIN CITIES

The Easter trade did not vary much from last year. St. Paul kept the prices up right along, but in Minneapolis some of the department stores and Greek flower dealers began to cut prices as early as Saturday noon. Lilies were cut down to 10 and 15 cts. a blossom, as much as the retailer had to pay for them, yet with very few exceptions the retail florists cleaned up pretty well in spite of the higher prices and the cheap competition. Flower baskets did not sell quite as well this year as they did last. A few stores, but very few, though, overstocked on them, and had considerable material left over.

CHICAGO JOTTINGS.

There is such a thing as having more going on in a florist's store than is desirable even at Easter time. As W. J. Smyth was getting his fine large retail store in Easter garb he was surprised to see an automobile suddenly leave the street and plunge through the window. Every one knows Mr. Smyth is a genial, hospitable man, but he does not want people to enter his store in that way. The damage to the contents of the store was fortunately light, but Mr. Smyth lost the use of one of his immense windows for Easter display.

Rhododendron Pink Pearl, is one of the novelties seen in the Chicago market this year. The immense clusters of large flowers are of the most beautiful shade of pink. It is a distinct improvement over the older varieties and is much admired. The present high price of the imported stock makes it very scarce and the growers have to sometimes place it on the prohibition list on account of the cost. Another fine novelty in Chicago is the pink spirea or Astilbe Queen Alexandra. It is a fine companion for the white Gladstone. When the price gets down closer to a commercial basis there seems to be no question but it will be in great demand.

NEW RETAIL FLOWER STORES.

M. Schmidt, 187 State St., Brooklyn, N. Y.

Fred W. Pape, Park & Grand Aves., St. Louis, Mo.

Clarke & Cook, Fourth St., San Francisco, Calif.

Edward Arnold, 1435 Dorchester Ave., Dorchester, Mass.

Miss Kate Dicks, 429 Shawnee St., Leavenworth, Kan.

Sievers & Jacques, 1628 Van Ness Ave., San Francisco, Calif.

BUSINESS CHANGES.

James Ewings of Elgin, Ill., has taken charge of the rose section of the Miami Floral Co.'s plant, Dayton, Ohio.

Frank W. Ball and Robert A. Betz of Cincinnati, Ohio, have formed a partnership and will carry on the wire design business at 31 East Third street.

Thomas Heskey, Sr., of Grafton, Mass., is to have charge of the C. P. Lewis Greenhouses at Marlboro. Wallace Heskey will conduct the business at Grafton.

Florists Out of Town

Taking orders for delivery in
New York or Vicinity
can have them filled in best
manner and specially delivered
by

Thomas Young, Jr.

500 Fifth Ave., New York City
Telephone 847 Bryant.

ALEX. McCONNELL

571 FIFTH AVENUE
NEW YORK CITY

Telegraphic orders forwarded to any part of the United States, Canada, and all principal cities of Europe. Orders transferred or intrusted by the trade to our selection for delivery on steamships or elsewhere receive special attention.

Telephone Calls, 487 and 488 38th St.
Cable Address, ALEXCONNELL

WILLIAM H. DONOHUE

FLORAL DECORATOR

17 East 28th St., New York

Special Attention to Theatre
and Steamer Orders, and reliable
deliveries guaranteed.

DAVID CLARKE'S SONS

Deliver orders from any part of the country to
New York City

Or OUT-GOING STEAMERS

Write or telegraph

2139-2141 Broadway, New York
Telephone 1552-1553 Columbus

M. A. BOWE

In the Heart of New York City

1294 Broadway

Tel. 2270, 38th St. NEW YORK

Our Motto -- The Golden Rule.

YOUNG & NUGENT

42 West 28 St., NEW YORK

"FLOWERS BY TELEGRAPH"

Flower Deliveries

In Brooklyn and other Long Island Points
New York City, New Jersey, etc. At Theatres,
Hotels, Steamers or Residences.

WILSON

Fulton St. and Greene Ave., Brooklyn, N. Y.

ALBANY, N. Y.

EYRES

Flowers or Design Work

DELIVERED IN ALBANY AND VICINITY
ON TELEGRAPHIC ORDER.

11 NORTH PEARL ST., ALBANY, N. Y.

JACOB SCHULZ, 644 Fourth Ave.,
LOUISVILLE, KY.
Cut Flowers of BEST QUALITY in season
delivered promptly to any address.
Write, Telegraph or Telephone.
Cumberland and Home Phones 223 and 984

PROMPT DELIVERY IN BOSTON

AND ALL NEW ENGLAND POINTS
HOUGHTON & CLARK
396 Boylston St., Boston, Mass.



BOSTON'S BEST
In Quality and Design

Can be relied upon when you transfer your retail orders to

EDWARD MACMULKIN
194 Boylston Street, Boston

Send flower orders for delivery in
BOSTON

and all
NEW ENGLAND POINTS
THOS. F. CALVIN
124 Tremont St., Boston

TRANSFER

Your orders for flower or plant delivery in Eastern New England to

JULIUS A. ZINN,
2 Beacon St., Boston.

Fine Design Work a Specialty

YALE Orders for flower deliveries to Yale College and all other Connecticut points carefully filled and delivered by

J. N. CHAMPION & COMPANY

1026 CHAPEL STREET NEW HAVEN, CONN.

Chicago. Established in 1857

WITTBOLD

FLORIST

1657-1659 Buckingham Place

L. O. Phone 558 Lake View. Send us your retail orders. We have the best facilities in the city.

The Far-Famed Flowers of
TORONTO

Delivered on mail or telegraph order for any occasion, in any part of the Dominion.

JOHN H. DUNLOP,

96 Yonge St., Toronto, Ont.

ATLANTA FLORAL CO.

41 Peachtree Street, ATLANTA, GEORGIA.

KORAL SCRIPT LETTERS AND EMBLEMS

ONCE USED ALWAYS USED
For sale by all first class supply houses. Made by

KORAL MFG. CO.
26 Hawley St., Boston

HART'S HANDY HANDLE

"At Easter-time, with a little chiffon decoration, and the Handle, we were able to increase the value of plants from 50% to 100%."— H. E. WILSON.

Write for descriptive circular and prices

GEO. B. HART, 24 Stone St., Rochester, N. Y.



EVERY FLORIST NEEDS IT
Lewis's Weekly Board File

takes the place of Memo or Order Books, or a line of nails. Just the thing for Sales Slips, Orders to be filled, etc. The Board File is made up of sets of our Spring Spindle File as illustrated herewith. Among the prominent Florists now using it are:

H. H. Ritter, Dayton, O.; W. C. Stickel, Pres. Park St. Flower Market, Boston; Edw. Wood, Pres. Music Hall Flower Market, Boston; J. C. Hatcher, Amsterdam, N. Y.; F. S. Follwell, Pittsfield, Mass.; I. L. Powell, Millbrook, N. Y.; Kensington Flower Shop, Boston; T. F. Galvin, Boston, Mass.

50,000 In Use.

See Large Ad. Horticulture, page 504, April 11, 1908.

A. F. LEWIS MFG. CO., E. Boston, Mass.

A NEW FLOWER MARKET PROPOSED.

We have received from one of the gentlemen interested in the establishment of another co-operative cut flower market in New York city an interesting account of the purposes of this project and what it is proposed to do. The following extracts give the main points touched upon:

"A meeting of the proposed Co-operative Growers' Association was held at the Fruit Auction Company's building April 25th, which was well attended by rose, violet, carnation and other growers, representing over a million feet of glass devoted to cut flower growing, all shippers to New York market. This association is being formed with the object in view of operating a sales-room in New York city, with a competent manager, salesmen, bookkeeper, etc., under the direction of a board of directors elected by its members. Details of incorporation, amount of capitalization etc., are in the hands of a committee which will report at the next meeting.

"It is not the mission of this association to try to fix an arbitrary price on its goods, but by concentration to reduce the cost of selling and in all probability add a supply department. Similar concerns are successfully operated in other lines of business, perishable goods included, and it is claimed that the ability of many of limited capital to combine under efficient management and without incurring liability beyond the amount of their stock subscription has been one of the chief sources of the tremendous growth of this country.

"The next meeting will be held in the same place, Saturday, May the 9th, at 2 P. M. when all cut flower growers for the New York market are invited to attend, but no others will be admitted."

The artistic and useful vases manufactured by the Kramer Foundry Co. are specially adapted for cemetery, park and lawn use. Any florist who carries a line of samples or who has a catalogue at hand can make many profitable sales at this season of the year.

NEWS NOTES.

Maurice L. Belcher, florist, Whitman, Mass., has filed a petition in bankruptcy; liabilities, \$967; assets, \$40.

H. S. Morton has leased the store and greenhouses of the late Alfred Hildred, of Chicago, and will run them in connection with his former business.

J. H. Playdon, Andover, Mass., has secured the contract to supply the flowers for Memorial Day for Gen. W. F. Bartlett Post, G. A. R., of Andover, and Gen. Lawton Post, Lawrence, Mass.

Albert T. Hey, of Springfield, Ill., will become manager of Vaughan's greenhouses at Western Springs, July 1. He takes the place of J. S. Wilson, who will go to Des Moines, Ia., to operate the greenhouses he has recently purchased there.

INCORPORATED.

L. Boehmer & Co., New York city: Bulbs, plants, flowers, etc.; V. L. Outerbridge, E. Morrow, B. J. Tracy; capital, \$25,000.

BOSTON FLORIST LETTER CO.
Manufacturers of FLORISTS' LETTERS

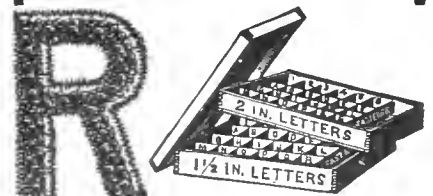

This wooden box nicely stained and varnished, 18x30x12, made in two sections, one for each size letter, given away with first order of 500 letters

Block Letters, 1 1/2 or 2 inch size per 100, \$2.
Script Letters, 3. Fastener with each letter or word. Used by leading florists everywhere and for sale by all wholesale florists and supply dealers

N. F. McCARTHY, Manager
66 Pearl Street, BOSTON, MASS.

GOOD VALUE
**Kaizerins, Brides, Gates,
 Bridesmaid**
 We Have Good Supply of
Cattleyas
The Leo Niessen Company
 1209 Arch St., Philadelphia, Pa.
 Open from 7 a. m. to 8 p. m.

For After Easter Weddings
 CHOICE VALLEY, \$3 and \$4 per 100
 GARDENIAS, \$2.50 and \$3 per doz
 SWEET PEAS, 75c. and \$1 per 100
S. S. PENNOCK - MEEHAN CO.
 1608-1620 Ludlow St. PHILADELPHIA
"The" Wholesale Florists of Philadelphia

EVERYTHING SEASONABLE IN
CUT FLOWERS
 EDWARD REID, Wholesale Florist
 1526 Ranstead St., PHILADELPHIA
 STORE CLOSER 8 P. M.

CHAS. W. MCKELLAR
 51 WABASH AVE., CHICAGO
 Western Headquarters for Choice Orchids
 Valley, Roses and all Cut Flowers

PETER REINBERG
 WHOLESALE
CUT FLOWERS
 51 Wabash Av., Chicago, Ill.

CUT FLOWER BOXES
EDWARDS FOLDING BOX CO
 MANUFACTURERS
 PHILADELPHIA, PA.

AMERICAN BEAUTY and all other
ROSES
LILY OF THE VALLEY, CARNATIONS
WELCH BROS., 226 Devonshire St., Boston, Mass.

SWEET PEAS
 Never better than at present, good
 stem, good color, moderate price.
W. E. MCKISSICK WHOLESALE FLORIST
 PHILADELPHIA
 1619-1621 RANSTEAD ST.

DAILY CONSIGNMENTS
 From 40 to 60 Growers
 We can care for your cutflower wants to
 advantage.
E. F. WINTERSON CO.
 45-47-49 WABASH AVE., CHICAGO

Rice Brothers
 115 N. 6th Street, MINNEAPOLIS, MINN.
WHOLESALE FLORISTS and SUPPLIES
 CUT FLOWERS received twice daily, and can fill
 your orders to your satisfaction. A complete line of
 Hardy Greens - WILD SMILAX, BOXWOOD,
 HARDY FANCY FERNS, GALAX LEAVES.
 Write for quotations on large quantities.

H. BAYERSDORFER & CO.
 The Florists' Supply House
 of America
 Send for Illustrated Catalogue
 1129 ARCH ST., PHILA., PA.

Alex Mann, Jr. Co. Inc.
 Wholesale Dealer in
 Florists' Supplies and Cut Flowers
 White Doves, \$9.00 per doz.
 Galax Leaves.
 1125 Polk Street, San Francisco, Cal.

**WHOLESALE FLOWER MARKETS—TRADE PRICES—Per 100
 TO DEALERS ONLY**

	CHICAGO April 27	TWIN CITIES April 27	PHILA. April 27	BOSTON April 30
ROSES				
Am. Beauty, Fancy and Special...	20.00 to 25.00	40.00 to 50.00	20.00 to 25.00	20.00 to 25.00
" EXTRA.....	12.00 to 15.00	30.00 to 40.00	15.00 to 18.00	12.00 to 15.00
" No. 1.....	6.00 to 12.00	15.00 to 25.00	10.00 to 12.00	6.00 to 10.00
" Lower grades.....	2.00 to 4.00	8.00 to 15.00	2.00 to 4.00	4.00 to 6.00
Bride, 'Maid, Fancy & Special....	6.00 to 8.00	8.00 to	6.00 to 8.00	6.00 to 8.00
" Extra and No. 1.....	4.00 to 6.00	5.00 to	3.00 to 5.00	3.00 to 5.00
" Lower grades.....	2.00 to 3.00	3.00 to	1.00 to 2.00	1.00 to 2.00
Killarney, Richmond, Fan, & Sp...	6.00 to 8.00	5.00 to 8.00	13.00 to 15.00	8.00 to 10.00
" Lower grades.....	2.00 to 3.00	3.00 to 5.00	3.00 to 8.00	2.00 to 6.00
Chat'nay, Wellesley, Fan, & Sp...	6.00 to 8.00	5.00 to 8.00 to	4.00 to 6.00
" Lower grades.....	2.00 to 3.00	3.00 to 5.00 to	1.00 to 3.00
Golden Gate, Ivory..... to 6.00 to to 8.00	1.00 to 6.00
CARNATIONS				
Fancy and Novelties.....	2.00 to 3.00	2.00 to 5.00	2.00 to 3.00	2.00 to 3.00
Ordinary.....	1.00 to 2.00	1.50 to 2.00	1.00 to	1.00 to 2.00
MISCELLANEOUS				
Violets.....	.50 to .75 to to .35	.25 to .50
Cattleyas.....	50.00 to 60.00 to 50.00 to 75.00	50.00 to 60.00
Cypripediums..... to to to	8.00 to 10.00
Lilies.....	6.00 to 8.00	10.00 to 12.00 to 9.00	6.00 to 8.00
Lily of the Valley.....	2.00 to 3.00	3.00 to 4.00	2.00 to 4.00	1.00 to 3.00
Daisies.....	.50 to 1.00	1.00 to 2.00	.50 to .75 to
Daffodils..... to 3.00	2.00 to 2.50	1.00 to 2.00	.50 to 1.00
Tulips.....	2.00 to 4.00	2.00 to 2.50	2.00 to 3.00	.50 to 1.00
Mignonette.....	4.00 to 6.00	4.00 to 5.00	2.00 to 3.00	1.00 to 2.00
Gardenias.....	20.00 to 35.00	30.00 to 40.00 to 15.00	25.00 to 40.00
Lilac per bunch.....	1.00 to 1.50	1.00 to 1.50 to 25.00	.50 to .75
Sweet Peas.....	2.00 to 3.00	.50 to50 to .75	.25 to .50
Adiantum..... to 1.00 to	1.00 to 1.50	1.00 to 1.50
Whitmanii Fronds..... to	1.00 to	2.00 to 3.00	2.00 to 3.00
Smilax.....	12.00 to 15.00	12.00 to 15.00	15.00 to 20.00	10.00 to 12.00
Asparagus Plumosus, strings.....	35.00 to 50.00	35.00 to 50.00 to 50.00	25.00 to 50.00
" " & Spren. (too bchs.)	35.00 to 50.00	35.00 to 50.00 to 50.00	15.00 to 50.00

J. A. BUDLONG
 37-39 Randolph Street, CHICAGO.
 Roses and Carnations WHOLESALE CUT FLOWERS
 A Specialty..... GROWER of

E. A. BEAVEN
 Southern Wild Smilax,
 Log Mosses,
 Natural and Perpetuated — at Wholesale,
 EVERGREEN, ALABAMA.

J. B. Murdoch & Co.
 Wholesale Florists
 FLORISTS' SUPPLIES
 714 Penn Ave., PITTSBURG, PA.
 Long Distance Phone 1435 Court.

FLOWER MARKET REPORTS

BOSTON Things are pretty dull in this market just now; in fact, it may be truthfully said that the grower and wholesale dealer are up against the worst kind of a problem—that of finding an outlet for the tremendous output. The situation looks gloomy from the viewpoint of these people, but from the position of the retail florist it is not so bad, for they can dictate prices on both sides. In other words, they buy at their own price and sell at their own price. And this is the ideal existence for an American tradesman, is it not?

BUFFALO Business showed little activity at end of last week and stock accumulated with prices very much on the decline. A vast amount of material was carried over Sunday in wholesalers' hands. Lily of the valley and greens were the only exception. These cleaned up all right. At present the market is in bad shape, especially on roses and carnations, both of which are coming in faster than they can be handled and bargain signs are again due.

CHICAGO The usual lull succeeding the Easter holiday has struck Chicago with unusual force. While Easter trade as a whole, both in plants and cut flowers, exceeded the most sanguine expectations, it was followed by a week of the greatest supply and the biggest slump the market has known for years. Everything that was not quite ready for Easter, especially Easter lilies and bulbous stock, opened up with the warm weather of Easter day and the first part of the week continuing warm the market was overstocked. Outside flowers came pouring in and did their share in demoralizing trade. A wave of cold weather is following and Chicago market will soon be normal again.

DETROIT Flowers of all kinds are more than can be used and we all have time to turn them into money at the slightest provocation of the purchaser. An unprejudiced perusal of general market conditions ought to satisfy all that nothing is wrong with the flower business although roses, carnations and every other plant cultivated for cut flowers are in full production, while the demand is naturally less than in midwinter. A very encouraging report comes from the real as well as the would-be nurserymen, all of whom report plenty of good orders and are hustling to fill them promptly. A great boom is given this branch of our business through the recently inaugurated civil service league of which I wrote in my last letter. Wm. Dilger is furnishing plans for laying out home gardens, while Frank Danzer treats the same subject in a series of plans showing the same lot as improved with an expenditure of \$2.00, \$5.00, \$10.00 and so on up to \$50.00. Follow this up in your city; it all helps. The people have the money and are willing to spend it. Show them how.

NEW YORK Our price quotations will, upon perusal, tell the story of market conditions as fully as we can in words describe it. The tendency of every-

thing is downward in price and upward in accumulation. There is far more of all kinds of stock than the market can possibly make any use of. Appearances are that the season is over so far as any standard of value for cut flowers is concerned.

PHILADELPHIA Some business last week but prices were 'way, 'way down. Left-over plants of all kinds in hands of retailers had to be pushed wherever possible. Naturally such conditions had their effect on the cut flower business. American Beauty roses cleaned up well but the prices were scandalous. Quality on all roses remains at high water mark—cut heavy. Carnations very satisfactory although some begin to show some stress under the warm weather and prices have dropped. Double violets are still a factor and lily of the valley moves a little better. Far too much of all small stock, such as mignonette, daffodils, daisies, Cattleyas scarce and in good demand. Outdoor shrub bloom sells freely. Good gardenias are in demand but much of the cut is not up to standard. Greens in fair demand with the exception of bunch plumosa.

TWIN CITIES Easter is gone, but most growers are as busy now as they were during or before Easter, for with a very few exceptions they cleaned out everything and are filling up the space again with bedding and spring plants for Decoration Day. All stock grown here was of the very best and plants as well as cut flowers sold at good prices, which did not vary much from last year's figures. Cut flowers brought in from Milwaukee and Chicago were all No. 1 stock. In St. Paul there were a few lilies left over, but Minneapolis made a clean sweep. While there were plenty of roses and carnations, etc., to supply the market, there was a shortage on violets. The beautiful weather, which commenced about ten days before Easter, did its share in the production of perfect stock.

TOLEDO In spite of the bad weather on Saturday before Easter, the business was very satisfactory to everyone. It all came in a rush in the afternoon and continued uninterrupted until Sunday morning. It was a "plant Easter"; everything sold which had a blossom. *Salvia Zarich* proved a fine thing for Easter, several hundred being disposed of. Prices ruled about the same as last year.

NEWS OF TWENTY-EIGHTH ST.

West Twenty-eight street, New York, the centre of the greatest of all wholesale flower districts in the world, is

undergoing a number of changes this spring. It is especially worthy of note that the theatrical and musical interests which have long made this block between Broadway and Sixth avenue a centre for their business are abandoning the locality and moving uptown. This leaves the wholesale florist trade in almost complete possession and the number of vacant premises at present would seem to indicate that the gradual advancement in rents which has been going on for some years has now reached its limit.

From the florists' standpoint the most notable movement is the acquiring of the lease of the large new store at No. 34 and removal thereto by Alex.



ALEX. J. GUTTMAN

J. Guttman. It has been said by a sagacious business man that the real conservative dealer is he who knows when it is time to adopt a new method or take hold and push a new line of goods. Since his advent on 28th street Mr. Guttman has in various ways demonstrated his abilities in this direction and we doubt not his present line of action will be equally successful.

F. S. Hicks & Co. are also making a move from No. 52 to the "parlor floor" at No. 39, following the example of A. H. Langjahr, W. S. Allen, James McManus and others, who have succeeded in drawing business satisfactorily up a flight of steps. The street floor establishments have one great advantage in the open areas in front and in some cases in the rear, but there are now very few street floor stores available and new comers will soon be obliged to go above or else locate in the block west of Sixth avenue where J. K. Allen, Jos. Fenrich and a number of others are already prospering.

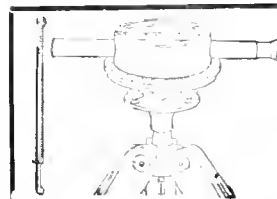

Bostrom Improved Builders' Levels and Farm Levels

For Park, Cemetery and Landscape Gardening use, take the place of expensive Engineering Instruments. Simple in construction, easily adjusted, more substantial and less cumbersome than the more elaborate and complicated instruments. Practical, up-to-date instrument that any one can use. Write for descriptive circulars and be convinced that this Level is necessary to complete your outfit. Builders' Level \$25.00. Farm Level \$12.50.

BOSTROM-BRADY MFG. CO., 139 Madison Avenue., ATLANTA, GA.

JOHN YOUNG
WHOLESALE FLORIST
 Finest American Beauties and
 Carnations
51 West 28 St. - NEW YORK

FORD BROTHERS
 48 West 28th Street, NEW YORK
FINE ROSES FANCY CARNATIONS
 A Full Line of All CUT FLOWERS
 Telephone, 3870 or 3871 Madison Square

H. E. FROMENT,
 Wholesale Commission Florist,
 Choice Cut Flowers,
 57 West 28th St., :: NEW YORK.
 Telephones: 2200, 2201, Madison Square.

The Reliable Commission House
 Richmond Roses and Rich Flowers
 of all varieties
JOS. S. FENRICH
 110 W. 28th Street, New York
 Tel. 324-325 Madison Square

Alfred H. Langjahr
 All choice cut-flowers in season. Send
 for quotations. Correspondence with
 shippers of first-class stock invited.
55 West 28th Street, New York.
 Telephones 4626-4627 Madison Square

JOHN I. RAYNOR
Wholesale Commission Florist SELLING AGENT FOR
 LARGEST GROWERS
 A full line of Choice Cut Flower stock for all purposes. Comprises every variety
 grown for New York market, at current prices
 TEL. 1998 MADISON SQUARE 49 W. 28 St., New York City

Walter F. Sheridan
 Wholesale Commission Dealer in
CHOICE CUT FLOWERS
 39 West 28th Street, New York
 Telephone: 3532-3533 Madison Square

HEADQUARTERS FOR NOVELTIES
ORCHIDS A SPECIALTY
 THE HIGHEST GRADE OF VALLEY ALWAYS ON HAND
 GARDENIAS, DAISIES, ROSES AND CARNATIONS
JAMES McMANUS Telephone 759 Mad. Sq. 42 W. 28th St., New York

PHILIP F. KESSLER 55 & 57 W. 26th St., New York City
 Commission Dealer, Wholesale Buyer
 and Seller of
CUT FLOWERS
 Open from 5 a. m. to 6 p. m. Sunday
 till 10 a. m.
 Tel., 5243 and 2921 Madison Sq. Res., 345 J., Newtown
Finest Lilies in the Market Every Day in the Year.

WHOLESALE COMMISSION FLORIST
J. K. ALLEN 106 W. 28 ST.
 NEW YORK
 Telephone 167
 Madison Sq.
 OPEN 6 A.M. DAILY
 We have a good regular outlet for seasonable flowers

NEW YORK QUOTATIONS PER 100—TO DEALERS ONLY

	Last Half of Week ending April 25 1908	First Half of Week beginning April 27 1908		Last Half of Week ending April 25 1908	First Half of Week beginning April 27 1908
Roses			Cattleyas	40.00 to 60.00	40.00 to 60.00
Am. Beauty, fan and sp.	10.00 to 20.00	10.00 to 20.00	Lilies	2.00 to 5.00	2.00 to 5.00
“ extra	6.00 to 10.00	6.00 to 10.00	Lily of the Valley.....	1.00 to 3.00	1.00 to 3.00
“ No. 1	4.00 to 6.00	4.00 to 6.00	Daisies.....	.25 to 1.00	.25 to 1.00
“ Lower grades	1.00 to 2.00	1.00 to 2.00	Dairoids	1.00 to 1.50	1.00 to 1.50
Bride, 'Maid, fan and sp.	3.00 to 5.00	3.00 to 5.00	Tulips	1.00 to 1.50	1.00 to 1.50
“ extra	1.00 to 3.00	1.00 to 3.00	Nigronette	1.00 to 2.00	1.00 to 2.00
“ lwr. grds.....	.75 to 1.00	.75 to 1.00	Gardenias	10.00 to 25.00	10.00 to 25.00
Killarney, Richmond, fancy & spec	3.00 to 6.00	3.00 to 6.00	Lilac per bunch.....	.15 to .50	.15 to .50
“ lower grades.....	.75 to 2.00	.75 to 2.00	Sweet Peas.....	.20 to .25	.10 to .25
Chatenay, Wellesley, fan. and spec.	3.00 to 5.00	3.00 to 5.00	Adiantum50 to .75	.50 to .75
“ lower grades.....	.75 to 2.00	.75 to 2.00	Smilax.....	10.00 to 15.00	10.00 to 15.00
Golden Gate, Ivory.....	1.00 to 5.00	1.00 to 5.00	Asparagus Plumosus, strings.....	15.00 to 25.00	15.00 to 25.00
Carnations, Fancy and Novelties. .	2.00 to 3.00	1.50 to 2.00	“ “ & Spren. (too bech.)	15.00 to 25.00	15.00 to 25.00
“ Ordinary	1.00 to 1.50	.75 to 1.00			
Violets15 to .40	.15 to .40			

B. S. SLINN, Jr.
 —WHOLESALE FLORIST—
 55 & 57 W. 26th St., New York City
 Tel., 3864 Madison Sq. Shipping Orders Solicited.
VIOLETS Roses and
 Carnations

Edward C. Horan
 Wholesale Florist
 55 WEST 28th ST.
 Tel. 1492
 1463 Madison Square New York

TRAENDLY & SCHENCK
WHOLESALE FLORISTS
 Furnish best stock at fair prices all the year round Send for quotations on all orders
 Tel. 798.799 Madison Sq. 44 West 28th Street, New York City

Alexander J. Guttman
THE WHOLESALE FLORIST OF NEW YORK
 43 WEST 28th STREET
 PHONES. 1664--1665 MADISON SQUARE
ENOUGH SAID



HARDY CUT FERNS

Sphagnum Moss, Extra Large Bales, per bale, \$1.25. Fancy and Dagger Ferns our specialty. A trial order will convince you that we ship only first-class stock. Headquarters for Florists' supplies and wire work. All cut flowers in season. **BOXWOOD**, per bunch 35c, 50 lbs. \$7.50.

MICHIGAN CUT FLOWER EXCHANGE, INC., All 'phone connections 38-40 Broadway, Detroit, Mich.

FANCY and DAGGER
Extra fine, \$1.75 per 1000. Bronze and Green Galax, \$1.25 per 1000. Leucothoe Sprays, \$1.00 per 100, \$7.50 per 1000.

Headquarters in Western New York
FOR
ROSES, CARNATIONS
And all kinds of Seasonable Flowers
Wm. F. Kasting Co.
Wholesale Commission Florist, also Dealer in Florists' Supplies and Wire Designs.
383-87 ELLICOTT ST. BUFFALO, N. Y.
Give us a trial. We can please you.

FRANK S. HICKS & CO.
Wholesale Florists.
Open Now for Consignments of Cut Flowers.
39 West 28th Street, - New York City
Tel. 2920 Mad. Sq.

ROBERT J. DYSART,
Public Accountant and Auditor
Simple methods of correct accounting especially adapted for florists' use.
Books Balanced and Adjusted
Merchants Bank Building
28 STATE ST., - BOSTON
Telephone, Main 38.

HENRY M. ROBINSON & CO.
Wholesale and Commission
FLORISTS
Hardy Cut Evergreens and Florists' Supplies
15 Province St. and 9 Chapman Place,
BOSTON, MASS.

Flowers and Florists' Supplies
The best place in AMERICA to buy
BAY TREES
N. F. McCarthy & Co.
84 Hawley St., BOSTON, MASS.
Largest Dealers in Supplies in New England.

WHOLESALE FLOWER MARKETS. — PER 100. — TO DEALERS ONLY.

	CINCINNATI April 27	DETROIT April 27	BUFFALO April 22	PITTSBURG April 29
ROSES				
Am. Beauty, Fan, and Sp.....	20.00 to 25.00	20.00 to 25.00	30.00 to 35.00	20.00 to 25.00
" Extra	12.00 to 15.00	12.00 to 15.00	20.00 to 30.00	12.00 to 15.00
" No. 1	6.00 to 8.00	6.00 to 12.00	8.00 to 10.00	6.00 to 8.00
" Lower grades..... to 4.00	2.00 to 4.00 to 8.00 to 4.00
Bride, "Maid, F. & S..... to 8.00	6.00 to 8.00	8.00 to 10.00 to 8.00
" Extra	4.00 to 6.00	4.00 to 6.00	6.00 to 8.00	4.00 to 6.00
" Low. gr..... to 2.00	2.00 to 3.00	3.00 to 6.00 to 2.00
Killarney, Richmond, Fan. & Sp..... to 8.00	6.00 to 8.00	8.00 to 10.00 to 8.00
" Lower grades..... to 6.00	2.00 to 3.00	3.00 to 8.00 to 6.00
Chatenay, Wellesley, Fan. & Sp.....	6.00 to 8.00	6.00 to 8.00	8.00 to 10.00	6.00 to 8.00
" Lower grades..... to 4.00	2.00 to 3.00	4.00 to 6.00 to 4.00
Golden Gate, Ivory..... to 6.00 to 6.00	6.00 to 8.00 to 6.00
CARNATIONS				
Fancy and Novelties..... to 2.00	2.00 to 3.00	2.00 to 3.00 to 2.00
Ordinary.....	1.00 to 1.50	1.00 to 2.00	1.50 to 2.00	1.00 to 1.50
MISCELLANEOUS				
Violets..... to .50	50 to .75	.50 to .75 to .50
Cattleyas..... to 75.00	50.00 to 60.00	60.00 to 75.00 to 75.00
Cyripediums..... to 8.00 to 8.00 to 12.00 to 8.00
Lilies.....	6.00 to 8.00	6.00 to 8.00	8.00 to 12.00	6.00 to 8.00
Lily of the Valley.....	2.00 to 4.00	2.00 to 3.00	2.00 to 4.00	2.00 to 4.00
Daisies.....	1.00 to 1.50	50 to 1.00	1.00 to 2.00	1.00 to 1.50
Daffodils.....	1.00 to 2.00 to 3.00	2.00 to 3.00	1.00 to 2.00
Tulips..... to 2.00	2.00 to 4.00	2.00 to 3.00 to 2.00
Mignonette.....	2.00 to 3.00	4.00 to 6.00	2.00 to 4.00	2.00 to 3.00
Gardenias..... to 20.00	20.00 to 35.00	30.00 to 40.00 to 20.00
Lilac per bunch.....	1.50 to 2.00	1.00 to 1.50	1.50 to 2.00	1.50 to 2.00
Sweet Peas.....	.50 to .75	2.00 to 3.00	.40 to .75	.50 to .75
Adiantum..... to 1.25 to 1.00 to 1.00 to 1.25
Whitman's Fronds..... to 15.00	12.00 to 15.00 to 15.00 to 15.00
Smilax.....	30.00 to 50.00	35.00 to 50.00	50.00 to 60.00	30.00 to 50.00
Asparagus Plumosus, striggs.....	30.00 to 50.00	35.00 to 50.00	25.00 to 50.00	30.00 to 50.00
" & Spre. (100 bchs.)	30.00 to 50.00	35.00 to 50.00	25.00 to 50.00	30.00 to 50.00

SAMUEL A. WOODROW
WHOLESALE PLANTSMAN
Palms, Large and Small Ferns, etc.
53 West 30th Street, NEW YORK
Telephone 2083 Madison

WILLIAM H. KUEBLER
Brooklyn's Foremost and Best
WHOLESALE COMMISSION HOUSE
A First Class Market for all CUT FLOWERS
28 Willoughby St., Brooklyn, N. Y.
Tel. 4591 Main

CLEARY'S HORTICULTURAL CO.
Management AMBROSE T. CLEARY
Wholesale Contracting, Jobbing, Auction
HORTICULTURAL PRODUCTS
of every description.
Consignments Received. Surplus Stock Converted.
62 Vesey St., NEW YORK

Moore, Hentz & Nash,
Wholesale Commission Florists,
55 and 57 West 26th Street,
Telephone No. 756
Madison Square. New York.

H. C. BERNING
Wholesale Florist
1402 Pine Street, ST. LOUIS, MO.

MILLANG BROS.
WHOLESALE COMMISSION FLORISTS
41 West 28th Street
Telephone 3860
61 Madison NEW YORK

A. MOLTZ
Will purchase flowers on order in N. Y. market and ship carefully at prevailing wholesale prices. Address
55-57 West 26th Street, New York City

REED & KELLER
122 West 25th St., New York
Florists' Supplies
We manufacture all our Metal Designs, Baskets, Wire Work & Novelties and are dealers in Glassware Decorative Greens and Florists' Requisites.

In writing to Advertisers kindly mention Horticulture

Buyer's Directory and Ready Reference Guide

Advertisements under this head, one cent a word. Initials count as words.

Regular advertisers in this issue are also listed under this classification without charge. Reference to List of Advertisers will indicate the respective pages.

Buyers failing to find what they want in this list will confer a favor by writing us and we will try to put them in communication with reliable dealers.

ACCOUNTANT

R. J. Dysart, 28 State St., Boston.
For page see List of Advertisers.

ALTERNANTHERAS

Red Alternantheras at 40 cents per 100.
C. W. Moeckel, 17 Summer St., Fitchburg, Mass.

ANEMONES

Henry A. Dreer, 714 Chestnut St., Phila.
For page see List of Advertisers.

AQUATIC PLANTS

Aquarium plants the year round. Wholesale and retail. Send for price list. Schml'd's Emporium of Pets, 712 12th Street, Washington, D. C.

ARAUCARIAS

Araucaria excelsa, 6-in., splendid stock, \$9.00 per doz. Holton & Hunkel Co., Milwaukee, Wis.

ASPARAGUS

A. N. Pierson, Cromwell, Conn.
Asparagus Plumosus Seedlings.
For page see List of Advertisers.

J. M. Thornburn & Co., 33 Barclay St., New York.
Plumosus Nanus and P. Robustus.
For page see List of Advertisers.

Asparagus plumosus and Sprenger, 2-in., strong, \$2.25 per 100. J. H. Dann & Son, Westfield, N. Y.

150 Asparagus plumosus nanus, 2½-in., extra fine, 3c.; 300 Pteris Ovarardi, 2½-in., 2c.; heliotropes, 2-in., 2c.; dahlia roots, best varieties, \$2.00 per 100; mixed, \$1.50. Edwin Bishop, Roslyn, Md.

Asparagus Plumosa, 2 in. pots. Fine plants, \$3.00 per 100; \$25.00 per 1000. Cash with order or good reference. Erie Floral Co., Erie, Pa.; or, Wm. F. Kasting Co., 385 Elliott St., Buffalo, N. Y.

ASPARAGUS ROOTS

D. Landreth Seed Co., Bristol, Pa.

ASTER SEED

Altimo Culture Co., Canfield, O.
For page see List of Advertisers.

ASTER SEEDS. All full weight packets fertile 1907 crop. Express—White, Violet, Rose. Trade pkt., 1-16 oz., 25c.; 1-4 oz., 75c.; ounce, \$2.50. Queen of Market—White, Light Pink, Rose, Lavender, Purple. Trade pkt., 1-8 oz., 10c.; 1-4 oz., 15c.; ounce, 50c. Late Branching—White, Pink, Rose, Lavender, Purple. Trade pkt., 1-8 oz., 20c.; 1-4 oz., 30c.; ounce, 50c. Carlson's Branching—Pink, Lavender, Early and Late White. Trade pkt., 1-8 oz., 25c.; 1-4 oz., 40c.; ounce, \$1.25. Kate Lock—White, Daybreak. Same price as Branching. Royal Purple—Trade pkt., 1-16 oz., 35c.; 1-4 oz., \$1.00; ounce, \$3.00. Violet King—Trade pkt., 1-8 oz., 30c.; 1-4 oz., 50c.; ounce, \$1.50. Many other standard sorts in limited quantity. Write if interested. Elmer D. Smith & Co., Adrian, Mich.

AUCTION SALES

Cleary's Horticultural Co., 62 Vesey St., New York.

For page see List of Advertisers.

Wm. Elliott & Sons, 42 Vesey St., New York.

For page see List of Advertisers.

AZALEAS

A. Leuthy & Co., Perkins St. Nurseries, Rosalindale, Mass.

For page see List of Advertisers.

August Rolker & Sons, New York, 31 Barclay St., or P. O. Box 752.

For page see List of Advertisers.

BAMBOO CANES

Stump & Walter Co., 50 Barclay St., New York.

For page see List of Advertisers.

Yokohama Nursery Co., 31 Barclay Street, New York.

For page see List of Advertisers.

BAY TREES.

N. F. McCarthy & Co., 84 Hawley St., Boston.

For page see List of Advertisers.

Bay Trees and Box Trees, standards and pyramids. All sizes. Price list on application. J. Roehrs Co., Rutherford, N. J.

BEDDING PLANTS

R. Vincent, Jr., & Sons Co., White Marsh, Maryland.

For page see List of Advertisers.

A. N. Pierson, Cromwell, Conn.

For page see List of Advertisers.

10,000 geraniums, 10 best standard sorts; 5,000 Vinca variegata; Salvia; heliotrope, dark; feverfew, double white. Good stock, prices right. E. D. Kaulback & Son, Malden, Mass.

BEGONIAS

Thomas Roland, Nahant, Mass.
Gloire De Lorraine.

For page see List of Advertisers.

Begonia Pres. Carnot, 2 1/2 in., \$3.00 100. Valley Greenhouse Co., Sewickley, Pa.

BOILERS

"Burnham" Boilers made for greenhouse heating. Lord & Buroham, 1133 Broadway, N. Y.

BUILDERS' AND FARM LEVELS

Bostrom-Brady Mfg. Co., 139 Madison Ave., Atlanta, Ga.

For page see List of Advertisers.

BUILDING MATERIAL

BUILDING MATERIAL of all description for All Cypress, Semi-Iron, Iron Frame or Truss Houses, Hot Bed Sash and Frames. Lord & Burnham Co., 1133 Broadway, N. Y.

BULBS AND TUBERS

Joseph Breck & Sons, 47-54 N. Market St., Boston.

For page see List of Advertisers.

J. M. Thornburn & Co., 33 Barclay St., New York.

For page see List of Advertisers.

A. T. Boddington, 342 W. 14th St., N. Y.

For page see List of Advertisers.

Rickards Bros., 37 East 19th St., New York.

For page see List of Advertisers.

H. F. Mitchell Co., Philadelphia.

For page see List of Advertisers.

H. E. Fiske Seed Co., Faneuil Hall 8q., Boston.

For page see List of Advertisers.

James Vick's Sons, Rochester, N. Y.
Fall Bulbs.

For page see List of Advertisers.

Aug. Rolker & Sons, 31 Barclay St., New York.

For page see List of Advertisers.

K. Velthuys, Hillegom, Holland,
Represented by Felix Bosch, 260 Clarendon St., Boston.

Bulbs French and Dutch.

For page see List of Advertisers.

Ralph M. Ward & Co., 72 W. Broadway, New York, Agts. for Martial Bremond, Ollioules, France.

For page see List of Advertisers.

Stump & Walter Co., 50 Barclay St., N. Y.
Canna Bulbs.

For page see List of Advertisers.

CANNAS

The Conard & Jones Co., West Grove, Pa.
For page see List of Advertisers.

J. B. Shurtleff & Son, Cushman Ave.,

Revere, Mass.

Live Cannas Started from Sand.

For page see List of Advertisers.

Stump & Walter Co., 50 Barclay St.,

New York.

For page see List of Advertisers.

CARNATIONS

F. Dorner & Sons Co., Lafayette, Ind.
For page see List of Advertisers.

S. S. Skidelsky, 1741 N. 18th St., Philadelphia.

For page see List of Advertisers.

Chicago Carnation Co., Joliet, Ill.

For page see List of Advertisers.

John E. Haines, Bethlehem, Pa.

Carnations Imperial and Plnk Imperial.

For page see List of Advertisers.

Chas. H. Totty, Madison, N. J.

For page see List of Advertisers.

A. N. Pierson, Cromwell, Conn.

For page see List of Advertisers.

H. F. Littlefield, 552 Main St.,

Worcester, Mass.

For page see List of Advertisers.

White Enchantress, unrooted cuttings. Write for prices. Won first prize for best vase of 50. F. H. Westhoff, De Haven, Pa.

Carnation cuttings of all the leading varieties at the same price as any reliable firm. Write for prices before you look elsewhere. Wm. F. Kasting Co., 383

Elliott St., Buffalo, N. Y.

CARNATIONS! FIELD GROWN!!

15,000 Enchantress and Winsor, ready for delivery July 1st. Orders filled in strict rotation. Order now and be first! Prices on application. We guarantee satisfaction. We lead in superb field grown stock.

WANOKA GREENHOUSES,

Barneveld, N. Y.

CAULIFLOWER AND CABBAGE

SEED

H. Hartmann & Co., Copenhagen,

Denmark.

For page see List of Advertisers.

CHRYSANTHEMUMS

Chas. H. Totty, Madison, N. J.
Single Chrysanthemums.

For page see List of Advertisers.

A. N. Pierson, Cromwell, Conn.

For page see List of Advertisers.

Wm. W. Edgar Co., Waverley, Mass.

For page see List of Advertisers.

H. F. Littlefield, 552 Main St., Worcester, Mass.

For page see List of Advertisers.

Rooted Cuttings.

For page see List of Advertisers.

Dr. Enguehard, rooted cuttings, \$9.00 per 1000. Otto Bourdy, Lowell, Mass.

Chrysanthemum rooted cuttings, best varieties; write for list and prices. Edwin Bishop, Roslyn, Md.

Chrysanthemums. 5000 unrooted cuttings of Yellow Bonaffon, 70c. per 100. F. H. Westhoff, De Haven, Pa.

Chrysanthemums—Christmas, Polly Rose, Pacific, Holiday, Nonin and others, \$1.25 per 100. F. P. Sawyer, 125 High St., Clinton, Mass.

Have 100,000 fine young well-rooted Mums, cuttings of the best 60 commercial varieties. Send for our new and low price list. Satisfaction guaranteed. Wm. Ehmann, Jr., Corfu, N. Y.

For List of Advertisers See Page 613

CHRYSANTHEMUMS — Continued

Chrysanthemums ready; 2 1-2 inch strong stock of Tomset, Oct. Frost, Polly Rose, Wanamaker, and all standards, \$3 per 100, \$25 per M. New: 2 1-2, strong, Alice Roosevelt, Hankey, Clay Frick, Winter Cheer, Rosette, B. May, \$5 per 100, \$40 per M. Cash. Send for catalog. Harlowarden Greenhouses, Greenport, N. Y.

COLEUS

A. N. Pierson, Cromwell, Conn.
For page see List of Advertisers.
Coleus Golden Bedder, Verschaffellii, 2 in., \$2.00 100; rooted cuttings, 60c. 100. Valley Greenhouse Co., Sewickley, Pa.

Coleus, Golden Bedder, Verschaffellii, and mixed Coleus, rooted cuttings, 60c. per 100; \$5.00 per 1000. Cash with order. J. E. Felthousen, Florist, Schenectady, N. Y.

CONIFERS

John Waterer & Sons, Ltd., American Nursery, Bagshot, Eng.
For page see List of Advertisers.

CUT FLOWER BOXES.

Edwards Folding Box Co., Philadelphia.
For page see List of Advertisers.
Folding cut flower boxes, the best made. Write for list. Holton & Hunkel Co., Milwaukee, Wis.

CYCLAMEN.

Cyclamen seedlings, fine stock, \$1.50 per 100. Holton & Hunkel Co., Milwaukee, Wis.

DAHLIAS

David Herbert & Son, Atco, N. J.
For page see List of Advertisers.
R. Vincent, Jr. & Sons Co., White Marsh, Maryland.
For page see List of Advertisers.
Dahlia Bulbs, 25 choice named varieties, 1-3 Cactus, for \$1. Catalog free. C. Peirce, Dighton, Mass.

Dahlia, balance of season, 25 named varieties, postpaid, \$1.00. Catalogue free. J. L. Moore, Northboro, Mass.

Dahlia: About 2000 Cath. Duer, Kriemhilde, Brunhilde, Snowdod, etc., \$3 per 100. Cash. Harlowarden Greenhouses, Greenport, N. Y.

Dahlia. Novelties and standard varieties, true to name, a choice list of the best introductions. Send for catalogue of dahlias, hollyhocks, hardy plants, etc. W. W. Wilmore, Box 382, Denver, Colo.

Dahlia Roots—Undivided field clumps, Lydthurst, Maid of Kent, William Agnew, White Swan, Kriemhilde, John Walker, Arbella and A. D. Livoni. Write for low prices. Wood & Healey, Hammoncton, New Jersey.

The East Bridgewater Dahlia Gardens have 50 varieties of up-to-date dahlias to offer in full field clumps just as dug. Over 200,000 clumps. Send to the eastern dahlia king for rock bottom price list. J. K. Alexander, East Bridgewater, Mass.

Cactus, Decorative, Show, Fancy and Pompon Dahlias. 75 leading varieties to select from. Strong divided clumps, in 10 or 20 varieties, my selection at \$3.00 per 100; \$25.00 per 1000. Single Dahlias, mixed, \$1.00 per 100. Cash with order please. Hermann Thlemaun, Monson, Mass.

DECORATIVE PLANTS

A. Leuthy & Co., Perkins St. Nurseries, Roslindale, Mass.
For page see List of Advertisers.

DRACAENAS

Dracaena indivisa, 5-in., perfect plants, 30 to 36 inches high, \$2.50 per doz.; 2 1/2-in., strong seedlings, \$2.00 per 100. Jos. Labo, Joliet, Ill.

ECHEVERIAS

Echeverias, \$15 per 1000, post paid. McDowell, Mexico City.

FERNS

A. Leuthy & Co., Roslindale, Mass.
For page see List of Advertisers.
H. H. Barrows & Son, Whitman, Mass.
Nephrolepis Whitmanii.
For page see List of Advertisers.
John Scott, Brooklyn, N. Y.
For page see List of Advertisers.

FERTILIZERS

Pulverized Manure Co., 31 Union Stock Yards, Chicago, Ill.
Wizard Brand Cattle Manure.
For page see List of Advertisers.
Thos. J. Grey & Co.,
32 and 33 South Market St., Boston.
High-Grade Scotch Soot.
For page see List of Advertisers.

FICUS

Ficus elastica, 5-in., extra fine stock, \$4.00 per doz. Holton & Hunkel Co., Milwaukee, Wis.

FLORAL PHOTOGRAPHS

Floral Photographs. Foley's 226-228 1-2 Bowery, New York.

FLORISTS' LETTERS.

Boston Florist Letter Co., 66 Pearl St., Boston, Mass.
For page see List of Advertisers.
Koral Mfg. Co., 26 Hawley St., Boston.
For page see List of Advertisers.

FLORISTS SUPPLIES

N. F. McCarthy & Co., 84 Hawley St., Boston.
For page see List of Advertisers.
H. M. Robinson & Co., 15 Province St. and 9 Chapman Pl., Boston, Mass.
For page see List of Advertisers.
Keed & Keller, 122 W. 25th St., New York.
For page see List of Advertisers.
The Keivan Co., 113 W. 28th St., N. Y.
Decorative Evergreens.

J. B. Mudoch & Co., 714 Penn Ave., Pittsburg, Pa.
For page see List of Advertisers.
H. Bayersdorfer & Co., 1129 Arch St., Philadelphia.
For page see List of Advertisers.
Alex. Mann, Jr., Co., 1125 Polk St., San Francisco, Calif.
For page see List of Advertisers.

FLOWERS BY TELEGRAPH

Park Floral Co., Denver, Colo.
For page see List of Advertisers.
J. N. Champton & Co., 1026 Chapel St., New Haven, Conn.
For page see List of Advertisers.
George H. Cooke, Washington, D. C.
For page see List of Advertisers.
Gude Bros. Co., 1214 F St., Washington, D. C.
For page see List of Advertisers.
Atlanta Floral Co., Atlanta, Ga.
For page see List of Advertisers.
M. C. & J. E. Hanswirth, 232 Michigan Ave., Chicago.
For page see List of Advertisers.
William J. Smyth, Michigan Ave. and 31st St., Chicago.
For page see List of Advertisers.
George Wittbold Co., 1657-59 Buckingham Place, Chicago.
For page see List of Advertisers.
Jacob Scholz, 644 4th Ave., Louisville, Ky.
For page see List of Advertisers.
Thos F. Galvin, 124 Tremont St., Boston.
For page see List of Advertisers.
Julius A. Zinn, 2 Beacon St., Boston.
For page see List of Advertisers.
Houghton & Clark, 396 Boylston St., Boston.
For page see List of Advertisers.
Sidney Hoffman, 59-61 Massachusetts Ave., Boston.
For page see List of Advertisers.
Edward MacMullin, 194 Boylston St., Boston.
For page see List of Advertisers.
J. Breitmeyer's Sons, Miami and Gratiot Aves., Detroit, Mich.
For page see List of Advertisers.
Samuel Murray, 1017 Broadway, Kansas City, Mo.
For page see List of Advertisers.
Wm. L. Rock Flower Co., 1116 Walnut St., Kansas City, Mo.
For page see List of Advertisers.
Fred C. Weber, 4326-28 Olive St., St. Louis, Mo.
For page see List of Advertisers.
H. G. Eyres, 11 N. Pearl St., Albany, N. Y.
For page see List of Advertisers.

FLOWERS BY TELEGRAPH — Continued

David Clarke's Sons, 2159-2141 Broadway, New York.
For page see List of Advertisers.
W. H. Donohoe, 17 E. 28th St., New York.
For page see List of Advertisers.
Alex. McConnell, New York.
For page see List of Advertisers.
M. A. Bove, 1204 Broadway, New York.
For page see List of Advertisers.
Robert G. Wilson, Fulton St. & Greene Av., Brooklyn, N. Y.
For page see List of Advertisers.
Thomas Young, Jr., 500 Fifth Ave., N. Y.
For page see List of Advertisers.
Young & Nugent, 42 W. 28th St., N. Y.
For page see List of Advertisers.
J. H. Dunlop, 96 Yonge St., Toronto, Can.
For page see List of Advertisers.

FLOWER POTS

W. H. Ernest, 28th and M Sts., Washington, D. C.
For page see List of Advertisers.
A. H. Hews & Co., Cambridge, Mass.
For page see List of Advertisers.
Hillinger Bros., Ft. Edward, N. Y.
For page see List of Advertisers.
Red pots, seed pans, etc.
The Peters & Reed Pottery Co., Zanesville, O.

FORESTRY AND ORNAMENTAL PLANTING

Jackson's Nurseries, Portland, Me.
For page see List of Advertisers.

FUCHSIAS

Fuchsias, finest mixed, 2 in., \$2.50 per 100; rooted cuttings, \$1.00. Valley Greenhouse Co., Sewickley, Pa.

GALAX

Michigan Cut Flower Co., 38 and 40 Broadway, Detroit, Mich.
For page see List of Advertisers.

GARDEN VASES

Kramer Bros. Foundry Co., Dayton, O.
For page see List of Advertisers.

GERANIUMS

R. Vincent Jr. & Sons Co., White Marsh, Md.
New and Standard Varieties.
For page see List of Advertisers.
Wm. W. Edgar Co., Waverley, Mass.
For page see List of Advertisers.
Geraniums, 2 in., double red, \$1.50 per 100. J. H. Dunn & Son, Westfield, N. Y.

GLADIOLI

Arthur Cowee, Meadowvale Farm, Berlin, New York.
For page see List of Advertisers.
I. & J. L. Leonard, Iona, N. J.
Gladiolus Bulbs.
For page see List of Advertisers.
Gladioli. Write for leaflet. B. Hammond Tracy, Cedar Acres, Wenham, Mass.
Gladiolus, large flowering mixed, balance of season, \$1.00 per 100; postpaid. J. L. Moore, Northboro, Mass.

Gladiolus Bulbs and hand hybridized seed. Newest. Best. Circular free. B. F. White, Terryville, Conn.

GLASS

Boston Plate & Window Glass Co., Boston.
For page see List of Advertisers.
Standard Plate Glass Co., 26-30 Sudbury St., Boston.
For page see List of Advertisers.
S. Jacobs & Sons, 1365-79 Flushing Ave., Brooklyn, N. Y.
For page see List of Advertisers.
Metropolitan Material Co., 1398-1408 Metropolitan Ave., Brooklyn, N. Y.
Foley Mfg. Co., Western Ave., between 25th & 26th Sts., Chicago.
Greenhouse glass, lowest prices. Johnston Glass Co., Hartford City, Ind.
GLASS, High Grade, Double Thick Greenhouse Glass. Lord & Burnham, 1133 Broadway, N. Y.

In writing to Advertisers kindly mention Horticulture

GLAZING POINT

H. A. Dreer, Philadelphia, Pa.
For page see List of Advertisers.

GLAZING POINTS, Lord & Burnham
Special Glazing Nails (Points). Lord &
Burnham, 1133 Broadway, N. Y.

GREENHOUSE BUILDING MATERIAL

Lord & Burnham Co.,
1133 Broadway, New York.

For page see List of Advertisers.

Pierson U-Bar Co., 1 Madison Sq., N. Y.
For page see List of Advertisers.

A. T. Stearns Lumber Co., Neponset,
Boston.

For page see List of Advertisers.

Klug Construction Co., N. Tonawanda,
New York.

For page see List of Advertisers.

J. C. Moninger Co., 117 East Blackhawk St.,
Chicago, Ill.

For page see List of Advertisers.

Foley Mfg. Co., Western Ave., between
25th & 26th Sts., Chicago.

For page see List of Advertisers.

I. Casaldi, Summer Ave. and Erie R. R.,
Newark, N. J.

For page see List of Advertisers.

Geo. B. Doane, 18 Midway St., Boston.
Iron Pipe.

For page see List of Advertisers.

S. Jacobs & Sons, 1365-79 Flushing Ave.,
Brooklyn, N. Y.

For page see List of Advertisers.

Metropolitan Material Co., 1398-1408 Metro
politan Ave., Brooklyn, N. Y.

GREENHOUSE CONSTRUCTION

GREENHOUSE CONSTRUCTION, Semi-
Iron Greenhouse, New Truss Houses and
Iron Frame Houses. Lord & Burnham,
1133 Broadway, N. Y.

J. A. Payne, 260-274 Culver Ave., Jersey
City, N. J.

For page see List of Advertisers.

I. Casaldi, Summer Ave. and Erie R. R.,
Newark, N. J.

For page see List of Advertisers.

Foley Mfg. Co., Western Ave., between
25th & 26th Sts., Chicago.

For page see List of Advertisers.

GUTTERS

GUTTERS, Cast Iron Gutters, L. & B.
Improved V Shaped Gutter with drip gutter
attachment. Lord & Burnham, 1133
Broadway, N. Y.

HAIL INSURANCE

Florists' Hall Assn. of America.
J. G. Esler, Saddle River, N. J.
For page see List of Advertisers.

HARDY FERNS AND SUPPLIES

H. M. Robinson & Co., 15 Province St.
and 9 Chapman Pl., Boston, Mass.

For page see List of Advertisers.

Michigan Cut Flower Exchange,
88 and 40 Broadway, Detroit, Mich.
Fancy Ferns.

For page see List of Advertisers.

The Kervan Co., 112 W. 28th St., N. Y.

HARDY PERENNIALS

The Storrs & Harrison Co., Painesville, O.
For page see List of Advertisers.

HARDY PLANTS

Lobelia cardinalis, large clumps, \$1.50
per doz., \$8.00 per 100. Gentiana Andrewall
and linearis, in clumps, \$1.50 per doz., \$8.00
per 100. Native ferns, trees and shrubs at
prices to suit. A fine lot of nursery grown
White Pine, Hemlock, Fir Balsam, Norway
and White Spruce of various sizes at re-
duced prices. L. E. Williams, Nottingham,
N. H.

HART'S HANDY HANDLE

Geo. B. Hart, 24 Stone St., Rochester, N. Y.
For page see List of Advertisers.

HEATING APPARATUS

Lord & Burnham Co.,
1133 Broadway, New York.

For page see List of Advertisers.

Pierson U-Bar Co., 1 Madison Sq., N. Y.
For page see List of Advertisers.

John A. Payne, 260-274 Culver Ave., Jersey
City, N. J.

For page see List of Advertisers.

HEDGE PLANTS

Peter's Nursery, Knoxville, Tenn.
For page see List of Advertisers.

Morris Nursery Co., 1 Madison Ave.,
New York.

HELIOPTROPES.

Heliotropes, 2-in., 2c.; rooted cuttings,
from soil. 75c. per 100. Edwin Bishop,
Roslyn, Md.

Heliotropes, 2 in., \$2.50 100; rooted cut-
tings, \$1.00 100. Valley Greenhouse Co.,
Sewickley, Pa.

HELP FURNISHED

Thos. H. Bambrick, 34 S. 7th St., Phila.
For page see List of Advertisers.

HERBACEOUS PERENNIALS

Red Oak Nurseries, Flakeville, R. I.
For page see List of Advertisers.

Bay State Nurseries, No. Abington, Mass.
For page see List of Advertisers.

New England Nurseries, Inc.,
Bedford, Mass.

For page see List of Advertisers.

P. Ouwkerk, P. O. No. 2, Hoboken, N. J.
For page see List of Advertisers.

HOLLYHOCKS

Hollyhocks, separate colors, field grown,
healthy stock, \$3.00 per 100; also Dahlias,
novelties and standard varieties. Send for
catalogue. W. W. Willmore, Box 382, Den-
ver, Colo.

HOSE

Frank L. Moore, Chatham, N. J.
Sunnyside Hose.

HOT-BED SASH

The A. T. Stearns Lumber Co., Neponset,
Mass.

For page see List of Advertisers.

Pierson U-Bar Co., 1 Madison Sq., N. Y.
For page see List of Advertisers.

Lord & Burnham Co., 1133 Broadway, N. Y.
For page see List of Advertisers.

Foley Mfg. Co., Western Ave., between
25th & 26th Sts., Chicago.

HYDRANGEAS.**HYDRANGEAS PANICULATA.**

Grandiflora, 18-in. to 24-in., \$5.00 per 100.
Grandiflora, 2 ft. to 3 ft., \$7.00 per 100.
Grandiflora, 3 ft., \$8.00 per 100.

J. H. Danu & Son, Westfield, N. Y.

INSECTICIDES.

Nicotinide kills all greenhouse pests.

P. R. Palethorpe Co.,
Eleventh St., Owensboro, Ky.
For page see List of Advertisers.

IRISES

J. M. Thorburn & Co., 33 Barclay St.,
New York.

For page see List of Advertisers.

Henry A. Dreer, 714 Chestnut St., Phila.
For page see List of Advertisers.

JAPANESE PLANTS

Yokohama Nursery Co., 31 Barclay St.,
New York.

For page see List of Advertisers.

JUMPING BEANS

Jumping Beans, \$5 per 1000, post paid.
McDowell, Mexico City.

KENTIAS

A. Leathy & Co., Roslindale, Mass.
For page see List of Advertisers.

LAWN VASES

Kramer Bros. Fdy. Co., Dayton, Ohio.
For page see List of Advertisers.

LOBELIAS

Lobelia Crystal Palace compacta, strong,
lushy plants, 2-in., \$2.00 per 100. N. E.
Beck, Massillon, O.

MASTICA

E. O. Pierce Co., 12 W. Broadway,
New York.

For page see List of Advertisers.

MOON VINES

Godfrey Aschmann, 1012 W. Ontario St.,
Philadelphia.

For page see List of Advertisers.

Moon vines, fine strong plants, 3 in.,
\$1.00 per 100. Edwin Bishop, Roslyn, Md.

NEW AND RARE PLANTS

Rose Hill Nurseries, New Rochelle, N. Y.
For page see List of Advertisers.

NICO-FUME

Kentucky Tobacco Product Co.,
Louisville, Ky.

NURSERY STOCK

John Waterer & Sons, Ltd.,
American Nursery, Bagshot, England.

For page see List of Advertisers.

New England Nurseries, Bedford, Mass.
Shrubs, Roses and Herbaceous Perennials.
Specimen Pyramidal Box.

For page see List of Advertisers.

Bay State Nurseries, N. Abington, Mass.
Herbaceous Perennials, Hardy Ornamental
Trees.

For page see List of Advertisers.

Cleary's Horticultural Co., 62 Vesey St.,
New York.

For page see List of Advertisers.

P. Ouwkerk, 216 Jane St., Weehawken
Helghts, N. J.

For page see List of Advertisers.

Holland Nursery Stock for Forcing.

For page see List of Advertisers.

American Nursery Co., 150 Broadway, New
York, N. Y.

For page see List of Advertisers.

I. & J. L. Leonard, Iowa, N. J.
California Privet, American Ceanothus.

For page see List of Advertisers.

Peter's Nursery Co., Knoxville, Tenn.
Live Fences; Amoor and California Privet.

For page see List of Advertisers.

Jackson's Nurseries, Portland, Me.
For page see List of Advertisers.

F. E. Conine Nursery Co., Stratford, Conn.
The Morris Nursery Co.,
Sales Office, 1 Madison Ave., New York.
Ornamental Trees, Evergreens, Hedge
Plants.

ORCHID PLANTS

Lager & Hurrell, Summit, N. J.
For page see List of Advertisers.

Sander, St. Albans, England.
Importers, Exporters, Growers, Hybridists
For page see List of Advertisers.

Jullus Roehrs Co., Rutherford, N. J.
For page see List of Advertisers.

Carrillo & Baldwin, Secaucus, N. J.
For page see List of Advertisers.

Joe. A. Manda, 191 Valley Road, W.
Orange, N. J.

For page see List of Advertisers.

Ordonez Bros., Madison, N. J., Box 105.
For page see List of Advertisers.

PALMS

A. Leathy & Co., Perkins St. Nurseries,
Roslindale, Mass.

For page see List of Advertisers.

Robert Craig Co., Market and 49th Sts.,
Philadelphia, Pa.

For page see List of Advertisers.

August Rolker & Sons, 31 Barclay St.,
New York.

For page see List of Advertisers.

Kentia, Phoenix, etc., all sizes. Write
for new price list. Jullus Roehrs Co.,
Rutherford, N. J.

PAINT AND PUTTY

PAINT AND PUTTY: Ideal Greenhouse
lead; Special Greenhouse Putty. Lord &
Burnham, 1133 Broadway, N. Y.

PANSY PLANTS.

Pansies, a mixture of the finest strains
of exhibition stock obtainable in Germany
and America. Seed bought direct from the
growers. Good, strong, frame-grown plants,
75c. per 100; \$6.00 per 1000. N. E. Beck,
Massillon, O.

PATENTS

Siggers & Siggers, Washington, D. C.
For page see List of Advertisers.

PEAT

Orchid peat, Rotted peat, Azalea peat,
Leaf-Mould, Live Sphagnum moss, Baled
Sphagnum moss, Green Clamp moss, etc.
Jobbers' list on application. C. W. Brown-
ell & Co., Walden, N. Y.

PELARGONIUMS

R. Vincent, Jr. & Sons Co., White Marsh,
Maryland.

For page see List of Advertisers.

For List of Advertisers See Page 613

PEONIES

Wholesale Peony list for fall 1908 is now ready. J. F. Rosenfield, West Point, Neb.
One of the finest collections in America. Send 25 cts. in stamps for new edition of Peony Manual. C. S. Harrison's Select Nursery, York, Neb.

PHLOXES

Henry A. Dreer, 714 Chestnut St., Phila.
For page see List of Advertisers.
Send 25 cts. in stamps for Phlox Manual. Fine mixed phloxes \$1.50 per 100. C. S. Harrison's Select Nursery, York, Neb.

PIPE AND FITTINGS

Foley Mfg. Co., between Western Ave. and 26th St., Chicago, Ill.
Eagle Metal & Supply Co., Johnson and Union Aves., Brooklyn, N. Y.
Second-Hand Pipe and Boiler Tubes.
For page see List of Advertisers.
PIPE AND FITTINGS. Cast Iron and Wrought Pipe, Valves, Elbows, Pipe Hooks, Automatic Air Headers, etc. Lord & Burnham, 1133 Broadway, N. Y.

PLANT STAKES AND TRELLISES

Seele's Patent, for roses, chrysanthemums, gladioli, tuberoses, dahlias tomatoes, egg plants, etc. H. D. Seele & Sons, Manuf., Elkhart, Ind.

PLANT TUBS

Keystone Cedar Plant Tubs.
Henry A. Dreer, 714 Chestnut St., Phila.
For page see List of Advertisers.

POT HANGERS

Pot hangers, Kramer's \$1 doz. by exp., \$1.25 by mail. I. N. Kramer & Son, Cedar Rapids, Ia.

PRIMULAS

Primula obconica, famous Rousdorf & Lattmann strains. Large flowering blue, blood red, 40c. 1-2; 75c. tr. pkt. Carmine, lilac, dark eyed, rose, white, mixed, fringed lilac, white, mixed, 30c. 1-2, 50c. tr. pkt. P. Obs. Gigantea, originator's strain: Lilac, rose, mixed, 40c. 1-2, 75c. tr. pkt. Carmine, 40c. red, 25c. pkt. Primula Chinensis, from the best specialist. Fringed blue, double mixed, 60c. 1-2, \$1.00 tr. pkt. Blood red, carmine, marbled, rose, striped, white, mixed, 40c. 1-2, 75c. tr. pkt. J. L. Schiller, 929 Prouty Av., Toledo, O.

PRIMULA SEED

A. T. Boddington, 342 W. 14th St., New York.
For page see List of Advertisers.
H. E. Fiske Seed Co., 13 Faneuil Hall Sq., Boston.
For page see List of Advertisers.
O. V. Zangen, Hoboken, N. J.
For page see List of Advertisers.

RAFFIA

Raffia (colored), 20 beautiful shades. Samples free. R. H. Comey Co., Camden, N. J.; 810 Washburn Ave., Chicago, Ill.

RETAIL FLORISTS

Park Floral Co., Denver, Colo.
For page see List of Advertisers.
George H. Cooke, Washington, D. C.
For page see List of Advertisers.
Gnde Bros. Co., 1214 F St., Washington, D. C.
For page see List of Advertisers.
Atlanta Floral Co., Atlanta, Ga.
For page see List of Advertisers.
M. C. & J. E. Hauswirth, 232 Michigan Ave., Chicago.
For page see List of Advertisers.
William J. Smyth, Michigan Ave. and 31st St., Chicago.
For page see List of Advertisers.
George Wittbold Co., 1637-59 Buckingham Place, Chicago.
For page see List of Advertisers.
Jacob Schulz, 644 4th Ave., Louisville, Ky.
For page see List of Advertisers.
Thos. F. Galvin, 124 Tremont St., Boston.
For page see List of Advertisers.
Julius A. Zinn, 2 Beacon St., Boston.
For page see List of Advertisers.
Houghton & Clark, 396 Boylston St., Boston.
For page see List of Advertisers.

RETAIL FLORISTS - Continued

Sidney Hoffman, 59-61 Massachusetts Ave., Boston.
For page see List of Advertisers.
Edward MacMulkh, 194 Boylston St., Boston.
For page see List of Advertisers.
J. Breitmeyer's Sons, Detroit, Mich.
For page see List of Advertisers.
Samuel Murray, 1017 Broadway, Kansas City, Mo.
For page see List of Advertisers.
Wm. L. Rock Flower Co., 1116 Walnut St., Kansas City, Mo.
For page see List of Advertisers.
Fred C. Weber, 4326 Olive St., St. Louis, Mo.
For page see List of Advertisers.
J. N. Champlin & Co., 1026 Chapel St., New Haven, Conn.
For page see List of Advertisers.
H. G. Eyres, 11 N. Pearl St., Albany, N. Y.
For page see List of Advertisers.
David Clarke's Sons, 2139-2141 Broadway, New York.
For page see List of Advertisers.
W. H. Donohoe, 17 E. 28th St., New York.
For page see List of Advertisers.
Alex. McConnell, New York.
For page see List of Advertisers.
M. A. Bowe, 1204 Broadway, New York.
For page see List of Advertisers.
Robert O. Wilson, Fulton St. and Greene Ave., Brooklyn, N. Y.
For page see List of Advertisers.
Thomas Young, Jr., 500 Fifth Ave., N. Y.
For page see List of Advertisers.
Young & Nugent, 42 W. 28th St., N. Y.
For page see List of Advertisers.
J. H. Dunlop, 96 Yonge St., Toronto, Can.
For page see List of Advertisers.

RHODODENDRONS

John Waterer & Sons, Ltd., American Nursery, Bagshot, England.
For page see List of Advertisers.
P. Ouwerkerk, Hoboken, N. J.
For page see List of Advertisers.
New England Nurseries, Bedford, Mass.
For page see List of Advertisers.
Morris Nursery Co., 1 Madison Ave., New York.

ROSES

Julius Roehrs Co., Rutherford, N. J.
Rambler Rose, Newport Falry.
For page see List of Advertisers.
New England Nurseries, Inc., Bedford, Mass.
For page see List of Advertisers.
Bay State Nurseries, N. Abington, Mass.
For page see List of Advertisers.
Robert Craig Co., Market and 40th Sts., Philadelphia, Pa.
For page see List of Advertisers.
Dingee-Conard Co., West Grove, Pa.
New Climbing Rose, Tausendschon.
For page see List of Advertisers.
F. R. Pierson Co., Tarrytown-on-Hudson, N. Y.
Hardy Roses for the Garden.
For page see List of Advertisers.
R. & J. Farquhar & Co., 6 and 7 South Market Street, Boston.
For page see List of Advertisers.
The E. G. Hill Co., Richmond, Ind.
Roses, Rhea Reid, American Beauty.
For page see List of Advertisers.
Poehlmann Bros. Co., Morton Grove, Ill.
Mrs. Potter Palmer, Cardinal Beauty.
For page see List of Advertisers.
P. Ouwerkerk, P. O. No. 2, Hoboken, N. J.
For page see List of Advertisers.
Chas. H. Totty, Madison, N. J.
For page see List of Advertisers.
Morris Nursery Co., 1 Madison Ave., New York.
400 varieties; own roots; summer grown. Leedle Company, Springfield, Ohio.
Roses, Mald, Bride, Chatenay, Gate, 2 in., \$3.00 100. Valley Greenhouse Co., Sewickley, Pa.
Crimson Ramblers, 2 year, on own roots, extra strong, at 7 cents. Gilbert Costich, Rochester, N. Y.

ROSES - Continued

Low-budded roses, No. 1, \$95.00; No. 11-2, \$65.00 1000. H. T. Jones, Ellizabeth, N. J.
The beautiful new pink rose, MISS KATE MOULTON is the queen of all pink roses. It's a winner and you should grow it. Price \$30.00 100; 500 \$125.00; 1000 \$200.00; 5000 and upwards \$175 per 1000. Minneapolis Floral Co., Minneapolis, Minn.
S. A. F. CONVENTION ACCOMMODATIONS
Tower Hotel, Niagara Falls, N. Y.
For page see List of Advertisers.
SAGE PLANTS
Good thrifty sage plants from 2-inch pots, \$1.50 per 100; ready now. Cash with order. Virginia Nursery Co., Purcellville Va.
SALVIAS
Salvia splendens, extra strong, 2-in. plants, \$2.00 per 100; \$20.00 per 1000. This is elegant stock, large and strong enough for 4-in. pots. N. E. Beck, Massillon, O.

SEEDS

T. J. Grey Co., 32 So. Market St., Boston, Mass.
For page see List of Advertisers.
Joseph Breck & Sons, 61 and 62 N. Market St., Boston, Mass.
For page see List of Advertisers.
W. Atlee Burpee & Co., Philadelphia.
For page see List of Advertisers.
J. M. Thorburn & Co., 33 Barclay St., N. Y.
For page see List of Advertisers.
A. T. Boddington, 342 W. 14th St., N. Y.
For page see List of Advertisers.
H. F. Mitchell Co., 1017 Market St., Phila.
For page see List of Advertisers.
James Vick's Sons, Rochester, N. Y.
Vick's Superb Panay Seed.
For page see List of Advertisers.
Hjalmar Hartmann & Co., 12 Stormgade, Copenhagen, Denmark.
Cauliflower and Cabbage Seed.
For page see List of Advertisers.
Rickards Bros., 37 E. 19th St., New York.
For page see List of Advertisers.
R. & J. Farquhar & Co., 67 So. Market St., Boston.
For page see List of Advertisers.
C. C. Morse & Co., 48-56 Jackson St., San Francisco, Cal.
For page see List of Advertisers.
H. E. Fiske Seed Co., Faneuil Hall Sq., Boston.
Primula Fringed Smeusis.
For page see List of Advertisers.
Brazilian Seed Growers Co., San Jose, Cal.
For page see List of Advertisers.
O. V. Zangen, Hoboken, N. J.
For page see List of Advertisers.
Stump & Walter Co., 50 Barclay St., New York.
For page see List of Advertisers.
Bloomsdale Seed Farms, Bristol, Pa.
Onion Seed.
For page see List of Advertisers.
W. F. Allen, Salisbury, Md.
For page see List of Advertisers.
Weeber & Don, 114 Chambers St., New York.

Asparagus Pl. Nanus, \$2.50 per 1000. Plant early. Asparagus Plants 14 to 18 inches high, \$6 per 100. Peter Mack, Box 172, Orlando, Fla.

Davis Perfect and Burrell's Klondike Cucumber Seed, 50c. per pound. Finest slicing varieties grown. D. V. Burrell, Rocky Ford, Colorado.

SMILAX

Smilax, choice young plants from fall; \$3.00 per 1000, 2000 for \$5.00, 5000 for \$10.00; 50c. per 100 by mail. F. A. Baller, Bloomington, Ill.

SPHAGNUM MOSS

Live Sphagnum moss, orchid peat and orchid baskets always on hand. Lager & Hurrell, Summit, N. J.

SPRAYERS

Charles J. Jager Co., 281-85 Franklin St., Boston.

In writing to Advertisers kindly mention Horticulture

STRAWBERRY PLANTS

C. S. Pratt, Reading, Mass.
The De-ky.

Strawberry plants and Asparagus roots (50 varieties). Catalog free. C. Peirce, Dighton, Mass.

STEAM TRAP

E. Hippard, Youngstown, O.

TRITOMAS

Henry A. Dreer, 714 Chestnut St., Phila.
For page see List of Advertisers.

TO-BAK-INE

E. H. Hunt, Genl. Agt., 76-78 Wabash Av., Chicago.
For page see List of Advertisers.

VENTILATING APPARATUS

Pierson U-Bar Co., 1 Madison Sq., N. Y.
For page see List of Advertisers.

Foley Mfg. Co., Western Ave., between 25th & 26th Sts., Chicago.
For page see List of Advertisers.

John A. Payne, 230-274 Culver Ave., Jersey City, N. J.
For page see List of Advertisers.

The Advance Co., Richmond, Ind.
For page see List of Advertisers.

Quaker City Machine Co., Richmond, Ind.
20th Century Ventilating Arm.
For page see List of Advertisers.

VENTILATING MACHINERY. New Model encased, self-oiling gear; Standard Model Open Gear. Lord & Burham, 1133 Broadway, N. Y.

VERBENAS

Mammoth verbenas, strong, 2 in. plants from seed, in red, white, pink, purple and striped shades, separate or mixed, \$2.00 per 100; \$20.00 per 1000. N. E. Beck, Massillon, O.

VIOLETS

William Sim, Cliffondale, Mass.
Violet Boston.

For page see List of Advertisers.

Violet cuttings, "Marla Louisa" Rhinebeck stock, rooted runners, May delivery \$20.00 M. Wm. F. Kasting Co., 383 Elliott St., Buffalo, N. Y.

WEEKLY BOARD FILE

A. F. Lewis Mfg. Co., E. Boston, Mass.
For page see List of Advertisers.

WIREWORLD

Reed & Keller, 122 W. 25th St., N. Y.
For page see List of Advertisers.

Wirework. Write for our catalogue. Holton & Hunkel Co., Milwaukee, Wis.

William E. Hellscher's Wire Works, 38-40 Broadway, Detroit, Mich.

Headquarters for wire work. Send for list. Ball & Betz, 31 E. 3rd St., Cincinnati, O.

The "Just Right" kind. Send for price list. Frank W. Ball, 31 East Third Street, Cincinnati, O.

WHOLESALE FLORISTS**Boston**

N. F. McCarthy & Co., 84 Hawley St., Boston.

For page see List of Advertisers.

H. M. Robinson & Co., 15 Province St. and 9 Chapman Pl., Boston.

For page see List of Advertisers.

Welch Bros., 226 Devonshire St., Boston.
For page see List of Advertisers.

Buffalo

Wm. F. Kasting Co., 383-87 Elliott St., Buffalo, N. Y.

For page see List of Advertisers.

Chicago

Chas. W. McKellar, 51 Wabash Ave., Chicago.

For page see List of Advertisers.

Peter Reinberg, 51 Wabash Ave., Chicago.
For page see List of Advertisers.

E. F. Winterson Co., 45-49 Wabash Ave., Chicago.

For page see List of Advertisers.

J. A. Rudlong, 37-39 Randolph St., Chicago.
For page see List of Advertisers.

Detroit

Michigan Cut Flower Exchange, 38 and 40 Broadway, Detroit, Mich.

For page see List of Advertisers.

WHOLESALE FLORISTS—**Continued****Minneapolis**

Rice Bros., 115 N. 6th St., Minneapolis, Minn.

For page see List of Advertisers.

New York

J. K. Allen, 106 W. 28th St., New York.
For page see List of Advertisers.

J. S. Fenrich, 110 W. 28th St., New York.
For page see List of Advertisers.

Ford Bros., 48 W. 28th St., New York.
For page see List of Advertisers.

H. E. Froment, 57 W. 28th St., New York.
For page see List of Advertisers.

Alex. J. Guttman, 43 W. 28th St., New York.
For page see List of Advertisers.

E. C. Horan, 55 W. 28th St., New York.
For page see List of Advertisers.

A. H. Langjahr, 55 W. 28th St., New York.
For page see List of Advertisers.

James McManus, 42 W. 28th St., New York.
For page see List of Advertisers.

John I. Raynor, 49 W. 28th St., New York.
For page see List of Advertisers.

W. F. Sheridan, 39 W. 28th St., New York.
For page see List of Advertisers.

Traendly & Schenck, 44 W. 28th St., New York.
For page see List of Advertisers.

John Young, 51 W. 28th St., New York.
For page see List of Advertisers.

Moore, Hentz & Nash, 55 and 57 W. 26th St., New York.
For page see List of Advertisers.

Frank S. Hicks & Co., 39 W. 28th St., New York.
For page see List of Advertisers.

Wm. H. Kuebler, 28 Willoughby St., Brooklyn, N. Y.
For page see List of Advertisers.

Phillip F. Kessler, 55 and 57 W. 26th St., New York.
For page see List of Advertisers.

A. Moltz, 55-57 W. 26th St., New York.
For page see List of Advertisers.

B. S. Sittin, Jr., 55 W. 26th St., New York.
For page see List of Advertisers.

Millang Bros., 41 W. 23th St., New York.
For page see List of Advertisers.

Frank Millang, 57 W. 26th St., New York.

Philadelphia

W. E. McKissick, 1619-1621 Ranstead St., Philadelphia, Pa.

For page see List of Advertisers.

Leo Niessen Co., 1209 Arch St., Philadelphia, Pa.

For page see List of Advertisers.

The S. S. Pennock-Meehan Co., 1608-18 Ludlow St., Philadelphia, Pa.

For page see List of Advertisers.

Edward Reid, 1526 Ranstead St., Philadelphia, Pa.

For page see List of Advertisers.

Pittsburg

J. B. Murdoch & Co., 714 Penn Ave., Pittsburg, Pa.

For page see List of Advertisers.

San Francisco

Alex. Mann, Jr., Co., 1125 Polk St., San Francisco, Cal.

For page see List of Advertisers.

St. Louis

H. G. Berning, 1402 Pine St., St. Louis, Mo.
For page see List of Advertisers.

WHOLESALE PLANTSMAN

Samuel A. Woodrow, 53 W. 30th St., New York.

For page see List of Advertisers.

WILD SMILAX

E. A. Beaven, Evergreen, Ala.
Southern Wild Smilax: Log Mosae.
For page see List of Advertisers.

New Offers in This Issue.**BEDDING PLANTS, BAY TREES AT AUCTION.**

Wm. Elliott & Sons, 42 Vesey St., New York.

For page see List of Advertisers.

BERBERIS THUNBERGII.

Oak Hill Nurseries, Roslindale, Mass.
For page see List of Advertisers.

CALLA BULBS.

A. Mitting, 17-23 Kennan St., Santa Cruz, California.

For page see List of Advertisers.

CAPE JASMINE BUDS.

Chas. Ehlers, Houston, Texas.
For page see List of Advertisers.

CHRYSANTHEMUMS: GERANIUMS.

H. L. Cameron, No. Cambridge, Mass.
For page see List of Advertisers.

FORGET-ME-NOTS.

Warren Shinn, Woodstown, N. J.
For page see List of Advertisers.

HARDY HYBRID AND DWARF RHODODENDRONS.

Eastern Nurseries, Jamaica Plain, Mass.
For page see List of Advertisers.

HIGH GRADE DUTCH BULBS.

W. J. Eldering & Son, Overveen, Haarlem, Holland.

For page see List of Advertisers.

LILIES, HYDRANGEA, SPIRAEA, FOR DECORATION DAY.

W. W. Edgar Co., Waverley, Mass.
For page see List of Advertisers.

LILIUM FORMOSUM.

H. F. Mitchell Co., Philadelphia.
For page see List of Advertisers.

ORCHIDS.

Komitsch & Junge, Secaucus, N. J.
For page see List of Advertisers.

SALVIA SPLENDENS: CARNATIONS.

Cobanzie Carnation Co., New London, Ct.
For page see List of Advertisers.

SHEEP MANURE.

Henry A. Dreer, 714 Chestnut St., Philadelphia.

For page see List of Advertisers.

VEGETABLE PLANTS.

R. Vincent, Jr. & Sons Co., White Marsh, Maryland.

For page see List of Advertisers.

USEFUL BOOKS.

We can supply the following books, postpaid, at the prices listed:—

The Chrysanthemum. Herrington. Price, 50 cts.

How to Make Money Growing Violets. Saltford. Price, 25 cts.

Daffodils-Narcissus and How to Grow Them. A. M. Kirby. Price, \$1.10.

Commercial Violet Culture. Dr. B. T. Galloway. Price, \$1.50.

Water Gardening. Peter Bisset. Price, \$2.50.

Lawns and How to Make Them. Leonard Barron. Price, \$1.10.

Roses and How to Grow Them. By Many Experts. Price, \$1.10.

The New Cyclopaedia of American Horticulture. L. H. Bailey. Four volumes; \$20.00.

How to Make School Gardens. H. D. Hemenway. Price, \$1.10.

How to Make a Fruit Garden. S. W. Fletcher. Price, \$2.20.

How to Plan the Home Grounds. S. Parsons, Jr. Price, \$1.10.

List of Advertisers

Advance, The Co. 615	Lager & Hurrell 601
Allen J. K. 606	Landreth D. Seed Co. 599
Allen W. F. 598	Langran, Alfred H. 608
Altimo Culture Co. 599	LaTribune Horticulture 596
American Nursery 596	Leonard I. & J. 586
American Nursery Co. 596	Leuthy A. & Co. 601
Aschmann G. 601	Lewis A. F. Mfg. Co. 603
Atlanta Floral Co. 603	Lord & Burnham Co. 616
Bambrick Thos. H. 613	Littlenfield H. F. 586
Barrows H. H. & Son 601	Manda Jos. A. 601
Bayersdorfer H. & Co. 604	Mann, Alex. Jr. Co. 604
Bay State Nurseries 597	MacMulkio E. A. 603
Beaveo E. A. 604	McCarthy N. F. & Co. 607
Berning H. G. 607	McConnell Alex. 602
Bloomdale Seed Farms 199	McKellar Charles W. 604
Boddington A. T. 599	McKissick, W. E. 604
Boston Florist Letter Co. 603	McManus Jas. 609
Boston Plate and Window Glass Co. 614	Michell H. F. Co. 588-614
Bosch, Felix 601	Michigan Cut Flower Exchange 607
Bostrom-Ercy Mfg. Co. 605	Milling Bros. 607
Bowe, M. A. 602	Mitting, A. 586
Braslan Seed Growers Co. 599	Moltz, A. 607
Breck Joseph & Sons 599	Moninger J. C. 615
Breitmeyer's J. Sons 602	Moore, Hentz & Nash 607
Bremond Marital 600	Morse C. C. & Co. 599
Bridgeman's Seed Warehouse 599	Murdoch J. B. & Co. 604
Budlong J. A. 604	Murray Samuel 602
Burpee W. A. & Co. 599	New England Nurseries 596
Cameron H. L. 586	Niessen Leo Co. 604
Carrillo & Baldwin 601	Oak Hill Nurseries 596
Cassidy I. 615	Ordowner Bros. 601
Champion J. N. & Co. 603	Ouwerkerk P. 595
Chicago Carnation Co. 586	Paletrophe P. R. Co. 604
Clarke's David, Sons 602	Park Floral Co. 602
Clary's Horticultural Co. 607	Payne John A. 615
Cohanzie Caration Co. 586	Peacock-Meehan Co. 604
Conard & Jones Co. 586	Perkins St. Nurseries 601
Cooke G. H. 612	Pierce F. O. Co. 614
Cowee A. 586	Pierson, A. N. 586
Craig, Robt. Co. 600	Pierson F. R. Co. 597
Dana W. J. 613	Pierson U Bar Co. 616
Dungee & Conard Co. 597	Pechlmann Bros. Co. 597
Doane Geo. B. & Son 615	Pulverized Manure Co. 614
Donohoe W. H. 602	Quaker City Machine Co. 615
Dorner F. Sons & Co. 586	Rawson W. W. & Co. 614
Dreer H. A. 587-614-615	Raynor John I. 606
Dunlop John H. 603	Red Oak Nurseries 586
Dysart R. J. 607	Reed & Keller 607
Eagle Metal & Supply Co. 615	Reid Edw. 604
Eastern Nurseries 595	Reinberg Peter 604
Edgar, W. W. Co. 600	Rice Bros. 604
Edwards Folding Box Co. 604	Rickards Bros. 599
Ehlers 601	Robinson H. M. & Co. 607
Eldering W. J. & Son 600	Rock Wm. L. Flo. Co. 602
Elliott Wm. & Sons 595	Roehrs Julius Co. 607-601
Esler J. G. 615	Roland, Thomas 601
Ernest W. H. 614	Rolker August & Sons 600-614
Eyres 602	Rose Hill Nurseries 586
Farquhar R. & J. & Co. 597	Sander & Son 601
Ferlich J. S. 606	Schulz Jacob 602
Fiske, H. E. Seed Co. 590	Scott, John 601
Foley Mfg. Co. 615	Sheridan W. F. 606
Ford Bros. 606	Shinn, Warren 595
Froment H. E. 616	Shurtlett J. B. & Son 586
Galvin Thos. F. 603	Siggers & Siggers 615
Grey T. J. Co. 599	Sim, Wm. 595
Gude Bros. Co. 602	Situations & Wants 613
Guttman Alex. J. 606	Skidelsky S. S. 586
Haerens A. 600	Slinn B. S. Jr. 601
Hall Assn. 615	Smyth Wm. J. 602
Haines, J. E. 586	Standard Plate Glass Co. 614
Hart, Geo. B. 603	Stearns A. T. Co. 615
Hartmann Hjalmar & Co. 599	Storts & Harrison 595
Hauswirth M. C. & J. E. 602	Stump & Walter Co. 586-599-614
Herbert David & Son 600	Thorburn J. M. & Co. 590
Hews A. H. & Co. 614	Totty Chas. H. 586
Hicks Frank S. & Co. 607	Tower Hotel 595
Hilfinger Bros. 614	Traendly & Schenck 597
Hill, The E. G. Co. 597	Valentine, J. A. 602
Hoening M. J. 595	Veltbays K. 601
Hoffman 603	Vick's Jas. Sons 599
Horan E. C. 606	Vincent R. Jr. & Sons 598-600
Houghton & Clark 603	Ward R. M. & Co. 600
Hunt E. H. 614	Waterer John & Sons 596
Jackson Nurseries 597	Weathered Co. 616
Jacobs S. & Sons 615	Weber F. C. 602
Kastlog W. F. 607	Welch Bros. 602
Kessler, P. F. 605	Wilson 602
King Cons. Co. 615	Winterson, E. F. Co. 604
Komitsch & Juage 601	Withold Geo. Co. 603
Koral Mfg. Co. 603	Woodrow, Sam'l A. 607
Kramer Bros Fdy Co. 600	Yokohama Nursery Co. 601
Kuebler Wm H. 607	Young John 606

IS YOUR NAME IN THE ABOVE LIST? IF NOT, WHY NOT?

COURT DECISION IN CUSTOM HOUSE CASE.

United States vs. Ouwerkerk.

U. S. Circuit Court of Appeals, Second Circuit. April 14 1908. No. 128 (sup 4136).

Evergreen Seedlings—Laurels Rhododendrons—Nursery Stock.

Species of the laurel (*Aucuba japonica* and *Kalmia latifolia*) and of the rhododendron (*Rhododendron ponticum*), which retain their verdure throughout the year, are "evergreens" within the meaning of paragraph 252, tariff act of 1897; and under said paragraph seedlings of those plants are dutiable as "evergreen seedlings" rather than as nursery stock.

Appeal from the circuit court of the United States for the southern district of New York.

[Decision adverse to the Government.]

For decision below see 153 Federal Reporter, 916 (T. D. 28183), in which the circuit court affirmed a decision by the Board of United States General Appraisers, G. A. 6169 (T. D. 26772), which had sustained protests by P. Ouwerkerk against the assessment of duty by the collector of customs at the port of New York.

The merchandise in dispute consisted of three varieties of plants, designated as *Aucuba japonica* or Japanese laurel, *Rhododendron ponticum*, and *Kalmia latifolia* or American laurel. The Board held these plants to be dutiable under paragraph 152, tariff act of 1897, as "evergreen seedlings." The Government contended that they had been properly classified under the provision in the same paragraph for "nursery stock."

The theory of the Government's contention is that the term "evergreen" is restricted to such evergreen plants as the conifers and box. The Board of General Appraisers held, however—and its decision was affirmed by the circuit court without opinion—that the term is not so restricted, but applies to seedlings of all plants which retain their greenness throughout the year, and that it is sufficient if a plant fall within the general class of evergreens, irrespective of whether it is hardy in a particular locality or under different climatic conditions. The plants in question, being shown to be "evergreen" in this sense, were held to be "evergreen seedlings," as above set forth.

D. Frank Lloyd, assistant United States attorney, for the United States. Hatch & Chute (Walter F. Welch of counsel) for the importer.

Before Lacombe, Ward and Noyes, Circuit Judges.

Per Curiam: Decision of circuit court affirmed.

John P. Brown, editor of *Arboriculture*, is doing a commendable forestry work in Alabama. For the past four months he has been located at Carney, where he has converted a 250 acre tract of rough woods into a forest of *Catalpa speciosa*.

You will find something worth reading on every page of HORTICULTURE.

WANTS, FOR SALE, ETC.
 Advertisements in this column one cent a word. Initials count as words. Cash with order. All correspondence addressed "care HORTICULTURE" should be sent to 11 Hamilton Place, Boston.

HELP WANTED
FOREMAN WANTED
 A man with good experience in Roses and Carnations to take charge of a commercial establishment growing for the wholesale trade.
W. J. DANA
 Wellesley Hills, Massachusetts

HORTICULTURE needs a wide-awake representative in every town in the land. Good commission paid on advertising and subscriptions. If you are ambitious, write for terms.

WANTED: Manager foreman, to take entire charge of our plant; must be strictly sober, reliable and capable of conducting a large place successfully and be endorsed by former business associates. Also, must be able to take up about \$5,000 worth of stock to have a working interest in the firm. L. P. Darnell, Treasurer, The J. M. Gasser Company, 1035 Prospect Avenue, Cleveland, O.

WANTED: An all-round handy man, experienced in outdoor gardening, familiar with trees and shrubs; horse and cow to look after; good pay and when needed extra help; cottage and vegetables. Must be sober and faithful. Address C. C., care Horticulture, 11 Hamilton Place, Boston.

SITUATIONS WANTED
GOOD MEN
 When you need good men, skilled or unskilled, Write:
THOS. H. BAMBRICK
 34 South 7th Street Philadelphia
 Help of all kinds, including that for Florists, Nurserymen, Seedsmen and the Horticultural trade generally.

SITUATION WANTED by good grower as foreman of first-class place; long experience on good wholesale and retail places with roses, carnations, palms, ferns and general pot and nursery stock for first-class trade. Good worker, sober and ambitious. References. State wages and full particulars. Address Rose Grower, 13 Decatur St., Boston, Mass.

GARDENER: Situation wanted on a private estate, or assistant in greenhouse; thoroughly experienced in all details of outdoor gardening; country estate preferred. Alex. D. Salomon, No. 34 Central St., Lynn, Mass.

WANTED: Situation in a private or commercial place where general line of plants is grown; experienced in all lines; also understand herbaceous plants and shrubs. First-class references. C. G., care of Horticulture.

SITUATION WANTED in general greenhouse work; single, age 35, five years' experience, commercial. Address W. W., care HORTICULTURE.

FOR SALE
 FOR SALE—A large consignment of 16x24 double thick American glass, A and B quality. For further information write Parshelsky Brothers, 59 Montrose Avenue, Brooklyn, N. Y.

GREENHOUSES BUILDING OR CONTEMPLATED.

- Dover, N. H.—C. L. Howe, house 24x125.
- Eugene, Ore.—R. Rae, range of houses.
- Salida, Colo.—J. H. Freeman, range of houses.
- Post Falls, Ind.—Wollan & McKay, range of houses.
- Hollywood, Calif.—El Reah Greenhouses, house 45x200.

LIST OF PATENTS.

- 884,365. Plow. Aurin M. Chase, Syracuse, N. Y., assignor to Syracuse Chilled Plow Company, Syracuse, N. Y., a Corporation of New York.
- 884,416. Sod Trimmer. Robert E. Poindexter, Indianapolis, Ind.
- 884,473. Plant Protector. Eugene C. Dawson, Jackson, Tenn.
- 884,496. Power Driven Plow. Andrew W. Harpstrite, Mowequa, Ill.
- 884,515. Manure-Spreader. Bertie E. Miller, Brandon, Iowa.
- 884,651. Lawn Mower. James H. Frey, Vincennes, Ind., assignor of one-half to Frank C. Hardware, Vincennes, Ind.
- 884,652. Plow. Thomas H. Fuller, Lafayette, Ala.
- 884,676. Cultivator Attachment. Marshall L. McClure, Republic, Mo.
- 884,790. Planter. John C. Atterbury, and Charles La Plant, Madison, Mo., said La Plant assignor of one-fourth to Joseph W. Baker, Monroe County, Mo.
- 884,814. Combined Weeder and Cultivator. Edsill R. Gordan and Delwin L. W. Wolfe, Harrington, Wash.
- 884,839. Fruit Pickers Platform. Charles A. McDermott, Sultana, Cal.
- 885,091. Setting Plants. John L. Sinclair, San Antonio, Tex.
- 885,126. Fertilizer Distributer. Ebin N. Yarbrough, Oktona, Ark.
- 885,309. Rake. Gideon S. Adams, Seaville, N. J.
- 885,471. Hoeing Machine. Otto Harder, Hokendorf, Germany.
- 885,535. Harrow and Cultivating Implement. Samuel T. Sherrill, Mexia, Tex.

NEWS NOTES.

R. Smith has purchased the greenhouses of Shirley Woner, Sandusky, O.

The Chicago office and salesrooms of A. H. Hews & Co., flower pot manufacturers, Cambridge, Mass., is located at 456 North Branch St., with M. F. Mooney in charge.

The interest which the McClures held in Suburban Life has been bought back by the Suburban Press and the publication office will be moved to Harrisburg, Pa., next week, thus concentrating editorial, circulation and manufacturing departments under one roof. An advertising office under the management of Frank A. Arnold will be maintained in New York city. Mr. Farrington, who has always been the managing editor, will be editor in toto.

STANDARD PLATE GLASS CO.

Manufacturers—Importers—Jobbers

NOW IS THE TIME TO BUY

FRENCH OR AMERICAN GREENHOUSE GLASS

LOWEST PRICES ON REQUEST

26-30 Sudbury St. BOSTON, MASS. 61-63 Portland St.

DON'T EXPERIMENT

USE

To-BAK-INE

and your stock will be free from insects, clean, and the blooms will not be discolored.

Send for full information of

W. W. RAWSON & CO.,
5 Union St., Boston.

STUMPP & WALTER CO.,
50 Barclay St., New York.

HENRY F. MICHELL & CO.,
1018 Market St., Philadelphia.

E. H. HUNT, Gen'l Agent,
76-78 Wabash Ave., Chicago.



The Best Bug Killer and Bloom Saver

For PROOF Write to

P. R. Palethorpe Co.
OWENSBORO, KY.

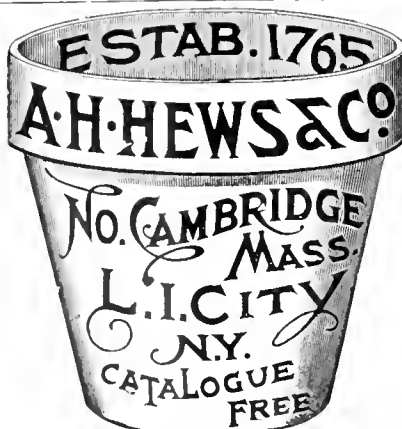

BOSTON PLATE & WINDOW GLASS CO.

GREENHOUSE GLASS

German and American

261 to 287 A St., Boston 20-22 Canal St.

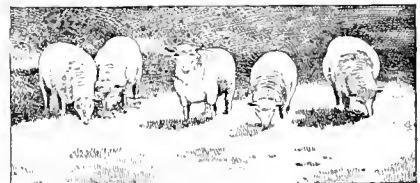

DREER'S SHEEP MANURE
(WIZARD BRAND)
FLORIST 100 lbs., \$1.75; 500 lbs., \$8.00;
SPECIALTIES 1,000 lbs., \$15.00 Ton, 2,000 lbs., \$30.00
HENRY A. DREER, 714 Chestnut St., Phila., Pa.



Cattle Manure In Bags Shredded or Pulverized

Best and safest manure for florists and greenhouse use, absolutely pure, no waste, no danger. Write for circulars and prices.

The Pulverized Manure Co.,
31 Union Stock Yards, Chicago

STANDARD FLOWER POTS

Packed in small crates, easy to handle.

Price per crate		Price per crate	
1500 2 1/2 in. pots	In crate \$4.88	120 7 1/2 in. pots	In crate \$4.20
1500 2 1/4 " "	" " 5.25	60 8 " "	" " 3.00
1500 2 1/2 " "	" " 6.00	HAND MADE	
1000 3 " "	" " 5.00	48 9 in. pots	In crate \$3.60
800 3 1/2 " "	" " 5.80	24 11 " "	" " 4.80
500 4 " "	" " 4.50	24 12 " "	" " 3.60
320 5 " "	" " 4.51	12 14 " "	" " 4.80
144 6 " "	" " 3.16	6 16 " "	" " 4.50

Seed pans, same price as pots. Send for price list of Cylinders for Cut flowers, Hanging Baskets, Lawn Vases, etc. Ten per cent. off for cash with order. Address Hillfinger Bros., Pottery, Fort Edward, N. Y. August Rolker & Sons, Agts., 31 Barclay St., N. Y. City.

Standard Flower.. POTS

If your greenhouses are within 500 miles of the Capital, write us, we can save you money

W. H. ERNEST

28th and M Street WASHINGTON D. C.

In ordering goods please add, "I saw it in HORTICULTURE."

John A. Payne

Greenhouse Designer and Builder
260-274 Culver Ave., Jersey City, N. J.
Purlin



The PAYNE "Grip-tight Fitting"

for purlins and columns, is the strongest and most secure fitting yet produced for this purpose, because it is held fast by two bolts where the greatest grip is required. They cannot break because the bolts are close to edge of pipe.

Iron and Wood Frame Greenhouses of every type. Material only or erected.

Let us estimate on your requirements.

Column

Everything for the Greenhouse

IRON PIPE

SECOND HAND

WROUGHT IRON PIPE, for Steam, Water, Gas or Oil, Fences or Posts. All Sizes. Price Low.

GEO. B. DOANE & SON
18 Midway Street, BOSTON
Telephone, Main 4419

There are some GOOD BARGAINS listed in the

BUYERS' DIRECTORY, Pages 608 to 612 this week.

I. CASSIDY

Designer and Builder of

Iron and Wood Greenhouses

Factory: Summer Ave and Erie R. R. Newark, N. J.

R. TONAWANDA, N. Y.



GREENHOUSE CONSTRUCTION LUMBER

John C. Moninger Co.
117 E. Blackhawk St., CHICAGO

THE FOLEY MFG. CO.

CHICAGO

Completely equipped with up-to-date machinery for the making of material for

GREENHOUSE CONSTRUCTION

From a Full Supply of Thoroughly Seasoned Lumber

Send your sketches to our draughtsmen for completion and suggestion. Permit us to figure your proposed work, large or small.

We guarantee our prices will save you money
FOLEY VENTILATING APPARATUS IS THE BEST

Simple in Erecting. Is Easiest of Operation. It Will Last a Lifetime. Its Price is the Lowest. Will Ventilate Any Size House. Prices and Circulars on Application.

Our 1908 Catalogue Greenhouse Material Sent Postpaid on Request.

THE FOLEY MFG. CO., WESTERN AVENUE
25th and 26th STS., CHICAGO

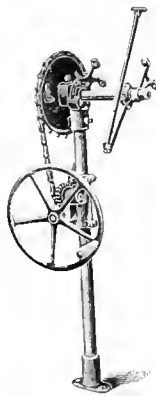

The Advance Ventilating Apparatus

Our line has been "pushing" its way into the good graces of florists in 38 states in 4 years' time. Its "pull" has been its intrinsic merits, making it possible to sell 68 machines, 37-36-24-16-13, respectively, to single florists, together with scores of sales of 5 to 10 machines to others. Get our estimate, and give us a trial. You will be pleased.

The Advance Co.
RICHMOND, IND.

CYPRESS SASH BARS

82 feet or longer
HOT BED SASH
PECKY CYPRESS BENCH LUMBER

GREENHOUSES

ERECTED AND EQUIPPED COMPLETE IF DESIRED

Write for Circular "D" and Prices

The A. T. STEARNS LUMBER CO.
NEPONSET, BOSTON, MASS.

In writing advertisers kindly mention HORTICULTURE.

S. JACOBS & SONS

Manufacturers of GULF CYPRESS

GREENHOUSE MATERIAL

HOT-BED-SASH & FRAMES

Jobbers in Boilers-Pipe-Fittings and

GLASS on which we can quote attractive prices. Disc on large quantities. We furnish everything for Greenhouse Building
1365-1379 Flushing Avenue
BROOKLYN, - NEW YORK

Evans 20th Century Arm

Will not twist your shafting pipe. Give it a trial and you will use no other. Three times the power of elbow arms.

Write for Catalogue
QUAKER CITY MACHINE CO.
Richmond, Ind.

SECOND HAND PIPE & BOILER TUBES

Of all sizes, in good condition, suitable for steam purpose, coupled and threaded, for sale at low rates.

5000 feet 1 inch pipe, 3c. per ft.; 5000 feet 1 1/4 inch pipe, 4c. per ft.; 3000 feet 1 1/2 inch pipe, 5c. per ft.; 2000 feet 2 inch pipe, 6 1/2 c. per ft.

EAGLE METAL & SUPPLY CO.,
Johnson and Union Aves., BROOKLYN, N. Y.

PATENTS

Trademarks and Copyrights

Send your business direct to Washington. Saves time and insures better service. Personal attention guaranteed. Twenty-five years' active service. SPECIALTY: "Working on the Failure of Others."

SIGGERS & SIGGERS

PATENT LAWYERS

Box 9, National Union Building
Washington, D. C.

In ordering goods please add "I saw it in HORTICULTURE."

Holds Glass Firmly
See the Point AT
PEERLESS

FULL SIZE
No. 2

Glassing Points are the best. No rights or lefts. Box of 1,000 points 75 cts. postpaid.

HENRY A. DEER,
714 Chestnut St., Phila., Pa.

The FLORISTS' HAIL ASSOCIATION OF AMERICA, insurer of 28,000,000 sq. ft. of glass. For particulars address John C. Esler, Sec'y, Saddle River, N. J.

THE HOUSE OF GREATEST SUNLIGHT

LIGHTEST INTERIOR in the WORLD
 THIS HOUSE 33 1/2 FEET WIDE
 Note: No Columns

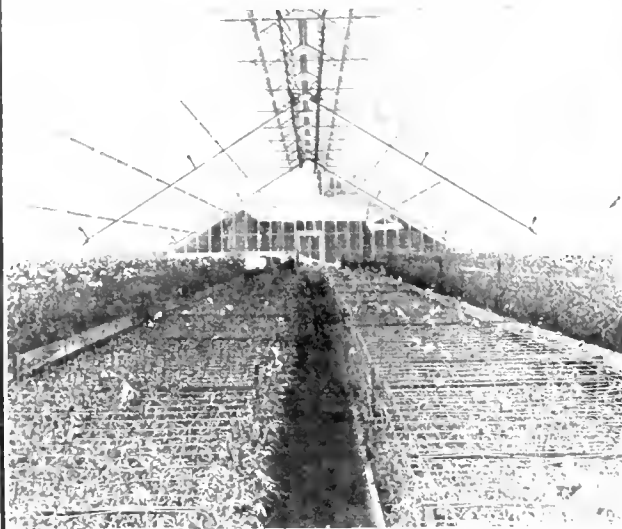

Erected for J. J. BROZAT, Bloomfield, N. J.

BY THE

WEATHERED COMPANY

IRON FRAME, SEMI-IRON FRAME, OR ALL SASH
 BAR HOUSES, ERICID, OR MATERIAL ONLY

SEE THE CATALOGUE

P. O. Address Box 789 NEW YORK CITY, N. Y.



THE HOUSE OF "Greatest Efficiency"

That is what our Sectional Iron Frame Construction stands for. You get increased efficiency on one hand, decreased running cost on the other. Nowadays, you can't ignore either. Send for circular.

WE MAKE EVERY PART OF A GREENHOUSE
 PUT THE GLASS. WE SELL ANY PART.

LORD & BURNHAM CO.

MAIN SALES OFFICE:

1133 BROADWAY, NEW YORK

BOSTON: 919 Tremont Building
 PHILADELPHIA: 1215 Filbert St.

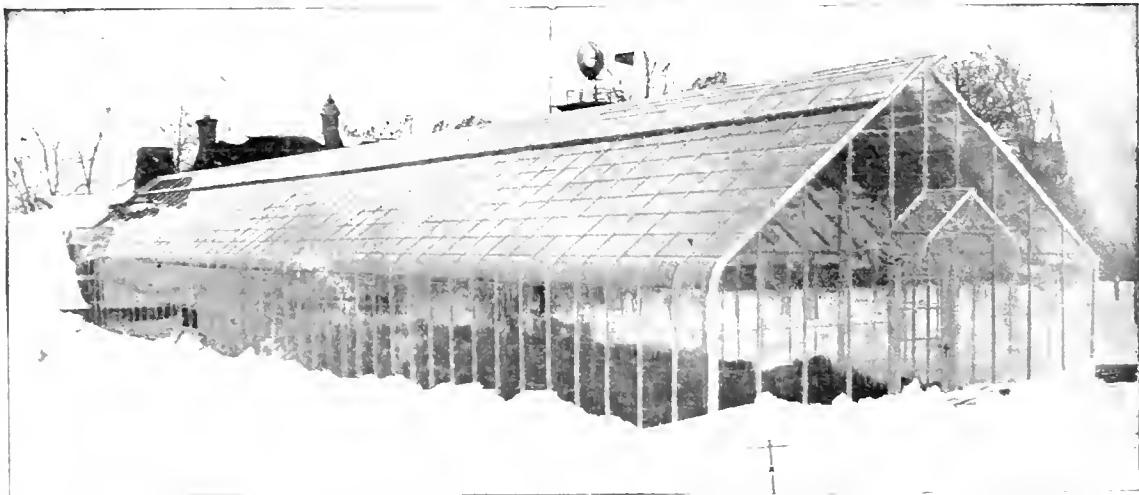

THEY HAVE SNOW FREE ROOFS

Snow won't stay on — no gutter or eave plate to back it up. The U-Bar is the only successful curved eave house. It is the lightest, strongest, simplest, most enduring, attractive and productive house, and costs less to maintain. Send for Catalog.

The ideal construction for private estates, parks, public institutions and florists' storerooms

U-BAR GREENHOUSES

PIERSON

DESIGNERS AND BUILDERS



U-BAR CO.

1 MADISON AVE., NEW YORK

HORTICULTURE

Vol. VII.

MAY 9, 1908

No. 19

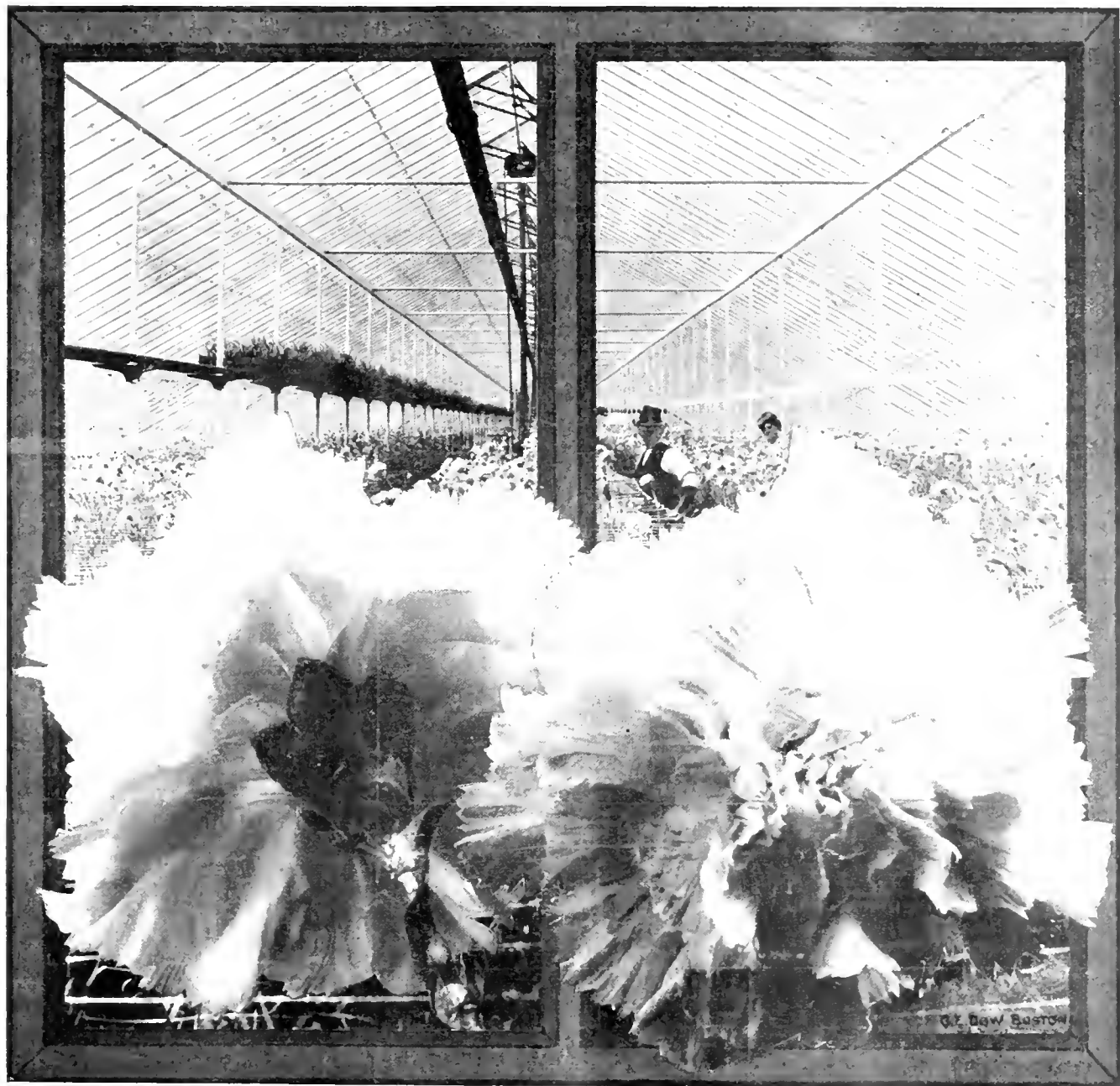

CARNATION BAY STATE

View in House and Front and Back Portrait of Flower (full size).



DEVOTED TO THE
Florist, Plantsman, Landscape Gardener and Kindred Interests

PUBLISHED EVERY SATURDAY AT 11 HAMILTON PLACE, BOSTON, MASS.

SUBSCRIPTION, \$1.00



W. A. C. 1908



A GARDENIA BLOOM. One-half actual size.

Gardenias

(Grandiflora Cape Jessamine Buds)

White, wax-like petals; dark, lustrous green leaf; fragrance retained for two weeks in perfect condition.

Our firm will fill orders for over a million buds this month. What advertising we have already done will sell all the stock we can furnish for Decoration Day. This is already indicated by orders received — but we can fill orders promptly between the dates of May 10 and 20 inclusive, which will make arrivals in the East May 14 to 25. We want new customers to try small lots of one to five hundred within these dates, so that they can be assured of receiving salable stock for the entire season in future, from our increased plantings.

Quotations net, F. O. B. here for standard stem first

quality of buds and extra good foliage, per 1000 \$7.50
(500 at thousand rate)

On orders of 3000 or more, per 1000 6.50

Less than 500, per 10085

We guarantee good condition and full fragrance upon arrival. The express charge on lots of 200 or more using New York City as a radial point, is about 35c per 100 buds.

C. W. BENSON & CO., Alvin, Tex.

TUBEROSES

EXCELSIOR DWARF PEARL 3 x 4 \$.60 per 100, \$5.00 per 1000
4 x 6— 1.00 per 100, 8.00 per 1000

STUMPP & WALTER CO., 50 Barclay Street, NEW YORK

A HALF MILLION CALLA BULBS FOR SALE

CALLA ETHIOPICA BULBS, 7 to 8 inch circumference, \$65.00 per 1000

" " " 5 to 7 " " " 40.00 "

" " " 3 to 5 " " " 25.00 "

250 at 1000 Rates, Freight Prepaid when Cash is sent with Order. Orders booked now for July shipments.

A. MITTING, 17 to 23 Kennan St., Santa Cruz, Cal.

Large Cape Jasmine Buds (GARDENIA GRANDIFLORA)

FOR THE TRADE:

100 Buds packed in basket, \$1.00 400 Buds packed in box, \$3.50

For larger shipments write for prices. Express Rates on Cape Jasmine Buds very low. Can furnish this year 150,000. Season from May 10th to June 5th.

EHLERS, FLORIST, - HOUSTON, TEXAS

CANNAS

Send for our List and Prices

The CONARD & JONES CO. WEST GROVE, PA.

Will send away for worthless dry bulbs when you can gain time and save money by buying at home **Cannas all started for \$2.00 per 100.** Austria, Robusta, Pennsylvania, Italia, Chas. Henderson, Mlle. Berat and Pres. Carnot.

J. B. SHURTLEFF & SON, Cushman Ave., Revere, Mass.

Gloire de Lorraine Begonia

2 1/4 inch pots, \$15.00 per 100
\$140.00 per 1000

Thomas Roland Nahant - - Mass.

HYACINTHS, TULIPS, NARCISSI

AND OTHER BULBS

ROMAN HYACINTHS and the true PAPER WHITE GRANDIFLORA

Ask for our Wholesale Trade List at Hillegom

K. VELTHUYS, Hillegom, Holland
Rep. by FELIX BOSGH, 260 Clarendon St., Boston.

Bedding Plants

All Kinds, Stocky, Good Size, Low Price. Can supply the Trade in quantity.

Just Received

A big shipment of ARAUCARIAS, PALMS, etc. Orders taken now for import for fall delivery.

A LEUTHY, & CO.

PERKINS ST. NURSERIES ROSLINDALE, MASS.

Ipomoea Noctiflora

Best pure white moonvine in market, very fragrant and as big as a saucer. On this variety we have a world-wide reputation as growers and shippers for the last twenty years. Price, 2 1-2 in. pots, \$5.00 per 100. 10,000 are now ready.

GODFREY ASCHMANN, 1012 W. Ontario St., Philadelphia, Pa.

Established 40 Years

Rose Hill Nurseries

New and Rare Plants

NEW ROCHELLE, N. Y.

New York Office, Siebrecht Building, 425 Fifth Avenue

JAPANESE

THE YOKOHAMA NURSERY CO.
31 BARCLAY STR. NEW YORK.

LILIES
PLANTS
BAMBOO STAKES

Dreer's Hardy Climbers

POT GROWN STOCK FOR LATE SHIPMENT

Clematis Hybrids , such as Jackmani, Jackmani Superba, Henryi, Duchess of Edinburgh, Fairy Queen, Sieboldi, Gipsy Queen, Lilacina, Floribunda, Mme. Baron Villard, Mme. Van Houtte, Miss Bateman, Standishi, The Gem, The President and Ville de Lyon, all in strong two-year-old plants	Per Doz.	Per 100
	\$3.00	\$20.00
Clematis Montana Grandiflora , new early flowering variety, very desirable	30c each	3.00
Clematis Montana Rubens , new, identical with above, except that in color it is of a soft rosy red, distinct, novel and a great acquisition	75c each	8.00
Akebia Quinata , strong two-year-old plants	1.25	8.00
Ampelopsis Veitchii , strong two-year-old	1.50	10.00
Ampelopsis Virginica , strong two-year-old	1.25	8.00
Aristolochia Siphon , extra heavy	4.00	30.00
Bignonia Grandiflora , strong roots	3.00	20.00
Honeysuckles Halleana, Evergreen and Variegated , strong, 4-inch pot-grown plants	1.00	7.00
Honeysuckle Heckrothi , strong two-year old	1.75	12.00
Ipomea pandurata , dormant roots	.50	4.00
Lathyrus Latifolius Albus	1.00	7.00
" Splendens	1.00	7.00
Kudzu Vine , strong one-year-old	1.00	7.00
Schizophragma Hydrangeoides , Climbing Hydrangea, strong pot-grown plants	75c each	7.50
Wistaria Sinensis , heavy two-year-old	3.50	25.00
" Alba , heavy two-year-old	4.00	30.00



Henry A. Dreer, 714 Chestnut Street Philadelphia, Pa.

CHRYSANTHEMUMS

FOR IMMEDIATE ACCEPTANCE

I offer 100 Single Chrysanthemums for \$8.00, in 10 or more varieties.

100 large flowered kinds in 10 varieties for \$5.00. This will include some of the newer sorts and is a special cash offer open only to readers mentioning Horticulture.

CHARLES H. TOTTY,
MADISON, N. J.

ROOTED CHRYSANTHEMUM CUTTINGS

Glory of the Pacific, Polly Rose, Ada Byron, Kalb, Halliday, Harry Sinclair, Bonnalton, \$1.50 per 100.
Fair Maid Carnation Cuttings, \$1.00 per 100; \$8.00 per 1000.

H. F. Littlefield, 552 Main St., WORCESTER, MASS.

MONEY MAKERS

CHRYSANTHEMUMS—White and Yellow Bonaffon, Ivory, Rooted Cuttings, \$10.00 per 1000.
Nutt, Poitevine, Ricard and other BEST Geraniums, 4-in. stock, \$7.00 per 100.

H. L. CAMERON
North Cambridge, Mass.

New Violet BOSTON

In introducing this new variety to the trade I wish to state that I have been growing it in quantity for the past two years and do not hesitate to state that it is entirely distinct, a strong grower, a free bloomer, and the best single violet in cultivation. Ready for distribution in April and May. Orders booked now. \$2 per 12; \$12 per 100; \$100 per 1000. 500 at 1000 rate.

WILLIAM SIM, CLIFTONDALE, MASS.

BAY STATE

The big sensation of all the recent Carnation Shows. A noble flower, white with carmine markings.

Now Booking Orders for Next January Delivery.

Rooted Cuttings, \$12.00 per 100, \$100.00 per 1000

ALBERT ROPER, Tewkesbury, Mass.

CARNATIONS

WINONA—The True Pink
\$12.00 per 100, \$100.00 per 1000

	Per 100	Per 1000
Red Chief	\$5.00	\$40.00
Aristocrat	6.00	50.00
Winsor	6.00	50.00
Beacon	6.00	50.00
White Perfection	3.00	25.00
Rose Pink Enchantress	3.00	25.00
Enchantress	3.00	25.00
Lady Bountiful	3.00	25.00

F. DORNER & SONS CO., LAFAYETTE, IND.

ROOTED

CARNATION CUTTINGS

Only the Best Varieties

CHICAGO CARNATION CO., JOLIET ILL.

SOMETHING GOOD

FOR SMALL PRICE

3000 2 1/2 in. Salvia Splendens	\$2.00	per 100
1000 Enchantress Carnations	2.00	"
1000 Prosperity	2.00	"
500 Winsor	6.00	"

Very strong transplanted Asters, sure to please, at 60c per 100.

COHANZIE CARNATION GREENHOUSES, New London, Conn.

JOHN E. HAINES

Bethlehem, Pa.

is the place to order rooted-cuttings of the following varieties for 1908.

John E. Haines, red imperial variegated Pink imperial, Pink Enchantress, Light Pink	Per 100	Per 1000
	\$6.00	\$50.00

Place your orders early for Jan. delivery.

COLEUS

Verschaffeltii, Golden Queen, Fire Brand, Lord Palmerston, Queen Victoria, Beckwith's Gem. Prices of Rooted Cuttings by express, 60c, per 100; \$5 per 1000. Less than 250 of a variety will be charged at the 100 rate.

Golden Bedder, Hero, Tessey, Pearl of Orange, 75c. per 100; \$6 per 1000. Less than 250 of a variety will be charged at the 100 rate.

Fancy Varieties. A very fine assortment of twelve kinds not listed above. 75c. per 100; \$6 per 1000. 250, in assortment, our selection, at the 1000 rate.

MISCELLANEOUS PLANTS

AGERATUM, Stella Gurney, Princess Pauline. SALVIA Splendens, Bonfire, HELIOTROPE. Rooted cuttings, 75c. per 100; \$6 per 1000.

CARNATIONS

Rooted Cuttings	100	1000
Winsor	\$6.00	\$50.00
White Perfection	2.50	20.00
Rose Pink Enchantress	3.50	30.00
Enchantress	2.50	20.00
Queen Louise	2.50	20.00

From 2 1/2 inch pots, add \$1.00 per 100.

ASPARAGUS PLUMOSUS NANUS SEEDLINGS
From flats, \$10.00 per 1000.

CHRYSANTHEMUMS

Standard varieties, ready for shipment. Rooted cuttings, \$2 per 100; \$15 per 1000. Send for list.

A. N. PIERSON, CROMWELL, CONN.

Prices quoted in these columns are for dealers only.

Carnation Cuttings

Both standard varieties and novelties. Stock guaranteed to be first-class. Address,

S. S. SKIDELSKY

1741 North 18th Street. Philadelphia

ORCHIDS

Just Arrived in Fine Condition

ORCHIDS

ORCHIDS



ONE of the largest consignments of plants ever received in the United States at one time; namely, 100 cases Cattleya Trianae, 80 of Cattleya labiata, 40 of C. gigas Sanderiana. Fine importation of Cattleya Schroederiae, C. Harrisoniae, C. citrina, Laelia anceps, Oncidium varicosum Rogersii, O. tigrinum, O. ornithorhynchum, Odontoglossum Insleyii, Odonto. Rossii majus, Dendrobium formosum giganteum, D. Wardianum. To arrive shortly, D. Phalaenopsis, Cattleya Mossiae, C. Percivaliana, C. Gaskelliana, C. Mendelli, C. Warneri. Intending buyers of Orchids would do well to come and see this stock before buying elsewhere. Our prices are reasonably consistent with good stock. All our goods are collected by our own collectors, thereby assuring our customers the best stock the forests afford. Come and see them. These goods if potted at once will yield abundance of flowers the first year, paying for the cost of the plants in the fall.

We also carry a large stock of established Orchids. Also orchid peat, Sphagnum Moss, Baskets, etc. A trial will prove we carry the best stock that can be secured. Come and see for yourself and be convinced of these facts.

Carrillo & Baldwin SECAUCUS, N. J.

HOW TO REACH OUR PLACE—Take Erie R. R. to Homestead, N. J., 3 minutes by trolley to Secaucus; or by trolley from D. L. W. depot, Hoboken, 25 minutes get off post office Secaucus. From Penn. depot, Jersey City, take train on Susquehanna R. R. to Homestead.

CATTLEYA TRIANAE

Just to hand in perfect condition, a large shipment which we offer in cases containing about 40 fine plants aggregating over 450 bulbs, for \$55 per case. Also CATTLEYA LABIATA in cases of 400 bulbs, for \$55 per case. Also ONCIDIUM VARICOSUM ROGERSII, at \$18 per dozen. CATTLEYA MOSSIAE in fine condition in cases of 40 plants, \$55 per case.

LAGER & HURRELL, - - Summit, N. J.

NEPHROLEPIS SCOTTII

in the following sizes, extra good value

25c., 50c., 75c., and \$1

Grand Specimen Plants at \$3, \$4, \$5, \$6.

JOHN SCOTT

Rutland Road and E. 45th St.

Tel. 2800 Bedford

BROOKLYN, N. Y.

NEP. WHITMANI

2 1/4 in., \$5.00 per 100

NEP. WHITMANI

3 1/2 in., \$25.00 per 100

BOSTON FERNS

2 1/4 in., \$3.00 per 100

H. H. BARROWS & SON Whitman, Mass.

ORCHIDS

We advise the Growers and Private Places that our Importations will begin to arrive in a few weeks' time and we will have the following: C. gigas, C. gigas Sanderiana, C. Mendelli, C. Schroederiae, C. Trianae, C. Gaskelliana, C. Percivaliana, C. aurea, Miltonia vexillaria, C. Mossiae, C. speciosissima, C. labiata and others. We guarantee that our plants will be extra fine with no disease or Cattleya fly and will quote the Lowest Prices in America.

ORDONEZ BROS., MADISON, N. J.

ORCHIDS

Largest Importers, Exporters, Growers and Hybridists in the World

Sander, St. Albans, England
and 235 Broadway, Room 1
NEW YORK CITY

Imported Orchids

JUST TO HAND

Laelia Purpurata, Cattleya Intermedia, Cattleya Mossiae, Cattleyas Trianae and Mendellii, Dendrobium Wardianum, Oncidium tigrinum and splendidum.

JULIUS ROEHR'S CO.,

The Orchid Nurseries RUTHERFORD, N. J.

ORCHIDS for Spring Delivery

NEW IMPORTATIONS

Cattleyas, Laellias, Oncidiums, etc.

WRITE FOR PRICES

Now is the time to Pot Orchids. Best Quality of Peat, Moss and Baskets on hand.

JOSEPH A. MANDA, 191 Valley Road, WEST ORANGE, N. J.

Prices Quoted in these Columns are for Dealers Only. When Writing to Advertisers Please Mention HORTICULTURE.

Notes from the Arnold Arboretum

The most beautiful of the trees and shrubs now in bloom at the Arboretum are without doubt the different species and varieties of *Prunus*, particularly the Japanese cherries. One of the handsomest of them is the graceful *Prunus pendula*, the Japanese Weeping Cherry, whose slender pendulous branches are densely covered with pale pink flowers. A variety with upright branches is *P. pendula* var. *adscendens*, introduced into cultivation under the erroneous name *P. subhirtella*; its flowers are exactly like those of *P. pendula* and are produced in equal profusion. Much larger flowers of a deeper pink color has *Prunus serrulata*, usually confounded with *P. Pseudocerasus* which is easily distinguished by the pubescent leaves; the pink color of the flowers is enhanced by the purple tinge of the unfolding foliage and the tree is of vigorous growth much resembling in habit the Sweet Cherry. Of the numerous beautiful varieties cultivated in Japan of *P. serrulata* and of the true *P. Pseudocerasus* varying with single or double flowers and from pure white or yellowish white to deep pink there are only some small plants in the Arboretum; they do not seem to be as hardy as the single-flowered pink *P. serrulata*. Among the peaches and almonds with their large pink flowers *Prunus Persica* var. *albo-plena* attracts attention by its large pure white double flowers which as double-flowered varieties usually do flowers a little later than the type. As the first of the American plums *Prunus nigra* has begun to bloom; it is handsomer in flower and of more vigorous habit than the closely related *P. americana* and blooms about two weeks earlier; the white flowers have a slight reddish tinge owing to the red calyx. Of Old World species *Prunus cerasifera* (*P. Myrobolana*, *P. divaricata*), *P. dasycarpa* supposed to be a hybrid of *P. cerasifera* and *P. Armeniaco*, are now in bloom and also *P. avium* begins to flower.

Magnolia stellata and *M. Kobus* are now past their prime, but *M. Yulan* with its large and showy white flowers is now in full bloom and the many forms of *M. Soulangeana*, hybrids of *M. Yulan* and *M. obovata* are beginning to flower: their tulip-shaped flowers range in color from almost pure white to purple and the plants differ also in the time of flowering and in the degree of hardiness: as a rule they are less hardy than *M. Yulan*, but hardier than *M. obovata* (*M. purpurea*, *M. denudata*) which cannot be successfully grown in the neighborhood of Boston.

The earliest of the Shadbushes and also the handsomest is *Amelanchier canadensis*; the pendulous racemes of the feathery white flowers on the spreading slender branches with the white color softened by the reddish tinge of the unfolding leaves give the whole flowering tree the appearance of a white misty cloud hovering among the almost bare branches of the other trees; usually *A. canadensis* is a tree, but there are also some very fine shrubby forms at the Arboretum. Only a little later than *A. canadensis* the closely related *A.*

obovatis (*A. canadensis* var. *obovatis*, *A. Botryapium* Britt.) begins to flower; it is a roundheaded shrub planted rather extensively in the Arboretum. The grayish pubescent unfolding foliage give the flowering shrub a soft grayish white appearance by which it is easily distinguished at a distance from the hard pure white color of other white flowering trees and shrubs. *Amelanchier spicata* is an allied species of more strictly upright habit and flowers still later.

Spiraea arguta, a hybrid of *S. Thunbergii* and *S. multiflora*, is without doubt the most beautiful of all the early flowering Spiraeas with its graceful habit and its wealth of pure white flowers. *Spiraea Thunbergii* is much less free-flowering, but is handsomer in foliage which has a light green feathery appearance and turns a clear yellow in autumn.

The earliest of the Honeysuckles, *Lonicera fragrantissima*, has opened since some time its small, but deliciously fragrant pinkish white flowers. Its branches however are still almost leafless, while most of the Honeysuckles belong to the early leafing shrubs. *Lonicera tatarica*, *chrysantha*, *coerulea* and others clothed with their tender young foliage form now a conspicuous feature in the shrubberies. Of those which are now in bloom *L. gracilipes* is the most attractive with its red flowers, though the flowers are less showy than the scarlet pendulous cherry-like fruits which appear in June. *Lonicera coerulea*, *L. ciliata* and *L. Altmanni*, a species from Turkestan of recent introduction, have rather insignificant yellowish white flowers.

Besides the Honeysuckles most species of *Ribes* belong to the early leafing shrubs and are already densely clothed with bright green foliage; of those now in bloom as *Ribes cereum*, *R. divaricatum*, *R. setosum*, *R. burejaticum*, *R. stenocarpum*, *R. rubrum*, *R. alpinum* and *R. pinetorum* only the last named, a species from Arizona and New Mexico and still very rare in cultivation, is noteworthy for its flowers which are orange red, a color very unusual for a *Ribes*: the others have white or pinkish white to greenish, rather small flowers.

Alfred Rehder.

Notes from York Experiment Station, York, Nebraska

LILACS

One who has never seen a large collection of these beautiful shrubs in all their varieties of form and bloom can have no conception of their beauty. There are now one hundred and fifty named sorts. I had the privilege of seeing them all in the Arnold Arboretum at Boston.

We have about fifty varieties here and Professor Sargent, who has charge of the Arnold Arboretum, sent us about twenty-five new sorts, so that now we have the finest collection in all the West. Most of these are now in bloom and they present a splendid spectacle. They vary in the form of the foliage and also in the flower. Some are single and some are double. Prominent among the new sorts are the Rouen in two varieties, the purple and the white. All are acquainted with the old

Persian lilac, but we have succeeded in getting a lot of white Persians, and also a hundred or so of the Siberian white lilacs. These, of course, will be extremely hardy and they are now covered with bloom.

Among those that make a fine showing are Alba Grandiflora, very large, pure white; Charles X, a reddish purple; Frau Danmann, very large panicles, flowers pure white; Marie Legraye has also great clumps of pure white flowers. This variety is very valuable for forcing in the spring. Then there is Professor Sargent, with buds of cherry red and dark violet when fully open.

When we come to double varieties, we have Charles Joly, a very dark reddish purple, a superb flower. Emile Lemoine has very large rosy lilac blooms; Jean Bart is simply a magnificent flower of rosy carmine; Madame Lemoine is white; President Grevy is a beautiful blue with flowers very double, one of the finest; and there is Senateur Volland with a compact head of blossoms which are rosy red.

There is a family of summer-blooming lilacs. There is the Hungarian lilac called Josikaea, then the Emodi, next comes Dr. Brestschneider and then we have Villosa from Japan. These four varieties have a different system of leaves from other kinds. The leaves are very large, often as large as a lady's hand, the bushes often being crowned with great masses of flowers. This is especially true of Villosa. At first, you will not be particularly impressed with it, but some summers, the whole bush will be one vast bouquet of charming bloom, one of the most striking things in the ornamental family.

Added to these are two other summer bloomers which are the tree lilacs of Japan and China. Now, these are trees, not shrubs. We have some here, ten years old, large enough for fence posts, and fifteen feet tall. They grow almost as fast and nearly as large as our native ash tree. When you see a good sized tree covered with a great mantle of snowy, honey-scented flowers, you can have some conception of its magnificence. What a splendid show for lining a walk or driveway such a tree would be. This lilac has rather delicate stems, often taking a pendulous or drooping form and it has small and delicate leaves. The Japanese tree lilac is of a sturdy kind and the leaves are larger. It is more symmetrical in form than the Chinese. These six summer bloomers certainly make a great addition to our parks and private grounds.

We are now engaged in originating new sorts. That is done by saving seeds of those growing near together so that the bees will fertilize the blossoms and in this way we get new and striking varieties. We have now over one thousand plants on the way and we are sure of some fine varieties in the lot but nothing as yet to compare with what we hope to produce.

We of the West have not the variety of ornamental trees and shrubs which they have in the East, and yet there are over one hundred kinds of lilacs that are perfectly hardy here in Nebraska, so there is no lack whatever in material for fixing up our home grounds.

C. S. Hammond

"Dreadnaught" Rhododendrons

I am very much indebted to Mr. Koehler for his friendly criticisms under the heading, of "Iron Clad Rhododendrons," although I do not remember having used this particular expression. While Mr. Koehler's notes are interesting, and in a certain sense instructive, they are by no means convincing, because, it is obvious that most of the varieties which he lists in such a clear and concise manner, have been favored more by repute than by the actual experience of some of our best known rhododendron growers.

Mr. Koehler writes so convincingly concerning his subject that I almost find myself unable to treat him to any serious criticism. I can quite understand that when he penned his comments under the more or less imposing title of "Iron-Clad Rhododendrons," he was filled with a burning desire not only to correct what might be an error in the wording of the sentence quoted, but also to obliterate entirely the list of varieties which I gave. He has been singularly unfortunate in his attempt.

Now, I do not like to criticise those people who, it seems, are better learned than myself or even those who apparently possess a superabundance of superior knowledge, but really, Mr. Koehler, I must ask you a question, which you may digest and answer at your leisure.

In the first place I would ask what constitutes a hardy rhododendron? My answer would be that any variety which is given a suitable situation, and a fair amount of winter protection, and proves satisfactory after a five years' test, must be considered hardy. It does not necessarily follow that because a variety is considered hardy it can be planted in the middle of a ten-acre field. If this is Mr. Koehler's conception of a hardy rhododendron, then I withdraw my entire list and say that they are all very, very tender indeed, and I also put the word tender behind every variety in his own list. "There is no iron-clad list in the sense that that term can be applied to a common lilac." Quite so, Mr. Koehler. Then if this is the case in a nutshell, all rhododendrons must be more or less tender and none can be termed iron-clad varieties in the correct meaning of the word.

I am, however, digressing somewhat from my chief object in penning these lines. My principal object was to point out, and impress upon Mr. Koehler the important fact that the readers of HORTICULTURE are not limited by any means to "Boston and vicinity." This progressive journal, it is pleasing to know, has a very wide circulation, much wider than Mr. Koehler has been aware of when he constructed his fleet of iron-clads for Boston and vicinity.

In my previous article I did not mention Boston and vicinity; for Mr. Koehler's benefit, however, I will give a few notes on varieties which I have had experience with in this particular locality, confining myself to the varieties at present under discussion. I have found that in the vicinity of Boston the following varieties will survive an average winter, without any overhead protection: Alex Dancer, Charles Bagley, August Van Geert, Hannibal, Everestianum and Concessum. The remainder, namely Lady Eleanor Cathcart, Mrs. A. Waterer, The Queen, Mrs. R. S. Holford and Mrs. John Clifton have proved after a five years' test to be quite

hardly in most locations, "providing they are fairly well protected in winter." See concluding paragraph in previous article. At this period an account of how we handle certain varieties, is quite unnecessary where rhododendrons are concerned, we find the intelligent gardener, no matter whether he is in the vicinity of Boston or any other part of America, will set about to achieve his object unostentatiously and allow the result to prove so far as he is personally concerned, which varieties are hardy and which are tender. A list of iron-clad varieties is always a very interesting document to have beside one. There will always remain however a certain percentage of progressive and enterprising people who deviate from the beaten track of the printed

list, by importing direct from Europe varieties which though not iron-clads are yet in a practical meaning of the word perfectly hardy. Those people I have frequently noticed have been successful with some varieties, with which others, "even experts," have failed.

The title "Dreadnaught Rhododendrons," I most respectfully append to Mr. Koehler's list, for his kind consideration and valued approval.

Wm. W. Brown

North Easton, Mass.

A Practical Screen



Very frequently there is need of a screen, and in all such cases the need is urgent. If it were possible to advertise for such a thing ready made, and be sure of getting it, the "ad" would run something like this: "Wanted at once, a screen. Must be of shimmering green leaves from the ground to the top. Must be impenetrable; must be very cheap; must take care of itself; must be sightly in summer as well as in winter." That might read like the ravings of a crazy man but it is far from it as I have the solution of the subject in my back lot and it answers the requirements of the "ad" to a dot, and a little bit more.

I needed a screen and I wanted it badly. There were many things to use but I decided on the Carolina Poplar. I put in a row of these and cut them back well. In front of these I planted Viburnum Opulus. The poplars got very busy growing and after a few severe cuttings they kept sending out new wood down to the ground. In the second year they were ten feet high and densely leaved. As a screen it answered all requirements, but since that time the viburnums have been growing and during the

winter months they furnish a gorgeous decoration of vivid red berries that hang until the leaves again shoot out.

It may be objected that the poplars are undesirable for many obvious reasons. Sure they are under some treatment but if you want a screen of moderate height you must cut them hard to get the new wood and by this cutting you also fool the borers. A sharp spade will keep the roots at home but beyond this there is no work. If you let the trees have full swing they will in a short time get on very friendly terms with the family and walk right into the house too and later dump a ton of dead wood on the house when they have grown up a hundred feet. But if you want a screen, plant the Carolina Poplar and give it the knife good and hard. For an artistic proposition put the viburnums in front.

Hubert Doogue

HORTICULTURE

VOL. VII

MAY 9, 1908

NO. 19

PUBLISHED WEEKLY BY

HORTICULTURE PUBLISHING CO.
 11 Hamilton Place, Boston, Mass.

Telephone, Oxford 292

WM. J. STEWART, Editor and Manager

SUBSCRIPTION PRICE

One Year, in advance, \$1.00; To Foreign Countries, 2.00; To Canada, \$1.50

ADVERTISING RATES

Per Inch, 30 inches to page \$1.00.
 Discounts on Contracts for consecutive insertions, as follows:
 One month (4 times) 5 per cent.; three months (13 times) 10 per cent.;
 six months (26 times) 20 per cent.; one year (52 times) 30 per cent.
 Page and half page spaces, special rates on application.

Entered as second-class matter December 8, 1904, at the Post Office at Boston, Mass.,
 under the Act of Congress of March 3, 1879.

CONTENTS

	Page
COVER ILLUSTRATION—Carnation Bay State.	
NOTES FROM THE ARNOLD ARBRETUM—Alfred Rehder	621
NOTES FROM YORK EXPERIMENT STATION—C. S. Harrison	621
"DREADNAUGHT" RHODODENDRONS—Wm. McMillan Brown	622
A PRACTICAL SCREEN—Luke J. Doogue—Illustrated	623
OBITUARY—George Moore, Portrait—August L. Ehrle—John O'Brien—Miss Nina Holton—Alonzo Henricks	625
A SINGULAR CARNATION FLOWER—W. E. Hall—Illustrated	625
NEWS OF THE CLUBS AND SOCIETIES:	
National Flower Show Committee—Florists' Club of Philadelphia—New Jersey Floricultural Society—New Haven County Horticultural Society—Tarrytown Horticultural Society—May Flower Show at Boston	626
Club and Society Notes	627
WINTER FLOWERING SWEET PEAS—Wm. Sim	628
SEED TRADE	630
SAN JOSE SCALE	630
MARYLANDERS IN HOLLAND—R. Vincent, Jr.	632
OF INTEREST TO RETAIL FLORISTS:	
A Detroit Retailer's View—Frank Danzer	634
New Retail Flower Stores	635
FLOWER MARKET REPORTS:	
Boston, Buffalo, Chicago, Detroit, Indianapolis, New York, Philadelphia, Twin Cities, Washington	637
MISCELLANEOUS:	
Personal	627
Twin Cities Planting and Park Notes	627
Business Changes	627
Publications Received	627
Daphne cneorum	628
Plant Imports	631
Buddleia variabilis Veitchiana	632
News Notes	635
Incorporated	635
A Prosperous Boiler Manufacturing Concern	645
Greenhouses Building or Contemplated	645

Amidst all the doubts and apprehension attendant upon the adverse business season through which we have been passing one encouraging fact which has stood out conspicuously is the unprecedented activity in the retail seed trade. We have yet to learn of a single instance of a well-managed seed house reporting a falling off in business as compared with one

year ago. Mail order houses have also enjoyed a tremendous demand which started early in the season and has continued without any slack and, as the weeks move along, it becomes more and more evident that the nursery trade as a whole has found things very much better than was expected. These facts must be accepted as reflecting the confidence prevalent in that section of the general public known as the middle classes. It is very plain that they find no special occasion in existing conditions for the exercise of exceptional frugality.

The electric van in horticultural trade

During the Easter season just past the plant dealer having an electric delivery van at his disposal enjoyed a great advantage. To maintain such an outfit is, however, quite expensive, and only the larger concerns with business enough to keep a chauffeur constantly occupied can afford to invest under present conditions. It is not alone their value as compared with horse power that makes these motors so desirable in horticulture but the fact that they afford a means of competition with the transportation companies. It is to be hoped that in the near future the cost of these machines and methods of operating them may be brought well within the reach of the small grower and the trade thus rendered independent of the railroads and their exactions. Complaints that have reached us from several suburban sources indicate that conditions as to express service are constantly growing more unsatisfactory.

An unequal struggle

One does not need to go far in the neighborhood of any of the larger cities in the older settled parts of the country to encounter greenhouse establishments which, a few years ago, were yielding a good income to their owners but are now totally inadequate for the purposes to which they were formerly devoted. At the time when these structures were erected money was easily made in rose growing, one or two wooden-frame houses often furnishing a livelihood for an industrious grower and his family. That, in time, competition and overproduction would bring market values down, down, down, that buildings would rapidly depreciate in efficiency from age and decay and demand a heavier repair expenditure each year, that enterprise and ingenuity would in time introduce structural improvements brought about through experience and better mechanical skill and thus put the later-built houses far ahead in efficiency and place the older establishments at a great disadvantage seems in many cases to have been overlooked; the forethought which would have laid aside a liberal percentage of each year's income for the inevitable reckoning day was not exercised and today the pathetic ruin tells the story. Bedding plants, small ferns, forcing bulbs, are still possible but one by one these places once conspicuous for rose growing must drop out of the unequal struggle in which they made so proud a start and the outlook for their owners is far from encouraging if nothing has been accumulated against this contingency. The big steel-ribbed factory with capital back of it seems to have taken the right of way.

Obituary

George Moore.

George Moore, whose death was briefly noticed in last week's issue of this paper, was born in Perry Barr, Staffordshire, England, about three miles from Birmingham, on June 5, 1826, in the house in which his ancestors had lived for over 100 years and where all his own children were also born. His father, John Moore, was a skilful nurseryman and farmer and George grew up in and followed the business, becoming partner in the firm of John Moore & Son. Both father and son were enthusiastic in the science of horticulture and people came miles to see their magnificent displays of standard roses, rhododendrons, etc. Mr. Moore was especially fond of the rhododendron and, in cooperation with his intimate friend when a young man—John Millmore, the raiser of *Erica Willmoreana*—raised many crosses between the Asi-



GEORGE MOORE

atic and American species, one of which, named *Mooreii*, won the first-class certificate of the Royal Botanic Society. This, with many thousands of other rhododendrons which he had, was killed on one terrible Christmas eve, about the year 1860, when the thermometer fell to 15 degrees below zero after an exceptionally warm season, and the resultant havoc involving the loss of the labors of many years was the direct cause of Mr. Moore's crossing the ocean with his family to make a new home in America. Soon after his arrival in Boston he followed the late C. M. Atkinson as superintendent of one of the departments at Hovey's nurseries at Cambridge, where he had as pupil and assistant Jackson Dawson, then a young man just returned from service in the war for the Union. Later he was employed at J. W. Manning's nurseries at Reading, Mass., and then as superintendent for E. M. Wood at the Waban Rose Conservatories, Natick. In 1879 he went to Montreal and for a time was in the florist business, but his heart was in the growth and culture rather than

sale of flowers, and in time he became English Lecturer to the Farmers in the province of Quebec, and later assistant editor of the *Journal of Agriculture* of this province, both of which positions he held until death.

Mr. Moore inherited his attachment for the science of horticulture through four generations. He loved his profession and those engaged in it, and the teaching of agriculture and horticulture in the public schools was a subject very dear to his heart. At the time of his death two books which he had written for use in the public schools were practically completed, and there is a strong sentiment in favor of their publication by the government. He was an occasional contributor to *HORTICULTURE*, as our readers know.

Mr. Moore possessed a wonderful memory. He never grew old though attaining the age of nearly 82. This was greatly due to the fact that he was always a student ready to give ear to any new scientific developments. An optimist he certainly was, and his geniality made him a great favorite with young and old. He married in 1849 Mary Ann, daughter of Captain Edward Moore of London, whom he survived but eighteen months. He leaves a family of five: Mr. John F. Moore of Allston, Mass., Miss M. C. Moore of Framingham Normal School, Mrs. Herbert Shattuck, Hopdale, Mass., Mrs. Herbert A. Baker and Mrs. Setimus Fraser of Montreal, P. Q. He died at his daughter's home in Montreal, and was buried at Hopdale, Mass.

August L. Ehrle.

We regret to have to report the death of August L. Ehrle, at Carlstadt, N. J., on April the 28th. Mr. Ehrle contracted a severe cold in his throat twelve months ago which caused his untimely death.

Mr. Ehrle had been employed by The Julius Roehrs Company in their orchid department for twelve years. Beginning when only a boy the love of orchids grew upon him until these charming flowers became a part of his existence. Being of a genial nature he was loved by all who knew him. He was 26 years old. He leaves a wife, who has the sympathy of all his friends.

John O'Brien.

John O'Brien, tree warden and florist, died in Lenox, Mass., on April 30. Mr. O'Brien was born in Kilworth, Ire., April 18, 1840, and came to Lenox forty years ago, being in charge of the Kneeland estate for many years. Later he established greenhouses on West Street where he conducted a successful business. Five sons and four daughters survive him.

Alonzo Henricks.

Alonzo Henricks, seventy-six years old, horticulturist at the Government Hospital for the Insane, Washington, D. C., for the past forty-five years, died on April 23. A wife, six sons and three daughters survive him.

Miss Nina Holton.

Miss Nina Holton of Newburyport, Mass., a member of the staff of the Bureau of Plant Industry, Department of Agriculture, died in Washington, D. C., on May 5.

A SINGULAR CARNATION FLOWER.

Editor *HORTICULTURE*:

I send herewith a few photographs of a red carnation seedling which made its appearance with me some time ago. It has a duplex calyx and flower, and perhaps will interest our brother florists and carnation breeders. With twenty-five years' experience in growing and breeding the carnation I never saw nor heard of one being produced like this one. Perhaps



Flower on 4 1-2 inch Measuring Card.

others have, and if so I hope this will bring out something interesting. Let it be a "freak" or not, grand, good Nature produces some wonderful things. The size of the flower across under the petals is 4 1-2 inches, which covers the outer line of the carnation measuring card, as can be seen in the photograph. The makeup of flower is not over-crowded with petals but it has 99 of them, full centre, round, fringed like a double poppy and measurement over the top of flower 7 1-2 inches. The outside calyx is 1x1 1-4 inches, inside calyx 5-8x1 1-4 inches. The lower half of stem is as large as an



Showing Double Calyx.

ordinary lead pencil. One peculiar characteristic is that the stamens come out of the inside calyx, and the anthers come out of the outside calyx. The inner calyx is not visible at any time, neither when the flower is opening nor when fully developed; the inner calyx serves to prevent this extra large flower from bursting. The flower with stem weighs 2 1-2 oz., more than double the weight, also double the number of petals, of the ordinary large carnation.

Very truly yours,

Clyde, O.

W. E. HALL.

NEWS OF THE CLUBS AND SOCIETIES.

NATIONAL FLOWER SHOW COMMITTEE.

About forty members attended the meeting of the Committee of Fifty in the Art Institute, Chicago, March 26. Chairman W. F. Kasting presided and reports showing that great interest prevails in the show and rapid progress is being made in preparing for it, were made by W. N. Rudd, chairman of the premiums committee; E. G. Hill, chairman of the foreign exhibits committee; Otto Koenig, chairman of the special features committee; Philip Breitmeyer, chairman of the American exhibits committee, and J. C. Vaughan, chairman of the local management committee. A report from the treasurer showed that a large number of the guarantors had paid a first assessment of 20 per cent. on their subscriptions. Chairman Kasting appointed Albert T. Hey of Springfield, Ill., a member of the committee in place of the late P. J. Hauswirth. The secretary reported that 1500 preliminary premium lists had been mailed, and more were on hand and ready to be sent to all who addressed a request to Room 1411, First National Bank building, Chicago. The American Carnation Society, the American Rose Society, the Chrysanthemum Society of America and the Horticultural Society of Chicago have offered their medals liberally as special prizes. W. N. Rudd, chairman of the premium committee, reported that \$2,336 in special premiums has been offered by various private persons and firms, together with about \$800 in medals and cups. The premium list offers a total of \$11,023 in prizes.

Committees have been appointed by the various chairmen as follows:

Executive and finance: W. F. Kasting, chairman; Philip Breitmeyer, E. G. Hill, W. N. Rudd, J. C. Vaughan, Otto Koenig, August Poehlmann, J. A. Valentine.

American Exhibits: Philip Breitmeyer, chairman; F. H. Traendly, George Asmus, S. S. Skidelsky, Elmer D. Smith, Robert Craig.

Special features: Otto Koenig, chairman; Theodore Wirth, Leonard Kill, S. S. Skidelsky, Harry Papworth, J. F. Sullivan, W. L. Rock, A. J. Guttman, John Bertermann.

Auditing: J. A. Valentine, chairman; E. B. George, Roy F. Wilcox, Otto Koenig.

Local management: J. C. Vaughan, chairman; August Poehlmann, J. B. Deamud, W. N. Rudd, C. Cropp, Elmer D. Smith, J. E. Hauswirth.

Exhibits, foreign: E. G. Hill, chairman; J. D. Eisele, Carl Cropp, E. B. George.

At a meeting of the executive committee held the following day Mr. Kasting appointed George Asmus chairman of the publicity committee. James H. Burdett was made permanent secretary and newspaper representative

of the committee. The question of manager was discussed and the local management committee was authorized to engage one.

It was determined, after a lengthy discussion, to give visiting florists, not members of the S. A. F., in good standing, the privilege of purchasing a season ticket to the National Flower Show for \$1. Several amendments to the rules were proposed to the premium committee, the most important being that in all classes where it is deemed permissible an entry fee of \$1 be exacted from each exhibitor.

J. H. BURDETT, Secretary.

FLORISTS' CLUB OF PHILADELPHIA.

At the Florists' Club meeting on Tuesday evening, May 5, Edwin Lonsdale exhibited *Schizanthus Wisetonensis compactus*, a seedling grown by him at the Girard College greenhouses. In speaking of these plants he considered them good for the conservatory. The plant on exhibition he called a "seed sport," there being about two dozen of these plants raised from seed saved from last year's plants. The seed was sown November 19 and the plants came into bloom April 20th. The new type is much dwarfer than the old *Wisetonensis*, very compact and floriferous.

On being asked a question about a new Dryden geranium, Mr. Lonsdale stated that he had obtained an improved Dryden, by crossing with a bright scarlet known around here as "Dennison's seedling." The Dryden, Jr., as he called it, was much brighter in color and a better plant than the old Dryden.

The smoker that was to have been given on May 14th has been postponed to the June meeting.

At the June meeting Arthur Niessen of the Leo Niessen Co. will read a paper on Co-operation between wholesaler and retailer in time of overproduction.

NEW JERSEY FLORICULTURAL SOCIETY.

The regular monthly meeting of the New Jersey Floricultural Society was held at their rooms on May 1st. The floral display consisted of orchids from the well-known houses of Lager & Hurrell of Summit, Thomas Jones of Short Hills and Joseph A. Manda of West Orange; carnations grown by William Read from the Colgate estate, Spanish iris grown by Max Schneider, Canterbury bells by Charles Ashmead, alameda by John Hayes and antirrhinum by John Derwin.

The address of the evening was by Joseph B. Davis upon Cartography applied to landscape work, illustrated by many maps and pictures from the speaker's collection, and included some rare india proofs by Alexander Anderson from *The Downing* publications. The sketch, the finished drawing, enlarged and reduced, the delineation of trees, grass and herbage, and foreign and domestic work as treated for the past hundred years, were touched upon during the evening. It was decided to hold a summer recess.

JOSEPH B. DAVIS.

NEW HAVEN COUNTY HORTICULTURAL SOCIETY.

A meeting of this society was held on Tuesday, May 5th; a large attendance present. J. F. Huns read a very interesting and instructive paper on hardy ferns, of which he has under cultivation over 300 varieties. His paper was so instructive that the society voted to have it printed in full and distributed to the members. He was given a hearty vote of thanks. The society voted to hold a rose show in June. The preliminary schedules were distributed to the members present for the November exhibition. After business, the members adjourned to a smoker as guests of the bowling team, when the prizes were given to the winners as follows: High single, R. Watson; second single, Wm. Dickie; high average handicap, James Moore; second average handicap, W. Dickie; third average handicap, D. Ferguson; fourth average handicap, Wm. Symons; most marks, Jas. Bruce; second most marks, Wm. Dickie. After the distribution of the prizes, T. Pettit presented the captain, Thos. Nye, with a gold watch, fob and charm on behalf of the members of the bowling team.

TARRYTOWN HORTICULTURAL SOCIETY.

The monthly meeting of this society was held on April 24th. Three new nominations to membership were received, and James Stuart of Mamaronock and Wm. Brown of Ossining were elected active members. Donations to our prize fund are still coming, and to date five silver cups are offered for the November exhibition.

James W. Smith's prize for the best two flowering plants was won by Thomas Atchinson, gardener to Mr. Henry Segel, with a pelargonium and a calceolaria, both well grown specimens.

The feature of the evening was the talk on Water Gardens by Charles H. Tibbits. Mr. Tibbits is connected with the park department of White Plains, N. Y., and has had very satisfactory results with aquatic plants.

Subjects for next meeting will be Shrubs and Hardy Perennials.

L. A. MARTIN, Cor. Sec.

MAY FLOWER SHOW AT BOSTON.

The annual May exhibition of the Massachusetts Horticultural Society will be held at Horticultural Hall, Saturday and Sunday, May 9 and 10. A feature of the exhibition will be the displays of late-flowering bulbous plants, such as Darwin, Single, Bizarre and Rose tulips. There will be also exhibits of calceolarias, pelargoniums, pansies and other seasonable flowers.

Of interest in the display of vegetables will be the collections grown under glass the present year.

The exhibition, which is free to all, will be open Saturday from 12 to 6 and Sunday from 2 to 6 o'clock.

WAL. P. RICH, Secretary.

New Crop of Ferns — Decoration Day Stock

FANCY FERNS, \$1.25 PER 1000.

DAGGER FERNS, \$1.00 PER 1000.

Edward A. Beaven

Evergreen, Ala.

CLUB AND SOCIETY NOTES.

The Wayland Floral Society of Wayland, N. Y., will hold its second annual exhibition on August 11-12. This is already attracting much attention from the fact that a large proportion of the proceeds will be devoted to beautifying the local cemetery.

The annual report of the Society of American Florists and Ornamental Horticulturists for 1907 has been received from Secretary Rudd. The report fills 240 pages and is a credit to Mr. Rudd, who, from the circumstances attending his assumption of the office of secretary, had an exceedingly difficult task in the compiling of this document. The membership as recorded for December 31, 1907, is given as 876, of whom 719 are annual and 157 life members. A portrait of President F. H. Traendly appears as a frontispiece.

At a meeting on April 25 of representative fruit and vegetable growers of Council Bluffs, Iowa, and vicinity, the National Horticultural Congress was organized with these officers:—

President, J. P. Hess of Council Bluffs; vice-presidents, J. M. Bechtel of Hamburg, W. S. Keeline and W. G. Rieh, Council Bluffs; J. R. McPherson, O. L. Barritt of McClelland; secretary-treasurer, George W. Reye of Council Bluffs.

While the association will have charge of all arrangements and plans for the horticultural congress proposed to be held in Council Bluffs on December 10 to 19, its object also will be to promote the horticultural and allied interests.

PERSONAL.

A. L. Knight has taken a position in the nursery of Herbert Jackson, So. Gorham, Me.

Eugene Barker of Peak's Island is now working for A. W. Dyer, florist, of Portland, Me.

R. A. Griffith, florist, Lowell, Mass., has been named by Mayor Farnham a trustee of public burial grounds for a term of five years. Mr. Griffith has already served one year on this commission.

RUBBERS 4 inch pots. \$20.00 per 100, \$2.50 per dozen.

ARAUCARIAS Nice 4 inch stock, 40c. Larger 50c, 75c, \$1.00

BEDDING PLANTS Geraniums, 4 inch Single and Double Dryden, \$8.00 per 100. Other varieties at \$7.00 per 100. Salvia Zurich and Bonfire, Lobelia Kathleen Mallard and all other new and standard bedding stock in best quality at lowest market rates.

JOHN MCKENZIE

North Cambridge, Mass.

COLD STORAGE LILIES

COLD STORAGE LILIES, means that you can have Lilies all the year round. What are more useful, or give more character to the funeral piece than the Lily.

We have, and can deliver at any time cold storage Lilies—and can refer you to hundreds that are growing them, why not you?

LILIUM LONGIFLORUM GIGANTEUM is the only longiflorum that gives satisfaction from cold storage—we offer them as follows:—**LILIUM LONGIFLORUM GIGANTEUM** (repacked 6 to 8 inch bulbs 400 in a case, \$8.50 per 100, \$75.00 per 1000, case of 400 for \$30.00. 7 to 9 inch bulbs, 300 in a case \$9.00 per 100, \$85.00 per 1000, \$25.50 per case of 300. 9 to 10 inch bulbs, 200 in a case, \$14.00 per 100, \$130.00 per 1000, \$26.00 per case of 200.

ARTHUR T. BODDINGTON, Seedsman,

342 WEST 14TH STREET, NEW YORK CITY

500,000 Pansies Best Market Strain Grown

Grown from seed of our own raising, this strain is the result of over 25 years' careful selection, and for size, form and substance and wide range of color in clear, brilliant selfs and novel shades and markings they will be found unsurpassed. The colors are very evenly assorted and the growth is very strong and stocky. Full transplanted plants ready to bud and bloom.

Price, \$10.00 per 1000. Larger sizes, \$15.00 and \$20.00 per 1000
EXPRESS ONLY. CASH WITH ORDER.

I. E. COBURN, 291 Ferry St.,

EVERETT, MASS.

TWIN CITIES PLANTING AND PARK NOTES.

The cleaning up in the parks and parkways is in full swing, Mr. Wirth doing his best to have them look in good shape for the Park Superintendents' Convention next summer. The operation of dredging Lake of the Isle—by the way, the most picturesque lake we have here—is drawing a good many spectators. The contractor is working three different dredges. The first one, which goes ahead, throws up the dirt to form the shore and at the same time act as a dam in halting the mud and water which is pumped in behind to fill up the swamps. The pump used for that is a suction dredge with a 12 inch discharge pipe. The dipper dredge follows behind to fix up the shore lines and give them the proper slope to the water.

The setting out of roses in the new rose gardens has commenced and the plants should do well, as the beds have been prepared the best way possible, and the whole garden is so situated as to get the sun all day, but all round there is a natural growth of trees that will keep the winds off from almost every direction. The setting out of the trees and shrubs in the parks and on private grounds is well under way and according to the different nurserymen business is very promising.

Bedding plants in frames have suffered some from the last cold spell, when the thermometer went down to 15 one night, but the loss, mostly in begonias, can be made good yet, as we do not plant out until about the first week in June.

BUSINESS CHANGES.

Henry Matz has purchased the greenhouses of Felix Mense, Glen Cove, N. Y.

Weigel & Ujfalussy, successors to Emil Steffens, florists' supplies, New

York, are now located at 138 West 23th St.

PUBLICATIONS RECEIVED.

Annual Report of the Trustees of the Pleasure Driveway and Park District of Springfield, Ill. The documents included in this report and the illustrations and maps showing existing and proposed development are good evidence that Springfield's 250 acres of parks and boulevards are being well cared for and liberally supported. The total expenditure in four years for construction and maintenance is \$141,971.22.

AUCTION SALES
TUESDAY & FRIDAYS
AT NOON.

CARPET BEDDING, PLANTS, BAY TREES, PALMS, AND BULBS

W. ELLIOTT & SONS
42 Vesey Near Church
NEW YORK, N. Y.

TOWER HOTEL

Niagara Falls, N. Y.

is soliciting your patronage during the S. A. F. Convention.

Very truly yours,

M. J. HOENIG, Prop.

WINTER-FLOWERING SWEET PEAS.

(Read before the Gardeners' and Florists' Club of Boston by Wm. Slim.)

(Continued from page 411)

Types.

There are three types of the early sweet pea, the wavy or Spencer type, the common type with the broad, straight standard, and the incurved or hooded type. As yet the Spencer type seems to me a little soft for commercial purposes, but this fault may be remedied in new varieties. The standard which is wavy has not got the strength of the common type, and they fold together when they are bunched in such a way as to make them look small, although the flowers are larger than the common type. The common type although not so large as the Spencer type, is the best for commercial purposes; their stiff straight standards do not fold together, and the flowers remain open. The incurved or hooded are the least desirable; their flowers are incurved and look small beside the ordinary type. They, however, have very long, wiry stems, and some of the best fancy varieties are of this type. They also are very strong growers.

Hybridization.

Most of the varieties with the exception of the ones sent out first, are the results of crossing the early and late varieties. This is done at the time the two types are in bloom together. Mrs. Charles Totty, Mrs. Alexander Wallace, Mrs. George Lewis, Christmas Captain, W. W. Smalley and a number more are the results of crossing the two types. Varieties raised by crossing the early type with the same type are usually weak growers. It seems to take the blood of the late varieties to give them constitution. I noticed this the past winter on a batch of recessed Christmas; this was the Christmas crossed on the late flowering Blanche Ferry. There was about fifty per cent. of the old type among them, but the early flowering ones were very much stronger and produced stronger flowers on longer stems than Christmas and grew three feet higher.

Strains.

There are new strains of these peas in England, Germany and Algeria. I am unable to give much information about these as I have never managed to get any of the seed. I have seen the Algerian strain growing at Mr. Zvolanek's; they were not in flower then, but the growth and habit was identical to what we have here. He later sent me some of the flowers. They were of very poor color and variety; in fact they were certainly ten years behind what we have here now. Flowers of the English strain resemble the Algerian strain and Mr. Zvolanek says they are the same varieties or mixture he sold five years ago to the firms who are selling the seed. It is very hard for the raiser to hold the stock of any one variety, because it is sent to California to be grown along for seed, and while there the seed can be carried from one place to another.

Sweet Pea Society.

What we need here now is an American Sweet Pea Society for at the pres-

FINEST LOT OF HARDY HYBRID RHODODENDRONS

ALSO DWARF RHODODENDRONS
ANDROMEDA FLORIBUNDA

READY FOR IMMEDIATE SHIPMENT
ORDER TODAY

EASTERN NURSERIES, JAMAICA PLAIN,
MASS.

RHODODENDRONS, ANDROMEDAS, KALMIAS AND SPECIMEN EVERGREENS

JOHN WATERER & SONS, LD.

AMERICAN NURSERY

BAGSHOT, - - - ENGLAND

ent time there is nothing to prevent any one from selling sweet peas under any name he pleases. We have Earliest of All, Christmas Pink and Xmas Pink. These three varieties are the same in every particular. The selected Earliest of All is earlier than the other, but the flowers of all three are identical. There is Mont Blanc and Florence Denzer; these two are identical. There is also Zvolanek's Watchung, Burpee's Earliest White and White Bird; these are all identical. We have Flamingo and Christmas Red, which are identical and Sunbeams and Canary Bird which are also identical. Aside from keeping the names straight it would stimulate the growing of sweet peas, and no doubt many would go into the improving of them in the way the carnation men have done with the carnation. If a number would get together with this in view it would be hard to predict what the sweet pea would be like ten years from now. Just fancy what an exhibition you could have if a number got together and did as the carnation men have done. The sweet pea is everybody's flower, being within the reach of all. Thus far Mr. Zvolanek seems to be about the only one to improve this class. It is only a few years ago that the first of this type were seen; now he has practically all the colors found in the late varieties. I think great credit is due him for what he has accomplished. Putting aside Christmas Pink, Mont Blanc and Sunbeams he has raised practically all the other varieties in cultivation now. He is doing for this type of peas what Henry Eckford did for the late flowering section.

(To be Continued)

DAPHNE CNEORUM.

Walter Dunhardt in Moller's Deutsche Gartner Zeitung

This plant grows wild in the Schwabische Mountains, together with *Gentiana verna* and *Orchis militaris*,

and other Alpine plants. It grows in sterile soils, among pines and alders, making a patch of about twelve to fifteen feet. Cultivation is not difficult if rooted plants can be bought, but plants dug up in the wild woods and transplanted into the garden do not always give desired results.

The Daphne, like other shrubby Alpine plants, grows in a dry, stony location, but has roots that go very deep into the soil. The roots are pressed into the narrow spaces between the rocks, and it is therefore very difficult to dig up plants without breaking the roots.

RHODODENDRONS

Hardy Hybrids — 1½ ft., 2 ft., 3 ft.,
4 ft., 5 ft.

Box — All sizes Bush, Pyramid and Standard.

Roses — Large assortment, Hybrid and Climbing.

Herbaceous Perennials, 1,000 varieties

Send for General Catalog and Trade List

The NEW ENGLAND NURSERIES, Inc.
BEDFORD, MASS.

Hardy Rhododendrons, Azaleas, Clematis, H. P. Roses, Shrubs and Herbaceous Plants from our
HOLLAND NURSERIES

Prices Moderate

P. OUWERKERK, 246 Jane St., Weehawken N. J.
P. O. No. 1, Hoboken, N. J.

Berberis Thunbergii

18 to 24-in., 22 to 28-in., all well branched and good roots. 10,000 *Vinca Minor* (Grave Myrtle). 5000 Red Oak, 3 to 5 ft. Norway Spruce, 12 to 18-in.

OAK HILL NURSERIES, Roslindale Mass.

HARDY ROSES FOR THE GARDEN

Strong Field-grown Plants

The roses here offered are extra strong two-year-old field-grown blooming plants, which, if planted early, will give a large number of flowers the first year. They can be planted as early in the spring as the frost is out of the ground, and from that time until about the first week in May. We offer a grand collection of the best and choicest varieties, as follows:

HYBRID PERPETUAL OR JUNE ROSES

Frau Karl Druschki, Marchioness of Londonderry, Capt. Hayward, Mrs. R. G. Sharman-Crawford, Ulrich Brunner, Margaret Dickson, Baron de Bonstetten, Paul Neyron, Gen. Jacqueminot, Magna Charta, Mrs. John Laing, Mme. Gabrielle Luizet, Marshall P. Wilder, Gloire de Paris, Baroness de Rothschild, Prince Camille de Rohan, Fisher Holmes, Alfred Colomb, Soleil d'Or, Persian Yellow, Moss Roses, Rugosa alba and rubra, etc.

MONTHLY AND HYBRID TEA ROSES

Etoile de France, Killarney, Mme. Abel Chatenay, Countess of Gosford, Koenigen Carola, Perle von Godesberg, Gruss an Tepiltz, Maman Cochet, White Maman Cochet, Belle Siebrecht, Hermosa, Mme. Caroline Testout, Souv. de Pres. Carnot, Kaiserin Augusta Victoria, American Beauty, La France, Clothilde Soupert, Prince de Bulgarie, Mme. Norbert Levavasseur (Baby Rambler), Anny Huiler (Pink Baby Rambler), Catherine Ziemet (White Baby Rambler), etc.

In Climbing Roses we have a nice stock of Crimson Rambler, Lady Gay, Dorothy Perkins, Dawson, Gardenia, Tausendschon, etc.

LET US KNOW THE QUANTITY YOU WANT AND VARIETIES, AND WE WILL BE GLAD TO QUOTE LOWEST PRICES ON SAME BY RETURN MAIL.

F. R. PIERSON CO., Tarrytown-on-Hudson, New York

ROSES

100 of the best Hardy sorts.

HYBRID PERPETUALS

Finest English Grown Plants

Dozen, \$3.50; 100 \$25.00

EVERBLOOMING HYBRID TEAS

Bloom from Midsummer until frost.

Dozen \$5.00; 100, \$35.00

Hardy Climbing Roses

All the leading sorts.

Catalogue Free on Application.

R. & J. FARQUHAR & CO.

6 and 7 So. Market Street,
Boston, Mass.

FORESTRY PLANTING

10,000 Red Oak, 4 to 6 in. \$60. Ornamental Planting, Swiss Stone Pine, 3 yrs., 3 to 4 in. \$3 per 100, \$25 per 1000. Foxtail Pine, 3 yrs., 3 to 4 in. \$4 per 100. Bal-four Pine, trunks, 4 and 5 in. \$6 per 100. Mugho Pine, trunks, 6 to 8 in. \$6 per 100. Compacta Mugho Pine, dwarf, trunks, 3 to 4 in., broad \$7 per 100. Hemlock, 6 to 8 in., trunks, \$4 per 100. Larger sizes of all of above. Am. Yew, 10 to 12 in., trunks, \$16 per 100. Specimens of Caroline Hemlock, Rk Mt. Spruce, Rk Mt. Silver Fir, 2 1/2 to 4 ft. \$3 to \$4.

JACKSON'S NURSERIES, Portland, Me.

LIVE FENCES

We believe we are the largest growers of Hedge plants in America—Privet our specialty—can supply any quantity both

Amoor River and California, strong plants, at \$25.00 per M. Other varieties. Prices on application.

PETER'S NURSERY COMPANY, - Knoxville, Tenn.

HARDY NORTHERN GROWN NURSERY STOCK

At Reasonable Prices

FRUIT AND ORNAMENTAL TREES, SHRUBS, VINES, ROSES AND HERBACEOUS PERENNIALS IN GREAT VARIETY

Catalogue and Price List for the asking

BAY STATE NURSERIES, NORTH ABINGTON, MASS.

NEW ——— NEW

RAMBLER ROSE "NEWPORT FAIRY"

To be disseminated Spring, 1908. Ask for illustrated pamphlet and prices

JULIUS ROEHRS CO., Rutherford, N.J.

The Roses that Win

MRS. POTTER PALMER, CARDINAL American Beauty and Other Standard Varieties. Rooted from Our Famous Stock. Send for Prices.

POEHLMANN BROS. CO.
Morton Grove, Ill.

ROSES

A SPECIALTY

The Dingee & Conard Co. West Grove PA.

RHEA REID

READY NOW, Own Root, \$30 per 100, Grafted, \$35 per 100.

AMERICAN BEAUTY

Fine Young Stock, \$6 per 100, \$50 per 1000.

THE E. G. HILL CO., Richmond, Ind.

AMERICAN NURSERY CO., COMBIN-ING

FRED'K W. KELSEY, New York City
F. & F. NURSERIES, Springfield, N. J.
BLOODGOOD NURSERIES, Flushing, L.I.
N J & L I. NURSERIES

We can supply your every need. Write for prices
Sales Department

150 BROADWAY, - NEW YORK

Seed Trade

Bulletin No. 121, from the Massachusetts Agricultural Experiment Station, entitled "Seed Separation and Germination," by Dr. George E. Stone, gives a brief account of the methods used in and the advantages to be derived from the separation of seed, together with some experimental data pertaining to seed separation.

The bulletin describes and illustrates the various devices for separating seed which have been employed at the Station. With large seed, sieves are recommended for separating the large from the small seed, and for smaller seed like onion a winnowing machine is used. The bulletin illustrates a new device for separating tobacco, celery and other similar very small seed by means of blasts of air, and this, as well as different kinds of sieves, etc., has been used extensively at the Massachusetts Experiment Station, and a great many samples of tobacco and onion seed are separated annually with it.

Tables are given in the bulletin showing the standard of germination of some of the most important seeds, and a brief review of the seed work at the Experiment Station. Four tables are also included which are for the purpose of illustrating the advantages of seed separation, and these are typical of a large number of experiments which have been carried on for some years, showing that in practically all cases the larger seeds are superior in their germinating capacity, and that from them much larger seedlings can be obtained.

Seed separation is especially applicable to tobacco and onion seed, and can be employed to good advantage with other seeds, more particularly lettuce, radishes and celery.

W. R. Paxson has opened a seed store at Crawfordsville, Ind.

THE SAN JOSE SCALE.

The Rhode Island College of Agriculture and Mechanic Arts has a bulletin now in press covering the subject of this dangerous pest very fully but it will not be ready for this spring's use and therefore an advance sheet is being distributed, from which we extract the following:

Its Dissemination.

The San Jose scale was imported from China into the San Jose Valley, California, about thirty-five years ago, and from there it has been carried over the country in nursery stock, almost before its dangerous character

SPRING FLOWERING BULBS			
PAEONIES		TUBEROSES	
	Each	Doz.	100
Extra Large Clumps with 4 or more eyes, Double White.....	\$0.15	\$1.50	\$10.00
Double Pink.....	.15	1.50	10.00
Double Red.....	.15	1.50	10.00
Festiva Maxima			
Double White, Streaked Red in Center, very early, fine for cutting.....		4.25	25.00
		MAMMOTH PEARL	
	Per	Per	
	100	1000	
First size.....	\$1.25	\$10.00	
Second size.....	.75	6.50	
CYCAS REVOLUTA			
25 lbs.....	\$2.25		
100 lbs.....	8.50		
300 lbs.....	24.00		
Headquarters for LIL. FORMOSUM			
Henry F. Michell Co.,		1018 MARKET STREET	Philadelphia, Pa.

was realized. Unlike the scurfy and oyster shell scales, which have troubled the fruit growers for a century or more, and which lay eggs in the fall of the year that hatch at some definite time the following summer, the San Jose scale lives over winter in the larval stage, and after maturing in the spring produces young which hatch from eggs inside the body of the female. This process may go on for five or six weeks before the insect dies. The larvae soon settle down, insert their sucking tubes into the bark and, in a few days, secrete a waxy covering or scale which protects them from injury. The young mature in about 35 or 40 days and then begin to give birth to a new generation.

The oyster shell and scurfy bark scales can be treated with an ordinary kerosene emulsion at the time when the eggs hatch in the early summer, and if thoroughly done, every one of the young scales will be destroyed. This method cannot be used for the San Jose scale. Solutions which would destroy the female scales would be too caustic for the foliage of the trees. It is possible to kill the young larvae with the same solutions as used for other scales, but it is evident from the life history already given that applications would have to be made once or twice a week throughout the summer in order to reach all that are born before they have time to form the protective covering.

Three Billion Descendants in One Season.

As the insect has few enemies, most of the young scale live to mature and reproduce, and with the several generations which appear during one season it is possible for one female which winters over to have more than three billion descendants at the end of the season. This illustrates the force of what we wish to impress upon all who expect to battle with this insect on fruit and ornamental stock, that spraying as ordinarily carried on, is inefficient and almost certain to lead to disappointment and the idea that the scale cannot be controlled. A very few scales which may escape a careless application of the spray remedy may have progeny enough to lead the fruit grower to think, when the fall comes, that the application of spray remedies the previous season was of absolutely no avail, when as a matter of fact he may have killed 95 per cent. of those wintering over.

The Best Spraying Outfit.

The precaution is obvious. Every portion of the tree must be covered with the spray to the very tips of the

twigs, and from all sides. This can only be accomplished with a good spraying outfit. The first requisite is a good spray pump with which a pressure of 75 to 125 pounds can be maintained at the nozzle. If the Vermorel type of nozzle is used, this pressure will produce a fine mist-like spray, which, if intelligently directed, will strike and adhere to all parts of the tree. As an illustration of the efficiency of a misty spray over a coarse one, notice how much more thoroughly a tree is damped by a heavy fog than by a brisk shower.

The best remedy today is the lime-sulphur wash prepared as follows: Slake 15 to 20 pounds of good lime in a small quantity of hot water. While the slaking is in progress, sift into the lime 15 lbs. of Flowers of Sulphur and mix the mass thoroughly. When the ebullition has ceased, add 20 to 25 gallons of hot water and boil from 40 to 50 minutes. Pour through a strainer having 20 to 24 meshes to the inch into a tank or barrel and add water, hot preferably, enough to make fifty gallons. The mixture should be applied while hot, and if any of it is left standing over night it should be heated before being applied.

When it is impracticable to make the lime-sulphur wash in any of these forms, good results can be obtained by the use of one of the miscible oil sprays now on the market. Scalecide and Trajet Brand Scale Emulsion are forms of these oil sprays which seem to give excellent results. They are handled by dealers in agricultural supplies in our cities. The oil sprays mix readily with cold water and are very easily applied. Directions for using are furnished by manufacturers.

Recapitulation.

To recapitulate: The spraying must be done with good spray mixtures and up-to-date apparatus. The work must be thorough. If a wind blows, only one side of the tree can be sprayed. The other side must be treated when the wind is from the other direction. Have pressure enough to produce a fine mist as the spray leaves the nozzle. Cover every spot on the tree to the very tip of the twigs. A good sprayer will do this without deluging the tree so that the liquid runs down the stem or drips from the branches. Use the boiled lime-sulphur wash if possible. If not, use one of the miscible oils. Spray as soon as the leaves have fallen in the autumn, or just before the leaves come out in the spring.

You will find something worth reading on every page of HORTICULTURE.



Aster Seed!! Have You All You Need??

If you still have an order to send:—DO NOT DELAY, SEND IT TODAY. We are now sold out of our Special Giant Comet. Some of the other varieties are almost sold out. All seed grown by us in 1907.

Aster Book and Competition Card for Great Aster Growing Contest, Free.

ALTIMO CULTURE CO., = CANFIELD, OHIO

PLANT IMPORTS.

Entered at New York, April 22nd to May 5th, 1908.

From Rotterdam: Wm. Elliott & Sons, 8 cs. plants; Maltus & Ware, 49 pgs. do.; P. Ouwkerk, 17 cs. trees; August Rolker & Sons, 3 bales plants. Sundry Forwarders, 7 cs. plants, 17 cs. trees.

From Antwerp: H. H. Berger Co., 2 cs. plants; H. F. Darrow, 39 cs. do.; John Dunn, Jr., 3 cs. do.; Ph. Kinsman, 14 cs. do.; 16 tubs laurel trees; O. G. Hempstead & Son, 57 cs. plants; Peter Henderson & Co., 2 cs. do.; McHutchinson & Co., 32 cs. do.; 283 tubs laurel trees; C. F. Meyer, 37 cs. plants, 4 tubs laurel trees; Maltus & Ware, 78 cs. plants, 70 tubs laurel trees; T. C. Pollock, 3 cs. plants, 14 tubs laurel trees; Julius Roehrs Co., 42 cs. plants, 36 tubs laurel trees; August Rolker & Sons, 70 cs. plants, 78 tubs laurel trees; J. TerKuile, 3 cs. plants, 30 tubs laurel trees; Vaughan's Seed Store, 128 cs. plants, 214 tubs laurel trees; Sundry Forwarders, 143 cs. plants; 124 tubs laurel trees.

Via Southampton: C. C. Abel & Co., 11 cs. plants; O. G. Hempstead & Son, 10 cs. do.; Maltus & Ware, 5 cs. do.

Via Liverpool: Sundry Forwarders, 4 bales rose trees, 9 cs. plants.

From Havre: E. A. Havemeyer, 1 cs. plants; Sundry Forwarders, 24 pgs. do.

From Marseilles: Wadley & Smith, 6 cs. plants.

From Germany: Otto Lindemann, 1 cs. live plants; Paragon Plaster Co., 2 pgs. trees.

XXX SEEDS

CHINESE PRIMROSE. Finest grown, varieties mixed; 500 seeds, \$1; half pkt., 50c.
CINERARIA. Finest large-flowering dwarf, mixed; 1000 seeds, 50c.
GIANT PANSY. Best large-flowering, mixed, critically selected; 5000 seeds, \$1; half pkt., 50c. Cash.
JOHN F. RUPP, SHIREPLANTSTOWN, PA.
 The Home of Primroses.

CAULIFLOWERS & CABBAGE

HJALMAR HARTMANN & CO.,
 12 Stormgade,
 COPENHAGEN, DENMARK.

Burpee's Seeds

PHILADELPHIA

Blue List of Wholesale Prices mailed only to those who plant for profit.

SURPLUS

Peas and Beans at attractive prices to close out surplus.
 40 bu. Peas, First and Best at \$2.25
 5 " " Alaska " 4.00
 20 " " Gradus " 4.50
 5 " " Nott's Excelsior " 3.00
 5 " " Premium Gem " 3.00
 15 " Beans, Currie's Rust Proof " 2.50
 10 " " Improved Golden Wax " 2.50
 15 " " Burpee's Stringless Green Pod " 2.50
 12 " " Red Valentine " 2.25
 8 " " Refugee " 2.25
 8 " " Wardwell's Kidney Wax " 2.50
 6 " " Mohawk " 2.25
 10 " " Dreer's Bush Lima " 5.00
Gladioli Bulbs, large No. 1, fine mixture, at \$4.00 per 1000.
Cauliflower plants, Early Dwarf Erfurt, nice stock, hardened ready for planting, at \$4.00 per 1000.
Cabbage plants, Early Jersey Wakefield, Early Summer and Large Charleston Wakefield, nice plants, hardened ready for planting, at \$2 per 1000, \$15 per 10,000.
Egg plants, Black Beauty and New York Improved Spineless, at \$1.00 per 100.
Strawberry plants, quality collection, 500 plants in five varieties early to late, for \$2.00. All above quick cash offer. Mention this paper. Address
W. F. ALLEN, 102 Market Street, Salisbury, Md.

RELIABLE SEEDS

SOW NOW

Ageratum Mexicanum Blue Star—
 Tr. Pkt. 25c; 6 Tr. Pkt., \$1.25.
Lobelia Erinus pendiculata Hamburgia
 Tr. Pkt. 30c; 6 Tr. Pkt., \$1.50.
Primula Obconica Grandiflora—
 New Hybrids: Blood-red, Blue, Carmine, Pink, Purple, Violet, Pure-white, Compacta, Gigantea, Fringed Mixed Hybrids, each separate, Tr. Pkt. 50c; 6 Tr. Pkts., \$2.50.

My Catalogue will guide you through Reliable Seeds. Ask for Same.

O. V. ZANCEN
 SEEDSMAN, HOBOKEN, N. J.

JUST ARRIVED

LARGE SHIPMENT OF
High-Grade SCOTCH SOOT.

We have the **Stott Double Nozzle**
THOMAS J. GREY CO.
 32 & 33 So. Market St., BOSTON

BRIDGEMAN'S SEED WAREHOUSE

RICKARDS BROS.

Props.
 37 East 19th St., - NEW YORK CITY

In ordering goods please add "I saw it in HORTICULTURE."

BRASLAN SEED GROWERS CO.

GROWERS FOR THE
 WHOLESALE TRADE ONLY
SAN JOSE, - - CALIFORNIA



Seeds of **ASPARAGUS PLUMOSUS NANUS**, \$2.00 per 1000.
 Seeds of **ASPARAGUS PLUMOSUS ROBUSTUS**, \$2.00 per 1000.
COLD STORAGE LILY OF THE VALLEY PIPS
JAPAN LILIES, JAPAN IRIS

For prices, state quantities required.

J. M. THORBURN & CO.
 33 Barclay St., through to 38 Park Place
 NEW YORK

Best Quality Fall Bulbs

It is to your advantage to place your order early. Send us a list of your wants and we will quote you rock-bottom prices. Copy of our Florists' Bulb Catalogue will be sent upon request. Catalogues now ready.

VICK'S SUPERB PANSY SEED

All the best varieties in separate colors
 VICK'S SUPERB MIXTURE

the best strain from all the leading named sorts
 1-8 oz. 75c. 1-4 oz. \$1.50 Ounce \$5.00

JAMES VICK'S SONS, Rochester, N. Y.

PRIMULA, FRINGED SINENSIS

This seed has been grown for us by a specialist in the culture of Primula, and he has produced plants of sturdy growth, large, thick flowers beautifully fringed and carried on erect stems well above the foliage; unexcelled in size, substance and beautiful colors.

Giant Pefection strain, Finest Mixed, 1-64 oz., \$1.00
 Pure White, Brilliant Pink, Blue, Chiswick Red, and
 Crimson, 1-64 oz., \$1.00.

H. E. FISKE SEED CO.
 13 Faneuil Hall Sq., BOSTON, MASS.

G. C. MORSE & CO.

Address all communications to our permanent address
 48 to 56 Jackson St., San Francisco, Cal.

The Largest Seed Growers
 in the United States

BRECK'S SEEDS

For Farmer, Market Gardener and Florist
 New Crop High Grade
 Catalogues mailed free on application

Joseph Breck & Sons Corp.
 47-54 NO. MARKET ST., BOSTON, MASS.

<p>Tobacco Paper IS THE STRONGEST, BEST PACKED, EASIEST APPLIED.</p> <table border="0"> <tr> <td>24 sheets.....</td> <td>\$ 0.75</td> </tr> <tr> <td>144 sheets.....</td> <td>3.50</td> </tr> <tr> <td>288 sheets.....</td> <td>6.50</td> </tr> <tr> <td>1728 sheets.....</td> <td>35.10</td> </tr> </table>	24 sheets.....	\$ 0.75	144 sheets.....	3.50	288 sheets.....	6.50	1728 sheets.....	35.10	<p>“NICO-FUME”</p> <p>Furnishes the Most Nicotine for the Money!</p> <p>... Manufactured by ... THE KENTUCKY TOBACCO PRODUCT CO., Louisville, Ky.</p>	<p>LIQUID OVER 40% NICOTINE By far the CHEAPEST.</p> <p>JUST NOTE PRICES!</p> <table border="0"> <tr> <td>Pint.....</td> <td>\$ 1.50</td> </tr> <tr> <td>½ Gallon.....</td> <td>5.50</td> </tr> <tr> <td>Gallon.....</td> <td>10.50</td> </tr> <tr> <td>5 Gallons.....</td> <td>47.25</td> </tr> </table>	Pint.....	\$ 1.50	½ Gallon.....	5.50	Gallon.....	10.50	5 Gallons.....	47.25
24 sheets.....	\$ 0.75																	
144 sheets.....	3.50																	
288 sheets.....	6.50																	
1728 sheets.....	35.10																	
Pint.....	\$ 1.50																	
½ Gallon.....	5.50																	
Gallon.....	10.50																	
5 Gallons.....	47.25																	

MARYLANDERS IN HOLLAND.
We have received from R. Vincent, Jr., of White Marsh, Md., who together with Mrs. Vincent, is accompanying the British Horticultural Press party on its tour through Holland, Belgium and France, the following interesting letter dated April 26 at Ghent, which will be read with pleasure, we are sure, by Mr. Vincent's many friends.
Editor HORTICULTURE:

Dear Sir,—We have arrived this far on our journey. The weather has been very cold and disagreeable, but we have had plenty of enjoyment on our trip through the bulb fields of Holland. The hyacinths were simply grand; the narcissi also. Tulips, except the early flowering kinds, were not in bloom, though showing fine growth. The extensive cultivation of every crop grown here shows the wonderful economic side of these people, who deserve all praise that they get, for their many and varied products.

At the banquet in Haarlem and also throughout that day's trip, the French buyers or dealers were also with us. At the banquet speeches were made in English, French and Dutch, about 250 plates being required for the visitors. The decorations both on the tables and stage were very elaborate, and a very enjoyable time was had.

I visited the Quinquennial Exhibition here today, and I must say that for size and beauty of decoration it beats anything that I ever dreamed of, both for quantity of various plants and blooms exhibited and the arrangement of same, which was simply marvellous, especially as to the color effect, a great many being so arranged as to show at their best.

I had always understood that this was the home of the azalea and rhododendron, but expected to find them smaller plants. It is true that there were a great many small plants exhibited, but the number of extra large ones of tremendous size was a surprise indeed, a large number of them being the flat or common round-head type, also of the espalier and pyramidal shaped. These plants were shown, some with two plants trained together so that a space or two of say a bright red one, would show out from a white base. All classes and varieties were shown, including several extra good blocks of Azalea mollis and pontica. Rhododendrons were certainly strongly in evidence, and gave color and enchantment to the exhibition of beauty. The main building was filled with palms, ferns, and stove and greenhouse

plants of all descriptions, making a scene long to be remembered. The collections of orchids, etc., was said to be one of the best exhibits ever put up. Ghent claims to have the largest and most extensive grower of these plants there is, and the money value of those exhibited is said to be something marvellous.

The grounds outside were filled with a choice assortment of bays, evergreens and all other plants that could stand to be planted out at this season.

Some fine beds of extra large daisies, pansies and other hardy flowering plants among the beds of specimen evergreens enlivened the scene. This vast show, with all the space covered was thronged continually with an admiring crowd, showing what a strong interest the people of Belgium take in beautiful flowers. In fact, all of the stores seem to think it necessary to decorate, some making their places of business look like a florist's shop. We leave tomorrow morning for Brussels and on Thursday for Paris.

Respectfully yours,
RICHARD VINCENT, JR.

BUDDLEIA VARIABILIS VEITCHIANA.

Emil Matzner, in Moller's Deutsche Garten Zeitung.

This plant was given into the trade, two or three years ago, by James Veitch & Sons, Chelsea, England. It is distinguished by a special strong growth, and has much larger flower stalks than the ordinary variety.

The Buddleia variabilis flowers on young wood and has to be cut back considerably. They are propagated easily by hardwood cuttings in October or November.

VEGETABLE PLANTS

CABBAGE Wakefield, L. I. Second Early, Early Flat Dutch, Early Summer, Wimingsstadt, and other late var. at \$1.00 per 1000, \$8.50 per 10,000.

BEEF Eclipse, Crosby's, Egyptian, at 25c per 100, \$1.25 per 1000.

LETTUCE Boston Market, Tennis Ball, Big Boston Grand Rapids, 20c per 100, \$1 per 1000.

CELERY White Plume, G. S. Blanching at 20c per 100, \$1.00 per 1000.

Cash with Order.

R. Vincent, Jr. & Sons Co., White Marsh, Md.



Cattle Manure In Bags Shredded or Pulverized

Best and safest manure for florists and greenhouse use, absolutely pure, no waste, no danger. Write for circulars and prices.

The Pulverized Manure Co.,
31 Union Stock Yards, Chicago

DON'T EXPERIMENT
USE
To-BAK-INE
and your stock will be free from insects, clean, and the blooms will not be discolored.

Send for full information of

W. W. RAWSON & CO.,
5 Union St., Boston.

STUMPP & WALTER CO.,
50 Barclay St., New York.

HENRY F. MICHELL & CO.,
1018 Market St., Philadelphia.

E. H. HUNT, Gen'l Agent,
76-78 Wabash Ave., Chicago.



The Best Bug Killer and Bloom Saver

For PROOF Write to

P. R. Palethorpe Co.
OWENSBORO, KY.



JAGER SPRAYERS

are money makers and money savers because they enable you to do the work right, with little labor and without wasting solution. We make an outfit for every need, from large Power Sprayers to small Hand Sprayers—each the best of its kind. **Special Sprayer Book Free**, illustrating and describing our complete lines. Investigation pays.
Chas. J. Jager Co., 241-3 Franklin St., Boston, Mass.
Branch: 33 Canal St., Providence, R. I.



Mr. FLORIST
Why Don't You Sell

VASES

Every vase sold means more business for you

This Business belongs to you

Will you let us show you how to get it?

Write for Catalogue "B" on VASES

The Kramer Bros. Fdy. Company
DAYTON, O.

Largest Fig. of Vases in the U.S.

Martial Bremond

WHOLESALE GROWER OF FRENCH BULBS

— OLLIOULES, FRANCE —

A superior quality supplied at market prices. Shipments made direct. Cases marked to order.

Sole Agents

RALPH M. WARD & COMPANY
12 West Broadway - - NEW YORK

CHRYSANTHEMUMS

All the Popular Varieties.
Rooted Cuttings, per 100, \$1.00; per 1000, \$8.00

GERANIUMS

A Large Assortment of the Choicest Kinds.
From 3 1/2 in. pots, \$7.00 and \$8.00 per 100.

FOR DECORATION DAY

40,000 LILIES, \$8.00, \$10.00 and \$12.50 per hundred.
25,000 SPIRAEA (cut), \$2.00 to \$4.00 per hundred.
HYDRANGEAS, 50c to \$5.00 each.

WM. W. EOGAR CO., Waverley, Mass.

ROSES

Strong, Clean Stock. Grafted, Killarney, Richmond, Brides and Maids \$12.00 per 100, \$110.00 per 1000. Own Roots, Brides, Maids, Gates, Ivory, Perle, Killarney and Richmond. \$6.00 per 100, \$55 per 1000. All from 3 1/2 in. pots.

P. R. QUINLAN, Syracuse, N. Y.

There are some GOOD BARGAINS listed in the BUYERS' DIRECTORY, Pages 640 to 644 this week.

HIGH GRADE DUTCH BULBS

W. J. ELDERINC & SON
Overveen, Haarlem, Holland

Special Quotations, on large quantities. Wholesale Only.

New York Address **HOTEL SEVILLE**

ROBERT CRAIG CO.
ROSES, PALMS,
and Novelties in Decorative Plants
MARKET and 49th STREETS., PHILADELPHIA, PA.

DAHLIAS.

Now is the time to place your order for bulbs which will insure you getting named varieties in any quantity; prompt delivery.

DAVID HERBERT & SON,
Successors to L. K. Peacock, Inc.
ATCO, N.J.

GERANIUMS

Good Strong Stock from 2 inch pots

Centaure, Double Gen'l Grant, El Cid, Miss Kendell, S. A. Nutt, Granville, Jacquerie, Mrs. E. G. Hill, &c., \$2.00 per 100, \$18.50 per 1000.

Alph. Ricard, Berthe de Presilly, Jean de la Brete, Alice of Vincennes, &c., \$3.00 per 100, \$25.00 per 1000.

Double Dryden, E. H. Trego, Peter Henderson, Telegraph, &c., \$4.00 per 100, \$35.00 per 1000.

Eugene Sue, Mrs. Lawrence, Paul Crampel, Mistral, Jean Oberlee, Col. Thomas, &c., \$6.00 per 100, \$50.00 per 1000.

Rose, Nutmeg, Oak Leaved and Balm, \$2.00 per 100.

SPECIAL OFFER—We have about 10,000 extra good strong plants, little lots of a kind, the accumulation of the season's odds and ends, single and double, which we offer as long as they last at \$15.00 per 1000, \$8.00 for 500, not less than 500 at this price. **These would make good stock for Decoration Day.**

S. A. Nutt, Double Gen'l Grant, La Pilote, Granville, and other good bedding kinds from 3-in. pots, \$3.50 per 100.

Pelargoniums, in good variety, 3-in pots, \$1.50 per dozen, \$6.00 per 100.

DAHLIA ROOTS

Whole field clumps, at \$5.00 per 100 and up; send for list of 75 varieties

HARDY CHRYSANTHEMUMS

A splendid collection of the very best 75 varieties, Small Flowered or Button \$2.00 per 100. Large Flowered or Aster type \$3.00 per 100.

DAHLIA PLANTS

From 2-in. pots, ready for immediate shipment at \$2.00 per 100 and up. We will send 1000 in 20 good varieties, our selection, for \$18.50.

	Per 100		Per 100
Ageratum, Stella Gurney	\$2 00	Hardy Phlox,	2.00
Begonia, Verano, White and Rose.....	2.00	Hollyhocks, Strong 3 in. pot plants, dbl, white, pink, red and yellow.....	3.00
" " Graeflis, White and Rose.....	2.00	Ivy Leaved Geraniums, 6 good kinds, \$25 00 per 1000.....	3.00
Begonias " Rex " from 2 in. pots.....	2.00	Lobelia, Crystal Palace Gem	2.00
Cuphaea, Cigar Plant	2.00	" Kathleen Mallard, 2 inch.....	3.00
Coleus, Verschaffeltii, Golden Bedder and other kinds	2.00	Lavender, 3 1/2 in. pots strong	3.00
Fuchsias, Black Prince and Minnesota..	2 00	Swainsona, Alba	2.00
Lieutenant Muritz, White and Rose Phenomenal	2.50	Tradescantia, Dark Variegated.....	2.00
Hardy English Ivy, Extra Strong. \$15.00 per 1000.....	2.00	Verbena, Red, White, Purple and Pink	2.00

R. VINCENT JR. & SONS COMPANY, White Marsh, Md.

AZALEAS

for fall delivery, the best that are grown, also

PALMS

for spring or fall delivery, furnished by Belgium; orders looked over.....

AUGUST HAERENS, Somergem,

ADDRESS THE AMERICAN REPRESENTATIVES
AUGUST ROLKER & SONS, 31 Barclay Street, or P. O. Box 752, New York

JOHN BREITMEYER'S SONS

Cor. Miami and Gratiot Aves.
DETROIT, MICH.

Artistic Designs . . .
High Grade Cut Blooms

We cover all Michigan points and good sections of Ohio, Indiana and Canada

William J. Smyth FLORIST

Cor. Michigan Ave. and 31st St., CHICAGO

We ship to all points in Illinois and Iowa.

Phones: Douglas 744, Douglas 523, Douglas 740

M. C. and J. E. HAUSWIRTH

232 Michigan Ave.
CHICAGO

AUDITORIUM ANNEX Tel. Harrison 585

SAMUEL MURRAY Florist

Coates House Conservatory
1017 BROADWAY, KANSAS CITY, MO
Both 'Phonas 2670 Mafn

FRED C. WEBER FLORIST

4326-28 ST. LOUIS, MO.
OLIVE STREET
Established 1873
Long Distance Phone Bell Lindell 676



WASHINGTON,
D. C.

GUDE'S

Geo. H. Cooke FLORIST

Connecticut Avenue and L Street
WASHINGTON, D. C.

The Park Floral Co.

J. A. VALENTINE
Pres.

DENVER, COLORADO

WILLIAM L. ROCK FLOWER CO.

KANSAS CITY, MO.

will carefully execute orders for Kansas City and any town in Missouri or Kansas.

Of Interest to Retail Florists.

Chas. Limmer, florist, has moved to 321 State St., Schenectady, N. Y.

Easter trade at Franklin, Mass., was fully up to previous years. Prices were maintained and everything was in good demand.

The Colonial Flower Shop is to occupy the new building to be erected on the corner of Main and Jefferson streets, Goshen, Ind.

L. C. Margot, florist, of Jamaica Plain, Mass., has recovered from his recent severe illness and is again able to attend to his business.

Mrs. H. B. Magee, who was one of the heavy losers by the Chelsea fire, has opened a flower store at 243 Bunker Hill St., Charlestown, Mass. Mrs. Magee had been established in Chelsea fifteen years.

A DETROIT RETAILER'S VIEW.

At this season of the year when our cut flower resources are for natural reasons far ahead of the demand we see all those products of Dutch origin, i. e., tulips, hyacinths, etc., go to the waste box in enormous quantities. In view of the enormous cash outlay Dutch bulbs involve and the small margin which exists between that and the returns from the wholesaler, we are naturally inclined to speak discouragingly concerning the bulb forcing industry. We are, in short, convinced that there is "nothing in it." We feel that the energy which the many dollars we send to Holland can produce would be more profitably expended at home. What other flowers could we grow in place of narcissi, tulips, hyacinths, etc., that would be just as welcome to the public and not reduce the demand for our home product such as carnations and roses?

But we all must concede that the position which bulbous flowers hold in our trade today is not one of unjustified usurpation but rightfully belongs to them. If they overstep their position and crowd our home product into the background it is not their fault but solely our own. While the growing of too many bulbous flowers may suggest itself as the first and primary cause of overproduction, I decline to accept the consideration of this fact for the reason that Americans will overwork anything and everything. More important and of better permanent remedial effect seems to me an endeavor to place bulbous flowers where they belong. If we realize their proper position in our trade the question of quantity is solved.

As we stand today we provide for the public a comparatively small bill of fare. Carnations, for instance, are nice and justly well liked, but if we have fifty varieties and we supply Mrs. X. with fifty table decorations, using a different variety every time, she will be dissatisfied. Here is where the bulbous flowers assume their eminently important position in our trade. It is up to them to give us the means to stimulate the sale of our home product. To offer every prospective purchaser carnations is simply killing the

Florists Out of Town

Taking orders for delivery in
New York or Vicinity
can have them filled in best
manner and specially delivered by

Thomas Young, Jr.

500 Fifth Ave., New York City
Telephone 847 Bryant.

ALEX. McCONNELL

571 FIFTH AVENUE
NEW YORK CITY

Telegraphic orders forwarded to any part of the United States, Canada, and all principal cities of Europe. Orders transferred or intrusted by the trade to our selection for delivery on steamships or elsewhere receive special attention.

Telephone Calls, 487 and 488 38th St.
Cable Address, ALEXCONNELL

WILLIAM H. DONOHUE

FLORAL DECORATOR

17 East 28th St., New York
Special Attention to Theatre
and Steamer Orders, and reliable
deliveries guaranteed.

DAVID CLARKE'S SONS

Deliver orders from any part of the country to
New York City

Or OUT-GOING STEAMERS

Write or telegraph

2139-2141 Broadway, New York
Telephone 1552-1553 Columbus

M. A. BOWE

In the Heart of New York City

1294 Broadway

Tel. 2270, 38th St. NEW YORK

Our Motto -- The Golden Rule.

YOUNG & NUGENT

42 West 28 St., NEW YORK

"FLOWERS BY TELEGRAPH"

Flower Deliveries

In Brooklyn and other Long Island Points
New York City, New Jersey, etc. At Theatres,
Hotels, Steamers or Residences.

WILSON

Fulton St. and Greene Ave., Brooklyn, N. Y.

ALBANY, N. Y.

EYRES

Flowers or Design Work

DELIVERED IN ALBANY AND VICINITY
ON TELEGRAPHIC ORDER.

11 NORTH PEARL ST., ALBANY, N. Y.

JACOB SCHULZ, 644 Fourth Ave.,
LOUISVILLE, KY.

Cut Flowers of BEST QUALITY in season
delivered promptly to any address.

Write, Telegraph or Telephone.
Cumberland and Home Phones 223 and 984

**PROMPT DELIVERY IN
BOSTON**

AND ALL NEW ENGLAND POINTS
HOUGHTON & CLARK
396 Boylston St., Boston, Mass.



BOSTON'S BEST
In Quality and Design

Can be relied upon when you transfer your retail orders to

EDWARD MACMULKIN
194 Boylston Street, Boston

Send flower orders for delivery in
BOSTON

and all
NEW ENGLAND POINTS
THOS. F. CALVIN
124 Tremont St., Boston

TRANSFER

Your orders for flower or plant delivery in Eastern New England to

JULIUS A. ZINN,
2 Beacon St., Boston.

Fine Design Work a Specialty

YALE

Orders for flower deliveries to Yale College and all other Connecticut

points carefully filled and delivered by

J. N. CHAMPION & COMPANY
1026 CHAPEL STREET NEW HAVEN, CONN.

Chicago. Established in 1857

**WITTBOLD
FLORIST**

1657-1659 Buckingham Place

L. O. Phone 558 Lake View. Send us your retail orders. We have the best facilities in the city.

**The Far-Famed Flowers of
TORONTO**

Delivered on mail or telegraph order for any occasion, in any part of the Dominion.

JOHN H. DUNLOP,
96 Yonge St., Toronto, Ont.

ATLANTA FLORAL CO.
41 Peachtree Street, ATLANTA, GEORGIA.

There are some
GOOD BARGAINS
listed in the
BUYERS' DIRECTORY,
Pages 640 to 644 this week.

HART'S HANDY HANDLE

"At Easter-time, with a little chiffon decoration, and the Handle, we were able to increase the value of plants from 50% to 100%."—H. E. WILSON.

Write for descriptive circular and prices

GEO. B. HART, 24 Stone St., Rochester, N. Y.

trade. Bulbous flowers range in the same category. Let our sales-people awake to the fact that variety creates appetite and that only through this appetite-creating system has the present high standing of our trade been achieved. Be original and go outside the line of carnations and roses and you will find the proper place for bulbous flowers where they are not only paying for themselves but also help to stimulate the sale of our home product.
FRANK DANZEL.

NEW RETAIL FLOWER STORES.

William Butler, Brunswick, Me.
A. H. Dailey, 511 Prince St., Knoxville, Tenn.
Mrs. Ennis, Caswell Building, Milwaukee, Wis.

NEWS NOTES.

A. Chandler Manning, landscape architect, has opened an office at Reading, Mass.

The name of the B. K. & B. Co. has been changed to the Charles Knopf Floral Co., Richmond, Ind.

Mrs. Tom Crawford opened the St. John greenhouses at Darien, Conn., in time to do a large Easter business.

Jos. P. Murray and Ira P. Hersey have acquired a place in Franklin, Mass., and have started in market gardening. They will also make a specialty of gladiolus bulbs and aster seed.

Edwin Lonsdale has a find in the shape of a dwarf form of Schizanthus Wisetonensis which has been thought worthy of a visit from the novelty committee of the Florists' Club of Philadelphia.

Jas. G. Hancock of La Grange, Ill., who is connected with Frank Oechslein's establishment, Chicago, lost his home and a large part of its contents by a fire which started from some unknown source in the early morning hours of May 5.

At a recent exhibition of the Royal Horticultural Society in London, Messrs. B. R. Cant & Co. exhibited a white sport from rose Dorothy Perkins, identical with that well-known variety except for the pure white flowers.

As announced in our advertising columns, A. Reper will disseminate his sensational carnation Bay State next season and is now booking orders. This carnation, which was the most noticed variety at the two last carnation conventions, is white with carmine markings in the way of Mrs. Patten; flower and stem very massive,

plant sturdy and free flowering. It is the progeny of two unnamed seedlings.

Detroit parks are all aglow with beautiful pansy beds. Some of the larger beds are planted with a dark blue variety bordered with a yellow variety. Beds of the old Primula auricula are also very effective, but we have to wait a few days for tulips, which only in the most favored positions show color.

The will of George W. Hammond of Yarmouth, Me., a copy of which has been filed in the Worcester county (Mass.) probate court, provides that after the death of his wife and sisters, from the principal of a trust fund there shall be paid to the president and fellows of Harvard College \$5000 for the use of the botanical garden and herbarium.

That the curtailment of business resulting from the money stringency last fall has not thus affected all industrial concerns is shown by the successful business of the American Nursery Company this spring, who report a material increase in orders over the combined business last year of the concerns now constituting the company, not only in wholesale trade all over the country but in furnishing private estates and public grounds, the latter exceeding all the anticipations formed earlier in the season from the general financial conditions.

INCORPORATED.

Northwest Nursery Co., Valley City, N. D.; E. A. Pray, E. C. Hilborn, P. A. Pickett, O. O. Wagley; capital, \$50,000.

Adam Pfeifer, father of Mrs. Fred Burki, of Gibsonsia, Pa., died on April 25 at the age of 88. Mr. Pfeifer was connected with the florist business in its early days.

BOSTON FLORIST LETTER CO.
Manufacturers of **FLORISTS' LETTERS**

This wooden box nicely stained and varnished, 18x30x12, made in two sections, one for each size letter, given away with first order of 500 letters

Block Letters, 1 1/2 or 2 inch size per 100, \$2.
Script Letters, 3. Fastener with each letter or word. Used by leading florists everywhere and for sale by all wholesale florists and supply dealers

N. F. MCCARTHY, Manager
66 Pearl Street, BOSTON, MASS.

NEW CROP
DAGGER FERNS
 \$2.00 per 1000
 Better Value than the old Stock

The Leo Niessen Company
 1209 Arch St., Philadelphia, Pa.
 Open from 7 a. m. to 8 p. m.

VALLEY
 Choicest, \$4.00 per hundred, \$30.00 per thousand
CEDAR BARK
 For covering window boxes, \$1.00 per bundle

S. S. PENNOCK - MEEHAN CO.
 1608-1620 Ludlow St. PHILADELPHIA
 "The" Wholesale Florists of Philadelphia

EVERYTHING SEASONABLE IN
CUT FLOWERS
 EDWARD REID, Wholesale Florist
 1526 Ranstead St., PHILADELPHIA
 STORE CLOSES 8 P. M.

CHAS. W. McKELLAR
 51 WABASH AVE., CHICAGO
 Western Headquarters for Choice Orchids
 Valley, Roses and all Cut Flowers

PETER REINBERG
 WHOLESALE
CUT FLOWERS
 51 Wabash Av., Chicago, Ill.

CUT FLOWER BOXES
 EDWARDS FOLDING BOX CO
 MANUFACTURERS
 PHILADELPHIA, PA.

AMERICAN BEAUTY and all other
ROSES
LILY OF THE VALLEY, CARNATIONS
WELCH BROS., 226 Devonshire St., Boston, Mass.

SWEET PEAS
 Never better than at present, good stem, good color, moderate price.

W. E. McKISSICK WHOLESALE FLORIST
 PHILADELPHIA
 1619-1621 RANSTEAD ST.

WHOLESALE FLOWER MARKETS—TRADE PRICES—Per 100 TO DEALERS ONLY

	CHICAGO May 5	TWIN CITIES May 4	PHILA. May 5	BOSTON May 6
ROSES				
Am Beauty, Fancy and Special...	25.00 to 30.00	35.00 to 40.00	20.00 to 25.00	15.00 to 20.00
" " Extra	15.00 to 20.00	25.00 to 35.00	15.00 to 18.00	12.00 to 15.00
" " No. 1	10.00 to 12.00	15.00 to 25.00	10.00 to 12.00	6.00 to 10.00
" " Lower grades	6.00 to 8.00	8.00 to 15.00	2.00 to 0.00	4.00 to 6.00
Bride, 'Maid, Fancy & Special	6.00 to 8.00	6.00 to 8.00	6.00 to 8.00	6.00 to 8.00
" " Extra and No. 1	3.00 to 4.00	3.00 to 5.00	3.00 to 5.00	3.00 to 5.00
" " Lower grades	1.00 to 2.00	1.00 to 3.00	1.00 to 2.00	1.00 to 2.00
Killarney, Richmond, Fan, & Sp.	6.00 to 8.00	7.00 to 12.00	13.00 to 15.00	8.00 to 10.00
" " Lower grades	2.00 to 4.00	4.00 to 7.00	3.00 to 8.00	2.00 to 6.00
Chatsway, Wellesley, Fan, & Sp.	6.00 to 8.00	5.00 to 8.00	4.00 to 6.00
" " Lower grades	2.00 to 4.00	3.00 to 5.00	1.00 to 3.00
Golden Gate, Ivory	2.00 to 6.00	2.00 to 8.00	1.00 to 6.00
CARNATIONS				
Fancy and Novelties	3.00 to 4.00	2.50 to 5.00	2.00 to 3.00	2.00 to 3.00
Ordinary	1.50 to 2.00	1.50 to 2.50	1.00 to50 to 1.00
MISCELLANEOUS				
Violets50 to 1.00 to to .35	.25 to .50
Cattleyas	50.00 to 75.00 to 50.00 to 75.00	50.00 to 60.00
Cypripediums to to to	8.00 to 10.00
Lilies	6.00 to 8.00	10.00 to 12.00 to 9.00	6.00 to 8.00
Lily of the Valley	3.00 to 4.00	3.00 to 4.00	2.00 to 4.00	1.00 to 3.00
Daisies50 to 1.00	.75 to 1.75	.50 to .75 to
Daffodils	1.00 to 2.00	2.00 to 3.00	1.00 to 2.00	.50 to 1.00
Tulips	1.00 to 2.00	2.00 to 3.00	2.00 to 3.00	.50 to 1.00
Mignonette	1.00 to 2.00	4.00 to 5.00	2.00 to 3.00	1.00 to 2.00
Gardenias	20.00 to 25.00	30.00 to 40.00 to 15.00	12.00 to 25.00
Lilac per bunch25 to .50	1.00 to 1.50 to 25.00	.50 to .75
Sweet Peas50 to 1.00	.60 to .75	.50 to .75	.25 to .50
Adiantum75 to 1.00	.75 to 1.00	1.00 to 1.50	1.00 to 1.50
Whitmanii Fronds to to	2.00 to 3.00	2.00 to 3.00
Smilax	12.00 to 15.00	12.00 to 15.00	15.00 to 20.00	10.00 to 12.00
Asparagus Plumosus, strings	35.00 to 50.00	35.00 to 50.00 to 5.00	25.00 to 50.00
" " & Soren. (100 bchs.)	25.00 to 35.00	35.00 to 50.00 to 50.00	15.00 to 50.00

DAILY CONSIGNMENTS
 From 40 to 60 Growers
 We can care for your cutflower wants to advantage.

E. F. WINTERSON CO.
 45-47-49 WABASH AVE., CHICAGO

Rice Brothers
 115 N. 6th Street, MINNEAPOLIS, MINN.
WHOLESALE FLORISTS and SUPPLIES
 CUT FLOWERS received twice daily, and can fill your orders to your satisfaction. A complete line of Hardy Greens - WILD SMILAX, BOXWOOD, HARDY FANCY FERNS, GALAX LEAVES.
 Write for quotations on large quantities.

H. BAYERSDORFER & CO.
 The Florists' Supply House of America
 Send for Illustrated Catalogue
 1129 ARCH ST., PHILA., PA.

Alex Mann, Jr. Co. Inc.
 Wholesale Dealer in
 Florists' Supplies and Cut Flowers
 White Doves, \$9.00 per doz.
 Galax Leaves.
 1125 Polk Street, San Francisco, Cal.

J. A. BUDLONG
 37-39 Randolph Street, CHICAGO.
 Roses and Carnations WHOLESALE CUT FLOWERS
 A Specialty..... GROWER of

Prices quoted in these columns are for Dealers Only. When writing to Advertisers Please Mention HORTICULTURE.

J. B. Murdoch & Co.
 Wholesale Florists
FLORISTS' SUPPLIES
 714 Penn Ave., PITTSBURG, PA.
 Long Distance Phone 1435 Court.

FLOWER MARKET REPORTS

BOSTON Complaint is general as to the flower trade here ever since Easter. At present it is exceedingly dull. In short, it is not a question of price but how to get rid of the product which, notwithstanding the cool weather, is coming to the wholesale markets in quantities undecreased. Violets linger but find no takers, even the street trade having no use for them. The street business has amounted to almost nothing this spring owing to the cutting off of all permission to sell on the public streets since about the first of this year. The fakir business can now be carried on only from stands on private property. The growers and wholesalers have always found this element a great help in unloading spring surpluses in former years and the present restrictions are a great handicap.

BUFFALO A few warm days brought on a heavy supply of all kinds of stock and up to Thursday of last week the coolers were much on the overstocked list, but always looking ahead for a clean-up on Friday and Saturday. The weather conditions were much against the flower buyers, as Thursday and Friday regular March weather was had with plenty of rain and snow; in fact, it could not have been worse for the trade, therefore the wholesaler carried all the stock. Nevertheless, on Saturday, a good clean-up was had, but roses moved rather slowly. The carnation quality has been good, but roses have not been up to the mark, excepting Richmonds, which have not been better this season and sell more readily than others. Lily of the valley, peas, snapdragon, outdoor tulips and daffodils, southern peonies and other stock were in good supply. Speculative buying was rather light, but considering the amount of stock accumulated during the week, the wholesaler must be satisfied with the clean-up which was had and prices obtained.

CHICAGO Prices for cut flowers are a little in advance of last week. Demand is light and the influx of southern flowers does not help matters. The prices on roses are approaching normal again, and quantities of really superior stock are seen in the wholesale market. The price of carnations has advanced more than that of any other flowers. Callas are hard to move and the demand for them seems to have lagged to a certain extent during the entire season. Gardenias are coming in rapidly from the south. The stock is very good and brings from one to two dollars, while forced gardenias sell for two or three dollars per dozen. Lilaes are also coming from the south. Taking it all around, the wholesale market has plenty of stock to offer but would like more buyers.

DETROIT No change in general business conditions. Cold weather intermingled with snowstorms did not help business either, but reduced the cut on carnations and roses. This week will see the end of bulbous flowers.

INDIANAPOLIS The reopening of the social season Easter Monday was less marked than is customary. The present warm weather means increased supplies with prices cut in half on almost everything. Bulb stock is gradually disappearing but still there is enough to meet the present demand. Beauties and teas are first class and prices reasonable. Carnations are probably the greatest drug on the market; nearly impossible to move them at any price. Sweet peas are abundant with demand about normal. Some peonies, gladioli and irises are on the market. Lilies seem to be hard to move.

NEW YORK Business continues to sag all through the wholesale and retail lines and prices have gone still lower during the past week. Outdoor lilacs from south and gardenias from further south are pouring in now, and the violets which have already gone, and arbutus which are waning, are not missed. Quality on all staples still holds good but with the supply so greatly in excess of the needs of the market quality is no great temptation.

PHILADELPHIA Last week found the market in a more demoralized condition, if it were possible, than any week this season so far. The warm weather brought stock out very plentifully indeed, not only greenhouse flowers, but a lot of outdoor blooms. The last of the week out-door lilac was very abundant; the better varieties of lilac not nearly so plentiful. A great many of the retailers are still using left-over plants and not buying as many cut flowers on this account. What cut lilies were left over from Easter were mostly dumped, an act much to be deplored. Roses and carnations sell at a very low figure indeed, carnations particularly. Sweet peas have fared if anything worse than roses or carnations. Taking the week as a whole, it has been very unsatisfactory indeed. What business was done was done with a great deal of effort and then the buyers were overcritical, which is generally the case when stock is plentiful. One of the bright spots was cattleyas; these were not very plentiful and sold well. Double violets are about done and the last few shipments have been coming in poor. Gardenias have been fairly plentiful, and the demand comparatively better than for any other flowers. Greens still move in fair shape.

TWIN CITIES The cut flower business for the last week has been fairly good. American Beauties are getting scarce; violets are about gone; carnations are plentiful, but bring a pretty good price.

WASHINGTON The midsummer of the latter part of April has been succeeded for the past week by cold, raw rain, and business is proportionately dull. Carnations have gone tumbling down in price and both they and sweet peas are a drag on the market. Outside lily of the valley of very fine quality is coming in in quantity and sells well. All outside flowers are suffering by the present inclement spell and it is to be hoped that the law of compensation will continue to hold good and that the demand for indoor grown things will improve.

Watch These Columns

for News of the
CUT FLOWER TRADE

If You Want
Flowers for

Memorial Day

You Will Find the Most
Reliable Dealers Always
Advertising in

Horticulture

Write to Them.

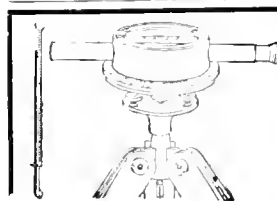

Bostrom Improved Builders' Levels and Farm Levels

For Park, Cemetery and Landscape Gardening use, take the place of expensive Engineering Instruments. Simple in construction, easily adjusted, more substantial and less cumbersome than the more elaborate and complicated instruments. Practical, up-to-date instrument that any one can use. Write for descriptive circulars and be convinced that this Level is necessary to complete your outfit. Builders' Level \$25.00. Farm Level \$12.50.

BOSTROM-BRADY MFG. CO., 139 Madison Avenue, ATLANTA, GA.

JOHN YOUNG
WHOLESALE FLORIST
 Finest American Beauties and Carnations
 51 West 28 St. - NEW YORK

FORD BROTHERS
 48 West 28th Street, NEW YORK
FINE ROSES FANCY CARNATIONS
 A Full Line of All CUT FLOWERS
 Telephone, 3870 or 3871 Madison Square

H. E. FROMENT,
 Wholesale Commission Florist,
 Choice Cut Flowers,
 57 West 28th St., :: NEW YORK.
 Telephones: 2200, 2201, Madison Square.

The Reliable Commission House
 Richmond Roses and Rich Flowers
 of all varieties
JOS. S. FENRICH
 110 W. 28th Street, New York
 Tel. 324-325 Madison Square

Alfred H. Langjahr
 All choice cut-flowers in season. Send
 for quotations. Correspondence with
 shippers of first-class stock invited.
 55 West 28th Street, New York.
 Telephones 4626-4627 Madison Square

JOHN I. RAYNOR
Wholesale Commission Florist SELLING AGENT FOR LARGEST GROWERS
 A full line of Choice Cut Flower stock for all purposes. Comprises every variety grown for New York market, at current prices
 TEL. 1998 MADISON SQUARE 49 W. 28 St., New York City

Walter F. Sheridan
 Wholesale Commission Dealer in
CHOICE CUT FLOWERS
 39 West 28th Street, New York
 Telephone: 3532-3533 Madison Square

HEADQUARTERS FOR NOVELTIES
ORCHIDS A SPECIALTY
 THE HIGHEST GRADE OF **VALLEY** ALWAYS ON HAND
 GARDENIAS, DAISIES, ROSES AND CARNATIONS
 Telephone
JAMES McMANUS, 759 Mad. Sq. 42 W. 28th St., New York

PHILIP F. KESSLER 55 & 57 W. 26th St., New York City
 Commission Dealer, Wholesale Buyer and Seller of
CUT FLOWERS
 Open from 5 a. m. to 6 p. m. Sunday till 10 a. m.
 Tel., 5243 and 2921 Madison Sq. Res., 345 J., Newtown.
Finest Lilies in the Market Every Day in the Year.

WHOLESALE COMMISSION FLORIST
J. K. ALLEN 106 W. 28 ST. NEW YORK
 Telephone 167 Madison Sq.
 OPEN 6 A.M. DAILY
 We have a good regular outlet for seasonable flowers

NEW YORK QUOTATIONS PER 100—TO DEALERS ONLY

	Last Half of Week ending May 2 1908	First Half of Week beginning May 4 1908		Last Half of Week ending May 2 1908	First Half of Week beginning May 4 1908
Roses					
Am. Beauty, lan and sp.	10.00 to 15.00	10.00 to 15.00	Cattleyas.....	25.00 to 40.00	25.00 to 40.00
" extra	6.00 to 8.00	6.00 to 8.00	Lilies	2.00 to 4.00	2.00 to 4.00
" No. 1	4.00 to 6.00	4.00 to 6.00	Lily of the Valley.....	1.00 to 3.00	1.00 to 3.00
" Lower grades50 to 2.00	.50 to 2.00	Daisies.....	.25 to 1.00	.25 to 1.00
Bride, 'Mald, lan and sp	3.00 to 5.00	3.00 to 5.00	Daffodils	1.00 to 1.50	1.00 to 1.50
" extra	1.00 to 3.00	1.00 to 3.00	Tulips.....	1.00 to 2.00	1.00 to 2.00
" lwr. grds.....	.50 to 1.00	.50 to 1.00	Mignonette.....	1.00 to 2.00	1.00 to 2.00
Killarney, Richmond, fancy & spec	3.00 to 8.00	3.00 to 8.00	Gardenias.....	10.00 to 25.00	10.00 to 25.00
" lower grades.....	1.00 to 3.00	1.00 to 3.00	Lilac per bunch.....	.20 to .25	.20 to .25
Chatenay, Wellesley, lan. and spec.....	3.00 to 5.00	3.00 to 5.00	Sweet Peas.....	.20 to .60	.20 to .60
" lower grades.....	.50 to 1.00	.50 to 1.00	Adiantum.....	.50 to .75	.50 to .75
Golden Gate, Ivory.....	.50 to 4.00	.50 to 4.00	Smilax.....	10.00 to 12.00	10.00 to 12.00
Carnations, Fancy and Novelties. ..	1.50 to 2.00	1.50 to 2.00	Asparagus Plumosae, strings.....	15.00 to 25.00	15.00 to 25.00
" Ordinary50 to 1.00	.50 to 1.00	" " & Spren. (100 bchs.)	15.00 to 25.00	15.00 to 25.00
Violets to to			

B. S. SLINN, Jr.
WHOLESALE FLORIST
 55 & 57 W. 26th St., New York City
 Tel., 3864 Madison Sq. Shipping Orders Solicited.
VIOLETS **Roses and Carnations**

Edward C. Horan
Wholesale Florist
 55 WEST 28th ST.
 Tel. 1462 Madison Square New York

TRAENDLY & SCHENCK
WHOLESALE FLORISTS
 Furnish best stock at fair prices all the year round Send for quotations on fall orders
 Tel. 798-799 Madleon Sq. 44 West 28th Street, New York City

Alexander J. Guttman
THE WHOLESALE FLORIST OF NEW YORK
 43 WEST 28th STREET
 PHONES. 1664-1665 MADISON SQUARE
ENOUGH SAID



HARDY CUT FERNS

Sphagnum Floss, Extra Large Bales, per bale, \$1.25. Fancy and Dagger Ferns our specialty. A trial order will convince you that we ship only first-class stock. Headquarters for Florists' supplies and wire work. All cut flowers in season. **BOXWOOD**, per bunch 35c, 50 lbs. \$7.50.

MICHIGAN CUT FLOWER EXCHANGE, INC.

All 'phone connections

38-40 Broadway, Detroit, Mich.

FANCY and DAGGER

Extra fine, \$1.75 per 1000. Bronze and Green Galax, \$1.25 per 1000. Leucothoe Sprays, \$1.00 per 100, \$7.50 per 1000.

Headquarters in Western New York

FOR

ROSES, CARNATIONS

And all kinds of Seasonable Flowers

Wm. F. Kasting Co.

Wholesale Commission Florist, also Dealer in Florists' Supplies and Wire Designs.

383-87 ELLICOTT ST.

BUFFALO, N. Y.

Give us a trial. We can please you.

FRANK S. HICKS & CO.

Wholesale Florists.

Open Now for Consignments of Cut Flowers.

39 West 28th Street, - New York City

Tel. 2920 Mad. Sq.

ROBERT J. DYSART,

Public Accountant and Auditor

Simple methods of correct accounting especially adapted for florists' use.

Books Balanced and Adjusted

Merchants Bank Building

28 STATE ST., - BOSTON

Telephone, Main 58

HENRY M. ROBINSON & CO.

Wholesale and Commission

FLORISTS

Hardy Cut Evergreens and Florists' Supplies

15 Province St. and 9 Chapman Place, BOSTON, MASS.

Flowers and Florists' Supplies

The best place in AMERICA to buy

BAY TREES

N. F. McCarthy & Co.

84 Hawley St., BOSTON, MASS.

Largest Dealers in Supplies in New England.

SAMUEL A. WOODROW

WHOLESALE PLANTSMAN

Palms, Large and Small Ferns, etc.

53 West 30th Street, NEW YORK

Telephone 2083 Madison

WILLIAM H. KUEBLER

Brooklyn's Foremost and Best

WHOLESALE COMMISSION HOUSE

A First Class Market for all CUT FLOWERS

28 Willoughby St., Brooklyn, N. Y.

Tel. 4591 Main

CLEARY'S HORTICULTURAL CO.

Management AMBROSE T. CLEARY

Wholesale Contracting, Jobbing, Auction

HORTICULTURAL PRODUCTS

of every description.

Consignments Received. Surplus Stock Converted.

62 Vesey St., NEW YORK

Moore, Hentz & Nash,

Wholesale Commission Florists,

55 and 57 West 26th Street,

Telephone No. 756
Madison Square.

New York.

WHOLESALE FLOWER MARKETS. — TO DEALERS ONLY.

	CINCINNATI April 27		DETROIT May 4		BUFFALO April 22		PITTSBURG May 4	
ROSES								
Am. Beauty, Fan. and Sp.....	20.00	to 25.00	20.00	to 25.00	30.00	to 35.00	20.00	to 25.00
“ Extra	12.00	to 15.00	12.00	to 15.00	20.00	to 30.00	to 15.00
“ No. 1	6.00	to 8.00	6.00	to 12.00	8.00	to 10.00	to 8.10
“ Lower grades.....	to 4.00	2.00	to 4.00	to 8.00	to 4.00
Bride, 'Maid, F. & S.....	to 8.00	6.00	to 8.00	8.00	to 10.00	to 8.00
“ Extra.....	4.00	to 6.00	4.00	to 6.00	6.00	to 6.00	to 6.00
“ Low gr.....	to 2.00	2.00	to 3.00	3.00	to 6.00	to 3.00
Killarney, Richmond, Fan. & Sp.....	to 8.00	6.00	to 8.00	8.00	to 10.00	to 10.00
“ Lower grades.....	to 6.00	2.00	to 3.00	3.00	to 8.00	to 6.00
Chatenay, Wellesley, Fan. & Sp.....	6.00	to 8.00	6.00	to 8.00	8.00	to 10.00	4.00	to 6.00
“ Lower grades.....	to 4.00	2.00	to 3.00	4.00	to 8.00	to 6.00
Golden Gate, Ivory.....	to 6.00	to 6.00	4.00	to 6.00	to 6.00
CARNATIONS								
Fancy and Novelties.....	to 2.00	2.00	to 3.00	2.00	to 3.00	to 2.00
Ordinary.....	1.00	to 1.50	1.00	to 2.00	1.50	to 2.00	1.00	to 1.50
MISCELLANEOUS								
Violets.....	to .50	.50	to .75	.50	to .75	to .50
Cattleyas.....	to 75.00	50.00	to 60.00	60.00	to 75.00	to 75.00
Cyripediums.....	to	to	to	to
Lilies.....	6.00	to 8.00	6.00	to 8.00	8.00	to 12.00	6.00	to 8.00
Lily of the Valley.....	2.00	to 4.00	2.00	to 3.00	2.00	to 4.00	3.00	to 4.00
Daisies.....	1.00	to 1.50	.50	to 1.00	1.00	to 2.00	1.00	to 1.50
Daffodils.....	1.00	to 2.00	to 3.00	2.00	to 3.00	1.00	to 2.00
Tulips.....	to 2.00	2.00	to 4.00	2.00	to 3.00	to
Mignopette.....	2.00	to 3.00	4.00	to 6.00	2.00	to 4.00	2.00	to 4.00
Gardenias.....	to	20.00	to 35.00	30.00	to 40.00	to
Lilac per bunch.....	1.50	to 2.00	1.00	to 1.50	1.50	to 2.00	to
Sweet Peas.....	.50	to .75	2.00	to 3.00	.40	to .75	.50	to .75
Adiantum.....	to 1.25	to 1.00	.50	to 1.00	to 1.25
Whitman's Fronds.....	to	to	8.00	to 10.00	to
Smilax.....	to 15.00	12.00	to 15.00	to 15.00	to 15.00
Asparagus Plumosus, strings.....	30.00	to 50.00	35.00	to 50.00	50.00	to 60.00	to 50.00
“ “ & Spren.(100 bchs.)	30.00	to 50.00	35.00	to 50.00	25.00	to 50.00	to 50.00

H. C. BERNING

Wholesale Florist

1402 Pine Street, ST. LOUIS, MO.

MILLANG BROS.

WHOLESALE COMMISSION FLORISTS

41 West 28th Street

Telephones 3860
61 Madison

NEW YORK

A. MOLTZ

Will purchase flowers on order in N. Y. market and ship carefully at prevailing wholesale prices. Address

155-57 West 26th Street, New York City

REED & KELLER

122 West 25th St., New York

Florists' Supplies

We manufacture all our

Metal Designs, Baskets, Wire Work & Novelties

and are dealers to

Glassware Decorative Greene and Florists' Requisites

In writing to Advertisers kindly mention Horticulture

Buyer's Directory and Ready Reference Guide

Advertisements under this head, one cent a word. Initials count as words.

Regular advertisers in this issue are also listed under this classification without charge. Reference to List of Advertisers will indicate the respective pages.

Buyers failing to find what they want in this list will confer a favor by writing us and we will try to put them in communication with reliable dealers.

ACCOUNTANT

R. J. Dysart, 28 State St., Boston.
For page see List of Advertisers.

ALTERNANTHERAS

Red Alternanthera at 40 cents per 100.
C. W. Moeckel, 17 Summer St., Fitchburg, Mass.

ANEMONES

Henry A. Dreer, 714 Chestnut St., Phila.

AQUATIC PLANTS

Aquarium plants the year round. Wholesale and retail. Send for price list.
Schmid's Emporium of Pets, 712 12th Street, Washington, D. C.

Water Lilies, Nymphaea Odorata Rosen, \$2.00 per doz. W. I. Bodfish, West Barnstable, Mass.

ASPARAGUS

A. N. Pierson, Cromwell, Conn.
Asparagus Plumosus Seedlings.
For page see List of Advertisers.

J. M. Thorburn & Co., 33 Barclay St., New York.

Plumosus Nanus and P. Robustus.
For page see List of Advertisers.

Asparagus plumosus and Sprengeri, 2-lb., strong, \$2.25 per 100. J. H. Dann & Son, Westfield, N. Y.

150 Asparagus plumosus nanus, 2½-in., extra fine, 3c.; 300 Pteris Ovarvardi, 2½-in., 2c.; heliotropes, 2-in., 2c.; dahlia roots, best varieties, \$2.00 per 100; mixed, \$1.50. Edwin Bishop, Roslyn, Md.

Asparagus Plumosa, 2 lb. pots. Fine plants, \$3.00 per 100; \$25.00 per 1000. Cash with order or good reference. Erie Floral Co., Erie, Pa.; or, Wm. F. Kasting Co., 385 Ellicott St., Buffalo, N. Y.

ASTER SEED

Altimo Culture Co., Canfield, O.
For page see List of Advertisers.

AUCTION SALES

Clary's Horticultural Co., 62 Vesey St., New York.

For page see List of Advertisers.

Wm. Elliott & Sons, 42 Vesey St., New York
For page see List of Advertisers.

AZALEAS

A. Leuthy & Co., Perkins St. Nurseries, Roslindale, Mass.

For page see List of Advertisers.

August Rolker & Sons, New York, 31 Barclay St., or P. O. Box 752.

For page see List of Advertisers.

BAMBOO CANES

Stumpp & Walter Co., 50 Barclay St., New York.

For page see List of Advertisers.

Yokohama Nursery Co., 31 Barclay Street, New York.

For page see List of Advertisers.

BAY TREES.

N. F. McCarthy & Co., 84 Hawley St., Boston.

For page see List of Advertisers.

Bay Trees and Box Trees, standards and pyramids. All sizes. Price list on application. J. Roehrs Co., Rutherford, N. J.

BEDDING PLANTS

R. Vincent, Jr., & Sons Co., White Marsh, Maryland.

For page see List of Advertisers.

A. N. Pierson, Cromwell, Conn.
For page see List of Advertisers.

40,000 geraniums, 10 best standard sorts; 5000 Vinca variegata; Salvia; heliotrope, dark; feverfew, double white. Good stock, prices right. E. D. Kaulback & Son, Malden, Mass.

BEGONIAS

Thomas Roland, Nahant, Mass.

Gloire De Lorraine.

For page see List of Advertisers.

10,000 Begonia Vernon, 2 in., 2c. M. Fenton, West Newton, Pa.

Begonia "Agatha" (Veitch) (Improvement on Beg. Gloire de Lorraine) an easier grower, earlier flowering and of a more pleasing shade of soft, satiny pink; strong young plants from leaf cuttings, now ready; \$18.00 per 100.

Begonia "Gloire de Lorraine", strong, young plants from leaf cuttings, ready for delivery early in June; \$15.00 per 100; \$100.00 per 1000.

J. A. Peterson,

McHenry Ave., Westwood, Cincinnati, O.

BERBERIS THUNBERGII

Oak Hill Nurseries, Roslindale, Mass.

For page see List of Advertisers.

BOILERS

BOILERS. "Barnham" Boilers made for greenhouse heating. Lord & Barnham, 1133 Broadway, N. Y.

BUILDERS' AND FARM LEVELS

Bostrom-Brady Mfg. Co., 139 Madison Ave., Atlanta, Ga.

For page see List of Advertisers.

BUILDING MATERIAL

BUILDING MATERIAL of all description for All Cypress, Semi-Iron, Iron Frame or Truss Houses. Hot Bed Sash and Frames. Lord & Barnham Co., 1133 Broadway, N. Y.

BULBS AND TUBERS

Joseph Breck & Sons, 47-54 N. Market St., Boston.

For page see List of Advertisers.

J. M. Thorburn & Co., 33 Barclay St., New York.

For page see List of Advertisers.

A. T. Boddington, 342 W. 14th St., N. Y.
For page see List of Advertisers.

Rickards Procs., 37 East 19th St., New York.
For page see List of Advertisers.

H. F. Mitchell Co., Philadelphia.

For page see List of Advertisers.

H. E. Fliske Seed Co., Faneull Hall Sq., Boston.

For page see List of Advertisers.

James Vlek's Sons, Rochester, N. Y.

Fall Bulbs.

For page see List of Advertisers.

Aug. Rolker & Sons, 31 Barclay St., New York.

Seasonable Import Plants and Bulbs.

For page see List of Advertisers.

K. Veitbays, Hillegom, Holland,
Represented by Felix Bosch, 260 Clarendon St., Boston.

Bulbs French and Dutch.

For page see List of Advertisers.

Ralph M. Ward & Co., 2 W. Broadway, New York, Agts. for Martial Bremond, Orlhoues, France.

French Bulbs.

For page see List of Advertisers.

W. J. Eldering & Son, Overveen, Haarlem, Holland.

High Grade Dutch Bulbs.

For page see List of Advertisers.

A. Mitting, 17-23 Kennan St., Santa Cruz, California.

California Bulbs.

For page see List of Advertisers.

Stumpp & Walter Co., 50 Barclay St., N. Y.

Canna Bulbs.

CANNAS

The Conard & Jones Co., West Grove, Pa.

For page see List of Advertisers.

J. B. Shurtleff & Son, Cushman Ave.,

Revere, Mass.

Live Cannas Started from Sand.

For page see List of Advertisers.

Stumpp & Walter Co., 50 Barclay St.,

New York.

CAPE JASMINE BUDS

Chas. Ehlers, Houston, Texas.

For page see List of Advertisers.

CARNATIONS

F. Dorner & Sons Co., Lafayette, Ind.

For page see List of Advertisers.

S. S. Skidelaky, 1741 N. 18th St., Philadelphia.

For page see List of Advertisers.

Chicago Carnation Co., Joliet, Ill.

For page see List of Advertisers.

John E. Haines, Bethlehem, Pa.

Carnations Imperial and Pink Imperial.

For page see List of Advertisers.

Chas. H. Totty, Madison, N. J.

A. N. Pierson, Cromwell, Conn.

For page see List of Advertisers.

H. F. Littlefield, 552 Main St.,

Worcester, Mass.

For page see List of Advertisers.

White Enchantress, unrooted cutting. Write for prices. Won first prize for best vase of 50. F. H. Westhoff, De Haven, Pa.

Carnation cuttings of all the leading varieties at the same price as any reliable firm. Write for prices before you look elsewhere. Wm. F. Kasting Co., 385 Ellicott St., Buffalo, N. Y.

CARNATIONS! FIELD GROWN!!

15,000 Enchantress and Winsor, ready for delivery July 1st. Orders filled in strict rotation. Order now and be first! Prices on application. We guarantee satisfaction. We lead in superb field grown stock.

WANOKA GREENHOUSES,
Barneveld, N. Y.

Columbia Carnation Co., New London, Ct.
For page see List of Advertisers.

CAULIFLOWER AND CABBAGE SEED

H. Hartmann & Co., Copenhagen, Denmark.

For page see List of Advertisers.

CHRYSANTEMUMS

Chas. H. Totty, Madison, N. J.
Single Chrysanthemums.

For page see List of Advertisers.

A. N. Pierson, Cromwell, Conn.
For page see List of Advertisers.

Wm. W. Edgar Co., Waverley, Mass.
For page see List of Advertisers.

H. F. Littlefield, 552 Main St., Worcester, Mass.

For page see List of Advertisers.

H. L. Cameron, No. Cambridge, Mass.
For page see List of Advertisers.

Chrysanthemum rooted cuttings, best varieties; write for list and prices. Edwin Bishop, Roslyn, Md.

Chrysanthemums. 5000 unrooted cuttings of Yellow Bonnaillon, 70c. per 100. F. H. Westhoff, De Haven, Pa.

Chrysanthemums—Christmas, Polly Rose, Pacific, Hallday, Nonin and others, \$1.25 per 100. F. P. Sawyer, 125 High St., Clinton, Mass.

For List of Advertisers See Page 645

CHRYSANTHEMUMS — Continued

Have 100,000 fine young well-rooted 'Mums, cuttings of the best 60 commercial varieties. Send for our new and low price list. Satisfaction guaranteed. Wm. Ehmman, Jr., Corfu, N. Y.

Chrysanthemums ready: 2 1-2 inch strong stock of Touselet, Oct. Frost, Polly Rose, Wanamaker, and all standard, \$3 per 100, \$25 per M. New: 2 1-2, strong, Alice Rosevelt, Hankey, Clay Frick, Winter Cheer, Roaette, B. May, \$5 per 100, \$40 per M. Cash. Send for catalog. Harlowarden Greenhouses, Greenport, N. Y.

Chrysanthemums. Pine, strong, 2 and 2 1-2 in. pot plants of Mourvina, October Frost, Rosiere, Touselet, Alice Byron, Dr. Enguehard, \$3.00 per 100; \$25.00 per 1000. Cash or C. O. D. Gunnar Teilmann, Marion, Ind.

COLEUS

A. N. Pierson, Cromwell, Conn.
For page see List of Advertisers.

Coleus, Golden Bedder, Verschaffelt, and mixed Coleus, rooted cuttings, 60c. per 100; \$5.00 per 1000. Cash with order. J. E. Felthousen, Florist, Schenectady, N. Y.

Coleus cuttings, 60c. 100; 2 in., 2c. mixed. M. Fenton, West Newton, Pa.

CONIFERS

John Waterer & Sons, Ltd., American Nursery, Bagshot, Eng.
For page see List of Advertisers.

CUT FLOWER BOXES.

Edwards Folding Box Co., Philadelphia.
For page see List of Advertisers.

Folding cut flower boxes, the best made. Write for list. Holton & Hunkel Co., Milwaukee, Wis.

DAHLIAS

David Herbert & Son, Atco, N. J.
For page see List of Advertisers.

R. Vincent, Jr. & Sons Co., White Marsh, Maryland.

For page see List of Advertisers.

Dahlia Bulbs, 25 choice named varieties, 1-3 Cactus, for \$1. Catalog free. C. Peirce, Dighton, Mass.

Dahlias, balance of season, 25 named varieties, postpaid, \$1.00. Catalogue free. J. L. Moore, Northboro, Mass.

Dahlias: About 2000 Cath. Duer, Kreimhilde, Brunnhilde, Snowlad, etc., \$3 per 100. Cash. Harlowarden Greenhouses, Greenport, N. Y.

Dahlias. Novelty and standard varieties, true to name, a choice list of the best introductions. Send for catalogue of dahlias, hollyhocks, hardy plants, etc. W. W. Wilmore, Box 382, Denver, Colo.

Dahlia Roots—Undivided field clumps. Lyndhurst, Maid of Kent, William Agnew, White Swan, Kreimhilde, John Walker, Arabella and A. D. Livoni. Write for low prices. Wood & Healey, Hammonton, New Jersey.

Cactus, Decorative, Show, Fancy and Pompon Dahlias. 75 leading varieties to select from. Strong divided clumps, in 10 or 20 varieties, my selection at \$3.00 per 100; \$25.00 per 1000. Single Dahlias, mixed, \$1.00 per 100. Cash with order please. Hermann Thiemann, Mouson, Mass.

DECORATIVE PLANTS

A. Leuthy & Co., Perkins St. Nurseries, Roslindale, Mass.
For page see List of Advertisers.

DRACAENAS

Dracena indivisa, 5-in., perfect plants, 30 to 36 inches high, \$2.50 per doz.; 2 1/2-in., strong seedlings, \$2.00 per 100. Jos. Labo, Joliet, Ill.

ECHEVERIAS

Echeverias, \$18 per 1000, post paid. McDowell, Mexico City.

FERNS

A. Leuthy & Co., Roslindale, Mass.
For page see List of Advertisers.

H. H. Barrows & Son, Whitman, Mass Nephrolepis Whitman.
For page see List of Advertisers.

John Scott, Brooklyn, N. Y.
For page see List of Advertisers.

FERTILIZERS

Pulverised Manure Co., 31 Union Stock Yards, Chicago, Ill.
Wizard Brand Cattle Manure.
For page see List of Advertisers.

Thos. J. Grey & Co.,
\$2 and \$3 South Market St., Boston.
High-Grade Scotch Soot.
For page see List of Advertisers.

FLORAL PHOTOGRAPHS

Floral Photographs. Foley's 226-228 1-2 Bowery, New York.

FLORISTS' LETTERS.

Boston Florist Letter Co., 66 Pearl St., Boston, Mass.
For page see List of Advertisers.

Koral Mfg. Co., 26 Hawley St., Boston.
For page see List of Advertisers.

FLORISTS SUPPLIES

N. F. McCarthy & Co., 84 Hawley St., Boston.

For page see List of Advertisers.

H. M. Robinson & Co., 15 Province St. and 9 Chapman Pl., Boston, Mass.
For page see List of Advertisers.

Reed & Keller, 122 W. 25th St., New York.
For page see List of Advertisers.

J. B. Murdoch & Co., 714 Penn Ave., Pittsburg, Pa.

For page see List of Advertisers.

H. Bayersdorfer & Co., 1129 Arch St., Philadelphia.

For page see List of Advertisers.

Alex. Mann, Jr., Co., 1125 Polk St., San Francisco, Calif.

For page see List of Advertisers.

FLOWERS BY TELEGRAPH

Park Floral Co., Denver, Colo.
For page see List of Advertisers.

J. N. Champlon & Co., 1026 Chapel St., New Haven, Conn.

For page see List of Advertisers.

George H. Cooke, Washington, D. C.
For page see List of Advertisers.

Gude Bros. Co., 1214 F St., Washington, D. C.

For page see List of Advertisers.

Atlanta Floral Co., Atlanta, Ga.
For page see List of Advertisers.

M. C. & J. E. Hauawirth, 232 Michigan Ave., Chicago.

For page see List of Advertisers.

William J. Smyth, Michigan Ave. and 31st St., Chicago.

For page see List of Advertisers.

George Wittbold Co., 1657-59 Buckingham Place, Chicago.

For page see List of Advertisers.

Jacob Schulz, 644 4th Ave., Louisville, Ky.
For page see List of Advertisers.

Thos. F. Galvin, 124 Tremont St., Boston.
For page see List of Advertisers.

Julius A. Zinn, 2 Beacon St., Boston.
For page see List of Advertisers.

Houghton & Clark, 396 Boylston St., Boston.

For page see List of Advertisers.

Sidney Hoffman, 59-61 Massachusetts Ave., Boston.

For page see List of Advertisers.

Edward MacMullin, 194 Boylston St., Boston.

For page see List of Advertisers.

J. Breitmeyer's Sons, Miami and Gratiot Aves., Detroit, Mich.

For page see List of Advertisers.

Samuel Murray, 1017 Broadway, Kansas City, Mo.

For page see List of Advertisers.

Wm. L. Rock Flower Co., 1116 Walnut St., Kansas City, Mo.

For page see List of Advertisers.

Fred C. Weber, 4326-28 Olive St., St. Louis, Mo.

For page see List of Advertisers.

H. G. Eyrea, 11 N. Pearl St., Albany, N.Y.
For page see List of Advertisers.

David Clarke's Sons, 2139-2141 Broadway, New York.

For page see List of Advertisers.

W. H. Donohoe, 17 E. 28th St., New York.
For page see List of Advertisers.

Alex. McConnell, New York.

For page see List of Advertisers.

FLOWERS BY TELEGRAPH — Continued

M. A. Bowe, 1294 Broadway, New York.
For page see List of Advertisers.

Robert G. Wilson, Fulton St. & Greene Av., Brooklyn, N. Y.
For page see List of Advertisers.

Thomas Young, Jr., 500 Fifth Ave., N. Y.
For page see List of Advertisers.

Young & Nugent, 42 W. 28th St., N. Y.
For page see List of Advertisers.

J. H. Dunlop, 96 Yonge St., Toronto, Can.
For page see List of Advertisers.

FLOWER POTS

W. H. Ernest, 23th and M Sta., Washington, D. C.
For page see List of Advertisers.

A. H. Hews & Co., Cambridge, Mass.
For page see List of Advertisers.

Hillinger Bros., Ft. Edward, N. Y.
For page see List of Advertisers.

Red pots, seed pans, etc.
The Peters & Reed Pottery Co., Zanesville, O.

FORESTRY AND ORNAMENTAL PLANTING

Jackson's Nurseries, Portland, Me.
For page see List of Advertisers.

FOR-GET-ME-NOTS

Warren Shinn, Woodstown, N. J.

GALAX

Michigan Cut Flower Co., 38 and 40 Broadway, Detroit, Mich.
For page see List of Advertisers.

GARDEN VASES

Kramer Bros. Foundry Co., Dayton, O.
For page see List of Advertisers.

GERANIUMS

R. Vincent Jr. & Sons Co., White Marsh, Md.

New and Standard Varieties.
For page see List of Advertisers.

Wm. W. Edgar Co., Waverley, Mass.
For page see List of Advertisers.

Geraniums, 2-in., double red, \$1.50 per 100. J. H. Dann & Son, Westfield, N. Y.

H. L. Cameron, No. Cambridge, Mass.
For page see List of Advertisers.

I have a lot of good 4-in. Geraniums in the following varieties about 20,000 in all: Nutt, La Pilot, Flora Hill, Buchner, Mme. Sallerei and a few others at from \$7.00 to \$10.00 per 100. Also Alternantheras, mostly red, at \$2.00 per 100; Coleus at \$2.50 per 100; and a few other varieties in plants. Hermann Schoenfeld, 86th and Crothers Ave., Elmwood, Philadelphia, Pa.

GLADIOLI

I. & J. L. Leonard, Iona, N. J.
Gladiolus Bulbs.

Gladioli. Write for booklet. B. Hammond Tracy, Cedar Acres, Weuham, Mass.

Gladiolus, large flowering mixed, balance of season, \$1.00 per 100; postpaid. J. L. Moore, Northboro, Mass.

Gladiolus Bulbs and hard hybridized seed. Newest. Best. Circular free. B. F. White, Terryville, Conn.

Gladioli, choice mixed, 65c. per 100. W. I. Bodfish, West Barnstable, Mass.

GLASS

Boston Plate & Window Glass Co., Boston.
For page see List of Advertisers.

Standard Plate Glass Co., 26-30 Sudbury St., Boston.

For page see List of Advertisers.

S. Jacobs & Sons, 1365-79 Flushing Ave., Brooklyn, N. Y.

Metropolitan Material Co., 1398-1408 Metropolitan Ave., Brooklyn, N. Y.
For page see List of Advertisers.

Foley Mfg. Co., Western Ave., between 25th & 26th Sts., Chicago.

Greenhouse glass, lowest prices. Johnston Glass Co., Hartford City, Ind.

GLASS, High Grade, Double Thick Greenhouse Glass. Lord & Barnham, 1138 Broadway, N. Y.

In writing to Advertisers kindly mention Horticulture

GLAZING POINT

H. A. Dreer, Philadelphia, Pa.
For page see List of Advertisers.

GLAZING POINTS, Lord & Burnham
Special Glazlog Nalls (Points), Lord &
Burnham, 1133 Broadway, N. Y.

GREENHOUSE BUILDING MATERIAL

Lord & Burnham Co.,
1133 Broadway, New York.
For page see List of Advertisers.
Pierson U-Bar Co., 1 Madison Sq., N. Y.
For page see List of Advertisers.

A. T. Stearns Lumber Co., Neponset,
Boston.
For page see List of Advertisers.
King Construction Co., N. Tonawanda,
New York.
For page see List of Advertisers.

J. C. Moninger Co., 117 East Blackhawk St.,
Chicago, Ill.
For page see List of Advertisers.

Foley Mfg. Co., Western Ave., between
25th & 26th Sts., Chicago.
For page see List of Advertisers.

I. Cassidy, Summer Ave. and Erie R. R.,
Newark, N. J.
For page see List of Advertisers.

Geo. B. Doane, 18 Midway St., Boston.
Iron Pipe.
B. Jacobs & Sons, 1365-79 Flushing Ave.,
Brooklyn, N. Y.
Metropolitan Material Co., 1398-1408 Metro-
politan Ave., Brooklyn, N. Y.
For page see List of Advertisers.

GREENHOUSE CONSTRUCTION
GREENHOUSE CONSTRUCTION, Semi-
Iron Greenhouse, New Truss Houses and
Iron Frame Houses. Lord & Burnham,
1133 Broadway, N. Y.

J. A. Payne, 260-274 Culver Ave., Jersey
City, N. J.
For page see List of Advertisers.

I. Cassidy, Summer Ave. and Erie R. R.,
Newark, N. J.
For page see List of Advertisers.

Foley Mfg. Co., Western Ave., between
25th & 26th Sts., Chicago.
For page see List of Advertisers.

GUTTERS

GUTTERS, Cast Iron Gutters, L. & B.
Improved V Shaped Gutter with drip gutter
attachment. Lord & Burnham, 1133
Broadway, N. Y.

HAIL INSURANCE

Florists' Hall Asso. of America.
J. G. Esler, Saddle River, N. J.
For page see List of Advertisers.

HARDY FERNS AND SUPPLIES
H. M. Robinson & Co., 13 Province St.
and 9 Chapman Pl., Boston, Mass.
For page see List of Advertisers.

Michigan Cut Flower Exchange,
88 and 40 Broadway, Detroit, Mich.
Fancy Ferns.
For page see List of Advertisers.

HARDY PERENNIALS

The Storrs & Harrison Co., Painesville, O.

HART'S HANDY HANDLE
Geo. B. Hart, 24 Stone St., Rochester, N. Y.
For page see List of Advertisers.

HEATING APPARATUS

Lord & Burnham Co.,
1133 Broadway, New York.
For page see List of Advertisers.
Pierson U-Bar Co., 1 Madison Sq., N. Y.
For page see List of Advertisers.

John A. Payne, 260-274 Culver Ave., Jersey
City, N. J.
For page see List of Advertisers.

HEDGE PLANTS

Peter's Nursery, Knoxville, Tenn.
For page see List of Advertisers.

HELIOTROPES.

Heliotropes, 2-in., 2c.; rooted cuttings,
from soil, 75c. per 100. Edwin Bishop,
Roslyn, Md.

HELP FURNISHED

Thos. H. Rambrick, 34 S. 7th St., Phila.
For page see List of Advertisers.

HERBACEOUS PERENNIALS

Red Oak Nurseries, Plskeville, K. I.
Bay State Nurseries, No. Abington, Mass.
For page see List of Advertisers.

New England Nurseries, Inc.,
Bedford, Mass.
For page see List of Advertisers.
P. Ouwerkerk, P. O. No. 2, Hoboken, N. J.
For page see List of Advertisers.

HOLLYHOCKS

Hollyhocks, separate colors, field grown,
healthy stock, \$3.00 per 100; also Dahlias,
novelties and standard varieties. Send for
catalogue. W. W. Wilmore, Box 382, Den-
ver, Colo.

HOT-BED SASH

The A. T. Stearns Lumber Co., Neponset,
Mass.

For page see List of Advertisers.
Pierson U-Bar Co., 1 Madison Sq., N. Y.
For page see List of Advertisers.

Lord & Burnham Co., 1133 Broadway, N. Y.
For page see List of Advertisers.

Foley Mfg. Co., Western Ave., between
25th & 26th Sts., Chicago.

HYDRANGEAS.

HYDRANGEAS PANICULATA.
Grandiflora, 18-in. to 24-in., \$5.00 per 100.
Grandiflora, 2 ft. to 3 ft., \$7.00 per 100.
Grandiflora, 3 ft., \$8.00 per 100.
J. H. Dann & Son, Westfield, N. Y.

W. W. Edgar Co., Waverley, Mass.
For page see List of Advertisers.

INSECTICIDES.

Nicotelle kills all greenhouse pests.
P. R. Palethorpe Co.,
Eleventh St., Owensboro, Ky.
For page see List of Advertisers.

IRISES

J. M. Thorburn & Co., 33 Barclay St.,
New York.
For page see List of Advertisers.

Henry A. Dreer, 714 Chestnut St., Phila.
Japan Iris (Iris Kaempferi), divided roots,
2-5 shoots, mixed, \$4.00 per 100; divided
roots, 2-5 shoots, white, \$5.00 per 100.
Large clumps, 10c. each. Wm. F. Halsey,
Southampton, N. Y.

JAPANESE PLANTS

Yokohama Nursery Co., 31 Barclay St.,
New York.
For page see List of Advertisers.

JUMPING BEANS

Jumping Beans, \$5 per 1000, post paid.
McDowell, Mexico City.

KENTIAS

A. Leathy & Co., Roselindale, Mass.
For page see List of Advertisers.

LAWN VASES

Kramer Bros. Fdy. Co., Dayton, Ohio.
For page see List of Advertisers.

LILIES

W. W. Edgar Co., Waverley, Mass.
For page see List of Advertisers.

LOBELIAS

Lobelia Crystal Palace compacta, strong,
bushy plants, 2-in., \$2.00 per 100. N. E. Beck,
Massillon, O.

Double Lobelia, Kathleen Mallard, 3 in.,
Sep.; 2-1.4 in., full of buds and bloom;
strong cuttings from soil, 2c. Mme. Sal-
ford geraniums, 2-1.2 in., 2-1.2c. Reduced
prices; 1 need room. J. L. Stone, Tru-
mansburg, N. Y.

MASTICA

F. O. Pierce Co., 12 W. Broadway,
New York.
For page see List of Advertisers.

MOON VINES

Godfrey Aschmann, 1012 W. Ontario St.,
Philadelphia.
For page see List of Advertisers.

Moon vines, fine strong plants, 3 in.,
\$4.00 per 100. Edwin Bishop, Roslyn, Md.

MYRTLE

Myrtle for cemetery planting, strong
field grown clumps, \$2.00 per 100, or \$17.50
per 1000. Geo. A. Dhanan, East Walnut
Hills, Cincinnati, O.

NEW AND RARE PLANTS

Rose Hill Nurseries, New Rochelle, N. Y.
For page see List of Advertisers.

NICO-FUME

Kentucky Tobacco Product Co.,
Louisville, Ky.
For page see List of Advertisers.

NURSERY STOCK

John Waterer & Sons, Ltd.,
American Nursery, Bagshot, England.
For page see List of Advertisers.
New England Nurseries, Bedford, Mass.
Shrubs, Roses and Herbaceous Perennials.
Specimen Pyramidal Box.
For page see List of Advertisers.

Bay State Nurseries, N. Abington, Mass.
Herbaceous Perennials, Hardy Ornamental
Trees.
For page see List of Advertisers.

Cleary's Horticultural Co., 62 Vesey St.,
New York.
For page see List of Advertisers.

P. Ouwerkerk, 216 Jane St., Weehawken
Heights, N. J.
Holland Nursery Stock for Forcing.
For page see List of Advertisers.

American Nursery Co., 150 Broadway, New
York, N. Y.
For page see List of Advertisers.

I. & J. L. Leonard, Iona, N. J.
California Privet, American Chestnuts.
Peter's Nursery Co., Knoxville, Tenn.
Live Fences; Amoor and California Privet.
For page see List of Advertisers.

Jackson's Nurseries, Portland, Me.
For page see List of Advertisers.

ORCHID PLANTS

Lager & Hurrell, Summit, N. J.
For page see List of Advertisers.

Sander, St. Albans, England.
Importers, Exporters, Growers, Hybridists
For page see List of Advertisers.

Julius Roehrs Co., Rutherford, N. J.
For page see List of Advertisers.

Carrillo & Baldwin, Secaucus, N. J.
For page see List of Advertisers.

Joe. A. Manda, 191 Valley Road, W.
Orange, N. J.
For page see List of Advertisers.

Ordonez Bros., Madison, N. J., Box 106.
For page see List of Advertisers.

PALMS

A. Leathy & Co., Perkins St. Nurseries,
Roselindale, Mass.
For page see List of Advertisers.

Robert Craig Co., Market and 49th Sts.,
Philadelphia, Pa.
For page see List of Advertisers.

August Rolker & Sons, 31 Barclay St.,
New York.
For page see List of Advertisers.

Kentia, Phoenix, etc., all sizes. Write
for new price list. Julius Roehrs Co.,
Rutherford, N. J.

Komitsch & Junge, Secaucus, N. J.

PAINT AND PUTTY

PAINT AND PUTTY: Ideal Greenhouse
lead; Special Greenhouse Putty. Lord &
Burnham, 1133 Broadway, N. Y.

PANSY PLANTS.

Pansies, a mixture of the finest strains
of exhibition stock obtainable in Germany
and America. Seed bought direct from the
growers. Good, strong, frame-grown plants,
75c. per 100; \$6.00 per 1000. N. E. Beck,
Massillon, O.

100,000 extra fine giant pansies, good,
stocky, transplanted plants in bud and
bloom, \$1.00 per 100; \$8.00 per 1000. Cash
with order. M. A. Hough, Pansy Special-
ist, Milan, O.

PATENTS

Siggers & Siggers, Washington, D. C.
For page see List of Advertisers.

PEAT

Orchid peat, Rotted peat, Azalea peat,
Leaf-Mould, Live Sphagnum moss, Baled
Jobbers' list on application. C. W. Brown-
Sphagnum moss, Green Clump moss, etc.
ell & Co., Walden, N. Y.

PELAGONIUMS

R. Vincent, Jr. & Sons Co., White Marsh,
Maryland.
For page see List of Advertisers.

For List of Advertisers See Page 645

PEONIES

Wholesale Peony list for fall 1908 is now ready. J. F. Rosenfield, West Point, Neb.
 One of the finest collections in America. Send 25 cts. in stamps for new edition of Peony Manual. C. S. Harrison's Select Nursery, York, Neb.

PHLOXES

Henry A. Dreer, 714 Chestnut St., Phila.
 Send 25 cts. in stamps for Phlox Manual. Fine mixed phloxes \$1.50 per 100. C. S. Harrison's Select Nursery, York, Neb.

PIPE AND FITTINGS

Foley Mfg. Co., between Western Ave. and 26th St., Chicago, Ill.
 Eagle Metal & Supply Co., Johnson and Union Aves., Brooklyn, N. Y.
 Second-Hand Pipe and Boiler Tubes.

PIPE AND FITTINGS. Cast Iron and Wrought Pipe, Valves, Elbows, Pipe Hooks, Automatic Air Headers, etc. Lord & Burnham, 1133 Broadway, N. Y.

PLANT STAKES AND TRELLISES

Seele's Patent, for roses, chrysanthemums, gladioli, tuberoses, dahlias, tomatoes, egg plants, etc. H. D. Seele & Sons, Manuf., Elkhart, Ind.

PLANT TUBS

Keystone Cedar Plant Tubs.
 Henry A. Dreer, 714 Chestnut St., Phila.

POT HANGERS

Pot hangers, Kramer's \$1 doz. by exp., \$1.25 by mail. I. N. Kramer & Son, Cedar Rapids, Ia.

PRIMULAS

Primula obconica, famous Rousdorf & Lattmann strains. Large flowering blue, blood red, 40c. 1-2; 75c. tr. pkt. Carmine, lilac, dark eyed, rose, white, mixed, fringed lilac, white, mixed, 30c. 1-2, 50c. tr. pkt. P. Obs. Gigantea, originator's strain; Lilac, rose, mixed, 40c. 1-2, 75c. tr. pkt. Carmine, 40c. red, 25c. pkt. Primula Chinensis, from the best specialist. Fringed blue, double mixed, 60c. 1-2, \$1.00 tr. pkt. Blood red, carmine, marbled, rose, striped, white, mixed, 40c. 1-2, 75c. tr. pkt. J. L. Schiller, 929 Prouty Av., Toledo, O.

PRIMULA SEED

H. E. Fiske Seed Co., 13 Faneuil Hall Sq., Boston.
 For page see List of Advertisers.
 O. V. Zangen, Hoboken, N. J.
 For page see List of Advertisers.

RAFFIA

Raffia (colored), 20 beautiful shades. Samples free. R. H. Comey Co., Camden, N. J.; 810 Washburn Ave., Chicago, Ill.

RETAIL FLORISTS

Park Floral Co., Denver, Colo.
 For page see List of Advertisers.
 George H. Cooke, Washington, D. C.
 For page see List of Advertisers.
 Gude Bros. Co., 1214 F St., Washington, D. C.
 For page see List of Advertisers.
 Atlanta Floral Co., Atlanta, Ga.
 For page see List of Advertisers.
 M. C. & J. E. Hauswirth, 232 Michigan Ave., Chicago.
 For page see List of Advertisers.
 William J. Smyth, Michigan Ave. and 81st St., Chicago.
 For page see List of Advertisers.
 George Wittbold Co., 1657-59 Buckingham Place, Chicago.
 For page see List of Advertisers.
 Jacob Scholz, 644 4th Ave., Louisville, Ky.
 For page see List of Advertisers.
 Thos. F. Galvin, 124 Tremont St., Boston.
 For page see List of Advertisers.
 Julia A. Zinn, 2 Beacon St., Boston.
 For page see List of Advertisers.
 Houghton & Clark, 396 Boylston St., Boston.
 For page see List of Advertisers.
 Sidney Hoffman, 59-61 Massachusetts Ave., Boston.
 For page see List of Advertisers.
 Edward MacMulkin, 194 Boylston St., Boston.
 For page see List of Advertisers.

RETAIL FLORISTS - Continued

J. Breitmeyer's Sons, Detroit, Mich.
 For page see List of Advertisers.
 Samuel Murray, 1017 Broadway, Kansas City, Mo.
 For page see List of Advertisers.
 Wm. L. Rock Flower Co., 1116 Walnut St., Kansas City, Mo.
 For page see List of Advertisers.
 Fred C. Weber, 4326 Olive St., St. Louis, Mo.
 For page see List of Advertisers.
 J. N. Champion & Co., 1028 Chapel St., New Haven, Conn.
 For page see List of Advertisers.
 H. G. Eyres, 11 N. Pearl St., Albany, N. Y.
 For page see List of Advertisers.
 David Clarke's Sons, 2139-2141 Broadway, New York.
 For page see List of Advertisers.
 W. H. Donohoe, 17 E. 28th St., New York.
 For page see List of Advertisers.
 Alex. McConnell, New York.
 For page see List of Advertisers.
 M. A. Bowe, 1294 Broadway, New York.
 For page see List of Advertisers.
 Robert G. Wilson, Fulton St. and Greene Ave., Brooklyn, N. Y.
 For page see List of Advertisers.
 Thomas Young, Jr., 500 Fifth Ave., N. Y.
 For page see List of Advertisers.
 Young & Nugent, 42 W. 28th St., N. Y.
 For page see List of Advertisers.
 J. H. Dunlop, 96 Yonge St., Toronto, Can.
 For page see List of Advertisers.

RHODODENDRONS

John Waterer & Sons, Ltd., American Nursery, Bagshot, England.
 For page see List of Advertisers.
 P. Ouwerkerk, Hoboken, N. J.
 For page see List of Advertisers.
 New England Nurseries, Bedford, Mass.
 For page see List of Advertisers.
 Eastern Nurseries, Jamaica Plain, Mass.
 Hardy Hybrid and Dwarf Rhododendrons.
 For page see List of Advertisers.

ROSES

Julius Roebis Co., Rutherford, N. J.
 Rambler Rose, Newport Fairy.
 For page see List of Advertisers.
 New England Nurseries, Inc., Bedford, Mass.
 For page see List of Advertisers.
 Bay State Nurseries, N. Abington, Mass.
 For page see List of Advertisers.
 Robert Craig Co., Market and 49th Sts., Philadelphia, Pa.
 For page see List of Advertisers.
 Dingee-Conard Co., West Grove, Pa.
 For page see List of Advertisers.
 F. R. Pierson Co., Tarrytown-on-Hudson, N. Y.
 Hardy Rosea for the Garden.
 For page see List of Advertisers.
 R. & J. Farquhar & Co., 6 and 7 South Market Street, Boston.
 For page see List of Advertisers.
 The E. G. Hill Co., Richmond, Ind.
 Roses, Rhes Reid, American Beauty.
 For page see List of Advertisers.
 Poehlmann Bros. Co., Morton Grove, Ill.
 Mrs. Potter Palmer, Cardinal, Beauty.
 For page see List of Advertisers.
 P. Ouwerkerk, P. O. No. 2, Hoboken, N. J.
 For page see List of Advertisers.
 Chas. H. Totty, Madison, N. J.
 400 varieties; own roots; summer grown. Leedle Company, Springfield, Ohio.
 Crimson Ramblers, 2 year, on own roots, extra strong, at 7 cents. Gilbert Costich, Rochester, N. Y.
 Low-budded roses, No. 1, \$95.00; No. 11-2, \$65.00 1000. H. T. Jones, Elizabeth, N. J.

S. A. F. CONVENTION ACCOMMODATIONS

Tower Hotel, Niagara Falls, N. Y.
 For page see List of Advertisers.

SALVIAS

Salvia splendens, extra strong, 2-in. plants, \$2.00 per 100; \$20.00 per 1000. This is elegant stock, large and strong enough for 4-in. pots. N. E. Beck, Massillon, O.
 Colhanzie Carnation Co., New London, Ct.
 Salvia Splendens.
 For page see List of Advertisers.

SEEDS

T. J. Grey Co., 32 So. Market St., Boston, Mass.
 For page see List of Advertisers.
 Joseph Breck & Sons, 51 and 52 N. Market St., Boston, Mass.
 For page see List of Advertisers.
 W. Atlee Burpee & Co., Philadelphia.
 For page see List of Advertisers.
 J. M. Thorburn & Co., 33 Barclay St., N. Y.
 For page see List of Advertisers.
 A. T. Boddington, 342 W. 14th St., N. Y.
 For page see List of Advertisers.
 H. F. Mitchell Co., 1017 Market St., Phila.
 For page see List of Advertisers.
 James Vick's Sons, Rochester, N. Y.
 Vick's Superb Pansy Seed.
 For page see List of Advertisers.
 Hjalmar Hartmann & Co., 12 Stormgade, Copenhagen, Denmark.
 Cauliflower and Cabbage Seed.
 For page see List of Advertisers.
 Rickards Bros., 37 E. 19th St., New York.
 For page see List of Advertisers.
 R. & J. Farquhar & Co., 6-7 So. Market St., Boston.
 For page see List of Advertisers.
 C. C. Morae & Co., 48-56 Jackson St., San Francisco, Cal.
 For page see List of Advertisers.
 H. E. Fiske Seed Co., Faneuil Hall Sq., Boston.
 Primula Fringed Sinensis.
 For page see List of Advertisers.
 Brasian Seed Growers Co., San Jose Cal.
 For page see List of Advertisers.
 O. V. Zangen, Hoboken, N. J.
 For page see List of Advertisers.
 Stumpp & Walter Co., 50 Barclay St., New York.
 W. F. Allen, Salisbury, Md.
 For page see List of Advertisers.

Asparagus Pl. Nanns, \$2.50 per 1000. Plant early. Asparagus Plants 14 to 18 inches high, \$5.00 per 100. Peter Mack, Box 172, Orlando, Fla.

Davis Perfect and Burrell's Klondike Cucumber Seed, 85c. per pound. Finest slicing varieties grown. D. V. Burrell, Rocky Ford, Colorado.

SHEEP MANURE

Henry A. Dreer, 714 Chestnut St., Philadelphia.

SMILAX

Smilax, choice young plants from fall; \$3.00 per 1000, 2000 for \$5.00, 5000 for \$10.00; 50c. per 100 by mail. F. A. Baller, Bloomington, Ill.

SPHAGNUM MOSS

Live Sphagnum moss, orchid peat and orchid baskets always on hand. Lager & Hurrell, Summit, N. J.
 Fresh, clean, 5 bbl. bale, \$1.25; 2 bales, \$2.25; 5 bales, \$5.00; 10 bales, \$9.50. Comb. H. R. Akers, Chatsworth, N. J.

SPIREA

W. W. Edgar Co., Waverley, Mass.
 For page see List of Advertisers.

SPRAYERS

Charles J. Jager Co., 281-85 Franklin St., Boston.
 For page see List of Advertisers.
 "Showermaker," \$1. Jos. Kopcsay, So. Bend, Ind.

STRAWBERRY PLANTS

C. S. Pratt, Reading, Mass.
 The Dicky.
 Strawberry plants and Asparagus roots (50 varieties). Catalog free. C. Peirce, Dighton, Mass.

STEAM TRAP

E. Hppard, Youngstown, O

In writing to Advertisers kindly mention Horticulture

TRITOMAS

Henry A. Dreer, 714 Chestnut St., Phila.

TO-BAK-INE

E. H. Hunt, Genl. Agt., 76-78 Wabash Av., Chicago.
For page see List of Advertisers.

VEGETABLE PLANTS

It. Vincent, Jr. & Sons Co., White Marsh, Maryland.
For page see List of Advertisers.

VENTILATING APPARATUS

Pearson U-Bar Co., 1 Madison Sq., N. Y.
For page see List of Advertisers.
Foley Mfg. Co., Western Ave., between 25th & 26th Sts., Chicago.
For page see List of Advertisers.
John A. Payne, 230-274 Culver Ave., Jersey City, N. J.
For page see List of Advertisers.
The Advance Co., Richmond, Ind.
For page see List of Advertisers.
Quaker City Machine Co., Richmond, Ind.
20th Century Ventilating Arm.
For page see List of Advertisers.

VENTILATING MACHINERY, New Model enclosed, self-oiling gear; Standard Model Open Gear. Lord & Burnham, 1133 Broadway, N. Y.

VERBENAS

Mammoth verbenas, strong, 2 in. plants from seed, in red, white, pink, purple and striped shades, separate or mixed, \$2.00 per 100; \$20.00 per 1000. N. E. Beck, Massillon, O.

VIOLETS

William Sim, Cliftondale, Mass.
Violet Boston.
For page see List of Advertisers.
Violet cuttings, "Marla Louisa" Rhinebeck stock, rooted runners, May delivery \$20.00 M. Wm. F. Kasting Co., 383 Ellcott St., Buffalo, N. Y.

WIREWORK

Reed & Keller, 122 W. 25th St., N. Y.
For page see List of Advertisers.
Wirework. Write for our catalogue. Holton & Hunkel Co., Milwaukee, Wis.
William E. Hellscher's Wire Works, 38-40 Broadway, Detroit, Mich.
Headquarters for wire work. Send for list. Ball & Betz, 31 E. 3rd St., Cincinnati, O.

WHOLESALE FLORISTS

Boston

N. F. McCarthy & Co., 84 Hawley St., Boston.
For page see List of Advertisers.
H. M. Robinson & Co., 15 Province St. and 9 Chapman Pl., Boston.
For page see List of Advertisers.
Welch Bros., 226 Devonshire St., Boston.
For page see List of Advertisers.

Buffalo

Wm. F. Kasting Co., 383-87 Ellcott St., Buffalo, N. Y.
For page see List of Advertisers.

Chicago

Chas. W. McKellar, 51 Wabash Ave., Chicago.
For page see List of Advertisers.
Peter Reinberg, 51 Wabash Ave., Chicago.
For page see List of Advertisers.
E. F. Wlaterson Co., 45-49 Wabash Ave., Chicago.
For page see List of Advertisers.
J. A. Budlong, 37-39 Randolph St., Chicago.
For page see List of Advertisers.

Detroit

Michigan Cut Flower Exchange, 38 and 40 Broadway, Detroit, Mich.
For page see List of Advertisers.

Minneapolis

Rice Bros., 115 N. 6th St., Minneapolis, Minn.
For page see List of Advertisers.

New York

J. K. Allen, 106 W. 28th St., New York
For page see List of Advertisers.
J. S. Fenrich, 110 W. 28th St., New York.
For page see List of Advertisers.

WHOLESALE FLORISTS—

New York—Continued

Ford Bros., 48 W. 28th St., New York
For page see List of Advertisers.
H. E. Froment, 57 W. 28th St., New York.
For page see List of Advertisers.
Alex. J. Guttman, 43 W. 28th St., New York.
For page see List of Advertisers.
E. C. Horan, 55 W. 28th St., New York
For page see List of Advertisers.
A. H. Langjahr, 55 W. 28th St., New York.
For page see List of Advertisers.
James McManus, 42 W. 28th St., New York
For page see List of Advertisers.
John I. Raynor, 49 W. 28th St., New York.
For page see List of Advertisers.
W. F. Sheridan, 39 W. 28th St., New York
For page see List of Advertisers.
Traendly & Schenck, 44 W. 28th St., New York.
For page see List of Advertisers.
John Young, 51 W. 28th St., New York.
For page see List of Advertisers.
Moore, Hentz & Nash, 55 and 57 W. 26th St., New York.
For page see List of Advertisers.
Frank S. Hicks & Co., 39 W. 28th St., New York.
For page see List of Advertisers.
Wm. H. Kuebler, 28 Willoughby St., Brooklyn, N. Y.
For page see List of Advertisers.
Phillip F. Kessler, 55 and 57 W. 26th St., New York.
For page see List of Advertisers.
A. Moltz, 55-57 W. 26th St., New York.
For page see List of Advertisers.
B. S. Shun, Jr., 55 W. 26th St., New York.
For page see List of Advertisers.
Millang Bros., 41 W. 28th St., New York.
For page see List of Advertisers.

Philadelphia

W. E. McKissick, 1619-1621 Ranstead St., Philadelphia, Pa.
For page see List of Advertisers.
Leo Niessen Co., 1209 Arch St., Philadelphia, Pa.
For page see List of Advertisers.
The S. S. Pennock-Meehan Co., 1608-18 Ludlow St., Philadelphia, Pa.
For page see List of Advertisers.
Edward Reid, 1523 Ranstead St., Philadelphia, Pa.
For page see List of Advertisers.

Pittsburg

J. B. Murdoch & Co., 714 Penn Ave., Pittsburg, Pa.
For page see List of Advertisers.

San Francisco

Alex. Mann, Jr., Co., 1125 Polk St., San Francisco, Cal.
For page see List of Advertisers.

St. Louis

H. G. Bernlog, 1402 Pine St., St. Louis, Mo.
For page see List of Advertisers.

WHOLESALE PLANTSMAN

Samuel A. Woodrow, 53 W. 80th St., New York.
For page see List of Advertisers.

WILD SMILAX

E. A. Beaven, Evergreen, Ala.
Southern Wild Smilax: Log Mosses.
For page see List of Advertisers.

New Offers in This Issue.

ARAUCARIAS, PALMS, BEDDING PLANTS.

A. Lenthly & Co., Perkins St. Nurseries, Roslindale, Mass.
For page see List of Advertisers.

CARNATION BAY STATE.

Albert Roper, Tewksbury, Mass.
For page see List of Advertisers.

CHINESE PRIMROSE, CINERARIA, GIANT PANSY SEEDS.

John F. Rupp, Shiremanstown, Pa.
For page see List of Advertisers.

CHRYSANTHEMUMS, SPECIAL OFFER.

Chas. H. Totty, Madison, N. J.
For page see List of Advertisers.

COLD STORAGE LILIES.

A. T. Boddington, 342 W. 14th St., New York.
For page see List of Advertisers.

ELECTRIC CIRCULATOR.

The Castle Co., 170 Summer St., Boston.
For page see List of Advertisers.

GRANDIFLORA CAPE JESSAMINE BUDS.

C. W. Benson, Alvin, Texas.
For page see List of Advertisers.

HARDY CLIMBERS.

Henry A. Dreer, 714 Chestnut St., Phila.
For page see List of Advertisers.

HOT WATER BOILERS.

Kroeschell Bros. Co., 35 Erie St., Chicago.
For page see List of Advertisers.

NEW CROP FERNS FOR DECORATION DAY.

E. A. Beaven, Evergreen, Ala.
For page see List of Advertisers.

ORCHIDS JUST ARRIVED.

Carrillo & Baldwin, Secaucus, N. J.
For page see List of Advertisers.

PANSIES.

I. E. Coburn, 291 Ferry St., Everett, Mass.
For page see List of Advertisers.

ROSES.

Dingee-Conard Co., West Grove, Pa.
For page see List of Advertisers.

ROSES: KILLARNEY, RICHMOND, BRIDESMAIDS.

P. R. Quinlan, Syracuse, N. Y.
For page see List of Advertisers.

RUBBERS, ARAUCARIAS, BEDDING PLANTS.

John McKenzie, North Cambridge, Mass.
For page see List of Advertisers.

SPRING FLOWERING BULBS.

Henry F. Michell Co., Phila.
For page see List of Advertisers.

TUBEROSES.

Stump & Waller Co., 50 Barclay St., New York.
For page see List of Advertisers.

SPECIAL SURPLUS LIST

These prices holding good only until present surplus is reduced).

	Per 100	Per 100	
Begonia Rex, fine collection of varieties,	\$3.00	Baby Rambler Rose	\$2.00
Begonia Thurstoni and P. Daw	2.50	Clothilde Souper Rose	2.50
Fuchsias, strong stock, 8 varieties	2.50	Salvia Splendens	2.50
Violet, Prince of Wales	2.50	Ivy Geraniums	2.50
Verbenas, all colors	2.50	Dracena Indivisa	2.50
Pandanus Urtis, 2 1/2 in.	4.00	Pelargoniums, 3 in.	10.00
Pandanus Urtis 4 in.	8.00	Digitalis, two colors, field grown	4.00
Kaiserin Roses, Fresh propagation	3.00	Campanula, in variety, field grown	4.00
		Shasta Daisies, in variety, field grown	3.00

THE STORRS & HARRISON CO., Painesville, Ohio

List of Advertisers

	Page
Advance, The Co.	647
Allen J. K.	638
Allen W. F.	631
Altimo Culture Co.	631
American Nursery	628
American Nursery Co.	629
Aschmann G.	618
Atlanta Floral Co.	635
Bambrick Thos. H.	645
Barrows H. H. & Son	620
Bayersdorfer H. & Co.	636
Bay State Nurseries	629
Beaven E. A.	627
Benson C. W. & Co.	627
Berning H. G.	639
Boddington A. T.	627
Boston Florist Letter Co.	635
Boston Plate and Window Glass Co.	646
Bosch, Felix	618
Bostrom-Brody Mfg. Co.	637
Bowe, M. A.	634
Braslan Seed Growers Co.	631
Breck Joseph & Sons	631
Breitmeyer's J. Sons	633
Bremond Martial	633
Bridgeman's Seed Warehouse	631
Budlong J. A.	636
Burpee W. A. & Co.	631
Cameron H. L.	619
Carrillo & Baldwin	620
Cassidy I.	647
Castle Co.	646
Champion J. N. & Co.	635
Chicago Carnation Co.	618
Clarke's David, Sons	624
Clary's Horticultural Co.	639
Coburn I. E.	627
Cohanzie Carnation Greenhouses	619
Conard & Jones Co.	618
Cooke G. H.	634
Craig, Rohrt, Co.	633
Dana W. J.	645
Dingee & Conard Co.	629
Doane Geo. B. & Son	647
Donohoe W. H.	634
Dorner F. Sons & Co.	619
Dreer H. A.	619
Dunlop John H.	635
Dysart R. J.	639
Eastern Nurseries	628
Edgar, W. W. Co.	633
Edwards Folding Box Co.	636
Ehlers	618
Eldering W. J. & Son	633
Elliott Wm. & Sons	627
Esler J. G.	647
Ernest W. H.	646
Eyres	634
Farguhar R. & J. & Co.	629
Fenrich J. S.	638
Fiske, H. E. Seed Co.	631
Foley Mfg. Co.	647
Ford Bros.	628
Froment H. E.	63
Galvin Thos. F.	635
Grey T. J. Co.	631
Gude Bros. Co.	634
Guttman Alex. J.	638
Haerens A.	631
Hall Asso.	647
Haines, J. E.	619
Hart, Geo. B.	635
Hartmann Hjalmar & Co.	631
Hauswirth M. C. & J. E.	634
Herbert David & Son	633
Hews A. H. & Co.	646
Hicks Frank S. & Co.	639
Hilfinger Bros.	646
Hill, The E. G. Co.	629
Hippard F.	647
Hoenig M. J.	627
Hoffman	635
Horan E. C.	638
Houghton & Clark	635
Huot E. H.	632
Jackson Nurseries	629
Jager, Chas. J. Co.	532
Kasting W. F.	639
Kentucky Tobacco Product Co.	632
Kessler, P. F.	638
King Cons. Co.	647
Kramer Bros. Fdy. Co.	633
Kroeschell Bras. Co.	646
Kuebler Wm. H.	639
Lager & Hurrell	620
Langjahr, Alfred H.	638
Leuthy A. & Co.	618
Lord & Burnham Co.	648
Littlefield H. F.	619
Manda Jos. A.	620
Mann, Alex. Jr. Co.	616
MacMulkin E. A.	635
McCarthy N. F. & Co.	639
McConnell Alex.	634
McKellar Charles W.	636
McKenzie John	627
McKissick, W. E.	636
McManus Jas.	638
Metropolitan Material Co.	647
Michell H. F. Co.	632
Michigan Cut Flower Exchange	639
Millang Bros.	639
Mitting, A.	618
Moltz, A. J.	634
Moninger J. C.	647
Moore, Hentz & Nash	639
Morse C. C. & Co.	631
Murdoch J. B. & Co.	636
Murray Samuel	634
New England Nurseries	628
Niessen Leo. Co.	636
Oak Hill Nurseries	628
Ordonez Bros.	620
Ouwerkerk P.	628
Paethorpe P. R. Co.	645
Park Floral Co.	634
Payne John A.	647
Pennock-Mechan Co.	636
Perkins St. Nurseries	618
Peter's Nursery Co.	629
Pierce F. O. Co.	646
Pierson, A. N.	619
Pierson F. R. Co.	629
Pierson U. Bar Co.	648
Pechlmann Bros. Co.	629
Pratt C. S.	630
Pulverized Manure Co.	634
Quaker City Machine Co.	647
Quinlan P. R.	633
Rawson W. W. & Co.	632
Raynor John I.	638
Reed & Keller	619
Reid Edw.	636
Reinberg Peter	636
Rice Bros.	616
Rickards Bros.	631
Robinson H. M. & Co.	639
Rock Wm. L. Flo. Co.	634
Rohrs Julius Co.	620
Rohr Albert	619
Roland, Thomas	618
Rolker August & Sons	633
Rose Hill Nurseries	646
Rupp J. F.	631
Sander & Son	620
Schulz Jacob	634
Scott, John	620
Sheridan W. F.	618
Shurtleff J. B. & Son	618
Siggers & Siggers	645
Sim Wm.	619
Situations & Wants	645
Skidelsky S. S.	619
Slina B. S. Jr.	638
Smyth Wm. J.	634
Standard Plate Glass Co.	645
Stearns A. T. Co.	647
Storrs & Harrison	644
Stumpp & Walter Co.	618
Thorburn J. M. & Co.	631
Totty Chas. H.	619
Tower Hotel	627
Traendly & Schenck	638
Valentine, J. A.	634
Velthuys K.	618
Vick's Jas. Sons	631
Vincent R. Jr. & Sons	630
Ward R. M. & Co.	633
Waterer John & Sons	628
Weathered Co.	648
Weber F. C.	634
Welch Bros.	616
Wilson	634
Winterson, E. F. Co.	636
Witthold Geo. Co.	635
Woodrow, Sam'l A.	639
Yokohama Nursery Co.	618
Young John	638
Young, Thos. Jr.	634
Young & Nugent	634
Zangen O. V.	631
Zinn J. A.	635

STANDARD PLATE GLASS CO.

Manufacturers—Importers—Jobbers

NOW IS THE TIME TO BUY

FRENCH OR AMERICAN GREENHOUSE GLASS

LOWEST PRICES ON REQUEST

26-30 Sudbury St.

BOSTON, MASS.

61-63 Portland St.

A PROSPEROUS BOILER MANUFACTURING CONCERN.

Kroeschell Bros. Co. of Chicago have at their works some forty odd hot-water greenhouse boilers all completed ready for shipment, all of which have been ordered and sold. Orders are coming in very rapidly and Mr. Kroeschell says it is barely possible that they may be quite busy at the end of the season, and therefore urges prospective buyers to place their orders at once; in which case they are very glad to build the boiler and hold it until such time when it is wanted, and do not ask for any payment until boiler is delivered.

Mr. Kroeschell states that the prospects are very good for this year's business, and if present sales are a criterion the sales this year will be fully double what they were last year. He finds that for greenhouse purposes the hot-water system of heating is becoming more and more popular not only for small ranges but also in the very largest ranges in the country. It would well repay any florist visiting Chicago to call at these works, and even though he may be no buyer or prospective buyer of a boiler, he will always find courteous treatment at the hands of Mr. Kroeschell.

GREENHOUSES BUILDING OR CONTEMPLATED.

- Monongahela, Pa.—I. S. Crall, one house.
- Lewiston, Me.—Ernest Saunders, additions.
- Calgary, Alta.—A. Terrill, range of houses.
- Phillipsburg, Pa.—George Parker, additions.
- Nampa, Ida.—A. H. Behrman, range of houses.
- N. Beverly, Mass.—Arthur Kidder, one house.
- Post Falls, Ida.—Wollan & McKay, range of houses.
- Fitzgerald, Ga.—Joel Thomas, addition and office building.
- Fall River, Mass.—Joseph H. Smith, house 12x20; shed, 7x10.

PATENTS

Trademarks and Copyrights

Send your business direct to Washington. Saves time and insures better service. Personal attention guaranteed. Twenty-five years' active service. SPECIALTY: "Working on the Failure of Others."

SIGGERS & SIGGERS

PATENT LAWYERS

Box 9, National Union Building
Washington, D. C.

WANTS, FOR SALE, ETC.

Advertisements in this column one cent a word. Initials count as words. Cash with order. All correspondence addressed "care HORTICULTURE" should be sent to 11 Hamilton Place, Boston.

HELP WANTED

FOREMAN WANTED

A man with good experience in Roses and Carnations to take charge of a commercial establishment growing for the wholesale trade.

W. J. DANA

Wellesley Hills, Massachusetts

HORTICULTURE needs a wide-awake representative in every town in the land. Good commission paid on advertising and subscriptions. If you are ambitious, write for terms.

WANTED—An all-round handy man, experienced in outdoor gardening, familiar with trees and shrubs; horse and cow to look after; good pay and when needed extra help; cottage and vegetables. Must be sober and faithful. Address C. C., care Horticulture, 11 Hamilton Place, Boston.

SITUATIONS WANTED

GOOD MEN

When you need good men, skilled or unskilled, Write:

THOS. H. BAMBRICK

34 South 7th Street Philadelphia

Help of all kinds, including that for Florists, Nurserymen, Seedsmen and the Horticultural trade generally.

SITUATION WANTED in general greenhouse work; single, age 35, five years' experience, commercial. Address W. W., care HORTICULTURE.

FOR SALE

FOR SALE—A large consignment of 16x24 double thick American glass, A and B quality. For further information write Parskelsky Brothers, 59 Montrose Avenue, Brooklyn, N. Y.

HARDWOOD ASHES FOR SALE—We have about three tons best quality hardwood ashes. Best offer takes it. Everett Sawdust Co., 16 Adams Ave., Everett, Mass.

In ordering goods please add "I saw it in HORTICULTURE."

IS YOUR NAME IN THE ABOVE LIST? IF NOT, WHY NOT?

KROESCHELL BROS. COMPANY,

35 ERIE STREET,
CHICAGO, ILL.

THE KROESCHELL BOILER CAN BE SEEN IN USE IN EVERY STATE IN THE UNION, BECAUSE
IT IS THE ONLY PERFECT HOT WATER BOILER

NOT CAST-IRON

Has Water in Front, Sides, Top and
a Water Back. Thin Water Ways.
Heats Quickly.

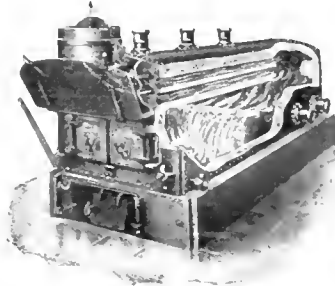

NO. 1 FOR SMALL GREENHOUSES

15 Sizes
Very
Powerful

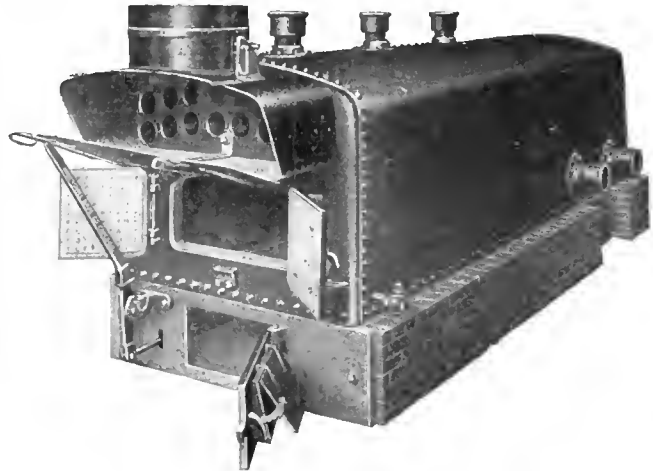

NO. 15 FOR 50,000 SQUARE FEET GLASS

Catalogue and prices on application.

THE ONLY BOILER THAT GOES DIRECT FROM THE MANUFACTURER TO THE USER

We have no agency commissions to pay and the consumer gets the benefit. Our customers boom our Boilers and with their help we sold during the season of 1906-7 Boilers to heat 4,286,500 SQUARE FEET OF GLASS, which is equivalent to 1,382 houses 27 x 100.

Figure It Out

Have you found out that lower values on your product makes it necessary that you figure close on every operation of your greenhouse?

TO WIN OUT TODAY

you must have the greatest amount of efficiency at the lowest amount of expense. No device has ever been offered that will do this for you so surely and effectually as

The Electric Circulator

Send us your address and we will send you some interesting facts and figures.

The Castle Company, Heating Engineers,

170 Summer Street,
Boston, Mass.

MASTICA
FOR Greenhouse Glazing
USE IT NOW.
F. O. PIERCE CO.
12 W. Broadway and
227 Greenwich St.
NEW YORK

BOSTON PLATE & WINDOW GLASS CO.
GREENHOUSE GLASS
German and American

261 to 287 A St., Boston 20-22 Canal St.



STANDARD FLOWER POTS

Packed in small crates, easy to handle.

Price per crate		Price per crate	
1500 2 1/2	\$4.88	120 7 lb. pots	\$4.20
1500 3 1/4	5.25	60 8 "	3.00
1500 2 3/8	6.00	HAND MADE	
1000 3	5.00	48 9 in. pots	\$3.60
800 3 3/8	5.80	48 10 "	4.80
500 4	4.50	24 11 "	3.60
320 5	4.50	24 12 "	4.80
144 6	3.16	12 14 "	4.80
		6 16 "	4.50

Seed pans, same price as pots. Send for price list of Cylinders for Cut flowers, Hanging Baskets, Lawn Vases, etc. Ten per cent. off for cash with order. Address Hilfinger Bros., Pottery, Fort Edward, N. Y. August Rolker & Sons, Agts., 31 Barclay St., N. Y. City.

Standard Flower . . POTS

If your greenhouses are within 500 miles of the Capitol, write us, we can save you money

W. H. ERNEST

28th and M Street WASHINGTON D. C.

JOHN A. PAYNE

Greenhouse Designer and Builder

260-274 Culver Ave., Jersey City



THE PAYNE

Galvanized Iron non-freezing Z Bar Eaves Plate is acknowledged to be the best and the most durable. No inside drip, no

sockets to hold moisture around wood bars.

Iron and wood frame greenhouses of every type—material only or erected.

LET US ESTIMATE.

The Advance Ventilating Apparatus

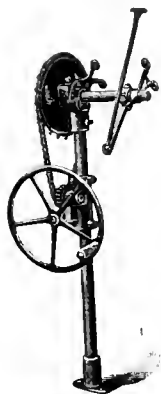

If our line did not have great merit we would not have been able to have our machines at work in 38 states in four years' time, to sell 3 machines to a florist because his neighbor bought one month ago, to sell 7 machines to another after using 8 last year, to sell 4 to another who bought 5 last August, to sell 12 to another, all in one week. Get our prices and estimates and give us a trial.

The Advance Co.
RICHMOND, IND.



DREER'S Florist Specialties.

New Brand New Style. Hose "RIVERTON" Furnished in lengths up to 500 ft. without seam or joint.

The HOSE for the FLORIST
 1/2-inch, per ft., 15 c.
 Keel of 500 ft., " 14 1/2 c.
 2 Reels, 1000 ft., " 14 c.
 1/2-inch, " 13 c.
 Reels, 500 ft., " 12 1/2 c.
 Couplings furnished.
HENRY A. DREER,
 714 Chestnut St.,
 PHILADELPHIA, PA.

I. CASSIDY

Designer and Builder of

Iron and Wood Greenhouses

Factory: Summer Ave and Erie R. R.

Newark, N. J.

R. TONAWANDA, N. Y.



KING CONSTRUCTION CO.
 GREENHOUSE CONSTRUCTION AND EQUIPMENT

WRITE FOR CATALOGUE AND PRICES

THE FOLEY MFG. CO.

CHICAGO

Completely equipped with up-to-date machinery for the making of material for

GREENHOUSE CONSTRUCTION

From a Full Supply of Thoroughly Seasoned Lumber

Send your sketches to our draughtsmen for completion and suggestion. Permit us to figure your proposed work, large or small.

We guarantee our prices will save you money

FOLEY VENTILATING APPARATUS IS THE BEST

Simple in Erecting. Easiest of Operation. It Will Last a Lifetime. Its Price is the Lowest. Will Ventilate Any Size House. Prices and Circulars on Application.

Our 1908 Catalogue Greenhouse Material Sent Postpaid on Request.

THE FOLEY MFG. CO., WESTERN AVENUE 25th and 26th STS., CHICAGO

THE STANDARD STEAM TRAP

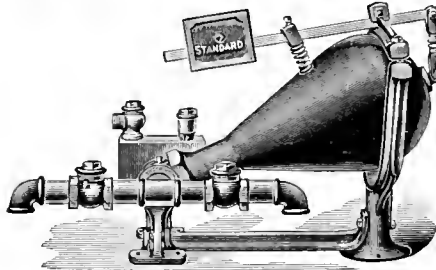

Is acknowledged the best for the florist, because it is durable and does its work without trouble and annoyance, saving its cost by the economy in coal bills.

E. HIPPARD

YOUNGSTOWN, OHIO

IRON PIPE

SECOND HAND

WROUGHT IRON PIPE, for Steam, Water, Gas or Oil, Fences or Posts. All Sizes. Price Low.

GEO. B. DOANE & SON

18 Midway Street, BOSTON
 Telephone, Main 4419

Evans 20th Century Arm



Will not twist your shafting pipe. Give it a trial and you will use no other. Three times the power of elbow arms.

Write for Catalogue

QUAKER CITY MACHINE CO.
 Richmond, Ind.

Holds Glass Firmly See the Point PEERLESS

FULL SIZE N° 2

Glazing Points are the best. No rights or lefts. Box of 1,000 points 75 cts. postpaid.

HENRY A. BREEL,
 114 Chestnut St., Phila., Pa.

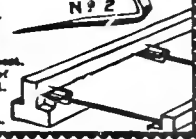

The FLORISTS' HAIL ASSOCIATION OF AMERICA, insurer of 28,000,000 sq. ft. of glass. For particulars address John C. Esler, Sec'y, Saddle River, N.J.

CYPRESS SASH BARS

82 feet or longer

HOT BED SASH

PECKY CYPRESS BENCH LUMBER

GREENHOUSES

ERECTED AND EQUIPPED COMPLETE IF DESIRED

Write for Circular "D" and Prices

The A. T. STEARNS LUMBER CO.

NEPONSET, BOSTON, MASS.

METROPOLITAN MATERIAL CO.

GREENHOUSE WRECKERS

GLASS Look at these prices. New American 50 ft. to the box, 10 x 12 single \$1.00 per box, 10x12, 12x12 B. double \$2.00 per box, 12x14 to 12x20, 14x14 to 14x20, 16x16 and 16x18 B. double at \$2.15 per box, and 16x20, 16x24, 12x24 B double \$2.25 per box. Discount on large quantities. Let us quote you on

CYPRESS MATERIAL HOTBED SASH BOILERS PIPE FITTINGS HOTBED FRAMES MATS

1398-1408 METROPOLITAN AV., BROOKLYN, N. Y.

GREENHOUSE CONSTRUCTION LUMBER

John C. Moninger Co.

117 E. Blackhawk St., CHICAGO

SAVES 25% TO 30% IN FUEL

Burns Pea or No. 1 Buckwheat Coal. Requires attention only once a day in ordinary weather (twice in severe). Write for catalogue and reason why every florist should use the

SPENCER—
The Heater that Thinks!
WEATHERED COMPANY

Sole Agents
Box 789, NEW YORK CITY
 Main Office and Works:
 Orient and West Side Avenue,
 JERSEY CITY, N. J.

Don't forget our Greenhouse Building Catalogue.
 Every type of house erected complete,
 or material only.



Here is a Greenhouse Proposition for Comparatively Little Money

It is ten feet wide and twenty-five feet long, of Sectional Iron Frame Construction, made in every way throughout in the same thorough manner as our larger houses. We have just printed a splendid little circular that describes this proposition from A to Z. Send for it.

WE MAKE EVERY PART OF A GREENHOUSE
 PUT THE GLASS. WE SELL ANY PART.

LORD & BURNHAM CO.

MAIN SALES OFFICE:

1133 BROADWAY, NEW YORK

BOSTON:
 810 Tremont Building

PHILADELPHIA:
 1215 Filbert St.

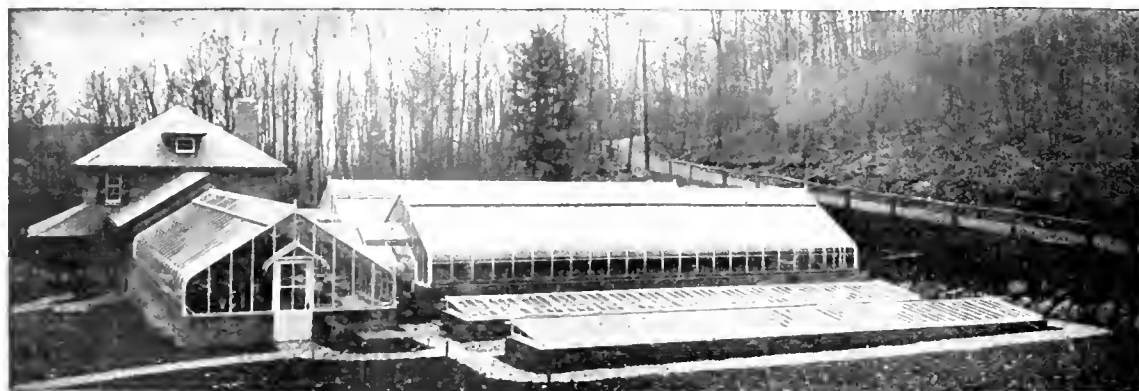

THEY ARE RIGID

because all roof and supporting members are steel, making a wonderfully strong and rigid house. They are also the lightest, simplest, most enduring, productive and attractive houses built. Send for catalog.

The ideal construction for private estates, parks, public institutions and florists' showrooms

U-BAR GREENHOUSES

PIERSON

DESIGNERS AND BUILDERS



U-BAR CO.

1 MADISON AVE. NEW YORK

HORTICULTURE

Vol. VII. MAY 16, 1908 No. 20



BACCHARIS HALIMIFOLIA

*Devoted to the
FLORIST, PLANTSMAN,
LANDSCAPE GARDENER
and
Kindred Interests*

*Published
EVERY SATURDAY
At 11 Hamilton Place,
BOSTON, MASS.
Subscription, \$1.00*

18-10-16

Dreer's Hardy Climbers

POT CROWN STOCK FOR LATE SHIPMENT

Clematis Hybrids , such as Jackmani, Jackmani Superba, Henryi, Duchess of Edinburgh, Fairy Queen, Sieboldii, Gipsy Queen, Lilacina, Fioribunda, Mme. Baron Villard, Mme. Van Houtte, Miss Bateman, Standishi, The Gem, The President and Ville de Lyon, all in strong two-year-old plants	\$3.00	\$20.00
Clematis Montana Grandiflora , new early flowering variety, very desirable	30c each	3.00
Clematis Montana Rubens , new, identical with above, except that in color it is of a soft rosy red, distinct, novel and a great acquisition	75c each	8.00
Akebia Quinata , strong two year-old plants	1.25	8.00
Ampelopsis Veitchii , strong two-year-old	1.50	10.00
Ampelopsis Virginica , strong two-year-old	1.25	8.00
Aristolochia Siphon , extra heavy	4.00	30.00
Bignonia Grandiflora , strong roots	3.00	20.00
Honeysuckles Halleana , Evergreen and Variegated, strong, 4-inch pot-grown plants	1.00	7.00
Honeysuckle Heckrothi , strong two-year old	1.75	12.00
Ipomea Pandurata , dormant roots50	4.00
Lathyrus Latifolius Albus	1.00	7.00
" " Splendens	1.00	7.00
Kudzu Vine , strong one-year-old	1.00	7.00
Schizophragma Hydrangeoides , Climbing Hydrangea, strong pot-grown plants	75c each	7.50
Wistaria Sinensis , heavy two-year-old	3.50	25.00
" " Alba , heavy two-year-old	4.00	30.00



Henry A. Dreer, ⁷¹⁴ Chestnut Street Philadelphia, Pa.

CHRYSANTHEMUMS

FOR IMMEDIATE ACCEPTANCE

I offer 100 Single Chrysanthemums for \$8.00, in 10 or more varieties.

100 large flowered kinds in 10 varieties for \$5.00. This will include some of the newer sorts and is a special cash offer open only to readers mentioning Horticulture.

CHARLES H. TOTTY,
MADISON, N. J.

ROOTED CHRYSANTHEMUM CUTTINGS

Glory of the Pacific, Polly Rose, Ada Byron, Kalb, Halliday, Harry Sinclair, Bonnalson, \$1.50 per 100.
Fair Maid Carnation Cuttings, \$1.00 per 100; \$8.00 per 1000.

H. F. Littlefield, 552 Main St., WORCESTER, MASS.

MONEY MAKERS

CHRYSANTHEMUMS—White and Yellow Bonnalson, Ivory, Rooted Cuttings, \$10.00 per 1000.
Nutt, Poitevine, Ricard and other BEST Geraniums, 4-in. stock, \$7.00 per 100.

H. L. CAMERON
North Cambridge, - - Mass.

DAHLIAS. Now is the time to place your order for bulbs which will insure you getting named varieties in any quantity; prompt delivery.

DAVID HERBERT & SON,
Successors to L. K. Peacock, Inc.
ATCO, N. J.

BAY STATE

The big sensation of all the recent Carnation Shows. A noble flower, white with carmine markings.

Now Booking Orders for Next January Delivery.

Rooted Cuttings, \$12.00 per 100, \$100.00 per 1000

ALBERT ROPER, Tewkesbury, Mass.

CARNATIONS

WINONA—The True Pink
\$12.00 per 100, \$100.00 per 1000

	Per 100	Per 1000
Red Chief.....	\$5.00	\$40.00
Aristocrat.....	6.00	50.00
Winsor.....	6.00	50.00
Beacon.....	6.00	50.00
White Perfection.....	3.00	25.00
Rose Pink Enchantress.....	3.00	25.00
Enchantress.....	3.00	25.00
Lady Bountiful.....	3.00	25.00

F. DORNER & SONS CO., LAFAYETTE, IND.

COLEUS

Verschaffeltii, Golden Queen, Fire Brand, Lord Palmerston, Queen Victoria, Beckwith's Gem. Prices of Rooted Cuttings by express, 60c, per 100; \$5 per 1000. Less than 250 of a variety will be charged at the 100 rate.

Golden Bedder, Hero, Nessey, Pearl of Orange. 75c. per 100; \$6 per 1000. Less than 250 of a variety will be charged at the 100 rate.

Fancy Varieties A very fine assortment of twelve kinds not listed above. 75c. per 100; \$6 per 1000. 250, in assortment, our selection, at the 1000 rate.

MISCELLANEOUS PLANTS

AGERATUM, Stella Gurney, Princess Pauline, SALVIA Splendens, Bonfire, HELIOTROPE, Rooted cuttings, 75c. per 100; \$6 per 1000.

CARNATIONS

Rooted Cuttings	100	1000
Winsor.....	\$6.00	\$50.00
White Perfection.....	2.50	20.00
Rose Pink Enchantress.....	3.50	30.00
Enchantress.....	2.50	20.00
Queen Louise.....	2.50	20.00

From 2 1/2 inch pots, add \$1.00 per 100.

ASPARAGUS PLUMOSUS NANUS SEEDLINGS
From flats, \$1.00 per 1000.

CHRYSANTHEMUMS

Standard varieties, ready for shipment. Rooted cuttings, \$3 per 100; \$15 per 1000. Send for list.

A. N. PIERSON, CROMWELL, CONN.

Prices quoted in these columns are for dealers only.

Begonia Gloire de Lorraine

Strong 2 1/2 in. pot plants, leaf cuttings, \$15 per 100, \$140 per 1000. Early June delivery or NOW if wanted.

S. S. SKIDELSKY, 1741 No. 18th St. PHILADELPHIA

ROOTED CARNATION CUTTINGS

Only the Best Varieties

CHICAGO CARNATION CO., JOLIET ILL.

SOMETHING GOOD

FOR SMALL PRICE

3000 2 1/2 in Salvia Splendens,	\$2.00	per 100
1000 Enchantress Carnations,	2.00	"
1000 Prosperity	2.00	"
500 Winsor	6.00	"

Very strong transplanted Asters, sure to please, at 00c per 100.

COHANZIE CARNATION GREENHOUSES, New London, Conn.

JOHN E. HAINES Bethlehem, Pa.

is the place to order rooted-cuttings of the following varieties for 1908.

John E. Haines, red Imperial variegated	Per 100	Per 1000
Pink Imperial, Pink Enchantress, Light Pink		
	\$6.00	\$50.00

Place your orders early for Jan. delivery.

DAHLIA CHARLES LANIER

BEST NOVELTY OF THE YEAR



We shall not describe it ourselves—the Press has already done so.

... WHAT THE PRESS SAYS ...

From the New York Tribune, Sept. 26, 1907.
At the Dahlia Show at the American Institute Exhibit.

Probably the most striking of the new Dahlia specimens is a brilliant yellow, its round blossoms as large as the head of a baby, from the Charles Lanier Estate at Lenox.

Standing high and proud on their long stems in a huge yellow vase in the centre of a table, these magnificent blossoms caused audible exclamations as they caught the eyes of the visitors. This is their debut in New York, although they were recently shown in Boston.

From the New York Times, Sept. 27, 1907.
Newest Specimens at the Dahlia Show.

A large number of men and women visited the big dahlia show at the American Institute, 19 West Twenty-fourth St., yesterday afternoon. There were at least

200 varieties of the finest and newest specimens of this beautiful Fall flower, and it would be impossible to tell how many colors and shades.

The most noticeable blossom was a big Charles Lanier which is known as the "show" dahlia. It is the old-fashioned quilled flower, but of a mammoth size and beautiful yellow color. This was raised by A. H. Wingett, on the estate of Charles Lanier, Lenox, Mass., and named for the proprietor. Mr. Wingett has been at work developing the plant for the last three or four years, and it has now been awarded first prize and a certificate, which is a scientific sanction of it as a new flower.

The Charles Lanier dahlia probably will be sold before the exhibition closes and should bring a good price, for it stands alone in its class.

From Horticulture, Sept. 7, 1907.

Dahlia Show at Boston.

The dahlia show at Horticultural Hall,

Boston, this week is unquestionably the finest exhibition of dahlias ever given in America.

The sensation of the show is A. H. Wingett's Charles Lanier, a four-year-old, deep yellow in color, which may be appropriately described the Col. Appleton of the dahlias. The flowers, which came in excellent condition all the way from Lenox, are shown in one of the large vases occupying the centre of the stage in the lecture hall.

From "Dahlia News," September, 1907.
New Seedling Show Dahlia "Charles Lanier."

Twenty-four enormous perfect blooms of a bright yellow were exhibited in a large Japanese vase, and in effect it equalled the best vase of Chrysanthemum. The special merit of this variety is the extreme length of stem, three feet or over, which makes it a most desirable variety for cutting. In size it equals any exhibition variety of show.

Plants to be delivered in May. Special prices to the trade only, as follows: Per dozen plants, \$3.50; 25 plants \$6; 50 plants \$11; 100 plants \$20. Orders to be filled in rotation as received.

R. & J. FARQUHAR & CO., 6 and 7 South Market St., BOSTON, MASS.

Cypripedium Curtisii Nobile



Our picture is from a plant exhibited by Wm. Kleinheinz, and awarded a certificate of merit at the monthly meeting of the Pennsylvania Horticultural Society, April 21st. This is one of Sander's novelties and came from Sumatra. It is regarded as a decided improvement over the ordinary Curtisii type, the pouch being very large, the color very deep, foliage, stem and form being of the best.

Notes from the Arnold Arboretum

The Shadbushes and the Prunus are still the dominating flowering trees and shrubs at the Arboretum. *Prunus nigra* is now passing, but as the petals change in fading from white to a pale pink color, it is in this state even prettier than when it was in its prime, presenting now a pleasing variety of color among the white Shadbushes. *Prunus orthocarpa* and *P. Watsoni* (*P. angustifolia* var. *Watsoni*), densely branched shrubs with rather small flowers are now in bloom, but must be classed among the less beautiful species as regards the flowers. A handsome and interesting species and little known in cultivation is *Prunus humilis* which was raised from seeds brought by Professor Sargent four years ago from Manchuria where he found the fruits for sale at a railroad station. The shrub is widely distributed in Manchuria, Mongolia and northern China and the edible slightly acid cherry-like bright red fruits are gathered and sold at the markets. It is a low shrub with slender branches covered with white or in the bud pinkish white flowers. Possibly it may become a valuable shrub for its fruits, but as yet we know little about their qualities and whether they will be produced here as freely as in their native habitat; it seems, however, worth a trial, particularly in the northern region of the Middle West.

The Japanese Pear, *Pyrus sinensis*, is now conspic-

uous with its large white flowers; there are a number of varieties in cultivation with large edible fruits, but it is more to be valued as an ornamental tree than as a fruit tree. *Pyrus salicifolia* is a handsome small tree with white flowers and slender partly drooping branches clothed with willow-like silvery white foliage.

The Apples are now coming into bloom and as the first *Malus Niedwetzkyana* shows its rose-purple flowers in color similar to the Red-bud but of a deeper shade. It is a low tree in habit resembling and indeed closely related to the common apple-tree, but almost every part of it, bark, wood, flowers and fruits are red, even the leaves are reddish when unfolding and turn deep red again in fall. The fruit is edible, conical-ovoid and of medium size with deep crimson-purple skin and rose-purple flesh. It was introduced from Turkestan about 1891 by Dr. Dieck of Zoesehen, Germany, and is perfectly hardy. It is to be recommended as an ornamental tree for its peculiar shade of red, unlike any other apple-tree. One of the most beautiful of the Asiatic crab-apples is *Malus Halliana* (*Pyrus Parkmanii*) which is opening now its first flowers. It forms a graceful small tree, the slender branches loaded with large pink semidouble flowers nodding on dark-colored slender pedicels; it is also handsome in summer with its dark lustrous foliage changing late in fall to dark purple. It has a particular interest for Bostonians, as the original tree from which all the trees now in cultivation have been propagated stood until a few years ago when it died on the former Francis Parkman estate in Jamaica Plain now a part of the Boston park system; it was sent to this country from Japan about 1863 by Mr. G. R. Hall after whom it was subsequently named; it also had been distributed under the name *Pyrus Parkmanii* by some nurseries. Another very handsome ornamental Apple is *Malus floribunda*, a shrub or small tree with slender spreading branches. The peculiar charm of this species consists in the pleasing contrast the deep rose-carmine flower buds form with the pinkish white color of the fully open flower and in the delicate intergrading shades of pink. As the best effect is an effect of detail this crab-apple should be planted where it can be seen at close range. More showy perhaps is *Malus Scheideckeri*, supposed to be a hybrid between *M. floribunda* and *M. prunifolia*, which has larger semidouble flowers of a lighter pink color. *Malus Toringo* is also similar to *M. floribunda*, but the flowers are smaller and usually paler except in the variety *M. Toringo* var. *atrosanguinea* which has flower buds of deep carmine color similar to those of *M. floribunda*.

The earliest of the Lilacs, *Syringa oblata*, is beginning to bloom; in flower it is not as beautiful as most of the other Lilacs, as the panicles are comparatively small and the pale mauve lilac flowers often suffer from late frosts, but its broad foliage is handsome and turns to a deep vinous red in fall. Also *Syringa hyacinthiflora* with lilac-blue double flowers in rather small panicles is opening its first flowers; this hybrid has been the starting point of most of the double-flowered varieties. Many of the varieties of *S. vulgaris* showing already fully grown panicles will open during the first warm days and mark the beginning of glorious display during the latter part of May and the beginning of June. Also the Flowering Dogwood, the Red-bud and several Rhododendrons, of the Azalea group will be in bloom soon and will add their share to the display.

Alfred Rehder

HORTICULTURE

VOL. VII MAY 16, 1908 NO. 20

PUBLISHED WEEKLY BY
HORTICULTURE PUBLISHING CO.
 11 Hamilton Place, Boston, Mass.

Telephone, Oxford 292
 WM. J. STEWART, Editor and Manager

SUBSCRIPTION PRICE

One Year, in advance, \$1.00; To Foreign Countries, 2.00; To Canada, \$1.50

ADVERTISING RATES

Per Inch, 30 inches to page \$1.00.
 Discounts on Contracts for consecutive insertions, as follows:
 One month (4 times) 5 per cent.; three months (13 times) 10 per cent.;
 six months (26 times) 20 per cent.; one year (52 times) 30 per cent.
 Page and half page spaces, special rates on application.

Entered as second-class matter December 8, 1904, at the Post Office at Boston, Mass under the Act of Congress of March 3, 1879.

CONTENTS

	Page
COVERS DESIGN— <i>Baccharis halimifolia</i> .	
CYPRIPEDIUM CURTISII NOBILIOR—Illustrated...	653
NOTES FROM THE ARNOLD ARBORETUM—Alfred Rehder	653
SOME REMEMBRANCES OF SOME POT ROSES—John Thorpe	655
AN EVIL TO BE REMEMBED—W. H. Long.....	655
BACCHARIS HALIMIFOLIA	655
A CHAT WITH ROBERT SIMPSON—Illustrated.....	656
NEWS OF THE CLUBS AND SOCIETIES:	
Society of American Florists—Massachusetts Horticultural Society	658
Florists' Club of Washington—Chicago Florists' Club—New York Florists' Club—Pittsburg Florists' and Gardeners' Club.....	659
New Orleans Horticultural Society—New Bedford Horticultural Society—The Nurserymen's Convention	660
American Rose Society—Horticultural Society of New York	662
Club and Society Notes.....	661
OF INTEREST TO RETAIL FLORISTS:	
Chicago—New Retail Flower Stores.....	666
OBITUARY—Alfred Vick—Thomas Copeland—Charles Smith	667
FLOWER MARKET REPORTS:	
Boston, Buffalo, Chicago, Detroit, Indianapolis, New York, Philadelphia, Washington.....	669
MISCELLANEOUS:	
A Boon for Cabbage Growers.....	663
Recent Business Reverses.....	662
News Notes	666-667
Business Changes	666
Personal	667
Philadelphia Notes	669
Greenhouses Building or Contemplated.....	677
Incorporated	677

Memorial Day, day of all days that the florist and gardener should pay homage to, is once more on the threshold. Garden and greenhouse, field and thicket, will give up their fragrant product for the most sublime use to which flowers can be devoted, on this great floral festival of sweet remembrance. It is a pleasure to learn from innumerable sources that the observance of Memorial Day is rapidly growing in intensity throughout

the country. The more it grows the better it will be for the common weal. Its sentiments and its lessons are, to use a popular phrase, "all to the good." So plan to bring along your flowers in greatest profusion each year for this event. There is almost no limit to the quantity that will be taken.

We have no doubt that Mr. Long's plea in another column of this paper for a Sunday of rest for the florist will find a responsive echo generally throughout the trade. The exactions of the florists' business need not be enumerated for the enlightenment of the readers whom HORTICULTURE serves. That they are almost unbearable will not be denied. That they operate against the best advancement of the art by dissuading many capable and intelligent young men from taking up the florist's business as an avocation is a logical proposition. That the closing of stores on Sunday would entail no serious loss, provided the custom is made uniform throughout the community, will be generally admitted, we think. How to bring about the needed uniformity of compliance is the problem. Compulsory closing, wherever tried, has not been permanently successful so far as we are aware. Agitation through the clubs and trade papers with a view to developing the reform sentiment among the florists themselves might in time accomplish something. It is worth trying and HORTICULTURE's columns are open to any who have views to express on this or any other topic of interest to the profession.

Secretary Rudd's communication stating the position of the S. A. F. with regard to the registration of new plant names, which appears in this issue, is timely, to the point and eminently wise. By limiting the scope of the registration bureau as indicated he will save the society much possible embarrassment and accomplish practically all that such a department can accomplish under the auspices of a society equipped as the S. A. F. is at the present time. There is an old saying that will apply here—"Let well enough alone." The S. A. F. list of registrations since the bureau was established is the best monument to the practicability of the system as conducted hitherto. The horticultural profession has found it acceptable, the plant introducers have welcomed its help, and its operations have been singularly free from friction. During the time the system has been in operation botanical authorities have been burning the midnight oil overhauling genera and species, changing old names to new ones and new ones to old ones again. The S. A. F. does well to keep out of anything that will involve it in these scientific controversies. If any one doubts this let him peruse Nicholson's list of synonyms and cross references. At this juncture it is refreshing to read in Professor Bailey's thoughtful preface to the fourth edition of his Cyclopedia, these words: "Botany, however, has declined until recently, to extend its sphere to subjects that come too near to real human affairs, and therefore has left a very large part of its domain uncultivated. Horticulture has seized some of this territory. It should hold the territory. The S. A. F. has been doing business in a simple, sensible and unpretentious method and not trying to do impossible things. That method has served its purpose well and is good enough for the S. A. F. to stick to for twenty years to come."

Some Remembrances of Some Pot Roses

Since the exhibition of the Rose Society in Chicago my thoughts have bled back to 1859-63 when I had under my charge a famous collection, bought from E. P. Francis & Co., Hertford, E., by Archibald Turner of Leicester, England. These roses had been in many fights at the London shows with the Frasers, the Waltham Cross Pauls, John and Charles Lee, and Osborne of Fulham. None were in pots larger than 11 inches and many of the plants were over 5 feet high, pyramidal in shape as to their fronts, their backs being somewhat flatter. Some of the stems at the top of the soil were thicker than my wrist notably *Camp d'Hebe*, the most beautiful pink rose even today; *Paul Perras* H. C., *Paul Ricault*, 1845, no crimson more beautiful nor of finer shape; *General Jacqueminot*, H. C., 1846, and *Madame Zoetman*. These were all on their own roots and were ten or more years old. Worked on the dog rose were *Appoline*, *Silene* (no Bon to it then), *Devoniensis*, *Harrison's Yellow*, *Jules Margottin*, *Mme. de Vatry*, *La Reine*, *Mme. Falcot* budded all over an old plant of *Lamarque* (this was new then), *Safrano* on *Solfaterre*, *Triomphe de Rennes* on *Solfaterre*; *Souvenir de Malmaison* and *Sombreuil* were budded on *Chenedolle* as was *General Jacq.*, H. P. and *Geant des Batailles*; *Niphetos* on *White Banksian* and also on *Lamarque*; *Agrippina* double worked on *Appoline*.

Nine plants exhibited at the first spring shows in 1860 averaged over 75 flowers on each. *Niphetos* and *Mme. Falcot* had close to 100 flowers on each; the *Mme. Falcot* was a sensation. These were the best exhibits in the class for amateurs. There were classes for 24 plants in 6-inch pots which used to bring out great competition. It used to take lots of manoeuvring to time the different varieties but it was done. I wish I could go over the course once more.

Some of the best new H. P. roses about then and which are yet in cultivation are *Anna Alexieff* and *Anne de Diesbach*;—the first time Reynolds saw this he remarked it was as large as a tea saucer and a little more durable—*Baron Gonella*, *Chas. Lefebvre*, *Comtesse de Chabillant*, *Empereur de Maroc*, *Eugene Appert*, *Francois Arago*, *Francois Lacharme*, *Gen'l Washington*, *Louis XIV.*,—the color of *Richmond* comes near this for brilliancy—*Mme. Boll*, *Mme. Chas. Crapelet*, *Mme. Furtado*, *Mme. Chas. Wood*, *Marechal Vaillant*, *Maurice Bernardin* and some others. Other old roses that were in this collection were *Adam*, *Comte de Paris*, *John Thorpe*, *Jules Margottin* (then new) *Mme. Bray*, *Flavescens* and *Pio Ninth*.

John Thorpe

An Evil to be Remedied

The closing of flower shops on Sundays being almost unknown to the plodding clerk whose daily bread is earned on a seven-day basis, gives rise to the time-worn question, "Why is it so?"

Truly there is no necessity for such oppression of the clerk, whose hours of labor are at all times long and tedious, as exists in most of our large cities.

The clerk can do nothing for the betterment of his condition while his employer, whose hours for going and coming are his own, and who is not forced to submit to confinement at his place of business, allows the man at the counter to be forgotten and often neglected.

There are many exceptions to this particular brand of employers, it is true, but there is often nevertheless, unpardonable negligence on the part of these as well.

There is no doubt that an agreement might be brought about by the retailers whereby all stores may close at a given hour every evening, Sundays excepted, when all places shall be closed during the entire day.

Many may laugh and many have laughed at such a proposition, but scoffers have simply to look to the several cities where Sunday closing of flower shops prevails and where employer and employe alike enjoy the much needed rest after a week of as successful and profitable business as might have fallen to the fortune of the man of fourteen hours a day plus Sunday labor.

Whatever excuse may be made in extenuation of the ungodly use of all the hours of the week for the sale of flowers the "wise one" will please direct his attention to several department stores of Greater New York where flowers are sold between the hours of 8 A. M. and 6 P. M. on week days *only*, and be advised that either of said stores purchases and disposes of a far greater amount of flowers than any single flower shop in the city.

Will the retailer help his clerk by endeavoring to crush out the evil practice of all-hour opening?

Wm. H. Long

Baccharis halimifolia

(See Cover Design.)

The Groundsel Tree (*Baccharis halimifolia*, L.) is a native shrub growing from six to nine feet in height, and may be found on sea beaches from Connecticut southward. It forms a conspicuous object in the fall by reason of the long silky white pappus which the fertile plant carries in abundance, which forms a pleasing contrast with its foliage.

The shrub is well worthy of cultivation. It has been used with good effect by the Boston Park Commission together with tamarisks, asters and solidagos for planting the borders of the waterways to the Fens. In hard winters the *Baccharis* suffers somewhat in the latitude of Boston.

A Chat with Robert Simpson

Concerning Widths of Rose Houses. Their Ventilation and Heating. Along with Some Facts About Building Greenhouses.

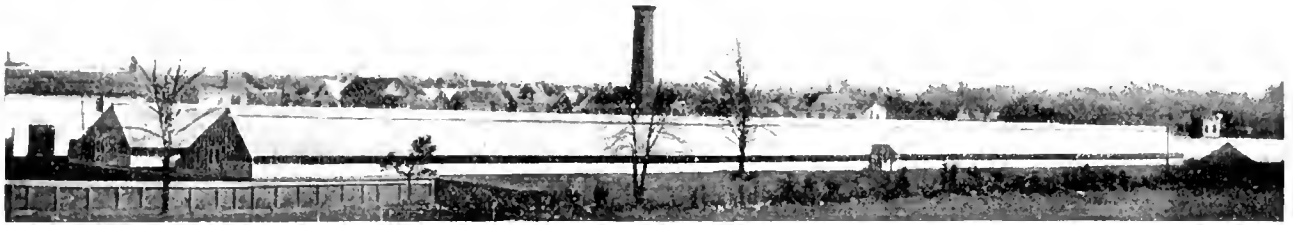

The two Sectional Iron Frame, Shadeless Ridge houses were erected in 1907. They are 465 feet long and 30 feet wide.

It had seemed to some of us that about all that could be said on various widths of houses had been said, but when Mr. Elliott came out so decidedly with his point of view at the rose convention I became convinced that there was still another side which had not been thoroughly considered. There was room for argument yet. What of the house of medium width, and does it really pay the florist to do his own erecting?

With this end in view Mr. Simpson, whose greenhouse experience, as is well known, has been long and varied, kindly consented to give up an hour or so to being "pumped," as it were. I found him just coming out of his sunny office, and after locating me in

an easy chair by the window the discussion was on.

The Best Width.

"No," said Mr. Simpson, "I never have been in favor of the extremely wide house. By extremely wide, I mean from 40 feet up. Such widths may be a little cheaper to erect, but 30 feet is as wide as I want." The average quantity and quality of bloom is actually higher in a house of this width provided it is rightly constructed."

But, Mr. Simpson, is not the whole trend of building toward wider and longer houses?

"Yes, but that doesn't actually prove anything, for this is an age when no one feels he is doing anything unless

he is outdoing what has already been done. Sometimes this tendency of the American people is carried too far and they lose the sense of actual relative values.

"Now don't misunderstand me, or quote me as saying these large houses are not splendid examples of the sectional iron-frame construction, and greatly to the credit of the builders. But contrary to an increasing belief to the opposite, I believe roses do not thrive as well when a great distance from the glass, such as is the case with the center beds in extremely wide houses.

"Careful chemical experiments I know have been made in the wide houses, with light values at various

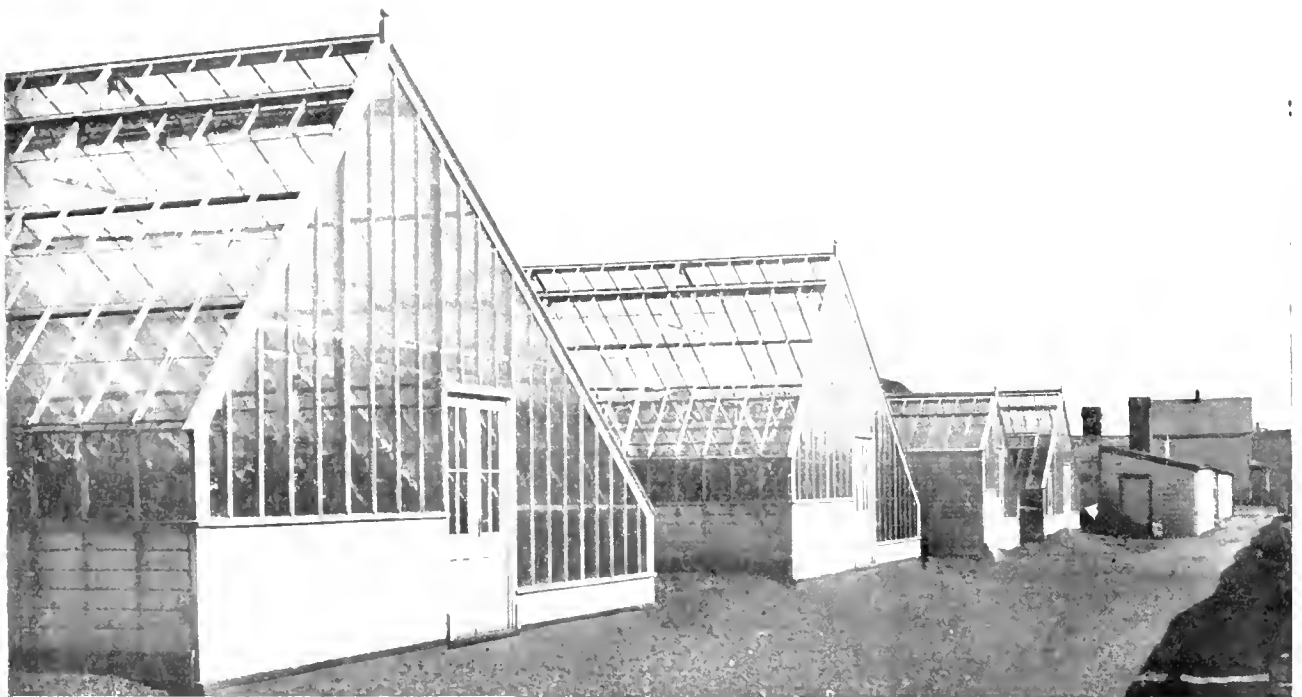

Gable view of the 30 foot Shadeless Ridge houses, with the old three-quarter span houses beyond.

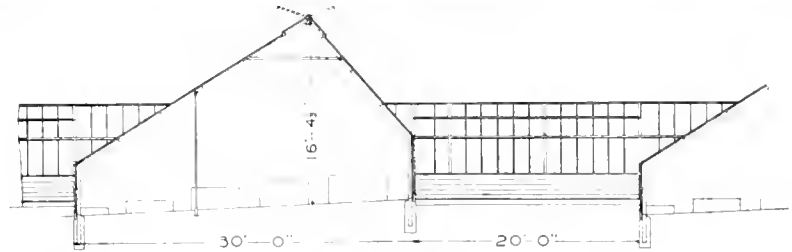
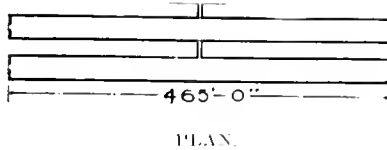

distances from the glass, and there seems to be no appreciable difference, but nature is more subtle than the arts of man and to me there is such a difference in the stock produced on the center benches of wide houses that at the Chicago Convention I could readily select such cuts. On the other hand, this apparent difference may be due to the fact that there is still something to learn about their control and the handling of stock in them."

About Ventilation.

I see that you have the self-oiling style of gears, operating only fifty feet of sash. Aren't these gears designed to handle long runs with ease?

"Yes, they are; but it is not a question of the power of the gear, but the common sense of ventilation. You see temperatures vary in different parts of the house; the ends are apt to run cooler, or in cases where connecting passages are used, as in our houses, the winds seem to suck down between the houses, strike the passages and shoot up along the roof into the ventilators. Now you see what a disadvantage long runs are in either case, as it is not alone a question of opening so many sash, but one of being able to ventilate where, and only where, ventilation is needed."

A Double Heating System.

Your foreman tells me your heating system is a combination of hot water and steam; is it cheaper?

"Well, yes, cheaper and more easily controlled. It costs more to install, but pays. I learned my lesson the first year after buying the 18-foot houses, of which this range then consisted. In some way the expansion tank pipe

became plugged and just at sundown on the edge of a cold night, out went a boiler section. We managed to gather enough oil stoves to keep the stock from freezing, and the next day the boiler was repaired. That night, out went the boiler in another house, and it was then we located the real trouble, and I decided once for all that any building I did in the future would be equipped with both steam and hot water, so if one system was disabled, the other could temporarily carry the house. Then, again, one system supplements the other in such a satisfactory way. For example, with a sudden fall in the temperature, steam can be generated in short order, and hold the houses until the slower heat of the water system is thoroughly warmed up.

"But quite as valuable is the use of steam on the cool nights in mild weather when the continued radiation of the hot water during several hours of the day is objectionable."

Objections to Home-Built Houses.

Do you believe it pays the grower to do his own erection?

"In the long run, no; and I'll tell you why. Building time generally comes at just a period when very important work is on hand which demands the florist's careful attention, and should not be slighted for other things. The raising of young stock for new rose houses is not one of the least important. A division of time means a loss either way you figure, and what little may possibly be saved in doing your own erecting, you not only lose in decrease of produce, but a good deal more. If the work has been delayed and the house not ready for planting till August, just one-twelfth of the income from your house is lost; if September, fully one-sixth, or one-third for the two months. In

addition to all this is the finish of your house—the perfect way the greenhouse people make their joints, such as at the gables, or at passage connections. If these passages are not carefully handled they soon become weak spots.

"It is the doing right of just these little things that set a house off, so you can take a pride in it and show it to your friends without a single apology, just as you do with the stock. That is the kind of roses we grow and the kind of houses I want to grow them in.

Sectional Iron Frame the Best.

"What construction do I like best? The sectional iron frame, by all means; it stays where it is put and has all the advantages of increased light and reduced repair costs, on its side.

"You may depend on it that we went into the matter with greatest care before investing in those last Lord & Burnham shadeless ridge houses, 30 feet wide and 165 feet long. Throwing the ridge further to the north than is usual brings the ridge shade on the outside walk, always entirely free from the north bench.

"While the ground on which the houses are built is level, there is an inside grade toward the north side, of 18 inches, which together with the increased height of each bench gives a total elevation of 6 inches to each succeeding bench. In this way they can be worked without raised walks, and one bench shades the other less.

"The north side is double glazed and will pay for the extra cost many times over in the coal it saves.

"Yes, Lord & Burnham houses were here when I bought the place, and I recall coming out here with some growers eighteen years ago and looking at those wooden rafter houses with angle iron purlins and we considered them model houses. These last houses might well be said to be the model construction of today."

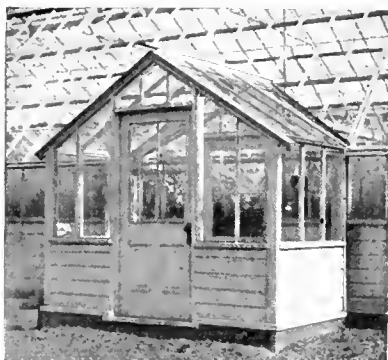

"Connecting passages if not carefully handled in the framing, make a weak spot in the houses."



The useful adoption of drain tile for a coal chute.



At the eye, the Patented Ice-Protecting plate, with sash bar clasp attached, is used.

Society of American Florists and Ornamental Horticulturists

THE QUESTION OF PLANT REGISTRATION.

So much matter has been published of late upon this subject, so much sharp criticism made, and so many have evidently failed to appreciate the purpose of plant registration that it seems desirable that the position of the Society upon this point, as understood by its officers, should be made plain.

Many of the recent writers seem to confuse the registration of a name with a certificate of merit. The writer's idea of the matter is that the act of registry has to do mainly with the ownership of the name, and in this connection the value of the plant is of no importance.

The registry of a name is an announcement to the public that a certain person has selected that name for a variety of some class of plants, and equitably vests the ownership of that name in the person registering it, always provided that some other person has not previously selected the same name for a variety of plant of the same class. The value of the plant to which he proposes to apply the name does not enter into the proposition at all. The publication of an application for registry is notice to the public at large, and the main purpose of making such publication is to cause any one having knowledge that the same name had previously been used for a variety of the same class of plants, to make that fact known.

The duplication of names, the writer ventures to assert, has been in ninety-nine cases out of one hundred, a matter of oversight or error and not an intentional deception, and while there have been many cases, since the Society first started to register varieties, in which application has been made to register a name previously used for another plant of the same class, the writer does not believe that there has been a single instance in which, when the facts were brought out by the publication of the application the duplicate name has not been promptly withdrawn and never subsequently made use of by the originator in any way. Everyone will recall numerous instances of this kind during the past few years.

We are not, of course, at this time discussing plant names from the point of euphony or utility. Setting this question aside, the only matters in which the horticulturist is interested regarding the name of a plant is first, that it shall not be a name which has previously been applied to another variety of the same class; second, that it shall not be a new name applied to a plant which has previously been given another name. The present system of registry which should comprise a scrutiny of names previously registered by this Society and a publication in all the trade papers, followed by a publication in the annual report of the Society, would seem to be about as far as it is feasible to go in guarding against the first error and has, the writer believes, proved very efficacious so far.

When the time comes that the Society has ample funds at hand, has

growing grounds to supplement them, greenhouses of sufficient extent and has in its employ and under its control a corps of expert growers and plantmen and a large collection of growing specimens, as well as a complete herbarium, it will then be in position to investigate matters pertaining to the identity of plants with a reasonable possibility of certainty in the results; but to undertake such investigations, attempt to do such work and assume to pronounce authoritatively upon such subjects now, it will inevitably be led into error, its work will be discredited and more harm will be done in the long run than any possible good which may be accomplished.

The publications of these applications for registry has brought cases of renaming to light in the past and will do so in the future. It is, of course, desirable and is the intent of the Society to require full information as to the origin of plants for which registry application is made, and to require a reasonable description of the same so there are not likely to be many cases in which a second use of the same name will escape the sharp eyes of the many shrewd plantmen who read the trade papers.

While registry is made after waiting a reasonable interval subsequent to publication, yet there is nothing to prevent complaints being filed at a later date, and while the writer is inclined to think that a registry once made and entered must stand unless properly withdrawn, yet in case of a proved error in which the person making the registry refuses to withdraw it, it would be the duty of the secretary to make public in the press and to print in the annual volume in connection with the registry, a full statement of the facts.

It is accepted in all matters of plant naming that priority of publication establishes the name. Registry by the S. A. F. fixes and records the date at which such name is selected, provides a way to authoritatively settle disputes in subsequent years, and gives notice to all persons subsequently desiring to name plants of the same class, that the name in question has been used and is to be avoided.

The foregoing sets forth so far as the writer understands it, the present intent of plant registry by this Society. Further than this under present conditions, it does not seem either feasible or desirable to go. The submission of all applications for registry to the nomenclature committee has been suggested. It might be well to state that the Society at the present time has no nomenclature committee, and it would seem a matter of great difficulty to get a committee of this kind, which would have to consist of men of great knowledge and be provided with facilities for growing, comparing and testing varieties. It would seem, I repeat, a matter of great difficulty to get such a committee, who would undertake and carry out the vast amount of work which it has been suggested should be loaded upon their shoulders, as they could be given no adequate compensation for their services.

Another question would be the long delay which would occur before any plant could be registered, and also the hostility of the introducers which would surely follow any attempt to put burdensome restrictions upon them.

It should be made easy to register plant names instead of difficult.

W. N. RUDD, Sec.

MASSACHUSETTS HORTICULTURAL SOCIETY.

The May Exhibition.

At the May Exhibition which was held at Horticultural Hall, Boston, on Saturday and Sunday, May 9 and 10, calceolarias and pelargoniums held the foreground and the narcissi and late flowering tulips made up a large proportion of the display. The calceolarias shown by James Crosbie were very handsome plants, low, compact and shapely and well furnished with large flowers of choice strain. The pelargoniums came from William Whitman and were excellent examples of the cultural skill of Martin Sullivan, gardener. From the latter also came pansies of tall, stately, late-flowering tulips as well as an extensive group of cut tulips and narcissi.

Among the most notable exhibits was a display of the well-known hardy garden phlox Miss Lingard. We have never seen this brought forward under glass before and must say it was surprisingly handsome, the flower panicles being about fifteen inches long on two to three-foot stems. They were shown by W. N. Craig, who also staged a large variety of tulips and narcissi. A fine show of Spanish irises in a number of vases of distinct varieties from Mrs. F. Ayer attracted a great deal of attention. A first-class certificate of merit was awarded to J. T. Butterworth for a shapely heavily-flowered specimen *Cattleya Mossiae*, shown under the varietal name of Mrs. Butterworth. A display of about six hundred tulips in fifty named varieties, from R. & J. Fairbank & Co., was awarded honorable mention. Harvard Botanic Garden, by Robert Cameron, filled a long table with a brilliant showing of spring flowering bulbs and other garden bloom and W. S. Spaulding, gardener E. E. Cole, contributed a fine general display of greenhouse bloom. J. R. Leeson had a group of orchids, Mrs. A. N. Blake and Mrs. E. M. Gill, pansies; W. W. Rawson & Co., tulips and daffodils; Miss Ellen A. Mansfield antirrhinums, and there was an appetizing lay-out of early vegetables from several exhibitors.

A reader expresses regret that the practice adopted a year ago of opening the library at Horticultural Hall, Boston, every Sunday, has been discontinued. On inquiry we learn that the reason for closing was the lack of visitors. If half a dozen even should make request and agree to avail themselves of this opportunity for horticultural reading the librarian would be pleased to comply.

Memorial Day

BIGGEST FLORAL HOLIDAY OF THE YEAR

WE are now booking shipping orders and if you will place them early we will fill them.

We offer a splendid stock of **Beauty, Kaiserin, Carnot, Bridesmaid, Bride, Killarney, Richmond and Chatenay Roses. Carnations, Stocks, Spiræa. Lilies, Sweet Peas. Lily of the Valley, Late Tulips, Lilacs, Cape Jessamines, etc., etc.** Also **Hardy Ferns, New Crop.**

LOWEST PRICES ON Letters, Emblems, Inscriptions, Folding Boxes, Wire Frames, Ribbons and other Florists' Supplies in complete assortment.

Welch Brothers

City Hall Cut Flower Market

226 Devonshire St., BOSTON

NEWS OF THE CLUBS AND SOCIETIES.

FLORISTS' CLUB OF WASHINGTON.

The business meeting on May 5 was followed by an entertainment. As usual Prof. Charlemagne Koehler was the chief attraction. Mr. Taylor, of the Department of Agriculture, also contributed to the evening's enjoyment. An entertainment is also planned for the next club meeting on June 2.

The Washington florists are to attend the benefit performance given at Rauscher's on May 19 for Prof. Koehler in a body. The program of this entertainment will be of a very high order, all the finest talent in Washington contributing to the evening's pleasure. The Florists' Bowling Team gives an excursion to Chesapeake Beach on June 19 for the benefit of the team. The team is to play thirty games within the next week with a view to professional work later on in the summer.

CHICAGO FLORISTS' CLUB.

The regular meeting of the Chicago Florists' Club took place Thursday, May 7. It was voted to have a picnic in July and Geo. Adams was made chairman of arrangements. There was a good attendance considering the weather. H. E. Philpot, of Winnipeg, was a welcome visitor. Out-of-town florists are invited to attend any of the meetings of the club. They are held the first Thursday of each month at the Union Restaurant.

NEW YORK FLORISTS' CLUB.

The meeting of this club on Monday evening, May 11, was attended by about forty members. Prosperity evidently prevails in the organization, for six new members were voted in and six more were proposed. The business of the evening was largely committee reports. Harry O. May read resolutions of sympathy with James Dean on the death of his daughter, which were adopted. Mr. O'Mara, on behalf of the committee on transportation to Niagara Falls, reported progress, as did Mr. Shaw for the outing committee. Mr. Riekards, for the house committee, appealed to the members to bring plenty of flowers for ladies' night, which is set for April 27. Mr. Marshall intimated that there is room in the bowling club for a few more bowlers who can score up to at least 90.

Mr. O'Mara informed the meeting that he has just accepted the appointment as chairman of a committee to be constituted by the president of the S. A. F. for the purpose of assisting and co-operating with the Census Bureau at Washington so that the next census may include comprehensive and truthful statistics of floriculture in the United States, which shall be of practical value and show the actual strength in numbers, capital and commercial influence of the florist and gardener industries. Mr. Beanlien showed vases of Mme. Peret pansies and mammoth daisies.

PITTSBURG FLORISTS' AND GARDENERS' CLUB.

At the meeting on May 5 there was much interest and enthusiasm when the committee of the private gardeners announced that \$30 would be given as prizes at the June meeting to private gardeners only, as follows: For 12 roses (outdoor), 1st \$10, 2d \$5; for 12 peonies, 1st \$10, 2d \$5. As the regular June meeting will fall on the 2d, it will probably be early for outdoor roses to be at their best, and an effort will be made to hold the meeting at a later date. A letter was received from the gardener at Rock Springs, a famous picnic resort on the Ohio River, suggesting that the club select that place for its picnic. W. A. Clarke and J. W. Jones were appointed a committee to report at next meeting. The matter of delinquent dues was taken up. This comes up yearly and is always a delicate subject to handle. According to the rules of the club, dues are payable in advance, but if neglected, notices are sent for the two following years, after which if payment is not made the name is dropped. Considering the large membership of the club the loss on this account is comparatively small.

The subject of the meeting was bedding plants. N. C. Madsen, gardener for R. H. Boggs, showed an astonishingly large and fine plant of *Calceolaria hybrida*, so thickly set with large yellow blossoms as almost to hide the foliage. Had there been prizes offered this would surely have taken first

Order Now and Order From Us



For MEMORIAL DAY



Orders given in time have always been filled complete by us. No disappointment.

NEW CROP

Dagger and Fancy Ferns

\$2.00 per 1000

LAUREL WREATHS, \$2.50 to \$3.00 doz.
FESTOONING, - - 6c a yard.

BEST QUALITY

Galax Leaves, Bronze and Green

\$1.00 per 1000 \$8.50 per 10,000

BOXWOOD, 20c per pound.

Cut Flower Department

We can fill orders for all varieties of Outdoor and Indoor Memorial Day Flowers. All grades from ordinary up to choicest, at fair prices. Don't forget the name.

HENRY M. ROBINSON & CO., BOSTON
15 PROVINCE ST., and 9 CHAPMAN PL.,

prize. Mr. Madsen is a Dane and a recent accession to the club, but his exhibits certainly cause the boys to sit up and take notice. Mr. Bartsch showed geraniums and sweet alyssum; Frank Crook, gardener for J. H. Parks, a fine specimen of *Dendrobium thyrsiflorum* and *Defiance mignonette*; Phipps Conservatories, colons and herbaceous plants.

For many years William Hamilton has been superintendent of parks at Allegheny—now Pittsburgh, North Side. Past his seventieth milestone he has tendered his resignation. He is an honored member of the club, and Messrs. Reineman, Clarke and Bader were appointed a committee to join with a committee of non-member friends in perfecting arrangements for a complimentary dinner to Mr. Hamilton.

Subject for June meeting: Outdoor roses and flowers. H. P. JOSLIN.

NEW ORLEANS HORTICULTURAL SOCIETY.

The annual banquet to members of this society was given by A. Alost at his home on Gentilly avenue, on May 3, and twenty-four members were in attendance. Mayor Behrman was the guest of honor and Secretary Panter made an admirable toastmaster. Prof. A. H. Rosenfeld, of the Crop Pest Commission, President Eble and Joseph Steckler were among the speakers. Singing followed the banquet and a vote of thanks was tendered the host for the regal reception. The chrysanthemum show which is scheduled for November 12-15 was discussed and a list of the prizes to be awarded distributed.

NEW BEDFORD HORTICULTURAL SOCIETY.

The members of this society at their meeting on Monday evening were treated to a very interesting address by Wm. N. Craig, of North Easton, on perennials. Mr. Craig considered that the herbaceous border gave more satisfaction than did the carpet beds of thirty years ago. Among a choice list of plants and bulbs recommended were *Anemone japonica*, *digitalis*, *aquilegia*, *clematis recta*, lupins of various colors, *delphiniums*, the Chinese varieties of which may be sown in June and will bloom the same year, and *phloxes*. He spoke highly of the useful character of Darwin tulips for Memorial Day and of their freedom from disease. Also of the German iris and narcissi. The *Shasta* daisy is valuable if properly and persistently culled. The broad petaled *Lilium canadense* excels in beauty and utility; if used for outdoor planting it should be planted one foot deep and if used for forcing should be well frozen before being placed inside.

Mr. Craig received a rising vote of thanks.

THOMAS WHITE.

THE NURSERYMEN'S CONVENTION.

The 33d annual convention of the

American Association of Nurserymen at Milwaukee, Wis., June 10-12, 1908, promises to be an event of unusual importance. No one interested in trees and shrubs and ornamental planting can afford to stay away. Send for membership blank to the secretary, George C. Seager, Rochester, N. Y.



CARPET BEDDING, PLANTS, BAY TREES, PALMS, AND BULBS

W. ELLIOTT & SONS
42 Vesey Near Church
NEW YORK, N. Y.

ASPARAGUS PLUMOSUS

2 inch, \$2.00 100; \$18.00 1000 | 3 inch, \$3.00 100; \$25.00 1000

for cash to close out

HUGH GRAHAM CO.,
104 So. 13th Street,

DAVID RUST, Receiver
Philadelphia, Pa.

Like the Bee so is Godfrey Aschmann, the Philadelphia Hustler, Never Idle

If you are in market for Bedding Plants GRAB THIS BARGAIN now offered for Decoration Day.

- Geraniums.** S. A. Nutt, John Doyle and assorted varieties, 4-in. pots, per 100, \$7.00.
- Agerat** m. dwarf blue, 4-in., per 100, \$7.00.
- Begonia** Vernon, the best dark red varieties, and the fine improved Erfordi, the ever-blooming variety of Europe, 4-in., per 100, \$8.00; 3-in., per 100, \$6.00.
- Scarlet Sage**, the true Bonfire or Clara Bedman, 4-in., \$8.00.
- Heliotrope**, 4-in., per 100, \$7.00.
- Fuchsias**, best varieties, 4-in., \$7.00 to \$8.00 per 100.
- Ivy**, English or Hardy, staked up, 3 feet high, 4-in., per 100, \$12.00.
- Vinca Variegata**, 4-in., per 100, \$10.00; 2½-in., \$4.00.
- Cobaea Scandens**, 4-in., staked up, per 100, \$10.00.
- Geraniums**, Mme. Salleron, for borders, strong plants, per 100, \$4.00.
- Phlox Drummondii Grandiflora**, 2½ to 3-in., per 100, \$3.00.
- Cuphea** or Cigar Plants, 2½-in., per 100, \$3.00.
- Lobelia**, Dwarf and trailing, 2½-in., per 100, \$3.00.
- Tradescantia**, 2 best varieties, 2½-in., per 100, \$3.00.
- Parlor** or German Ivy, 2½-in., per 100, \$3.00.
- Ground Ivy**, 2½-in., per 100, \$3.00.
- Verbenas**, best strain, all colors, 2½-in., per 100, \$3.00.
- Sweet Alyssum**, Little Gem or Carpet of Snow, 2½-in., per 100, \$3.00.
- Summer Chrysanthemums**, 3-in., best kinds, per 100, \$4.00.
- Nasturtiums**, best dwarf, all colors, 3-in., per 100, \$4.00.
- Centaurea Gymnocarpa**, Dusty Miller, 2½-in., per 100, \$3.00.
- Torenia Foulquieri**, 2½-in., per 100, \$3.00.
- Kenilworth Ivy**, 2½-in., per 100, \$3.00.
- Petunias**, California Giant, 3-in., per 100, \$5.00; Inimitable or dwarf, 2½ to 3-in., per 100, \$4.00.
- Marijolds** or Tagetes, Eldorado, Gold King, 3-in., per 100, \$4.00.
- Best French Candias**, about 12 superior colors, by name, very strong plants, 4-in., per 100, \$7.00 to \$8.00.
- Clematis Jackmanni**, late fall importation, 3 ft. high, nicely staked up, 35 to 40c.
- Hybrid Roses**, budded stock, late fall importation, Hermosa, 2½ to 3 feet high, Magna Charta, Paul Neyron, Mrs. John Laing, Jacqueminot, etc., Baby Rambler, 2½ to 6-in. pots, 25 to 35c.
- Araucaria Excelsa Glauca**, 6 to 7-in. pots, last spring (1907) importation, 5 tiers, 25 to 40 inches high, same in width, 6 year old, suitable for lawns and parks, \$1.75, \$2.00, \$2.50, \$3.00, \$4.00 each.
- Imported two weeks ago 5000 **Araucaria Excelsa**, 3 tiers, 6-8-10-in. high, 40c; 10-12-14-in., 50c, 60c, 75c, \$1.00 each.
- Kentia Belmoreana**, 5½-in., 20-25 inches high, 50c, 60c; 4 in., 35c. Forsteriana, large plants, \$2.50 each.

Cash with order, please. All goods must travel at purchaser's risk

Godfrey Aschmann

Importer, Wholesale Grower and Shipper of Pot Plants
1012 West Ontario St. Philadelphia, Pa.

CLUB AND SOCIETY NOTES.

At the meeting of the New London County Horticultural Society at Norwich, Conn., on May 4, Peter Zuger of Hartford gave an interesting talk on roses.

The Morris County (N. J.) Society held a ladies' night on Wednesday evening, May 13. Refreshments were served in the generous manner characteristic of this enterprising aggregation.

At the exhibition of the Worcester County Horticultural Society, Worcester, Mass., May 7, H. F. A. Lange exhibited *Salvia Zurich*, E. W. Breed hyacinths and tulips, and M. J. Whittall sweet peas and pelargoniums. There was a good showing of vegetables.

COLD STORAGE LILIES

COLD STORAGE LILIES, means that you can have Lilies all the year round. What are more useful, or give more character to the funeral piece than the Lily.

We have, and can deliver at any time cold storage Lilies—and can refer you to hundreds that are growing them, why not you?

LILIUM LONGIFLORUM GIGANTEUM is the only long-florum that gives satisfaction from cold storage—we offer them as follows:—**LILIUM LONGIFLORUM GIGANTEUM** (repacked 6 to 8 inch bulbs 400 in a case, \$8.50 per 100 \$75.00 per 1000, case of 400 for \$30.00. 7 to 9 inch bulbs, 300 in a case \$9.00 per 100, \$85.00 per 1000, \$25.50 per case of 300. 9 to 10 inch bulbs, 200 in a case, \$14.00 per 100, \$130.00 per 1000, \$26.00 per case of 200.

ARTHUR T. BODDINGTON, Seedsman, 342 WEST 14TH STREET, NEW YORK CITY

Lilium Harrisii

The best grown. Absolutely pure stock.
Free from disease. Apply at once to

GEORGE W. WEST, Shelly Bay, Bermuda

500,000 Pansies Best Market Strain Grown

Grown from seed of our own raising, this strain is the result of over 25 years' careful selection, and for size, form and substance and wide range of color in clear, brilliant selfs and novel shades and markings they will be found unsurpassed. The colors are very evenly assorted and the growth is very strong and stocky. Fall transplanted plants ready to bud and bloom.

Price, \$10.00 per 1000 Larger sizes, \$15.00 and \$20.00 per 1000
EXPRESS ONLY. CASH WITH ORDER.

I. E. COBURN, 291 Ferry St., - EVERETT, MASS.

LIVE FENCES

We believe we are the largest growers of Hedge plants in America—Privet our specialty—can supply any quantity both

Amoy River and California, strong plants, at \$25.00 per M. Other varieties. Prices on application.

PETER'S NURSERY COMPANY, - Knoxville, Tenn.

RHODODENDRONS

Hardy Hybrids — 1½ ft, 2 ft, 3 ft, 4 ft., 5 ft.

Box — All sizes Bush, Pyramid and Standard.

Roses — Large assortment, Hybrid and Climbing.

Herbaceous Perennials, 1,000 varieties

Send for General Catalog and Trade List

The NEW ENGLAND NURSERIES, Inc. BEDFORD, MASS.

Hardy Rhododendrons Azaleas Conifers, Clematis, H. P. Roses, Shrubs and Herbaceous Plants from our **HOLLAND NURSERIES**

Prices Moderate

P. OUWERKERK, 216 Jane St., Weehawken Heights, P. O. No. 1, Hoboken, N. J.

FOR SALE

5000 *Vinca Minor* "Myrtle"

EDMUND REARDON

Telephone 1034, Cambridge, Mass.

ROSES

100 of the best Hardy sorts.

HYBRID PERPETUALS

Finest English Grown Plants

Dozen, \$3.50; 100 \$25.00

EVERBLOOMING HYBRID TEAS

Bloom from Midsummer until frost.

Dozen \$5.00; 100, \$35.00

Hardy Climbing Roses

All the leading sorts.

Catalogue Free on Application.

R. & J. FARQUHAR & CO.

6 and 7 So. Market Street, Boston, Mass.

In ordering goods please add "I saw it in HORTICULTURE."

A BOON FOR CABBAGE GROWERS.

The growth of cabbage plants for late setting has been a very uncertain venture in parts of New York State for several years. Maggot-flies and flea-beetles have become so plentiful in cabbage sections that only small fractions of the seed sown give plants worth setting; so that many growers have had to import large numbers of plants from other States, with greatly increased expense and liability of introducing disease. A simple and, so far as tested, a feasible and cheap method for controlling insects on seed beds was tested, not originated, by the Geneva Station last year, and the details of the experiment are given in Bulletin No. 301. A small bed was covered with cheesecloth screening and the plants completely protected from maggots. From 1800 square feet of bed 50,000 sets were taken, while from a check plot intended to set 40 acres only plants enough for a little over 4 acres were secured. By taking off the cover for a week before setting, the plants were "hardened" so that there was no more wilting than with plants grown in the open air. The screening method is very inexpensive, and is apparently more promising than any spraying or soaking of the soil with insecticides. Cabbage growers should secure the bulletin by sending to the Station for it.

RECENT BUSINESS REVERSES.

J. D. Thompson Carnation Co., Joliet, Ill., was petitioned into bankruptcy May 5 by Gridley, Culver & King, New York.

J. W. Shadow, proprietor of the Cedar Hill Nursery and Orchard Co., Winchester, Tenn., has made an assignment to Hugh Morton, trustee.

E. L. Beard, doing a landscape gardening and nursery exchange business at 155 Milk street, Boston, made an assignment on April 28 to F. M. Smith.

P. J. Campbell, Oswego, N. Y., has added a seed department to his florist business.

Henry Richardson is in charge of the work of setting out 2000 3-year-old pine seedlings on the land recently purchased for water works at W. Concord, N. H.

Winter-flowering SWEET PEA SEED

All Colors

New crop ready in August next. Ask for list.

A. C. ZVOLANEK
ORIGINATOR. BOUND BROOK, N. J.

XXX SEEDS

CHINESE PRIMROSE. Finest grown, varieties mixed; 500 seeds, \$1; half pkt., 50¢.
CINERARIA. Finest large-flowering dwarf, mixed; 1000 seeds, 50¢.
GIANT PANSY. Best large-flowering, mixed, critically selected; 5000 seeds, \$1; half pkt., 50¢ Cash.
JOHN F. RUPP. SHIREHANSTOWN, PA.
The Home of Primroses.

BRECK'S SEEDS

For Farmer, Market Gardener and Florist
New Crop High Grade
Catalogues mailed free on application

Joseph Breck & Sons Corp
47-54 NO. MARKET ST., BOSTON, MASS.

Special Offer—FLOWERING ROOTS AND BULBS

TUBEROSES

Mammoth Pearl Pure White, First Size
Bulbs, \$8.00 per 1000.

CYCAS REVOLUTA

25 pounds, \$2.25
100 pounds, 8.50

HARDY JAPANESE LILIES

Lil. Album 8-6, per 100 \$6; 1000 \$60 | Lil. Rubrum 8 9, per 100 \$5.00, 1000 \$47.50
" 9-11, " 11; " 100 " 9-11, " 7.50, " 70.00

Headquarters for LIL. FORMOSUM

Henry F. Michell Co., 1018 MARKET STREET Philadelphia, Pa.

ASTER GROWERS ATTENTION:—

Our Seed is All Sold. If you failed to get some it is your loss. However:— Get a Competition Card Now, Enter your name as an Aster Grower of America and win part of our \$250.00 offered in prizes. Entry free. All information gladly given. No cost to you except to prepay the express charges on flowers sent in competition.

Altimo Culture Co., Canfield, Ohio.



Seeds of ASPARAGUS PLUMOSUS
NANUS, \$2.00 per 1000.

Seeds of ASPARAGUS PLUMOSUS
ROBUSTUS, \$2.00 per 1000.

COLD STORAGE LILY OF THE VAL-
LEY PIPS

JAPAN LILIES, JAPAN IRIS

For prices, state quantities required.

J. M. THORBURN & CO.
33 Barclay St., through to 38 Park Place
NEW YORK

Best Quality Fall Bulbs

It is to your advantage to place your order early. Send us a list of your wants and we will quote you rock-bottom prices. Copy of our Florists' Bulb Catalogue will be sent upon request. Catalogues now ready.

VICK'S SUPERB PANSY SEED

All the best varieties in separate colors

VICK'S SUPERB MIXTURE

the best strain from all the leading named sorts

1-8 oz. 75c. 1-4 oz. \$1.50 Ounce \$5.00

JAMES VICK'S SONS, Rochester, N. Y.

PRIMULA, FRINGED SINENSIS

This seed has been grown for us by a specialist in the culture of Primula, and he has produced plants of sturdy growth, large, thick flowers, beautifully fringed and carried on erect stems well above the foliage; unexcelled in size, substance and beautiful colors.

Giant Pe perfection strain, Finest Mixed, 1-64 oz., \$1.00
Pure White, Brilliant Pink, Blue, Chiswick Red, and
Crimson, 1-64 oz., \$1.00.

H. E. FISKE SEED CO.
13 Faneuil Hall Sq., BOSTON, MASS.

C. C. MORSE & CO.

Address all communications to our permanent address
48 to 56 Jackson St., San Francisco, Cal.

The Largest Seed Growers
in the United States

RELIABLE SEEDS

SOW NOW

Ageratum Mexicanum Blue Star—

Tr. Pkt. 25c; 6 Tr. Pkt., \$1.25.

Lobelia Erinus Pendiculata Hamburgia

Tr. Pkt. 30c; 6 Tr. Pkt., \$1.50.

Primula Obconica Grandiflora—

New Hybrids: Blood-red, Blue, Carmine, Pink, Purple, Violet, Pure-white, Compacta, Gigantea, Fringed Mixed Hybrids, each separate, Tr. Pkt. 50c; 6 Tr. Pkts., \$2.50.

My Catalogue will guide you through Reliable Seeds. Ask for Same.

O. V. ZANCKEN

SEEDSMAN, HOBOKEN, N. J.

JUST ARRIVED

LARGE SHIPMENT OF

High-Grade SCOTCH SOOT.

We have the **Stott Double Nozzle**
THOMAS J. GREY CO.

32 & 33 So. Market St., BOSTON

BRIDGEMAN'S SEED WAREHOUSE

RICKARD SBROS,

Props.

37 East 19th St., - NEW YORK CITY

BRASLAN SEED GROWERS CO.

GROWERS FOR THE

WHOLESALE TRADE ONLY

SAN JOSE, - - CALIFORNIA

CAULIFLOWER^S CABBAGE^E ED

HJALMAR HARTMANN & CO.,
12 Stormgade,
COPENHAGEN, DENMARK.

Burpee's Seeds

PHILADELPHIA

Blue List of Wholesale Prices mailed only to those who plant for profit.

HYDRANGEA OTAKSA

Large Plants in Tubs and Half-barrels for July and August Flowering

We make a specialty of these, and have a magnificent lot of large plants, which we can supply in any quantity—from single plants up to carload lots. **Large plants in tubs, \$2 and \$3 each. Extra large plants in half-barrels, \$5 and \$7.50 each.** We can supply, also, a fine lot of plants in 6-in. pots, now in bud and bloom, fine for immediate sale or Decoration Day trade, at **\$5 per dozen.**

VINCAS and ENGLISH IVIES. Extra fine plants in 3½ and 4-in. pots, for vases, tubs, etc. **\$8 per 100; extra size, \$10 per 100.**

FRENCH MARGUERITES in bloom. Large plants, 6-in. pots, extra fine, **\$5 per dozen.**

CANNAS. Started plants in 3½ and 4 in. pots, ready for immediate planting. Mme. Nardy, Mlle. Berat, Robert Christie, Golden King, Pennsylvania, L. Patry, Florence Vaughan, Pandora, Austria, Souv. d'Antoine Crozy, Kohalium, Pierson's Premier, Queen Charlotte, Frederick Benary, etc. **Extra strong plants, \$6 per 100**

PANSIES, ENGLISH DAISIES, and FORGET-ME-NOTS. **\$3 per 100.**

CROTONS for bedding. Extra strong plants, 3½-in. pots, **\$25 per 100; 5-in. pots, \$50 per 100.**

ACALYPHA RUSSICA. Extra choice, for bedding. 2½-in. pots, **\$6 per 100.**

PANDANUS VITICIFOLIUS. 5-in. pots, **\$9 per dozen; 6-in. pots, \$12 per dozen; larger plants, \$2 to \$3.50 each—according to size.**

FICUS ELASTICA. 5-in. pots, **\$4 per dozen; 6-in. pots, \$6 per dozen.**

DRAENA FRAGRANS. Extra large plants in 6-in. pots, 3 ft. high, **\$12 per dozen.**

FERNS, Assorted. Extra heavy plants, 2½-in. pots, **\$3 per 100; 3½-in. pots, extra heavy, \$10 per 100.**

NEPHROLEPIS PIERSONI ELEGANTISSIMA. 2½-in. pots, **\$6 per 100; 3½-in. pots, \$15 per 100; 6-in. pots, \$6 per dozen; 8-in. pots, \$12 per dozen.**

BOXWOOD, Pyramids. Extra fine plants, **\$2 and \$3 each.**

CARNATIONS, Winsor and White Enchantress. We can supply these in quantity, ready for immediate planting. Strong established plants from 2½ in. pots, **\$7.50 per 100; \$60 per 1000.**

F. R. PIERSON CO., Tarrytown-on-Hudson, New York

The Roses that Win

MRS. POTTER PALMER, CARDINAL American Beauty and Other Standard Varieties. Rooted from Our Famous Stock. Send for Prices.

POEHLMANN BROS. CO.
Morton Grove, Ill.

ROSES

A SPECIALTY

The Dingee & Conard Co. West Grove PA.

RHEA REID

READY NOW, Own Root, \$30 per 100. Grafted, \$35 per 100.

AMERICAN BEAUTY

Fine Young Stock, \$6 per 100, \$50 per 1000.

THE E. G. HILL CO., Richmond, Ind.

AMERICAN NURSERY CO., COMBINING

FRED'K W. KELSEY, New York City
F. & F. NURSERIES, Springfield, N. J.
BLOODGOOD NURSERIES, Flushing, L. I.
N. J. & L. I. NURSERIES

We can supply you every need. Write for prices
Sales Department

150 BROADWAY, - NEW YORK

CARE OF TREES

12 years' experience. Endorsed by the United States Department of Agriculture. Graduates of Agricultural Colleges and Schools of Forestry. Field force of 250 expert men. Everything to do with trees,—pruning, removing dead wood, treating and closing cavities, spraying for both insects and diseases, fertilizing, forest planting, tree moving, etc. Write us.

H. L. FROST & CO.

Landscape Foresters and Entomologists.
White Plains, N. Y. Arlington, Mass.

Berberis Thunbergii

18 to 24-in., 12 to 16-in., all well branched and good roots. 10,000 Vinca Minor (Grave Myrtle), 5000 Red Oak, 3 to 5 ft. Norway Spruce, 12 to 18-in.

OAK HILL NURSERIES, Roslindale Mass.

FINEST LOT OF

HARDY HYBRID RHODODENDRONS

ALSO DWARF RHODODENDRONS
ANDROMEDA FLORIBUNDA

READY FOR IMMEDIATE SHIPMENT
ORDER TODAY

EASTERN NURSERIES, JAMAICA PLAIN, MASS.

JOHN WATERER & SON, Ltd.

American Nursery, Bagshot, England

Are Specialists in the

REALLY HARDY VARIETIES

of Rhododendron Hybrids and in Select Varieties of Hardy Border Plants.

HARDY NORTHERN GROWN NURSERY STOCK

At Reasonable Prices

FRUIT AND ORNAMENTAL TREES, SHRUBS, VINES, ROSES AND
HERBACEOUS PERENNIALS IN GREAT VARIETY

Catalogue and Price List for the asking

BAY STATE NURSERIES, NORTH ABINGTON, MASS.

NEW — NEW

RAMBLER ROSE "NEWPORT FAIRY"

To be disseminated Spring, 1908. Ask for Illustrated pamphlet and prices

JULIUS ROEHRS CO., Rutherford, N.J.

Prices Quoted in these Columns are for Dealers Only. When Writing to Advertisers Please Mention HORTICULTURE.

ORCHIDS

Just Arrived in Fine Condition

ORCHIDS



ONE of the largest consignments of plants ever received in the United States at one time; namely, 100 cases Cattleya Trianae, 80 of Cattleya labiata, 40 of C. gigas Sanderiana. Fine importation of Cattleya Schroederiae, C. Harrisoniae, C. citrina, Laelia anceps, Oncidium varicosum Rogersii, O. tigrinum, O. ornithorhynchum, Odontoglossum Insleyii, Odonto. Rossii majus, Dendrobium formosum giganteum, D. Wardianum. To arrive shortly, D. Phalaenopsis, Cattleya Mossiae, C. Percivalhana, C. Gaskelliana, C. Mendelli, C. Warneri. Intending buyers of Orchids would do well to come and see this stock before buying elsewhere. Our prices are reasonably consistent with good stock. All our goods are collected by our own collectors, thereby assuring our customers the best stock the forests afford. Come and see them. These goods if potted at once will yield abundance of flowers the first year, paying for the cost of the plants in the fall.

We also carry a large stock of established Orchids. Also orchid peat, Sphagnum Moss, Baskets, etc. A trial will prove we carry the best stock that can be secured. Come and see for yourself and be convinced of these facts.

Carrillo & Baldwin SECAUCUS, N. J.

HOW TO REACH OUR PLACE—Take Erie R. R. to Homestead, N. J., 3 minutes by trolley to Secaucus; or by trolley from D. L. W. depot, Hoboken, 25 minutes get off post office Secaucus. From Penn. depot, Jersey City, take train on Susquehanna R. R. to Homestead.

ORCHIDS

HYACINTHS, TULIPS, NARCISSI AND OTHER BULBS

ROMAN HYACINTHS and the true PAPER WHITE GRANDIFLORA

Ask for our Wholesale Trade List at Hillegom

K. VELTHUYS, Hillegom, Holland
Rep. by FELIX BOSCH, 260 Clarendon St., Boston.

In ordering goods please add "I saw it in HORTICULTURE."

HIGH GRADE DUTCH BULBS W. J. ELDERING & SON

Overveen, Haarlem, Holland

Special Quotations on large quantities. Wholesale Only.

New York Address HOTEL SEVILLE

ROBERT CRAIG CO.

ROSES, PALMS,

and Novelties in Decorative Plants

MARKET and 49th STREETS., PHILADELPHIA, PA.

ROSES

Strong, Clean Stock. Grafted, Killarney, Richmond, Brides and Maids \$12.00 per 100, \$110.00 per 1000.

Own Roots, Brides, Maids, Gates, Ivory, Perle, Killarney and Richmond. \$6.00 per 100, \$55 per 1000. All from 3 1/2 in. pots. P. R. QUINLAN, Syracuse, N. Y.

AZALEAS

for fall delivery, the best that are grown, also AUGUST HAERENS, Somergem, Belgium; orders booked now.....

PALMS for spring or fall delivery, furnished by Belgium; orders booked now.....

AUGUST ROLKER & SONS, 31 Barclay Street, or P. O. Box 752, New York

RUBBERS 4 inch pots. \$20.00 per 100, \$2.50 per dozen.

ARAUCARIAS Nice 4 inch stock, 40c. Larger 50c, 75c, \$1.00

BEDDING PLANTS Geraniums, 4 inch Single and Double Dryden, \$8.00 per 100. Other varieties at \$7.00 per 100. Salvia Zurich and Bonfire, Lobelia Katbleen Mallard and all other new and standard bedding stock in best quality at lowest market rates.

JOHN MCKENZIE
North Cambridge, Mass.

In ordering goods please add "I saw it in HORTICULTURE."

NEPHROLEPIS SCOTTII

in the following sizes, extra good value 25c., 50c., 75c., and \$1 Grand Specimen Plants at \$3, \$4, \$5, \$6.

JOHN SCOTT
Rutland Road and E. 45th st. Tel. 2390 Bedford BROOKLYN, N. Y.

NEP. WHITMANI 2 1/4 in., \$5.00 per 100

NEP. WHITMANI 3 1/2 in., \$25.00 per 100

BOSTON FERNS 2 1/4 in., \$3.00 per 100

H. H. BARROWS & SON Whitman, Mass.

ORCHIDS

We advise the Growers and Private Places that our Importations will begin to arrive in a few weeks' time and we will have the following: C. gigas, C. gigas Sanderiana, C. Mendelli, C. Schroederiae, C. Trianae, C. Gaskelliana, C. Percivalhana, C. aurea, Miltonia vexillaria, C. Mossiae, C. spectabilissima, C. labiata and others. We guarantee that our plants will be extra fine with no disease or Cattleya fly and will quote the Lowest Prices in America.

URBON & SONS., MADISON, N. J.

ORCHIDS

Largest Importers, Exporters, Growers and Hybridists in the World

Sander, St. Albans, England and 235 Broadway, Room 1 NEW YORK CITY

Imported Orchids

JUST TO HAND Laelia Purpurata, Cattleya Intermedia, Cattleya Mossiae, Cattleyas Trianae and Mendellii, Dendrobium Wardianum, Oncidium tigrinum and splendidum.

JULIUS ROEHR'S CO.,
The Orchid Nurseries RUTHERFORD, N. J.

ORCHIDS for Spring Delivery

NEW IMPORTATIONS Cattleyas, Laelias, Oncidiums, etc. WRITE FOR PRICES

Now is the time to Pot Orchids. Best Quality of Peat, Moss and Baskets on hand.

JOSEPH A. MANDA, 191 Valley Road, WEST ORANGE, N. J.

ORCHIDS

arrived in superb condition Cattleya Trianae, C. labiata C. Mossiae, Oncidium Varicosum, Vanda Coerulea, Dendrobium Formosum and D. Dalhousieanum.

LAGER & HURRELL, Summit, N. J.

JOHN BREITMEYER'S SONS

Cor. Miami and Gratiot Aves.
DETROIT, MICH.

Artistic Designs . . .
High Grade Cut Blooms

We cover all Michigan points and good
sections of Ohio, Indiana and Canada

William J. Smyth FLORIST

Cor. Michigan Ave. and 31st St., CHICAGO

We ship to all points in Illinois and Iowa.

Phones: Douglas 744, Douglas 523, Douglas 740

M. C. and J. E. HAUSWIRTH

232 Michigan Ave.
CHICAGO

AUDITORIUM ANNEX Tel. Harrison 585

SAMUEL MURRAY Florist

Coates House Conservatory
1017 BROADWAY, KANSAS CITY, MO
Both 'Phones 2670 Main

FRED C. WEBER FLORIST

4326-28 ST. LOUIS, MO.
OLIVE STREET
Established 1873
Long Distance Phone Bell Lindell 676



WASHINGTON,
D. C.

GUDE'S

Geo. H. Cooke FLORIST

Connecticut Avenue and L Street
WASHINGTON, D. C.

The Park Floral Co.

J. A. VALENTINE
Pres.

DENVER, COLORADO

WILLIAM L. ROCK FLOWER CO.

KANSAS CITY, MO.

will carefully execute orders for Kansas City
and any town in Missouri or Kansas.

Of Interest to Retail Florists.

Bulbous stock is now
CHICAGO practically out of the
question. Azaleas also
are about gone, while rhododendrons
are to be had in limited quantity only.
Hydrangeas, too, are in short supply,
so it leaves the market comparatively
bare of blooming plants. The mar-
guerite Queen Alexandra is one good
plant that helps out at this time and
the growers consider it a fine thing.
The large flowers and branching habit
make it very distinct from the
ordinary marguerite. Geraniums,
heliotrope, mignonette and all bedding
and pot stock are beginning to put in
an appearance and will soon be in de-
mand with a good supply in sight.
Boston ferns, asparagus and other
greens in pots are in active demand.

NEW RETAIL FLOWER STORES.

Lewis R. Jackson, 14 Montvale
avenue, Woburn, Mass.

NEWS NOTES.

Mrs. C. M. Kerlin will act as agent
at Delhi, Ind., for F. Dornier & Sons
Co.

John Donaldson has been elected
president of the New York Cut Flower
Exchange.

W. H. Knowlton of East Hamilton,
Mass., has added plants and flowers to
his market gardening business.

George Gebhard, who sold out his
florist business several years ago, is
starting again at Mt. Airy, Philadel-
phia, Pa.

The J. H. Rebstock Co., Buffalo, N.
Y., have vacated their Main street
store and are now located at the
Elmwood Avenue Greenhouses.

The Florists' Supply Co., 20 Well-
ington St., West, Toronto, Can., is a
new wholesale cut flower house, started
by George J. and Fred C. Brown.

Rowland Cloudsley, formerly with
Wm. Scott Co., has leased the store
at 584 Main street, Buffalo, N. Y., and
expects to open it at an early date.

BUSINESS CHANGES.

The Athens Floral Co., Athens, Ga.,
has moved to Hazelton's Music Store,
College Ave.

The Floral Exchange has moved its
office from 335 N. Sixth St., Philadel-
phia, to North Wales, Pa.

Herman Wicking, Jr., succeeds
Wm. Trefinger as manager of the
Wicking Greenhouses, Bluffton, Ind.

Hiram McFeron has purchased the
interest of his partner and will con-
tinue the nursery business of Kelly
& McFeron at Columbus, Ind.

We read in the columns of two of
our esteemed contemporaries that the
dwarf Polyantha rose Apple Blossom
is a sport from Crimson Rambler?
Guess again.

Florists

Out of
Town

Taking orders for delivery in
New York or Vicinity
can have them filled in best
manner and specially deliv-
ered by * * *

Thomas Young, Jr.

500 Fifth Ave., New York City
Telephone 847 Bryant.

ALEX. McCONNELL

571 FIFTH AVENUE
NEW YORK CITY

Telegraphic orders forwarded to any
part of the United States, Canada, and
all principal cities of Europe. Orders
transferred or intrusted by the trade to
our selection for delivery on steamships
or elsewhere receive special attention.

Telephone Calls, 487 and 488 38th St.
Cable Address, ALEXCONNELL

WILLIAM H. DONOHOE

FLORAL DECORATOR

17 East 28th St., New York
Special Attention to Theatre
and Steamer Orders, and reliable
deliveries guaranteed.

DAVID CLARKE'S SONS

Deliver orders from any part of the country to
New York City

Or OUT-GOING STEAMERS

Write or telegraph

2139-2141 Broadway, New York
Telephone 1552-1553 Columbus

M. A. BOWE

In the Heart of New York City

1294 Broadway

Tel. 2270, 38th St. NEW YORK
Our Motto -- The Golden Rule.

YOUNG & NUGENT

42 West 28 St., NEW YORK

"FLOWERS BY TELEGRAPH"

Flower Deliveries

In Brooklyn and other Long Island Points
New York City, New Jersey, etc. At Theatres,
Hotels, Steamers or Residences.

WILSON

Fulton St. and Greene Ave., Brooklyn, N.Y.

ALBANY, N. Y.

EYRES

Flowers or Design Work

DELIVERED IN ALBANY AND VICINITY
ON TELEGRAPHIC ORDER.

11 NORTH PEARL ST., ALBANY, N. Y.

JACOB SCHULZ, 644 Fourth Ave.,
LOUISVILLE, KY.
Cut Flowers of BEST QUALITY in season
delivered promptly to any address.

Write, Telegraph or Telephone.
Cumberland and Home Phones 223 and 984

**PROMPT DELIVERY IN
BOSTON**
AND ALL NEW ENGLAND POINTS
HOUGHTON & CLARK
396 Boylston St., Boston, Mass.



BOSTON'S BEST
In Quality and Design
Can be relied upon when you transfer your retail orders to

EDWARD MACMULKIN
194 Boylston Street, Boston

Send flower orders for delivery in
BOSTON
and all
NEW ENGLAND POINTS
THOS. F. CALVIN
124 Tremont St., Boston

TRANSFER
Your orders for flower or plant delivery in Eastern New England to
JULIUS A. ZINN,
2 Beacon St., Boston.
Fine Design Work a Specialty

YALE Orders for flower deliveries to Yale College and all other Connecticut points carefully filled and delivered by
J. N. CHAMPION & COMPANY
1026 CHAPEL STREET NEW HAVEN, CONN.

Chicago. Established in 1857
WITTBOLD
FLORIST
1657-1659 Buckingham Place
L. D. Phone 558 Lake View. Send us your retail orders. We have the best facilities in the city.

The Far-Famed Flowers of
TORONTO
Delivered on mail or telegraph order for any occasion, in any part of the Dominion.
JOHN H. DUNLOP,
96 Yonge St., Toronto, Ont.

ATLANTA FLORAL CO.
41 Peachtree Street, ATLANTA, GEORGIA.

There are some
GOOD BARGAINS
listed in the
BUYERS' DIRECTORY,
Pages 672 to 676 this week.

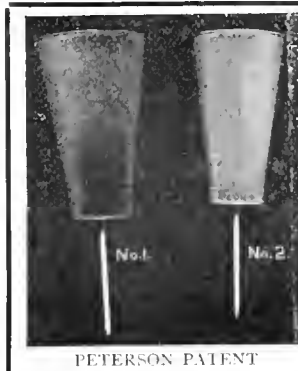

**WHITE OR GREEN ENAMELED
CEMETERY or LAWN
CUT FLOWER VASES**

These will give perfect satisfaction to your customers.
Made in 2 sizes at the following prices:
No. 1. \$15.00 per 100; \$2.00 per dozen
No. 2. 12.00 " 1.60 "
Let us send you a trial order and convince you of their superiority. Less 10 per ct. for cash with order.
WM. F. KASTING CO., - Wholesale Florists
Sole Owners of Patent
383-387 Ellicott Street, BUFFALO, N. Y.
Carried by all the leading Florist Supply Houses in the country.

HART'S HANDY HANDLE
"At Easter-time, with a little chiffon decoration, and the Handle, we were able to increase the value of plants from 50% to 100%."—H. E. WILSON.
Write for descriptive circular and prices
GEO. B. HART, 24 Stone St., Rochester, N. Y.

OBITUARY.

Alfred Vick.
Alfred Vick, brother of C. H. and Fred W. Vick, died at his home in Mt. Carmel, Conn., on April 28.

* **Thomas Copeland.**
Thomas Copeland of Sewickley, Pa., died at his home in Leetdale on May 6. He was born in Scotland, and after coming to this country in 1871 was connected with the Northside parks. For 28 years he conducted a florist stand at the Fert Wayne station, Sewickley. Four sons and two daughters survive him.

Charles Smith.
Charles Smith, a well-known wholesale flower dealer at the New York Cut Flower Exchange, died at his home in Bound Brook, on April 30, after a week's illness with pneumonia. Mr. Smith was born in London. After coming to this country he followed the retail flower business for a time and then started as a grower at Long Island City and later at Woodside and two years ago started another establishment at Bound Brook, N. J. His age was 63. He leaves three sons and three daughters.

NEWS NOTES.

A miniature cyclone which swept over Keene, N. H., on May 5, lifted the roof from the greenhouse of W. M. Foley, wrenched seven ventilators from their places and destroyed about a hundred lights of glass besides injuring many of the plants on which the broken glass was thrown. The tempest came without warning and was over in a few moments.

Mt. Auburn Cemetery, Cambridge, Mass., has established recently a department of forestry and ornamental planting. Under G. Bleicken, who is in charge, 50,000 shrubs have been propagated this winter and heavy orders have been given for hybrid roses and rhododendrons. A U-Bar propagating house, 40 x 60, finished a short time ago, is giving great satisfaction.

PERSONAL.

Visitors in Buffalo: E. J. Fan-court, Philadelphia; C. E. Ford, Philadelphia.

Charles S. Grover has been chosen commissioner of Pine Grove Cemetery, Lynn, Mass.

Visitors in Boston: David Lumsden, Durham, N. H., H. R. Mitchell, Waterville, Me.

E. L. Bates has been appointed manager of Mrs. S. A. Moir's store, Brockton, Mass.

A. L. Rose, Boston, landscape architect, has taken a position with the Hoyt Nursery Co., Minneapolis, Minn.

The engagement is announced of Frank Edgar, of the W. W. Edgar Co., Waverley, Mass., and Miss Marguerite Burbeck.

W. Wilson, of Niagara Falls, Ont., who has been connected with Queen Victoria Park, has been appointed park commissioner of Toronto.

You will find something worth reading on every page of HORTICULTURE.

BOSTON FLORIST LETTER CO.
Manufacturers of FLORISTS' LETTERS

This wooden box nicely stained and varnished, 18x30x12, made in two sections, one for each size letter, given away with first order of 500 letters
Block Letters, 1 1/2 or 2 inch size per 100, \$2.
Script Letters, 3. Fastener with each letter or word. Used by leading florists everywhere and for sale by all wholesale florists and supply dealers
N. F. MCCARTHY, Manager
66 Pearl Street, BOSTON, MASS.

GREENS for DECORATION DAY

New Crop Dagger Ferns, \$2.00 per 1000.
Bronze and Green Galax, \$1.00 per 1000,
\$7.50 per case.
Leucothoe Sprays, bronze or green, 75c per
100, \$6.50 per 1000.

The Leo Niessen Company
1209 Arch St., Philadelphia, Pa.
Open from 7 a. m. to 8 p. m.

VALLEY

Choicest, \$4.00 per hundred, \$30.00 per thousand

CEDAR BARK

For covering window boxes, \$1.00 per bundle

Peonies for Decoration Day

Prices on application

S. S. PENNOCK-MEEHAN CO.
1608-1620 Ludlow St. PHILADELPHIA
"The" Wholesale Florists of Philadelphia

EVERYTHING SEASONABLE IN
CUT FLOWERS
EDWARD REID, Wholesale Florist
1526 Ranstead St., PHILADELPHIA
STORE CLOSES 8 P. M.

CHAS. W. McKELLAR

51 WABASH AVE., CHICAGO

Western Headquarters for Choice Orchids
Valley, Roses and all Cut Flowers

PETER REINBERG WHOLESALE

CUT FLOWERS

51 Wabash Av., Chicago, Ill.

CUT FLOWER BOXES
EDWARDS FOLDING BOX CO
MANUFACTURERS
PHILADELPHIA, PA.

AMERICAN BEAUTY and all other ROSES

LILY OF THE VALLEY, CARNATIONS

WELCH BROS., 226 Devonshire St., Boston, Mass.

SWEET PEAS

Never better than at present, good stem, good color, moderate price.

W. E. McKISSICK WHOLESALE FLORIST
PHILADELPHIA
1619-1621 RANSTEAD ST.

DAILY CONSIGNMENTS

From 40 to 60 Growers

We can care for your cutflower wants to advantage.

E. F. WINTERSON CO.
45-47-49 WABASH AVE., CHICAGO

Rice Brothers

115 N. 6th Street, MINNEAPOLIS, MINN.
WHOLESALE FLORISTS and SUPPLIES
CUT FLOWERS received twice daily, and can fill your orders to your satisfaction. A complete line of Hardy Greens - WILD SMILAX, BOXWOOD, HARDY FANCY FERNS, GALAX LEAVES.
Write for quotations on large quantities.

H. BAYERSDORFER & CO.

The Florists' Supply House of America

Send for Illustrated Catalogue
1129 ARCH ST., PHILA., PA.

TOWER HOTEL

Niagara Falls, N. Y.

is soliciting your patronage during the S. A. F. Convention.

Very truly yours,
M. J. HOENIG, Prop.

WHOLESALE FLOWER MARKETS—TRADE PRICES—Per 100 TO DEALERS ONLY

	CHICAGO May 12		TWIN CITIES May 11		PHILA. May 11		BOSTON May 13	
ROSES								
Am Beauty, Fancy and Special...	25.00	to 30.00	25.00	to 35.00	20.00	to 25.00	15.00	to 20.00
" EX. 1a.....	25.00	to 20.00	13.00	to 25.00	13.00	to 15.00	12.00	to 15.00
" No. 1.....	10.00	to 12.00	10.00	to 15.00	8.00	to 10.00	6.00	to 10.00
" Lower grades.....	5.00	to 10.00	6.00	to 8.00	3.00	to 5.00	4.00	to 6.00
Bride, 'Maid, Fancy & Special....	5.00	to 6.00	6.00	to 8.00	6.00	to 8.00	6.00	to 8.00
" " Extra and No. 1.....	4.00	to 5.00	3.00	to 5.00	3.00	to 5.00	3.00	to 5.00
" " Lower grades.....	3.00	to 4.00	1.00	to 3.00	1.00	to 2.00	1.00	to 2.00
Killaroe, Richmond, Fan. & Sp....	6.00	to 8.00	7.00	to 12.00	8.00	to 12.00	8.00	to 10.00
" " Lower grades.....	4.00	to 6.00	4.00	to 7.00	2.00	to 5.00	2.00	to 6.00
Chat-day, Wellesley, Fan. & Sp....	6.00	to 8.00	5.00	to 8.00	8.00	to 12.00	4.00	to 6.00
" " Lower grades.....	4.00	to 6.00	3.00	to 5.00	2.00	to 5.00	1.00	to 3.00
Golden Gate Ivory.....	4.00	to 6.00	3.00	to 8.00	2.00	to 6.00	1.00	to 6.00
CARNATIONS								
Fancy and Novelty.....	3.00	to 4.00	2.50	to 4.00	1.50	to 3.00	2.00	to 3.00
Ordinary.....	2.00	to 3.00	1.50	to 2.00	.75	to 1.00	.50	to 1.00
MISCELLANEOUS								
Violets.....	.50	to 1.00	to	to25	to .50
Cattleyas.....	40.00	to 50.00	to 50.00	to 60.00	50.00	to 60.00
Cypripediums.....	to	to	to	8.00	to 10.00
Lilies.....	8.00	to 10.00	10.00	to 12.00	8.00	to 10.00	6.00	to 8.00
Lily of the Valley.....	3.00	to 4.00	3.00	to 4.00	1.50	to 3.00	1.00	to 3.00
Daisies.....	.60	to 1.75	.50	to 1.25	.50	to 1.00	to
Daffodils.....	2.00	to 3.00	1.50	to 2.50	2.00	to50	to 1.00
Tulips.....	2.00	to 3.00	1.50	to 2.50	2.00	to 3.00	.50	to 1.00
Mignonette.....	1.00	to 3.00	3.00	to 4.00	2.00	to	1.00	to 2.00
Gardenias.....	1.00	to 1.50	20.00	to 30.00	20.00	to 25.00	12.00	to 25.00
Lilac per bunch.....	.35	to .50	.75	to 1.00	10.00	to 25.00	.50	to .70
Sweet Peas.....	.40	to 1.00	.60	to .75	.50	to 1.00	.25	to .50
Adiantum.....	.60	to 1.25	.75	to 1.00	1.00	to 1.50	1.00	to 1.55
Whitmaoiti Fronds.....	to	to	3.00	to	2.00	to 3.00
Smilax.....	to 15.00	12.00	to 15.00	15.00	to 20.00	10.00	to 12.00
Asparagus Plumosus, striggs.....	35.00	to 75.00	35.00	to 50.00	40.00	to 50.00	25.00	to 50.00
" " & Sprea. (100 bchs.)	35.00	to 75.00	35.00	to 50.00	35.00	to 50.00	15.00	to 50.00

FLOWERS FOR DECORATION DAY Roses, Carnations, Etc.

ORDER NOW FROM

J. A. BUDLONG WHOLESALE CUT FLOWERS
37-39 RANDOLPH STREET, CHICAGO CROWER OF

Prices quoted in these columns are for Dealers Only. When writing to Advertisers Please Mention HORTICULTURE.

J. B. Murdoch & Co.
Wholesale Florists
FLORISTS' SUPPLIES
714 Penn Ave., PITTSBURG, PA.
Long Distance Phone 1435 Court.

New Crop of Ferns — Decoration Day Stock

FANCY FERNS, \$1.25 PER 1000.

DAGGER FERNS, \$1.00 PER 1000.

Edward A. Beaven

Evergreen, Ala.

FLOWER MARKET REPORTS

BOSTON The pleasant weather of Monday gave quite a boom to the flower trade here, but the unsettled weather of the balance of the week put prices and conditions back to where they have been since Easter. Stock of all kinds is plentiful with but little demand.

BUFFALO The tone of the market was much better the past week as stock shortened in supply, especially carnations the demand brightened up and prices held firm throughout the week. Beauties, Richmonds, Kaiserins, etc., of excellent quality were in good supply and sold more briskly than on weeks previous, but there was too much of the ordinary stock and it was simply carried along. A good cleaning up was looked for on Saturday, but again the rain put a damper on sales. Lily of the valley, sweet peas, jasmine, daisies, mignonette and lilies moved readily. All greens were in good supply.

CHICAGO A week of almost continuous downpour has robbed the cut-flower market of most of the outdoor stock at this time and reduced the supply of carnations to a minimum. Prices have advanced accordingly. Colored carnations are in good demand; white ones move a little slowly. It is certain that colored flowers of all kinds are becoming more and more popular and the demand for white flowers growing steadily less. It looks now as if there might be a decided shortage on carnations for Decoration Day if the weather continues unfavorable, especially as many of the carnation places are off crop. Roses are doing well despite the weather and bringing fair prices. The Baby gladioli are appearing this week, and stock, lily of the valley, marguerites, a few pansies and an occasional vase of lilies give variety to select from. Jessamines are coming into the market by the thousands. A favorable outlook for Decoration Day trade seems to prevail among the Chicago florists.

DETROIT Business has been much better than during the previous week, and towards the week-end supply was actually scarce. A new opening for our product has been created by a local hospital which erected so-called sun parlors and furnished them with large palms, bay trees and hanging baskets.

INDIANAPOLIS Trade conditions the past two weeks have been very slow but there has been no over-stock of anything as the cool, rainy weather has put a decided crimp in the cut of all kinds of flowers. The quality of stock is of the best. Roses and carnations are up to the midwinter average. Lilies are in good supply but in little demand. Sweet peas are the best selling article on the list. The

cool weather has put a damper on outside bedding, there being nothing done in that line up to the present time. A big spring bedding trade is anticipated by the majority of the florists who are well stocked in that line.

NEW YORK The general condition of the market has not made any permanent improvement since last report, although there have been some intermittent periods that seemed to indicate the approach of the end of the inactivity which has continued almost uninterruptedly ever since Easter. The rose market is accentuated by the presence of Brunners and Richmonds of very fine quality in great abundance. Carnations begin to stiffen up a little owing to the departure of the bulb flowers and the approach of Memorial Day. Sweet peas are very fine and hold a position of prominence. Lily of the valley has experienced a decided improvement in demand.

PHILADELPHIA Cool weather and cloudy skies shortened up supplies last week and had much to do with the improved tone of the market. Carnations especially moved better, and towards the end of the week, when the so-called "Mothers' Day" took place, the clean-up in these was the best for the season. The Philadelphia North American is to be credited with this innovation—a white carnation worn by everybody having any respect for their best friend—and it we can now have "Fathers' Day," and some more, the daily press will go far to wipe out many of its most heinous offences against horticulture. Rose market in good, healthy condition. The presence of much mildewed stock of Killarney emphasizes our note of last year in regard to propagating only from outdoor grown stock. Plant no Killarney propagated from indoor stock if you would escape mildew. Lily of the valley supply has eased up a little with demand better. Cattleyas are in good supply with strong demand. A few tree peony blooms are to be seen. The officialis section will be in about the 15th. By the 25th we will have the grand burst of this glorious May beauty here—if the weather proves anything like reasonable.

WASHINGTON While the output of the market is still rather greater than the demand, there is not the stagna-

tion that might be expected at this season. There is still a great demand for decorations and it is to be hoped that business will move smoothly any way till after the commencements next month.

PHILADELPHIA NOTES.

P. T. Demas, Pittsburg Florist' Exchange, was a visitor in Philadelphia.

The club smoker arranged for May 14th had to be called off for lack of interest among the members.

Arthur Niessen, of the Leo Niessen Co., is the orator scheduled for the June meeting of the Florists' Club.

Chas. S. Price, the popular Lansdowne florist, takes his family in a few days to the Pocono mountains for the summer.

Commodore Westcott starts preliminaries at his club house, Waretown, next week, preparatory to the formal opening in June.

Howard M. Earl, manager for W. Atlee Burpee & Co., Philadelphia, will start next week for California on a crop inspection tour.

Herbert H. Johnson, of the Johnson Seed Co., has moved his summer residence to Bala, Pa. There is better golf ground there than in Jersey.

At the regular meeting of the Buffalo Florists' Club on Tuesday last much business of importance was transacted. A paper on orchids was read by one of the members which was heartily received. The committees are working hard, especially the sports and membership committees, the latter having a line on every florist in and around Buffalo.

Watch These Columns

for News of the

CUT FLOWER TRADE

If You Want
Flowers for

MEMORIAL DAY

You will find the most Reliable
Dealers always advertising in

HORTICULTURE

Write to Them.

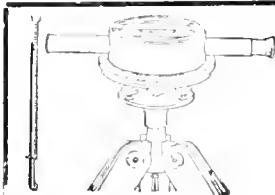

Bostrom Improved Builders' Levels and Farm Levels

For Park, Cemetery and Landscape Gardening use, take the place of expensive Engineering Instruments. Simple in construction, easily adjusted, more substantial and less cumbersome than the more elaborate and complicated instruments. Practical, up-to-date instrument that any one can use. Write for descriptive circulars and be convinced that this Level is necessary to complete your outfit. Builders' Level \$25.00. Farm Level \$12.50.

BOSTROM-GRADY MFG. CO., 139 Madison Avenue., ATLANTA, GA.

JOHN YOUNG
WHOLESALE FLORIST
 Finest American Beauties and Carnations
 31 1/2 West 28 St. - NEW YORK

FORD BROTHERS
 48 West 28th Street, NEW YORK
FINE ROSES FANCY CARNATIONS
 A Full Line of All CUT FLOWERS
 Telephone, 3870 or 3871 Madison Square

H. E. FROMENT,
 Wholesale Commission Florist,
 Choice Cut Flowers,
 57 West 28th St., :: NEW YORK.
 Telephones: 2200, 2201, Madison Square.

The Reliable Commission House
 Richmond Roses and Rich Flowers
 of all varieties
JOS. S. FENRICH
 110 W. 28th Street, New York
 Tel. 324-325 Madison Square

Alfred H. Langjahr
 All choice cut-flowers in season. Send for quotations. Correspondence with shippers of first-class stock invited.
 55 West 28th Street, New York.
 Telephones 4626-4627 Madison Square

JOHN I. RAYNOR
Wholesale Commission Florist SELLING AGENT FOR LARGEST GROWERS
 A full line of Choice Cut Flower stock for all purposes. Comprises every variety grown for New York market, at current prices
 TEL. 1998 MADISON SQUARE 49 W. 28 St., New York City

Walter F. Sheridan
 Wholesale Commission Dealer in
CHOICE CUT FLOWERS
 39 West 28th Street, New York
 Telephone: 3532-3533 Madison Square

HEADQUARTERS FOR NOVELTIES
ORCHIDS A SPECIALTY
 THE HIGHEST GRADE OF **VALLEY** ALWAYS ON HAND
GARDENIAS, DAISIES, ROSES AND CARNATIONS
 Telephone
JAMES McMANUS, 789 Mad. Sq. 42 W. 28th St., New York

PHILIP F. KESSLER 55 & 57 W. 26th St., New York City
 Commission Dealer, Wholesale Buyer and Seller of
 Open from 5 a. m. to 6 p. m. Sunday till 10 a. m.
CUT FLOWERS
 Tel., 5243 and 2921 Madison Sq. Res., 345 J., Newtown.
Finest Lilies in the Market Every Day in the Year.

WHOLESALE COMMISSION FLORIST
J. K. ALLEN 106 W. 28 ST. NEW YORK
 Telephone 167 Madison Sq.
 OPEN 6 A. M. DAILY
 We have a good regular outlet for seasonable flowers

NEW YORK QUOTATIONS PER 100—TO DEALERS ONLY

	Last Half of Week ending May 9 1908	First Half of Week beginning May 11 1908		Last Half of Week ending May 9 1908	First Half of Week beginning May 11 1908
Roses			Cattleyes	20.00 to 40.00	20.00 to 40.00
Am. Beauty, fan and sp.	10.00 to 15.00	10.00 to 15.00	Lilies	2.00 to 4.00	2.00 to 4.00
" extra	6.00 to 8.00	6.00 to 8.00	Lily of the Valley.....	1.00 to 3.00	1.00 to 3.00
" No. 1.....	4.00 to 6.00	4.00 to 6.00	Daisies.....	.25 to 1.00	.25 to 1.00
" Lower grades50 to 2.00	.50 to 2.00	Dafodils	1.00 to 1.50	1.00 to 1.50
Bride, 'Maid, fan and sp	3.00 to 5.00	3.00 to 5.00	Tulips	1.00 to 2.00	1.00 to 2.00
" " extra	1.00 to 3.00	1.00 to 3.00	Mignonette.....	1.00 to 2.00	1.00 to 2.00
" " lwr. grds.....	.50 to 1.00	.50 to 1.00	Gardenias.....	2.00 to 12.00	2.00 to 12.00
Killarney, Richmond, fancy & spec	3.00 to 8.00	3.00 to 8.00	Lilac per bunch15 to .25	.15 to .25
" " lower grades.....	1.00 to 3.00	1.00 to 3.00	Sweet Peas.....	2.00 to 6.00	2.00 to 6.00
Chatenay, Wellesley, fan, and spec	3.00 to 5.00	3.00 to 5.00	Adiantum50 to .75	.50 to .75
" " lower grades.....	.5 to 1.00	.50 to 1.00	Smilax	10.00 to 12.00	10.00 to 12.00
Golden Gate, Ivory.....	.50 to 4.00	.50 to 4.00	Asparagus Plumosus, strings.....	15.00 to 25.00	15.00 to 25.00
Carnations, Fancy and Novelties. .	1.50 to 2.00	1.50 to 2.00	" " & Sprea. (100 bchs.)	15.00 to 25.00	15.00 to 25.00
" " Ordinary50 to 1.00	.50 to 1.00			
Violets to to			

B. S. SLINN, Jr.
 WHOLESALE FLORIST
 55 & 57 W. 26th St., New York City
 Tel., 3864 Madison Sq. Shipping Orders Solicited.
VIOLETS Roses and Carnations

TRAENDLY & SCHENCK
WHOLESALE FLORISTS
 Furnish best stock at fair prices all the year round Send for quotations on fall orders
 Tel. 798-799 Madison Sq. 44 West 28th Street, New York City

Edward C. Horan
Wholesale Florist
 55 WEST 28th ST.
 Tel. 1402 1403 Madison Square New York

Alexander J. Guttman
THE WHOLESALE FLORIST OF NEW YORK
 43 WEST 28th STREET
 PHONES. 1664-1665 MADISON SQUARE
ENOUGH SAID



HARDY CUT FERNS

Sphagnum Moss, Extra Large Bales, per bale, \$1.25. Fancy and Dagger Ferns our specialty. A trial order will convince you that we ship only first-class stock. Headquarters for Florists' supplies and wire work. All cut flowers in season. **BOXWOOD**, per bunch 35c, 50 lbs. \$7.50.

MICHIGAN CUT FLOWER EXCHANGE, INC., All 'phone connections 38-40 Broadway, Detroit, Mich.

FANCY and DAGGER
Extrafine, \$1.75 per 1000. Bronze and Green Galax, \$1.25 per 1000. Leucothoe Sprays, \$1.00 per 100, \$7.50 per 1000.

Headquarters in Western New York
FOR
ROSES, CARNATIONS
And all kinds of Seasonable Flowers
Wm. F. Kasting Co.
Wholesale Commission Florist, also Dealer in
Florists' Supplies and Wire Designs.
383-87 ELLICOTT ST.
BUFFALO, N. Y.
Give us a trial. We can please you.

FRANK S. HICKS & CO.
Wholesale Florists.
Open Now for Consignments of Cut Flowers.
39 West 28th Street, - New York City
Tel. 2920 Mad. Sq.

ROBERT J. DYSART,
Public Accountant and Auditor
Simple methods of correct accounting
especially adapted for florists' use.
Books Balanced and Adjusted
Merchants Bank Building
28 STATE ST., - BOSTON
Telephone, Main 38

HENRY M. ROBINSON & CO.
Wholesale and Commission
FLORISTS
Hardy Cut Evergreens and Florists' Supplies
15 Province St. and 9 Chapman Place,
BOSTON, MASS.

Flowers and
Florists' Supplies
The best place in AMERICA to buy
BAY TREES
N. F. McCarthy & Co.
84 Hawley St., BOSTON, MASS.
Largest Dealers in Supplies in New England.

WHOLESALE FLOWER MARKETS. — PER 100. TO DEALERS ONLY.

	CINCINNATI May 13	DETROIT May 13	BUFFALO May 13	PITTSBURG May 13
ROSES				
Am. Beauty, Fan, and Sp.....	25.00 to 35.00	20.00 to 25.00	15.00 to 20.00	20.00 to 25.00
“ Extra	15.00 to 20.00	12.00 to 15.00	12.00 to 15.00	12.50 to 15.00
“ No. 1	8.00 to 12.00	6.00 to 12.00	6.00 to 12.00	6.00 to 10.00
“ Lower grades.....	4.00 to 6.00	2.00 to 4.00	2.00 to 6.00	3.00 to 4.00
Bride, 'Maid, F. & S.....	4.00 to 6.00	6.00 to 8.00	6.00 to 7.00	6.00 to 8.00
“ Extra to 3.00	4.00 to 6.00	5.00 to 6.00 to 5.00
“ Low. gr..... to 2.00	2.00 to 3.00	3.00 to 5.00	3.00 to 4.00
Killarney, Richmond, Fan, & Sp.....	6.00 to 8.00	6.00 to 8.00	6.00 to 7.00	6.00 to 8.00
“ Lower grades.....	3.00 to 4.00	2.00 to 3.00	3.00 to 6.00	4.00 to 6.00
Chatenay, Wellesley, Fan, & Sp.....	6.00 to 8.00	6.00 to 8.00	6.00 to 7.00	6.00 to 8.00
“ Lower grades.....	3.00 to 4.00	2.00 to 3.00	3.00 to 6.00	4.00 to 6.00
Golden Gate, Ivory.....	4.00 to 6.00 to 6.00	3.00 to 5.00	4.00 to 6.00
CARNATIONS				
Fancy and Novelties..... to 3.00	2.00 to 3.00	2.00 to 2.50	2.00 to 3.00
Ordinary	1.50 to 2.00	1.00 to 2.00 to	1.00 to 1.50
MISCELLANEOUS				
Violets to .50	.50 to .75 to to .25
Cattleyas to 75.00	50.00 to 60.00	60.00 to 75.00	50.00 to 75.00
Cypripediums to to to to
Lilies	6.00 to 8.00	6.00 to 8.00	8.00 to 12.00	4.00 to 8.00
Lily of the Valley.....	3.00 to 4.00	2.00 to 3.00	3.00 to 4.00	3.00 to 4.00
Daisies.....	1.00 to 1.50	.50 to 1.00	1.00 to 2.00	1.00 to 1.50
Daffodils.....	1.00 to 2.00 to 3.00	1.00 to 2.00	1.00 to 2.00
Tulips..... to 2.00	2.00 to 4.00	1.00 to 2.00	1.00 to 2.00
Mignonette.....	2.00 to 3.00	4.00 to 6.00	1.00 to 3.00	2.00 to 3.00
Gardenias..... to	20.00 to 35.00	2.00 to 3.00 to 2.00
Lilac per bunch.....	1.50 to 2.00	1.00 to 1.50	1.50 to 2.00 to 15.00
Sweet Peas.....	.50 to .75	2.00 to 3.00	.40 to .75	.20 to .50
Adiantum..... to 1.25 to 1.00	.50 to 1.00	1.25 to 1.50
Whitman's Fronds..... to to	8.00 to 10.00 to
Smilax..... to 15.00	12.00 to 15.00	12.00 to 15.00	12.00 to 15.00
Asparagus Plumosus, strigs.....	30.00 to 50.00	35.00 to 50.00	50.00 to 60.00	35.00 to 50.00
“ & Sprea (100 bchs.).....	35.00 to 50.00	35.00 to 50.00	35.00 to 50.00	30.00 to 50.00

SAMUEL A. WOODROW
WHOLESALE PLANTSMAN
Palms, Large and Small Ferns, etc.
53 West 30th Street, NEW YORK
Telephone 2083 Madison

WILLIAM H. KUEBLER
Brooklyn's Foremost and Best
WHOLESALE COMMISSION HOUSE
A First Class Market for all CUT FLOWERS
28 Willoughby St., Brooklyn, N. Y.
Tel. 4591 Main

CLEARY'S HORTICULTURAL CO.
Management AMBROSE T. CLEARY
Wholesale Contracting, Jobbing, Auction
HORTICULTURAL PRODUCTS
of every description.
Consignments Received. Surplus Stock Converted.
62 Vesey St., NEW YORK

Moore, Hentz & Nash,
Wholesale Commission Florists,
55 and 57 West 26th Street,
Telephone No. 756
Madison Square. **New York.**

H. C. BERNING
Wholesale Florist
1402 Pine Street, ST. LOUIS, MO.

MILLANG BROS.
WHOLESALE COMMISSION FLORISTS
41 West 28th Street
Telephones 3860 Madison
3561 **NEW YORK**

A. MOLTZ
Will purchase flowers on order in
N. Y. market and ship carefully at
prevailing wholesale prices. Address
55-57 West 26th Street, New York City

REED & KELLER
122 West 25th St., New York
Florists' Supplies
We manufacture all our
Metal Designs, Baskets, Wire Work & Novelties
and are dealers in
Glassware Decorative Greens and Florists' Requisites.

In writing to Advertisers kindly mention Horticulture

Buyer's Directory and Ready Reference Guide

Advertisements under this head, one cent a word. Initials count as words.

Regular advertisers in this issue are also listed under this classification without charge. Reference to List of Advertisers will indicate the respective pages.

Buyers falling to find what they want in this list will confer a favor by writing us and we will try to put them in communication with reliable dealers.

ACCOUNTANT

R. J. Dysart, 28 State St., Boston.
For page see List of Advertisers.

ALTERNANTHERAS

Red Alternantheras at 40 cents per 100.
C. W. Moeckel, 17 Summer St., Fitchburg, Mass.

AQUATIC PLANTS

Aquarium plants the year round. Wholesale and retail. Send for price list.
Schmid's Emporium of Pets, 712 12th Street, Washington, D. C.

Water Lilies, Nymphaea Odorata Rosen, \$2.00 per doz. W. I. Bodfish, West Barnstable, Mass.

ARAUCARIAS

A. Leuthy & Co., Perkins St. Nurseries, Roslindale, Mass.

For page see List of Advertisers.

John McKenzie, North Cambridge, Mass.
For page see List of Advertisers.

ASPARAGUS

A. N. Pierson, Cromwell, Conn.
Asparagus Plumosus Seedlings.
For page see List of Advertisers.

J. M. Thornburn & Co., 33 Barclay St., New York.

Plumosus Nanus and P. Robustus.
For page see List of Advertisers.

Asparagus plumosus ad Sprengerl, 2-in., strong, \$2.25 per 100. J. H. Dunn & Son, Westfield, N. Y.

150 Asparagus plumosus nanus, 2½-in., extra fine, 3c; 300 Pteris Onwardi, 2½-in., 2c; heliotropes, 2 in., 2c; dahlia roots, best varieties, \$2.00 per 100; mixed, \$1.50. Edwin Bishop, Roslyn, Md.

Asparagus Plumosa, 2 in. pots. Fine plants, \$3.00 per 100; \$25.00 per 1000. Cash with order or good reference. Erie Floral Co., Erie, Pa.; or, Wm. F. Kasting Co., 385 Ellicott St., Buffalo, N. Y.

ASTER SEED

Altimo Culture Co., Canfield, O.
For page see List of Advertisers.

AUCTION SALES

Cleary's Horticultural Co., 62 Vesey St., New York.

For page see List of Advertisers.

Wm. Elliott & Sons, 42 Vesey St., New York.
For page see List of Advertisers.

AZALEAS

A. Leuthy & Co., Perkins St. Nurseries, Roslindale, Mass.

For page see List of Advertisers.

August Rolker & Sons, New York, 31 Barclay St., or P. O. Box 752.

For page see List of Advertisers.

BAMBOO CANES

Stumpp & Walter Co., 50 Barclay St., New York.

For page see List of Advertisers.

Yokohama Nursery Co., 31 Barclay Street, New York.

For page see List of Advertisers.

BAY TREES.

N. F. McCarthy & Co., 84 Hawley St., Boston.

For page see List of Advertisers.

Bay Trees and Box Trees, standards and pyramids. All sizes. Price list on application. J. Roehrs Co., Rutherford, N. J.

BEDDING PLANTS

R. Vincent, Jr., & Sons Co., White Marsh, Maryland.

For page see List of Advertisers.

BEDDING PLANTS - Continued

A. N. Pierson, Cromwell, Conn.
For page see List of Advertisers.
40,000 geraniums, 10 best standard sorts; 5000 Vinca variegata; Salvia; heliotrope, dark; feverfew, double white. Good stock, prices right. E. D. Kaulback & Son, Malden, Mass.

A. Leuthy & Co., Perkins St. Nurseries, Roslindale, Mass.

For page see List of Advertisers.

Geraniums in 3 1/2 in. pots, S. A. Nutt, Inc. Doyle, Frances Perkins, Beatha de Presilly, Beante Polytvine, Double White, Castellano, \$7 per 100, shipped in paper pots. Marie Sallerol, 2 1/2 in. pots, \$3 per 100. Compacta and Gracilis Lobelia, \$3 per 100. Golden Feather, \$2. Marguerite Carnations, \$3. Centaurea, Gymnocarpa, \$3. J. B. Shurtleff & Son, Cushman Ave., Revere, Mass.

Bargains in pot grown plants, in variety, ready for market at once. Send for prices. It will pay you. Alonzo J. Bryan, Washington, New Jersey.

BEGONIAS

Thomas Roland, Nahant, Mass.
Gloire De Lorraine.

For page see List of Advertisers.

Begonia "Agatha" (Veitch) (Improvement on Beg. Gloire de Lorraine) an easier grower, earlier flowering and of a more pleasing shade of soft, satiny pink; strong young plants from leaf cuttings, now ready; \$18.00 per 100.

Begonia "Gloire de Lorraine", strong, young plants from leaf cuttings, ready for delivery early in June; \$15.00 per 100; \$110.00 per 1000.

J. A. Peterson,

Melheary Ave., Westwood, Cincinnati, O.

BERBERIS THUNBERGII

Oak Hill Nurseries, Roslindale, Mass.
For page see List of Advertisers.

BOILERS

BOILERS. "Burnham" Boilers made for greenhouse heating. Lord & Burnham, 1133 Broadway, N. Y.

Kroeschell Bros. Co., 35 Erie St., Chicago.
For page see List of Advertisers.

BOXWOOD

Boxwood, heavy bushes, 18 to 24 in. 75c; 24 to 30 in. \$1.25; 36 in. \$1.75; Pyramids, 30 to 36 in. \$1.50; 36 to 42 in. \$2.00. Wagner Park Conservatories, Sidney, O.

BUILDERS' AND FARM LEVELS

Bostrom-Brady Mfg. Co., 159 Madison Ave., Atlanta, Ga.

For page see List of Advertisers.

BUILDING MATERIAL

BUILDING MATERIAL of all description for All Cypress, Semi-Iron, Iron Frame or Truss Houses. Hot Red Sash and Frames. Lord & Burnham Co., 1133 Broadway, N. Y.

BULBS AND TUBERS

Joseph Breck & Sons, 47-54 N. Market St., Boston.

For page see List of Advertisers.

J. M. Thornburn & Co., 33 Barclay St., New York.

For page see List of Advertisers.

A. T. Boddington, 342 W. 14th St., N. Y. Cold Storage Lilies.

For page see List of Advertisers.

Rickards Bros., 37 East 19th St., New York.
For page see List of Advertisers.

BULBS AND TUBERS - Continued

H. F. Mitchell Co., Philadelphia.
For page see List of Advertisers.

H. E. Fiske Seed Co., Faneuil Hall Sq., Boston.

For page see List of Advertisers.

James Vlek's Sons, Rochester, N. Y. Fall Bulbs.

For page see List of Advertisers.

Aug. Rolker & Sons, 31 Barclay St., New York.

Seasonable Import Plants and Bulbs.

For page see List of Advertisers.

K. Veithuys, Hillegom, Holland, Represented by Felix Bosch, 260 Clarendon St., Boston.

Bulbs French and Dutch.

For page see List of Advertisers.

Ralph M. Ward & Co., 2 W. Broadway, New York, Agts. for Marital Bremond, Ollioules, France.

French Bulbs.

W. J. Eldering & Son, Overveen, Haarlem, Holland.

High Grade Dutch Bulbs.

For page see List of Advertisers.

A. Mitting, 17-23 Kennan St., Santa Cruz, California.

Calla Bulbs.

For page see List of Advertisers.

CANNAS

The Conard & Jones Co., West Grove, Pa.
For page see List of Advertisers.

Started Cannas from sand, \$2; from pots, \$5. J. B. Shurtleff & Son, Cushman Ave., Revere, Mass.

CAPE JASMINE BUDS

Chas. Ehlers, Houston, Texas.
For page see List of Advertisers.

CARNATIONS

F. Dorner & Sons Co., Lafayette, Ind.
For page see List of Advertisers.

S. S. Skidelsky, 1741 N. 18th St., Philadelphia.

Chicago Carnation Co., Joliet, Ill.

For page see List of Advertisers.

John E. Haines, Bethlehem, Pa. Carnations Imperial and Pink Imperial.

For page see List of Advertisers.

A. N. Pierson, Cromwell, Conn.

For page see List of Advertisers.

H. F. Littlefield, 552 Main St., Worcester, Mass.

For page see List of Advertisers.

Albert Roper, Tewksbury, Mass. Carnation Bay State.

For page see List of Advertisers.

Carnation cuttings of all the leading varieties at the same price as any reliable firm. Write for prices before you look elsewhere. Wm. F. Kasting Co., 385 Ellicott St., Buffalo, N. Y.

CARNATIONS! FIELD GROWN!!

15,000 Enchantress and Winsor, ready for delivery July 1st. Orders filled in strict rotation. Order now and be first! Prices on application. We guarantee satisfaction. We lead in superb field grown stock.

WANOKA GREENHOUSES, Barneveld, N. Y.

Columbia Carnation Co., New London, Ct.
For page see List of Advertisers.

For List of Advertisers See Page 677

CAULIFLOWER AND CABBAGE SEED

H. Hartmann & Co., Copenhagen, Denmark.
For page see List of Advertisers.

CHRYSANTHEMUMS

Chas. H. Totty, Madison, N. J. Special Offer.
For page see List of Advertisers.

A. N. Pierson, Cromwell, Conn.
For page see List of Advertisers.

Wm. W. Edgar Co., Waverley, Mass.
For page see List of Advertisers.

H. F. Littlefield, 552 Main St., Worcester, Mass.
Rooted Cuttings.
For page see List of Advertisers.

H. L. Cameron, No. Cambridge, Mass.
For page see List of Advertisers.

Chrysanthemum rooted cuttings, best varieties; write for list and prices. Edwin Bishop, Roslyn, Md.

Chrysanthemums—Christmas, Polly Rose, Pacific, Halliday, Nonin and others, \$1.25 per 100. F. P. Sawyer, 125 High St., Clinton, Mass.

Have 100,000 fine young well-rooted 'Mums, cuttings of the best 60 commercial varieties. Send for our new and low price list. Satisfaction guaranteed. Wm. Ehmann, Jr., Corfn, N. Y.

Chrysanthemums ready: 2 1/2 inch strong stock of Touset, Oct. Frost, Polly Rose, Wanamaker, and all standards, \$2 per 100, \$18 per M. New: 2 1/2, strong, Alice Roosevelt, Hankey, Clay Frick, Winter Cheer, Rosette, B. May, \$4 per 100, \$30 per M. Cash. Send for catalog. Harlowarden Greenhouses, Greenport, N. Y.

Chrysanthemums. Fine, strong, 2 and 2 1/2 in. pot plants of Monrovia, October Frost, Rosiere, Touset, Alice Byron, Dr. Enguehard, \$3.00 per 100; \$25.00 per 1000. Cash or C. O. D. Gunnar Teilmann, Marion, Ind.

COLEUS

A. N. Pierson, Cromwell, Conn.
For page see List of Advertisers.

Coleus, Golden Bedder, Verschaffeltii, and mixed Coleus, rooted cuttings, 60c per 100; \$5.00 per 1000. Cash with order. J. E. Felthousen, Florist, Schenectady, N. Y.

CONIFERS

John Waterer & Sons, Ltd., American Nursery, Bagshot, Eng.
For page see List of Advertisers.

CUT FLOWER BOXES.

Edwards Folding Box Co., Philadelphia.
For page see List of Advertisers.

Folding cut flower boxes, the best made Write for list. Holton & Hunkel Co., Milwaukee, Wis.

DAHLIAS

David Herbert & Son, Atco, N. J.
For page see List of Advertisers.

R. Vincent, Jr. & Sons Co., White Marsh, Maryland.
For page see List of Advertisers.

Dahlias, balance of season, 25 named varieties, postpaid, \$1.00. Catalogue free. J. L. Moore, Northboro, Mass.

Dahlias: About 2000 Cath. Duer, Kriemhilde, Brunhilde, Snowclad, etc., \$3 per 100. Cash. Harlowarden Greenhouses, Greenport, N. Y.

Dahlias. Novelties and standard varieties, true to name, a choice list of the best introductions. Send for catalogue of dahlias, hollyhocks, hardy plants, etc. W. W. Wilmore, Box 382, Denver, Colo.

Cactus, Decorative. Show, Fancy and Pompon Dahlias. 75 leading varieties to select from. Strong divided clumps, in 10 or 20 varieties, my selection at \$3.00 per 100; \$25.00 per 1000. Single Dahlias, mixed, \$1.00 per 100. Cash with order please. Hermann Thelemann, Monson, Mass.

Dahlias. Black Beauty, fine, dark red, \$2.50 per 100; undivided clumps, mixed, \$3.00. Wagner Park Conservatories, Sidney O.

DECORATIVE PLANTS

A. Leuthy & Co., Perkins St. Nurseries, Roslindale, Mass.
For page see List of Advertisers.

DRACAENAS

Dracaena indivisa, 2 1/2 in., strong seedlings, \$2.00 per 100. Jos. Labo, Joliet, Ill.

ECHEVERIAS

Echeverias, \$18 per 1000, post paid. McDowell, Mexico City.

ELECTRIC CIRCULATOR

The Castle Co., 170 Summer St., Boston.
For page see List of Advertisers.

FERNS

A. Leuthy & Co., Roslindale, Mass.
For page see List of Advertisers.

H. H. Barrows & Son, Whitman, Mass. Nephrolepis Whitmanii.
For page see List of Advertisers.

John Scott, Brooklyn, N. Y.
For page see List of Advertisers.

FRENS FOR DECORATION DAY

E. A. Beaven, Evergreen, Ala.
For page see List of Advertisers.

FERTILIZERS

Pulverized Manure Co., 31 Union Stock Yards, Chicago, Ill.

Wizard Brand Cattle Manure.
For page see List of Advertisers.

Thos. J. Grey & Co., 32 and 33 South Market St., Boaton. High-Grade Scotch Soot.
For page see List of Advertisers.

FLORAL PHOTOGRAPHS

Floral Photographs. Foley's 226-228 1-2 Bowery, New York.

FLORISTS' LETTERS.

Boston Florist Letter Co., 66 Pearl St., Boston, Mass.
For page see List of Advertisers.

Koral Mfg. Co., 26 Hawley St., Boston.
For page see List of Advertisers.

FLORISTS SUPPLIES

N. F. McCarthy & Co., 84 Hawley St., Boston.
For page see List of Advertisers.

H. M. Robinson & Co., 15 Province St. and 9 Chapman Pl., Boston, Mass.
For page see List of Advertisers.

Keed & Keller, 122 W. 25th St., New York.
For page see List of Advertisers.

J. B. Murdoch & Co., 714 Penn Ave., Pittsburg, Pa.
For page see List of Advertisers.

H. Bayersdorfer & Co., 1129 Arch St., Philadelphia.
For page see List of Advertisers.

Alex. Mann, Jr., Co., 1125 Polk St., San Francisco, Calif.

FLOWERS BY TELEGRAPH

Park Floral Co., Denver, Colo.
For page see List of Advertisers.

J. N. Champton & Co., 1026 Chapel St., New Haven, Conn.
For page see List of Advertisers.

George H. Cooke, Washington, D. C.
For page see List of Advertisers.

Guda Bros. Co., 1214 F St., Washington, D. C.
For page see List of Advertisers.

Atlanta Floral Co., Atlanta, Ga.
For page see List of Advertisers.

M. C. & J. E. Hanswirth, 232 Michigan Ave., Chicago.
For page see List of Advertisers.

William J. Smyth, Michigan Ave. and 31st St., Chicago.
For page see List of Advertisers.

George Withhold Co., 1657-59 Buckingham Place, Chicago.
For page see List of Advertisers.

Jacob Schulz, 644 4th Ave., Louisville, Ky.
For page see List of Advertisers.

Thos. F. Galvin, 124 Tremont St., Boston.
For page see List of Advertisers.

Julius A. Zinn, 2 Beacon St., Boston.
For page see List of Advertisers.

FLOWERS BY TELEGRAPH — Continued

Houghton & Clark, 396 Boylston St., Boaton.
For page see List of Advertisers.

Sidney Hoffman, 59-61 Massachusetts Ave., Boston.
For page see List of Advertisers.

Edward MacMullin, 194 Boylston St., Boston.
For page see List of Advertisers.

J. Breitmeyer's Sons, Miami and Gratiot Aves., Detroit, Mich.
For page see List of Advertisers.

Samuel Murray, 1017 Broadway, Kansas City, Mo.
For page see List of Advertisers.

Wm. L. Rock Flower Co., 1116 Walnut St., Kansas City, Mo.
For page see List of Advertisers.

Fred C. Weber, 4326-23 Olive St., St. Louis, Mo.
For page see List of Advertisers.

H. G. Eyrea, 11 N. Pearl St., Albany, N. Y.
For page see List of Advertisers.

David Clarke's Sons, 2159-2141 Broadway, New York.
For page see List of Advertisers.

W. H. Donohoe, 17 E. 23th St., New York.
For page see List of Advertisers.

Alex. McConnell, New York.
For page see List of Advertisers.

M. A. Bove, 1294 Broadway, New York.
For page see List of Advertisers.

Robert G. Wilson, Fulton St. & Greene Av., Brooklyn, N. Y.
For page see List of Advertisers.

Thomas Young, Jr., 500 Fifth Ave., N. Y.
For page see List of Advertisers.

Young & Nugent, 42 W. 28th St., N. Y.
For page see List of Advertisers.

J. H. Dunlop, 96 Yonge St., Toronto, Can.
For page see List of Advertisers.

FLOWER POTS

W. H. Ernest, 28th and M Sts., Washington, D. C.
For page see List of Advertisers.

A. H. Hews & Co., Cambridge, Mass.
For page see List of Advertisers.

Hilfinger Bros., Ft. Edward, N. Y.
For page see List of Advertisers.

Red pots, seed pans, etc. The Peters & Reed Pottery Co., Zanesville, O.

FORESTRY AND ORNAMENTAL PLANTING

Jackson's Nurseries, Portland, Me.
For page see List of Advertisers.

FOXGLOVES

Foxglove in 3 colors, \$5.00 per 100. J. B. Shurtleff & Son, Cushman Ave., Revere, Mass.

GALAX

Michigan Cut Flower Co., 38 and 40 Broadway, Detroit, Mich.
For page see List of Advertisers.

GARDEN VASES

Kramer Bros. Foundry Co., Dayton, O.

GERANIUMS

R. Vincent Jr. & Sons Co., White Marsh, Md.
New and Standard Varieties.
For page see List of Advertisers.

Wm. W. Edgar Co., Waverley, Mass.
For page see List of Advertisers.

Geraniums, 2-in., double red, \$1.50 per 100. J. H. Dann & Son, Westfield, N. Y.

H. L. Cameron, No. Cambridge, Mass.
For page see List of Advertisers.

I have a lot of good 4 in. Geraniums in the following varieties about 20,000 in all: Nutt, La. Pilot, Flora Hill, Buchner, Mme. Salleron and a few others at from \$7.00 to \$10.00 per 100. Also Alternantheras, mostly red, at \$2.00 per 100; Coleus at \$2.50 per 100; and a few other varieties in plants. Hermann Schoenfeld, 86th and Crothers Ave., Elmwood, Philadelphia, Pa.

In writing to Advertisers kindly mention Horticulture

GERANIUMS Continued

30,000 geraniums, 15 varieties. Fine stock, very branching, full of bud and bloom. Any variety or mixed colors, double or single. \$7.00 per 100. Alonzo J. Bryan, Washington, New Jersey.

GLADIOLI

Gladiolus, large flowering mixed, balance of season, \$1.00 per 100; postpaid. J. L. Moore, Northboro, Mass.

Gladioli, choice mixed, 65c. per 100. W. L. Rodfish, West Barnstable, Mass.

GLASS

Boston Plate & Window Glass Co., Boston. For page see List of Advertisers.

Standard Plate Glass Co., 26-30 Sudbury St., Boston.

For page see List of Advertisers.

S. Jacobs & Sons, 1365-79 Flushing Ave., Brooklyn, N. Y.

For page see List of Advertisers.

Metropolitan Material Co., 1398-1408 Metropolitan Ave., Brooklyn, N. Y.

Foley Mfg. Co., Western Ave., between 25th & 26th Sts., Chicago.

Greenhouse glass, lowest prices. Johnston Glass Co., Hartford City, Ind.

GLASS, High Grade, Double Thick Greenhouse Glass. Lord & Burnham, 1133 Broadway, N. Y.

GLAZING POINT

H. A. Dreer, Philadelphia, Pa. For page see List of Advertisers.

GLAZING POINTS, Lord & Burnham Special Glazing Nails (Points). Lord & Burnham, 1133 Broadway, N. Y.

GRANDIFLORA CAPE JESSAMINE BUDS

C. W. Benson, Alvin, Texas.

GREENHOUSE BUILDING MATERIAL

Lord & Burnham Co., 1133 Broadway, New York.

For page see List of Advertisers.

Pierson U-Bar Co., 1 Madison Sq., N. Y. For page see List of Advertisers.

A. T. Stearns Lumber Co., Neponset, Boston.

For page see List of Advertisers.

King Construction Co., N. Tonawanda, New York.

For page see List of Advertisers.

J. C. Moninger Co., 117 East Blackhawk St., Chicago, Ill.

For page see List of Advertisers.

Foley Mfg. Co., Western Ave., between 25th & 26th Sts., Chicago.

For page see List of Advertisers.

I. Cassidy, Summer Ave. and Erie R. R., Newark, N. J.

For page see List of Advertisers.

Geo. R. Doane, 18 Midway St., Boston. Iron Pipe.

For page see List of Advertisers.

S. Jacobs & Sons, 1365-79 Flushing Ave., Brooklyn, N. Y.

For page see List of Advertisers.

Metropolitan Material Co., 1398-1408 Metropolitan Ave., Brooklyn, N. Y.

GREENHOUSE CONSTRUCTION

GREENHOUSE CONSTRUCTION, Semi Iron Greenhouse, New Truss Houses and Iron Frame Houses. Lord & Burnham, 1133 Broadway, N. Y.

J. A. Payne, 260-274 Culver Ave., Jersey City, N. J.

For page see List of Advertisers.

I. Cassidy, Summer Ave. and Erie R. R., Newark, N. J.

For page see List of Advertisers.

Foley Mfg. Co., Western Ave., between 25th & 26th Sts., Chicago.

For page see List of Advertisers.

GUTTERS

GUTTERS, Cast Iron Gutters, L. & B. Improved V Shaped Gutter with drip gutter attachment. Lord & Burnham, 1133 Broadway, N. Y.

HAIL INSURANCE

Florists' Hall Assn. of America. J. G. Ester, Saddle River, N. J. For page see List of Advertisers.

HARDY FERNS AND SUPPLIES

H. M. Robinson & Co., 15 Province St. and 9 Chapin Pl., Boston, Mass. For page see List of Advertisers.

Michigan Cut Flower Exchange, 38 and 40 Broadway, Detroit, Mich. Fancy Ferns.

For page see List of Advertisers.

HART'S HANDY HANDLE

Geo. B. Hart, 24 Stone St., Rochester, N. Y. For page see List of Advertisers.

HEATING APPARATUS

Lord & Burnham Co., 1133 Broadway, New York. For page see List of Advertisers.

Pierson U-Bar Co., 1 Madison Sq., N. Y. For page see List of Advertisers.

John A. Payne, 260-274 Culver Ave., Jersey City, N. J. For page see List of Advertisers.

HEDGE PLANTS

Peter's Nursery, Knoxville, Tenn. For page see List of Advertisers.

HELIOTROPES.

Heliotropes, 2-in., 2c.; rooted cuttings, from soil, 75c. per 100. Edwin Bishop, Roslyn, Md.

HELP FURNISHED

Thos. H. Bambrick, 34 S. 7th St., Phila. For page see List of Advertisers.

HERBACEOUS PERENNIALS

Ray State Nurseries, No. Abington, Mass. For page see List of Advertisers.

New England Nurseries, Inc., Bedford, Mass.

For page see List of Advertisers.

P. Ouwkerk, P. O. No. 2, Hoboken, N. J. For page see List of Advertisers.

HOLLYHOCKS

Hollyhocks, separate colors, field grown, healthy stock, \$3.00 per 100; also Pablas, novelties and standard varieties. Send for catalogue. W. W. Willmore, Box 382, Denver, Colo.

Field grown double Hollyhocks in separate colors, \$7. J. B. Shurtleff & Son, Cushman Ave., Revere, Mass.

HOT-BED SASH

The A. T. Stearns Lumber Co., Neponset, Mass.

For page see List of Advertisers.

Pierson U-Bar Co., 1 Madison Sq., N. Y. For page see List of Advertisers.

Lord & Burnham Co., 1133 Broadway, N. Y. For page see List of Advertisers.

Foley Mfg. Co., Western Ave., between 25th & 26th Sts., Chicago.

HYDRANGEAS.

W. W. Edgar Co., Waverley, Mass. For page see List of Advertisers.

INSECTICIDES.

Nicotinide kills all greenhouse pests. P. R. Palethorpe Co., Eleventh St., Owensboro, Ky. For page see List of Advertisers.

IRISES

J. M. Thorburn & Co., 33 Barclay St., New York.

For page see List of Advertisers.

JAPANESE PLANTS

Yokohama Nursery Co., 31 Barclay St., New York.

For page see List of Advertisers.

JUMPING BEANS

Jumping Beans, \$5 per 1000, post paid. McDowell, Mexico City.

KENTIAS

A. Leuthy & Co., Roslindale, Mass. For page see List of Advertisers.

LAWN VASES

Kramer Bros. Edy. Co., Dayton, Ohio.

LILIES

W. W. Edgar Co., Waverley, Mass. For page see List of Advertisers.

LOBELIAS

Double Lobelia, Kathleen Mallard, 3 in., Sc.; 2 1/4 in., 4c., full of buds and bloom; strong cuttings from soil, 2c. Mme. Saleroi geraniums, 2 1/2 in., 2 1/2c. Reduced prices; 1 need room. J. L. Stone, Trumansburg, N. Y.

MASTICA

F. O. Pierce Co., 12 W. Broadway, New York. For page see List of Advertisers.

MOON VINES

Godfrey Aschmann, 1012 W. Ontario St., Philadelphia.

For page see List of Advertisers.

Moon vines, fine strong plants, 3 in., \$4.00 per 100. Edwin Bishop, Roslyn, Md.

MYRTLE

Myrtle for cemetery planting, strong field grown clumps, \$2.00 per 100, or \$17.50 per 1000. Geo. A. Dhanan, East Walnut Hills, Cincinnati, O.

NEW AND RARE PLANTS

Rose Hill Nurseries, New Rochelle, N. Y. For page see List of Advertisers.

NICO-FUME

Kentucky Tobacco Product Co., Louisville, Ky.

NURSERY STOCK

John Waterer & Sons, Ltd., American Nursery, Bagshot, England. For page see List of Advertisers.

New England Nurseries, Bedford, Mass. Shrubs, Roses and Herbaceous Perennials. Specimen Pyramidal Box.

For page see List of Advertisers.

Ray State Nurseries, N. Abington, Mass. Herbaceous Perennials, Hardy Ornamental Trees.

For page see List of Advertisers.

Cleary's Horticultural Co., 62 Veasey St., New York.

For page see List of Advertisers.

P. Ouwkerk, 216 Jane St., Weehawken Heights, N. J.

Holland Nursery Stock for Forcing. For page see List of Advertisers.

American Nursery Co., 150 Broadway, New York, N. Y.

For page see List of Advertisers.

Peter's Nursery Co., Knoxville, Tenn. Live Fences; Amoor and California Privet. For page see List of Advertisers.

ORCHID PLANTS

Lager & Hurrell, Summit, N. J. For page see List of Advertisers.

Sander, St. Albans, England. Importers, Exporters, Growers, Hybridists. For page see List of Advertisers.

Julius Roehrs Co., Rutherford, N. J. For page see List of Advertisers.

Carrillo & Baldwin, Secaucus, N. J. For page see List of Advertisers.

Joe. A. Manda, 191 Valley Road, W. Orange, N. J.

For page see List of Advertisers.

Ordonez Bros., Madison, N. J., Box 106. For page see List of Advertisers.

PALMS

A. Leuthy & Co., Perklna St. Nurseries, Roslindale, Mass.

For page see List of Advertisers.

Robert Craig Co., Market and 49th Sts., Philadelphia, Pa.

For page see List of Advertisers.

August Rolker & Sons, 31 Barclay St., New York.

For page see List of Advertisers.

Kentia, Phoenix, etc., all sizes. Write for new price list. Julius Roehrs Co., Rutherford, N. J.

Palms, Lantana, 8 in. \$1.75; 10 in. \$2.50; Phoenix, 7 in. 36 in. high, \$1.50; 8 in. \$2.50. Wagner Park Conservatories, Sidney, O.

PAINT AND PUTTY

PAINT AND PUTTY: Ideal Greenhouse and Special Greenhouse Putty. Lord & Burnham, 1133 Broadway, N. Y.

For List of Advertisers See Page 677

PANSIES

I. E. Coburn, 291 Ferry St., Everett, Mass.
For page see List of Advertisers.

PATENTS

Siggers & Siggers, Washington, D. C.
For page see List of Advertisers.

PEAT

Orchid peat, Rotted peat, Azalea peat, Leaf-Mould, Live Sphagnum moss, Baled Sphagnum moss, Green Clump moss, etc. Jobbers' list on application. C. W. Brownell & Co., Walden, N. Y.

PELARGONIUMS

R. Vincent, Jr. & Sons Co., White Marsh, Maryland.
For page see List of Advertisers.

PEONIES

Wholesale Peony list for fall 1908 is now ready. J. F. Rosenfield, West Point, Neb.
One of the finest collections in America. Send 25 cts. in stamps for new edition of Peony Manual. C. S. Harrison's Select Nursery, York, Neb.

PHLOXES

Send 25 cts. in stamps for Phlox Manual. Fine mixed phloxes \$1.50 per 100. C. S. Harrison's Select Nursery, York, Neb.

PIPE AND FITTINGS

Foley Mfg. Co., between Western Ave. and 26th St., Chicago, Ill.

PIPE AND FITTINGS. Cast Iron and Wrought Pipe, Valves, Elbows, Pipe Hooks, Automatic Air Headers, etc. Lord & Burnham, 1133 Broadway, N. Y.

PLANT STAKES AND TRELLISES

Seele's Patent, for roses, chrysanthemums, gladioli, tuberoses, dahlias, tomatoes, egg plants, etc. H. D. Seele & Sons, Manuf., Elkhart, Ind.

POT HANGERS

Pot hangers, Kramer's \$1 doz. by exp. \$1.25 by mail. I. N. Kramer & Son, Cedar Rapids, Ia.

PRIMULA SEED

H. E. Fiske Seed Co., 13 Fanenil Hall Sq., Boston.

For page see List of Advertisers.

O. V. Zangen, Hoboken, N. J.
For page see List of Advertisers.

RAFFIA

Raffia (colored), 20 beautiful shades. Samples free. R. H. Comey Co., Camden, N. J.; 810 Washburn Ave., Chicago, Ill.

RETAIL FLORISTS

Park Floral Co., Denver, Colo.
For page see List of Advertisers

George H. Cooke, Washington, D. C.
For page see List of Advertisers.

Gude Bros. Co., 1214 F St., Washington, D. C.
For page see List of Advertisers

Atlanta Floral Co., Atlanta, Ga.
For page see List of Advertisers

M. C. & J. E. Hauswirth, 232 Michigan Ave., Chicago.

For page see List of Advertisers

William J. Smyth, Michigan Ave. and 31st St., Chicago.

For page see List of Advertisers

George Witthold Co., 1657-59 Buckingham Place, Chicago.

For page see List of Advertisers.

Jacob Scholz, 644 4th Ave., Louisville, Ky.
For page see List of Advertisers

Thos. F. Galvin, 124 Tremont St., Boston.
For page see List of Advertisers

Julius A. Zinn, 2 Beacon St., Boston.
For page see List of Advertisers.

Houghton & Clark, 396 Boylston St., Boston.
For page see List of Advertisers.

Sidney Hoffman, 59-61 Massachusetts Ave., Boston.
For page see List of Advertisers.

Edward MacMullin, 194 Boylston St., Boston.
For page see List of Advertisers.

J. Breitmeyer's Sons, Detroit Mich
For page see List of Advertisers

Samuel Murray, 1017 Broadway, Kansas City, Mo.
For page see List of Advertisers

RETAIL FLORISTS - Continued

Wm. L. Rock Flower Co., 1116 Walnut St., Kansas City, Mo.
For page see List of Advertisers.

Fred C. Weber, 4326 Olive St., St. Louis, Mo.
For page see List of Advertisers.

J. N. Champlon & Co., 1026 Chapel St., New Haven, Conn.
For page see List of Advertisers.

H. G. Eyres, 11 N. Pearl St., Albany, N. Y.
For page see List of Advertisers.

David Clarke's Sons, 2139-2141 Broadway, New York.
For page see List of Advertisers.

W. H. Donohoe, 17 E. 28th St., New York.
For page see List of Advertisers.

Alex. McConell, New York.
For page see List of Advertisers.

M. A. Bowe, 1294 Broadway, New York.
For page see List of Advertisers.

Robert G. Wilson, Fulton St. and Greene Ave., Brooklyn, N. Y.
For page see List of Advertisers.

Thomas Young, Jr., 500 Fifth Ave., N. Y.
For page see List of Advertisers.

Young & Nugent, 42 W. 28th St., N. Y.
For page see List of Advertisers.

J. H. Dunlop, 96 Yonge St., Toronto, Can.
For page see List of Advertisers.

RHODODENDRONS

John Waterer & Sons, Ltd., American Nursery, Bagshot, England.
For page see List of Advertisers.

P. Ouwerkerk, Hoboken, N. J.
For page see List of Advertisers.

New England Nurseries, Bedford, Mass.
For page see List of Advertisers.

Eastern Nurseries, Jamaica Plain, Mass.
Hardy Hybrid and Dwarf Rhododendrons.
For page see List of Advertisers.

ROSES

Julius Roehrs Co., Rutherford, N. J.
Rambler Rose, Newport Fairy.
For page see List of Advertisers.

New England Nurseries, Inc., Bedford, Mass.
For page see List of Advertisers.

Bay State Nurseries, N. Abington, Mass.
For page see List of Advertisers.

Robert Craig Co., Market and 49th Sts., Philadelphia, Pa.
For page see List of Advertisers.

Dingee-Conard Co., West Grove, Pa.
For page see List of Advertisers.

F. R. Pierson Co., Tarrytown-on-Hudson, N. Y.
Hardy Roses for the Garden.

R. & J. Farquhar & Co., 6 and 7 South Market Street, Boston.
For page see List of Advertisers.

The E. G. Hill Co., Richmond, Ind.
Roses, Rhea Reid, American Beauty.
For page see List of Advertisers.

Poehlmann Bros. Co., Morton Grove, Ill.
Mrs. Potter Palmer, Cardinal, Beauty.
For page see List of Advertisers.

P. R. Quinlan, Syracuse, N. Y.
Killarney, Richmond, Bridesmaids.
For page see List of Advertisers.

P. Ouwerkerk, P. O. No. 2, Hoboken, N. J.
For page see List of Advertisers.

Henry A. Droer, 711 Chestnut St., Phila.
Hardy Climbers.
For page see List of Advertisers.

400 varieties; own roots; summer grown. Leedle Company, Springfield, Ohio.

Crimson Ramblers, 2 year, on own roots, extra strong, at 7 cents. Gilbert Costich, Rochester, N. Y.

Low-budded roses. No. 1, \$95.00; No. 1-2, \$65.00 1000. H. T. Jones, Elizabeth, N. J.

RUBBER PLANTS

John McKenzie, North Cambridge, Mass.
For page see List of Advertisers.

S. A. F. CONVENTION ACCOMMODATIONS

Tower Hotel, Niagara Falls, N. Y.
For page see List of Advertisers

SALVIAS

Salvia splendens, extra strong, 2-in. plants, \$2.00 per 100; \$20.00 per 1000. This is elegant stock, large and strong enough for 4-in. pots. N. E. Beck, Massillon, O.

Cobanzic Carnation Co., New London, Ct.
Salvia Splendens.
For page see List of Advertisers.

SEEDS

T. J. Grey Co., 32 So. Market St., Boston, Mass.
For page see List of Advertisers.

Joseph Breck & Sons, 51 and 52 N. Market St., Boston, Mass.
For page see List of Advertisers.

W. Atlee Burpee & Co., Philadelphia.
For page see List of Advertisers.

J. M. Thorburn & Co., 33 Barclay St., N. Y.
For page see List of Advertisers.

A. T. Boddington, 342 W. 14th St., N. Y.
For page see List of Advertisers.

H. F. Mitchell Co., 1017 Market St., Phila.
For page see List of Advertisers.

James Vick's Sons, Rochester, N. Y.
Vick's Superb Pansy Seed.
For page see List of Advertisers.

Hjalmar Hartmann & Co., 12 Stormgade, Copenhagen, Denmark.
Cauliflower and Cabbage Seed.
For page see List of Advertisers.

Rickards Bros., 37 E. 19th St., New York.
For page see List of Advertisers.

R. & J. Farquhar & Co., 67 So. Market St., Boston.
For page see List of Advertisers.

C. C. Morse & Co., 48-56 Jackson St., San Francisco, Cal.
For page see List of Advertisers.

H. E. Fiske Seed Co., Fanenil Hall Sq., Boston.
Primula Fringed Sinensis.
For page see List of Advertisers.

Braslan Seed Growers Co., San Jose Cal.
For page see List of Advertisers.

O. V. Zangen, Hoboken, N. J.
For page see List of Advertisers.

W. E. Allen, Salisbury, Md.
John F. Rupp, Shiremanstown, Pa.
Chinese Primrose, Chincaria, Giant Pansy Seeds.
For page see List of Advertisers.

Asparagus Pl. Nanns, \$2.50 per 1000. Plant early. Asparagus Plants 14 to 18 inches high, \$5.00 per 100. Peter Mack, Box 172, Orlando, Fla.

Davis Perfect and Burrell's Klondike Cucumber Seed, 85c. per pound. Finest slicing varieties grown. D. V. Burrell, Rocky Ford, Colorado.

SMILAX

Smilax, choice young plants from fall; \$3.00 per 1000, 2000 for \$5.00, 5000 for \$10.00; 50c. per 100 by mail. F. A. Baller, Bloomington, Ill.

SPHAGNUM MOSS

Live Sphagnum moss, orchid peat and orchid baskets always on hand. Lager & Hurrell, Summit, N. J.

SPIREA

W. W. Edgar Co., Waverley, Mass.
For page see List of Advertisers.

SPRAYERS

Charles J. Jager Co., 281-85 Franklin St., Boston.
"Showermaker," \$1. Jos. Kopesay, So. Bend, Ind.

STEAM TRAP

E. Hippard, Youngstown, O

TO-BAK-INE

E. H. Hunt, Genl. Agt., 76-78 Wabash Av., Chicago.
For page see List of Advertisers.

VEGETABLE PLANTS

R. Vincent, Jr. & Sons Co., White Marsh, Maryland.
For page see List of Advertisers.

TUBEROSES

Stump & Walter Co., 50 Barclay St., New York.
For page see List of Advertisers.

In writing to Advertisers kindly mention Horticulture

VEGETABLE PLANTS

Cabbage Plants Early Jersey Wakefield, Charleston Wakefield, Early Summer, nice plants, \$1.25 per 1,000, \$10.00 per 10,000. Dwarf Erect Cauliflower plants, \$4.00 per 1,000. Gladioli bulbs, large No. 1, fine mixture, \$4.00 per 1,000. Cash order quick. W. F. Allen, Salisbury, Md.

VENTILATING APPARATUS

Pierson U-Bar Co., 1 Madison Sq., N. Y. For page see List of Advertisers.

Foley Mfg. Co., Western Ave., between 25th & 26th Sts., Chicago. For page see List of Advertisers.

John A. Payne, 260-274 Culver Ave., Jersey City, N. J. For page see List of Advertisers.

The Advance Co., Richmond, Ind. For page see List of Advertisers.

Quaker City Machine Co., Richmond, Ind. 20th Century Ventilating Arm. For page see List of Advertisers.

VENTILATING MACHINERY, New Model encased, self-oiling gear; Standard Model Open Gear. Lord & Burnham, 1133 Broadway, N. Y.

VERBENAS

Mammoth verbenas, strong, 2 in. plants from seed, in red, white, pink, purple and striped shades, separate or mixed, \$2.00 per 100; \$20.00 per 1,000. N. E. Beck, Massillon, O.

VINCAS

4 inch Vinca Variegata at \$10 per 100. Joseph Labo, Juliet, Ill.

VIOLETS

William Sim, Chftondale, Mass. Violet Boston.

Violet cuttings, "Marla Louisa" Rhinebeck stock, rooted runners, May delivery \$20.00 M. Wm. F. Kasting Co., 383 Elliott St., Buffalo, N. Y.

WIREWORK

Reed & Keller, 122 W. 25th St., N. Y. For page see List of Advertisers.

Wirework. Write for our catalogue. Holton & Hunkel Co., Milwaukee, Wis.

William E. Hellscher's Wire Works, 28-40 Broadway, Detroit, Mich.

Headquarters for wire work. Send for list. Ball & Betz, 31 E. 3rd St., Cincinnati, O.

**WHOLESALE FLORISTS
Boston**

N. F. McCarthy & Co., 84 Hawley St., Boston. For page see List of Advertisers.

H. M. Robinson & Co., 15 Province St. and 9 Chapman Pl., Boston. For page see List of Advertisers.

Welch Bros., 226 Devonshire St., Boston. For page see List of Advertisers.

Buffalo

Wm. F. Kasting Co., 383-87 Elliott St., Buffalo, N. Y. For page see List of Advertisers.

Chicago

Chas. W. McKellar, 51 Wabash Ave., Chicago. For page see List of Advertisers.

Peter Reinberg, 51 Wabash Ave., Chicago. For page see List of Advertisers.

E. F. Winterson Co., 45-49 Wabash Ave., Chicago. For page see List of Advertisers.

J. A. Budlong, 37-39 Randolph St., Chicago. For page see List of Advertisers.

Detroit

Michigan Cut Flower Exchange, 38 and 40 Broadway, Detroit, Mich. For page see List of Advertisers.

Minneapolis

Rice Bros., 115 N. 6th St., Minneapolis, Minn. For page see List of Advertisers.

New York

J. K. Allen, 106 W. 28th St., New York. For page see List of Advertisers.

J. S. Fenrich, 110 W. 28th St., New York. For page see List of Advertisers.

**WHOLESALE FLORISTS—
New York—Continued**

Ford Bros., 48 W. 28th St., New York. For page see List of Advertisers.

H. E. Froment, 57 W. 28th St., New York. For page see List of Advertisers.

Alex. J. Guttman, 43 W. 28th St., New York. For page see List of Advertisers.

E. C. Moran, 55 W. 28th St., New York. For page see List of Advertisers.

A. H. Langjahr, 55 W. 28th St., New York. For page see List of Advertisers.

James McManus, 42 W. 28th St., New York. For page see List of Advertisers.

John I. Raynor, 49 W. 28th St., New York. For page see List of Advertisers.

W. F. Sheridan, 39 W. 28th St., New York. For page see List of Advertisers.

Traendly & Schenck, 44 W. 28th St., New York. For page see List of Advertisers.

John Young, 51 W. 28th St., New York. For page see List of Advertisers.

Moore, Hentz & Nash, 55 and 57 W. 26th St., New York. For page see List of Advertisers.

Frank S. Hicks & Co., 39 W. 28th St., New York. For page see List of Advertisers.

Wm. H. Kuebler, 28 Willoughby St., Brooklyn, N. Y. For page see List of Advertisers.

Philip F. Kessler, 55 and 57 W. 26th St., New York. For page see List of Advertisers.

A. Moltz, 55-57 W. 26th St., New York. For page see List of Advertisers.

B. S. Slinn, Jr., 55 W. 26th St., New York. For page see List of Advertisers.

Millang Bros., 41 W. 28th St., New York. For page see List of Advertisers.

Philadelphia

W. E. McKissick, 1619-1621 Ranstead St., Philadelphia, Pa. For page see List of Advertisers.

Leo Nissen Co., 1209 Arch St., Philadelphia, Pa. For page see List of Advertisers.

The S. S. Pennock-Meehan Co., 1608-18 Ludlow St., Philadelphia, Pa. For page see List of Advertisers.

Edward Reid, 1526 Ranstead St., Philadelphia, Pa. For page see List of Advertisers.

Pittsburg

J. R. Murdoch & Co., 714 Penn Ave., Pittsburg, Pa. For page see List of Advertisers.

San Francisco

Alex. Mann, Jr., Co., 1125 Polk St., San Francisco, Cal.

St. Louis

H. G. Bernal, 1402 Pine St., St. Louis, Mo. For page see List of Advertisers.

WHOLESALE PLANTSMAN

Samuel A. Woodrow, 53 W. 30th St., New York. For page see List of Advertisers.

WILD SMILAX

E. A. Beaven, Evergreen, Ala. Southern Wild Smilax: Log Mosnae. For page see List of Advertisers.

New Offers in This Issue.

ASPARAGUS PLUMOSUS.

Hugh Graham Co. (David Rust, Receiver), 104 S. 13th St., Philadelphia. For page see List of Advertisers.

BEGONIA GLOIRE DE LORRAINE.

S. S. Skidolsky, 1741 N. 18th St., Phila. For page see List of Advertisers.

CARE OF TREES.

H. L. Frost & Co., White Plains, N. Y.; Arlington, Mass. For page see List of Advertisers.

CEMETERY OR LAWN VASES.

Wm. F. Kasting Co., 383-87 Elliott St., Buffalo, N. Y. For page see List of Advertisers.

DAHLIA CHAS. LANIER.

R. & J. Farquhar & Co., 6 & 7 S. Market St., Boston. For page see List of Advertisers.

HYDRANGEA OTAKSA: BEDDING PLANTS.

F. R. Pierson Co., Tarrytown-on Hudson, N. Y. For page see List of Advertisers.

INVITATION TO VISIT.

R. Vincent, Jr. & Sons Co., White Marsh, Maryland. For page see List of Advertisers.

LILIUM HARRISII.

G. W. West, Shelly Bay, Bermuda. For page see List of Advertisers.

**MEMORIAL DAY SUPPLIES:
FLOWERS: FRESH CROP
FERNS.**

H. M. Robinson & Co., 15 Province St., Boston. For page see List of Advertisers.

PLANT TUBS.

Henry A. Dreer, 714 Chestnut St., Phila. For page see List of Advertisers.

**ROSES: BOUVARDIA HUM-
BOLDTII.**

Anderson & Williams, Waltham, Mass. For page see List of Advertisers.

**ROSES, CARNATIONS, HARDY
FERNS, FLORISTS' SUPPLIES,
FOR MEMORIAL DAY.**

Welch Bros., 226 Devonshire St., Boston. For page see List of Advertisers.

SLUG SHOT.

Hammond's Paint & S. S. Works, Fishkill-on Hudson, N. Y. For page see List of Advertisers.

VINCA MINOR.

Edmund Reardon, Cambridge, Mass. For page see List of Advertisers.

SPECIAL SURPLUS LIST

These prices holding good only until present surplus is reduced).

	Per 100	Per 100
Begonia Rex, fine collection of varieties,	\$3.00	
Begonia Thurstoni and T. Daw	2.50	Baby Rambler Rose \$2.00
Fuchsias, strong stock, 3 varieties	2.50	Clothilde Soubert Rose 2.50
Violet, Prince of Wales	2.50	Salvia Splendens 2.50
Verbenas, all colors	2.50	Ivy Geraniums 2.50
Pandanus Utilis, 1/2 in.	4.00	Dracena Indivisa 2.50
Pandanus Utilis 3 in.	3.00	Pelargoniums, 3 in. 10.00
Kaiserin Roses, Fresh propagation	3.00	Digitalis, two colors, field grown 4.00
		Campanula in variety, field grown 4.00
		Shasta Daisy, in variety, field grown 3.00

THE STORRS & HARRISON CO., Painesville, Ohio

List of Advertisers

Table listing advertisers and their page numbers, including Advance, The Co., Alen J. K., Altamonte Culture Co., American Nursery, etc.

JOHN A. PAYNE GREENHOUSE Designer & Builder

260-274 Culver Ave. JERSEY CITY, N. J.

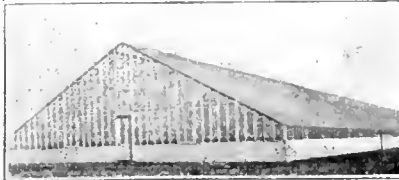

IRON FRAME SEMI-IRON FRAME TRUSS ROOF WOOD FRAME Material Only or Erected Everything for the Greenhouse

GREENHOUSES BUILDING OR CON-TEMPLATED.

- List of greenhouse projects and builders, including Deer Park, Ont.—E. Grainger & Co., Mishawaka, Ind.—Joseph St., one house, etc.

INCORPORATED.

- List of incorporated nursery and greenhouse companies, including Devils' Lake Nursery Co., Lake, N. D.; J. W. Maher, J. E. Maher, H. Hale; capital, \$5,000.



Cattle Manure In Bags Shredded or Pulverized

Best and safest manure for florists and greenhouse use, absolutely pure, no waste, no danger. Write for circulars and prices.

The Pulverized Manure Co., 31 Union Stock Yards, Chicago

HELP WANTED

TRAVELLER WANTED

by leading import house handling all kinds of foreign nursery and florists' stock excepting Dutch bulbs. Splendid opening for young man under 25 with energy, judgment, intelligence and a fair knowledge of the business.

FOREMAN WANTED

A man with good experience in Roses and Carnations to take charge of a commercial establishment growing for the wholesale trade.

W. J. DANA Wellesley Hills, Massachusetts

WANTED—An all-round handy man, experienced in outdoor gardening, familiar with trees and shrubs; horse and cow to look after; good pay and when needed extra help; cottage and vegetables. Must be sober and faithful. Address C. C., care Horticulture, 11 Hamilton Place, Boston.

SITUATIONS WANTED

GOOD MEN

When you need good men, skilled or unskilled, Write:

THOS. H. BAMBRICK

34 South 7th Street Philadelphia

Help of all kinds, including that for Florists, Nurserymen, Seedsmen and the Horticultural trade generally.

SITUATION WANTED in general greenhouse work; single, age 35, five years' experience, commercial. Address W. W., care HORTICULTURE.

SITUATION WANTED—German, married, three children, 35 years of age, capable of taking full charge of any sized place. Please state terms. Wants position now or later. Address Gardener, 418 North Perry St., Johnstown, N. Y.

FOR SALE

GREENHOUSE FOR SALE.

About 14,000 feet of glass, two steam boilers, one hot water; easy communication to Boston and New York, 1-4 mile to depot; trolley freight passes greenhouses. Three acres of land, large two-story dwelling house, large wholesale and retail business. Books open for inspection. All health reason for selling. Address Horticulturist care of HORTICULTURE.

FOR SALE—On account of my husband's death, desirable greenhouse plant; large and increasing demand for funeral designs, bouquets and bedding stuff; a dwelling house, 10,000 feet of glass; a paying business; place is stocked. Mrs. Kathrine Tully, 47 Spring Forest Ave., Binghamton, N. Y.

FOR SALE—A large consignment of 16x24 double thick American glass, A and B quality. For further information write Parsheisky Brothers, 59 Montrose Avenue, Brooklyn, N. Y.

HARDWOOD ASHES FOR SALE—We have about three tons best quality hardwood ashes. Best offer takes it. Everett Sawdust Co., 16 Adams Ave., Everett, Mass.

MISCELLANEOUS

WANTED First-class gardener and florist to invest capital in greenhouses in growing city; ideal location. Write J. C. Hennessy, La Port, Ind

IS YOUR NAME IN THE ABOVE LIST? IF NOT, WHY NOT?

Expressions from Men who Know

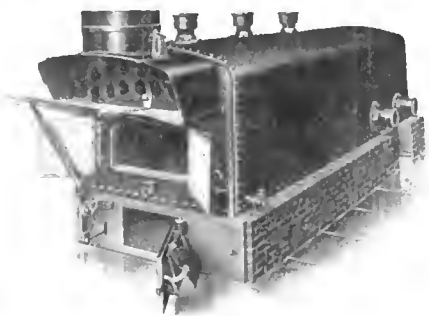

W. W. Allabaugh, Silverdale, Pa., writes:
 "Your boiler gives entire satisfaction. You will notice the No. 4 boiler is rated to warm 10,500 sq. ft. of glass and I have over 12,000 sq. ft. of glass."
 Wm. Pinchle, Ridgefield, Conn., writes:
 "I expect to enlarge my plant soon, and when I do I shall use another of your boilers. Now a few words about the boiler I bought of you in 1907. This is a No. 1 boiler, rated in your catalogue at 6,000 square feet. It is taking care of 7,000 square feet of glass in carnation houses and works to perfection. No trouble whatever in cold nights, no night fireman; easy to work and easy to coal. I consider this the best boiler on the market and I have used a good many different kinds."
 Theo. Hiedrich, Anacostia, Washington, D. C., writes:
 "No. 7 Boiler carries two houses, 20 x 172, and three houses 22 x 96, this is 3,200 square feet of glass more than its rating."
 Jacob Phillips, Rogers Park, Chicago, Ill., writes:
 "Has 2,000 square feet of glass. Can keep 60° in coldest weather. Had one boiler 15 years, only expense one set of flues. Kroeschell Boiler is so satisfactory that I do not care to try any other."
 Our No. 10 Boiler is rated at 19,500 square feet of glass
KROESCHELL BROS. CO., 35 ERIE ST., CHICAGO

The ELECTRIC CIRCULATOR

Is master of the situation.
 It **MAKES** the water circulate.
 It ensures uniform temperature.
 Its work is positive regardless of weather.
 It never gets out of order.
 It saves coal.
 It is serviceable in old houses.
 It is helpful in new houses.
 Its value has been fully demonstrated.
 Its economy is conceded.

Lower values on greenhouse products make necessary lower running expenses. Write to us today and we will send you full information as to what the Circulator can do for you, and what it will cost.

THE CASTLE COMPANY
 Heating Engineers
 170 Summer St., Boston, Mass.



DREER'S
 Florist Specialties
KEYSTONE GLASS PLANT TUBS.



Standard Flower POTS

If your greenhouses are within 500 miles of the Capitol, write us, we can save you money
W. H. ERNEST
 23th and M Street WASHINGTON D. C.

STANDARD PLATE GLASS CO.

Manufacturers—Importers—Jobbers

NOW IS THE TIME TO BUY

FRENCH OR AMERICAN GREENHOUSE GLASS

LOWEST PRICES ON REQUEST

26-30 Sudbury St. BOSTON, MASS. 61-63 Portland St.

STANDARD FLOWER POTS

Packed in small crates, easy to handle.

Price per crate	Price per crate	
1500 2 1/2 in. pots in crate \$4.88	120 7 in. pots in crate \$4.20	
1500 2 3/4 " " " 5.25	60 8 " " " 3.00	
1500 3 " " " 6.00	HAND MADE	
1000 3 " " " 5.00	49 9 in. pots in crate \$3.60	
800 3 1/2 " " " 5.80	48 10 " " " 4.80	
500 4 " " " 4.50	24 11 " " " 3.60	
320 5 " " " 4.51	24 12 " " " 4.80	
144 6 " " " 3.16	12 14 " " " 4.80	
	6 16 " " " 4.50	

Seed pans, same price as pots. Send for price list of Cylinders for Cut flowers, Hanging Baskets, Lawn Vases, etc. Ten percent. off for cash with order. Address **Hilfinger Bros., Pottery, Fort Edward, N. Y.** August Rolker & Sons, Agts., 81 Barclay St., N. Y. City.

BOSTON PLATE & WINDOW GLASS CO.

GREENHOUSE GLASS

German and American

261 to 287 A St., Boston 20-22 Canal St.

In ordering goods please add "I saw it in HORTICULTURE."

PATENTS

Trademarks and Copyrights

Send your business direct to Washington. Saves time and insures better service. Personal attention guaranteed. Twenty-five years' active service. SPECIALTY: "Working on the Failure of Others."

SIGGERS & SIGGERS

PATENT LAWYERS

Box 9, National Union Building Washington, D. C.

MASTICA

FOR Greenhouse Glazing



USE IT NOW.

F. D. PIERCE CO.

12 W. Broadway and 227 Greenwich St. NEW YORK

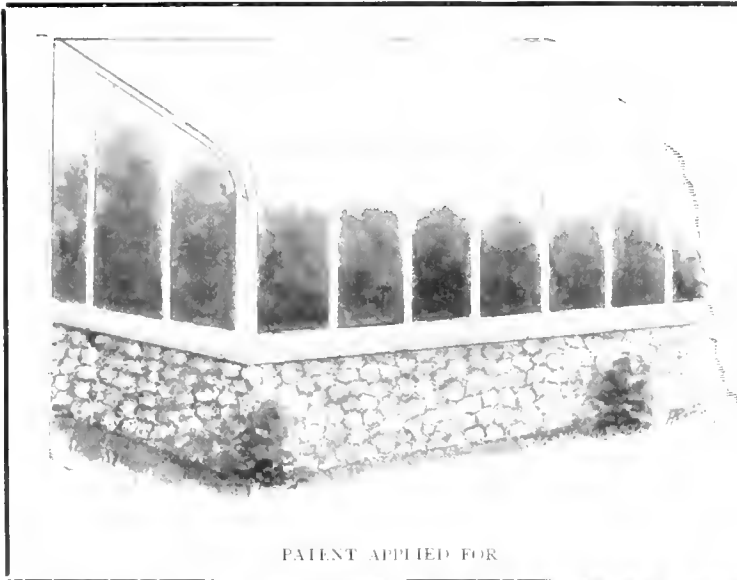

PATENT APPLIED FOR

Why My New Curved Iceless Eave is Far Superior to Anything on the Market Today

- 1st. No sash bars incased in iron, thereby eliminating all danger of bars decaying.
- 2nd. Can be used in conjunction with iron frame construction, thereby doing away with that very objectionable feature, "columns."
- 3rd. Roof bars with drip grooves, which act as conductors to carry away the condensation: **Result**, the driest roof ever used for greenhouse purposes.
- 4th. **THE MOST IMPORTANT OF THEM ALL.** The very small increase in cost over the ordinary style of construction which makes it possible to be used for commercial as well as private purposes.

William H. Lutton, Horticultural Architect and Builder
West Side Ave Station (C.R.R. of N.J.) Jersey City, N.J.

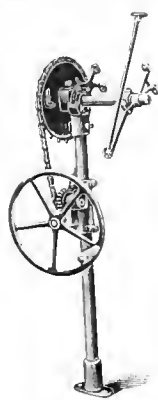

The Advance Ventilating Apparatus

The machine that does the work must be built right to do the work easily. Don't have your attention drawn away from this fact by arms, hangers, &c. Your interest is to have every thing the best and sold at fair prices.

The Advance Co.
RICHMOND, IND.

IRON PIPE

SECOND HAND

WROUGHT IRON PIPE, for Steam, Water, Gas or Oil, Fences or Posts. All Sizes. Price Low.

GEO. B. DOANE & SON
18 Midway Street, BOSTON
Telephone, Main 4419



Evans 20th Century Arm

Will not twist your shafting pipe. Give it a trial and you will use no other. Three times the power of elbow arms.

Write for Catalogue

QUAKER CITY MACHINE CO.
Richmond, Ind.

Holds Glass Firmly

See the Point of **PEERLESS**

Glazing Points are the best. No rights or lefts. Box of 1,000 points 75 cts. postpaid.

HENRY A. DEER.
714 Chestnut St., Phila., Pa.

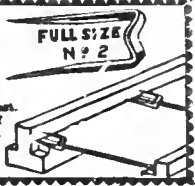

The **FLORISTS' HALL ASSOCIATION OF AMERICA**, insurer of 28,000,000 sq. ft. of glass. For particulars address **John C. Esler, Sec'y, Saddle River, N.J.**

THE FOLEY MFG. CO.

CHICAGO

Completely equipped with up-to-date machinery for the making of material for

GREENHOUSE CONSTRUCTION

From a Full Supply of Thoroughly Seasoned Lumber

Send your sketches to our draughtsmen for completion and suggestion. Permit us to figure your proposed work, large or small.

We guarantee our prices will save you money

FOLEY VENTILATING APPARATUS IS THE BEST

Simple in Erecting. Is Easiest of Operation. It Will Last a Lifetime. Its Price is the Lowest. Will Ventilate Any Size House. Prices and Circulars on Application.

Our 1908 Catalogue Greenhouse Material Sent Postpaid on Request.

THE FOLEY MFG. CO., WESTERN AVENUE 25th and 26th STS., CHICAGO

S. JACOBS & SONS

Manufacturers of GULF CYPRESS

GREENHOUSE MATERIAL

HOT-BED-SASH & FRAMES

Jobbers in **Boilers-Pipe-Fittings** and

GLASS on which we can quote attractive prices. Disc on large quantities.

We furnish everything for Greenhouse Building

1365-1379 Flushing Avenue
BROOKLYN, - NEW YORK

I. CASSIDY

Designer and Builder of

Iron and Wood Greenhouses

Factory: Summer Ave and Erie R. R.
Newark, N. J.

R. TONAWANDA, N. Y.



CYPRESS SASH BARS 82 feet or longer

HOT BED SASH

PECKY CYPRESS BENCH LUMBER

GREENHOUSES

ERECTED AND EQUIPPED COMPLETE IF DESIRED

Write for Circular "D" and Prices

The A. T. STEARNS LUMBER CO.
NEPONSET, BOSTON, MASS.

In writing advertisers kindly mention HORTICULTURE.

GREENHOUSE CONSTRUCTION LUMBER

John C. Moninger Co.
117 E. Blackhawk St., CHICAGO

SAVES 25% TO 30% IN FUEL
 Burns Pea or No. 1 Buckwheat Coal. Requires attention only once a day in ordinary weather (twice in severe). Write for catalogue and reason why every florist should use the

SPENCER—
The Heater that Thinks!
WEATHERED COMPANY
 Sole Agents
Box 789, NEW YORK CITY
 Main Office and Works:
 Orient and West Side Avenue,
 JERSEY CITY, N. J.

Don't forget our Greenhouse Building Catalogue. Every type of house erected complete, or material only.

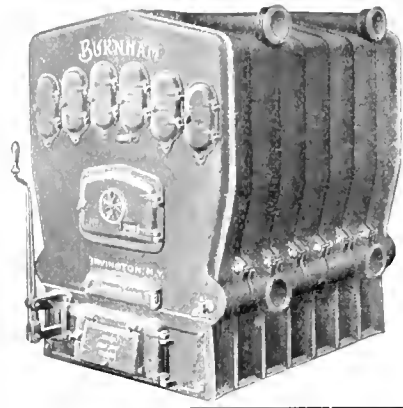

That Matter of Coal

Either kind—soft or hard—burned in the "Burnham" Boilers and no change of grate. That's one part of the coal question—the other, one of economy, we can prove!—prove by those who have proven it.

SEND FOR NEW CATALOG.

LORD & BURNHAM CO., 1133 BROADWAY, NEW YORK

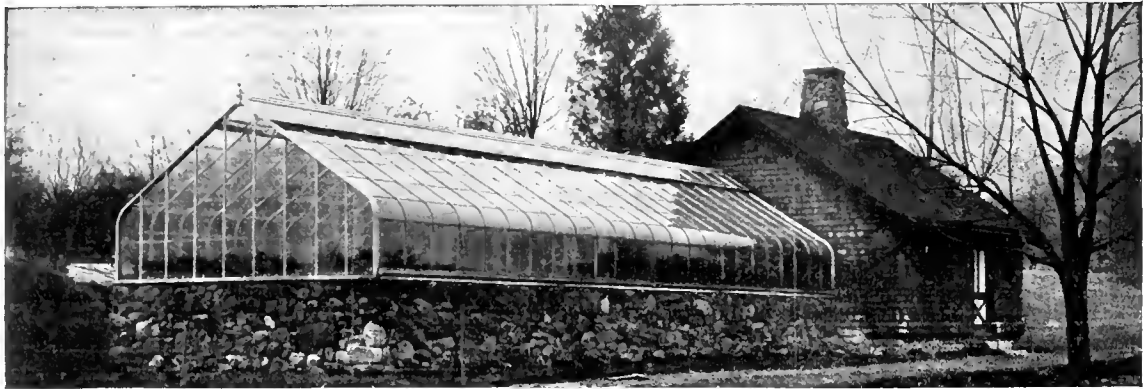

THEY ARE GALVANIZED

Every iron part is heavily galvanized which means no destructive rusting. Then they are aluminum finished which assures lasting brightness. There is also simplicity of construction, endurance, strength, lightness, attractiveness, unequalled productiveness and low cost of maintenance.

Send for catalog.

The ideal construction for private estates, parks, public institutions and florists' showrooms

U-BAR GREENHOUSES

PIERSON
 DESIGNERS AND BUILDERS



U-BAR CO.
 1 MADISON AVE., NEW YORK

HORTICULTURE

Vol. VII. MAY 23, 1908 No. 21

LIBEX
NEW
BOT
GARD

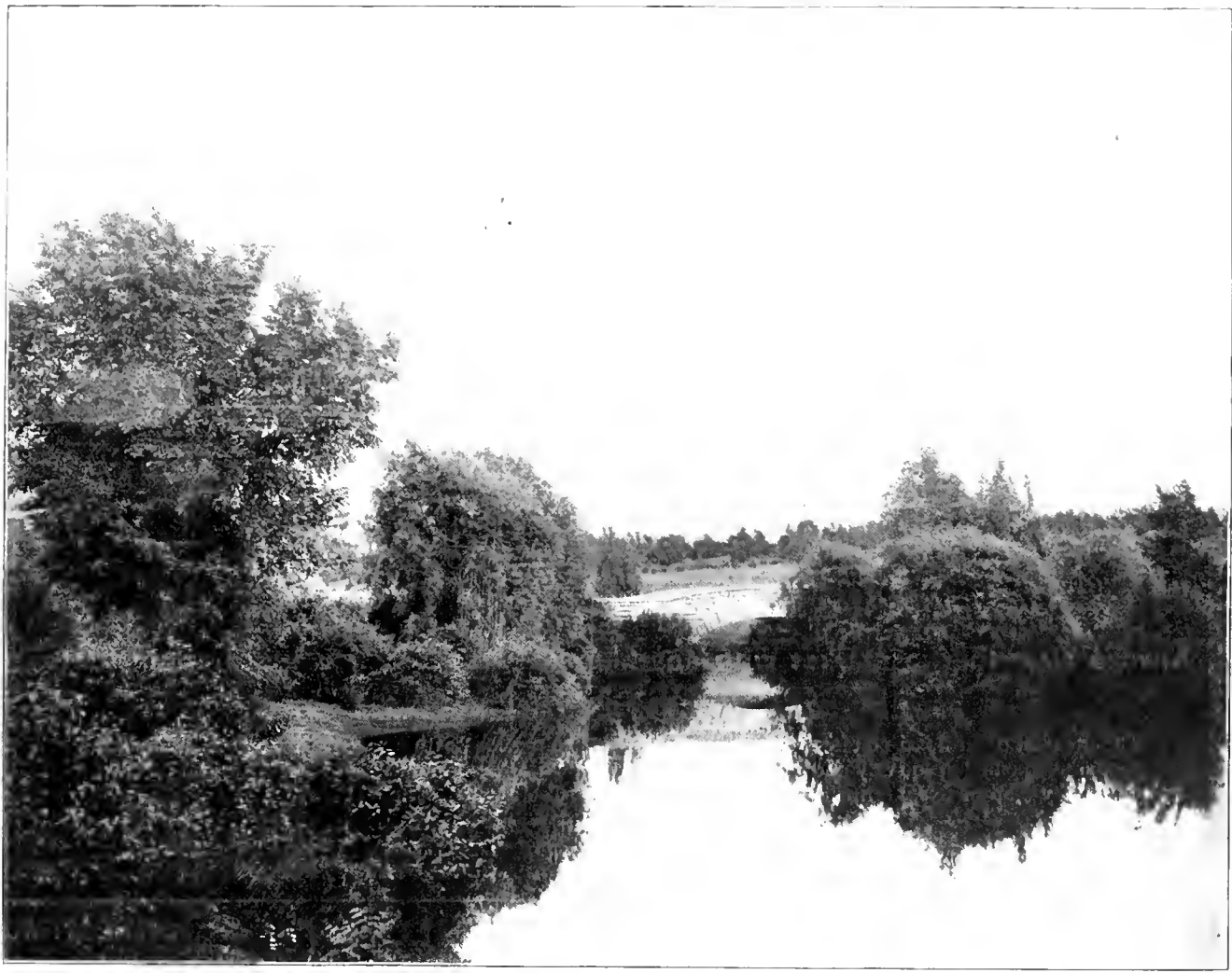

SCARBORO POND
In Franklin Park, Boston

*Devoted to the
FLORIST, PLANTSMAN,
LANDSCAPE GARDENER,
and
Kindred Interests*

*Published
EVERY SATURDAY
At 11 Hamilton Place,
BOSTON, MASS.
Subscription, \$1.00*

MAY 25 1908

BEFORE YOU BUILD GET FOLEY'S ESTIMATE

THE FOLEY

GREENHOUSE MATERIALS

THE BEST

ALL HEART SUN-DRIED CYPRESS. UNEQUALLED. CUT EXACT SIZE AND FIT. PERFECT WORK.

THE FOLEY

VENTILATING APPARATUS

THE BEST

ALWAYS SECURING PERFECT VENTILATION. ADAPTABLE TO ANY SIZE HOUSE. GET CIRCULARS.

THE FOLEY

HOTBED SASH AND FRAMES

THE BEST

SASH OPEN OR GLAZED. STANDARD SIZES IN STOCK. Get Our Figures and Suggestions on Your Proposed Work. 1908 Illustrated Catalogue Sent Postpaid.

SASH,
DOORS,
MOULDINGS,

ALL KINDS MILL WORK

INTERIOR FINISH

FOR ANY WOODWORK USED IN CONSTRUCTING RESIDENCES, FACTORIES, SCHOOLS and PUBLIC BUILDINGS. GET OUR FIGURES ON ANY JOB.

With our force of architects, draughtsmen, estimators and skilled workmen we can quickly and carefully fill, and promptly ship any order. Excellent work at lowest prices.

THE FOLEY MFG. CO., Chicago

OFFICES, FACTORY, SHEDS AND YARDS: WESTERN AV., BET. 25th AND 28th STS.

H. BAYERSDORFER & CO.

Known to the Trade for the past 30 years as the

Representative Florists' Supply House of America

Always first in the market with anything that is new, novel and appropriate.

... FOR MEMORIAL DAY ...

The greatest of all floral holidays, we have prepared for your needs with a stock of desirable and useful goods, unequalled in quality and extent anywhere on this continent and at prices that cannot be beaten. Orders by mail or telegraph will be filled immediately. Catalogue on application.

H. BAYERSDORFER & CO., 1129 Arch St., Philadelphia

INDISPENSABLE

EVERY FLORIST NEEDS IT

EVERLASTING

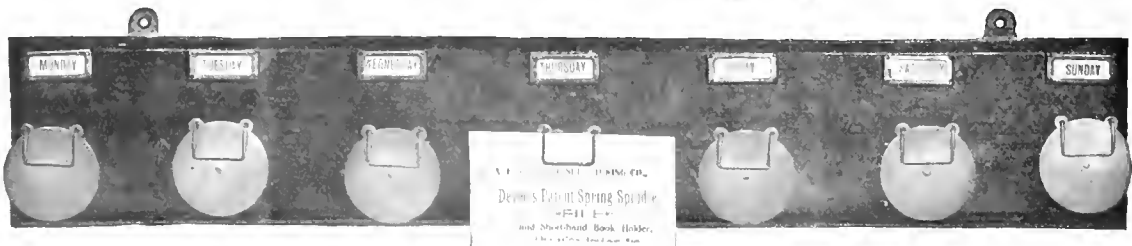

LEWIS'S WEEKLY BOARD FILE

takes the place of Memo, or Order Books, also a line of nails or of the old-fashioned spike spindle sets, from both of which it takes time to remove all but the top paper. Just the thing and the latest device for sales slips, orders to be filled, this week's daily engagements, and a reminder of next week's. The Board File is made up of sets of our Devoe Patent Spring Spindle File. The board is of polished tolen oak, 18 1/2 inches, with brass name plates in which are the days of the week neatly printed. Can remove days of week and place Salesman's name in for cashier's desk. Its good points are that it is Cheap, Ornamental, a Time Saver, makes no holes in the paper, cannot injure Operator or Customer. PRICE: Set of 7 on a Board, or Florists' use, \$2.00; Set of 6 on a Board (omitting Sunday), \$1.75. Devoe's Spring Spindle Paper File, Typewriters' Note Book, Hat and Reading Book Holder, comes in Mission Green, Mission Black, Polished Golden Oak base, and is the only perfect Spindle File, best and cheapest Note Book Holder. While in use any Paper can be changed or displaced without removing "Aemos", Safe Slip, Copy Lists, Etc. SINGLE FILE, 4 in 1, postpaid 25 cts. Wanted—Florist Supply Houses to Handle. State Rights For Sale. THE A. F. LEWIS MFG. CO., E. BOSTON, MASS.

Dreer's Offer of POTTED ROSES

We can still furnish the following list of Roses in good plants in 5 and 6 inch pots.

Hybrid Perpetual, Moss and other Hardy Roses.

Strong two-year-old plants, nearly all in 6-inch pots

	Per 100
Alfred Colomb	25.00
Alfred K. Williams	25.00
Bianche Moreau	25.00
Baroness Rothschild	25.00
Baron de Bonstetten	25.00
Camille Bernardin	25.00
Capt. Christy	25.00
Crested Moss	25.00
Comtesse de Turanais	25.00
Common Provence	25.00
Clio	25.00
Comtesse of Oxford	25.00
Charles Lefebvre	25.00
Crimson Globe	25.00
Duke of Edinburgh	25.00
Earl of Dunferlin	25.00
Fisher Holmes	25.00
Francis Michelon	25.00
General Jacqueminot	25.00
Gloire de Margottin	25.00
Gloire de Lyonnaise	25.00
Gloire de Mosses	25.00
Her Majesty	25.00
Jean Liabaud	25.00
Mrs. R. G. Sharman Crawford	25.00
Mrs. John Laing	25.00
Label Morrison	25.00
Time Planter	20.00
Time Victor Verdier	25.00
Time Gabrielle Luizet	25.00
Marchionesse de Lorne	25.00
Marie Baumann	25.00
Nova Zembla	25.00
Princess Adelaide	25.00
Paul Neyron	25.00
Prince Camille de Rohan	25.00

	Per 100
Queen of Queens	25.00
Rodocanachi	25.00
Rugosa Red	15.00
" White	15.00
Tom Wood	25.00
Victor Verdier	25.00
White Baroness	25.00

Baby Rambler Roses.

Pink Baby Rambler (Anchen Muller). Brilliant luminous pink, a shade that is always admired. \$3.00 per dozen; \$25.00 per 100.

White Baby Rambler (Katherina Zeimet). Pure white flowers, showing the yellow stamens very prettily, produced in large candelabra-shaped trusses. \$3.50 per dozen; \$25.00 per 100.

Hybrid Tea and Other Everblooming Roses.

	Per 100
Antoine Rivoire	\$20.00
Belle Siebrecht	25.00
Bessie Brown	30.00
Belle Lyonnaise	25.00
Caroline Testout	25.00
Celia (new)	50.00
Comtesse Riza du Parc	20.00
Corallina	30.00
Countess Cairns	30.00
Earl of Warwick	25.00
Farbin Konigin	25.00
Frau Lila Rautenstrach	25.00
Grace Darling	30.00
Gladys Harkness	30.00
Gustav Grunewald	25.00
G. Nabonnand	30.00
Hermosa	20.00
Hon. Edith Gifford	30.00
Johanne Sebus	25.00
Joseph Hill	35.00
Konigin Carolla	30.00

	Per 100
La France	25.00
La Detroit	25.00
Lady Battersea	20.00
Liberty	20.00
Marie Van Houtte	25.00
Mrs. B. R. Cant	20.00
Mildred Grant	25.00
Mme. Abel Chatenay	25.00
" Edmee Metz	25.00
" Jules Grolez	20.00
" de Watteville	25.00
Papa Gontier	25.00
Pharisaer	20.00
Prince de Bulgarie	20.00
Queen's Scarlet, or Agrippina	20.00
Souvenir de Catherine Guillot	10.00
" de President Carnot	30.00
" de la Malmaison	25.00
The Warrior (new)	50.00
Viscountess Folkestone	25.00

Rambler, Climbing and Trailing Roses.

	Per 100
Crimson Rambler	20.00
Gloire de Dijon	25.00
Philadelphia Rambler	20.00
Prairie Queen	20.00
Persian Yellow	25.00
Sweet Brier	15.00
" Lord Penzance	25.00
" Lady Penzance	25.00
" Meg Merrilies	25.00
" Anne of Gierstein	25.00
" Brenda	25.00
Trier	25.00
Wichuraiana Evergreen Gem	20.00
" Pink Roamer	20.00
" South Orange Perfection	20.00
" Triumph	20.00
" Universal Favorite	20.00
Yellow Rambler	20.00

HENRY A. DREER, 714 Chestnut Street, Philadelphia, Pa.

LIVE FENCES

Amor River and California, strong plants, at \$25.00 per M. Other varieties. Prices on application.

PETER'S NURSERY COMPANY, - Knoxville, Tenn.

RHODODENDRONS

Hardy Hybrids - 1 1/2 ft., 2 ft., 3 ft., 4 ft., 5 ft.

Box - All sizes Bush, Pyramid and Standard.

Roses - Large assortment, Hybrid and Climbing.

Herbaceous Perennials, 1000 varieties
Send for General Catalog and Trade List

The NEW ENGLAND NURSERIES, Inc.
BEDFORD, MASS.

Hardy Rhododendrons, Azaleas Conifers, Clematis, H. P. Roses, Shrubs and Herbaceous Plants from our
HOLLAND NURSERIES

Prices Moderate

P. OUWERKERK, 216 Jane St., Weehawken Heights, N. J.

FOR SALE

5000 Vinca Minor "Myrtle"

EDMUND REARDON

Telephone 1034. Cambridge, Mass.

ROSES

100 of the best Hardy sorts.

HYBRID PERPETUALS

Finest English Grown Plants

Dozen, \$3.50; 100 \$25.00

EVERBLOOMING HYBRID TEAS

Bloom from Midsummer until frost.

Dozen \$5.00; 100, \$35.00

Hardy Climbing Roses

All the leading sorts.

Catalogue Free on Application.

R. & J. FARQUHAR & CO.

6 and 7 So. Market Street,
Boston, Mass.

CHRYSANTHEMUMS

FOR IMMEDIATE ACCEPTANCE

I offer 100 Single Chrysanthemums for \$8.00, in 10 or more varieties.

100 large flowered kinds in 10 varieties for \$5.00. This will include some of the newer sorts and is a special cash offer open only to readers mentioning *Horticulture*.

CHARLES H. TOTTY, MADISON, N. J.

ROOTED CHRYSANTHEMUM CUTTINGS

Glory of the Pacific, Polly Rose, Ada Byron, Kalb, Halliday, Harry Sinclair, Bonnalton, \$1.50 per 100.
Fair Maid Carnation Cuttings \$1.00 per 100; \$8.00 per 1000.

H. F. Littlefield, 552 Main St., WORCESTER, MASS.

MONEY MAKERS

CHRYSANTHEMUMS - White and Yellow Bonnalton, Ivory, Rooted Cuttings, \$10.00 per 1000.
Nutt, Poltevine, Ricard and other BEST Geraniums, 4-in. stock, \$7.00 per 100.

H. L. CAMERON
North Cambridge, Mass.

HYDRANGEA OTAKSA Large Plants in Tubs and Half-barrels for July and August Flowering

We make a specialty of these, and have a magnificent lot of large plants, which we can supply in any quantity — from single plants up to carload lots. **Large plants in tubs, \$2 and \$3 each. Extra large plants in half-barrels, \$5 and \$7.50 each.** We can supply, also, a fine lot of plants in 6-in. pots, now in bud and bloom, fine for immediate sale or Decoration Day trade, at **\$5 per dozen.**

VINCAS and ENGLISH IVIES. Extra fine plants in 3½ and 4-in. pots, for vases, tubs, etc. **\$8 per 100; extra size, \$10 per 100.**

FRENCH BARGUERITES in bloom. Large plants, 6-in. pots, extra fine, **\$5 per dozen.**

CANNAS. Started plants in 3½ and 4-in. pots, ready for immediate planting. Mme. Nardy, Mlle. Berai, Robert Christie, Golden King, Pennsylvania, L. Patsy, Florence Vaughan, Pandora, Austria, Souv. d'Antoine Crozy, Kohalton, Pierson's Premier, Queen Charlotte, Frederick Henry, etc. **Extra strong plants, \$6 per 100.**

PANSIES, ENGLISH DAISIES, and FORGET-ME-NOTS. **\$3 per 100.**

CROTONS for bedding. Extra strong plants, 3½-in. pots, **\$25 per 100; 5-in. pots, \$50 per 100.**

ACALYPHA PUSAICA. Extra choice, for bedding, 2½-in. pots, **\$6 per 100.**

PANDANUS VEITCHII. 4-in. pots, **\$9 per dozen; 6-in. pots, \$12 per dozen; larger plants, \$2 to \$3.50 each**—according to size.

FIGUS ELASTICA. 5-in. pots, **\$4 per dozen; 6-in. pots, \$6 per dozen.**

DRAENA FRAGRANS. Extra large plants in 6-in. pots, 2 ft. high, **\$12 per dozen.**

FERNS, Assorted. Extra heavy plants, 2¼-in. pots, **\$3 per 100; 3½-in. pots, extra heavy, \$10 per 100.**

NEPHROLEPIS PIERSONI ELEGANTISSIMA. 2¼-in. pots, **\$6 per 100; 3½-in. pots, \$15 per 100; 6-in. pots, \$6 per dozen; 8-in. pots, \$12 per dozen.**

BOXWOOD, Pyramids. Extra fine plants, **\$2 and \$3 each.**

CARNATIONS, Winsor and White Enchantress. We can supply these in quantity, ready for immediate planting. Strong established plants from 2¼ in. pots, **\$7.50 per 100; \$60 per 1000.**

F. R. PIERSON CO., Tarrytown-on-Hudson, New York

The Roses that Win

MRS. POTTER PALMER, CARDINAL American Beauty and Other Standard Varieties. Rooted from Our Famous Stock. Send for Prices.

POEHLMANN BROS. CO.
Morton Grove, Ill.

ROSES

A SPECIALTY

The Dingee & Conard Co. West Grove PA.

RHEA REID

READY NOW, Own Root, \$30 per 100, Grafted, \$35 per 100.

AMERICAN BEAUTY

Fine Young Stock, \$6 per 100, \$50 per 1000.

THE E. G. HILL CO., Richmond, Ind.

AMERICAN NURSERY CO., COMBIN-ING

FRED'K W. KELSEY, New York City
F. & F. NURSERIES, Springfield, N. J.
BLOODGOOD NURSERIES, Flushing, L. I.
N J & L I. NURSERIES

We can supply you every need. Write for prices
Sales Department

150 BROADWAY, - NEW YORK

CARE OF TREES

12 years' experience. Endorsed by the United States Department of Agriculture. Graduates of Agricultural Colleges and Schools of Forestry. Field force of 50 expert men. Everything to do with trees,—pruning, removing dead wood, treating and closing cavities, spraying for both insects and diseases, fertilizing, forest planting, tree moving, etc. Write us.

H. L. FROST & CO.

Landscape Foresters and Entomologists.
White Plains, N. Y. Arlington, Mass

Berberis Thunbergii

18 to 24-in., 12 to 18-in., all well branched and good roots. 10,000 Vinca Minor (Grave Myrtle). 5000 Red Oak, 3 to 5 ft. Norway Spruce 12 to 18-in.

OAK HILL NURSERIES, Roslindale Mass.

FINEST LOT OF

HARDY HYBRID RHODODENDRONS

ALSO DWARF RHODODENDRONS
ANDROMEDA FLORIBUNDA

READY FOR IMMEDIATE SHIPMENT
ORDER TODAY

EASTERN NURSERIES, JAMAICA PLAIN, MASS.

RHODODENDRONS, ANDROMEDAS, KALMIAS AND SPECIMEN EVERGREENS

JOHN WATERER & SONS, LD.

AMERICAN NURSERY

BAGSHOT, - - - ENGLAND

HARDY NORTHERN GROWN NURSERY STOCK

At Reasonable Prices

FRUIT AND ORNAMENTAL TREES, SHRUBS, VINES, ROSES AND HERBACEOUS PERENNIALS IN GREAT VARIETY

Catalogue and Price List for the asking

BAY STATE NURSERIES, NORTH ABINGTON, MASS.

NEW — NEW

RAMBLER ROSE "NEWPORT FAIRY"

To be disseminated Spring, 1908. Ask for illustrated pamphlet and prices

JULIUS ROEHRS CO., Rutherford, N.J.

Prices Quoted in these Columns are for Dealers Only. When Writing to Advertisers Please Mention HORTICULTURE.

Notes from the Arnold Arboretum

The Lilacs and more particularly the large group along the driveway leading up the Overlook Hill are at present the chief attraction at the Arboretum. About the middle of the month many of the varieties and hybrids of *Syringa vulgaris* had opened their first flowers. The earliest white Lilacs are the single-flowered *Alba Major*, *Virginalis* and *Marie Legraye*, one of the best whites. Of the single-flowered Lilacs with purplish or lilac flowers in different shades the earliest are *Princesse Marie*, *Croix de Brabry*, *Justii*, *C. S. Sargent* and *Fuerst Lichtenstein*, while of the double flowered varieties of the same color *Mathieu de Dombasle*, *Lemoinei*, *Jean Bart*, *Leon Simon*, *Madame Jules Finger* and *Renouance* must be named as the earliest. Besides *Syringa oblata* mentioned in the last issue there is another very early species introduced recently by Professor Sargent from Peking where he found it cultivated in gardens: this is the white flowered *Syringa affinis*. Another new Chinese Lilac was received recently from Europe under the name *S. Giraldii*, but that name really belongs to quite a different species related to *S. villosa* and not in cultivation, while our *S. Giraldii* in many respects greatly resembles *S. affinis*, of which it may possibly be the wild purple-flowered form. Both new Lilacs differ from *S. oblata* in the rather loose and straggling habit and the slender elongated racemes and will probably prove valuable in the hand of the plant-breeder for the creation of a new race of early blooming Lilacs.

A beautiful tree now in bloom and very striking on account of the light rosy-purple color of its flowers is the well known Red-bud, *Cercis canadensis*; of this exists also a white flowered variety still rare in cultivation, *Cercis canadensis* var. *alba*, which however, scarcely merits preference before the type. More beautiful than the common is the Chinese Red-bud, *Cercis chinensis* (*C. japonica*), which has larger flowers, but unfortunately is not perfectly hardy in our climate. The finest of all is *Cercis racemosa* with rosy-pink flowers in 10 to 30-flowered pendulous racemes; of this we possess only young seedlings raised from seeds sent last year by E. H. Wilson from Central China: its hardiness, of course, remains to be tested.

The first Rhododendrons are now in bloom. Of the Azalea-group the native Rhodora, *Rhododendron canadense*, is passing, while the southern *R. vaseji* with its delicate pale pink flowers is coming into bloom and an allied species from Japan, *R. rhombicum*, shows its beautiful pure purple flowers. *Rhododendron Kaempferi*, the only species of the Azalea indica-group hardy in this region, is making a great display with its masses of orange-red or brick-red flowers. The earliest of the true Rhododendrons are hybrids of *R. caucasicum*, of which the var. *Clio* with bluish flowers changing to nearly white and *R. caucasicum* var. *pictum* with pink flowers pale in the centre are now in bloom. *Rhododendron praecox*, a hybrid of *R. dahuricum* and *R. ciliatum*, has beautiful pale purple flowers but unfortunately is not perfectly hardy and the foliage is usually more or less injured during the winter which makes the plant unsightly in spring: its variety *Early Gem* has pale lilac flowers.

Fothergilla major and the smaller and lower *F. alnifolia* (*F. carolina*) are now objects of striking beauty with their feathery spikes of white flowers: they are still rarely seen in gardens and parks, though they certainly merit to be planted oftener.

To the Apples mentioned in the last issue should now be added *Malus Arnoldiana*, a small tree of excellent habit loaded with large pink flowers changing to white:

it is probably a hybrid of *M. floribunda* and certainly one of the most beautiful of the crab-apples. Another fine species is *Malus spectabilis*, an upright growing tree with semi-double pink flowers. A pretty shrubby species with pure white flowers is the Japanese *Malus Sargentii*.

Chaenomeles Maulei (*Cydonia Maulei*) is now covered with its bright orange-scarlet flowers. Of *Chaenomeles japonica* (*Cydonia japonica*) a large collection of its beautiful varieties has been planted, but the plants are yet too small to flower well.

Diervilla praecox shows its dull purple flowers much in advance of the other Diervillas, but on account of its dull color it is less effective than most of the later varieties. *Lonicera tatarica* and some other species are beginning to bloom and some Viburnums as *Viburnum alnifolium*, *V. Lantana* and *V. burjaticum*, a recently introduced Chinese species of little ornamental value, are now in flower.

Alfred Rehder.

Prunus Pendula (Maxim)

This picturesque and charming tree, the Japanese Weeping Rose-flowered Cherry, is the very finest of the flowering cherries. What is more to its credit, it takes high rank in our list of ornamental trees and shrubs. Indigenous to Japan, it is highly esteemed by the Japanese and is frequently depicted in their works of art. With us it is a small tree, attaining a height of twelve to fifteen feet. The branches are spreading and pendulous, and the form distinctly weeping. Yet in contrast to most of the weeping trees it is very graceful in habit. This natural charm is lost, however, if the plant is grafted standard-high. The union of the stock and scion should be close to the ground. Late in April, or perhaps more frequently during the first week in May, it is completely covered with its rosy pink flowers. These may tarry for a week, though often their charm departs in a shorter time. The flowers precede the leaves, are nearly an inch across and are borne on long, slender pedicels in two or four-flowered clusters. The foliage is somewhat thin and is of no particular merit. Perhaps the tree's most successful use is in a group which is composed of its congeners, the flowering cherries, almonds and peaches. Yet it is not to be despised in the shrubbery surrounded with such shrubs as are its equal in rank. Then it often proves most satisfactory as a specimen plant.

Very similar, except in habit of growth, is *Prunus subhirtella*, which is considered by some to be a distinct species and by others to be identical with *Prunus pendula*. Whatever we may think of its botanical position, it is certainly sufficiently distinct in habit to warrant planting. Instead of possessing the graceful weeping form, this little tree is erect, yet withal light and airy in appearance. Then the flowers are identical in beauty with those of the Japanese Weeping Rose-flowered Cherry. In many positions it might be more desirable than a weeping form as well as being always interesting for the additional variety which it affords.

These trees are vigorous and hardy and apparently free from diseases and insect pests. Nor are they difficult to grow, although for the best results they require a deep, loamy, well-drained soil, an abundance of plant food and good care.

Daniel A. Clarke.

HORTICULTURE

VOL. VII

MAY 23, 1908

NO. 21

PUBLISHED WEEKLY BY

HORTICULTURE PUBLISHING CO.
11 Hamilton Place, Boston, Mass.

Telephone, Oxford 292

WM. J. STEWART, Editor and Manager

SUBSCRIPTION PRICE

One Year, in advance, \$1.00; To Foreign Countries, 2.00; To Canada, \$1.50

ADVERTISING RATES

Per Inch, 30 inches to page \$1.00.
Discounts on Contracts for consecutive insertions, as follows:
One month (4 times) 5 per cent.; three months (13 times) 10 per cent.;
six months (26 times) 20 per cent.; one year (52 times) 30 per cent.
Page and half page spaces, special rates on application.

Entered as second-class matter December 8, 1904, at the Post Office at Boston, Mass. under the Act of Congress of March 3, 1879.

CONTENTS

COVER ILLUSTRATION—Scarboro Pond, Franklin Park.	
NOTES FROM THE ARNOLD ARBORETUM—Alfred Rehder	685
PRUNUS PENDULA—Daniel A. Clarke	685
THE CHIONODOXAS—Robert Cameron	687
BRITISH HORTICULTURE—W. H. Adsett	687
NEWS OF THE CLUBS AND SOCIETIES: Gardeners' and Florists' Club of Boston—New Haven County Horticultural Society—Society of American Florists—Buffalo Florists' Club—St. Louis Florists' Club—Pennsylvania Horticultural Society—American Association of Park Superintendents—Club and Society Notes	688
THE ART OF SELLING—F. E. Palmer	689
OBITUARY—William Scott, portrait—Thomas Green—G. W. Spinney	690
SEED TRADE	694
FLOWER MARKET REPORTS: Boston, Buffalo, Chicago, Indianapolis, New York, Philadelphia	701
MISCELLANEOUS: A New Ornamental Grass Some Azalea Awards at Ghent Les Bibliothèques Horticoles Paris Chrysanthemum Show Hartford's New Superintendent of Streets, Alex. Cumming, portrait Rochea balcata Publications Received Business Changes Plant Imports Incorporated Propagation of Scindopitys verticillata Greenhouses Building or Contemplated Personal News Notes New Retail Flower Stores Le Chrysanthème Philadelphia Notes	688 690 690 691 691 691 694 695 695 695 696 698 698 698 698 701

surdities as chrysanthemums with many colors grafted on one plant are distasteful to most plant lovers and in the markets where the most refined people are served they find but few takers. Our observation in the past few years is that even the old-fashioned flat-topped azalea has been losing caste and that the more loosely branched specimens with somewhat informal, yet symmetrical, contour are usually preferred.

A wise and patriotic measure

The passage by the United States Senate of the bill providing for national control of the White Mountain and southern Appalachian forests, after a long and, at times, almost hopeless struggle will, we believe, be looked upon in coming time as one of the wisest and most patriotic acts of the law makers of our day. To anyone who has given the subject any attention and realized the menace to our industrial resources, not to mention the question of scenic beauty, which the deforestation of the watersheds of our streams means, the opposition to this bill seems almost inexplicable. The country owes a big debt of gratitude to President Roosevelt, the American Forestry Association and other organizations, and all those devoted men in public and private life who have labored for years on behalf of this project. Now let us have the duty taken off wood pulp and other forest products, the enormous demand for which has been stripping our country of one of its best assets.

The amplitude of salesmanship

“The art of selling,” which proved such an interesting topic in F. E. Palmer’s talk before the Boston club last Tuesday evening might easily furnish themes for a score of good essays. In the florists’ business, as compared with the art of growing, salesmanship has never been given its proper relative importance. It must have become very evident to those who listened to the brief and very superficial discussion which followed Mr. Palmer’s paper that the subject of selling covers a much wider field than many of them had realized. It has often been asserted by those who were familiar with the flower trade in a broad-gauge way that the marketing of a crop of flowers to good advantage demands the exercise of intelligence and ability fully equal to that required for the production of the crop. The word “marketing” is used as applying not only to the moving of the goods from the possession of the producer to the dealer but also to their further disposition until they have finally reached the consumer. For the retail dealer to accuse the grower of shortsighted methods, or vice versa, looks to the unprejudiced outsider as a case of “the pot calling the kettle black.” In seeking an explanation of the better conditions said to exist, for instance, in Chicago, as compared with certain other cities it might be well to consider how much may be due the wholesale shipping trade for this circumstance; also to ask where the responsibility lies for the decadence of the wholesale shipping trade in quarters where it formerly flourished; further, whether it is or is not good salesmanship for the producer to advance the price of his product as soon as a shipper approaches him with a call for a large quantity of stock to be distributed to other markets; and still further, how the street fakir outlet compares in net results with the shipping trade outlet, in the disposal of the surplus.

Referring to the comment by Mr. Haerens, elsewhere in this paper, relative to the lack of appreciation in America for the “fan-shaped” azaleas we think the tendency of taste among people in this country is away from stiff and unnatural shapes in plants and floral work. All these distortions—for that is what they are—such as fan-shaped azaleas or chrysanthemums, Crimson Ramblers trained into forms of automobiles, crowns and Teddy bears, also such ab-

The Chionodoxas

In a recent issue I mentioned these charming plants, but too much can't be said in their favor. In the very places one would expect to see large masses of these early flowering bulbous plants they are conspicuous by their absence. In our cemeteries and public gardens where very large sums of money are expended each year in raising the common run of bedding plants, those in charge of such places grudge to spend a few hundred dollars in these charming spring blooming plants.

HORTICULTURE will be doing good service if it will only point out and impress upon the owners of gardens and grounds the absurdity of not enjoying their gardens very much earlier than they do. *Chionodoxa Luciliae*, *C. gigantea*, and *C. Sardensis* can be bought for five dollars a thousand and in larger quantities they can be had for much less. What a feast for the eyes ten thousand *Chionodoxa gigantea* all in one bed would make! They can be bought for a little more than forty dollars. Can any one raise bedding plants as cheaply as this?

These early-flowering bulbous plants should not be put in beds that are to be filled up during the summer with geraniums, cannas or any deep-rooting plants, but should be planted where they can remain for several years without being disturbed. When the leaves begin to ripen the beds may be filled up for the summer months with shallow-rooting annuals. In the fall when the annuals are killed by frost the beds may be cleaned up and pointed over and given a coating of well-rotted manure. If given this little care the bulbs will keep on increasing and blooming stronger and more profusely each year.

You must not think I am prejudiced against bedding plants. I am not. I love all kinds of plants and there are places in our gardens for them all if we know how to use them properly. These notes are mainly to point out that many people do not get as much pleasure out of their gardens as they should if they knew the earliest reliable flowering plants and also the very latest flowering plants in the fall.

The best species and varieties of this most charming genus come to our gardens from the mountains of Asia Minor. We are very much indebted to Mr. Edward Whittall of Smyrna for first collecting and introducing the best varieties to cultivation. Indeed he not only collected *Chionodoxas* but many other useful plants from the high mountains of Asia Minor. A few of the choicest are *Sternbergia macrantha*, a variety of *Fritillaria aurea*, *Fritillaria Whittallii*, *Crocus Tauri*, and *Galanthus Ikaraci*.

The nomenclature of the species and varieties is rather mixed up. In an article Mr. Whittall wrote several years ago he says that *Chionodoxa Luciliae* is only found on the Nymph Dagh range of mountains beginning from the heights of Taliiti above Smyrna and ending with those above the village of Nymphio. In the wild state, he says, the pink and white varieties of *Luciliae* are charming plants.

The first variety Mr. Whittall discovered was *Sardensis*, finding it on the Mahmood Dagh, from which one can see by looking in an easterly direction the plains of Sardis. In its wild state the most distinctive features of this plant are its deeper and almost entirely porcelain blue petals and small white eye. There are white and pink forms in the wild state but not so pretty as those of *Luciliae*.

The variety *gigantea* was named by Mr. Whittall on account of the very large size of the flowers and it

also differs materially from *Luciliae* and *Sardensis* in color. The white and pink forms are very handsome.

Tmolusii is found on the Tmolus range of mountains and on that account received its name. It is dwarfer than *Luciliae* or *Sardensis* but more free flowering and more brilliant in color. Its white eye is larger than in *Luciliae* and the points of the petals more vivid than in *Sardensis*.

The variety *Alleni* was also discovered and introduced by Mr. Whittall and is said to be a natural hybrid of *Scilla bifolia* and *Chionodoxa Luciliae*.

In the Kew Hand-list of plants the nomenclature of *Luciliae* is given as follows:

<i>Chionodoxa Luciliae</i> ,	Boiss.
"	Var. <i>Alleni</i> .
"	Var. <i>gigantea</i> .
"	Var. <i>Sardensis</i> .
"	Var. <i>Tmolusii</i> .

These bulbs coming from the high mountains of Asia Minor are as hardy as any of our native plants and can be planted in any situation. They are low growing and clumps in the front of the herbaceous border are exceptionally fine now. In the rock garden they are perfectly at home and are a blaze of color. The two species *cretica* and *nana* are not as showy or yet as good garden plants as the above kinds.

Let us plant more of these spring harbingers and make this world better and happier to live in. Some one has said that flowers preach to us if we would only allow them. This is true; they preach most wonderful and interesting discourses to some of us.



British Horticulture

THE MIDLAND DAFFODIL SHOW

The unfavorable spring which has been experienced in this country militated against the complete success of the annual show of the Midland Daffodil Society as regards the number of exhibits. There was an interesting display of novelties, awards being made to the following: *Narcissus Buttercup*, a medium-sized deep self flower of the *magni-coronati* type; exhibited by C. Dawson. *N. Chloe*, another of the *magni-coronati* type, a shapely bloom, with a broad, cream colored perianth, and a soft canary or pale yellow cup; exhibited by T. Bateson. *Saxifraga*, Ditton seedling, a neat plant, with deep crimson flowers; exhibited by Messrs. Barr & Sons. *Viola gracilis*, bearing clusters of small, violet blue flowers; exhibited by R. Wallace & Co. The Cartwright Challenge Cup, which was offered for 12 varieties of daffodils which have not been in commerce for a longer period than four years, was won by E. M. Crofield, who staged some good specimens of *Malaga*, *Lolah*, *Tiara*, *Penguin*, *Arhelta*, *Stay Sail*, *Mrs. Ernest Crofield*, *Radiant*, *Giraffe*, *Phantasy*, *Makeshift* and *Potent*. The Bourne Memorial Challenge Cup was won by P. D. Williams. At the formal opening Robert Sydenham, who has labored so zealously in the interests of the society, was presented with a handsome illuminated album, Mrs. Sydenham receiving a massive silver candelabra. Mrs. H. Smith, one of the honorable Secretaries, was the recipient of a silver tea service and a purse of gold.



NEWS OF THE CLUBS AND SOCIETIES.

GARDENERS' AND FLORISTS' CLUB OF BOSTON.

A few thoughts on the art of selling was the topic of a thoughtful paper read at the meeting of this club on Tuesday evening, May 9. Out of the discussion of the paper was evolved a little shy at the old vexed question as to which of the two interests grower or retailer was responsible for the various grievances that afflict the cut-flower business such as surpluses, overstock, excessive prices and cut rates. As usual a large proportion of the members present were gardeners employed on private places, but they seemed to be as intensely interested in the subject as their commercial brothers and were enthusiastic in their applause when any of the contestants scored a point in the debate. Robert Cameron was responsible for the turn taken in the discussion by naively inquiring whether a business man is a truthful man. The fine points of difference between expediency and *bona fides* were skillfully covered by Mr. Palmer in his reply, and then W. H. Elliott, Eber Holmes, W. J. Kennedy, P. Welch and several others became severally involved in the problem of how far defective salesmanship might be held responsible for the periods of overstock that afflict the trade at times.

Mr. Palmer allowed that if a better feeling of co-operation existed between the grower and the retailer there would be no such thing as overproduction and no desire to corner the market or withhold stock for the purpose of advancing prices. Mr. Elliott thought the remedy for gluts would be found in giving the public better information as to prevailing conditions when heavy crops were on, and letting them have access to the low values. The policy of the retail trade as to prices was not conducive to the moving of the overstock, especially as it is carried on in Boston, and he instanced Chicago as handling this problem much better than Boston. Mr. Kennedy thought it might be a good thing to open the wholesale markets to retail trade after a certain hour each day.

Mr. Holmes voiced an appreciative tribute to Mr. Palmer whom he had in former years found to be the personification of an ideal employer.

The exhibits on the platform included four vases of seedling carnations from M. A. Patten, a "rose-pink" sport of Enchantress from Wm. Swan, a very pretty seedling marguerite from F. W. Fletcher, late single tulip Sara Bernhardt from W. W. Rawson & Co., and some roses, including two fuel-flowered pot plants of Liberty, from Eber Holmes.

NEW HAVEN COUNTY HORTICULTURAL SOCIETY.

A meeting of the above society was held on May 19, with a large gathering present. John Girard of New Britain gave an instructive paper on pansies. He had about 100 fine blooms on exhibition, for which he was awarded a cultural certificate. The society will hold a Rose Show in their hall on June 16th.

SOCIETY OF AMERICAN FLORISTS AND ORNAMENTAL HORTICULTURISTS.

Appointment of Vice-President.

President Traendly has appointed Mr. John L. Parker of Birmingham, Alabama, as State Vice-President for his State.

Census Committee.

President Traendly has appointed Messrs. P. O'Mara, Jersey City, New Jersey; J. A. Valentine, Denver, Colo., and Albert T. Hey, Springfield, Ill., as a committee to cooperate and advise with the Census Department regarding matters relating to ornamental horticulture in the approaching U. S. Census. W. N. RUDD, Secretary.

BUFFALO FLORISTS' CLUB.

At a special meeting of the Buffalo Florists' Club held May 20, the sad news of the death of Mr. Wm. Scott on May 19 was imparted to the members. A resolution was adopted conveying to the family its sincere sympathy in their loss, stating that whereas Mr. Scott was well known and highly esteemed by the florists of Buffalo and the surrounding country, it is with profound sorrow that we have learned of his death.

The country has lost a sincere lover of our profession and an enthusiast in his chosen field. Our heartfelt sympathy goes out to his bereaved widow and children in this hour of their sorrow. Words are of little avail in these days, but to the fatherless and widow it may be a ray of pleasure to be assured that through the length and breadth of this adopted country the name of William Scott commands only respect and affection.

Resolved that a copy of the resolutions be sent to the bereaved family and spread on the minutes of the society.

Signed:

CHAS. SANDFORD, Pres.
E. C. BRÜCKER, Fin. Sec'y.

ST. LOUIS FLORISTS' CLUB.

The regular monthly meeting of this club took place on last Thursday afternoon in Bowman Hall. The meeting was very poorly attended, the busy planting season being no doubt responsible. In the absence of President Young, Vice-President Augermüller opened the meeting and J. J. Benke acted for Secretary Bentzen. None of the potterly committee being on hand to make a report and the time being up in which to complete the \$10,000 subscription in which they failed the committee was discharged with thanks. In discussing a suitable place for the summer outing, the one most favorably received was the White City Amusement Garden near Belleville, Ill., and upon invitation of A. S. Halsted the trustees and Mr. Halsted will visit the place next week.

Most of the afternoon was taken up with a talk on Easter business and discussions on club matters. Next meeting takes place Thursday afternoon, June 11, at 2 o'clock.

PENNSYLVANIA HORTICULTURAL SOCIETY.

There was a fine display of flowering tulips at the monthly meeting of this society held on the 19th inst. Joseph Hurly, gardener for James W. Paul, Jr., took first with a choice collection. Samuel Batchelor, gardener to Clement B. Newbold, second. M. Batchelor also had a fine collection of perennials, for which he was awarded a special prize. The Michell prizes for lettuce seed went to Samuel Hammond and John McLeary. Joseph Hurley, Thos. Logan, Xavier Schmitt, W. Robertson, and Frank Gould were appointed a committee to fix the date of the rose and peony show, and will make final decision 8 P. M. 26th. Many valuable prizes are offered for this event. A discussion took place on peony nomenclature and a vote was passed instructing the judges to give preference to the most correctly named collections.

AMERICAN ASSOCIATION OF PARK SUPERINTENDENTS.

The next annual meeting of this organization will be held at West Hotel, Minneapolis, Minn., on August 11, 12, 13 and 14. Visits to the park system of St. Paul and Minneapolis will occupy a good portion of the time and on the last day a trip to Lake Minnetonka is proposed. Valuable papers on practical topics will be presented by members.

CLUB AND SOCIETY NOTES.

The Florists' Club of Springfield, Ill., have decided to hold a flower show in November, but the date is not yet fixed.

The first flower show of the Woman's Club of Hollywood Cal., held on April 30, was a great success. Howard & Smith, J. M. Leibold, E. B. Sturtevant, E. H. Rust, John Murietta, the Arthur Leets and the Bartlett estates, all contributed liberally. Field-grown carnations were largely in evidence.

The preliminary schedule of the eighth annual exhibition of the New Haven County (Conn.) Horticultural Society has been issued. The dates of the exhibition are November 10, 11, 12, 1908. Copies of the schedule may be had on application to the secretary, Walter Koella, 58 Bishop street, New Haven, Conn.

A NEW ORNAMENTAL GRASS.

Paspalum distichum variegatum is mentioned in the Journal of Horticulture of Australasia as a new ornamental grass, valuable for use in hanging baskets, etc. According to Gray, *Paspalum distichum* is a native of Virginia and southward in the United States where it is found in wet fields and is known as "joint grass." The origin of this variegated form, which is an introduction of 1908, is not given in the note referred to but the plant is described as green and white or yellow with pink or red edge.

Memorial Day

BIGGEST FLORAL HOLIDAY OF THE YEAR

WE are now booking shipping orders and if you will place them early we will fill them.

We offer a splendid stock of **Beauty, Kaiserin, Carnot, Bridesmaid, Bride, Killarney, Richmond and Chatenay Roses. Carnations, Stocks, Spiræa, Lilies, Sweet Peas, Lily of the Valley, Late Tulips, Lilacs, Cape Jessamines, etc., etc.** Also **Hardy Ferns, New Crop.**

LOWEST PRICES ON Letters, Emblems, Inscriptions, Folding Boxes, Wire Frames, Ribbons and other Florists' Supplies in complete assortment.

Welch Brothers

City Hall Cut Flower Market

226 Devonshire St., BOSTON

A FEW THOUGHTS ON THE ART OF SELLING.

(A paper read before the Gardeners' and Florists' Club of Boston by F. E. Palmer.)

The important, in fact the fundamental element in a successful sale, is that it should be of advantage, or profit, to both parties. This simple proposition has, I fear, an unimportant place in the mind of the average salesman; it is nevertheless true and should be made the basis of every transaction between man and man. Any exchange of services which necessarily involves loss to either party cannot be called legitimate business.

A second basic principle in all commerce, and one that should be understood by both buyer and seller, is that demand precedes supply.

In the process of evolution from the simple barter of goods between our forefathers to the complexities of trade in modern civilization, the above two axiomatic truths have become somewhat obscured. Derangements have also crept into the body politic which have aggravated the confusion, and reversed the natural order of things until the man who sells has come to be looked upon as the obsequious servant of him who buys. This attitude has become by custom so much a second nature that we take it for granted the seller is always under obligation to the buyer, and that labor shall forever bow the knee to capital. Volumes have been written, and more doubtless will be, on this important phase of economics before the subject is exhausted, and no more fruitful study could possibly invite the consideration of business men, especially salesmen.

Consistently with the above principles, the relationship between buyer and seller should be entirely of a friendly nature, and the appreciation of this fact constitutes the primary lesson in the art of selling.

In some simple kinds of trade little is required of the salesman but to hand over the article called for and take the amount determined upon as payment. In such cases little special knowledge is required and certainly no determination of values. When, however, it comes to the selling of flowers, plants, seeds, shrubs and trees, the supplying of decorative schemes—from the simple bunch destined to cheer a sick friend to the elaborate display for ball room or dinner table—the simple potted plant or the varied collection for the garden, the mysterious seed package, or equally doubtful dormant tree and shrub, then the salesman comes in touch with one of the higher requirements of humanity and the satisfying of these aesthetic needs becomes indeed a fine art. In such cases how many elements can enter into a sale, possibly every one of which may have to be supplied by the intelligent salesman! Most likely the purchaser has a very vague picture in mind as to what he wants, also an equal uncertainty as to the amount to be expended. Imagine a customer in such a frame of mind, also somewhat fastidious of taste and exacting in requirements, and it will readily be seen that a very different problem is presented than in most other commercial transactions.

Perhaps the first requirement of a salesman will be that delicate tact which makes his patron feel at ease, and will so gracefully convey infor-

mation—or correct an error—that not the slightest sting of confusion or mortification will be felt. This trait in a salesman, or in fact in any man, is one of the rarest assets. Next to tact comes enthusiasm, that earnest spirit of service which quickly discovers the customer's needs, cheerfully gives information, evinces a willingness to show every flower in the place if necessary and is never tired out. This quality is as rare as tact and generally goes with it, perhaps being born in a man rather than acquired. Add to these the ability to arrange the flowers artistically so that a very common thing may become one of beauty, to deftly and rapidly pack and tie the box in order that the flowers may not suffer, and the time—which up to this point has been used to advantage—may not be wasted on mere details.

It is easy to conceive, as the customer is courteously dismissed, the satisfying effect that all this intelligent effort has upon him. Not only has he been educated and pleased, but the value of a simple dozen of roses has been enhanced in his eyes possibly one hundred fold. In this way a value has been created and credit has redounded both to the house and to the salesman.

Stress has been laid on the philosophical side of the art of selling rather than on its material and technical aspect. This is because of the firm belief that the qualities mentioned, besides conducing to the elevation of the florists' and other kindred businesses, have an immediate and cash value, and that higher ideals will ultimately prevail in trade relations. Indeed the day of the "Deaconing" of the apple barrel, the sanding of sugar, watering of milk, "salting down" of flowers, and

general misrepresenting of goods is happily passing away.

Perhaps the following epitome will serve to convey the writer's thoughts in a pointed and more easily remembered form:

It is not such a good practice to "sneak" a customer as to satisfy him.

It is better to size him up as to his needs rather than as to his ability to pay a big price.

It is more to the advantage of both parties that good, fresh stock be sold than to entertain the delusion that a customer will come oftener if the goods perish quickly.

Common decency dictates that equal courtesy be extended to every patron regardless of the size of his pocket-book.

Success depends more on absolute reliability than on glib tongue and a plausible story.

It is taken for granted that a salesman should be well informed on the technical and scientific details of his business, although this knowledge has been lamentably absent in the florist's trade.

Selling a certain line of goods at, or below, cost as a "leader" to attract the public is not legitimate business, the object being to mislead buyers into the belief that all other goods in the store are equally low-priced.

Any other action having as its prime object the ruin of a competitor is pernicious.

The giving away of flowers is no part of selling and should be charged up to advertising.

Finally, to one desirous of perfecting himself in the art of selling no better lesson can be learned than from a careful study of his own experiences as a buyer. It is safe to say that he will find himself attracted by the cordial friendly greeting, especially if his name be remembered, the prompt offer of service, and the manifest truthfulness of all information given.

SOME AZALEA AWARDS AT GHENT.

The following awards were received by August Haerens, of Somergem, Belgium, at the recent quinquennial exhibition in Ghent:

First prize for group of Azalea indica of all shapes and sizes, occupying 50 square meters, by acclamation of the jury. Over 300 plants were used in the group.

First prize (gold medal) for group of 50 azaleas, fan shape, with special commendation of the jury. Group was admired by everyone.

First prize (gilt medal) for 25 Azalea Vervaeckiana alba.

First prize (gilt medal) for the finest specimen azalea (plante de culture).

First prize (gold medal) for the 12 newest specimen azaleas.

Second prize (gold medal) for 100 new azaleas, and second prize (silver medal) for six new azaleas.

As to the fan-shaped azaleas, Messrs. Haerens think it is strange that they find so little favor in America, while on the Continent everyone likes them at sight. Naturally, they cannot be cheap, as they require too much care and labor, and take up as much house-room as do the pyramids. Mr. Haerens intends to go ahead with them and grow from 300 to 500 every year.

Obituary

William Scott.

Although not unexpected by the many friends who have followed the course of William Scott's long illness, the news of his death, at his home in Buffalo, N. Y., on Tuesday, May 19, will, we doubt not, come as a painful shock to every community where his genial personality was known. And it is no exaggeration to say that wherever there was a florist anywhere on this continent, William Scott was known.

Mr. Scott was born July 31st, 1844, at Leigh Park, Hampshire, England, the country home of Sir George Thomas Staunton, one of the finest gardens in Europe, where his father was head gardener for 27 years. He attended a private school in the neighboring town of Havant till he was 13 years of age, at which time the schoolmaster became insane, but Mr. Scott said this was not his fault. He began work in the garden shortly after this, and at 15 years of age he had the care



WILLIAM SCOTT

of a conservatory that had to be so scrupulously clean and neat that the petal of a carnation must not be seen on the snow-white paths or the trim kept border. When the subject of this sketch was 17 years of age, his father removed to Chichester, where he rented the Northgate Nurseries. Mr. Scott worked in the nursery, greenhouses and seed store of his father till the spring of 1868 except for two years, during which he was employed in the seed store of W. H. Rogers, of Southampton. In the spring of 1868 a spirit of adventure came over the young man, his brother and his friend, Mr. E. I. Mopsted, James Fleming, then in partnership with Peter Henderson, was one of the old Leigh Park men. Mr. Eust of Philadelphia, and Mr. Brackenridge of Baltimore, were old associates of the elder Scott in Edinboro. David Ferguson of Philadelphia was another Leigh Park man, and there were others in the United States. The watering pot was thrown down one night in March with the expectation that it was never to be handled again, and the trio were off for the

backwoods of Canada to trap and hunt and get in close communion with red men of the primeval forest. The look of the forest about three miles up Yonge Street, Toronto, was enough for the party, and through the kindness of George Leslie, a well-known nursery man, the party was quickly back at the old trade. The following winter Mr. Scott was in the employ of James Pape, who grew plants for the Toronto market. The summer of 1869 they tried market gardening and the seed business in Stratford, Ont. There were too many in the firm, and so Mr. Scott engaged with Mr. Geo. Bailey of Buffalo, crossing the Niagara river under conditions which would now be a direct violation of the contract labor law, but in this case low price was not the motive for importing a foreigner, for he received good wages. Two years later he rented this place for commercial use. Two years later he secured the property on Balcom street, which is still in the hands of his family.

What Mr. Scott has done for his fellow craftsmen through his contributions to the trade press is well known to most of our readers. He had the happy faculty of expressing himself readily in a most entertaining and graceful manner, and was never at a loss to secure eager listeners when he spoke or readers when he wrote. He took an active interest in the Society of American Florists and at the Pittsburgh convention in 1895 was elected president of that organization, presiding at the convention in Cleveland the following year.

Mr. Scott was married 39 years ago to Miss Christine Frick. He is survived by six sons and one daughter, Helen, Robert, Alexander, William, Jr., Oliver, David and Philip.

Thomas Green.

Thomas Green, who for many years was the only florist in Joplin, Mo., died on May 3 at the age of 87. He came to the United States in 1867 and has resided in Joplin for thirty-one years.

G. W. Spinney.

Gustavus W. Spinney, who for many years was engaged in the nursery business, died at his home in Georgetown, Mass., on May 12, at the age of 68. A widow and two daughters survive him.

LES BIBLIOTHEQUES HORTICOLES.

Under the above heading our correspondent, Mr. Harman Payne, makes some pertinent remarks in "La Tribune Horticole" of Brussels for the 28 March on the subject of Horticultural Libraries. Comparisons are made between the Lindley Library, attached to the Royal Horticultural Society of London, the Massachusetts Horticultural Society Library and the Library of the National Horticultural Society of France, to what is evidently the manifest advantage of the two latter. In spite of the great progress of the English Royal Horticultural Society there is evidently some room for advance to be made in connection with the Lindley Library which is not considered by our correspondent, himself a well known book collector, to be adequate to the requirements of horticultural library workers in England.

Order Now and Order From Us



For MEMORIAL DAY



Orders given in time have always been filled complete by us. No disappointment.

NEW CROP

Dagger and Fancy Ferns

\$2.00 per 1000

LAUREL WREATHS, \$2.50 to \$3.00 doz.
FESTOONING, - - - 6c a yard.

BEST QUALITY

Galax Leaves, Bronze and Green

\$1.00 per 1000 \$8.50 per 10,000

BOXWOOD, 20c per pound.

Cut Flower Department

We can fill orders for all varieties of Outdoor and Indoor Memorial Day Flowers. All grades from ordinary up to choicest, at fair prices. Don't forget the name.

HENRY M. ROBINSON & CO., BOSTON
15 PROVINCE ST., and 9 CHAPMAN PL.

PARIS CHRYSANTHEMUM SHOW.

At the next November show of the National Horticultural Society of France an innovation of an interesting character will be attempted. A portion of the show will be set apart for exhibits relating to the library and artistic features of the chrysanthemums and a preliminary announcement to enable exhibitors to get ready has just been issued. The new section will be divided into two divisions, the first being for exhibits of books, publications, prints, engravings, pictures and old catalogues relating to the chrysanthemum, and the second being for old varieties in cultivation anterior to the year 1896.

This resolve is undoubtedly the outcome of a very interesting exhibit by the society's librarian at the last show when he staged in glass cases a series of colored engravings of old chrysanthemums and books from the society's library which excited no little interest on the part of members and visitors. It is probable too, that Mr. Harman Payne's recently published Bibliography of the Chrysanthemum, which was written for and at the request of the chrysanthemum committee of the French society, has also been a factor in the case. We shall look forward with some degree of curiosity to the result of this somewhat novel and educational attempt on the part of the great French Horticultural Society.

You will find something worth reading on every page of HORTICULTURE.

HARTFORD'S NEW SUPERINTENDENT OF STREETS.

In electing Alexander Cumming as superintendent of streets, the street board has obtained a man for the head of its working department who has had long experience in work best suiting him for his new position and



ALEXANDER CUMMING

which, it is believed, will have much influence on his success as superintendent.

Mr. Cumming is a native of Ayrshire, Scotland, and came to this country in 1890, locating in Toronto, where he had charge of extensive improve-

ments on the government lands, having complete direction of the construction of new roads, boulevards and walks, extensive planting of trees and the laying out and grading of the Military Cemetery. He was employed in the Toronto parks in similar work and still later went to Philadelphia, where he became superintendent of Stoke Pogis, a large suburban tract which was being developed. He came to Hartford four years ago to become park forester, an office which was changed to that of city forester a year ago and which he has continued to fill with great efficiency.—Hartford Courant, May 8th.

We congratulate the people of Hartford in getting so good a man as Mr. Cumming for their superintendent of streets. In this instance it is emphatically a case of the office seeking the man. Some friendly pressure and the higher salary were no doubt the temptations that induced Mr. Cumming to leave, for a time at least, his life-long profession of gardening and forestry.

ROCHEA FALCATA.

Paul Kuhne in Moller's Deutsche Gartner Zeitung.

Through long culture I have succeeded in reducing the height of this plant so much that it now has become a desirable market plant. Rocheas cannot stand the moist airs in autumn, sunlight and always sunlight is the main requirement for Rocheas. If we pay attention to sufficient nourishment during the flowering period the plant will give a glorious flower head, which will compare in beauty with any other market plant, and will last a long time.

PALMS Home Grown.

ARECA LUTESCENS

Each	Doz.
6-in. pot, 3 plants, 24 to 26 in. high	\$12.00 \$12.00
7-in. pot, 3 plants, 30 to 32 in. high	24.00 24.00
8-in. pot, 3 plants, 36 to 40 in. high	36.00 36.00

COCOS WEDDELLIANA

2½ in. pot, 8 to 10 in. high	15
3½ in. pot, 10 to 12 in. high	15

KENTIA FORSTERIANA

9-in. tub, 4 plants, 4 ft. high, heavy	60.00
--	-------

KENTIA BELMOREANA

Each	Doz.
6-in. pot, 6 to 7 leaves, 22 to 24 in.	\$1.00 \$12.00
6-in. pot, 6 to 7 leaves, 24 to 26 in.	1.25 15.00
6-in. pot, 6 to 7 leaves, 26 to 28 in.	1.50 18.00
6-in. pot, 6 to 7 leaves, 30 to 36 in.	2.00 24.00
7-in. pot, 6 to 7 leaves, 32 to 34 in.	
heavy	2.50 30.00
9-in. tub, 6 to 7 leaves, 42 to 48 in.	
heavy	5.00 60.00

JOSEPH HEACOCK COMPANY, Wyncote, Pa.

BAY STATE

The big sensation of all the recent Carnation Shows. A noble flower, white with carmine markings.

Now Booking Orders for Next January Delivery.

Rooted Cuttings, \$12.00 per 100, \$100.00 per 1000

ALBERT ROPER, Tewkesbury, Mass.

Gardenias, 5 in., \$15.00 per 100

FOR CASH TO CLEAR

THE TRUE VEITCHI — The only one to grow under glass for forcing.

WM. GRAHAM CO., - David Rust, Receiver

104 SOUTH 13th STREET, PHILADELPHIA. Greenhouses at Logan

COLEUS

Verschaffelii, Golden Queen, Fire Brand, Lord Palmerston, Queen Victoria, Beckwith's Gem. Prices of Rooted Cuttings by express, 60c. per 100; \$5 per 1000. Less than 250 of a variety will be charged at the 100 rate.

Golden Bedder, Hero, Lessey, Pearl of Orange. 75c. per 100; \$6 per 1000. Less than 250 of a variety will be charged at the 100 rate.

Fancy Varieties. A very fine assortment of twelve kinds not listed above. 75c. per 100; \$6 per 1000. 250, in assortment, our selection, at the 1000 rate.

MISCELLANEOUS PLANTS

AGERATUM, Stella Gurney, Princess Pauline. SALVIA Splendens, Bonfire. HELIOTROPE. Rooted cuttings, 75c. per 100; \$6 per 1000.

CARNATIONS

Rooted Cuttings	100	1000
Winsor	\$6.00	\$50.00
White Perfection	2.50	20.00
Rose Pink Enchantress	3.50	30.00
Enchantress	2.50	20.00
Queen Louise	2.50	20.00

From 2½ inch pots, add \$1.00 per 100.

ASPARAGUS PLUMOSUS MANUS SEEDLINGS From flats, \$1.00 per 1000.

CHRYSANTHEMUMS

Standard varieties, ready for shipment. Rooted cuttings, \$2 per 100; \$15 per 1000. Send for list.

A. N. PIERSON, CROMWELL, CONN.

Begonia Gloire de Lorraine

Strong 2½ in. pot plants, leaf cuttings, \$15 per 100, \$140 per 1000. Early June delivery or NOW if wanted.

S. S. SKIDELSKY, 1741 No. 18th St. PHILADELPHIA

DAHLIAS.

Now is the time to place your order for bulbs which will insure you getting named varieties in any quantity; prompt delivery.

DAVID HERBERT & SON,

Successors to L. K. Peacock, Inc. ATCO, N. J.

FIRST CLASS STOCK

100,000 GERANIUMS, bushy, excellent, strong plants in bud and bloom, DBL. GRANT, POITEVINE, BUCHNER, CASTELLANE, ROSE, 3½-4 inch, \$4.50 per 100, \$40.00 per 1000. 3 inch \$3.00 Not in bloom \$2.50 \$3.50 per 100. 100,000 COLEUS, 12 varieties, strong 2 inch, \$1.50 per 100, \$14.00 per 1000, strong 3 inch, \$2.50 per 100, \$20.00 per 1000. SALVIA BONFIRE and SPL., strong 3 inch, \$2.50, 4 inch \$4.00 per 100. Lobelias and Verbenas in bud and bloom, strong 2 inch \$1.50, strong 3 inch, \$2.50 per 100, cash. Money back if not satisfactory.

WM. S. HERZOG, Morris Plains, N. J.

CARNATIONS

F. DORNER & SONS CO.

La Fayette, Ind.

ROOTED

CARNATION CUTTINGS

Only the Best Varieties

CHICAGO CARNATION CO., JOLIET ILL.

SOMETHING GOOD

FOR SMALL PRICE

3000 2-1-2 in. Salvia Splendens	\$2.00 per 100
1000 Enchantress Carnations	2.00 "
1000 Prosperity	2.00 "
500 Winsor	6.00 "

Very strong transplanted Asters, sure to please, at 60c per 100.

COHANZIE CARNATION GREENHOUSES, New London, Conn.

JOHN E. HAINES Bethlehem, Pa.

is the place to order rooted-cuttings of the following varieties for 1908.

John E. Haines, red	Per 100	Per 1000
Imperial variegated		
Pink Imperial, Pink	\$6.00	\$50.00
Enchantress, Light Pink		

Place your orders early for Jan. delivery.

Like the Bee so is Godfrey Aschmann, the Philadelphia Hustler, Never Idle

If you are in market for Bedding Plants GRAB THIS BARGAIN now offered for Decoration Day.

Geraniums, S. A. Nutt, John Doyle and assorted varieties, 4-in. pots, per 100, \$7.00.

Agerat m, dwarf blue, 4-in., per 100, \$7.00.

Begonia Vernon, the best dark red varieties, and the fine improved Erfordi, the ever-blooming variety of Europe, 4-in., per 100, \$8.00; 3-in., per 100, \$6.00.

Scarlet Sage, the true Bonfire or Clara Bedman, 4-in., \$8.00.

Heliotrope, 4-in., per 100, \$7.00.

Fuchsias, best varieties, 4-in., \$7.00 to \$8.00 per 100.

Ivy, English or Hardy, staked up, 3 feet high, 4-in., per 100, \$12.00.

Vinca Variegata, 4-in., per 100, \$10.00; 2½-in., \$4.00.

Cobaea Scandens, 4-in., staked up, per 100, \$10.00.

Geraniums, Mine, Salleroi, for borders, strong plants, per 100, \$4.00.

Phlox Drummondii Grandiflora, 2½ to 3-in., per 100, \$3.00.

Cuphea or Cigar Plants, 2½-in., per 100, \$3.00.

Lobelia, Dwarf and Trailing, 2½-in., per 100, \$3.00.

Tradescantia, 2 best varieties, 2½-in., per 100, \$3.00.

Parlor or German Ivy, 2½-in., per 100, \$4.00.

Ground Ivy, 2½-in., per 100, \$4.00.

Verbenas, best strain, all colors, 2½-in., per 100, \$3.00.

Sweet Alyssum, Little Gem or Carpet of Snow, 2½-in., per 100, \$3.00.

Summer Chrysanthemums, 3-in., best kinds, per 100, \$4.00.

Nasturtiums, best dwarf, all colors, 3-in., per 100, \$4.00.

Centauria Gymnocarpa, Dusty Miller, 2½-in., per 100, \$3.00.

Torenia Fournieri, 2½-in., per 100, \$3.00.

Kentworth Ivy, 2½ in., per 100, \$3.00.

Petunias, California Giant, 3-in., per 100, \$5.00; Inimitable or dwarf, 2½ to 3-in., per 100, \$3.00.

Marigolds or Tagetes, Eldorado, Gold Ring, 3 in., per 100, \$4.00.

Best French Cannas, about 12 superior colors, by name, very strong plants, 4-in., per 100, \$7.00 to \$8.00.

Clematis Jackmanni, late fall importation, 3 ft. high, nicely staked up, 35 to 40c.

Hybrid Roses, budded stock, late fall importation, Hermosa, 2½ to 3 feet high, Magna Charta, Paul Neyron, Mrs. John Laing, Jacqueminot, etc., Baby Rambler, 5½ to 6-in. pots, 25 to 35c.

Araucaria Excelsa Glauca, 6 to 7-in. pots, last spring (1907) importation, 3 tiers, 25 to 40 inches high, same in width, 6 year old, suitable for lawns and parks, \$1.75, \$2.00, \$2.50, \$3.00, \$4.00 each.

Imported two weeks ago 5000 Araucaria Excelsa, 3 tiers, 6-8-10-in. high, 40c; 10-12-14-in., 50c, 60c, 75c, \$1.00 each.

Kentia Belmoreana, 5½ in., 20-25 inches high, 50c, 60c, 4 in., 35c. Forsteriana, large plants, \$2.50 each.

Cash with order, please. All goods must travel at purchaser's risk

Godfrey Aschmann

Importer, Wholesale Grower and Shipper of Pot Plants

1012 West Ontario St. Philadelphia, Pa.

ROBERT CRAIG CO.

ROSES, PALMS,

and Novelties in Decorative Plants

MARKET and 49th STREETS., PHILADELPHIA, PA.

ROSES

Strong, Clean Stock. Grafted, Killarney, Richmond, Brides and Maids. \$12.00 per 100, \$110.00 per 1000.

Own Roots, Brides, Maids, Gates, Ivory, Perle, Killarney and Richmond. \$6.00 per 100, \$55 per 1000. All from 3½ in. pots.

P. R. QUINLAN, Syracuse, N. Y.

CANNAS

Strong plants from pots. 40 leading varieties, \$5.00 per 100.

ESTATE OF DAVID FISHER, WOBURN, MASS.

A BARCAIN FOR YOU

ROSES Etoile de France, 1400, 3 1/2 and 4 inch propagated last Spring from grafted stock, \$6.00 per 100. 700 in 6 and 7 inch pots, strong grafted plants, \$25.00 per 100.

Killarney, 700 3 1/2 and 4 inch grafted on English Manetti, strong and vigorous, \$12.00 per 100. 350 each **Bride** and **Bridesmaid** 4 inch, price on application.

BOUVARDIA 600 4 inch pots of the popular white Bouvardia Humboldtii. Also 3000 strong roots from boxes. Price on application.

ANDERSON & WILLIAMS
WALTHAM, MASS.

GERANIUMS

A Large Assortment of the Choicest Kinds.

From 3 1/2 in. pots, \$7.00 and \$8.00 per 100.

FOR DECORATION DAY

40,000 LILIES, \$8.00, \$10.00 and \$12.50 per hundred.
25,000 SPIRAEA (cut), \$2.00 to \$4.00 per hundred.
HYDRANGEAS, 50c to \$5.00 each.

WM. W. EDGAR CO.,
Waverley, - - - Mass.

GERANIUMS

A CORDIAL invitation is extended to all interested in Geraniums to visit us during May and June, to inspect our new stock houses containing over 60,000 plants, and especially to see our new show house; in it there are over 300 varieties in full bloom; a splendid opportunity to compare the newer introductions with the old standards, and to select stock for next season. We will make very liberal special prices on all orders booked during May and June for December delivery. We are at Cowenton on the B. & O. R. R., and at Chase on the Pennsy. We meet all trains.

DAHLIA ROOTS Whole field clumps, at \$5.00 per 100 and up; send for list of 75 varieties.

HARDY CHRYSANTHEMUMS A splendid collection of the very best 75 varieties, Small Flowered or Button \$2.00 per 100. Large Flowered or Aster type \$3.00 per 100.

DAHLIA PLANTS From 2-in. pots, ready for immediate shipment at \$2.00 per 100 and up. We will send 1000 in 20 good varieties, our selection, for \$18.50.

PELARGONIUMS In good variety, 3-in pots, \$1.50 per dozen, \$6.00 per 100.

Ageratum , Stella Gurney.....	Per 100	Hollyhocks , Strong 3 in. pot plants, dbl. white, pink, red and yellow.....	Per 100
Begonia , Vernon, White and Rose.....	\$2.00		3.00
" Gracilis, White and Rose.....	2.00	Ivy Leaved Geraniums , 6 good kinds, \$25.00 per 1000.....	3.00
Coleus , Verschaffeltii, Golden Bedder and other kinds.....	2.00	Lobelia , Crystal Palace Gem.....	2.00
Fuchsias , Black Prince and Minnesota..	2.00	" Kathleen Mallard, 2 inch.....	3.00
Lieutenant Muritz, White and Rose Phenomenal.....	2.50	Lavender , 2 1/2 in. pots strong.....	3.00
Hardy English Ivy , Extra Strong. \$15.00 per 1000.....	2.00	Swainsona , Alba.....	2.00
Hardy Phlox	2.00	Tradescantia , Dark Variegated.....	2.00
		Verbena , Red, White, Purple and Pink.....	2.00

R. VINCENT JR. & SONS COMPANY, White Marsh, Md.

TUBEROSES

EXCELSIOR DWARF PEARL 3 x 4 - \$.60 per 100, \$5.00 per 1000
4 x 6 - 1.00 per 100, 8.00 per 1000

STUMPP & WALTER CO., 50 Barclay Street, NEW YORK

A HALF MILLION CALLA BULBS FOR SALE

CALLA ETHIOPICA BULBS, 7 to 8 inch circumference, \$65.00 per 1000
" " " 5 to 7 " " 40.00 " "
" " " 3 to 5 " " 25.00 "

250 at 1000 Rates, Freight Prepaid when Cash is sent with Order. Orders booked now for July shipments.

A. MITTINC, 17 to 23 Kennan St., Santa Cruz, Cal.

CANNAS

Send for our List and Prices

The CONARD & JONES CO.
WEST GROVE, PA.

Established 40 Years

Rose Hill Nurseries

New and Rare Plants

NEW ROCHELLE, N. Y.

New York Office, Siebrocht Building, 425 Fifth Avenue

Bedding Plants

All Kinds, Stocky, Good Size, Low Price. Can supply the Trade in quantity.

Just Received

A big shipment of ARAUCARIAS, PALMS, etc. Orders taken now for import for fall delivery.

A LEUTHY, & CO.

PERKINS ST. NURSERIES
ROSLINDALE, MASS.

Dracena Indivisa, \$2 and \$5 per doz.
Vinca var. \$1.50 and \$2 per doz.
Canna Robusta, dark leaf, tall from flats, \$3 per C.
Cannas, dark and green leaf, dwarf from flats, \$3 per C.

E. & C. Woodman, Florists, Danvers, Mass.
TELEPHONE, 4106-2 DANVERS, MASS.

Gloire de Lorraine Begonia

2 1/4 inch pots, \$15.00 per 100
\$140.00 per 1000

Thomas Roland
Nahant - - - Mass.

In ordering goods please add "I saw it in HORTICULTURE."

Ipomoea Noctiflora

Best pure white moonvine in market, very fragrant and as big as a saucer. On this variety we have a world-wide reputation as growers and shippers for the last twenty years. Price, 2 1-2 in. pots, \$5.00 per 100. 10,000 are now ready 4 inch nicely staked up. 12c.

CODFREY ASCHMANN,
1012 W. Ontario St., Philadelphia, Pa.

Myosotis, or Forget-me-not

Good bushy plants, 4 inch pots, \$6.00 per 100. Money with order.

Bedding Plants of all kinds

DENYS ZIRNGIEBEL, Needham, Mass.

JAPANESE

THE YOKOHAMA NURSERY CO. LILIES PLANTS BAMBOO STAKES

31 BARCLAY STR. NEW YORK.

Seed Trade

Counter trade continues active in most of the seed centers north of Mason and Dixon's line, and the weather has generally been wet and cold. It is a good season to test the hardiness and vitality of most seeds, and no doubt there will be many complaints on the latter point.

The season for planting peas for market is practically past and the acreage is much smaller than last year. Should green peas bring good prices, as now seems probable there will be the usual rush to plant peas next year, as always follows a season of high prices on any commodity. Of course this is not good business, but it is the farmer's way, and he never learns though he lives to be a hundred years old. On the contrary, he repeats the mistake with monotonous regularity as long as he lives. Because beans and potatoes brought high prices last year, the soil has been loaded with these two commodities, and if the general crop is good, prices are bound to rule very low.

That the season has been one of the best in the history of the seed trade, is very generally admitted, and excepting on a few varieties reserves are the lowest in many years. If there is any severe shortage on staple varieties this season prices are likely to rule much higher than last year, excepting possibly on yellow varieties of onion seed. Should there be a general failure of these it would prove a blessing.

The usual crop of rumors regarding damage to California seed crops are beginning to float in, but this is such an overworked issue that seedsmen take but a languid interest in it and for this reason are quite liable to be caught napping some time, for short crops are liable to occur in California as elsewhere.

The present cool, wet weather is excellent for grass, and a good hay crop seems to be assured in addition to clover and timothy seed. At any rate, prices on these two items are likely to suffer a severe sinking spell, particularly on clover, which has been selling at abnormally high figures the past winter.

Howard M. Earl of W. Alee Burpee & Co., and W. C. Langbridge of Jerome B. Rice Seed Co., have started for the Pacific coast but expect to get back to Detroit in time for the seedsmen's convention.

Wm. Elliott & Sons are well pleased with their new store at 42 Vesey street New York. They occupy the entire building, which is much more commodious than the one on Fulton which they formerly occupied and in every way better suited to their uses, and as a retail stand it is certainly much more desirable than Fulton street has heretofore been.

The Livingston Seed Co., Columbus, O., has purchased 150 acres of land at Kickerville, which will be devoted to onion raising, seed, sets, etc. A. Wilmer Livingston will be in charge.

PUBLICATIONS RECEIVED.

Some of the Best Hardy Climbing Roses, by Wm. C. Barry. Reprint from the Country Gentleman.

Report of the Park Commissioners of Haverhill, Massachusetts, 1907: Henry Frost is superintendent of this park system.

Bulletin 113, comprising notes on the Habits of Mice, Moles and Shrews, and Bulletin 116 on Starting Young Orchards are received from the West Virginia Agricultural Experiment Station, Morgantown, W. Va.

Bulletin No. 123 of the Massachusetts Agricultural Experiment Station gives formulae for the preparation of fungicides and insecticides with directions for preventing and controlling fungus diseases and insects, both outdoors and in the greenhouse. Dr. George E. Stone and Dr. H. T. Fernald are the authors.

The Care of Trees is the title of a neat little illustrated pocket pamphlet issued by H. L. Frost & Co., of Arlington, Mass., and White Plains, N. Y. The care and preservation of ornamental trees is daily becoming a more and more essential study for the home owner and the horticulturist. Messrs. Frost & Co. employ about 250 men in this work.

Proceedings of the Seventeenth Annual Meeting of the American Carnation Society, Washington, D. C., Jan. 28, 29, 30, 1908. This volume is a worthy addition to the line of interesting annual reports furnished by Secretary Herr. The discussions, reports and papers presented at the convention are given in full. Lists of carnations registered during the year and of members for 1908 are appended. Portraits of President F. H. Lemon and Chas. W. Ward are included, also five pages of illustrations explaining the text of Mr. Ward's paper on Carnation Breeding in America. The book comprises 144 pages.

Two books recently published by the Bobbs-Merrill Company, Indianapolis, Ind., deserve more than a passing notice, representing as they do the best popular literature on outdoor and indoor gardening respectively. This class of literature, while not intended to instruct florists, is, nevertheless, entitled to the respect of the florist trade for the effect of the dissemination of truthful, practical information on garden and floral matters among the people is directly to the interest and benefit of the plant and flower trade. Florists should keep these books on sale so that when customers ask for information on cultural topics their desires may be gratified. *Yard and Garden* is the title of the first book referred to. The author, Tarkington Baker, presents in a masterly manner the possibilities and pleasures in the planting of even the most restricted spaces and well defines the difference between "a house and lot" and "a



AUCTION SALES
TUESDAY & FRIDAYS
AT NOON.

CARPET BEDDING, PLANTS, BAY TREES, PALMS, AND BULBS

W. ELLIOTT & SONS
42 Vesey Near Church
NEW YORK, N. Y.

home." The basic principles of arrangement, the element of garden planning, the selection and planting, together with all the operations connected with successful gardening are presented in a truthful and lucid manner. There are several special chapters on roses, peonies, phloxes, etc. There are 135 illustrations.

The second book we would mention is "Window Gardening", by Herman B. Dorner. Here we have the plain, practical advice of a man brought up in contact with the things of which he writes, and the book should be on the table of every man, woman or child who seeks to brighten the home with growing plants and flowers. It is dedicated to the author's father, Mr. Fred Dorner, of Lafayette, Ind. If the directions given in this useful little book were more widely known and followed many more florists' plants, many more seeds and bulbs would be sold. All the operations of potting and repotting, propagating, watering, fertilizing and ventilation, are described and full information as to soils, light, heat and all diseases and pests that house plants are subject to are fully treated on.

BUSINESS CHANGES.

C. A. Benson has leased the Davis Greenhouses, Denver, Colo.

Joseph Carlton has purchased the greenhouses of A. W. Tweedie at Cadillac, Mich.

Joel Thomas, of Fitzgerald, Ga., reports splendid prospects for fruit of all kinds. The first and second crops of strawberries just gone. The crop of blackberries is large and is now ripe.

VEGETABLE PLANTS

CABBAGE Wakefield, I. I., Second Early, Early Flat Dutch, Early Summer, Wmingsstadt, and other late var. at \$1.00 per 1000, \$8.50 per 10,000.

BEEF Eclipse, Crosby's, Egyptian, at 25c per 100, \$1.25 per 1000.

LETTUCE Boston Market, Tennis Ball, Big Boston Grand Rapids, 20c per 100, \$1 per 1000.

CELERY White Plume, G. S., Blanching at 20c per 100, \$1.00 per 1000.

Cash with Order.

R. Vincent, Jr., & Sons Co., White Marsh, Md.

PLANT IMPORTS.

Entered at New York, May 6th to May 19th, 1908.

From Rotterdam: Maltus & Ware, 8 pgs. plants; J. M. Thorburn & Co., 44 dbl. seed; Forwarders, 3 cases plants.

From Antwerp: H. F. Darrow, 74 es. plants, 90 tubs laurel trees; O. G. Hempstead & Sons, 28 es. plants; McHutchison & Co., 66 es. do., 154 tubs laurel trees; Maltus & Ware, 17 es. plants, 120 pgs. do., 4 tubs laurel trees; Chas. F. Meyer, 12 tubs do., 20 es. plants; W. Mutilod, 5 es. do., 8 tubs laurel trees; T. H. Petry & Co., 66 tubs do., 19 es. plants; Julius Roehrs Co., 8 es. do., 184 tubs laurel trees; Rooney & Spence, 5 tubs do.; John Scheepers & Co., 2 tubs do., 43 es. plants; J. TerKuile, 24 es. do., 28 tubs laurel trees; Vaughan's Seed Store, 2 tubs do., 29 es. plants; Wadley & Smythe, 7 es. do.; Sundry Forwarders, 56 es. do., 278 tubs laurel trees.

Via Southampton: H. F. Darrow, 19 pgs. seed; O. G. Hempstead & Son, 13 es. plants; Maltus & Ware, 3 es. do.; Sundry Forwarders, 7 es. do.

From London: C. A. Haynes & Co., 2 es. orchids.

From Glasgow: J. M. Thorburn & Co., 21 bags grass seed.

From Germany: Julius Roehrs, 18 lbs. plants; Sundry Forwarders, 3 es. do.

INCORPORATED.

Minier Plant Co., Bloomington, Ill. Southern Alabama Plantation Co., Silverhill, Ala.; capital \$50,000.

Palisades Nurseries, Sparkill, N. Y.; A. McGilvray, J. M. Stevens, James Cochran; capital, \$15,000.

The J. S. Wilson Floral Co., Des Moines, Ia.; J. S. Wilson, manager, Robt. Bebb; capital, \$25,000.

Sneed Nursery & Orchard Co., Tyler, Texas; J. F. Sneed, C. W. Wood, F. Brunton; capital, \$45,000.

Orroville Nursery Co., Orroville, Wash.; D. W. F. Reed, J. R. Fraser, J. F. Irving; capital, \$1,500.

Southeast Nursery Co., Beaumont, Texas; E. McMicken, J. W. T. A. and A. Spurlock; capital, \$6,000.

South Jersey Seed Co., Camden, N. J.; J. A. Ballenger, G. H. Horner, Mullica Hill; O. B. Bedrow, Camden; capital, \$10,000.

Winter-flowering SWEET PEA SEED

All Colors

New crop ready in August next. Ask for list.

A. C. ZVOLANEK
ORIGINATOR, BOUND BROOK, N. J.

XXX SEEDS

CHINESE PRIMROSE. Finest grown, varieties mixed; 500 seeds, \$1; half pkt., 50c.

CINERARIA. Finest large-flowering dwarf, mixed; 1000 seeds, 50c.

GIANT PANSY. Best large-flowering, mixed, critically selected; 5000 seeds, \$1; half pkt., 50c. Cash.

JOHN F. RUPP, SHIRE TANTSTOWN, PA.
The Home of Primroses.

BRECK'S SEEDS

For Farmer, Market Gardener and Florist
New Crop High Grade
Catalogues mailed free on application

Joseph Breck & Sons Corp.
47-54 NO. MARKET ST., BOSTON, MASS.

Michell's Clearing Sale of Tuberoses, Lilies, and Cycas.

TUBEROSES

Mammoth Pearl Pure White, First Size
Bulbs, \$8.00 per 1000.

CYCAS REVOLUTA

25 pounds, \$2.25
100 pounds, 8.50

HARDY JAPANESE LILIES

Lil. Album 8-9, per 100 \$6; 1000 \$60 | Lil. Rubrum 8-9, per 100 \$5.00, 1000 \$47.50
" 9-11, " 11; " 100 | " 9-11, " 7.50, " 70.00

Headquarters for LIL. FORMOSUM

Henry F. Michell Co., 1018 MARKET STREET Philadelphia, Pa.

ASTER GROWERS ATTENTION:—

Our Seed is All Sold. If you failed to get some it is your loss. However:— Get a Competition Card Now, Enter your name as an Aster Grower of America and win part of our \$250.00 offered in prizes. Entry free. All information gladly given. No cost to you except to prepay the express charges on flowers sent in competition.

Altimo Culture Co., Canfield, Ohio.



Seeds of ASPARAGUS PLUMOSUS NANUS, \$2.00 per 1000.

Seeds of ASPARAGUS PLUMOSUS ROBUSTUS, \$2.00 per 1000.

COLD STORAGE LILY OF THE VALLEY PIPS

JAPAN LILIES, JAPAN IRIS

For prices, state quantities required.

J. M. THORBURN & CO.
33 Barclay St., through to 38 Park Place
NEW YORK

Best Quality Fall Bulbs

It is to your advantage to place your order early. Send us a list of your wants and we will quote you rock-bottom prices. Copy of our Florists' Bulb Catalogue will be sent upon request. Catalogues now ready.

VICK'S SUPERB PANSY SEED

All the best varieties in separate colors

VICK'S SUPERB MIXTURE

the best strain from all the leading named sorts

1-8 oz. 75c. 1-4 oz. \$1.50 Ounce \$5.00

JAMES VICK'S SONS, Rochester, N. Y.

PRIMULA, FRINGED SINENSIS

This seed has been grown for us by a specialist in the culture of Primula, and he has produced plants of sturdy growth, large, thick flowers beautifully fringed and carried on erect stems well above the foliage; unexcelled in size, substance and beautiful colors.

Giant Perfection Strain, 1 nest Mixed, 1-64 oz., \$1.00
Pure White, Brilliant Pink, Blue, Chiswick Red, and
Crimson, 1-64 oz., \$1.00.

H. E. FISKE SEED CO.
13 Faneuil Hall Sq., BOSTON, MASS.

G. C. MORSE & CO.

Address all communications to our permanent address
48 to 56 Jackson St., San Francisco, Cal.

The Largest Seed Growers
in the United States

RELIABLE SEEDS

SOW NOW

Ageratum Mexicanum Blue Star—
Tr. Pkt. 25c; 6 Tr. Pkt., \$1.25.

Lobelia Erinus Pencilata Hamburgia
Tr. Pkt. 30c; 6 Tr. Pkt., \$1.50.

Primula Obconica Grandiflora—
New Hybrids: Blood-red, Blue, Carmine, Pink, Purple, Violet, Pure-white, Compacta, Gigantea, Fringed Mixed Hybrids, each separate, Tr. Pkt. 50c; 6 Tr. Pkts., \$3.50.

My Catalogue will guide you through Reliable Seeds.
Ask for Same.

O. V. ZANCEN
SEEDSMAN, HOBOKEN, N. J.

JUST ARRIVED

LARGE SHIPMENT OF

High-Grade SCOTCH SOOT.

We have the Stott Double Nozzle
THOMAS J. GREY CO.

32 & 33 So. Market St., BOSTON

BRIDGEMAN'S SEED WAREHOUSE.

RICKARDS BROS

Props.

37 East 19th St., - NEW YORK CITY

BRASLAN SEED GROWERS CO.

GROWERS FOR THE

WHOLESALE TRADE ONLY

SAN JOSE, - - CALIFORNIA

**C A U L I F L O W E R S
C A B B A G E**

HJALMAR HARTMANN & CO.,
12 Stormgade,
COPENHAGEN, DENMARK.

Burpee's Seeds

PHILADELPHIA

Blue List of Wholesale Prices mailed only to those who plant for profit.



My Grandfather used Mr. Hammond's Slug Shot for Potato Bugs. So does my father use it. My Mother puts Slug Shot on roses.



"SLUG SHOT"

Used from Ocean to Ocean

A light, composite, fine powder, easily distributed either by duster, bellows, or in water by spraying. Thoroughly reliable in killing Currant Worms, Potato Bugs, Cabbage Worms, Lice, Slugs, Sow Bugs, etc., and it is also strongly impregnated with fungicides. Put up in Popular Packages at Popular Prices. Sold by Seed Dealers and Merchants.

HAMMOND'S SLUG SHOT WORKS, FISHKILL-ON-HUDSON, N. Y.

For BUGS and BLIGHTS

HAMMOND'S

"SOLUTION OF COPPER"

"FRENCH BORDEAUX MIXTURE"

"GRAPE DUST FOR MILDEW"

"CATTLE COMFORT" FOR MILK COWS

Send for Pamphlets worth having.

Sold by Seed Dealers.

Tobacco Paper

IS THE

STRONGEST,

BEST PACKED,

EASIEST APPLIED.

24 sheets.....	\$ 0.75
144 sheets.....	3.50
288 sheets.....	6.50
1728 sheets.....	35.10

"NICO-FUME"

LIQUID

OVER 40% NICOTINE

By far the

CHEAPEST.

Furnishes the

Most Nicotine for the Money!

JUST NOTE PRICES!

Pint.....	\$ 1.50
½ Gallon.....	5.50
Gallon.....	10.50
5 Gallons.....	47.25

... Manufactured by ...

THE KENTUCKY TOBACCO PRODUCT CO.,

Louisville, Ky.

A METHOD OF PROPAGATION OF SCIADOPITYS VERTICILLATA.

By A. Kelech, Russia. Trans. from Moller's Deutsche Gartner Zeitung by G. Blecken.

Usually Sciadopitys verticillata is propagated by seeds; also in fact this is the only method mentioned in horticultural literature; but seeds are com-

paratively high priced and as they germinate much harder than seeds of other conifers, and require considerable time and attention, propagation by grafting is much more advantageous.

Grafted plants grow very easily and will in four months be much stronger than three-year old seedlings. Beginning the middle of March the tips of the branches are taken and simply grafted on the roots of the parent plant. These grafts are bound up with oiled woolen thread, and planted immediately in small pots, and placed in a house that is tightly closed up, in about 50 or 60 degrees heat. There they soon will unite and break into growth, when we can begin with the hardening off of the plants, and by the first of July the majority will be so far advanced that they can be planted in a nursery.

The closing up of the grafts with bees-wax, as is necessary with other conifers, is not essential at all, but Sciadopitys must be kept in a much warmer temperature. Plants grafted in this manner will yield ninety per cent., in results.

GREENHOUSES BUILDING OR CONTEMPLATED.

Fairmount, Ind.—Miss A. Dare, rose house.

Toledo, O. J. L. Schiller, house 25x150

Crown Point, Ind.—Alois Frey, range of houses.

Ashland, Wis.—F. C. Smith, range of houses.

Poughkeepsic, N. Y.—W. Yates, violet house.

Front Royal, Va.—Mary E. Tristoe, one house.

Louisville, Ky.—P. G. Reynolds, range of houses.

Lexington, Ky.—J. A. Kellar, two houses, 33x200 each.

Brainerd, Minn.—J. C. McClellan, one house; P. A. Erickson, one house.



The Best Bug Killer and Bloom Saver

For PROOF Write to

P. R. Palethorpe Co.
OWENSBORO, KY.

JAGER SPRAYERS

are money makers and money savers because they enable you to do the work right, with little labor and without wasting solution. We make an outfit for every need, from large Power Sprayers to small Hand Sprayers—each the best of its kind. **Special Sprayer Book Free**, illustrating and describing our complete line. Investigation pays.

Chas. J. Jager Co., 241-3 Franklin St., Boston, Mass.
Branch: 25 Canal St., Providence, R. I.

DON'T EXPERIMENT

USE

TO-BAK-INE

and your stock will be free from insects, clean, and the blooms will not be discolored.

Send for full information of

W. W. RAWSON & CO.,
5 Union St., Boston.

STUMPP & WALTER CO.,
50 Barclay St., New York.

HENRY F. MICHELL & CO.,
1018 Market St., Philadelphia.

E. H. HUNT, Gen'l Agent,
76-78 Wabash Ave., Chicago.

Orchids Orchids

Our Importations Will Arrive in Two Weeks' Time. Prices on cases from \$45.00 to \$50.00 each of 500 strong bulbs or 45 to 50 plants. In order to help our customers we give Special Sale for Fifteen Days.

Established Plants, *C. Trianae*, from 7 to 10 bulbs with no less than two new growths, \$1.00 each, 10 to 15 at \$1.50 each. *C. Gaskelliana*, 15 to 25 at \$2.00.

ORDONEZ BROS., - Madison, N. J.

COLD STORAGE LILIES

COLD STORAGE LILIES, means that you can have Lilies all the year round. What are more useful, or give more character to the funeral piece than the Lily.

We have, and can deliver at any time cold storage Lilies—and can refer you to hundreds that are growing them, why not you?

LILIUM LONGIFLORUM GIGANTEUM is the only longiflorum that gives satisfaction from cold storage—we offer them as follows:—**LILIUM LONGIFLORUM GIGANTEUM** (repacked 6 to 8 inch bulbs 400 in a case, \$8.50 per 100, \$75.00 per 1000, case of 400 for \$30.00. 7 to 9 inch bulbs, 300 in a case \$9.00 per 100, \$85.00 per 1000, \$25.50 per case of 300. 9 to 10 inch bulbs, 200 in a case, \$14.00 per 100, \$130.00 per 1000, \$26.00 per case of 200.

ARTHUR T. BODDINGTON, Seedsman, 342 WEST 14TH STREET, NEW YORK CITY

Lilium Harrisii

The best grown. Absolutely pure stock.
Free from disease. Apply at once to

GEORGE W. WEST, Shelly Bay, Bermuda

ASPARAGUS PLUMOSUS

2 inch, \$2.00 100; \$18.00 1000 | 3 inch, \$3.00 100; \$25.00 1000

for cash to close out

**HUGH GRAHAM CO., DAVID RUST, Receiver
104 So. 13th Street, Philadelphia, Pa.**

AZALEAS for fall delivery, the best that are grown, also **PALMS** for spring or fall delivery, furnished by Belgium; orders booked now....
AUGUST HAERENS, Somergem,
ADDRESS THE AMERICAN REPRESENTATIVES
AUGUST ROLKER & SONS, 31 Barelay Street, or P. O. Box 752, New York

HYACINTHS, TULIPS, NARCISSI AND OTHER BULBS
ROMAN HYACINTHS and the true **PAPER WHITE GRANDIFLORA**
Ask for our Wholesale Trade List at Hillegom

K. VELTHUYS, Hillegom, Holland
Rep. by **FELIX BOSCH, 260 Clarendon St., Boston.**

HIGH GRADE DUTCH BULBS
W. J. ELDERING & SON
Overveen, Haarlem, Holland
Special Quotations, on large quantities. Wholesale Only.

New York Address **HOTEL SEVILLE**

RUBBERS 4 inch pots. \$20.00 per 100, \$2.50 per dozen.

ARAUCARIAS Nice 4 inch stock, 40c. Larger 50c, 75c, \$1.00

BEDDING PLANTS Geraniums, 4 inch Single and Double Dryden, \$8.00 per 100. Other varieties at \$7.00 per 100. *Salvia Zurich* and *Bonfire*, *Lobelia Kathleen Mallard* and all other new and standard bedding stock in best quality at lowest market rates.

JOHN MCKENZIE

North Cambridge, Mass.

ORCHIDS

Largest Importers, Exporters, Growers and Hybridists in the World

Sander, St. Albans, England
and 235 Broadway, Room 1
NEW YORK CITY

Imported Orchids

JUST TO HAND

Laelia Purpurata, *Cattleya Intermedia*, *Cattleya Mossiae*, *Cattleyas Trianae* and *Mendellii*, *Dendrobium Wardianum*, *Oncidium tigrinum* and *splendidum*.

JULIUS ROEHRS CO.,
The Orchid Nurseries RUTHERFORD, N. J.

ORCHIDS for Spring Delivery

NEW IMPORTATIONS

Cattleyas, *Laelias*, *Oncidium*s, etc.

WRITE FOR PRICES

Now is the time to Pot Orchids. Best Quality of Peat, Moss and Baskets on hand.

JOSEPH A. MANDA, 191 Valley Road, WEST ORANGE, N. J.

ORCHIDS

arrived in superb condition

Cattleya Trianae, *C. labiata*, *C. Mossiae*, *Oncidium Varicosum*, *Vanda Coerulea*, *Dendrobium Formosum* and *D. Dalhousieanum*.

LAGER & HURRELL, Summit, N. J.

ORCHIDS

Arrived in fine condition, *C. Mossiae*, *C. Percivaliana*, *C. Trianae*, *C. labiata*, *C. gigas*, *Sanderiana*, *C. Harrisonia*, *C. Schroderae*, *C. citrina*, *Den. Formosum giganteum*, *D. Wardianum*, *D. Findleyianum*, *Oncidium Varicosum*, *Rogersii*, *O. tigrinum*, *O. Ornithorhynchum*, *Laelia anceps*. To arrive shortly, *Vanda Coerulea*, *Cattleya Gaspelliana*, *C. Meodellii*, *Phalaenopsis Amabilis*, *P. Schulleriana*.

GARRILLO & BALDWIN, Secaucus, N. J.

NEPHROLEPIS SCOTTII

in the following sizes, extra good value

25c., 50c., 75c., and \$1
Grand Specimen Plants at \$3, \$4, \$5, \$6.

JOHN SCOTT
Rutland Road and E. 45th St.
Tel. 280 Bedford **BROOKLYN, N. Y.**

NEP. WHITMANI

2 1/4 in., \$5.00 per 100

NEP. WHITMANI

3 1/2 in., \$25.00 per 100

BOSTON FERNS

2 1/4 in., \$3.00 per 100

H. H. BARROWS & SON Whitman, Mass.

In writing to Advertisers kindly mention Horticulture

JOHN BREITMEYER'S SONS

Cor. Miami and Gratiot Aves.
DETROIT, MICH.

Artistic Designs . . .
High Grade Cut Blooms

We cover all Michigan points and good
sections of Ohio, Indiana and Canada

William J. Smyth FLORIST

Cor. Michigan Ave. and 31st St., CHICAGO

We ship to all points in Illinois and Iowa.

Phones: Douglas 744, Douglas 523, Douglas 740

M. C. and J. E. HAUSWIRTH

232 Michigan Ave.
CHICAGO

AUDITORIUM ANNEX Tel. Harrison 585

SAMUEL MURRAY Florist

Coates House Conservatory
1017 BROADWAY, KANSAS CITY, MO
Both 'Phones 2670 Main

FRED C. WEBER FLORIST

4326-28 ST. LOUIS, MO.
OLIVE STREET Established 1873
Long Distance Phone Bell Lindell 676



WASHINGTON,
D. C.

GUDE'S

Geo. H. Cooke FLORIST

Connecticut Avenue and L Street
WASHINGTON, D. C.

The Park Floral Co.

J. A. VALENTINE
Pres.

DENVER, COLORADO

WILLIAM L. ROCK FLOWER CO.

KANSAS CITY, - MO.

will carefully execute orders for Kansas City
and any town in Missouri or Kansas.

PERSONAL.

Visitor in Boston: T. Melstrom, representing Sander & Sons, St. Albans, Eng.

Thomas F. Galvin, of Boston, returned from his trip to Europe May 15 on the Ivernia.

Jackson Dawson, of the Arnold Arboretum, has been ill with bronchitis for the past week and pneumonia was feared but he is now happily recovering and will soon be all right once more.

Dr. W. M. Wheeler has been appointed for five years as instructor in economic entomology with the idea that he will build up that department in the Bussey Institution, Boston. Plans have been formed for the reorganization of the Bussey Institution, but nothing has yet been decided on.

NEWS NOTES.

Fred C. Smith is starting in the nursery business at Ashland, Wis.

Frank Fallon is to start in the nursery business at Winston-Salem, N. C.

W. J. & M. S. Vesey, Fort Wayne, Ind., will open a downtown store on July 1.

C. R. Shake and A. R. Troxell are to start in the florist business at Greencastle, Ind.

The barn and a portion of a greenhouse belonging to Grant Newport of Cedar Rapids, Iowa, were recently struck by lightning and destroyed. The loss is estimated at \$1500, partly covered by insurance.

Commodore Lutgen, partner in the banking house of Belmont & Co., New York, has purchased a plot of nine acres of land in Redding, Conn., in the Sunset Hill district and started to erect a summer home on it. According to the plans provided by Mr. D. Vaux, landscape engineer, almost all of the grounds will be converted into flower gardens, lawns and shrubberies and a range of greenhouses will be erected.

The A. E. Kunderd Gladiolus Gardens is the title of a new firm which has been organized in Kendallville, Ind. The members are M. E. Rice, proprietor of the Majestic Theatre, of Fort Wayne, and A. E. Kunderd, the introducer of the special strain of ruffled gladioli described in our issue of February 8, 1908. Besides the ruffled gladioli of which one or more varieties are to be sent out next fall, phloxes, irises, peonies and other hardy plants will be grown. The farm, which is located two and one-half miles from the city limits, consists of 91 1-2 acres, with excellent transportation facilities for visitors and shipments.

NEW RETAIL FLOWER STORES.

E. H. Lucking, Bradford, Pa.
Griffith, the North Avenue Florist,
160 E. North avenue, Chicago.

You will find something worth reading on every page of HORTICULTURE.

Florists Out of Town

Taking orders for delivery in
New York or Vicinity
can have them filled in best
manner and specially delivered by

Thomas Young, Jr.

500 Fifth Ave., New York City
Telephone 847 Bryant.

ALEX. MCGONNELL

571 FIFTH AVENUE
NEW YORK CITY

Telegraphic orders forwarded to any part of the United States, Canada, and all principal cities of Europe. Orders transferred or intrusted by the trade to our selection for delivery on steamships or elsewhere receive special attention.

Telephone Calls, 487 and 488 38th St.
Cable Address, ALEXCONNELL

WILLIAM H. DONOHUE

FLORAL DECORATOR

17 East 28th St., New York

Special Attention to Theatre
and Steamer Orders, and reliable
deliveries guaranteed.

DAVID CLARKE'S SONS

Deliver orders from any part of the country to
New York City

Or OUT-GOING STEAMERS

Write or telegraph

2139-2141 Broadway, New York
Telephone 1552-1553 Columbus

M. A. BOWE

In the Heart of New York City

1294 Broadway

Tel. 2270, 38th St.

NEW YORK

Our Motto -- The Golden Rule.

YOUNG & NUGENT

42 West 28 St., NEW YORK

"FLOWERS BY TELEGRAPH"

Flower Deliveries

In Brooklyn and other Long Island Points
New York City, New Jersey, etc. At Theatres,
Hotels, Steamers or Residences.

WILSON

Fulton St. and Greene Ave., Brooklyn, N.Y.

ALBANY, N. Y.

EYRES

Flowers or Design Work

DELIVERED IN ALBANY AND VICINITY
ON TELEGRAPHIC ORDER.

11 NORTH PEARL ST., ALBANY, N. Y.

JACOB SCHULZ, 644 Fourth Ave.,
LOUISVILLE, KY.
Cut Flowers of BEST QUALITY in season
delivered promptly to any address.
Write, Telegraph or Telephone.
Cumberland and Home Phones 223 and 984

Chicago.

Established in 1857



1657-1659 Buckingham Place

L. D. Phone 558 Lake View. Send us your retail orders.

We have the best facilities in the city.

PROMPT DELIVERY IN BOSTON

AND ALL NEW ENGLAND POINTS
HOUGHTON & CLARK
396 Boylston St., Boston, Mass.



BOSTON'S BEST
In Quality and Design

Can be relied upon when you transfer your retail orders to

EDWARD MACMULKIN
194 Boylston Street, Boston

Send flower orders for delivery in
BOSTON

and all
NEW ENGLAND POINTS
THOS. F. GALVIN
124 Tremont St., Boston

TRANSFER

Your orders for flower or plant delivery in Eastern New England to

JULIUS A. ZINN,
2 Beacon St., Boston.

Fine Design Work a Specialty

YALE Orders for flower deliveries to Yale College and all other Connecticut points carefully filled and delivered by

J. N. CHAMPION & COMPANY
1026 CHAPEL STREET NEW HAVEN, CONN.

The Far-Famed Flowers of
TORONTO

Delivered on mail or telegraph order for any occasion, in any part of the Dominion.

JOHN H. DUNLOP,
96 Yonge St., Toronto. Ont.

ATLANTA FLORAL CO.
41 Peachtree Street, ATLANTA, GEORGIA.

We manufacture
Self Watering Flower Boxes
for
Windows, Porches and Cemeteries
splendid for placing on
GRAVES



Water reservoir needs refilling but once in two weeks. Made of galvanized iron. Rust proof, leak proof, beautifully finished, and will last for many years. Made in all sizes.

Send \$2.00 for Sample Box
37 in. long and see how quickly you can double your money and also increase the sale of your plants. Illustrated booklet sent free on request

Illinois Heater & Manufacturing Co.
3946 Wentworth Ave., Chicago, Ill.

WHITE OR GREEN ENAMELED
CEMETERY or LAWN CUT FLOWER VASES
These will give perfect satisfaction to your customers.



Made in 2 sizes at the following prices:
No. 1. \$15.00 per 100; \$2.00 per dozen
No. 2. 12.00 " 1.60 "

Let us send you a trial order and convince you of their superiority. Less 10 per ct. for cash with order.

WM. F. KASTING CO., - Wholesale Florists
Sole Owners of Patent
383-387 Ellicott Street, BUFFALO, N. Y.
Carried by all the leading Florist Supply Houses in the country.

PETERSON PATENT

HART'S HANDY HANDLE

"At Easter-time, with a little chiffon decoration, and the Handle, we were able to increase the value of plants from 50% to 100%."— H. E. WILSON.

Write for descriptive circular and prices

GEO. B. HART, 24 Stone St., Rochester, N. Y.

LA CHRYSANTHEME.
This periodical publication, the official organ of the French National Chrysanthemum Society, has just reached its one hundred and first number. The society was founded at Lyons thirteen years ago and has made extraordinary progress, due perhaps in a great measure to its policy of holding its annual convention and show in a different town every year. It now numbers 774 members, inclusive of 58 affiliated societies. Unfortunately its English prototype after 60 years existence in the capital of the British Empire, is a long way from such a numerical result. The issues of Le Chrysantheme are usually filled with readable matter to those interested in the golden flower and members living at a distance have thus an opportunity of knowing what the society is doing and get something for their money besides a ticket for a show which they cannot attend.

USEFUL BOOKS.
We can supply the following books, postpaid, at the prices listed:—
The Chrysanthemum. Herrington Price, 50 cts.
How to Make Money Growing Violets. Saltford. Price, 25 cts.
Daffodils-Narcissus and How to Grow Them. A. M. Kirby. Price, \$1.10.
Commercial Violet Culture. Dr. B. T. Galloway. Price, \$1.50.

Water Gardening. Peter Bisset. Price, \$2.50.
Lawns and How to Make Them. Leonard Barron. Price, \$1.10.
Roses and How to Grow Them. By Many Experts. Price, \$1.10.
The New Cyclopedia of American Horticulture. L. H. Bailey. Four volumes; \$20.00.
How to Make School Gardens. H. D. Hemenway. Price, \$1.10.
How to Make A Fruit Garden. S. W. Fletcher. Price, \$2.20.
How to Plan the Home Grounds. S. Parsons, Jr. Price, \$1.10.
How to Make a Vegetable Garden. Edith L. Fullerton. Price, \$2.20.
The Art of Landscape Gardening. By Humphrey Repton. Price, \$3.22.
All prices are postpaid.
The First County Park System. F. W. Kelsey. Price, \$1.25.
50 cts.
Manual of the Trees of North America. C. S. Sargent. Price, \$6.00.
HORTICULTURE PUB. CO.,
11 Hamilton Place, BOSTON

ROBERT J. DYSART,
Public Accountant and Auditor
Simple methods of correct accounting especially adapted for florists' use.
Books Balanced and Adjusted
Merchants Bank Building
28 STATE ST., BOSTON
Telephone, Main 38.

GREENS for DECORATION DAY

New Crop Dagger Ferns, \$2.00 per 1000.
Bronze and Green Galax, \$1.00 per 1000,
\$7.50 per case.
Leucothoe Sprays, bronze or green, 75c per
100, \$6.50 per 1000.

The Leo Niessen Company
1209 Arch St., Philadelphia, Pa.
Open from 7 a. m. to 8 p. m.

Peonies for Memorial Day

We will have at our command an unlimited supply
of the choicest varieties — all colors.

NAMED CHOICE VARIETIES,
\$6.00 to \$8 00 per 100
FESTIVA MAXIMA, and Other Fancies,
\$15.00 per 100

S. S. PENNOCK - MEEHAN CO.
1608-1620 Ludlow St. PHILADELPHIA
"The" Wholesale Florists of Philadelphia

EVERYTHING SEASONABLE IN

CUT FLOWERS

EDWARD REID, Wholesale Florist
1526 Ranstead St., PHILADELPHIA
STORE CLOSES 8 P. M.

CHAS. W. McKELLAR

51 WABASH AVE., CHICAGO

Western Headquarters for Choice Orchids
Valley, Roses and all Cut Flowers

PETER REINBERG WHOLESALE

CUT FLOWERS

51 Wabash Av., Chicago, Ill.

CUT FLOWER BOXES

EDWARDS FOLDING BOX CO
MANUFACTURERS
PHILADELPHIA, PA.

AMERICAN BEAUTY and all other ROSES

LILY OF THE VALLEY, CARNATIONS
WELCH BROS., 226 Devonshire St., Boston, Mass.

PEONIES FOR DECORATION DAY

All the best varieties assorted colors

W. E. McKISSICK WHOLESALE FLORIST
PHILADELPHIA
1619-1621 RANSTEAD ST.

DAILY CONSIGNMENTS

From 40 to 60 Growers

We can care for your cutflower wants to
advantage.

E. F. WINTERSON CO.
46-47-49 WABASH AVE., CHICAGO

Rice Brothers

115 N. 6th Street, MINNEAPOLIS, MINN.
WHOLESALE FLORISTS and SUPPLIES
CUT FLOWERS received twice daily, and can fill
your orders to your satisfaction. A complete line of
Hardy Greens — WILD SMILAX, BOXWOOD,
HARDY FANCY FERNS, GALAX LEAVES.
Write for quotations on large quantities.

H. BAYERSDORFER & CO.

The Florists' Supply House
of America

Send for Illustrated Catalogue
1129 ARCH ST., PHILA., PA.

TOWER HOTEL

Niagara Falls, N. Y.
is soliciting your patronage during the
S. A. F. Convention.

Very truly yours,
M. J. HOENIG, Prop.

WHOLESALE FLOWER MARKETS—TRADE PRICES—Per 100 TO DEALERS ONLY

	CHICAGO May 18	TWIN CITIES May 18	PHILA. May 19	BOSTON May 20
ROSES				
Am. Beauty, Fancy and Special...	25.00 to 30.00	25.00 to 30.00	12.50 to 20.00	15.00 to 20.00
" Extra.....	15.00 to 20.00	15.00 to 22.00	10.00 to 12.00	12.00 to 15.00
" No. 1.....	10.00 to 15.00	10.00 to 12.00	6.00 to 8.00	6.00 to 10.00
" Lower grades.....	4.00 to 6.00	6.00 to 8.00	3.00 to 5.00	4.00 to 6.00
Bride, 'Maid, Fancy & Special....	6.00 to 8.00	6.00 to 8.00	5.00 to 8.00	5.00 to 6.00
" Lower grades.....	4.00 to 6.00	2.00 to 5.00	2.00 to 4.00	1.00 to 2.00
Killaroe, Richmond, Fan, & Sp....	8.00 to 10.00	8.00 to 10.00	8.00 to 10.00	5.00 to 6.00
" Lower grades.....	4.00 to 6.00	5.00 to 7.00	2.00 to 5.00	1.00 to 4.00
Chatenay, Fancy and Special.....	6.00 to 8.00	5.00 to 8.00	5.00 to 8.00	4.00 to 6.00
" Lower grades.....	4.00 to 6.00	3.00 to 5.00	2.00 to 4.00	1.00 to 3.00
Kaiserin, Carnot.....	6.00 to 8.00 to	3.00 to 8.00	1.00 to 6.00
Golden Gate, Ivory.....	6.00 to 8.00	3.00 to 8.00	3.00 to 8.00	1.00 to 6.00
CARNATIONS				
Fancy and Novelties.....	4.00 to 5.00	2.50 to 3.50	2.00 to 3.00	1.50 to 2.00
Ordinary.....	2.00 to 3.00 to	1.00 to 1.50	.50 to 1.00
MISCELLANEOUS				
Cattleyas.....	40.00 to 50.00 to 50.00	50.00 to 60.00	40.00 to 50.00
Lilies.....	10.00 to 12.00	6.00 to 8.00	8.00 to 10.00	6.00 to 8.00
Lily of the Valley.....	3.00 to 4.00	2.00 to 3.00	2.00 to 3.00	1.00 to 3.00
Daisies.....	.50 to 1.50	.75 to 1.25	.50 to .75	.50 to 1.00
Pansies.....	3.00 to 4.00	3.00 to 4.00	50 to 1.00	.25 to .50
Peonies.....	6.00 to 8.00	6.00 to 10.00	5.00 to 8.00	6.00 to 8.00
Gladioli.....	4.00 to 6.00	5.00 to 15.00	3.00 to 4.00	2.00 to 3.00
Mignonette.....	1.00 to 2.00	2.00 to 3.00	2.00 to 3.00	1.00 to 2.00
Gardenias.....	1.00 to 2.00	5.00 to 50.00	10.00 to 15.00	12.00 to 25.00
Lilac per bunch.....	.15 to .20 to 10.00 to50 to .70
Sweet Peas.....	.50 to 1.00	.60 to .75	.50 to .75	.25 to .50
Adiantum.....	.75 to 1.00	.75 to 1.00	1.00 to 1.50	1.00 to 1.55
Smilax.....	10.00 to 15.00	12.00 to 15.00	15.00 to 20.00	10.00 to 12.00
Asparagus Plumosus, strings.....	25.00 to 40.00	35.00 to 50.00	35.00 to 50.00	25.00 to 50.00
" " & Sprea. (roo bchs.)	15.00 to 20.00	35.00 to 50.00	35.00 to 50.00	15.00 to 50.00

FLOWERS FOR DECORATION DAY Roses, Carnations, Etc.

ORDER NOW FROM

J. A. BUDLONG WHOLESALE CUT FLOWERS
37-39 RANDOLPH STREET, CHICAGO CROWER OF

REED & KELLER
122 West 25th St., New York
Florists' Supplies

We manufacture all our
Metal Designs, Baskets, Wire Work & Novelties
and are dealers in
Glassware Decorative Greens and Florists' Requisites.

J. B. Murdoch & Co.

Wholesale Florists
FLORISTS' SUPPLIES
714 Penn Ave., PITTSBURG, PA.
Long Distance Phone 1435 Court.

New Crop of Ferns — Decoration Day Stock

FANCY FERNS, \$1.25 PER 1000.

DAGGER FERNS, \$1.00 PER 1000.

Edward A. Beaven

Evergreen, Ala.

FLOWER MARKET REPORTS

BOSTON Business stiffened up in the first part of last week and gave some hope of better conditions for the balance of the season, but it proved unstable and activity sagged off again and the street fakir again resumed his throne and his discards again took up their movement direct to the dump. Roses are abundant and there is an awkward congestion on the better grades. Carnations are also plentiful and are selling under stress at figures entirely inadequate and no good purpose is served thereby. Daffodils are about finished but there are some excellent late tulips in market. Sweet peas are very fine. Pond lilies are showing up well but the price is out of all proportion, \$4.00 per hundred being about the high limit. Decoration Day prices will be lower than heretofore but the aggregate sales will probably exceed the record.

BUFFALO Trade was still on the quiet side up to last Saturday, with stock plentiful on all lines, especially on roses of poor quality. Selected quality roses sold well; lily of the valley and sweet peas moved more freely. Outdoor lilacs are in, also jonquils and poeticus narcissus but not in quantity. This week the market opened with a rush and stock moved at a clip reminiscent of the olden days. Shipping trade was lively and the market was once more relieved of its congestion. The outlook for Memorial Day is bright except as to carnations. Bride and Kaiserin roses are in better demand than of late.

CHICAGO Retail trade is rather quiet. Almost continual rain has reduced the number of buyers. Outdoor flowers are selling more readily than any others though roses are moving fairly well. Carnations are not bringing so good a price as a week ago and white ones are especially moving slowly. Red peonies are gone but good pink and white are seen in abundance. Jasmynes are not arriving from the South in very good condition, consequently sales are dropping off and the season which in Chicago lasts only two or three weeks is practically over. Sweet peas are good and ordinary varieties are selling readily at normal wholesale rates, while Butterfly is very fine and brings three dollars per hundred. Beauties are unusually good, and so are Brides, Bridesmaids and Kaiserin. An extraordinarily fine display of cattleyas are to be seen at McKellar's wholesale and at Mangel's retail store this week.

INDIANAPOLIS The past week has been one of the most satisfactory this season. Stock of all

kinds continues good, especially long-stemmed Beauties, which are in good demand. Lily of the valley is selling better than for a long time. Sweet peas are still in heavy demand. Peonies and iris sell reasonably well. Bedding business is in full sway now. All of the local florists are getting a share. With the advent of warm weather there is a good demand for laurels and box trees. Prospects for a good trade and big supply of stock for Memorial Day are bright. From present indications there will be considerable decorating for June weddings.

NEW YORK Trade is stagnant, and a plentiful supply of everything congests the market on all sides. Lilacs are already giving way to peonies and special outdoor spring stock, such as bulb flowers, gardenias, etc., are about finished. Among the conspicuous things during the past week have been the Spanish irises, which have been coming to this market in heavy shipments from southern sources and have been welcomed by the store trade because of their exquisitely brilliant colors. The price has been about fifty cents a hundred.

PHILADELPHIA For the week ending May 18th prices remained about normal, but most of the large influx of all kinds of stock was pretty well cleaned up. Considering previous conditions this may be put down as better than expected. Beauties are still in heavy supply and of fine quality. Liberty, Bride and Bridesmaid are showing the effects of the weather. Richmond, Kaiserin and Killarney are in fine form. Some varieties of carnations are running down, but many are holding their own splendidly. "School day" on the 18th helped considerably on the whites. Cattleyas are good stock and moving nicely. The improvement in the lily of the valley situation keeps up. Southern gardenias have commenced. The warm weather hurts the sweet pea crop a little but the demand keeps up surprisingly well. Lilies are not so plentiful—demand fair. The peony crop commenced arriving on the 15th. Officindis is now plentiful and goes well. By the 25th Festiva Maxima and other chinensis will be in, and promise to be unusually choice. The southern cut is already coming in sparingly.

PHILADELPHIA NOTES.

Visitors this week: James T. Gorman, of the Lord & Burnham Co.; Edwin A. Seidewitz, Baltimore.

Fred Rohlan, of Dreer's, has been laid up with a severe attack of muscular rheumatism for several weeks.

Burnet Landreth and F. W. Brugerhof have started on a trip to California, to occupy about seven weeks.

May 20th was "band day" for the return from a southern business trip of Tausendschon—known to fame also under his proper title of "Captain" Lynch of the Dingee & Conard Co.

"Gardenia Daffodils" are a novelty at Niessen's. This is the old-fashioned double white narcissus, but as we have not seen it in a flower store for ten years or more "old-fashioned" novelty may be a permissible phrase.

An interesting group of wild flowers is a feature of the Battles' display this week. Among those noted were Cynthia, Viola pedata, Viola blanda, Houstonia coerulea. This may not be business but it informs and pleases the passing crowd.

It was rumored that the H. F. Michell Co. intended to move to 5th and Market streets this season, but in a talk with H. F. Michell he informs us that the present intention is to remain at the old stand for two years and rent the new location in the meantime to other tenants.

Watch These Columns

for News of the

CUT FLOWER TRADE

If You Want
Flowers for

MEMORIAL DAY

You will find the most Reliable
Dealers always advertising in

HORTICULTURE

Write to Them.



Bostrom Improved Builders' Levels and Farm Levels

For Park, Cemetery and Landscape Gardening use, take the place of expensive Engineering Instruments. Simple in construction, easily adjusted, more substantial and less cumbersome than the more elaborate and complicated instruments. Practical, up-to-date instrument that any one can use. Write for descriptive circulars and be convinced that this Level is necessary to complete your outfit. Builders' Level \$25.00. Farm Level \$12.50.

BOSTROM-BRADY MFG. CO., 139 Madison Avenue., ATLANTA, GA.

JOHN YOUNG
WHOLESALE FLORIST
 Finest American Beauties and Carnations
 51½ West 28 St. - NEW YORK

FORD BROTHERS
 48 West 28th Street, NEW YORK
FINE ROSES FANCY CARNATIONS
 A Full Line of All CUT FLOWERS
 Telephone, 3870 or 3871 Madison Square

H. E. FROMENT,
 Wholesale Commission Florist,
 Choice Cut Flowers,
 57 West 28th St., :: NEW YORK.
 Telephones: 2200, 2201, Madison Square.

The Reliable Commission House
 Richmond Roses and Rich Flowers
 of all varieties
JOS. S. FENRICH
 110 W. 28th Street, New York
 Tel. 324-325 Madison Square

Alfred H. Langjahr
 All choice cut-flowers in season. Send
 for quotations. Correspondence with
 shippers of first-class stock invited.
55 West 28th Street, New York.
 Telephones 4626-4627 Madison Square

JOHN I. RAYNOR
Wholesale Commission Florist SELLING AGENT FOR
 LARGEST GROWERS
 A full line of Choice Cut Flower stock for all purposes. Comprises every variety
 grown for New York market, at current prices
 TEL. 1998 MADISON SQUARE 49 W. 28 St., New York City

Walter F. Sheridan
 Wholesale Commission Dealer in
CHOICE CUT FLOWERS
 39 West 28th Street, New York
 Telephone: 3532-3533 Madison Square

HEADQUARTERS FOR NOVELTIES
ORCHIDS A SPECIALTY
 THE HIGHEST GRADE OF **VALLEY** ALWAYS ON HAND
 CARNEDIAS, DAISIES, ROSES AND CARNATIONS
 Telephone
JAMES McMANUS, 769 Mad. Sq. 42 W. 28th St., New York

PHILIP F. KESSLER 55 & 57 W. 26th St., New York City
 Commission Dealer, Wholesale Buyer
 and Seller of
CUT FLOWERS
 Open from 5 a. m. to 6 p. m. Sunday
 till 10 a. m.
 Tel., 5243 and 2921 Madison Sq. Res., 345 J., Newtown
Finest Lilies in the Market Every Day in the Year.

WHOLESALE COMMISSION FLORIST **J. K. ALLEN** 106 W. 28 ST. NEW YORK
 Telephone 107 Madison Sq.
 OPEN 6 A.M. DAILY
 We have a good regular outlet for seasonable flowers

NEW YORK QUOTATIONS PER 100—TO DEALERS ONLY

	Last Half of Week ending May 16 1908	First Half of Week beginning May 18 1908	Last Half of Week ending May 16 1908	First Half of Week beginning May 18 1908
Roses				
Am. Beauty, lae and sp.	10.00 to 15.00	8.00 to 15.00		
" extra	6.00 to 8.00	5.00 to 8.00		
" No. 1	4.00 to 6.00	3.00 to 5.00		
" Lower grades50 to 1.00	.50 to 2.00		
Bride, 'Maid, lae and sp	3.00 to 5.00	3.00 to 5.00		
" lwr. grds.50 to 1.00	.50 to 1.00		
Killarney, Richmond, fancy & spec lower grades	3.00 to 8.00	4.00 to 8.00		
Chateau, Fancy and Special	3.00 to 5.00	3.00 to 6.00		
" Lower grades50 to 1.00	.50 to 2.00		
Kaiserin, Carnot50 to 5.00	.50 to 5.00		
Golden Gate, Ivory50 to 4.00	.50 to 4.00		
Carnations, Fancy and Novelties.	1.00 to 2.00	1.00 to 2.00		
" Ordinary50 to 1.00	.50 to 1.00		
Cattleyas	20.00 to 40.00	25.00 to 40.00		
Lilies	2.00 to 4.00	3.00 to 5.00		
Lily of the Valley	1.00 to 3.00	1.00 to 2.00		
Daisies25 to .50	.25 to .50		
Pansies	15 to .25	15 to .25		
Peonies	4.00 to 6.00		
Gladioli	4.00 to 8.00		
Nigronette50 to 1.00	.50 to 1.00		
Gardenias	2.00 to 12.00	3.00 to 15.00		
Lilac per bunch15 to .25	.0 to .25		
Sweet Peas per 100 bunches	2.00 to 6.00	2.00 to 6.00		
Adiantum50 to .75 to .50		
Smilax	10.00 to 12.00	8.00 to 12.00		
Asparagus Plumosus, strigs.	15.00 to 25.00	15.00 to 25.00		
" " & Sprea. (too bchs.)	15.00 to 25.00	15.00 to 25.00		

Edward C. Horan
Wholesale Florist
 55 WEST 28th ST.
 Tel. 1462 Madison Square New York
 1463

TRAENDLY & SCHENCK
WHOLESALE FLORISTS
 Furnish best stock at fair prices all the year round Send for quotations on fall orders
 Tel. 798-799 Madison Sq. 44 West 28th Street, New York City

Moore, Hentz & Nash,
 Wholesale Commission Florists,
 55 and 57 West 26th Street,
 Telephone No. 756
 Madison Square. New York.

Alexander J. Guttman
THE WHOLESALE FLORIST OF NEW YORK
34 WEST 28th STREET
 PHONES. 1664--1665 MADISON SQUARE
ENOUGH SAID



HARDY CUT FERNS

Sphagnum Floss, Extra Large Bales, per bale, \$1.25. Fancy and Dagger Ferns our specialty. A trial order will convince you that we ship only first-class stock. Headquarters for Florists' supplies and wire work. All cut flowers in season. **BOXWOOD**, per bunch 35c, 50 lbs. \$7.50.
MICHIGAN CUT FLOWER EXCHANGE, INC., All 'phone connections 38-40 Broadway, Detroit, Mich.

FANCY and DAGGER
 Extra fine, \$1.75 per 1000. Bronze and Green Galax, \$1.25 per 1000. Leucothoe Sprays, \$1.00 per 100, \$7.50 per 1000.

Headquarters in Western New York
 FOR
ROSES, CARNATIONS
 And all kinds of Seasonable Flowers
Wm. F. Kasting Co.
 Wholesale Commission Florist, also Dealer in Florists' Supplies and Wire Dealings.
383-87 ELLICOTT ST. BUFFALO, N. Y.
 Give us a trial. We can please you.

FRANK S. HICKS & CO.
 Wholesale Florists.
 Open Now for Consignments of Cut Flowers.
 39 West 28th Street, - New York City
 Tel. 2920 Mad. Sq.

WILLIAM H. KUEBLER
 Brooklyn's Foremost and Best
WHOLESALE COMMISSION HOUSE
 A First Class Market for all CUT FLOWERS
 28 Willoughby St., Brooklyn, N. Y.
 Tel. 4591 Main

HENRY M. ROBINSON & CO.

Wholesale and Commission
FLORISTS

Hardy Cut Evergreens and Florists' Supplies
 15 Province St. and 9 Chapman Place,
BOSTON, MASS.

Flowers and Florists' Supplies
 The best place in AMERICA to buy
BAY TREES

N. F. McCarthy & Co.
 84 Hawley St., BOSTON, MASS.
 Largest Dealers in Supplies in New England.

SAMUEL A. WOODROW
WHOLESALE PLANTSMAN
 Palms, Large and Small Ferns, etc.
 53 West 30th Street, NEW YORK
 Telephone 2083 Madison

You will find something worth reading on every page of HORTICULTURE.

BOSTON FLORIST LETTER CO.
 Manufacturers of FLORISTS' LETTERS

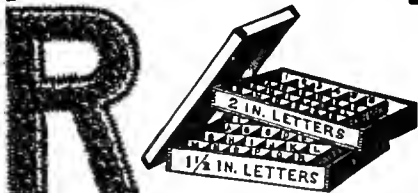

This wooden box nicely stained and varnished, 18x30x12, made in two sections, one for each size letter, given away with first order of 500 letters
 Block Letters, 1 1/2 or 2 inch size per 100, \$2.
 Script Letters, 3. Fastener with each letter or word. Used by leading florists everywhere and for sale by all wholesale florists and supply dealers
N. F. McCARTHY, Manager
 66 Pearl Street, BOSTON, MASS.

WHOLESALE FLOWER MARKETS. — PER 100. TO DEALERS ONLY.

	CINCINNATI May 19	DETROIT May 18	BUFFALO May 19	PITTSBURG May 18
ROSES				
Am. Beauty, Fan, and Sp.....	20.00 to 25.00	20.00 to 25.00	15.00 to 20.00	20.00 to 25.00
" Extra	15.00 to 20.00	12.00 to 15.00	12.00 to 15.00	12.50 to 15.00
" No. 1.....	8.00 to 10.00	6.00 to 10.00	6.00 to 12.00	6.00 to 8.00
" Lower grades.....	4.00 to 6.00	2.00 to 4.00	2.00 to 6.00	2.00 to 4.00
Bride, "Maid, F. & S.....	5.00 to 6.00	6.00 to 8.00	6.00 to 7.00	6.00 to 8.00
" Low. gr.....	2.00 to 4.00	2.00 to 3.00	3.00 to 5.00	3.00 to 4.00
Killarney, Richmond, Fan, & Sp...	6.00 to 8.00	6.00 to 8.00	6.00 to 7.00	6.00 to 8.00
" Lower grades.....	3.00 to 4.00	2.00 to 3.00	3.00 to 5.00	3.00 to 4.00
Cbatenay, Fancy and Special.....	6.00 to 8.00	6.00 to 8.00	6.00 to 7.00	6.00 to 8.00
" Lower grades.....	3.00 to 4.00	2.00 to 3.00	3.00 to 5.00	3.00 to 4.00
Kaiserin, Carnot.....	4.00 to 6.00	5.00 to 6.00	6.00 to 7.00	2.00 to 4.00
Golden Gate, Ivory.....	4.00 to 6.00 to 6.00	5.00 to 6.00	6.00 to 8.00
CARNATIONS				
Fancy and Novelties.....	2.50 to 3.00	2.00 to 3.00	2.00 to 2.50	2.00 to 3.00
Ordinary.....	1.00 to 2.00	1.00 to 2.00	.75 to 1.50	.75 to 1.00
MISCELLANEOUS				
Cattleyas.....	40.00 to 50.00	50.00 to 60.00	60.00 to 75.00 to 75.00
Lilies.....	8.00 to 10.00	6.00 to 8.00	8.00 to 12.00	6.00 to 8.00
Lily of the Valley.....	2.00 to 4.00	2.00 to 3.00	3.00 to 4.00	3.00 to 4.00
Daisies.....	.50 to 1.00	.50 to 1.00	1.00 to 2.00	1.00 to 2.00
Pansies.....	3.00 to 4.00	8.00 to 10.00 to to .50
Peonies.....	6.00 to 8.00 to 3.00 to	6.00 to 8.00
Gladioli.....	4.00 to 6.00 to 2.00 to	4.00 to 6.00
Mignonette.....	1.00 to 2.00	4.00 to 6.00	1.00 to 3.00	2.00 to 4.00
Gardenias..... to 2.00	20.00 to 35.00	2.00 to 3.00 to 2.00
Lilac per bunch.....	.15 to .25	1.00 to 1.50	1.50 to 2.00	.05 to .10
Sweet Peas.....	.50 to .75	2.00 to 3.00	.40 to .75 to .50
Adiantum..... to 1.00 to 1.00	.50 to 1.00 to 1.00
Smilax.....	10.00 to 12.00	12.00 to 15.00	12.00 to 15.00 to 15.00
Asparagus Plumosus, strings.....	40.00 to 50.00	35.00 to 50.00	50.00 to 60.00	40.00 to 50.00
" " & Sprea. (100 bchs.)	25.00 to 35.00	35.00 to 50.00	35.00 to 50.00	30.00 to 50.00

H. C. BERNING
 Wholesale Florist
 1402 Pine Street, ST. LOUIS, MO.

MILLANG BROS.
 WHOLESALE COMMISSION FLORISTS
 41 West 28th Street
 Telephones 3860 Madison 3861 NEW YORK

A. MOLTZ
 Will purchase flowers on order in N. Y. market and ship carefully at prevailing wholesale prices. Address
 155-57 West 26th Street, New York City

CLEARY'S HORTICULTURAL CO.
 Management AMBROSE T. CLEARY
 Wholesale Contracting, Jobbing, Auction
HORTICULTURAL PRODUCTS
 of every description.
 Consignments Received. Surplus Stock Converted.
 62 Vesey St., NEW YORK

In writing to Advertisers kindly mention Horticulture

Buyer's Directory and Ready Reference Guide

Advertisements under this head, one cent a word. Initials count as words.

Regular advertisers in this issue are also listed under this classification without charge. Reference to List of Advertisers will indicate the respective pages.

Buyers failing to find what they want in this list will confer a favor by writing us and we will try to put them in communication with reliable dealers.

ACCOUNTANT

R. J. Dysart, 28 State St., Boston.
For page see List of Advertisers.

ALTERNANTHERAS

Red Alternantheras at 40 cents per 100.
C. W. Moeckel, 17 Summer St., Fitchburg, Mass.

AQUATIC PLANTS

Aquarium plants the year round. Wholesale and retail. Send for price list. Schmid's Emporium of Pets, 712 12th Street, Washington, D. C.

Water Lilies, Nymphaea Odorata Rosea, \$2.00 per doz. W. J. Bodfish, West Barnstable, Mass.

ARAUCARIAS

A. Leuthy & Co., Perkins St. Nurseries, Roslindale, Mass.

For page see List of Advertisers.

John McKenzie, North Cambridge, Mass.
For page see List of Advertisers.

ASPARAGUS

A. N. Pierson, Cromwell, Conn.
Asparagus Plumosus Seedlings.
For page see List of Advertisers.

J. M. Thornburn & Co., 33 Barclay St., New York.

Plumosus Nanus and P. Robustus.
For page see List of Advertisers.

Hugh Graham Co. (David Rust, Receiver), 104 S. 13th St., Philadelphia.

Asparagus Plumosus.

For page see List of Advertisers.

Asparagus plumosus and Sprengerii, 2-lb., strong, \$2.25 per 100. J. H. Dann & Son, Westfield, N. Y.

Asparagus Plumosa, 2 in. pots. Fine plants, \$3.00 per 100; \$25.00 per 1000. Cash with order or good reference. Erie Floral Co., Erie, Pa.; or, Wm. F. Kaating Co., 385 Ellcott St., Buffalo, N. Y.

ASTER SEED

Altimo Culture Co., Canfield, O.
For page see List of Advertisers.

AUCTION SALES

Cleary's Horticultural Co., 62 Vesey St., New York.

For page see List of Advertisers.

Wm. Elliott & Sons, 42 Vesey St., New York.
For page see List of Advertisers.

AZALEAS

A. Leuthy & Co., Perkins St. Nurseries, Roslindale, Mass.

For page see List of Advertisers.

August Rolker & Sons, New York, 31 Barclay St., or P. O. Box 752.

For page see List of Advertisers.

BAMBOO CANES

Yokohama Nursery Co., 31 Barclay Street, New York.

For page see List of Advertisers.

BAY TREES.

N. F. McCarthy & Co., 84 Hawley St., Boston.

For page see List of Advertisers.

Bay Trees and Box Trees, standards and pyramids. All sizes. Price list on application. J. Roehrs Co., Rutherford, N. J.

BEDDING PLANTS

R. Vincent, Jr., & Sons Co., White Marsh, Maryland.

For page see List of Advertisers.

40,000 geraniums, 10 best standard sorts; 5000 Vinca variegata; Salvia; bellotrope, dark; feverfew, double white. Good stock, prices right. E. D. Knudback & Son, Malden, Mass.

BEDDING PLANTS — Continued

A. N. Pierson, Cromwell, Conn.
For page see List of Advertisers.

A. Leuthy & Co., Perkins St. Nurseries, Roslindale, Mass.

For page see List of Advertisers.

F. R. Pierson Co., Tarrytown-on-Hudson, N. Y.

For page see List of Advertisers.

Godfrey Aschmann,

1012 W. Ontario St., Phila., Pa.
For page see List of Advertisers.

Bargains in pot-grown plants, in variety, ready for market at once. Send for prices. It will pay you. Alonzo J. Bryan, Washington, New Jersey.

PLANTS in 2-in. pots, prepaid on Southern Express, for 2c. Alternantheras, red and yellow, Salvia, Ageratum, Double Alyssum; 10 kinds of Colens. Thomas Greenhouses, 602 East Magnolia Street, Fitzgerald, Ga.

Geraniums in 3-1/2 in. pots, S. A. Nutt, Inc. Doyle, Frances Perkins, Bertha de Presilly, Beante Poitevine, Double White, Castellane, \$7 per 100, shipped in paper pots. Mine Sallerol, 2-1/2 in. pots, \$3 per 100. Compacta and Gracilis Lobelia, \$3 per 100. Golden Feather, \$2. Marguerite Carnations, \$3. Centaurea Gymnocarpa, \$3. J. B. Shurtleff & Son, Cushman, Ave., Revere, Mass.

Geraniums—Choice mixed colors, strong plants, 4 in. pots, \$7.00 per 100. Periwinkle, strong plants, 4 in. pots, \$8.00 per 100. Double white fringed Petunias, very strong plants, measure 4 in. across, \$10.00 per 100. Dracaena Indivisa, 4 in. pots, \$2.00 per dozen. Hardy English Ivy, 3 feet long, 4 in. pots, \$1.50 per dozen. Double Petunias 2 in. pots, \$2.00 per 100. Rose Geraniums, 3 in. pots, \$3.00 per 100. Geraniums, mixed, choice colors, 3 in. pots, \$3.00 per 100. Double white Petunias, 3 in. pots, \$1.00 per 100. Cuphea, 3 in., \$2.50 per 100. Thunbergia, Black Eye, buff or white, 3 in. pots, \$2.50 per 100. Scarlet Sage, 3 in. pots, \$2.50 per 100. Single Petunias, dwarf, 3 in., \$2.50 per 100. Dusty Miller, Centaurea gymnocarpa, 3 in. pots, \$2.50 per 100. Moon Vines, strong, 3 in. pots, \$4.00 per 100. Begonia Vernon, large flowering, 3 in., \$3.00 per 100. Kenilworth Ivy, 3 in., \$2.50 per 100. Lobelia, 3 in., \$2.50 per 100. Nasturtiums, 3 in. a pot, dwarf, 3 in. pots, \$2.50 per 100. Parlor Ivy, 3 in. pots, \$2.50 per 100. Phlox, 3 in. pots, \$2.50 per 100. Alyssum, this is extra strong dwarf, 3 in. pots, \$2.50 per 100. All kinds of aquatic plants and fancy gold fish. Cash with orders. Samuel V. Smith, 3223 Goodman Street, near 11th and Ontario, Philadelphia, Pa.

BEGONIAS

Thomas Roland, Nahant, Mass.
Gloire De Lorraine.

For page see List of Advertisers.

S. S. Skidelsky, 1741 N. 15th St., Phila.
Gloire de Lorraine.

For page see List of Advertisers.

Begonia "Agatha" (Veitch) (Improvement on Beg. Gloire de Lorraine) an easier grower, earlier flowering and of a more pleasing shade of soft, satiny pink; strong young plants from leaf cuttings, now ready; \$18.00 per 100.

Begonia "Gloire de Lorraine", strong, young plants from leaf cuttings, ready for delivery early in June; \$15.00 per 100; \$10.00 per 1000.

J. A. Peterson,
McHenry Ave., Westwood, Cincinnati, O.

BERBERIS THUNBERGII

Oak Hill Nurseries, Roslindale, Mass.
For page see List of Advertisers.

BOILERS

BOILERS. "Burnham" Boilers made for greenhouse heating. Lord & Burnham, 1133 Broadway, N. Y.

Kroeschell Bros. Co., 35 Erie St., Chicago.
For page see List of Advertisers.

BOUVARDIA HUMBOLDTII

Anderson & Williams, Waltham, Mass.
For page see List of Advertisers.

BUILDERS' AND FARM LEVELS

Bostron-Brady Mfg. Co., 139 Madison Ave., Atlanta, Ga.

For page see List of Advertisers.

BUILDING MATERIAL

BUILDING MATERIAL of all description for All Cypress, Semi-Iron, Iron Frame or Truss Houses. Hot Bed Sash and Frames. Lord & Burnham Co., 1133 Broadway, N. Y.

BULBS AND TUBERS

Joseph Breck & Sons, 47-54 N. Market St., Boston.

For page see List of Advertisers.

J. M. Thornburn & Co., 33 Barclay St., New York.

For page see List of Advertisers.

A. T. Boddington, 342 W. 14th St., N. Y.
Cold Storage Lilies.

For page see List of Advertisers.

Rickards Bros., 37 East 19th St., New York.
For page see List of Advertisers.

H. F. Mitchell Co., Philadelphia.

For page see List of Advertisers.

H. E. Fiske Seed Co., Fanelli Hall Sq., Boston.

For page see List of Advertisers.

James Vlek's Sons, Rochester, N. Y.

Fall Bulbs.

For page see List of Advertisers.

Aug. Rolker & Sons, 31 Barclay St., New York.

Seasonable Import Plants and Bulbs.

For page see List of Advertisers.

K. Veithuys, Hillegom, Holland,
Represented by Felix Boseb, 260 Clarendon St., Boston.

Bulbs French and Dutch.

For page see List of Advertisers.

W. J. Eldering & Son, Overveco, Haarlem, Holland.

High Grade Dutch Bulbs.

For page see List of Advertisers.

A. Mitting, 17-23 Kenan St., Santa Cruz, California.

Calla Bulbs.

For page see List of Advertisers.

CANNAS

The Conard & Jones Co., West Grove, Pa.
For page see List of Advertisers.

Started Cannas from sand, \$2; from pots, \$5. J. B. Shurtleff & Son, Cushman Ave., Revere, Mass.

Godfrey Aschmann,

1012 W. Ontario St., Phila., Pa.
For page see List of Advertisers.

CAPE JASMINE BUDS

Chas. Ehlers, Houston, Texas.

CARE OF TREES

H. L. Frost & Co., White Plains, N. Y.;
Arlington, Mass.

For page see List of Advertisers.

For List of Advertisers See Page 709

CARNATIONS

F. Dorner & Sons Co., Lafayette, Ind.
For page see List of Advertisers.

Chicago Carnation Co., Joliet, Ill.
For page see List of Advertisers.

John E. Haines, Bethlehem, Pa.
Carnations Imperial and Pink Imperial.
For page see List of Advertisers.

A. N. Pierson, Cromwell, Conn.
For page see List of Advertisers.

H. F. Littlefield, 552 Main St., Worcester, Mass.
For page see List of Advertisers.

Albert Roper, Tewksbury, Mass.
Carnation Bay State.
For page see List of Advertisers.

Cobanzie Carnation Co., New London, Ct.
For page see List of Advertisers.

Carnation cuttings of all the leading varieties at the same price as any reliable firm. Write for prices before you look elsewhere. **Wm. F. Kasting Co., 363 Ellicott St., Buffalo, N. Y.**

CARNATIONS! FIELD GROWN!

15,000 Enchantress and Winsor, ready for delivery July 1st. Orders filled in strict rotation. Order now and be first! Prices on application. We guarantee satisfaction. We lead in superb field grown stock.
WANOKA GREENHOUSES, Barneveld, N. Y.

CAULIFLOWER AND CABBAGE SEED

H. Hartmann & Co., Copenhagen, Denmark.
For page see List of Advertisers.

CEMETERY FLOWER VASES

Wm. F. Kasting Co., 383-87 Ellicott St., Buffalo, N. Y.
For page see List of Advertisers.

CHRYSANTHEMUMS

Chas. H. Totty, Madison, N. J.
Special Offer.
For page see List of Advertisers.

A. N. Pierson, Cromwell, Conn.
For page see List of Advertisers.

Wm. W. Edgar Co., Waverley, Mass.

H. F. Littlefield, 552 Main St., Worcester, Mass.
Rooted Cuttings.
For page see List of Advertisers.

H. L. Cameron, No. Cambridge, Mass.
For page see List of Advertisers.

Chrysanthemums—Christmas, Polly Rose, Pacific, Halliday, Nonin and others, \$1.25 per 100. **F. P. Sawyer, 125 High St., Clinton, Mass.**

Chrysanthemums, strong 2 in. plants of Beatrice May, C. Tousey and Polly Rose, \$2.00 per 100. **Cash, N. E. Beck, Massillon, Ohio.**

Have 100,000 fine young well-rooted 'Mums, cuttings of the best 60 commercial varieties. Send for our new and low price list. Satisfaction guaranteed. **Wm. Ehmann, Jr., Corfu, N. Y.**

Chrysanthemums ready: 2 1/2 inch strong stock of Tousey, Oct. Frost, Polly Rose, Wauamaker, and all standards, \$2 per 100, \$18 per M. New: 2 1/2 inch strong, Alice Roosevelt, Hankey, Clay Erick, Winter Cheer, Rosette, B. May, \$4 per 100, \$30 per M. **Cash. Send for catalog. Harlowarden Greenhouses, Greenport, N. Y.**

COBAEAS

Cobaea scandens from 4 in. pots, \$8.00 per 100. **Wittbold Co., 1657 Buckingham Place, Chicago, Ill.**

COLEUS

A. N. Pierson, Cromwell, Conn.
For page see List of Advertisers.

Coleus, Golden Bedder, Verschaffeltii, and mixed Coleus, rooted cuttings, 60c per 100; \$5.00 per 1000. Cash with order. **J. E. Felthousen, Florist, Schenectady, N. Y.**

CONIFERS

John Waterer & Sons, Ltd., American Nursery, Bagshot, Eng.
For page see List of Advertisers.

CUT FLOWER BOXES.

Edwards Folding Box Co., Philadelphia.
For page see List of Advertisers.

Folding cut flower boxes, the best made. **Write for list. Holton & Hunkel Co., Milwaukee, Wis.**

CYCLAMEN.

Cyclamen, finest Giant strain, separate colors, once transplanted seedlings, 2c.; twice transplanted, 3c.; strong, from 2-in. pots. **For J. L. Schiller, 929 Prouty Ave., Toledo, O.**

DAHLIAS

David Herbert & Son, Atco, N. J.
For page see List of Advertisers.

R. Vincent, Jr. & Sons Co., White Marsh, Maryland.
For page see List of Advertisers.

R. & J. Farquhar & Co., 6 & 7 S. Market St., Boston.
Dahlia Chas. Lanier.

Dahlias, balance of season, 25 named varieties, postpaid, \$1.00. Catalogue free. **J. L. Moore, Northboro, Mass.**

Dahlia roots, named varieties, \$2.00 per 100; mixed, \$1.50 per 100. **Edwin Bishop, Roslyn, Md.**

Dahlias: About 2000 Cath. Dner, Kriemhilde, Brunnhilde, Suoweld, etc., \$3 per 100. **Cash. Harlowarden Greenhouses, Greenport, N. Y.**

Dahlias. Novelties and standard varieties, true to name, a choice list of the best introductions. Send for catalogue of dahlias, hollyhocks, hardy plants, etc. **W. W. Wilmore, Box 382, Denver, Colo.**

DECORATIVE PLANTS

A. Leuthy & Co., Perkins St. Nurseries, Roslindale, Mass.
For page see List of Advertisers.

Godfrey Aschmann, 1012 W. Ontario St., Phila., Pa.
For page see List of Advertisers.

DRACAENAS

Dracaena indivisa, 2 1/2-in., strong seedlings, \$2.00 per 100. Jos. Labe, Joliet, Ill.

Dracaena indivisa: 4 in., \$2.00 per doz., \$12.00 per 100; 5 in., \$3.00 per doz., \$20.00 per 100; 6 in., \$6.00 per doz., \$30.00 per 100. Wittbold Co., 1657 Buckingham Place, Chicago, Ill.

ECHEVERIAS

Echeverias, \$18 per 1000, post paid. McDowell, Mexico City.

ELECTRIC CIRCULATOR

The Castle Co., 170 Summer St., Boston.
For page see List of Advertisers.

FERNS

A. Leuthy & Co., Roslindale, Mass.
For page see List of Advertisers.

H. H. Barrows & Son, Whitman, Mass.
Nephrolepis Whitman.
For page see List of Advertisers.

John Scott, Brooklyn, N. Y.
For page see List of Advertisers.

FERNS FOR DECORATION DAY

E. A. Beaven, Evergreen, Ala.
For page see List of Advertisers.

FERTILIZERS

Pulverized Manure Co., 31 Union Stock Yards, Chicago, Ill.

Wizard Brand Cattle Manure.
For page see List of Advertisers.

Thos. J. Grey & Co., 32 and 33 South Market St., Boston.
High-Grade Scotch Soot.
For page see List of Advertisers.

FLORAL PHOTOGRAPHS

Floral Photographs. Foley's 226-228 1-2 Rowery, New York.

FLORISTS' LETTERS.

Boston Florist Letter Co., 66 Pearl St., Boston, Mass.
For page see List of Advertisers.

FLORISTS SUPPLIES

N. F. McCarthy & Co., 84 Hawley St., Boston.
For page see List of Advertisers.

FLORISTS SUPPLIES — Continued

H. M. Robinson & Co., 15 Province St. and 9 Chapman Pl., Boston, Mass.
For page see List of Advertisers.

Keed & Keller, 122 W. 25th St., New York.
For page see List of Advertisers.

J. B. Murdoch & Co., 714 Penn Ave., Pittsburg, Pa.
For page see List of Advertisers.

H. Bayersdorfer & Co., 1129 Arch St., Philadelphia.
For page see List of Advertisers.

FLOWERS BY TELEGRAPH

Park Floral Co., Denver, Colo.
For page see List of Advertisers.

J. N. Champlin & Co., 1026 Chapel St., New Haven, Conn.
For page see List of Advertisers.

George H. Cooke, Washington, D. C.
For page see List of Advertisers.

Gude Bros. Co., 1214 F St., Washington, D. C.
For page see List of Advertisers.

Atlanta Floral Co., Atlanta, Ga.
For page see List of Advertisers.

M. C. & J. E. Hauswirth, 232 Michigan Ave., Chicago.
For page see List of Advertisers.

William J. Smyth, Michigan Ave. and 31st St., Chicago.
For page see List of Advertisers.

George Wittbold Co., 1657-59 Buckingham Place, Chicago.
For page see List of Advertisers.

Jacob Schulz, 644 4th Ave., Lonlville, Ky.
For page see List of Advertisers.

Thos F. Galvin, 124 Tremont St., Boston.
For page see List of Advertisers.

Jullus A. Zinn, 2 Beacon St., Boston.
For page see List of Advertisers.

Houghton & Clark, 396 Boylston St., Boston.
For page see List of Advertisers.

Sidney Hoffman, 59-61 Massachusetts Ave., Boston.
For page see List of Advertisers.

Edward MacMullin, 194 Boylston St., Boston.
For page see List of Advertisers.

J. Breitmeyer's Sons, Miami and Grandt Aves., Detroit, Mich.
For page see List of Advertisers.

Samuel Murray, 1017 Broadway, Kansas City, Mo.
For page see List of Advertisers.

Wm. L. Rock Flower Co., 1116 Walnut St., Kansas City, Mo.
For page see List of Advertisers.

Fred C. Weber, 4326-28 Olive St., St. Louis, Mo.
For page see List of Advertisers.

H. G. Eyre, 11 N. Pearl St., Albany, N.Y.
For page see List of Advertisers.

David Clarke's Sons, 2139-2141 Broadway, New York.
For page see List of Advertisers.

W. H. Donohoe, 17 E. 28th St., New York.
For page see List of Advertisers.

Alex. McConnell, New York.
For page see List of Advertisers.

M. A. Bowe, 1294 Broadway, New York.
For page see List of Advertisers.

Robert G. Wilson, Fulton St. & Greene Av., Brooklyn, N. Y.
For page see List of Advertisers.

Thomas Young, Jr., 500 Fifth Ave., N. Y.
For page see List of Advertisers.

Young & Nugent, 42 W. 28th St., N. Y.
For page see List of Advertisers.

J. H. Dunlop, 96 Yonge St., Toronto, Can.
For page see List of Advertisers.

FLOWER POTS

W. H. Ernest, 28th and M Sta., Washington, D. C.
For page see List of Advertisers.

A. H. Hews & Co., Cambridge, Mass.
For page see List of Advertisers.

Hilfinger Bros., Ft. Edward, N. Y.
For page see List of Advertisers.

Red pots, seed pans, etc.
The Peters & Reed Pottery Co., Zanesville, O.

In writing to Advertisers kindly mention Horticulture

FOXGLOVES

Foxglove in 3 colors, \$5.00 per 100. J. B. Shurtleff & Son, Cushman Ave., Revere, Mass.

GALAX

Michigan Cut Flower Co., 38 and 40 Broadway, Detroit, Mich.
For page see List of Advertisers.

GERANIUMS

R. Vincent Jr. & Sons Co., White Marsh, Md.

New and Standard Varieties.
For page see List of Advertisers.

Godfrey Aschmann,

1012 W. Ontario St., Phila., Pa.
For page see List of Advertisers.

Wm. W. Edgar Co., Waverley, Mass.
For page see List of Advertisers.

H. L. Cameron, No. Cambridge, Mass.
For page see List of Advertisers.

I have a lot of good 4-in. Geraniums in the following varieties about 20,000 in all: Nutt, La Pilot, Flora Hill, Buchner, Mue. Salleri and a few others at from \$7.00 to \$10.00 per 100. Also Alternantheras, mostly red, at \$2.00 per 100; Coleus at \$2.50 per 100; and a few other varieties in plants. Hermann Schoenfeld, 86th and Crothers Ave., Elmhurst, Philadelphia, Pa.

30,000 geraniums, 15 varieties. Fine stock, very branched, full of bud and bloom. Any variety or mixed colors, double or single, \$7.00 per 100. Alonzo J. Bryan, Washington, New Jersey.

8,000 Geraniums in bud and bloom, out of 3 1/2 in. pots. Fine stock, S. A. Nutt, double white and mixed. Salvia, out of 3 1/2 in. pots, \$5.00 per 100. Cash with order. L. Cousins, Jr., Concord Junction, Mass.

Geraniums, 2 in., double red, \$1.50 per 100. J. H. Dann & Son, Westfield, N. Y.

GLADIOLI

Gladiolus, large flowering mixed, balance of season, \$1.00 per 100; postpaid. J. L. Moore, Northboro, Mass.

Gladioli, choice mixed, 65c. per 100. W. I. Bodfish, West Barnstable, Mass.

GLASS

Boston Plate & Window Glass Co., Boston.
For page see List of Advertisers.

Standard Plate Glass Co., 26-30 Southbury St., Boston.
For page see List of Advertisers.

S. Jacobs & Sons, 1365-79 Flushing Ave., Brooklyn, N. Y.

Metropolitan Material Co., 1398-1408 Metropolitan Ave., Brooklyn, N. Y.
For page see List of Advertisers.

Foley Mfg. Co., Western Ave., between 25th & 26th Sts., Chicago.

Greenhouse glass, lowest prices. Johnston Glass Co., Hartford City, Ind.

GLASS, High Grade, Double Thick Greenhouse Glass. Lord & Burnham, 1133 Broadway, N. Y.

GLAZING POINT

H. A. Dreer, Philadelphia, Pa.
For page see List of Advertisers.

GLAZING POINTS, Lord & Burnham Special Glazing Nails (Points). Lord & Burnham, 1133 Broadway, N. Y.

GREENHOUSE BUILDING MATERIAL

Lord & Burnham Co.,
1133 Broadway, New York.

For page see List of Advertisers.

Pierson U-Bar Co., 1 Madison Sq., N. Y.
For page see List of Advertisers.

A. T. Stearns Lumber Co., Neponset, Boston.

For page see List of Advertisers.

King Construction Co., N. Tonawanda, New York

For page see List of Advertisers.

J. C. Moninger Co., 117 East Blackhawk St. Chicago, Ill.

For page see List of Advertisers.

Foley Mfg. Co., Western Ave., between 25th & 26th Sts., Chicago.

For page see List of Advertisers.

GREENHOUSE BUILDING MATERIAL -- Continued

I. Cassidy, Summer Ave. and Erie R. R., Newark, N. J.

For page see List of Advertisers.

Geo. B. Doane, 18 Midway St., Boston. Iron Pipe.

For page see List of Advertisers.

S. Jacobs & Sons, 1365-79 Flushing Ave. Brooklyn, N. Y.

Metropolitan Material Co., 1398-1408 Metropolitan Ave., Brooklyn, N. Y.

For page see List of Advertisers.

GREENHOUSE CONSTRUCTION

GREENHOUSE CONSTRUCTION, Semi Iron Greenhouse, New Truss Houses and Iron Frame Houses. Lord & Burnham, 1133 Broadway, N. Y.

J. A. Payne, 260-274 Culver Ave., Jersey City, N. J.

For page see List of Advertisers.

I. Cassidy, Summer Ave. and Erie R. R., Newark, N. J.

For page see List of Advertisers.

Foley Mfg. Co., Western Ave., between 25th & 26th Sts., Chicago.

For page see List of Advertisers.

GUTTERS

GUTTERS, Cast Iron Gutters, L. & B. Improved V Shaped Gutter with drip gutter attachment. Lord & Burnham, 1133 Broadway, N. Y.

HAIL INSURANCE

Florists' Hall Assn. of America.
J. G. Esler, Saddle River, N. J.
For page see List of Advertisers.

HARDY FERNS AND SUPPLIES

H. M. Robinson & Co., 15 Province St. and 9 Chapman Pl., Boston, Mass.
For page see List of Advertisers.

Michigan Cut Flower Exchange,
38 and 40 Broadway, Detroit, Mich.
Fancy Ferns.

For page see List of Advertisers.

HART'S HANDY HANDLE

Geo. B. Hart, 24 Stone St., Rochester, N. Y.
For page see List of Advertisers.

HEATING APPARATUS

Lord & Burnham Co.,
1133 Broadway, New York.

For page see List of Advertisers.

Pierson U-Bar Co., 1 Madison Sq., N. Y.
For page see List of Advertisers.

John A. Payne, 260-274 Culver Ave., Jersey City, N. J.

For page see List of Advertisers.

HEDGE PLANTS

Peter's Nursery, Knoxville, Tenn.
For page see List of Advertisers.

HELIOTROPES.

Heliotropes, 2-in., 2c.; rooted cuttings, from soil, 75c. per 100. Edwin Bishop, Roslyn, Md.

HELP FURNISHED

Thos. H. Bambrick, 34 S. 7th St., Phila.
For page see List of Advertisers.

HERBACEOUS PERENNIALS

Bay State Nurseries, No. Abington, Mass.
For page see List of Advertisers.

New England Nurseries, Inc.,
Bedford, Mass.

For page see List of Advertisers.

P. Onwerhork, P. O. No. 2, Hoboken, N. J.
For page see List of Advertisers.

HOLLYHOCKS

Hollyhocks, separate colors, field grown, healthy stock, \$3.00 per 100; also Dahlias, novelties and standard varieties. Send for catalogue. W. W. Willmore, Box 382, Denver, Colo.

Field grown, double Hollyhocks in separate colors, \$7. J. B. Shurtleff & Son, Cushman Ave., Revere, Mass.

HOT-BED SASH

The A. T. Stearns Lumber Co., Neponset, Mass.

For page see List of Advertisers.

Pierson U-Bar Co., 1 Madison Sq., N. Y.
For page see List of Advertisers.

Lord & Burnham Co., 1133 Broadway, N. Y.
For page see List of Advertisers.

Foley Mfg. Co., Western Ave., between 25th & 26th Sts., Chicago.

HYDRANGEAS.

W. W. Edgar Co., Waverley, Mass.
For page see List of Advertisers.

F. R. Pierson Co., Tarrytown-on-Hudson, N. Y.

Hydrangea Otaksa.

For page see List of Advertisers.

Hydrangea Otaksa. We have a fine lot at 15c., 25c., 35c., 50c., 75c., \$1.00 and upwards to \$7.00 each. Wittbold Co., 1657 Buckingham Place, Chicago, Ill.

INSECTICIDES.

Nicotinide kills all greenhouse pests.
P. R. Palethorpe Co.,
Eleventh St., Owensboro, Ky.

For page see List of Advertisers.

IRISES

J. M. Thorburn & Co., 33 Barclay St., New York.

For page see List of Advertisers.

JAPANESE PLANTS

Yokohama Nursery Co., 31 Barclay St., New York.

For page see List of Advertisers.

JUMPING BEANS

Jumping Beans, \$5 per 1000, post paid. McDowell, Mexico City.

KENTIAS

A. Lenthy & Co., Roslindale, Mass.
For page see List of Advertisers.

LILIES

W. W. Edgar Co., Waverley, Mass.
For page see List of Advertisers.

G. W. West, Shelly Bay, Bermuda.
Lilium Harrisii.

For page see List of Advertisers.

LOBELIAS

Double Lobelia, Kathleen Mallard, 2 1/2 in., 4c. Strong cuttings from soil, all full of buds and bloom. J. L. Stone, Trumansburg, N. Y.

MASTICA

F. O. Pierce Co., 12 W. Broadway, New York.

For page see List of Advertisers.

MEMORIAL DAY SUPPLIES

Welch Bros., 236 Devonshire St., Boston.
For page see List of Advertisers.

H. M. Robinson & Co., 15 Province St., Boston.

For page see List of Advertisers.

MOON VINES

Godfrey Aschmann, 1012 W. Ontario St., Philadelphia.

For page see List of Advertisers.

MYRTLE

Myrtle for cemetery planting, strong field grown clumps, \$2.00 per 100, or \$17.50 per 1000. Geo. A. Dhanau, East Walnut Hills, Cincinnati, O.

NEW AND RARE PLANTS

Rose Hill Nurseries, New Rochelle, N. Y.
For page see List of Advertisers.

NICO-FUME

Kentucky Tobacco Product Co.,
Louisville, Ky.

For page see List of Advertisers.

NURSERY STOCK

John Waterer & Sons, Ltd.,
American Nursery, Bagshot, England.

For page see List of Advertisers.

New England Nurseries, Bedford, Mass.
Shrubs, Roses and Herbaceous Perennials.
Specimen Pyramidal Box.

For page see List of Advertisers.

For List of Advertisers See Page 709

NURSERY STOCK — Continued

Bay State Nurseries, N. Abington, Mass.
Herbaceous Perennials, Hardy Ornamental Trees.

For page see List of Advertisers.

Clary's Horticultural Co., 62 Vesey St., New York.

For page see List of Advertisers.

P. Ouwerkerk, 216 Jane St., Weehawken Heights, N. J.

Holland Nursery Stock for Forcing.

For page see List of Advertisers.

American Nursery Co., 150 Broadway, New York, N. Y.

For page see List of Advertisers.

Peter's Nursery Co., Knoxville, Tenn.
Live Fence; Amoor and California Privet.

For page see List of Advertisers.

ORCHID PLANTS

Lager & Hurrell, Summit, N. J.

For page see List of Advertisers.

Sander, St. Albans, England.
Importers, Exporters, Growers, Hybridists

For page see List of Advertisers.

Julius Roehrs Co., Rutherford, N. J.

For page see List of Advertisers.

Carrillo & Baldwin, Secaucus, N. J.

For page see List of Advertisers.

Jos. A. Manda, 191 Valley Road, W. Orange, N. J.

For page see List of Advertisers.

Ordonez Bros., Madison, N. J., Box 106.

For page see List of Advertisers.

PALMS

A. Leuthy & Co., Perkins St. Nurseries, Roslindale, Mass.

For page see List of Advertisers.

Robert Craig Co., Market and 49th Sts., Philadelphia, Pa.

For page see List of Advertisers.

August Rolker & Sons, 31 Barclay St., New York.

For page see List of Advertisers.

Kentia, Phoenix, etc., all sizes. Write for new price list. Julius Roehrs Co., Rutherford, N. J.

PAINT AND PUTTY

PAINT AND PUTTY: Ideal Greenhouse lead; Special Greenhouse Putty. Lord & Burnham, 1133 Broadway, N. Y.

PANSIES

L. E. Coburn, 241 Ferry St., Everett, Mass.

250,000 Pansies, superb strain, ready now. Fall transplanted pansies, in bud and bloom. A trial order will convince you that these are the best you ever handled. \$1.25 per 100; \$10.00 per 1000. Cash with order. Leonard Cousins, Jr., Concord Junction, Mass.

PATENTS

Siggers & Siggers, Washington, D. C.

For page see List of Advertisers.

PEAT

Orchid peat, Rotted peat, Azalea peat, Leaf-Mould, Live Sphagnum moss, Baled Sphagnum moss, Green Clump moss, etc. Jobbers' list on application. C. W. Brownell & Co., Walden, N. Y.

PELARGONIUMS

R. Vincent, Jr. & Sons Co., White Marsh, Maryland.

For page see List of Advertisers.

PEONIES

Wholesale Peony list for fall 1908 is now ready. J. F. Rosenfield, West Point, Neb.

One of the finest collections in America. Send 25 cts. in stamps for new edition of Peony Manual. C. S. Harrison's Select Nursery, York, Neb.

PHLOXES

Send 25 cts. in stamps for Phlox Manual. Fine mixed phloxes \$1.50 per 100. C. S. Harrison's Select Nursery, York, Neb.

PIPE AND FITTINGS

Foley Mfg. Co., between Western Ave. and 26th St., Chicago, Ill.

For page see List of Advertisers.

PIPE AND FITTINGS. Cast Iron and Wrought Pipe, Valves, Elbows, Pipe Hooks, Automatic Air Headers, etc. Lord & Burnham, 1133 Broadway, N. Y.

PLANT STAKES AND TRELLISES

Seele's Patent, for roses, chrysanthemums, gladioli, tuberoses, dahlias tomatoes, egg plants, etc. H. D. Seele & Sons, Manuf., Elkhart, Ind.

PLANT TUBS

Henry A. Dreer, 714 Chestnut St., Phila.

POT HANGERS

Pot hangers, Kramer's \$1 doz. by exp., \$1.25 by mail. I. N. Kramer & Son, Cedar Rapids, Ia.

PRIMULA SEED

H. E. Fiske Seed Co., 13 Faneuil Hall Sq., Boston.

For page see List of Advertisers.

O. V. Zangen, Hoboken, N. J.

For page see List of Advertisers.

RAFFIA

Raffia (colored), 20 beautiful shades. Samples free. R. H. Comey Co., Camden, N. J.; 810 Washburn Ave., Chicago, Ill.

RETAIL FLORISTS

Park Floral Co., Denver, Colo.

For page see List of Advertisers.

George H. Cooke, Washington, D. C.

For page see List of Advertisers.

Gude Bros. Co., 1214 F St., Washington, D. C.

For page see List of Advertisers.

Atlanta Floral Co., Atlanta, Ga.

For page see List of Advertisers.

M. C. & J. E. Hauawirih, 232 Michigan Ave., Chicago.

For page see List of Advertisers.

William J. Smyth, Michigan Ave. and 31st St., Chicago.

For page see List of Advertisers.

George Wittbold Co., 1657-59 Buckingham Place, Chicago.

For page see List of Advertisers.

Jacob Schulz, 644 4th Ave., Louisville, Ky.

For page see List of Advertisers.

Thos. F. Galvin, 124 Tremont St., Boston.

For page see List of Advertisers.

Julius A. Zinn, 2 Beacon St., Boston.

For page see List of Advertisers.

Houghton & Clark, 396 Boylston St., Boston.

For page see List of Advertisers.

Sidney Hoffman, 59-61 Massachusetts Ave., Boston.

For page see List of Advertisers.

Edward MacMullin, 194 Boylston St., Boston.

For page see List of Advertisers.

J. Brettmeyer's Sons, Detroit, Mich.

For page see List of Advertisers.

Samuel Murray, 1017 Broadway, Kansas City, Mo.

For page see List of Advertisers.

Wm. L. Rock Flower Co., 1116 Walnut St., Kansas City, Mo.

For page see List of Advertisers.

Fred C. Weber, 4326 Olive St., St. Louis, Mo.

For page see List of Advertisers.

J. N. Champlin & Co., 1026 Chapel St., New Haven, Conn.

For page see List of Advertisers.

H. G. Eyles, 11 N. Pearl St., Albany, N. Y.

For page see List of Advertisers.

David Clarke's Sons, 2139-2141 Broadway, New York.

For page see List of Advertisers.

W. H. Donohoe, 17 E. 28th St., New York.

For page see List of Advertisers.

Alex. McConnell, New York.

For page see List of Advertisers.

M. A. Bowe, 1294 Broadway, New York.

For page see List of Advertisers.

Robert G. Wilson, Fulton St. and Greene Ave., Brooklyn, N. Y.

For page see List of Advertisers.

Thomas Young, Jr., 500 Fifth Ave., N. Y.

For page see List of Advertisers.

Young & Nugent, 42 W. 28th St., N. Y.

For page see List of Advertisers.

J. H. Dunlop, 96 Yonge St., Toronto, Can.

For page see List of Advertisers.

RHODODENDRONS

John Waterer & Sons, Ltd., American Nursery, Bagshot, England.

For page see List of Advertisers.

P. Ouwerkerk, Hoboken, N. J.

For page see List of Advertisers.

New England Nurseries, Bedford, Mass.

For page see List of Advertisers.

Eastern Nurseries, Jamaica Plain, Mass.

Hardy Hybrid and Dwarf Rhododendrons.

For page see List of Advertisers.

ROSES

Julius Roehrs Co., Rutherford, N. J.

Rambler Rose, Newport Fairy.

For page see List of Advertisers.

New England Nurseries, Inc., Bedford, Mass.

For page see List of Advertisers.

Bay State Nurseries, N. Abington, Mass.

For page see List of Advertisers.

Robert Craig Co., Market and 49th Sts., Philadelphia, Pa.

For page see List of Advertisers.

Dingee-Conard Co., West Grove, Pa.

For page see List of Advertisers.

R. & J. Farquhar & Co.,

6 and 7 South Market Street, Boston.

For page see List of Advertisers.

Anderson & Williams, Waltham, Mass.

For page see List of Advertisers.

The E. G. Hill Co., Richmond, Ind.

Roses, Rhea Reid, American Beauty.

For page see List of Advertisers.

Poehlmann Bros. Co., Morton Grove, Ill.

Mrs. Potter Palmer, Cardinal, Beauty.

For page see List of Advertisers.

P. R. Quinlan, Syracuse, N. Y.

Killaney, Richmond, Bridesmaid.

For page see List of Advertisers.

P. Ouwerkerk, P. O. No. 2, Hoboken, N. J.

For page see List of Advertisers.

Henry A. Dreer, 714 Chestnut St., Phila.

Hardy Climbers.

Crimson Ramblers, 2 year, on own roots, extra strong, at 7 cents. Gilbert Costich, Rochester, N. Y.

Low-budded roses, No. 1, \$95.00; No. 1-2, \$65.00 1000. H. T. Jones, Elizabeth, N. J.

RUBBER PLANTS

John McKenzie, North Cambridge, Mass.

For page see List of Advertisers.

S. A. F. CONVENTION ACCOMMODATIONS

Tower Hotel, Niagara Falls, N. Y.

For page see List of Advertisers.

SALVIAS

Cohanzie Carnation Co., New London, Ct.

Salvia Splendus.

For page see List of Advertisers.

SEEDS

T. J. Grey Co., 32 So. Market St., Boston, Mass.

For page see List of Advertisers.

Joseph Breck & Sons,

51 and 52 N. Market St., Boston, Mass.

For page see List of Advertisers.

W. Atlee Burpee & Co., Philadelphia.

For page see List of Advertisers.

J. M. Thorburn & Co., 33 Barclay St., N. Y.

For page see List of Advertisers.

A. T. Boddington, 342 W. 14th St., N. Y.

For page see List of Advertisers.

H. F. Michell Co., 1017 Market St., Phila.

For page see List of Advertisers.

James Vick's Sons, Rochester, N. Y.

Vick's Superb Pansy Seed.

For page see List of Advertisers.

Hjalmar Hartmann & Co.,

12 Stormgade, Copenhagen, Denmark.

Cauliflower and Cabbage Seed.

For page see List of Advertisers.

Rickards Bros., 37 E. 19th St., New York.

For page see List of Advertisers.

R. & J. Farquhar & Co., 6-7 So. Market St., Boston.

For page see List of Advertisers.

C. C. Morse & Co., 48-56 Jackson St., San Francisco, Cal.

For page see List of Advertisers.

Braslan Seed Growers Co., San Jose, Cal.

For page see List of Advertisers.

In writing to Advertisers kindly mention Horticulture

SEEDS - Continued

H. E. Flske Seed Co., Faneuil Hall Sq., Boston. Primula Pringel Sinensis. For page see List of Advertisers. O. V. Zangon, Hoboken, N. J. For page see List of Advertisers. John F. Rupp, Shiremanstown, Pa. Chinese Primrose, Chioraria, Giant Pansy Seeds. For page see List of Advertisers. Asparagus Pl. Nanus, \$2.50 per 1000. Plant early. Asparagus Plants 14 to 18 inches high, \$5.00 per 100. Peter Mueck, Box 172, Orlando, Fla. Days Perfect and Burrell's Klondike Cucumber Seed, 85c. per pound. Finest stinging varieties grown. D. V. Burrell, Rocky Ford, Colorado.

SLUG SHOT

Hammond's Paint & S. S. Works, Fishkill-on-Hudson, N. Y. For page see List of Advertisers.

SMILAX

Smilax, choice young plants from fall; \$3.00 per 1000, 2000 for \$5.00, 5000 for \$10.00; 50c. per 100 by mail. F. A. Baller, Bloomington, Ill.

SPHAGNUM MOSS

Live Sphagnum moss, orchid peat and orchid baskets always on hand. Lager & Hurrell, Summit, N. J. Fresh, clean, 5 bbl. bale, \$1.25; 2 bales, \$2.25; 5 bales, \$5.00, 10 bales, \$9.50. Cash. H. R. Akers, Chatsworth, N. J.

SPIREA

W. W. Edgar Co., Waverley, Mass. For page see List of Advertisers.

SPRAYERS

Charles J. Jager Co., 281-85 Franklin St., Boston. For page see List of Advertisers. "Showermaker," \$1. Jos. Kopecky, So. Bend, Ind.

STEAM TRAP

E. Hippard, Youngstown, O. For page see List of Advertisers.

TO-BAK-INE

E. H. Huat, Genl. Agt., 76-78 Wabash Av., Chicago. For page see List of Advertisers.

TUBEROSES

Stump & Walter Co., 50 Barclay St., New York. For page see List of Advertisers.

VEGETABLE PLANTS

R. Vincent, Jr. & Sons Co., White Marsh, Maryland. For page see List of Advertisers. Cabbage Plants Early Jersey Wakefield, Charleston Wakefield, Early Summer, nice plants, \$1.25 per 1,000; \$10.00 per 10,000. Dwarf Erfert Cauliflower plants, \$3.00 per 1,000. Gladioli bulbs, large No. 1, fine mixture, \$4.00 per 1,000. Cash order quick. W. F. Allen, Salisbury, Md.

VENTILATING APPARATUS

Pearson U-Bar Co., 1 Madison Sq., N. Y. For page see List of Advertisers. Foley Mfg. Co., Western Ave., between 25th & 26th Sts., Chicago. For page see List of Advertisers. John A. Payne, 260-274 Culver Ave., Jersey City, N. J. For page see List of Advertisers. The Advance Co., Richmond, Ind. For page see List of Advertisers. Quaker City Machine Co., Richmond, Ind. 26th Century Ventilating Arm. For page see List of Advertisers.

VENTILATING MACHINERY, New Model encased, self-oiling gear; Standard Model Open Gear. Lord & Burham, 1133 Broadway, N. Y.

VERBENAS

Mammoth Verbenas, fine large plants from soil, coming in bud. 60c. per 100, by mail; \$4.00 per 1000, by express. Samuel Whitton, 15 Gray Ave., Utica, N. Y.

VIOLETS.

Lady Campbell violets, 25,000 extra fine, sand-rooted cuttings, \$1.00 per 100, by mail; \$7.00 per 1000, by express; 500 at 1000 rate. Satisfaction guaranteed. Field-grown plants of Campbell and California ready in August. Chas. Black, Hightstown, N. J.

Marie Louise Violet cuttings well rooted; satisfaction guaranteed, \$10.00 per 1000, until June 15. Cash with order. James Kearns, Rhinebeck, N. Y.

California violets, extra strong, healthy plants, \$1.00 per 100, \$7.00 per 1000. Fred E. Holland, Highland, Ill.

VINCAS

Edmund Reardon, Cambridge, Mass. Vinca Minor. For page see List of Advertisers. 4-inch Vinca Variegata at \$10 per 100. Joseph Labo, Joliet, Ill. Vinca Variegata, extra strong, long vines from 4 in., \$10.00 per 100; cash. Converse Greenhouses, Webster, Mass.

VIOLETS

Violet cuttings, "Marie Louisa" Rhinebeck stock, rooted runners, May delivery \$20.00 M. Wm. F. Kastling Co., 383 Elliott St., Buffalo, N. Y.

WIREWORK

Reed & Keller, 122 W. 25th St., N. Y. For page see List of Advertisers. Wirework. Write for our catalogue. Holton & Hunkel Co., Milwaukee, Wis. William E. Hellscher's Wire Works, 38-40 Broadway, Detroit, Mich. Headquarters for wire work. Send for list. Ball & Betz, 31 E. 3rd St., Cincinnati, O.

WHOLESALE FLORISTS

Boston

N. F. McCarthy & Co., 84 Hawley St., Boston. For page see List of Advertisers. H. M. Robinson & Co., 15 Province St. and 9 Chapman Pl., Boston. For page see List of Advertisers. Welch Bros., 226 Devonshire St., Boston. For page see List of Advertisers.

Buffalo

Wm. F. Kastling Co., 383-87 Elliott St., Buffalo, N. Y. For page see List of Advertisers.

Chicago

Chas. W. McKellar, 51 Wabash Ave., Chicago. For page see List of Advertisers. Peter Reinberg, 51 Wabash Ave., Chicago. For page see List of Advertisers. E. F. Waterson Co., 45-49 Wabash Ave., Chicago. For page see List of Advertisers. J. A. Budlong, 37-39 Randolph St., Chicago. For page see List of Advertisers.

Detroit

Michigna Cut Flower Exchange, 38 and 40 Broadway, Detroit, Mich. For page see List of Advertisers

Minneapolis

Rice Bros., 115 N. 6th St., Minneapolis, Minn. For page see List of Advertisers.

New York

J. K. Allen, 106 W. 28th St., New York. For page see List of Advertisers. J. S. Fenrich, 110 W. 28th St., New York. For page see List of Advertisers. Ford Bros., 48 W. 28th St., New York. For page see List of Advertisers. H. E. Froment, 57 W. 28th St., New York. For page see List of Advertisers. Alex. J. Guttman, 34 W. 28th St., New York. For page see List of Advertisers. E. C. Horan, 55 W. 28th St., New York. For page see List of Advertisers. A. H. Langjahr, 55 W. 28th St., New York. For page see List of Advertisers. James McManns, 42 W. 28th St., New York. For page see List of Advertisers. John I. Raynor, 49 W. 28th St., New York. For page see List of Advertisers. W. F. Sheridaa, 39 W. 28th St., New York. For page see List of Advertisers. Traendly & Scheuck, 44 W. 28th St., New York. For page see List of Advertisers.

John Young, 51 W. 28th St., New York. For page see List of Advertisers.

Moore, Hentz & Nash 55 and 57 W. 26th St., New York. For page see List of Advertisers.

Frank S. Hicks & Co., 39 W. 28th St., New York. For page see List of Advertisers.

Wm. H. Kuebler, 28 Willoughby St., Brooklyn, N. Y. For page see List of Advertisers.

Phillip F. Kessler, 55 and 57 W. 26th St., New York. For page see List of Advertisers.

A. Moitz, 55-57 W. 26th St., New York. For page see List of Advertisers.

B. S. Sloan, Jr., 55 W. 26th St., New York. For page see List of Advertisers.

Philadelphia

W. E. McKissick, 1619-1621 Ranstead St., Philadelphia, Pa. For page see List of Advertisers.

Leo Nlessen Co., 1209 Arch St., Philadelphia, Pa. For page see List of Advertisers.

The S. S. Pennock-Meehan Co., 1608-18 Ludlow St., Philadelphia, Pa. For page see List of Advertisers.

Edward Reid, 1528 Ranstead St., Philadelphia, Pa. For page see List of Advertisers.

Pittsburg

J. B. Murdoch & Co., 714 Penn Ave., Pittsburg, Pa. For page see List of Advertisers.

St. Louis

H. G. Berning, 1402 Pine St., St. Louis, Mo. For page see List of Advertisers

WHOLESALE PLANTSMAN

Samuel A. Woodrow, 53 W. 30th St., New York. For page see List of Advertisers.

WILD SMILAX

E. A. Beaven, Evergreen, Ala. Southern Wild Smilax: Log Mosses. For page see List of Advertisers.

SPECIAL SURPLUS LIST
These prices holding good only until present surplus is reduced).
Begonia Rex, fine collection of varieties, Per 100 \$3.00
Begonia Thurstoni and T. Daw 2.50
Fuchsias, strong stock, 8 varieties 2.50
Violet, Prince of Wales 2.50
Verbenas, all colors 2.50
Pandanus Urtis, 1/2 in. 4.00
Pandanus Urtis, 4 in. 5.00
Kaiserin Roses, Fresh propagation 5.00
Baby Rambler Rose \$2.00
Clothilde Souper Rose 2.50
Salvia Splendens 2.50
Ivy Geraniums 2.50
Dracena Indivisa 2.50
Pelargoniums, 3 in. 10.00
Digitals, two colors, field grown 4.00
Campanula in variety, field grown 4.00
Shasta Daisy, in variety, field grown 3.00
THE STORRS & HARRISON CO., Painesville, Ohio

List of Advertisers

Advance, The Co. 711	Lager & Hurrell 697
Allen J. K. 702	Langjahr, Alfred H. 702
Altimo Culture Co. 695	Lewis A. F. Mfg. Co. 699
American Nursery ... 684	Leuthy A. & Co. 693
American Nursery Co. 684	Lord & Burnham Co. 712
Anderson & Williams, 693	Littlefield H. F. 683
Aschmann G. 697-693	Lutton W. H. 711
Atlanta Floral Co. 699	Manda Jos. A. 697
Bambrick Thos. H. 709	MacMullen E. A. 699
Barrows H. H. & Son. 697	McCarthy N. F. & Co. 703
Bayersdorfer H. & Co. 682-700	McConnell Alex. 698
Bay State Nurseries. 684	McKellar Charles W. 700
Beaven E. A. 701	McKenzie John. 697
Bernig H. G. 703	McKissick, W. E. 700
Boddington A. T. 667	McManus Jas. 702
Boston Florist Letter Co. 703	Metropolitan Material Co. 711
Boston Plate and Window Glass Co. 709	Michell H. F. Co. 695-696
Bosch, Felix. 697	Michigan Cut Flower Exchange. 703
Bostrom-Brady Mfg. Co. 701	Milling Bros. 703
Bowe, M. A. 698	Mitting, A. 693
Braslan Seed Growers Co. 695	Moltz, A. 703
Breck Joseph & Sons 695	Mooring J. C. 711
Breitmeier's J. Sons. 698	Moore, Hentz & Nash 702
Bridgeman's Seed Warehouse. 695	Morse C. C. & Co. 695
Budlong J. A. 700	Murdoch J. B. & Co. 700
Burpee W. A. & Co. 695	Murray Samuel. 698
Cameron H. L. 683	New Englad Nursery Series. 683
Carrillo & Baldwin. 697	Niessen Leo Co. 700
Cassidy J. 711	Oak Hill Nurseries. 684
Castle Co. 710	Ordonez Bros. 697
Champion J. N. & Co. 699	Ouwkerk P. 683
Chicago Carotation Co. 692	Palethorpe P. R. Co. 696
Clarke's David, Sons 698	Park Floral Co. 698
Clary's Horticultural Co. 703	Parshelsky Bros. 709
Cohanzie Carnation Greenhouses. 692	Payne John A. 709
Conard & Jones Co. 693	Pennock-Meehan Co. 700
Cooke G. H. 698	Perkins St. Nurseries. 693
Craig, Robt. Co. 692	Peter's Nursery Co. 683
Dingee & Conard Co. 684	Pierce F. O. Co. 710
Doane Geo. B. & Son 711	Pierson, A. N. 692
Donohoe W. H. 698	Pierson F. R. Co. 684
Dorner F. Sons & Co. 692	Pierson U Bar Co. 712
Dreer H. A. 683-710-711	Peehlman Bros. Co. 684
Dunlop John H. 699	Pulverized Manur. Co 710
Dysart R. J. 699	Quaker City Machine Co. 711
Eastern Nurseries. 684	Quinlan P. R. 692
Edgar, W. W. Co. 693	Rawson W. W. & Co. 696
Edwards Folding Box Co. 700	Raynor John I. 702
Eldering W. J. & Son, 667	Reardan Edmund. 683
Elliott Wm. & Sons. 694	Reed & Keller. 700
Esler J. G. 711	Reid Edw. 700
Ernest W. H. 710	Reinberg Peter. 700
Eyres. 698	Rice Bros. 700
Farquhar R. & J. & Co. 683	Richard's Bros. 695
Fenrich J. S. 702	Robinson H. M. & Co. 691-703
Fisher, Estate of David. 692	Rock Wm. L. Flo. Co. 698
Fiske, H. E. Seed Co. 695	Roehrs Julius Co. 684-697
Foley Mfg. Co. 682	Roher Albert. 692
Ford Bros. 702	Roland, Thomas. 693
Froment H. E. 702	Rolker August & Sons Co. 697-710
Frost H. L. & Co. 684	Rose Hill Nurseries. 693
Galvin Thos. F. 699	Rupp J. F. 695
Graham Hugh Co. 697	Sander & Son. 697
Graham Wm. Co. 702	Schulz Jacob. 698
Grey T. J. Co. 695	Scott, John. 697
Gude Bros. Co. 698	Sharp, Partridge & Co 711
Guttman Alex. J. 702	Sheridan W. F. 702
Haerens A. 697	Siggers & Siggers. 710
Hall Asso. 711	Situations & Wants. 704
Haines, J. E. 692	Skidelsky S. S. 692
Hammond Paint & Slug Shot Works. 696	Smyth Wm. J. 698
Hart, Geo. B. 699	Standard Plate Glass Co. 711
Hartmann Hjalmar & Co. 695	Stearns A. T. Co. 711
Hauswirth M. C. & J. E. 698	Storrs & Harrison. 708
Heacock Joseph. 692	Stump & Walter Co. 693-696
Herbert David & Son. 692	Thorburn J. M. & Co 695
Herzog Wm. S. 692	Totty Chas. H. 683
Hews A. H. & Co. 710	Tower Hotel. 700
Hicks Frank S. & Co 703	Traendly & Scheock. 702
Hillfinger Bros. 710	Valentine, J. A. 698
Hill, The E. G. Co. 684	Velthuis K. 697
Hippard F. 710	Vick's Jas. Sons. 695
Hoetig M. J. 710	Vincent R. Jr. & Sons. 693-694
Hoffman. 699	Waterer John & Sons 684
Horan E. C. 702	Weathered Co. 712
Houghton & Clark. 699	Weber F. C. 698
Huol E. H. 696	Welch Bros. 689-700
Illinois Heating & Mfg. Co. 699	West Geo. W. 697
Jager, Chas. J. Co. 696	Wilson. 698
Kasting W. F. 699-703	Winterson, E. F. Co. 700
Kentucky Tobacco Product Co. 696	Witthold Geo. Co. 699
Kessler, P. F. 702	Woodman E. & C. 693
King Cons. Co. 711	Woodrow, Sam'l A. 703
Kroeschell Bros. Co. 710	Yokohama Nursery Co 693
Kuebler Wm. H. 703	Young John. 702
	Young, Thos. Jr. 698
	Young & Nugent. 698
	Zangen O. V. 695
	Zinn J. A. 699
	Zirngiebel Denys. 693
	Zvolanek A. C. 695

New Offers in This Issue.

BEDDING PLANTS. Wm. S. Herzog, Morris Plains, N. J. For page see List of Advertisers.
BOARD FILE FOR ORDERS. A. F. Lewis & Co., E. Boston, Mass. For page see List of Advertisers.
CANNAS. Estate of David Fisher, Woburn, Mass. For page see List of Advertisers.
CURVED ICELESS EAVE. Wm. H. Lutton, West Side Avenue Sta., Jersey City, N. J. For page see List of Advertisers.
DRACAENAS, VINCAS, CANNAS. E. & C. Woodman, Danvers, Mass. For page see List of Advertisers.
GARDENIA VEITCHI. Hugh Graham Co. (David Rust, Receiver), 104 S. 13th St., Phila. For page see List of Advertisers.
GREENHOUSE GLASS. Sharp, Partridge & Co., 23d & Lumber St., Chicago For page see List of Advertisers.
GLASS SPECIAL OFFER. Parshelsky Bros., 50 Montrose Ave., Brooklyn, N. Y. For page see List of Advertisers.
HOME-GROWN PALMS. Joseph Heacock Co., Wynedo, Pa. For page see List of Advertisers.
MEMORIAL DAY SUPPLIES. H. Bayersdorfer & Co., 1129 Arch St., Philadelphia. For page see List of Advertisers.
MYOSOTIS. Denys Zirngiebel, Needham, Mass. For page see List of Advertisers.
ORCHIDS, NEW IMPORTATIONS. Ordonez Bros., Madison, N. J. For page see List of Advertisers.
POTTED ROSES. Henry A. Dreer, 714 Chestnut St., Phila. For page see List of Advertisers.
SELF WATERING FLOWER BOXES FOR WINDOWS, PORCHES AND CEMETERIES. Illinois Heater & Mfg. Co., 2946 Wentworth Ave., Chicago, Ill. For page see List of Advertisers.
SHEEP MANURE. H. A. Dreer, 714 Chestnut St., Phila., Pa. For page see List of Advertisers.
WINTER FLOWERING SWEET PEAS. A. C. Zvolanek, Bound Brook, N. J. For page see List of Advertisers.
SITUATIONS WANTED

GOOD MEN

When you need good men, skilled or unskilled, Write:

THOS. H. BAMBRICK

34 South 7th Street Philadelphia

Help of all kinds, including that for Florists, Nurserymen, Seedsmen and the Horticultural trade generally.

John A. Payne

Greenhouse Designer and Builder
260-274 Culver Ave., Jersey City, N. J.
Purlins



The PAYNE "Grip-tight Fitting"

Pipe Tee

Column

for purlins and columns, is the strongest and most secure fitting yet produced for this purpose, because it is held fast by two bolts where the greatest grip is required. They cannot break because the bolts are close to edge of pipe.

Iron and Wood Frame Greenhouses of every type. Material only or erected.

Let us estimate on your requirements.

Everything for the Greenhouse

BOSTON PLATE & WINDOW GLASS CO.
GREENHOUSE GLASS
German and American
261 to 287 A St., Boston 20-22 Canal St.

HELP WANTED

TRAVELLER WANTED

by leading import house handling all kinds of foreign nursery and florists' stock—excepting Dutch Bulbs. Splendid opening for young man (under 25) with energy, judgment, intelligence and a fair knowledge of the business.
State age, qualifications and salary expected to "Import," care of Horticulture.

FOR SALE

GREENHOUSE FOR SALE.

About 14,000 feet of glass, two steam boilers, one hot water; easy communication to Boston and New York, 1-4 mile to depot; trolley freight passes greenhouses. Three acres of land, large two-story dwelling house, large wholesale and retail business. Books open for inspection. Ill health reason for selling. Address Horticulturist, care of HORTICULTURE.

FOR SALE—On account of my husband's death, desirable greenhouse plant; large and increasing demand for funeral designs, bouquets and bedding stuff; a dwelling house, 10,000 feet of glass; a paying business; place is stocked. Mrs. Kathrine Tully, 47 Spring Forest Ave., Binghamton, N. Y.

FOR SALE Florist store, good paying business, good location for landscape gardening. Good reason for selling. Inquire, Florist, 1480 Flatbush Avenue, Brooklyn, N. Y.

WANTED To sell or rent a greenhouse property of 25,000 sq. ft. of glass. Or would consider taking a single man as partner. Must be an expert grower of Carnations and have some capital. Address Carnation, care HORTICULTURE.

FOR SALE Special—Glass for sale below cost, 16 x 24 double thick American A. & B. qualities, below cost, for immediate acceptance. Never such an opportunity offered before. Write Parshelsky Bros., 50 Montrose Ave., Brooklyn, N. Y.

Facts You Should Know

FUEL ECONOMY

depends first upon **PERFECT** boiler construction and **CLEAN** heating surfaces in the boiler. Every part is accessible in the

KROESCHELL BOILER

The tubes are cleaned from the front at any time and can be done as easily as firing the boiler. All the soot drops under the boiler in the rear, and out of the way, making no dirt in the boiler room. All the rest of the heating surface in the Kroeschell Boiler is **self cleaning**; this can be said of no other type of boiler.

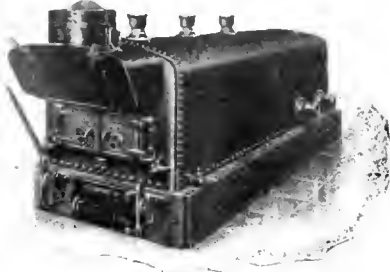

The peculiar construction of our boiler causes many **thin water** ways in direct contact with the fire, making the most powerful and **rapid heater** and water circulator known. This means a **saving of fuel**; many of our customers claim a saving, from actual test, of from **one-fourth to one-third on their fuel bills**. Any kind or grade of fuel can be used in **The Kroeschell Boiler**, hard coal, soft coal, wood or gas. Fully 90% of our customers use the very **cheapest mine run soft coal**, with excellent results.

KROESCHELL BROS. CO., 35 ERIE ST., CHICAGO

The ELECTRIC CIRCULATOR

Is master of the situation.

It **MAKES** the water circulate.

It ensures uniform temperature.

Its work is positive regardless of weather.

It never gets out of order.

It saves coal.

It is serviceable in old houses.

It is helpful in new houses.

Its value has been fully demonstrated.

Its economy is conceded.

Lower values on greenhouse products make necessary lower running expenses. Write to us today and we will send you full information as to what the Circulator can do for you, and what it will cost.

THE CASTLE COMPANY

Heating Engineers

170 Summer St., Boston, Mass.



STANDARD FLOWER POTS

Packed in small crates, easy to handle.

	Price per crate	Price per crate	
5000 2 1/4 in. pots in crate	\$4.88	1200 7 in. pots in crate \$4.20	
1500 2 1/4 " " " "	5.25	600 8 " " " " 3.00	
1500 2 3/4 " " " "	6.00	HAND MADE	
1000 3 " " " "	5.00	48 9 in. pots in crate	\$3.60
800 3 1/2 " " " "	5.80	48 10 " " " "	4.80
500 4 " " " "	4.50	24 12 " " " "	3.60
320 5 " " " "	4.51	24 12 " " " "	4.80
144 6 " " " "	3.16	12 14 " " " "	4.80
		6 16 " " " "	4.50

Seed pans, same price as pots. Send for price list of Cylinders for Cut flowers, Hanging Baskets, Lawn Vases, etc. Ten per cent. off for cash with order. Address **Hilfinger Bros., Pottery, Fort Edward, N. Y.** August Rolker & Sons, Agts., 81 Barclay St., N. Y. City.

Standard Flower . . POTS

If your greenhouses are within 500 miles of the Capitol, write us, we can save you money

W. H. ERNEST

23rd and M Street WASHINGTON D. C.

THE STANDARD STEAM TRAP

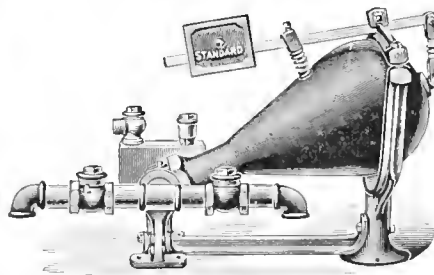

Is acknowledged the best for the florist, because It is durable and does its work without trouble and annoyance, saving its cost by the economy in coal bills.

E. HIPPARD

YOUNGSTOWN, OHIO

PATENTS

Trademarks and Copyrights

Send your business direct to Washington. Saves time and insures better service. Personal attention guaranteed. Twenty-five years' active service. SPECIALTY: "Working on the Failure of Others."

SIGGERS & SIGGERS

PATENT LAWYERS

Box 9, National Union Building
Washington, D. C.



DREER'S SHEEP MANURE

(WIZARD BRAND)
FLORIST 100 lbs., \$1.75; 500 lbs., \$8.00;
SPECIALTIES 1,000 lbs., \$15.00; Ton, 2,000 lbs., \$30.00.
HENRY A. DREER, 714 Chestnut St., Phila., Pa.



Cattle Manure In Bags

Shredded or Pulverized

Best and safest manure for florists and greenhouse use, absolutely pure, no waste, no danger. Write for circulars and prices.

The Pulverized Manure Co.,
31 Union Stock Yards, Chicago



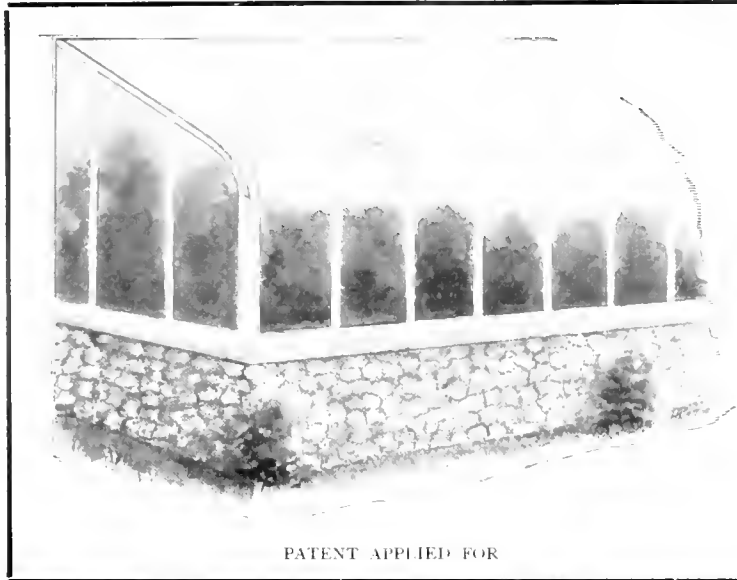

PATENT APPLIED FOR

Why My New Curved Iceless Eave is Far Superior to Anything on the Market Today

- 1st. No sash bars incased in iron, thereby eliminating all danger of bars decaying.
- 2nd. Can be used in conjunction with iron frame construction, thereby doing away with that very objectionable feature, "columns."
- 3rd. Roof bars with drip grooves, which act as conductors to carry away the condensation: Result, the driest roof ever used for greenhouse purposes.
- 4th. **THE MOST IMPORTANT OF THEM ALL.** The very small increase in cost over the ordinary style of construction which makes it possible to be used for commercial as well as private purposes.

William H. Lutton, Horticultural Architect and Builder
West Side Ave Station (C.R.R. of N.J.) Jersey City, N.J.

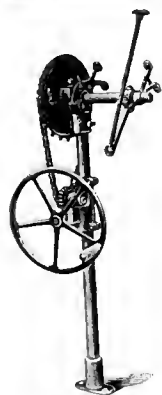

The Advance Ventilating Apparatus

A machine that does the work easily, that lasts a life time, that is very easily set up, is what makes our line so popular and what brings us the orders. Cost of a house ranges from \$13.00 upwards, depending upon the number of sash &c. Get our estimates. Give us a trial and know that we have the goods that do the work.

The Advance Co.
RICHMOND, IND.

STANDARD PLATE GLASS CO.

Manufacturers—Importers—Jobbers

NOW IS THE TIME TO BUY

FRENCH OR AMERICAN GREENHOUSE GLASS

LOWEST PRICES ON REQUEST

26-30 Sudbury St. BOSTON, MASS. 61-63 Portland St.

GLASS Always Write Us Before Buying
SHARP, PARTRIDGE & CO.
22nd and Lumber Streets, CHICAGO
WE HAVE SOME SNAPS

IRON PIPE

SECOND HAND

WROUGHT IRON PIPE, for Steam, Water, Gas or Oil, Fences or Posts. All Sizes. Price Low.

GEO. B. DOANE & SON
18 Midway Street, BOSTON
Telephone, Main 4419

CYPRESS SASH BARS 32 feet or longer
HOT BED SASH
PECKY CYPRESS BENCH LUMBER

GREENHOUSES

ERECTED AND EQUIPPED COMPLETE IF DESIRED

Write for Circular "D" and Prices

The A. T. STEARNS LUMBER CO.
NEPONSET, BOSTON, MASS.

In writing advertisers kindly mention HORTICULTURE.

I. CASSIDY

Designer and Builder of

Iron and Wood Greenhouses

Factory: Summer Ave and Erie R. R.
Newark, N. J.

R. TONAWANDA, N.Y.

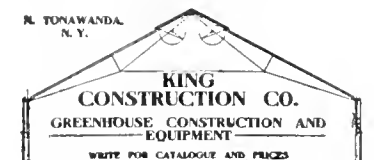

SPECIAL GLASS

Greenhouse and Hot Bed

16 x 24 A and B DOUBLE
BELOW COST

Immediate Acceptance

Write for Our Price

PARSHELSKY BROS.

59 Montrose Ave., BROOKLYN, N. Y.

METROPOLITAN MATERIAL CO.

GREENHOUSE WRECKERS

GLASS Look at these prices. New American 50 ft. to the box, 10 x 12 single \$1.60 per box, 10x12, 12x12 B. double \$2.00 per box, 12x14 to 12x20, 14x14 to 14x20, 16x16 and 16x18 B. double at \$2.15 per box, and 16x20, 16x24, 12x24 B double \$2.26 per box. Discount on large quantities. Let us quote you on

CYPRESS MATERIAL HOTBED SASH BOILERS PIPE FITTINGS HOTBED FRAMES MATS

1398-1403 METROPOLITAN AV., BROOKLYN, N. Y.

GREENHOUSE CONSTRUCTION LUMBER

John C. Moninger Co.
117 E. Blackhawk St., CHICAGO



Evans 20th Century Arm

Will not twist your shafting pipe. Give it a trial and you will use no other. Three times the power of elbow arms.

Write for Catalogue

QUAKER CITY MACHINE CO.
Richmond, Ind.

Holds Glass Firmly

See the Point

PEERLESS

Glasing Points are the best. No rights or lefts. Box of 1,000 points 75 cts. postpaid.

HENRY A. DREER,
714 Chestnut St., Phila., Pa.

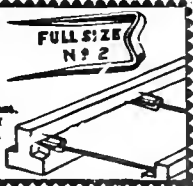

The FLOBRISTS' HAIL ASSOCIATION OF AMERICA, insurer of 28,000,000 sq. ft. of glass. For particulars address **John C. Esler, Sec'y, Saddle River, N. J.**

SAVES 25% TO 30% IN FUEL
 Burns Pea or No. 1 Buckwheat Coal. Requires attention only once a day in ordinary weather (twice in severe). Write for catalogue and reason why every florist should use the

SPENCER—
The Heater that Thinks!
WEATHERED COMPANY

Sole Agents
Box 789, NEW YORK CITY
 Main Office and Works:
 Orient and West Side Avenue,
 JERSEY CITY, N. J.

Don't forget our Greenhouse Building Catalogue. Every type of house erected complete, or material only.

THERE ARE SOME THINGS SO PERFECTLY EVIDENT THAT WHEN YOU TAKE THE TIME TO THINK THEM OVER

you can't see for the life of you why they hadn't occurred to you that way before—and that is exactly the way our boiler man feels about the merits of a cast iron boiler, over the wrought one. You see he has just returned from a three weeks trip, and found out some mighty interesting things, strongly favoring cast iron boilers. So if you are thinking of a wrought boiler, let him give you some points. If you want any kind of boiler write to him anyway. Send for the new catalog too.

WE MAKE EVERY PART OF A GREENHOUSE PUT THE GLASS. WE SELL ANY PART.

LORD & BURNHAM CO.
 MAIN SALES OFFICE:
 1133 BROADWAY, NEW YORK

BOSTON: 819 Tremont Building
 PHILADELPHIA: 1215 Filbert St.



THEY ARE ENDURING

Every part protected from decay, every iron part galvanized against rust — no points where condensation settles. Expansion and contraction perfectly adjusted. To their endurance, add attractiveness, great strength, lightness, increased productiveness, simplicity and low cost of maintenance.

The ideal construction for private estates, parks, public institutions and florists' showrooms

SEND FOR CATALOG

U-BAR GREENHOUSES

PIERSON
 DESIGNERS AND BUILDERS



U-BAR CO.
 1 MADISON AVE., NEW YORK

HORTICULTURE

Vol. VII. MAY 30, 1908 No. 22



BRIDLE PATH, WEST ROXBURY PARKWAY, BOSTON

*Devoted to the
FLORIST, PLANTSMAN,
LANDSCAPE GARDENER
and
Kindred Interests*

*Published
EVERY SATURDAY
At 11 Ham
BOSTON
Subscriptions*

**THE
FRUIT AUCTION CO.**

202-4 Franklin St., New York City

Sells DAILY, (Except Monday) at 9 a.m.

Unlimited Quantities of

PLANTS

Bedding, Ornamental ^and ^dDecorative.

BULBS

etc., etc.

Positively without reserve. In lots to suit the trade

TERMS CASH. PROMPT DELIVERY

RETURNS MADE TO GROWERS ON DAY OF SALE

*Special Preparations made for Sales
during June*

BOX 640

TEL. 1512 FRANKLIN

CORRESPONDENCE INVITED ...

Dreer's Offer of POTTED ROSES

We can still furnish the following list of Roses in good plants in 5 and 6 inch pots.

Hybrid Perpetual, Moss and other Hardy Roses.

Strong two-year-old Plants, nearly all in 6-inch pots.

	Per 100
Alfred Colomb.....	25.00
Alfred K. Williams.....	25.00
Blanche Moreau.....	25.00
Baroness Rothschild.....	25.00
Baron de Bonstetten.....	25.00
Camille Bernardin.....	25.00
Capt. Christy.....	25.00
Crested Moss.....	25.00
Comtesse de Muranais.....	25.00
Common Provence.....	25.00
Clio.....	25.00
Countess of Oxiord.....	25.00
Charles Lefebvre.....	25.00
Crimson Globe.....	25.00
Duke of Edinburgh.....	25.00
Earl of Dufferin.....	25.00
Fisher Holmes.....	25.00
Francois Michon.....	25.00
General Jacqueminot.....	25.00
Gloire de Margottin.....	25.00
Gloire de Lyonnaise.....	25.00
Gloire de Mosses.....	25.00
Her Majesty.....	25.00
Jean Liabaud.....	25.00
Mrs. R. G. Sharman Crawford.....	25.00
Mrs. John Lalng.....	25.00
Label Morrison.....	25.00
Mme. Plantier.....	20.00
Mme. Victor Verdier.....	25.00
Mme. Gabrielle Luizet.....	25.00
Marchionesse of Lorne.....	25.00
Marie Baumann.....	25.00
Nova Zembla.....	25.00
Princess Adelaide.....	25.00
Paul Neyron.....	25.00
Prince Camille de Rohan.....	25.00

	Per 100
Queen of Queens.....	25.00
Rodocanachi.....	25.00
Rugosa Red.....	15.00
White.....	15.00
Tom Wood.....	25.00
Victor Verdier.....	25.00
White Baroness.....	25.00

Baby Rambler Roses.

Pink Baby Rambler (Anchen Muller). Brilliant luminous pink; a shade that is always admired. \$3.00 per dozen; \$25.00 per 100.
White Baby Rambler (Katherina Zeimet). Pure white flowers, showing the yellow stamens very prettily, produced in large candelabra-shaped trusses. \$3.50 per dozen; \$25.00 per 100.

Hybrid Tea and Other Everblooming Roses.

	Per 100
Antoine Rivoire.....	\$20.00
Belle Siebrecht.....	25.00
Bessie Brown.....	30.00
Belle Lyonnaise.....	25.00
Caroline Testout.....	25.00
Celia (new).....	50.00
Comtesse Riza du Parc.....	20.00
Corallina.....	30.00
Countess Cairns.....	30.00
Earl of Warwick.....	25.00
Farbin Konigin.....	25.00
Frau Lila Rautenstrauch.....	25.00
Grace Darling.....	30.00
Gladys Harkness.....	30.00
Gustav Grunewald.....	25.00
G. Nabonnand.....	30.00
Hermosa.....	20.00
Mon. Edith Gilford.....	30.00
Johanne Sebus.....	25.00
Joseph Hill.....	35.00
Konigin Carolla.....	30.00

	Per 100
La France.....	25.00
La Detroit.....	25.00
Lady Battersea.....	30.00
Liberty.....	30.00
Marie Van Houtte.....	25.00
Mrs. B. R. Cant.....	20.00
Mildred Grant.....	30.00
Mme. Abel Chatenay.....	25.00
Edmee Metz.....	25.00
Jules Orolez.....	30.00
de Watteville.....	25.00
Papa Gontier.....	25.00
Pharisaer.....	30.00
Prince de Bulgarie.....	30.00
Queen's Scarlet, or Agrippina.....	20.00
Souvenir de Catherine Guillot.....	30.00
de President Carnot.....	30.00
de la Malmaison.....	25.00
The Warrior (new).....	50.00
Viscountess Folkestone.....	25.00

Rambler, Climbing and Trailing Roses.

	Per 100
Crimson Rambler.....	20.00
Gloire de Dijon.....	25.00
Philadelphia Rambler.....	20.00
Prairie Queen.....	20.00
Persian Yellow.....	25.00
Sweet Brier.....	15.00
Lord Penzance.....	25.00
Lady Penzance.....	25.00
Meg Merriles.....	25.00
Anne of Gierstein.....	25.00
Brenda.....	25.00
Trier.....	25.00
Wichuraiana Evergreen Gem.....	20.00
Pink Roamer.....	20.00
South Orange Perfection.....	20.00
Triumph.....	20.00
Universal Favorite.....	20.00
Yellow Rambler.....	20.00

HENRY A. DREER, 714 Chestnut Street, Philadelphia, Pa.

LIVE FENCES

We believe we are the largest growers of Hedge plants in America—Privet our specialty—can supply any quantity both

Amoor River and California, strong plants, at \$25.00 per M. Other varieties. Prices on application.

PETER'S NURSERY COMPANY, - Knoxville, Tenn.

Hardy Rhododendrons, Azaleas Conifers, Clematis, H. P. Roses, Shrubs and Herbaceous Plants from our **HOLLAND NURSERIES**

Prices Moderate
P. OUWERKERK, 216 Jane St., Weehawken Heights, N. J.

ROBERT CRAIG CO.

ROSES, PALMS,

and Novelties in Decorative Plants

MARKET and 49th STREETS., PHILADELPHIA, PA.

ROSES

Strong, Clean Stock. Grafted, Killarney, Richmond, Brides and Maids. \$12.00 per 100, \$110.00 per 1000.

Own Roots, Brides, Maids, Gates, Ivory, Perle, Killarney and Richmond. \$6.00 per 100, \$55 per 1000. All from 3 1/2 in. pots.
P. R. QUINLAN, Syracuse, N. Y.

DAHLIAS.

Now is the time to place your order for bulbs which will insure you getting named varieties in any quantity; prompt delivery.

DAVID HERBERT & SON,

Successors to L. K. Peacock, Inc. **ATCO, N. J.**

ROSES

100 of the best Hardy sorts.

HYBRID PERPETUALS

Finest English Grown Plants

Dozen, \$3.50; 100 \$25.00

EVERBLOOMING HYBRID TEAS

Bloom from Midsummer until frost.

Dozen \$5.00; 100, \$35.00

Hardy Climbing Roses

All the leading sorts.

Catalogue Free on Application.

R. & J. FARQUHAR & CO.

6 and 7 So. Market Street, Boston, Mass.

CHRYSANTHEMUMS

FOR IMMEDIATE ACCEPTANCE

I offer 100 Single Chrysanthemums for \$8.00, in 10 or more varieties.

100 large flowered kinds in 10 varieties for \$5.00. This will include some of the newer sorts and is a special cash offer open only to readers mentioning *Horticulture*.

CHARLES H. TOTTY, MADISON, N. J.

ROOTED CHRYSANTHEMUM CUTTINGS

Glory of the Pacific, Polly Rose, Ada Byron, Kalb, Halliday, Harry Sinclair, Bonnalfo, \$1.50 per 100.

Fair Maid Carnation Cuttings, \$1.00 per 100; \$8.00 per 1000.

H. F. Littlefield, 552 Main St., WORCESTER, MASS.

MONEY MAKERS

CHRYSANTHEMUMS—White and Yellow Bonnalfo, Ivory, Rooted Cuttings, \$10.00 per 1000. Nutt, Poitevine, Ricard and other BEST Geraniums, 4-in. stock, \$7.00 per 100.

H. L. CAMERON North Cam

CANNAS

**STARTED PLANTS in 3½ and 4-in. POTS
READY FOR IMMEDIATE PLANTING**

Mme. Nardy, Mlle. Berat, Robert Christie, Golden King, Pennsylvania, L. Patry, Florence Vaughan, Pandora, Austria, Rohallion, Pierson's Premier, Queen Charlotte, Frederick Benary, etc.

EXTRA STRONG PLANTS, \$6.00 PER 100

VINCAS AND ENGLISH IVIES

Extra fine plants in 3½ and 4 inch pots, for vases, tubs, etc.
\$8.00 per 100; extra size, \$10.00 per 100.

HYDRANGEA OTAKSA

LARGE PLANTS IN TUBS AND HALF-BARRELS FOR JULY AND AUGUST FLOWERING:

We make a specialty of these, and have a magnificent lot of large plants, which we can supply in any quantity—
from single plants up to carload lots. Large plants in tubs, \$2.00 and \$3.00 each. Extra large plants in half-barrels, \$5.00 and \$7.50 each.

- NASTURTIUMS.** Bushy plants, 3 inch pots, \$6.00 per 100.
- SALYIAS, Bon Fire.** 2¼ inch pots, \$4.00 per 100.
- AGERATUM.** 2½ inch pots, \$3.00 per 100.
- MOON FLOWERS.** 2½ inch pots, \$6.00 per 100.
- COLEUS, assorted.** 2½ inch pots, \$3.00 per 100.
- ALYSSUM, Tom Thumb.** 2½ inch pots, \$3.00 per 100.
- CROTONS, for bedding.** Extra strong plants, 3½ inch pots, \$25.00 per 100; 5 inch pots, \$50.00 per 100.
- ACALYPIA MUSAICA.** Extra choice, for bedding. 2½ inch pots, \$6.00 per 100.
- PANDANUS VEITCHII.** 5 inch pots, \$9.00 per dozen; 6 inch pots, \$12.00 per dozen; large plants, \$2.00 to \$3.50 each, according to size.
- FICUS ELASTICA.** 5 inch pots, \$4.00 per doz; 6 inch pots, \$6.00 per doz.

- DRACENA FRAGRANS.** Extra large plants, 6 inch pots, 3 feet high, \$12.00 per dozen.
- FERNS, assorted.** Extra heavy plants, 4¼ inch pots, \$3.00 per 100; 3½ inch pots, extra heavy, \$10.00 per 100.
- NEPHROLEPIS PIERSONI ELEGANTISSIMA.** 2¼ inch pots, \$6.00 per 100; 3½ inch pots, \$15.00 per 100; 6 inch pots, \$6.00 per dozen; 8 inch pots, \$12.00 per dozen.
- BOXWOOD, Pyramide.** Extra fine plants, \$2.00 and \$3.00 each.
- PANSIES, ENGLISH DAISIES, and FORGET-ME-NOTS.** \$3.00 per 100.
- CARNATIONS, Winsor and White Enchantress.** We can supply these in quantity, ready for immediate planting. Strong established plants from 2¼ inch pots, \$7.50 per 100; \$60.00 per 1000.

F. R. PIERSON CO., Tarrytown-on-Hudson, New York

The Roses that Win

MRS. POTTER PALMER, CARDINAL American Beauty and Other Standard Varieties. Rooted from Our Famous Stock. Send for Prices.

POEHLMANN BROS. CO.
Morton Grove, Ill.

ROSES

A SPECIALTY

The Dingee & Conard Co. West Grove PA.

RHEA REID

READY NOW, Own Root, \$30 per 100, Grafted, \$35 per 100.

AMERICAN BEAUTY

Fine Young Stock, \$6 per 100, \$50 per 1000.

THE E. G. HILL CO., Richmond, Ind.

AMERICAN NURSERY CO., COMBINING

FRED'K W. KELSEY, New York City
F. & F. NURSERIES, Springfield, N. J.
BLOODGOOD NURSERIES, Flushing, L. I.
N. J. & L. I. NURSERIES

We can supply your every need. Write for prices
Sales Department

150 BROADWAY, - NEW YORK

CARE OF TREES

12 years' experience. Endorsed by the United States Department of Agriculture. Graduates of Agricultural Colleges and Schools of Forestry. Field force 250 expert men. Everything to do with trees,—pruning, removing dead wood, treating and closing cavities, spraying for both insects and diseases; fertilizing, forest planting, tree moving, etc. Write us.

H. L. FROST & CO.

Landscape Foresters and Entomologists.
White Plains, N. Y. Arlington, Mass

Berberis Thunbergii

18 to 24-in., 12 to 16-in., all well branched and good roots. 10,000 Vinca Minor (Grave Myrtle). 5000 Red Oak, 3 to 5 ft. Norway Spruce 12 to 18-in.

OAK HILL NURSERIES, Roslindale Mass.

FINEST LOT OF

HARDY HYBRID RHODODENDRONS

ALSO DWARF RHODODENDRONS
ANDROMEDA FLORIBUNDA

READY FOR IMMEDIATE SHIPMENT
ORDER TODAY

EASTERN NURSERIES, JAMAICA PLAIN, MASS.

JOHN WATERER & SON, Ltd.

American Nursery, Bagshot, England

Are Specialists in the

REALLY HARDY VARIETIES

of Rhododendron Hybrids and in Select Varieties of Hardy Border Plants.

HARDY NORTHERN GROWN NURSERY STOCK

At Reasonable Prices

FRUIT AND ORNAMENTAL TREES, SHRUBS, VINES, ROSES AND
HERBACEOUS PERENNIALS IN GREAT VARIETY

Catalogue and Price List for the asking

BAY STATE NURSERIES, NORTH ABINGTON, MASS.

If you run one Greenhouse or a dozen of them

Read Carefully about

the **ELECTRIC CIRCULATOR** on Page 742.

There is Money in it for you.

Prices Quoted in these Columns are for Dealers Only. When Writing to Advertisers Please Mention HORTICULTURE.

Notes from the Arnold Arboretum

The Lilacs are now in full bloom and form the centre of attraction at the Arboretum. How much the beautiful display is appreciated by the public is shown by the great numbers of visitors who are coming daily to the Arboretum, particularly last Saturday and Sunday afternoon the driveway and the paths near the Lilacs were literally thronged with visitors afoot and in carriages. In the last issue the earliest varieties were noted and now, as all the varieties are in bloom, though the earlier are nearly past their prime, some of the best of all colors may be noted. Among the whites may be mentioned *Marie Legraye* with large panicles, one of the best single whites, early like *Alba major* and *Virginalis*, *Noisettiana*, *Madame Casimir Perier*, one of the best double whites, *Madame Lemoine*, double-flowered, late. Among the blue, lilac or pink varieties we note *Bleuetre*, almost pure pale blue, the best of the blue varieties, *Coccoloba superba*, bluish lilac, very free-flowering, *Rouen*, blue lilac, *President Grevy*, large panicles of blue lilac double flowers, *E. Lemoine*, lilac, double-flowered, *Geheimrat Heyder*, light lilac, free-flowering, and the similar *Eckholm*, *President Carnot*, pale lilac, double, late, *Pyramidalis*, lilac, double flowers in very large panicles, *Maxime Cornu*, lilac, large panicles of double flowers, *Beranger*, dark lilac flowers in large panicles, late, *Alphonse Lavalley*, pink lilac, free-flowering, *Croix de Brahy*, pink lilac, early, *Macrostachya*, large panicles of light pink flowers, *Fuerst Lichtenstein*, pale pink lilac, free-flowering, early, *Marechal de Bassompierre*, double pinkish lilac flowers in large panicles, *Comte de Kerchove*, similar to the preceding, *Gloire de Moulins*, pink flowers, one of the best pinks. Of the red and purple varieties the following are some of the best: *Congo*, dark purple, large flowers in dense, somewhat nodding panicles, late, *Andenken an L. Spaeth* (*Souvenir de Louis Spaeth*), dark purple, one of the darkest, late, *Charles Joly*, dark purple double flowers, the darkest of the double varieties, late, *Philemon*, dark purple, late, *President Massart*, purple, late, *Charles X. (Caroli)*, purple lilac, *Geheimrat Singelmann*, purplish lilac, large panicles, *Marie Kreuter*, purplish lilac, *Aline Mocqueris*, dark red, *Rubra insignis*, purplish red, *Professor Sargent*, purple lilac. Of the Persian Lilacs the red *Syringa chinensis* var. *rubra* is perhaps the best. The Lilacs of the Persica-group should never be planted together with varieties of the Vulgaris-group, as the two are too different in habit and the former with their spreading slender branches bearing nodding broad panicles would look out of place between the rather stiff upright Vulgaris-varieties. The single-flowered varieties are the best for general planting, they are more free-flowering and have not the disadvantage of the double-flowered forms that the faded individual flowers do not fall off, but remain on the panicle which gives the shrubs a very unsightly appearance, if the panicles are not removed.

Besides the Lilacs one of the showiest trees is *Cornus florida*, the Flowering Dogwood, now covered with its large white blossoms, but still more beautiful is its red variety, *C. florida* var. *rubra*, with bright pink flowers: its color effect in the landscape is about the same as that of the Red-bud, but the pink of the former is purer, more like that of the Peach; there are many fine trees of it in the shrubberies around the Jamaica Pond. Another striking tree is the Snowdrop-tree, *Halesia tetraptera* (*Mohrodendron carolinum*) covered now with its numerous bell-shaped white flowers which unfortunately do not last very long.

The flowering crab-apples take now their leave with *Malus coronaria*, the Fragrant Crab, and *M. ioensis*, the Iowa Crab, both very beautiful with their pink, fragrant flowers between the young foliage. Also Beechels Crab, *M. ioensis* var. *plena*, comes in for much admiration in account of its clusters of large double flowers looking like bunches of little pink Roses.

Most of the Bush Honeysuckles are in bloom. *Lonicera tatarica* with its varieties ranging in color from pure white to red and *L. bella* and *L. notha*, its hybrids with *L. Morrowii* and *L. Ruprechtiana*, which show the same variation in the color of their flowers, are now very attractive. A handsome species is *L. Morrowii* with pure white flowers changing to yellowish in fading: it is a rather low spreading bush of dense habit and keeps its scarlet fruits and its dark dull green foliage unchanged until late in fall: this advantage is also shown by the above named hybrids, while *L. tatarica* is apt to become unsightly earlier in fall. *Lonicera muscariensis* is a hybrid of *L. Ruprechtiana* and *L. Morrowii*, very similar to the latter, but of more upright habit. A striking variety of the western *Lonicera involucrata* with pale yellow rather insignificant flowers is *L. involucrata* var. *serotina* which has yellow flowers tinged with scarlet resembling in color and shape much those of *Manettia bicolor*. A graceful little shrub is *L. tangutica* with small but numerous pendulous pinkish white flowers and *L. syringantha* with upright pinkish white flowers; handsomer than the latter is its variety *L. syringantha* var. *Wolfii* with flowers of a deep lilac color and of a delicious fragrance reminding of Hyacinths. Both species are of recent introduction from eastern Siberia.

Of the many other shrubs which are flowering may be mentioned *Prunus maritima*, the last of the American plums to bloom, *Spiraea Vanhouttei* *Deutzia purviflora* and *D. Lemoinci* with large clusters of pure white flowers, *Rhodotypos tetrapetala* (*R. kerrioides*) with large white flowers at the end of the branches, *Xanthococcus sorbifolia* with numerous upright spikes of delicate white flowers marked yellow and red, *Viburnum prunifolium*, *Kerria japonica* with yellow single and double flowers, several species of *Berberis* with their showy golden racemes, and species of *Ribes*.

Alfred Rehder.

HORTICULTURE

VOL. VII

MAY 30, 1908

NO. 22

PUBLISHED WEEKLY BY

HORTICULTURE PUBLISHING CO.
11 Hamilton Place, Boston, Mass.

Telephone, Oxford 292
WM. J. STEWART, Editor and Manager

SUBSCRIPTION PRICE

One Year, in advance, \$1.00; To Foreign Countries, 2.00. To Canada, \$1.50

ADVERTISING RATES

Per Inch, 30 inches to page \$1.00.
Discounts on Contracts for consecutive insertions, as follows:
One month (4 times) 5 per cent.; three months (13 times) 10 per cent.;
six months (26 times) 20 per cent.; one year (52 times) 30 per cent.
Page and half page spaces, special rates on application.

Entered as second-class matter December 8, 1904, at the Post Office at Boston, Mass. under the Act of Congress of March 3, 1879.

CONTENTS

	Page
COVER ILLUSTRATION—Bridle Path, West Roxbury Parkway, Boston.	
NOTES FROM THE ARNOLD ARBORETUM—Alfred Rehder	717
THE HARDY RHODODENDRON QUESTION—Hans J. Koehler	719
NEWS OF THE CLUBS AND SOCIETIES: Connecticut Horticultural Society—Morris County Gardeners' and Florists' Society—American Peony Society—Society of American Florists—New Orleans Horticultural Society—Pennsylvania Horticultural Society—Detroit Florist Club.....	729
CLUB AND SOCIETY NOTES.....	721
AMERICAN ASSOCIATION OF NURSEYMEN.....	721
THE MOST USEFUL OF THE CATTLEYS—George E. McClure.....	722
A SIXTY MILLION FLOWER SPIKE—G. C. Watson.....	724
SPRING PULB BEDDING—Illustrations.....	724
SEED TRADE: American Seed Trade Association.....	726
OF INTEREST TO RETAIL FLORISTS: A Distributing Problem—W. H. Long.....	730
New Retail Flower Stores.....	731
FLOWER MARKET REPORTS: Boston, Chicago, New York, Philadelphia, Washington	733
OBITUARY—George McRae—E. B. Forbes—Mrs. Thomas Young	733
MISCELLANEOUS: A Correction	722
Cover Illustration	723
Hydrocyanic Gas for White Flv.....	725
Greenhouses Building or Contemplated.....	725
Spring Plant Trade in Chicago.....	725
News Notes	726-731
List of Patents.....	726
Publications Received	726
Catalogues Received	727
Incorporated	727
Business Changes	731
Personal	731
Memorial Day (Poetry).....	733

seem to have come down all at once and in every section where a progressive florist exists the orchid now receives a welcome. Mr. McClure's practical paper on this topic, which appears in this issue, is therefore very timely, selecting for consideration, as it does, the most conspicuous and useful class of orchids and imparting rational and undistorted instruction in their cultivation. The publication of the facts as to the simplicity of the requirements of this class of plants in this country should bring good results in extending their culture by the flower growers who have hitherto been deterred by the exaggerated notions heretofore disseminated as to their requirements. Indeed, it is a question whether more orchid plants have not reached the rubbish heap through the mystic coddling at the hands of the highly specialized expert than under the simple treatment of the ordinary unpretentious gardener. Our zealous growers have been too prone to base their practice with such subjects on the experience and methods in other countries, forgetting to take into account our very different climate. Instead of taking our lessons so literally from abroad American growers will do well to listen to men like Mr. McClure who have tried out our climatic conditions and, regardless of old traditions, adopted their methods accordingly.

Editor Myrick of the *New England Homestead* is out with a public address to the Governors of

the New England States calling for a development conference and urging co-operative effort to advance the material progress and development of Greater New England. He represents that these six States, isolated as they are to some extent, geographically, from the great bulk of United States territory, are so interlaced and interdependent that a closer union of sentiment and effort than has heretofore prevailed, is necessary if the land, markets, factories and other agricultural and industrial advantages which this section enjoys are to be adequately appreciated and used to best advantage. New England people have been so absorbed in the opening out and building up of the vast territory to the westward that they seem to have almost forgotten the great opportunities that lie at their own doors. The encouragement of wise forestry methods, the conservation of streams and lakes and their utilization for power or for recreation, the regulation of water and railroad transportation, the enlargement of industrial facilities, the development of better markets domestic and foreign—these are all questions to be approached in a patriotic and statesmanlike spirit. As an institution with a world-wide range and a New England headquarters, HORTICULTURE is pleased to give its endorsement and will endeavor to do its part in any movement which seeks to uplift this or any other section of our great country to the level of its highest possibilities. Horticulturally New England wields a wide influence; her institutions, her gardeners and florists, her gardens and parks, are second to none and Nature has here lavished shores, mountains, lakes and forests of sublime beauty, but the fame of all this can be vastly increased and New England's position in commercial horticulture greatly benefited by active intercity and interstate co-operation, with this specific purpose in view. Every horticultural society, every florists' club and every agricultural educational institution should be represented at the proposed conference.

Unfrilled orchid growing Commercial floriculture has made a well-defined stride within the past few years in its adoption of the orchid as its standard of highest quality and beauty in floral work. The movement was very slow to gain headway at first and it was only by the exercise of rare patience and tenacity that the pioneers in orchid introduction for commercial cut flower purposes made any advancement, but, at last, the barriers

The Hardy Rhododendron Question

Editor HORTICULTURE:

Replying to Mr. Brown's article in HORTICULTURE of May 9th, in which he takes issue with me, I will again say that my observations and experiences do not accord with his list of rhododendrons except in so far as mentioned in my former article. Now he may have had a different experience than I did with those kinds I list as tender. I will admit that my experience with these tenderer kinds has been confined mostly to Long Island, New York. In a general way if a plant is tender there it surely is so in Boston. Of course there may be exceptions.

As to what the term hardiness in the case of rhododendrons might reasonably be expected to mean my idea would be that in order to be termed hardy a rhododendron should come through an ordinary winter in a situation that is at least fairly well adapted to this class of plants with its buds and leaves as well as its wood practically uninjured, and this without any overhead protection of evergreen boughs, lath screens or the like. Under the foregoing conditions, and in some cases even with a winter overhead protection, I have seen on Long Island the varieties R. I. Halford, John Waterer, Mrs. John Clutton, Concessum, The Queen, and Lady Eleanor Cathcart, kill so badly that it would take them years to recover, while standing almost side by side with them was practically the entire list which I give under colors, and these latter came through in good shape.

Now if it can be shown that the varieties I have had my doubts about will in the vicinity of Boston, stand the above test I shall be glad to learn it, and would of course consider that they belonged in the "iron-clad" class for this neighborhood. Even if they fail of the above test but will come through an ordinary winter with a not unreasonably troublesome or expensive protection I should consider them hardy enough for use in many instances.

In New York city and vicinity it might not be unreasonable to demand, as a test for hardiness, that a rhododendron be able satisfactorily to withstand a winter without protection "in the middle of a ten-acre field," as I have seen rhododendrons there stand the winter without protection in some pretty exposed places, where I should hesitate about planting them.

Mr. Brown says that my list is "favored more by repute." In reply I would say that the list under colors given by me can be found fairly well represented in large sized plants in and around Boston, and in New York there are innumerable instances where this is so. Can as much be said of the list which I put down as tender? Also, most of the sorts listed (under colors) by me are carried by a number of nurserymen. Concerning the additional list of kinds which I give as doing well in the Arboretum I do not know just how widely these are distributed elsewhere, although, if I remember correctly, I have run across some of them outside of the Arboretum.

Mr. Brown states that he has proved part of his list by a five years' test. That would seem to be a pretty fair test. But is it? Would it be unreasonable to require a test of ten years, and to demand that at the end of that time the plants should still be shapely, not consisting of a few gawky shoots with perhaps a bunch of better growth at the base, as can sometimes be seen, and which in certain cases I have attributed to lack of hardiness, although this kind of development sometimes takes place, through abuse, in the case of hardy varieties.

Concerning what Mr. Brown has to say about the cir-

ulation of HORTICULTURE and my making a list for "Boston and vicinity," it seems to me that his point is not well taken. I do know, which Mr. Brown seems to think I do not, that the circulation of HORTICULTURE is not restricted to Boston and vicinity. I dare say its circulation takes in all the remote corners of the earth. This fact it seems to me is one of the many obvious reasons why in writing about the hardiness of rhododendrons it is best, or rather necessary, to mention localities, and to state what kinds will do in such and such localities, otherwise a mere list of rhododendrons, including all those kinds which are hardy somewhere, some here and some there, where HORTICULTURE circulates would quite likely include the whole existing catalogue of rhododendrons, and such a catalogue would be of no use whatever in this question of hardiness. Also, on the same principle of the ubiquitousness of HORTICULTURE any list of hardy rhododendrons would be useless in many places reached by this journal, simply because rhododendrons would not do there at all.

What I have just said in the foregoing sentences seems to me the logical conclusions of Mr. Brown's statement in the paragraph devoted to the "principal object" of his article. Admittedly many rhododendrons are hardy in localities in England which are not hardy in certain localities in New England. In Mr. Brown's article in the April 11th number there occurs this sentence, "There are a great many people who believe that the best of the English hybrids cannot be grown in the New England States, but one has only to consult any up-to-date catalogue of varieties to be astonished at the large number of sorts that have proved available for planting in New England." Here is no mention of locality except the very wide term "New England States." In his statement does Mr. Brown mean to include all of New England? Would he say, for instance, that his list of rhododendrons would survive under the winter treatment mentioned by him, say in Aroostook County, Maine? I have gone into this explanation in detail in an attempt to make clear what I had thought was obvious, viz.: why my list was intended for Boston and vicinity. Of course the fact that I am now living in Boston is an added reason for the selection of this particular locality.

I take it that Mr. Brown takes exception to the "imposing title, 'Iron-Clad Rhododendrons,'" appearing at the head of my article in the April 18th number. I did use the term, not a new one even in connection with rhododendrons, in the body of my article, but did not use it as a title for my manuscript or suggest that it appear as such when my article should be printed. The management of HORTICULTURE, I hope, will take no offense when I state that they, not I, are responsible for the use of this term as a title of my article.

I might state that the chief object of my criticism of Mr. Brown's previous article (as is also that of this article) was that I hoped by means of placing before the readers of HORTICULTURE the results of my own observation and experience to elicit the results of the experience and observations of others, thus perhaps leading to an interesting discussion and to the dissemination of valuable knowledge. I was quite aware that most of us, myself included, have quite a lot to learn regarding rhododendrons, not only as regards hardiness, but in other ways.

Samuel J. Kocher

NEWS OF THE CLUBS AND SOCIETIES.

CONNECTICUT HORTICULTURAL SOCIETY.

The regular meeting of this society was held in County Building, May 22, President Huss in the chair. It was "Pansy night" and the display was by far the best ever offered in this locality. The attendance was so large as to tax the capacity of the hall until there was barely standing room. P. Zuger, H. A. Pinney and Carl Peterson were appointed judges and made awards as follows: T. B. Brown, for culture of pansies, diploma; John Gerard and O. F. Gritzmach, for collection of pansies, certificate of merit each. J. F. Huss, A. Reynolds and E. F. McDermott received a hearty vote of thanks for their exhibits.

The feature of the evening was a paper read by John Gerard on "The History and Culture of the Pansy," giving the history and origin of the various families and describing most entertainingly the improvement of this popular spring flower. Mr. Gerard has established an enviable reputation as a pansy specialist and in the course of his remarks gave many cultural hints which were highly appreciated by the members.

The show was not confined entirely to pansies and a magnificent collection of gloxinias was tabled by J. Chambers, gardener to Rev. F. Goodwin. This fine exhibit gave ample evidence of cultural skill and Mr. Chambers was awarded a certificate of merit. P. Zuger represented the Park Department with a display of *Silene pendula* which is being used most effectively for spring bedding in the various parks.

A. CUMMING, JR., Sec'y.

MORRIS COUNTY GARDENERS' AND FLORISTS' SOCIETY.

The monthly meeting, May 13th, of this society was devoted to Flowering Shrubs. Three large groups of flowers in vases artistically arranged graced the hall. A. Herrington, Wm. Duckham, and D. Reagan were the principal exhibitors. Honorable mention and vote of thanks was awarded to each. From 40 to 60 varieties were in each group.

F. & F. Nurseries had azaleas in pots to help out, and John Downing, gardener to Dr. D. H. McAlpin, had plants of *Begonia Lorraine* which after five months' continuous blooming, were still fine. Arthur Herrington's essay on Flowering Shrubs was well received.

At next meeting, Frank Eskesen will read a paper on fern decoration, and all are invited to bring arranged fern dishes. There will also be a display of hardy herbaceous flowers. Schedule for the next flower show Oct. 29 and 30 is ready for the printer. Quite a few changes for the better are made, and all must hustle from now on to make it a success. E. REAGAN.

AMERICAN PEONY SOCIETY.

The sixth annual meeting of the American Peony Society will be held on June 18, 19, 1908, at the State College of Agriculture, Cornell University, Ithaca, N. Y.

A. H. FEWKES, Sec'y.

SOCIETY OF AMERICAN FLORISTS AND ORNAMENTAL HORTICULTURISTS.

Chas. H. Keitsch, superintendent of the trade exhibition to be held at Niagara Falls next August in connection with the annual convention, has sent out a circular calling attention to the excellent quarters secured by the Executive Board for the exhibition, comprising as it does the whole lower floor of one of the largest hotels—about 20,000 sq. ft. of floor space. Mr. Keitsch says that all indications now point to a very successful meeting from the exhibitors' point of view. The facilities for shipping to and receiving goods at Niagara Falls are of the best, and as the distance from the freight houses to the exhibition halls is very short, carting charges will not be excessive. The meetings of the S. A. F. will be held in one of the large rooms adjoining the exhibition halls, and all those who wish can secure lodging in the same building. Blank contracts, diagram of halls and all information as to rules and rates can be had by writing to Chas. H. Keitsch, 810 Main street, Buffalo, N. Y. The early applicant will fare best, of course.

NEW ORLEANS HORTICULTURAL SOCIETY.

Regular meeting of above society was held Thursday, p. m., May 21. The following business was transacted. A chrysanthemum and flower show will be given by the N. O. H. S. on Nov. 12, 13, 14 and 15, and over \$500 will be offered in prizes. No place has been secured for the exhibition as yet, but it is supposed that Lafayette Square or some other centrally located section of the city will be chosen. Prizes will be awarded for twenty-four different classes of chrysanthemums, fourteen classes of cut flowers, six of floral work with chrysanthemums, and four will be awarded to amateurs, in addition to which there will be premiums for plants or collections of plants. J. A. Newsham is chairman of the committee on arrangements with Chas. Eble ex-officio, and H. Papworth, J. Steckler, P. Abele, B. M. Wicher, M. M. de Lapouyade, C. W. Eichling, P. A. Chopin, R. Eichling, and Chas. A. Panter members.

The association indorsed the Crop Pest Commission. A communication on the black ant, the most destructive that gardeners have to deal with, from Prof. Newell, was read and very much appreciated.

Martin Behrman was elected an honorary member and Mr. and Mrs. Alost were thanked for their dinner some few weeks ago. The Steckler Seed Co., was also thanked for use of its wagons.

R. Eichling of U. J. Virgin exhibited coleuses, tuberous begonias, double petunias, lily of the valley. F. Calhounes exhibited some artemesia which has not been grown here to any extent.

CHAS. R. PANTER, Sec'y.

PENNSYLVANIA HORTICULTURAL SOCIETY.

At a meeting of the special committee held on the 26th inst. it was decided to hold the combined rose and peony exhibition on the afternoon and evening of Tuesday, June 2. Among the prizes offered are the following:

Peonies.

By Samuel T. Bodine, vase of six blooms, white, \$2.00, \$1.00; do. red, \$2.00, \$1.00; vase do. pink, \$2.00, \$1.00; vase of twelve blooms, mixed, \$3.00, \$2.00.

By Henry F. Michell Co., twelve varieties, named, six blooms of each, \$4.00, \$2.00.

By James W. Paul, Jr., twenty varieties, six blooms of each, \$10.00, \$5.00.

By George C. Watson, eight Japanese varieties, five blooms of each, \$10.00.

Peonies and Perennials.

By Henry A. Dreer, Inc.; peonies, collection of twelve varieties, three blooms of each, \$3.00, \$2.00; hardy perennials, display not less than twelve species (not varieties), \$3.00, \$2.00.

Outdoor Roses.

By Dr. Robert Huey, Hybrid Perpetuals, six varieties, six blooms of each, \$5.00, \$2.00, \$2.00; by Samuel T. Bodine, Hybrid Teas, three vases, three varieties, six blooms of each, \$3.00, \$2.00; Hybrid Tea, vase of twelve blooms of any variety, \$3.00, \$2.00; Hybrid Perpetual, vase of six blooms of any variety, \$2.00, \$1.00; by Henry F. Michell Co., best collection of outdoor grown flowers, \$3.00, \$2.00.

Flowers should be sent express prepaid in care David Rust, secretary, to arrive not later than 2 p. m., Tuesday, with a letter of entry by earliest possible mail in advance.

DETROIT FLORIST CLUB.

The Detroit Florist Club had a very large attendance at its regular meeting, principally caused by the announcement of the death of Wm. Scott in Buffalo, which was keenly felt by all. During its meeting the following resolutions were read by Secretary J. F. Sullivan and unanimously adopted:

Resolved, That in the death of Wm. Scott this club realizes that floriculture and horticulture has lost one of its best friends and most earnest advocates.

He was always foremost in all movements calculated to advance the floricultural and horticultural interests of the country and was a conspicuous contributor to the floricultural literature of his time; the great value of which is highly appreciated by thousands of persons engaged in the florist business.

His cheerful disposition and most enviable nature has endeared him to thousands of friends throughout the country by whom the news of his death will be received with the deepest sorrow; and.

Resolved, That this club send a floral offering to his funeral conveying its deepest sympathy with his widow and family, also a copy of these resolutions.

CLUB AND SOCIETY NOTES.

The date of the joint exhibition of the American Rose Society and the Horticultural Society of New York has been set for June 10 and 11.

Nassau County Horticultural Society (N. Y.) has selected June 10 as the date for their next exhibition in connection with the annual meeting.

The regular monthly meeting of Southampton Horticultural Society was held Thursday, May 21. It was decided to hold the summer exhibition on Wednesday and Thursday, August 19 and 20, instead of August 12 and 13 as originally agreed upon.

The Albany Florists' Club (N. Y.) met on May 7 with H. G. Eyres, Charles Sanders, foreman of the place, exhibited a scarlet seedling geranium with flowers of unusual size, and spoke of his work, which has covered nearly half a century, in a most interesting way.

The prize schedule for the June "Rose and Strawberry," the September "Fruit" and the November "Chrysanthemum" exhibitions of the Rhode Island Horticultural Society has been received. Copies may be had on application to C. W. Smith, Secretary, 27 Exchange St., Providence, R. I.

We have received regularly each week, copies of the bowling scores made by the ambitious members of the New York Florists' Club who are hoping to represent their club in the tournament next August at Niagara Falls. We have refrained from publishing them, however, out of compassion for the contestants whose scores, with one or two exceptions, are not exactly of the complexion to bring apprehension to the hearts of their rivals. We hope to get something more impressive in the near future.

Ladies' night was celebrated in joyous abandon by the members of the New York Florists' Club and their ladies on Wednesday Evening, May 27, at the club rooms on West Twenty-third street. About two hundred were present. Arrangements and catering were perfect in every detail and the affair was most enjoyable from start to finish. Bagpipes, violin and singing were all brought into requisition, the daughters of John Birnie taking a leading part in the entertainment and displaying musical talent of a high order.

At the last meeting of the Morris County (N. J.) Gardeners' and Florists' Society, Arthur Herrington delivered an interesting address on "Flowering Shrubs." It was an eloquent plea for a more general use of the vast fund of beauty afforded by this class of plants, the merits, attractiveness, permanence and cheapness of which are not sufficiently comprehended by the people.

Mr. Herrington gave as his selection of the twelve best spring-flowering shrubs, the following: Forsythia suspensa, Spiraea prunifolia flore pleno, Spiraea Van Houttei, Kerria Japonica, single type; Deutzia crenata, Pride of Rochester; Exochorda grandiflora, Pyrus (Cydonia) Japonica, Syringa (Lilac) any good colored variety; Syringa (Lilac) any good white variety; Viburnum plicatum Weigela amabilis or any other good variety, Philadelphus grandiflorus.

33RD ANNUAL CONVENTION AMERICAN ASSOCIATION OF NURSERYMEN.

At Plankinton House, Milwaukee, Wis.,
June 10-12, 1908.

For the thirty-third consecutive year the nurserymen of the United States will meet, June 10th, 11th and 12th, 1908. In looking after legislation; favoring good laws, opposing bad ones, and securing reasonable freight tariffs alone, the value of the work done by this Association cannot be over estimated. At a conservative figure the amount saved in freight rates during the past two years is \$100,000. Every nurseryman, be he grower, dealer or agent, shares in this benefit. About five hundred out of more than three thousand nurserymen do this work and pay the bills.

The income of the Association is derived from two sources—membership and advertising in the Badge Book.

Membership.

The annual fee is five dollars. It places your name on the roll of honor of the nursery industry. It's worth more than that to be in such company. It will help to secure a continuance of the advantages already gained. "Eternal vigilance" is the price of safety. Your representatives on the various committees work without compensation and at great personal sacrifice. Funds must be provided to pay actual expenses, to pay for testing unconstitutional legislation such as has been enacted in some states and will be followed in others if unchecked.

Send in your fee at once. Go to the convention if possible, but by all means if you cannot attend, have your name enrolled, lend the influence of your membership and contribute your financial support to the work being done in your behalf.

The Badge Book.

This barometer of the nursery industry will be issued as usual just previous to the convention.

It is, itself, worth more than the fee. It is probably the most prized nursery publication of the year. In it you will find a list of the best men in the business. If you want to know "who is who" in nursery lines the Badge Book is authority.

Railroad Rates.

The railroads after long consideration finally declined under date of April 29th, to grant the usual reduced fares on the certificate plan and suggested.

"That your people be referred to the summer tourist fares which will be in effect in Milwaukee at the time of your meeting. Full details of the Summer Tourist fares may be obtained upon application to the representatives of the several lines."

Arrangements have been made with the Chicago, Milwaukee and St. Paul Railway for special coaches and parlor cars on train leaving Chicago from Union Passenger Station, Canal and Adams St., at 11:30 A. M., June 9th, arriving at Milwaukee at 1:30 P. M. For those who wish to remain in Chicago for luncheon there will be special coaches and parlor cars on train leaving at 1:50 P. M., arriving at Milwaukee at 3:50 P. M.

Members should purchase tickets reading via Chicago, Milwaukee & St. Paul Railway from Chicago to Milwaukee and return.

Passengers holding through tickets and arriving Chicago on lines not entering Union Passenger Station will be transferred in rubber tired omnibuses free of charge.

Advise C. N. Souther, Gen. Agt., Pass'r Dept. C. M. St. P. Ry., 315 Marquette Bldg., what train you will leave Chicago on and also the number in your party.

The "Exhibits" will be in charge of the committee of which T. B. Meehan is chairman. This committee has secured two large rooms on the first floor of the Plankinton Hotel. In these rooms will be exhibited colored plates, lithographs, labels and all smaller exhibits. The heavier exhibits will be placed in a vacant store on the ground floor of the hotel. From present indications, there will be ample room for all exhibits. The committee desires entries for exhibits of everything that will interest nurserymen, including nursery stock tools of all descriptions and useful office appliances, records, etc. Applications for space must be made prior to the first of June, and same must be addressed to Thomas B. Meehan, Chairman of the Committee, Dreshertown, Pa.

Program.

WEDNESDAY, JUNE 10TH, 9:30 O'CLOCK
A. M.

Calling to order President J. W. Hill, Des Moines, Iowa.

Address of Welcome, Mayor D. S. Rose, Milwaukee, Wis.

Response, Geo. S. Josselyn, Fredonia, N. Y.

President's Annual Address, J. W. Hill, Des Moines, Iowa.

Announcement of arrangements for selection of State Vice-Presidents and for meeting of Vice-Presidents.

Report of Secretary; report of Treasurer.

Reports of Standing Committees. Transportation—E. H. Stannard Ottawa, Kas. Tariff—Irving Rouse, Rochester, N. Y. Legislation—Wm. Pitkin, Rochester, N. Y. National Inspection Law—Orlando Harrison, Berlin, Md. Publicity—J. M. Irvine, St. Joseph, Mo. Exhibits—Thomas B. Meehan, Dreshertown Pa. Editing Report—J. Horace McFarland, Harrisburg Pa. Mutual Fire Insurance—Peter Youngers, Geneva, Neb. Entomology—C. L. Watrous, Des Moines, Ia.

THURSDAY, JUNE 11TH, 9 O'CLOCK
A. M.

Roll Call of States. Naming Vice-Presidents. Report of Vice-Presidents. Election of Officers. Selection of Next Place of Meeting.

"How Can the Nurseryman Best Assist in the Civic Improvement Movement." J. Horace McFarland, Harrisburg, Pa.

"Is it Good Policy on the Part of the Nurseryman to Send Out Cheap Lists at the End of the Season?" J. M. Pitkin, Newark, N. Y.

"A Few Points on Improvements." Judge Eugene Stark, Louisiana, Mo.

(Subject not yet announced.) Prof. L. R. Taft, East Lansing, Mich.

"Semi-Tropical Thoughts for Nurserymen." H. B. Hume, Glen Saint Mary, Fla.

"The Great Southwest," Jno. S. Kerr, Sherman, Tex.

"Cost of Growing Stock." H. L. Bld, Benton Harbor, Mich.

"The Peony," H. D. Simpson, Vincennes, Ind.

"Elements of Success in the Nursery Business," J. B. Pilkington, Portland, Ore.

FRIDAY, JUNE 12TH, 9 O'CLOCK A. M.

"List of Desirable Fruits for My State and Are Recommended to the Plants" — C. M. Hobbs, Bridgeport, Ind.; J. Van Lindley, Pomona, N. C.; Geo. H. Whiting, Yankton, S. D.; C. J. Mahoy, Rochester, N. Y.; A. Willis, Ottawa, Kas.; E. W. Chittin, Winchester, Tenn.; W. F. Heikes,

Herts, M., Peter Youngers, Geney, Neb., F. A. Weber, Nursery, Mo.
Report of Committee on Final Resolutions.

The following list of questions has been prepared and will be taken up as the disposition of the program throughout the three days permits.

QUESTION BOX

Full and free discussion invited.
Question No. 1. Would it be advisable to have a law for the patenting or trademarking for various varieties of fruits?

Question No. 2. Does not the average nurseryman import nursery stock that can be grown at home? If so, why?

Question No. 3. Has any nurseryman succeeded in preventing apple crown gall and hairy root?

Question No. 4. Is there enough co-operation among nurserymen?

Question No. 5. Is the demand for ornamentals increasing?

Question No. 6. What class of nurserymen are able to manage a business and make a profit under present conditions?

Question No. 7. How should pecans be graded?

Question No. 8. Are the large orchardists still getting the benefit of wholesale prices?

Question No. 9. Are foreign houses careful enough in grading and sorting seedlings?

Question No. 10. The need of a better class of labor and how can we get it?

Question No. 11. Why should growing nursery stock be taxed as personal property any more than wheat, corn, etc.?

Question No. 12. Could not the apple orchard interests be improved by more stringent laws regarding the labelling of pure apple cider vinegar?

Question No. 13. Is the Kiefer pear responsible for the limited sale of pear trees at the present time?

Members are requested to avail themselves of gaining information by handing questions to the secretary at any time during the meeting.

In order to give members opportunity for ample social and business intercourse, the above program provides for one session daily. It is hoped that this arrangement will result in the attendance of every member at each of the three sessions.

Badges will be delivered to members by the secretary on registration at the convention.

Ladies in attendance will be supplied with badges on application to the secretary.

Announcement will be made during the first session of the time and place for meetings of the various Protective Associations, if information is placed in the hands of the secretary.

Prospectus and all other information may be had by addressing the Secretary of the Association, Geo. C. Seager, Rochester, N. Y.

A CORRECTION.

Editor HORTICULTURE:

Dear Sir,—In a report of Mr. Thos. White of some remarks made by me at a meeting of the New Bedford Horticultural Society in a recent issue of HORTICULTURE it is stated that I recommended the broad-petaled *Lilium canadense* for forcing. *L. candidum* was the variety referred to, and for outdoor culture I stated that it should be planted five inches deep. *L. canadense* and other varieties were better planted 9 to 12 inches deep and the first-named sort did well in rhododendron beds where it could have the advantage of some shade and a good mulching of leaves. No doubt the similarity of the names *candidum* and *canadense* was the cause of the trifling error.

W. N. CRAIG.

Longwater Gardens,
North Easton, Mass.

E. G. Hill left Richmond, Ind., on May 20, to attend the Paris international rose show, June 1 to 15, where he has been invited to officiate as a judge.

THE MOST USEFUL OF THE CATTLEYAS.

A paper read before the Buffalo Florists' Club by George E. McClure, Jr.

When the lay mind contemplates an orchid, a cattleya is what comes before his mental vision. In fact, we might say that the cattleya is the type of an orchid, not in a botanical sense, but as far as the public is concerned. Fully nine-tenths of the orchids sold in this country are cattleyas, and the genus cattleya will always hold first place as the most showy and useful of the family.

Among the 10,000 representatives of the natural order, Orchidaceae, there are few to surpass the cattleyas in beauty. The genus *Laelia* comes nearest to the cattleyas in point of beauty and usefulness; in fact, the uninitiated cannot discern between the two. The chief difference is an obscure botanical one. The cattleya has four tiny pollen masses, while the *laelia* has eight. This may be said to be the sole difference.

Two Classes of Cattleyas.

Cattleyas are divided into two fairly distinct classes, and although these classes are being bridged by incessant hybridization, yet in the majority of cases they are fairly distinct. The first is the monophyllous, or one-leaved class, which is restricted solely to what is known as the labiate, or large-lipped section, of which *C. labiata* is the type. Until quite recently this species was considered to be the sole representative of this group, and the other large-lipped forms as varieties and sub-varieties. Now all of these varieties are considered to be good species, which makes the labiate or, more properly speaking, monophyllous section quite formidable in point of numbers.

The other is the diphyllous, or two-leaved class, which includes a large number of species, which are chiefly characterized by smaller, more numerous and in some cases more fleshy flowers. The diphyllous cattleyas are not nearly as well known to the public as are the monophyllous or large-flowered forms, because they are not as showy and attractive, but some of the gems of the genus are to be found in the two-leaved class. The cattleya is an American orchid found growing from Mexico to South Brazil. Nearly all of the monophyllous cattleyas are natives of northern South America, while the diphyllous cattleyas are chiefly from South Brazil.

Culture of the Cattleya.

The idea generally prevails that cattleyas, and in fact all orchids, are difficult to cultivate. This idea is entirely without foundation. While it would be a mistake to say that the culture of a great many varieties in the same greenhouse would be easily accomplished, yet a little study and observation would enable any enthusiastic amateur to secure excellent results. Greenhouses specially built for cattleyas are not necessary; any light greenhouse, which is not too high, will prove suitable. The plants need not occupy valuable space on the benches, but may be suspended from the roofs

of greenhouses devoted to a mixed collection of plants, when a temperature of from 60 to 65 degrees Fahrenheit is maintained, and in this way will prove an acceptable by-product.

Location in the House.

The plants should never be more than four feet from the glass, and less than that is better. The only objection to the system of suspending cattleyas lies in the fact that they are often neglected and become too dry or too wet, at least when suspended high enough to be out of easy reach. Whenever bench room can be afforded it is well to raise the plants in this manner, as better oversight can be had over them. When the bench system is pursued, there should be a raised, or secondary bench placed upon the regular greenhouse bench. This bench should be made of wooden slats, from one and one-half to two inches wide, and from one-half to three-fourths inches thick. These slats should be made into frames four to six feet long, so as to be easily removed for the purpose of cleaning the lower bench. The upper, or slat bench should be raised about eight inches above the lower, on wooden or iron uprights. The uprights should stand in shallow pans of water to prevent snails or woodlice from reaching the plants. A layer of moss or fine gravel should be spread over the lower bench, which should be kept damp to insure a moist atmosphere, which is absolutely essential to the health of the plants.

Cattleyas cannot be successfully cultivated as window plants, no matter how bright the window may be, as the atmosphere in the living room is too dry. If the window is encased, after the fashion of a wardian case, and if sufficient light is afforded, a fair degree of success may be attained. This is a common practice in England, for the raising of cool orchids, and it would be worthy of a fair trial in this country for the culture of cattleyas, as our summers are hot enough to grow them without artificial heat. Any little greenhouse, heated by steam or hot water, could be utilized for cattleyas. A greenhouse heated by a flue would be of no value, because of the decimated atmosphere which is the inevitable result of this system of heating.

The Cattleya House.

If a greenhouse is to be built for the express purpose of raising cattleyas, it should be designed to be as low as possible, and if the greenhouse is narrow and built to accommodate two stages, the direction at which it is built is of no consequence, but if the house be high, with three stages and two walks, it should, if possible, run north and south, so that both sides have the benefit of equal light in the winter, which is very essential. The central bench in a three-bench house is usually broad and should be raised in the middle for economy of space. The raising of the plants in the centre stage would shade one-half of the plants in the winter, if the house ran east and west.

About Shading.

The matter of shading is an important one. With a small collection, in a small greenhouse, lath frames could

Orchids Orchids

Our Importations Will Arrive in One Weeks' Time. Prices on cases from \$45.00 to \$50.00 each of 500 strong bulbs or 45 to 50 plants. In order to help our customers we give **Special Sale for Fifteen Days.**

Established Plants, **C. Trianae**, from 7 to 10 bulbs with no less than two new growths, \$1.00 each, 10 to 15 at \$1.50 each. **C. Gaskelliana**, 15 to 25 at \$2.00.

ORDONEZ BROS., - Madison, N. J.

be made about the size of hot-bed sash, or just large enough to reach from the ridge of the house to the eaves. The rough laths of the plasterers could be used, if strict economy is desired; otherwise, planed lumber would be more desirable, as it could be painted and be more sightly and durable. The laths should be spaced according to their width; there should be as much light as shadow. Laths wider than one and one-half inch should not be used. The frames should be merely laid on the glass but not fixed to the house, as they should be removed in the evening and on all dull days. During the early spring when such a shade would be too heavy, a temporary shade may be secured by spraying the glass with a lime wash to which a little salt has been added. This shading can be easily removed with a hose when the lath shading is to be used. No shade should be used in the full winter months. When cattleyas are extensively raised, the best shading is obtained by the use of large wooden shades fixed to the roof and made to work after the fashion of the Venetian blind, from the ridge of the house to the eaves. The slats in this should not meet. When closed there should be a space one-quarter of the width of the slat between each slat. The slats should be not more than two inches wide. Each slat should be attached to a wooden rod, which can be manipulated from the ground. This rod can be so regulated as to admit any degree of light required. In dull weather, the only light obstruction is the width of the slat, about one-quarter of an inch. This is a labor saving device and is far ahead of any shade which cannot be controlled, such as paint or whitewash. The Venetian blind can be made to order at any planing mill at moderate cost and, if properly cared for, painted and stored each winter, will last many years. This shade is also an insurance against hail.

Culture.

The failure of which so often attends the raising of cattleyas is nearly always due to ignorance of the conditions under which the plants grow in a state of nature. Every one knows that there is a wet and dry season in the tropics and many believe that the dry season is more rigorous than it really is. Although the rains cease, the condensing of the moisture in the humid atmosphere of the tropics results in a heavy dew which sustains

plant life during the resting season. This condition is quite different from that of a green house in the winter, where excessive firing dries up the atmospheric moisture and causes the pseudo-bulbs to shrivel and the plant to lose its vitality. The pseudo-bulbs should never be allowed to shrivel. Water should be given occasionally during the resting season and the plants should be syringed lightly on all bright days. The resting season of the cattleya begins after the flowering period, or after the growth is matured, at which time the temperature should be kept several degrees lower if possible. Retard the growth of the plants as much as possible and when the new growth appears at the base of the pseudo-bulbs, begin to water well and increase the temperature. As the new growths increase in length water should be given in increasing quantity but it is well to bear in mind that ten times as much water should be sprinkled over the benches and walks and under the stages, to create a moist atmosphere, as is given to the plants directly. Abundance of fresh air should be given but the plants should never be subjected to draughts.

(To be Continued)

NOTE—Potting fertilizers, enemies and a list of the best sorts for commercial culture will appear in the continuation of this paper in another issue.

COVER ILLUSTRATION.

Our cover illustration shows a characteristic view in Boston's park system, in which the preservation of sylvan beauty is made a chief feature and well explains the fame which this great system has attained as compared with public reservations of a more artificial character. The use of bridle paths, of which there are about eleven miles in the Boston parks, is rapidly increasing ever year, especially in the spring and fall. Sometimes they run parallel to the driveways and again they sweep through woodlands. The trail shown in the picture is the connecting link between the Arnold Arboretum and the Stony Brook Reservation in the Metropolitan Park System.

Begonia Gloire de Lorraine

Strong 2 1/2 in. pot plants, leaf cuttings, \$15 per 100, \$140 per 1000. Early June delivery or NOW if wanted.

S. S. SKIDELSKY, 1741 No. 18th St. PHILADELPHIA

ORCHIDS

Largest Importers, Exporters, Growers and Hybridists in the World

Sander, St. Albans, England and 235 Broadway, Room 1 NEW YORK CITY

IMPORTED ORCHIDS

Arrived In Superb Condition

Vanda coerulea, Cattleya Trianae, Cattleya gigas Sanderiana, Cattleya Schroederiae, Oncidium varicosum.

JULIUS ROEHRS CO., Rutherford, N. J.

ORCHIDS for Spring Delivery

NEW IMPORTATIONS

Cattleyas, Laelias, Oncidiums, etc.

WRITE FOR PRICES

Now is the time to Pot Orchids. Best Quality of Peat, Moss and Baskets on hand.

JOSEPH A. MANDA, 191 Valley Road, WEST ORANGE, N. J.

ORCHIDS

arrived in superb condition

Cattleya Trianae, C. labiata, C. Mossiae, Oncidium Varicosum, Vanda Coerulea, Dendrobium Formosum and D. Dalhousieanum.

LAGER & HURRELL, Summit, N. J.

ORCHIDS

Arrived in fine condition. C. Mossiae, C. Percivaliana, C. Trianae, C. labiata, C. gigas Sanderiana, C. Harrisonia, C. Schroederiae, C. citrina Jlen, Formosum giganteum, D. Wardianum, D. Findleyianum, Oncidium Varicosum Rogersii, O. Tigrinum, O. Ornithobrychium, Laelia anceps. To arrive shortly, Vanda Coerulea, Cattleya Gaspelliana, C. Mendellii, Phalaenopsis Amabilis, P. Schilleriana.

CARRILLO & BALOWIN, Secaucus, N. J.

NEPHROLEPIS SCOTTII

in the following sizes, extra good value

25c., 50c., 75c., and \$1

Grand Specimen Plants at \$3, \$4, \$5, \$6.

JOHN SCOTT

Rutland Road and E. 45th St.

Tel. 2890 Bedford BROOKLYN, N. Y.

NEP. WHITMANI

2 1/4 in., \$5.00 per 100

NEP. WHITMANI

3 1/2 in., \$25.00 per 100

BOSTON FERNS

2 1/4 in., \$3.00 per 100

H. H. BARROWS & SON Whitman, Mass.

In ordering goods please add "I saw it in HORTICULTURE."

A SIXTY MILLION FLOWER SPIKE.

I went up to see Joseph Heacock the other day to get some palm growing hints from that expert. I got the usual also a bit or two about the palm family bordering on the wonderful. Here we think mostly of the palm as a lovely foliage plant and know little as to its full development in flower and fruit in its native soil. What would you say to a flower spike thirty or forty feet high, and estimated to contain sixty million blossoms? This, I am told, is well authenticated in the case of the Talipot Palm (*Corypha umbraculifera*). Can you imagine sixty millions of individual blossoms? I cannot. I can only hold up my hands like Dominic Sampson and say: "Prodigious!" I am also assured that although some of the seeds of palms are as small as a pea, others, like *Lodoicea sechellanum*, often weigh as much as forty pounds each. The average American seedsman would not have much trouble in getting 98 per cent purity in a cargo of *Lodoicea*. Of course these wonders of the palm world, and many others well known to botanists, are never seen with us where the palm is used only when small and for decorative purposes. In this connection its popularity is increasing yearly and another distinctive feature is the larger production of home-grown stock in the United States. The American growers, conspicuous among whom may be mentioned Heacock and Dreer, have far less dependence now on the European experts, and grow from seeds just as well, if not better, than the old-established growers on the other side. The most popular varieties at present are *Kentia Belmoreana* and *Forsteriana* (*Howea* botanically), *Areca lutescens* (*Chrysalidocarpus*), *Cocos Weddelliana*, *Livistona Chiensis*, *Caryota urens*, *Phoenix rupicola* and *P. canariensis*, and *Scaevortia elegans*. Mr. Heacock confines himself mostly to the first four.

The kentias are by far the most popular and satisfactory commercial varieties. The seeds are imported from Lord Howe's Island by way of Australia.

SPRING BULB BEDDING AT THE AGRICULTURAL DEPARTMENT, WASHINGTON, D. C.

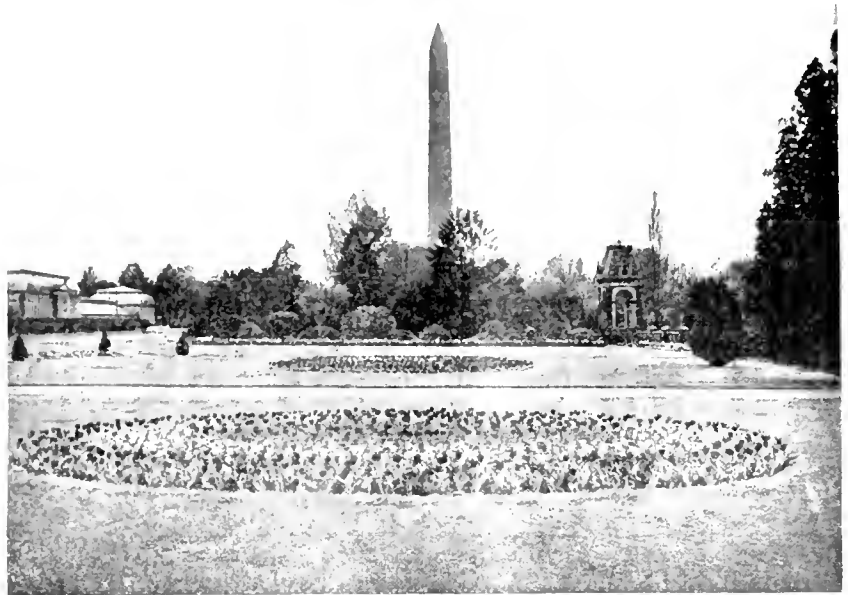

Circular bed of Tulips; centre, *Proserpine*; inner row, *Rose Gris de Lin*; outer row, *Belle Alliance*.

They are sown broadcast on their arrival, on a side bench in light soil covering to a depth of one inch. With liberal watering and a bottom heat of about 80 per cent most of the seeds will come up in two months, if the vitality is good. When the first leaf is developed the seedlings are planted in small pots and in about four months are usually large enough for a shift into 3 inch. From this stage on a night temperature of 60 degrees is found to be most satisfactory. The soil used is a light loam one-fourth peat and a sparing amount of fertilizer.

A similar process is followed with the seeds of *Areca lutescens* but they are allowed to remain in the seed bench until two or three leaves are formed. This variety is even more graceful and beautiful than the Kentias, but does not stand severe conditions as well. In the south the demand for it is far

better than in the north, the mild climate there being much in its favor.

The seeds of *Cocos Weddelliana* come from Brazil. These are about 1-2 an inch in diameter, and are usually sown on benches, but Mr. Heacock prefers to plant one seed to a pot as it obviates shifting, and is safer—as a critical time in *cocos* culture is the first shift. As the *cocos* is used when very small for fern dishes and other table decorations, millions of them are consumed every year. The present is the best time for shifting most palms so as to get the advantage of the summer growth—root action being dormant from November to April—and growers are now busy re-potting.

Mr. Heacock is building one new Lord & Burnham house, 20x67, and is throwing 15 detached houses into one connected range. Two of the large long-and-short-span houses will be altered into even-span, taking in the small side houses and making a fine range 280x90. A house will be devoted to the new bright pink seedling carnation (No. 100) the coming season. The other chief item grown here is American Beauty roses; also Richmonds and Killarneys in smaller quantities and cypripediums and cattleyas. As an example of the life of an ordinary greenhouse, Mr. Heacock pointed to one rose house built twenty years ago and good for quite a number of years yet. Two new sets of posts in that time; first chestnut, but they soon rotted, then locust and they soon went also. The story was told here of the old florist who swore by locust and claimed that it would last for ever, and of the endorsement of the dutiful son, "Yes, sir, that's a fact; and we can prove it, for the posts have been renewed twice in the past ten years." Now it's cedar posts, and they are as good as new, and the best material so far tried.

In Mr. Heacock's practice a chief secret of success is abundance of water above and below. Insecticides are almost unknown here.

GEORGE C. WATSON.

SPRING BULB BEDDING AT THE AGRICULTURAL DEPARTMENT, WASHINGTON, D. C.



Hyacinth border; King of the Blues, La Candeur, Charles Dickens.

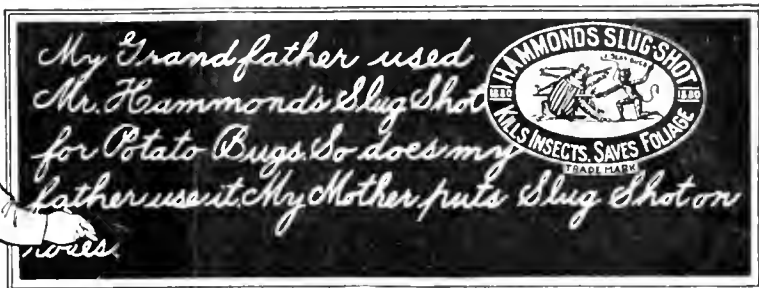

"SLUG SHOT"

Used from Ocean to Ocean

A light, composite, fine powder, easily distributed either by duster, bellows, or in water by spraying. Thoroughly reliable in killing Currant Worms, Potato Bugs, Cabbage Worms, Lice, Slugs, Sow Bugs, etc., and it is also strongly impregnated with fungicides. Put up in Popular Packages at Popular Prices. Sold by Seed Dealers and Merchants.

HAMMOND'S SLUG SHOT WORKS, FISHKILL-ON-HUDSON, N. Y.

For BUGS and BLIGHTS

HAMMOND'S

"SOLUTION OF COPPER"

"FRENCH BORDEAUX MIXTURE"

"GRAPE DUST FOR MILDEW"

"CATTLE COMFORT" FOR MILK COWS

Send for Pamphlets worth having.

Sold by Seed Dealers.

HYDROCYANIC GAS FOR WHITE FLY.

Editor of HORTICULTURE:—

My greenhouse is very badly infested with white fly and I would like to get rid of them before bedding out in the garden.

Can you through the medium of your reliable paper give me the formula for and instructions in the use of hydrocyanic gas for the extermination of this pest?

Canada.

W. T.

In answer to the above query we copy the following directions from Bulletin No. 123 of the Massachusetts Agricultural Experiment Station:

HYDROCYANIC ACID.

For Nursery Stock.

Potassic cyanid (98 or 99 per cent.). Sulfuric acid (1.83 sp. gr. commercial).

Water.

Multiply the number of cubic feet to be fumigated, by .2 or .25, giving the number of grams of cyanid needed for the house or box; divide the answer by 28.35, giving the weight of the cyanid in ounces. Take twice as many fluid ounces of acid and four times as many fluid ounces of water as was taken in ounces by weight of the cyanid. Mix the water and acid in an earthen or granite-ware jar, then by loose bag and string drop in the cyanid after tightly closing the place to be fumigated. Leave close 40 minutes, then open from the outside and air for at least ten minutes before entering.

White Fly in Greenhouse.

Fumigate as for Nursery Stock above, No. 25, except that instead of using .2 or .25 gram of cyanid per cubic foot, use .007 to .01 gram according to how tight the house is. Use the corresponding proportions of sulfuric acid and water, fumigate at night for three hours, and then ventilate. Repeat the fumigation two weeks later and a third time two weeks later. This treatment must be used with caution, as tender plants may under exceptional conditions be somewhat injured.

GREENHOUSES BUILDING OR CONTEMPLATED.

Melrose, Calif.—J. Groves, carnation house.

Geneseo, N. Y.—Charles Clapper, addition.

Sistersville, W. Va.—E. Huston & Son, one house.

Philadelphia, Pa.—C. Eisele, range of plant houses.

Elmhurst, Calif.—Hutchings & James, one house.

Victoria, B. C.—Fairview Greenhouses, two houses.

Fairfield, Conn.—N. S. Goulding, carnation house, 20x55.

Coffeyville, Kan.—Forest Park Floral Co., range of houses.

Glen St. Mary, Fla.—G. L. Taber, packing house, 70x116.

The park commissioner of Trenton, N. J., will receive sealed proposals for erecting a greenhouse at Cadwallader Park until June 5, 1908. Full particulars can be obtained by addressing the Board of Park Commissioners at the Mansion House.

SPRING PLANT TRADE IN CHICAGO.

After an almost unprecedented spell of rainy weather, Chicago is suddenly subjected to midsummer heat. The effect on the wholesale plant market has been little less than marvelous. One of the largest of the Chicago growers says there has probably been more trade in bedding plants crowded into the past few days than ever before in so short a time. Notwithstanding the fact that the late Easter and the long and unusual dark and rainy spell has had a tendency to weaken and retard trade, if the hot weather continues we will have a record breaker in the sale of bedding plants for Memorial Day. There seems to be nothing new in bedding stock but the old standby in geraniums, verbenas, pansies, etc., are holding their own and finding ready purchasers. Immense as the stocks of some of the Chicago growers has been it was pretty well sold out several days before Decoration Day.

In last week's issue of HORTICULTURE, page 698, we located the A. E. Kunderd Gladiolus Gardens at Kendallville, Ind. We should have said Fort Wayne.

Massachusetts has recently appropriated \$34,000 for a range of greenhouses of modern type and attached instruction building for use of the floricultural department of the agricultural college at Amherst.

DON'T EXPERIMENT

USE

To-BAK-INE

and your stock will be free from insects, clean, and the blooms will not be discolored.

Send for full information of

W. W. RAWSON & CO.,
5 Union St., Boston.

STUMPP & WALTER CO.,
50 Barclay St., New York.

HENRY F. MICHELL & CO.,
1018 Market St., Philadelphia.

E. H. HUNT, Gen'l Agent,
76-78 Wabash Ave., Chicago.

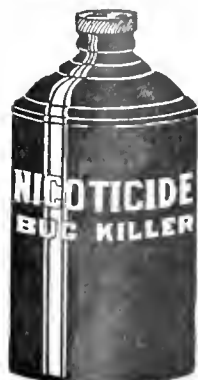

The Best Bug Killer and Bloom Saver

For PROOF Write to

P. R. Paethorpe Co.
OWENSBORO, KY.

Seed Trade

L. H. Fitch has purchased a large tract of land in the town of Columbus, O.

Henry Nungesser of New York City returned last week from his 15th voyage to Europe.

The doctor, Outerbridge of Sunningdale, Bermuda, has been a visitor in Boston the past week.

F. W. Wood & Sons, Richmond, Va., have purchased a large tract of land near Milton for a seed farm.

Hogg & Lytle, formerly at Port Hope, Ont., are now located at 413 Board of Trade Building, Toronto.

The Lohman Seed Co., Detroit, Mich., is now fully established in its new and convenient quarters. They report a largely increased counter trade.

L. P. Archias, of Archias Seed Store Corporation, and J. C. Archias with Batteldes Seed Co., Denver, will leave New York for a European trip on S. S. Aurifila, June 4.

John Fottler of Boston is home from the sanatorium after a dangerous illness. He is still very feeble but a full recovery is looked for within a few weeks.

F. W. Brungelhof, of J. M. Thoburn & Co., and Captain Burnett Landrath of the D. Landrath Seed Co., Bristol, Pa., are making a trip among the seed growers of the Pacific coast.

AMERICAN SEED TRADE ASSOCIATION.

The topics that will be discussed at the Convention at Detroit this year are of interest to all seedsmen.

There will be interesting reports from committees in regard to seed legislation both State and National.

Thousands of people annually pass through Detroit that do not know they have the right to a ten days' stop-over on their tickets without extra charge. This applies to all tickets to or from any point in the U. S. or Canada, provided same is within the final limit of said ticket. Passengers desiring this privilege will make application for same to conductor or train auditor, and latter will endorse coupon "Off at Detroit," date and sign same, and advise passengers that immediately upon arrival at Detroit the ticket must be deposited with the agent at the depot arrived at. The agent will furnish a receipt for ticket.

There will probably be very few rates offered to the Convention of the National Education Association at Cleveland, so any members wishing to attend the latter they can use the

upwards, without meals. Other hotels are near and eating houses numerous.

C. E. KENDEL, Sec'y.
Cleveland, O.

The program for the 26th annual convention has been issued in a neat little pocket pamphlet form. The meetings will be held on June 23, 24, 25, 1908, at the Hotel Pontchartrain Detroit, Mich.

NEWS NOTES.

Reginald Pratt and Frank Foss have started in the florist and nursery business at Wayne, Pa.

Denison, Tex., May 22.—The premium list for Denison's annual flower show and the catalogue will be ready for distribution soon. The show will be held under the auspices of the Denison Civic Improvement League, the catalogue will be a very neat booklet and the premium list will be large and attractive to amateur and professional florists. The ladies of the League are working enthusiastically in expectation of an even greater show than the splendid events of last year and the year before.

Robert S. and J. Frank Edgar, sons of the late W. W. Edgar, have formed a partnership, dated June 1, 1908, under the firm name of Edgar Brothers, and have acquired from the W. W. Edgar Company that portion of the property known as "The Farm," at Waverley, Mass. There are two fine new greenhouses comprising about 15,000 ft. of glass, and twenty-five acres of land, which will be devoted to the wholesale growing business. These two young men have had a thorough training under a strict father and are well equipped to make a success of their venture. Frank, who will attend to the selling department, has had a good experience in the Boston market. Robert has served as foreman in his father's business for two years. He had also two years' experience in plant growing in England and Belgium.

LIST OF PATENTS.

- 885,759 Plow, Truman J. Johnson, Williams, Iowa.
- 885,827 Weed Destroyer, Charles P. Anderson, Brown Valley, Minn.
- 885,998 Manure-Spreader, Eugene Ruswell, Waterloo, Iowa.
- 885,983 Cultivator, William A. Dewberry, Center Hill, Ark.
- 886,000 Seed Separator, Frank G. Lyman, Wapakoneta, Ohio; assignor of one-half to John E. Gunther, Wapakoneta, Ohio.
- 886,155 Land Marker, Robert G. Riels, Murphy, Ga.
- 886,167 Mower, Oscar C. Weikel and Eric R. Weikel, Ronceverte, W. Va.
- 886,190 Cultivator, Jacob F. Deal, Tipton, Ia.
- 886,200 Cultivator, Thomas Grasmann, Columbia, Ill.
- 886,217 Plow, Distributor, Ephraim B. Haeblynn, William C. Willitt and Dennis F. Hoop, Newborn, N. C.
- 887,041 Plow, Loren F. Wheelless, Warren, Ark.

AUCTION SALES
TUESDAY & FRIDAYS
AT NOON.

CARPET BEDDING, PLANTS, BAY TREES, PALMS, AND BULBS

W. ELLIOTT & SONS
42 Vesey Near Church
NEW YORK, N. Y.

PUBLICATIONS RECEIVED.

Annual report of Philip C. Scanlan, Park Commissioner of the City of St. Louis. It appears from the details of this report that the administration of the various sections and departments is in every instance well within the limits of the several appropriations made for their maintenance. Economical and careful management is conspicuously evident in the itemized financial reports. The book is illustrated with a number of half-tone plates and a set of panoramic views of the site of the World's Fair before, during and after that memorable event.

"The Romance of the Reaper" has been received from the publishers, Doubleday, Page & Co. This book, by Herbert N. Casson, tells in a most absorbing way the story of the growth of the great agricultural machinery manufacturing industry in America and vividly portrays the tremendous industrial revolution and the emancipation of the agriculturist, which have been brought about by the introduction of American labor-saving agricultural inventions. To the average reader this remarkable story of amazing progress made and forecast of still greater progress yet to come will prove a veritable "eye opener" and he will, indeed, see things in a new light and be quite ready to admit, with the gifted author, that "the harvester is the best barometer of civilization."

VEGETABLE PLANTS

- CABBAGE** Wakefield, L. I. Second Early, Early Flat Dutch, Early Summer, Wimingstadt, and other late var. at \$1.00 per 1000, \$8.50 per 10,000.
- BEEF** Eclipse, Crosby's, Egyptian, at 25c per 100, \$1.25 per 1000.
- LETTUCE** Boston Market, Tennis Ball, Pig Boston Grand Rapids, 20c per 100, \$1 per 1000
- GELERY** White Plume, G. S. Blanching at 20c per 100, \$1.00 per 1000.

Cash with Order.

R. Vincent, Jr. & Sons Co., White Marsh, Md.

Enormous Asparagus SEED OF SAME

Only a few pounds of this famous seed and will sell a bushel's worth of it. Seven stalks have been cut for one bushel this season. All of this seed is selected, and will give the best results. You can save three-fourths of the price of the plants if you will plant the seed. A pound of this seed will bring you thousands of fine plants. Plant it now and have lots of plants for this winter's forcing. **WARREN SHINN, WOODSTOWN, N.J.**

CATALOGUES RECEIVED.

Yokohama Nursery Co. Ltd., New York.—Catalogue of Japanese Nursery Stock and Seeds, "for the wholesale nursery trade only."

National Seed Company, Chicago, Ill.—Descriptive Catalogue of Garden and Farm Seeds, Plants, Shrubbery, etc. This, we understand, is a new firm and the catalogue is a very creditable one, with colored cover and freely illustrated.

INCORPORATED.

Gate City Seed Co., Keokuk, Ia.: A. M. Davidson, W. D. Burt, H. E. McCoy; capital, \$30,000.

Reports from District of Columbia indicate that the berry and small fruit crop about to ripen will be the largest in many years.

PRIMULA, FRINGED SINENSIS

This seed has been grown for us by a specialist in the culture of Primula, and he has produced plants of sturdy growth, large, thick flowers beautifully fringed and carried on erect stems well above the foliage; unexcelled in size, substance and beautiful colors.

Giant Perfection Strain, Finest Mixed, 1-64 oz., \$1.00
Pure White, Brilliant Pink, Blue, Chiswick Red, and Crimson, 1-64 oz., \$1.00.

H. E. FISKE SEED CO.
13 Faneuil Hall Sq., BOSTON, MASS.

C. C. MORSE & CO.

Address all communications to our permanent address
48 to 56 Jackson St., San Francisco, Cal.

**The Largest Seed Growers
in the United States**

**C A U L I F L O W E R S
C A B B A G E S**

HJALMAR HARTMANN & CO.,
12 Stormgade,
COPENHAGEN, DENMARK.

Burpee's Seeds

PHILADELPHIA

Blue List of Wholesale Prices mailed only to those who plant for profit

**Winter-flowering
SWEET PEA SEED**

All Colors

New crop ready in August next. Ask for list.

A. C. ZVOLANEK
ORIGINATOR BOUND BROOK, N. J.

XXX SEEDS

CHINESE PRIMROSE. Finest grown, varieties mixed; 500 seeds, \$1; half pkt., 50c.

CINERARIA. Finest large-flowering dwarf, mixed; 1000 seeds, 50c.

GIANT PANSY. Best large-flowering, mixed, critically selected; 5000 seeds, \$1; half pkt., 50c. Cash.
JOHN F. R. PP., SHIREHANSTOWN, PA.
The Home of Primroses.

BRECK'S SEEDS

For Farmer, Market Gardener and Florist
New Crop High Grade
Catalogues mailed free on application

Joseph Breck & Sons Corp.
47-54 NO. MARKET ST., BOSTON, MASS.

Reliable Flower Seeds FOR Sowing Now

Asparagus Plumosus Nanus

We offer fine, plump, new crop, lath house grown seed of high germination at the following special low prices:

100 seeds.....\$.40 | 1000 seeds.....\$3.00
500 "\$ 1.75 | 5000 "\$13.75
10,000 seeds.....\$25.00

Primula Chinensis Fimbriata

Mitchell's Prize Mixture. — Contains only

the finest sorts, selected from the best strains. Half trade pkt. 6c. — \$1.00 per trade pkt.; per 1-16 oz. \$2.00.

Primula Obconica Grandiflora

Kermesino, Red.....Trade Pkt. 1.10
Rosea, Pink....." " 1.50
Alba, White....." " .30
Hybrida, Mixed....." " .30

Henry F. Michell Co., 1018 MARKET STREET Philadelphia, Pa.

COLD STORAGE LILIES

COLD STORAGE LILIES, means that you can have Lilies all the year round. What are more useful, or give more character to the funeral piece than the Lily.

We have, and can deliver at any time cold storage Lilies—and can refer you to hundreds that are growing them, why not you?

LILIUM LONGIFLORUM GIGANTEUM is the only longiflorum that gives satisfaction from cold storage—we offer them as follows:—**LILIUM LONGIFLORUM GIGANTEUM** (repacked 6 to 8 inch bulbs 400 in a case, \$8.50 per 100, \$75.00 per 1000, case of 400 for \$30.00. 7 to 9 inch bulbs, 300 in a case \$9.00 per 100, \$85.00 per 1000, \$25.50 per case of 300. 9 to 10 inch bulbs, 200 in a case, \$14.00 per 100, \$130.00 per 1000, \$26.00 per case of 200.

ARTHUR T. BODDINGTON, Seedsman, 342 WEST 14TH STREET, NEW YORK CITY

ASTER GROWERS ATTENTION:—

Our Seed is All Sold. If you failed to get some it is your loss. However:— Get a Competition Card Now, Enter your name as an Aster Grower of America and win part of our \$250.00 offered in prizes. Entry free. All information gladly given. No cost to you except to prepay the express charges on flowers sent in competition.

Altimo Culture Co., Canfield, Ohio.



Seeds of ASPARAGUS PLUMOSUS NANUS, \$2.00 per 1000.

Seeds of ASPARAGUS PLUMOSUS ROBUSTUS, \$2.00 per 1000.

COLD STORAGE LILY OF THE VALLEY PIPS

JAPAN LILIES, JAPAN IRIS

For prices, state quantities required.

J. M. THORBURN & CO.
33 Barclay St., through to 38 Park Place
NEW YORK

Best Quality Fall Bulbs

It is to your advantage to place your order early. Send us a list of your wants and we will quote you rock-bottom prices. Copy of our Florists' Bulb Catalogue will be sent upon request. Catalogues now ready.

VICK'S SUPERB PANSY SEED

All the best varieties in separate colors

VICK'S SUPERB MIXTURE

the best strain from all the leading named sorts

1-8 oz. 75c. 1-4 oz. \$1.50 Ounce \$5.00

JAMES VICK'S SONS, Rochester, N. Y.

**RELIABLE SEEDS
SOW NOW**

Ageratum Mexicanum Blue Star—
Tr. Pkt. 25c. 6 Tr. Pkt., \$1.25.

Lobelia Erius Pendiculata Hamburgia
Tr. Pkt. 25c. 6 Tr. Pkt., \$1.50.

Primula Obconica Grandiflora—

New Hybrids: Blood-red, Blue, Carmine, Pink, Purple, Violet, Pure-white, Compacta, Gigantea, Fringed Mixed Hybrids, each separate, Tr. Pkt. 50c. 6 Tr. Pkts., \$2.50.

My Catalogue will guide you through Reliable Seeds. Ask for Same.

O. V. ZANCEN
SEEDSMAN, HOBOKEN, N. J.

JUST ARRIVED

LARGE SHIPMENT OF
High-Grade SCOTCH SOOT.

We have the **Stott Double Nozzle**
THOMAS J. GREY CO.

32 & 33 So. Market St., BOSTON

BRIDGEMAN'S SEED WAREHOUSE

RICKARDS BROS.

Props.

37 East 19th St., - NEW YORK CITY

BRASLAN SEED GROWERS CO.

GROWERS FOR THE

WHOLESALE TRADE ONLY

SAN JOSE, - CALIFORNIA

Like the Bee so is Godfrey Aschmann, the Philadelphia Hustler, Never Idle

IF YOU ARE IN MARKET FOR BEDDING PLANTS, GRAB THIS BARCAIN NOW OFFERED.

- Geraniums, S. A. Nutt, John Doyle and assorted varieties, 4 in. pots, per 100, \$7.00.
- Agerat in, dwarf blue, 4 in., per 100, \$7.00.
- Begonia Vernon, the best dark red varieties, and the fine improved prior to the ever-blooming variety of Europe, 4-in., per 100, \$7.00; 3-in., per 100, \$7.00.
- Scarlet Sage, the true Bonfire or Clara Belman, 4 in., \$7.00.
- Heliotrope, 4-in., per 100, \$7.00.
- Fuchsias, best varieties, 4 in., \$7.00 to \$8.50 per 100.
- Ivy, English or Hardy, staked up, 3 feet high, 4 in., per 100, \$12.00.
- Viburnum Variegata, 4 in., per 100, \$10.00; 2 1/2 in., \$4.00.
- Cobaea Scandens, 4 in., staked up, per 100, \$8.50.
- Geraniums, Mme. Salleron, for borders, strong plants, per 100, \$4.00.
- Phlox Drummondii Grandiflora, 3/4 to 3 in., per 100, \$1.00.
- Lobelia, Dwarf and Trailing, 2 1/2 in., per 100, \$1.00.
- Tradescantia, 2 best varieties, 2 1/2 in., per 100, \$1.00.
- Ground Ivy, 2 1/2 in., per 100, \$1.00.
- Verbenas, best strain, all colors, 2 1/2 in., per 100, \$1.00.
- Sweet Alyssum, Little Gem or Carpet of Snow, 2 1/2 in., per 100, \$1.00.
- Summer Chrysanthemums, 3-in., best kinds, per 100, \$1.00.
- Nasturtiums, best dwarf, all colors, 3-in., per 100, \$1.00.
- Centauria Gymnocarpa, Dusty Miller, 2 1/2 in., per 100, \$1.00.
- Torenia Fournieri, 2 1/2 in., per 100, \$3.00.
- Kenilworth Ivy, 2 1/2 in., per 100, \$3.00.
- Petunias, California Giant, 3 in., per 100, \$4.00. Inimitable or dwarf, 2 1/2 to 3 in., per 100, \$3.00.
- Marigolds or Tagetes, Eldorado, Gold Ring, 3 in., per 100, \$1.00.
- Best French Cannas, about 12 superior colors, by name, very strong plants, 4-in., per 100, \$7.00 to \$8.00.
- Clematis Jackmanni, late fall importation, 3 ft. high, newly staked up, 35 to 40c.
- Araucaria Excelsa Glauca, 6 to 7-in. pots, last spring (1907) importation, 5 tiers, 25 to 40 inches high, same in width, 6 year old, suitable for lawns and parks, \$1.75, \$2.00, \$2.50, \$3.00, \$4.00 each.
- Imported two weeks ago 500 Araucaria Excelsa, 3 tiers, 6-8-10-in. high, 40c; 10-12-14-in., 50c, 60c, 75c, \$1.00 each.
- Kentia Belmoreana, 3 1/2 in., 20-25 inches high, 5c, 60c, 4 in., 35c. Forsteriana, large plants, \$2.50 each.
- Cosmos, separate colors, 3-10, 3 plants in a pot, per 100, \$3.00.

Cash with order, please. All goods must travel at purchaser's risk

Godfrey Aschmann

Importer, Wholesale Grower and Shipper of Pot Plants
1012 West Ontario St. Philadelphia, Pa.

RUBBERS 4 inch pots, \$20.00 per 100, \$2.50 per dozen.

ARAUCARIAS Nice 4 inch stock, 40c. Larger 50c, 75c, \$1.00

BEDDING PLANTS Geraniums, 4 inch Single and Double Dryden, \$8.00 per 100. Other varieties at \$7.00 per 100. Salvia Zurich and Bonfire, Lobelia Kathleen Mallard and all other new and standard bedding stock in best quality at lowest market rates.

JOHN MCKENZIE

North Cambridge, Mass.

PALMS Home Grown.

ARECA LUTESCENS

	Each	Doz.
1 in. pot, 3 plants, 24 to 26 in. high	\$1.00	\$12.00
7-in. pot, 3 plants, 30 to 32 in. high	2.00	24.00

COCOS WEDDELIANA

2 1/2 in. pot, 8 to 11 in. high	1.00	
2 1/2 in. pot, 11 to 12 in. high	.75	

KENTIA FORSTERIANA

9-in. tub, 4 plants, 4 ft. high, heavy	6.00	
--	------	--

KENTIA BELMOREANA

	Each	Doz.
6-in. pot, 6 to 7 leaves, 22 to 24 in.	\$1.00	\$12.00
6-in. pot, 6 to 7 leaves, 24 to 26 in.	1.25	15.00
6-in. pot, 6 to 7 leaves, 26 to 28 in.	1.50	18.00
6-in. pot, 6 to 7 leaves, 30 to 36 in.	2.00	24.00
7-in. pot, 6 to 7 leaves, 32 to 34 in. heavy	2.50	30.00

JOSEPH HEACOCK COMPANY, Wyncote, Pa.

BAYSTATE

Now Booking Orders for Next January Delivery.

Rooted Cuttings, \$12.00 per 100, \$100.00 per 1000

ALBERT ROPER, Tewkesbury, Mass.

The big sensation of all the recent Carnation Shows. A noble flower, white with carmine markings.

AZALEAS

for fall delivery, the best that are grown, also PALMS for spring or fall delivery, furnished by Belgium; orders booked now.....

AUGUST ROLKER & SONS, 31 Barelay Street, or P. O. Box 752, New York

COLEUS

Verschaffeltii, Golden Queen, Fire Brand, Lord Palmerston, Queen Victoria, Beckwith's Gem. Prices of Rooted Cuttings by express, 60c. per 100; \$5 per 1000. Less than 250 of a variety will be charged at the 100 rate.

Golden Bedder, Hero, Plessey, Pearl of Orange, 75c. per 100; \$6 per 1000. Little 250 of a variety will be charged at the 100 rate.

Fancy Varieties. A very fine assortment of twelve kinds not listed above. 75c. per 100; \$6 per 1000. 250, 10 assortment, our selection, at the 100 rate.

MISCELLANEOUS PLANTS

AGERATUM, Stella Gurney, Princess Pauline. SALVIA Splendens, Bonfire. HELIOTROPE. Rooted cuttings, 75c. per 100; \$6 per 1000.

CARNATIONS

Rooted Cuttings

Winsor	100	\$6.00	1000	\$50.00
White Perfection	2.50		20.00	
Rose Pink Enchantress	3.50		30.00	
Enchantress	2.50		20.00	
Queen Louise	2.50		20.00	

From 2 1/2 inch pots, add \$1.00 per 100.

ASPARAGUS PLUMOSUS MANUS SEEDLINGS From flats, \$1.00 per 1000.

CHRYSANTHEMUMS

Standard varieties, ready for shipment. Rooted cuttings, \$2 per 100; \$15 per 1000. Send for list.

A. N. PIERSON, CROMWELL, CONN.

HYACINTHS, TULIPS, NARCISSI AND OTHER BULBS

ROMAN HYACINTHS and the true PAPER WHITE GRANDIFLORA

Ask for our Wholesale Trade List at Hillegom

K. VELTHUYS, Hillegom, Holland Rep. by FELIX BOGCH, 260 Clarendon St., Boston.

HIGH GRADE DUTCH BULBS

W. J. ELDERINC & SON

Overveen, Haarlem, Holland

Special Quotations on large quantities. Wholesale Only

New York Address HOTEL SEVILLE

FIRST CLASS STOCK

Geraniums, 8 varieties in bud and bloom, strong, bushy, spread-out plants, 3 1/2-4 in. \$4.50, 3 in. \$5.50 per 100, \$50.00 and \$30.00 per 1000. Not in bloom, \$3.50 and \$2.50 per 100. Coleus, 12 varieties, strong 2 in. \$1.50, 3 in. \$2.50 per 100, \$14.00 and \$20.00 per 1000. Begonia Vernon in bloom, strong 3 in. \$4.00, 4 in. \$5.00 per 100. Salvias, Petunias, Lobelias, Verbenas, in bloom, strong 3 in. \$2.50 per 100 each. Stock guaranteed.

WILLIAM S. HERZOG, Morris Plains, N. J.

CARNATIONS

F. DORNER & SONS CO.

La Fayette, Ind.

ROOTED

CARNATION CUTTINGS

Only the Best Varieties

CHICAGO CARNATION CO., JOLIET ILL.

400 3 1-2 inch

SALVIA SPLENDENS

Only \$4.00 per hundred

3 inch pots, \$3.00 per hundred

3 inch Lemon Verbena, \$7.00 per hundred COHANZIE CARNATION GREENHOUSES, New London, Conn.

JOHN E. HAINES

Bethlehem, Pa.

is the place to order rooted cuttings of the following varieties for 1908.

John E. Haines, red	} Per 100 Per 1000
Imperial variegated	
Pink Imperial, Pink	
Enchantress, Light Pink	
Place your orders early for Jan. delivery.	\$6.00 \$50.00

In writing to Advertisers kindly mention Horticulture

Anything of Value
to the profession

CAN BE SOLD

through advertising in

Horticulture

GERANIUMS
A Large Assortment of the Choicest Kinds.
From 3 1/2 in. pots, \$7.00 and \$8.00 per 100.

HYDRANGEAS
50c to \$5.00 each.

10,000 Tomato Plants
In fine condition. Write for Prices.

WM. W. EDGAR CO.,
Waverley, - - - - Mass.

GERANIUMS

A CORDIAL invitation is extended to all interested in Geraniums to visit us during May and June, to inspect our new stock houses containing over 60,000 plants, and especially to see our new show house; in it there are over 300 varieties in full bloom; a splendid opportunity to compare the newer introductions with the old standards, and to select stock for next season. We will make very liberal special prices on all orders booked during May and June for December delivery. We are at Cowenton on the B. & O. R. R., and at Chase on the Pennsy. We meet all trains.

DAHLIA ROOTS Whole field clumps, at \$5.00 per 100 and up; send for list of 75 varieties

HARDY CHRYSANTHEMUMS A splendid collection of the very best 75 varieties, Small Flowered or Button \$2.00 per 100. Large Flowered or Aster type \$3.00 per 100.

DAHLIA PLANTS From 2-in. pots, ready for immediate shipment at \$2.00 per 100 and up. We will send 1000 in 20 good varieties, our selection, for \$18.50.

PELARGONIUMS In good variety, 3-in pots, \$1.50 per dozen, \$6.00 per 100.

<table border="0"> <tr><td>Ageratum, Stella Gurney</td><td>Per 100</td><td>\$2 00</td></tr> <tr><td>Begonia, Vernon, White and Rose.....</td><td>2 00</td><td></td></tr> <tr><td>" Gracilis, White and Rose.....</td><td>2 00</td><td></td></tr> <tr><td>Coteus, Verschaffeltii, Golden Bedder and other kinds</td><td>2 00</td><td></td></tr> <tr><td>Fuchsias, Black Prince and Minnesota..</td><td>2 00</td><td></td></tr> <tr><td>Lieutenant Muritz, White and Rose Phenomenal</td><td>2 50</td><td></td></tr> <tr><td>Hardy English Ivy, Extra Strong.</td><td>\$15.00 per 1000</td><td></td></tr> <tr><td>Hardy Phlox,</td><td>2 00</td><td></td></tr> </table>	Ageratum, Stella Gurney	Per 100	\$2 00	Begonia, Vernon, White and Rose.....	2 00		" Gracilis, White and Rose.....	2 00		Coteus, Verschaffeltii, Golden Bedder and other kinds	2 00		Fuchsias, Black Prince and Minnesota..	2 00		Lieutenant Muritz, White and Rose Phenomenal	2 50		Hardy English Ivy, Extra Strong.	\$15.00 per 1000		Hardy Phlox,	2 00		<table border="0"> <tr><td>Hollyhocks, Strong 3 in. pot plants, dbl. white, pink, red and yellow.....</td><td>Per 100</td><td>3 00</td></tr> <tr><td>Ivy Leaved Geraniums, 6 good kinds, \$25 00 per 1000</td><td>3 00</td><td></td></tr> <tr><td>Lobelia, Crystal Palace Gem</td><td>2 00</td><td></td></tr> <tr><td>" Kathleen Mallard, 2 inch.....</td><td>3 00</td><td></td></tr> <tr><td>Lavender, 2 1/2 in. pots strong</td><td>3 00</td><td></td></tr> <tr><td>Swainsona, Alba</td><td>2 00</td><td></td></tr> <tr><td>Tradescantia, Dark Variegated.....</td><td>2 00</td><td></td></tr> <tr><td>Verbena, Red, White, Purple and Pink</td><td>2 00</td><td></td></tr> </table>	Hollyhocks, Strong 3 in. pot plants, dbl. white, pink, red and yellow.....	Per 100	3 00	Ivy Leaved Geraniums, 6 good kinds, \$25 00 per 1000	3 00		Lobelia, Crystal Palace Gem	2 00		" Kathleen Mallard, 2 inch.....	3 00		Lavender, 2 1/2 in. pots strong	3 00		Swainsona, Alba	2 00		Tradescantia, Dark Variegated.....	2 00		Verbena, Red, White, Purple and Pink	2 00	
Ageratum, Stella Gurney	Per 100	\$2 00																																															
Begonia, Vernon, White and Rose.....	2 00																																																
" Gracilis, White and Rose.....	2 00																																																
Coteus, Verschaffeltii, Golden Bedder and other kinds	2 00																																																
Fuchsias, Black Prince and Minnesota..	2 00																																																
Lieutenant Muritz, White and Rose Phenomenal	2 50																																																
Hardy English Ivy, Extra Strong.	\$15.00 per 1000																																																
Hardy Phlox,	2 00																																																
Hollyhocks, Strong 3 in. pot plants, dbl. white, pink, red and yellow.....	Per 100	3 00																																															
Ivy Leaved Geraniums, 6 good kinds, \$25 00 per 1000	3 00																																																
Lobelia, Crystal Palace Gem	2 00																																																
" Kathleen Mallard, 2 inch.....	3 00																																																
Lavender, 2 1/2 in. pots strong	3 00																																																
Swainsona, Alba	2 00																																																
Tradescantia, Dark Variegated.....	2 00																																																
Verbena, Red, White, Purple and Pink	2 00																																																

R. VINCENT JR. & SONS COMPANY, White Marsh, Md.

TUBEROSES

EXCELSIOR DWARF PEARL 3 x 4 \$.60 per 100, \$5.00 per 1000
4 x 6— 1.00 per 100, 8.00 per 1000

STUMPP & WALTER CO., 50 Barclay Street, NEW YORK

A HALF MILLION CALLA BULBS FOR SALE

CALLA ETHIOPICA BULBS, 7 to 8 inch circumference, \$65.00 per 1000
" " " " 5 to 7 " " " 40.00 " "
" " " " 3 to 5 " " " 25.00 "

250 at 1000 Rates, Freight Prepaid when Cash is sent with Order. Orders booked oov for July shipments.

A. MITTING, 17 to 23 Kennan St., Santa Cruz, Cal.

CANNAS

Send for our List and Prices

The CONARD & JONES CO.
WEST GROVE, PA.

Established 40 Years

Rose Hill Nurseries

New and Rare Plants

NEW ROCHELLE, N. Y.
New York Office, Siebrocht Building, 425 Fifth Avenue

Bedding Plants

All Kinds, Stocky, Good Size, Low Price. Can supply the Trade in quantity.

Just Received

A big shipment of ARAUCARIAS, PALMS, etc. Orders taken now for import for fall delivery.

A LEUTHY & CO.
PERKINS ST. NURSERIES
ROSLINDALE, MASS.

Dracena Indivisa, \$2 and \$5 per doz.
Vinca var. \$1.50 and \$2 per doz.
Canna Robusta, dark leaf, tall from flats, \$3 per C.
Cannas, dark and green leaf, dwarf from flats, \$3 per C.

E. & C. Woodman, Florists, Danvers, Mass.
TELEPHONE, 6106-2 DANVERS, MASS.

Gloire de Lorraine Begonia
2 1/4 inch pots, \$15.00 per 100
\$140.00 per 1000

Thomas Roland
Nahant - - Mass.

Ipomoea Noctiflora
Best pure white moonvine in market, very fragrant and as big as a saucer. On this variety we have a world-wide reputation as growers and shippers for the last twenty years. Price, 2 1-2 in. pots, \$5.00 per 100. 10,000 are now ready. 4 inch, nicely staked up, 12c.

CODFREY ASCHMANN,
1012 W. Ontario St., Philadelphia, Pa.

Myosotis, or Forget-me-not

Good lushy plants, 4 inch pots, \$6 00 per 100. Money with order.

Bedding Plants of all kinds

DENYS ZIRNGIEBEL, Needham, Mass.

CANNAS

Strong plants from pots. 40 leading varieties. \$5.00 per 100.

ESTATE OF DAVID FISHER, WOBURN, MASS

JAPANESE

THE YOKOHAMA NURSERY CO. NEW YORK.
31 BARCLAY STR.

LILIES
PLANTS
BAMBOO STAKES

JOHN BREITMEYER'S SONS

Cor. Miami and Gratiot Aves.
DETROIT, MICH.

Artistic Designs . . .
High Grade Cut Blooms

We cover all Michigan points and good
sections of Ohio, Indiana and Canada

William J. Smyth FLORIST

Cor. Michigan Ave. and 31st St., CHICAGO

We ship to all points in Illinois and Iowa.

Phones: Douglas 744, Douglas 523, Douglas 740

M. C. and J. E. HAUSWIRTH

232 Michigan Ave.

CHICAGO

AUDITORIUM ANNEX Tel. Harrison 585

SAMUEL MURRAY Florist

Coates House Conservatory
1017 BROADWAY, KANSAS CITY, MO
Both 'Phones 2670 Main

FRED C. WEBER FLORIST

4326-28 ST. LOUIS, MO.
OLIVE STREET
Established 1873
Long Distance Phone Bell Lindell 676



WASHINGTON,
D. C.

GUDE'S

The Far-Famed Flowers of TORONTO

Delivered on mail or telegraph order for
any occasion, in any part of the Dominion.

JOHN H. DUNLOP,
96 Yonge St., Toronto, Ont.

The Park Floral Co.

J. A. VALENTINE
Pres.

DENVER, COLORADO

WILLIAM L. ROCK FLOWER CO.

KANSAS CITY, MO.

will carefully execute orders for Kansas City
and any town in Missouri or Kansas.

Of Interest to Retail Florists

A DISTURBING PROBLEM.

It is unfortunate that the relationship of wholesale market to retailer in affairs of trade is of the unhappy nature that seems to exist in our great metropolis. Where the utmost harmony should prevail one finds much discontent and mistrust.

Not without just causes however, has the retailer been forced to complain of the burdensome handicap placed upon him. In all branches of trade it is the recognized right of a man to sell for the highest price obtainable, while a buyer is naturally desirous of purchasing at the lowest possible rates, but where goods are consigned as is the case with flowers, the consignee, whose sole profits are presumed to be his commissions, should in all fairness try to protect those of his daily patrons who are forced to pay the highest and not infrequently prohibitive prices. Men who have been loyal to the wholesaler, feel that discrimination has been exercised against them in the disposition of surplus stock to the street vender. While not presuming to advise as to the best method for disposing of unsold flowers, it seems hardly fair that the retailer be brought into direct competition with the street Arabs who peddle their wares for less than half the wholesale rates which the retailer is obliged to pay.

It may be claimed that there is no such thing as competition between shop-keepers and street peddlers. Let such a mind be disabused as speedily as possible. It would be refreshing to meet a retail florist who is not brought into daily contact with some customer who informs him that flowers equally good as those he may offer could be purchased in the streets for less than half the price he will ask. Is not this the natural outcome of a reckless output of overstock? Remonstrance availeth naught, for the wholesaler is ever ready with the question, "What are we to do with our surplus stock?"

Were flowers necessary for the preservation of human life the natural reply would be to sell for any price at all and be of service to those who are unable to afford better, but, of all luxuries, flowers can be most readily dispensed with; then why make them so exceedingly common as is found to be the case where they are peddled on street corners by most repulsive urchins at such ridiculously low prices as to fairly sicken passers by with the spectacle of too much bloom and too little decency?

Truly "the prize is light when too easily won," and as flowers are, or should be prizes, the adage holds well in their case. Why should not a minimum price be placed on all unsold stock thus giving the retailer a fair chance and forcing the street peddler to be a competitor on something like even terms, even though he be a shop within himself and without expense, save a 50c. license?

Under existing conditions a number of peddlers may band themselves together and purchase the entire un-

Chicago.

Established in 1857



1657-1659 Buckingham Place

L. O. Phone 558 Lake View. Send us your retail orders.

We have the best facilities in the city.

ALEX. McCONNELL

571 FIFTH AVENUE
NEW YORK CITY

Telegraphic orders forwarded to any part of the United States, Canada, and all principal cities of Europe. Orders transferred or intrusted by the trade to our selection for delivery on steamships or elsewhere receive special attention.

Telephone Calls, 487 and 488 38th St.

Cable Address, ALEXCONNELL

DAVID CLARKE'S SONS

Deliver orders from any part of the country to
New York City

Or OUT-GOING STEAMERS

Write or telegraph

2139-2141 Broadway, New York
Telephone 1552-1553 Columbus

M. A. BOWE

In the Heart of New York City

1294 Broadway

Tel. 2270. 38th St. NEW YORK

Our Motto -- The Golden Rule.

YOUNG & NUGENT

42 West 28 St., NEW YORK

"FLOWERS BY TELEGRAPH"

Flower Deliveries

In Brooklyn and other Long Island Points
New York City, New Jersey, etc. At Theatres,
Hotels, Steamers or Residences.

WILSON

Fulton St. and Greene Ave., Brooklyn, N.Y.

ALBANY, N. Y.

EYRES

Flowers or Design Work

DELIVERED IN ALBANY AND VICINITY
ON TELEGRAPHIC ORDER.

11 NORTH PEARL ST., ALBANY, N. Y.

YALE

Orders for flower deliveries to Yale College and all other Connecticut

points carefully filled. Delivered by
J. N. SHAMPIO & SONS
1026 CHAPEL STREET
HARTFORD, CONN.

JACOB SCHULZ, 644 Fourth Ave.,
LOUISVILLE, KY

Get Flowers of BEST QUALITY in season
delivered promptly to any address

Write, Telegraph or Telephone.
Cumberland and Home Phones 223 and 084

sold stock of a wholesale house at almost any price they may be pleased to offer. A retailer cannot obtain a fractional part of the same stock at these rates. Surely, no grower will willingly accept compensation for his product based upon returns from the sale of surplus material to street peddlers. Would it not be well then for him to suggest to his consignee the wisdom of disposing of his (the grower's) surplus stock at a price commensurate with the cost of production and without favor to any particular class?

To sum up the matter the grower is in truth the one to whom the retail shopkeeper looks for a remedy from this growing evil. Let him remember that the prices paid by the retail shopkeeper represent the profits with which he, the grower, appears to be satisfied, and not from the proceeds of the overplus sold at much less than the cost of production.

W. H. LONG.

New York City.

NEW RETAIL FLOWER STORES.

- J. J. Soper, Rockford, Ill.
- A. W. Darling, Rochester, N. Y.
- J. M. Holland, Mt. View Cemetery, Oakland, Cal.
- W. I. Davis, Homewood avenue, Pittsburg, Pa.
- J. W. Breakey, 3909 Cottage Grove avenue, Chicago.
- W. B. Agne, Penn and Negley avenues, Pittsburg, Pa.

BUSINESS CHANGES.

- J. A. Jegen, formerly 74 Washington street Chicago, is now located at 113 Dearborn street.
- George Smith will withdraw from the firm of Remick & Smith, S. Framingham, Mass., on June 1.
- D. H. Green, successor to Green & Baylis, is located at the greenhouses formerly run by Benjamin Connell, West Grove, Pa.
- W. R. Wheeler has purchased the business of the Manitou Greenhouses, Manitou, Colo., and will conduct it in his own name.
- Alexander Parks has purchased the greenhouse of the Home Culture Clubs at Northampton, Mass., and will continue the business.
- The Lyric Flower Shop is the name C. J. Breckman has given to his new place of business, corner of Seventh and A streets, Fort Smith, Ark.
- Carl Potocki, of Milwaukee avenue, Chicago, has purchased the Anthes Greenhouses on Lowell avenue, and his son Frank will assume the management of them.

Wired Toothpicks

Manufactured by

W. J. COWEE, BERLIN, N. Y.

10,000....\$1.75; 50,000....\$7.50. Sample free.
For sale by dealers

ROBERT J. DYSART,

Public Accountant and Auditor
Simple methods of correct accounting especially adapted for florists' use.
Books Balanced and Adjusted
Merchants Bank Building
28 STATE ST., - BOSTON
Telephone, Main 58.

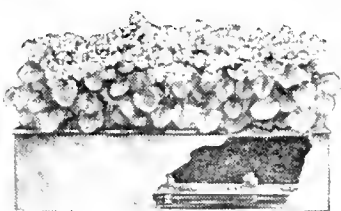

We manufacture
Self Watering Flower Boxes
for
Windows, Porches and Cemeteries
splendid for placing on
GRAVES

Water reservoir needs refilling but once in two weeks. Made of galvanized iron. Rust proof, leak proof, beautifully finished, and will last for many years. Made in all sizes.

Send \$2.00 for Sample Box

37 in. long and see how quickly you can double your money and also increase the sale of your plants. Illustrated booklet sent free on request

Illinois Heater & Manufacturing Co.
3946 Wentworth Ave., Chicago, Ill.

HART'S HANDY HANDLE

"At Easter-time, with a little chiffon decoration, and the Handle, we were able to increase the value of plants from 50% to 100%."— H. E. WILSON.

Write for descriptive circular and prices

GEO. B. HART, 24 Stone St., Rochester, N. Y.

PERSONAL.

C. E. Newton has taken a position with J. W. Beal at Hanover, Mass.

G. L. Taber, Glen St. Mary, Fla., is making a tour of the northern shore resorts.

Visitors in Boston: Theodore Outerbridge, Sunnyslads, Bermuda; Julius Roehrs, Jr., Rutherford, N. J.

George Smith, So. Framingham, Mass., will assume the duties of foreman for A. Mackay, Saxonville, Mass., about July 1.

Jackson Dawson, who has been quite sick for two weeks, is now sufficiently recovered so that his daughter Laura and son Walter think it safe to sail for England in a few days.

The friends of Charles L. Allen, the dean of Long Island horticulturists, are to celebrate his eightieth birthday at his residence at Queens, on June 13. Mr. Allen will read a paper on this occasion.

Announcement is made of the engagement of Miss Minnie M. Dawson, eldest daughter of Jackson Dawson, Arnold Arboretum, to Harold Hill Blossom of Newton Centre, Mass. The wedding will take place next fall.

NEWS NOTES.

The artist who sometime ago defrauded several Detroit florists by ordering floral designs and paying for them with bogus checks has been sentenced to imprisonment for a term of four years. He tried on the judge the scheme of arousing sympathy by shedding tears but the court was unsympathetic.

H. R. Hughes, the clever advertising florist of Chicago, is sending out a neat little folder entitled, "A Flower for Memory's Sake." It is a plea for a still greater floral observance of Memorial Day. A brief history of the beginning of the custom is given and the advertising end is cared for by the reproduction in picture of Memorial Day window displays by Mr. Hughes.

PROMPT DELIVERY IN BOSTON

AND ALL NEW ENGLAND POINTS
HOUGHTON & CLARK
396 Boylston St., Boston, Mass.



BOSTON'S BEST
In Quality and Design

Can be relied upon when you transfer your retail orders to

EDWARD MACMULKIN
194 Boylston Street, Boston

Send flower orders for delivery in
BOSTON

and all
NEW ENGLAND POINTS
THOS. F. CALVIN
124 Tremont St., Boston

TRANSFER

Your orders for flower or plant delivery in Eastern New England to

JULIUS A. ZINN,
2 Beacon St., Boston.
Fine Design Work a Specialty

ATLANTA FLORAL CO.
41 Peachtree Street, ATLANTA, GEORGIA.

In ordering goods please add "I saw it in HORTICULTURE."

"FOR JUNE WEDDINGS"
 Sweet Peas, very choice, \$1.00 per 100
 Valley, \$3.00 and \$4.00 per 100
 Beauties, best grade, \$3.00 per dozen
 Brides and Maids, choice quality
 Cattleyas
The Leo Niessen Company
 1209 Arch St., Philadelphia, Pa.
 Open from 7 a. m. to 8 p. m.

For June Weddings
CATTLEYAS
 Extra Stock, \$50 per 100.
VALLEY
 The Come-again kind, No. 1 \$3, Fancy \$4 per 100.
S. S. PENNOCK-MEEHAN CO.
 1608-1620 Ludlow St. PHILADELPHIA
 "The" Wholesale Florists of Philadelphia

EVERYTHING SEASONABLE IN
CUT FLOWERS
 EDWARD REID, Wholesale Florist
 1526 Ranstead St., PHILADELPHIA
 STORE CLOSES 8 P. M.

CHAS. W. McKELLAR
 51 WABASH AVE., CHICAGO
 Western Headquarters for Choice Orchids
 Valley, Roses and all Cut Flowers

PETER REINBERG
 WHOLESALE
CUT FLOWERS
 51 Wabash Av., Chicago, Ill.

CUT FLOWER BOXES
 EDWARDS FOLDING BOX CO
 MANUFACTURERS
 PHILADELPHIA, PA.

AMERICAN BEAUTY and all other ROSES
LILY OF THE VALLEY, CARNATIONS
WELCH BROS., 226 Devonshire St., Boston, Mass.

New Crop Dagger Ferns
 \$2.00 per 1000
 Case lots of 10 M. at \$1.50 per 1000
W. E. McKISSICK WHOLESALE FLORIST
 PHILADELPHIA
 1619-1621 RANSTEAD ST.

DAILY CONSIGNMENTS
 From 40 to 60 Growers
 We can care for your cutflower wants to advantage.
E. F. WINTERSON CO.
 45-47-49 WABASH AVE., CHICAGO

Rice Brothers
 115 N. 6th Street, MINNEAPOLIS, MINN.
WHOLESALE FLORISTS and SUPPLIES
 CUT FLOWERS received twice daily, and can fill your orders to your satisfaction. A complete line of Hardy Greens—WILD SMILAX, BOXWOOD, HARDY FANCY FERNS, GALAX LEAVES.
 Write for quotations on large quantities.

E. A. BEAVEN
 Southern Wild Smilax,
 Log Mosses,
 Natural and Perpetuated—at Wholesale
 EVERGREEN, ALABAMA.

TOWER HOTEL
 Niagara Falls, N. Y.
 Is soliciting your patronage during the S. A. F. Convention.
 Very truly yours,
M. J. HOENIG, Prop.

WHOLESALE FLOWER MARKETS—TRADE PRICES—Per 100 TO DEALERS ONLY

	CHICAGO May 25	TWIN CITIES May 25	PHILA. May 26	BOSTON May 28
ROSES				
Am. Beauty, Fancy and Special...	20.00 to 30.00	25.00 to 30.00	15.00 to 20.00	15.00 to 20.00
" " Extra.....	10.00 to 20.00	15.00 to 22.00	10.00 to 12.50	12.00 to 15.00
" " No. 1.....	10.00 to 15.00	10.00 to 12.00	8.00 to 10.00	10.00 to 10.00
" " Lower grades.....	4.00 to 6.00	6.00 to 8.00	2.00 to 4.00	1.00 to 4.00
Bride, 'Maid, Fancy & Special.....	6.00 to 8.00	6.00 to 8.00	6.00 to 8.00	5.00 to 6.00
" " Lower grades.....	4.00 to 6.00	2.00 to 5.00	1.00 to 4.00	1.00 to 2.00
Killarney, Richmond, Fan, & Sp.....	8.00 to 10.00	8.00 to 10.00	8.00 to 12.50	5.00 to 6.00
" " Lower grades.....	4.00 to 6.00	5.00 to 7.00	1.00 to 4.00	1.00 to 4.00
Chatenay, Fancy and Special.....	6.00 to 8.00	5.00 to 8.00	6.00 to 8.00	4.00 to 6.00
" " Lower grades.....	4.00 to 6.00	3.00 to 5.00	1.00 to 4.00	1.00 to 3.00
Kaiserin, Carnot.....	6.00 to 8.00	5.00 to 8.00	6.00 to 8.00	1.00 to 6.00
Golden Gate Ivory.....	6.00 to 8.00	3.00 to 8.00	1.00 to 4.00	1.00 to 6.00
CARNATIONS				
Fancy and Novelties.....	4.00 to 5.00	2.50 to 3.50	2.00 to 3.00	2.00 to 4.00
Ordinary.....	2.00 to 3.00 to 2.00	.50 to 1.00	1.00 to 2.00
MISCELLANEOUS				
Cattleyas.....	40.00 to 50.00	40.00 to 50.00	40.00 to 50.00	40.00 to 50.00
Lilies.....	8.00 to 12.50	6.00 to 8.00	10.00 to 12.50	6.00 to 8.00
Lily of the Valley.....	3.00 to 4.00	2.00 to 3.50	2.00 to 4.00	1.00 to 3.00
Daisies.....	.50 to 1.50	.75 to 1.25	.50 to 1.00	.50 to 1.00
Peas es.....	3.00 to 4.00	3.00 to 4.00	25 to .50	.25 to .50
Peonies.....	6.00 to 8.00	6.00 to 10.00	6.00 to 10.00	6.00 to 8.00
Gladiol.....	4.00 to 6.00	5.00 to 15.00	2.00 to 4.00	2.00 to 3.00
Mignonette.....	1.00 to 2.00	2.00 to 3.00	1.00 to 2.00	1.00 to 2.00
Gardenias.....	1.00 to 2.00	35.00 to 50.00	5.00 to 10.00	12.00 to 25.00
Lilac per bunch.....	.15 to .20	8.00 to 10.00 to50 to .70
Sweet Peas.....	.50 to 1.00	.60 to .75	.40 to .75	.25 to .50
Adiantum.....	.75 to 1.00	.75 to 1.00 to 1.00	1.00 to 1.55
Smilax.....	10.00 to 15.00	12.00 to 15.00	15.00 to 20.00	10.00 to 12.00
Asparagus Plumosus, strings.....	25.00 to 40.00	35.00 to 50.00	50.00 to 75.00	25.00 to 50.00
" " & Spren. (100 bchs.)	15.00 to 20.00	35.00 to 50.00	50.00 to	15.00 to 50.00

J. A. BUDLONG
 37-39 Randolph Street, CHICAGO.
 Roses and Carnations WHOLESALE CUT FLOWERS
 A Specialty..... GROWER of

REED & KELLER
 122 West 25th St., New York
Florists' Supplies
 We manufacture all our
 Metal Designs, Baskets, Wire Work & Novelties
 and are dealers in
 Glassware Decorative Grasses and Florists' Requisites

J. B. Murdoch & Co.
 Wholesale Florists
FLORISTS' SUPPLIES
 714 Penn Ave., PITTSBURG, PA.
 Long Distance Phone 1435 Court.

H. BAYERSDORFER & CO.

Known to the Trade for the past 30 years as the

Representative Florists' Supply House of America

Always first in the market with anything that is new, novel and appropriate.

FOR THE MONTH OF WEDDINGS AND GRADUATIONS

We have prepared for your needs with a stock of desirable and useful goods, unequalled in quality and extent anywhere on this continent and at prices that cannot be beaten. Orders by mail or telegraph will be filled immediately. Catalogue on application.

H. BAYERSDORFER & CO., 1129 Arch St., Philadelphia

FLOWER MARKET REPORTS

OBITUARY.

Mrs. Thomas Young.

Mrs. Thomas Young, who has been in failing health for some weeks, died at Clifton, N. J., on Friday, May 22, aged 81 years. The funeral was held on Sunday the 24th inst.

George McRae.

George McRae, a native of Scotland, who came to this country eight years ago, and has conducted a florist business at Cheswick, Pa., for the past six years, died on May 16, aged 68 years.

F. B. Forbes.

Francis B. Forbes, of Boston, died suddenly at his home, 114 Commonwealth avenue, on May 21. Mr. Forbes was born in New York in 1819. While living in China as an attache of the American legation he became interested in botany, and his work on the flora of the country, one of the most complete published, secured for him election as a fellow of the Linnean society of London, and a collection of the flora he made is now in the British museum.

MEMORIAL DAY.

By the flow of the inland river,
Whence the fleets of Iron have fled,
Where the blades of the grave grass
quiver,

Asleep are the ranks of the dead;
Under the sod and the dew,
Waiting the judgment day;
Under the one, the blue,
Under the other, the gray.

These in the robings of glory,
Those in the gloom of defeat,
All with the battle blood gory,
In the dusk of eternity meet;
Under the sod and the dew,
Waiting the judgment day;
Under the laurel, the blue,
Under the willow, the gray.

From the silence of sorrowful hours
The desolate mourners go,
Lovingly laden with flowers
Alike for the friend and the foe;
Under the sod and the dew,
Waiting the judgment day;
Under the roses, the blue,
Under the lilies, the gray.
—Verses from "The Blue and the Gray,"
by Francis Miles Finch.

BOSTON

This market, largely owing to the vagaries of the weather, finds itself almost swamped with material for Memorial Day demands. Carnations—the most essential flowers for the bouquet work and other decorative needs of the holiday—are very plentiful but of very inferior quality as a rule. There was a disposition on the part of the carnation growers, as per custom, to hold back their cut in anticipation of higher prices, but they were caught napping by the weather boss, and the stock so carefully hoarded in cellars and sundry secluded caverns without the attention of the ice man, came out in awful condition after imprisonment during Tuesday and Wednesday nights when the versatile thermometer recorded anywhere from 70 to 85 degrees. The result is an enormous load of half decayed stock in market which will prove the curse of the wholesale dealer and the cross of the retailer who gets it. We are sorry for all.

CHICAGO

A very hopeful feeling prevails regarding the outlook for Memorial Day trade. The stock certainly was never better for the time of the year, notwithstanding the unpropitious weather. Carnations are fine, roses in good shape, and peonies, snow balls, baby gladioli and pansies help out with the outdoor blooms. Unlike the feeling that prevailed before Easter, there seems to be no doubt but that the Memorial holiday would see all good flowers sell rapidly and many florists will probably wish their stock larger.

NEW YORK

The story of the wholesale market here this week is one of unprecedented inactivity and surplus stock. On all lines the story is the same and at present writing there is no promise of salvation through Memorial Day demands. In our price quotation columns we reproduce last week's figures but growers may find, in the final reporting, even lower rates prevailing. Cooler weather and shortened supply may, however, help in the adjustment of values for the latter half of the week.

PHILADELPHIA

There has been but little change in market conditions but more stock is coming in

which makes conditions appear not so good. Prospects are very fair for Memorial Day. Local peonies are in quantity (25th) with plenty more coming during the next few days. Fragrans, Andre Lauris, Rubra Triumphans, Festiva Maxima, and several others are plentiful. The peony men are much more fortunate this year than last when they were too late for memorial week. American Beauty roses in large supply, good quality, excellent demand for the season. Others medium quality, demand fair. Carnations—prices weaker and quality waning—demand was good towards the end of last week. Cattleyas are in larger supply with demand normal. Lilies much scarcer but enough for the demand. Lily of the valley is moving better and prices hold firm. The June wedding season which is now almost on us will have a good effect on this crop. The recent muggy weather had a bad effect on sweet peas. The gardenia market is full of the southern cut and prices are away down; but quality all right. Outside stock of all kinds is in large supply and not moving very briskly.

WASHINGTON

There is a perfect glut of peonies and sweet peas on the market now, but it is to be hoped that the 30th of May will relieve the pressure. Pond lilies are coming in in large quantities and of fine quality. This is one of the few crops that neither an abundance of rain or a drought affects. The outdoor roses have been injured to a great extent by the recent rains and mildew is again attacking the Rambler roses. Prices of carnations and all house-grown stuff have gone tumbling down and after this month they will be hard to dispose of at any price.

Detroit reports an abundance of outdoor flowers. Gladiolus America is offered in beautiful large spikes which find a ready sale at \$4 per dozen.

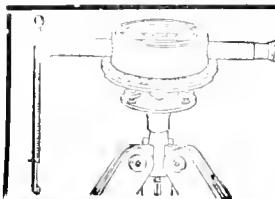

Bostrom Improved Builders' Levels and Farm Levels

For Park, Cemetery and Landscape Gardening use, take the place of expensive Engineering Instruments. Simple in construction, easily adjusted, more substantial and less cumbersome than the more elaborate and complicated instruments. Practical, up-to-date instrument that any one can use. Write for descriptive circulars and be convinced that this Level is necessary to complete your outfit. Builders' Level \$25.00. Farm Level \$12.50.

BOSTROM-BRADY MFG. CO., 139 Madison Avenue., ATLANTA, GA.

JOHN YOUNG
WHOLESALE FLORIST
 Finest American Beauties and Carnations
 51 West 28 St. - NEW YORK

FORD BROTHERS
 48 West 28th Street, NEW YORK
FINE ROSES FANCY CARNATIONS
 A Full Line of All CUT FLOWERS
 Telephone, 3870 or 3871 Madison Square

H. E. FROMENT,
 Wholesale Commission Florist,
 Choice Cut Flowers,
 57 West 28th St., :: NEW YORK.
 Telephones: 2200, 2201, Madison Square.

The Reliable Commission House
 Richmond Roses and Rich Flowers
 of all varieties
JOS. S. FENRICH
 110 W. 28th Street, New York
 Tel. 324-325 Madison Square

Alfred H. Langjahr
 All choice cut-flowers in season. Send for quotations. Correspondence with shippers of first-class stock invited.
 55 West 28th Street, New York.
 Telephones 4626-4627 Madison Square

JOHN I. RAYNOR
Wholesale Commission Florist · SELLING AGENT FOR LARGEST GROWERS
 A full line of Choice Cut Flower stock for all purposes. Comprises every variety grown for New York market, at current prices
 TEL. 1998 MADISON SQUARE 49 W. 28 St., New York City

Walter F. Sheridan
 Wholesale Commission Dealer in
CHOICE CUT FLOWERS
 39 West 28th Street, New York
 Telephone: 3532-3533 Madison Square

HEADQUARTERS FOR NOVELTIES
ORCHIDS A SPECIALTY
 THE HIGHEST GRADE OF VALLEY ALWAYS ON HAND
 CARNEDIAS, DAISIES, ROSES AND CARNATIONS
 Telephone
JAMES McMANUS, 759 Mad. Sq. 42 W. 28th St., New York

PHILIP F. KESSLER 55 & 57 W. 26th St., New York City
 Commission Dealer, Wholesale Buyer and Seller of
GUT FLOWERS
 Open from 5 a. m. to 6 p. m. Sunday till 10 a. m.
 Tel., 5243 and 2921 Madison Sq. Res., 345 J., Newtown.
Finest Lilies in the Market Every Day in the Year.

WHOLESALE COMMISSION FLORIST
J. K. ALLEN 106 W. 28 ST. NEW YORK
 Telephone 167 Madison Sq.
 OPEN 6 A.M. DAILY
 We have a good regular outlet for seasonable flowers

NEW YORK QUOTATIONS PER 100—TO DEALERS ONLY

	Last Half of Week ending May 23 1908	First Half of Week beginning May 25 1908		Last Half of Week ending May 23 1908	First Half of Week beginning May 25 1908
Roses			Cattleyas	20.00 to 40.00	25.00 to 47.00
Am. Beauty, fan and p.	10.00 to 15.00	8.00 to 15.00	Lilies	2.00 to 4.00	3.00 to 5.00
" extra	6.00 to 8.00	5.00 to 8.00	Lily of the Valley	1.00 to 3.00	1.00 to 2.00
" No. 1	4.00 to 6.00	3.00 to 5.00	Daisies	.25 to .50	.25 to .50
" Lower grades	.50 to 1.00	.50 to 2.00	Pansies	.15 to .25	.15 to .25
Bride, 'Maid, fan and sp.	3.00 to 5.00	3.00 to 5.00	Peonies	4.00 to 6.00	4.00 to 6.00
" lwr. grds.	.50 to 1.00	.50 to 1.00	Gladioli	4.00 to 8.00	4.00 to 8.00
Killrney, Richmond, fancy & spec	3.00 to 8.00	4.00 to 8.00	Mignonette	.50 to 1.00	.50 to 1.00
" lower grades	1.00 to 3.00	.50 to 2.00	Gardenias	2.00 to 12.00	3.00 to 15.00
Chatenay, Fancy and Special	3.00 to 5.00	3.00 to 6.00	Sweet Peas per 100 bunches	.15 to .25	.0 to .25
" Lower grades	.5 to 1.00	.50 to 2.00	Adiantum	.50 to .75 to .50
Kaiserin, Carn t.	.50 to 5.00	.50 to 5.00	Smilax	10.00 to 12.00	8.00 to 12.00
Golden Gate, Ivory	.50 to 4.00	.50 to 4.00	Asparagus Plumosus, strigs.	15.00 to 25.00	15.00 to 25.00
Carnations, Fancy and Novelties	1.00 to 2.00	1.00 to 2.00	" " & Spren. (100 bchs.)	15.00 to 25.00	15.00 to 25.00
" Ordinary	.50 to 1.00	.50 to 1.00			

Edward C. Horan
Wholesale Florist
 55 WEST 28th ST.
 Tel. 1462 Madison Square New York
 1463

TRAENDLY & SCHENCK
WHOLESALE FLORISTS
 Furnish best stock at fair prices all the year round Send for quotations on fall orders
 Tel. 798.799 Madison Sq. 44 West 28th Street, New York City

Moore, Hentz & Nash,
 Wholesale Commission Florists,
 55 and 57 West 26th Street,
 Telephone No. 756
 Madison Square. New York.

Alexander J. Guttman
THE WHOLESALE FLORIST OF NEW YORK
 34 WEST 28th STREET
 PHONES. 1664--1665 MADISON SQUARE
ENOUGH SAID



HARDY CUT FERNS

FANCY and DAGGER
Extra fine, \$1.75 per 1000. Bronze and Green Galax, \$1.25 per 1000. Leucothoe Sprays, \$1.00 per 100, \$7.50 per 1000.

Sphagnum Moss, Extra Large Bales, per bale, \$1.25. Fancy and Dagger Ferns our specialty. A trial order will convince you that we ship only first-class stock. Headquarters for Florists' supplies and wire work. All cut flowers in season. **BOXWOOD**, per bunch 35c, 50 lbs. \$7.50.

MICHIGAN CUT FLOWER EXCHANGE, INC., All 'phone connections 38-40 Broadway, Detroit, Mich.

Headquarters in Western New York
FOR
ROSES, CARNATIONS
And all kinds of Seasonable Flowers
Wm. F. Kasting Co.
Wholesale Commission Florist, also Dealer in Florists' Supplies and Wire Designs.
383-87 ELLICOTT ST. BUFFALO, N. Y.
Give us a trial. We can please you.

FRANK S. HICKS & CO.
Wholesale Florists.
Open Now for Consignments of Cut Flowers.
39 West 28th Street, - New York City
Tel. 2920 Mad. Sq.

WILLIAM H. KUEBLER
Brooklyn's Foremost and Best
WHOLESALE COMMISSION HOUSE
A First Class Market for all CUT FLOWERS
28 Willoughby St., Brooklyn, N. Y.
Tel. 4591 Main

 **Henry M. Robinson & Co.** 
Wholesale and Commission
— FLORISTS —

Flowers and Florists' Supplies
The best place in AMERICA to buy
BAY TREES
N. F. McCarthy & Co.
84 Hawley St., BOSTON, MASS.
Largest Dealers in Supplies in New England.

Hardy Cut Evergreens and Florists' Supplies
NEW CROP DAGGER AND FANCY FERNS, \$2.00 per M.
15 Province St. and 9 Chapman Place, Boston, Mass.

SAMUEL A. WOODROW
WHOLESALE PLANTSMAN
Palms, Large and Small Ferns, etc.
53 West 30th Street, NEW YORK
Telephona 2083 Madison

WHOLESALE FLOWER MARKETS. — PER 100. — TO DEALERS ONLY.

	CINCINNATI May 26	DETROIT May 27	BUFFALO May 25	PITTSBURG May 25
ROSES				
Am. Beauty, Fan. and Sp.....	20.00 to 25.00	25.00 to 30.00	25.00 to 25.00	20.00 to 25.00
“ Extra	15.00 to 20.00	18.00 to 15.00	15.00 to 20.00	10.50 to 15.00
“ No. 1	8.00 to 10.00	8.00 to 8.00	8.00 to 15.00	5.00 to 8.00
“ Lower grades.....	4.00 to 6.00	6.00 to 8.00	2.00 to 5.00	2.00 to 3.00
Bride, 'Maid, F. & S.....	5.00 to 6.00	8.00 to 10.00	6.00 to 8.00	6.00 to 8.00
“ Low. gr.	2.00 to 4.00	4.00 to 8.00	5.00 to 6.00	4.00 to 5.00
Killarney, Richmond, Fan. & Sp..	6.00 to 8.00	8.00 to 10.00	6.00 to 8.00	6.00 to 8.00
“ Lower grades.....	3.00 to 4.00	4.00 to 8.00	3.00 to 6.00	4.00 to 5.00
Chateaux, Fancy and Special.....	6.00 to 8.00	8.00 to 10.00	6.00 to 8.00	6.00 to 8.00
“ Lower grades.....	3.00 to 4.00	4.00 to 8.00	3.00 to 6.00	4.00 to 5.00
Kaiserin, Carnot.....	4.00 to 6.00	8.00 to 10.00	2.00 to 6.00	2.00 to 6.00
Golden Gate, Ivory.....	4.00 to 6.00	4.00 to 8.00	2.00 to 6.00	2.00 to 6.00
CARNATIONS				
Fancy and Novelties.....	2.50 to 3.00	3.00 to 4.00	3.00 to 4.00	2.00 to 3.00
Ordinary.....	1.00 to 2.00	2.00 to 3.00	1.50 to 2.00 to 1.00
MISCELLANEOUS				
Cattleyas.....	40.00 to 50.00	35.00 to 50.00	60.00 to 75.00 to 50.00
Lilies.....	8.00 to 10.00	10.00 to 12.00	12.00 to 15.00	10.00 to 12.50
Lily of the Valley.....	2.00 to 4.00	3.00 to 4.00	3.00 to 4.00	2.00 to 4.00
Daisies.....	.50 to 1.00	1.00 to 2.00	.50 to 1.00	1.00 to 1.50
Pansies.....	3.00 to 4.00	3.00 to 4.00	3.00 to 4.00 to .50
Peonies.....	6.00 to 8.00	8.00 to 12.00	6.00 to 8.00	5.00 to 8.00
Giadioli.....	4.00 to 6.00	10.00 to 15.00	4.00 to 6.00	4.00 to 6.00
Mignonne.....	1.00 to 2.00	1.00 to 2.00	1.00 to 2.00	2.00 to 3.00
Gardenias..... to 2.00	20.00 to 30.00	1.00 to 3.00	1.00 to 3.00
Lilac per bunch.....	.15 to .25	.10 to .25	.10 to .25	.10 to .25
Sweet Peas.....	.50 to .75	.50 to .75	.40 to .75	.50 to .75
Adiantum..... to 1.00 to 1.00	.50 to 1.00 to 1.25
Smilax.....	10.00 to 12.00	15.00 to 18.00 to 15.00	10.00 to 18.00
Asparagus Plumosus, strings.....	40.00 to 50.00	25.00 to 60.00	40.00 to 50.00	35.00 to 50.00
“ “ & Spren. (100 bchs.)	25.00 to 35.00	30.00 to 50.00	25.00 to 50.00	30.00 to 50.00

You will find something worth reading on every page of HORTICULTURE.

BOSTON FLORIST LETTER CO.
Manufacturers of FLORISTS' LETTERS



This wooden box nicely stained and varnished, 18x30x12, made in two sections, one for each size letter, given away with first order of 500 letters.
Block Letters, 1 1/2 or 2 inch size per 100, \$2.
Script Letters, 3. Fastener with each letter or word. Used by leading florists everywhere and for sale by all wholesale florists and supply dealers.
N. F. McCARTHY, Manager
66 Pearl Street, BOSTON, MASS.

H. G. BERNING
Wholesale Florist
1402 Pine Street, ST. LOUIS, MO.

A. MOLTZ
Will purchase flowers on order in N. Y. market and ship carefully at prevailing wholesale prices. Address
55-57 West 26th Street, New York City

MILLANG BROS.
WHOLESALE COMMISSION FLORISTS
41 West 28th Street
NEW YORK
Telephones 3860 Madison 3861

CLEARY'S HORTICULTURAL CO.
Management AMEROSE T. CLEARY
Wholesale Contracting, Jobbing, Auction
HORTICULTURAL PRODUCTS
of every description.
Consignments Received. Surplus Stock Converted.
62 Vesey St., NEW YORK

In writing to Advertisers kindly mention Horticulture

Buyer's Directory and Ready Reference Guide

Advertisements under this head, one cent a word. Initials count as words.

Regular advertisers in this issue are also listed under this classification without charge. Reference to List of Advertisers will indicate the respective pages.

Buyers failing to find what they want in this list will confer a favor by writing us and we will try to put them in communication with reliable dealers.

ACCOUNTANT

R. J. Dysart, 28 State St., Boston.
For page see List of Advertisers

ALTERNANTHERAS

Red Alternantheras at 40 cents per 100.
C. W. Moeckel, 17 Summer St., Fitchburg, Mass.

AQUATIC PLANTS

Water Lilies, Nymphaea odorata Rosea, \$2.00 per doz. W. I. Bodfish, West Barnstable, Mass.

ARAUCARIAS

A. Leuthy & Co., Perkins St. Nurseries, Roslindale, Mass.
For page see List of Advertisers.
John M. Kenzie, North Cambridge, Mass.
For page see List of Advertisers.

ASPARAGUS

A. N. Pierson, Cromwell, Conn.
Asparagus Plumosus Seedlings.
For page see List of Advertisers.
J. M. Thornburn & Co., 33 Barclay St., New York.
Plumosus Nanus and P. Robustus.
For page see List of Advertisers.

Hugh Graham Co. (David Rust, Receiver), 104 S. 13th St., Philadelphia.
Asparagus Plumosus.

Asparagus plumosus and Sprengerl, 2-in., strong, \$2.25 per 100. J. H. Dann & Son, Westfield, N. Y.

Asparagus Plumosa, 2 in. pots. Fine plants, \$3.00 per 100; \$25.00 per 1000. Cash with order or good reference. Erle Floral Co., Erle, Pa.; or, Wm. F. Kastling Co., 385 Ellcott St., Buffalo, N. Y.

ASTER SEED

Altimo Culture Co., Canfield, O.
For page see List of Advertisers.

AUCTION SALES

Cleary's Horticultural Co., 62 Vesey St., New York.
For page see List of Advertisers.
Wm. Elliott & Sons, 42 Vesey St., New York.
For page see List of Advertisers.

AZALEAS

A. Leuthy & Co., Perkins St. Nurseries, Roslindale, Mass.
For page see List of Advertisers.
August Rolker & Sons, New York, 31 Barclay St., or P. O. Box 752.
For page see List of Advertisers.

BAMBOO CANES

Yokohama Nursery Co., 31 Barclay Street, New York.
For page see List of Advertisers.

BAY TREES.

N. F. McCarthy & Co., 84 Hawley St., Boston.
For page see List of Advertisers.
2000 Bay and Box Trees in all sizes, Pyramid and Standards. Write for list Julius Roehrs, Rutherford, N. J.

BEDDING PLANTS

B. Vincent, Jr., & Sons Co., White Marsh, Maryland.
For page see List of Advertisers.
A. N. Pierson, Cromwell, Conn.
For page see List of Advertisers.
A. Leuthy & Co., Perkins St. Nurseries, Roslindale, Mass.
For page see List of Advertisers.
F. R. Pierson Co., Tarrytown-on-Hudson, N. Y.
For page see List of Advertisers.

BEDDING PLANTS - Continued

Godfrey Aschmann, 102 W. Ontario St., Phila., Pa.
For page see List of Advertisers.
Wm. S. Herzog, Morris Plains, N. J.
For page see List of Advertisers.

Mme. Sallerol, 212 in. pots, \$3 per 100. Compacta and Gracilis Lobelia, \$3 per 100. Golden Feather, \$2 Marguerite Carnations, \$3. Centaurea Gymnocarpa, \$3. J. B. Shurtleff & Son, Cushman Ave., Revere, Mass.

40,000 geraniums, 10 best standard sorts; 5000 Vinca variegata; Salvia; heliotrope, dark; feverfew, double white. Good stock, prices right. E. D. Kaulback & Son, Malden, Mass.

Geraniums, all the best varieties, \$8.00 to \$10.00 per 100; Verbenas, from 3 1/2-in. pots \$6.00 per 100; Single Petunias, fine stock, \$6.00 per 100; Vernon Petunia, pink, white and red, \$6.00 per 100; Phlox Drummondii, \$4.00 per 100; Colca Scandens, 4 in. fine, \$7.00 per 100; Tuberosus Begonias in colors, fine plants, \$10.00 to \$15.00 per 100. All of this stock is first class in every respect and satisfaction is guaranteed. Wiltrid Wheeler, Concord, Mass.

BEGONIAS

Thomas Roland, Nahant, Mass.
Gloire De Lorraine.
For page see List of Advertisers.
S. S. Skidelsky, 1741 N. 18th St., Phila.
Gloire de Lorraine.
For page see List of Advertisers.

Begonia "Agatha" (Veitch) (Improvement on Beg. Gloire de Lorraine) an easier grower, earlier flowering and of a more pleasing shade of soft, satiny pink; strong young plants from leaf cuttings, now ready; \$18.00 per 100.

Begonia "Gloire de Lorraine", strong, young plants from leaf cuttings, ready for delivery early in June; \$15.00 per 100; \$140.00 per 1000.

J. A. Peterson, McHenry Ave., Westwood, Cincinnati, O.
Tuberosus Begonias, best single, fine-tubers, \$1.50 per 100. Schlegel & Fottler Co., 26 South Market St., Boston.

Begonia Gloire Lorraine, strong plants from leaf cuttings, 2 1/4 inch pots, \$12.00 per 100; \$110.00 per 1000. Julius Roehrs, Rutherford, N. J.

BERBERIS THUNBERGII

Oak Hill Nurseries, Roslindale, Mass.
For page see List of Advertisers.

BOARD FILE

A. F. Lewis & Co., E. Boston, Mass.

BOILERS

BOILERS. "Burnham" Boilers made for greenhouse heating. Lord & Burnham, 1133 Broadway, N. Y.

Krosschell Bros. Co., 35 Erie St., Chicago.
For page see List of Advertisers.

BOUVARDIA HUMBOLDTII

Anderson & Williams, Waltham, Mass.

BUILDERS' AND FARM LEVELS

Bostrom-Brady Mfg. Co., 139 Madison Ave., Atlanta, Ga.
For page see List of Advertisers.

BUILDING MATERIAL

BUILDING MATERIAL of all description for All Cypress, Seal-Iron, Iron Frame or Truss Houses. Hot Bed Sash and Frames. Lord & Burnham Co., 1133 Broadway, N. Y.

BULBS AND TUBERS

Joseph Breck & Sons, 47-54 N. Market St., Boston.
For page see List of Advertisers.

J. M. Thornburn & Co., 33 Barclay St., New York.
For page see List of Advertisers.

A. T. Boddington, 342 W. 14th St., N. Y.
Cold Storage Lilies.
For page see List of Advertisers.

Rickards Bros., 37 East 19th St., New York.
For page see List of Advertisers.

H. F. Mitchell Co., Philadelphia.
For page see List of Advertisers.

H. E. Fliske Seed Co., Faneuil Hall Sq., Boston.
For page see List of Advertisers.

James Vick's Sons, Rochester, N. Y.
Pall Bulbs.
For page see List of Advertisers.

Aug. Rolker & Sons, 31 Barclay St., New York.
Seasonable Import Plants and Bulbs.
For page see List of Advertisers.

K. Velthuys, Hillegom, Holland,
Represented by Felix Bosch, 260 Clarendon St., Boston.
Bulbs French and Dutch.
For page see List of Advertisers.

W. J. Eldering & Son, Overveen, Haarlem, Holland.
High Grade Dutch Bulbs.
For page see List of Advertisers.

A. Mitting, 17-23 Kennan St., Santa Cruz, California.
Calla Bulbs.
For page see List of Advertisers.

CANNAS

The Conard & Jones Co., West Grove, Pa.
For page see List of Advertisers.

Godfrey Aschmann, 1012 W. Ontario St., Phila., Pa.
For page see List of Advertisers.

Estate of David Fisher, Woburn, Mass.
For page see List of Advertisers.

E. & C. Woodman, Danvers, Mass.
For page see List of Advertisers.
Stanted Cannas from sand, \$2; from pots, \$5. J. B. Shurtleff & Son, Cushman Ave., Revere, Mass.

CARE OF TREES

H. L. Frost & Co., White Plains, N. Y.; Arlington, Mass.
For page see List of Advertisers.

CARNATIONS

F. Dorner & Sons Co., Lafayette, Ind.
For page see List of Advertisers.

Chicago Carnation Co., Joliet, Ill.
For page see List of Advertisers.

John E. Haines, Bethlehem, Pa.
Carnations Imperial and Pink Imperial.
For page see List of Advertisers.

A. N. Pierson, Cromwell, Conn.
For page see List of Advertisers.

H. F. Littlefield, 552 Main St., Worcester, Mass.
For page see List of Advertisers.

Albert Roper, Tewksbury, Mass.
Carnation Bay State.
For page see List of Advertisers.

Carnation cuttings of all the leading varieties at the same price as any reliable firm. Write for prices before you look elsewhere. Wm. F. Kastling Co., 385 Ellcott St., Buffalo, N. Y.

CARNATIONS! FIELD GROWN!!
15,000 Enchantress and Winsor, ready for delivery July 1st. Orders filled in strict rotation. Order now and be first! Prices on application. We guarantee satisfaction. We lead in superb field grown stock.
WANOKA GREENHOUSES,
Barnesville, N. Y.

For List of Advertisers See Page 741

CAULIFLOWER AND CABBAGE SEED

H. Hartmann & Co., Copenhagen, Denmark.
For page see List of Advertisers.

CEMETERY FLOWER VASES
Wm. F. Kasting Co., 383-87 Ellicott St., Buffalo, N. Y.

CENTURY PLANTS

Two large specimen century plants in tubs. Price \$25.00 apiece. J. B. Shurtleff & Son, Revere, Mass.

CHRYSANTHEMUMS

Chas. H. Totty, Madison, N. J. Special Offer.
For page see List of Advertisers.
A. N. Pierson, Cromwell, Conn. For page see List of Advertisers.
H. F. Littlefield, 552 Main St., Worcester, Mass.
Rooted Cuttings.
For page see List of Advertisers.
H. L. Cameron, No. Cambridge, Mass. For page see List of Advertisers.

Have 100,000 fine young well-rooted 'Mums, cuttings of the best 60 commercial varieties. Send for our new and low price list. Satisfaction guaranteed. Wm. Ehmann, Jr., Corfu, N. Y.

Chrysanthemums ready: 2 1-2 inch strong stock of Tousef, Oct. Frost, Polly Rose, Wanamaker, and all standards, \$2 per 100, \$18 per M. New: 2 1-2. strong, Alice Roosevelt, Hankey, Clay Frick, Winter Cheer, Rosette, B. May, \$4 per 100, \$30 per M. Cash. Send for catalog. Harlowarden Greenhouses, Greenport, N. Y.

COBAEAS

Cobaea scandens from 4 in. pots, \$8.00 per 100. Wittbold Co., 1657 Buckingham Place, Chicago, Ill.

COLEUS

A. N. Pierson, Cromwell, Conn. For page see List of Advertisers.
Coleus, Golden Bedder, Verschaffeltii, and mixed Coleus, rooted cuttings, 60c. per 100; \$5.00 per 1000. Cash with order. J. E. Felthousen, Florist, Schenectady, N. Y.

CONIFERS

John Waterer & Sons, Ltd., American Nursery, Bagshot, Eng.
For page see List of Advertisers.

CUT FLOWER BOXES.

Edwards Folding Box Co., Philadelphia. For page see List of Advertisers.
Folding cut flower boxes, the best made. Write for list. Holton & Hunkel Co., Milwaukee, Wis.

CYCLAMEN.

Cyclamen, finest Giant strain, separate colors, once transplanted seedlings, 2c.; twice transplanted, 3c.; strong, from 2-in. pots, 4c. J. I. Schiller, 929 Fronty Ave., Toledo, O.

DAHLIAS

David Herbert & Son, Atco, N. J. For page see List of Advertisers.
R. Vincent, Jr. & Sons Co., White Marsh, Maryland.
For page see List of Advertisers.
Dahlia, balance of season, 25 named varieties, postpaid, \$1.00. Catalog free. J. L. Moore, Northboro, Mass.

Dahlia roots, named varieties, \$2.00 per 100; mixed, \$1.50 per 100. Edwin Bishop, Roslyn, Md.

Dahlias: About 2000 Cath. Duer, Kriemhilde, Brunnhilde, Suowlad, etc., \$3 per 100. Cash. Harlowarden Greenhouses, Greenport, N. Y.

DECORATIVE PLANTS

A. Leuthy & Co., Perkins St. Nurseries, Roslindale, Mass.
For page see List of Advertisers.
Godfrey Aschmann, 1012 W. Ontario St., Phila., Pa. For page see List of Advertisers.

DRACAENAS

E. & C. Woodman, Danvers, Mass. For page see List of Advertisers.
Dracaena indivisa: 4 in., \$2.00 per doz., \$12.00 per 100; 5 in., \$3.00 per doz., \$20.00 per 100; 6 in., \$6.00 per doz., \$30.00 per 100. Wittbold Co., 1657 Buckingham Place, Chicago, Ill.

ECHEVERIAS

Echeverias, \$18 per 1000, post paid. McDowell, Mexico City.

ELECTRIC CIRCULATOR

The Castle Co., 170 Summer St., Boston. For page see List of Advertisers.

FERNS

A. Leuthy & Co., Roslindale, Mass. For page see List of Advertisers.
H. H. Barrows & Son, Whitman, Mass. Nephrolepis Whitman. For page see List of Advertisers.
John Scott, Brooklyn, N. Y. For page see List of Advertisers.

FERTILIZERS

Pulverized Manure Co., 31 Union Stock Yards, Chicago, Ill.
Wizard Brand Cattle Manure. For page see List of Advertisers.
Thos. J. Grey & Co., 32 and 33 South Market St., Boston. High-Grade Scotch Soot. For page see List of Advertisers.
H. A. Dreer, 714 Chestnut St., Phila., Pa. Sheep Manure.

FLORAL PHOTOGRAPHS

Floral Photographs. Foley's 226-228 1-2 Bowery, New York.

FLORISTS' LETTERS.

Boston Florist Letter Co., 66 Pearl St., Boston, Mass. For page see List of Advertisers.

FLORISTS SUPPLIES

N. F. McCarthy & Co., 84 Hawley St., Boston. For page see List of Advertisers.
H. M. Robinson & Co., 15 Province St. and 9 Chapman Pl., Boston, Mass. For page see List of Advertisers.
Reed & Keller, 122 W. 25th St., New York. For page see List of Advertisers.
J. B. Murdoch & Co., 714 Penn Ave., Pittsburg, Pa. For page see List of Advertisers.

H. Bayersdorfer & Co., 1129 Arch St., Philadelphia. For page see List of Advertisers.

FLOWERS BY TELEGRAPH

Park Floral Co., Denver, Colo. For page see List of Advertisers.
J. N. Champlon & Co., 1026 Chapel St., New Haven, Conn. For page see List of Advertisers.
Guds Bros. Co., 1214 F St., Washington, D. C. For page see List of Advertisers.
Atlanta Floral Co., Atlanta, Ga. For page see List of Advertisers.

M. C. & J. E. Hauswirth, 232 Michigan Ave., Chicago. For page see List of Advertisers.

William J. Smyth, Michigan Ave. and 31st St., Chicago. For page see List of Advertisers.

George Wittbold Co., 1657-59 Buckingham Place, Chicago. For page see List of Advertisers.

Jacob Schulz, 644 4th Ave., Louisville, Ky. For page see List of Advertisers.

Thos. F. Galvin, 124 Tremont St., Boston. For page see List of Advertisers.

Julius A. Zinn, 2 Beacon St., Boston. For page see List of Advertisers.

Houghton & Clark, 396 Boylston St., Boston. For page see List of Advertisers.
Sidney Hoffman, 59-61 Massachusetts Ave., Boston. For page see List of Advertisers.

FLOWERS BY TELEGRAPH—Continued

Edward MacMullin, 194 Boylston St., Boston. For page see List of Advertisers.

J. Breitmeyer's Sons, Miami and Gratiot Aves., Detroit, Mich. For page see List of Advertisers.

Samuel Murray, 1017 Broadway, Kansas City, Mo. For page see List of Advertisers.

Wm. L. Rock Flower Co., 1116 Walnut St., Kansas City, Mo. For page see List of Advertisers.

Fred C. Weber, 4326-28 Olive St., St. Louis, Mo. For page see List of Advertisers.

H. G. Eyres, 11 N. Pearl St., Albany, N. Y. For page see List of Advertisers.

David Clarke's Sons, 2159-2141 Broadway, New York. For page see List of Advertisers.

Alex. McConnell, New York. For page see List of Advertisers.

M. A. Bowe, 1294 Broadway, New York. For page see List of Advertisers.

Robert G. Wilson, Fulton St. & Greene Av., Brooklyn, N. Y. For page see List of Advertisers.

Thomas Young, Jr., 500 Fifth Ave., N. Y. Young & Nugent, 42 W. 28th St., N. Y. For page see List of Advertisers.

J. H. Dunlop, 96 Yonge St., Toronto, Can. For page see List of Advertisers.

FLOWER BOXES

Illinois Heater & Mfg. Co., 3946 Wentworth Ave., Chicago, Ill. Self Watering for Windows, Porches and Cemeteries. For page see List of Advertisers.

FLOWER POTS

W. H. Ernest, 23th and M Sts., Washington, D. C. For page see List of Advertisers.
A. H. Hews & Co., Cambridge, Mass. For page see List of Advertisers.
Hilfinger Bros., Ft. Edward, N. Y. For page see List of Advertisers.
Red pots, seed pans, etc. The Peters & Reed Pottery Co., Zanesville, O.

FOXGLOVES

Foxglove in 3 colors, \$5.00 per 100. J. B. Shurtleff & Son, Cushman Ave., Revere, Mass.

GALAX

Michigan Cut Flower Co., 38 and 40 Broadway, Detroit, Mich. For page see List of Advertisers.

GARDENIA VEITCHI

Wm. Graham Co. (David Rust, Receiver), 104 S. 13th St., Phila.

GERANIUMS

R. Vincent Jr. & Sons Co., White Marsh, Md. New and Standard Varieties. For page see List of Advertisers.
Godfrey Aschmann, 1912 W. Ontario St., Phila., Pa. For page see List of Advertisers.

Wm. W. Edgar Co., Waverley, Mass. For page see List of Advertisers.
H. L. Cameron, No. Cambridge, Mass. For page see List of Advertisers.

I have a lot of good 4-in. Geraniums in the following varieties about 20,000 in all: Nutt, La Pilot, Flora Hill, Buchner, Mme. Sallerol and a few others at from \$7.00 to \$10.00 per 100. Also Alternantheras, mostly red, at \$2.00 per 100; Colens at \$2.50 per 100; and a few other varieties in plants. Hermann Schoenfeld, 86th and Crothers Ave., Elmwood, Philadelphia, Pa.

8,000 Geraniums in bud and bloom, out of 3 1/2 in. pots. Fine stock. S. A. Nutt, double white and mixed. Salvia, out of 3 1/2 in. pots, \$5.00 per 100. Cash with order. L. Cousius, Jr., Concord Junction, Mass.

Geraniums, 2-in., double red, \$1.50 per 100. J. H. Dann & Son, Westfield, N. Y.

In writing to Advertisers kindly mention Horticulture

GLADIOLI

Gladiolus, large flowering mixed, balance of season, \$1.00 per 100; postpaid. J. L. Moore, Northboro, Mass.

Gladiolus, choice mixed, 65c. per 100. W. I. Bodfish, West Barnstable, Mass.

GLASS

Boston Plate & Window Glass Co., Boston. For page see List of Advertisers.

Standard Plate Glass Co., 26-30 Sudbury St., Boston. For page see List of Advertisers.

S. Jacobs & Sons, 1365-79 Flushing Ave., Brooklyn, N. Y. For page see List of Advertisers.

Metropolitan Material Co., 1398-1408 Metropolitan Ave., Brooklyn, N. Y.

Foley Mfg. Co., Western Ave., between 25th & 26th Sts., Chicago.

Sharp, Partridge & Co., 22d & Lumber St., Chicago. For page see List of Advertisers.

Parshelsky Bros., 59 Montrose Ave., Brooklyn, N. Y.

Greenhouse glass, lowest prices. Johnston Glass Co., Hartford City, Ind.

GLASS, High Grade, Double Thick Greenhouse Glass. Lord & Burnham, 1133 Broadway, N. Y.

GLAZING POINT

H. A. Dreer, Philadelphia, Pa. For page see List of Advertisers.

GLAZING POINTS, Lord & Burnham Special Glazing Nulls (Points). Lord & Burnham, 1133 Broadway, N. Y.

GREENHOUSE BUILDING MATERIAL

Lord & Burnham Co., 1133 Broadway, New York. For page see List of Advertisers.

Pierson U-Bar Co., 1 Madison Sq., N. Y. For page see List of Advertisers.

A. T. Stearns Lumber Co., Neponset, Boston. For page see List of Advertisers.

King Construction Co., N. Tonawanda, New York. For page see List of Advertisers.

J. C. Moninger Co., 117 East Blackhawk St., Chicago, Ill. For page see List of Advertisers.

Foley Mfg. Co., Western Ave., between 25th & 26th Sts., Chicago. For page see List of Advertisers.

I. Casaldi, Summer Ave. and Erie R. R., Newark, N. J. For page see List of Advertisers.

Geo. B. Doane, 18 Midway St., Boston. Iron Pipe. For page see List of Advertisers.

S. Jacobs & Sons, 1365-79 Flushing Ave., Brooklyn, N. Y. For page see List of Advertisers.

Metropolitan Material Co., 1398-1408 Metropolitan Ave., Brooklyn, N. Y.

GREENHOUSE CONSTRUCTION

GREENHOUSE CONSTRUCTION, Semi Iron Greenhouse, New Truss Houses and Iron Frame Houses. Lord & Burnham, 1133 Broadway, N. Y.

J. A. Payne, 260-274 Culver Ave., Jersey City, N. J. For page see List of Advertisers.

I. Casaldi, Summer Ave. and Erie R. R., Newark, N. J. For page see List of Advertisers.

Foley Mfg. Co., Western Ave., between 25th & 26th Sts., Chicago. For page see List of Advertisers.

Wm. H. Lutton, West Side Avenue Sta., Jersey City, N. J. Curved Beless Eave. For page see List of Advertisers.

GUTTERS

GUTTERS, Cast Iron Gutters, L. & R Improved V Shaped Gutter with drip gutter attachment. Lord & Burnham, 1133 Broadway, N. Y.

HAIL INSURANCE

Florlats' Hall Assn. of America. J. G. Ealer, Saddle River, N. J. For page see List of Advertisers.

HARDY FERNS AND SUPPLIES

H. M. Robinson & Co., 15 Province St. and 9 Chapman Pl., Boston, Mass. For page see List of Advertisers.

Michigan Cut Flower Exchange, 38 and 40 Broadway, Detroit, Mich. Fancy Ferns. For page see List of Advertisers.

HART'S HANDY HANDLE

Geo. B. Hart, 24 Stone St., Rochester, N. Y. For page see List of Advertisers.

HEATING APPARATUS

Lord & Burnham Co., 1133 Broadway, New York. For page see List of Advertisers.

Pierson U-Bar Co., 1 Madison Sq., N. Y. For page see List of Advertisers.

John A. Payne, 260-274 Culver Ave., Jersey City, N. J. For page see List of Advertisers.

HEDGE PLANTS

Peter's Nursery, Knoxville, Tenn. For page see List of Advertisers.

HELIOTROPES.

Heliotropes, 2 in., 2c.; rooted cuttings, from soil, 75c. per 100. Edwin Bishop, Roslyn, Md.

HELP FURNISHED

Thos. H. Bambrick, 34 S. 7th St., Phila. For page see List of Advertisers.

HERBACEOUS PERENNIALS

Bay State Nurseries, No. Abington, Mass. For page see List of Advertisers.

New England Nurseries, Inc., Bedford, Mass.

P. Ouwerkerk, P. O. No. 2, Hoboken, N. J. For page see List of Advertisers.

HOLLYHOCKS

Field grown double Hollyhocks in separate colors, \$7. J. B. Shurtleff & Son, Cushman Ave., Revere, Mass.

HOT-BED SASH

The A. T. Stearns Lumber Co., Neponset, Mass. For page see List of Advertisers.

Pierson U-Bar Co., 1 Madison Sq., N. Y. For page see List of Advertisers.

Lord & Burnham Co., 1133 Broadway, N. Y. For page see List of Advertisers.

Foley Mfg. Co., Western Ave., between 25th & 26th Sts., Chicago.

HYDRANGEAS.

W. W. Edgar Co., Waverley, Mass. For page see List of Advertisers.

F. R. Pierson Co., Tarrytown-on Hudson, N. Y. Hydrangea Otaksa. For page see List of Advertisers.

Hydrangea Otaksa. We have a fine lot at 15c., 25c., 35c., 50c., 75c., \$1.00 and upwards to \$5.00 each. Witthold Co., 1677 Buckingham Place, Chicago, Ill.

INSECTICIDES.

Nicotinide kills all greenhouse pests. P. R. Palethorpe Co., Eleventh St., Owensboro, Ky. For page see List of Advertisers.

IRISES

J. M. Thorburn & Co., 33 Barclay St., New York. For page see List of Advertisers.

JAPANESE PLANTS

Yokohama Nursery Co., 31 Barclay St., New York. For page see List of Advertisers.

JUMPING BEANS

Jumping Beans, \$5 per 1000, post paid. McDowell, Mexico City.

KENTIAS

A. Leuthy & Co., Roslindale, Mass. For page see List of Advertisers.

LILIES

W. W. Edgar Co., Waverley, Mass. G. W. West, Shelly Bay, Bermuda. Lilium Harrisii.

E. M. Ingalls, Wholesale Florist, 43 Whiting St., Lynn, Mass. Tel. 505-3. In Boston Co-operative Flower Market, under Music Hall, Stall No. 167. Tel. Oxford 1571. Lilies, Verbenas, Asters and other Bedding Plants.

LOBELIAS

Double Lobelia, Kathleen Mallard, 2 1/2 in., 4c. Strong cuttings from soil, all full of buds and bloom. J. L. Stone, Trumansburg, N. Y.

MASTICA

F. O. Pierce Co., 12 W. Broadway, New York. For page see List of Advertisers.

MOON VINES

Godfrey Aschmann, 1012 W. Ontario St., Philadelphia. For page see List of Advertisers.

MYOSOTIS

Denys Zirugiebel, Needham, Mass. For page see List of Advertisers.

MYRTLE

Myrtle for cemetery planting, strong field grown clumps, \$2.00 per 100, or \$17.50 per 1000. Geo. A. Dhouau, East Walnut Hills, Cincinnati, O.

NEW AND RARE PLANTS

Rose Hill Nurseries, New Rochelle, N. Y. For page see List of Advertisers.

NICO-FUME

Kentucky Tobacco Product Co., Louisville, Ky.

NURSERY STOCK

John Waterer & Sons, Ltd., American Nursery, Bagshot, England. For page see List of Advertisers.

New England Nurseries, Bedford, Mass. Shrubs, Roses and Herbaceous Perennials. Specimen Pyramidal Box.

Bay State Nurseries, N. Abington, Mass. Herbaceous Perennials, Hardy Ornamental Trees.

For page see List of Advertisers.

Cleary's Horticultural Co., 62 Vesey St., New York. For page see List of Advertisers.

P. Ouwerkerk, 216 Jane St., Weehawken, Helghts, N. J. Holland Nursery Stock for Foreign. For page see List of Advertisers.

American Nursery Co., 150 Broadway, New York, N. Y. For page see List of Advertisers.

Peter's Nursery Co., Knoxville, Tenn. Live Fences; Amoor and California Privet. For page see List of Advertisers.

ORCHID PLANTS

Lager & Hurrell, Summit, N. J. For page see List of Advertisers.

Bander, St. Albans, England. Importers, Exporters, Growers, Hybridists. For page see List of Advertisers.

Julius Roehrs Co., Rutherford, N. J. For page see List of Advertisers.

Carrillo & Baldwin, Secaucus, N. J. For page see List of Advertisers.

Jos. A. Manda, 191 Valley Road, W. Orange, N. J. For page see List of Advertisers.

Ordonez Bros., Madison, N. J., Box 106. For page see List of Advertisers.

Largest stock in the country. Ask for prices. Julius Roehrs, Rutherford, N. J.

PALMS

A. Leuthy & Co., Perkins St. Nurseries, Roslindale, Mass. For page see List of Advertisers.

Robert Craig Co., Market and 49th Sts., Philadelphia, Pa. For page see List of Advertisers.

August Rolker & Sons, 31 Barclay St., New York. For page see List of Advertisers.

For List of Advertisers See Page 741

PALMS — Continued

Joseph Hancock Co., Wyncote, Pa.
Home-Grown Palms.
For page see List of Advertisers.

PAINT AND PUTTY

PAINT AND PUTTY: Ideal Greenhouse lead, Special Greenhouse Putty. Lord & Burnham, 1133 Broadway, N. Y.

PANSIES

250,000 Pansies, superb strain, ready now. Fall-transplanted pansies, in bud and bloom. A trial order will convince you that these are the best you ever handled. \$1.25 per 100; \$10.00 per 1000. Cash with order. Leonard Cousins, Jr., Concord Junction, Mass.

100,000 extra fine giant pansies, good, stocky, transplanted plants in bud and bloom, \$1.00 per 100; \$8.00 per 1000. Cash with order. M. A. Hough, Pansy Specialist, Milan, O.

Pansies, Superb Strain, 1.50 per 100; \$10.00 per 1000. Cash with order. Walter B. Cobb, Canton, Mass.

PATENTS

Siggers & Siggers, Washington, D. C.
For page see List of Advertisers.

PEAT

Orchid peat, Rotted peat, Azalea peat, Leaf-Mould, Live Sphagnum moss, Baled Sphagnum moss, Green Clump moss, etc. Jobbers' list on application. C. W. Brownell & Co., Walden, N. Y.

PELARGONIUMS

R. Vincent, Jr. & Sons Co., White Marsh, Maryland.
For page see List of Advertisers.

PEONIES

Wholesale Peony list for fall 1908 is now ready. J. F. Rosenfield, West Point, Neb.

One of the finest collections in America. Send 25 cts. in stamps for new edition of Peony Manual. C. S. Harrison's Select Nursery, York, Neb.

PHLOXES

Send 25 cts. in stamps for Phlox Manual. Fine mixed phloxes \$1.50 per 100. C. S. Harrison's Select Nursery, York, Neb.

PIPE AND FITTINGS

Foley Mfg. Co., between Western Ave. and 26th St., Chicago, Ill.
For page see List of Advertisers.

PIPE AND FITTINGS. Cast Iron and Wrought Pipe, Valves, Elbows, Pipe Hooks, Automatic Air Headers, etc. Lord & Burnham, 1133 Broadway, N. Y.

PLANT STAKES AND TRELISES

Seele's Patent, for roses, chrysanthemums, gladioli, tuberoses, dahlias, tomatoes, egg plants, etc. H. D. Seele & Sons, Msnuf., Elkhart, Ind.

POT HANGERS

Pot hangers, Kramer's \$1 doz. by exp. \$1.25 by mail. I. N. Kramer & Son, Cedar Rapids, Ia.

PRIMULA SEED

H. E. Fiske Seed Co., 13 Faneull Hall Sq., Boston.
For page see List of Advertisers.
O. V. Zangen, Hoboken, N. J.
For page see List of Advertisers.

RAFFIA

Raffia (colored), 20 beautiful shades. Samples free. H. H. Comey Co., Camden, N. J.; 810 Washburn Ave., Chicago, Ill.

RETAIL FLORISTS

Park Floral Co., Denver, Colo.
For page see List of Advertisers.
Gude Bros. Co., 1214 F St., Washington, D. C.
For page see List of Advertisers
Atlanta Floral Co., Atlanta, Ga.
For page see List of Advertisers.

RETAIL FLORISTS — Continued

M. C. & J. E. Hauswirth, 232 Michigan Ave., Chicago.
For page see List of Advertisers.
William J. Smyth, Michigan Ave. and 81st St., Chicago.
For page see List of Advertisers.
George Wittbold Co., 1657-59 Buckingham Place, Chicago.
For page see List of Advertisers.
Jacob Schulz, 644 4th Ave., Louisville, Ky.
For page see List of Advertisers
Thos. F. Galvin, 124 Tremont St., Boston.
For page see List of Advertisers.
Julius A. Zinn, 2 Beacon St., Boston.
For page see List of Advertisers.
Houghton & Clark, 396 Boylston St., Boston.
For page see List of Advertisers.
Sidney Hoffman, 59-61 Massachusetts Ave., Boston.
For page see List of Advertisers.
Edward MacMulkin, 194 Boylston St., Boston.
For page see List of Advertisers.
J. Bretmeyer's Sons, Detroit, Mich.
For page see List of Advertisers.
Samuel Murray, 1017 Broadway, Kansas City, Mo.
For page see List of Advertisers.
Wm. L. Rock Flower Co., 1116 Walnut St., Kansas City, Mo.
For page see List of Advertisers.
Fred C. Weber, 4326 Olive St., St. Louis, Mo.
For page see List of Advertisers.
J. N. Champlin & Co., 1026 Chapel St., New Haven, Conn.
For page see List of Advertisers.
H. G. Eyres, 11 N. Pearl St., Albany, N. Y.
For page see List of Advertisers.
David Clarke's Sons, 2139-2141 Broadway, New York.
For page see List of Advertisers.
Alex. McConnell, New York.
For page see List of Advertisers.
M. A. Bowe, 1294 Broadway, New York.
For page see List of Advertisers.
Robert G. Willson, Fulton St. and Greene Ave., Brooklyn, N. Y.
For page see List of Advertisers.
Thomas Young, Jr., 500 Fifth Ave., N. Y.
Young & Nugent, 42 W. 28th St., N. Y.
For page see List of Advertisers
J. H. Dunlop, 96 Yonge St., Toronto, Can.
For page see List of Advertisers.

RHODODENDRONS
John Waterer & Sons, Ltd., American Nursery, Bagshot, England.
For page see List of Advertisers.
P. Ouwerkerk, Hoboken, N. J.
For page see List of Advertisers.
New England Nurseries, Bedford, Mass.
Eastern Nurseries, Jamaica Plain, Mass.
Hardy Hybrid and Dwarf Rhododendrons.
For page see List of Advertisers.

ROSES
Julius Roehrs Co., Rutherford, N. J.
Rambler Rose, Newport Fairy.
New England Nurseries, Inc., Bedford, Mass.
Bay State Nurseries, N. Abington, Mass.
For page see List of Advertisers.
Robert Craig Co., Market and 49th Sts., Philadelphia, Pa.
For page see List of Advertisers.
Dingee-Conard Co., West Grove, Pa.
For page see List of Advertisers.
R. & J. Farquhar & Co., 6 and 7 South Market Street, Boston.
For page see List of Advertisers.
Anderson & Williams, Waltham, Mass.
The E. G. Hill Co., Richmond, Ind.
Roses, Rhea Reid, American Beauty.
For page see List of Advertisers.
Foehlmann Bros. Co., Morton Grove, Ill.
Mrs. Potter Palmer, Cardinal, Beauty.
For page see List of Advertisers.
P. R. Quinlan, Syracuse, N. Y.
Killarney, Richmond, Bridesmaids.
For page see List of Advertisers.

ROSES — Continued

P. Ouwerkerk, P. O. No. 2, Hoboken, N. J.
For page see List of Advertisers.
Henry A. Dreeer, 714 Chestnut St., Phila.
Potted Roses.
For page see List of Advertisers.
Crimson Ramblers, 2 year, on own roots, extra strong, at 7 cents. Gilbert Costich, Rochester, N. Y.
Low-budded roses, No. 1, \$95.00; No. 1-2, \$65.00 1000. H. T. Jones, Elizabeth, N. J.

RUBBER PLANTS

John McKenzie, North Cambridge, Mass.
For page see List of Advertisers.

S. A. F. CONVENTION ACCOMMODATIONS

Tower Hotel, Niagara Falls, N. Y.
For page see List of Advertisers.

SALVIAS

Cohanzie Carnation Co., New London, Ct.
Salvia Splendens.

SEEDS

T. J. Grey Co., 32 So. Market St., Boston, Mass.
For page see List of Advertisers.
Joseph Breck & Sons, 51 and 52 N. Market St., Boston, Mass.
For page see List of Advertisers.
W. Atlee Burpee & Co., Philadelphia.
For page see List of Advertisers.
J. M. Thorburn & Co., 33 Barclay St., N. Y.
For page see List of Advertisers.
A. T. Boddington, 342 W. 14th St., N. Y.
For page see List of Advertisers.
H. F. Mitchell Co., 1017 Market St., Phila.
For page see List of Advertisers.
James Vlek's Sons, Rochester, N. Y.
Vlek's Superb Pansy Seed.
For page see List of Advertisers.
Hjalmar Hartmann & Co., 12 Stormgade, Copenhagen, Denmark.
Cauliflower and Cabbage Seed.
For page see List of Advertisers.
Rieckards Bros., 37 E. 19th St., New York.
For page see List of Advertisers.
R. & J. Farquhar & Co., 6-7 So. Market St., Boston.
For page see List of Advertisers.
C. C. Morse & Co., 48-56 Jackson St., San Francisco, Cal.
For page see List of Advertisers.
Braslan Seed Growers Co., San Jose Cal.
For page see List of Advertisers.
H. E. Fiske Seed Co., Faneull Hall Bq., Boston.
Primula Fringed Sinensis.
For page see List of Advertisers.
O. V. Zangen, Hoboken, N. J.
For page see List of Advertisers.
John F. Rupp, Shiremanstown, Pa.
Chinese Primrose, Cineraria, Giant Pansy Seeds.
For page see List of Advertisers.

SLUG SHOT

Hammond's Paint & S. S. Works, Fishkill-on-Hudson, N. Y.
For page see List of Advertisers.

SMILAX

Smilax, choice young plants from fall; \$3.00 per 1000, 2000 for \$5.00, 5000 for \$10.00; 50c. per 100 by mail. F. A. Baller, Bloomington, Ill.

SPHAGNUM MOSS

Live Sphagnum moss, orchid peat and orchid baskets always on hand. Lager & Hurrell, Summit, N. J.

SPIREA

W. W. Edgar Co., Waverley, Mass.

SPRAYERS

Charles J. Jager Co., 281-85 Frsnkln St., Boston.
"Showermaker," \$1. Jos. Kopesay, So. Bend, Ind.

In writing to Advertisers kindly mention Horticulture

STEAM TRAP
E. H. Hippard, Youngstown, O.

SWEET PEAS
A. C. Zvolanek, Round Brook, N. J.
Winter Flowering.
For page see List of Advertisers.

TO-BAK-INE
E. H. Hunt, Genl. Agt., 76-78 Wabash Av.,
Chicago.
For page see List of Advertisers.

TUBEROSES
Stump & Walter Co., 50 Barclay St.,
New York.
For page see List of Advertisers.

No. 1 Pearl Tuberoses bulbs, \$5.00 per 100.
Schlegel & Fottier Co., 25 South
Market St., Boston.

VEGETABLE PLANTS
R. Vincent, Jr. & Sons Co., White Marsh,
Maryland.
For page see List of Advertisers.

Cabbage Plants—Early Jersey Wake-
field, Charleston Wakefield, Early Sum-
mer, nice plants, \$1.25 per 1,000; \$10.00 per
10,000. Dwarf Erfert Cauliflower plants,
\$4.00 per 1,000. Gladoli bulbs, large No. 1,
fine mixture, \$4.00 per 1,000. Cash
order quick. W. F. Allen, Salisbury, Md.

VENTILATING APPARATUS
Pierson U-Bar Co., 1 Madison Sq., N. Y.
For page see List of Advertisers.

Foley Mfg. Co., Western Ave., between
25th & 26th Sts., Chicago.
For page see List of Advertisers.

John A. Payne, 260-274 Culver Ave., Jersey
City, N. J.
For page see List of Advertisers.

The Advance Co., Richmond, Ind.
For page see List of Advertisers.

Quaker City Machine Co., Richmond, Ind.
20th Century Ventilating Arm.
For page see List of Advertisers.

VENTILATING MACHINERY, New
Model encased, self-oiling gear; Standard
Model Open Gear. Lord & Burnham, 1133
Broadway, N. Y.

VERBENAS
Mammoth Verbenas, fine large plants
from soil, coming in bud. 60c. per 100, by
mail; \$4.00 per 1000, by express. Samuel
Whitton, 15 Gray Ave., Utica, N. Y.

VIOLETS.
Lady Campbell violets, 25,000 extra fine,
sand-rooted cuttings, \$1.00 per 100, by
mail; \$7.00 per 1000, by express; 500 at
1000 rate. Satisfaction guaranteed. Field-
grown plants of Campbell and California
ready in August. Chas. Black, High-
town, N. J.

Marie Louise and Fairgair violet plants,
strong. February and March sand struck,
clean and free from disease, \$2.00 per 100;
\$15.00 per 1000. Will be ready May 15.
Cash with order, please. C. Lawritzen, Box
261 Rhinebeck, N. Y.

Marie Louise Violet cuttings well rooted;
satisfaction guaranteed, \$10.00 per 1000,
until June 15. Cash with order. James
Kearns, Rhinebeck, N. Y.

Violet cuttings, "Marla Louisa" Rho-
beck stock, rooted runners, May delivery
\$20.00 M. Wm. F. Kasting Co., 383 Ell-
cott St., Buffalo, N. Y.

California violets, extra strong, healthy
plants. \$1.00 per 100; \$7.00 per 1000. Fred
E. Holland, Highland, Ill.

VINCAS
E. & C. Woodman, Danvers, Mass.
For page see List of Advertisers.

Edmund Reardon, Cambridge, Mass.
Vinea Minor.
4-inch Vinea Variegata at \$10 per 100.
Joseph Labo, Joliet, Ill.

Vinea Variegata, extra strong, long vines
from 4 in., \$10.00 per 100; cash. Converse
Greenhouses, Webster, Mass.

WIREWORK
Reed & Keller, 122 W. 25th St., N. Y.
For page see List of Advertisers.

Wirework. Write for our catalogue.
Holton & Hunkel Co., Milwaukee, Wis.

William E. Hellscher's Wire Works, 38-40
Broadway, Detroit, Mich.

WIREWORK—Continued
Headquarters for wire work. Send for
list. Ball & Betz, 31 E. 3rd St., Cin-
cinnati, O.

WHOLESALE FLORISTS
Boston

N. F. McCarthy & Co., 84 Hawley St.,
Boston.
For page see List of Advertisers.

H. M. Robinson & Co., 15 Province St.
and 9 Chapman Pl., Boston.
For page see List of Advertisers.

Welch Bros., 228 Devonshire St., Boston.
For page see List of Advertisers.

Buffalo
Wm. F. Kasting Co., 383-87 Ellcott St.,
Buffalo, N. Y.
For page see List of Advertisers.

Chicago
Chas. W. McKellar, 51 Wabash Ave.,
Chicago.
For page see List of Advertisers.

Peter Reinberg, 51 Wabash Ave., Chicago.
For page see List of Advertisers.

E. F. Winterston Co., 45-49 Wabash Ave.,
Chicago.
For page see List of Advertisers.

J. A. Budding, 37-39 Randolph St., Chicago.
For page see List of Advertisers.

Detroit
Michigan Cut Flower Exchange, 38 and 40
Broadway, Detroit, Mich.
For page see List of Advertisers

Minneapolis
Rice Bros., 115 N. 6th St., Minneapolis,
Minn.
For page see List of Advertisers.

New York
J. K. Allen, 106 W. 28th St., New York.
For page see List of Advertisers.

J. S. Fenrich, 110 W. 28th St., New York.
For page see List of Advertisers.

Ford Bros., 48 W. 28th St., New York
For page see List of Advertisers

H. E. Froment, 57 W. 28th St., New York.
For page see List of Advertisers.

Alex. J. Guttman, 34 W. 28th St., New
York.
For page see List of Advertisers.

E. C. Horan, 55 W. 28th St., New York
For page see List of Advertisers

A. H. Langjahr, 55 W. 28th St., New York.
For page see List of Advertisers.

James McManus, 42 W. 28th St., New York
For page see List of Advertisers

John J. Raynor, 49 W. 28th St., New York
For page see List of Advertisers.

W. F. Sheridan, 39 W. 28th St., New York
For page see List of Advertisers.

Traendly & Schenck, 44 W. 28th St., New
York.
For page see List of Advertisers.

John Young, 51 W. 28th St., New York.
For page see List of Advertisers.

Moore, Hentz & Nash 55 and 57 W. 26th
St., New York.
For page see List of Advertisers.

Frank S. Hicks & Co., 39 W. 28th St.,
New York.
For page see List of Advertisers.

Wm. H. Kuebler, 28 Willoughby St.,
Brooklyn, N. Y.
For page see List of Advertisers.

New York—Continued
Phillip F. Kessler, 55 and 57 W. 26th St.,
New York.
For page see List of Advertisers.

A. Moltz, 55-57 W. 26th St., New York.
For page see List of Advertisers.

Millang Bros., 41 W. 25th St., New York.
For page see List of Advertisers.

Philadelphia
W. E. McKissick, 1619-1621 Ranstead St.,
Philadelphia, Pa.
For page see List of Advertisers.

Leo Nlessen Co., 1209 Arch St., Philadel-
phia, Pa.
For page see List of Advertisers.

The S. S. Pennock-Meehan Co., 1608-18
Ludlow St., Philadelphia, Pa.
For page see List of Advertisers.

Edward Reid, 1528 Ranstead St., Phila-
delphia, Pa.
For page see List of Advertisers.

Pittsburg
J. B. Murdoch & Co., 714 Penn Ave., Pitts-
burgh, Pa.
For page see List of Advertisers.

St. Louis
H. G. Berning, 1402 Pina St., St. Louis, Mo.
For page see List of Advertisers

WHOLESALE PLANTSMAN
Samuel A. Woodrow, 53 W. 30th St.,
New York.
For page see List of Advertisers.

WILD SMILAX
E. A. Beaven, Evergreen, Ala.
Southern Wild Smilax: Log Mosses.
For page see List of Advertisers.

New Offers in This Issue.

ASPARAGUS SEED.
Warren Shinn, Woodstown, N. J.
For page see List of Advertisers.

**AUCTION SALES DAILY (EXCEPT
MONDAY).**
The Fruit Auction Co., 2024 Franklin St.,
New York.
For page see List of Advertisers.

CANNAS, FERNS, CARNATIONS.
The F. R. Pierson Co., Tarrytown-on-
Hudson, N. Y.
For page see List of Advertisers.

RIVERTON HOSE.
Henry A. Dreer, 714 Chestnut St., Phila.
For page see List of Advertisers.

**SALVIA SPLENDENS: LEMON VER-
BENA.**
Cohanzie Carnation Co., New London, Conn.
For page see List of Advertisers.

**SUPPLIES FOR WEDDINGS AND
GRADUATIONS.**
H. Bayersdorfer & Co., Philadelphia.
For page see List of Advertisers.

TOMATO PLANTS.
W. W. Edgar Co., Waverley, Mass.
For page see List of Advertisers.

WIRED TOOTHPICKS.
W. J. Cowee, Berlin, N. Y.
For page see List of Advertisers.

SPECIAL SURPLUS LIST

These prices holding good only until present surplus is reduced.)

	Per 100	Per 100	
Begonia Rex, fine collection of varieties,	\$3.00	Baby Rambler Rose	\$2.00
Begonia Thurstoni and A. Daw	2.50	Clothilde Souper Rose	2.50
Fuchsias—strong stock, 8 varieties	2.50	Salvia Splendens	2.50
Violet, Prince of Wales	2.50	Ivy Geraniums	2.50
Verbenas, all colors	2.50	Dracena Indivisa	2.50
Pandanus Utilis, 2 1/2 in.	4.00	Pelargoniums, 3 in.	10.00
Pandanus Utilis 4 in.	8.00	Digitalis, two colors, field grown	4.00
Kaiserin Roses, Fresh propagation	3.00	Campanula in variety, field grown	4.00
		Shasta Daisy, in variety, field grown	3.00

THE STORRS & HARRISON CO., Painesville, Ohio

List of Advertisers

Advance, The Co.	743	Lager & Hurrell	723
Allen J. K.	734	Langjahr, Alfred H.	734
Altimo Culture Co.	727	Leuthy A. & Co.	729
American Nursery	716	Lord & Burnham Co.	744
American Nursery Co	716	Littlefield H. F.	715
Achmann G.	728-729	Lutton W. H.	743
Atlanta Floral Co.	734	Manda Jos. A.	723
Bambrick Thos. H.	741	MacMulklin E. A.	731
Barrows H. H. & Son	723	McCarthy N. F. & Co.	735
Bayersdorfer H. & Co.	733	McConnell Alex.	730
Bay State Nurseries	716	McKellar Charles W.	732
Beaven E. A.	732	McKenzie John	728
Berning H. G.	735	McKissock W. E.	732
Boddington A. T.	727	McManus Jas.	734
Boston Florist Letter		Michell H. F. Co.	725-727
Co.	725	Michigan Cut Flower	
Boston Plate and Win-		Exchange	735
dow Glass Co.	743	Milling Bros.	735
Bosch, Felix	728	Mitting, A.	729
Boström-Erady Mfg.		Moltz, A.	735
Co.	733	Moninger J. C.	743
Bowe, M. A.	730	Moore, Hentz & Nash	734
Braslan Seed Growers		Morse C. C. & Co.	727
Co.	727	Murdoch J. B. & Co.	732
Breck Joseph & Sons	727	Murray Samuel	730
Breimeyer's J. Sons	730	Niessen Leo. Co.	732
Bridgeman's Seed		Oak Hill Nurseries	716
Warehouse	727	Ordonez Bros.	723
Budlong J. A.	732	Ouwwerker P.	715
Burpee W. A. & Co	727	Palethorpe P. R. Co.	725
Cameron H. L.	715	Park Floral Co.	730
Carrillo & Baldwin	723	Payne John A.	741
Cassidy I.	743	Pennock-Meehan Co.	732
Castle Co.	742	Perkins St. Nurseries	79
Champion J. N. & Co.	730	Peter's Nursery Co.	745
Chicago Carnation		Pierce F. O. Co.	743
Co.	728	Pierson, A. N.	728
Clarke's David & Sons	730	Pierson F. R. Co.	716
Cleary's Horticultural		Pierson U Bar Co.	714
Co.	735	Pechlman Bros. Co.	716
Cohanzie Carnation		Pulverized Manure	70741
Greenhouses	728	Quaker City Machine	
Conard & Jones Co.	729	Co.	743
Cowee W. J.	731	Quinlan P. R.	715
Craig, Robt. Co.	715	Rawson W. W. & Co.	725
Dingee & Conard Co.	716	Raynor John I.	734
Doane Geo. B. & Son	743	Reed & Keller	732
Dorne F. Sons & Co	728	Reid Edw.	732
Dreer H. A.	743	Reinberg Peter	72
Dunlop John H.	730	Rice Bros.	732
Dysart R. J.	731	Rickards Bros.	727
Eastern Nurseries	716	Robinson H. M. & Co.	735
Edgar, W. W. Co.	729	Rock Wm. L. Flo. Co.	730
Edwards Folding Box		Roehrs Julius Co.	723
Co.	732	Rober Albert	728
Eldering W. J. & Son	728	Roland, Thomas	729
Elliott Wm. & Sons	726	Rolker August & Sons	
Esler J. G.	743	Rose Hill Nurseries	729
Ernest W. H.	741	Rupp J. F.	747
Eyres	730	Sander & Son	723
Farquhar R. & J. & Co.	715	Schulz Jacob	730
Fenrich J. S.	734	Scott, John	723
Fisher, Estate of		Sharp, Partridge & Co.	743
David	729	Sheridan W. F.	734
Flske, H. E. Seed Co.	727	Shun Warren	726
Foley Mfg. Co.	742	Siggers & Siggers	741
Ford Bros.	734	Situations & Wants	741
Froment H. F.	734	Skidelsky S. S.	723
Frost H. L. & Co.	716	Smyth Wm. J.	730
Fruit Auction Co. The	714	Standard Plate Glass	
Galvin Thos. F.	731	Co.	743
Grey T. J. Co.	727	Stearns A. T. Co.	743
Gude Bros. Co.	730	Storrs & Harrison	740
Gutman Alex. J.	734	Stump & Walter Co.	
Haerens A.	728		725-726
Hall Assn.	743	Thorburn J. M. & Co.	727
Haines, J. E.	718	Totty Charles H.	715
Hammond Paint & Stug		Tower Hotel	732
Shot Works	725	Traendly & Schenck	734
Hart, Geo. B.	731	Valentine, J. A.	730
Hartmann Hjalmar &		Velthuis K.	728
Co.	727	Vick's Jas. Sons	727
Hauswirth M. C. & J. E.	730	Vincent R. Jr. & Sons	
Heacock Joseph	728		726-729
Herbert David & Son	715	Waterer John & Sons	716
Herzog Wm. S.	723	Weathered Co.	744
Hews A. H. & Co.	741	Weber F. C.	730
Hicks Frank S. & Co	735	Welch Bros.	732
Hilfinger Bros.	741	Wilson	730
Hill, The E. G. Co.	716	Winterson, E. F. Co.	732
Hoenig M. J.	752	Withold Geo. Co.	730
Hoffman	731	Woodman E. & C.	729
Horan E. C.	734	Woodrow, Sam'l A.	735
Houghton & Clark	731	Yokohama Nursery Co.	731
Hunt E. H.	725	Young John	734
Illinois Heating &		Young & Nugent	730
Mfg. Co.	731	Zangen O. V.	727
Jacobs S. & Sons	743	Zinn J. A.	731
Kasting W. F.	735	Zirgichel Denys	726
Kessler, P. F.	734	Zovlanek A. C.	727
King Cons. Co.	743		
Kroeschell Bros. Co.	742		
Kuebler Wm H.	735		

JOHN A. PAYNE

Greenhouse Designer and Builder

260-274 Culver Ave., Jersey City

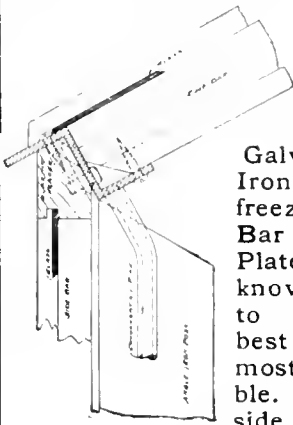

THE PAYNE

Galvanized Iron non-freezing Z Bar Eaves Plate is acknowledged to be the best and the most durable. No inside drip, no sockets to hold moisture around wood bars. Iron and wood frame greenhouses of every type—material only or erected. LET US ESTIMATE.

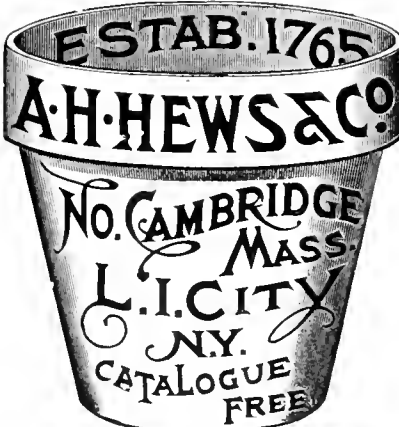

STANDARD FLOWER POTS

Packed in small crates, easy to handle.

	Price per crate		Price per crate
1500 2 1/4 "	\$4.88	120 7 1/2 in. pots in crate	\$4.20
1500 2 1/2 "	5.25	60 8 "	3.00
1500 3 "	6.00	HAND MADE	
1000 3 "	5.00	48 9 in. pots in crate	\$3.60
800 3 1/2 "	5.80	48 10 "	4.80
500 4 "	4.50	24 11 "	3.60
320 5 "	4.51	24 12 "	4.80
144 6 "	3.16	6 16 "	4.50

Seed pans, same price as pots. Send for price list of Cylinders for Cut flowers, Hanging Baskets, Lawn Vases, etc. Ten per cent. off for cash with order. Address **Hilfinger Bros., Pottery, Fort Edward, N. Y.** August Rolker & Sons, Agts., 81 Barclay St., N. Y. City.

Standard Flower POTS

If your greenhouses are within 500 miles of the Capitol, write us, we can save you money

W. H. ERNEST

28th and M Street WASHINGTON D. C.



Cattle Manure In Bags

Shredded or Pulverized
Best and safest manure for florists and greenhouse use, absolutely pure, no waste, no danger. Write for circulars and prices. The Pulverized Manure Co., 31 Union Stock Yards, Chicago



DREER'S
Florist Specialties.
New Brand - New Style.
Hose "RIVERTON"
Enrushed in lengths up to 500 ft. without seam or joint.
The HOSE for the FLORIST
1/2-inch, per ft., 15 c.
Keel of 50 ft., " 14 1/2 c.
2 Reels, 1000 ft., " 14 c.
1/2-inch, " 13 c.
Reels, 500 ft., " 12 1/2 c.
Couplings furnished.
HENRY A. DREER,
714 Chestnut St.,
PHILADELPHIA, PA.

PATENTS

Trademarks and Copyrights

Send your business direct to Washington. Saves time and insures better service. Personal attention guaranteed. Twenty-five years' active service. SPECIALTY: "Working on the Failure of Others."

SIGGERS & SIGGERS

PATENT LAWYERS

Box 9, National Union Building Washington, D. C.

SITUATIONS WANTED

GOOD MEN

When you need good men, skilled or unskilled, Write:

THOS. H. BAMBRICK

34 South 7th Street Philadelphia

Help of all kinds, including that for Florists, Nurserymen, Seedsmen and the Horticultural trade generally.

HELP WANTED WANTED

A thoroughly experienced man on Hardy and Half-hardy Shrubs and Trees, familiar with propagating, trimming and care.

Address S. M. A., care HORTICULTURE, 11 Hamilton Place, Boston.

TRAVELLER WANTED

by leading import house handling all kinds of foreign nursery and florists' stock—excepting Dutch Bulbs. Splendid opening for young man (under 25) with energy, judgment, intelligence and a fair knowledge of the business.

State age, qualifications and salary expected to "Import," care of Horticulture.

FOR SALE

GREENHOUSE FOR SALE.

About 14,000 feet of glass, two steam boilers, one hot water; easy communication to Boston and New York, 1-4 mile to depot; trolley freight passes greenhouses. Three acres of land, large two-story dwelling house, large wholesale and retail business. Books open for inspection. All health reason for selling. Address Horticulture, care of HORTICULTURE.

FOR SALE—Special—Glass for sale below cost. 16 x 24 double thick American A. & B. qualities, below cost, for immediate acceptance. Never such an opportunity offered before. Write Parshelsky Bros., 59 Montrose Ave., Brooklyn, N. Y.

Is Your Name In The Above List? If Not, Why Not?

BEFORE YOU BUILD GET FOLEY'S ESTIMATE

THE
FOLEY**GREENHOUSE MATERIALS**THE
BEST

ALL HEART SUN-DRIED GYPRESS. UNEQUALLED. CUT EXACT SIZE AND FIT. PERFECT WORK.

THE
FOLEY**VENTILATING APPARATUS**THE
BEST

ALWAYS SECURING PERFECT VENTILATION. ADAPTABLE TO ANY SIZE HOUSE. GET CIRCULARS.

THE
FOLEY**HOTBED SASH AND FRAMES**THE
BEST

SASH OPEN OR GLAZED. STANDARD SIZES IN STOCK. Get Our Figures and Suggestions on Your Proposed Work. 1908 Illustrated Catalogue Sent Postpaid.

SASH,
DOORS,
MOULDINGS,**ALL KINDS MILL WORK**INTERIOR
FINISH

FOR ANY WOODWORK USED IN CONSTRUCTING RESIDENCES, FACTORIES, SCHOOLS and PUBLIC BUILDINGS.

GET OUR FIGURES ON ANY JOB.

With our force of architects, draughtsmen, estimators and skilled workmen we can quickly and carefully fill, and promptly ship any order. Excellent work at lowest prices.

THE FOLEY MFG. CO., Chicago

OFFICES, FACTORY, SHEDS AND YARDS: WESTERN AV., BET. 25th AND 28th STS.

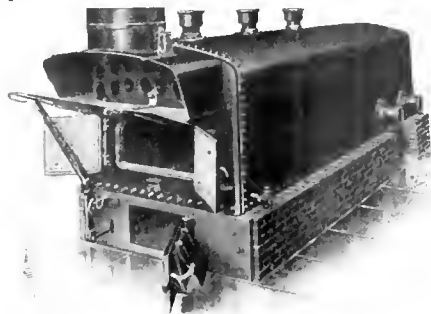
Expressions From Men Who Know**Greenhouses and Residence Heated by One Kroeschell Boiler**

G. Pasler, Buffalo, writes:

"Had different kinds of cast iron boilers. I am assured that I can save about one-third fuel with your boiler. I started firing October 10th and the fire never went out up to this time, May 13, 1907. This boiler heats both my dwelling and greenhouses and gives the best of satisfaction. My dwelling is about 40 feet from the boiler. Can recommend your boiler to anybody. It is the only greenhouse boiler."

Wouldn't Give the Kroeschell Boiler for a Dozen of the Others

Chas. W. Unglaub, Springfield, O., writes:

"I had a cast iron sectional boiler before I got yours, would not give yours for a dozen of the others. Your boiler is the **quickest heating boiler I ever saw**. I hardly ever have the damper over half open and the draft shut most of the time. I wish I had gotten it four years ago, when I got the sectional boiler. I would be ahead now. In the four years I had to buy a new section and four heads that had cracked, and I had to be right with the cast iron boiler, and I would have to fire every twenty or thirty minutes. **It took more coal than your boiler**. The cast iron boiler took much more attention and more coal and would be leaking half the winter. I want no more cast iron sectional boilers."

KROESCHELL BROS. CO., 35 ERIE ST., CHICAGO

The ELECTRIC CIRCULATOR

Is master of the situation.

It **MAKES** the water circulate.

It ensures uniform temperature.

Its work is positive regardless of weather.

It never gets out of order.

It saves coal.

It is serviceable in old houses.

It is helpful in new houses.

Its value has been fully demonstrated.

Its economy is conceded.

Lower values on greenhouse products make necessary lower running expenses. Write to us today and we will send you full information as to what the Circulator can do for you, and what it will cost.

THE CASTLE COMPANY*Heating Engineers*

170 Summer St., Boston, Mass.

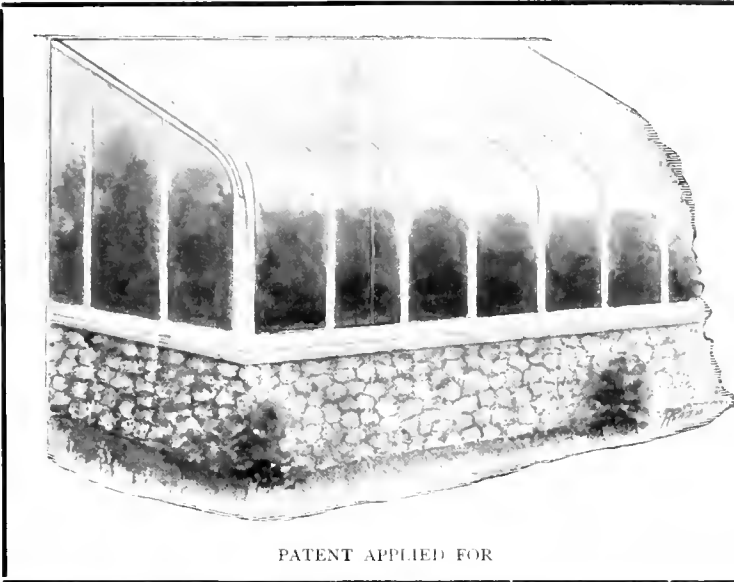

PATENT APPLIED FOR

Why My New Curved Iceless Eave is Far Superior to Anything on the Market Today

- 1st. No sash bars incased in iron, thereby eliminating all danger of bars decaying.
- 2nd. Can be used in conjunction with iron frame construction, thereby doing away with that very objectionable feature, "columns."
- 3rd. Roof bars with drip grooves, which act as conductors to carry away the condensation: Result, the driest roof ever used for greenhouse purposes.
- 4th. **THE MOST IMPORTANT OF THEM ALL.** The very small increase in cost over the ordinary style of construction which makes it possible to be used for commercial as well as private purposes.

William H. Lutton, Horticultural Architect and Builder
West Side Ave Station (C.R.R. of N.J.) Jersey City, N.J.

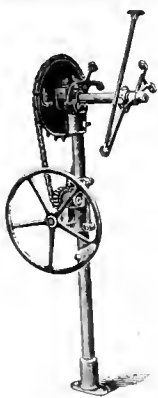

The Advance Ventilating Apparatus

All we need, all we ask is a trial in order to convince you that we have a high grade, easily operated ventilating apparatus, the best on the market and this too at reasonable prices and profits. Get our free estimates and printed matter.

The Advance Co.
RICHMOND, IND.

STANDARD PLATE GLASS CO.

Manufacturers—Importers—Jobbers

NOW IS THE TIME TO BUY

FRENCH OR AMERICAN GREENHOUSE GLASS

LOWEST PRICES ON REQUEST

26-30 Sudbury St. BOSTON, MASS. 61-63 Portland St.

GLASS Always Write Us Before Buying
SHARP, PARTRIDGE & CO.
22nd and Lumber Streets, CHICAGO
WE HAVE SOME SNAPS

IRON PIPE

SECOND HAND

WROUGHT IRON PIPE, for Steam, Water, Gas or Oil, Fences or Posts. All Sizes. Price Low.

GEO. B. DOANE & SON
18 Midway Street, BOSTON
Telephone, Main 4419

CYPRESS SASH BARS 82 feet or longer
HOT BED SASH
PECKY CYPRESS BENCH LUMBER

GREENHOUSES
ERECTED AND EQUIPPED COMPLETE IF DESIRED

Write for Circular "D" and Prices

The A. T. STEARNS LUMBER CO.
NEPONSET, BOSTON, MASS.

MASTICA
FOR Greenhouse Glazing
USE IT NOW.
F. O. PIERCE CO.
12 W Broadway and 227 Greenwich St. NEW YORK

BOSTON PLATE & WINDOW GLASS CO.
GREENHOUSE GLASS
German and American
261 to 287 A St., Boston 20-22 Canal St.

S. JACOBS & SONS
Manufacturers of GULF CYPRESS
GREENHOUSE MATERIAL
HOT-BED-SASH & FRAMES
Jobbers in **Boilers-Pipe-Fittings** and **GLASS** on which we can quote attractive prices. Disc on large quantities. We furnish everything for Greenhouse Building
1365-1379 Flushing Avenue
BROOKLYN, - NEW YORK

GREENHOUSE CONSTRUCTION LUMBER
John C. Moninger Co.
117 E. Blackhawk St., CHICAGO

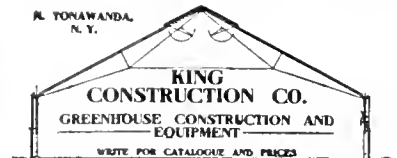

I. CASSIDY
Designer and Builder of

Iron and Wood Greenhouses
Factory: Summer Ave and Erie R. R.
Newark, N. J.



Evans 20th Century Arm

Will not twist your shafting pipe. Give it a trial and you will use no other. Three times the power of elbow arms.

Write for Catalogue
QUAKER CITY MACHINE CO.
Richmond, Ind.

Holds Glass Firmly
See the Point
PEERLESS
FULL SIZE N° 2
Glazing Points are the best. No rights or lefts. Box of 1,000 points 75 cts. postpaid.
HENRY A. DEER
714 Chestnut St., Phila., Pa.

The **FLORISTS' HAIL ASSOCIATION OF AMERICA**, insurer of 28,000,000 sq. ft. of glass. For particulars address **John C. Esler, Sec'y, Saddle River, N. J.**

READ! READ! READ!

The Magazine Feed Does It

The Water-Jacketed Magazine Feed of the "Spencer" Heater holds coal in reserve and feeds it as needed so that the Heater requires attention only once a day in ordinary weather, or twice in severe. The "Spencer" has the only Water-Jacketed Feed.

"Spencer" grates are raised in the centre, having same pitch at which coal comes from magazine, giving an even thickness of coal over the grate, causing the fire to burn evenly and the coal to slide from magazine as required.

It will pay you to discard your old heater, and begin **Saving Money** with a "Spencer." Write for catalogue, also ask for our Greenhouse Catalogue "The House of Greatest Sunlight."

WEATHERED COMPANY

P. O. Address Box 789, NEW YORK

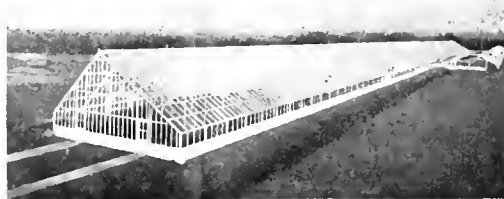

DRAUGHTS AND TEMPERATURE CONTROL IN WIDE HOUSES

NOT that there is any room for argument, but that argument still goes on: So when we saw in a recent issue of HORTICULTURE, Mr. Alexander Montgomery's expression over his signature, we to'd our Ad. man to print it again some time, because it struck the nail so square on the head. Here it is:

"If a house 40 feet wide and 700 feet long may be considered large, we can say, as far as our experience goes, that the fears of our critics are not well founded. In this structure the temperature and ventilation, both day and night, are under more perfect control than any other house on the place, and we are firmly convinced that, in this respect at least, it is very much superior to the eight small houses which it would require to cover the same amount of ground."

Our Section Iron Frame circular shows a 40 feet house along with several others. Send for this circular.

WE MAKE EVERY PART OF A GREENHOUSE BUT THE GLASS. WE SELL ANY PART.

LORD & BURNHAM CO.

MAIN SALES OFFICE:

1133 BROADWAY, NEW YORK

BOSTON:
819 Tremont Building

PHILADELPHIA:
1215 Filbert St.

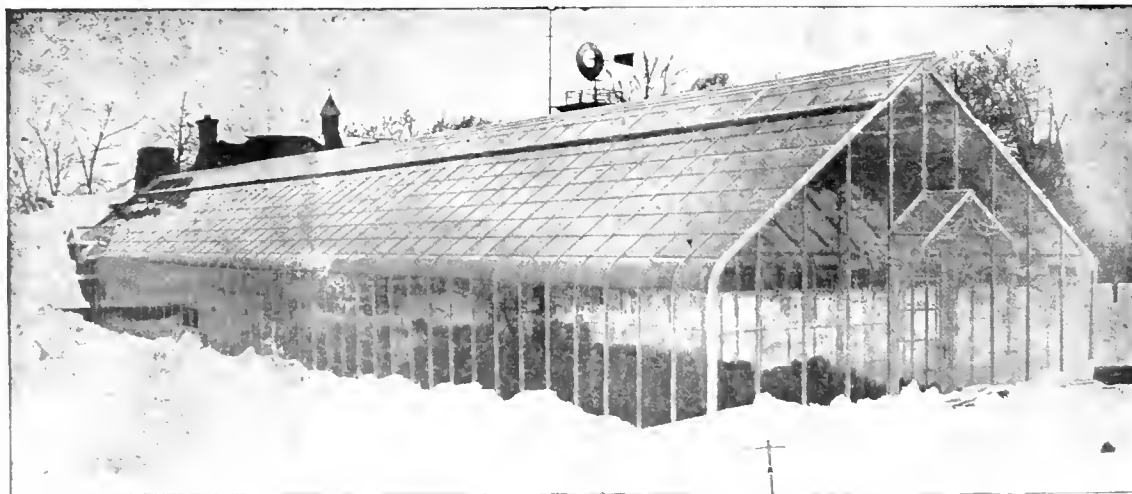

THEY HAVE ICE FREE ROOFS

No gutter to collect the ice—no plate for ice to hang to. The U-Bar with its curved eave, is ice and snow free, from ridge to foundation sill. It is the simplest, lightest, strongest, most durable, attractive and productive house built. They also cost less to maintain.

SEND FOR CATALOG.

The ideal construction for private estates, parks, public institutions and florists' showrooms

U-BAR GREENHOUSES

PIERSON

DESIGNERS AND BUILDERS



U-BAR CO.

1 MADISON AVE., NEW YORK

HORTICULTURE

Vol. VII. JUNE 6, 1908 No. 23



WHITE CATTLEYA MOSSIAE
Exhibited by Julius Rebers Co. before the Pennsylvania Horticultural Society, June 2, 1908

Devoted to the
**FLORIST, PLANTSMAN,
LANDSCAPE GARDENER,**
and
Kindred Interests

Published
EVERY SATURDAY
At 11 Hamilton Place,
BOSTON, MASS.
Subscription, \$1.00

GERANIUMS

Good Standard Varieties at \$2.00 per 100 and up to Novelties at \$1.00 each, from 2 inch pots. Our collection contains nearly 300 varieties. We will send 1000, 50 each of 20 varieties, our selection, for \$18.50. This is a splendid collection to stock up on. We have a good assortment in 3 inch pots at \$3.50 per 100.

A CORDIAL invitation is extended to all interested in Geraniums to visit us during May and June, to inspect our new stock houses containing over 60,000 plants, and especially to see our new show house: in it there are over 300 varieties in full bloom: a splendid opportunity to compare the newer introductions with the old standards, and to select stock for next season. We will make very liberal special prices on all orders booked during May and June for December delivery. We are at Cowenton on the B. & O. R. R., and at Chase on the Pennsy. We meet all trains.

PELARGONIUMS In good variety, 3-in pots, \$1.50 per dozen, \$6.00 per 100.
DAHLIA PLANTS From 2-10. pots, at \$2.00 per 100 to \$10.00 per 100. We will send 1000 in 20 varieties, our selection of good sorts in Cactus, Decorative or Show, for \$18.50.

HARDY CHRYSANTHEMUMS A splendid collection of over 75 kinds, Small-flowered or Button type, \$2.00 per 100. Large-flowered or Aster type \$3.00 per 100.

FOR LIST OF MISCELLANEOUS STOCK SEE ISSUE OF MAY 30th.

CANNAS

Strong Plants from 3 inch pots.

Jean Tissot, Brilliant vermilion, with bright orange shading, \$1.00 per doz., \$6.00 per 100.
President Meyers, Rich cherry carmine, bronze foliage, \$1.00 per doz., \$7.00 per 100.
Louisiana, Vivid scarlet, flowers often measure 7 inches, \$1.00 per doz., \$7.00 per 100.
Pennsylvania, Bright vermilion scarlet, tree bloomer, large, \$1.00 per doz., \$6.00 per 100.
Buttercup Deep buttercup yellow, almost pure, \$1.00 per doz., \$6.00 per 100.
J. D. Eisele Egandale, Alph. Bouvier, Mme. rozy, and Florence Vaughan, 60c per doz., \$4.00 per 100.

R. VINCENT JR. & SONS COMPANY, White Marsh, Md.

GERANIUMS

A Large Assortment of the Choicest Kinds.
From 3 1/2 in. pots, \$7.00 and \$8.00 per 100.

HYDRANGEAS

50c to \$5.00 each.

10,000 Tomato Plants

In fine condition. Write for Prices.

WM. W. EDGAR CO.,

Waverley, - - - - Mass.

TUBEROSES

EXCELSIOR DWARF PEARL 3 x 4 \$.60 per 100, \$5.00 per 1000
4 x 6—1.00 per 100, 8.00 per 1000

STUMPP & WALTER CO., 50 Barclay Street, NEW YORK

A HALF MILLION CALLA BULBS FOR SALE

CALLA ETHIOPICA BULBS, 7 to 8 inch circumference, \$65.00 per 1000
" " " 5 to 7 " " " 40.00 " "
" " " 3 to 5 " " " 25.00 " "
250 at 1000 Rates, Freight Prepaid when Cash is sent with Order. Orders booked now for July shipments.

A. MITTING, 17 to 23 Kennan St., Santa Cruz, Cal.

CANNAS

Send for our List and Prices

The CONARD & JONES CO. WEST GROVE, PA.

Rose Hill Nurseries

New and Rare Plants

NEW ROCHELLE, N. Y.

New York Office, Siebrecht Building, 425 Fifth Avenue

Surplus Plants

Per 100
300 *Salvia Splendens*, 4 in. - - \$5.00
1500 " " 3 in. - - 3.00
150 *Ageratum*, 2 1/2 in. - - 1.50
500 *Alyssum, Carpet of Snow*, 2 1/2 in. 2.50
750 *Alternanthera*, red, 2 in. - - 2.00
650 " yellow, 2 in. 2.00
100 *Cuphea*, 3 in. - - - - 2.00
200 *Verbenas*, 2 1/2 in. - - - - 1.50
300 *Canna* (Chas. Henderson) - 5.00
300 " (Florence Vaughan) - 5.00
1000 *Geraniums* (mostly S.A. Nutt) 3in 3.50
1000 " " " " 4in. 7.00
1500 *Madam Salleroy*, 3 in. - - 3.00

VERN L. SCHLURAFF ERIE, PA.

Bedding Plants

All Kinds, Stocky, Good Size, Low Price. Can supply the Trade in quantity.

Just Received

A big shipment of **ARAUCARIAS, PALMS, etc.** Orders taken now for import for fall delivery.

A LEUTHY & CO.

PERKINS ST. NURSERIES ROSLINDALE, MASS.

Dracena Indivisa, \$2 and \$5 per doz.
Vinca var. \$1.50 and \$2 per doz.
Canna Robusta, dark leaf, tall from flats, \$3 per C.

Cannas, dark and green leaf, dwarf from flats, \$3 per C.

E. & C. Woodman, Florists, Danvers, Mass.
TELEPHONE, 6106-D DANVERS, MASS.

Gloire de Lorraine Begonia

2 1/4 inch pots, \$15.00 per 100
\$140.00 per 1000

Thomas Roland, Nahant, Mass.

Ipomoea Noctiflora

Best pure white moonvine in market, very fragrant and as big as a saucer. On this variety we have a world-wide reputation as growers and shippers for the last twenty years. Price, 2 1-2 in. pots, \$5.00 per 100. 10,000 are now ready. 4 inch nicely staked up, 12c.

CODFREY ASCHMANN, 1012 W. Ontario St., Philadelphia, Pa.

50 000 CANNAS

BIG REDUCTION IN PRICES TO CLOSE OUT LARGE SURPLUS . . .

Standard Varieties, 75c. per 100 and up; also started plants, \$4.00 per 100 and up. Write for complete list with bargain prices.

RUDBECKIA (Golden Glow), \$1.50 per 100.
FRANK CUMMINGS BULB & PLANT CO., Meridian Miss.

CANNAS

Strong plants from pots. 49 leading varieties, \$5.00 per 100.

ESTATE OF DAVID FISHER, WOBURN, MASS.

JAPANESE
THE YOKOHAMA NURSERY CO.
31 BARCLAY STR. NEW YORK.
LILIES
PLANTS
BAMBOO STAKES

Like the Bee so is Godfrey Aschmann, the Philadelphia Hustler, Never Idle

IF YOU ARE IN MARKET FOR BEDDING PLANTS, GRAB THIS BARGAIN NOW OFFERED.

- Geraniums, S. A. Nutt, John Doyle and assorted varieties, 4-in. pots, per 100, \$7.00. Ageratum, dwarf blue, 3-in., per 100, \$4.00. Begonia Vernon, the best dark red varieties, and the fine improved Erfordi, the ever-blooming variety of Europe, 4-in., per 100, \$7.00; 3-in., per 100, \$5.00. Scarlet Sage, the true Bonfire of Clara Bedman, 4-in., \$7.00. Heliotrope, 4-in., per 100, \$7.00. Fuchsias, best varieties, 4-in., \$7.00 per 100. Ivy, English or Hardy, staked up, 3 feet high, 4-in., per 100, \$10.00. Vinca Variegata, 2 1/2-in., \$4.00. Cobaea Scandens, 4-in., staked up, per 100, \$8.00. Phlox Drummondii Grandiflora, 2 1/2 to 3-in., per 100, \$3.00. Lobelia, Dwarf and Trailing, 2 1/2-in., per 100, \$3.00. Tradescantia, 2 best varieties, 2 1/2-in., per 100, \$3.00. Ground Ivy, 2 1/2-in., per 100, \$3.00. Verbenas, best strain, all colors, 2 1/2-in., per 100, \$3.00. Sweet Alyssum, Little Gem or Carpet of Snow, 2 1/2-in., per 100, \$3.00. Summer Chrysanthemums, 3-in., best kinds, per 100, \$3.00. Nasturtiums, best dwarf, all colors, 3-in., per 100, \$3.00. Centaurea Gymnocarpa, Dusty Miller, 2 1/2-in., per 100, \$3.00. Torenia Fournieri, 2 1/2-in., per 100, \$3.00. Kenilworth Ivy, 2 1/2-in., per 100, \$3.00. Petunias, California Giant, 3-in., per 100, \$4.00; Inimitable or dwarf, 2 1/2 to 3-in., per 100, \$3.00. Marigolds or Tagetes, Eldorado, Gold King, 3-in., per 100, \$3.00. Best French Cannas, about 12 superior colors, by name, very strong plants, 4-in., per 100, \$7.00 to \$8.00. Clematis Jackmanni, late fall importation, 3 ft. high, nicely staked up, 35 to 40c. Araucaria Excelsa Glauca, 6 to 7-in. pots, last spring (1967) importation, 5 tiers, 25 to 40 inches high, same in width, 6 year old, suitable for lawns and porches, \$1.75, \$2.00, \$2.50, \$3.00, \$4.00 each. Imported two weeks ago 5000 Araucaria Excelsa, 3 tiers, 6-8-10-in. high, 40c; 10-12-14-in., 50c, 60c, 75c, \$1.00 each. Kentia Belmoreana, 6-in., 75c, \$1.00, \$1.25, \$2.00; 3 1/4-in., 20-25 inches high, 50c, 60c; 4 in., 35c. Forsteriana, large plants, \$2.50 each. 7-in., 40-50 inches high, \$3.00. Cosmos, separate colors, 3-in., 3 plants in 2 pot, per 100, \$3.00. Bay Trees, just arrived from Europe, Standard, 8-ft. high from top of tub, crown 30 inches in diameter, per pr., \$15.00.

Cash with order, please. All goods must travel at purchaser's risk

Godfrey Aschmann Importer, Wholesale Grower and Shipper of Pot Plants 1012 West Ontario St. Philadelphia, Pa.

Begonia Gloire de Lorraine Strong 2 1/2 in. pot plants, leaf cuttings, \$15 per 100, \$140 per 1000. Early June delivery or NOW if wanted. S. S. SKIDELSKY, 1741 No. 18th St. PHILADELPHIA

ROBERT CRAIG CO. ROSES, PALMS, and Novelties in Decorative Plants MARKET and 49th STREETS., PHILADELPHIA, PA.

PALMS Home Grown. KENTIA BELMOREANA and COCOS WEDDELIANA. Each Doz. 6-in. pot, 6 to 7 leaves, 22 to 24 in. \$1.00 \$12.00. 6-in. pot, 6 to 7 leaves, 24 to 26 in. 1.25 15.00. 6-in. pot, 6 to 7 leaves, 26 to 28 in. 1.50 18.00. 6-in. pot, 6 to 7 leaves, 30 to 36 in. 2.00 24.00. 7-in. pot, 6 to 7 leaves, 32 to 34 in. heavy 2.50 30.00. A FULL LINE OF KENTIAS (All Sizes) READY IN JULY. JOSEPH HEACOCK COMPANY, Wyncote, Pa.

BAY STATE The big sensation of all the recent Carnation Shows. A noble flower, white with carmine markings. Now Booking Orders for Next January Delivery. Rooted Cuttings, \$12.00 per 100, \$100.00 per 1000. ALBERT ROPER, Tewkesbury, Mass.

AZALEAS for fall delivery, the best that are grown, also PALMS for spring or fall delivery, furnished by August Haerens, Belgium; orders booked now.... AUGUST ROLKER & SONS, 31 Barclay Street, or P. O. Box 752, New York

COLEUS Verschaffeltii, Golden Queen, Fire Brand, Lord Palmerston, Queen Victoria, Beckwith's Gem. Prices of Rooted Cuttings by express, 60c. per 100; \$5 per 1000. Less than 250 of a variety will be charged at the 100 rate. Golden Bedder, Hero, Nessey, Pearl of Orange. 75c. per 100; \$6 per 1000. Less than 250 of a variety will be charged at the 100 rate. Fancy Varieties. A very fine assortment of twelve kinds not listed above. 75c. per 100; \$6 per 1000. 250, in assortment, our selection, at the 1000 rate. MISCELLANEOUS PLANTS AGERATUM, Stella Gurney, Princess Pauline. SALVIA Splendens, Bonfire. HELIOTROPE. Rooted cuttings, 75c. per 100; \$6 per 1000.

CARNATIONS Rooted Cuttings 100 1000 Winsor.....\$6.00 \$50.00 White Perfection..... 2.50 20.00 Rose Pink Enchantress..... 3.50 30.00 Enchantress..... 2.50 20.00 Queen Louise..... 2.50 20.00 From 2 1/4 inch pots, add \$1.00 per 100. ASPARAGUS PLUMOSUS MANUS SEEDLINGS From flats, \$1.00 per 1000. CHRYSANTHEMUMS Standard varieties, ready for shipment. Rooted cuttings, \$2 per 100; \$15 per 1000. Send for list. A. N. PIERSON, CROMWELL, CONN.

HYACINTHS, TULIPS, NARCISSI AND OTHER BULBS ROMAN HYACINTHS and the true PAPER WHITE GRANDIFLORA Ask for our Wholesale Trade List at Hillegom K. VELTHUYS, Hillegom, Holland Rep. by FELIX BOSGH, 260 Clarendon St., Boston.

ACHYRANTHES, or IRESINE WALLISII, Fine, bushy stock, 2 inch 2 cts, 3 inch 2 1/2 cts. ALTERNANTHERA AUREA NANA Large, bushy, as good as from pots, \$12.00 per 1000. Cash please, no C. O. D. FLORAL HILL GARDENS G. F. Nelpp, Prop. CHATHAM, N. J.

50,000 GERANIUMS large, spread-out plants in bud and bloom, 8 varieties, 3 1/2 inch, \$4.00; 3 inch, \$3.00 per 100. Not in bloom, \$3.50 and \$2.50 per 100. 50 000 COLEUS, 12 varieties, strong, 2 inch, \$1.50, 3 inch, \$2.50 per 100; \$14 and \$20 per 1000. SALVIA, 3 inch, \$2.50. CANNAS, Yellow and Red, strong, 3 inch, \$3.50 per 100. BEGONIA VERNON, 4 inch, in bloom, \$5 per 100. ... CASH ... WM. S. HERZOG, MORRIS PLAINS, N. J.

CARNATIONS F. DORNER & SONS CO. La Fayette, Ind.

ROOTED CARNATION CUTTINGS Only the Best Varieties CHICAGO CARNATION CO., JOLIET ILL.

400 3 1-2 inch SALVIA SPLENDENS Only \$4.00 per hundred 3 inch pots, \$3.00 per hundred 3 inch Lemon Verbena, \$7.00 per hundred COHANZIE CARNATION GREENHOUSES, New London, Conn.

JOHN E. HAINES Bethlehem, Pa. is the place to order rooted-cuttings of the following varieties for 1968. John E. Haines, red imperial variegated Pink imperial, Pink Enchantress, Light Pink } Per 100 Per 1000 \$6.00 \$50.00 Place your orders early for Jan. delivery.

In writing to Advertisers kindly mention Horticulture

THE ARISTOCRATS OF THE GARDEN

Beautiful at all Seasons of the Year and
the Glory of the Home Grounds in June

Hardy Hybrid Rhododendrons

We can supply all the reliable kinds for American planting, grafted on "Iron Clad" stocks, shapely, vigorous plants in any size or quantity required.

Write us now with full particulars as to situation and requirements and we shall be pleased to advise you.

JOHN WATERER & SON, Ltd.

Largest Shippers of Hardy Rhododendrons in the World
AMERICAN NURSERY, BAGSHOT, ENGLAND

The Roses that Win

MRS. POTTER PALMER, CARDINAL
American Beauty and Other Standard
Varieties. Rooted from Our Famous Stock.
Send for Prices.

POEHLMANN BROS. CO.
Morton Grove, Ill.

ROSES

A SPECIALTY

The Dingee & Conard Co. West Grove
PA.

RHEA REID

READY NOW, Own Root, \$30 per 100,
Grafted, \$35 per 100.

AMERICAN BEAUTY

Fine Young Stock, \$6 per 100, \$50 per 1000.

THE E. G. HILL CO., Richmond, Ind.

AMERICAN NURSERY CO., COMBIN- ING

FRED'K W. KELSEY, New York City
F. & F. NURSERIES, Springfield, N. J.
BLOODGOOD NURSERIES, Flushing, L. I.
N. J. & L. I. NURSERIES

We can supply you every need. Write for prices
Sales Department

150 BROADWAY, - NEW YORK

CARE OF TREES

12 years' experience. Endorsed by the United States Department of Agriculture. Graduates of Agricultural Colleges and Schools of Forestry. Field force 250 expert men. Everything to do with trees, — pruning, removing dead wood, treating and closing cavities, spraying for both insects and diseases, fertilizing, forest planting, tree moving, etc. Write us.

H. L. FROST & CO.

Landscape Foresters and Entomologists.

White Plains, N. Y. Arlington, Mass.

FINEST LOT OF

HARDY HYBRID RHODODENDRONS

ALSO DWARF RHODODENDRONS

ANDROMEDA FLORIBUNDA

READY FOR IMMEDIATE SHIPMENT

ORDER TODAY

EASTERN NURSERIES, JAMAICA PLAIN,
MASS.

HARDY NORTHERN GROWN NURSERY STOCK

At Reasonable Prices

FRUIT AND ORNAMENTAL TREES, SHRUBS, VINES, ROSES AND
HERBACEOUS PERENNIALS IN GREAT VARIETY

Catalogue and Price List for the asking

BAY STATE NURSERIES, NORTH ABINGTON, MASS.

LIVE FENCES

We believe we are the largest
growers of Hedge plants in
America—Privet our specialty
—can supply any quantity both

Amor River and California, strong plants, at \$25.00 per M. Other
varieties. Prices on application.

PETER'S NURSERY COMPANY, - Knoxville, Tenn.

Berberis Thunbergii

18 to 24-in., 12 to 18-in., all well branched and
good roots. 10,000 Vinca Minor (Grave Myr-
tle). 5000 Red Oak, 3 to 5 ft. Norway Spruce,
12 to 18-in.

OAK HILL NURSERIES, Roslindale Mass.

Hardy Rhododendrons Azaleas Con-
ifers, Clematis, H. P. Roses, Shrubs
and Herbaceous Plants from our
HOLLAND NURSERIES

Prices Moderate

P. OUWERKERK, 216 Jane St., Weehawken High
P. O. No. 1, Hoboken, N. J.

Notes from the Arnold Arboretum

During the next weeks the Rhododendrons will be in full bloom and the large group on Hemlock Hill will then be the most beautiful spot in the Arboretum. This group is admirably situated with its background of sombre Hemlock Spruces which not only afford a good shelter, but also set off effectively the rich colors of the flowering Rhododendrons. Besides those mentioned in the issue of May 23, the earliest of the Catawbiense hybrids have opened their flowers: these are *Lady Armstrong* with pink lilac flowers paler in the centre, *Atrosanguineum*, rich blood red, *Prometheus*, deep crimson, *Morion*, carmine and *Coriaceum* with white flowers spotted greenish yellow, a low, free-flowering shrub. The last named is apparently no Catawbiense hybrid, but is so closely related to *Rhododendron caucasicum*, that it may be considered a variety of that species. Another Caucasian species is the beautiful *R. Smirnowii* with carmine pink flowers and very distinct foliage, whitish tomentose beneath; it has proved perfectly hardy, but appears to be more particular as to the situation than other Rhododendrons: it apparently prefers partial shade.

Of the Rhododendrons of the Azalea-group the Ghent hybrids are now very showy with their brilliant colors, varying from orange and yellow to white, pink and red, also *R. molle* with pink flowers and its hybrids. A beautiful native species is *Rhododendron canescens* with its pink, deliciously fragrant flowers; it is much finer than *R. nudiflorum* with which it has been often confounded and which has paler pinkish white flowers.

Another noteworthy member of the Ericaceous family now in bloom is *Enkianthus campanulatus*, a slender shrub with nodding corymbs of rather small bell-shaped flowers whitish suffused with pink and marked conspicuously with red veins; it is not a very showy shrub, but very attractive on account of the peculiar coloring of the flowers. In autumn the foliage turns beautifully red. *Enkianthus japonicus* has white flowers and is a lower shrub of less ornamental value.

In the last issue *Lonicera Korolkovii* was inadvertently omitted from the enumeration of the Honeysuckles; it is certainly one of the finest species bearing light pink flowers in great profusion; the whole shrub has on account of its slender branches and small grayish green foliage a very light and airy appearance enhanced by the flowers being borne on slender stalks well above the foliage. It is perfectly hardy and much to be recommended.

The earliest of all Diervillas the *Diervilla praecox* mentioned in the issue of May 23 has given rise to early flowering hybrids with showier flowers; one of them is *Graecus* with bluish flowers and another *Conquerant* with carmine flowers.

Deutzia Lemoinei, one of the most beautiful Deutzias is now well known and appreciated, but still prettier are its hybrids with *D. discolor purpurascens*, which have pinkish flowers at least in bud; to this group, designated as *D. myriantha*, belong the varieties *Boule rose* and *Fleur de Pommier*.

Viburnum Sargentii may be considered but little dif-

ferent from the common Highbush Cranberry, but in the flowering state it is certainly prettier on account of the more profusely produced flower clusters with sterile flowers of a purer white, their color enhanced by the darker hue of the central fertile flowers caused by the purple anthers, while the flowers of *V. Opulus* have a yellowish tinge and yellow anthers; besides *V. Sargentii* differs in the more compact habit and the darker and firmer foliage. Unfortunately it lacks the most ornamental feature of *V. Opulus*, the large clusters of scarlet fruits, which are produced but sparingly in *V. Sargentii*. A snowball form of this species which may be looked for in time would be superior to the common Snowball which is much troubled with aphids and therefore not so much planted as it used to be. Another handsome Asiatic species is *V. Wrightii* with rather large bright green foliage and conspicuous clusters of white flowers followed by scarlet fruits in autumn. The native *V. pubescens* is now very attractive covered all over with white flower clusters; it is a compact shrub rarely exceeding five feet in height and turning deep purple in fall. For larger shrubberies *V. Lentago* is a very desirable shrub, it is now very handsome with its numerous clusters of yellowish white flowers.

Many species of *Crataegus* are now in bloom. The large collection of American Hawthorns planted on Peter's Hill, now numbering about five hundred different species, will in time afford a splendid opportunity to find out by actual comparison the ornamental qualities of the different species and to make a selection of the most desirable. Though the Hawthorns show in their appearance a comparative uniformity, they vary greatly in habit, spinosity, time of flowering, color of fruits and their persistency on the tree. The earliest as *Crataegus Arnoldiana*, *C. arkansana*, *C. coccineoides* and the European *C. nigra* flowered about a fortnight ago, while *C. nitida* with handsome lustrous foliage, the graceful *C. aprica* and *C. apifolia* and many others are now in bloom. Of foreign species may be mentioned besides the well known varieties of *C. Oryanthia* the Siberian *C. pinnatifida* to be recommended particularly for its handsome deeply cut foliage, and the large red fruits in autumn.

Alfred Rehder

British Horticulture

A USEFUL REPORT

For some years past valuable experimental work has been carried on through the generosity of the Duke of Bedford at his fruit farm in Woburn, Bedfordshire. The Duke, in conjunction with Mr. Spencer V. Pickering, F. R. S., has lately issued the eighth report, detailing the results of the experiments with insecticides and fungicides. It is explained that the aim has been to substitute as far as possible exact quantitative measurements for those more crude and unsatisfactory methods usually adopted, in which the impression produced on the mind of the observer is the sole standard by which the success or failure of an insecticide is gauged. The principle adopted has been to ascertain what is the action of an insecticide when it is applied under the simplest and most perfect conditions possible, as in the laboratory, and then to ascertain the results when it is

applied in the plantation under ordinary conditions of practice. Besides investigations into the effect of certain insecticides, the report contains an account of an examination of the nature of the substances constituting some of these insecticides, which, in the case of emulsion has resulted in the introduction of a class of emulsifiers which may be substituted with great advantage for soap and such like substances, especially in cases where soap causes much trouble and inconvenience; whilst an investigation into the chemistry of Bordeaux mixture has resulted in showing how the cost of that substance may be reduced by three-fifths without in any way diminishing its effectiveness.

GARDENERS' BENEVOLENCE

A noble work has been accomplished amongst British gardeners in the various organizations on benevolent lines. The efforts of the working gardeners in subscribing funds for philanthropic purposes have been supplemented by the liberality of the wealthy owners of estates. The Royal Gardeners' Orphan Fund, which is one of the leading charities, has just celebrated its 21st birthday. At the festival dinner the Duke of Bedford, the owner of Covent Garden market, presided, and subscribed £250 to the funds. The total received in connection with the festival was £1,385. The fund is at present supporting 116 orphans, and last year £100 was distributed in excess of any previous year. In celebration of the 21st anniversary, Mr. Edward Sherwood, the treasurer, has in conjunction with his father and brother, decided to contribute a sum of £200 to provide a special section. The president, at the festival, eulogized the objects of the charity. No darker shadow, the Duke said, could hang over a man than the knowledge that he might at his death leave children for whom there was no provision. It was customary to regard the children of gardeners as encumbrances, simply because they did not tend to the convenience of the employer, but it was wrong to penalize a man because he was a husband and father. It was unwise from a national point of view to do anything that was calculated to encourage a low birth-rate. He explained that the cost of management of the fund is fully met by the income from the invested capital, all the revenue arising from the subscriptions being directly available for relief purposes. Most of the leading nurserymen are found amongst the society's supporters.

CARNATION CULTURE

Some interesting experiments have been carried out at Messrs. Hugh Low & Co.'s nurseries. Mr. Montagu C. Allwood reports in planting out perpetual-flowering carnations for summer blooming in the open. "We carried out rather extensive experiments in this direction," Mr. Allwood states, "and found that plants put out in early May produced an abundance of flowers during the summer, and were much more satisfactory than the ordinary border carnation. It is no small advantage in being able to plant out carnations in May for summer flowering, because with the ordinary border carnation autumn or very early spring planting has to be done to ensure summer bloom. The best class of plant

for summer flowering is that from a 5-inch pot, with from eight to ten growths, that which has produced an early winter crop of bloom or which has been wintered in a cold frame giving similar results. Early-rooted cuttings in 3-inch pots with four or five growths also give quite good results. During the last winter we had quite a large collection of perpetual-flowering carnations planted out in the open along with ordinary border varieties, and hardly a plant has succumbed to the severity of the season, and are now making good growth for flowering again. In an absolutely cold frame we wintered several thousands of perpetual-flowering carnations in 5-inch pots, and these withstood 15 degrees of frost and scarcely a plant has died." Mr. Allwood is an active member of the Perpetual Flowering Carnation Society, and the author of a valuable work on carnation culture.

W. H. Adsett.

Wood Preservation for Horticulturists

During the coming year the government will extend its experiments in wood preservation to cover an entirely new field—the work of treating greenhouse timbers.

Decay takes place rapidly under the conditions of high humidity always found in greenhouses and horticultural buildings. The timber at present employed in the construction of such buildings consists for the most part of the naturally durable and relatively expensive kinds, such as select cypress and white pine. By a preservation treatment other cheaper and less durable species can probably be successfully substituted for them, and this can be done at a low cost.

In the treatment of greenhouse timbers several problems must be solved. For instance, it is desirable that the wood used in greenhouse construction be painted white in order that it will reflect as much light as possible. Consequently, a preservation must be used which will allow the treated timbers to hold a coat of white paint. Again, no preservative can be used which will in any degree affect the growing plants. It is probable, however, that these difficulties can be overcome, and the completion of the investigation will be watched with interest.

The investigations in wood preservation by the use of creosote, which is nothing more than the dead oil of coal tar and of zinc chloride, is considered of such importance by the government that one branch of a bureau in the United States Department of Agriculture—the "Office of Wood Preservation" in the Forest Service—is given over entirely to the work of experiments in co-operation with railroad companies, mining corporations and individuals who desire to prolong the life of the timber which they use. Advice and practical assistance are furnished all who request it of the Forester at Washington.

The Misuse of Fertilizers and Manures in the Greenhouse

The article in HORTICULTURE of April 25, 1908, entitled "Soluble Fertilizers" was of interest to us, and since our experiments and observations have been for a number of years along this line we could not refrain from offering a few suggestions.

The statement attributed to Dr. Galloway that "fully as good results could be secured by the use of good composts alone as where chemical manures were applied" is in harmony with the views and practices of market gardeners who have grown lettuce in the same soil for many years without using fertilizers. Most market gardeners would not accept commercial fertilizers for greenhouse use if offered to them free of cost, and in this they are wise as more harm than good results from the use of fertilizers in a greenhouse as ordinarily applied. Not a single winter passes without our receiving at the Experiment Station inquiries from growers of greenhouse crops concerning certain peculiar diseases and abnormal growths with which they are unfamiliar, and which can be attributed to the injudicious use of fertilizers and manures, and it would seem that this type of injury is on the increase, for during the past winter we have received more complaints than ever before.

The effects of over-manuring on crops may be seen in many ways, as is evident from the pathological symptoms displayed; in short it may be stated that the stimulating effects of plant foods are specific as well as manifold. The writer has had occasion to examine a number of plants with symptoms characteristic of the misuse of fertilizers. We have also applied fertilizers at various times to greenhouse crops with little or no benefit, and as a matter of fact greenhouse soils, when properly prepared, contain a sufficient amount of plant food to carry the crop through. There are undoubtedly instances of fertilizers being applied to bring about certain definite reactions on the part of the plant which would be desirable, but there are many other cases where such reactions would prove undesirable, if not injurious. It is well known that rose-men who prepare their soil according to the standard formula and apply liquid manure throughout the season make a practice of changing the soil each year, and the question naturally arises, "Why do they change the soil?" This question was asked a few years ago in one of the leading florists' journals but none of the replies were satisfactory. Our investigations have shown that the constant application of manure to soil already well supplied with available plant food renders it unfit for growing roses a second year. On the other hand, horse manure can be applied to lettuce soils every year in liberal quantities, and the longer such soils are used the better they are, showing that there is much difference between the nature of the manure and the amount applied, and there is a difference in the manurial requirements of the crop.

One of the commercial fertilizers which has caused more trouble than any other in greenhouses is nitrate of

soda, but its effects on different plants are by no means the same. In some plants it causes a rupturing of the tissue adjacent to the vascular bundles or it may cause a curling or crinkling of the leaf, and this often results from a distorted growth of the vascular bundles. These peculiar pathological conditions have been noticed on a number of different plants. In other cases it inhibits root absorption, while transpiration may be active, causing a wilting of the tender parts of the leaves which will eventually turn brown and die (top-burn, tip-burn, sun scorch, etc.).

A few years ago the writer described a trouble called leaf and stem curl caused by over manuring, and this trouble can easily be produced experimentally and is often seen in greenhouses. It may also be brought about by an excess of nitrate of soda and a too liberal use of hen, pig and cow manure. The use of fertilizers may also force the plants to such an extent that they are rendered susceptible to certain pathological organisms, and they occasionally throw all their energies into the formation of vines and leaves, to the exclusion of flowers and fruit. There is a marked difference in the susceptibility of different crops to feeding. According to our investigations, the cucumber appears to suffer the most from the misuse of fertilizers and manures, although a soil which has been fertilized to such an extent that it is unsuited to cucumbers will grow a good tomato crop.

The normal requirements of greenhouse plants as regards plant food is a subject in need of investigation, and is being studied at the present time by my colleague, Mr. Haskins, whose article entitled "Chemical Study of Some Greenhouse Soils" accompanies this. The writer has observed the effects of over manuring and the injudicious use of fertilizers on the lily, cyclamen, celery, tomato, lettuce, cucumber, soya bean, etc. There are innumerable instances which might be mentioned where abnormal food relations exist which cause various pathological conditions in the organism, but a discussion of these individual cases would require too much space. It is not our purpose to contend at the present time that commercial fertilizers cannot be used in a greenhouse on certain crops to advantage by the cautious and skilled grower, but we are led to believe from the large number of cases of the misuse of fertilizers and manures which are constantly being brought to our attention that it is better for greenhouse men to follow the advice given in Bulletin No. 123 of the Massachusetts Agricultural Experiment Station, namely:

"Unless one has an extended knowledge of soil fertility, it is best to avoid the use of all commercial fertilizers in greenhouse culture. Greenhouse soils are as a rule provided with so much plant food that the addition of fertilizers is not absolutely necessary, and the formulas given for outdoor crops cannot be followed. If it is desired to use fertilizers on greenhouse crops, consult station or other authorities familiar with the subject of soil fertility."

G. E. Stone

Amherst, Mass.

HORTICULTURE

VOL. VII

JUNE 6, 1908

NO. 23

PUBLISHED WEEKLY BY
HORTICULTURE PUBLISHING CO.
 11 Hamilton Place, Boston, Mass.

Telephone, Oxford 292
 WM. J. STEWART, Editor and Manager

SUBSCRIPTION PRICE

One Year, in advance, \$1.00: To Foreign Countries, 2.00. To Canada, \$1.50
ADVERTISING RATES

Per Inch, 30 inches to page \$1.00.
 Discounts on Contracts for consecutive insertions, as follows:
 One month (4 times) 5 per cent., three months (13 times) 10 per cent.,
 six months (26 times) 20 per cent., one year (52 times) 30 per cent.
 Page and half page spaces, special rates on application.

Entered as second-class matter December 8, 1904, at the Post Office at Boston, Mass., under the Act of Congress of March 3, 1879.

CONTENTS

COVER ILLUSTRATION—White Cattleya Mossiae.	
NOTES FROM THE ARNOLD ARBORETUM—Alfred Rehder	719
BRITISH HORTICULTURE—W. H. Adsett	749
WOOD PRESERVATION FOR HORTICULTURISTS.	750
THE MISUSE OF FERTILIZERS AND MANURES IN GREENHOUSES—Dr. Geo. E. Stone	751
AFTER AMOURNMENT	753
AN INTERESTING ANNIVERSARY—Portrait, C. L. Allen	753
NEWS OF THE CLUBS AND SOCIETIES:	
Tarytown Horticultural Society—Gardeners' and Florists' Club of Boston—American Carnation Society—St. Louis Horticultural Society—Rhododendron Exhibition at Boston—Meetings Next Week—Salem Cherry Fair—Pennsylvania Horticultural Society	754
CO-OPERATION BETWEEN WHOLESALER AND RETAILER—Arthur A. Niessen	755
OBITUARY—George F. Chandler, portrait	756
DURING RECESS:	
New York and New Jersey Association of Plant Growers—Florists' Club of Philadelphia	756
LIBRARY NOTES—C. Harman Payne	757
A CHEMICAL STUDY OF SOME GREENHOUSE SOILS—Henri D. Haskins	758
SEED TRADE	761
OF INTEREST TO RETAIL FLORISTS:	
Detroit—Steamer Departures	762
New Retail Flower Stores	763
FLOWER MARKET REPORTS:	
Boston, Buffalo, Chicago, Indianapolis, New York, Philadelphia	765
MISCELLANEOUS:	
Mildew on Killarney G. C. Watson	769
"Glory Be!"—G. C. W.	769
News Notes	756-757-761
Incorporated	767
Fungicides, Insecticides and Spraying	761
Catalogues Received	763
Business Changes	763
Personal	763
Greenhouses Building or Contemplated	773
List of Patents	773

conception formerly prevalent as to the difficulties attending the cultivation of this class of plants are now pretty well dissipated and it is generally understood that any grower intelligent enough to master the cultivation of any one of the other leading flower staples can achieve equal success in orchid growing.

Memorial Day business this year seems to have met with some hard jolts, brought about mainly by the unprecedented supply of garden and greenhouse product in many sections of the country.

Never since the holiday was instituted has there been such an overwhelming profusion of shrub and herbaceous bloom, all concentrated at one time, and we can hardly look for a repetition of the experience for many years to come. There seems to have been no trouble with the popular demand and the various reports as received indicate the distribution of a vastly larger quantity of flowers than ever before on any similar occasion, but so enormous was the crop that clearing out was an impossible task. Thus it was unavoidable that large stocks should go to waste under the circumstances. On reading that there were some exceptions to the general condition of overstock the question naturally presents itself as to why these needy people were not promptly supplied from the overburdened markets elsewhere. "And echo answers, why!" That such varying conditions should exist in these days of telephones and rapid transit seems to point to the urgent necessity of a better understanding and a greater facility of distribution as well as a closer heed to obvious market conditions and requirements by those who so ruthlessly spend their time in cutting and their money in shipping to wholesale centres material for which there is no outlet.

The paper on co-operation between the different interests in the plant and flower trade, by Mr. Niessen, which we publish in this issue treats on the same theme covered by Mr. Palmer's recent dissertation, under the more comprehensive text of "The Art of Selling," before the Gardeners' and Florists' Club of Boston, but from the opposite standpoint. Our editorial on salesmanship in issue of May 23, following upon Mr. Palmer's address, has elicited a number of comments from various sources, all agreeing that the subject is a very live one but none presenting any serious argument or purporting to suggest any remedy for the unsatisfactory phases which the flower trade has assumed in certain large distributing centres. While it is undoubtedly true that the general business depression, supplemented by the very unusual behavior of weather and crops, has been largely responsible for the predicament in which many growers and dealers have found themselves this spring, yet we are convinced that the time has now come for a remodeling of business methods which were good enough for the florist trade of a generation ago but antiquated and entirely unsuited to the needs of today. No business man can afford to remain oblivious to the improvement in merchandising methods continuously going on all around him. This touches directly upon what is the weakest feature in the whole structure of commercial floriculture. That it is the most disturbing element is evident to every one. The matter is not one to be passed upon lightly or disposed of off-hand by dogmatic assertion and we venture to affirm that there is no question that can be taken up by the florists' clubs and societies and dispassionately discussed, which more directly concerns the welfare of their members than this great problem—the disposal of the product.

During the past few weeks announcements of expected arrival of large consignments of orchids from tropical regions have been given wide publicity through the medium of the trade press. Not many years since, any dealer who would have undertaken any enterprise of the character and magnitude represented in any one of these shipments would have been simply foolish. The change in the relationship of these noble flowers to commercial floriculture which has come about in so short a time is most remarkable. A new and lucrative specialty business has been developed and the variety of material at the disposal of the flower lover or the decorator has in consequence, been marvelously enriched. As we have before remarked, the erroneous

Floriculture enriched

AFTER ADJOURNMENT.

If I were in the retail florist business and desirous of increasing my patronage during this month of weddings, graduations, steamer departures and glee, my first move this June morning would be to send to Bayersdorfer & Co. for a sample lot of those new and special flower baskets lately received. They are beauties and are sure to make an impression.

"Horticulture, an extremely interesting, high-grade publication issued in Boston, Mass.," is the way our esteemed contemporary, the "Long Island Agronomist," expresses its opinion of us. We appreciate the compliment, all the more so because the Long Island Agronomist is a practical little sheet with a mission and every line of its solid eight pages has a business purpose.

We are pleased to know that our British friends, having opened their hearts to the "winter flowering" or "perpetual" carnation as a florists' flower, are now beginning to look upon it with favor as a summer-blooming subject for the garden. This is a use to which it has not seriously been put in this country. We might return the compliment by giving some attention to the English dwarf border carnations, which are well worthy of a place in our American flower gardens.

Our correspondents, at all times ready to write about the weather on the slightest provocation, have regaled us with some very breezy accounts of how badly the uncertain elements treated them on Memorial Day. After all, James Whitcomb Riley's sentiments on this time-honored topic are about as sensible as anything ever advanced on the subject:

"It ain't no use to grumble and complain,
It's just as cheap and easy to rejoice;
When God sorts out the weather and sends rain,
Why, rain's my choice."

Our life-long friend, Thomas F. Galvin, of "Lawson pink" fame, has with characteristic enterprise been entertaining the local newspaper reporters and they, in turn, have been regaling the public with interesting data of his recent trip to Europe. Here are a few:

"From time to time prizes are produced over there, and one of these I have just succeeded in capturing. I have made four voyages with this end in view, and consider the victory worthy of the extended campaign. This prize is a new variety of carnation which I expect will make as great a sensation as did the famous Lawson pink a few years ago. The new one is pea green or Easter lavender in color, very delicate and beautiful. I have an option on 500 of the plants and shall grow them for three or four months longer near London and then go over to complete arrangements for transplanting them in this country."

"The Lawson pink of a few years ago, which I managed for the owner, cost him \$20,000, and yet he netted \$20,000 on his speculation in that little flower. We sold 650,000 of the cuttings in all parts of the world; at one time the Khedive of Egypt ordered 10,000 of them. My new variety is bound to eclipse it and the expense of securing the right to grow it is very little less than the earlier wonder cost Mr. Lawson."

"On this trip Mr. Galvin visited Amsterdam, Brussels, Paris and London, and purchased a quantity of palms, orchids and bay trees. These require so much space that he must charter two steamships to bring his cargo over."

AN INTERESTING ANNIVERSARY.

On June 12, C. L. Allen, one of the grand old men of horticulture, will celebrate his eightieth birthday anniversary at his home in Floral Park, N. Y. In a letter from the young old gentleman whom we are proud to have known as a friend for over thirty years, he tells us that "there is considerable satisfaction in growing old beautifully as I feel I am doing. Pneumonia tried hard recently to get the best of me, but it was no use. My strength is returning and my general



C. L. ALLEN

health has not been better, if as good, in the last twenty-five years." On his birthday Mr. Allen will read to his friends a paper which he has prepared, entitled "At Eighty." That it will be profoundly interesting and entertaining nobody who knows C. L. Allen's literary ability will question. All who read this will, we are sure, join us in wishing our friend an uninterrupted continuance of the good physical health and mental vigor which he now enjoys, for many, many years to come. May the sunset of his busy life be long, cloudless and serene.

MILDEW ON KILLARNEY.

I shall be glad to back up my statement as to the benefit of propagating Killarney from outdoor grown stock if Mr. Lonsdale really wants to know. If he only seeks to indulge in a controversy so as to interest people in the journal which is his new love, there is nothing doing. The statement that Mr. Lonsdale never had any mildew on any kind of propagation, old or young, indoor or outdoor, does not strengthen his case any. Let him go around the flower markets of his own city (Philadelphia) and he will find plenty of it! I simply suggested a method of prevention which has been tried and found good by competent people and in so doing followed the highest ideals of horticultural journalism. I stand ready and willing to help Mr. Lonsdale or any other florist as to any useful knowledge that comes under my observation, provided they ask for same in good faith and respectfully. To ask for a cure for mildew when one has not got any mildew shows that Mr. Lonsdale is hard up for a theme. Go to—my dear fellow! I'm not a lion—I'm a lion-slayer like yourself. Try Birnie; he looks something like a beast with horns—brownish gray in the dark of the woods; but you can't mistake me—I'm right at your elbow.

G. C. WATSON.

GLORY BE!

For some time there has been no spice in our horticultural journalism. When we look back on the glorious old gladiatorial days of fifteen years ago and think of the raciness and enthusiasm prevalent then and compare it with recent times we are compelled to admit that we have gone through a flat and commonplace few years. But things are brightening up some. There's the Koehler-Brown glory in HORTICULTURE over the rhododendron, the Birnie-Lonsdale illumination on the carnation situation; a hint of a fine educational campaign on salesmanship; and various other interesting things looming up. Rudd and McGorm and Stewart and Welch and Carmody and Crowe and Marquisee and many more good swordsmen are still above the sod, and if the game is worth while, can be counted on for a manly battle with their true names emblazoned on their shields and not masquerading in the cowardly garb of anonymity. Greeks bearing gifts and Trojan horses—not in their line. Let us all give thanks.

G. C. W.

As soon as the rhododendrons and garden azaleas have shed their flowers the seed pods should be promptly picked off. The plants will look much better and the strength which would have been wasted on the seed pods will be diverted to the young growths for next year's flowering.

"Like good wine your paper improves with age."—With best wishes,

W. H. CLARK,
New York, N. Y., May 23, 1908.

Enclosed please find money order One Dollar in payment of enclosed subscription bill. I appreciate your paper very much and wish you success.

VICTOR JOHANSEN,
California, May 11, 1908.

NEWS OF THE CLUBS AND SOCIETIES.

TARRYTOWN HORTICULTURAL SOCIETY.

The regular monthly meeting of this society was held on Friday evening, May 29, with President Angus in the chair. Three new members were elected.

For this meeting Mr. J. W. Lindsay had offered prizes for the best exhibits of cut flowers from shrubs and hardy herbaceous plants. Two fine lots were exhibited by John Woodcock, gardener to General McAlpin, Ossining, and Alexander Maitland, gardener to Mr. Carroll Dunham, Irvington, which were won in the order named.

The annual free June exhibition will be held in Music Hall, Tarrytown, on the afternoon and evening of June 12th, and we hope that every member will try to make an exhibit of flowers or plants and help to make this show a success. Schedules for this, also for the November exhibition, are ready, and will be sent to all interested. Apply to Secretary E. W. Neubrand, Tarrytown, N. Y.

Subject and exhibits for the next meeting will be shrubs and hardy perennials. L. A. MARTIN, Cor. Sec'y.

GARDENERS' AND FLORISTS' CLUB OF BOSTON.

At the next meeting of this club, which will be held on Tuesday evening, June 16, at 8 P. M., A. H. Kirkland, State Superintendent for Suppressing the Gypsy and Brown-tail Moths, will lecture on the various pests that menace shade trees. The lecture will be illustrated with stereopticon views. The new parasites and Japanese wasp, which have been imported to use in the warfare on the moths, will be shown and described.

AMERICAN CARNATION SOCIETY. Carnations Registered.

By Wa-no-ka Greenhouses, Barneveld, N. Y.—"Apple Blossom." Parentage, Enchantress on white seedling; color, white delicately blended pink; size of flower, average 3-4 inches through season; habit, rapid upright grower; all growth coming from the base, good producer and good keeper on long stiff stems.

By A. E. Boyce, Wellsville, N. Y.—Claribel Worth. Parentage Estelle and Maceo; color, scarlet crimson, very rich; size of flower, average 3-4 inches; at its best about Christmas. Good stems, non-bursting calyx, foliage rich blue; resistant to disease and insects.

ALBERT M. HERR.

Lancaster, Pa.

ST. LOUIS HORTICULTURAL SOCIETY.

Gentlemen:—

The St. Louis Horticultural Society wishes through these columns to express their appreciation and thanks to the various growers, wholesalers and retailers, for their liberal contribution of choice and fresh cut flowers donated to the "Floral Booth" at the Charity Carnival, held May 16, 1908.

Respectfully,

OTTO G. KOENIG, Sec'y.

RHODODENDRON EXHIBITION AT BOSTON.

The annual Rhododendron Exhibition of the Massachusetts Horticultural Society will be held at Horticultural Hall, Saturday and Sunday, June 6 and 7.

The season has been very favorable for rhododendrons and azaleas and it is expected that there will be a magnificent display of these flowers.

There will be also exhibits of orchids, wistaria, irises, tree peonies and other seasonable flowers as well as vegetables.

The exhibition, which is free to all, will be open Saturday from 12 to 6, and Sunday from 2 to 6 o'clock.

WM. P. RICH, Sec'y.

SALEM CHERRY FAIR.

The third annual meeting of the Salem Cherry Fair will be held at Salem, Oregon, July 9 and 10, 1908.

At the convention last July of the



Paris, France, June 1-15, International Rose Show.

Milwaukee, Wis., June 10-12, Convention of American Association of Nurserymen.

New York, N. Y., June 10, 11, American Rose Society and Horticultural Society of N. Y., rose show.

Glen Cove, N. Y., June 10, Nassau County Horticultural Society, exhibition.

Boston, Mass., June 13, Massachusetts Horticultural Society, peony show. June 20, 21, rose and strawberry show.

Pacific Coast Association of Nurserymen, a resolution was adopted saying that the Second Annual Salem Cherry Fair was the greatest and finest display of cherries known to history, and Salem was christened the "Cherry City of the World," by the association.

That Salem is entitled to the name will be admitted by everyone visiting the Cherry Fair this year, as it will be much larger and better than ever.

In addition to the cherries (for which a large number of silver cups are offered as premiums), there will be premiums for and displays of other fruits, as well as roses, sweet peas, Shasta daisies and other flowers. A large number of handsome diplomas will also be offered as premiums.

Cherry growers from all sections are urged to be present and bring fruit for exhibition. Premium list and rules will be furnished to any interested, and also published in the press. All fruit growers, nurserymen and florists are invited to be present. Those desiring to attend the Pacific Coast Association of Nurserymen can do so, as the two meetings are held early in July.

F. W. POWER.

Chairman Cherry Fair Committee.

PENNSYLVANIA HORTICULTURAL SOCIETY.

The annual June show of this society was held on the 2d inst. The chief exhibits consisted of outdoor roses, peonies and hardy perennials. The date was rather early for roses but just right for peonies and the latter showed up by far the best. The heavy rains of Saturday and the hot weather preceding were against a very high standard of excellence in either. Pepper, Penfield and Lippincott ranked in the order named for the best collection of six H. P. roses for the Huey prizes. No entries appeared in the hybrid teas worthy, except two lots of Pepper and Lippincott, which were nothing extra. These, and two lots of H. P.'s were for the Bodine prizes. The Mitchell prize for outdoor roses went to Penfield.

There was a very good showing of peonies notwithstanding all drawbacks. In the Bodine prizes, honors were divided between Penfield and Paul, Griscom coming in for a share. The Dreer prize also fell to Griscom, with a finely grown lot, for which Thos. A. Archfield, the gardener, deserves honorable mention. The George C. Watson prize for the best eight Japanese varieties went to Paul, for a very creditable lot of well grown flowers.

The keenest competition of all came in the collection of hardy perennials, twelve species, for the Dreer prize. Newbold had the best exhibit from a horticultural and educational standpoint with twenty-six distinct species but the Paul lot with twelve species filled the schedule requirement and so carried off first honors because they were much more showy and in better bloom. Pepper's collection was also very fine.

Julius Roehrs Co. exhibited their new white *Cattleya Mossiae* (unnamed as yet) which is shown in cover illustration of this paper. This is a white form with a faint blue tinge on the lip. It is larger than any other white *Mossiae* and experts declare it to be an extraordinary specimen for color, size and floriferousness. The eight-inch pan shown had five leads, four with three flowers and one with one. This variety appeared in an importation of common *Mossiae*, the exhibit and another piece in the possession of Mr. Clement Moore (acquired from Roehrs by purchase) being all that is known to exist at the present time.

Samuel Batchelor, gardener to Mr. Clement B. Newbold, exhibited a fine lot of gloxinias. We have seldom seen quite so magnificent a collection. The members of the Florists' Club were given an opportunity to view these at their monthly gathering and were much impressed.

It has been found necessary to change the dates of the meeting of the American Peony Society one day later, making them June 19 and 20.

A. H. FEWKES, Sec'y.

Co-operation Between Wholesaler and Retailer in Times of Overproduction

A PAPER READ BEFORE THE FLORISTS' CLUB OF PHILADELPHIA BY ARTHUR A. NIESSEN.

The title of this paper is "Co-operation Between Wholesaler and Retailer in Time of Overproduction." Why it has been added to the title "In Time of Overproduction" is more than I can understand. If we cannot work hand in hand when the market is about evenly balanced between supply and demand, we certainly cannot expect to do so when the commission man is at the mercy of the retailer. We always have had, and will have, at certain times of the season, a glut of some sort. This does not only apply to our trade, but to every other line as well. In our line it is due to unavoidable overproduction; in other lines, probably due to an overestimated demand. I would like to ask the retailers present, "Are you doing anything, or are you making any effort whatever to relieve the market of its overproduction?" Beyond finding fault with the manner in which the commission man is trying to meet this serious problem the majority are doing nothing.

A Problem Worthy of a Genius.

How to find a market for this overproduction is a problem worthy of a genius. It has been our experience that, although we offer flowers to the retailer at what would seem ridiculously low prices, he will not buy any more than he positively needs. The thought how he could handle this stock, and in some way increase his sales, never enters the minds of the majority of them. I am quite sure, if the retailer were situated the same as the commission man during a glut, that if he had to take the stock regardless of having an immediate outlet for it, he would find way and means to make it profitable for him to handle it. Necessity is the mother of invention, and it is wonderful what we can do when we must.

Progress is Slow.

It is very evident that to a certain degree the conditions of the market during a glut could be improved upon by co-operation, but in that direction progress seems extremely slow. The feeling towards the commission man by many of the retailers is decidedly antagonistic. It is indeed surprising that by many retailers the commission man is considered a necessary evil whose sole reason for existence is to oppress the retailer by extorting exorbitant prices and imposing all sorts of hardships. These retailers will without hesitation make the statement, that they will favor the grower who peddles his stock every time. The commission man is called upon only during a scarcity to supply that which the grower could not possibly supply. Coming to the commission man under such conditions, and being asked a fair price for the goods wanted, he assails the commission man for the seemingly unjust treatment and classes him with the pirates and daylight robbers. Just as soon as we can overcome the feeling of the retailer, as described above, towards the commis-

sion man, we are one point closer to co-operation.

The Street Outlet Indispensable.

We cannot dispose of our surplus to the five and ten cent stores; there is only one outlet left to us, and that is to put the flowers on the street. The street fakir by most retailers is looked upon as a demoralizer of the flower business. The commission man is solely blamed for his existence, but let me tell you, that for many of the growers who peddle their own stock, their last stopping place is the curb. He will take anything to relieve the load on his arm and will sell his ware at a price so low that the buyer is pledged to secrecy. He is ashamed to have the price known. Can you imagine what conditions would be if the growers were depending entirely on their own efforts to dispose of their products? Some of the fakirs undoubtedly have what may be termed "nerve." The fakir will buy five thousand carnations that are almost asleep, take them on the sunny side of Market street, in a temperature of about 90, and take what he calls a chance. How many retailers at the same price would take the same chance? I do not wish to be misunderstood, that I am here to speak for the fakir. There is not a commission man who would not gladly dispense with him, if there were any possible way of doing so. With few exceptions they are not a desirable lot.

Retail Stores Are Simply Sample Stores.

When you see the street fairly flooded with flowers you should always bear in mind the fact that the commission man has offered the stock to you first, that he has exhausted all the known science of salesmanship to induce you to buy them. Many retailers will advance the argument, that if there were no flowers on the street they could sell double the stock they are using. That is the very thing they should do, buy it and keep it off the street. "Give us the same chances you give the street fakir," is another time-worn saying. Let any of the retailers try it, and the results will startle them. Let them start out some morning and ask the commission man, "what will you take for the shelf," and if you mean business the shelf is yours. The tendency today is just in the opposite direction. Many of the retail stores may justly be called sample stores. They do not carry any stock, the commission man is carrying it for them. The demands are sometimes startling. Ten minutes after the goods are ordered they are supposed to be delivered. The excellent service brought about by live competition is sadly misused. In that direction co-operation would do much to overcome existing unpleasant conditions.

Harmony Between Grower and Commission Man.

The commission man has, after years of resistent efforts, gained the confidence of the growers. They are work-

ing hand in hand; the grower will consult the commission man about his crops for a coming season, he seeks his advice, and the trade has benefitted greatly by this "mutual interest" feeling existing between the grower and commission man. That feeling does not prevail as much between that retailers and commission man as it should.

Exorbitant Retail Prices.

There is one feature which in my estimation curtails the sale of flowers, and that is, many of the retailers do not keep their prices consistent with the prevailing wholesale prices. Beauties bought at \$1.50 per dozen are sold at three and four times the purchased price. For illustration I will cite an instance of a grower who entered a retail store and priced his own mignonette on sale there, and he was informed \$5.00 per dozen was the price. He then wondered why he was getting only 6.00 per hundred for it. To overcome a glut the retailers should aim to make large sales and small profits, instead of small sales and large profits. The ultimate results would be the same as far as profit is concerned, although a larger quantity of flowers has reached the consumer. There is too vast a difference in the price of flowers from the grower to the public. We should aim to reduce the cost of handling the stock from the time it leaves the greenhouses until it reaches the public. It seems some of the retail stores located on the main thoroughfares could dispose of large quantities of flowers by offering them at a reduced price. This they could do by eliminating all such expenses as deliveries of sales less than a certain amount, and by doing a cash business. This need not apply to all their trade, only to special sales, which may be called bargain for a certain day or time. The advertisement of bargains by the department stores is almost infallible bait to the public.

An Experiment.

A department store in a small town was selling carnations at twenty-five cents per dozen on Fridays and Saturdays. A retailer in the same town thought of meeting this price, and bought several thousand carnations to be put on sale the same days the department stores were offering theirs. The retailer did this, not expecting to make a profit on the sales, but principally to meet the price of the department store. Making inquiry, he was offered carnations at \$10.00 per thousand and he felt that he was being favored, but to put it more correctly, he was doing the commission man a great favor in buying the carnations. Selling them at twenty-five cents per dozen he disposed of as many as five thousand on Saturday. It is needless to say that beyond his expectation it turned out to be a very profitable business for him. There are ways and means of selling large quantities of flowers, and surely our retailers are energetic and enterprising enough to find them without having someone in

another line of business to show them how.

An Unwise Policy.

Ninety per cent of the public are lovers of flowers, and sixty per cent of them do not buy them because their means will not allow it. Why not, during a glut when flowers are cheap and plentiful, cater to the great masses, and give them all an opportunity to enjoy the beauties of nature? That would cultivate a public taste for flowers. Many prospective buyers hesitate to enter your store because they have only a small sum to spend. It is indeed a fact that by some retailers the twenty-five cent customer is considered a nuisance. That is a very sad mistake. Many retailers hesitate to reduce the prices of flowers for fear that they could not get a better price when the glut is over. They claim that their customers cannot understand why the prices of flowers should vary. I am sure we all know why the price of strawberries varies, and we know it simply because the public man has been educated along those lines. Not many of us can afford them in January, but there is a time in the year when we can buy them, no matter how humble our circumstances may be. The same can be said about flowers: during a glut sell them at a price so that they may find their way in every home. But don't let the street fakir do it for you.

Special Sales.

Another feature which is good for the business is to run special sales. There is hardly a time in the year when some stock is not more plentiful than others, which can be bought cheap. Advertise. How many florists do it? Some of the small local papers would be a good advertising medium in certain sections. A "special sale" will bring the crowd, the people will get into the habit of frequenting your store, you are advertising your business. In my estimation the flower business today has reached such large proportions that the advancement of the trade can only be accompanied by catering to the great masses, and not so much to the few.

True Co-operation.

Co-operation properly applied is indeed a fine thing; in fact, it is only practical when both or all parties concerned derive a benefit from their combined efforts. The definition of the word "co-operation," according to Webster, is "to operate jointly to the same end." The end in this case is mutual benefit, and without that there is no co-operation. Through co-operation is brought about a combined effort, which is much greater than the individual effort. Everyone concerned derives from such a combination, not a share of its strength and benefits, but all its force and good. If, in striving to advance our own position, we aim to advance that of the trade as well, we have true co-operation.

A man who toils solely for his own personal gain, who must make every transaction pay, regardless of the means to arrive at the point, is a menace to the trade in general. If each one of us would do a little something to better existing conditions, and do it with the feeling that the advancement of our profession is depending on our own individual effort, prompted by an

unselfish interest, we would soon arrive at a better understanding, which would reap its own reward.

There is only one way that a man can help his trade, and that is by having faith in it and confidence in those engaged in the same line of business. It is a terrible thing when we get so that we find fault with everything and everybody. We all know of some men who do this. "There is not an honest man anywhere." That is all wrong. Ours is a good profession to the man who is trying to better it. If we all had our shoulders to the wheel, lifting with all our might, there would be no time to see who else is lifting. It is all depending on individual effort to produce one great force. I would advocate co-operation, not only during the time for an over-production, but for every day in the year.

OBITUARY.

George F. Chandler.

George Frederick Chandler of South Lancaster, Mass., died on Memorial



GEORGE F. CHANDLER.

Day, May 30, 1908, at the advanced age of eighty-six years. Mr. Chandler was engaged in the florist business at the same location ever since the year 1842. For the past twenty years his son, F. L. Chandler, has been associated with him and will continue the business. Mr. Chandler was an upright and amiable gentleman, companionable, unassuming and well liked by all with whom he came in contact.

NEWS NOTES.

Henry L. Drummer, Bath, N. Y., filed a petition in bankruptcy on May 25; liabilities, \$1,110.32; assets, \$500.

The Fricker greenhouse, Poughkeepsie, N. Y., was sold at foreclosure sale May 23 and bought in by Conrad Gindra, the mortgagee.

Reports from Indianapolis are to the effect that this will undoubtedly prove to be the greatest spring season on record. The plantmen have been doing a thriving business the past two weeks with prices about the same as previous seasons.

During Recess

NEW YORK AND NEW JERSEY ASSOCIATION OF PLANT GROWERS.

The N. Y. & N. J. Association of Plant Growers held a well attended meeting at the Hotel St. Denis, New York city, on June 2. The committee appointed at the last meeting to arrange for an outing and which consisted of A. L. Miller, Herman C. Steinhoff, Herman Schoelzel and John Scott, made its report. The association will give its outing on June 25 at Terra Marine Inn, Huguenot Park, Staten Island, and the members will meet at the Staten Island Ferry, foot of Whitehall street, New York city, at 10:30 A. M. on that day and then proceed by boat, train and automobile to the place of the outing. The committee has made full arrangements for plenty to eat and drink, music, dancing, games, races, bowling and other spots and pastime. In order to evade the personal tax upon its capital, which has rapidly increased since its incorporation, the association has decided to furnish each of its members with tickets to the outing gratis. It is expected that all members with their families and friends will attend and thoroughly enjoy themselves.

FLORISTS' CLUB OF PHILADELPHIA.

After Arthur Niessen's paper on the relations that should exist between the wholesaler and retailer had been discussed by W. K. Harris, Jno. Westcott and other experts, business was rashed and an early adjournment called for the smoker. Many of us thought "smokers" were not germane to June; nevertheless there was a good turnout of members, and they seemed to heartily enjoy the varied program of story and dance provided by Messrs. William Graham, John Dunn, Jr., C. H. Grakelow and Frank Adelberger. The only club talent called on was Captain Lynch, who rendered "Ora pro Nobis" in masterly style and then spoiled everything by making a political speech. However, the crowd seemed to enjoy that, too. Bowling for convention team is now in order. Anyone who rolls fifteen games in June, and has an average 150 or over, is eligible to compete.

APPRAISERS' DECISIONS.

No. 19018.—Evergreen Seedlings—Nursery Stock.—Protests 272825, etc., of R. Ouwerkerk et al. (New York). Opinion by Waite, G. A.

The Board held that *Abies excelsa*, or Norway spruce, produced from seed, and *acubas* and *rhododendrons* were dutiable as evergreen seedlings under paragraph 252, tariff act of 1897, as claimed by the importers; also that azaleas were dutiable as nursery stock under the same paragraph. United States v. Ouwerkerk (T. D. 28353) followed.

I appreciate the good work your paper is doing and I would not be without it. Enclosed is my subscription. I am, Very truly yours,

JAMES J. SULLIVAN.

Newport, R. I., May 26, 1908.

Library Notes.

Judging from the inquiries that reach us concerning some of the books mentioned in this column, it is evident that there are readers of HORTICULTURE who appreciate the brief notices of the new European publications on gardening. We are therefore encouraged to continue our course in a path of horticultural knowledge and to disseminate information that might otherwise be difficult for those who are interested in gardening literature to obtain elsewhere.

The Journal of the Royal Horticultural Society, Part I of Vol. 33, has been issued; a bulky volume of more than 300 pages. The contents are too numerous to mention in detail, but among them are The True Darwinism by Prof. Henslow, Amateur and Horticultural Law by H. Morgan Veitch, Japanese Dwarf Trees by Albert Manmene (whose name is wrongly spelt "Maumerne", an unaccountable error to make considering he is one of the most eminent of modern French horticultural writers), Gesneraceae by Col Beddome, Natural Selection by C. T. Drewry, reports of trials at Wisley, etc. There are a few illustrations, some of them being reproductions of the original illustrations in M. Maumerne's work, Les Arbres Nains Japonais. Price \$1.85; free to members.

The Studio Year-Book of Decorative Art, 1908. We recently noticed the winter number of this fine art publication which dealt with the gardens of England. The present issue is not wholly devoted to gardening, but contains among other matter an important article entitled "On the Designing of Gardens" by Thomas H. Mawson, A. R. I. B. A., with illustrations of a very attractive character. The remainder of the work contains some charming examples of British country houses, German, French and Austrian architecture and decoration. Price \$1.25.

Color in the Flower Garden by Gertrude Jekyll. The most recent addition to the already well known Country Life Library and exhibiting all the high class features of typographical and artistic execution that characterizes these publications. Miss Jekyll is too well known an author to be summed up in a few lines and we must refer our readers to the book itself for the information given. There are plenty of fine process engravings illustrative of the text, besides plans for planting borders of decorative effect. The subject is dealt with in a very readable and instructive manner. Our only regret is that such a valuable addition to our garden library as this work undoubtedly is, does not contain a few illustrations in color. 148 pages, neatly bound and gilt lettered. Price \$3.00.

Cultivation of the Perpetual Flowering Carnation by C. H. Tandevin. This is a paper-covered booklet of 24 pages dealing in a concise manner

COLD STORAGE LILIES

COLD STORAGE LILIES, means that you can have Lilies all the year round. What are more useful, or give more character to the funeral piece than the Lily. We have, and can deliver at any time cold storage Lilies—and can refer you to hundreds that are growing them, why not you?

LILIUM LONGIFLORUM GIGANTEUM is the only longiflorum that gives satisfaction from cold storage—we offer them as follows:—**LILIUM LONGIFLORUM GIGANTEUM** (repacked) 6 to 8 inch bulbs, 400 in a case, \$8.50 per 100, \$75.00 per 1000, case of 400 for \$30.00. 7 to 9 inch bulbs, 300 in a case \$9.00 per 100, \$85.00 per 1000, \$25.50 per case of 300. 9 to 10 inch bulbs, 200 in a case, \$14.00 per 100, \$130.00 per 1000, \$26.00 per case of 200.

ARTHUR T. BODDINGTON, Seedsman, 342 WEST 14TH STREET, NEW YORK CITY

with a flower that is making rapid progress in this country. Price \$0.25.

Les Pois de Senteur par G. D. Clark. It is rare to find an English horticulturist writing a work in French, yet Mr. Clark in his enthusiasm for the sweet pea has accomplished the feat. His object is to promote its culture on the other side of the channel and in this little brochure of 32 pages he makes known to his French readers something of the flower which is but little grown in France as yet. A few illustrations are given. Price \$0.12.

How to Raise Daffodils from Seed by Cartwright and Goodwin. A neatly gotten-up little treatise, in paper wrappers, of about 60 pages. Early history. The first garden seedling, Miller on seed raising, Daffodils in the 17th century, Dean Herbert and his work, Edward Leeds and his work, the raiser of Horsfieldii, Wm. Backhouse and his work, the Rev. Geo. H. Englehart are subjects dealt with in the early part of the book. The remainder is then devoted to the purely practical part of daffodil raising in the various recognized sections. A little book that will be much sought after by the daffodil enthusiast.

Culture du Fraisier, et des Arbustes Fruitiers. Books on the strawberry, and especially French ones, are numerous. The most exhaustive in its day was undoubtedly the first, that by Duchesne published in 1766 and now very rare. Comte Lambertye was another author who published a very comprehensive treatise on this favorite fruit. The little book now before us runs into 233 pages and although as its main title implies it is on the strawberry chiefly, yet there are chapters dealing with the raspberry, the currant and the gooseberry. Besides the statistical, botanical, and cultural matter there is a good deal of attention paid to the commercial aspect of strawberry culture. A few illustrations of no particular merit are given. Price \$0.75.

National Dahlia Society. Supplement to Official Catalogue (H. H. Thomas, Sec., 68 Shakespeare Road, Hanwell, Middx). The Annual Supplement for 1908 to the Official Catalogue has been issued, a pamphlet of a dozen pages containing the latest novelties in Cactus, Show, Fancy, Pompon, Single and other selections. Free to members.

C. HARMAN PAYNE.

NEWS NOTES.

Wm. Elliott & Sons contemplate holding a big trade auction sale at their salesroom, 42 Vesey street, New York, on June 23. As this will be practically the "An revoir" sale for the season, Auctioneer Wm. J. is planning a pleasant surprise for his friends who attend on that day.

We have received pamphlets descriptive of the Perry pneumatic system from the United Pump & Power Co. of Chicago. The great advantages of the delivery of fresh water direct without the use of a tank or other storage supply are fully set forth and owners of greenhouses or grounds where abundant water of uniform temperature is a necessity will find this subject an interesting one.

INCORPORATED.

A. N. Pierson Company, Cromwell, Conn.; Andrew N., Wallace R. and Margaret G. Pierson; capital, \$200,000.

Mr. Ebbinge, of Ebbinge & Groos, Boskoop, Holland, was a visitor in Philadelphia this week. Mr. Ebbinge has a wide repute as an expert on new continental roses.

There are some
GOOD BARGAINS
listed in the
BUYERS' DIRECTORY,
Pages 768 to 772 this week.

VEGETABLE PLANTS

CABBAGE Wakefield, Early Flat Dutch, Early Allhead, Early Drumhead, and other early varieties. Surehead, Late Flat Dutch, Danish Round and Ballhead and other late varieties at 20c per 100, \$1.00 per 1,000, \$8.50 per 10,000.

TOMATO Stooce, Favorite, Paragon, etc., at 20c per 100, \$1.00 per 1,000, \$8.50 per 10,000 Dwarf Stone and Champion, June Pink and Early Jewell at 40c per 100, \$2.00 per 1,000.

CELERY White Plume, Giant Pascal, Gol. Heart and other varieties, 20c per 100, \$1.00 per 1,000, \$8.50 per 10,000.

BEEF Eclipse, Crosby and Egyptian, 25c per 100, \$1.25 per 1,000. Cash with order.

R. VINCENT JR. & SONS CO. WHITE MARSH, MD.

Asters 2000 First Class Plants from flats in collection for Florist. Cheap for cash or will exchange for small Ferns. 1000 Marguerite Carnation also, the same way.

Geo. H. Walker North Dighton
Florist : : : : : Mass.

A Chemical Study of Some Greenhouse Soils

During the spring of 1907 the writer's attention was called to a sample of cucumber soil that was sent to Dr. George E. Stone, of the Department of Vegetable Pathology of the Massachusetts Experiment Station. An examination made of the plants grown on this soil revealed the fact that no fungus disease was present* —the plants were very vigorous, but turned yellow prematurely and failed to develop a crop of fruit. Some of the leaves were spotted and resembled the Mosaic troubles sometimes seen on other plants. As nearly as we could find out the treatment of the soil had been about as follows:

Two years previous to the trouble the soil had been prepared by adding an equal amount of horse manure to pasture sod; more manure was added when the soil was transferred to the house and when the crop was put in, for underground heat, a trench of manure and chopped straw was used. An application of lime was made to the surface of the soil before putting out the crop and during the growing season considerable nitrate of soda was used. We were not able to ascertain the treatment of the soil during the two succeeding years, but it is quite probable that it was similar to that already described.

It was the belief of the pathologist, Dr. Stone, that the soil was over-fertilized and in order to throw some light on the subject, the writer undertook the chemical analysis of the soil.

In order that the results may be more intelligently interpreted by the average reader, I have reported them in comparison with the average chemical analysis of thirty-eight samples of barn yard manure.

	Average analysis of barn-yard manure.	
	Cucumber soil.	Per cent.
Moisture	36.72	73.38
Nitrogen	.55	.42
Organic matter	9.92
Potassium oxide	.48	.53
Sodium oxide	.43
Calcium oxide	1.12
Magnesium oxide	.47
Phosphoric acid	.51	.31

The above results show the cucumber soil to be considerably richer in nitrogen and phosphoric acid than are the better grades of farm yard manure.

A further study of the soil was made in order to ascertain how much of the plant food was soluble in water, as no doubt it is the soluble or available portion of the saline constituents that is responsible for the injurious effect upon the growing crop. The results of this study will be found reported in comparison with other analyses in the subsequent tables.

During the spring of 1908 a sample of cucumber soil was received by Dr. Stone from Orange, Mass., and another from Baldwinsville, Mass. A description of the behavior of the plants indicated that the difficulty might be due to an accumulation of soluble saline constituents; in other words, an excess of plant food. In

order to make a systematic study of the whole problem it became necessary to obtain data as to the average composition of a normal cucumber soil giving excellent results. The writer, therefore, obtained three such soils from well-known growers in the state and subjected them to the same treatment as was given the abnormal soils.

A given weight of the samples was leached out with a definite volume of hot water, the resulting solution was evaporated to dryness on a water bath and a chemical analysis was made of the saline residue.

In the table Sample No. 1 represents the Baldwinsville soil, No. 2 represents the Orange soil and No. 3 represents the soil analyzed in 1907. Nos. 4, 5 and 6 represent normal cucumber soils procured from well-known growers from various localities in Massachusetts. The results in the first table have been calculated to 100 parts of dry soil for the sake of comparison.

TABLE NO. 1.
Showing the per cent. of water soluble constituents in 100 parts of dry soil.

	Abnormal Soils.			Normal Soils.		
	No. 1	No. 2	No. 3	No. 4	No. 5	No. 6
Total solids	1.84	1.68	1.136	.456	.294	.19
Soluble nitrogen	.05	.012	.102	.025	.0055	.025
Soluble potash	.50	.41	.238	.085	.055	.026
Soluble phosphoric acid	.04	.045	.020	.017	.0007	.002
Soluble calcium oxide	.064	.045	.057	.047	.031	.03
Soluble sodium oxide	.22	.21	.192	.068	.06	.075
Soluble magnesium oxide	.054	.036	.031	.022	.009	.009
Soluble Sulphates (So ₃)	.069	.036	.050	.049	.029	.008

In this table note the large amount of total solids representing saline constituents and humus matter, also the high potash phosphoric acid, sodium oxide, magnesium oxide, and sulphates in the first three samples as compared with the normal soils Nos. 4, 5 and 6.

In table No. 2 the results have been expressed in pounds of the various constituents per acre and are based on the usual estimate that an acre of soil 1 ft. deep weighs 3,000,000 pounds. The results in this table were all calculated to normal soil moisture which averages about 20 per cent.

TABLE NO. 2.
Showing the amount of water soluble constituents in an acre of the several soils with average moisture conditions (20 per cent).

	Pounds per Acre.					
	Abnormal Soils.			Normal Soils.		
	No. 1	No. 2	No. 3	No. 4	No. 5	No. 6
Total solids	44,160	40,320	27,300	10,944	7,056	4,500
Soluble nitrogen	1,200	288	2,457	600	132	600
Soluble potash	12,000	9,840	5,733	2,040	1,320	624
Soluble phosphoric acid	960	1,080	491	408	168	48
Soluble calcium oxide	1,536	1,080	1,365	1,128	744	720
Soluble sodium oxide	5,280	5,040	4,641	1,632	1,440	1,800
Soluble magnesium oxide	1,296	864	737	528	216	216
Soluble sulphates (So ₃)	1,636	864	1,201	1,296	696	192

In the above table observe the excessive amount of total solids, and the various constituents in the first three soils as compared with the last three soils. I would also call special attention to the composition of soil No. 6 which is a comparatively new soil, it having been used for growing cucumbers only two or three seasons, but with very flattering results. Note the comparatively small amount of total solids and soluble saline constituents.

To bring this matter out more strikingly, I have prepared a table showing the average composition of the three abnormal soils as compared with the three normal soils.

TABLE NO. 3.

Showing an average of the composition of the soluble constituents in the three abnormal soils as compared with the three normal soils. Results expressed in pounds per acre.

	Ab-normal No. 1	Normal No. 2
Total solids	37,260	7,520
Soluble nitrogen	1,315	444
Soluble potassium oxide	9,191	1,328
Soluble phosphoric acid	843	208
Soluble calcium oxide	1,327	864
Soluble sodium oxide	4,987	1,624
Soluble magnesium oxide	966	320
Soluble sulphates (So ₃)	1,240	727

To express in a more intelligent manner to the average reader the serious excess of water soluble plant food as shown in the abnormal column of table No. 3, a calculation has

been made which shows that it would take 41.4 tons of nitrate of soda to furnish the nitrogen; 91.4 tons of high-grade sulphate of potash analyzing 50 per cent. K₂O to furnish the potash; 2.34 tons of acid phosphate to furnish the phosphoric acid and 3.4 tons of burned lime to furnish the calcium oxide. Or, to express the results in terms of a mixed fertilizer it would require an application of 17 tons of mixed fertilizer made up of the highest grade of material and analyzing about 4 per cent nitrogen, 27 per cent actual potash and 21.2 per cent phosphoric acid.

When we consider that the above

figures only represent that portion of plant food present in the soil which is soluble in water and that the total amount of plant food in the several abnormal soils runs from 8 to 40 per cent higher in many cases, we begin to realize what an enormous accumulation of plant food has taken place and we only wonder that the plant can make a start in growth. It may be interesting in this connection to know that the results of some investigations on tobacco soils that the writer has

*For a more extended pathological description of the trouble see article by Dr. G. E. Stone, in this issue.

CANNAS

**STARTED PLANTS in 3½ and 4-in. POTS
READY FOR IMMEDIATE PLANTING**

Mme. Nardy, Mile. Berat, Robert Christie, Golden King, Pennsylvania, L. Patry, Florence Vaughan, Pandora, Austria, Rohallion, Pierson's Premier, Queen Charlotte, Frederick Benary, etc.

EXTRA STRONG PLANTS, \$6.00 PER 100

VINCAS AND ENGLISH IVIES

Extra fine plants in 3½ and 4 inch pots, for vases, tubs, etc. \$8.00 per 100; extra size, \$10.00 per 100.

HYDRANGEA OTAKSA

LARGE PLANTS IN TUBS AND HALF-BARRELS FOR JULY AND AUGUST FLOWERING
We make a specialty of these, and have a magnificent lot of large plants, which we can supply in any quantity—Large plants in tubs, \$2.00 and \$3.00 each. Extra large plants in half-barrels, \$5.00 and \$7.50 each.

- NASTURTIUMS.** Bushy plants, 3 inch pots, \$6.00 per 100.
- SALVIAS, Bon Fire.** 2½ inch pots, \$4.00 per 100.
- AGERATUM.** 2½ inch pots, \$3.00 per 100.
- MOON FLOWERS.** 2½ inch pots, \$6.00 per 100.
- COLEUS, assorted.** 2½ inch pots, \$3.00 per 100.
- ALYSSUM, Tom Thumb.** 2½ inch pots, \$3.00 per 100.
- CROTONS, for bedding.** Extra strong plants, 3½ inch pots, \$25.00 per 100; 5 inch pots, \$50.00 per 100.
- ACALYPHA MOSAICA.** Extra choice, for bedding. 2½ inch pots, \$6.00 per 100.
- PANDANUS VEITCHII.** 5 inch pots, \$9.00 per dozen; 6 inch pots, \$12.00 per dozen; large plants, \$2.00 to \$3.50 each, according to size.
- FICUS ELASTICA.** 5 inch pots, \$4.00 per doz; 6 inch pots, \$6.00 per doz.

- ORACENA FRAGRANS.** Extra large plants, 6 inch pots, 3 feet high, \$12.00 per dozen.
- FERNS, assorted.** Extra heavy plants, 2¼ inch pots, \$3.00 per 100; 3½ inch pots, extra heavy, \$10.00 per 100.
- NEPHROLEPIS PIERSONI ELEGANTISSIMA.** 2¼ inch pots, \$6.00 per 100; 3½ inch pots, \$15.00 per 100; 6 inch pots, \$3.00 per dozen; 8 inch pots, \$12.00 per dozen.
- BOXWOOD, Pyramids.** Extra fine plants, \$2.00 and \$3.00 each.
- PANSIES, ENGLISH DAISIES, and FORGET-ME-NOTS.** \$2.00 per 100.
- CARNATIONS, Winsor and White Enchantress.** We can supply these in quantity, ready for immediate planting. Strong established plants from 2¼ inch pots, \$7.50 per 100; \$60.00 per 1000.

F. R. PIERSON CO., Tarrytown-on-Hudson, New York

ROSES

100 of the best Hardy sorts.

HYBRID PERPETUALS

Finest English Grown Plants

Dozen, \$3.50; 100 \$25.00

EVERBLOOMING HYBRID TEAS

Bloom from Midsummer until frost.

Dozen \$5.00; 100, \$35.00

Hardy Climbing Roses

All the leading sorts.

Catalogue Free on Application.

R. & J. FARQUHAR & CO.

6 and 7 So. Market Street,
Boston, Mass.

ROSES

Strong, Clean Stock.
Grafted, Killarney, Richmond, Brides and Maids. \$12.00 per 100, \$110.00 per 1000. Own Roots, Brides, Maids, Gates, Ivory, Perle, Killarney and Richmond. \$6.00 per 100, \$55 per 1000. All from 3½ in. pots.
P. R. QUINLAN, Syracuse, N. Y.

DAHLIAS.

Now is the time to place your order for bulbs which will insure you getting named varieties in any quantity; prompt delivery.

DAVID HERBERT & SON,

Successors to L. K. Peacock, Inc.
ATCO, N.J.

ROOTED CHRYSANTHEMUM CUTTINGS

Glory of the Pacific, Polly Rose, Ada Byron, Kalb, Halliday, Harry Sinclair Bonaffon, \$1.50 per 100.

Fair Maid Carnation Cuttings, \$1.00 per 100; \$3.00 per 1000.

H. F. Littlefield, 552 Main St., WORCESTER, MASS.

MONEY MAKERS

CHRYSANTHEMUMS—White and Yellow Bonaffon, Ivory, Rooted Cuttings, \$10.00 per 1000.

Nutt, Poitevine, Ricard and other BEST Geraniums, 4-in. stock, \$7.00 per 100.

H. L. CAMERON
North Cambridge, - - Mass.

CHRYSANTHEMUMS

In all standard varieties and colors now ready for planting from 2¼ pots, \$3.00 per 100, \$20.00 per 1000.

CHARLES H. TOTTY, Madison, N. J.

FERNS

Assorted for JARDINIERES

Strong, healthy plants 2¼ inch pots, \$3.00 per 100 \$25.00 per 1000; 500 at 1000 rate. 3 inch, \$6.00 per 100.

FRANK N. ESKESEN, MADISON, N. J.

NEPHROLEPIS SCOTTII

in the following sizes, extra good value

25c., 50c., 75c., and \$1
Grand Specimen Plants at \$3, \$4, \$5, \$6.
JOHN SCOTT
Rutland Road and E. 45th St.
Tel. 2890 Bedford BROOKLYN, N. Y.

NEP. WHITMANI

2¼ in., \$5.00 per 100

NEP. WHITMANI

3½ in., \$25.00 per 100

BOSTON FERNS

2¼ in., \$3.00 per 100

H. H. BARROWS & SON Whitman, Mass.

ORCHIDS

Largest Importers, Exporters, Growers and Hybridists in the World

Sander, St. Albans, England and 295 Broadway, Room 1 NEW YORK CITY

IMPORTED ORCHIDS

Arrived in Superb Condition

Vanda coerulea, Cattleya Trianae, Cattleya gigas Sanderiana, Cattleya Schroederiae, Oncidium varicosum.

JULIUS ROEHR'S CO., Rutherford, N. J.

ORCHIDS for Spring Delivery

NEW IMPORTATIONS

Cattleyas, Laelias, Oncidiums, etc.

WRITE FOR PRICES

Now is the time to Pot Orchids. Best Quality of Peat, Moss and Baskets on hand.

JOSEPH A. MANDA, 191 Valley Road, WEST ORANGE, N. J.

ORCHIDS

arrived in superb condition

Cattleya Trianae, C. labiata, C. Mossiae, Oncidium Varicosum, Vanda Coerulea, Dendrobium Formosum and D. Dalhousieanum.

LAGER & HURRELL, Summit, N. J.

ORCHIDS

Arrived in fine condition, C. Mossiae, C. Percivaliana, C. Trianae, C. labiata, C. gigas Sanderiana, C. Harris-onia, C. Schroederiae, C. citrina Den. Formosum giganteum, D. Wardianum, D. Findleyanum, Oncidium Varicosum Rogersii, O. Tigrinum, O. Ornithobrychum, Laelia anceps. To arrive shortly, Vanda Coerulea, Cattleya Gaspelliana, C. Mendellii, Phalaenopsis Amabilis, P. Schilleriana.

CARRILLO & BALDWIN, Secaucus, N. J.

ORCHIDS

We advise the Growers and Private Places that our Importations will now begin to arrive and we will have the following: C. gigas, C. gigas Sanderiana, C. Mendellii, C. Schroederiae, C. Trianae, C. Gaskelliana, C. Percivaliana, C. aurea, Miltonia vexillaria, C. Mossiae, C. speciosissima, C. labiata and others. We guarantee that our plants will be extra fine with no disease or Cattleya fly and will quote the Lowest Prices in America.

ORDONEZ BROS., MADISON, N. J.

Prices Quoted in these Columns are for Dealers Only. When Writing to Advertisers Please Mention HORTICULTURE.

<p>Tobacco Paper IS THE STRONGEST, BEST PACKED, EASIEST APPLIED.</p> <p>24 sheets.....\$ 0.75 144 sheets..... 3.50 288 sheets..... 6.50 1728 sheets..... 35.10</p>	<h1 style="margin: 0;">"NICO-FUME"</h1> <p style="margin: 0;">Furnishes the Most Nicotine for the Money!</p> <p style="margin: 0;">... Manufactured by ... THE KENTUCKY TOBACCO PRODUCT CO., Louisville, Ky.</p>	<p>LIQUID OVER 40% NICOTINE</p> <p>By far the CHEAPEST.</p> <p>JUST NOTE PRICES!</p> <p>Pint.....\$ 1.50 ½ Gallon..... 5.50 Gallon..... 10.50 5 Gallons..... 47.25</p>
--	--	--

made have indicated that the growth of young tobacco plants has been stopped and the plants seriously injured by about one-eighth as much soluble salines as is shown in the above analyses.

The writer is not prepared to say how large an accumulation of soluble saline constituents may take place before a cucumber crop will be injuriously affected. The results of data at hand, however, would indicate that a relatively wide latitude may be allowed on at least some of the constituents. It is my belief that the combined effect of the *total soluble mineral constituents* in the soil is responsible for the injurious effect on growing plants rather than an accumulation of any one of the soluble elements; although a continued and excessive application of any one of the essential elements of plant food will produce characteristic abnormal conditions.

There seem to be reasonable grounds for the belief that many cucumber growers are using a too liberal amount of horse manure for general practice, especially when we take into consideration the relatively large amount of this material that is sometimes used in trenches to furnish underground heat to the soil. As this manure decomposes under the influence of heat and moisture the mineral constituents become soluble, and, by means of water which is added from time to time to the growing crop, are diffused throughout the soil. Much soluble plant food is added to the soil in this manner that is not taken into consideration by the average grower.

The above investigations bring out one fact of unusual interest, namely, the large amount of water soluble potash as compared with the total potash content of the soil. The total potash present in No. 3 soil on the basis of 100 parts of dry matter was .76 per cent. of

which .21 per cent. was present in the water soluble form. The writer has found the same condition to exist in case of tobacco soils which have been heavily fertilized for a term of years and has found as high as 511 lbs. of water soluble potash per acre in 8 inches of the surface soil. The writer is aware that these facts are not in accordance with the teachings of German scientists and other agricultural investigators who affirm that potash does not remain in solution for any great length of time but is soon fixed as basic compounds in the soil only to be liberated gradually by chemical action continually taking place during the growing season.

The phosphoric acid found present in the water solutions of the soils is another curious fact and is quite the exception to the general rule. The writer has found only two samples of tobacco soil which showed the presence of water soluble phosphoric acid.

The solution and diffusion of the soluble nitrogen compounds is what one might expect of this illusive element of plant food. The presence of the comparatively large amount of this element in the soil solutions was therefore not unexpected.

As a preventive measure might be recommended the more judicious use of manure and fertilizer. Upon the first indication of an accumulation of soluble saline constituents or over-feeding the soil should be leached out, preferably with hot water, as soon as the crop has been removed. The leaching may be accomplished with cold water and, in case of some crops, without their removal from the soil. In case a crop is suffering from an excessive application of manure and it is not advisable to leach out the soil, the best remedy would be to apply two or three inches of loam to the surface of the beds. This promotes the formation of new roots and has been known to save the crop.

In case the benches have been arranged for sub-irrigation, the leaching may be accomplished by allowing the drainage waters to pass off through the sub-irrigation pipes, arrangements being made so that the water may run off freely. Where it is not possible to leach the soil it should be replaced with new soil; or it might answer to remove one-half of the old soil and carefully and thoroughly mix an equal volume of new soil with the remainder.

The old soil removed from the benches, as well as the solution resulting from leaching the same, may be used as a fertilizer to good advantage on out-of-door crops and would probably not prove inferior to the average farm yard manure.

HENRI D. HASKINS.

DON'T EXPERIMENT

USE

TO-BAK-INE

and your stock will be free from insects, clean, and the blooms will not be discolored.

Send for full information of

W. W. RAWSON & CO.,
5 Union St., Boston.

STUMPP & WALTER CO.,
50 Barclay St., New York.

HENRY F. MICHELL & CO.,
1018 Market St., Philadelphia.

E. H. HUNT, Gen'l Agent,
76-78 Wabash Ave., Chicago.

STERILIZED

Sheep Manure to help out backward vegetation, 100 lbs. \$1.50.

W.M. ELLIOTT & SONS
42 Vesey Street, New York



Cattle Manure
In Bags Shredded or Pulverized

Best and safest manure for florists and greenhouse use, absolutely pure, no waste, no danger. Write for circulars and prices.

The Pulverized Manure Co.,
31 Union Stock Yards, Chicago



The Best
Bug Killer and
Bloom Saver

For PROOF
Write to

P. R. Palethorpe Co.
OWENSBORO, KY.



JAGER
SPRAYERS

are money savers because they enable you to do the work right, with little labor and without wasting solution. We make an outfit for every need, from large Power Sprayers to small Hand Sprayers—each the best of its kind. **Special Sprayer Book Free**, illustrating and describing our complete line. Investigation pays.
Chas. J. Jager Co., 251-3 Franklin St., Boston, Mass.
Branch: 33 Canal St., Providence, R. I.

Seed Trade

The McKay Seed Co. has opened at Jackson, Miss.

John A. Kepner has recently added seed departments to his two stores at Harrisburg and the store at Steelton, Pa.

One of the leading seed-growing concerns in Connecticut reports that the volume of its business this season has established a new high record, and the condition is attributed to the industrial depression. It is explained that, for purposes of economy, a great many householders are this year cultivating small gardens and are raising their own vegetables. This policy has created a great demand for seeds and has imparted unusual prosperity to the seed-growing industry hereabouts.—Boston Transcript.

FUNGICIDES, INSECTICIDES AND SPRAYING.

The Massachusetts Agricultural Experiment Station has recently issued Bulletin No. 123, Fungicides, Insecticides and Spraying Directions, giving formulas for the preparation of fungicides and insecticides with directions for preventing and controlling fungous diseases and insects. Serious injury from these causes is now so common that the plain directions given in this bulletin should prove of much value. This bulletin discusses not only the common crops of the field and garden, but shade trees as well. It includes also a brief article on the methods to be adopted for the destruction of weeds in mowings, cultivated fields, tennis courts and walks. It will be sent free to applicants, who should address Massachusetts Agricultural Experiment Station, Amherst, Mass.

CATALOGUES RECEIVED.

W. Atlee Burpee & Co., Philadelphia, Pa.—Wholesale prices on turnip seed.

S. L. Allen & Co., Philadelphia, Pa.—Descriptive price list of Planet, Jr., farm and garden implements.

SOW NOW

PRIMULA OBCONICA GRANDIFLORA

Kermesina, Red	Tr. Pkt.	40c
Rosea, Pink	"	30c
Alba, White	"	30c
Hybrida, Mixed	"	30c

MICHELL 1018 MARKET ST. PHILA. PA.

Winter-flowering SWEET PEA SEED

All Colors

New crop ready in August next. Ask for list.

A. C. ZVOLANEK

ORIGINATOR.

BOUND BROOK, N. J.

SWEET PEAS

For THANKSGIVING and CHRISTMAS

BODDINGTON'S CHRISTMAS WHITE.....	10c	40c	60c	\$1.00
" " PINK.....	10c	40c	60c	1.00
" SNOWBIRD, the earliest forcing white ...	15c	75c	1.25	2.00

ALL THE ABOVE MAILED FREE

ARTHUR T. BODDINGTON, Seedsman
349 West 14th Street, - NEW YORK CITY

ASTER GROWERS ATTENTION:—

Our Seed is All Sold. If you failed to get some it is your loss. However:— Get a Competition Card Now, Enter your name as an Aster Grower of America and win part of our \$250.00 offered in prizes. Entry free. All information gladly given. No cost to you except to prepay the express charges on flowers sent in competition.

Altimo Culture Co., Garfield, Ohio.

Thorburn's Seeds

Seeds of ASPARAGUS PLUMOSUS NANUS, \$2.00 per 1000.

Seeds of ASPARAGUS PLUMOSUS ROBUSTUS, \$2.00 per 1000.

COLD STORAGE LILY OF THE VALLEY PIPS

JAPAN LILIES, JAPAN IRIS

For prices, state quantities required.

J. M. THORBURN & CO.
33 Barclay St., through to 38 Park Place
NEW YORK

Best Quality Fall Bulbs

It is to your advantage to place your order early. Send us a list of your wants and we will quote you rock-bottom prices. Copy of our Florists' Bulb Catalogue will be sent upon request. Catalogues now ready.

VICK'S SUPERB PANSY SEED

All the best varieties in separate colors

VICK'S SUPERB MIXTURE

the best strain from all the leading named sorts

1-8 oz. 75c. 1-4 oz. \$1.50 Ounce \$5.00

JAMES VICK'S SONS, Rochester, N. Y.

PRIMULA, FRINGED SINENSIS

This seed has been grown for us by a specialist in the culture of Primula, and he has produced plants of sturdy growth, large, thick flowers beautifully fringed and carried on erect stems well above the foliage; unexcelled in size, substance and beautiful colors.

Giant Perfection Strain, Finest Mixed, 1-64 oz., \$1.00
Pure White, Brilliant Pink, Blue, Chiswick Red, and
Crimson, 1-64 oz., \$1.00.

H. E. FISKE SEED CO.
13 Faneuil Hall Sq. - BOSTON, MASS.

CAULIFLOWERS CABBAGE SEED

HJALMAR HARTMANN & CO.,
12 Stormgade,
COPENHAGEN, DENMARK.

SOW NOW MY STRAIN OF

Hardy Garden Carnations as: 6 Tr. Tr. Pkt. Pkt.

Special Mixture of extra double flowers.....	\$2.50	.30
Dwarf Scarlet Grenadin.....	2.00	.20
Early Dwarf Vienna, finest mixed.....	1.00	.20
New Early White Vienna, fine for cut.....	1.50	.20
New Early Dwarf Hardy Garden Pinks, in splendid colors, mixed.....	4.00	.50

O. V. ZANGEN Seedsman Hoboken N. J.

JUST ARRIVED LARGE SHIPMENT OF High-Grade SCOTCH SOOT.

We have the Stott Double Nozzle
THOMAS J. GREY CO.
32 & 33 So. Market St., BOSTON

BRIDGEMAN'S SEED WAREHOUSE RICKARDS BROS. Props.

37 East 19th St., - NEW YORK CITY

BRASLAN SEED GROWERS CO.,

GROWERS FOR THE

WHOLESALE TRADE ONLY

SAN JOSE, - CALIFORNIA

BRECK'S SEEDS

For Farmer, Market Gardener and Florist

New Crop High Grade

Catalogues mailed free on application

Joseph Breck & Sons Corp.
47-54 NO. MARKET ST., BOSTON, MASS.

XXX SEEDS

CHINESE PRIMROSE. Finest grown, varieties mixed; 500 seeds, \$1; half pkt., 50c.

CINERARIA. Finest large-flowering dwarf, mixed; 1000 seeds, 50c.

GIANT PANSY. Best large-flowering, mixed, critically selected; 5000 seeds, \$1; half pkt., 50c. Cash.

JOHN F. RUPP, SHIREPLANTSTOWN, PA.
The Home of Primroses.

Burpee's Seeds PHILADELPHIA

Blue List of Wholesale Prices mailed only to those who plant for profit.

**JOHN BREITMEYER'S
SONS**
Cor. Miami and Gratiot Aves.
DETROIT, MICH.
**Artistic Designs . . .
High Grade Cut Blooms**
We cover all Michigan points and good
sections of Ohio, Indiana and Canada

**William J. Smyth
FLORIST**
Cor. Michigan Ave. and 31st St., CHICAGO
We ship to all points in Illinois and Iowa.
Phones: Douglas 744, Douglas 523, Douglas 740

M. C. and J. E. HAUSWIRTH
232 Michigan Ave.
CHICAGO
AUDITORIUM ANNEX Tel. Harrison 585

**SAMUEL MURRAY
Florist**
Coates House Conservatory
1017 BROADWAY, KANSAS CITY, MO
Both 'Phones 2670 Mafa

**FRED C. WEBER
FLORIST**
4326-28 ST. LOUIS, MO.
OLIVE STREET Established 1873
Long Distance Phone Bell Lindell 676



WASHINGTON,
D. C.
GUDE'S
GUDE BROS CO
FLORISTS
1214 F ST NW
WASHINGTON D.C.

The Far-Famed Flowers of
TORONTO
Delivered on mail or telegraph order for
any occasion, in any part of the Dominion.
JOHN H. DUNLOP,
96 Yonge St., Toronto, Ont.

The Park Floral Co.
J. A. VALENTINE
Pres.
DENVER, COLORADO

**WILLIAM L. ROCK
FLOWER CO.**
KANSAS CITY, MO.
will carefully execute orders for Kansas City
and any town in Missouri or Kansas.

Of Interest to Retail Florists

DETROIT Reports on hand from many retailers show very satisfactory business conditions for Memorial Day, and many retailers point delightedly to more and better sales this year than in former years. While this in itself is gratifying we find therein another point much more important, and this is the repeated proof that our product has become a staple and necessity of life instead of

STEAMER DEPARTURES

Allan.	
Corsican, Montreal-Liverpool.....	June 11
Virginian, Montreal-Liverpool.....	June 19
Anchor.	
Furnessia, New York-Glasgow....	June 13
California, New York-Glasgow....	June 20
American.	
New York, New York-Southamp- ton.....	June 13
St. Louis, New York-Southamp- ton.....	June 20
Atlantic Transport.	
Minnehaha, New York-London....	June 13
Minneapolis, New York-London....	June 20
Canadian Pacific.	
Empress of India, Montreal Liver- pool.....	June 12
Empress of India, Montreal Liver- pool.....	June 20
Cunard.	
Ivernia, Boston-Liverpool.....	June 16
Caronia, New York-Liverpool.....	June 13
Lusitania, New York-Liverpool....	June 17
Slavonia, New York-Mediterranean	June 15
North German Lloyd.	
Kronprinz Wilhelm, New York- Bremen.....	June 16
Frederick der Grosse, New York- Bremen.....	June 20
Red Star.	
Vaterland, New York-Antwerp....	June 13
Zeeland, New York-Antwerp.....	June 20
White Star.	
Teutonic, New York-Southampton	June 10
Adriatic, New York-Southampton	June 17
Baltic, New York-Liverpool.....	June 17
Cedric, New York-Liverpool.....	June 18
Cretic, New York-Mediterranean..	June 20
Cymric, Boston-Liverpool.....	June 20

being a luxury as it was in the past. As a nation advances in prosperity and many articles of luxury become articles of necessity, the producer of such articles finds that the least commercial disturbance causes a decided falling off in his cash receipts. We may have felt such a falling off during the recent money stringency, and if our receipts this year are smaller than last year it may have been caused by just such circumstances, but, nevertheless, the increase in trade for a celebration which in these days of waning idealism has become more of a day for excursions and ball games is a true sign that we are fully reaping the bene-

Chicago. Established in 1857



1657-1659 Buckingham Place
L. O. Phone 558 Lake View. Send us your retail orders.
We have the best facilities in the city.

ALEX. McCONNELL
571 FIFTH AVENUE
NEW YORK CITY
Telegraphic orders forwarded to any part of the United States, Canada, and all principal cities of Europe. Orders transferred or intrusted by the trade to our selection for delivery on steamships or elsewhere receive special attention.
Telephone Calls, 487 and 488 38th St.
Cable Address, ALEXCONNELL

DAVID CLARKE'S SONS
Deliver orders from any part of the country to
New York City
Or OUT-GOING STEAMERS
Write or telegraph
2139-2141 Broadway, New York
Telephone 1552-1553 Columbus

YOUNG & NUGENT
42 West 28 St., NEW YORK
"FLOWERS BY TELEGRAPH"

Flower Deliveries
In Brooklyn and other Long Island Points
New York City, New Jersey, etc. At Theatres,
Hotels, Steamers or Residences.
WILSON
Fulton St. and Greene Ave., Brooklyn, N.Y.

ALBANY, N. Y.
EYRES
Flowers or Design Work
DELIVERED IN ALBANY AND VICINITY
ON TELEGRAPHIC ORDER.
11 NORTH PEARL ST., ALBANY, N. Y.

YALE Orders for flower
deliveries to Yale
College and all
other Connecticut
points carefully filled and delivered by
J. N. CHAMPION & COMPANY
1026 CHAPEL STREET NEW HAVEN, CONN.

JACOB SCHULZ, 644 Fourth Ave.,
LOUISVILLE, KY.
Cut Flowers of BEST QUALITY in season
delivered promptly to any address.
Write, Telegraph or Telephone.
Cumberland and Home Phones 223 and 984

ATLANTA FLORAL CO.
41 Peachtree Street, ATLANTA, GEORGIA.

In ordering goods please add "I saw
it in HORTICULTURE."

fit of our labors in the past and are coming to be recognized as distributors of goods which are a necessity in life as it is lived today.

NEW RETAIL FLOWER STORES.

- Elmhurst Floral Co., Oakland, Calif.
- Robert Zepnick, 147 Lincoln Ave., Milwaukee, Wis.
- W. A. Summers, 1602 Pennsylvania Ave., Baltimore, Md.
- F. T. Ewert, 6321 Cottage Grove Ave., Chicago.
- J. B. Opitz, 6643 Cottage Grove Ave., Chicago; H. A. Muir, manager.
- Young the Florist, Broad St., Providence, R. I.

BUSINESS CHANGES.

Roepke & Rieman have purchased the Stratford place of the Smith & Young Co., Indianapolis, Ind.

The plant of the Terre Haute Rose & Carnation Co., Terre Haute, Ind., has been leased by Alex. Millar, Jr.

H. N. Wild has purchased the interest of his brother Frank in the Wild Bros. Nursery Co., Sarcoxie, Mo., and will retain the present name of the concern.

A. E. Boyce, Wellsville, N. Y., has disposed of his general stock to Mrs. D. S. McEwen, who will continue the business. Mr. Boyce will devote his time to his new carnation, Claribel Worth.

The Racine Floral Company has purchased the Fidler & Adams greenhouses, Racine, Wis., and after closing out the stock on hand will make extensive improvements and introduce modern equipments. Mrs. E. Miller, who has for several years had charge of the decorations at Hotel Pfister, Milwaukee, will be associated with the company.

The Denison (Texas) Civic Improvement League has offered quite a list of prizes to the school children for best results obtained through the planting of flower seeds distributed through the public schools in the spring for planting in the home yards of Denison. More than eight thousand packets of seed were distributed by the League this year and many home yards have been greatly beautified through the efforts of the children, who have also gained the interest and assistance of their elders.

A. E. Graves has started in the market gardening business at Gardner, Mass.

Wired Toothpicks

Manufactured by

W. J. COWEE, BERLIN, N. Y.

10,000....\$1.75; 50,000....\$7.50. Sample free.
For sale by dealers

ROBERT J. DYSART,

Public Accountant and Auditor

Simple methods of correct accounting especially adapted for florists' use.

Books Balanced and Adjusted

Merchants Bank Building

28 STATE ST., BOSTON
Telephone, Main 38.

We manufacture

Self Watering Flower Boxes

for

Windows, Porches and Cemeteries

splendid for placing on

GRAVES

Water reservoir needs refilling but once in two weeks. Made of galvanized iron. Rust proof, leak proof, beautifully finished, and will last for many years. Made in all sizes.

Send \$2.00 for Sample Box

37 in. long and see how quickly you can double your money and also increase the sale of your plants. Illustrated booklet sent free on request

Illinois Heater & Manufacturing Co.

3946 Wentworth Ave., Chicago, Ill.

HART'S HANDY HANDLE

"At Easter-time, with a little chiffon decoration, and the Handle, we were able to increase the value of plants from 50% to 100%."— H. E. WILSON.

Write for descriptive circular and prices

GEO. B. HART, 24 Stone St., Rochester, N. Y.

PERSONAL.

Visitor in Boston: W. E. Chappell, Providence, R. I.

O. C. Bassage of Rochester, N. Y., has taken a position with Burr's Nursery, Manchester Conn.

John Shields, florist, of Dalton, Mass., will sail from New York on July 1 for a two months' trip abroad.

Wayland F. Chase, Middleboro, Mass., has taken a position with the Oregon Nursery Co., Salem, Ore.

Alexander Coburn has been appointed head gardener at Queen Victoria Niagara Falls Park, Canada.

Simon Colitz, Woonsocket, R. I., of the Rustic Flower Store, and Mrs. Esther Caplan of Roxbury, Mass., are to be married on June 11.

R. G. Leavitt, for the past nine years botanist at the Ames laboratory, North Easton, Mass., has accepted a position as professor of botany at the State Normal School, Trenton, N. J.

NEWS NOTES.

The Beeville Nursery Co., Beeville, Texas, has been recently organized.

Leikens, the florist, has opened his Bellevue branch at Newport, R. I., for the season.

I. H. Anderson will carry on business at the Brookside Greenhouses, Reading, Pa.

Hatten & Bieberich have started in business at the East End Greenhouses, Huntington, Ind.

The Illinois Heater and Manufacturing Company, who have been advertising a very serviceable but low-priced window box for plants, will soon put on the market a cemetery vase of galvanized iron similar in form to the glass vases which are so apt to get broken by the lawn mowers.

PROMPT DELIVERY IN BOSTON

AND ALL NEW ENGLAND POINTS

HOUGHTON & CLARK

396 Boylston St., Boston, Mass.



BOSTON'S BEST

In Quality and Design

Can be relied upon when you transfer your retail orders to

EDWARD MACMULKIN

194 Boylston Street, Boston

Send flower orders for delivery in

BOSTON

and all

NEW ENGLAND POINTS

THOS. F. CALVIN

124 Tremont St., Boston

TRANSFER

Your orders for flower or plant delivery in Eastern New England to

JULIUS A. ZINN,

2 Beacon St., Boston.

Fine Design Work a Specialty.

Baskets Made to Order FOR FLORISTS

I have the most skilled Tribe of Pottowattomie Indian basket makers in the world ready to make any thing in the shape of florists' baskets at low prices. Be Original—have your baskets made to order, in your own styles.

E. H. HITCHCOCK, GLENWOOD, MICH.

"FOR JUNE WEDDINGS"

Sweet Peas, very choice, \$1.00 per 100
Valley, \$3.00 and \$4.00 per 100
Beauties, best grade, \$3.00 per dozen
Brides and Maids, choice quality
Cattleyas

The Leo Niessen Company
1209 Arch St., Philadelphia, Pa.
Open from 7 a. m. to 8 p. m.

FOR THE JUNE GIRL

CATTLEYAS
Extra Stock, \$6.00 per doz.
VALLEY

The Come-again kind, No. 1 \$3, Fancy \$4 per 100.

S. S. PENNOCK - MEEHAN CO.
1608-1620 Ludlow St. PHILADELPHIA
"The" Wholesale Florists of Philadelphia

EVERYTHING SEASONABLE IN
CUT FLOWERS
EDWARD REID, Wholesale Florist
1526 Ranstead St., PHILADELPHIA
STORE CLOSES 8 P. M.

CHAS. W. McKELLAR

51 WABASH AVE., CHICAGO

Western Headquarters for Choice Orchids
Valley, Roses and all Cut Flowers

PETER REINBERG
WHOLESALE

CUT FLOWERS

51 Wabash Av., Chicago, Ill.

CUT FLOWER BOXES
EDWARDS FOLDING BOX CO
MANUFACTURERS
PHILADELPHIA, PA.

AMERICAN BEAUTY and all other
ROSES
LILY OF THE VALLEY, CARNATIONS
WELCH BROS., 226 Devonshire St., Boston, Mass.

New Crop Dagger Ferns
\$2.00 per 1000
Case lots of 10 P. at \$1.50 per 1000
W. E. McKISSICK WHOLESALE FLORIST
PHILADELPHIA
1619-1621 RANSTEAD ST.

DAILY CONSIGNMENTS
From 40 to 60 Growers
We can care for your outflow wants to advantage.
E. F. WINTERSON CO.
46-47-48 WABASH AVE., CHICAGO

Rice Brothers
115 N. 6th Street, MINNEAPOLIS, MINN.
WHOLESALE FLORISTS and SUPPLIES
CUT FLOWERS received twice daily, and can fill your orders to your satisfaction. A complete line of Hardy Greens - WILD SMILAX, BOXWOOD, HARDY FANCY FERNS, GALAX LEAVES.
Write for quotations on large quantities.

E. A. BEAVEN
Southern Wild Smilax,
Log Mosses,
Natural and Perpetuated - at Wholesale
EVERGREEN, ALABAMA.

TOWER HOTEL
Niagara Falls, N. Y.
is soliciting your patronage during the S. A. F. Convention.
Very truly yours,
M. J. HOENIG, Prop.

WHOLESALE FLOWER MARKETS—TRADE PRICES—Per 100 TO DEALERS ONLY

	CHICAGO June 2	TWIN CITIES June 1	PHILA. June 1	BOSTON June 4
ROSES				
Am. Beauty, Fancy and Special...	35.00 to 50.00	25.00 to 30.00	18.00 to 25.00	15.00 to 20.00
Extra.....	20.00 to 35.00	15.00 to 22.00	12.00 to 15.00	12.00 to 15.00
No. 1.....	12.00 to 20.00	10.00 to 12.00	8.00 to 10.00	6.00 to 10.00
Lower grades.....	5.00 to 10.00	6.00 to 8.00	3.00 to 5.00	1.00 to 4.00
Bride, Maid, Fancy & Special.....	5.00 to 6.00	6.00 to 8.00	4.00 to 6.00	5.00 to 6.00
Lower grades.....	1.00 to 4.00	2.00 to 5.00	1.00 to 3.00	1.00 to 2.00
Killarney, Richmond, Fan, & Sp.....	6.00 to 8.00	8.00 to 10.00	5.00 to 10.00	5.00 to 6.00
Lower grades.....	2.00 to 6.00	5.00 to 7.00	1.00 to 3.00	1.00 to 4.00
Chateau, Fancy and Special.....	4.00 to 6.00	5.00 to 8.00	4.00 to 6.00	4.00 to 6.00
Lower grades.....	2.00 to 4.00	3.00 to 5.00	1.00 to 2.00	1.00 to 3.00
Kaiserin, Carnot.....	4.00 to 6.00	6.00 to 8.00	2.00 to 8.00	1.00 to 6.00
Golden Gate, Ivory.....	4.00 to 6.00	6.00 to 8.00	2.00 to 6.00	1.00 to 6.00
CARNATIONS				
Fancy and Novelties.....	2.00 to 3.00	2.50 to 3.50	2.00 to 3.00	1.00 to 2.00
Ordinary.....	1.00 to 2.00 to 2.00	.75 to 1.50	.30 to 1.00
MISCELLANEOUS				
Cattleyas.....	40.00 to 50.00	40.00 to 50.00	50.00 to	40.00 to 50.00
Lilies.....	12.00 to 16.00	6.00 to 8.00	8.00 to 10.00	6.00 to 8.00
Lily of the Valley.....	2.00 to 4.00	2.00 to 3.50	2.00 to 4.00	1.00 to 3.00
Daisies.....	.50 to .75	.75 to 1.25	.75 to 1.00	.50 to 1.00
Pansies.....	.35 to 1.00	2.00 to 3.00	25 to .50	.25 to .50
Peonies.....	3.50 to 8.00	6.00 to 10.00	4.00 to 8.00	2.00 to 6.00
Gladioli.....	4.00 to 3.00	5.00 to 15.00	3.00 to	2.00 to 3.00
Mignonette.....	.75 to 1.50	2.00 to 3.00 to 3.00	1.00 to 2.00
Gardenias.....	5.00 to 15.00	5.00 to 15.00	5.00 to 15.00	12.00 to 25.00
Sweet Peas.....	.50 to 1.00	.60 to .75	.35 to .75	.25 to .50
Adiantum.....	.75 to 1.50	.75 to 1.00	1.00 to 1.50	1.00 to 1.50
Smilax.....	10.00 to 20.00	12.00 to 15.00	20.00 to	10.00 to 12.00
Asparagus Plumosus, strings.....	35.00 to 50.00	35.00 to 50.00 to 50.00	25.00 to 50.00
" " & Spren. (roo bchs.)	35.00 to 50.00	35.00 to 50.00	5.00 to 50.00	15.00 to 50.00

J. A. BUDLONG

37-39 Randolph Street, CHICAGO.

Roses and Carnations WHOLESALE CUT FLOWERS
A Specialty..... GROWER OF

REED & KELLER
122 West 25th St., New York
Florists' Supplies

We manufacture all our
Metal Designs, Baskets, Wire Work & Novelties
and are dealers in
Glassware Decorative Greens and Florists' Requisites

J. B. Murdoch & Co.

Wholesale Florista
FLORISTS' SUPPLIES
714 Penn Ave., PITTSBURG, PA.
Long Distance Phone 1435 Court.

H. BAYERSDORFER & CO.

Known to the Trade for the past 30 years as the

Representative Florists' Supply House of America

Always first in the market with anything that is new, novel and appropriate.

FOR THE MONTH OF WEDDINGS AND GRADUATIONS

We have prepared for your needs with a stock of desirable and useful goods, unequalled in quality and extent anywhere on this continent and at prices that cannot be beaten. Orders by mail or telegraph will be filled immediately. Catalogue on application.

H. BAYERSDORFER & CO., 1129 Arch St., Philadelphia

FLOWER MARKET REPORTS

BOSTON Memorial Day business in Boston was a record-breaker in several respects. No such quantity of material has ever been available, the quantity sold was far beyond the record and it was physically impossible to do more than was done in the wholesale places. But the prices were badly cut down, there was a big surplus left over which turned out a complete loss and there have been many complaints from buyers concerning the poor quality of much of the stock. Since the holiday the situation is in no respect improved. Peonies are now coming in freely; carnations are abundant and cheap; roses, with the exception of Beauty, Kaiserin and Carnot, are badly mildewed; outdoor lily of the valley is gone and the forced product is doing better than for some time past; sweet peas are abundant and good. Demand is far behind supply in most lines.

The trade seem to be **BUFFALO** satisfied with the business which was had for Memorial week. Until the first part of the week stock of all kinds was over plentiful, with little or no outlet, and the only thing for the wholesaler was to fill up the coolers. The temperature ran up to 88 degrees in the shade and such out-door stock as tulips, spirea, narcissi, deutzia, lilac and lily of the valley all came in at one time, and at the end of the week when it could have been used to good advantage there was little to be had, as the hot weather had cleaned them up quickly. In the rose line there was plenty to be had and at good quality, including Beauties, but demand was not strong. Peonies helped out considerably, but would not move at high prices as in former years. Carnations were in demand as usual, and sold readily, the colored ones being preferred. Most of the carried-over stock was cleaned up by the cemetery florists. Shipping trade was excellent and equal to former years, but a good portion of stock would not stand shipping.

CHICAGO As was anticipated the Chicago cut flower market was affected by the excessive rains followed by intense heat preceding Memorial Day. The shipping trade especially suffered. Stock was soft and some of the growers had

held back the flowers till they were in no condition for sale anywhere, much less for shipping long distances. Buyers there were in abundance, though many report the individual sales not so large as usual, but an oversupply of flowers and an under-supply of quality helped to demoralize the market. At the beginning prices were very fair and in some localities remained so, but in the overstocked portions prices fell. Florists having a large shipping trade are fearing complaints from dissatisfied customers, for much of the stock was not in best of condition for sending out. Taken all in all, for an off year in business and with unfavorable weather to contend with, Chicago florists pronounce Memorial Day trade for 1908 "fair."

INDIANAPOLIS Memorial Day trade exceeded all expectations of the majority of the florists. All outside flowers, especially peonies, were in full swing. Warm weather has greatly reduced the size of roses and carnations. There seems to be a record breaking supply of everything at the present time with prospects for a big June trade. Weddings and school closings are next in order and already a great number of large advance orders have been booked. Green stock of all kinds is in good supply with an excellent demand.

NEW YORK The heavy influx of flowers has continued unabated and, as our price quotations show, prices on all lines are low and, with the exception of Cattleyas and choice white material for wedding adornment, demand lags badly. Last week was the culmination of an unusual conjunction of supply, weather, and other conditions affecting unfavorably the course of the flower market. Memorial Day was as usual a busy time among the suburban florists especially those located near the cemeteries, but the city proper retail trade

was not overworked and the wholesalers who might ordinarily have done well with the out-of-town trade were balked from start to finish by the tremendous shipments of stock sent to them, most of it in miserable condition and which they were glad to get off their hands at any figure. A rapid shortening up of supply may now be looked for.

PHILADELPHIA Black disaster and calamity is the story for Memorial week in Philadelphia, without a solitary redeeming feature anywhere. Even Memorial Day itself, which is usually good for the plant men at least, was ruined for them also by the tremendous downpour of rain which continued all day. Business was poor all the week and the influx of stock was enormous. Much of it was poor and was never taken out of the boxes. Such a deluge of everything was never seen here before. Roses of all kinds except American Beauty were inferior showing a bad slump for the week. Beauty was the only one that held its own as to quality. Good carnations were not looked for, so no one was disappointed. Sweet peas were no better, with the exception of a few from outdoors which showed a little more hardness, substance, color and finish. Peonies came in all the week with a rush and an immense lot were left over on Saturday night with no hope of moving them. These lovely, fragrant and showy flowers will be with us in quantity for the next ten days or two weeks, and prices until then will be low. We might extend the review to other flowers—but what's the use? The same sad story all along the line. The worst Memorial week on record.

Business in Minneapolis and St. Paul is reported as having been fairly satisfactory during the past week, considering that it has rained steadily a good part of the time.

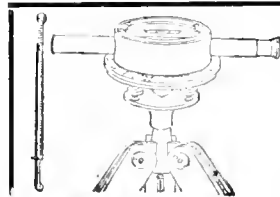

Bostrom Improved Builders' Levels and Farm Levels

For Park, Cemetery and Landscape Gardening use, take the place of expensive Engineering Instruments. Simple in construction, easily adjusted, more substantial and less cumbersome than the more elaborate and complicated instruments. Practical, up-to-date instrument that any one can use. Write for descriptive circulars and be convinced that this Level is necessary to complete your outfit. Builders' Level \$25.00. Farm Level \$12.50.

BOSTROM-BRADY MFG. CO., 139 Madison Avenue., ATLANTA, GA

JOHN YOUNG
WHOLESALE FLORIST
 Finest American Beauties and Carnations
 51½ West 28 St. - NEW YORK

FORD BROTHERS
 48 West 28th Street, NEW YORK
FINE ROSES FANCY CARNATIONS
 A Full Line of All CUT FLOWERS
 Telephone, 3870 or 3871 Madison Square

H. E. FROMENT,
 Wholesale Commission Florist,
 Choice Cut Flowers,
 57 West 28th St., :: NEW YORK.
 Telephones: 2200, 2201, Madison Square.

The Reliable Commission House
 Richmond Roses and Rich Flowers
 of all varieties
JOS. S. FENRICH
 110 W. 28th Street, New York
 Tel. 324-325 Madison Square

Alfred H. Langjahr
 All choice cut-flowers in season. Send
 for quotations. Correspondence with
 shippers of first-class stock invited.
 55 West 28th Street, New York.
 Telephones 4626-4627 Madison Square

JOHN I. RAYNOR
Wholesale Commission Florist SELLING AGENT FOR
 LARGEST GROWERS
 A full line of Choice Cut Flower stock for all purposes. Comprises every variety
 grown for New York market, at current prices
 TEL. 1998 MADISON SQUARE 49 W. 28 St., New York City

Walter F. Sheridan
 Wholesale Commission Dealer in
CHOICE CUT FLOWERS
 39 West 28th Street, New York
 Telephone: 3532-3533 Madison Square

HEADQUARTERS FOR NOVELTIES
ORCHIDS A SPECIALTY
 THE HIGHEST GRADE OF **VALLEY** ALWAYS ON HAND
 GARDENIAS, DAISIES, ROSES AND CARNATIONS
 Telephone
JAMES McMANUS, 759 Mad. Sq. 42 W. 28th St., New York

PHILIP F. KESSLER 55 & 57 W. 26th St., New York City
 Commission Dealer, Wholesale Buyer
 and Seller of
CUT FLOWERS
 Open from 5 a. m. to 6 p. m. Sunday
 till 10 a. m.
 Tel., 5243 and 2921 Madison Sq. Res., 345 J., Newtowna.
Finest Lilies in the Market Every Day in the Year.

WHOLESALE COMMISSION FLORIST
J. K. ALLEN 106 W. 28 ST.
 NEW YORK
 Telephone 167
 Madison Sq.
 OPEN 6 A.M. DAILY
 We have a good regular outlet for seasonable flowers

NEW YORK QUOTATIONS PER 100—TO DEALERS ONLY

	Last Half of Week ending May 30 1908	First Half of Week beginning June 1 1908		Last Half of Week ending May 30 1908	First Half of Week beginning June 1 1908
Roses					
Am. Beauty, laa and sp.	8.00 to 15.00	6.00 to 15.00	Cattleyas	25.00 to 40.00	25.00 to 50.00
" extra	5.00 to 8.00	5.00 to 6.00	Lilies	3.00 to 5.00	3.00 to 4.00
" No. 1	3.00 to 5.00	2.00 to 4.00	Lily of the Valley	1.00 to 2.00	1.00 to 3.00
" Lower grades	.50 to 2.00	.50 to 1.00	Daisies	.25 to .50	.25 to .50
Bride, *Maid, laa and sp.	3.00 to 5.00	3.00 to 5.00	Pansies	.15 to .25	.25 to .50
" lwr. gids.	.50 to 1.00	.50 to 1.00	Peonies	4.00 to 6.00	1.00 to 6.00
Killarney, Richmond, laacy & spec	4.00 to 8.00	3.00 to 6.00	Gladioli	4.00 to 8.00	6.00 to 10.00
" lower grades.	.50 to 2.00	.50 to 2.00	Mignonette	.50 to 1.00	.50 to 1.00
Chatenay, Fancy and Special	3.00 to 6.00	3.00 to 5.00	Gardenias	3.00 to 15.00	5.00 to 15.00
" Lower grades	.50 to 2.00	.5 to 2.00	Sweet Peas per 100 bunches	2.00 to 6.00	2.00 to 5.00
Kaiserio, Carnot.	.50 to 5.00	.50 to 4.00	Adiantum to .50	.25 to .50
Golden Gate, Ivory	.50 to 4.00	.50 to 4.00	Smilax	8.00 to 12.00	8.00 to 12.00
Carnations, Fancy and Novelties	1.00 to 2.00	1.00 to 1.50	Asparagus Plumosus, strings	15.00 to 25.00	15.00 to 25.00
" Ordinary	.50 to 1.00	.30 to .50	" " & Sprea. (100 bchs.)	15.00 to 25.00	15.00 to 25.00

Edward C. Horan
Wholesale Florist
 55 WEST 28th ST.
 Tel. 1462 1463 Madison Square New York

TRAENDLY & SCHENCK
WHOLESALE FLORISTS
 Furnish best stock at fair prices all the year round Send for quotations on fall orders
 Tel. 798-799 Madison Sq. 44 West 28th Street, New York City

Moore, Hentz & Nash,
 Wholesale Commission Florists,
 55 and 57 West 26th Street,
 Telephone No. 756
 Madison Square. New York.

Alexander J. Guttman
THE WHOLESALE FLORIST OF NEW YORK
 34 WEST 28th STREET
 PHONES. 1664-1665 MADISON SQUARE
ENOUGH SAID



HARDY CUT FERNS

Sphagnum floss, Extra Large Bales, per bale, \$1.25. Fancy and Dagger Ferns our specialty. A trial order will convince you that we ship only first-class stock. Headquarters for Florists' supplies and wire work. All cut flowers in season. **BOXWOOD**, per bunch 35c, 50 lbs. \$7.50.

MICHIGAN CUT FLOWER EXCHANGE, INC., All 'phone connections **38-40 Broadway, Detroit, Mich.**

FANCY and DAGGER
Extra fine, \$1.75 per 1000. Bronze and Green Galax, \$1.25 per 1000. Leucothoe Sprays, \$1.00 per 100, \$7.50 per 1000.

Headquarters in Western New York
FOR
ROSES, CARNATIONS
And all kinds of Seasonable Flowers
Wm. F. Kasting Co.
Wholesale Commission Florist, also Dealer in
Florists' Supplies and Wire Designs.
383-87 ELLICOTT ST.
BUFFALO, N. Y.
Give us a trial. We can please you.

FRANK S. HICKS & CO.
Wholesale Florists.
Open Now for Consignments of Cut Flowers.
39 West 28th Street, - New York City
Tel. 2920 Mad. Sq.

WILLIAM H. KUEBLER
Brooklyn's Foremost and Best
WHOLESALE COMMISSION HOUSE
A First Class Market for all CUT FLOWERS
28 Willoughby St., Brooklyn, N. Y.
Tel. 4591 Main

 **Henry M. Robinson & Co.** 
Wholesale and Commission
FLORISTS

Hardy Cut Evergreens and Florists' Supplies
NEW CROP DAGGER AND FANCY FERNS, \$2.00 per M.
15 Province St. and 9 Chapman Place, Boston, Mass.

Flowers and Florists' Supplies
The best place in AMERICA to buy
BAY TREES
N. F. McCarthy & Co.
84 Hawley St., BOSTON, MASS.
Largest Dealers in Supplies In New England.

SAMUEL A. WOODROW
WHOLESALE PLANTSMAN
Palms, Large and Small Ferns, etc.
53 West 30th Street, NEW YORK
Telephone 2083 Madison

In ordering goods please add "I saw it in HORTICULTURE."

BOSTON FLORIST LETTER CO.
Manufacturers of FLORISTS' LETTERS

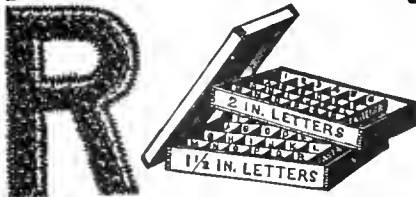

This wooden box nicely stained and varnished, 18x30x12, made in two sections, one for each size letter, given away with first order of 500 letters
Block Letters, 1 1/2 or 2 inch size per 100, \$2.
Script Letters, 3. Fastener with each letter or word. Used by leading florists everywhere and for sale by all wholesale florists and supply dealers
N. F. MCCARTHY, Manager
66 Pearl Street, BOSTON, MASS.

WHOLESALE FLOWER MARKETS. — PER 100. — TO DEALERS ONLY.

	CINCINNATI May 26	DETROIT June 1	BUFFALO June 1	PITTSBURG June 1
ROSES				
Am. Beauty, Fan. and Sp.....	20.00 to 25.00	20.00 to 25.00	20.00 to 25.00	15.00 to 20.00
" Extra	15.00 to 20.00	15.00 to 18.00	15.00 to 20.00	10.00 to 12.00
" No. 1	8.00 to 10.00	8.00 to 15.00	8.00 to 15.00	6.00 to 8.00
" Lower grades.....	4.00 to 6.00	3.00 to 6.00	2.00 to 5.00	2.00 to 4.00
Bride, "Maid, F. & S.....	5.00 to 6.00	6.00 to 8.00	6.00 to 8.00	4.00 to 6.00
" Low. gr.....	2.00 to 4.00	3.00 to 6.00	5.00 to 6.00 to 2.00
Killarney, Richmond, Fan. & Sp.....	6.00 to 8.00	6.00 to 8.00	6.00 to 8.00	6.00 to 8.00
" Lower grades.....	3.00 to 4.00	3.00 to 6.00	3.00 to 6.00	2.00 to 4.00
Chatenay, Fancy and Special.....	6.00 to 8.00	6.00 to 8.00	6.00 to 8.00	6.00 to 8.00
" Lower grades.....	3.00 to 4.00	3.00 to 6.00	3.00 to 6.00 to 4.00
Kaiserin, Carnot.....	4.00 to 6.00	4.00 to 8.00	2.00 to 6.00	2.00 to 10.00
Golden Gate, Ivory.....	4.00 to 6.00	4.00 to 8.00	2.00 to 6.00	4.00 to 8.00
CARNATIONS				
Fancy and Novelties.....	2.50 to 3.00	3.00 to 4.00	2.00 to 2.50	2.00 to 3.00
Ordinary.....	1.00 to 2.00	2.00 to 3.00	1.50 to 2.00	1.00 to 1.50
MISCELLANEOUS				
Cattleyas.....	40.00 to 50.00	35.00 to 50.00	60.00 to 75.00	35.00 to 50.00
Lilies.....	8.00 to 10.00	12.50 to	10.00 to 15.00	10.00 to 12.00
Lily of the Valley.....	2.00 to 4.00	3.00 to 4.00	3.00 to 4.00	2.00 to 4.00
Daisies.....	.50 to 1.00	.50 to 1.00	.50 to 1.00	.50 to 1.50
Pansies.....	3.00 to 4.00	.50 to 1.00	.25 to .50 to .50
Peonies.....	6.00 to 8.00	4.00 to 8.00	3.00 to 5.00	3.00 to 6.00
Giadioli.....	4.00 to 6.00	3.00 to 8.00	4.00 to 6.00	4.00 to 6.00
Mignonette.....	1.00 to 2.00	1.00 to	1.00 to 2.00 to 2.00
Gardenias..... to 2.00	15.00 to 25.00	1.00 to 3.00	1.00 to
Sweet Peas.....	.50 to .75	.50 to .75	.40 to .75	.25 to .50
Adiantum..... to 1.00	1.00 to 1.50	.50 to 1.00 to 1.25
Smilax.....	10.00 to 12.00	15.00 to 18.00 to 15.00 to 15.00
Asparagus Plumosus, strings.....	40.00 to 50.00	50.00 to 60.00	40.00 to 50.00	35.00 to 50.00
" " & Spren. (too bchs.)	25.00 to 35.00	30.00 to 50.00	25.00 to 50.00	25.00 to 40.00

H. G. BERNING
Wholesale Florist
1402 Pine Street, ST. LOUIS, MO.

A. MOLTZ
Will purchase flowers on order in N. Y. market and ship carefully at prevailing wholesale prices. Address
55-57 West 26th Street, New York City

MILLANG BROS.
WHOLESALE COMMISSION FLORISTS
41 West 28th Street
NEW YORK
Telephone 3860 Madison 3861

GLEARY'S HORTICULTURAL CO.
Management AMBROSE T. CLEARY
Wholesale Contracting, Jobbing, Auction
HORTICULTURAL PRODUCTS
of every description.
Consignments Received. Surplus Stock Converted.
62 Vesey St., NEW YORK

In writing to Advertisers kindly mention Horticulture

Buyer's Directory and Ready Reference Guide

Advertisements under this head, one cent a word. Initials count as words.

Regular advertisers in this issue are also listed under this classification without charge. Reference to List of Advertisers will indicate the respective pages.

Buyers failing to find what they want in this list will confer a favor by writing us and we will try to put them in communication with reliable dealers.

ACCOUNTANT

R. J. Dysart, 28 State St., Boston.
For page see List of Advertisers.

ARAUCARIAS

A. Leuthy & Co., Perkins St. Nurseries,
Roslindale, Mass.
For page see List of Advertisers.

John McKenzie, North Cambridge, Mass.

ASPARAGUS

A. N. Pierson, Cromwell, Conn.
Asparagus Plumosus Seedlings.
For page see List of Advertisers.

J. M. Thornburn & Co., 33 Barclay St.,
New York.

Plumosus Nanus and P. Robustus.
For page see List of Advertisers.

Asparagus plumosus and Sprengerii, 2-In.
strong, \$2.25 per 100. J. H. Dann & Son,
Westfield, N. Y.

Asparagus Plumosa, 2 in. pots. Fine
plants, \$3.00 per 100; \$25.00 per 1000. Cash
with order or good reference. Erle Floral
Co., Erie, Pa.; or, Wm. F. Kasting Co.,
385 Ellicott St., Buffalo, N. Y.

ASPARAGUS SEED

Warren Shinn, Woodstown, N. J.

ASTER SEED

Altimo Culture Co., Canfield, O.
For page see List of Advertisers.

AUCTION SALES

Clery's Horticultural Co., 62 Vesey St.,
New York.

For page see List of Advertisers.

Wm. Elliott & Sons, 42 Vesey St., New York.
The Fruit Auction Co., 2024 Franklin St.,
New York.

Auction Sales Daily (Except Monday).

AZALEAS

A. Leuthy & Co., Perkins St. Nurseries,
Roslindale, Mass.

For page see List of Advertisers.

August Reiker & Sons, New York, 31 Bar-
clay St., or P. O. Box 752.

For page see List of Advertisers.

BAMBOO CANES

Yokohama Nursery Co., 31 Barclay Street,
New York.

For page see List of Advertisers.

BAY TREES.

N. F. McCarthy & Co., 84 Hawley St.,
Boston.

For page see List of Advertisers.

2000 Bay and Box Trees in all sizes,
Pyramid and Standards. Write for list.
Julius Roehrs, Rutherford, N. J.

BEDDING PLANTS

B. Vincent, Jr., & Sons Co., White Marsh,
Maryland.

For page see List of Advertisers.

A. N. Pierson, Cromwell, Conn.
For page see List of Advertisers.

A. Leuthy & Co., Perkins St. Nurseries,
Roslindale, Mass.

For page see List of Advertisers.

F. R. Pierson Co., Tarrytown-on-Hudson,
N. Y.

For page see List of Advertisers.

Wm. S. Hegger, Morris Plains, N. J.

For page see List of Advertisers.

BEDDING PLANTS - Continued

Godfrey Aschmann,
1012 W. Ontario St., Phila., Pa.
For page see List of Advertisers.

40,000 geraniums, 10 best standard sorts;
5000 *Viola variegata*; *Salvia*; *hellebore*,
dark; *feverfew*, double white. Good stock,
prices right. E. D. Kaulback & Son, Mal-
den, Mass.

Geraniums, all the best varieties, \$8.00
to \$10.00 per 100; *Verbenas*, from 3.12-in.
pots \$6.00 per 100; *Single Petunias*, fine
stock, \$6.00 per 100; *Vernon Begonia*, pink,
white and red, \$6.00 per 100; *Phlox Drum-*
mondii, \$4.00 per 100; *Cobea Scandens*,
4-in. fine, \$7.00 per 100; *Tuberous Begonia*
in colors, fine plants, \$10.00 to \$15.00
per 100. All of this stock is first-class in
every respect and satisfaction is guar-
anteed. Wilfrid Wheeler, Concord, Mass.

BEGONIAS

Thomas Roland, Nahant, Mass.
Gloire De Lorraine.

For page see List of Advertisers.

S. S. Skidelsky, 1741 N. 18th St., Phila.
Gloire de Lorraine.

For page see List of Advertisers.

Tuberous Begonias, best single, fine
tubers, \$1.50 per 100. Schlegel & Pottler
Co., 26 South Market St., Boston.

Begonia Gloire Lorraine, strong plants
from leaf cuttings, 2 1/4 inch pots, \$12.00
per 100; \$110.00 per 1000. Julius Roehrs,
Rutherford, N. J.

BERBERIS THUNBERGII

Oak Hill Nurseries, Roslindale, Mass.
For page see List of Advertisers.

BOILERS

BOILERS. "Burnham" Boilers made for
greenhouse heating. Lord & Burnham,
1133 Broadway, N. Y.

Kroeschell Bros. Co., 35 Erie St., Chicago.
For page see List of Advertisers.

BUILDERS' AND FARM LEVELS

Bostrom-Brady Co., 139 Madison Ave.,
Atlanta, Ga.

For page see List of Advertisers.

BUILDING MATERIAL

BUILDING MATERIAL of all descrip-
tion for All Cypress, Semi-iron, Iron
Frame or Truss Houses. Hot Bed Sash
and Frames. Lord & Burnham Co., 1133
Broadway, N. Y.

BULBS AND TUBERS

Joseph Breck & Sons, 47-54 N. Market St.,
Boston.

For page see List of Advertisers.

J. M. Thornburn & Co., 33 Barclay St.,
New York.

For page see List of Advertisers.

A. T. Boddington, 342 W. 14th St., N. Y.
For page see List of Advertisers.

Rickards Bros., 37 East 19th St., New York.
For page see List of Advertisers.

H. F. Mitchell Co., Philadelphia.

For page see List of Advertisers.

H. E. Flske Seed Co., Fanenil Hall Sq.,
Boston.

For page see List of Advertisers.

James Vick's Sons, Rochester, N. Y.

Fall Bulbs.

For page see List of Advertisers.

Aug. Rolker & Sons, 31 Barclay St., New
York.

Seasonable Import Plants and Bulbs.

For page see List of Advertisers.

W. J. Eldering & Son, Overveen, Haarlem,
Holland.

High Grade Dutch Bulbs.

BULBS AND TUBERS - Continued

K. Velthuys, Hillegom, Holland,
Represented by Felix Bosch, 260 Clarendon
St., Boston.

Bulbs French and Dutch.

For page see List of Advertisers.

A. Mitting, 17-23 Kennan St., Santa Cruz,
California.

Calla Bulbs.

For page see List of Advertisers.

CANNAS

The Conard & Jones Co., West Grove, Pa.
For page see List of Advertisers.

Godfrey Aschmann,

1012 W. Ontario St., Phila., Pa.
For page see List of Advertisers.

Estate of David Fisher, Woburn, Mass.

For page see List of Advertisers.

E. & C. Woodman, Dauvers, Mass.

For page see List of Advertisers.

The F. R. Pierson Co., Tarrytown-on-
Hudson, N. Y.

For page see List of Advertisers.

CARE OF TREES

H. L. Frost & Co., White Plains, N. Y.;
Arlington, Mass.

For page see List of Advertisers.

CARNATIONS

F. Dornier & Sons Co., Lafayette, Ind.
For page see List of Advertisers.

Chicago Carnation Co., Joliet, Ill.

For page see List of Advertisers.

John E. Haines, Bethlehem, Pa.

Carnations Imperial and Pink Imperial.

For page see List of Advertisers.

A. N. Pierson, Cromwell, Conn.

For page see List of Advertisers.

The F. R. Pierson Co., Tarrytown-on-
Hudson, N. Y.

For page see List of Advertisers.

H. F. Littlefield, 552 Main St.,

Worcester, Mass.

For page see List of Advertisers.

Albert Roper, Tewksbury, Mass.

Carnation Bay State.

For page see List of Advertisers.

Carnation cuttings of all the leading
varieties at the same price as any reliable
firm. Write for prices before you look
elsewhere. Wm. F. Kasting Co., 385
Ellicott St., Buffalo, N. Y.

CARNATIONS! FIELD GROWN!!

15,000 Enchantress and Winsor, ready for
delivery July 1st. Orders filled in strict
rotation. Order now and be first! Prices
on application. We guarantee satisfaction.
We lead in superb field grown stock.

WANOKA GREENHOUSES,
Barneveld, N. Y.

CAULIFLOWER AND CABBAGE SEED

H. Hartmann & Co., Copenhagen,
Denmark.

For page see List of Advertisers.

CHRYSANTHEMUMS

Chas. H. Totty, Madison, N. J.

For page see List of Advertisers.

A. N. Pierson, Cromwell, Conn.

For page see List of Advertisers.

H. F. Littlefield, 552 Main St., Worcester,
Mass.

Rooted Cuttings.

For page see List of Advertisers.

Herrington's book on the Chrysanthem-
um, mailed to your address for 50c., by
Horticulture Publishing Co., 11 Hamilton
Place, Boston.

For List of Advertisers See Page 773

CHRYSANTHEMUMS — Continued

H. L. Cameron, No. Cambridge, Mass.
For page see List of Advertisers.

Chrysanthemums ready; 2 12 inch strong stock of Touse, Oct. Frost, Polly Rose, Wanamaker, and all standards, \$2 per 100, \$18 per M. New; 2 12, strong, Alice Roosevelt, Hankey, Clay Frick, Winter Cheer, Rosette, B. May, \$4 per 100, \$30 per M. Cash. Send for catalog. Harlowarden Greenhouses, Greenport, N. Y.

Have 100,000 fine young well-rooted 'Mums, cuttings of the best 60 commercial varieties. Seed for our new and low price list. Satisfaction guaranteed. Wm. Ehmans, Jr., Corfu, N. Y.

COBAEAS

Cobaea scandens from 4 in. pots, \$8.00 per 100. Witthold Co., 1657 Buckingham Place, Chicago, Ill.

COLEUS

A. N. Pierson, Cromwell, Conn.
For page see List of Advertisers.

CONIFERS

John Waterer & Sons, Ltd., American Nursery, Bagshot, Eng.
For page see List of Advertisers.

CUT FLOWER BOXES.

Edwards Folding Box Co., Philadelphia.
For page see List of Advertisers.

Folding cut flower boxes, the best made. Write for list. Holton & Hunkel Co., Milwaukee, Wis.

CYCLAMEN.

Cyclamen, finest Giant strain, separate colors, once transplanted seedlings, 2c.; twice transplanted, 3c.; strong, from 2-in. pots, 4c. J. L. Schiller, 929 Prouty Ave., Toledo, O.

DAHLIAS

David Herbert & Son, Atco, N. J.
For page see List of Advertisers.

R. Vincent, Jr. & Sons Co., White Marsh, Maryland.
For page see List of Advertisers.

Dahlias, balance of season, 25 named varieties, postpaid, \$1.00. Catalogue free. J. L. Moore, Northboro, Mass.

Dahlias: About 2000 Cath. Duer, Kriemhilde, Brunhilde, Snowclad, etc., \$3 per 100. Cash. Harlowarden Greenhouses, Greenport, N. Y.

DECORATIVE PLANTS

A. Leuthy & Co., Perkins St. Nurseries, Roslindale, Mass.
For page see List of Advertisers.

Godfrey Aschmann,
1012 W. Ontario St., Phila., Pa.
For page see List of Advertisers.

DRACAENAS

E. & C. Woodman, Danvers, Mass.
For page see List of Advertisers.

Dracaena indivisa: 4 in., \$2.00 per doz., \$12.00 per 100; 5 in., \$3.00 per doz., \$20.00 per 100. Witthold Co., 1657 Buckingham Place, Chicago, Ill.

ECHEVERIAS

Echeverias, \$18 per 1000, post paid. McDowell, Mexico City.

ELECTRIC CIRCULATOR

The Castle Co., 170 Summer St., Boston.
For page see List of Advertisers.

FERNS

A. Leuthy & Co., Roslindale, Mass.
For page see List of Advertisers.

H. H. Barrows & Son, Whitman, Mass Nephrolepis Whitman.
For page see List of Advertisers.

John Scott, Brooklyn, N. Y.
For page see List of Advertisers.

The F. R. Pierson Co., Tarrytown-on-Hudson, N. Y.
For page see List of Advertisers.

FERTILIZERS

Pulverized Manure Co., 31 Union Stock Yards, Chicago, Ill.

Wizard Brand Cattle Manure.
For page see List of Advertisers.

FERTILIZERS — Continued

Thos. J. Grey & Co.,
32 and 33 South Market St., Boston.
High-Grade Scotch Soot.
For page see List of Advertisers.

FLORAL PHOTOGRAPHS

Floral Photographs. Foley's 226-228 1-2 Bowery, New York.

FLORISTS' LETTERS.

Boston Florist Letter Co., 66 Pearl St., Boston, Mass.
For page see List of Advertisers.

FLORISTS SUPPLIES

N. F. McCarthy & Co., 84 Hawley St., Boston.
For page see List of Advertisers.

M. M. Robinson & Co., 15 Province St. and 9 Chapman Pl., Boston, Mass.
For page see List of Advertisers.

Seed & Keller, 122 W. 25th St., New York.
For page see List of Advertisers.

J. B. Murdoch & Co., 714 Penn Ave., Pittsburg, Pa.
For page see List of Advertisers.

H. Bayersdorfer & Co., 1129 Arch St., Philadelphia.
For page see List of Advertisers.

FLOWERS BY TELEGRAPH

Park Floral Co., Denver, Colo.
For page see List of Advertisers.

J. N. Champlon & Co., 1026 Chapel St., New Haven, Conn.
For page see List of Advertisers.

Gude Bros. Co., 1214 F St., Washington, D. C.
For page see List of Advertisers.

Atlanta Floral Co., Atlanta, Ga.
For page see List of Advertisers.

M. C. & J. E. Hauswirth, 232 Michigan Ave., Chicago.
For page see List of Advertisers.

William J. Smyth, Michigan Ave. and 31st St., Chicago.
For page see List of Advertisers.

George Witthold Co., 1657-59 Buckingham Place, Chicago.
For page see List of Advertisers.

Jacob Scholz, 644 4th Ave., Louisville, Ky.
For page see List of Advertisers.

Thos. F. Galvin, 124 Tremont St., Boston.
For page see List of Advertisers.

Julius A. Ziun, 2 Beacon St., Boston.
For page see List of Advertisers.

Houghton & Clark, 396 Boylston St., Boston.
For page see List of Advertisers.

Sidney Hoffman, 59-61 Massachusetts Ave., Boston.
For page see List of Advertisers.

Edward MacMullin, 194 Boylston St., Boston.
For page see List of Advertisers.

J. Breitmeyer's Sons, Miami and Gratiot Aves., Detroit, Mich.
For page see List of Advertisers.

Samuel Murray, 1017 Broadway, Kansas City, Mo.
For page see List of Advertisers.

Wm. L. Rock Flower Co., 1118 Walnut St., Kansas City, Mo.
For page see List of Advertisers.

Fred C. Weber, 4326-28 Olive St., St. Louis, Mo.
For page see List of Advertisers.

H. G. Eyres, 11 N. Pearl St., Albany, N. Y.
For page see List of Advertisers.

David Clarke's Sons, 2159-2141 Broadway, New York.
For page see List of Advertisers.

Alex. McConnell, New York.
For page see List of Advertisers.

M. A. Bowe, 1294 Broadway, New York.
Robert G. Wilson, Fulton St. & Greene Av., Brooklyn, N. Y.
For page see List of Advertisers.

Young & Nugent, 42 W. 28th St., N. Y.
For page see List of Advertisers.
J. H. Dunlop, 96 Yonge St., Toronto, Can.
For page see List of Advertisers.

FLOWER BOXES

Illinois Heater & Mfg. Co., 3946 Wentworth Ave., Chicago, Ill.
Self Watering for Windows, Porches and Cemeteries.
For page see List of Advertisers.

FLOWER POTS

W. H. Ernest, 28th and M Sts., Washington, D. C.
For page see List of Advertisers.

A. H. Hews & Co., Cambridge, Mass.
For page see List of Advertisers.

Hilfinger Bros., Ft. Edward, N. Y.
For page see List of Advertisers.

Red pots, seed pans, etc.
The Peters & Reed Pottery Co., Zanesville, O.

GALAX

Michigan Cut Flower Co., 38 and 40 Broadway, Detroit, Mich.
For page see List of Advertisers.

GERANIUMS

R. Vincent Jr. & Sons Co., White Marsh, Md.
New and Standard Varieties.
For page see List of Advertisers.

Godfrey Aschmann,
1012 W. Ontario St., Phila., Pa.
For page see List of Advertisers.

Wm. W. Edgar Co., Waverley, Mass.
For page see List of Advertisers.

H. L. Cameron, No. Cambridge, Mass.
For page see List of Advertisers.
Geraniums, 2 in., double red, \$1.50 per 100. J. H. Dann & Son, Westfield, N. Y.

GLADIOLI

Gladiolus, large flowering mixed, balance of season, \$1.00 per 100; postpaid. J. L. Moore, Northboro, Mass.

GLASS

Boston Plate & Window Glass Co., Boston.
For page see List of Advertisers.

Standard Plate Glass Co., 26-30 Sudbury St., Boston.
For page see List of Advertisers.

S. Jacobs & Sons, 1365-79 Flushing Ave., Brooklyn, N. Y.

Metropolitan Material Co., 1398-1408 Metropolitan Ave., Brooklyn, N. Y.
For page see List of Advertisers.

Foley Mfg. Co., Western Ave., between 25th & 26th Sts., Chicago.

Sharp, Partridge & Co., 22d & Lumber St., Chicago.
For page see List of Advertisers.

Greenhouse glass, lowest prices. Johnston Glass Co., Hartford City, Ind.

GLASS, High Grade, Double Thick Greenhouse Glass. Lord & Burnham, 1133 Broadway, N. Y.

GLAZING POINT

H. A. Dreer, Philadelphia, Pa.
For page see List of Advertisers.

GLAZING POINTS, Lord & Burnham Special Glazing Nails (Points). Lord & Burnham, 1133 Broadway, N. Y.

GREENHOUSE BUILDING MATERIAL

Lord & Burnham Co.,
1133 Broadway, New York.
For page see List of Advertisers.

Pierson U-Bar Co., 1 Madison Sq., N. Y.
For page see List of Advertisers.

A. T. Stearns Lumber Co., Neponset, Boston.
For page see List of Advertisers.

King Construction Co., N. Tonawanda, New York.
For page see List of Advertisers.

J. C. Moulner Co., 117 East Blackhawk St., Chicago, Ill.
For page see List of Advertisers.

Foley Mfg. Co., Western Ave., between 25th & 26th Sts., Chicago.
For page see List of Advertisers.

I. Cassidy, Summer Ave. and Erie R. R., Newark, N. J.
For page see List of Advertisers.

In writing to Advertisers kindly mention Horticulture

GREENHOUSE BUILDING MATERIAL—Continued

Geo. B. Doane, 18 Midway St., Boston.
Iron Pipe.
For page see List of Advertisers.

B. Jacobs & Sons, 1363-79 Flushing Ave.
Brooklyn, N. Y.

Metropolitan Material Co., 1398-1408 Metro
politan Ave., Brooklyn, N. Y.
For page see List of Advertisers.

GREENHOUSE CONSTRUCTION
GREENHOUSE CONSTRUCTION, Semi
Iron Greenhouse, New Truss Houses and
Iron Frame Houses. Lord & Burnham,
1183 Broadway, N. Y.

J. A. Payne, 260-274 Culver Ave., Jersey
City, N. J.
For page see List of Advertisers.

I. Cassidy, Summer Ave. and Erie R. R.,
Newark, N. J.
For page see List of Advertisers.

Foley Mfg. Co., Western Ave., between
25th & 26th Sts., Chicago.
For page see List of Advertisers.

Wm. H. Luton, West Side Avenue Sta.,
Jersey City, N. J.
Curved Iceless Eave.
For page see List of Advertisers.

GUTTERS

GUTTERS, Cast Iron Gutters, L. & B
Improved V Shaped Gutter with drip gutter
attachment. Lord & Burnham, 1183
Broadway, N. Y.

HAIL INSURANCE

Florists' Hall Asso. of America.
J. G. Ealer, Saddle River, N. J.
For page see List of Advertisers.

HARDY FERNS AND SUPPLIES

H. M. Robinson & Co., 15 Province St.
and 9 Chapman Pl., Boston, Mass.
For page see List of Advertisers.

Michigan Cut Flower Exchange,
88 and 40 Broadway, Detroit, Mich.
Fancy Ferns.
For page see List of Advertisers.

HART'S HANDY HANDLE

Geo. B. Hart, 24 Stone St., Rochester, N. Y.
For page see List of Advertisers.

HEATING APPARATUS

Lord & Burnham Co.,
1183 Broadway, New York.

For page see List of Advertisers.

Pierson U-Bar Co., 1 Madison Sq., N. Y.
For page see List of Advertisers.

John A. Payne, 260-274 Culver Ave., Jersey
City, N. J.
For page see List of Advertisers.

HEDGE PLANTS

Peter's Nursery, Knoxville, Tenn.
For page see List of Advertisers.

HELP FURNISHED

Thos. H. Bambrick, 34 S. 7th St., Phila.
For page see List of Advertisers.

HERBACEOUS PERENNIALS

Bay State Nurseries, No. Abington, Mass.
For page see List of Advertisers.

P. Onwerkerk, P. O. No. 2, Hoboken, N. J.
For page see List of Advertisers.

HOSE

Henry A. Dreer, 714 Chestnut St., Phila.
Riverton Hose.

HOT-BED SASH

The A. T. Stearns Lumber Co., Neponset,
Mass.

For page see List of Advertisers.

Pierson U-Bar Co., 1 Madison Sq., N. Y.
For page see List of Advertisers.

Lord & Burnham Co., 1183 Broadway, N. Y.
For page see List of Advertisers.

Foley Mfg. Co., Western Ave., between
25th & 26th Sts., Chicago.

HYDRANGEAS.

W. W. Edgar Co., Waverley, Mass.
For page see List of Advertisers.

F. R. Pierson Co., Tarrytown-on-Hudson,
N. Y.
Hydrangea Otaksa.
For page see List of Advertisers.

INSECTICIDES.

Nicotifield kills all greenhouse pests
P. R. Paethorpe Co.,
Eleventh St., Owensboro, Ky.
For page see List of Advertisers.

IRISES

J. M. Thorburn & Co., 33 Barclay St.,
New York.
For page see List of Advertisers.

JAPANESE PLANTS

Yokohama Nursery Co., 31 Barclay St.,
New York.
For page see List of Advertisers.

JUMPING BEANS

Jumping Beans, \$5 per 1000, post paid.
McDowell, Mexico City.

KENTIAS

A. Leathy & Co., Roslindale, Mass.
For page see List of Advertisers.
Jos. Hancock Co., Wyncote, Pa.
For page see List of Advertisers.

LOBELIAS

Double Lobelia, Kathleen Mallard, 2 1/4
ln., 4c. Strong cuttings from soil, all
full of buds and bloom. J. L. Stone,
Trumansburg, N. Y.

MASTICA

F. O. Pierce Co., 12 W. Broadway,
New York.
For page see List of Advertisers.

MOON VINES

Godfrey Aschmann, 1012 W. Ontario St.,
Philadelphia.
For page see List of Advertisers.

MYOSOTIS

Denys Zirglebel, Needham, Mass.

MYRTLE

Myrtle for cemetery planting, strong
field grown clumps, \$2.00 per 100, or \$17.50
per 1000. Geo. A. Dhouan, East Walnut
Hills, Cincinnati, O.

NEW AND RARE PLANTS

Rose Hill Nurseries, New Rochelle, N. Y.
For page see List of Advertisers.

NICO-FUME

Kentucky Tobacco Product Co.,
Louisville, Ky.
For page see List of Advertisers.

NURSERY STOCK

John Waterer & Sons, Ltd.,
American Nursery, Bagshot, England.
For page see List of Advertisers.
Bay State Nurseries, N. Abington, Mass.
Herbaceous Perennial, Hardy Ornamental
Trees.

For page see List of Advertisers.
Cleary's Horticultural Co., 62 Vesey St.,
New York.

For page see List of Advertisers.
P. Onwerkerk, 216 Jane St., Weehawken
Helghts, N. J.

Holland Nursery Stock for Forcing.
For page see List of Advertisers.
American Nursery Co., 150 Broadway, New
York, N. Y.

For page see List of Advertisers.
Peter's Nursery Co., Knoxville, Tenn.
Live Fences; Amor sod California Privet.
For page see List of Advertisers.

ORCHID PLANTS

Lager & Hurrell, Summit, N. J.
For page see List of Advertisers.
Sander, St. Albans, England.
Importers, Exporters, Growers, Hybridists
For page see List of Advertisers.

Julius Roehrs Co., Rutherford, N. J.
For page see List of Advertisers.

Carrillo & Baldwin, Secaucus, N. J.
For page see List of Advertisers.

Jos. A. Manda, 191 Valley Road, W.
Orange, N. J.
For page see List of Advertisers.

Ordenez Bros., Madison, N. J., Box 106
For page see List of Advertisers.
Largest stock in the country. Ask for
prices. Julius Roehrs, Rutherford, N. J.

PALMS

A. Leathy & Co., Perkins St. Nurseries,
Roslindale, Mass.

For page see List of Advertisers.

Robert Craig Co., Market and 49th Sts.,
Philadelphia, Pa.
For page see List of Advertisers.

August Rolker & Sons, 31 Barclay St.,
New York.

For page see List of Advertisers.

Joseph Hancock Co., Wyncote, Pa.
Home-Grown Palms.

For page see List of Advertisers.

PAINT AND PUTTY

PAINT AND PUTTY: Ideal Greenhouse
Lead; Special Greenhouse Putty. Lord &
Burnham, 1183 Broadway, N. Y.

PANSIES

Pansies, Superb Strain, 1.50 per 100;
\$10.00 per 1000. Cash with order. Walter
R. Cobb, Canton, Mass.

Giant pansy plants in bloom, young,
healthy plants; very beautiful colors, \$1.50
per 100. Cash. M. Welterling, Ionia,
Mich., Pansy Specialist.

PATENTS

Siggers & Siggers, Washington, D. C.
For page see List of Advertisers.

PEAT

Orchid peat, Rotted peat, Azalea peat,
Leaf-Mould, Live Sphagnum moss, Baled
Sphagnum moss, Green Clump moss, etc.
Jobbers' list on application. C. W. Brown-
ell & Co., Walden, N. Y.

PELARGONIUMS

R. Vincent, Jr. & Sons Co., White Marsh,
Maryland.
For page see List of Advertisers.

PEONIES

Wholesale Peony list for fall 1908 is now
ready. J. F. Rosenfield, West Point, Neb.
One of the finest collections in America.
Send 25 cts. in stamps for new edition of
Peony Manual. C. S. Harrison's Select
Nursery, York, Neb.

PETUNIAS

Star Petunias from 2-in. pots, fine, clean
plants, \$2.00 per 100, \$18.00 per 1000. W.
E. Hall, Clyde, O.

PHLOXES

Send 25 cts. in stamps for Phlox Manual.
Fine mixed phloxes \$1.50 per 100. C. S.
Harrison's Select Nursery, York, Neb.

PIPE AND FITTINGS

Foley Mfg. Co., between Western Ave. and
26th St., Chicago, Ill.
For page see List of Advertisers.

PIPE AND FITTINGS. Cast Iron and
Wrought Pipe, Valves, Elbows, Pipe Hooks,
Automatic Air Headers, etc. Lord &
Burnham, 1183 Broadway, N. Y.

PLANT STAKES AND TRELLISES

Seele's Patent, for roses, chrysanthemums,
gladioli, tuberoses, dahlias tomatoes,
egg plants, etc. H. D. Seele & Sons,
Manuf., Elkhart, Ind.

POT HANGERS

Pot hangers, Kramer's \$1 doz. by exp.,
\$1.25 by mail. I. N. Kramer & Son, Cedar
Rapids, Ia.

PRIMULA SEED

H. E. Fiske Seed Co., 13 Faneull Hall Sq.,
Boston.

For page see List of Advertisers.

O. V. Zaegen, Hoboken, N. J.

For page see List of Advertisers.

RAFFIA

Raffia (colored), 20 beautiful shades
Samples free. R. H. Comey Co., Camden,
N. J.; 810 Washburn Ave., Chicago, Ill.

For List of Advertisers See Page 773

RETAIL FLORISTS

- Park Floral Co., Denver, Colo.**
For page see List of Advertisers.
- Gude Bros. Co., 1214 F St., Washington, D. C.**
For page see List of Advertisers.
- Atlanta Floral Co., Atlanta, Ga.**
For page see List of Advertisers.
- M. C. & J. E. Hauswirth, 232 Michigan Ave., Chicago.**
For page see List of Advertisers.
- William J. Smyth, Michigan Ave. and 31st St., Chicago.**
For page see List of Advertisers.
- George Wittbold Co., 1657-59 Buckingham Place, Chicago.**
For page see List of Advertisers.
- Jacob Schulz, 644 4th Ave., Louisville, Ky.**
For page see List of Advertisers.
- Thos. F. Galvin, 124 Tremont St., Boston.**
For page see List of Advertisers.
- Jillins A. Zinn, 2 Beacon St., Boston.**
For page see List of Advertisers.
- Houghton & Clark, 396 Boylston St., Boston.**
For page see List of Advertisers.
- Sidney Hoffman, 59-61 Massachusetts Ave., Boston.**
For page see List of Advertisers.
- Edward MacMulkin, 194 Boylston St., Boston.**
For page see List of Advertisers.
- J. Brettmeyer's Sons, Detroit, Mich.**
For page see List of Advertisers.
- Samuel Murray, 1017 Broadway, Kansas City, Mo.**
For page see List of Advertisers.
- Wm. L. Rock Flower Co., 1116 Walnut St., Kansas City, Mo.**
For page see List of Advertisers.
- Fred C. Weber, 4326 Olive St., St. Louis, Mo.**
For page see List of Advertisers.
- J. N. Champlin & Co., 1026 Chapel St., New Haven, Conn.**
For page see List of Advertisers.
- H. G. Eyres, 11 N. Pearl St., Albany, N. Y.**
For page see List of Advertisers.
- David Clarke's Sons, 2139-2141 Broadway, New York.**
For page see List of Advertisers.
- Alex. McConnell, New York.**
For page see List of Advertisers.
- M. A. Bowe, 1294 Broadway, New York.**
- Robert G. Wilson, Fulton St. and Greene Ave., Brooklyn, N. Y.**
For page see List of Advertisers.
- Young & Nugent, 42 W. 23th St., N. Y.**
For page see List of Advertisers.
- J. H. Dunlop, 96 Yonge St., Toronto, Can.**
For page see List of Advertisers.

RHODODENDRONS

- John Waterer & Sons, Ltd., American Nursery, Bagshot, England.**
For page see List of Advertisers.
- P. Ouwerkerk, Hoboken, N. J.**
For page see List of Advertisers.
- Eastern Nurseries, Jamaica Plain, Mass.**
Hardy Hybrid and Dwarf Rhododendrons.
For page see List of Advertisers.

ROSES

- Bay State Nurseries, N. Abington, Mass.**
For page see List of Advertisers.
- Robert Orsig Co., Market and 49th Sts., Philadelphia, Pa.**
For page see List of Advertisers.
- Dodge-Conard Co., West Grove, Pa.**
For page see List of Advertisers.
- R. & J. Farquhar & Co., 6 and 7 South Market Street, Boston.**
For page see List of Advertisers.
- The E. G. Hill Co., Richmond, Ind.**
Roses, Rhea Reid, American Beauty.
For page see List of Advertisers.
- Poehlmann Bros. Co., Morton Grove, Ill.**
Mrs. Potter Palmer, Cardinal, Beauty.
For page see List of Advertisers.
- P. R. Quinlan, Syracuse, N. Y.**
Killarney, Richmond, Bridesmaids.
For page see List of Advertisers.
- P. Ouwerkerk, P. O. No. 2, Hoboken, N. J.**
For page see List of Advertisers.

ROSES — Continued

- Henry A. Dreer, 714 Chestnut St., Phila.**
Potted Roses.
- Crimson Rambiers, 2 year, on own roots, extra strong, at 7 cents.** Gilbert Costich, Rochester, N. Y.
- Low-budded roses, No. 1, \$95.00; No. 1-2, \$65.00 1000.** H. T. Jones, Elizabeth, N. J.
- The beautiful new pink rose, MISS KATE MOULTON is the queen of all pink roses. It's a winner and you should grow it.** Price \$30.00 100; 500 \$125.00; 1000 \$200.00; 5000 and upwards \$175 per 1000. Minneapolis Floral Co., Minneapolis, Minn.

RUBBER PLANTS

- John McKenzie, North Cambridge, Mass.**

S. A. F. CONVENTION ACCOMMODATIONS

- Tower Hotel, Niagara Falls, N. Y.**
For page see List of Advertisers.

SALVIAS

- Cohanzie Carnation Co., New London, Ct.**
Salvia Splendens.
For page see List of Advertisers.

SEEDS

- T. J. Grey Co., 82 So. Market St., Boston, Mass.**
For page see List of Advertisers.
- Joseph Breck & Sons, 51 and 52 N. Market St., Boston, Mass.**
For page see List of Advertisers.
- W. Atlee Burpee & Co., Philadelphia.**
For page see List of Advertisers.
- J. M. Thorburn & Co., 33 Barclay St., N. Y.**
For page see List of Advertisers.
- A. T. Boddington, 342 W. 14th St., N. Y.**
For page see List of Advertisers.
- H. F. Mitchell Co., 1017 Market St., Phila.**
For page see List of Advertisers.
- James Vick's Sons, Rochester, N. Y.**
Vick's Superb Pansy Seed.
For page see List of Advertisers.
- Hjalmar Hartmann & Co., 12 Stormgade, Copenhagen, Denmark.**
Cauliflower and Cabbage Seed.
For page see List of Advertisers.
- Rickards Bros., 37 E. 19th St., New York.**
For page see List of Advertisers.
- R. & J. Farquhar & Co., 6-7 So. Market St., Boston.**
For page see List of Advertisers.
- C. C. Morse & Co., 48-56 Jcsksoo St., San Francisco, Cal.**
- Braslan Seed Growers Co., San Jose, Cal.**
For page see List of Advertisers.
- H. E. Fiske Seed Co., Faneuil Hall Sq., Boston.**
Primula Fringed Sineusis.
For page see List of Advertisers.
- O. V. Zangen, Hoboken, N. J.**
For page see List of Advertisers.
- John F. Rupp, Shrewmanstown, Pa.**
Chinese Primrose, Cineraria, Giant Pansy Seeds.
For page see List of Advertisers.

SLUG SHOT

- Hammond's Paint & S. S. Works, Fishkill-on-Hudson, N. Y.**

SMILAX

- Smilax, choice young plants from fall.** \$3.00 per 1000, 2000 for \$5.00, 5000 for \$10.00; 50c. per 100 by mail. F. A. Baller, Bloomington, Ill.

SPHAGNUM MOSS

- Live Sphagnum moss, orchid peat and orchid baskets always on hand.** Lager & Hurrell, Summit, N. J.
- Fresh, clean, 5 bbl. bale, \$1.25; 2 bales, \$2.25; 5 bales, \$5.00; 10 bales, \$9.50.** Cash. H. R. Akers, Chatsworth, N. J.

SPRAYERS

- Charles J. Jager Co., 281-85 Franklin St., Boston.**
For page see List of Advertisers.
- "SHOWERMAKER," St. Jos. Kopesay, So. Bend, Ind.**

STEAM TRAP

- E. Hippard, Youngstown, O.**
For page see List of Advertisers.

SWEET PEAS

- A. C. Zvolanek, Round Brook, N. J.**
Winter Flowering.
For page see List of Advertisers.

TO-BAK-INE

- E. H. Hunt, Genl. Agt., 76-78 Wabash Av., Chicago.**
For page see List of Advertisers.

TUBEROSES

- Stump & Walter Co., 50 Barclay St., New York.**
For page see List of Advertisers.
- No. 1 Pearl Tuberose bulbs, \$5.00 per 100.** Schlegel & Pottier Co., 25 South Market St., Boston.

VEGETABLE PLANTS

- R. Vincent, Jr. & Sons Co., White Marsh, Maryland.**
For page see List of Advertisers.
- W. W. Edgar Co., Waverley, Mass.**
Tomato Plants.
For page see List of Advertisers.

VENTILATING APPARATUS

- Parson U-Bar Co., 1 Madison Sq., N. Y.**
For page see List of Advertisers.
- Foley Mfg. Co., Western Ave., between 25th & 26th Sts., Chicago.**
For page see List of Advertisers.
- John A. Payne, 260-274 Culver Ave., Jersey City, N. J.**
For page see List of Advertisers.

- The Advance Co., Richmond, Ind.**
For page see List of Advertisers.
- Quaker City Machine Co., Richmond, Ind.**
20th Century Ventilating Arm.
For page see List of Advertisers.

- VENTILATING MACHINERY, New Model encased, self-rolling gear; Standard Model Open Gear.** Lord & Burnham, 1133 Broadway, N. Y.

VERBENAS

- Cohanzie Carnation Co., New London, Conn.**
Lemon Verbena.
For page see List of Advertisers.
- Mammoth Verbenas, fine large plants from soil, coming in bud.** 60c. per 100, by mail; \$4.00 per 1000, by express. Samuel Whitton, 15 Gray Ave., Utica, N. Y.

VIOLETS.

- Lady Campbell violets, 25,000 extra fine, sand-rooted cuttings, \$1.00 per 100, by mail; \$7.00 per 1000, by express; 500 at 1000 rate. Satisfaction guaranteed.** Field-grown plants of Campbell and California ready in August. Chas. Black, Hightstown, N. J.
- Maria Louise and Farquhar violet plants, strong, February and March sand struck, clean and free from disease, \$2.00 per 100; \$15.00 per 1000. Will be ready May 15. Cash with order, please.** C. Lawritzen, Box 261 Rhinebeck, N. Y.
- How to Make Money Growing Violets, will be sent postpaid for 25c., by Horticulture Publishing Co., 11 Hamilton Place, Boston.**
- Violet cuttings, "Maria Louisa" Rhinebeck stock, rooted runners, May delivery \$20.00 M.** Wm. F. Kasting Co., 383 Elliott St., Buffalo, N. Y.]

- Commercial Violet Culture, by R. T. Galway, sent postpaid for \$1.50, by Horticulture Publishing Co., 11 Hamilton Place, Boston.**

- California violets, extra strong, healthy plants, \$1.00 per 100; \$7.00 per 1000.** Fred E. Holland, Highland, Ill.

VINCAS

- E. & C. Woodman, Danvers, Mass.**
For page see List of Advertisers.
- Vinca Variegata, extra strong, long vines from 4 in., \$10.00 per 100; cash.** Converse Greenhouses, Webster, Mass.

WIRED TOOTHPICKS

- W. J. Cowee, Berlin, N. Y.**
For page see List of Advertisers.

WIREWOK

- Reed & Keller, 122 W. 25th St., N. Y.**
For page see List of Advertisers.
- Wirework. Write for our catalogue.** Holton & Hunkel Co., Milwaukee, Wis.
- William E. Hellscher's Wire Works, 38-40 Broadway, Detroit, Mich.**

In writing to Advertisers kindly mention Horticulture

WIREWORK - Continued

Headquarters for wire work. Send for list. Hall & Betz, 31 E. 3rd St., Cincinnati, O.

**WHOLESALE FLORISTS
Boston**

- N. F. McCarthy & Co., 84 Hawley St., Boston.
For page see List of Advertisers.
- H. M. Robineon & Co., 15 Province St. and 9 Chapin Pl., Boston.
For page see List of Advertisers.
- Welch Bros., 228 Devonshire St., Boston.
For page see List of Advertisers.

Buffalo

- Wm. F. Kastling Co., 383-87 Ellicott St., Buffalo, N. Y.
For page see List of Advertisers.

Chicago

- Chas. W. McKellar, 51 Wabash Ave., Chicago.
For page see List of Advertisers.
- Peter Reinberg, 51 Wabash Ave., Chicago.
For page see List of Advertisers.
- E. F. Winterson Co., 45-49 Wabash Ave., Chicago.
For page see List of Advertisers.
- J. A. Budlong, 37-39 Randolph St., Chicago.
For page see List of Advertisers.

Detroit

- Michigan Cut Flower Exchange, 38 and 40 Broadway, Detroit, Mich.
For page see List of Advertisers.

Minneapolis

- Rice Bros., 115 N. 6th St., Minneapolis, Minn.
For page see List of Advertisers.

New York

- J. K. Allen, 106 W. 28th St., New York
For page see List of Advertisers.
- J. S. Fenrich, 110 W. 28th St., New York
For page see List of Advertisers.
- Ford Bros., 48 W. 28th St., New York
For page see List of Advertisers.
- H. E. Froment, 57 W. 28th St., New York
For page see List of Advertisers.
- Alex. J. Guttman, 34 W. 28th St., New York
For page see List of Advertisers.
- E. C. Horan, 55 W. 28th St., New York
For page see List of Advertisers.
- A. H. Langjahr, 55 W. 28th St., New York
For page see List of Advertisers.
- James McManus, 42 W. 28th St., New York
For page see List of Advertisers.
- John I. Raynor, 40 W. 28th St., New York
For page see List of Advertisers.
- W. F. Sheridan, 39 W. 28th St., New York
For page see List of Advertisers.
- Traendly & Schenck, 44 W. 28th St., New York.
For page see List of Advertisers.
- John Young, 51 W. 28th St., New York
For page see List of Advertisers.
- Moore, Hentz & Nash, 55 and 57 W. 28th St., New York.
For page see List of Advertisers.
- Frank S. Hicks & Co., 39 W. 28th St., New York.
For page see List of Advertisers.
- Wm. H. Kuebler, 28 Willoughby St. Brooklyn, N. Y.
For page see List of Advertisers.
- Phillip F. Kessler, 55 and 57 W. 28th St., New York.
For page see List of Advertisers.

New York - Continued

- A. Moltz, 55-57 W. 28th St., New York.
For page see List of Advertisers.
- Millang Bros., 41 W. 28th St., New York.
For page see List of Advertisers.

Philadelphia

- W. E. McKissick, 1619-1621 Ranstead St., Philadelphia, Pa.
For page see List of Advertisers.
- Leo Nielsen Co., 1209 Arch St., Philadelphia, Pa.
For page see List of Advertisers.
- The S. S. Pennock-Meehan Co., 1608-16 Ludlow St., Philadelphia, Pa.
For page see List of Advertisers.
- Edward Iteld, 1526 Ranstead St., Philadelphia, Pa.
For page see List of Advertisers.

Pittsburg

- J. B. Murdoch & Co., 714 Penn Ave., Pittsburgh, Pa.
For page see List of Advertisers.

St. Louis

- H. G. Berning, 1402 Pine St., St. Louis, Mo.
For page see List of Advertisers.

WHOLESALE PLANTSMAN

- Samuel A. Woodrow, 53 W. 30th St., New York.
For page see List of Advertisers.

WILD SMILAX

- E. A. Beaven, Evergreen, Ala.
Southern Wild Smilax: Log Mosses.
For page see List of Advertisers.

New Offers in This Issue.

ACHYRANTHES: ALTERNANTHERA.

- Floral Hill Gardens, Chatham, N. J.
For page see List of Advertisers.

ASTERS: MARGUERITE CARNATIONS.

- Geo. H. Walker, N. Dighton, Mass.
For page see List of Advertisers.

BEDDING PLANTS.

- Vern L. Schurruff, Erie, Pa.
For page see List of Advertisers.

CANNAS.

- Frank Cummings Bulb & Plant Co., Meridian, Miss.
For page see List of Advertisers.

FERNS FOR JARDINIERS.

- Frank N. Eskesen, Madison, N. J.
For page see List of Advertisers.

FLORISTS' BASKETS TO ORDER.

- E. H. Hitchcock, Glenwood, Mich.
For page see List of Advertisers.

PRIMULA OBCONICA GRANDIFLORA SEED.

- H. F. Michell Co., Philadelphia.
For page see List of Advertisers.

PLANT TUBS.

- H. A. Ducey, 714 Chestnut St., Phila.
For page see List of Advertisers.

STERILIZED SHEEP MANURE.

- Wm. Elliott & Sons, 42 Vesey St., New York.
For page see List of Advertisers.

SWEET PEAS FOR THANKSGIVING AND CHRISTMAS.

- Arthur T. Boddington, 342 W. 14th St., New York.
For page see List of Advertisers.

WANTS, FOR SALE, ETC.

Advertisements in this column one cent a word. Initials count as words. Cash with order. All correspondence addressed "care HORTICULTURE" should be sent to 11 Hamilton Place, Boston.

SITUATIONS WANTED

GOOD MEN

When you need good men, skilled or unskilled, Write:

THOS. H. BAMBRICK

34 South 7th Street Philadelphia

Help of all kinds, including that for Florists, Nurserymen, Seedsmen and the Horticultural trade generally.

HELP WANTED

WANTED

A thoroughly experienced man on Hardy and Half-hardy Shrubs and Trees, familiar with propagating, trimming and care.

Address S. M. A., care HORTICULTURE, 11 Hamilton Place, Boston.

SITUATION WANTED By young Scotchman, age 24 years, as foreman in commercial or private place. Well up in the growing of carnations, chrysanthemums, etc.; also landscape work. Apply W. C. care HORTICULTURE.

TRAVELLER WANTED

by leading import house handling all kinds of foreign nursery and florists' stock—excepting Dutch Bulbs. Splendid opening for young man (under 25) with energy, judgment, intelligence and a fair knowledge of the business.

State age, qualifications and salary expected to "Import," care of Horticulture.

HORTICULTURE needs a wide-awake representative in every town in the land. Good commission paid on advertising and subscriptions. If you are ambitious, write for terms.

FOR SALE

FOR SALE, 4 Greenhouses

About 20,000 sq. ft., well stocked with chrysanthemums, carnations, violets, etc.; steam heated; 15 acres of land suitable for market gardening; 8 room dwelling, steam heated; large barn; city water; about 10 miles from Boston; good transportation facilities. Possession given at any time desired by buyer. For particulars write

G. A. ANDERSON, 392 Washington St., Woburn, Mass.

GREENHOUSE FOR SALE.

About 14,000 feet of glass, two steam boilers, one hot water; easy communication to Boston and New York, 1-4 mile to depot; trolley freight passes greenhouses. Three acres of land, large two story dwelling house, large wholesale and retail business. Books open for inspection. Ill health reason for selling. Address Horticulturist, care of HORTICULTURE.

FOR SALE—Special—Glass for sale below cost. 16 x 24 double thick American A. & B. qualities, below cost, for immediate acceptance. Never such an opportunity offered before. Write Parshelsky Bros., 59 Montrose Ave., Brooklyn, N. Y.

SPECIAL SURPLUS LIST

These prices holding good only until present surplus is reduced.

	Per 100		Per 100
Begonia Rex, fine collection of varieties,	\$3.00	Baby Rambler Rose	\$2.00
Begonia Thurstoni and N. Daw	2.50	Clothilde Souper Rose	2.50
Fuchsias - strong stock, all varieties	2.50	Salvia Splendens	2.50
Violet, Prince of Wales	2.50	Ivy Geraniums	2.50
Verbenas, all colors	2.50	Dracena Indivisa	2.50
Pandanus Utilis, 1/2 in.	4.00	Pelargoniums, 7 in.	10.00
Pandanus Utilis, 1 in.	8.00	Digitalis, two colors, field grown	4.00
Kaiserin Rosen, Fresh propagation	3.00	Campanula in variety, field grown	4.00
		Shasta Daisy, in variety, field grown	4.00

THE STORRS & HARRISON CO., Painesville, Ohio

List of Advertisers

Page	Page
Advance, The Co. 775	Kuebler Wm H. 767
Allen J. K. 766	Lager & Hurrell 759
Altimo Culture Co. 761	Langjahr, Alfred H. 716
American Nursery. 748	Leuthy A. & Co. 746
American Nursery Co. 748	Lord & Burnham Co. 776
Anderson G. A. 772	Littlefield H. F. 759
Achmann G. 746-747	Lutton W. H. 775
Atlanta Floral Co. 762	Manda Jos. A. 759
Bambrick Thos. H. 772	MacMulkin E. A. 763
Barrows H. H. & Son. 759	McCarthy N. F. & Co. 767
Bayersdorfer H. & Co. 765	McConnell Alex. 762
Bay State Nurseries. 748	McKellar Charles W. 764
Beaven E. A. 764	McKissick, W. E. 764
Berniog H. G. 767	McManus Jas. 766
Boddington A. T. 757 761	Metropolit. Ma-
Boston Florist Letter	terial Co. 774
Co. 767	Michell H. F. Co. 760-761
Boston Plate and Win-	Michigan Cut Flower
dow Glass Co. 774	Exchange. 767
Bosch, Felix. 747	Millag Bros. 767
Bostrom-Brady Mig.	Mitting, A. 746
Co. 765	Moltz, A. 767
Braslan Seed Growers	Moninger J. C. 775
Co. 761	Moore, Heutz & Nash. 766
Breck Joseph & Sons. 761	Murdoch J. B. & Co. 764
Brettmeyer's J. Sons. 762	Murray Samuel. 762
Bridgeman's Seed	Neipp G. F. 747
Warehouse. 761	Niessen Leo. Co. 764
Budlong J. A. 764	Oak Hill Nurseries. 748
Burpee W. A. & Co. 761	Ordonez Bros. 759
Cameron H. L. 759	Ouwkerk P. 748
Carrillo & Baldwin. 759	Paletborpe P. R. Co. 760
Cassidy I. 775	Park Floral Co. 762
Castle Co. 774	Payne John A. 773
Champion J. N. & Co. 762	Pennock-Meehan Co. 764
Chicago Carotation	Perkins St. Nurseries. 746
Co. 747	Peter's Nursery Co. 748
Clarke's David, Sons. 762	Pierce F. O. Co. 775
Clary's Horticultural	Pierson, A. N. 747
Co. 767	Pierson F. R. Co. 759
Cohanzie Carnation	Pierson U Bar Co. 776
Greenhouses. 747	Pechlmann Bros. Co. 748
Conard & Jones Co. 746	Pulverized Manure Co. 760
Cowee W. J. 763	Quaker City Machine
Craig, Robt. Co. 747	Co. 775
Cummings Frank. 746	Quinlan P. R. 759
Dingee & Conard Co. 748	Rawson W. W. & Co. 760
Doane Geo. B. & Son. 775	Raynor John L. 766
Dorner F. Sons & Co. 747	Reed & Keller. 764
Dreer H. A. 773-775	Reid Edw. 764
Duolop John H. 762	Reinberg Peter. 761
Dysart R. J. 763	Rice Bros. 764
Eastern Nurseries. 748	Rickards Bros. 761
Edgar, W. W. Co. 746	Robinson H. M. & Co. 767
Edwards Folding Box	Rock Wm. L. Flo. Co. 762
Co. 764	Rochrs Julius Co. 759
Elliott Wm. & Sons. 760	Roher Albert. 747
Esler J. G. 775	Roland, Thomas. 746
Ernest W. H. 773	Rolker August & Sons
Eskeisen Frank K. 759 747-773
Eyres. 762	Rose Hill Nurseries. 746
Farquhar R. & J. & Co. 759	Rupp J. E. 761
Fenrich J. S. 766	Sander & Son. 759
Fisher, Estate of	Schluraff Vern L. 749
David. 746	Schult Jacob. 762
Fiske, H. E. Seed Co. 761	Scott, John. 759
Floral Hill Gardens. 747	Sharp, Partridge & Co. 774
Foley Mig. Co. 775	Sheridan W. F. 766
Ford Bros. 766	Siggers & Siggers. 774
Froment H. F. 766	Situations & Wants. 772
Frost H. L. & Co. 748	Skidelsky S. S. 747
Galvin Thos. F. 763	Smyth Wm. J. 762
Grey T. J. Co. 761	Standard Plate Glass
Gude Bros. Co. 762	Co. 774
Guttman Alex. J. 766	Stearns A. T. Lumber
Haerens A. 747	Co. 775
Hall Asso. 775	Storrs & Hargis. 772
Haines, J. E. 747	Stumpp & Walter Co.
Hart, Geo. B. 763 746-760
Hartmann Hjalmar &	Thorburn J. M. & Co. 761
Co. 727	Totty Chas. H. 759
Hauswirth M. C. & J. E. 761	Tower Hotel. 764
Heacock Joseph. 747	Traendly & Schenck. 766
Herbert David & Son. 719	Vaentline, J. A. 762
Herzog Wm. S. 747	Veltbuys K. 747
Hews A. H. & Co. 773	Velch's Jas. Sons. 761
Hicks Frank S. & Co. 767	Vincent R. Jr. & Sons,
Hilfinger Bros. 773 746-757
Hill, The E. G. Co. 748	Walker G. H. 757
Hippard F. 774	Waterer John & Sons. 748
Hitchcock E. H. 763	Weathered Co. 776
Hoerig M. J. 794	Weber F. C. 762
Hoffman. 763	Welch Bros. 764
Horan E. C. 766	Wilson. 762
Houghton & Clark. 763	Winterson, E. F. Co. 764
Hunt E. H. 760	Witthold Geo. Co. 762
Illinois Heating &	Woodman E. & C. 746
Mig. Co. 763	Woodrow, Sam'l A. 767
Jäger, Chas. J. Co. 76n	Yokohama Nursery Co. 746
Kasting W. F. 767	Young, John. 766
Kentucky Tobacco	Young & Nugent. 762
Product Co. 760	Zangen O. V. 761
Kessler, P. F. 766	Zinn Julius A. 763
Kling Cons. Co. 775	Zovlanc A. C. 761
Kroeschell Bros. Co. 774	

IS YOUR NAME IN THE ABOVE LIST? IF NOT, WHY NOT?

GREENHOUSES BUILDING OR CONTEMPLATED.

Wellsville, N. Y.—V. R. Bruce, one house.
 Littleton, Colo.—S. T. Culp, house, 40 x 50.
 Peoria, Ill.—C. Loveridge, two rose houses.
 Boone, Iowa.—M. J. Lockard, range of houses.
 Lincoln, Neb.—Wyuka Cemetery, one house.
 Richmond, Ind.—Glen Miller park, one house.
 Milwaukee, Wis.—J. Kremer, improvements.
 Hamilton, Ont.—W. Holt, two houses, each 25 x 100.
 Cape May, N. J.—E. J. Hamilton, conservatory.
 Blackwell, Okla.—John Heintz, rose house 25 x 80.
 Whitman, Mass.—A. A. Reed & Son, improvements.
 Philadelphia, Pa.—A. Friedriksdorf, addition 30 x 50.
 Park Ridge, Ill.—Edward Meuret, range of houses.
 Indianapolis, Ind.—Smith & Young Co., range of houses.
 Stockbridge, Mass.—S. W. Woodward, carnation house.
 Walla Walla, Wash.—Huff & Young, carnation house, 20 x 100.
 Milwaukee, Wis.—G. Pohl, one house, 30x108, one, 18x100.
 Amherst, Mass.—Massachusetts Agricultural College, range of houses.
 John F. Kidwell, of Chicago, is building a greenhouse plant consisting of 65,000 sq. ft. of glass at Belmont, on the Burlington R. R., first station west of Downer's Grove. This place will be operated by a son and a nephew of Mr. Kidwell.

LIST OF PATENTS.

- 887,810. Combined Disk Harrow and Land Roller. Lewis L. Jackson, Rockwall, Texas.
- 887,960. Storage Device for Seed-Corn. Carl J. Orstrum, Cambridge, Ill.
- 888,058. Shrubbery-Cutter. Charles Berg, New York, N. Y.
- 888,147. Garden Implement. William C. Doidge, Lodi, Cal.
- 888,348. Cultivator-Feeder. Atherton B. Nichols, Hastings, Minn.
- 888,459. Fruit Picker. Herman J. Bolinski, New London, Wis.
- 888,927. Bean Puller. Michael J. Quinsey, Hesperia, Mich.

Other Business Men May "Ease Up"

during the heated term but the florist does not. His greenhouses must be repaired and it takes Glass and Pipes and Lumber to do it.

Now Is The Time To Advertise If You Want His Trade.

His Boiler must be made right now: if you sell heating apparatus get him to buy a new one. Perhaps the time has come for a new watering system. You can reach him most effectually through an advertisement in these pages,

JUST NOW.

JOHN A. PAYNE GREENHOUSE Designer & Builder

260-274 Culver Ave. JERSEY CITY, N. J.

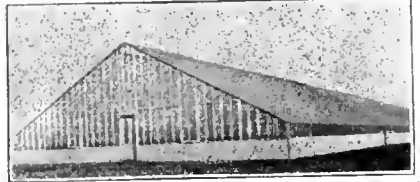

IRON FRAME SEMI-IRON FRAME TRUSS ROOF WOOD FRAME
Material Only or Erected
 Everything for the Greenhouse



STANDARD FLOWER POTS

Packed in small crates, easy to handle.

Price per crate	Price per crate	
1500 2 in. pots in crate \$4.88	120 7 in. pots in crate \$4.20	
1500 2 1/2 " " " 5.25	60 8 " " " 3.00	
1500 3 " " " 6.00	HAND MADE	
1000 3 " " " 5.00	48 9 in. pots in crate \$3.60	
800 3 1/2 " " " 5.80	48 10 " " " 4.80	
500 4 " " " 4.50	24 11 " " " 3.60	
320 5 " " " 4.51	12 14 " " " 4.80	
144 6 " " " 3.16	6 16 " " " 4.50	

Send pans, same price as pots. Send for price list of Cylinders for Cut flowers, Hanging Baskets, Lawn Vases, etc. Ten per cent. off for cash with order. Address **Hilfinger Bros., Pottery, Fort Edward, N. Y.** August Rolker & Sons, Agts., 81 Barclay St., N. Y. City.

Standard Flower POTS

If your greenhouses are within 500 miles of the Capital, write us, we can save you money

W. H. ERNEST

28th and M Street WASHINGTON D. C.

DREER'S Florist Specialties. **KEYSTONE CEDAR PLANT TUBS.**



Three largest sizes have handles

Special PAUL TUBS.
 8 inches 30 3.50 28.00
 11 " " 30 3.50 28.00

Painted Green.

HENRY A. DREER,
 714 Chestnut Street, PHILADELPHIA, PA.

You will find something worth reading on every page of HORTICULTURE.

RATINGS

Mean Boiler Capacity -- There are Two Kinds of Ratings, Nominal and Actual Capacities

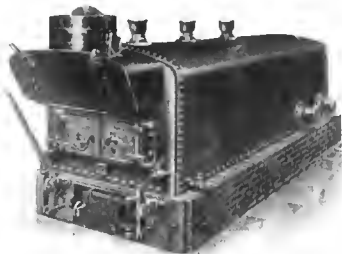

In considering our boiler, please bear in mind that the Kroeschell Boiler is absolutely the only boiler which is constructed exclusively for Greenhouse heating.

The Kroeschell Boiler is rated differently from any other type of boiler. In our ratings we consider greenhouse heating only and on a basis of pipe radiation.

You may not be aware of this fact, but it is true nevertheless, that pipe radiation contains a much greater volume of water than do cast iron radiators.

Since all other boiler manufacturers figure their ratings on cast iron radiation in compact buildings, residences, etc., their rating is much too high for greenhouse heating, and it is for this reason that the salesmen of other boilers will invariably insist upon your purchasing a boiler with a rated capacity of 25% to 35% greater than your requirements would indicate.

Our ratings are actual net capacity based on greenhouse pipe radiation, that is, the boiler will carry the rated amount in your greenhouses exclusive of the mains.

Therefore, in comparing the price of our boiler with those of other makes, and in order to put us on the same basis, you must compare ours with boilers of rated capacity, at least 25% to 35% higher than our rating, and even then we know that our boiler will do the work easier than the other.

"THE KROESCHELL BOILER is the quickest heating boiler I ever saw, and so easy to fire," write hundreds of our customers.

KROESCHELL BROS. CO., 35 ERIE ST., CHICAGO

Don't Build

without first investigating the best device ever invented for *Heating Economy.*

Don't Repair

until you have got some information as to how we can help you by installing the

ELECTRIC CIRCULATOR

State your proposition and we will reply promptly. It will cost you nothing but a two cent stamp.

THE CASTLE COMPANY, HEATING ENGINEERS
170 Summer Street, - BOSTON, MASS.

PATENTS

Trademarks and Copyrights

Send your business direct to Washington. Saves time and insures better service. Personal attention guaranteed. Twenty-five years' active service. SPECIALTY: "Working on the Failure of Others."

SIGGERS & SIGGERS

PATENT LAWYERS

Box 9, National Union Building
Washington, D. C.

METROPOLITAN MATERIAL CO. GREENHOUSE WRECKERS

GLASS Look at these prices. New American 50 ft. to the box, 10 x 12 single \$1.60 per box, 10x12, 12x12 B, double \$2.00 per box, 12x14 to 12x20, 14x14 to 14x20, 16x16 and 16x18 B, double at \$2.15 per box, and 16x20, 16x24, 12x24 B double \$2.26 per box. Discount on large quantities. Let us quote you on

CYPRESS MATERIAL HOTBED SASH BOILERS PIPE FITTINGS HOTBED FRAMES PLATS

1393-1408 METROPOLITAN AV., BROOKLYN, N. Y.

BOSTON PLATE & WINDOW GLASS CO.

GREENHOUSE GLASS
German and American

261 to 287 A St., Boston 20-22 Canal St.

THE STANDARD STEAM TRAP

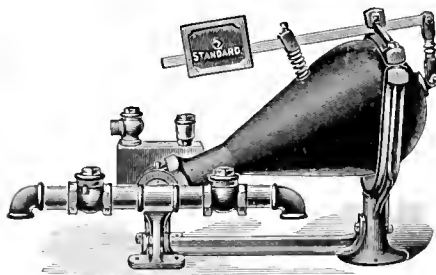

is acknowledged the best for the florist, because it is durable and does its work without trouble and annoyance, saving its cost by the economy in coal bills.

E. HIPPARD

YOUNGSTOWN, OHIO

STANDARD PLATE GLASS CO.

Manufacturers—Importers—Jobbers

NOW IS THE TIME TO BUY

FRENCH OR AMERICAN GREENHOUSE GLASS

LOWEST PRICES ON REQUEST

26-30 Sudbury St. BOSTON, MASS. 61-63 Portland St.

GLASS Always Write Us Before Buying
SHARP, PARTRIDGE & CO.
22nd and Lumber Streets, CHICAGO
WE HAVE SOME SNAPS

In writing to Advertisers kindly mention Horticulture

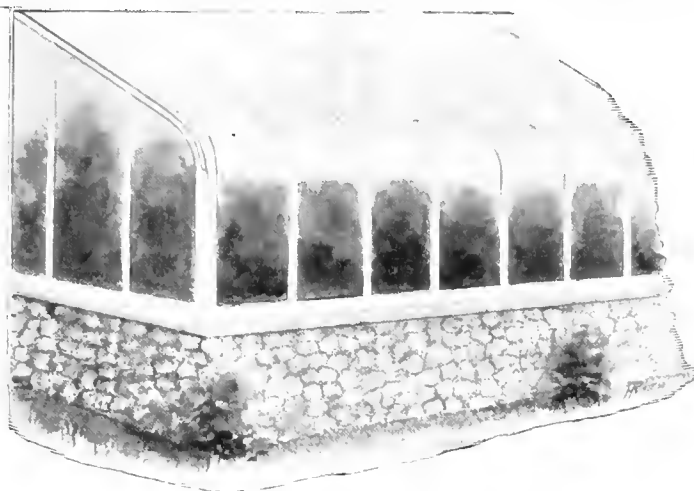

PATENT APPLIED FOR

Why My New Curved Iceless Eave is Far Superior to Anything on the Market Today

- 1st. No sash bars incased in iron, thereby eliminating all danger of bars decaying.
- 2nd. Can be used in conjunction with iron frame construction, thereby doing away with that very objectionable feature, "columns."
- 3rd. Roof bars with drip grooves, which act as conductors to carry away the condensation: **Result**, the driest roof ever used for greenhouse purposes.
- 4th. **THE MOST IMPORTANT OF THEM ALL.** The very small increase in cost over the ordinary style of construction which makes it possible to be used for commercial as well as private purposes.

William H. Lutton, Horticultural Architect and Builder
West Side Ave Station (C.R.R. of N.J.) Jersey City, N.J.

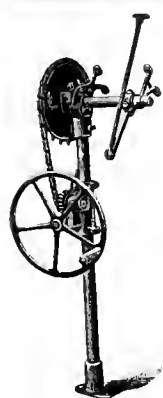

The Advance Ventilating Apparatus

Our line is the latest and best. We have profited by the experience of years of work in this line of work. Our patrons know this. Our improvements make it easy to install, easy to operate and will last a life time. Give us a chance to estimate on your wants. See our new pipe coupling, &c.

The Advance Co.
RICHMOND, IND.

THE FOLEY MFG. CO.

CHICAGO

Completely equipped with up-to-date machinery for the making of material for

GREENHOUSE CONSTRUCTION

From a Full Supply of Thoroughly Seasoned Lumber

Send your sketches to our draughtsmen for completion and suggestion. Permit us to figure your proposed work, large or small.

We guarantee our prices will save you money
FOLEY VENTILATING APPARATUS IS THE BEST

Simple in Erecting. Is Easiest of Operation. It Will Last a Lifetime. Its Price is the Lowest. Will Ventilate Any Size House. Prices and Circulars on Application.

Our 1908 Catalogue Greenhouse Material Sent Postpaid on Request.

THE FOLEY MFG. CO., WESTERN AVENUE
25th and 26th STS., CHICAGO

IRON PIPE

SECOND HAND

WROUGHT IRON PIPE, for Steam, Water, Gas or Oil, Fences or Posts. All Sizes. Price Low.

GEO. B. DOANE & SON
18 Midway Street, BOSTON
Telephone, Main 4419

CYPRESS SASH BARS 32 feet or longer
HOT BED SASH
PECKY CYPRESS BENCH LUMBER

GREENHOUSES

ERECTED AND EQUIPPED COMPLETE IF DESIRED

Write for Circular "D" and Prices

The A. T. STEARNS LUMBER CO.
NEPONSET, BOSTON, MASS.

In ordering goods please add "I saw it in HORTICULTURE."

I. CASSIDY

Designer and Builder of

Iron and Wood Greenhouses

Factory: Summer Ave and Erie R. R.
Newark, N. J.

MASTICA
FOR Greenhouse Glazing
USE IT NOW.
F. O. PIERCE CO.
12 W. Broadway and 227 Greenwich St.
NEW YORK

GREENHOUSE CONSTRUCTION LUMBER

John C. Moninger Co.
117 E. Blackhawk St., CHICAGO

R. TORAWANDA, N. Y.



Evans 20th Century Arm

Will not twist your shafting pipe. Give it a trial and you will use no other. Three times the power of elbow arms.

Write for Catalogue
QUAKER CITY MACHINE CO.
Richmond, Ind.

Holds Glass Firmly
See the Point

FULL SIZE
Nº 2

PEERLESS

Glazing Points are the best. No rights or lefts. Box of 1,000 points 75 cts. postpaid.

HENRY A. BREER,
114 Chestnut St., Philadelphia.

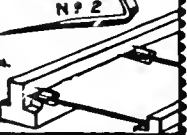

The FLOBISTS' HAIL ASSOCIATION OF AMERICA, insurer of 28,000,000 sq. ft. of glass. For particulars address **John C. Esler, Sec'y, Saddle River, N. J.**

READ! READ! READ!

Every Particle of Heat

is absorbed from the gases in the "Spencer" Heater owing to its superior combustion travel. The numerous tubes passing through the intense heat, split the water up into thin small streams instead of holding it in one large body of water over the crown sheet. These tubes are made of knobbed wrought charcoal iron, the highest price tubes in the market.

The "Spencer" has the most thorough combustion, is the quickest heater and gets more heat out of less coal than any other heater made.

Investigate it before laying in your coal supply and save money.

Send for Catalogue, also ask for our Greenhouse Catalogue "The House of Greatest Sunlight."

WEATHERED COMPANY

P. O. ADDRESS BDX 789, NEW YORK CITY

Of Interest To Gardeners and Superintendents

REALLY complete and satisfactory greenhouse information for private places, institutions and parks, covering not alone construction but valuable points on location, plans, additions, and the innumerable other things you want to refer to so often, has up to the present time been next to impossible to obtain.

To meet just this want of yours, we have published a book called, "Greenhouses As We Build Them," which covers all these points besides many others of interest.

We shall be glad to send you this book with our compliments. Drop us a postal and just mention that you saw the offer in Horticulture.

WE MAKE EVERY PART OF A GREENHOUSE
BUT THE GLASS. WE SELL ANY PART.

LORD & BURNHAM CO.

MAIN SALES OFFICE:

1133 BROADWAY, NEW YORK

BOSTON:
819 Tremont Building

PHILADELPHIA:
1215 Filbert St.

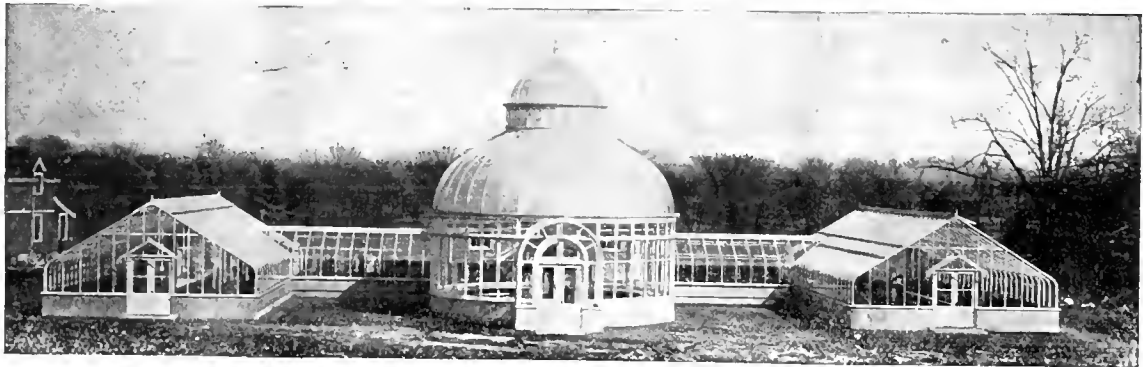

THEY ARE SPEEDILY ERECTED

No complicated structural parts to take extra time, no delays in erecting the frame work, for every member is accurately cut, drilled and fitted for instant erection when it reaches your grounds. They are the simplest, lightest, strongest, most enduring, attractive houses built, and they also cost less to maintain.

SEND FOR CATALOG

The ideal construction for private estates, parks, public institutions and florists' showrooms

U-BAR GREENHOUSES

PIERSON

DESIGNERS AND BUILDERS



U-BAR CO.

1 MADISON AVE. NEW YORK

HORTICULTURE

Vol. VII.

JUNE 13, 1908

No. 24



PEONY DUCHESSE DE NEMOURS (Guerin).

Devoted to the
**FLORIST, PLANTSMAN,
LANDSCAPE GARDENER,**
and
Kindred Interests

Published
EVERY SATURDAY
At 11 Hamilton Place,
BOSTON, MASS.
Subscription, \$1.00

CANNAS

**STARTED PLANTS in 3½ and 4-in. POTS
READY FOR IMMEDIATE PLANTING**

Mme. Nordy, Mlle. Berat, Robert Christie, Golden King, Pennsylvania L. Patry, Florence Vaughan, Pandora, Austria, Rohallion, Pierson's Premier, Queen Charlotte, Frederick Benary, etc.

EXTRA STRONG PLANTS. \$6.00 PER 100

VINCAS AND ENGLISH IVIES

Extra fine plants in ½ and 4 inch pots, for vases, tubs, etc.
\$8.00 per 100; extra size, \$10.00 per 100.

HYDRANGEA OTAKSA

LARGE PLANTS IN TUBS AND HALF-BARRELS FOR JULY AND AUGUST FLOWERING
We make a specialty of these, and have a magnificent lot of large plants, which we can supply in any quantity—
Large plants in tubs, \$4.00 and \$5.00 each. Extra large plants in half-barrels, \$5.00 and \$7.50 each.

NASTURTIUMS. Bushy plants, 3 inch pots, \$6.00 per 100.
SALVIAS, Bon Fire. 2¼ inch pots, \$4.00 per 100.
AGERATUM. 2½ inch pots, \$3.00 per 100.
MOON FLOWERS. ½ inch pots, \$6.00 per 100.
COLEUS, assorted. ½ inch pots, \$3.00 per 100.
ALYSSUM, Tom Thumb. 2½ inch pots, \$3.00 per 100.
CROTONS, for bedding. Extra strong plants, 3½ inch pots, \$25.00 per 100; 5 inch pots, \$50.00 per 100.
ACALYPIA MOSAICA. Extra choice, for bedding, 2½ inch pots, \$6.00 per 100.
PANDANUS VEITCHII. 5 inch pots, \$9.00 per dozen; 6 inch pots, \$12.00 per dozen. Large plants, \$2.00 to \$3.50 each, according to size.
FIGUS ELASTICA. 5 inch pots, \$4.00 per doz; 6 inch pots, \$6.00 per doz.

DRACENA FRAGRANS. Extra large plants, 6 inch pots, 3 feet high, \$12.00 per dozen.
FERNS, assorted. Extra heavy plants, 2¼ inch pots, \$3.00 per 100; 3½ inch pots, extra heavy, \$10.00 per 100.
NEPHROLEPIS PIERSONI ELEGANTISSIMA. 2¼ inch pots, \$6.00 per 100; 3½ inch pots, \$15.00 per 100; 6 inch pots, \$6.00 per dozen; 8 inch pots, \$12.00 per dozen.
BOXWOOD, Pyramida. Extra fine plants, \$2.00 and \$3.00 each.
PANSIES, ENGLISH DAISIES, and FORGET-ME-NOTS. \$3.00 per 100.
CARNATIONS, Winsor and White Enchantress. We can supply these in quantity, ready for immediate planting. Strong established plants from 2¼ inch pots, \$7.50 per 100, \$10.00 per 1000.

F. R. PIERSON CO., Tarrytown-on-Hudson, New York

GERANIUMS

A Large Assortment of the Choicest Kinds.
From 3 1/2 in. pots, \$7.00 and \$8.00 per 100.

HYDRANGEAS

50c to \$5.00 each.

10,000 Tomato Plants

In fine condition. Write for Prices.

WM. W. EDGAR CO.,

Waverley, - - - - - Mass.

Anything of Value

to the profession

CAN BE SOLD

through advertising in

Horticulture

WANTED

400

3 1-2 or 4 inch Gardenias

FOR PLANTING OUT

PRICES TO

KNIGHT & STRUCK

1 Madison Ave., New York City

BAY STATE

The big sensation of all the recent Carnation Shows. A noble flower, white with carmine markings.

Now Booking Orders for Next January Delivery.

Rooted Cuttings, \$12.00 per 100, \$100.00 per 1000

ALBERT ROPER, Tewkesbury, Mass.

JOHN E. HAINES Bethlehem, Pa.

is the place to order rooted-cuttings of the following varieties for 1908.

John E. Haines, red Imperial variegated } Per 100 Per 1000
Pink Imperial, Pink } \$6.00 \$50.00
Enchantress, Light Pink }
Place your orders early for Jan. delivery.

Dracena Indivisa, \$2 and \$5 per doz.
Vinca var. \$1.50 and \$2 per doz.
Canna Robusta, dark leaf, tall from flats, \$3 per C.
Cannas, dark and green leaf, dwarf from flats, \$3 per C.

E. & C. Woodman, Florists, Danvers, Mass.
TELEPHONE, 61-6-2 DANVERS, MASS.

CARNATIONS

F. DORNER & SONS CO.

La Fayette, Ind.

**BEST VARIETIES
Field-grown**

GARNATION PLANTS

CHICAGO CARNATION CO.

A. T. PYFER, MGR. JOLIET, ILL

HYACINTHS, TULIPS, NARCISSI AND OTHER BULBS ROMAN HYACINTHS and the true PAPER WHITE GRANDIFLORA

Ask for our Wholesale Trade List at Hillegom

K. VELTHUYS, Hillegom, Holland
Rep. by FELIX BOSCH, 260 Clarendon St., Boston.

JAPANESE
THE YOKOHAMA NURSERY CO. NEW YORK.
31 BARCLAY STR.
LILIES
PLANTS
BAMBOO STAKES

In writing to Advertisers kindly mention Horticulture

Grab These BARGAINS

Money Trees, best White, 4-in. 10 cents, 2 1/2-in. 5 cents.
Scarlet Sage, **Ulra Bedman** or **Boufire**, 4-in. strong, \$2.00 per 100, \$45.00 per 1000.
Clematis Jackmanni, late fall importation, 4 ft. high, nicely staked up, 35 to 40c.
Araucaria Excelsa Glauca, 6 to 7-in. pots, last spring (1907) importation, 3 tiers, 25 to 40 inches high, same in width, 2 year old, suitable for lawns and porches, \$1.75, \$2.00, \$2.50, \$3.00, \$4.00 each. Imported two weeks ago 5000 **Araucaria Excelsa**, 3 tiers, 6-8-10 in. high, 40c; 10-12-14-in., 50c, 60c, 75c, \$1.00 each.
Kentia Belmoreana, 6-in., 75c, \$1.00, \$1.25, \$2.00, 2 1/2-in., 20-25 inches high, 50c, 60c, 4 in., 75c. **Forsteriana**, large plants, \$2.50 each, 7-in., 40-50 inches high, \$3.00.
Bay Trees, just arrived from Europe, Standard, 8-ft. high from top of tub, crown 30 inches in diameter, per pr., \$15.00.

Cash with order, please. All goods must travel at purchaser's risk

Godfrey Aschmann
 Importer, Wholesale Grower and Shipper of Pot Plants
 1012 West Ontario St. Philadelphia, Pa.

American Beauties, 3 in. \$8.00 per 100
 " " 4 in. 12.00 " " "
Asparagus Plumosus, 2 in. \$2.50 per 100;
 \$20.00 per 7.
Asparagus Plumosus, seedlings, \$1.00 per 100;
 \$8.00 per 7.
Asparagus Plumosus, large heavy clumps from Bed. \$10.00 per 100.
Asparagus Sprengeri, 2 in. \$2.00 per 100;
 \$17.50 per 7.
Asparagus Sprengeri, 3 1/2 in. \$6.00 per 100
Vincas Varig. 2 1/2 in. extra strong plants, \$4.00 per 100
Vincas Varig. 3 and 4 in. \$7.00 per 100

ALL ARE EXTRA FINE STRONG PLANTS.
 TERMS: 3 IF CASH WITH ORDER.

ERIE FLORAL CO.,
 ERIE, PA.

Hardy Rhododendrons Azaleas Conifers, Clematis, H. P. Roses, Shrubs and Herbaceous Plants from our HOLLAND NURSERIES

Prices Moderate
P. OUWERKERK, 216 Jane St., Weehawken Heights, N. J.
 P. O. No. 1, Hoboken, N. J.

FERNS

Assorted for JARDINIERS
 Strong, healthy plants 2 1/2 inch pots, \$3.00 per 100, \$25.00 per 1000; 500 at 1000 rate. 3 inch, \$6.00 per 100.

FRANK N. ESKESEN, MADISON, N. J.

In ordering goods please add "I saw it in HORTICULTURE."

ROBERT CRAIG CO.
 ROSES, PALMS,
 and Novelties in Decorative Plants
 MARKET and 49th STREETS., PHILADELPHIA, PA.

PALMS Home Grown.

KENTIA BELMOREANA

	Each	Doz.
6-10. pot, 6 to 7 leaves, 22 to 24 in.	\$1.00	\$12.00
6-in. pot, 7 to 7 leaves, 24 to 26 in.	1.25	15.00
6-in. pot, 6 to 7 leaves, 26 to 28 in.	1.50	18.00
6-in. pot, 6 to 7 leaves, 30 to 36 in.	2.00	24.00
7-in. pot, 6 to 7 leaves, 32 to 34 in.		
Leavy	2.50	30.00

COCOS WEDDELIANA

2 1/2 in. pot, 8 to 10 in. high	10 cents each
2 1/2 in. pot, 10 to 12 in. high	15 cents each

A FULL LINE OF KENTIAS

All Sizes) READY IN JULY

JOSEPH HEACOCK COMPANY, Wyncote, Pa.

RHODODENDRONS, ANDROMEDAS, KALMIAS AND SPECIMEN EVERGREENS

JOHN WATERER & SONS, LD.

AMERICAN NURSERY

BAGSHOT, - - - ENGLAND

FINEST LOT OF

HARDY HYBRID RHODODENDRONS

ALSO DWARF RHODODENDRONS

ANDROMEDA FLORIBUNDA

READY FOR IMMEDIATE SHIPMENT

ORDER TODAY

EASTERN NURSERIES, JAMAICA PLAIN, MASS.

HARDY NORTHERN GROWN NURSERY STOCK

At Reasonable Prices

FRUIT AND ORNAMENTAL TREES, SHRUBS, VINES, ROSES AND HERBACEOUS PERENNIALS IN GREAT VARIETY

Catalogue and Price List for the asking

BAY STATE NURSERIES, NORTH ABINGTON, MASS.

The Roses that Win

MRS. POTTER PALMER, CARDINAL American Beauty and Other Standard Varieties. Rooted from Our Famous Stock. Send for Prices.

POEHLMANN BROS. CO.
 Morton Grove, Ill.

ROSES

A SPECIALTY

The Dingee & Conard Co. West Grove PA.

RHEA REID

READY NOW, Own Root, \$30 per 100, Grafted, \$35 per 100.

AMERICAN BEAUTY

Fine Young Stock, \$6 per 100, \$50 per 1000.

THE E. G. HILL CO., Richmond, Ind.

AMERICAN NURSERY CO., COMBIN- ING

FRED'K W. KELSEY, New York City
 F. & F. NURSERIES, Springfield, N. J.
 BLOODGOOD NURSERIES, Flushing, L.I.
 N. J. & L. I. NURSERIES

We can supply your every need. Write for prices
Sales Department

150 BROADWAY, - NEW YORK

In writing to Advertisers kindly mention Horticulture

Notes from the Arnold Arboretum

The Rhododendrons are now in full bloom and the group at the foot of the Hemlock Hill presents a beautiful picture. A few of the earliest have already dropped their flowers and the latest are just starting to bloom, while the great mass is in its prime. As there have been often published lists arranged according to the color of the flowers, but not according to the time of flowering, which is certainly a point also to be taken into consideration in forming effective groups of Rhododendrons, the following lists attempts to give an arrangement according to the time of flowering, beginning with those which are already out of bloom: *Coriacum*, *Lady Armstrong*, *Prometheus*, *Alosanguineum*, *Kettle drum*, *R. S. Field*, *Smicrorhiz*, *Charles Dickens*, *Everestianum*, *James Macintosh*, *Purpureum crispum*, *Mrs. H. S. Hannerwell*, *Caracacus*, *Alexander Dancer*, *Roscum elegans*, *Edward S. Rand*, *Mrs. Hardy Ingersoll*, *Charles S. Sargent*, *Hannibal*, *F. L. Ames*, *Purpureum elegans*, *Roscum elegans*, *Milton*, *Lady Gray Egerton*, *F. D. Codman*, *Henrietta Sargent*, *Album elegans*, *Album grandiflorum*, *Charles Thorold*, *Delicatissimum*, *H. W. Sargent*.

The native *Rhododendron calendulaceum* is now very beautiful with its rich flame-red or orange-red and orange-yellow flower and is hardly surpassed by any of the Ghent Azaleas with flowers ranging in color from pure white to deep crimson. They are chiefly hybrids of *Rhododendron flavum* (*Azalea pontica*) and the American species, partly also with an infusion of *Rhododendron sinense* (*R. molle*). The following is a list of the best now in bloom arranged according to colors. White: *Auguste Mechelyuk*, *Mme. M. Singer*, *Daviesii*, *Souvenir de Louis van Honth*; yellow: *Anthony Koster*, *J. A. Koster*, *Nancy Waterer*, *Gaelder Rose*; pink: *General Trauff*, *Aurora de Ronghom*, *Jan van Tol*, *Grandeur triomphant*, *Mme. Moser*, *Julius Caesar*, *Queen Victoria*, *Cardinal*; red, crimson or purple: *Ghent des bahilles*, *Comte de Flandre*, *Agneurnora*, *Roi des Belges*, *Fania* and *Beauz*; unique with deep crimson flowers, one of the darkest.

A shrub of striking beauty is the Golden Chain with its drooping racemes of golden yellow flowers: it seems to have fallen somewhat in disfavor because *Laburnum vulgare*, the species commonly planted is not perfectly hardy in this section of the country, but there is another species, *L. alpinum*, which has proved much hardier and is equally handsome. The individual flowers are somewhat smaller, but the racemes are usually longer and the lustrous foliage is even prettier: its habit is more upright and it grows in its native country into a small tree up to 30 feet in height, but remains more often shrubby. Another very effective Leguminous shrub is *Cytisus scoparius*, the Scotch Broom, now covered with its large golden yellow flowers: it is well suited for planting on sandy dry slopes, but is apt

to suffer in severe winters: it has become naturalized at several places, particularly along the coast.

Syringa villosa and *S. Josikaea* are now the only Lilaes in bloom: both are closely related and very similar. The former grows into a broad and bushy shrub and produces its rather dense panicle of pale pink flowers in great profusion, while *S. Josikaea* is a slenderer shrub with violet narrower and looser panicles. Particularly *S. villosa* (*S. Bretschneideri*) is to be recommended for its good habit and profusion of flowers.

Some of the Mock Oranges are now in bloom: the earliest is *Philadelphus hirsutus*, a native species, but less ornamental than most other kinds on account of its smaller and scentless flowers: this is followed by the popular strongly scented *P. coronarius* and by two less known species from eastern Siberia, *P. tenuifolius* and *P. Schrenkii*, with only slightly fragrant flowers of a purer white color. Among the handsomest Mock Oranges are certainly the numerous forms derived from *P. Lemouinei*, of which the exceedingly pretty *Boule de neige* and *Manteau d'hermine* are the first to bloom: both are low, graceful shrubs with their slender branches curving under the weight of comparatively small double flowers exhaling a delicate perfume.

One of the last of the Bush Honeysuckles to flower and one of the finest is *Lonicera Maackii* which grows into a rather tall shrub with the spreading branches densely covered with rather large white, slightly fragrant flowers: it is a native of eastern Asia and has proved perfectly hardy, but is still little known, though it certainly deserves a place in ornamental shrubberies. While this species is in bloom, *Lonicera gracilipes* and *L. canadensis* (*L. ciliata*) show already their handsome scarlet berries.

The many varieties of *Dicrilla* are now in full bloom exhibiting a profusion of flowers mostly in different shades of pink and carmine, one of the most beautiful of the pink varieties being *Abel Carriere*: a handsome pure white variety is *Dame Blanche*, while one of the darkest is *D. floribunda* var. *Lowei*, but the darkest of all and one of the latest to bloom is *Eva Rathke*.

Several species of the wild Roses are showing their flowers. One of the most beautiful is the *Rosa rugosa* with its large purple flowers and its handsome foliage, of which there is also a variety with double flowers and one with pure white flowers. Of *Rosa spinosissima* which forms a low shrub with very small foliage, the var. *albaica* with rather large flowers, is one of the prettiest. One of the earliest among the native species is *Rosa blanda* which now brightens up the borders of shrubberies with its pink flowers.

Alfred Rehder.

Our Cover Illustration

Peonies fill the public eye at present and the present week finds them in full glory from the latitude of Philadelphia north to Buffalo. The variety *Duchesse de Nemours* (Guérin), which forms the subject of our cover illustration, is one of the finest of the pinks a sturdy growing, free flowering, effective flower. There is another *Duchesse de Nemours* in the market raised by Calot, which is white.

HORTICULTURE

VOL. VII

JUNE 13, 1908

NO. 24

PUBLISHED WEEKLY BY
HORTICULTURE PUBLISHING CO.
 11 Hamilton Place, Boston, Mass.

Telephone, Oxford 292
 WM. J. STEWART, Editor and Manager

SUBSCRIPTION PRICE

One Year, in advance, \$1.00; To Foreign Countries, 2.00; To Canada, \$1.50

ADVERTISING RATES

Per Inch, 30 inches to page \$1.00.
 Discounts on Contracts for consecutive insertions, as follows:
 One month (4 times) 5 per cent.; three months (13 times) 10 per cent.;
 six months (26 times) 20 per cent.; one year (52 times) 30 per cent.
 Page and half page spaces, special rates on application.

Entered as second-class matter December 8, 1904, at the Post Office at Boston, Mass. under the Act of Congress of March 3, 1879.

CONTENTS

	Page
COVER ILLUSTRATION—Peony Duchesse de Nemours	
NOTES FROM THE ARNOLE ARBRETUM—Alfred Rehder	781
PEONY DUCHESSE DE NEMOURS	781
BRITISH HORTICULTURE—W. H. Adsett	783
SUPERFLUOUS BULB FLOWERS August Boehmann	783
AMERICAN ASSOCIATION OF NURSERYMEN:	
Opening Session—President's Address	784
Secretary, Treasurer and Committee Reports—Afternoon Session	789
Thursday Sessions	787
THE FEMPLE SHOW—Edgar Elvin—Illustrated	787
NEWS OF THE CLUBS AND SOCIETIES:	
New Jersey Floricultural Society—Retail Florist Association—New York Florists' Club—Meetings Next Week—Florists' Club of Washington—American Apple Growers' Association—Albany Florists' Club—Chicago Florists' Club	788
Horticultural Society of New York—Rhododendron Show at Boston—Society of American Florists—Missouri State Board of Agriculture Club and Society Notes	789
DURING RECESS	789
OBITUARY—James Shanley, Portrait—Mrs. Jerome Jones—Robert B. Graves, Portrait—George Roy, Portrait—George H. Linsdale, Portrait	790
SEED TRADE	793
FLOWER MARKET REPORTS:	
Boston, Chicago, Detroit, New York, Philadelphia, Washington	797
MISCELLANEOUS:	
Longiflorus vs. Multiflorus	787
Frimula obcordata as a Bedding Plant	787
New Notes	791-792
Propagation of Scandopitys verticillata	791
A Notable Society Fete	792
Spring Plant Trade in Chicago	792
Incorporated	792
Missouri Botanical Garden	792
Business Changes	794
New Retail Flower Stores	794
Steamer Departures	794
Personal	795
Philadelphia Notes	797
Crownlenses Building or Contemplated	801
List of Patents	805

class interests to continue to suffer as they have, in increasing degree during recent years, through lack of organization and co-operation according to modern business custom. The primitive policy of "every man for himself" has been a serious obstacle to the progress commercially of the flower business. The growing of flowers has made phenomenal advancement as compared with other interests because growers have been disposed to meet and discuss freely on topics of mutual concern. It is refreshing to see at last, that others are coming to realize their great need and that men who have been deaf hitherto to any and all appeal for their support of organizations existing for the express purpose of helping the individual through the strength of union, are now beginning to see a new light. But while HORTICULTURE is and always has been a consistent believer in a multiplicity of societies, we do feel that as much harm as good may come from movements within the profession which tend to isolate interests which are interdependent and to aggravate any distrust which may already exist between the different sections. Segregation of this sort is certain to be detrimental to the best growth and development of the business as a whole and any policy which tends in that direction has in it elements of far-reaching mischief.

In most cases where a new organization is started in the same field in which a like body already exists it may be

argued with some show of reason that neglect on the part of the older body to properly fulfil its legitimate mission makes it responsible for the disaffections thus crystallized. Unfortunately, wise diplomacy is not an overabundant quality in the councils of any association, particularly if it be a strong one, and statesmen, even in Congress as we have good reason to know are not easily found when most needed but that all reasonable and available means for conciliation and the establishment of harmonious co-operation between closely related interests should be exhausted before any step is taken which may tend to split the profession into factions and array one section against another is a proposition that should appeal to every intelligent man. It must be plain to all who stop to consider the situation that the horticultural industries as they exist today are only a fraction in extent and commercial importance as compared with what they are destined to rapidly grow to, and this without regard to any slight set-back that may have been sustained through the influence of the recent financial disturbances. We are surely getting ready for a great development all along the line in the near future and it is a first duty to ourselves individually and to our profession in its broadest definition, to get together wherever, however and whenever we can for the purpose of building up and cementing together with the strongest ties possible all departments of the industry. What the business now needs more than anything else are better business methods and closer cohesion between individuals and between all departments. "Let us reason *together*."

Evidence is not lacking to indicate that the flower trade people are donning their thinking caps and that a strong sentiment exists in the ranks of the growers, wholesale dealers and retailers against allowing their several

Co-operative sentiment should be encouraged

British Horticulture

THE TEMPLE SHOW.

The absorbing event of the week has been the great show of the Royal Horticultural Society in the old-world Temple Gardens, in the centre of the busy metropolis. The best which can be produced by leading specialists in all branches of the floral art was brought together to form the finest horticultural display which is seen in this country. It was a cosmopolitan crowd one encountered in the congested tents. Here one rubbed shoulders with the owners of priceless orchids, as well as the leading British nurserymen and amateurs, who were augmented by florists from France, Belgium and Germany and by growers from the leading bulb centres in Holland. Visitors who had attended the recent Ghent exhibition were able to make comparisons. It was generally admitted that the quality of the exhibit could not be surpassed but there seemed to be a consensus of opinion that the Ghent exhibition was superior as regards the originality and effectiveness of the displays. There is something stereotyped and conventional in the methods adopted in arranging the groups and collections. The exigencies of the site were in some measure responsible for this. Although splendidly situated as regards convenience of access, the Temple Gardens in the midst of the seat of legal learning, are restricted in area. The Society has to exercise economy in allotting space to the 125 exhibitors, and even then it is impossible to comply with all the demands. A large amount of space was devoted to the orchids, the treasures of the leading orchidists being on view. The Veitchian gold cup was awarded in this section, this being taken by Mr. F. Monteith Ogilvie. Messrs. Sander & Sons had a pleasing arrangement of orchids intermixed with graceful ferns.

Roses were, of course, to the front and formed a magnetic attraction to countless admirers. The old favorites were well represented. Mr. G. Mount, of Canterbury, showed Joseph Lowe, a new H. T., which is a sport from Mrs. W. J. Grant. English and Channel Island growers of carnations vied with one another in the splendor of their displays; the American introductions being well to the fore. Rhododendrons and azaleas added a wealth of color to the show. A grand selection was sent by the noted firm of John Waterer & Sons, Ltd., of Bagshot, Surrey, whose productions are well known on both sides of the Atlantic. Pink Pearl was seen at its best, the other varieties comprising Marquis of Waterford, Francis B. Hayes, Gomer Waterer, Mrs. Holford, etc. The whole collection was of a very meritorious character and well deserved the silver cup awarded. A notable exhibit was the group of extra fine hippeastrums shown by Messrs. R. P. Ker & Sons, of Liverpool, the plants being very effectively arranged. Fruits and vegetables formed a somewhat small section.

SOME NEW INTRODUCTIONS.

In the orchid section first class certificates were given to the undermentioned exhibits:—*Laelio-Cattleya* Elva Westonbirt variety, shown by Major G. L. Holford, Westonbirt; *Cattleya Mendelli* His Majesty, shown by Mr. Francis Wellesley, Woking; *Odontioda Charlesworthii*, shown by Charlesworth & Co.; *Odontoglossum illustre* luxurians, and *O. eximium* Queen Alexandra, shown by M. Chas. Vuytstake, Ghent; *Cypripedium ventricosum*, shown by W. Cutbush and Son. A striking new dracaena (D. Bonetti var. De Grooti) shown by Veitch & Co., gained a first-class certificate. This has long, narrow leaves, margined and striped

with yellow, with a red mid-rib. A golden-orange May-flowering tulip, Walter T. Ware, shown by Mr. Walter T. Ware, and Barr & Sons, awarded a first-class certificate. In addition awards of merit were granted to the undermentioned exhibits: R. and G. Cutbush showed *Azalea occidentalis graciosa*, with white blooms and blotchings of yellow on the upper petals. Begonias were displayed in profusion by Blackmore and Langdon, amongst them being Empress Marie, a graceful white bloom of the tuberous-rooting section. Codium (Croton) Fred Sander, who was included in Sander & Sons' group at Ghent, is a valuable addition to this section. The leaves of the handsome plant are golden yellow in the upper half and bright green in the lower part. There were three rose novelties. Rose Elaine, shown by W. Paul and Sons, is a dwarf habited H. T., white with a faint trace of rose. White Dorothy, is a sport of the well-known Dorothy Perkins, this being seen in the exhibit of Paul & Son, and A. Cant & Sons. *Dimorphotheca aurantiaca* is an introduction from the Cape which Barr & Sons are distributing. This is of an orange-gold hue, with a dark-tinted disc. Tulips were displayed in all their grandeur by Alex. M. Wilson, the most notable being Duchess of Westminster, a shapely rose-colored Darwin variety. G. Wallace & Co. showed *Paeonia decorata* alba, of a pleasing form and tint. These are but a sample of the many interesting exhibits. To give a complete list would fill the pages of a week's issue of HORTICULTURE.

W. H. Adsett.

Superfluous Bulb Flowers

Editor HORTICULTURE:—

I noticed your editorial in your issue of April 18, referring to Dutch bulbs as a superfluous commodity in the cut flower market. You certainly express the situation pretty clearly and I heartily endorse those sentiments.

No doubt Dutch bulbs have a place in gardens and in pots and pans, but as cut flowers they are no longer a necessity but a detriment to the general florist business except to a few who find good use for them in design work, etc.

From a grower's standpoint, the primary fact for you to consider is how does the cut product of bulbs affect the sale of his own grown products. Why not foster home productions? Look at the grand varieties of roses and carnations, for instance, which we now have in abundance to take the place of cut bulbous blooms.

Times have changed. It goes without question that one-third of the Dutch bulbs forced during the season 1907 to 1908 would have netted a larger profit than was realized on the total, showing conclusively that something is radically wrong. The quicker it is righted the better for everyone in the business.

Yours truly,

Aug. Palmers

Chicago.

AMERICAN ASSOCIATION OF NURSERYMEN

Great Convention at Milwaukee, Wis.—Rochester, N. Y. Chosen as Next Meeting Place—Charles J. Brown of Brown Bros., Rochester, N. Y., Elected President.

The third annual convention of the American Association of Nurserymen was a great success, some three hundred being in attendance. The wind was off the lake and weather very chilly though sunny.

OPENING SESSION.

The meeting was called to order at 9:30 by President Hill, introducing Mayor David S. Rose, who spoke of Milwaukee as a most beautiful home city and the best convention place in the Union. It is a city of lowest percentage of crime of any great city, also lowest percentage of drunkenness, and only one city surpasses it in the percentage of people owning their homes. It also has the lowest mortality of any large city. He spoke at length of the efforts to beautify the city by parks and lawn spaces throughout the streets, and ended by welcoming the city's guests.

Response was made by Geo. S. Joselyn, who was humorously introduced to the audience by President Hill. His sallies of wit kept the audience in good humor and at times he was interrupted by roars of laughter.

He was followed by President C. W. Hill, who delivered his annual address, which was listened to in silence and fondly applauded at its close. The president was followed by Secretary Sager, who in a short report spoke of the work of his office and was followed by Treasurer Yates.

PRESIDENT HILL'S ADDRESS.

Gentlemen of the American Association of Nurserymen:

Another cycle of three hundred and sixty-five days has passed since we bade each other farewell in Detroit at the close of one of the most interesting and profitable meetings of this Association, and today we stand upon the threshold of the 34th year of our existence.

The Association.

Little did the few faithful men who met a third of a century ago realize the scope, magnitude, influence and glory of the organization on which they at that time brought into existence. The character of the Association since that time has been varied. Its path way has not always led through rose beds and flowers, but indeed more frequently over the stony and hard places of existence, the latter of which has given to it stability, influence and importance, and today it is regarded as the most complete organization of the best men on the American continent, men whose lives are wholly devoted to that noble vocation which has for its object the betterment and uplifting of mankind.

for what class of men does more toward beautifying the home and providing for its occupants, the luscious and healthful fruits of the orchard, vineyard and garden.

If I could with a single wand wipe from the face of this beautiful land of ours, all the effects, benefits and beauties heretofore produced by the nurserymen, what a desolate, forlorn and distressing picture would be presented to you. You can scarcely conceive of a greater calamity. The members of this Association have contributed largely to the existing condition of affairs as we see them today and each one should feel justly proud of his high vocation.

There are represented in our membership the leading men of this country: judges, lawyers, legislators, bankers, congressmen, mayors, doctors and others, who find time to devote to the delightful occupation of the horticulturist and nurseryman. Few of us likely realize the magnitude to which this business has attained. There are today invested in the nursery business of the United States more than sixty millions of dollars, and employment given to about fifty-five thousand men and three thousand women. The use of 18,300 horses and mules is required to cultivate a little over 200,000 acres of land, upon which are annually reproduced 4,200,000,000 plants and shrubs, and 622,000,000 trees. Thus you can imagine something of the importance of this organization of business men.

Absent Members.

Upon looking over the audience, our hearts are made sad, for we miss the familiar faces of some whom it has been our pleasure to meet annually for more than a score of years. The great reaper with his sickle has made inroads upon our Association during the past year and removed from us some of our best-known members and wisest councillors. They now peacefully sleep upon the hillside amid the flowers they loved so well, and know not if the day or night, know not if the birds shall sing and the flowers bloom, or if the storms shall rage, and over their graves, unheeded drift the winter's snow. They are gone from among us for ever, but the membership of this organization will ever hold in fond remembrance their valued service and wise counsel, and your President would recommend the appointment of a special committee to draft suitable resolutions to be presented at a later session of this convention.

The Panic.

During the past year, we, like all

other business men of the country, were brought face to face with a financial depression which resulted in what ex-Secretary Shaw claims to be "the worst panic the world has ever known." This condition of affairs arose last fall at the time the retail nurseryman was making his shipments, and in many places poor deliveries were made, or clearing house certificates, notes and other evidences of indebtedness were taken in payment for trees, but with the readjustment of affairs, these have been promptly met. Congress has just passed the compromise currency bill, and we are now, I trust, over the roughest places, with nobody badly hurt.

The Past Year.

The season just closed is generally regarded as one of the best we have had for many years. All stock, with the possible exception of Kieffer pears and some varieties of plums, have commanded unusually strong prices, and stocks were well cleaned up. In consequence of this, I am inclined to think every man here today is happy, and I see no reason why we should not have an enjoyable and profitable convention.

The present conditions of the affairs of the Association, with a membership of more than four hundred and annual receipts about three thousand, are in the whole, quite satisfactory. Some aggressive action however, is needed along certain lines, which I think would inure to our best interests and which I shall mention a little later.

As far as I am able to learn, the outlook for future business is good with such indications as to justify us in thinking that the present satisfactory wholesale prices will be maintained, but the practice of our wholesale men in placing surplus stock on the market late in the season, at greatly reduced prices, I think is demoralizing and should be discontinued.

I am inclined to the opinion, however, that the retail nurserymen who constitute a large portion of the membership of this Association, are not getting from the planter prices commensurate with the total cost of stock handled. These prices should be advanced and can be gradually brought about by handling only first-class trees of the grades specified and consigning the inferior stock to the brush pile rather than disposing of it to department stores and unreliable mail-order concerns, which dump it on the market at ridiculously low prices, in competition with dealers of first-class trees. Tell your customer the truth, furnish him first-class

stock, charge him good prices for it, and you will soon find him taking care of it and willing to pay you the right prices for good trees.

Inspection Law.

The kindest feeling exists between the American Association of Nurserymen and the organization of Economic Entomologists and Horticultural Inspectors, as was manifested by the hearty co-operation of committees from these societies with that from our Association at Chicago last winter. The report of ex-President Orlando Harrison, chairman of Committee on Uniform Inspection Law, will no doubt set forth the resolutions unanimously agreed upon by these organizations, which were to be the basis of the proposed Uniform Inspection Law. It was greatly desired that this proposed bill be introduced and be made a law by the session of Congress which has just adjourned, but Mr. Harrison deemed it not advisable to present it at that session.

I am personally of the opinion that the enactment of the law proposed would do much to obviate the many vexatious and annoying conditions which arise under the present situation, and advise that it be vigorously pushed by this or a similar committee before the next session of Congress or else the matter be dropped entirely and further expense avoided.

Transportation Committee.

We cannot over-estimate the importance of the transportation committee, and while nothing requiring special attention has occurred during the past year, yet I am inclined to think there may be much to look after in the near future. A recent movement on the part of the railroads has been inaugurated for the advance of freight rates. The Industrial Traffic League at its meeting in Chicago a short time since, carefully considered the matter from the standpoint of large shippers, and it was estimated that the proposed increase would aggregate the enormous sum of \$17,000,000 annually. If the proposed advance is permitted, the nurserymen will, of course, have to bear his share of the additional burden.

The adoption by the Western Classification Association of what is known as "Rule 4," by which Western railroads are to be released from liability for loss or damage to goods in transit, unless 20 per cent, is added to the tariff rates, is one which if enforced will result in a great hardship upon the members of this Association. This rule, I am informed, became effective on May 20th, but one of the leading western roads notified the Interstate Commerce Commission of its refusal to concur therein. Mr. Stannard, chairman of the Transportation Committee, inaugurated a plan by which I think the remaining roads may be induced to regard the matter in the same light. Your committee in this and all other matters should receive your hearty co-operation, and every nurseryman should respond promptly to suggestions made by it. I feel that the chairman of this committee should have an emergency fund placed at his disposal to permit his attending the meetings of the classification committees whenever matters

of importance are liable to come up in which we are interested.

Legislative Department.

In this department some good results have been accomplished during the past year in the modification of the South Dakota law, as you will learn from the report of Mr. Titkin, chairman of that committee. The states of Wisconsin and Wyoming, however, have enacted unreasonable laws which have given members of this Association much annoyance and unnecessary expense during the past year. I am advised that the Secretary of Agriculture in one of these states has been unusually arrogant and overbearing in his dealings with outside nurserymen making shipments within his territory during the past season.

I recommend that the proper committee be authorized to investigate as to the constitutionality of the laws in these states and Oklahoma, and proceed at once to test the same with the least possible delay. It has been suggested that the Executive Committee be given discretionary power to appropriate funds and to proceed through the Legislative or through their own committee to test these or any other laws which in their judgment are a menace to the interests of the nurseryman. I shall be pleased to have you give this matter your consideration, thus avoiding unnecessary delay on account of no appropriation of funds, except for specified cases, which confronted your committee during the past year.

I personally wrote the various vice-presidents this year, requesting that they keep a sharp lookout for proposed adverse legislation in their respective states during the sessions of their general assemblies last winter, and promptly report same to the legislative committee. Few of the states held any session last year, but I urge upon these gentlemen the great importance of watching this matter during the coming winter. The passage of many of these laws can be prevented if proper action be taken beforehand.

Advertising.

I want to repeat, with greater emphasis if possible, what my predecessor stated at our last session regarding the necessity of giving greater publicity to our products through the medium of newspaper advertising. We are living in the greatest advertising age the country has ever known, as may be easily ascertained by closely examining the columns of our leading papers and magazines. The live, up-to-date nurseryman can ill afford to listlessly follow in beaten paths because they led his father to success, or to continue the methods that he himself even adopted ten years ago. We must adapt ourselves to new methods and the changed conditions brought about by this era of advertising.

Select some good advertising mediums, which publish the truth, and which have the confidence of their readers; send them honest, truthful ads, and let them know what you have to offer.

Furnish your customer just what you agree to furnish, thus upholding the respectability and truthfulness of the journal or magazine, and at the same time realize the consciousness of having treated your patron right, and

just as you stated you would in your advertisement.

Honesty and truthfulness in advertising is the only policy which will endure.

Exhibits.

I desire in this connection to especially call your attention to that feature of our convention known as "Exhibits" under the skillful management of Mr. Meehan of Pennsylvania, Mr. Earnard of Kansas and Mr. Kelsey of New York. This feature of our annual meeting has been developed until it has become one of the most interesting departments of the Association work. You will find here not only a display of nursery stock, fruits, flowers, etc., which will interest you, but machinery and labor-saving devices which will appeal to every "wide-awake, up-to-date" nurseryman in attendance. It has required the expenditure of much time and labor on the part of the gentlemen which is greatly appreciated. The exhibition rooms are located on the floor below and in an adjoining room on this floor, in which you can spend much of your time with profit to yourselves.

Insurance.

The question of mutual insurance among the members of this Association has been given much thought and investigation by the committee to which it was referred last June at Detroit.

On account of the varied exposure in the different plants and the constantly changing contents of the buildings, it would necessitate a personal examination by a representative of the insurance department. And on account of the widely scattered patronage which must necessarily be secured, it would be almost impossible for this personal examination to be made without great expense, hence this proposition is deemed impracticable, and we recommend that it be dropped for the present.

Editing Annual Report.

I recommend that the task of editing the minutes of the Association be placed in the hands of a committee of which the Secretary of the Association shall be chairman.

My reasons for so doing are from the simple fact that he is always present at each session of the convention, and knows more about the proceeding than any other member. In the second place he is compensated for his services, and in my judgment this is a part of his work. He can take a portion of his manuscript and edit it at his leisure, thus saving time in completing the work, with the result that the reports will be mailed to the members upon a much earlier date.

Program.

You will note by the printed program in the Pledge Book that arrangements have been made to hold but one business session of the Association proper, each day. The thought being that a session of nine o'clock to one daily would be more largely attended and prove more interesting than more frequent daily meetings. This will give the members an opportunity of spending more time in a social way, sight-seeing, in the exhibition room, etc.

This will give more time also for holding the annual meetings of associate or-

ganizations to which most of us belong, if it is desired, however, to hold an afternoon or evening session, the Program Committee will gladly consider your wishes in the matter.

National Council of Horticulture.

No one regrets more than I that through an oversight the call for a report from Mr. Maloy, Chairman of the Committee on National Council of Horticulture, was omitted from the printed program.

Indeed, I am personally more responsible for this than anyone else, but am pleased to state that a correction in the program has been made and Mr. Maloy's report will be forthcoming.

Forest Preserve.

The subject of Forest Preservation is one of the most important questions confronting the people of the United States today and one in which we as nurserymen should be vitally interested. If the ruthless devastation of our forests, coupled with the natural demands for lumber and railroad ties, is continued, we shall within another decade be confronted by a very grave problem.

We are forest builders and should give every encouragement possible to forest preservation.

There is a branch of the Department of Agriculture formerly known as the "Bureau of Forestry," but now called "Forest Service," under the direction of the Secretary of Agriculture and of which Hon. Gifford Pinchot is the head, which stands ready to co-operate with the different states, organizations or individuals whose object is the planting or preservation of forests.

In addition to this some of the states have enacted laws for the preservation of their forests and for the encouragement of forest tree planting, but there are many other states largely in the middle west and south, which have taken no action whatever in the matter, and it has suggested itself to me that we as an association should delegate to our various Vice-Presidents the duty of investigating, arousing interest, and if possible bring about the enactment of laws along this line, in their states.

I am inclined to think that it might be well to have a "Forest Preserve Committee," or a "Forestry Committee," whose duty it shall be to co-operate with the "National Forest Service" as well as the individuals having the matter in charge in the respective states, and render every assistance possible to bring about the desired result.

Committees.

All committees the past year have performed faithful and efficient work, and I desire to take this opportunity of expressing my appreciation of the same.

And finally, friends, I entertain the hope that the thirty-third annual meeting of this Association may be one of profit and pleasure. I know something of the vexatious and annoying things with which you have to contend during the year and it is well that you take a few days off about this time every summer and meet your fellow nurserymen and old friends who will buoy you up and send you back home much better fitted by having attended the meeting.

SECRETARY'S REPORT.

The president was followed by

Secretary Seager, who in a short report spoke of the work of his office and was followed by Treasurer Yates.

THE TREASURER'S REPORT.

The report of Treasurer Yates showed receipts for the year to be \$2905.22 and disbursements \$3309.20, leaving a balance in the treasury at the present time of \$2913.27.

COMMITTEE REPORTS.

Irving Kouse reported that as Congress had taken no action on the tariff his committee had found no occupation but were prepared for more work at the next session.

Wm. Pitkin reported that the main work of the committee on legislation had been with South Dakota laws as instructed at the Detroit meeting. The litigation was successful and nurserymen can now do business in that state by filing inspection certificate of their own state and paying a moderate license. Attention was also called to the illegal features of the laws of Wisconsin, Wyoming and Oklahoma, but no action had been taken. The committee feels that the laws can be defeated in these states and it would be wise to undertake it.

The report of C. L. Watrous on entomology led to a lengthy discussion which was joined in by several members of the National Society of Entomologists. The resolutions were read which had been passed by this society in relation to safeguarding this country against insect pests or plant diseases in imported plants, and also to have Congress empower the Secretary of Agriculture to stamp out such pests when introduced and threatening to become dangerous or migratory. Also in resolutions looking to uniform inspection of nursery stock for interstate shipment.

Orlando Harrison's report on national inspection law followed. He had asked for the opinion of eighty leading nurserymen by mail and read extracts from answers received, most of them favoring a national law and national inspection of nurseries. The question as stated by Mr. Harrison is, "Who is to be supreme, the state or nation?" States prove very jealous of their rights, and he thinks the attainment of uniformity is hopeless. He recommended that some definite system be established for inspecting imported goods, but aside from that advised dropping the subject or as C. L. Watrous put it, "Bury and forget to erect a headstone." A lively discussion followed, joined in by many members and also by Prof. Symonds of Maryland and Prof. Burgess of Washington, formerly of Ohio. Prof. Symonds recommended inspection of imported stock at point of delivery, and thought arrangements to do this could be made with the state authorities. Some of the members, notably Mr. Kirkpatrick of Texas, opposed inspection of imported nursery stock when the pests were liable to be introduced as readily in hay, fruit or by other means, or even by scientists, as witness the gypsy moth. It was unanimously voted to dispense with further action looking to a national inspection law.

Thos. W. Meehan reported on the exhibits, thanking the exhibitors for promptness in making exhibits and

spoke of the popularity this feature of the meetings had attained.

Wm. Pitkin reported that previous committees on transportation had done their work so well that the present committee has found it wise to confine itself to an effort not to allow any changes to be made. The nurserymen are now, however, threatened with an attempt to change rule 1, releasing the carriers from all liability for loss of freight due to causes beyond the carriers' control, such as fires or wrecks, even when due to the carriers' negligence, unless 20 per cent. additional to the regular rate of freight is paid. Nurserymen were advised to take steps to prevent this consummation.

Peter Youngers of the Committee on Mutual Insurance had taken up the subject with the insurance commissioners of most of the states and found such conflicting and impossible requirements that the project appeared impractical and he advised dropping it, which was concurred in.

AFTERNOON SESSION.

To allow the members to have all of Friday for an excursion to Oconomowoc to accept the hospitality of the Citizens' Association of that place and of Mr. Fred Pabst, who invited the association to visit his magnificent home and farm, it was decided to hold an afternoon session, and the first business of the afternoon session was the report made by the vice-presidents. They recommended Seattle as the place of next meeting, and fully one-third of the members present voted for Seattle. After some oratorical pyrotechnics glorifying the land where cherries requiring two or three bites to a cherry are produced, the eloquence of Pitkin, the able champion of Rochester, N. Y., finally prevailed, and that city was chosen for next meeting.

The ticket nominated by the Vice-Presidents was headed by J. W. Hill, who, however, declined re-election, and it required a division of the house to decide as to whether the association would allow him to retire and lose the best presiding officer the society has had. This being decided, the following were elected: President, Charles J. Brown; vice-president, C. M. Hobbs; secretary, George C. Seager; treasurer, C. L. Yates. Chairman executive committee, J. H. Dayton; executive committee, E. M. Sherman, W. B. Chase, J. W. Hill, George C. Seager.

J. M. Pitkin next reported on the question of sending out cheap lists at end of the season. He started by excusing himself for not preparing beforehand and so had attempted to abstract from his colleague Josselyn all the information he could. To gain possession of him he proposed buying him a drink and questioning him. Josselyn was not averse to giving information but refused the drink. When pressed for his reason he said that since he had undergone an operation he was unable to indulge. Pitkin sympathetically wanted to know all about the operation and was ruefully informed that his informant had had a severe attack of rheumatism, and the doctor had cut out the booze. Other humorous anecdotes enlivened his talk but as to cheap lists his conclusions were that they were an injury to the trade and to the customers of

the nurserymen, and that more care should be used in deciding what stock to grow and thus have less stock left to carry over, and that stock to be utilized for a bonfire. He was followed by an exhaustive and valuable paper by Judge Eugene Stark on "A Few Points of Improvement." (This paper is so valuable that we will reserve its publication for future issue.)

A resolution was introduced by F. W. Kelsey thanking members of the Society of Economic Entomologists for co-operation with the aims of the Association and asking the state vice-presidents to use efforts to have the laws of their states amended to conform to laws in those states where they have proven least burdensome to nurserymen. In speaking on the motion, Mr. Kerr of Texas spoke at length on the subject of inspection laws and said that this is a burning question and would become more drastic as time went on. In illustration, he gave an instance of a nursery company in Texas being sued for trees in several orchards which had been attacked by crown gall, although other orchards from the same block of trees are sound. Trees were sold at four cents and the damages claimed in suits for imagined crops were now called worth from one to several dollars per tree.

THURSDAY FORENOON SESSION.

The meeting opened at 10 a. m. The first paper read was on the Pecan by H. D. Simpson of Vincennes, Ind. He described their culture and spoke of the enormous profits to be made. C. J. Malloy referred approvingly to the educational work being done by the National Council of Horticulture, and C. L. Watrous made a motion, which was adopted, providing that the committee having this work in hand should be composed of three members. J. S. Kerr of Texas followed with a paper dwelling in glowing language on the magnificent horticultural and other advantages of the great Southwest. A paper by Mr. Pickington on the elements of success in the nursery business came next. Too many varieties and too loose credits were his text. Prof. J. B. Phillips of Virginia sent in a paper on Peach Yellows, which was read by Prof. E. L. Worsham of Georgia.

Mr. Waters read a feeling obituary tribute to the late M. A. Albaugh. F. W. Kelsey presented resolutions empowering the transportation committee to confer with the Interstate Commission to prevent increase in freight rates and delays of shipments, and commending the reduction in foreign mail rates. Prof. L. R. Taft delivered an able lecture on spraying, and J. Horace McFarland talked eloquently on the nurseryman's duty in the civic improvement movement.

THURSDAY AFTERNOON SESSION.

This session was devoted to the Question Box and minor committee reports. When HORTICULTURE went to press the session was still going on and the members were looking forward with eager anticipation to the promised excursion to Oconomowoc, Wis., on the morrow. Detailed account of the remaining proceedings will appear in our issue of next week.

THE TEMPLE SHOW.



JOHN WATERER & SON'S EXHIBIT OF HARDY RHODODENDRONS.

In favorable weather and graced by the presence of Her Majesty the Queen on the opening day, the Temple Show was more choice and beautiful than ever. There is an atmosphere of rarity and richness not noted in more spacious exhibitions; limitation of space here, has tended to give a decided gain in quality, and this year there was no suffocating sense of overcrowding. The orchids were in glorious array. These aristocrats of the floral kingdom greeted and appealed to the elite society who thronged and richly enjoyed the rare feast of color and form displayed in the orchid groups. Sander's gold medal exhibit was full of choice things, notably of fine *Odontoglossum crispum*; two deep-spotted forms, *Mauritania* and *Lusitania*, will be familiar names on both sides of the Atlantic. *Dendrobium Bronckhardtii*, an imported species and lately in flower at Kew, is a glorified thrysi-florum with more graceful and lengthy racemes than that variety; flowers of a soft pale purple tinge.

The Veitchian cup, this year offered for orchids, was won by F. Monteith Ogilvie, Esq., of Oxford, with a grand group of plants which also received the gold Lindley medal for high cultivation. Charlesworth & Co. had a distinguished gold medal group which included their new hybrid *Odontioda Charlesworthiana*, *Cochlioda Noetzeliana* x *Odontoglossum Harryanum*. The flower is a vivid scarlet; the influence of *Harryanum* is not strongly

noted except in giving size to the flower.

Hugh Low & Co. well deserved a gold medal for a most beautiful effect with American carnations, so deservedly popular now in this country. Arranged in pillar form with a background of mirrors festooned with smilax, it was an object lesson in light and graceful grouping. Roses were finely shown. The new ramblers, *Paradise* and *White Dorothy*, were leading features in the groups of all the main growers. Paul's new hybrid tea, *Elaine*, received an award of merit.

Begonias in great quantity and quality show a marked advance yearly in compactness and size. *Blackmore* & *Langdon*, the pioneers of the fringed singles, had a fine stand of these increasingly popular bedding and greenhouse plants. The new American *Nephrolepis Amerpohlii*, was represented by a single plant and deserves to be better known here. New plants worth noting were Sander's foliage plants lately shown at Ghent; *Pereskia Godseffiana* makes a pretty basket plant. *Croton Fred Sander*, of a rich gold and green color, secured an award of merit.

Ivy dentata variegata, a rich clear creamy sport from the type, is an acquisition. The hardy plant groups arranged on the lawns, the pretty rock garden effects, the choice variety of herbaceous flowers, secured much attention and point to a great revival in outdoor stock in recent years, especially in perennial herbaceous plants.

EDGAR ELVIN.

LONGIFLORUM VERSUS MULTIFLORUM.

Can any one of our readers specify the difference between the longiflorum and the multiflorum lily, so called? The distinction exists, on paper, when bulb orders are given, but, according to some of our correspondents, is a very intangible quality in the bulbs as they grow. If anybody can explain where the dividing line is between the two forms he will confer a favor on many interested inquirers.

PRIMULA OBCONICA AS A BEDDING PLANT.

As a reader of HORTICULTURE I would like to inquire whether any one has ever tried or known *Primula obconica* being used as a bedding plant.

C. H. F.

You will find something worth reading on every page of HORTICULTURE.

NEWS OF THE CLUBS AND SOCIETIES.

NEW JERSEY FLORICULTURAL SOCIETY.

The last meeting prior to the summer recess was held on the fifth instant at the Society's rooms in Orange, when the floral display of the season's flowers from the border and greenhouse filled the tables.

Peonies from S. & A. Colgate, gardener William Read, Charles A. Munn, gardener John Hayes, Stewart Harts-horne, gardener Arthur T. Caparn, and Charles Hathaway, gardener Max Schneider, delphinium and digitalis from Thomas Jones of Short Hills and cattleyas, helio-cattleyas, cyripediums, lycastes from Lager & Hurvell and Orson A. Miller.

The topic for the evening, "Flowers for Commercial Uses," was introduced by John E. Lager, and George Smith, A. T. Caparn, John Hayes, Orson A. Miller and President Malcolm MacRorie took part in the discussion. Mr. Lager stated that the demand at the present time was for soft colors and delicate tints; that the popular taste showed a leaning for any form of loveliness; that prices were influenced by the desire for something out of the common run and that this sentiment had a tendency to attract trade to metropolitan centres where \$2.00 was frequently paid for an article commanding only 75 cents outside. Mr. Miller declared that in his experience as a salesman he had found that a woman never knows what she wants, and when the clerk had torn down a whole shelf of goods she would return to first article shown which she had previously declared she did not want. He reverted to the time-worn maxim that the ability of the salesman lay in disposing of what he was most anxious to get rid of, and that the prevailing taste was dominated by woman's vanity. Upon a call for named varieties of peonies by the chair most of those present stated that the most striking flowers present had been cultivated for a long time by themselves - so long as to have lost their identity.

George Smith was appointed to visit A. D. Rose who is lying seriously ill at his residence in Montclair.

JOSEPH B. DAVIS.

RETAIL FLORIST ASSOCIATION.

I wish to enlighten the wholesale as well as the general florist associates of the city of New York, also your valuable paper, that the so-called Retail Florist Association of the Borough of Brooklyn, city of New York, is an association formed for the purpose of bettering the trade, sociability and a standard time for closing, and not to do harm or cause any bitter feeling to any one.

Every retailer doing a legitimate retail florist business in the Borough of Brooklyn, city of New York, is cordially invited to become a member and assured of a square deal.

Our next regular meeting will be held at our rooms in the Imperial, on June 22nd at 9 p. m. sharp.

WM. A. PHILLIPS, Sec'y.

NEW YORK FLORISTS' CLUB.

The June meeting of this club, the last for the season, was held on Monday evening, June 8, with a rather light attendance. The various active committees which made reports were those on transportation, P. O'Mara, chairman, outing, W. E. Marshall, chairman, and ladies' night, W. Rickards, chairman. Mr. O'Mara's recommendation of the Lackawanna route to the Niagara Falls convention next August was adopted by a unanimous vote. Mr. Marshall distributed copies of the complete program for the annual outing and games to take place at Witzel's Point Grove, July 1. Mr. Rickards received a vote of thanks for his committee in recognition of the success of ladies' night last month. Mr. Marshall's report on the progress being made by the bowling team seemed to indicate that F. H. Traerdy will not be called upon to pay for many, if any,

FLORISTS' CLUB OF WASHINGTON.

The Florists' Club of Washington met on June 2nd, at Scottish Rite Hall. There was a very poor attendance and but little business transacted. This hall not being suitable for the meetings a committee was appointed to look up a better one. Wm. F. Gale was appointed chairman of the committee on "Sunday Law." It is desired to have a special meeting so that the opinion of each member of the club can be ascertained on this subject. It is understood that C. H. Mehan has shipped to F. H. Kramer of Washington, D. C., the pink seedling "No. 26," also "No. 27" and "No. 28." These roses will be grown for Mr. Mehan to be exhibited at the chrysanthemum show this fall.

AMERICAN APPLE GROWERS' CONGRESS.

The executive committee of the American Apple Growers' Congress held a meeting at the Southern Hotel, St. Louis, last week to make arrangements for their sixth annual convention which is to meet in that city in August next when topics of interest to apple men will be discussed. The speakers for this occasion have not yet been selected. Several reports were received on the apple crop, which were of a somewhat discouraging character.

Among the gentlemen present were Prof. H. C. Irish, Senator H. M. Dunlap, W. R. Wilkinson, T. C. Wilson and T. H. Todd. A large attendance at the convention has been promised.

ALBANY FLORISTS' CLUB.

The meeting on June 4 was with W. C. King and forty members, the largest number in some time, were present. Fred A. Danker, representing a committee who are preparing a circular upon the care of plants, for distribution among customers, asked for an extension of time. H. G. Eyres was unable to be present and deliver an address upon the cultivation of the amaryllis, with which he has been very successful, but W. C. King reviewed the spring trade in happy fashion and spoke optimistically of the future. Lewis Schaefer entertained with recitations, refreshments were served and the evening was altogether enjoyable.

CHICAGO FLORISTS' CLUB.

The Chicago Florists' Club held their regular meeting on the first Thursday of the month. W. O. Johnston of the Foley Manufacturing Co. was elected a member and W. A. Arnold, foreman for Geo. Reinberg, was proposed for membership. It was decided to hold the annual picnic on Sunday, July 13th, at Morton's Grove. This place was again selected because of its fine grounds and excellent shade. The program has not yet been decided upon.

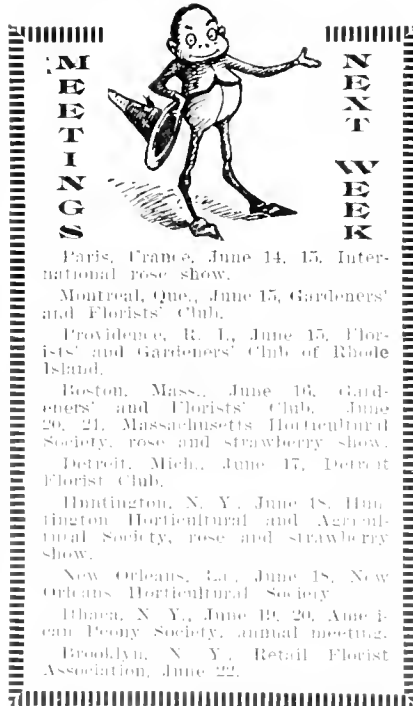

Paris, France, June 14, 15, International rose show.

Montreal, Que., June 15, Gardeners' and Florists' Club.

Providence, R. I., June 15, Florists' and Gardeners' Club of Rhode Island.

Boston, Mass., June 19, Gardeners' and Florists' Club; June 20, 21, Massachusetts Horticultural Society, rose and strawberry show.

Detroit, Mich., June 17, Detroit Florist Club.

Huntington, N. Y., June 18, Huntington Horticultural and Agricultural Society, rose and strawberry show.

New Orleans, La., June 18, New Orleans Horticultural Society.

Ithaca, N. Y., June 19, 20, American Peony Society, annual meeting.

Brooklyn, N. Y., Retail Florist Association, June 22.

Free tickets to the convention tournament on account of scores made in the practice games. Jos. Manda and John Donaldson had won the first and second prizes offered by Mr. Marshall. Special committees as appointed presented resolutions of condolence on the death of Secretary John Young's mother, William Scott and James Shanley, severally.

Harry Turner, gardener for Howard Gould at Port Washington, showed two vases of English carnations, Mrs. Trelawney and Calypso, for which a cultural certificate was awarded. Mr. Nash of the New York Botanical Garden then entertained the members with a series of beautiful stereoscopic pictures, in color, of hardy flowering and trailing shrubs and trees for which, in the case of a hearty vote of thanks was accorded.

The next meeting of the New York Florists' Club will be on the second Monday in September.

HORTICULTURAL SOCIETY OF NEW YORK.

The meeting of the Horticultural Society of New York and the American Rose Society, held in Bronx Park on June 10 and 11, was chiefly remarkable for the complete absence of the Rose Society members from the exhibition boards. There were but few exhibits of roses anyway, and they were all from the local society's membership. The most meritorious display, which filled the entire center of the hall, was made by J. H. Troy of New Rochelle; it was in every respect a remarkable display. Each variety was shown separately, and they were arranged in fancy baskets of all kinds. The whole display was an artistic triumph and illustrated quite novel ideas in showing roses. The Pierson cup for the most meritorious exhibit of the show went to this.

W. A. Manda staged a large group of *Wichuraiana* hybrids. F. R. Pierson had a group representative of the different races of roses.

Dr. W. Van Fleet had some entirely new *Wichuraiana* hybrids of exceptional merit. One (with the Cherokee) had semi-double, flatly expanded flowers four inches across, cream white; another (with *Souv. du Pres. Carnot*) was a glorious pale pink, double, three inches across. Both received the Horticultural Society's silver medal.

Variety was added by geraniums by R. Vincent & Sons Co.; sweet peas and a great display of peonies from F. R. Pierson Co.; orchids from Lager & Hurrell and Julius Roehrs Co.

Much attention was given to the vase of carnations of the *Malmaison* type from H. Turner, superintendent for Howard Gould, Port Washington.

At the formal meeting Leonard Barron gave an illustrated address in which the Rose family was reviewed in detail. The speaker praised the *Wichuraiana* and multiflora hybrids in particular and showed by a chart how rich was the material in the family as yet untouched by the horticulturist.

It was announced that a committee had been named for the fall show to take place in the American Museum of Natural History, Nov. 17, 18 and 19.

RHODODENDRON SHOW AT BOSTON.

The annual rhododendron show of the Massachusetts Horticultural Society was held at Horticultural Hall on Saturday and Sunday, June 6 and 7. As on previous occasions, while the display of rhododendrons was very liberal, a large proportion of the show was made up of other fine products of the garden and the effect of the rich exuberance of spring color was gorgeous in the extreme. The largest display of rhododendrons came from Walter Funnexell, gardener T. D. Hatfield, about 300 vases being filled. Mrs. J. L. Gardner, gardener Wm. Thatcher, was also a large contributor of rhododendrons. Irises from Mrs. F. Ayer, gardener Geo. Page, T. C.

Thurlow, W. W. Rawson & Co., Blue Hill Nurseries, F. J. Rea and others were in great profusion and made a glorious showing. Among the most notable attractions was a group of large fuchsias from Harvard Botanic Garden, gardener Robert Cameron. Rhododendrons and kalmias in pots and a very extensive collection of aquilegias, irises, campanulas, etc., were contributed by R. & J. Farquhar & Co. E. J. Shaylor was on hand with a group of choice peonies including some handsome seedlings. J. E. Rothwell, gardener E. Johansson, was represented by a table of orchid bloom among which were many rare gems. Mrs. Gardner also showed orchids. Among the vegetable exhibits that from the Spaulding estate, gardener F. E. Cole, attracted especial notice for the great variety of hot house vegetables which it comprised.

Following are the prize awards: Orchids.—25 plants, arranged for effect with foliage plants: 1st, Mrs. J. L. Gardner. Rhododendrons.—1st, Walter Hunnewell; 2d, Mrs. J. L. Gardner. German Irises.—1st, F. C. Thurlow & Co.; 2d, F. J. Rea. Hardy Herbaceous Flowers.—1st, Blue Hill Nurseries; 2d, ditto. Collection of Vegetables, grown in 1908. 1st, Spaulding Estate; 2d, W. J. Clemson. Silver Gilt Medal to R. & J. Farquhar & Co., for display of Rhododendrons and Kalmias. First Class Certificates of Merit to Harvard Botanic Gardens, for culture of *Cereus speciosus*, and Julius Heurlin for *Lupinus Moerheimii*. Honorable Mention to Harry S. Rand, for *Magnolia Watsoni*.

SOCIETY OF AMERICAN FLORISTS AND ORNAMENTAL HORTICULTURISTS.

Reduced Rates for the Niagara Convention.

The Trunk Line Association covering points in the states of New York, Pennsylvania, New Jersey, Delaware, Maryland and part of Virginia and West Virginia has granted a rate of one fare and three-fifths for the round trip on the certificate plan to those desiring to attend the convention. Other associations have not as yet granted any concessions.

Other particulars will be announced later. W. N. RUDD,
Secretary.

MISSOURI STATE BOARD OF HORTICULTURE.

The Missouri State Board of Horticulture held a three-days' session at Mountain Grove, Mo., the past week.

Twenty prominent horticulturists were present during the session. On Friday, the last day of the meeting, the following officers were elected: President, W. P. Stark; Vice President, R. L. Hill; 2nd Vice President, J. J. Chastin; Treasurer, T. H. Todd; Secretary, L. C. Howard.

The Tarrytown Horticultural Society have issued their prize schedule for the annual exhibition, November 4, 5, 6, and same can be had on application to E. W. Neubrand, secretary, Tarrytown, N. Y.

During Recess

Last Friday afternoon the Detroit contingent had a welcome excuse for a half-holiday because the local wholesale houses fought out a battle on the diamond at Belle Isle. The result was a score of 20 to 15 in favor of the Michigan Cut Flower Exchange. Andrew Ferguson, their pitcher, did splendid work. The Detroit Florist Supply House was their opponent. L. Charoat pitched for them.

The program for the eighth annual outing of the New York Florists' Club has been received and is in line with its predecessors as a most enticing list of prizes devoted largely to giving the young people a good time. There are 23 classes of three prizes each in the printed list, and it is understood that several others have been added since printing. No doubt the assemblage on board the steamer Isabel at starting time, 10 a. m., July 1, will be a large and happy one. We hope the weather clerk will take due notice and be agreeable.

The St. Louis Florist Club's annual outing has been arranged for by the club's trustees, Chas. Scoenle, W. C. Smith and Carl Beyer. Normandy Grove has been selected and the date is July 15th and the club members with their families and friends will enjoy the exclusive right to the grounds. This is a new location with more shelter and better dancing pavilion, bowling alleys and base ball grounds. The trustees are now engaged in making up the program for the day. A number of fine prizes have already been donated for all the events and the club's best outing in years is looked for.

CLUB AND SOCIETY NOTES.

J. Horace McFarland of Harrisburg, Pa., gave an illustrated lecture on June 8, on "Crusade Against Ugliness," under the auspices of the Publicity Club of Minneapolis, Minn.

The Gardeners' Club of Baltimore, organized in 1887, has appointed a committee to revise the by-laws and change the name to the Gardeners' and Florists' Club of Baltimore.

The Massachusetts Horticultural Society will hold their rose and strawberry show on June 20, 21, in Horticultural Hall, Boston; open Saturday from 12 to 6 p. m., Sunday, from 2 to 6 p. m.

The premium list of the American Peony Society's fifth annual exhibition, to be held at the State College of Agriculture, Ithaca, N. Y., has been issued. The dates of the exhibition are June 19 and 20. Copies may be had from the secretary, A. H. Fewkes, Newton Highlands, Mass., and entries should be addressed to the manager, L. D. Batchelor, Cornell University, Ithaca, N. Y. Prof. Whetzel will report as chairman of the committee on diseases of the peony. The business meeting will be held at 3 p. m., June 19.

Obituary

James Shanley.

In the death of this well-known florist of Brooklyn, N. Y., the florist trade loses a man who in all his dealings was an honor to the fraternity. He was beloved by his fellows for his straightforward integrity and kindly disposition. He was long a faithful member of the Society of American Florists and the New York Florists' Club.

Mr. Shanley was born in County Louth, Ireland, and came to this country as a young man, soon identifying himself with the florist trade in a humble way in New York City. He was employed by C. L. Allen at Queens and afterwards by John Condon in Brooklyn, working for the latter for fifteen or sixteen years, and then went into business for himself about seventeen years ago at the greenhouses



JAMES SHANLEY.

which he has conducted ever since, near the entrance to Greenwood Cemetery.

He had been a sufferer from rheumatism for some months, and this with other complications necessitated his going to St. Mary's Hospital two weeks ago, where three operations were performed which were not successful, and he died on Thursday, June 4, at the age of 62. He leaves a widow and one son, who will continue the business.

The portrait which appears herewith was taken 26 years ago, but it was the only one we could obtain. To Mr. Shanley's older friends it will, perhaps, appear familiar.

Mrs. Jerome Jones.

Mrs. Jerome Jones, wife of the head of the Jones, McDuffee & Stratton Company, died on June 3, at her home in Brookline, Mass. Mrs. Jones' name became familiar all over the world wherever chrysanthemums are known through the beautiful flower named for her by her father who originated it, the late H. A. Gane, of West Newton, Mass. Mrs. Jones was an ardent lover of flowers and a generous patron of the Massachusetts Horticultural Society.

Robert B. Graves.

Robert B. Graves, for the past thirty years identified with the florist business in Northampton, Mass., died at his home in that town on June 6,



ROBERT B. GRAVES.

at the age of eighty-eight. A few years ago he celebrated his golden wedding, and his wife now survives him, together with a daughter and two sons, one of whom, A. B. Graves, will continue the business.

George Roy.

George Roy, a well-known and suc-



GEORGE ROY.

cessful old-time gardener, died suddenly of apoplexy at his home in Bel-

videre, N. J., where he has been living in quiet retirement for the past twenty years. His age was 79. Mr. Roy was a native of Forchabers, Morayshire, Scotland, and served his gardener apprenticeship at Gordon Castle. He went to England, where he had charge of several large estates successively, and in 1858 came to America where he also held positions of large responsibility, the last being as superintendent of Etenbach, near Belvidere, N. J., where he remained for 19 years, after which he retired from active service. He leaves a widow, four sons and one daughter, the daughter and two sons being the offspring of a former marriage, one of whom is the well-known D. F. Roy, superintendent of Col. Converse's estate, "The Moorings," at Marion, Mass. One of the younger sons is John B. Roy, who has charge at the J. Sherman Hoyt place, Rowayton, Conn.

George H. Linsdale.

George Linsdale has been a familiar figure in the wholesale flower district of New York City for a quarter of a



GEORGE H. LINDALE.

century. In fact, it is nearly thirty years since, as a mere boy, he began peddling flowers from a basket, and by industrious application soon established a stand on 23rd street, afterwards opening a store at 23rd and Lexington avenue, which he conducted for many years. For the past three years he has been located on East 34th street, during the greater part of which time his health has failed continuously and his death, long expected, came on June 7.

Mr. Linsdale was 43 years of age and a native of Yorkshire, England. He leaves a widow and two daughters.

A Sad Fatality.

Miss Smith, the efficient superintendent of the horticultural department of the Griswold Seed Co., of Lincoln, Nebraska, was run over and killed by a reckless automobilist in that city. Miss Smith was a most estimable lady, very proficient in her department; an intelligent, Christian woman. Her loss is severely felt by the company, there are so few in the West with horticultural knowledge who can take her place.

C. S. HARRISON.

News Notes

Mrs. Russell Sage has donated a large plantation of rhododendrons to Central Park, New York.

J. L. Johnson, DeKalb, Ill., has bought the Irish greenhouses and will add them to his present range.

Among recent improvements on the estate of Joseph P. Bass at Bar Harbor, Me., is a large rose garden.

Charles P. Muller, florist, of Chester, Pa., has donated some 500 plants to the city for beautifying the public grounds.

Franks & Co., of Champagne, Ill., are making extensive additions to their greenhouse plant in the university town.

Wm. Hagemann & Co. are about to remove their offices from 55 Dey street, New York, to the new Hudson Terminal building.

Nurserymen report an increasing interest in small fruits among the farmers of Maine, who are this season buying largely of this stock.

A terrific hail storm visited Meadville, Pa., on May 29, lasting twenty minutes. Over 400 lights of glass were broken in the greenhouses of August Krueger.

The four wholesale houses in St. Louis will close, as last year, during the months of July and August at 5 P. M. each day and noon on Saturday.

Jas. G. Hancock, for twenty years of the firm of Geo. Hancock & Son of Grand Haven, Mich., now of La Grange, Ill., is rebuilding his residence lately destroyed by fire.

F. H. Kramer, Washington, D. C., has purchased the florist business of Walter Gorden, of 722 9th St., N. W., and after making extensive improvements he will conduct it as a branch store.

Hubert Hanson, for many years a grower of carnations at 4016 N. Clark St., Chicago, is about to retire from business and is offering his fine range of houses for sale. His plant is in what is known as Edgewater.

George Saltford is well settled into his new location at 42 West 28th street, New York, and his plans as confided to us indicate that he proposes to be strongly in evidence in the wholesale flower trade of the next season.

F. A. Greenlaw, who about a year ago leased the Piety Corner Greenhouses, Waltham, Mass., has been absent from home for more than a week, and anxiety is felt regarding him. J. T. Silman, on behalf of a creditor, is in charge of the place.

W. J. Elliott, the renowned plant auctioneer, will complete his labors for the season on Tuesday, June 23, with a sale of unprecedented magnitude and the celebration thereof at the headquarters, 42 Vesey street, New York, on that day will be something gorgeous.

Prof. Waugh of Massachusetts Agricultural College is giving the senior class in landscape gardening a week

ORCHIDS

We beg to announce the following fresh arrivals of Orchids all in finest condition.

CATTLEYA LABIATA. This is the third and last lot this season.
CATTLEYA TRIANE. The second lot to arrive in perfect condition.
CATTLEYA PERCIVALIANA in perfect shape.
CATTLEYA GASKELLIANA in best of condition, and
CATTLEYA MOSSIE.

Also Dendrobiums such as **D. THYRSIFLORUM, D. FORMOSUM, VANDA COERULEA, ONCIDIUM SPLENDIDUM,** etc., etc.

Write us for prices and we can assure you that you will be well pleased both as to quality of plants and price of same.

We also have a full line of supplies such as peat, live sphagnum and orchid baskets in all sizes.

LAGER & HURRELL, Summit, N. J.

of practical work in the Boston Park System. A schedule for each day is mapped out; they have brought their drawing and surveying instruments with them, and will have a taste of what work in the field actually means.

PROPAGATION OF SCIADOPITYS VERTICILLATA.

Editor HORTICULTURE:

I was much interested in looking over HORTICULTURE for May 23. The item which caught my attention, and that interested me most, was on the propagation of *Sciadopitys verticillata* by graft. I should like to know whether any one has propagated it after this manner in this country, and, if so, who? Shall be glad to hear from any reader of HORTICULTURE who has information on this point.

I think that it would be very interesting to know at just what time of the year this work should be done over here, and whether it is successful outside of the old country. P. T. B.

USEFUL BOOKS.

We can supply the following books, postpaid, at the prices listed:—

The Chrysanthemum. Herrington. Price, 50 cts.

How to Make Money Growing Violets. Saltford. Price, 25 cts.

Daffodils-Narcissus and How to Grow Them. A. M. Kirby. Price, \$1.10.

Commercial Violet Culture. Dr. B. T. Galloway. Price, \$1.50.

Water Gardening. Peter Bisset. Price, \$2.50.

Lawns and How to Make Them. Leonard Barron. Price, \$1.10.

Roses and How to Grow Them. By Many Experts. Price, \$1.10.

The New Cyclopedia of American Horticulture. L. H. Bailey. Four volumes; \$20.00.

How to Make School Gardens. H. D. Hemenway. Price, \$1.10.

NEP. WHITMANI

2 1/4 in., \$5.00 per 100

NEP. WHITMANI

3 1/2 in., \$25.00 per 100

BOSTON FERNS

2 1/4 in., \$3.00 per 100

H. H. BARROWS & SON Whitman, Mass.

ORCHIDS

Arrived in Grand Condition

CATTLEYA APETHYSTOOLOSSA true
CATT. BOWRINGIANA
LAELIA GRANDIS TENEBROSA
ONCIDIUM SARCODES

Write for Prices

To arrive shortly

Laelia purpurata, Laelia Boothiana (lobata), **Oncidium varicosum** Rogersii.

JOSEPH A. MANDA

191 Valley Road WEST ORANGE, N. J.

ORCHIDS

Largest Importers, Exporters, Growers and Hybridists in the World

Sander, St. Albans, England
 and 235 Broadway, Room 1
 NEW YORK CITY

IMPORTED ORCHIDS

Arrived in Superb Condition

Vanda coerulea, Cattleya Trianae, Cattleya gigas Sanderiana, Cattleya Schroederiae, Oncidium varicosum.

JULIUS ROEHRS CO., Rutherford, N. J.

ORCHIDS

Arrived in fine condition, **C. Mossiae, C. Percivaliana, C. Trianae, C. labiata, C. gigas Sanderiana, C. Harrisonia, C. Schroederiae, C. citrina Den, Formosum giganteum, D. Wardianum, D. Findleyianum, Oncidium Varicosum Rogersii, O. Tigrinum, O. Ornithorhynchum, Laelia anceps.** To arrive shortly, **Vanda Coerulea, Cattleya Gaspelliana, C. Mendellii, Phalaenopsis Amabilis, P. Schulleriana.**

CARRILLO & BALDWIN, Secaucus, N. J.

ORCHIDS

We advise the Growers and Private Places that our importations will now begin to arrive and we will have the following: **C. gigas, C. Trianae, C. Mendellii, C. Schroederiae, C. Trianae, C. Gaskelliana, C. Percivaliana, C. aurea, Miltonia vexillaria, C. Mossiae, C. speciosissima, C. labiata** and others. We guarantee that our plants will be extra fine with no disease or Cattleya fly and will quote the Lowest Prices in America.

ORDONEZ BROS., MADISON, N. J.

NEPHROLEPIS SCOTTII

in the following sizes, extra good value

25c., 50c., 75c., and \$1

Grand Specimen Plants at \$3, \$4, \$5, \$6.

JOHN SCOTT

Rutland Road and E. 45th St.

Tel. 2890 Bedford **BROOKLYN, N. Y.**



Do Not Miss It

IT WILL NOT BE REPEATED

An excellent opportunity afforded you. Take advantage of it.

TUESDAY, JUNE 23, NOON

We offer a fine collection of stock suitable to grow on, consisting of

Ferns, Ficus, Asparagus, Palms, Cocos, Crotons, Chrysanthemums and Assorted Table Ferns

W. ELLIOTT & SONS, Auctioneers, 42 Vesey Street, New York

A NOTABLE SOCIETY FETE.

The Charity Bazaar at Holm Lea, Professor C. S. Sargent's beautiful estate at Brookline, Mass., on Saturday, June 6, attracted an attendance of not less than 20,000 people representing the elite of Boston, New York and Newport society. It is asserted that in the social history of America probably nothing has ever been achieved which equaled this affair. Amidst all the dress and show, peerless beyond all else that nature and art could produce to adorn this great spring festival were the rhododendrons, always glorious at Holm Lea, better this season than for many years before.

NEWS NOTES.

The grounds of Mrs. Nathaniel Thayer, So. Lancaster, Mass., were opened to the public last week while the rhododendrons were in bloom.

June 7th was Confederate Decoration Day at Arlington and fully 5000 people gathered there to do honors to those who wore the grey. After impressive exercises hundreds of bunches of flowers were scattered on the graves.

A Rhododendron Carnival was held at Florence, Oregon, on May 20, in which a naval parade was the chief feature and the crowning of the Queen Rhododendra by Joaquin Miller, "the Poet of the Sierras," was the important event. The affair was so successful that it bids fair to be repeated another year on a larger scale.

VEGETABLE PLANTS

CABBAGE Wakefield, Early Flat Dutch, and other early varieties. Surehead, Late Flat Dutch, Danish Round and Ballhead and other late varieties at 20c per 100, \$1.00 per 1,000, \$8.50 per 10,000.

TOMATO Stone, Favorite, Paragon, etc., at 20c per 100, \$1.00 per 1,000, \$8.50 per 10,000. Dwarf Stone and Champion, June Pink and Early Jewell at 40c per 100, \$2.00 per 1,000.

CELERY White Plume, Giant Pascal, Gol. Heart and other varieties, 20c per 100, \$1.00 per 1,000, \$8.50 per 10,000.

BEEF Eclipse, Crosby and Egyptian, 25c per 100, \$1.25 per 1,000. Cash with order.

R. VINCENT JR. & SONS CO. WHITE MARSH, MD.

SPRING PLANT TRADE IN CHICAGO.

Chicago bedding out trade is growing to a close for the season of 1908 and the usual shortage of good bedding geraniums is developing. Though the prices in general were not as high as last season and the quantity grown considerably larger, the shortage is just as apparent. The greatest call is for S. A. Nutt with Beaute Poitevine for salmon pink and Jean Viaud for clear pink supplemented by a heavy call for Madame Sulleroi, coleuses and alyssum for borders and edgings. There has also been an unusually heavy demand for salvias and the new dwarf flowering variety Zurich is selling rapidly and bids fair to become very popular here in Chicago. As a rule, the growers of bedding plants have found a market for all their stock and as they could have sold more had they had it they will make arrangements to grow more extensively next year.

INCORPORATED.

The La Crosse Floral Co., La Crosse, Wis., C. E. Shaefer, W. R. Eilers; capital, \$10,000.

The Hickory Seed Co., Hickory, N. C., R. O. Abernathy, W. J. Shuford, A. L. Shuford, A. R. Sticker; capital \$20,000.

The Wilson Plant Oil and Fertilizer Company has been incorporated at Summit, N. J., for the purpose of manufacturing and selling fertilizers and other florists' supplies. Andrew Wilson is president and W. G. Badgley, secretary and treasurer.

The Brant-Hentz Flower Company has been incorporated under the laws of New Jersey to deal in cut flowers, plants and nursery trees and do decorating and landscape gardening. The company will pay special attention to the wholesale flower trade. Henry Hentz, Jr., will be president of the new company and Elwood Brant, treasurer. The principal office and greenhouses will be at Madison, New Jersey. Mr. Hentz is well known for his success as a grower of roses. Mr. Brant is also a successful florist and is the present owner of the property and greenhouses on Shunpike road to be acquired and extensively improved by the company.

ROSES

100 of the best Hardy sorts.

HYBRID PERPETUALS

Finest English Grown Plants

Dozen, \$3.50; 100 \$25.00

EVERBLOOMING HYBRID TEAS

Bloom from Midsummer until frost.

Dozen \$5.00; 100, \$35.00

Hardy Climbing Roses

All the leading sorts.

Catalogue Free on Application.

R. & J. FARQUHAR & CO.

6 and 7 So. Market Street,
Boston, Mass.

ROSES

Strong, Clean Stock. Grafted, Killarney, Richmond, Brides and Maids \$12.00 per 100, \$110.00 per 1000. Own Roots, Brides, Maids, Gates, Ivory, Perle, Killarney and Richmond. \$6.00 per 100, \$55 per 1000. All from 3½ in. pots. **P. R. QUINLAN, Syracuse, N. Y.**

CHRYSANTHEMUMS

In all standard varieties and colors now ready for planting from 2½ pots, \$3.00 per 100, \$20.00 per 1000.

CHARLES H. TOTTY, Madison, N. J.

DAHLIAS.

Now is the time to place your order for bulbs which will assure you getting named varieties in any quantity; prompt delivery.

DAVID HERBERT & SON,

Successors to L. K. Peacock, Inc.
ATCO, N. J.

Seed Trade

Hard times have not hurt the seed trade in Chicago. The leading houses report an excellent season and even the unfavorable weather has not materially interfered with their sales.

Mr. Gary, who has been putting out some of the acreage of beans for the Leonard Seed Co. of Chicago, has returned to the city and will soon be looking after some of the trade on the road again.

R. & J. Farquhar & Co., of Boston, report that the spring trade is holding longer and steadier than in any previous season in their experience. All classes of goods have had an unprecedented demand, but for a spraying material, spray pumps, etc., the call has been and still continues most remarkable.

Onion set crops in the middle west are backward on account of the wet weather of the past thirty days. Some of the large seed houses are awaiting developments of the next two or three weeks before taking on many more contracts than they have already made, as the prospects are now as favorable as could be wished for a large crop. Any further unfavorable weather conditions might lead to a heavy shortage in onion set crop in this section.

MISSOURI BOTANICAL GARDENS.

The first Sunday opening this year, of Shaw's Garden, St. Louis, took place Sunday, May 7th and the gate keeper counted 16,559 persons who entered the gates. The crowd was not as large as usual owing to the threatening weather and intense heat. Superintendent Irish with a large force was on hand to receive and show the visitors through the garden which surely looked beautiful. All the points of interest were visited but the orchid and cacti houses received special attention. The next Sunday opening will be the first Sunday in September.

SOW NOW

Double English Daisy

	Tr. Pkt.	Oz.
Giant, White	40c	\$3.00
" Mixed	40c	2.50
Longfellow, Pink	30c	2.50
Snowball, White	30c	2.50
" Mixed	30c	2.00

MICHELL 1018 MARKET ST. PHILA., PA.

PRIMROSE SEED

IMPROVED CHINESE

Finest grown large flowering, fringed, single and double, 15 varieties, mixed, 500 seeds, \$1.00; half pkt., 50c. Have the varieties separate, also.

JOHN F. RUPP, Shiremanstown, Pa
THE HOME OF PRIMROSES.

SWEET PEAS

For THANKSGIVING and CHRISTMAS

	Oz.	¼ lb.	½ lb.	Lb.
BODDINGTON'S CHRISTMAS WHITE.....	10c	40c	60c	\$1.00
" " PINK.....	10c	40c	60c	1.00
" SNOWBIRD, the earliest forcing white ...	15c	75c	1.25	2.00

ALL THE ABOVE MAILED FREE

ARTHUR T. BODDINGTON, Seedsman
349 West 14th Street, - NEW YORK CITY

ASTER GROWERS ATTENTION:—

Our Seed is All Sold. If you failed to get some it is your loss. However:— Get a Competition Card Now, Enter your name as an Aster Grower of America and win part of our \$250.00 offered in prizes. Entry free. All information gladly given. No cost to you except to prepay the express charges on flowers sent in competition.

Altimo Culture Co., Canfield, Ohio.

Thorburn's Seeds

Seeds of ASPARAGUS PLUMOSUS NANUS, \$2.00 per 1000.

Seeds of ASPARAGUS PLUMOSUS ROBUSTUS, \$2.00 per 1000.

COLD STORAGE LILY OF THE VALLEY PIPS

JAPAN LILIES, JAPAN IRIS

For prices, state quantities required.

J. M. THORBURN & CO.

33 Barclay St., through to 38 Park Place
NEW YORK

Best Quality Fall Bulbs

It is to your advantage to place your order early. Send us a list of your wants and we will quote you rock-bottom prices. Copy of our Florists' Bulb Catalogue will be sent upon request. Catalogues now ready.

VICK'S SUPERB PANSY SEED

All the best varieties in separate colors

VICK'S SUPERB MIXTURE

the best strains from all the leading named sorts

1-8 oz. 75c. 1-4 oz. \$1.50 Ounce \$5.00

JAMES VICK'S SONS, Rochester, N. Y.

PRIMULA, FRINGED SINENSIS

This seed has been grown for us by a specialist in the culture of Primula, and he has produced plants of sturdy growth, large, thick flowers beautifully fringed and carried on erect stems well above the foliage; unequalled in size, substance and beautiful colors.

Giant Pe section strain, Finest Mixed, 1-64 oz., \$1.00
Pure White, Brilliant Pink, Blue, Chiswick Red, and
Crimson, 1-64 oz., \$1.00.

H. E. FISKE SEED CO.
13 Faneuil Hall Sq., BOSTON, MASS.

CAULIFLOWERS SEED

CABBAGE SEED

HJALMAR HARTMANN & CO.,
12 Stormgade,
COPENHAGEN, DENMARK.

SOW NOW MY STRAIN OF

Hardy Garden Carnations as: Per Tr. Pkt.

Special Mixture of extra double flowers.....	\$2.50	.30
Dwarf Scarlet Grenadin.....	2.00	.30
Early Dwarf Vienna, finest mixed.....	1.00	.20
New Early White Vienna, fine for cut.....	1.50	.20
New Early Dwarf Hardy Garden Pinks, in splendid colors, mixed.....	4.00	.50

O. V. ZANGEN Seedsman Hoboken N. J.

JUST ARRIVED

LARGE SHIPMENT OF

High-Grade SCOTCH SOOT.

We have the Stott Double Nozzle
THOMAS J. GREY CO.

32 & 33 So. Market St., BOSTON

BRIDGEMAN'S SEED WAREHOUSE

RICKARDS BROS.

Props.

37 East 19th St., - NEW YORK CITY

BRASLAN SEED GROWERS CO.

GROWERS FOR THE

WHOLESALE TRADE ONLY

SAN JOSE, - - CALIFORNIA

BRECK'S SEEDS

For Farmer, Market Gardener and Florist
New Crop High Grade

Catalogues mailed free on application

Joseph Breck & Sons Corp.
47-54 NO. MARKET ST., BOSTON, MASS.

Winter-flowering

SWEET PEA SEED

All Colors

New crop ready in August next. Ask for list.

A. C. ZVOLANEK
ORIGINATOR BOUND BROOK, N. J.

Burpee's Seeds

PHILADELPHIA

Blue List of Wholesale Prices mailed only to those who plant for profit.

JOHN BREITMEYER'S SONS

Cor. Miami and Gratiot Aves.
DETROIT, MICH.

Artistic Designs . . .
High Grade Cut Blooms

We cover all Michigan points and good sections of Ohio, Indiana and Canada

William J. Smyth FLORIST

Cor. Michigan Ave. and 31st St., CHICAGO

We ship to all points in Illinois and Iowa.

Phones: Douglas 744, Douglas 523, Douglas 740

M. C. and J. E. HAUSWIRTH

232 Michigan Ave.
CHICAGO

AUDITORIUM ANNEX Tel. Harrison 585

SAMUEL MURRAY Florist

Coates House Conservatory
1017 BROADWAY, KANSAS CITY, MO
Both 'Phones 2670 Main

FRED C. WEBER FLORIST

4326-28 OLIVE STREET ST. LOUIS, MO.
Established 1873
Long Distance Phone Bell Lindell 676



WASHINGTON,
D. C.

GUDE'S

The Far-Famed Flowers of TORONTO

Delivered on mail or telegraph order for any occasion, in any part of the Dominion.

JOHN H. DUNLOP,
96 Yonge St., - Toronto, Ont.

The Park Floral Co.

J. A. VALENTINE
Pres.

DENVER, COLORADO

WILLIAM L. ROCK FLOWER CO.

KANSAS CITY, - MO.

will carefully execute orders for Kansas City and any town in Missouri or Kansas.

BUSINESS CHANGES.

A Lange will move to 12 Madison St., Chicago, next door to his present location, on July 1.

Mr. Shepherd of Boston succeeds George Reed at the Blantyre greenhouses, Lenox, Mass.

B. L. Dresser has bought the hot-houses at Pine Grove cemetery, Whitesville, and will move them to his farm in Exbridge, Mass., where he will start in the nursery business.

NEW RETAIL FLOWER STORES.

Shank Floral Co., Newton, Kan.

Chicago, Ill.—B. S. Norkowski, 4846 S. Ashland avenue.

STEAMER DEPARTURES

Allan.

Victorian, Montreal-Liv'pl...June 19
Corsican, Montreal-Liv'pl...June 26

Anchor.

California, N. Y.-Glasgow...June 20
Caledonia, N. Y.-Glasgow...June 27

American.

St. Louis, N. Y.-S'hampton...June 20
Phila., N. Y.-S'hampton...June 27

Atlantic Transport.

Minneapolis, N. Y.-London...June 20
Minnehaha, N. Y.-London...June 27

Canadian Pacific.

Emp's of India, Mont'Liv'pl...June 20
Cunard.

Ivornia, Boston-Liverpool...June 16
Lusitania, N. Y.-Liv'pl...June 17
Shavonia, N. Y.-Medit'n...June 18
Mauretania, N. Y.-Liv'pl...June 24

French Line.

La Savoie, N. Y.-Havre...June 18
La Province, N. Y.-Havre...June 25

Hamburg-American.

Kaiserin Aug Victoria
N. Y.-Hamburg...June 18

Holland-American.

Potsdam, N. Y.-Rotterdam...June 17
Noordam, N. Y.-Rotterdam...June 24

North German Lloyd.

Kronpr'z Wil., N. Y.-Bremen...June 16
Fred'k der Grosse,
N. Y.-Bremen...June 20

Kaiser Wm. II.,
N. Y.-Bremen...June 23

Red Star.

Zeeland, N. Y.-Antwerp...June 20
Kronland, N. Y.-Antwerp...June 27

White Star.

Adriatic, N. Y.-S'hampton...June 17
Baltic, N. Y.-Liverpool...June 17
Cedric, N. Y.-Liverpool...June 18
Cretic, N. Y.-Medit'n...June 20
Majestic, N. Y.-S'hampton...June 24
Arabic, N. Y.-Liverpool...June 25
Cyrus, Boston-Liverpool...June 29

NEWS NOTES.

L. Bauman & Co., 76 Wabash Ave., Chicago, will be found in their new quarters, 118 E. Chicago Ave., about July 1st.

The florists' supply business is holding up well in the West. Some of the Chicago houses report an unusually good year.

The florists of Belleville, Ill., enjoyed a great business last week. The Egyptian Drummers held its annual meeting there and the floral parade was one of the features a number of very attractive floats being made up by the florists.

Chicago.

Established in 1857



1657-1659 Buckingham Place

L. D. Phone 558 Lake View. Send us your retail orders.

We have the best facilities in the city.

ALEX. McCONNELL

571 FIFTH AVENUE
NEW YORK CITY

Telegraphic orders forwarded to any part of the United States, Canada, and all principal cities of Europe. Orders transferred or intrusted by the trade to our selection for delivery on steamships or elsewhere receive special attention.

Telephone Calls, 487 and 488 38th St.
Cable Address, ALEXCONNELL

DAVID CLARKE'S SONS

Deliver orders from any part of the country to
New York City

Or OUT-GOING STEAMERS

Write or telegraph

2139-2141 Broadway, New York
Telephone 1552-1553 Columbus

YOUNG & NUGENT

42 West 28 St., NEW YORK
"FLOWERS BY TELEGRAPH"

Flower Deliveries

In Brooklyn and other Long Island Points
New York City, New Jersey, etc. At Theatres,
Hotels, Steamers or Residences.

WILSON

Fulton St. and Greene Ave., Brooklyn, N.Y.

ALBANY, N. Y.

EYRES

Flowers or Design Work

DELIVERED IN ALBANY AND VICINITY
ON TELEGRAPHIC ORDER.

11 NORTH PEARL ST., ALBANY, N. Y.

YALE

Orders for flower deliveries to Yale College and all other Connecticut points carefully filled and delivered by

J. N. CHAMPION & COMPANY
1026 CHAPEL STREET NEW HAVEN, CONN.

JACOB SCHULZ, 644 Fourth Ave., LOUISVILLE, KY.
Cut Flowers of BEST QUALITY in season delivered promptly to any address.
Write, Telegraph or Telephone.

Cumberland and Home Phones 223 and 984

ATLANTA FLORAL CO.

41 Peachtree Street, ATLANTA, GEORGIA.

In ordering goods please add "I saw it in HORTICULTURE."

Personal.

Visitors in Chicago: A. L. Glasser, of Dubuque, Ia.; Mr. Kaber, of La Porte, Ind.

S. Carlquist of Lenox, Mass., sailed from New York for a European visit on June 10.

Mrs. S. Hefele, New York, is at the St. Francis Hospital slowly recovering from a severe illness.

Alexander McConnell, of New York City, is recuperating at Norfolk, Conn., after his recent illness.

George H. Bartlett, formerly of Suncook, is now manager of an extensive plant in Franklin, N. H.

Philip Einsman of Astoria, N. Y., is about to start for his home in Darmstadt, where his father is very sick.

Mayor Hibbard has reappointed Superintendent Sullivan of the public grounds department of Boston for the coming year.

Harry Balslev, representative of the Detroit Pot Manufactory, has been calling on his Chicago patrons this week.

B. S. Slinn, Jr., wholesale florist, New York, sailed on June 3 for a summer tour in France and other parts of Europe.

Arthur Rogers, assistant salesman for E. A. Asmus at the New York Cut Flower Company, is reported as dangerously ill.

J. R. Shields, gardener for F. G. Crane, of Dalton, Mass., will sail on the S.S. Manretania June 24 for a two months' trip abroad.

William H. Kuebler, Brooklyn's commission florist, sailed with Mrs. Kuebler and two children, on June 3, on a visit to Norway.

A. I. Simmons, florist, on 63rd street, Chicago, who has been very ill, is now convalescing and is contemplating taking a trip soon.

J. H. Colman, at one time a well-known salesman for the Cleveland Seed Co., has taken a position with the Leonard Seed Co. of Chicago.

Paul Beyers of A. F. Beyers of South Bend, Ind., was a Chicago visitor this week.

We manufacture

Self Watering Flower Boxes
for
Windows, Porches and Cemeteries
splendid for placing on



GRAVES

Water reservoir needs refilling but once in two weeks. Made of galvanized iron. Rust proof, leak proof, beautifully finished, and will last for many years. Made in all sizes.

Send \$2.00 for Sample Box
37 in. long and see how quickly you can double your money and also increase the sale of your plants. Illustrated booklet sent free on request

Illinois Heater & Manufacturing Co.
3946 Wentworth Ave., Chicago, Ill.

HART'S HANDY HANDLE

"At Easter-time, with a little chiffon decoration, and the Handle, we were able to increase the value of plants from 50% to 100%."— H. E. WILSON.

Write for descriptive circular and prices

GEO. B. HART, 24 Stone St., Rochester, N. Y.

Mr. Beyers reports trade as good, and was looking up stock.

C. Willard Smith, who handles a large share of the jobbing and canning trade for the Leonard Seed Co. of Chicago, is able to again resume his duties after a short illness.

Among the passengers sailing on the Ryndam, Wednesday, June 10, were John Kemper, Brooklyn N. Y., Mr. Ebdinge, of Ebdinge & Van Goos, Mr. Kester, of Koster & Co., Buskoop, Holland.

Mr. and Mrs. George M. Stumpp, of New York, sailed June 9 on the Kronprinzessin Cecile. They will take an automobile trip in Europe and expect to meet M. O. Jordan, of the J. M. Keller Co. and Mrs. Jordan in Cologne. Mr. and Mrs. Jordan sailed last week on the New Amsterdam.

J. H. Wilson has resigned his position with Vaughan's Seed Store, Chicago, and has gone on the road for the Leonard Seed Company. Mr. Wilson came from Boston a little over a year ago. He has made a great many friends in Chicago and proved himself a very capable and energetic business man.

Mr. and Mrs. Fred C. Weber and their daughter, Adele, in company of Miss Tillie and Linnie Meinhardt, all of St. Louis, will leave, the latter part of this month, for a trip to Denver, Colorado Springs, Yellowstone Park and other points of interest in the far west. This pleasure trip will consume a month.

Weigel & Ujfalussy, who succeed to the business of Emil Steffens as manufacturers of florists' wire designs and sundries, have taken a well-advised course in establishing their ware rooms at 136-138 West 28th street, close to the centre of the wholesale florist trade of New York. The Steffens' business has been in existence for over forty years and under aggressive management offers an excellent opportunity for development.

PROMPT DELIVERY IN BOSTON
AND ALL NEW ENGLAND POINTS
HOUGHTON & CLARK
396 Boylston St., Boston, Mass.



BOSTON'S BEST
In Quality and Design
Can be relied upon when you transfer your retail orders to
EDWARD MACMULKIN
194 Boylston Street, Boston

Send flower orders for delivery in
BOSTON
and all
NEW ENGLAND POINTS
THOS. F. CALVIN
124 Tremont St., Boston

TRANSFER
Your orders for flower or plant delivery in Eastern New England to
JULIUS A. ZINN,
2 Beacon St., Boston.
Fine Design Work a Specialty.

Baskets Made to Order FOR FLORISTS
I have the most skilled Tribe of Pottowattomie Indian basket makers in the world ready to make any thing in the shape of florists' baskets at low prices. **Be Original**—have your baskets made to order in your own styles.
E. H. HITCHCOCK, GLENWOOD, MICH.

Wired Toothpicks

Manufactured by

W. J. COWEE, BERLIN, N. Y.

10,000....\$1.75; 50,000....\$7.50. Sample free.
For sale by dealers

WEIGEL & UJFALUSSY

Successors to Emil Steffens

Manufacturers of Florists' Wire Designs and Supplies. Established 1866.

136-138 W. 28th St., New York City
Telephone 1922 Madison Sq.

Anything in the line of wire work and designs not listed in our catalog will be made up promptly on short notice.

ROSE PLANTS

Ready for Delivery.

2000 Brides, 3 1/2 in. pots	\$6.00	\$50.00
2000 Maids " "	6.00	50.00
2500 Brides, 2 in. "	3.00	25.00
2000 Richmond, 2 1/2 in. pots	5.00	45.00
2000 Killarney, 3 in. pots	8.00	

We guarantee plants to give satisfaction.

The Leo Niessen Company
1209 Arch St., Philadelphia, Pa.
Open from 7 a. m. to 8 p. m.

FOR THE JUNE GIRL

CATTLEYS

Extra Stock, \$6.00 per doz.

VALLEY

The Come-again kind, No. 1 \$3, Fancy \$4 per 100.

S. S. PENNOCK-MEEHAN CO.
1608-1620 Ludlow St. PHILADELPHIA
"The" Wholesale Florists of Philadelphia

EVERYTHING SEASONABLE IN
CUT FLOWERS
EDWARD REID, Wholesale Florist
1526 Ranstead St., PHILADELPHIA
STORE CLOSES 8 P. M.

CHAS. W. MCKELLAR
51 WABASH AVE., CHICAGO
Western Headquarters for Choice Orchids
Valley, Roses and all Cut Flowers

PETER REINBERG
WHOLESALE
CUT FLOWERS
51 Wabash Av., Chicago, Ill.

CUT FLOWER BOXES
EDWARDS FOLDING BOX CO
MANUFACTURERS
PHILADELPHIA, PA.

AMERICAN BEAUTY and all other ROSES
LILY OF THE VALLEY, CARNATIONS
WELCH BROS., 226 Devonshire St., Boston, Mass.

New Crop Dagger Ferns
\$2.00 per 1000
Case lots of 10 fl. at \$1.50 per 1000
W. E. MCKISSICK WHOLESALE FLORIST
PHILADELPHIA
1619-1621 RANSTEAD ST.

DAILY CONSIGNMENTS
From 40 to 60 Growers
We can care for your cutflower wants to advantage.
E. F. WINTERSON CO.
46-47-49 WABASH AVE., CHICAGO

Rice Brothers
115 N. 6th Street, MINNEAPOLIS, MINN.
WHOLESALE FLORISTS and SUPPLIES
CUT FLOWERS received twice daily, and can fill your orders to your satisfaction. A complete line of Hardy Greens - WILD SMILAX, BOXWOOD, HARDY FANCY FERNS, GALAX LEAVES.
Write for quotations on large quantities.

E. A. BEAVEN
Southern Wild Smilax,
Log Mosses,
Natural and Perpetuated - at Wholesale
EVERGREEN, ALABAMA.

TOWER HOTEL
Niagara Falls, N. Y.
is soliciting your patronage during the S. A. F. Convention.
Very truly yours,
M. J. HOENIG, Prop.

WHOLESALE FLOWER MARKETS—TRADE PRICES—Per 100 TO DEALERS ONLY

	CHICAGO June 9	TWIN CITIES June 8	PHILA. June 8	BOSTON June 11
ROSES				
Am. Beauty, Fancy and Special...	25.00 to 35.00	25.00 to 30.00	15.00 to 25.00	15.00 to 20.00
" Exata	20.00 to 25.00	15.00 to 22.00	12.00 to 15.00	12.00 to 15.00
" No. 1	18.00 to 20.00	10.00 to 12.00	5.00 to 10.00	6.00 to 10.00
" Lower grades	6.00 to 10.00	6.00 to 8.00	1.00 to 4.00	1.00 to 4.00
Bride, "Maid, Fancy & Special	4.00 to 6.00	6.00 to 8.00	6.00 to 8.00	4.00 to 6.00
" Lower grades	2.00 to 4.00	2.00 to 5.00	2.00 to 3.00	.50 to 1.00
Killarney, Richmond, Fan, & Sp.	8.00 to 10.00	8.00 to 10.00	6.00 to 8.00	4.00 to 6.00
" Lower grades	4.00 to 6.00	5.00 to 7.00	1.00 to 4.00	.50 to 4.00
Chatenay, Fancy and Special	6.00 to 8.00	5.00 to 8.00	5.00 to 6.00	4.00 to 6.00
" Lower grades	4.00 to 6.00	3.00 to 5.00	1.00 to 4.00	.50 to 3.00
Kaiserin, Carnot	6.00 to 8.00	6.00 to 8.00	3.00 to 8.00	.50 to 6.00
Golden Gate, Ivory	4.00 to 6.00	6.00 to 8.00	3.00 to 8.00	.50 to 4.00
CARNATIONS				
Fancy and Novelties	1.00 to 2.00	2.50 to 3.50	3.00 to 4.00	1.00 to 2.00
Ordinary75 to 1.00	1.75 to 2.00	.50 to 1.50	.30 to 1.00
MISCELLANEOUS				
Cattleyas to	40.00 to 50.00	40.00 to 50.00	40.00 to 50.00
Lilies	5.00 to 6.00	6.00 to 8.00	10.00 to 15.00	3.00 to 5.00
Lily of the Valley	3.00 to 4.00	2.00 to 3.50	2.00 to 4.00	1.00 to 3.00
Daisies20 to 1.00	.75 to 1.25	.50 to 1.00	.50 to 1.00
Pansies25 to .50	1.50 to 2.50	.30 to .50	.25 to .50
Peonies	3.00 to 5.00	6.00 to 10.00	2.00 to 8.00	2.00 to 4.00
Cladioli	10.00 to 12.00	3.00 to 5.00	3.00 to 5.00	2.00 to 3.00
Mignonette75 to 1.50	2.00 to 3.00	1.00 to 2.00	1.00 to 2.00
Gardenias	25.00 to 35.00	5.00 to 15.00	12.50 to 15.00	12.00 to 25.00
Sweet Peas50 to 1.00	.60 to .75	.50 to 1.00	.15 to .50
Adiantum	1.00 to 1.25	.75 to 1.00	1.00 to	1.00 to 1.50
Smilax	10.00 to 12.00	12.00 to 15.00	15.00 to 25.00	10.00 to 12.00
Asparagus Plumosus, strings	30.00 to 40.00	35.00 to 50.00 to 50.00	25.00 to 50.00
" " & Spreu. (100 bchs.)	15.00 to 20.00	35.00 to 50.00 to 50.00	15.00 to 50.00

J. A. BUDLONG

37-39 Randolph Street, CHICAGO.

Roses and Carnations WHOLESALE
A Specialty..... GROWER of

CUT FLOWERS

ROBERT J. DYSART,
Public Accountant and Auditor
Simple methods of correct accounting especially adapted for florists' use.
Books Balanced and Adjusted
Merchants Bank Building
28 STATE ST., BOSTON
Telephone, Main 54.

J. B. Murdoch & Co.
Wholesale Florists
FLORISTS' SUPPLIES
714 Penn Ave., PITTSBURG, PA.
Long Distance Phone 1435 Court.

H. BAYERSDORFER & CO.

Known to the Trade for the past 30 years as the

Representative Florists' Supply House of America

Always first in the market with anything that is new, novel and appropriate.

FOR THE MONTH OF WEDDINGS AND GRADUATIONS

We have prepared for your needs with a stock of desirable and useful goods, unequalled in quality and extent anywhere on this continent and at prices that cannot be beaten. Orders by mail or telegraph will be filled immediately. Catalogue on application.

H. BAYERSDORFER & CO., 1129 Arch St., Philadelphia

FLOWER MARKET REPORTS

BOSTON Market conditions here are unchanged from last week except in the increased receipts of peonies and the reduced values of roses and carnations. Peonies are in large supply and are selling fairly well. Lily of the valley and sweet peas also seem to move a little better, but business is very slow, taken as a whole. There are quantities of lilies around and they are very difficult to dispose of. The barometer of the flower business, otherwise known as the street fakir, is proclaiming loudly his offer of "fine large roses a dozen for 5 cents." That tells the story.

CHICAGO The cut flower market is still suffering somewhat from an over-supply of stock. Flowers are, however, of better quality than a week ago, and with commencements near at hand, the surplus will soon disappear. Weddings, too, as the month advances, are using up some of the best flowers, particularly roses. Peonies are coming in faster than they can be used to advantage and the retailer and the wholesaler are both having their troubles trying to satisfy the grower, who in turn cannot see where his profits are to come from. Pansies are looking fine, and the blooming plants put up in baskets are very attractive, selling more readily than the cut blooms. Roses are plentiful, and good stock is bringing fair prices. A few good lilies are seen, and gladioli are more in evidence each day. Sweet peas, especially in white and light pink, are plentiful in the market. Surely purchasers since the Memorial holiday have had everything to choose from and could buy at decidedly low prices, considering the quality of the stock.

DETROIT It is very difficult just now to quote prices on anything reliably. The two controlling factors, quality and demand, are both absent. This year's crop of large June weddings is very small and all the other work does not compare at all with the enormous quantity of flowers shipped in. In this connection it might be well to mention that express companies are not in need of our special assistance. If the growers would more closely scrutinize what they do send it would reduce ex-

press charges quite a little and save the commission men the trouble of culling out. The Michigan Cut Flower Exchange have received their first lot of fresh fancy ferns; this firm has so far 3000 peonies put into cold storage.

NEW YORK Steadily shrinking in activity day by day the flower market in the metropolis is rapidly assuming its mid-summer character. Already are seen large quantities of small roses cut from young stock. Thus far, as usual, Bride and Bridesmaid predominate, but Richmond and Killarney make up most of the balance. Peonies are at their height this week and almost monopolize the market and demand. Carnations are very abundant and so are lilies, the former showing the wear and tear of the season unmistakably. Cattleyas, mainly Gigas, as now coming in are simply superb. Among the promiscuous stock in evidence at present are gladioli, centaureas, pyrethrums, irises and moss roses. Sweet peas are of excellent quality.

PHILADELPHIA Conditions have improved slightly, not up to former Junes but as good as was expected. Many of the Beauty growers are now throwing out and replanting which has had an appreciable effect on prices. The quality still keeps good. Fancy quality in Brides and Bridesmaids was in good demand but the bulk of the stock was mediocre. Killarneys are showing the effect of the weather more than any other rose at present, and mildew is very prevalent. Kaisers are poorer than usual at this season. As for carnations one-half the stock coming in is so poor that even the fakirs will not look at it. There is excellent demand for the few fancies available. Orchids are scarcer, Cattleya Mossie mostly. Lily of the valley selling better; quality very good. Sweet peas also better and demand excellent. Peonies are coming in plenti-

fully and are now finding a ready market. Among the minor items conspicuous at present are Coreopsis grandiflora, Lupinus polyphyllus, Centaurea imperialis, snapdragons, and yellow daisies. Greens plentiful and good. Gardenias have shortened up considerably and this market is now in healthier condition.

WASHINGTON There is but little doing in the flower trade here except in the matter of weddings and commencements. The sweet pea market is demoralized, it being next to impossible to get rid of them at any price. There is some very fine phlox in the various stores and it seems to find better sale than the other cheap flowers. Roses hold their own remarkably well, especially Beauties, there being a good demand for them for most of the commencements.

PHILADELPHIA NOTES.

William Palek, with the Pennock Bros., sails June 25th for a well-earned vacation to his native land, Denmark.

Jno. Burton's two new truss houses of the King Construction pattern are now almost complete and only await the company's inspection for the final touches and the planting.

It is rumored that Joseph Heacock will cut out several of his Beauty houses the coming season and devote them to other crops.

We hear the highest praise on all sides for Arthur Niessen's philosophical paper in modern methods in flower raising and distribution. We must diagnose the trouble correctly before we can cure. Now what is the cure? Shoot the fellow who dares to build the next greenhouse? Or what?

Beloit, Wis., June 1 (Special).—Frank T. Mahan, a florist, was fined \$25 today for employing children under 14 years of age.—Milwaukee (Wis.) Sentinel.

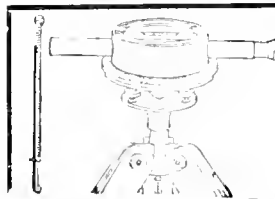

Bostrom Improved Builders' Levels and Farm Levels

For Park, Cemetery and Landscape Gardening use, take the place of expensive Engineering Instruments. Simple in construction, easily adjusted, more substantial and less cumbersome than the more elaborate and complicated instruments. Practical, up-to-date instrument that any one can use. Write for descriptive circulars and be convinced that this Level is necessary to complete your outfit. Builders' Level \$25.00. Farm Level \$12.50.

BOSTROM-BRADY MFG. CO., 139 Madison Avenue, ATLANTA, GA

FORD BROTHERS
 48 West 28th Street, NEW YORK
FINE ROSES FANCY CARNATIONS
 A Full Line of All CUT FLOWERS
 Telephone, 3870 or 3871 Madison Square

H. E. FROMENT,
 Wholesale Commission Florist,
 Choice Cut Flowers,
 57 West 28th St., :: NEW YORK.
 Telephones: 2200, 2201, Madison Square.

The Reliable Commission House
 Richmond Roses and Rich Flowers
 of all varieties
JOS. S. FENRICH
 110 W. 28th Street, New York
 Tel. 324-325 Madison Square

Alfred H. Langjahr
 All choice cut-flowers in season. Send
 for quotations. Correspondence with
 shippers of first-class stock invited.
55 West 28th Street, New York.
 Telephones 4626-4627 Madison Square

Edward C. Horan
Wholesale Florist
 55 WEST 28th ST.
 Tel. 1462 Madison Square New York
 1463

JOHN I. RAYNOR
Wholesale Commission Florist SELLING AGENT FOR
 LARGEST GROWERS
 A full line of Choice Cut Flower stock for all purposes. Comprises every variety
 grown for New York market, at current prices
 TEL. 1998 MADISON SQUARE 49 W. 28 St., New York City

Walter F. Sheridan
 Wholesale Commission Dealer in
CHOICE CUT FLOWERS
 39 West 28th Street, New York
 Telephone: 3532-3533 Madison Square

HEADQUARTERS FOR NOVELTIES
ORCHIDS A SPECIALTY
 THE HIGHEST GRADE OF VALLEY ALWAYS ON HAND
 GARDENIAS, DAISIES, ROSES AND CARNATIONS
 Telephone
JAMES McMANUS, 759 Mad. Sq. 42 W. 28th St., New York

PHILIP F. KESSLER 55 & 57 W. 26th St., New York City
 Commission Dealer, Wholesale Buyer
 and Seller of
CUT FLOWERS
 Open from 5 a. m. to 6 p. m. Sunday
 till 10 a. m.
 Tel., 5243 and 2921 Madison Sq. Res., 345 J., Newtown.
Finest Lilies in the Market Every Day in the Year.

WHOLESALE COMMISSION FLORIST
J. K. ALLEN 106 W. 28 ST.
 NEW YORK
 Telephone 167
 Madison Sq.
 OPEN 6 A.M. DAILY
 We have a good regular outlet for seasonable flowers

NEW YORK QUOTATIONS PER 100—TO DEALERS ONLY

	Last Half of Week ending June 6 1908	First Half of Week beginning June 8 1908		Last Half of Week ending June 6 1908	First Half of Week beginning June 8 1908
Roses			Cattleyas	25.00 to 57.00	25.00 to 50.00
Am. Beauty, fan and sp.	6.00 to 15.00	6.00 to 15.00	Lilies	3.00 to 5.00	3.00 to 5.00
" extra	5.00 to 6.00	5.00 to 6.00	Lily of the Valley.....	1.00 to 3.00	1.00 to 3.00
" No. 1.....	2.00 to 4.00	2.00 to 4.00	Daisies.....	.25 to .50	.25 to .50
" Lower grades50 to 1.00	.50 to 1.00	Pansies.....	.15 to .50	.25 to .50
Bride, 'Maid, fan and sp.	3.00 to 5.00	3.00 to 5.00	Peonies	1.00 to 6.00	1.00 to 6.00
" lwr. grds.....	.50 to 1.00	.50 to 1.00	Gladioli	4.00 to 8.00	4.00 to 8.00
Killarney, Richmond, fancy & spec	3.00 to 6.00	3.00 to 6.00	Lignonette.....	.50 to 1.00	.50 to 1.00
" lower grades.....	.50 to 2.00	.50 to 2.00	Gardenias.....	15.00 to 25.00	15.00 to 25.00
Chatenay, Fancy and Special.....	3.00 to 5.00	3.00 to 5.00	Sweet Peas per 100 bunches.....	3.00 to 6.00	3.00 to 6.00
" Lower grades50 to 2.00	.5 to 2.00	Adiantum25 to .50	.25 to .50
Kaiserin, Carnot.....	.50 to 4.00	.50 to 4.00	Smilax.....	8.00 to 12.00	8.00 to 12.00
Golden Gate, Ivory.....	.50 to 4.00	.50 to 4.00	Asparagus Plumosus, strings....	15.00 to 25.00	15.00 to 25.00
Carnations, Fancy and Novelties.	1.00 to 1.50	1.00 to 1.50	" " & Spren. (100 bchs.)	15.00 to 25.00	15.00 to 25.00
" Ordinary30 to .50	.30 to .50			

Moore, Hentz & Nash,
 Wholesale Commission Florists,
 55 and 57 West 26th Street,
 Telephone No. 756
 Madison Square. **New York.**

TRAENDLY & SCHENCK
WHOLESALE FLORISTS
 Furnish best stock at fair prices all the year round Send for quotations on fall orders
 Tel. 798.799 Madison Sq. 44 West 28th Street, New York City

REED & KELLER
 122 West 25th St., New York
Florists' Supplies
 We manufacture all our
 Metal Designs, Baskets, Wire Work & Novelties
 and are dealers in
 Glassware Decorative Greens and Florists' Requisites

Alexander J. Guttman
THE WHOLESALE FLORIST OF NEW YORK
 34 WEST 28th STREET
 PHONES. 1664--1665 MADISON SQUARE
ENOUGH SAID



HARDY CUT FERNs

Sphagnum Moss, Extra Large Bales, per bale, \$1.25. Fancy and Dagger Ferns our specialty. A trial order will convince you that we ship only first-class stock. Headquarters for Florists' supplies and wire work. All cut flowers in season. **BOXWOOD**, per bunch 35c, 50 lbs. \$7.50.

MICHIGAN CUT FLOWER EXCHANGE, INC., All 'phone connections **38-40 Broadway, Detroit, Mich.**

FANCY and DAGGER

Extra fine, \$1.75 per 1000. Bronze and Green Galax, \$1.25 per 1000. Leucothoe Sprays, \$1.00 per 100, \$7.50 per 1000.

Headquarters in Western New York

FOR **ROSES, CARNATIONS**

And all kinds of Seasonable Flowers

Wm. F. Kasting Co.

Wholesale Commission Florist, also Dealer in Florists' Supplies and Wire Designs.

383-87 ELLICOTT ST. BUFFALO, N. Y.

Give us a trial. We can please you.

Flowers and Florists' Supplies

The best place in AMERICA to buy

BAY TREES

N. F. McCarthy & Co.

84 Hawley St., BOSTON, MASS.

Largest Dealers in Supplies in New England.

SAMUEL A. WOODROW

WHOLESALE PLANTSMAN

Palms, Large and Small Ferns, etc.

53 West 30th Street, NEW YORK

Telephone 2083 Madison

In ordering goods please add "I saw it in HORTICULTURE."

BOSTON FLORIST LETTER CO.
Manufacturers of FLORISTS' LETTERS

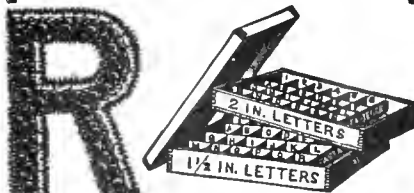

This wooden box nicely stained and varnished, 15x30x12, made in two sections, one for each size letter, given away with first order of 500 letters

Block Letters, 1 1/2 or 2 inch size per 100, \$2. Script Letters, 3. Fastener with each letter or word. Used by leading florists everywhere and for sale by all wholesale florists and supply dealers

N. F. McCARTHY, Manager
66 Pearl Street, BOSTON, MASS.

FRANK S. HICKS & CO.

Wholesale Florists.

Open Now for Consignments of Cut Flowers.

39 West 28th Street, - New York City

Tel. 2920 Mad. Sq.

WILLIAM H. KUEBLER

Brooklyn's Foremost and Best

WHOLESALE COMMISSION HOUSE

A First Class Market for all CUT FLOWERS

28 Willoughby St., Brooklyn, N. Y.

Tel. 4591 Maio



Henry M. Robinson & Co.

Wholesale and Commission

FLORISTS



Hardy Cut Evergreens and Florists' Supplies

NEW CROP DAGGER AND FANCY FERNs, \$2.00 per M.

15 Province St. and 9 Chapman Place, Boston, Mass.

WHOLESALE FLOWER MARKETS. — PER 100. — TO DEALERS ONLY.

	CINCINNATI June 9	DETROIT June 8	BUFFALO June 8	PITTSBURG June 9
ROSES				
Am. Beauty, Fac. and Sp.	20.00 to 25.00	20.00 to 25.00	25.00 to 25.00	18.00 to 25.00
Extra	15.00 to 20.00	15.00 to 18.00	15.00 to 20.00	10.00 to 15.00
No. 1	8.00 to 10.00	8.00 to 15.00	8.00 to 15.00	5.00 to 8.00
Lower grades	4.00 to 6.00	3.00 to 6.00	3.00 to 5.00	2.00 to 3.00
Bride, 'Maid, F. & S.	5.00 to 6.00	6.00 to 8.00	6.00 to 8.00 to 6.00
Low. gr.	2.00 to 4.00	3.00 to 6.00	2.00 to 6.00	2.00 to 5.00
Killarney, Richmond, Fac. & Sp.	6.00 to 8.00	6.00 to 8.00	6.00 to 8.00	5.00 to 8.00
Lower grades	2.00 to 4.00	3.00 to 6.00	2.00 to 6.00	2.00 to 4.00
Chateaux, Fancy and Special	6.00 to 8.00	6.00 to 8.00	6.00 to 8.00	5.00 to 8.00
Lower grades	3.00 to 4.00	3.00 to 6.00	2.00 to 6.00 to 3.00
Kaiserin, Carrot	5.00 to 8.00	4.00 to 8.00	3.00 to 7.00	2.00 to 10.00
Golden Gate, Ivory	5.00 to 8.00	4.00 to 8.00	2.00 to 5.00	5.00 to 8.00
CARNATIONS				
Fancy and Novelties	2.00 to 3.00	3.00 to 4.00	1.50 to 2.00 to 2.00
Ordinary	1.00 to 2.00	2.00 to 3.00	1.00 to 1.50	1.00 to 1.50
MISCELLANEOUS				
Cattleyas	40.00 to 50.00	35.00 to 50.00	40.00 to 50.00 to 50.00
Lilies	8.00 to 10.00	12.50 to	10.00 to 12.00	8.00 to 10.00
Lily of the Valley	3.00 to 4.00	3.00 to 4.00	2.00 to 4.00	3.00 to 4.00
Daisies	.35 to .35	.50 to 1.00	.50 to 1.50	.75 to 1.50
Pansies	.25 to .35	.50 to 1.00	.30 to .50 to .50
Peonies	2.00 to 4.00	4.00 to 8.00	2.00 to 5.00	3.00 to 5.00
Giadoli to 4.00	3.00 to 8.00	3.00 to 5.00	4.00 to 6.00
Mignonette	1.00 to 2.00	1.00 to	1.00 to 2.00	1.00 to 2.00
Gardenias	1.00 to 2.00	15.00 to 25.00	25.00 to 35.00	1.00 to 2.00
Sweet Peas	.50 to .75	.50 to .75	.40 to .75	.75 to .75
Adiantum	.50 to .75	1.00 to 1.50	.50 to 1.50	1.00 to 1.25
Smilax to 1.00	15.00 to 18.00 to 15.00	12.50 to 15.00
Asparagus Plumosus, strig.	40.00 to 50.00	50.00 to 60.00	50.00 to 60.00	30.00 to 50.00
" " & Spre. (100 bchs.) to 25.00	30.00 to 50.00	35.00 to 50.00	30.00 to 40.00

H. G. BERNING

Wholesale Florist

1402 Pine Street, ST. LOUIS, MO.

MILLANG BROS.

WHOLESALE COMMISSION FLORISTS

41 West 28th Street

Telephones 3860 Madison 3861

NEW YORK

A. MOLTZ

Will purchase flowers on order in N. Y. market and ship carefully at prevailing wholesale prices. Address

55-57 West 26th Street, New York City

CLEARY'S HORTICULTURAL CO.

Management AMBROSE T. CLEARY

Wholesale Contracting, Jobbing, Auction

HORTICULTURAL PRODUCTS

of every description.

Consignments Received. Surplus Stock Converted.
62 Vesey St., NEW YORK

In writing to Advertisers kindly mention Horticulture

Buyer's Directory and Ready Reference Guide

Advertisements under this head, one cent a word. Initials count as words.

Regular advertisers in this issue are also listed under this classification without charge. Reference to List of Advertisers will indicate the respective pages.

Buyers failing to find what they want in this list will confer a favor by writing us and we will try to put them in communication with reliable dealers.

ACCOUNTANT

R. J. Dysart, 28 State St., Boston.
For page see List of Advertisers.

ACHYRANTHES.

Floral Hill Gardens, Clatham, N. J.

ALTERNANTHERA

Floral Hill Gardens, Clatham, N. J.

ARAUCARIAS

A. Leuthy & Co., Perkins St. Nurseries, Roslindale, Mass.
For page see List of Advertisers.

ASPARAGUS

A. N. Pierson, Cromwell, Conn.
Asparagus Plumosus Seedlings.
For page see List of Advertisers.

J. M. Thornburn & Co., 33 Barclay St., New York.
Plumosus Nanus and P. Rohustus.
For page see List of Advertisers.

Asparagus plumosus and Sprengerii, 2-in. strong, \$2.25 per 100. J. H. Dann & Son, Westfield, N. Y.

Asparagus Plumosa, 2 in. pots, Pin-plants, \$2.50 per 100; \$20.00 per 1000. Cash with order or good reference. Erie Floral Co., Erie, Pa., or Wm. F. Kasting Co., 385 Elliott St., Buffalo, N. Y.

ASTERS.

Florists' Asters, field grown, Dreeper's Perfection, ready now, \$2.50 per 1000. Celery, tomato, cauliflower, celeriac, parsley, Boston Market lettuce. Write for prices. George Barned, 261 West Putney Street, Corning, N. Y.

Geo. H. Walker, N. Dighton, Mass.

ASTER SEED

Altimo Culture Co., Canfield, O.
For page see List of Advertisers.

AUCTION SALES

Cleary's Horticultural Co., 62 Vesey St., New York.
For page see List of Advertisers.

AZALEAS

A. Leuthy & Co., Perkins St. Nurseries, Roslindale, Mass.
For page see List of Advertisers.

August Rolker & Sons, New York, 31 Barclay St., or P. O. Box 752.
For page see List of Advertisers.

BAMBOO CANES

Yokohama Nursery Co., 31 Barclay Street, New York.
For page see List of Advertisers.

BAY TREES.

N. F. McCarthy & Co., 84 Hawley St., Boston.
For page see List of Advertisers.

2000 Bay and Box Trees in all sizes, Pyramid and Standards. Write for list. Julius Roehrs, Rutherford, N. J.

BEDDING PLANTS

R. Vincent, Jr., & Sons Co., White Marsh, Maryland.
For page see List of Advertisers.

A. N. Pierson, Cromwell, Conn.
For page see List of Advertisers.

A. Leuthy & Co., Perkins St. Nurseries, Roslindale, Mass.
For page see List of Advertisers.

BEDDING PLANTS - Continued

F. R. Pierson Co., Tarrytown-on-Hudson, N. Y.
For page see List of Advertisers.

Vern L. Schuraff, Erie, Pa.
For page see List of Advertisers.

Wm. S. Herzog, Morris Plains, N. J.
Godfrey Aschmann,
1012 W. Ontario St., Phila., Pa.
For page see List of Advertisers.

40,000 geraniums, 10 best standard sorts; 5000 Vinca variegata; Salvia; heliotrope, dark; few-few, double white. Good stock, prices right. E. D. Kaulback & Son, Malden, Mass.

BEGONIAS

Thomas Roland, Nahant, Mass.
Gloire De Lorraine.
For page see List of Advertisers.

S. S. Skidelsky, 1741 N. 18th St., Phila.
Gloire de Lorraine.
For page see List of Advertisers.

Tuberous Begonias, best single, fine tubers, \$1.50 per 100. Schlegel & Fottler Co., 26 South Market St., Boston.

Begonia Gloire Lorraine, strong plants from leaf cuttings, 2 1-4 inch pots, \$12.00 per 100; \$110.00 per 1000. Julius Roehrs, Rutherford, N. J.

BERBERIS THUNBERGII

Oak Hill Nurseries, Roslindale, Mass.

BOILERS

BOILERS. "Burnham" Boilers made for greenhouse heating. Lord & Burnham, 1133 Broadway, N. Y.

Kroeschell Bros. Co., 35 Erie St., Chicago.
For page see List of Advertisers.

BUILDERS' AND FARM LEVELS

Bostrom-Brady Mfg. Co., 139 Madison Ave., Atlanta, Ga.
For page see List of Advertisers.

BUILDING MATERIAL

BUILDING MATERIAL of all description for All Cypress, Semi-Iron, Iron Frame or Truss Houses. Hot Bed Sash and Frames. Lord & Burnham Co., 1133 Broadway, N. Y.

BULBS AND TUBERS

Joseph Breck & Sons, 47-54 N. Market St., Boston.
For page see List of Advertisers.

J. M. Thornburn & Co., 33 Barclay St., New York.
For page see List of Advertisers.

A. T. Boddington, 342 W. 14th St., N. Y.
For page see List of Advertisers.

Rickards Bros., 37 East 19th St., New York.
For page see List of Advertisers.

H. F. Mitchell Co., Philadelphia.
For page see List of Advertisers.

H. E. Fiske Seed Co., Fanenl Hall Bq., Boston.
For page see List of Advertisers.

James Vick's Sons, Rochester, N. Y.
Fall Bulbs.
For page see List of Advertisers.

Aug. Rolker & Sons, 31 Barclay St., New York.
Seasonable Import Plants and Bulbs.
For page see List of Advertisers.

K. Velthuys, Hillegom, Holland,
Represented by Felix Bosch, 260 Clarendon St., Boston.
Bulbs French and Dutch.
For page see List of Advertisers.

BULBS AND TUBERS - Continued

A. Mitting, 17-23 Kennan St., Santa Cruz, California.
Calla Bulbs.
For page see List of Advertisers.

CANNAS

The Conard & Jones Co., West Grove, Pa.
For page see List of Advertisers.
Godfrey Aschmann,
1012 W. Ontario St., Phila., Pa.
For page see List of Advertisers.

E. & C. Woodman, Danvers, Mass.
For page see List of Advertisers.

The F. R. Pierson Co., Tarrytown-on-Hudson, N. Y.
For page see List of Advertisers.

Frank Cummings Bulb & Plant Co., Meridian, Miss.
Estate of David Fisher, Woburn, Mass.

CARE OF TREES

H. L. Frost & Co., White Plains, N. Y.;
Arlington, Mass.

CARNATIONS

F. Dorner & Sons Co., Lafayette, Ind.
For page see List of Advertisers.

Chicago Carnation Co., Joliet, Ill.
For page see List of Advertisers.

John E. Haines, Bethlehem, Pa.
Carnations Imperial and Pink Imperial.
For page see List of Advertisers.

A. N. Pierson, Cromwell, Conn.
For page see List of Advertisers.

The F. R. Pierson Co., Tarrytown-on-Hudson, N. Y.
For page see List of Advertisers.

H. F. Littlefield, 552 Main St., Worcester, Mass.

Albert Roper, Tewksbury, Mass.
Carnation Bay State.
For page see List of Advertisers.

Carnation cuttings of all the leading varieties at the same price as any reliable firm. Write for prices before you look elsewhere. Wm. F. Kasting Co., 385 Elliott St., Buffalo, N. Y.

CARNATIONS' FIELD GROWN? Enchantress and Winsor, on and after July 1st. Only a few left. To close out quick, 85¢ a thousand. Cash or good reference with order. Wanaka Greenhouses, Barneveld, N. Y.

CAULIFLOWER AND CABBAGE SEED

H. Hartmann & Co., Copenhagen, Denmark.
For page see List of Advertisers.

CHRYSANTHEMUMS

Chas. H. Totty, Madison, N. J.
For page see List of Advertisers.

A. N. Pierson, Cromwell, Conn.
For page see List of Advertisers.

H. F. Littlefield, 552 Main St., Worcester, Mass.
Rooted Cuttings.

H. L. Cameron, No. Cambridge, Mass.
Herrington's book on the Chrysanthemum, mailed to your address for 50c., by Horticulture Publishing Co., 11 Hamilton Place, Boston.

Chrysanthemums ready; 2 1-2 inch strong stock of Touse, Oct. Frost, Polly Rose, Wanamaker, and all standards, \$2 per 100, \$18 per M. New; 2 1-2, strong, Alice Roosevelt, Hanker, Clay Frick, Winter Cheer, Rosette, B. May, \$4 per 100, \$30 per M. Cash. Send for catalog. Harlowarden Greenhouses, Greenport, N. Y.

For List of Advertisers See Page 805

CHRYSANTHEMUMS — Continued

Have 100,000 fine young well-rooted 'Mums, cuttings of the best 60 commercial varieties. Send for our new and low price list. Satisfaction guaranteed. Wm. Ehmann, Jr., Corfu, N. Y.

COBAEAS

Cobaen scandens from 4 in. pots, \$8.00 per 100. Wittbold Co., 1657 Buckingham Place, Chicago, Ill.

COLEUS

A. N. Pierson, Cromwell, Conn.
For page see List of Advertisers.
Coleus, Vorsch, and fine assorted, 2 in., strong, 2c. Cash. L. E. Marquisee, Syracuse, N. Y.

CONIFERS

John Waterer & Sons, Ltd., American Nursery, Bagshot, Eng.
For page see List of Advertisers.

CUT FLOWER BOXES.

Edwards Folding Box Co., Philadelphia.
For page see List of Advertisers.
Folding cut flower boxes, the best made. Write for list. Holton & Hunkel Co., Milwaukee, Wis.

CYCLAMEN.

Cyclamen, finest Giant strain, separate colors, once transplanted seedlings, 2c.; twice transplanted, 3c.; strong, from 2-in. pots, 4c. J. I. Schiller, 929 Prouty Ave., Toledo, O.

DAHLIAS

David Herbert & Son, Atco, N. J.
For page see List of Advertisers.
R. Vincent, Jr. & Sons Co., White Marsh, Maryland.
For page see List of Advertisers.

Dahlias, balance of season, 25 named varieties, postpaid, \$1.00. Catalogue free. J. L. Moore, Northboro, Mass.

Dahlias: About 2000 Cath. Duer, Kriemhilde, Brunhilde, Snowlad, etc., \$3 per 100. Cash. Harlowarden Greenhouses, Greenport, N. Y.

DECORATIVE PLANTS

A. Leuthy & Co., Perkins St. Nurseries, Roslindale, Mass.
For page see List of Advertisers.
Godfrey Aschmann,
1012 W. Ontario St., Phila., Pa.
For page see List of Advertisers.

DRACAENAS

E. & C. Woodman, Danvers, Mass.
For page see List of Advertisers.
Dracaena indivisa: 4 in., \$2.00 per doz., \$12.00 per 100; 5 in., \$3.00 per doz., \$20.00 per 100. Wittbold Co., 1657 Buckingham Place, Chicago, Ill.

ECHEVERIAS

Echeverias, \$18 per 1000, post paid. McDowell, Mexico City.

ELECTRIC CIRCULATOR

The Castle Co., 170 Summer St., Boston.
For page see List of Advertisers.

FERNS

A. Leuthy & Co., Roslindale, Mass.
For page see List of Advertisers.
H. H. Barrows & Son, Whitman, Mass.
Nephrolepis Whitman.
For page see List of Advertisers.
John Scott, Brooklyn, N. Y.
For page see List of Advertisers.
The F. R. Pierson Co., Tarrytown-on-Hudson, N. Y.
For page see List of Advertisers.

FERNS FOR JARDINIERES

Frank N. Eskosen, Madison, N. J.
For page see List of Advertisers.

FERTILIZERS

Pulverized Manure Co., 31 Union Stock Yards, Chicago, Ill.
Wizard Brand Cattle Manure.
For page see List of Advertisers.
Thos. J. Grey & Co.,
32 and 33 South Market St., Boston.
High-Grade Scotch Soot.
For page see List of Advertisers.

FERTILIZERS — Continued

Wm. Elliott & Sons, 42 Vesey St., New York.
Sterilized Sheep Manure.
For page see List of Advertisers.

FLORAL PHOTOGRAPHS

Floral Photographs. Foley's 226-228 1-2 Bowery, New York.

FLORISTS' BASKETS

E. H. Hitchcock, Glenwood, Mich.
For page see List of Advertisers.

FLORISTS' LETTERS.

Boston Florist Letter Co., 66 Pearl St., Boston, Mass.
For page see List of Advertisers.

FLORISTS SUPPLIES

N. F. McCarthy & Co., 84 Hawley St., Boston.
For page see List of Advertisers.
A. M. Robinson & Co., 15 Province St. and 9 Chapman Pl., Boston, Mass.
For page see List of Advertisers.

Keed & Keller, 122 W. 25th St., New York.
For page see List of Advertisers.

J. B. Mudooh & Co., 714 Penn Ave., Pittsburg, Pa.
For page see List of Advertisers.

H. Bayersdorfer & Co., 1129 Arch St., Philadelphia.
For page see List of Advertisers.

FLOWERS BY TELEGRAPH

Park Floral Co., Denver, Colo.
For page see List of Advertisers.
J. N. Champlin & Co., 1026 Chapel St., New Haven, Conn.
For page see List of Advertisers.

Gude Bros. Co., 1214 F St., Washington, D. C.
For page see List of Advertisers.

Atlanta Floral Co., Atlanta, Ga.
For page see List of Advertisers.

M. C. & J. E. Hauswirth, 232 Michigan Ave., Chicago.
For page see List of Advertisers.

William J. Smyth, Michigan Ave. and 31st St., Chicago.
For page see List of Advertisers.

George Wittbold Co., 1657-59 Buckingham Place, Chicago.
For page see List of Advertisers.

Jacob Schulz, 644 4th Ave., Louisville, Ky.
For page see List of Advertisers.

Thos. F. Galvin, 124 Tremont St., Boston.
For page see List of Advertisers.

Julius A. Zinn, 2 Beacon St., Boston.
For page see List of Advertisers.

Houghton & Clark, 396 Boylston St., Boston.
For page see List of Advertisers.

Sidney Hoffman, 59-61 Massachusetts Ave., Boston.
For page see List of Advertisers.

Edward MacMulklin, 194 Boylston St., Boston.
For page see List of Advertisers.

J. Breitmeyer's Sons, Miami and Gratiot Aves., Detroit, Mich.
For page see List of Advertisers.

Samuel Murray, 1017 Broadway, Kansas City, Mo.
For page see List of Advertisers.

Wm. L. Rock Flower Co., 1116 Walnut St., Kansas City, Mo.
For page see List of Advertisers.

Fred C. Weber, 4326-28 Olive St., St. Louis, Mo.
For page see List of Advertisers.

H. G. Eyres, 11 N. Pearl St., Albany, N. Y.
For page see List of Advertisers.

David Clarke's Sons, 2159-2141 Broadway, New York.
For page see List of Advertisers.

Alex. McConnell, New York.
For page see List of Advertisers.

Robert G. Wilson, Fulton St. & Greene Av., Brooklyn, N. Y.
For page see List of Advertisers.

Young & Nugent, 42 W. 28th St., N. Y.
For page see List of Advertisers.

J. H. Dunlop, 96 Yonge St., Toronto, Can.
For page see List of Advertisers.

FLOWER BOXES

Illinois Heater & Mfg. Co., 3946 Wentworth Ave., Chicago, Ill.
Self Watering for Windows, Porches and Cemeteries.
For page see List of Advertisers.

FLOWER POTS

W. H. Ernest, 28th and M Sts., Washington, D. C.
For page see List of Advertisers.
A. H. Hews & Co., Cambridge, Mass.
For page see List of Advertisers.
Hilfinger Bros., Ft. Edward, N. Y.
For page see List of Advertisers.
Ired pots, seed pans, etc.
The Peters & Reed Pottery Co., Zanesville, O.

GALAX

Michigan Cut Flower Co., 38 and 40 Broadway, Detroit, Mich.
For page see List of Advertisers.

GERANIUMS

R. Vincent Jr. & Sons Co., White Marsh, Md.
New and Standard Varieties.
For page see List of Advertisers.

Godfrey Aschmann,
1012 W. Ontario St., Phila., Pa.
For page see List of Advertisers.

Wm. W. Edgar Co., Waverly, Mass.
For page see List of Advertisers.

H. L. Cameron, No. Cambridge, Mass.
3000 Nutt Geraniums, in bloom, 4 in., \$5.00 per 100. 500 mixed Coleus, 2 1/2 in., \$2.00 per 100. Would trade for carnations. Joseph Croucher, 1805 West Third Street, Chester, Pa.

Geraniums, 2-in., double red, \$1.50 per 100. J. H. Dann & Son, Westfield, N. Y.

GLADIOLI

Gladiolus, large flowering mixed, balance of season, \$1.00 per 100; postpaid. J. L. Moore, Northboro, Mass.

GLASS

Boston Plate & Window Glass Co., Boston.
For page see List of Advertisers.

Standard Plate Glass Co., 26-30 Sudbury St., Boston.
For page see List of Advertisers.

S. Jacobs & Sons, 1365-79 Flushing Ave., Brooklyn, N. Y.
For page see List of Advertisers.

Metropolitan Material Co., 1398-1408 Metropolitan Ave., Brooklyn, N. Y.

Foley Mfg. Co., Western Ave., between 25th & 26th Sts., Chicago.

Sharp, Partridge & Co., 22d & Lumber St., Chicago.
For page see List of Advertisers.

Greenhouse glass, lowest prices. Johnston Glass Co., Hartford City, Ind.

GLASS, High Grade, Double Thick Greenhouse Glass. Lord & Burnham, 1133 Broadway, N. Y.

GLAZING POINT

H. A. Dreer, Philadelphia, Pa.
For page see List of Advertisers.

GLAZING POINTS, Lord & Burnham Special Glazing Nails (Points). Lord & Burnham, 1133 Broadway, N. Y.

GREENHOUSE BUILDING MATERIAL

Lord & Burnham Co.,
1133 Broadway, New York.
For page see List of Advertisers.

Pierson U-Bar Co., 1 Madison Sq., N. Y.
For page see List of Advertisers.

A. T. Stearns Lumber Co., Neponset, Boston.
For page see List of Advertisers.

King Construction Co., N Tonawanda, New York.
For page see List of Advertisers.

J. C. Moninger Co., 117 East Blackhawk St., Chicago, Ill.
For page see List of Advertisers.

Foley Mfg. Co., Western Ave., between 25th & 26th Sts., Chicago.
For page see List of Advertisers.

In writing to Advertisers kindly mention Horticulture

GREENHOUSE BUILDING MATERIAL - Continued

- I. Cassidy, Summer Ave. and Erie R. R., Newark, N. J.
For page see List of Advertisers.
- Geo. B. Doane, 18 Midway St., Boston, Iron Pipe.
For page see List of Advertisers.
- S. Jacobs & Sons, 1365-79 Flushing Ave., Brooklyn, N. Y.
For page see List of Advertisers.
- Wm. H. Lutton, West Side Avenue Sta., Jersey City, N. J.
For page see List of Advertisers.
- Metropolitan Material Co., 1398-1408 Metropolitan Ave., Brooklyn, N. Y.

GREENHOUSE CONSTRUCTION

- GREENHOUSE CONSTRUCTION**, Semi Iron Greenhouse, New Truss Houses and Iron Frame Houses. Lord & Burnham, 1133 Broadway, N. Y.
- J. A. Payne, 260-274 Culver Ave., Jersey City, N. J.
For page see List of Advertisers.
- I. Cassidy, Summer Ave. and Erie R. R., Newark, N. J.
For page see List of Advertisers.
- Foley Mfg. Co., Western Ave., between 25th & 26th Sts., Chicago.
For page see List of Advertisers.
- Wm. H. Lutton, West Side Avenue Sta., Jersey City, N. J.
Curved Iceless Eave.
For page see List of Advertisers.
- The Weathered Co., New York City.
For page see List of Advertisers.

GUTTERS

- GUTTERS, Cast Iron Gutters, L. & B. Improved V Shaped Gutter with drip gutter attachment. Lord & Burnham, 1133 Broadway, N. Y.

HAIL INSURANCE

- Florists' Hall Asso. of America.
J. G. Esler, Saddle River, N. J.
For page see List of Advertisers.

HARDY FERNS AND SUPPLIES

- H. M. Robinson & Co., 15 Province St. and 9 Chapman Pl., Boston, Mass.
For page see List of Advertisers.
- Michigan Cut Flower Exchange, 38 and 40 Broadway, Detroit, Mich.
Fancy Ferns.
For page see List of Advertisers.

HART'S HANDY HANDLE

- Geo. B. Hart, 24 Stone St., Rochester, N. Y.
For page see List of Advertisers.

HEATING APPARATUS

- Lord & Burnham Co., 1133 Broadway, New York.
For page see List of Advertisers.
- Pierson U-Bar Co., 1 Madison Sq., N. Y.
For page see List of Advertisers.
- John A. Payne, 260-274 Culver Ave., Jersey City, N. J.
For page see List of Advertisers.
- Kriechell Bros. Co., 25 Erie St., Chicago
For page see List of Advertisers.

HEDGE PLANTS

- Peter's Nursery, Knoxville, Tenn.

HELP FURNISHED

- Thos. H. Bambrick, 34 S. 7th St., Phila.
For page see List of Advertisers.

HERBACEOUS PERENNIALS

- Bay State Nurseries, No. Abington, Mass.
For page see List of Advertisers.
- P. Ouwerkerk, P. O. No. 2, Hoboken, N. J.
For page see List of Advertisers.

HOSE

- Henry A. Drees, 714 Chestnut St., Phila.
Riverton Hose.
For page see List of Advertisers.

HOT-BED SASH

- The A. T. Stearns Lumber Co., Neponset, Mass.
For page see List of Advertisers.
- Pierson U-Bar Co., 1 Madison Sq., N. Y.
For page see List of Advertisers.
- Lord & Burnham Co., 1133 Broadway, N. Y.
For page see List of Advertisers.

HOT-BED SASH - Continued

- Foley Mfg. Co., Western Ave., between 25th & 26th Sts., Chicago.

HYDEANGEAS.

- W. W. Edgar Co., Waverley, Mass.
For page see List of Advertisers.
- F. R. Pierson Co., Tarrytown-on-Hudson, N. Y.
Hydrangea Otaksa.
For page see List of Advertisers.

INSECTICIDES.

- Nicotine kills all greenhouse pests.
P. R. Palethorpe Co., Eleventh St., Owensboro, Ky.
For page see List of Advertisers.

IRISES

- J. M. Thorburn & Co., 33 Barclay St., New York.
For page see List of Advertisers.

JAPANESE PLANTS

- Yokohama Nursery Co., 31 Barclay St., New York.
For page see List of Advertisers.

JUMPING BEANS

- Jumping Beans, \$5 per 1000, post paid.
McDowell, Mexico City.

KENTIAS

- A. Leathy & Co., Roslindale, Mass.
For page see List of Advertisers.
- Jos. Hancock Co., Wyncote, Pa.
For page see List of Advertisers.

LILIES - Cut Blooms

- Lilies, large, pure white, fragrant, 40 cents per bud and bloom, large or small lots. E. M. Dealls, Florist, 43 Whiting St., Lynn, Mass. Tel. 505 B.

LOBELIAS

- Double Lobelia, Kathleen Mallard, 2 1/2 in., 4c. Strong cuttings from soil, all full of buds and bloom. J. L. Stone, Trumansburg, N. Y.

MARGUERITE CARNATIONS

- Geo. H. Walker, N. Dighton, Mass.

MASTICA

- F. O. Pierce Co., 12 W. Broadway, New York.
For page see List of Advertisers.

MOON VINES

- Godfrey Aschmann, 1012 W. Ontario St., Philadelphia.
For page see List of Advertisers.

MYRTLE

- Myrtle for cemetery planting, strong field grown clumps, \$2.00 per 100, or \$17.50 per 1000. Geo. A. Dhomau, East Walnut Hills, Cincinnati, O.

NEW AND RARE PLANTS

- Rose Hill Nurseries, New Rochelle, N. Y.
For page see List of Advertisers.

NICO-FUME

- Kentucky Tobacco Product Co., Louisville, Ky.

NURSERY STOCK

- John Waterer & Sons, Ltd., American Nursery, Bagshot, England.
For page see List of Advertisers.
- Bay State Nurseries, N. Abington, Mass.
Herbaceous Perennials, Hardy Ornamental Trees.
For page see List of Advertisers.
- Clery's Horticultural Co., 62 Vesey St., New York.
For page see List of Advertisers.
- P. Ouwerkerk, 218 Jane St., Weehawken, Heights, N. J.
Holland Nursery Stock for Forcing.
For page see List of Advertisers.
- American Nursery Co., 150 Broadway, New York, N. Y.
For page see List of Advertisers.
- Peter's Nursery Co., Knoxville, Tenn.
Live Fences; Amoor and California Privet.

ORCHID PLANTS

- Lager & Hurrell, Summit, N. J.
For page see List of Advertisers.
- Saunders, St. Albans, England.
Importers, Exporters, Growers, Hybridists
For page see List of Advertisers.
- Julius Roehrs Co., Rutherford, N. J.
For page see List of Advertisers.
- Carrillo & Baldwin, Secaucus, N. J.
For page see List of Advertisers.
- Jos. A. Manda, 191 Valley Road, W. Orange, N. J.
For page see List of Advertisers.
- Ordonez Bros., Madison, N. J., Box 106.
For page see List of Advertisers.
- Largest stock in the country. Ask for prices. Julius Roehrs, Rutherford, N. J.

PALMS

- A. Leathy & Co., Perkins St. Nurseries, Roslindale, Mass.
For page see List of Advertisers.
- Robert Craig Co., Market and 49th Sts., Philadelphia, Pa.
For page see List of Advertisers.
- August Rolker & Sons, 31 Barclay St., New York.
For page see List of Advertisers.
- Joseph Hancock Co., Wyncote, Pa.
Home-Grown Palms.
For page see List of Advertisers.

PAINT AND PUTTY

- PAINT AND PUTTY:** Ideal Greenhouse lead; Special Greenhouse Putty. Lord & Burnham, 1133 Broadway, N. Y.

PATENTS

- Siggers & Siggers, Washington, D. C.
For page see List of Advertisers.

PEAT

- Orchid peat, Rotted peat, Azalea peat, Leaf-Mould, Live Sphagnum moss, Baled Sphagnum moss, Green Clump moss, etc. Jobbers' list on application. C. W. Brownell & Co., Walden, N. Y.

PELARGONIUMS

- R. Vincent, Jr. & Sons Co., White Marsh, Maryland.
For page see List of Advertisers.

PEONIES

- Wholesale Peony list for fall 1908 is now ready. J. F. Rosenfield, West Point, Neb.
- One of the finest collections in America. Send 25 cts. in stamps for new edition of Peony Manual. C. S. Harrison's Select Nursery, York, Neb.

PETUNIAS

- Star Petunias from 2 in. pots, fine, clean plants, \$2.00 per 100, \$18.00 per 1000. W. E. Hall, Clyde, O.

PHLOXES

- Send 25 cts. in stamps for Phlox Manual. Fine mixed phloxes \$1.50 per 100. C. S. Harrison's Select Nursery, York, Neb.

PIPE AND FITTINGS

- Foley Mfg. Co., between Western Ave. and 26th St., Chicago, Ill.
For page see List of Advertisers.

- Kriechell Bros. Co., 25 Erie St., Chicago.
For page see List of Advertisers.

- PIPE AND FITTINGS:** Cast Iron and Wrought Pipe, Valves, Elbows, Pipe Hooks, Automatic Air Headers, etc. Lord & Burnham, 1133 Broadway, N. Y.

PLANT STAKES AND TRELLISES

- Seale's Patent, for roses, chrysanthemums, gladioli, tuberoses, dahlias, tomatoes, egg plants, etc. H. D. Seale & Sons, Manuf., Elkhart, Ind.

PLANT TUBS

- H. A. Drees, 714 Chestnut St., Phila

For List of Advertisers See Page 805

POT HANGERS

Pot hangers, Kramer's \$1 doz. by exp., \$1.25 by mail. I. N. Kramer & Son, Cedar Rapids, Ia.

PRIMULA SEED

H. E. Fiske Seed Co., 13 Faneuil Hall Sq., Boston.
For page see List of Advertisers.

O. V. Zangen, Hoboken, N. J.
For page see List of Advertisers.

RAFFIA

Raffia (colored), 20 beautiful shades. Samples free. R. H. Conroy Co., Camden, N. J.; 810 Washburn Ave., Chicago, Ill.

RETAIL FLORISTS

Park Floral Co., Denver, Colo.
For page see List of Advertisers.

Gude Bros. Co., 1214 F St., Washington, D. C.
For page see List of Advertisers.

Atlanta Floral Co., Atlanta, Ga.
For page see List of Advertisers.

M. C. & J. E. Hauswirth, 232 Michigan Ave., Chicago.
For page see List of Advertisers.

William J. Smyth, Michigan Ave. and 31st St., Chicago.
For page see List of Advertisers.

George Wittbold Co., 1657-59 Buckingham Place, Chicago.
For page see List of Advertisers.

Jacob Schulz, 644 4th Ave., Louisville, Ky.
For page see List of Advertisers.

Thos. F. Galvin, 124 Tremont St., Boston.
For page see List of Advertisers.

Julius A. Zinn, 2 Beacon St., Boston.
For page see List of Advertisers.

Houghton & Clark, 396 Boylston St., Boston.
For page see List of Advertisers.

Sidney Hoffman, 59-61 Massachusetts Ave., Boston.
For page see List of Advertisers.

Edward MacMullin, 194 Boylston St., Boston.
For page see List of Advertisers.

J. Bretmeyer's Sons, Detroit, Mich.
For page see List of Advertisers.

Samuel Murray, 1017 Broadway, Kansas City, Mo.
For page see List of Advertisers.

Wm. L. Rock Flower Co., 1116 Walnut St., Kansas City, Mo.
For page see List of Advertisers.

Fred C. Weber, 4326 Olive St., St. Louis, Mo.
For page see List of Advertisers.

J. N. Champion & Co., 1026 Chapel St., New Haven, Conn.
For page see List of Advertisers.

H. G. Eyres, 11 N. Pearl St., Albany, N. Y.
For page see List of Advertisers.

David Clarke's Sons, 2139-2141 Broadway, New York.
For page see List of Advertisers.

Alex. McConnell, New York.
For page see List of Advertisers.

Robert G. Wilson, Fulton St. and Greene Ave., Brooklyn, N. Y.
For page see List of Advertisers.

Young & Nugent, 42 W. 28th St., N. Y.
For page see List of Advertisers.

J. H. Dunlop, 96 Youze St., Toronto, Can.
For page see List of Advertisers.

RHODODENDRONS

John Waterer & Sons, Ltd., American Nursery, Bagshot, England.
For page see List of Advertisers.

P. Ouwerkerk, Hoboken, N. J.
For page see List of Advertisers.

Eastern Nurseries, Jamaica Plain, Mass. Hardy Hybrid and Dwarf Rhododendrons.
For page see List of Advertisers.

ROSES

Bay State Nurseries, N. Abington, Mass.
For page see List of Advertisers.

Robert Craig Co., Market and 49th Sts., Philadelphia, Pa.
For page see List of Advertisers.

ROSES - Continued

Dingee-Conard Co., West Grove, Pa.
For page see List of Advertisers.

R. & J. Farquhar & Co., 6 and 7 South Market Street, Boston.
For page see List of Advertisers.

The E. G. Hill Co., Richmond, Ind. Roses, Rhea Keld, American Beauty.
For page see List of Advertisers.

Poehlmann Bros. Co., Morton Grove, Ill. Mrs. Potter Palmer, Cardinal, Beauty.
For page see List of Advertisers.

P. R. Quinlan, Syracuse, N. Y. Killarney, Richmond, Bridesmaids.
For page see List of Advertisers.

P. Ouwerkerk, P. O. No. 2, Hoboken, N. J.
For page see List of Advertisers.

Low-budded roses, No. 1, \$95.00; No. 1-2, \$65.00 1000. H. T. Jones, Elizabeth, N. J.

S. A. F. CONVENTION ACCOMMODATIONS

Tower Hotel, Niagara Falls, N. Y.
For page see List of Advertisers.

SALVIAS

Cohanzie Carnation Co., New London, Ct. Salvia Splendens.
For page see List of Advertisers.

SEEDS

T. J. Grey Co., 32 So. Market St., Boston, Mass.
For page see List of Advertisers.

Joseph Breck & Sons, 51 and 52 N. Market St., Boston, Mass.
For page see List of Advertisers.

W. Atlee Burpee & Co., Philadelphia.
For page see List of Advertisers.

J. M. Thorburn & Co., 33 Barclay St., N. Y.
For page see List of Advertisers.

Arthur T. Boddington, 342 W. 14th St., New York.
Sweet Peas for Thanksgiving and Christmas.
For page see List of Advertisers.

H. F. Michell Co., 1017 Market St., Phila.
For page see List of Advertisers.

James Vick's Sons, Rochester, N. Y. Vick's Superb Pansy Seed.
For page see List of Advertisers.

Hjalmar Hartmann & Co., 12 Stormgade, Copenhagen, Denmark. Cauliflower and Cabbage Seed.
For page see List of Advertisers.

Rickards Bros., 37 E. 19th St., New York.
For page see List of Advertisers.

R. & J. Farquhar & Co., 6-7 So. Market St., Boston.
For page see List of Advertisers.

Braslan Seed Growers Co., San Jose, Cal.
For page see List of Advertisers.

H. E. Fiske Seed Co., Faneuil Hall Bq., Boston.
Primula Fringed Sinensis.
For page see List of Advertisers.

O. V. Zangen, Hoboken, N. J.
For page see List of Advertisers.

John F. Rupp, Shiremanstown, Pa. Chinese Primrose, Chimeraria, Giant Pansy Seeds.
For page see List of Advertisers.

SMILAX

Smilax, choice young plants from fall; \$3.00 per 1000, 2000 for \$5.00, 5000 for \$10.00; 50c. per 100 by mail. F. A. Baller, Bloomington, Ill.

Smilax, strong, 2-4 in. pots, \$1.75 per 100; \$15.00 per 1000. Seedlings, 25 cents per 100; \$2.00 per 1000. Wm. Livesey, Methen, St., New Bedford, Mass.

SPHAGNUM MOSS

Live Sphagnum moss, orchid peat and orchid baskets always on hand. Lager & Hurrell, Summit, N. J.

SPRAYERS

Charles J. Jager Co., 281-85 Franklin St., Boston.

"SHOWERMAKER," St. Jos. Kopesay, So. Bond, Ind.

STEAM TRAP

E. Hippard, Youngstown, O.

SWEET PEAS

A. C. Zvolanek, Round Brook, N. J. Winter Flowering.
For page see List of Advertisers.

TO-BAK-INE

E. H. Hunt, Genl. Agt., 76-78 Wabash Av., Chicago.
For page see List of Advertisers.

TUBEROSES

Stump & Walter Co., 59 Barclay St., New York.
For page see List of Advertisers.

No. 1 Pearl Tuberose bulbs, \$5.00 per 100. Schlegel & Fottier Co., 26 South Market St., Boston.

VEGETABLE PLANTS

R. Vincent, Jr. & Sons Co., White Marsh, Maryland.
For page see List of Advertisers.

W. W. Edgar Co., Waverley, Mass. Tomato Plants.
For page see List of Advertisers.

VENTILATING APPARATUS

Pierston U-Bar Co., 1 Madison Sq., N. Y.
For page see List of Advertisers.

Foley Mfg. Co., Western Ave., between 25th & 26th Sts., Chicago.
For page see List of Advertisers.

John A. Payne, 260-274 Culver Ave., Jersey City, N. J.
For page see List of Advertisers.

The Advance Co., Richmond, Ind.
For page see List of Advertisers.

Quaker City Machlue Co., Richmond, Ind. 20th Century Ventilating Arm.
For page see List of Advertisers.

VENTILATING MACHINERY. New Model encased, self-oiling gear; Standard Model Open Gear. Lord & Burnham, 1133 Broadway, N. Y.

VERBENAS

Cohanzie Carnation Co., New London, Conn. Lemon Verbea.
For page see List of Advertisers.

VIOLETS.

Lady Campbell violets, 25,000 extra fine, sand-rooted cuttings, \$1.00 per 100, by mail; \$7.00 per 1000, by express; 500 at 1000 rate. Satisfaction guaranteed. Field-grown plants of Campbell and California ready in August. Chas. Black, Hightstown, N. J.

Maria Louise and Farquhar violet plants, strong, February and March sand struck, clean and free from disease, \$2.00 per 100; \$15.00 per 1000. Will be ready May 15. Cash with order, please. C. Lawritzen, Box 261 Rhinebeck, N. Y.

How to Make Money Growing Violets, will be sent postpaid for 25c. by Horticulture Publishing Co., 11 Hamilton Place, Boston.

Violet cuttings, "Maria Louisa" Rhinebeck stock, rooted runners, May delivery \$20.00 M. Wm. E. Kasting Co., 383 Elliott St., Buffalo, N. Y.]

Commercial Violet Culture, by B. T. Galloy, sent postpaid for \$1.50, by Horticulture Publishing Co., 11 Hamilton Place, Boston.

VINCAS

H. C. Woodman, Danvers, Mass.
For page see List of Advertisers.

Amor. var., also green, extra heavy 1 1/2 in., 1 5/8; 2 1/2 in., good, 2c. Cash. L. F. Marquissee, Syracuse, N. Y.

In writing to Advertisers kindly mention Horticulture

WIRED TOOTHPICKS

W. J. Cowee, Berlin, N. Y.
For page see List of Advertisers.

WIREWORK

Reed & Keller, 122 W. 25th St., N. Y.
For page see List of Advertisers.
Wirework. Write for our catalogue.
Holton & Hunkel Co., Milwaukee, Wis.
William E. Helescher's Wire Works, 38-40
Broadway, Detroit, Mich.
Headquarters for wire work. Send for
list. Ball & Betz, 31 E. 3rd St., Cin-
cinnati, O.

WHOLESALE FLORISTS**Boston**

N. F. McCarthy & Co., 84 Hawley St.,
Boston.
For page see List of Advertisers.
H. M. Robinson & Co., 15 Province St.
and 9 Chapman Pl., Boston.
For page see List of Advertisers.
Welch Bros., 226 Devonshire St., Boston.
For page see List of Advertisers.

Buffalo

Wm. F. Knsting Co., 383-87 Billcott St.,
Buffalo, N. Y.
For page see List of Advertisers.

Chicago

Chas. W. McKellar, 51 Wabash Ave.,
Chicago.
For page see List of Advertisers.
Peter Reinberg, 51 Wabash Ave., Chicago.
For page see List of Advertisers.
E. F. Winterson Co., 45-49 Wabash Ave.,
Chicago.
For page see List of Advertisers.
J. A. Budlong, 37-39 Randolph St., Chicago.
For page see List of Advertisers.

Detroit

Michigan Cut Flower Exchange, 38 and 40
Broadway, Detroit, Mich.
For page see List of Advertisers

Minneapolis

Rice Bros., 115 N. 6th St., Minneapolis,
Minn.
For page see List of Advertisers.

New York

J. K. Allen, 106 W. 28th St., New York
For page see List of Advertisers.
J. S. Fenrich, 110 W. 28th St., New York.
For page see List of Advertisers.
Ford Bros., 48 W. 28th St., New York
For page see List of Advertisers.
H. E. Froment, 57 W. 28th St., New York.
For page see List of Advertisers.
Alex. J. Guttman, 34 W. 28th St., New
York.
For page see List of Advertisers.
E. C. Horan, 53 W. 28th St., New York
For page see List of Advertisers.
A. H. Langjahr, 55 W. 28th St., New York
For page see List of Advertisers.
James McManus, 42 W. 28th St., New York
For page see List of Advertisers.
John I. Raynor, 49 W. 28th St., New York.
For page see List of Advertisers.
W. F. Sheridan, 39 W. 28th St., New York
For page see List of Advertisers.
Trendly & Scheuck, 44 W. 28th St., New
York.
For page see List of Advertisers
John Young, 51 W. 28th St., New York
Moore, Hentz & Nssh, 55 and 57 W. 28th
St., New York.
For page see List of Advertisers.
Frank S. Hicks & Co., 39 W. 28th St.,
New York.
For page see List of Advertisers.
Wm. H. Kuehler, 28 Willoughby St.,
Brooklyn, N. Y.
For page see List of Advertisers
Phillip F. Kessler, 55 and 57 W. 26th St.
New York.
For page see List of Advertisers
A. Moltz, 55-57 W. 26th St., New York.
For page see List of Advertisers.
Millang Bros., 41 W. 28th St., New York.
For page see List of Advertisers.

Philadelphia

W. E. McKissock, 1619-1621 Ranstead St.,
Philadelphia, Pa.
For page see List of Advertisers.
Leo Niessen Co., 1209 Arch St., Philadel-
phia, Pa.
For page see List of Advertisers.
The S. S. Pennock-Meehan Co., 1608-18
Ludlow St., Philadelphia, Pa.
For page see List of Advertisers.
Edward Reid, 1526 Ranstead St., Phila-
delphia, Pa.
For page see List of Advertisers.

Pittsburg

J. B. Murdoch & Co., 714 Penn Ave., Pitts-
burgh, Pa.
For page see List of Advertisers.

St. Louis

H. G. Berning, 1402 Pine St., St. Louis, Mo
For page see List of Advertisers

WHOLESALE PLANTSMAN

Samuel A. Woodrow, 53 W. 30th St.,
New York.
For page see List of Advertisers.

WILD SMILAX

E. A. Beaven, Evergreen, Ala.
Southern Wild Smilax: Log Mosses.
For page see List of Advertisers.

New Offers in This Issue.

AMERICAN BEAUTIES: ASPARA-
GUS PLUMOSUS AND
SPRENGERI:
VINCAS.

Eric Floral Co., Erie, Pa.
For page see List of Advertisers.

CATTELEYAS, DENDROBIUMS,
JUST RECEIVED.

Lager & Hurrell, Summit, N. J.
For page see List of Advertisers.

CLOSING PLANT AUCTION SALE.

Wm. Elliott & Sons, 42 Vesey St.,
New York.
For page see List of Advertisers.

**EVERYTHING FOR GREENHOUSE
BUILDING.**

King Construction Co., N. Tonawanda,
New York.
For page see List of Advertisers

FIELD-GROWN CARNATIONS.

Chicago Carnation Co., Joliet, Ill.
For page see List of Advertisers.

**FLORISTS' WIRE DESIGNS AND
SUPPLIES.**

Weigel & Uffalussy, 136-138 W. 28th St.,
New York.
For page see List of Advertisers.

ORCHIDS: SPECIAL ARRIVAL.

Joseph A. Manda, 131 Valley Road,
West Orange, N. J.
For page see List of Advertisers.

PLANT TUBS.

Don A. Dreeg, 714 Chestnut St., Phila-
delphia.
For page see List of Advertisers.

ROSE PLANTS READY.

Leo Niessen Co., 1209 Arch St., Phila., Pa.
For page see List of Advertisers.

SEEDS. DOUBLE ENGLISH DAISY.

H. F. Mitchell Co., Philadelphia.
For page see List of Advertisers.

WANTED: GARDENIAS.

Knight & Struck, 1 Madison Ave.,
New York.
For page see List of Advertisers.

SITUATIONS WANTED**GOOD MEN**

When you need good men,
skilled or unskilled, Write:

**THOS. H.
BAMBRICK**

34 South 7th Street Philadelphia

Help of all kinds, including that for
Florists, Nurserymen, Seedsmen and the
Horticultural trade generally.

SITUATION WANTED—By young
Scotchman, age 23 years, as foreman in
commercial or private place. Well up in
the growing of carnations, chrysanthem-
ums, etc.; also landscape work. Apply
W. C. care HORTICULTURE.

HELP WANTED**WANTED**

A sober and reliable young married man
capable of taking charge of retail and
packing department and a good designer.
A permanent position for one who will
take care of 11, 40,000 ft. of glass.
Wages \$15.00 per week. No book work.

J. F. AMMANN, Edwardsville, Ill.

FOR SALE

FOR SALE—Special—Glass for sale be-
low cost. 16 x 24 double thick American
A. & B. qualities, below cost, for imme-
diate acceptance. Never such an opportunity
offered before. Write Parselsky Bros., 59
Montrose Ave., Brooklyn, N. Y.

FOR SALE 27,000 feet of glass; filled
with first-class stock; located in one of
Chicago's suburbs; low price. Address
Florist, 1016 N. Clark St., Chicago.

**GREENHOUSES BUILDING OR
CONTEMPLATED.**

Oakland, Calif.—I. M. Holland, one
house.

Springfield, O.—C. M. Howell, house
20x50.

Media, Pa.—Walter S. Rittle, range
of houses.

No. Adams, Mass.—Normal school,
one house.

Princeton, Ill.—Trimble Greenhouse
Co., one house.

St. Louis, Mo.—Eggeling Floral Co.,
range of houses.

Hoopston, Ill.—Peterson & Law-
ren, house 75x250.

Lexington, Ky.—Honaker The Flor-
ist, rose house, 30x150

Gardenville, Md.—J. O. Wilhelm, as-
paragus house 200 ft. long.

Richmond, Va.—W. H. Gordon, one
house, boiler house and potting shed.

Newport, R. I.—John R. Drexel, four
houses; Mrs. F. C. French, range of
houses.

Philip Krebs, formerly of Maspeth,
Long Isl., N. Y., is about to begin the
erection of a range of carnation houses
at Orangeburg, N. Y.

"The Moorings," Marion, Mass.—
Fruit house, vegetable house, plant
house, propagating house, as part of a
larger range to be erected later.

The Ulrich property at Woodside,
N. Y., has been sold to settle the estate.
The greenhouses are to be torn down,
and Mr. Ulrich will probably remove
to Spring Valley, N. Y., and erect a
new range at that place.

List of Advertisers

	Page		Page
Advance, The Co.	807	Lager & Harrell	791
Allen J. K.	748	Langjahr, Alfred H.	798
Altmo Culture Co.	793	Leuthy A. & Co.	78
American Nursery	780	Lord & Burnham Co.	808
American Nursery Co.	780	Lutton W. H.	807
Ammann J. F.	814	Manda Jos. A.	791
Aschmann G.	780	MacMullen E. A.	795
Atlanta Floral Co.	794	McCarthy N. F. & Co.	799
Bambrick Thos. H.	804	McConnell Alex.	794
Barrows H. H. & Son	791	McKellar Charles W.	796
Bayersdorfer H. & Co.	797	McKissick, W. E.	796
Bay State Nurseries	780	McManus Jas.	798
Beaven E. A.	796	Michell H. F. Co.	793-805
Berning H. G.	799	Michigan Cut Flower Exchange	799
Boddington A. T.	793	Millang Bros.	799
Boston Florist Letter Co.	799	Mitting, A.	78
Boston Plate and Window Glass Co.	806	Moltz, A.	799
Bosch, Felix.	779	Mooneyer J. C.	806
Bostrom-Brady Mfg. Co.	797	Moore, Heutz & Nash	798
Braslan Seed Growers Co.	793	Murdoch J. B. & Co.	796
Breck Joseph & Sons	793	Murray Samuel	794
Breitnueyer's J. Sons	794	Niessen Leo. Co.	796
Bridgeman's Seed Warehouse	793	Ordonez Bros.	791
Budlong J. A.	796	Ouwerkerk P.	781
Burpee W. A. & Co.	793	Palethorpe P. R. Co.	805
Carrillo & Baldwin	791	Park Floral Co.	794
Cassidy I.	807	Payne John A.	805
Castle Co.	806	Pennock-Meehan Co.	796
Champion J. N. & Co.	794	Perkins St. Nurseries	778
Chicago Caratation Co.	779	Pierce F. O. Co.	807
Clarke's David & Sons	794	Pierson, A. N.	778
Clary's Horticultural Co.	799	Pierson F. R. Co.	779
Cohanzie Carnation Greenhouses	778	Pierson U Bar Co.	803
Cowee W. J.	795	Peehlmann Bros. Co.	780
Craig, Robt. Co.	780	Pulverized Manure	808-5
Dingee & Conard Co.	780	Quaker City Machine Co.	807
Doane Geo. B. & Son	807	Quinlan P. R.	792
Dorner F. Sons & Co.	778	Raynor John I.	798
Dreer H. A.	806-807	Reed & Keller	798
Dnnlop John H.	784	Reid Edw.	786
Dysart R. J.	796	Reinberg Peter.	796
Eastern Nurseries	780	Rice Bros.	796
Edgar, W. W. Co.	779	Rickards Bros.	793
Edwards Folding Box Co.	796	Robinson H. M. & Co.	799
Elliott Wm & Sons	792-805	Rock Wm. L. Flo. Co.	794
Esler J. G.	807	Roehrs Julius Co.	791
Erie Floral Co.	780	Roher Albert.	779
Ernest W. H.	805	Roland, Thomas	778
Eskeisen Frank K.	750	Rolker August & Sons	778-805
Eyres	794	Rose Hill Nurseries	778
Farouhar R. & J. & Co.	792	Rupp J. E.	793
Fenrich J. S.	798	Sander & Son	791
Fiske, H. E. Seed Co.	793	Schlurff Vern L.	778
Foley Mfg. Co.	807	Schulz Jacob.	794
Ford Bros.	798	Scott, John	791
Froment H. E.	798	Sharp, Partridge & Co.	806
Galvin Thos. F.	795	Sheridan W. F.	798
Grey T. J. Co.	793	Siggers & Siggers	806
Gude Bros. Co.	794	Situations & Wants	804
Guttman Alex. J.	798	Skidelsky S. S.	78
Haereas A.	778	Smyth Wm. J.	794
Hall Asso.	807	Standard Plate Glass Co.	806
Haines, J. E.	779	Stearns A. T. Lumber Co.	807
Hart, Geo. B.	795	Stump & Walter Co.	778-805
Hartmann Hjalmar & Co.	793	Thorbara J. M. & Co.	793
Hauswirth M. C. & J. E.	794	Totty Chas. H.	792
Heacock Joseph.	780	Tower Hotel.	796
Herbert David & Son	792	Traendly & Schenck	798
Hews A. H. & Co.	805	Valentine, J. A.	794
Hicks Frank S. & Co.	799	Velthuys K.	779
Hilfinger Bros.	805	Vick's Jas. Sons	793
Hill, The E. G. Co.	780	Vincent R. Jr. & Sons	778-792
Hitchcock E. H.	795	Waterer John & Sons	780
Hoerig M. J.	795	Weathered Co.	808
Hoffman	795	Weber F. C.	794
Horan E. C.	798	Welch Bros.	796
Houghton & Clark	795	Weigel & Ujalussy	795
Hunt E. H.	805	Wilson	794
Illinois Heating & Mfg. Co.	795	Winterson, E. F. Co.	796
Jacobs S. & Sons	806	Withold Geo. Co.	794
Kastlag W. F.	790	Woodman F. & Co.	779
Kessler, P. F.	798	Woodrow, Sam'l A.	779
King Cons. Co.	807	Yokohama Nursery	779
Knight & Struck	779	Yong & Nugent	794
Kroeschell Bros.	806	Zangen O. V.	793
Kuebler Wm H.	790	Zinn Julius A.	795
		Zovianek A. C.	793

John A. Payne

Greenhouse Designer and Builder
260-274 Culver Ave., Jersey City, N. J.

The PAYNE "Grip - tight Fitting" Pipe Tie

for purlins and columns, is the strongest and most secure fitting yet produced for this purpose, because it is held fast by two bolts where the greatest grip is required. They cannot break because the bolts are close to edge of pipe.

Iron and Wood Frame Greenhouses of every type. Material only or erected.

Let us estimate on your requirements.

Everything for the Greenhouse

The Best Bug Killer and Bloom Saver

For PROOF Write to

P. R. Palethorpe Co.
OWENSBORO, KY.

- LIST OF PATENTS.**
- 889,285 Seed Planter. Paul E. Williams, Paris, Texas.
 - 889,290 Windmill. Albert J. Anderson, Batavia, Ill., assignor to U. S. Wind Engine & Pump Company, Batavia, Ill.
 - 889,329 Attachment for Seed-Planters. Charley O. Pallas, Barnesville, Minn.
 - 889,249 Greenhouse Bench. John Wilcox, Short Hills, N. J., assignor by direct and mesne assignments, to Wilson - Hoyt Company, Short Hills, a Corporation of New Jersey.
 - 889,363 Mower. Frederick W. Gaefke, Ottawa, Ill.
 - 889,413 Windmill. Holland G. Tucker, Hierford, Tex., assignor to William J. Luna, Hereford, Tex.

STERILIZED

Sheep Manure to help out backward vegetation, 100 lbs. \$1.50.

W.M. ELLIOTT & SONS
42 Vesey Street, New York

DON'T EXPERIMENT
USE
To-BAK-INE

and your stock will be free from insects, clean, and the blooms will not be discolored.

Send for full information of

H. E. FISKE SEED CO.
13 Faneuil Hall Sq., Boston, Mass.

STUMPP & WALTER CO.,
50 Barclay St., New York.

HENRY F. MICHELL & CO.,
1018 Market St., Philadelphia.

E. H. HUNT, Gen'l Agent,
76-78 Wabash Ave., Chicago.

ESTAB. 1765
A. H. HEWES & CO.
No. CAMBRIDGE MASS.
L. I. CITY N. Y.
CATALOGUE FREE

STANDARD FLOWER POTS

Packed in small crates, easy to handle.

Price per crate	Price per crate	
1500 2 1/2 in. pots in crate \$4.88	120 7 in. pots in crate \$4.20	
1500 2 1/4 " " " 5.25	60 8 " " " 3.00	
1500 2 1/8 " " " 6.00	HAND MADE	
1000 3 " " " 5.00	48 9 in. pots in crate \$3.60	
800 3 1/2 " " " 5.80	48 10 " " " 4.80	
500 4 " " " 4.50	24 11 " " " 3.60	
320 5 " " " 4.51	12 12 " " " 4.80	
144 6 " " " 3.16	6 16 " " " 4.50	

Seed pans, same price as pots. Send for price list of Cylinders for Cut flowers, Hanging Baskets, Lawn Vases, etc. Ten percent. off for cash with order. Address **Hilfinger Bros., Pottery, Fort Edward, N. Y.** August Rolker & Sons, Agts., 31 Barclay St., N. Y. City.

Standard Flower POTS

If your greenhouses are within 500 miles of the Capital, write us, we can save you money

W. H. ERNEST
28th and M Street WASHINGTON D. C.

Wizard BRAND MANURES

Cattle Manure In Bags

Shredded or Pulverized

Best and safest manure for florists and greenhouse use, absolutely pure, no waste, no danger. Write for circulars and prices.

The Pulverized Manure Co.,
31 Union Stock Yards, Chicago

Is Your Name In The Above List? If Not, Why Not?

Expressions from Men Who Know

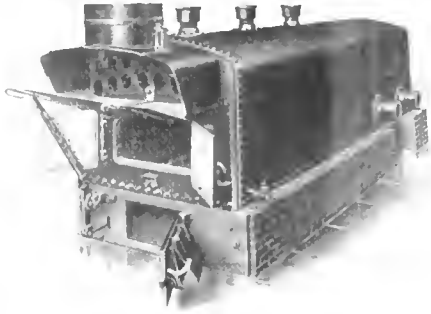

Mr. J. G. Frisz, of Vincennes, Ind., writes as follows:
 "Your No. 14 Boiler is carrying 25,000 square feet of glass and I can keep it at 100° in the coldest weather without any trouble. I have three other types of boilers also heating a range of 25,000 square feet of glass, but the **No. 13 Kroeschell boiler only takes half the coal and half the work**, to get the same results."

P. S.—Mr. J. G. Frisz, of Vincennes, Indiana, has the largest range of glass in Indiana devoted to vegetable forcing."

Damm Bros., Chicago, Ill., write:
 "In 1884 we bought one of your No. 12 boilers to take the place of four smaller boilers of another make. Your boiler has done the entire work to the highest satisfaction, **saving labor** and about **one-third of the fuel** we used to burn before. We had that boiler up to 1906, that is 12 years, having no repairs on it whatever, except one set of flues we put in in 1900. Last fall we installed one of your No. 14 boilers, having enlarged our plant. It takes care of 35,000 square feet of glass very easy. When firing we keep the ash door open only about one inch. We think your No. 14 boiler could carry 40,000 square feet of glass."

Mr. Nic Zweifel, North Milwaukee, Wis., writes:
 "I have a range of 200 foot houses with a total of 27,000 square feet of glass. **I can get all the pipes warm in 30 minutes** with one of your No. 14 Greenhouse Boilers and it is very easy firing. Can fire just as easy with screenings as with lump coal."

KROESCHELL BROS. CO., 35 ERIE ST., CHICAGO

Don't Build

without first investigating the best device ever invented for *Heating Economy.*

Don't Repair

until you have got some information as to how we can help you by installing the

ELECTRIC CIRCULATOR

State your proposition and we will reply promptly. It will cost you nothing but a two cent stamp.

THE CASTLE COMPANY, HEATING ENGINEERS
170 Summer Street, - BOSTON, MASS.

OTHER BUSINESS MEN MAY "EASE UP"

during the heated term but the florist does not. His greenhouses must be repaired and it takes **Glass and Pipes and Lumber** to do it.

Now is the time to advertise if you want his trade

His **Boiler** must be made right now; if you sell heating apparatus get him to buy a new one. Perhaps the time has come for a new watering system. You can reach him most effectually through an advertisement in these pages, **JUST NOW.**



DREYER'S Florist Specialties.
 New Brand—New Style—
Hose "REVERTON"
 Furnished in lengths up to 500 ft. without seam or joint.
 The HOSE for the FLORIST
 3-inch, per ft., 1 1/2 c.
 Keel 1 1/2 ft., 14 1/2 c.
 2 Reels, 100 ft., 14 c.
 1 1/2-inch, 1 1/2 c.
 Keels, 50 ft., 12 1/2 c.
 Compl'ings furnished!
HENRY A. DREYER,
 714 Chestnut St.,
 PHILADELPHIA, PA.

BOSTON PLATE & WINDOW GLASS CO.
GREENHOUSE GLASS
 German and American
 261 to 287 A St., Boston 20-22 Canal St.

STANDARD PLATE GLASS CO.

Manufacturers—Importers—Jobbers

NOW IS THE TIME TO BUY

FRENCH OR AMERICAN GREENHOUSE GLASS

LOWEST PRICES ON REQUEST

26-30 Sudbury St. BOSTON, MASS. 61-63 Portland St.

GLASS Always Write Us Before Buying
SHARP, PARTRIDGE & CO.
 22nd and Lumber Streets, CHICAGO
WE HAVE SOME SNAPS

S. JACOBS & SONS

Manufacturers of GULF CYPRESS
GREENHOUSE MATERIAL
 HOT-BED-SASH & FRAMES

Jobbers in **Boilers-Pipe-Fittings** and
GLASS on which we can quote attractive prices. Disc on large quantities.
 We furnish every thing for Greenhouse Building
1365-1379 Flushing Avenue
BROOKLYN, - NEW YORK

GREENHOUSE CONSTRUCTION LUMBER

John C. Moninger Co.
117 E. Blackhawk St., CHICAGO

PATENTS

Trademarks and Copyrights

Send your business direct to Washington. Saves time and insures better service. Personal attention guaranteed. Twenty-five years' active service. SPECIALTY: "Working on the Failure of Others."

SIGGERS & SIGGERS

PATENT LAWYERS
 Box 9, National Union Building
 Washington, D. C.

In ordering goods please add "I saw it in HORTICULTURE."

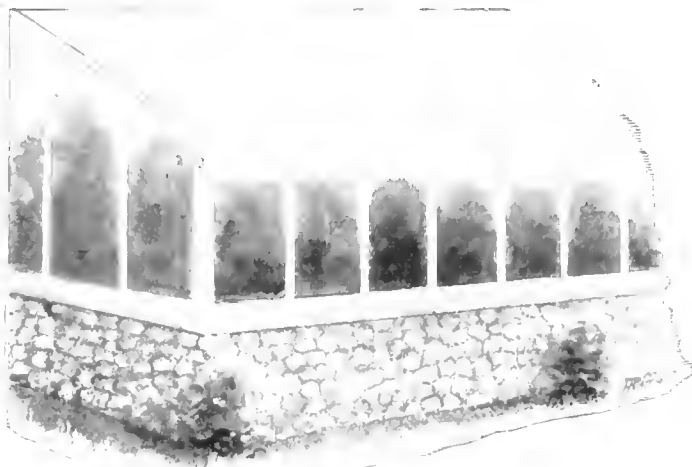

PATENT APPLIED FOR

Why My New Curved Iceless Eave is Far Superior to Anything on the Market Today

- 1st. No sash bars incased in iron, thereby eliminating all danger of bars decaying.
- 2nd. Can be used in conjunction with iron frame construction, thereby doing away with that very objectionable feature, "columns."
- 3rd. Roof bars with drip grooves, which act as conductors to carry away the condensation: **Result**, the driest roof ever used for greenhouse purposes.
- 4th. **THE MOST IMPORTANT OF THEM ALL.** The very small increase in cost over the ordinary style of construction which makes it possible to be used for commercial as well as private purposes.

William H. Lutton, Horticultural Architect and Builder
West Side Ave Station (C.R.R. of N.J.) Jersey City, N.J.

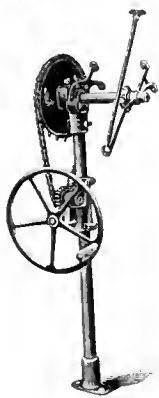

The Advance Ventilating Apparatus

"Your machine is the best we have ever used" is what an Ohio florist writes us in remitting for his machine. It is not good only in one part but it is the best in all parts—the results of experience, of careful study, of mechanical construction, best material and backed by moderate prices that makes our line so popular. Give us a trial.

The Advance Co.
RICHMOND, IND.

THE FOLEY MFG. CO.

CHICAGO

Completely equipped with up-to-date machinery for the making of material for

GREENHOUSE CONSTRUCTION

From a Full Supply of Thoroughly Seasoned Lumber

Send your sketches to our draughtsmen for completion and suggestion. Permit us to figure your proposed work, large or small.

We guarantee our prices will save you money

FOLEY VENTILATING APPARATUS IS THE BEST

s Simple in Erecting. Is Easiest of Operation. It Will Last a Lifetime. Its Price is the Lowest. Will Ventilate Any Size House. Prices and Circulars on Application.

Our 1908 Catalogue Greenhouse Material Sent Postpaid on Request.

THE FOLEY MFG. CO., WESTERN AVENUE 25th and 26th STS., CHICAGO

IRON PIPE

SECOND HAND

WROUGHT IRON PIPE, for Steam, Water, Gas or Oil, Fences or Posts. All Sizes. Price Low.

GEO. B. DOANE & SON
18 Midway Street, BOSTON
Telephone, Main 4419



Evans 20th Century Arm

Will not twist your shafting pipe. Give it a trial and you will use no other. Three times the power of elbow arms.

Write for Catalogue
QUAKER CITY MACHINE CO.
Richmond, Ind.

Holds Glass Firmly
See the Point of
PEERLESS

FULL SIZE
NO. 2

Glazing Points are the best. No rights or lefts. Box of 1,000 points 75 cts. postpaid.
HENRY A. BREER,
114 Chestnut St., Philadelphia, Pa.

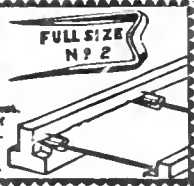

CYPRESS SASH BARS
82 feet or longer

HOT BED SASH
PECKY CYPRESS BENCH LUMBER

GREENHOUSES

ERECTED AND EQUIPPED COMPLETE IF DESIRED

Write for Circular "D" and Prices

The A. T. STEARNS LUMBER CO.
NEPONSET, BOSTON, MASS.

In ordering goods please add "I saw it in HORTICULTURE."

I. CASSIDY
Designer and Builder of
Iron and Wood Greenhouses

Factory: Summer Ave and Erie R. R.
Newark, N. J.

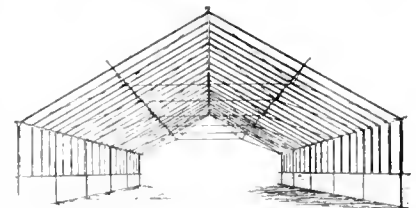

King Greenhouses

Tru sed Roofs- King Gutter- and Eaves, Ventilating Machinery Trussed Iron-frame Houses, Tilt Benches and Pipe Hangers. Everything for greenhouse building.

Write for Information and Prices.

King Construction Company
North Tonawanda, N. Y.

MASTICA

FOR Greenhouse Glazing



USE IT NOW.
F. O. PIERCE CO.
12 W. Broadway and
227 Greenwich St.
NEW YORK

The FLORISTS' HALL ASSOCIATION OF AMERICA, insurer of 29,000,000 sq. ft. of glass. For particulars address John C. Esler, Sec'y, Saddle River, N. J.

THE HOUSE OF GREATEST SUNLIGHT

LIGHTEST INTERIOR in the WORLD
THIS HOUSE IS 35 1/2 FEET WIDE
Note: No Columns

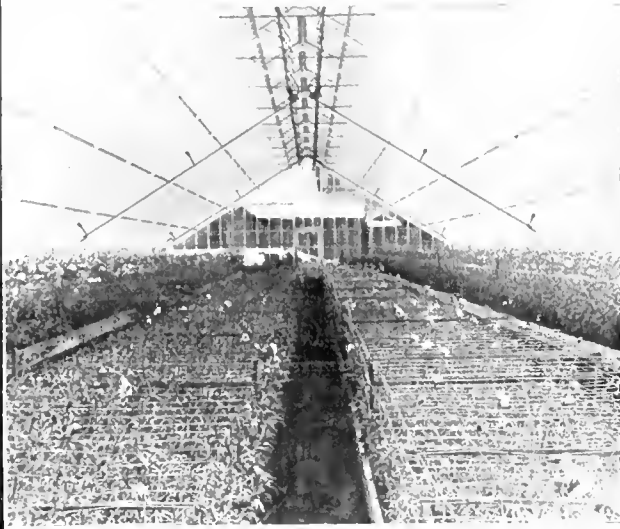

Erected for J. J. BROZAT, Bloomfield, N. J.

BY THE

WEATHERED COMPANY

IRON FRAME, SEMI-IRON FRAME, OR ALL SASH
BAR HOUSES, ERECTED OR MATERIAL ONLY

... SEND FOR CATALOGUE ...

P. O. Address Box 789 NEW YORK CITY, N. Y.

Close Vent' Work

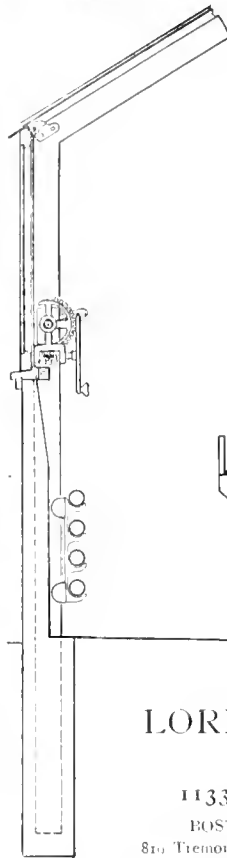

YOU see how this ventilating machine of ours squeezes itself up into such a compact piece of mechanism that it doesn't extend any farther in the walks than the heating pipes. It's easy to erect and it is mighty powerful. Told all about in the new Ventilating Catalog. Send for it.

We make every part of a greenhouse but the glass. We sell any part.

LORD & BURNHAM CO.

MAIN SALES OFFICE :

1133 BROADWAY, NEW YORK

BOSTON :
810 Tremont Building

PHILADELPHIA :
1215 Filbert St.

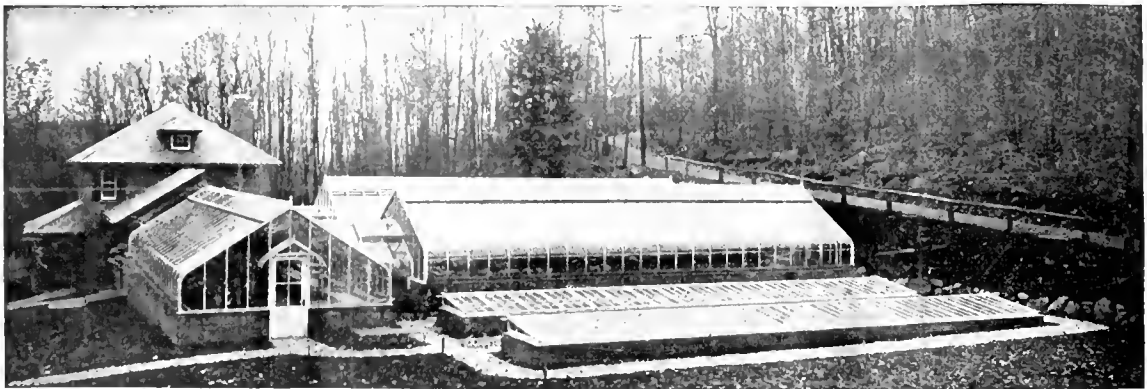

THEY ADMIT MORE LIGHT

because they have wider glass, fewer and smaller framing members, and no gutter at eave. Not only the lightest, simplest, strongest, but the most enduring houses; for attractiveness and productiveness and low cost of maintenance, unequalled.

Send for catalog.

The ideal construction for private estates, parks, public institutions and florists' storerooms

U-BAR GREENHOUSES

PIERSON

DESIGNERS AND BUILDERS



U-BAR CO.

1 MADISON AVE. NEW YORK

HORTICULTURE

Vol. VII.

JUNE 20, 1908

No. 25

LIBRARY
NEW
BOTANICAL
GARDEN



CHARLES J. BROWN
President elect, American Association of Nurserymen

*Devoted to the
FLORIST, PLANTSMAN,
LANDSCAPE GARDENER
and
Kindred Interests*

*Published
EVERY SATURDAY
At 11 Hamilton Place,
BOSTON, MASS.
Subscription, \$1.00*

GERANIUMS

A **C**ORDIAL INVITATION IS extended to all interested in Geraniums, to visit us in June, to inspect our new stock houses containing over 60,000 plants, and especially our new show houses; in them there are over 300 varieties in full bloom, a splendid opportunity to compare the newer introduction with the Standards, and to select stock for next season. We will make very liberal special prices on all orders booked during June for December delivery. We are at Cowenton on the B. & O. R. R., and at Chase on the Pennsylvania. We meet all trains.

READY FOR SHIPMENT FROM 2-in. POTS

Standard Sorts at \$2.00 per 100 and up. We will send 1000, fifty each of twenty varieties, our selection, for \$18.50, single or double, all good sorts, a splendid collection to stock up on.

Newer Varieties selected from the finest introductions of 1905-6 at \$6.00 to \$8.00 per 100. Novelties, one each of 50 varieties for \$5.00. 1907 introduction from Bruants, Lemoines, Rozain Boucharlat, Cannells, etc.

SMILAX, strong plants, \$2.00 per 100.
 COLEI S, Golden Bedder and Verschaffeltii, 2 in., \$2.00 per 100.
 3 in., 3.00 per 100

BEGONIA, Vernon and Gracilis, 2 in., \$2.00 per 100.
 HARDY CHRYSANTHEMUMS, \$2.00 per 100. 500 in 20 varieties, our selection for \$9.00. 1000 in 20 varieties our selection for \$17.50, strong plants from 2 in. pots.

R. VINCENT JR. & SONS COMPANY, White Marsh, Md.

COLD STORAGE LILIES

COLD STORAGE LILIES, means that you can have Lilies all the year round. What are more useful, or give more character to the funeral piece than the Lily. We have, and can deliver at any time cold storage Lilies—2nd can refer you to hundreds that are growing them, why not you?

LILIUM LONGIFLORUM GIGANTEUM is the only longiflorum that gives satisfaction from cold storage—we offer them as follows:—LILIUM LONGIFLORUM GIGANTEUM (repacked 6 to 8 inch bulbs 400 in a case, \$8.50 per 100, \$75.00 per 1000, case of 400 for \$30.00. 7 to 9 inch bulbs, 300 in a case \$9.00 per 100, \$85.00 per 1000, \$25.50 per case of 300. 9 to 10 inch bulbs, 200 in a case, \$14.00 per 100, \$130.00 per 1000, \$26.00 per case of 200.

ARTHUR T. BODDINGTON, Seedsman, 342 WEST 14TH STREET, NEW YORK CITY

TUBEROSES

EXCELSIOR DWARF PEARL 3 x 4 \$.60 per 100, \$5.00 per 1000
 4 x 6— 1.00 per 100, 8.00 per 1000
STUMPP & WALTER CO., 50 Barclay Street, NEW YORK

A HALF MILLION CALLA BULBS FOR SALE

CALLA ETHIOPICA BULBS, 7 to 8 inch circumference, \$65.00 per 1000
 " " " " 5 to 7 " " 49.00 " "
 " " " " 3 to 5 " " 25.00 " "
 250 at : : Rates, Freight Prepaid when Cash is sent with Order. Orders booked now for July shipments.

A. MITTING, 17 to 23 Kennan St., Santa Cruz, Cal.

AZALEAS

for fall delivery, the best PALMS for spring or fall delivery, furnished by that are grown, also AUGUST HAERENS, Somergem, Belgium; orders booked, now, . . .
AUGUST ROLKER & SONS, 31 Barclay Street, or P. O. Box 752, New York

Established 40 Years
Rose Hill Nurseries
 New and Rare Plants
NEW ROCHELLE, N. Y.

New York Office, Siebrecht Building, 425 Fifth Avenue

DAHLIAS. Now is the time to place your order for bulbs which will insure you getting named varieties in any quantity; prompt delivery.

DAVID HERBERT & SON,
 Successors to L. K. Peacock, Inc.
ATCO, N. J.

COLEUS

Verschaffeltii, Golden Queen, Fire Brand, Lord Palmerston, Queen Victoria, Beckwith's Gem. Prices of Rooted Cuttings by express, 60c, per 100; \$5 per 1000. Less than 250 of a variety will be charged at the 100 rate.

Golden Bedder, Hero, Tessey, Pearl of Orange. 75c. per 100; \$6 per 1000. Less than 250 of a variety will be charged at the 100 rate.

Fancy Varieties. A very fine assortment of twelve kinds not listed above, 75c. per 100; \$6 per 1000. 250, 10 assortment, our selection, at the 1000 rate.

MISCELLANEOUS PLANTS

AGERATUM, Stella Gurney, Princess Pauline.
 SALVIA Splendens, Bonfire. HELIOTROPE.
 Rooted cuttings, 75c. per 100; \$6 per 1000.

CARNATIONS

Rooted Cuttings	100	1000
Winsor.....	\$6.00	\$50.00
White Perfection.....	2.50	20.00
Rose Pink Enchantress.....	3.50	30.00
Enchantress.....	2.50	20.00
Queen Louise.....	2.50	20.00

From 2 1/4 inch pots, add \$1.00 per 100.

ASPARAGUS PLUMOSUS NANUS SEEDLINGS

From flats, \$13.00 per 1000.

CHRYSANTHEMUMS

Standard varieties, ready for shipment. Rooted cuttings, \$2 per 100; \$15 per 1000. Send for list.

A. N. PIERSON, CROMWELL, CONN.

Surplus Plants

	Per 100
300 Salvia Splendens, 4 in. - - -	\$5.00
1500 " " 3 in. - - -	3.00
150 Ageratum, 2 1/2 in. - - -	1.50
500 Alyssum, Carpet of Snow, 2 1/2 in. -	2.50
750 Alternanthera, red, 2 in. - - -	2.00
650 " yellow, 2 in. - - -	2.00
100 Cuphea, 3 in. - - - - -	2.00
200 Verbenas, 2 1/2 in. - - - - -	1.50
300 Canna (Chas. Henderson) - - -	5.00
300 " (Florence Vaughan) - - -	5.00
1000 Geraniums (mostly S. A. Nutt) 3 in. -	3.50
1000 " " " " 4 in. - - -	7.00
1500 Madam Salleroi, 3 in. - - -	3.00

VERN L. SCHLURAFF
ERIE, PA.

Bedding Plants

All Kinds, Stocky, Good Size, Low Price. Can supply the Trade in quantity.

Just Received

A big shipment of ARAUCARIAS, PALMS, etc. Orders taken now for import for fall delivery.

A LEUTHY & CO.

PERKINS ST. NURSERIES
ROSLINDALE, MASS.

Gloire de Lorraine Begonia

2 1/4 inch pots, \$15.00 per 100
 \$140.00 per 1000

Thomas Roland,
Nahant, Mass.

Begonia Gloire de Lorraine

Strong 2 1/2 in. pot plants, leaf cuttings, \$15 per 100, \$140 per 1000. Early June delivery or NOW if wanted.

S. S. SKIDELSKY, 1741 No. 18th St. PHILADELPHIA

In ordering goods please add "I saw it in HORTICULTURE."

CANNAS

STARTED PLANTS in 3 1/2 and 4-in. POTS READY FOR IMMEDIATE PLANTING

Mme. Nardy, Mlle. Berat, Robert Christie, Golden King, Pennsylvania, L. Patry, Florence Vaughan, Pandora, Austria, Rohallion, Pierson's Premier, Queen Charlotte, Frederick Benary, etc.

EXTRA STRONG PLANTS, \$6.00 PER 100

VINCAS AND ENGLISH IVIES

Extra fine plants in 1/2 and 4 inch pots, for vases, tubs, etc. \$3.00 per 100; extra size, \$10.00 per 100.

HYDRANGEA OTAKSA

LARGE PLANTS IN TUBS AND HALF-BARRELS FOR JULY AND AUGUST FLOWERING
We make a specialty of these, and have a magnificent lot of large plants, which we can supply in any quantity—from single plants up to carload lots. Large plants in tubs, \$5.00 and \$7.00 each. Extra large plants in half-barrels, \$5.00 and \$7.50 each.

- NASTURTIUMS.** Bushy plants, 3 inch pots, \$6.00 per 100.
- SALVIA, Bon Fire.** 2 1/2 inch pots, \$4.00 per 100.
- AGERATUM.** 2 1/2 inch pots, \$3.00 per 100.
- MOON FLOWERS.** 2 1/2 inch pots, \$7.50 per 100.
- COLETS, assorted.** 2 1/2 inch pots, \$3.00 per 100.
- ALYSSUM, Tom Thumb.** 2 - inch pots, \$1.00 per 100.
- CROTONS, for bedding.** Extra strong plants, 3 1/2 inch pots, \$25.00 per 100; 5 inch pots, \$50.00 per 100.
- ACALYPHA M SAICA.** Extra choice, for bedding 2 1/2 inch pots, \$5.00 per 100.
- PANDANUS VEITCHII.** 5 inch pots, \$9.00 per dozen; 6 inch pots, \$12.00 per dozen. Large plants, \$2.00 to \$4.50 each, according to size.
- FICUS ELASTICA.** 5 inch pots, \$4.00 per doz. 6 inch pots, \$6.00 per doz.

- DRACENA FRAGRANS.** Extra large plants, 6 inch pots, 3 feet high, \$12.00 per dozen.
- FERNS, assorted.** Extra heavy plants, 2 1/2 inch pots, \$3.00 per 100; 3 1/2 inch pots, extra heavy, \$10.00 per 100.
- NEPHROLEPIS PIERSONI ELEGANTISSIMA.** 2 1/2 inch pots, \$5.00 per 100; 3 1/2 inch pots, \$15.00 per 100, 6 inch pots, \$6.00 per dozen, 8 inch pots, \$12.00 per dozen.
- BOXWOOD, Pyramids.** Extra fine plants, \$2.00 and \$3.00 each.
- PANSIES, ENGLISH DAISIES, and FORGET-ME-NOTS.** \$3.00 per 100.
- CARNATIONS, Winsor and White Enchantress.** We can supply these in quantity, ready for immediate planting. Strong established plants from 2 1/2 inch pots, \$7.50 per 100; \$10.00 per 1000.

F. R. PIERSON CO., Tarrytown-on-Hudson, New York

Grab These BARGAINS

- Moonvines, best White, 4-in. 10 cents, 1 1/2-in. 5 cents.
- Scarlet Sage, Clara Bedman or Bonfire, 4-in. strong, \$5.00 per 100; \$15.00 per 1000.
- Clematis Jackmanni, late fall importation, 3 ft. high, nicely staked up, 35 to 40¢.
- Araucaria Excelsa Glauca, 6 to 7-in. pots, last spring (1907) importation, 3 tiers, 25 to 40 inches high, same in width, 6 year old, suitable for lawns and porches, \$1.75, \$2.00, \$2.50, \$3.00, \$4.00 each.
- Imported two weeks ago 5000 Araucaria Excelsa, 3 tiers, 6-8-10-in. high, 40 - 10-12-14-in., 500, 600, 750, \$1.00 each.
- Kentia Belmoreana, 4-in., 75¢, \$1.00, \$1.25, \$2.00, 5 1/2-in., 2 - 25 inches high, 500, 600; 4-in., 35¢. Forsteriana, large plants, \$2.50 each, 7-in., 40-50 inches high, \$3.00.
- Bay Trees, just arrived from Europe, Standard, 8-ft. high from top of tub, crown 30 inches in diameter, per pair, \$15.00.

Cash with order, please. All goods must travel at purchaser's risk

Godfrey Aschmann

Importer, Wholesale Grower and Shipper of Pot Plants

1012 West Ontario St. Philadelphia, Pa.

VEGETABLE PLANTS

CABBAGE Wakefield, Early Flat Dutch, Early Allhead, Early Drumhead and other early varieties. Surehead, Late Flat Dutch, Danish Round and Ballhead and other late varieties at 20¢ per 100, \$1.00 per 1,000, \$8.50 per 10,000.

TOMATO Stone, Favorite, Paragon, etc., at 20¢ per 100, \$1.00 per 1,000, \$8.50 per 10,000. Dwarf Stone and Champion, June Pink and Early Jewell at 40¢ per 100, \$2.00 per 1,000.

CELERY White Plume, Giant Pascal, Gol Heart and other varieties, 20¢ per 100, \$1.00 per 1,000, \$8.50 per 10,000.

BEEF Eclipse, Crosby and Egyptian, 25¢ per 100, \$1.25 per 1,000. Cash with order.

R. VINCENT JR. & SONS CO. WHITE MARSH, MD.

BAY STATE

The big sensation of all the recent Carnation Shows. A noble flower, white with carmine markings.

Now Booking Orders for Next January Delivery.

Rooted Cuttings, \$12.00 per 100, \$100.00 per 1000

ALBERT ROPER, Tewkesbury, Mass.

POT CHRYSANTHEMUMS

BEST VARIETIES FOR BUSH PLANTS IN POTS
Large Flowered, Pompon, Anemone Flowered and Single.

Good Assortment in Early Mid season and Late, 50¢ per doz., \$3.00 per 100.

PRIMULA OBCONICA and P. CHINENSIS Best Varieties

Ready July 15th. 1/2 in. pots, \$1.00 per 100, \$25.00 per 1000.

FERNS for DISHES

Assorted Varieties, from 2 in. pots, \$3.00 per 100, \$25.00 per 1000.

CASH WITH ORDER

FRANK OECHSLIN

2570-2606 W. Adams St., Chicago. Formerly Garfield Park Flower Co.

Look through the Buyers' Directory and Ready Reference Guide. You will find some good offers there also.

HYACINTHS, TULIPS, NARCISSI AND OTHER BULBS

ROMAN HYACINTHS and the true PAPER WHITE GRANDIFLORA

Ask for our Wholesale Trade List at Hillegom

K. VELTHUYS, Hillegom, Holland Rep. by FELIX 3033A, 260 Clarendon St., Boston.

CARNATIONS

F. DORNER & SONS CO. La Fayette, Ind.

BEST VARIETIES Field-grown

CARNATION PLANTS

CHICAGO CARNATION CO.

A. T. PYFER, MGR. JOLIET, ILL.

JOHN E. HAINES Bethlehem, Pa.

is the place to order rooted-cuttings of the following varieties for 1908.

John E. Haines, red	Per 100	Per 1000
Imperial variegated		
Pink Imperial, Pink	\$6.00	\$50.00
Enchantress, Light Pink		
Place your orders early for Jan. delivery.		

JAPANESE

THE YOKOHAMA NURSERY CO. LILIES PLANTS BAMBOO STAKES

31 BARCLAY STR. NEW YORK.

Prices Quoted in these Columns are for Dealers Only. When Writing to Advertisers Please Mention HORTICULTURE.

ROSES

100 of the best Hardy sorts.

HYBRID PERPETUALS
Finest English Grown Plants
Dozen, \$3.50; 100 \$25.00

EVERBLOOMING HYBRID TEAS
Bloom from Midsummer until frost.
Dozen \$5.00; 100, \$35.00

Hardy Climbing Roses
All the leading sorts.
Catalogue Free on Application.

R. & J. FARQUHAR & CO.
6 and 7 So Market Street,
Boston, Mass.

PALMS

Home Grown.

KENTIA BELMOREANA		COCOS WEDDELIANA	
	Each	Doz.	
6-in. pot, 6 to 7 leaves, 22 to 24 in.	\$1.00	\$12.00	2½ in. pot, 8 to 10 in. high 10 cents each
6-in. pot, 6 to 7 leaves, 24 to 26 in.	1.25	15.00	2½ in. pot, 10 to 12 in. high 15 cents each
6-in. pot, 6 to 7 leaves, 26 to 28 in.	1.50	18.00	
6-in. pot, 6 to 7 leaves, 30 to 36 in.	2.00	24.00	
7-in. pot, 6 to 7 leaves, 32 to 34 in. heavy	2.50	30.00	

A FULL LINE OF
KENTIAS
(All Sizes) READY IN JULY

JOSEPH HEACOCK COMPANY, Wyncote, Pa.

ROSES

Strong, Clean Stock. Grafted, Killarney, Richmond, Brides and Maids. \$12.00 per 100, \$110.00 per 1000. Own Roots, Brides, Maids, Gates, Ivory, Perle, Killarney and Richmond. \$6.00 per 100, \$55 per 1000. All from 3½ in. pots.
P. R. QUINLAN, Syracuse, N. Y.

CHRYSANTHEMUMS

In all standard varieties and colors now ready for planting from 2½ in. pots, \$3.00 per 100, \$20.00 per 1000.

CHARLES H. TOTTY, Madison, N. J.

Hardy Rhododendrons Azaleas Conifers, Clematis, H. P. Roses, Shrubs and Herbaceous Plants from our **HOLLAND NURSERIES**
Prices Moderate

P. OUWERKERK, 216 Jane St., Weehawken Heights, N. J.

FERNS

Assorted for JARDINIERS

Strong, healthy plants 2½ inch pots, \$3.00 per 100 \$25.00 per 1000; 500 at 1000 rate. 3 inch, \$6.00 per 100.

FRANK N. ESKESEN, MADISON, N. J.

In ordering goods please add "I saw it in HORTICULTURE."

ROBERT CRAIG CO.
ROSES, PALMS,
and Novelties in Decorative Plants
MARKET and 49th STREETS., PHILADELPHIA, PA.

JOHN WATERER & SON, Ltd.

American Nursery, Bagshot, England

Are Specialists in the
REALLY HARDY VARIETIES
of Rhododendron Hybrids and in Select Varieties of Hardy Border Plants.

FINEST LOT OF

HARDY HYBRID RHODODENDRONS

ALSO DWARF RHODODENDRONS
ANDROMEDA FLORIBUNDA

READY FOR IMMEDIATE SHIPMENT
ORDER TODAY

EASTERN NURSERIES, JAMAICA PLAIN, MASS.

HARDY NORTHERN GROWN NURSERY STOCK

At Reasonable Prices

FRUIT AND ORNAMENTAL TREES, SHRUBS, VINES, ROSES AND HERBACEOUS PERENNIALS IN GREAT VARIETY

Catalogue and Price List for the asking

BAY STATE NURSERIES, NORTH ABINGTON, MASS.

The Roses that Win

MRS. POTTER PALMER, CARDINAL American Beauty and Other Standard Varieties. Rooted from Our Famous Stock. Send for Prices.

POEHLMANN BROS. CO.
Morton Grove, Ill.

THE E. G. HILL CO.,

Richmond, Indiana

are now booking orders for splendid one year transplanted clumps of PEONIES the very finest varieties only, in perfect condition and at reasonable prices. We have not one poor variety in our entire collection but selected commercial sorts from the best of European and American varieties. Send for our price list.

ROSES

A SPECIALTY

The Dingee & Conard Co. West Grove PA.

AMERICAN NURSERY CO.,

COMBINING
FRED'K W. KELSEY, New York City
F. & F. NURSERIES, Springfield, N. J.
BLOODGOOD NURSERIES, Flushing, L. I.
N. J. & L. I. NURSERIES

We can supply you every need. Write for prices
Sales Department
150 BROADWAY, - NEW YORK

In writing to Advertisers kindly mention Horticulture

Notes from the Arnold Arboretum

As the last of the showy Ericaceous shrubs the Mountain Laurel is now in bloom and the large group on Hemlock Hill is a mass of pink flowers shown off to the greatest advantage by the dark background. The Mountain Laurel must certainly be considered as one of our most beautiful native shrubs and is as effective when massed in large groups as when planted singly as undergrowth on the borders of woods. A very fine variety is *Kalmia latifolia* var. *rubra* with deep pink flowers, while the white variety var. *alba* is perhaps less handsome than the common light pink form. Very peculiar is *K. latifolia* var. *monstruosa* which has the corolla divided into five narrow petals; the flower clusters have therefore a feathery appearance and the whole shrub looks very distinct from the ordinary Mountain Laurel. There is also a low small leaved variety called var. *myrtifolia* which is pretty as a small evergreen shrub but flowers not at all or very sparingly.

The brilliant *Rhododendron calendulaceum* is now passing and the less showy *R. arborescens* with pure white, very fragrant flowers is beginning to bloom and this species will be followed soon by the similar *R. viscosum*, the Swamp Honeysuckle.

Most of the Mock Oranges are now in bloom and particularly attractive are the many varieties of *Philadelphus Lemnii*. One of the best is *Avalanche* with gracefully spreading and arching branches covered their whole length with showy white flowers; it is one of the latest to bloom. *Gerbe de neige* is similar, but less graceful with larger flowers opening earlier. Handsome varieties with upright branches and single flowers are *Candelabra*, *Mont Blanc* and the somewhat later blooming *Parillon Blanc*, while *Bouquet Blanc* has large semidouble flowers. *Philadelphus microphyllus*, one of the parents of *P. Lemnii*, is an attractive little shrub with small myrtle-like foliage and small but deliciously fragrant flowers; it flowers later than the hybrids. Perhaps the most beautiful of the native species is *P. inodorus*, a compact shrub with lustrous foliage and large cup-shaped flowers solitary along the branches. *Philadelphus grandiflorus* which is often confounded with the preceding species, is a higher shrub with duller and larger foliage and flowers apparently less profusely.

The tree-like Japanese Lilac, *Syringa Japonica*, is now in full bloom and the two trees in the Arboretum are very conspicuous objects studded with their immense panicles of creamy white flowers. The similar but shrubby *S. amurensis* flowers somewhat earlier and is already fading.

The Yellow-wood, *Cladrastis tinctoria*, flowers this year profusely; with its large drooping panicles of white fragrant flowers it looks very charming and is particularly suited for planting as a solitary tree on the lawn; its chief drawback is that it does not flower every year.

A shrub of striking beauty is *Styrax japonica* when its spreading branches are loaded with the drooping white flowers; it is the hardiest of the *Styrax*, but requires here a sheltered position.

The handsomest of the Privets hardy in this vicinity is certainly *Ligustrum Itoya* with its gracefully arching branches covered their whole length with small droop-

ing clusters of white flowers. Also *L. acuminatum* (*L. ciliatum*, *L. medium*) is an attractive shrub when in bloom, though not as handsome as *L. Itoya*; it is of more upright habit with spreading branches bearing numerous small panicles of white flowers.

Among the later flowering Dogwoods *Cornus paniculata* (*C. caudidissima*) is one of the prettiest in bloom; it is a clean shrub of graceful habit and well adapted for borders of shrubberies. Another good Dogwood is *Cornus circinnata* which is now conspicuous with its numerous clusters of creamy white flowers.

Similar to the latter in habit is *Viburnum dentatum*, also a native shrub, but showier than this is the Japanese *V. dilatatum* which has much larger corymbs of white flowers followed in autumn by scarlet fruits. An interesting native species is *V. molle* which is now flowering for the first time in the Arboretum; it was first discovered more than 100 years ago by the elder Michaux, but was not found again until fifteen years ago and described then as a new species, *V. Demetrioides*, because the name *V. molle* had been in the meanwhile applied erroneously to another more common species; the true *V. molle* is still very rare in cultivation and as our plants are yet small, nothing definite can be said about its ornamental qualities.

Alfred Rehder.

Arnold Arboretum, Jamaica Plain, Mass.

The Hardy Rhododendron Question

I was delighted to read Mr. Koehler's interesting communication in HORTICULTURE on the above topic. I naturally differ from him in many of his remarks, but this I am sure is pardonable, as gardeners have oft found that their experience, scientific deductions, and "logical conclusions" have not always been unanimous. But then criticism is an essential feature in all things pertaining to the improvement and enlightenment of our profession, or in other words, it is the separator which takes the impossible from the possible and leaves us the workable idea.

When Mr. Koehler writes about Rhododendrons I receive what he says with interest and respect, because I feel certain that he has given the subject his careful attention for many years, and accordingly writes exactly what his experience has led him to believe as being correct. But when Mr. Koehler gets behind a rhododendron bush and fires a few illogical deductions at me I am tempted to again take up my pen in an effort to bring him back to the point. The point when examined closely has rather the appearance of two points—horn points of a dilemma.

Here then is the dilemma. A list of twelve Rhododendrons were given by me as being suitable for planting, under suitable conditions in New England. Those varieties, I may say, are all at the present time doing well at various establishments, to my knowledge, both in the vicinity of Boston and New York. Mr. Koehler on the other hand, with dogmatic assurance, and the true tontonic spirit of finality, classed my list as an undesirable mixture of facts and terminological inexactitudes. The question, therefore, devolves into one of individuals, and must be treated accordingly. I shall therefore endeavor to show Mr. Koehler a reason why

part of my list at least, should be included in his ironclad contingent.

Mr. Koehler remarks that it would not be unreasonable to demand as a test for hardiness, that a Rhododendron be able to satisfactorily withstand a winter without protection in the middle of a ten-acre field. I have thoroughly digested this interesting statement, and at once compare it with the following: "There is no ironclad list in the sense that that term can be applied to a common lilac." "Enough said." Surely a Rhododendron which planted in the middle of a ten-acre field "would survive a test of ten years, and at the end of that time still be shapely" must be classed as a most desirable variety. Would Mr. Koehler name, say, half a dozen varieties which would stand this treatment for ten years?

Regarding that part of Mr. Koehler's article where with a brilliant rhetorical flourish, he goes globe trotting, and takes in all the remote corners of the earth, these, I suppose, were what I might call his irrepressible digressions. Mr. Koehler's comparisons were ostensibly intended to illustrate his remarks, to enlighten readers as to his philosophy, to add something to the soundness and effectiveness of his logic. I think it did nothing of the kind. His remarks in this respect were perfectly obvious, and call for no reply from me, inasmuch as the remote parts of the earth are in the present instance quite outside my province, and have no part in the present discussion.

Mr. Koehler in the course of his remarks says, "Admittedly many Rhododendrons are hardy in localities in England, which are not hardy in New England." It appears to me that he has got a trifle mixed in this part of his article. I did not mention England, except as referring to that country as being the principal source from which we get our varieties, and I still think that the sentence quoted by Mr. Koehler is quite in order, and could not possibly be taken to mean anything other than what I intended it to mean.

It seems that Mr. Koehler is displeased with my using the very wide term New England States; why he should be, I am at a loss to understand. I should like to inform him that this term when used in a limited sense, is perfectly legitimate, and for this purpose I will give him a precedent where this very wide term has been used. In Bailey's *Cyclopedia of American Horticulture*, I find the following sentence in an article dealing with Rhododendrons, which was written by our esteemed and learned friend, Mr. Alfred Rehder: "Formerly it was considered impossible to grow the beautiful hardy hybrids in the New England States, but now it has been shown by such splendid collections as those of Mr. H. H. Hunnewell at Wellesley, Mass., that even in a trying climate they can be grown to perfection if the right situations are selected and the right way of cultivation is followed." Now, personally, I cannot see anything wrong in those words, contributed to a great horticultural work by one of the most brilliant writers in this country, and I still think that the term New England States, as I used it, is perfectly correct.

I feel sure Mr. Koehler will agree with me when I say that Mr. Rehder is one of the leading authorities on Rhododendrons in this country and that if he states that any particular variety is hardy in the New England States (or Boston and vicinity to suit Mr. Koehler's residential convenience) we should at once accept it as being the outcome of his careful observations. In Mr. Rehder's list of hardy varieties, suitable for planting in the vicinity of Boston, I find the following: Alex. Dancer, August Van Geert, Charles Bagley, Ever-

estium, and Hammbal. Mr. Koehler informs us that only two of those sorts are hardy. So much for those varieties. Now I will deal with The Queen. I can assure Mr. Koehler that this variety has been planted quite extensively throughout New England, and has invariably given satisfaction. I have before me a list of Rhododendrons (ironclads by the way) which was issued this year by a well-known firm in the vicinity of New York. This firm makes special reference to the fact that all of their stock have been grown for many years past in the open without the slightest protection whatever. Incidentally I may say that The Queen is included in their list of ironclads. How do you account for this, Mr. Koehler?

Mr. Koehler mentions R. S. Halford in his article. I am sorry I have not had the pleasure of seeing this variety in my travels; perhaps he meant Mrs. R. S. Halford. Regarding this variety and also Mrs. John Clutton, I can only emphasize what I have already stated, that they are both perfectly hardy if they are planted in the right situation, and a slight winter protection is given them. It appears, however, that one person at least, classed those two varieties as being ironclads, and recommended them as being most desirable varieties for Boston and vicinity. I refer to the late Mr. F. L. Harris, Wellesley, Mass. Mr. Harris so far back as 1897 recommended Mrs. John Clutton and Mrs. R. S. Halford as being absolutely hardy in the vicinity of Boston. (See *Gardening*, Vol. 5, No. 120, page 370.)

Much that Mr. Koehler has written in his concluding remarks I entirely agree with, and I make haste to say that I also have much to learn about Rhododendrons, and would be delighted to have the experience of other people on this subject provided the various points are met with solid facts and irrefragable logic.

When discussing as to whether a Rhododendron is hardy or not, one of the most important facts is often overlooked, namely, site. By far the largest number of Rhododendrons are planted on happy-go-lucky sites, that is, sites which are quite unsuited for giving good results. Hence arises the need of artificial protection for many varieties, which might safely be dispensed with in a less exposed location. Intelligent and systematic management may of course greatly lessen the disadvantages imposed by faulty environment, but say what we will, it is "site" first and last which is the most essential factor in successful Rhododendron culture.

What then is the crux of the whole question when we consider in this connection a few remaining points, such as the climatic conditions peculiar to the New England States, oscillating as it does between the extremes, there remains such a preponderance of ignorance in relation to essential factors, that the most vital question of all, site, is too often neglected.

In conclusion I would say to those who intend going in for Rhododendrons,—find out what varieties do best in your locality; keep strictly on those lines at the start; and then when you feel that you would like to add to your collection, try experiments. There are never two seasons quite alike, so that you can always count upon surprises, but never condemn a variety as not being hardy, unless you have given it the situation and careful attention which its constitution demands.

Wm. W. Brown.

North Easton, Mass.

Roses Under Glass

PLANTING.

The wretched condition of the rose market has doubtless caused many of the eastern growers to abandon all hopes of raising a return trip ticket to Europe on the old plants this season, therefore the general movement seems to be toward emptying and refilling the benches and planting the young stock with a view to being in line for the early fall market.

The work of planting is at any time tedious, to say the least, but when performed under the full glare of the June sun it is peculiarly enervating. Much of the physical discomfort attending re-planting may be overcome by shading the roof with a mixture of soil and water which may easily be applied with an ordinary spray pump.

Of great advantage to the men engaged in emptying and refilling the benches is a good and safe runway. It is at once pitiable and ludicrous to see a heavy man trying to walk bow-legged in order to maintain his equilibrium and that of his wheel-barrow on a 4-inch board; a 12-inch plank affords ample accommodation for the pedal extremities of an ordinary workman and is less likely to warp under the influence of the sun than the thin boards, the ends of which are genuine traps for the toes of the man with the wheel-barrow.

As soon as they are emptied and repaired, the benches, if wooden, should be thoroughly washed with a good force of water and then given an application of hot lime wash. This adds to the life of the wood and destroys fungous growth, insects, etc. The cracks in the bottom of the bench may be covered with old straw from the barnyard.

When the benches have been filled a sprinkling of bone meal may be added in the proportion of about twenty-five pounds to 500 square feet of soil surface. The planting should then be pushed forward as rapidly as possible, as the soil quickly dries and, aside from being disagreeable to handle, absorbs the moisture contained in the ball of the plant and often administers a severe check to the young aspirant for commercial favor.

Many failures may be traced to overcrowding the stock. This practice, while it may seem economical and proper to utilize every available inch of bench space, cannot but end in disaster. Plants, like human beings, require plenty of breathing space, and where this is denied them they fall easy victims to the attacks of black-spot, anthracnose and other fungoid diseases. Varieties such as Richmond, Killarney, Uncle John, etc., should have at least one square foot in which to grow, and if grafted stock is used they ought to have at least one-third more room. American Beauties can use one and one-half square feet of space, and if properly attended to will pay for it.

In planting grafted stock, it is advisable, if possible, to get the graft well under the surface of the soil, as it is there that the conditions of air and moisture best adapted to the welfare of this class of stock are to be found.

J. E. Simpson

Hydrocyanic Gas for White Fly

The white fly is very resistant to fumigants and for this reason tobacco, which will suffice for some greenhouse insects, is useless when used against this pest. The only fumigant which has been found to give good results is hydrocyanic acid gas. If this is used strong enough to kill all stages of the fly, the plants will be killed, so a weaker strength, which will kill certain stages and leave the plants uninjured is used, and this is repeated twice at intervals of two weeks to kill those that escaped the first treatment.

The first step in fumigation is to calculate the number of cubic feet contained in the house, not taking out any space for benches, etc. Probably the easiest way to do this is to draw an end view of the house and divide this into a number of rectangles and triangles by calculating the number of square feet in each and adding the results together the total number of square feet is obtained which multiplied by the length of the house gives the total cubic feet.

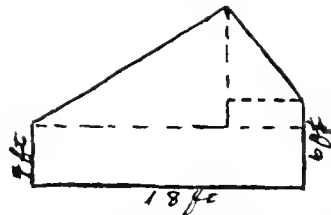

For example, the figure represents an end view of a house 100 ft. long, 18 ft. wide and 12 ft. to ridge. This is divided into two rectangles 4x18 and 2x5 and two right triangles whose bases are five and thirteen and whose heights are six and eight. The sum of the square feet of the rectangles is 82 and the sum of the square feet of the triangles is 67. The area of a right triangle being equal to one-half the product of the base times the height. This gives 149 sq. ft., which multiplied by 100 gives 14,900 cubic feet space in the house.

Hydrocyanic acid gas is generated by the action of sulphuric acid on potassium cyanide. The cyanide may be purchased at almost any drug store and must be 98-99 per cent. pure; the inferior 50-60 per cent grade will not do. Sulphuric acid may be obtained at the same place and should be of a sp. gr. of 1.83.

A number of vessels of earthen ware or granite should be obtained; the number depending on the size of the house. For the example quoted, three would be enough, one at each end and one in the middle.

Use one-third of an ounce of cyanide per thousand cubic feet, two times as many fluid ounces of acid and four times as many fluid ounces of water as there are ounces of cyanide. Calculate how much of each is to go into each jar, mix slowly the acid and water in each. Have the cyanide in paper bags suspended by strings directly above the jars and have the strings so fixed as to allow the bags to be dropped from near the door.

The house should be closed tightly before the gas is generated and one or two ventilators fixed so they may be opened from the outside. The plants should be dry and the fumigating done on a dark night. Leave the gas in the house about three hours, then ventilate. Do not under any circumstances enter the house before it is well aired.

All residue left in the jars should be buried where nothing will get at it as it is very poisonous.

John A. Summers

Mass. Agr. Exper. Station.

HORTICULTURE

VOL. VII JUNE 20, 1908 NO. 25

PUBLISHED WEEKLY BY
HORTICULTURE PUBLISHING CO.
 11 Hamilton Place, Boston, Mass.

Telephone, Oxford 292
 WM. J. STEWART, Editor and Manager

SUBSCRIPTION PRICE
 One Year, in advance, \$1.00; To Foreign Countries, 2.00; To Canada, \$1.50
ADVERTISING RATES

Per Inch, 30 inches to page \$1.00.
 Discounts on Contracts for consecutive insertions, as follows:
 One month (4 times) 5 per cent.; three months (13 times) 10 per cent.;
 six months (26 times) 20 per cent.; one year (52 times) 30 per cent.
 Page and half page spaces, special rates on application.

Entered as second-class matter December 8, 1904, at the Post Office at Boston, Mass., under the Act of Congress of March 3, 1879.

CONTENTS

COVER ILLUSTRATION—President-elect Chas. J. Brown.....	
NOTES FROM THE ARNOLD ARBORETUM—Alfred Rehder.....	813
THE HARDY RHODODENDRON QUESTION—Wm. McM. Brown.....	813
ROSES UNDER GLASS—J. E. Simpson.....	815
HYDROCYANIC GAS FOR WHITE FLY—John N. Summers.....	815
AFTER ADJOURNMENT.....	817
FREIGHT RATES ON B'LBS.....	817
NEWS OF THE CLUBS AND SOCIETIES:	
Gardeners' and Florists' Club of Boston—Meetings Next Week—Tarrytown Horticultural Society Massachusetts Horticultural Society—St. Louis Florist Club.....	818
American Association of Park Superintendents—Pittsburg Florists' and Gardeners' Club—American Association of Nurserymen.....	819
Club and Society Notes.....	820
PARIS SPRING SHOW—C. Harman Payne—Illustrated.....	822
DURING RECESS.....	824
SEED TRADE.....	825
OF INTEREST TO RETAIL FLORISTS.....	826
Steamer Departures—New Retail Flower Store.....	826
OBITUARY—Lawrence Lundberg, portrait—A. David Rose, portrait—Alexander Wallace—Ira L. Russell—Wm. Barr.....	827
FLOWER MARKET REPORTS:	
Boston, Chicago, Indianapolis, New York, Philadelphia, Twin Cities, Notes.....	829
MISCELLANEOUS:	
Personal.....	817
The Lily Bulb Situation.....	817
A Song for June, Poetry.....	817
Business Changes.....	819
Movements of Gardeners.....	824
List of Patents.....	824
Catalogues Received.....	824
Incorporated.....	825
Philadelphia Notes.....	829
News Notes.....	836
Fire Record.....	836
Spring Plant Notes.....	837
Greenhouses Building or Contemplated.....	837

staples seem to be now pretty well assured. The occupation of the pessimists is about gone and they have ceased to tell us that "hard times are only just beginning," for, in the face of our glorious agricultural prosperity, nobody will believe them. This prevalent confidence is a most excellent symptom. We hope to see it extend in fullest measure to the flower trade, which has suffered its full share of the adversity of the past season. As compared with the outlook of a few months ago there is today every cause for hopefulness and every encouragement for all to get a move on, eager for the prosperity which is now coming along at full speed.

Unappreciated flower shows

A trade visitor in Boston who took opportunity to attend the recent rhododendron show at Horticultural Hall expresses astonishment at the indifference of the Boston public to this really beautiful exhibition as evinced by their almost entire absence from the hall although the announcement was placarded outside that admission was free. Although in this special instance the fete at Holm Lea was undoubtedly the cause of the absence of many on Saturday and notwithstanding that on Sunday the halls are generally crowded in mid-afternoon yet we have to acknowledge that the criticism is, in the main, well-founded. The apathy of the people to such an attraction is hard to understand and it is not limited to Boston. When florists and the gardeners from suburban estates undertake to transport and stage their products for the pleasure of the public, at much expense and loss of time, it is very disheartening to have the effort go unappreciated and a very strong argument is presented in support of the contemplated reduction in the number of summer free shows given by the Massachusetts Horticultural Society and the concentration of effort on a limited number of spectacular affairs during the inclement season of the year to which an admission fee shall be charged.

Nurserymen headed right

The nurserymen, in their convention at Milwaukee last week, showed by their discussions and resolves that they are thoroughly awake to the glorious business possibilities that lie within their reach and also to the menaces that exist in ill-advised hasty legislation in which their interests are involved and in the reprisals which the transportation companies are so ready to make wherever they think they can find a victim unprepared to resist. We particularly like the sentiments which President Hill expressed concerning forest preservation and would also especially commend to every one in the nursery trade his straightforward advice on the subject of advertising. A more general adoption of liberal advertising methods throughout the season would do much to keep stock moving in a legitimate way, and go far to eliminate the "surplus stock" sales at the end of the season of which President Hill and many others complained. An industry having, as President Hill informed us, more than sixty million dollars invested, giving employment to fifty-five thousand men and three thousand women and devoted to "the noble vocation of bettering and up-lifting mankind," is surely entitled to the advantages of the most modern business facilities, and President Hill is unanswerably right when he places enterprising and truthful advertising at the head of the list.

Reports from all agricultural sections continue favorable. The condition of crops on June 1, as found by the Bureau of Statistics of the U. S. Department of Agriculture in every section of the country shows in practically every item throughout the list of fruits and cereals a largely increased percentage not only over last year but over the average for ten years and "bumper" crops in all "bumper" crops and good times on the way

AFTER ADJOURNMENT.

Attention is called to the information given on this page concerning freight rates on bulbs from Ollionles, Rotterdam and Yokohama.

So long as dealers in one place are short of material which in another place is at the same time over-stocked and being sold at sacrifice figures or going to waste, the assertion stands good that there is something wrong at one end or the other. One of the main factors in "the art of selling" is to wake up the dormant business.

It has been said that "show windows are the eyes of a store." Keep the "eyes" open and bright even though there be little going on in the summer days now coming. The store-keeper who neglects his windows is liable to be neglected by the customers later on. This is a case where a good front is never an extravagance.

Watch our Buyers' Directory and Ready Reference Guide. There are quite a number of small advertisements there from firms that will appear with big ones next season after they have come to realize how good the response from the buyers is even when the offer is a wee one. And when you buy don't fail to tell them that "HORTICULTURE did it."

Have you a surplus of anything for which the selling season is waning? Advertise it now, as a surplus, and at a price that will turn it into cash for you and enable it to make a profit for the buyer who takes a chance on it. People don't know you have bargains for them unless you tell them. Never throw anything away which somebody else may have use for.

Train your customers to prompt settlements and adopt the same policy yourself in paying bills, to the greatest possible extent. A small amount of money will pay a big lot of bills if permitted to circulate. If everybody wouldn't "get the habit" we should all be happier and the flower trade, bulb trade and nursery trade would all stand far better commercially. Six and twelve month credits are a heavy weight for any business to carry.

The merchants' associations and large shippers are up in arms against the recently announced general advance in freight rates. Instead of going up it would seem that freight rates ought to go down and it is not easy to resist the conviction that the present course of the railroads suggests more of retaliation than of justice. Here in New England we have just escaped the regularization of a most dangerous railroad monopoly. The American cultivator, in commenting on the recent manoeuvres in Massachusetts says that "President Mellen is deemed by his admirers the most efficient railroad president in the United States," but that he "has evinced an inadequate conception of the importance of retaining favorable public sentiment." We would add that it exasperating the public by holding them up at every available turn in efficiency, then judged by this test President Mellen has achieved a notable success during the few years since he ascended the throne.

PERSONAL.

Jesse F. Arlin has resigned his position at the Davis greenhouses, Dover, N. H.

R. Vincent, Jr., of White Marsh, Md., has returned from his trip abroad.

M. Norbert Levayasseur has been elected Mayor of Boulon, near Caen, France.

George McWilliam, of Whitinsville, Mass., with his wife, sailed on June 2 for a visit to Scotland.

Philip Einsman, of Long Island City, N. Y., will sail for Bremen on the Kaiser Wilhelm II, June 23.

August Muller, of Philadelphia, is famous for his choice strain of verbenas. His father before him was also a celebrity in this line fifty years ago.

Visitors in Boston: S. S. Skidelsky, Philadelphia, Pa.; H. S. DeForest, representing Pierson U-Bar Co., New York; Prof. L. R. Taft, Agricultural College, Mich.; George F. Struck, of Knight & Struck, New York; R. M. Grey, Cuba.

Chicago visitors this week: Edw. Amerpohl, Janesville, Wis.; Thos. A. Macheh, Springfield, O.; Elmer D. Smith, Adrian, Mich.; F. J. Olson, Ames, Ia., buying glass and building material for two new greenhouses; R. Dintleman, Belleville, Ill., en route from nurserymen's convention.

THE LILY BULB SITUATION.

We quote from the June market report of R. M. Ward & Co., New York, the following notes on present condition and prospects of supply and demand on various florists' lily bulbs:

Lilium Harrisii (August delivery); crop is improving.

Japan Lilies.—Longiflorum (Sept., Oct.), small demand. Multiflorum (Sept., Oct.), moderate demand; crop is improving. Giganteum (Oct., Dec.), strong demand; early orders advised; large sizes scarce. Auratum (Oct., Dec.), demand is increasing. Speciosum Album (Oct., Dec.), scarce; early orders advised. Speciosum Rubrum (Oct., Dec.), moderate demand. Speciosum; Magnificum (Oct., Dec.), demand is increasing. Speciosum Melpomene, or Roseum (Oct., Dec.), small demand.

Formosa Lilies (July, Aug.), early orders advised; quantities of large sizes limited.

A SONG FOR JUNE.

'Tis June! the glad time when I found thee,
Of thou, my sweet flower of love!
The dear olden glimmer is 'round thee,
The same tender sky bends above,
New beauties the summer discloses,
But none that can rival thee now;
Not one of its fairest young roses
Is perfect as thou.

One June brings the red rose of passion
And marks its frail beauty decline,
But June upon June could not fashion
The rose of a love such as thine,
Not long in the gardens of pleasure
Are love's sweetest flowers possessed;
The love that hath leavening measure
Of sorrow is best.

This June its new beauties discloses,
But none that can rival thee now,
Not one of its fairest young roses
Is perfect as thou.

T. A. DALY

FREIGHT RATES ON BULBS.

We have compiled for the benefit of our readers who buy French, Dutch or Japanese bulbs, the following information concerning transatlantic and overland freight rates which will, perhaps be found worthy of a careful perusal.

Rate sheets of freight on bulbs from Ollionles via Marseilles by Nor. Deutscher Lloyd or Fabre line per 1000 Kilo to New York, Boston and Philadelphia and inland cities by through bill of lading all rail from New York are quoted as follows:

	Lots of 50 Parcels	Lots of 50 lbs.	Tons of 12 Cts.
New York	50 fr.	49 fr.	46 fr.
Boston	98 ..	97 ..	68 ..
Philadelphia	114 ..	113 ..	69 ..
Chicago, Louis-ville, St. Mil-waukee	137 ..	136 ..	80 ..
Rochester	91 ..	90 ..	62 ..
Syracuse	91 ..	90 ..	62 ..
Pittsburg or Erie	102 ..	101 ..	65 ..
Albany	86 ..	85 ..	62 ..
Chicoutimi	127 ..	126 ..	75 ..
East St. Louis	150 ..	155 ..	86 ..
Toronto	108 ..	107 ..	73 ..
St. Paul	197 ..	196 ..	102 ..
Richmond	101 ..	100 ..	72 ..
Buffalo	96 ..	95 ..	64 ..
Toledo, Colum-bus or Detroit	120 ..	119 ..	72 ..
Indianapolis	132 ..	131 ..	78 ..
Orlando	112 ..	111 ..	79 ..

100 Kilo is equal to 220 pounds avoirdupois. The average full-size French bulb case, full, weighs about 75 Kilo. Shipments by the Fabre line are preferred.

Better rates for Holland bulbs are afforded by the Cosmopolitan Line via Philadelphia than via the Rotterdam Line especially when quantities are shipped. Carload rate from Rotterdam to Chicago via that route is 62 cents per 100 lbs., whereas the rate from New York to Chicago alone is more, viz., 75 cents per 100 lbs. The Dutchmen, we believe, get no rebates via Philadelphia and consequently do not ship that way unless so instructed.

The Great Northern Railway Railway Co. has announced the fact that the present freight rate from Yokohama to New York, Chicago and other inland cities, will be abolished June 30th and a new tariff will be issued July 1st to conform to the rules and regulations of the Interstate Commerce Commission. This will greatly affect the cost of Japanese bulbs, plants, etc., which have heretofore enjoyed an extremely low freight rate considering the distance covered, or \$1.25 to \$1.50 per 100 lbs. from Yokohama to New York. The rate on the same goods from Pacific Coast ports is \$3.00 per 100 lbs. to New York via the same route; and should the Interstate Commerce Commission raise the rate accordingly, it would make a difference in the cost of Japan Lily bulbs of from \$10.00 to \$20.00 per 1000, according to sizes of the bulbs. Shipments via Suez are impractical. The matter of freight rates from Japan is therefore of much importance to the importers and the final decision of the I. C. C. is awaited with interest.

I am compelled to ask you to discontinue my ad. for chrysanthemum cuttings as I have now as many orders as I will be able to fill.

H. L. CAMERON,

No. Cambridge, Mass., June 4, 1908.

NEWS OF THE CLUBS AND SOCIETIES.

GARDENERS' AND FLORISTS'
CLUB OF BOSTON.

At the meeting of the Gardeners' and Florists' Club at Horticultural Hall, Boston, Tuesday evening, June 16, Mr. A. H. Kirkland, Superintendent of the gypsy moth work in Massachusetts, gave an interesting discussion of the work being done by the department of which he is the head. He touched briefly on the principal factors which had led to an increase in insect damage within comparatively recent years, the three most important being the massing of a single species of shade tree or crop over large areas, thus giving abundance of food for certain insect pests; the importation of the English sparrow, which has crowded out our native insectivorous birds, and the importation of insect pests from abroad which have left behind the natural enemies which check their increase in their native environment. Of the latter insects, the gypsy and brown-tail moth, the leopard moth and the San Jose scale were cited as illustrations. The speaker fully described and explained the working of the present gypsy moth law, which has brought about co-operative efforts on the part of the property owners, the city or town and the state. He estimates that at least \$750,000 was expended in the work against the moth pests from these three sources during the year 1907. The methods of work against the insects were fully described, and particular attention given to the discussion of spraying operations, which under favorable conditions give the best results of any single method. Over 150 tons of Arsenate of Lead will be used in spraying operations this summer, the poison being applied at the rate of 10 pounds to 100 gallons of water. This insecticide has the advantage of adhering firmly to the foliage in spite of rains, and hence is effective for a long time.

The work of importing parasites of the gypsy and brown-tail moths from abroad was gone into detail, and the speaker stated that 8 or 10 important parasites of these insects in Europe had now become successfully established in Massachusetts. He felt quite sanguine that in the end these parasites would bring about the substantial control of these pests, but stated that for the next few years mechanical methods must be used with all possible vigor to keep the insects under control.

The occurrence of the leopard moth and other European pests of shade trees in Massachusetts was reported, and the life history of the insect described. This borer is not especially injurious in out-lying sections where native insectivorous birds such as woodpeckers and chickadees have a chance for their life. It has been and is highly injurious in such thickly settled centers as New York, Brooklyn, Jersey City, Newark and vicinity, where the English sparrow has driven out the native birds. It occurs in Boston in the trees on the Common and Public Gardens, at Louisburg Square and on Commonwealth Avenue. The only remedy of value so far discovered is to remove the broken

infested limbs and burn them in June before the borers have transformed into moths.

As against the rather discouraging announcement of this imported pest, which was unknown in Massachusetts up to last year, the speaker stated that the elm leaf beetle, which has been doing so much damage in Eastern Massachusetts during the past two years, would probably subside after 1908, and its outbreaks seldom extend over three years. A thorough spraying of the infested elms in early June with Arsenate of Lead has proved an entirely satisfactory remedy for the insect.

The lecture, which was well received, was finely illustrated by a large number of lantern slides showing the different insects discussed, and the apparatus used in combating them.

Secretary W. N. Craig took up the defence of the English sparrow which, he said, was the only bird which would devour the pupae of the elm leaf beetle, and the currant worm, and would also eat the cut worm. From a gardener's



Newport, R. I., June 23, 24, Newport Horticultural Society, rose and strawberry show.

Detroit, Mich., June 23-25, American Seed Trade Association, annual convention.

Boston, Mass., June 20, 21, Massachusetts Horticultural Society, rose and strawberry show.

standpoint he had discovered no harm in this bird, and regards it as a friend. In reply to a question, Mr. Kirkland said that the eggs of the leaf miner, which had done so much injury to the hawthorns, are laid on the outside of the leaf and as soon as hatched out the grub burrows in the leaf where he cannot be reached by any insecticide, but that if the foliage is thoroughly sprayed before the eggs hatch no doubt good results would follow. On the exhibition table were some blooming plants of Farquhar's hybrid lilies (*Philippinense* x *longiflorum*), one plant 14 months and 20 days from seed with two spikes of four flowers each, this being the second blooming of this bulb. Wm. Downs showed some superb tomatoes grown from a new strain, introduced by Farquhar, but as yet unnamed. Wilfrid Wheeler had an exhibit of fine strawberries in six varieties.

The schedule of prizes offered by the New England Dahlia Society for its first annual exhibition at Tremont Temple, Boston, has been received. The dates for the show are September 17, 18 and 19. There are 89 regular classes in addition to numerous special prizes, 10 per cent. entrance being required in the former. Copies may be had from Maurice Fuld, secretary, 5 Union street, Boston.

TARRYTOWN HORTICULTURAL
SOCIETY.

The annual June exhibition of the Tarrytown Horticultural Society held in the Music Hall on Friday, June 12, has eclipsed all previous ones, a magnificent display of roses in perfect shape and colors and staged on five large tables. One exhibitor alone had over one hundred varieties of Hybrid Perpetuals and Teas, the majority of them correctly named. Frau Karl Druschki was very much in evidence, having been entered in many classes and carried the honors wherever perfect. Competition was very keen in every class and judging difficult.

Strawberries were also fine, large and well-finished, every class heavily catered, single plate entries numbering eleven and the majority of them perfect in every way. Shrubs were lacking, only two exhibits being staged with common varieties.

Perennials were fine, two exhibitors having over 50 varieties each, well-labelled. The F. R. Pierson Co. had some large exhibits of miscellaneous plants and cut flowers, not for competition, but very interesting.

An innovation which proved successful and interesting was the giving of two prizes for bouquets of wild flowers, open only to school children under 14 years of age. This brought 24 contestants. The judging was eagerly watched by the young contingent.

Certificate of merit was awarded to F. R. Pierson Co. for miscellaneous exhibits and to Mathew J. Muartha, gardener to Mrs. W. L. Bull, Irvington, N. Y., for shrubs, hardy perennials and roses. Cultural certificate to George Whittinger, gardener to Miss Blanche Potter, Ossining, N. Y., for collection of vegetables, and John Elliott, gardener to Geo. Legg, Tarrytown, N. Y., for rose Frau Karl Druschki. Honorable mention to Wm. Jameson, gardener to Emil Berolz-leimer, Tarrytown, N. Y., for Melon "Blenheim" and Tomato "Lorillard," and to Francis Gibson, gardener to Mrs. J. B. Hall, Tarrytown, N. Y., for shrubs, hardy perennials and roses.

Following are the prize awards:

Collection of flowers cut from hardy perennials, F. L. Milne, gardener to E. H. Weatherbee, Mamaroneck, N. Y. Strawberries, 3 varieties, W. H. Waite, gardener to S. Untermyer, Yonkers, N. Y. Strawberries, 2 varieties, W. C. Roberts, gardener to Frederick Potter, Ossining, N. Y. Strawberries, any one variety, Wm. Jameson, gardener to Emil Berolz-leimer, Tarrytown, N. Y. Strawberry, "Marshall," James Stuart, gardener to Mrs. F. A. Constable, Mamaroneck, N. Y. Vase 25 Hyb. Perpetual Roses, John Woodcock, gardener to E. A. McAlpin, Ossining, N. Y. Collection of out-door Roses (silver cup), John Woodcock. Out-door Roses, 6 varieties, John Woodcock. Roses, 3 varieties, John Elliott, gardener to George Legg, Tarrytown, N. Y. 12 Roses, any one variety, H. Nichols, gardener to Mrs. J. B. Trevor, Yonkers, N. Y. Vase of Roses, John Elliott, Tarrytown, N. Y. Display Climbing Roses, John Brunger, gardener to J. N. Seligman, Irvington, N. Y. Collection flowers from hardy shrubs, W. H. Waite, Yonkers, N. Y. Sweet Peas, H. Nichols, Yonkers, N. Y. 12 varieties Vegetables, H. Nichols, Yonkers, N. Y. 6 varieties Vegetables, John Brunger, Irvington, N. Y.

MASSACHUSETTS HORTICULTURAL SOCIETY.

Annual Peony and Rose Exhibition.

Horticultural Hall, Boston, presented a gorgeous picture on Saturday and Sunday, June 13 and 14. In all respects it was the finest display at this date in many years. "Flowers fit for Paradise" were there in profusion and perfection and if the peony dealers don't find an enormously increasing demand for their choice things the coming season it will not be Boston's fault.

It was rather early for the outdoor roses, which will be much better, no doubt, at the rose and strawberry show one week later. But the various rose display classes were well filled and the quality of the flowers was excellent for the season. The peonies were the chief centre of attraction. Exhibitors were numerous and practically every variety shown had a name attached. E. J. Shaylor & Son made a phenomenal display including many superb novelties, among which Georgiana Shaylor, a wonderfully beautiful seedling of Daybreak pink color, shone with transcendent lustre. Mr. Shaylor has a light, clean soil at his plantation in Wellesley Hills and peonies seem to revel in it. He lives for them and takes care of them and could cut 10,000 flowers at present writing without missing them. Another premier exhibitor was R. & J. Farquhar & Co. who staged an extensive collection comprising fully one hundred vases of from six to fifty blooms each, among which were several seedlings of exceptional merit. T. C. Thurlow & Co. were represented in practically every class in the schedule and won the majority of the first prizes with well-balanced selections. George Hollis, well-known as a peony enthusiast, showed fifty varieties, of which about one-half were seedlings, among which Admiral Togo, dark crimson, Aristocrat white flushed, and twelve Lew seedlings under number figured. A. H. Fewkes, William Whitman gardener Martin Sullivan, Dr. Charles Minot, Frederick Mason gardener F. L. Lewis, James McKissock (74 varieties), and Mrs. J. L. Gardner gardener Wm. Thatcher, were all represented by superb groups and vases.

A list of a few of the varieties that might well be termed top-notchers may prove useful to our readers. Among the best, but by no means an unrivalled list, we should place Theresa, rose pink; Felix Crousse, crimson; Aurora, white and soft pink; Edouard Andre, carmine; M. Mechin, very dark; Germaine Bigot, light pink with touches of dull red. James Kelway, a noble broad-petaled white; Eugene Verdier, soft pink; Baroness Schroeder, flushed white; Avalanche, clear white; Mme. Emile Lemoine, broad-petaled blush; Marguerite Gerard, pink, high-built flower; Rosa Bonheur (Dessert novelty), delicate mauve pink; Mme. de Trevevan, light pink with occasional dark streak; Pottsi alba, old but invincible; Souvenir de Exposition de Universalle, unique Killarney-rose pink; Albatre, white with occasional penciling of crimson on edge of petal; Chas. Verdier, dark pink; Mme. Lemoine,

full pink; Couronne d'Or, white with crimson markings on edge of centre petals. Among the most beautiful flowers was A. B. Gould, the best of the famous Richardson seedlings. In many collections this is said to figure as Milton Hill, another Richardson seedling of entirely different character. It is not so well known as it should be that in peonies the variance between crown buds and laterals is fully as great as in chrysanthemums and that, to get best results in blooms for exhibition disbudbing is always necessary.

The prize awards which we give below designate the winners in the general rose displays. Especial credit is due to Mrs. Aaron Ward, Roslyn, N. Y., for her extensive collection of H. T. varieties. In the miscellaneous classes the hardy herbaceous flowers from Blue Hill Nurseries were prominent. Philadelphus Lemoine Mantau d'Hermine bearing a profusion of small pure white flowers, and Lupinus Polyphyllus Marheimii were sterling novelties, the latter being a soft pink flower with bright tipped standard. Sweet Williams were shown in sparkling array by Wm. Whitman, hardy perennials by W. W. Rawson & Co., and Spanish Iris by J. T. Butterworth. From Harvard Botanical Garden came the insectivorous plants, droseras and dionaeas, and the sensitive mimosa and these proved to be of un-failing interest to visitors. W. Whitman's pyrethrams were very fine. A first class certificate of merit was awarded to E. J. Shaylor for peony Georgiana Shaylor, and honorable mention to R. and J. Farquhar & Co. for displays of peonies.

The prizes awarded were as follows:

Roses—Theodore Lyman, special for hardy roses to W. J. Clemson gardener for J. O. Christenson, J. C. Chaffin special for best white H. T. rose to E. E. Lincoln for Frau Karl Druschki. Twelve named varieties, three of each: 1st, E. E. Lincoln; 2nd, W. J. Clemson; 3d, Mrs. Aaron Ward. Six named varieties, three of each: 1st, W. J. Clemson; 2nd, Mrs. Aaron Ward. Twenty-four named varieties, one of each: 1st, Wm. Whitman; 2nd, Mrs. Aaron Ward. Twelve named varieties, one of each: 1st, Mrs. Aaron Ward. Best collection of H. T. roses: 1st, Mrs. Aaron Ward. Best three blooms of a variety introduced since 1903: 1st, W. J. Clemson. Six blooms of Frau Karl Druschki: 1st, W. J. Clemson. Six blooms of Mrs. R. G. Sharrow Crawford: 1st, E. E. Lincoln. Six blooms of Margaret Dickson: 1st, W. J. Clemson; 2nd, E. E. Lincoln. Six blooms of any other variety: 1st, W. J. Clemson; 2nd, Mrs. Frederick Ayer; 3d, ditto. General display One hundred bottles of hardy roses: 1st, W. J. Clemson; 2nd, Mrs. Frederick Ayer; 3d, Mrs. E. M. Gill; 4th, Mrs. J. L. Gardner; 5th, Col. Frederick Mason.

Sweet Williams.—Display, eighteen vases of three trusses each: 1st, Wm. Whitman; 2d, Mrs. J. L. Gardner. Hardy Herbaceous Flowers.—Thirty bottles, distinct species and varieties, not less than ten genera, 1st, Blue Hill Nurseries. Peonies. Collection of thirty or more varieties, double: 1st, T. C. Thurlow & Co.; 2d, James McKissock; 3d, George Hollis; 4th, E. J. Shaylor. Collection of twelve varieties, double, three flowers of each: 1st, Wm. Whitman; 2d, E. J. Shaylor; 3d, George Hollis. Specimen bloom, double: 1st, James McKissock; Therese; 2d, George Hollis, Aristocrat. Collection of twelve or more varieties, single: 1st, T. C. Thurlow & Co.; 2d, George Hollis. Collection of twelve or more varieties, Japanese single: 1st, George Hollis. Vase of blooms on long stems, arranged for effect: 1st, Mrs. J. L. Gardner; 2d, Dr. C. G. Weld. Collection of six double varieties, white: 1st, T. C. Thurlow & Co.; 2d, J. L. Blanchard; 3d, Dr. Charles S. Minot. rose pink, 1st, T. C. Thurlow & Co.

salmon pink: 1st, T. C. Thurlow & Co.; red or crimson: 1st, T. C. Thurlow & Co. Vase of twenty five blooms, double, white or bluish: 1st, T. C. Thurlow & Co.; Festiva maxima; 2d, the same for M. Juppert; 3d, E. J. Shaylor, Baroness Schroeder; pink or rose: 1st, E. J. Shaylor, Pottsi alba; 2d, T. C. Thurlow & Co., Medeste (Guerin); 3d, Wm. Whitman, Lady Bramwell; red or crimson: 1st, T. C. Thurlow & Co., Felix Crousse; 2d, Wm. Whitman, Louis Van Houtte; 3d, Col. Frederick Mason, Triumphe de Nord. For non-commercial growers only. Collection of twelve named varieties, double: 1st, J. L. Blanchard; 2d, Wm. Whitman; 3d, Mrs. J. L. Gardner.

The annual rose and strawberry show of the Massachusetts Horticultural Society will be held at Horticultural Hall, Saturday and Sunday, June 20 and 21.

A special feature of this exhibition will be a magnificent display of hardy roses and hybrid tea roses, filling five hundred vases, from the noted estate of Miss Sarah B. Fay, of Woods Hole. This display will be in charge of M. H. Walsh, who will exhibit also some of his own productions which have made his name familiar to all rose growers the world over.

The exhibition which is free to all will be open Saturday from 12 to 6 and Sunday from 2 to 6 o'clock.

WM. P. RICH, Sec'y.

ST. LOUIS FLORIST CLUB.

A largely attended meeting greeted President Young last Thursday afternoon when the Florist Club held its regular monthly meeting. All the other officers put in their appearance and the meeting throughout was interesting. The trustees reported that they had made all arrangements for the annual picnic for the members and their friends, the place selected being Normandy Grove and the date July 15th. This was acceptable to the members and the report adopted; they were requested to bring in a fully arranged program at the next meeting. Several members present offered special trophies for the picnic. The president appointed a committee of three consisting of Messrs. Ammann, Peneke and Guy to draw up suitable resolutions on the death of William Scott, this being the first meeting since the death of Mr. Scott. Harry Balsley of Detroit, Mich., was present and gave an interesting talk on his travels throughout the country and the business done by others as he saw it.

The next meeting, July 9th, should be largely attended and made interesting as the nomination of officers will take place and there are several candidates for the different offices, especially for those of president, secretary and treasurer.

BUSINESS CHANGES.

C. W. Blatchley has purchased the flower store of Mrs. Lilian Savage, Southington, Conn.

Albert Warner has purchased the Dow greenhouses, Indianapolis, and will take charge of same at once.

Jontry Bros. (M. C. and J. F. Jontry) is the name of the firm succeeding to the business of H. W. Jontry, Chenoa, Ill.

The greenhouses of Coolidge Bros., South Sudbury, Mass., are to be opened up and run in the interest of the mortgage.

AMERICAN ASSOCIATION OF PARK SUPERINTENDENTS.

Preliminary Program.

The American Association of Park Superintendents will hold its annual convention in Minneapolis, Minn., August 11, 12 and 13, and the Park Board of the convention city has appointed a special committee of five members and the superintendent to work out an interesting program and provide for the welfare and entertainment of their visitors.

The association has never met further west than Buffalo, and Minneapolis will spare no pains to justify its claim as the ideal convention city of the great Northwest. As a park city, Minneapolis stands second to none in the country, and while its system of parks and parkways is far from completion and perfection as compared with the systems of the older cities of the East, the possibilities offered by its present park possessions and through contemplated extensions, will convince every visitor that Minneapolis will have one of the grandest systems of parks, parkways and boulevards in the country.

The many fine lakes, the grand drives along the wooded banks of the Mississippi River and Minnehaha Falls and Creek, the many parkways through the residential parts of the city and the many smaller parks, must of necessity attract and gratify every visitor interested in park work and development.

The following preliminary program has been prepared and will, in the main, be carried out:

Headquarters.—West Hotel, Hennepin Avenue and Fifth street. Rates \$1.50 and up.

First Day—Tuesday.

9:25 A. M. Opening of session, Park Commissioners' Office, City Hall. Address of welcome by His Honor, the Mayor, James C. Haynes, and Hon. Jesse E. Northrup, President of the Board of Park Commissioners. Response by J. E. Cowell, President of Park Superintendents. Business meeting.

12:15 P. M. Automobile ride to Minnehaha Club, Lake Calhoun.

12:45 P. M. Luncheon at club house.

2:00 P. M.—Reading of Essays and discussions at the club house. (An interesting program for this session is being prepared, and the names of the essayists and the subjects of the essays will be sent out with the final program some time in July.)

7:00 P. M. Start from hotel by trolley car for Lake Harriet. Concert and sail on lake.

Second Day—Wednesday.

9:00 A. M. A thirty-five mile automobile trip around the Park System.

12:30 P. M. Luncheon at Minnehaha Pavilion.

1:30 P. M. Photo taken at foot of Minnehaha Falls. Stroll through Glen and Park.

2:30 P. M. Continue automobile ride.

8:00 P. M. Banquet.

Third Day—Thursday.

9:00 A. M. A trip to Minnesota's finest lake resort at Lake Minnetonka.

10:00 A. M. Arrive at Excelsior special boat for two hours sail around Lake Minnetonka.

12:30 P. M. Luncheon at Big Island or Tonka Hotel.

3:00 P. M. First business session.

Lake Minnetonka, with its water area of 39 square miles, its 110 miles of wooded and open shores and back-

ground of rolling land, its numberless bays, narrows and islands, is the most picturesque of the thousands of named lakes in the State of Minnesota. It is one great park, attractive and fascinating from every point of view.

The Park Board and different organizations of the Convention City will act as hosts of the society, providing for the entire entertainment herein outlined.

The West Hotel, selected as headquarters, is centrally located within ten blocks of all the railroad stations and five minutes walk from the City Hall.

It was originally intended to make this convention a Twin City affair, but the St. Paul authorities withdrew from participation and may extend a separate invitation to visit their park system. For that purpose the fourth day of the original mapped out four day meeting, would be available.

PITTSBURGH FLORISTS' AND GARDENERS' CLUB.

The regular monthly meeting of the Club for June 2d was postponed to June 9th, in order that outdoor roses and peonies might be at their best. The postponement proved to be a mistake, however, as the fierce heat of the last days of May threw the peonies into flower and they were past their best at the date of our meeting, with the earlier sorts entirely out of bloom. Roses, too, were none too good. The president appointed as judges of the exhibit: P. S. Randolph, J. W. Ludwig and J. W. Jones, who awarded first prize of \$10 for the best twelve outdoor roses to N. C. Madsen, gardener for R. H. Boggs, Sewickley, Pa.; second prize of \$5 to Robt. Lilley, gardener for Mr. Barnsdale, Pittsburgh. There were no peonies shown that the judges considered worthy of first prize.

The second prize for the best twelve was awarded to N. C. Madsen. Frank Crook, gardener for I. H. Parks, showed a very fine large *Adiantum*, which was specially commended by the judges. Fred Wissenbuch, gardener for W. L. Mullen, showed a collection of roses, delphiniums, foxgloves, etc. Phipps' Conservatories showed exceedingly fine foxgloves, and a good collection of herbaceous material.

The matter of the club outing was decided in favor of Bakerstown, on the grounds of the Pittsburgh Rose and Carnation Co. Mr. E. Burki, who is president of this company, as well as of our club, extending a kind invitation to the club to avail itself of his hospitality. The date was set for June 15 a basket picnic. This affords a rare chance for our members not only to have a pleasant outing, but also to inspect the large and thoroughly modern plant of the Pittsburgh Rose and Carnation Co. J. W. Jones, P. S. Randolph and J. W. Ludwig are the committee in charge. Subject for the next meeting: "Herbaceous Plants and Flowers."

H. P. JOSLIN, Secretary.

AMERICAN ASSOCIATION OF NURSERYMEN.

Convention Report Continued.

HORTICULTURE'S early report of the proceedings at the Milwaukee convention gave much pleasure to many members who were obliged to forego attendance at the convention and was a very complete although brief account of the meetings up to Thursday noon. Thursday afternoon's proceedings were mostly behind closed doors and not of general interest outside the membership of the Association.

On Friday morning the party, numbering about 475, started in three trolley cars for Oconomowoc, a ride of about fifty miles through rolling farming country interspersed with patches of woods and the larger part of the way in sight of beautiful lakes, the shores of which are the summer homes of Milwaukee and Chicago people. A stop was made at the farm of Mr. Fred Pabst, a very wealthy scion of the well-known brewer famous everywhere. At this farm are gathered together as choice hackneys as the world has produced, and the most renowned of them were brought out and put through their paces, and rounds of applause greeted the performance. There were on the farm 200 hackneys and on another farm Mr. Pabst has over 2000 Percheron brood mares. Mr. Pabst had thrown open his mansion to his guests but lack of time prevented accepting the invitation. At Oconomowoc arrangements were perfect for giving dinner to the good-natured throng, and in the afternoon carriages, automobiles and steamers were free to the guests of the city to take them on drives of many miles along the lake shores. Nothing was lacking to make a delightful summer outing. Oconomowoc is a charming old summer resort in a cluster of lakes, and all who were in the party carried back with them a memory of typical Wisconsin rural scenery. One of the party, Mr. Hooker, of Perfection currant fame, whose long trip from his Rochester home was principally undertaken for the purpose of seeing the Pabst stud of hackneys, was in a particularly beatific state of mind.

Notes of the Exhibition.

A notable feature of the exhibition in connection with the nurserymen's meeting at Milwaukee was the new Reed-Bell graft-wrapping machine. In looking at the machine in operation one's doubt as the practicability of doing this work by a machine vanishes at once. An operator can do from 5,000 to 15,000 grafts a day, and do every one alike and far better than they are done by hand. The use of such a hard and unyielding wrapper overcomes the hard crown gall so often produced at the junction. This is nothing more than an overgrown callous knot, an overflow of repair tissue. This machine was invented by Mr. Bell of the Huntsville Nurseries, and his invention joined with decided improvements in details of operation, made by Mr. Reed, superintendent of the Stark Bros. Nursery, is a machine that no nurseryman should be without.

D. Hill of Dundee, Ills., had some fine specimens of evergreens and Ell-



Do Not Miss It

IT WILL NOT BE REPEATED

An excellent opportunity afforded you. Take advantage of it.
TUESDAY, JUNE 23, NOON
 We offer a fine collection of stock suitable to grow on, consisting of

Ferns, Ficus, Asparagus, Palms, Cocos, Crotons, Chrysanthemums and Assorted Table Ferns

W. ELLIOTT & SONS, Auctioneers, 42 Vesey Street, New York

wanger & Barry furnished the chief decoration with a group of beautifully grown Japanese maples. They grow these maples in boxes that will allow shipping the plants at any season without the least injury.

CLUB AND SOCIETY NOTES.

The annual meeting of the Society of Iowa Florists will be held in Des Moines in August.

Since May 1, 1908, Secretary Esler, of the Florists' Hail Association, has adjusted an average of one loss per day.

The Twin City Florists' and Gardeners' Club is considering the advisability of incorporating as a Minnesota state organization.

President Traendly has appointed Mr. V. E. Lambert, of Atlanta, Ga., as State Vice-President of the S. A. F. for the State of Georgia.

The next meeting of the Albany Florists' Club (N. Y.) will be held at Slingerlands with Fred Goldring on the evening of July 2.

About forty members of the Rhode Island Horticultural Society spent June 11 at the Arnold Arboretum and among the parks of Boston, making the day instructive as well as enjoyable.

A special rose night was observed by the New Jersey Floricultural Society at their rooms in Orange, N. J., upon the thirteenth instant when the usual run of blooms of the queen of flowers was displayed. In addition, delphiniums, peonies and dianthus were skillfully introduced, producing a greater variety of color. The honors of the evening were bestowed upon a specimen *Cattleya gigas* exhibited by Joseph A. Manda which had ten phenomenal blooms upon one stem and which was suitably rewarded by the society's first class certificate.

A very fine plan of the cities of Minneapolis and St. Paul, Minn., showing the present park system and contemplated extensions has been expressly prepared and printed for the convention of the American Society of Park

A Philadelphia Opportunity

Lease, Good Will, Fixtures and Decorating Properties

== FOR SALE ==

Old established business. Receiver will accept best immediate offer to settle up the estate. Lease extends to January 1, 1909.

An excellent opportunity for anyone wishing to start in the Florist business. ESTABLISHED 30 YEARS.

For further particulars apply to **DAVID RUST, Receiver.**

WILLIAM GRAHAM CO.

Florists... 104 South 13th St., PHILADELPHIA

Superintendents, by Messrs. Theodore Wirth and Fred. Nussbaumer, superintendents of the parks of Minneapolis and St. Paul respectively. In Minneapolis the present parks comprise 1926.43 acres and there are under consideration for extension 1150 acres. St. Paul has now 1101.54 acres and extensions proposed amount to 140 acres. These figures are exclusive of parkways and boulevards.

NEP. WHITMANI

2 1/4 in., \$5.00 per 100

NEP. WHITMANI

3 1/2 in., \$25.00 per 100

BOSTON FERNS

2 1/4 in., \$3.00 per 100

H. H. BARROWS & SON Whitman, Mass.

NEPHROLEPIS SCOTTII

in the following sizes, extra good value

25c., 50c., 75c., and \$1

Grand Specimen Plants at \$3, \$4, \$5, \$6.

JOHN SCOTT

Rutland Road and E. 45th St.

Tel. 2890 Bedford **BROOKLYN, N. Y.**

ROSES

Well rooted 3 in., ready for shipment—

Uncle John, Chatenay, Golden Gate, Ivory Bridesmaid and Bride

\$4.00 per 100, \$35.00 per 1000.

Dracaena indivisa, finethrifty stock in \$5.00 per 100. Special price by the 1000.

Hydrangea Otaksa, 2 1/2 in. \$2.50 per 100, \$21.00 per 1000.

Vinca variegata, heavy, splendid color, 1 in. \$6.00 per 100, 4 in. \$10.00 per 100.

JOHN C. HATCHER AMSTERDAM, N. Y.

Stores Amsterdam and Green-Town of Florida
 Schenectady houses and Hoffmans

Prices quoted in these columns are Advertisers Please Mention HORTICULTURE for Dealers Only. When writing to CULTURE.

PARIS SPRING SHOW



PARTIAL VIEW IN THE FIRST LARGE GREENHOUSE

Of all months in the year, May is decidedly one of the most enjoyable for a short visit to the French capital. The trees on the boulevards are clothed with their new foliage, the open spaces and gardens are planted with flowers, the air is cool and fresh. We left London on a balmy day in May, to arrive in Paris, where the weather was, with the exception of one wet afternoon, all that could be desired, to view the great annual spring show organized under the auspices of the National Horticultural Society of France, which was opened on the 22nd of the month, and lasted till the 29th, a contrast to our own famous Temple Show, which is never open to the public for more than three days.

The two large greenhouses on the Cours de Reine, which formed part of the International Exposition of 1900, are still standing, and form an admirable site, although we regret to record that after the next Chrysanthemum Show in November, they will be demolished. We can only hope that some new building equally advantageous for these splendid flower shows will be erected to replace the existing spacious glass structures, and that the society will thus be able to continue its useful work in the practical illustration of all that is choicest and best in French horticulture.

Bearing in mind the immense throngs of visitors that crowd into the place after luncheon and there remain during the whole of the afternoon and evening we decide in the interest of our American readers to make an early morning visit. Entering by the gateway near the Alexander bridge we proceed along the promenade which forms so great a feature. Let us at once say that our French friends are ever inventive, fresh and artistic in their arrangement here as elsewhere throughout the show. No two shows are ever arranged alike. Here and there are groups of shrubs, beds of hardy plants in full flower, trained fruit trees, and innumerable exhibits of garden tools, pottery, greenhouses, statuary and horticultural accessories.

We enter the doors of the first large greenhouse and a dazzling blaze of brilliant coloring meets the gaze. The accompanying illustration is a partial view and shows in the foreground zonal pelargoniums, in the middle of the square Begonia Gloire de Lorraine and around it the single and double flowering begonias and gloxinias, a little further to the rear and towards the middle a fine group of hydrangeas. These and the large exhibit of Gloire de Lorraine together with an orchid exhibit were all staged by M. Robert Leboucq, to whom was awarded the grand prix d'honneur offered by the President of the French Republic.

Before we deal with the roses, which are staged in great numbers, just before we reach the portion of the exhibition shown in our illustration we admire a choice little lot of clematis from a well-known specialist, Mr. George Boucher. Marcel Moser, Daniel Deronda, Fairy Queen, La France, William Kennett, Nelly Moser are some of the most effective. Turning now to the queen of flowers, there are many lots, but we can only deal briefly with a few of them. A fine lot is that of Messrs. Leveque et fils, many of them grown as standards. We noted among others some grand blooms of Frau Karl Duschki and Mildred Grant. Among the polyantha exhibits, of which there was also a considerable number, Mme. Nohet Levassieur, Mrs. Cutbush and Maman Levassieur were excellent.

M. Geo. Boucher also staged roses in large numbers, standards in great variety, and among other exhibits mention should be made of M. Ad. Rothberg, who had a continuous display of standards the whole length of one side of the first large greenhouse. M. Aug. Nonin was also a prominent exhibitor, some good examples of Dorothy Perkins, Blush Rambler, Stella Hiawatha, Wedding Bells, and Robert Levassieur. Among other important exhibitors we must not forget M. Defresne, who also staged a good exhibit.

We now come to a most brilliant display of zonal pelargoniums. In France

ORCHIDS

GROWING ON THE ROAD

Just to hand, a beautiful lot of

CATTLEYA MOSSIAE, C. GASKELLIANA and C. SPECIOSISSIMA

Every one of which has many new growths and which we offer at **Special Sale for 15 Days** at \$35 00 per case, each containing 45 bulbs. Come and see them and you will then believe that we quote the lowest prices in America.

C. GIGAS AND OTHERS EXPECTED SOON.

ORDONEZ BROS., - Madison, N. J.

these are not displayed in cut blooms on tables, but as pot plants arranged with considerable skill for effect and in beds of great extent, as will be seen in the right hand corner of our picture. Three beds arranged on the ground floor were set up in masses each color by itself, by M. E. Poirier. The trusses were all of large size, but the individual pips were hardly equal to some of our English growers' standard. The same exhibitor also staged a number of standard zonals, mostly varieties not known on our side of the channel. M. Andre Charmet exhibited a pink semi-double called Dagata. A very dwarf double pink Zonal called Ville de Gardes was staged in large numbers by M. Paul Feron. M. Barillet showed fancy pelargoniums in variety.

A few paces further on bring us to the hollow square, where are displayed the begonias and gloxinias. On the left hand is M. A. Billad, who staged a very effective lot of tuberous begonias. M. E. Cappe had a lovely little bed of foliage begonias with maiden hair ferns intermingled in the most artistic style. Messrs. Valierand staged gloxinias edged with begonias in great variety. In M. Lebaudy's display of Lorraines huge pots were raised at intervals over smaller pots equally well flowered, which exhibit is very plainly visible in the middle of the square in our picture.

To the right and left are two rooms specially devoted to orchid exhibits, the productions of such well-known growers as M. C. Beranek, M. R. Lebaudy, M. A. Regnier, Messrs. Ch. Maron et fils, M. Le Sueur. Hydrangeas were in several cases prominent features. M. Desire Kamelet set up a large number of Thomas Hogg in front of a background of Japanese maples--a tastefully arranged display.

Cannas, azaleas, Iris Kaempferi, carnations, etc., were shown here in great variety, also the dinner table decorations and other floral compositions from the famous house of Lachaume.

In the corridor connecting this with the second house rhododendrons and azaleas fill up two large squares, and are a sight not easily forgotten. Well grown plants of both covered with bloom are staged by Messrs. Croux et fils. There was also a very large show of these handsome plants by Messrs. Moser & Son. Messrs. Vilmorin, Andrieux & Co. had a charmingly arranged water garden and rockery, an attraction of uncommon interest for

ORCHIDS

We beg to announce the following fresh arrivals of Orchids all in finest condition.

CATTLEYA DOWJANA. Of this fine rare, and beautiful orchid we have a splendid shipment to hand.

CATTLEYA LABIATA. This is the third and last lot this season.

CATTLEYA TRIANE. The second lot to arrive in perfect condition.

CATTLEYA PERCIVALIANA in perfect shape.

CATTLEYA GASKELLIANA in best of condition, and

CATTLEYA MOSSIE.

Also Dendrobiums such as **D. THYRSIFLORUM, D. FORMOSUM, YANDA COERULEA, ONCIDIUM SPLENDIDUM,** etc., etc.

Write us for prices and we can assure you that you will be well pleased both as to quality of plants and price of same.

We also have a full line of supplies such as peat, live sphagnum and orchid baskets in all sizes.

LAGER & HURRELL, Summit, N. J.

the visitors. They also set up numerous large beds of hardy flowers in the space adjoining, the varieties being so numerous that any attempt at enumeration is an impossibility.

We are now in the second large greenhouse, and behold a sight equally as brilliant as that in the first. M. Ferard staged a large number of hardy flowers on beds. M. Brochet showed clematis, azaleas, syringas and peonies. Messrs. Angel showed tulips and anemones; M. Falaisi, pansies. A pretty lot of Primula obconica came from M. Tober Maxime. Cayeux et Leclere had hardy plants, also a pretty group of Impatiens Oliveri, bougainvilleas, kalanchoes, etc. A new double anthemis called Perfection came from M. Aubert Maille and was largely shown. M. Dessert had peonies in over 100 varieties, and many other exhibitors figured to advantage. A handsome exhibit of roses and carnations was set up on a rectangular grass lawn by M. Geo. Truffaut, grown by the aid of his famous Biogine chemical manure. Ornamental foliage plants formed

ORCHIDS

Arrived in fine condition, C. Mossiae, C. Percivaliana, C. Trianae, C. labiata, C. gigas Sanderiana, C. Harrisonia, C. Schroderae, C. citrina Den. Formosum giganteum, D. Wardianum, D. Findleyanum, Oncidium Varicosum Rogersii, O. Tigrinum, O. Ornithocheilum, Laelia anceps. To arrive shortly, Vanda Coerulea, Cattleya Gaspelliana, C. Mendellii, Phalaenopsis Amabilis, P. Schilleriana.

CARRILLO & BALDWIN, Secaucus, N.J.

ORCHIDS

Arrived in Grand Condition

CATTLEYA AMETHYSTOGLOSSA true
CATT. BOWRINGIANA
LAELIA GRANDIS TENEBROSA
ONCIDIUM SARCODES

Write for Prices

To arrive shortly

Laelia purpurata, Laelia Boothiana
(lobata), **Oncidium varicosum** Rogersii.

JOSEPH A. MANDA

191 Valley Road WEST ORANGE, N. J.

ORCHIDS

Largest Importers, Exporters, Growers and Hybridists in the World

Sander, St. Albans, England
and 235 Broadway, Room 1
NEW YORK CITY

IMPORTED ORCHIDS

Arrived in Superb Condition

Vanda coerulea, Cattleya Trianae, Cattleya gigas Sanderiana, Cattleya Schroederiae, Oncidium varicosum.

JULIUS ROEHRS CO., Rutherford, N. J.

You will find something worth reading on every page of HORTICULTURE.

Tobacco Paper IS THE **STRONGEST, BEST PACKED, EASIEST APPLIED.**

“NICO-FUME” LIQUID
OVER 40% NICOTINE
By far the **CHEAPEST.**

Furnishes the Most Nicotine for the Money!

... Manufactured by ...
THE KENTUCKY TOBACCO PRODUCT CO., Louisville, Ky.

JUST NOTE PRICES!

24 sheets.....	\$ 0.75
144 sheets.....	3.50
288 sheets.....	6.50
1728 sheets.....	35.10

Pint.....	\$ 1.50
½ Gallon.....	5.50
Gallon.....	10.50
5 Gallons.....	47.25

an unimportant feature of the show and we must not forget to mention that M. Chabrier showed crotons, caladiums, calatheas, etc., in a well set-up group which included a hybrid vriesia between Tillandsia tessalata and Vriesia fenestralis. Two fine groups of dracaenas and other decorative plants were staged by M. Emile Morel. Messrs. Cordonnier et fils also staged crotons in variety.

Vegetables in enormous quantities were shown by Messrs. Vilmorin Andrieux & Co., as is usual for that eminent firm on such occasions. Another local exhibitor was the Societe Mutuelle des Jardiniers et Horticulteurs, who also put up a very fine lot. Fruit was of a high quality generally. Some of the best growers participated. Graperies de Somain, neatly arranged their grapes in baskets, Frankenthal, Foster's Seedling, Black Alicante and Gros Colman. Another exhibitor of grapes was M. Alb. Mercier. The Forceries de la Seine showed peaches and nectarines and Messrs. A. Cordonnier et fils also staged a handsome lot of peaches, nectarines, plums and grapes—an imposing display set up in handsome glass cases.

An art gallery consisting of over 400 pictures of fruit and flowers was at the far end of the show and was a fine collection in oil and water colors. A special catalogue of this was provided. Altogether the schedule of the show comprised 370 classes, so that our readers will see the impracticability of attempting to give anything like a detailed account of every exhibitor's lot.
C. HARMAN PAYNE.

MOVEMENTS OF GARDENERS.

Robert Stobo, assistant gardener on the Constable estate, Mamaroneck, has taken a position as superintendent of the Gilbert estate, Great Neck, L. I., New York.

STERILIZED

Sheep Manure to help out backward vegetation, 100 lbs. \$1.50.

W.M. ELLIOTT & SONS
42 Vesey Street, New York



Cattle Manure In Bags Shredded or Pulverized

Best and safest manure for florists and greenhouse use, absolutely pure, no waste, no danger. Write for circulars and prices.
The Pulverized Manure Co.,
31 Union Stock Yards, Chicago

During Recess

The Florists' and Gardeners' Club of Rhode Island to the number of twenty visited the Rhode Island Hospital on invitation of Brother Cornelius Harts-tra and Dr. J. M. Peters as alternate, on June 15. The grounds were gone over and very favorable comments made on the beautiful arrangement of the border beds, etc., and a turn through the greenhouses which were a model of neatness. The party was then turned over to Mr. McLaughlin, janitor of the institution, who gave us an idea of the ground floor work in an able manner.

We were then introduced to a genial guide, Eugene W. Amos, chief engineer of the establishment, who conducted the party through the several wards and apartments. Upon our descent we were introduced to Dr. J. M. Peters who received the party in a very "hospital" manner. In the reception room a most substantial lunch was served after which remarks were made by Secretary Chappell and responded to by Dr. Peters.

Later in the evening the club held their meeting, and added two new members to the roll of honor, after which Messrs. James Hockey and James J. Barclay furnished a very pleasant musical entertainment. Our club seems to be on the pick up. Several new members have been added of late and a number have been reinstated. Our meetings are well attended and we are looking forward to a very good interest this fall. Meetings will be discontinued through July and August.
WM. E. CHAPPELL, Sec'y.

LIST OF PATENTS.

- 887,275. Weed Cutting and Root Destroying Device. Julius Rumpel, Weston Mo.
- 887,359. Manure Spreader. Henry Synck, Maria Stein, Ohio.
- 887,445. Onion Cleaner and Sorter. Samuel S. Wagner, Lodi, Ohio.
- 887,461. Topper Attachment for Lawn Mowers. John W. Card, Dryden, N. Y.

CATALOGUES RECEIVED.

Henry Meite, Quedlinburg, Germany. Colored plate of Giant-flowered and Fancy Pansies. Very handsome.

BATH.—B. C. Clark, of Wheeler, agent for a nursery house in Newark, N. J., was arrested on a charge of grand larceny in this place.—Elmira, N. Y., Gazette.

DON'T EXPERIMENT

USE **To-BAK-INE**

and your stock will be free from insects, clean, and the blooms will not be discolored.

Send for full information of

H. E. FISKE SEED CO.
13 Faneuil Hall Sq., Boston, Mass.

STUMPP & WALTER CO.,
50 Barclay St., New York.

HENRY F. MICHELL & CO.,
1018 Market St., Philadelphia.

E. H. HUNT, Gen'l Agent,
76-78 Wabash Ave., Chicago.



The Best Bug Killer and Bloom Saver

For PROOF Write to

P. R. Palethorpe Co.
OWENSBORO, KY.

JAGER SPRAYERS

are money makers and money savers because they enable you to do the work right, with little labor and without wasting solution. We make an outfit for every need, from large Power Sprayers to small Hand Sprayers—each the best of its kind. **Special Sprayer Book Free.** Illustrating and describing our complete line. Investigation pays.
Chas. J. Jager Co., 241-3 Franklin St., Boston, Mass.
Branch: 33 Canal St., Providence, R. I.

Seed Trade

The following members have just been appointed by the President of the New York Produce Exchange to serve on the Committee on Seeds for the ensuing year: Wm. Jacot, Marshall H. Duyea, Ernest Wehncke, O. W. R. Randolph, Chas. Wimmer.

Des Moines, Ia., Jun. 9.—Iowa seed dealers in session here today are of the opinion that, though the pure seed law enacted in the last general assembly is a step in the right direction, several changes should be made in it. State Commissioner Wright appeared before the convention and answered questions asked by the dealers and in general agreed with them on the needed amendments. The chief objection to the law, as it now stands, is that there is no provision for prosecuting the small dealers who receive seeds marked "to be cleaned" and, removing these tags, sell them. Professor L. H. Pammel of Ames, one of the framers of the law, agreed that he had noticed the defects during the year it had been tested and realized that remedies are needed. He suggested a state commission to get a standard for seeds and that it be made to include vegetable and flower seeds. Professor Holden and Professor Crossley of Ames also spoke.—Council Bluffs Nonpareil.

INCORPORATED.

Olga Orchard Co., Athens, Tex.; E. L. Maymon, A. B. Mandelstamm, E. Y. Brady; capital, \$15,000.

The Cedaredge Orchard Co., Denver, Colo.; E. D. Ewing, C. H. Pugh, C. E. Chadsey; capital, \$50,000.

The Washington Park Floral Co., Denver, Colo.; J. C. Buckman, F. A. Buckman, N. Anderson; capital, \$25,000.

The Miller Floral Company, Salt Lake City, has been incorporated in Delaware with a capital stock of \$100,000.

The Stella Planting Co., New Orleans, La.; J. B. Sinnott, C. J. Sinnott, H. L. Sinnott, W. L. Saxon, P. J. Orchard; capital, \$75,000.

SWEET PEAS

FOR FORCING

To grow Flowers for Thanksgiving sow in July

CHRISTMAS PINK
CHRISTMAS WHITE

25c per oz. 1-4 lb. 75c.
\$2.00 per pound.

MICHELL 1018 MARKET ST.
PHILA., PA.

PRIMROSE SEED

IMPROVED CHINESE

Finest grown large flowering, fringed, single and double, 15 varieties, mixed, 500 seeds, \$1.00; half pkt., 50c. Have the varieties separate, also.

JOHN F. RUPP, Shiremanstown, Pa
THE HOME OF PRIMROSES.

SWEET PEAS

For THANKSGIVING and CHRISTMAS

BODDINGTON'S CHRISTMAS WHITE.....	Oz.	1/2 lb.	1 lb.	Lb.
" " PINK.....	10c	40c	60c	\$1.00
" " SNOWBIRD, the earliest forcing white ..	10c	40c	60c	1.00
FLORENCE DENZER, (pure white)	20c	75c	1.25	2.00
WATCHUNG, (pure white)	10c	40c	60c	1.00
	20c	75c	1.25	2.00

Also other varieties as advertised prices. All the above mailed free.

PANSY—BODDINGTON'S "CHALLENGE." This mixture contains all the finest giant strains of the leading Pansy Specialists in the world—the Giant self-colors, the Giant striped and margined, and the Giant blotched—all carefully mixed in proportion. Tr. pkt. 75c., 1/4 oz. \$1.50. 1/2 oz. \$2.75; oz. \$5.00.

ARTHUR T. BODDINGTON, Seedsman
342 West 14th Street, - NEW YORK CITY

ASTER GROWERS ATTENTION:

Our Seed is All Sold. If you failed to get some it is your loss. However:— Get a Competition Card Now, Enter your name as an Aster Grower of America and win part of our \$250.00 offered in prizes. Entry free. All information gladly given. No cost to you except to prepay the express charges on flowers sent in competition.

Altimo Culture Co., Canfield, Ohio.



THORBURN'S BULBS

LILIUM HARRISII, 5-7 in.	100	1000
7-9 "	\$4.50	\$40.00
	8.50	80.00

Send for advance prices on Holland Bulbs, Japan Lilies and Roman Hyacinths.

ASPARAGUS PLUMOSUS ROBUSTUS,
\$2 00 per 1000 seeds.

Pansy, Carnation, Daisy and all other seeds for florists.
Cold Storage Lily of the Valley Pips

J. M. THORBURN & CO.
33 Barclay St., through to 38 Park Place
NEW YORK

Best Quality Fall Bulbs

It is to your advantage to place your order early. Send us a list of your wants and we will quote you rock-bottom prices. Copy of our Florists' Bulb Catalogue will be sent upon request. Catalogues now ready.

VICK'S SUPERB PANSY SEED

All the best varieties in separate colors

VICK'S SUPERB MIXTURE

the best strain from all the leading named sorts
1-8 oz. 75c. 1-4 oz. \$1.50 Ounce \$5.00

JAMES VICK'S SONS, Rochester, N. Y.

PRIMULA, FRINGED SINENSIS

This seed has been grown for us by a specialist in the culture of Primula, and he has produced plants of sturdy growth, large, thick flowers beautifully fringed and carried on erect stems well above the foliage; unexcelled in size, substance and beautiful colors.

Giant Pe section strain, Finest Mixed, 1-64 oz., \$1.00
Pure White, Brilliant Pink, Blue, Chiswick Red, and
Crimson, 1-64 oz., \$1.00.

H. E. FISKE SEED CO.
13 Faneuil Hall Sq., BOSTON, MASS.

CABBAGE SEED

HJALMAR HARTMANN & CO.,
12 Stormgade,
COPENHAGEN, DENMARK.

SOW NOW MY STRAIN OF Hardy Garden Carnations as:

Special Mixture of extra double flowers.....	Per	Tr.
Dwarf Scarlet Grenadin.....	Oz.	Pkt.
Early Dwarf Vienna, finest mixed.....	2.50	.30
New Early White Vienna, fine for cutting.....	2.00	.30
New Early Dwarf Hardy Garden Pinks, in splendid colors, mixed.....	1.50	.20
	4.20	.50

O. V. ZANGEN Seedsman Hoboken N. J.

JUST ARRIVED LARGE SHIPMENT OF High-Grade SCOTCH SOOT.

We have the Stott Double Nozzle
THOMAS J. GREY CO.
32 & 33 So. Market St., BOSTON

BRIDGEMAN'S SEED WAREHOUSE RICKARDS BROS. Props.

37 East 19th St., - NEW YORK CITY
BRASLAN SEED GROWERS CO.

GROWERS FOR THE WHOLESALE TRADE ONLY

SAN JOSE, - - CALIFORNIA

BRECK'S SEEDS
For Farmer, Market Gardener and Florist
New Crop High Grade
Catalogues mailed free on application

Joseph Breck & Sons Corp.
47-54 NO. MARKET ST., BOSTON, MASS.

Winter-flowering SWEET PEA SEED

All Colors
New crop ready in August next. Ask for list.

A. C. ZVOLANEK
ORIGINATOR BOUND BROOK, N. J.

Burpee's Seeds

PHILADELPHIA

Blue List of Wholesale Prices mailed only to those who plant for profit.

**JOHN BREITMEYER'S
SONS**

Cor. Miami and Gratiot Aves.
DETROIT, MICH.

**Artistic Designs . . .
High Grade Cut Blooms**

We cover all Michigan points and good sections of Ohio, Indiana and Canada

**William J. Smyth
FLORIST**

Cor. Michigan Ave. and 31st St., CHICAGO

We ship to all points in Illinois and Iowa.

Phones: Douglas 744, Douglas 523, Douglas 740

M. C. and J. E. HAUSWIRTH

**232 Michigan Ave.
CHICAGO**

AUDITORIUM ANNEX Tel. Harrison 585

**SAMUEL MURRAY
Florist**

Coates House Conservatory
1017 BROADWAY, KANSAS CITY, MO

Both 'Phones 2670 Mafa

**FRED C. WEBER
FLORIST**

4326-28 ST. LOUIS, MO.
OLIVE STREET

Established 1873
Long Distance Phone Bell Lindell 676



WASHINGTON,
D. C.

GUDE'S

The Far-Famed Flowers of
TORONTO

Delivered on mail or telegraph order for any occasion, in any part of the Dominion.

JOHN H. DUNLOP,
96 Yonge St., Toronto. Ont.

The Park Floral Co.

J. A. VALENTINE
Pres.

DENVER, COLORADO

**WILLIAM L. ROCK
FLOWER CO.**

KANSAS CITY, MO.

will carefully execute orders for Kansas City and any town in Missouri or Kansas.

Of Interest to Retail Florists.

The florists of Holyoke, Mass., report that in spite of dull times there has been no let-up in their business. In fact the trade this spring in many instances has passed the best previous years.

Paul Blome & Co. of 554 N. Clark street, Chicago, have now a fine retail store and conservatories in the rear which have been built during the past season. Mr. Blome reports weddings not quite so numerous as in more prosperous years. The leaving of so many Chicago people for their summer homes is making quite a difference in the volume of trade.

STEAMER DEPARTURES

Allan.

Corsican, Montreal-Liv'p'l.	June 21
Virginian, Montreal-Liv'p'l.	July 3
Anchor.	
Caledonia, N. Y.-Glasgow.	June 27
Columbia, N. Y.-Glasgow.	July 4
American.	
Phila., N. Y.-Southampton.	June 27
St. Paul, N. Y.-Southampton.	July 4
Atlantic Transport.	
Minnehaha, N. Y.-London.	June 27
Minneapolis, N. Y.-London.	July 4
Cunard.	
Mauritania, N. Y.-Liv'p'l.	June 24
Carmania, N. Y.-Liv'p'l.	June 27
Campania, N. Y.-Liv'p'l.	July 1
Etruria, N. Y.-Liv'p'l.	July 4
Saxonia, Boston-Liv'p'l.	June 30
French Line.	
La Provence, N. Y.-Havre.	June 25
La Lorraine, N. Y.-Havre.	July 2
Hamburg-American.	
Deutschland, N. Y.-Hamb'g.	June 25
Patricia, N. Y.-Hamburg.	June 27
Holland-American.	
Noordam, N. Y.-Rotterdam.	June 24
Rotterdam, N. Y.-Rotterdam.	July 1
North German Lloyd.	
Kais. Wm. II., N. Y.-Brem.	June 23
Kaiser Wm. de Grosse, New York-Bremen.	June 30
Red Star.	
Kronland, N. Y.-Antwerp.	June 27
Finland, N. Y.-Antwerp.	July 4
White Star.	
Majestic, N. Y.-Soh'mton.	June 24
Arctic, N. Y.-Liverpool.	June 25
Oceanic, N. Y.-Soh'mton.	July 1
Celtic, N. Y.-Liverpool.	July 2
Republic, Boston-Liverpool.	July 4

At the banquet of the National Republican Committee at the Auditorium in Chicago on the 8th of June in honor of C. E. Dawes the decorations by Hauswirth were beautiful and unique. Down through the center of the spacious dining hall was an oblong plot or carpet of green moss fifty feet long and about eight feet wide, edged with geraniums and having palms scattered in the center. Around this were the tables and outside of the tables were placed bay trees at intervals interspersed with magnificent bouquets of peonies and roses. The tables themselves were decorated with asparagus plumosa.

NEW RETAIL FLOWER STORE.
Mrs. J. Sangster, Buffalo, N. Y.

Chicago.

Established in 1857



1657-1659 Buckingham Place

L. O. Phone 558 Lake View. Send us your retail orders.

We have the best facilities in the city.

ALEX. McCONNELL

571 FIFTH AVENUE
NEW YORK CITY

Telegraphic orders forwarded to any part of the United States, Canada, and all principal cities of Europe. Orders transferred or intrusted by the trade to our selection for delivery on steamships or elsewhere receive special attention.

Telephone Calls, 487 and 488 38th St.
Cable Address, ALEXCONNELL

DAVID CLARKE'S SONS

Deliver orders from any part of the country to
New York City
Or **OUT-GOING STEAMERS**
Write or telegraph
2139-2141 Broadway, New York
Telephone 1552-1553 Columbus

YOUNG & NUGENT

42 West 28 St., NEW YORK
"FLOWERS BY TELEGRAPH"

Flower Deliveries

In Brooklyn and other Long Island Points New York City, New Jersey, etc. At Theatres, Hotels, Steamers or Residences.

WILSON

Fulton St. and Greene Ave., Brooklyn, N. Y.
ALBANY, N. Y.

EYRES

Flowers or Design Work

DELIVERED IN ALBANY AND VICINITY ON TELEGRAPHIC ORDER.

11 NORTH PEARL ST., ALBANY, N. Y.

YALE

Orders for flower deliveries to Yale College and all other Connecticut points carefully filled and delivered by
J. N. CHAMPION & COMPANY
1026 CHAPEL STREET NEW HAVEN, CONN.

JACOB SCHULZ, 644 Fourth Ave., LOUISVILLE, KY.
Cut Flowers of BEST QUALITY in season delivered promptly to any address.
Write, Telegraph or Telephone.
Cumberland and Home Phones 223 and 984

ATLANTA FLORAL CO.

41 Peachtree Street, ATLANTA, GEORGIA.

In ordering goods please add "I saw it in HORTICULTURE."

Obituary

Lawrence Lundberg.

A sad accident occurred on June 10th in which Lawrence Lundberg, a florist, at 616 Wells street, Chicago, lost his life. Mr. Lundberg was driving with a friend and the buggy was struck by a North avenue car, Mr. Lundberg was thrown out and never recovered consciousness.



LAWRENCE LUNDBERG.

Lawrence Lundberg was born in Sweder twenty-nine years ago, where he remained till six years ago, learning the florist's business in his native country. He had a fine retail store and was doing well. During the three years since he started he has built up a nice trade and his florist friends deeply regret his untimely death. He leaves a wife and little daughter two years of age. Mrs. Lundberg will continue the business.

A. David Rose.

A. David Rose, formerly of Ballin-



A. DAVID ROSE.

dalloch Castle, died on June 16 at his home in Montclair, N. J., after a long

illness. The funeral on Thursday, June 18, was attended by many sorrowing friends in the florist and garden fraternity, for "Davy" Rose was beloved by everybody who knew him and sympathy most sincere has gone out to him during the long suffering which he has faced with so much fortitude. Mr. Rose had a very wide acquaintance among the trade. He had been employed at many places of note—private and commercial—including the Gardner Brewer estate at Newport, R. I., the Pratt estate in Brooklyn, N. Y., E. G. Hill Co., Richmond, Ind., and Pitcher & Manda, Short Hills, N. J., at all of which he had acquitted himself with credit. A few years ago he went into business in Jersey City, N. J., and later moved to Montclair where he secured the old Michie place which he conducted up to the present time.

Alexander Wallace.

As we go to press a telegram advises us of the death of Alexander Wallace, editor of the Florists' Exchange, New York. Mr. Wallace has been ailing for a short time with a complication of diseases. He was out of his office for about ten days and then returned for two days, but was unable to continue and on Wednesday, June 17, he passed away. He was born in Lawrence Kirk, Kincardynshire, Scotland, on November 21, 1859. He came to this country in 1888 and one year later entered the employ of the A. T. De la Mare Printing and Publishing Company, and soon assumed the editorship of the Florists' Exchange published by that company, a position for which a good education and knowledge of stenography made him well fitted. He read much and, having a good memory, was able to apply his insight into horticulture thus obtained to good advantage. One of Mr. Wallace's most striking characteristics was his thoroughness. Whatever he undertook he followed up to the minutest details, and this analytical exactness was in evidence in all his work. On committee assignments in the S. A. F. and the New York Florists' Club, in both of which organizations he was a member, his duties were always accepted cheerfully and performed faithfully. He served as a member of the Executive Board of the S. A. F. for one term of three years, having been appointed by President Patrick O'Mara. We extend to our esteemed contemporary our sincere sympathy in the great loss which they and the cause of horticulture have sustained.

The funeral will be at Church Green and Washington avenues, Brooklyn, N. Y., on Saturday, June 20. Interment at Greenwood.

Ira L. Russell.

Ira L. Russell, market gardener of Arlington, Mass., died on June 12 at the age of 74.

William Barr.

William Barr died at Lewellyn Park, Orange, N. J., on June 16, aged 81 years.

William Graham has leased the Mergenthaler place at East Washington Lane, Germantown, Pa. Dr. Burrows is associated in this new venture.

PROMPT DELIVERY IN BOSTON

AND ALL NEW ENGLAND POINTS
HOUGHTON & CLARK
396 Boylston St., Boston, Mass.



BOSTON'S BEST

In Quality and Design

Can be relied upon when you transfer your retail orders to

EDWARD MACMULKIN

194 Boylston Street, Boston

Send flower orders for delivery in

BOSTON

and all

NEW ENGLAND POINTS

THOS. F. GALVIN

124 Tremont St., Boston

TRANSFER

Your orders for flower or plant delivery in Eastern New England to

JULIUS A. ZINN,

2 Beacon St., Boston.

Fine Design Work a Specialty.

Baskets Made to Order FOR FLORISTS

I have the most skilled Tribe of Pottowattomic Indian basket makers in the world ready to make any thing in the shape of florists' baskets at low prices. Be Original—have your baskets made to order in your own styles.

E. H. HITCHCOCK, GLENWOOD, MICH.

Wired Toothpicks

Manufactured by

W. J. COWEE, BERLIN, N. Y.

10,000....\$1.75; 50,000....\$7.50. Sample free.
For sale by dealers

WEIGEL & UJFALUSSY

Successors to Emil Steffens

Manufacturers of Florists' Wire Designs and Supplies. Established 1866.

136-138 W. 28th St., New York City
Telephone 1922 Madison Sq.

Anything in the line of wire work and designs not listed in our catalog will be made up promptly on short notice.

"QUICK WORK, BUT O. K."

HORTICULTURE, Boston, Mass.:

Dear Sirs:—Kindly cancel our advertisement on Gardenias as we have secured all we want in this line. Quick work but O. K. We will use your medium in future when in need of any more advertisements.

Very truly yours,

KNIGHT & STRUCK.

New York, June 15, 1908.

ROSE PLANTS

Ready for Delivery.

2000 Brides, 3 1/2 in. pots	\$6.00	\$50.00
2500 Brides, 2 in. "	3 00	25.00
2000 Richmond, 2 1/2 in. pots	5.00	45.00
2000 Killarney, 3 in. pots	8.00	

We guarantee plants to give satisfaction.

The Leo Niessen Company

1209 Arch St., Philadelphia, Pa.
Open from 7 a. m. to 8 p. m.

Everything
in
Flowers.



Everything
in
Florist's
Supplies.

When You See This Label, Quality Is Guaranteed.

S. S. PENNOCK - MEEHAN CO.

1608-1620 Ludlow St. PHILADELPHIA
"The" Wholesale Florists of Philadelphia

EVERYTHING SEASONABLE IN
CUT FLOWERS

EDWARD REID, Wholesale Florist

1526 Ranstead St., PHILADELPHIA
STORE CLOSES 8 P. M.

CHAS. W. MCKELLAR

51 WABASH AVE., CHICAGO

Western Headquarters for Choice Orchids
Valley, Roses and all Cut Flowers

PETER REINBERG

WHOLESALE
CUT FLOWERS

51 Wabash Av., Chicago, Ill.

CUT FLOWER BOXES
EDWARDS FOLDING BOX CO
MANUFACTURERS
PHILADELPHIA, PA.

AMERICAN BEAUTY and all other ROSES

LILY OF THE VALLEY, CARNATIONS
WELCH BROS., 226 Devonshire St., Boston, Mass.

New Crop Dagger Ferns

\$2.00 per 1000
Case lots of 10 P. at \$1.50 per 1000

W. E. MCKISSICK WHOLESALE FLORIST
PHILADELPHIA
1619-1621 RANSTEAD ST.

DAILY CONSIGNMENTS

From 40 to 60 Growers
We can care for your cutflower wants to advantage.

E. F. WINTERSON CO.
45-47-49 WABASH AVE., CHICAGO

Rice Brothers

115 N. 6th Street, MINNEAPOLIS, MINN.
WHOLESALE FLORISTS and SUPPLIES

* CUT FLOWERS received twice daily, and can fill your orders to your satisfaction. A complete line of Hardy Greens — WILD SMILAX, BOXWOOD, HARDY FANCY FERNS, GALAX LEAVES.

Write for quotations on large quantities.

E. A. BEAVEN

Southern Wild Smilax,
Log Mosses,
Natural and Perpetuated — at Wholesale
EVERGREEN, ALABAMA.

TOWER HOTEL

Niagara Falls, N. Y.
is soliciting your patronage during the
S. A. F. Convention.
Very truly yours,
M. J. HOENIG, Prop.

WHOLESALE FLOWER MARKETS—TRADE PRICES—Per 100 TO DEALERS ONLY

	CHICAGO June 16	TWIN CITIES June 16	PHILA. June 15	BOSTON June 18
ROSES				
Am. Beauty, Fancy and Special...	25.00 to 35.00	25.00 to 30.00	20.00 to 25.00	15.00 to 20.00
" Extra.....	20.00 to 25.00	15.00 to 22.00	10.00 to 15.00	12.00 to 15.00
" No. 1.....	18.00 to 20.00	10.00 to 12.00	6.00 to 8.00	6.00 to 10.00
" Lower grades.....	6.00 to 10.00	6.00 to 8.00	3.00 to 5.00	1.00 to 4.00
Bride, 'Maid, Fancy & Special.....	4.00 to 6.00	6.00 to 8.00	5.00 to 6.00	4.00 to 6.00
" Lower grades.....	2.00 to 4.00	2.00 to 5.00	2.00 to 4.00	.50 to 1.00
Killarney, Richmond, Fan, & Sp.....	8.00 to 10.00	8.00 to 10.00	5.00 to 8.00	4.00 to 6.00
" Lower grades.....	4.00 to 6.00	5.00 to 7.00	2.00 to 3.00	.50 to 4.00
Chateau, Fancy and Special.....	6.00 to 8.00	5.00 to 8.00	5.00 to 6.00	4.00 to 6.00
" Lower grades.....	4.00 to 6.00	3.00 to 5.00	1.00 to 4.00	.50 to 3.00
Kaiserin, Carnot.....	6.00 to 8.00	6.00 to 8.00	4.00 to 8.00	.50 to 6.00
Golden Gate, Ivory.....	4.00 to 6.00	6.00 to 8.00	2.00 to 8.00	.50 to 4.00
CARNATIONS				
Fancy and Novelties.....	1.00 to 2.00	2.50 to 3.00	2.00 to 3.00	1.00 to 2.00
Ordinary.....	.75 to 1.00	1.50 to 2.00	1.00 to 2.00	.30 to 1.00
MISCELLANEOUS				
Cattleyas.....	40.00 to 50.00	40.00 to 50.00 to 50.00	40.00 to 50.00
Lilies.....	5.00 to 6.00	6.00 to 12.00	10.00 to 12.50	3.00 to 5.00
Lily of the Valley.....	3.00 to 4.00	3.00 to 4.00	2.00 to 4.00	1.00 to 3.00
Daisies.....	.20 to 1.00	1.00 to 2.00	.50 to 1.00	.50 to 1.00
Pansies.....	.25 to .50 to .50	.30 to .50	.25 to .50
Peonies.....	3.00 to 5.00	2.00 to 6.00	4.00 to 6.00	2.00 to 4.00
Gladioli.....	10.00 to 12.00	2.00 to 12.00	3.00 to 5.00	2.00 to 3.00
Mignonette.....	.75 to 1.50 to 1.00	1.00 to 2.00	1.00 to 2.00
Gardenias.....	25.00 to 35.00	5.00 to 15.00	15.00 to 25.00	12.00 to 25.00
Sweet Peas.....	.50 to 1.00	.75 to 1.00	.50 to .75	.15 to .50
Adiantum.....	1.00 to 1.25	1.00 to 1.25	1.00 to 1.50	1.00 to 1.50
Smilax.....	10.00 to 12.00	15.00 to 20.00	15.00 to 20.00	10.00 to 12.00
Asparagus Plumosus, strings.....	30.00 to 40.00	35.00 to 50.00 to 50.00	25.00 to 50.00
" " & Spren. (100 bchs.)	15.00 to 20.00	35.00 to 50.00	35.00 to 50.00	15.00 to 50.00

J. A. BUDLONG

37-39 Randolph Street, CHICAGO.

Roses and Carnations
A Specialty.....

ROBERT J. DYSART,
Public Accountant and Auditor

Simple methods of correct accounting especially adapted for florists' use.

Books Balanced and Adjusted

Merchants Bank Building
28 STATE ST., BOSTON
Telephone, Main 58.

WHOLESALE GROWER of

CUT FLOWERS

J. B. Murdoch & Co.
Wholesale Florists
FLORISTS' SUPPLIES
714 Penn Ave., PITTSBURG, PA.
Long Distance 'Phone 1435 Court.

H. BAYERSDORFER & CO.

Known to the Trade for the past 30 years as the

Representative Florists' Supply House of America

Always first in the market with anything that is new, novel and appropriate.

FOR THE MONTH OF WEDDINGS AND GRADUATIONS

We have prepared for your needs with a stock of desirable and useful goods, unequalled in quality and extent anywhere on this continent and at prices that cannot be beaten. Orders by mail or telegraph will be filled immediately. Catalogue on application.

H. BAYERSDORFER & CO., 1129 Arch St., Philadelphia

FLOWER MARKET REPORTS

BOSTON The flower market has picked up a little life this week, due in part to the demand and in part to the decreased supply. The wedding and graduation period is doing excellent work for the lily of the valley, the sweet pea and the American Beauty rose. Pres. Carnot and Kaiserin roses are the only roses that can boast of perfect foliage and acceptable style. The other roses show the wear and tear of the long winter campaign, and most of the carnations are in the same predicament. Prices remain stationary.

CHICAGO There has been no decided change in the Chicago cut flower market during the past week but the general tendency is in the line of improvement. The Republican convention has brought many people to the city and in various ways increased the sale of flowers. Weddings are numerous though there is a difference of opinion as to whether the number is equal to that of last year and lily of the valley is quite in demand. Sweet peas are also selling readily. In one wholesale house was noticed unusually fine *Lilium auratum*. Carnations are plentiful and bringing fair prices for good stock. Flowers are in abundance though not in excess as was the case a week ago. Some fine Canterbury Bells grown by Wittbold are in market. Peonies certainly are excellent and though the supply is very large most of them find buyers. Some very fine Shasta daisies are also seen. Trade in florists' supplies is active.

INDIANAPOLIS June trade up to the present time has more than met the approval of the majority of the florists. The June weddings and commencements as usual have used great quantities of choice stock. Sweet peas of quality had a tremendous run. Beauties, cattleyas and lily of the valley are excellent with good demand. All seasonable stock is plentiful but the quality is daily becoming more inferior. A few asters are in and gladioli are becoming more abundant. Carnations, and in fact everything in the field, is looking very promising.

NEW YORK The volume of business diminishes from week to week. There is still a glut of carnations and quality is poor with a few exceptions. Rose growers are throwing out rapidly and this helps to the extent of not having a lot of unsalable stock in sight. Beauties are moving somewhat better but prices are still low. Of the small roses, Killarney and Testout have the preference. Richmond does not amount to much. Cattleyas and lily of the valley of the best grades sell fairly well, inferior stock finding little outlet.

PHILADELPHIA Trade here for the second week in June was not up to standard. Commencements and weddings were numerous enough but much of the flower work for same was on a very modest scale and in some cases was cut out altogether. Receipts have shortened up, many of the growers having cut out the poorest houses in their roses and carnations, now that these have ceased to be remunerative, with a view to repairs and replanting. American Beauty roses are still of good quality and fairly plentiful. The first of the new crop have commenced. These are limited and come from one or two growers who planted early so as to overlap on the regular throwing-out season. Brides and Bridesmaids are poor, Kaiserin good, Liberty better than Richmond and Killarney is now coming in nice and clean. There is very little that is choice in carnations. Retarded peonies are plentiful—the local outdoor cut being over—demand good and quality excellent. Orchids less plentiful and moving better. Outdoor sweet peas have never been better; color, substance and stem perfect.

TWIN CITIES The cut flower market has been good; the supply equals the demand. American Beau-

ty, Bride, Bridesmaid and Chatenay roses are about gone and whatever is on the market is short-stemmed and of inferior quality. *Gladiolus America* and *Princeps* are selling for \$12 per 100 while the common kinds only bring from \$2 to \$4.

NOTES.

Detroit advices indicate that were it not for a few bouquets and graduation jobs matters in the floral lines would be extremely monotonous. Even as it is there is very little to do. The wholesalers are kept busy throwing out the surplus.

Washington reports that there is almost nothing doing in the flower market now, as this week winds up all of the Washington schools. It will be hard to dispose of flowers now at any price for social affairs are a matter of ancient history.

PHILADELPHIA NOTES.

Arthur T. Boddington of New York was in town recently inspecting seed store fittings.

Charles H. Meehan who has been laid up with a severe attack of quinsy for the past two weeks returned to his duties on Saturday.

Henry F. Ehrsman succeeds to the business of John Lees at Frankford avenue and Bridge street, Frankford. Mr. Lees is reported to have gone West.

"The Garden," London, announces the Garden Flower Show to be held at the Royal Horticultural Society's Hall, on Wednesday, July 29, 1908. The sum of 100 pounds (\$500) will be offered in prizes and one gold and two silver medals will be awarded. Only readers of the paper will be allowed to compete.

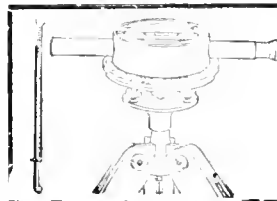

Bostrom Improved Builders' Levels and Farm Levels

For Park, Cemetery and Landscape Gardening use, take the place of expensive Engineering Instruments. Simple in construction, easily adjusted, more substantial and less cumbersome than the more elaborate and complicated instruments. Practical, up-to-date instrument that any one can use. Write for descriptive circulars and be convinced that this Level is necessary to complete your outfit. Builders' Level \$25.00. Farm Level \$12.50.

BOSTROM-BRADY MFG. CO., 139 Madison Avenue, ATLANTA, GA

FORD BROTHERS
 48 West 28th Street, NEW YORK
FINE ROSES FANCY CARNATIONS
 A Full Line of All CUT FLOWERS
 Telephone, 3870 or 3871 Madison Square

H. E. FROMENT,
 Wholesale Commission Florist,
 Choice Cut Flowers,
 57 West 28th St., :: NEW YORK.
 Telephones: 2200, 2201, Madison Square.

The Reliable Commission House
 Richmond Roses and Rich Flowers
 of all varieties
JOS. S. FENRICH
 110 W. 28th Street, New York
 Tel. 324-325 Madison Square

Alfred H. Langjahr
 All choice cut-flowers in season. Send
 for quotations. Correspondence with
 shippers of first-class stock invited.
55 West 28th Street, New York.
 Telephones 4626-4627 Madison Square

Edward C. Horan
 Wholesale Florist
 55 WEST 28th ST.
 Tel. 1462
 1463 Madison Square New York

JOHN I. RAYNOR
 Wholesale Commission Florist SELLING AGENT FOR LARGEST GROWERS
 A full line of Choice Cut Flower stock for all purposes. Comprises every variety
 grown for New York market, at current prices
 TEL. 1998 MADISON SQUARE 49 W. 28 St., New York City

Walter F. Sheridan
 Wholesale Commission Dealer in
CHOICE CUT FLOWERS
 39 West 28th Street, New York
 Telephone: 3532-3533 Madison Square

HEADQUARTERS FOR NOVELTIES
ORCHIDS A SPECIALTY
 THE HIGHEST GRADE OF **VALLEY** ALWAYS ON HAND
 GARDENIAS, DAISIES, ROSES AND CARNATIONS
 Telephone
JAMES McMANUS, 759 Mad. Sq. 42 W. 28th St., New York

PHILIP F. KESSLER 55 & 57 W. 26th St., New York City
 Commission Dealer, Wholesale Buyer
 and Seller of
CUT FLOWERS
 Open from 5 a. m. to 6 p. m. Sunday
 till 10 a. m.
 Tel., 5243 and 2921 Madison Sq. Res., 345 J., Newtown.
Finest Lilies in the Market Every Day in the Year.

WHOLESALE COMMISSION FLORIST
J. K. ALLEN 106 W. 28 ST. NEW YORK
 Telephone 167 Madison Sq.
 OPEN 6 A.M. DAILY
 We have a good regular outlet for seasonable flowers

NEW YORK QUOTATIONS PER 100—TO DEALERS ONLY

	Last Half of Week ending June 13 1908	First Half of Week beginning June 15 1908	Last Half of Week ending June 13 1908	First Half of Week beginning June 15 1908
Roses				
Am. Beauty, lae and sp.	6.00 to 15.00	6.00 to 15.00		
" extra	5.00 to 6.00	4.00 to 6.00		
" No. 1	2.00 to 4.00	2.00 to 4.00		
" Lower grades50 to 1.00	.50 to 1.00		
Bride, 'Mald, lan and sp.	3.00 to 5.00	3.00 to 5.00		
" lwr. grds.50 to 1.00	.50 to 1.00		
Killrney, Richmond, fancy & spec	3.00 to 6.00	4.00 to 5.00		
" lower grades50 to 2.00	.50 to 2.00		
Chatenay, Fancy and Special	3.00 to 5.00	3.00 to 5.00		
" Lower grades50 to 2.00	.50 to 2.00		
Kaiserin, Carnot50 to 4.00	.50 to 6.00		
Golden Gate, Ivory50 to 4.00	.50 to 3.00		
Carnations, Fancy and Novelties.	1.00 to 1.50	.75 to 1.50		
" Ordinary30 to .50	.25 to .50		
Cattleyas	25.00 to 50.00	25.00 to 50.00		
Lilies	3.00 to 5.00	2.00 to 4.00		
Lily of the Valley	1.00 to 3.00	1.00 to 3.00		
Daisies25 to .50	.25 to .50		
Pansies15 to .50	.25 to .50		
Peonies	1.00 to 6.00	1.00 to 6.00		
Gladioli	4.00 to 8.00	4.00 to 8.00		
Mignonette50 to 1.00	.50 to 1.00		
Gardenias	15.00 to 25.00	3.00 to 20.00		
Sweet Peas per 100 bunches	3.00 to 6.00	1.50 to 4.00		
Adiantum25 to .50 to .50		
Smilax	8.00 to 12.00	6.00 to 10.00		
Asparagus Plumosus, strings	15.00 to 25.00	10.00 to 20.00		
" " & Sprea. (100 bchs.)	15.00 to 25.00	10.00 to 20.00		

Moore, Hentz & Nash,
 Wholesale Commission Florists,
 55 and 57 West 26th Street,
 Telephone No. 756
 Madison Square. **New York.**

REED & KELLER
 122 West 25th St., New York
Florists' Supplies
 We manufacture all our
 Metal Designs, Baskets, Wire Work & Novelties
 and are dealers in
 Glassware Decorative Greens and Florists' Requisites

TRAENDLY & SCHENCK
 WHOLESALE FLORISTS
 Furnish best stock at fair prices all the year round Send for quotations on fall orders
 Tel. 798-799 Madison Sq. 44 West 28th Street, New York City

Alexander J. Guttman
 THE WHOLESALE FLORIST OF NEW YORK
 34 WEST 28th STREET
 PHONES. 1664-1665 MADISON SQUARE
ENOUGH SAID



HARDY CUT FERNS

Sphagnum Moss, Extra Large Bales, per bale, \$1.25. Fancy and Dagger Ferns our specialty. A trial order will convince you that we ship only first-class stock. Headquarters for Florists' supplies and wire work. All cut flowers in season. **BOXWOOD**, per bunch 35c, 50 lbs. \$7.50.
MICHIGAN CUT FLOWER EXCHANGE, INC., All 'phone connections 38-40 Broadway, Detroit, Mich.

FANCY and DAGGER
 Extra fine, \$1.75 per 1000. Bronze and Green Galax, \$1.25 per 1000. Leucothoe Sprays, \$1.00 per 100, \$7.50 per 1000.

Headquarters in Western New York
 FOR
ROSES, CARNATIONS
 And all kinds of Seasonable Flowers
Wm. F. Kasting Co.
 Wholesale Commission Florist, also Dealer in Florists' Supplies and Wire Designs.
383-87 ELLICOTT ST. BUFFALO, N. Y.
 Give us a trial. We can please you.

FRANK S. HICKS & CO.
 Wholesale Florists.
Open Now for Consignments of Cut Flowers.
39 West 28th Street, - New York City
 Tel. 2920 Mad. Sq.

WILLIAM H. KUEBLER
 Brooklyn's Foremost and Best
WHOLESALE COMMISSION HOUSE
 A First Class Market for all CUT FLOWERS
28 Willoughby St., Brooklyn, N. Y.
 Tel. 4591 Main

 **Henry M. Robinson & Co.** 
 Wholesale and Commission
FLORISTS

Hardy Cut Evergreens and Florists' Supplies
 NEW CROP DAGGER AND FANCY FERNS, \$2.00 per M.
15 Province St. and 9 Chapman Place, Boston, Mass.

Flowers and Florists' Supplies
 The best place in AMERICA to buy
BAY TREES
N. F. McCarthy & Co.
84 Hawley St., BOSTON, MASS.
 Largest Dealers in Supplies in New England.

SAMUEL A. WOODROW
WHOLESALE PLANTSMAN
 Palms, Large and Small Ferns, etc.
53 West 30th Street, NEW YORK
 Telephone 2083 Madison

In ordering goods please add "I saw it in HORTICULTURE."

BOSTON FLORIST LETTER CO.
 Manufacturers of **FLORISTS' LETTERS**



This wooden box nicely stained and varnished, 18x30x12, made in two sections, one for each size letter, given away with first order of 500 letters
 Block Letters, 1 1/2 or 2 inch size per 100, \$2.
 Script Letters, 3. Fastener with each letter or word. Used by leading florists everywhere and for sale by all wholesale florists and supply dealers
N. F. McCARTHY, Manager
66 Pearl Street, BOSTON, MASS.

WHOLESALE FLOWER MARKETS. — PER 100. TO DEALERS ONLY.

	CINCINNATI June 16	DETROIT June 15	BUFFALO June 15	PITTSBURG June 16
ROSES				
Am. Beauty, Fab. and Sp.	20.00 to 25.00	20.00 to 25.00	20.00 to 25.00	20.00 to 25.00
“ Extra	15.00 to 20.00	15.00 to 18.00	15.00 to 20.00	15.00 to 18.00
“ No. 1	8.00 to 10.00	8.00 to 15.00	8.00 to 15.00	6.00 to 12.00
“ Lower grades	4.00 to 6.00	3.00 to 6.00	3.00 to 5.00	1.00 to 3.00
Bride, 'Maid, F. & S.	5.00 to 6.00	6.00 to 8.00	6.00 to 8.00	6.00 to 8.00
“ Low. gr.	2.00 to 4.00	3.00 to 6.00	2.00 to 6.00	2.00 to 4.00
Killarney, Richmond, Fab. & Sp.	6.00 to 8.00	6.00 to 8.00	6.00 to 8.00	8.00 to 10.00
“ Lower grades	2.00 to 4.00	3.00 to 6.00	2.00 to 6.00	3.00 to 6.00
Chatenay, Fancy and Special	6.00 to 8.00	6.00 to 8.00	6.00 to 8.00	6.00 to 8.00
“ Lower grades	3.00 to 4.00	3.00 to 6.00	2.00 to 6.00	2.00 to 4.00
Kaiserin, Carnot.	5.00 to 8.00	4.00 to 8.00	3.00 to 7.00	4.00 to 12.00
Golden Gate, Ivory	5.00 to 8.00	4.00 to 8.00	2.00 to 5.00	6.00 to 8.00
CARNATIONS				
Fancy and Novelties	2.00 to 3.00	3.00 to 4.00	1.50 to 2.00 to 2.00
Ordinary	1.00 to 2.00	2.00 to 3.00	1.00 to 1.50	1.00 to 1.50
MISCELLANEOUS				
Cattleyas	40.00 to 50.00	35.00 to 50.00	40.00 to 50.00	40.00 to 50.00
Lilies	8.00 to 10.00	12.50 to	10.00 to 12.00	8.00 to 10.00
Lily of the Valley	3.00 to 4.00	3.00 to 4.00	2.00 to 4.00	3.00 to 4.00
Daisies	.35 to .50	.50 to 1.00	.50 to 1.00 to .50
Pansies	.25 to .35	.50 to 1.00	.30 to .50 to .50
Peonies	2.00 to 4.00	4.00 to 8.00	2.00 to 5.00	4.00 to 5.00
Giadoli to 4.00	3.00 to 8.00	3.00 to 5.00	2.00 to 6.00
Mignonne	1.00 to 2.00	1.00 to	1.00 to 2.00	1.00 to 2.00
Gardenias	1.00 to 2.00	15.00 to 25.00	25.00 to 35.00	15.00 to 25.00
Sweet Peas	.50 to .75	.50 to .75	.40 to .75	.50 to .75
Adiantum	.50 to .75	1.00 to 1.50	.50 to 1.50 to 1.25
Smilax to 1.00	15.00 to 18.00 to 15.00 to 15.00
Asparagus Plumosus, strings	40.00 to 50.00	50.00 to 60.00	50.00 to 60.00	35.00 to 50.00
“ & Spreu. (100 bchs.) to 25.00	30.00 to 50.00	35.00 to 50.00	35.00 to 50.00

H. C. BERNING
Wholesale Florist
1402 Pine Street, ST. LOUIS, MO.

A. MOLTZ
 Will purchase flowers on order in N. Y. market and ship carefully at prevailing wholesale prices. Address
55-57 West 26th Street, New York City

MILLANG BROS.
WHOLESALE COMMISSION FLORISTS
41 West 28th Street
 Telephones 3860 Madison 3861
NEW YORK

CLEARY'S HORTICULTURAL CO.
 Management AMBROSE T. CLEARY
 Wholesale Contracting, Jobbing, Auction
HORTICULTURAL PRODUCTS
 of every description.
 Consignments Received. Surplus Stock Converted.
62 Vesey St., NEW YORK

In writing to Advertisers kindly mention Horticulture

Buyer's Directory and Ready Reference Guide

Advertisements under this head, one cent a word. Initials count as words.

Regular advertisers in this issue are also listed under this classification without charge. Reference to List of Advertisers will indicate the respective pages.

Buyers failing to find what they want in this list will confer a favor by writing us and we will try to put them in communication with reliable dealers.

ACCOUNTANT

R. J. Dysart, 28 State St., Boston.
For page see List of Advertisers.

ARAUCARIAS

A. Leuthy & Co., Perkins St. Nurseries,
Roslindale, Mass.
For page see List of Advertisers.

We have a specially fine lot of Araucarias, the plants at \$1.00 each are extra value for the money.
4 inch..... 50 cents each
5 "..... 75 " "
6 "..... 1.00 " "
Wittbold Co., 1657 Buckingham Place,
Chicago, Ill.

ASPARAGUS

A. N. Pierson, Cromwell, Conn.
Asparagus Plumosus Seedlings.
For page see List of Advertisers.

J. M. Thorburn & Co., 33 Barclay St.,
New York.
Plumosus Nans and P. Robustus.
Erle Floral Co., Erie, Pa.
Asparagus Plumosus and Sprengeri.

Asparagus Plumosa, 2 in. pots. Fine plants, \$2.50 per 100; \$20.00 per 1000. Cash with order or good reference. Erle Floral Co., Erie, Pa., or Wm. F. Kasting Co., 385 Elliott St., Buffalo, N. Y.

ASTER SEED

Altimo Culture Co., Canfield, O.
For page see List of Advertisers.

AUCTION SALES

Cleary's Horticultural Co., 62 Vesey St.,
New York.
For page see List of Advertisers.
Wm. Elliott & Sons, 42 Vesey St.,
New York.
Closing Plant Auction Sale.
For page see List of Advertisers.

AZALEAS

A. Leuthy & Co., Perkins St. Nurseries,
Roslindale, Mass.
For page see List of Advertisers.
August Rolker & Sons, New York, 31 Barclay St., or P. O. Box 752.
For page see List of Advertisers.

BAMBOO CANES

Yokohama Nursery Co., 31 Barclay Street,
New York.
For page see List of Advertisers.

BAY TREES.

N. F. McCarthy & Co., 84 Hawley St.,
Boston.
For page see List of Advertisers.

2000 Bay and Box Trees in all sizes, Pyramid and Standards. Write for list. Julius Roehrs, Rutherford, N. J.

BEDDING PLANTS

R. Vincent, Jr., & Sons Co., White Marsh,
Maryland.
For page see List of Advertisers.
A. N. Pierson, Cromwell, Conn.
For page see List of Advertisers.
A. Leuthy & Co., Perkins St. Nurseries,
Roslindale, Mass.
For page see List of Advertisers.
F. R. Pierson Co., Tarrytown-on-Hudson,
N. Y.
For page see List of Advertisers.
Vern J. Seldaraff, Erie, Pa.
For page see List of Advertisers.

BEDDING PLANTS - Continued

Godfrey Aschmann,
1012 W. Ontario St., Phila., Pa.
For page see List of Advertisers.
40,000 geraniums, 10 best standard sorts;
5000 Vinca variegata; Salvia; heliotrope,
dark; feverfew, double white. Good stock,
prices right. E. D. Kauback & Son, Malden,
Mass.

BEGONIAS

Thomas Roland, Nahant, Mass.
Gloire De Lorraine.
For page see List of Advertisers.
S. S. Skidelsky, 1741 N. 18th St., Phila.
Gloire de Lorraine.
For page see List of Advertisers.
Begonia Gloire Lorraine, strong plants
from leaf cuttings, 2 1-4 inch pots, \$12.00
per 100; \$110.00 per 1000. Julius Roehrs,
Rutherford, N. J.

BOILERS

"Burnham" Boilers made for
greenhouse heating. Lord & Burnham,
1133 Broadway, N. Y.
Kroeschell Bros. Co., 35 Erie St., Chicago.
For page see List of Advertisers.

BUILDERS' AND FARM LEVELS

Bostrom-Brady Mfg. Co., 139 Madison Ave.,
Atlanta, Ga.
For page see List of Advertisers.

BUILDING MATERIAL

BUILDING MATERIAL of all description
for All Cypress, Semi-Iron, Iron
Frame or Truss Houses. Hot Bed Sash
and Frames. Lord & Burnham Co., 1133
Broadway, N. Y.

BULBS AND TUBERS

Joseph Breck & Sons, 47-54 N. Market St.,
Boston.
For page see List of Advertisers.
J. M. Thornburn & Co., 33 Barclay St.,
New York.
For page see List of Advertisers.
A. T. Boddington, 342 W. 14th St., N. Y.
For page see List of Advertisers.
Riekards Bros., 37 East 19th St., New York.
For page see List of Advertisers.
H. F. Mitchell Co., Philadelphia.
For page see List of Advertisers.
H. E. Fiske Seed Co., Faneuil Hall Sq.,
Boston.
For page see List of Advertisers.
James Vick's Sons, Rochester, N. Y.
Fall Bulbs.
For page see List of Advertisers.
Aug. Rolker & Sons, 31 Barclay St., New
York.
Seasonable Import Plants and Bulbs.
For page see List of Advertisers.
K. Velthuys, Hillegom, Holland.
Represented by Felix Bosch, 260 Clarendon
St., Boston.
Bulbs French and Dutch.
For page see List of Advertisers.

A. Mitting, 17-23 Kennan St., Santa Cruz,
California.
Calla Bulbs.
For page see List of Advertisers.

CANNAS

The Conard & Jones Co., West Grove, Pa.
For page see List of Advertisers.
Godfrey Aschmann,
1012 W. Ontario St., Phila., Pa.
For page see List of Advertisers.
The F. R. Pierson Co., Tarrytown-on-
Hudson, N. Y.
For page see List of Advertisers.
E. & C. Woodman, Danvers, Mass.

CARNATIONS

F. Dorner & Sons Co., Lafayette, Ind.
For page see List of Advertisers.
Chicago Carnation Co., Joliet, Ill.
Field Grown.
For page see List of Advertisers.
John E. Haines, Bethlehem, Pa.
Carnations Imperial and Pink Imperial.
For page see List of Advertisers.
A. N. Pierson, Cromwell, Conn.
For page see List of Advertisers.
The F. R. Pierson Co., Tarrytown-on-
Hudson, N. Y.
For page see List of Advertisers.
Albert Roper, Tewksbury, Mass.
Carnation Bay State.
For page see List of Advertisers.
Carnation cuttings of all the leading
varieties at the same price as any reliable
firm. Write for prices before you look
elsewhere. Wm. F. Kasting Co., 385
Elliott St., Buffalo, N. Y.

CARNATIONS! FIELD GROWN!
Enchantress and Winsor, on and after July
1st. Only a few left. To close out quick,
\$55 a thousand. Cash or good reference
with order. Wanoka Greenhouses, Barneveld,
N. Y.

50,000 Field Carnations now ready. Long
Island grown, standard, \$50.00 per 1000;
White Enchantress, Beacon, Winsor, Lloyd,
\$10.00 per 100. Cash. Harlowarden Green-
houses, Greenport, N. Y.

CAULIFLOWER AND CABBAGE SEED

H. Hartmann & Co., Copenhagen,
Denmark.
For page see List of Advertisers.

CHRYSANTHEMUMS

Chas. H. Totty, Madison, N. J.
For page see List of Advertisers.
A. N. Pierson, Cromwell, Conn.
For page see List of Advertisers.
Herrington's book on the Chrysanthemum,
mailed to your address for 50c., by
Horticulture Publishing Co., 11 Hamilton
Place, Boston.

Chrysanthemums ready: 2 1-2 inch strong
stock of Touse, Oct. Frost, Polly Rose,
Wanamaker, and all standards, \$2 per 100;
\$18 per M. New; 2 1-2, strong, Alice Roosevelt,
Hankey, Clay Frick, Winter Cheer,
Rosette, B. May, \$4 per 100, \$30 per M.
Cash. Send for catalog. Harlowarden
Greenhouses, Greenport, N. Y.

Chrysanthemums, strong, healthy plants,
from soil. White, Oph. Geo. S. Kalb, A.
Byron, Ivory, F. Rose, Yellow, Robt. Hal-
liday, Crema, Pink, Glory of Pacific, Min-
nie Bailey, best late pink, \$1.25 per 100,
\$10.00 per 1000. Cash or C. O. D. D. H.
Green, West Grove, Penn.

Have 100,000 fine young well-rooted
'Mums, cuttings of the best 60 commer-
cial varieties. Send for our new and low
price list. Satisfaction guaranteed. Wm.
Ehmann, Jr., Corfu, N. Y.

COBAEAS

Cohaea scandens from 4 in. pots, \$8.00
per 100. Wittbold Co., 1657 Buckingham
Place, Chicago, Ill.

COLEUS

A. N. Pierson, Cromwell, Conn.
For page see List of Advertisers.
Coleus, Versch. and fine assorted, 2 in.,
strong, 2c. Cash. L. E. Marquisee, Syra-
cuse, N. Y.

CONIFERS

John Waterer & Sons, Ltd., American
Nursery, Bagshot, Eng.
For page see List of Advertisers.

For List of Advertisers See Page 837

CUT FLOWER BOXES.

Edwards Folding Box Co., Philadelphia
For page see List of Advertisers.
Folding cut flower boxes, the best made
Write for list. Holton & Hunkel Co., Milwaukee, Wis.

CYCLAMEN.

Cyclamen, finest Giant strain, separate colors, once transplanted seedlings, 2c.; twice transplanted, 3c.; strong, from 2-in. pots, 4c. J. L. Schiller, 929 Prouty Ave., Toledo, O.

DAHLIAS

David Herbert & Son, Atco, N. J.
For page see List of Advertisers.
R. Vincent, Jr. & Sons Co., White Marsh, Maryland.
For page see List of Advertisers.
Dahlias, balance of season, 25 named varieties, postpaid, \$1.00. Catalogue free. J. L. Moore, Northboro, Mass.

DECORATIVE PLANTS

A. Leuthy & Co., Perkins St. Nurseries, Roslindale, Mass.
For page see List of Advertisers.
Godfrey Aschmann, 1012 W. Ontario St., Phila., Pa.
For page see List of Advertisers.

DRACAENAS

E. & C. Woodman, Danvers, Mass.
Dracaena indivisa: 4 in., \$2.00 per doz., \$12.00 per 100; 5 in., \$3.00 per doz., \$20.00 per 100. Wittbold Co., 1657 Buckingham Place, Chicago, Ill.

ECHEVERIAS

Echeverias, \$18 per 1000, post paid. McDowell, Mexico City.

ELECTRIC CIRCULATOR

The Castle Co., 170 Summer St., Boston.
For page see List of Advertisers.

FERNS

A. Leuthy & Co., Roslindale, Mass.
For page see List of Advertisers.
H. H. Barrow & Son, Whitman, Mass.
Nephrolepis Whitman.
For page see List of Advertisers.
John Scott, Brooklyn, N. Y.
For page see List of Advertisers.
The F. R. Pierson Co., Tarrytown-on-Hudson, N. Y.
For page see List of Advertisers.
Nephrolepis Whitman, extra fine ferns, well rooted, \$7.00 per 100; \$27.00 per 1000. Express paid to all points within 500 miles of Rhode Island. Cash with order only. J. F. Barclay, Pawtucket, R. I.

FERNS FOR JARDINIERS

Frank N. Eskesen, Madison, N. J.
For page see List of Advertisers.

FERTILIZERS

Pulverized Manure Co., 31 Union Stock Yards, Chicago, Ill.
Wizard Brand Cattle Manure.
For page see List of Advertisers.
Thos. J. Grey & Co., 32 and 33 South Market St., Boston.
High-Grade Scotch Soot.
For page see List of Advertisers.
Wm. Elliott & Sons, 42 Vesey St., New York.
Sterilized Sheep Manure.
For page see List of Advertisers.

FLORAL PHOTOGRAPHS

Floral Photographs. Foley's 226-228 1-2 Bowery, New York.

FLORISTS' BASKETS

E. H. Hitchcock, Glenwood, Mich.
For page see List of Advertisers.

FLORISTS' LETTERS.

Boston Florist Letter Co., 66 Pearl St., Boston, Mass.
For page see List of Advertisers.

FLORISTS SUPPLIES

N. F. McCarthy & Co., 84 Hawley St., Boston.
For page see List of Advertisers.
M. Robinson & Co., 15 Province St. and 9 Chapman Pl., Boston, Mass.
For page see List of Advertisers.
Reed & Keller, 122 W. 25th St., New York
For page see List of Advertisers.
J. B. Muidoch & Co., 714 Penn Ave., Pittsburg, Pa.
For page see List of Advertisers.
H. Bayersdorfer & Co., 1129 Arch St., Philadelphia.
For page see List of Advertisers.

FLOWERS BY TELEGRAPH

Park Floral Co., Denver, Colo.
For page see List of Advertisers.
J. N. Champlin & Co., 1026 Chapel St., New Haven, Conn.
For page see List of Advertisers.
Gude Bros. Co., 1214 F St., Washington, D. C.
For page see List of Advertisers.
Atlanta Floral Co., Atlanta, Ga.
For page see List of Advertisers.
M. C. & J. E. Hauswirth, 232 Michigan Ave., Chicago.
For page see List of Advertisers.
William J. Smyth, Michigan Ave. and 31st St., Chicago.
For page see List of Advertisers.
George Wittbold Co., 1657-59 Buckingham Place, Chicago.
For page see List of Advertisers.
Jacob Schniz, 644 4th Ave., Louisville, Ky.
For page see List of Advertisers.
Thos. F. Galvin, 124 Tremont St., Boston
For page see List of Advertisers.
Julius A. Zinn, 2 Beacon St., Boston
For page see List of Advertisers.
Houghton & Clark, 396 Boylston St., Boston.
For page see List of Advertisers.
Sidney Hoffman, 59-61 Massachusetts Ave., Boston.
For page see List of Advertisers.
Edward MacMullin, 194 Boylston St., Boston.
For page see List of Advertisers.

J. Breitmeyer's Sons, Miami and Gratiot Aves., Detroit, Mich.
For page see List of Advertisers.
Samuel Murray, 1017 Broadway, Kansas City, Mo.
For page see List of Advertisers.
Wm. L. Rock Flower Co., 1116 Walnut St., Kansas City, Mo.
For page see List of Advertisers.
Fred C. Weber, 4326-28 Olive St., St. Louis, Mo.
For page see List of Advertisers.
G. G. Eyres, 11 N. Pearl St., Albany, N. Y.
For page see List of Advertisers.
David Clarke's Sons, 2159-2141 Broadway New York.
For page see List of Advertisers.
Alex. McConnell, New York.
For page see List of Advertisers.
Robert G. Wilson, Fulton St. & Greene Av., Brooklyn, N. Y.
For page see List of Advertisers.
Young & Nugent, 42 W. 28th St., N. Y.
For page see List of Advertisers.
J. H. Dunlop, 96 Yonge St., Toronto, Can.
For page see List of Advertisers.

FLOWER BOXES

Illinois Heater & Mfg. Co., 3946 Wentworth Ave., Chicago, Ill.
Self Waterlug for Windows, Porches and Cemeteries.

FLOWER POTS

W. H. Ernest, 28th and M Sts., Washington, D. C.
For page see List of Advertisers.
A. H. Hews & Co., Cambridge, Mass.
For page see List of Advertisers.
Hilfinger Bros., Ft. Edward, N. Y.
For page see List of Advertisers.
Red pots, seed pans, etc.
The Peters & Reed Pottery Co., Zanesville, O.

GALAX

Michigan Cut Flower Co., 38 and 40 Broadway, Detroit, Mich.
For page see List of Advertisers.

GERANIUMS

R. Vincent Jr. & Sons Co., White Marsh, Md.
New and Standard Varieties.
For page see List of Advertisers.
Godfrey Aschmann, 1012 W. Ontario St., Phila., Pa.
For page see List of Advertisers.
Wm. W. Edgar Co., Waverley, Mass.

3000 Nutt Geraniums, in bloom, 4 in., \$5.00 per 100. 500 mixed Colons, 2 1/2 in., \$2.00 per 100. Would trade for carnations. Joseph Croucher, 1905 West Third Street, Chester, Pa.

GLADIOLI

Gladiolus, large flowering mixed, balance of season, \$1.00 per 100; postpaid. J. L. Moore, Northboro, Mass.

GLASS

Boston Plate & Window Glass Co., Boston.
For page see List of Advertisers.
Standard Plate Glass Co., 26-30 Sudbury St., Boston.
For page see List of Advertisers.
S. Jacobs & Sons, 1365-79 Flushing Ave., Brooklyn, N. Y.
Metropolitan Material Co., 1398-1408 Metropolitan Ave., Brooklyn, N. Y.
For page see List of Advertisers.
Foley Mfg. Co., Western Ave., between 25th & 26th Sts., Chicago.
Sharp, Partridge & Co., 22d & Lumber St., Chicago.
For page see List of Advertisers.

Greenhouse glass, lowest prices. Johnston Glass Co., Hartford City, Ind.

GLASS, High Grade, Double Thick Greenhouse Glass. Lord & Burnham, 1133 Broadway, N. Y.

GLAZING POINT

H. A. Dreer, Philadelphia, Pa.
For page see List of Advertisers.
GLAZING POINTS, Lord & Burnham Special Glazing Nails (Points). Lord & Burnham, 1133 Broadway, N. Y.

GREENHOUSE BUILDING MATERIAL

Lord & Burnham Co., 1133 Broadway, New York.
For page see List of Advertisers.
Pierson U-Bar Co., 1 Madison Sq., N. Y.
For page see List of Advertisers.
A. T. Stearns Lumber Co., Neponset, Boston.
For page see List of Advertisers.
King Construction Co., N. Tonawanda, New York.
For page see List of Advertisers.
J. C. Moninger Co., 117 East Blackhawk St., Chicago, Ill.
For page see List of Advertisers.

Foley Mfg. Co., Western Ave., between 25th & 26th Sts., Chicago.
For page see List of Advertisers.
I. Cassidy, Summer Ave. and Erie R. R., Newark, N. J.
For page see List of Advertisers.

Geo. B. Doane, 18 Midway St., Boston. Iron Pipe.
For page see List of Advertisers.

S. Jacobs & Sons, 1365-79 Flushing Ave., Brooklyn, N. Y.

Wm. H. Lutton, West Side Avenue Sta., Jersey City, N. J.
For page see List of Advertisers.

Metropolitan Material Co., 1398-1408 Metropolitan Ave., Brooklyn, N. Y.
For page see List of Advertisers.

In writing to Advertisers kindly mention Horticulture

POT HANGERS

Pot hangers, Kramer's \$1 doz. by exp. \$1.25 by mail. I. N. Kramer & Son, Cedar Rapids, Ia.

PRIMULA SEED

H. E. Fiske Seed Co., 13 Faneuil Hall Sq., Boston.

For page see List of Advertisers.

O. V. Zaugen, Hoboken, N. J.
For page see List of Advertisers.

RAFFIA

Raffia (colored), 20 beautiful shades samples free. R. H. Comey Co., Camden, N. J.; 810 Washburn Ave., Chicago, Ill.

RETAIL FLORISTS

Park Floral Co., Denver, Colo.
For page see List of Advertisers.

Gude Bros. Co., 1214 F St., Washington, D. C.
For page see List of Advertisers.

Atlanta Floral Co., Atlanta, Ga.
For page see List of Advertisers.

M. C. & J. E. Hauswirth, 232 Michigan Ave., Chicago.

For page see List of Advertisers.

William J. Smyth, Michigan Ave. and 31st St., Chicago.

For page see List of Advertisers.

George Wittbold Co., 1637-59 Buckingham Place, Chicago.

For page see List of Advertisers.

Jacob Schatz, 644 4th Ave., Louisville, Ky.

For page see List of Advertisers.

Thos. F. Galvin, 124 Tremont St., Boston.

For page see List of Advertisers.

Julius A. Zinn, 2 Beacon St., Boston.

For page see List of Advertisers.

Houghton & Clark, 396 Boylston St., Boston.

For page see List of Advertisers.

Sidney Hoffman, 59-61 Massachusetts Ave., Boston.

For page see List of Advertisers.

Edward MacMulkin, 194 Boylston St., Boston.

For page see List of Advertisers.

J. Bretmeyer's Sons, Detroit, Mich.

For page see List of Advertisers.

Samuel Murray, 1017 Broadway, Kansas City, Mo.

For page see List of Advertisers.

Wm. L. Rock Flower Co., 1116 Walnut St., Kansas City, Mo.

For page see List of Advertisers.

Fred C. Weber, 4326 Olive St., St. Louis, Mo.

For page see List of Advertisers.

J. N. Champlon & Co., 1026 Chapel St., New Haven, Conn.

For page see List of Advertisers.

H. G. Eyres, 11 N. Pearl St., Albany, N. Y.

For page see List of Advertisers.

David Clarke's Sons, 2139-2141 Broadway, New York.

For page see List of Advertisers.

Alex. McConnell, New York.

For page see List of Advertisers.

Robert G. Wilson, Fulton St. and Greene Ave., Brooklyn, N. Y.

For page see List of Advertisers.

Young & Nugent, 42 W. 28th St., N. Y.

For page see List of Advertisers.

J. H. Dunlop, 96 Yonge St., Toronto, Can.

For page see List of Advertisers.

RHODODENDRONS

John Waterer & Sons, Ltd., American Nursery, Bagshot, England.

For page see List of Advertisers.

P. Ouwerkerk, Hoboken, N. J.

For page see List of Advertisers.

Eastern Nurseries, Jamaica Plain, Mass.

Hardy Hybrid and Dwarf Rhododendrons.

For page see List of Advertisers.

ROSES

Bay State Nurseries, N. Abington, Mass.

For page see List of Advertisers.

Robert Craig Co., Market and 49th Sts., Philadelphia, Pa.

For page see List of Advertisers.

ROSES—Continued

Dingee-Conard Co., West Grove, Pa.
For page see List of Advertisers.

R. & J. Farquhar & Co., 6 and 7 South Market Street, Boston.
For page see List of Advertisers.

The E. G. Hill Co., Richmond, Ind.
Roses, Rheu Reid, American Beauty.

Poehlmann Bros. Co., Morton Grove, Ill.
Mrs. Potter Palmer, Cardinal, Beauty.
For page see List of Advertisers.

P. R. Quinlan, Syracuse, N. Y.
Killarney, Richmond, Bridesmaids.
For page see List of Advertisers.

Leo Niessen Co., 1209 Arch St., Phila., Pa.
Rose Plants Ready.
For page see List of Advertisers.

P. Ouwerkerk, P. O. No. 2, Hoboken, N. J.
For page see List of Advertisers.

Eric Floral Co., Erie, Pa.
Low-budded roses, No. 1, \$95.00; No. 11-2, \$65.00 1000. H. T. Jones, Elizabeth, N. J.

S. A. F. CONVENTION ACCOMMODATIONS

Tower Hotel, Niagara Falls, N. Y.
For page see List of Advertisers.

SALVIAS

Cohanzie Carnation Co., New London, Ct.
Salvia Splendeus.

SEEDS

T. J. Grey Co., 32 So. Market St., Boston, Mass.
For page see List of Advertisers.

Joseph Breck & Sons, 51 and 52 N. Market St., Boston, Mass.
For page see List of Advertisers.

W. Atlee Burpee & Co., Philadelphia.
For page see List of Advertisers.

J. M. Thorburn & Co., 33 Barclay St., N. Y.
For page see List of Advertisers.

Arthur T. Boddington, 342 W. 14th St., New York.
For page see List of Advertisers.

H. F. Mitchell Co., 1017 Market St., Phila.
For page see List of Advertisers.

James Vlek's Sons, Rochester, N. Y.
Vlek's Superb Pansy Seed.
For page see List of Advertisers.

Hjalmar Hartmann & Co., 12 Stormgade, Copenhagen, Denmark.
Cauliflower and Cabbage Seed.
For page see List of Advertisers.

Riekards Bros., 37 E. 19th St., New York.
For page see List of Advertisers.

R. & J. Farquhar & Co., 6-7 So. Market St., Boston.
For page see List of Advertisers.

Braslan Seed Growers Co., San Jose Cal.
For page see List of Advertisers.

H. E. Fiske Seed Co., Faneuil Hall Sq., Boston.
Primula Fringed Sineusis.
For page see List of Advertisers.

O. V. Zaugen, Hoboken, N. J.
For page see List of Advertisers.

John F. Rupp, Shiremanstown, Pa.
Chinese Primrose, Cineraria, Giant Pansy Seeds.
For page see List of Advertisers.

SMILAX

Smilax, choice young plants from fall; \$3.00 per 1000, 2000 for \$5.00, 5000 for \$10.00; 50c. per 100 by mail. F. A. Baller, Bloomington, Ill.

Smilax, strong, 2-4 in. pots, \$1.75 per 100; \$15.00 per 1000. Seedlings, 25 cents per 100; \$2.00 per 1000. Wm. Livesey, McCabe St., New Bedford, Mass.

SPHAGNUM MOSS

Live Sphagnum moss, orchid peat and orchid baskets always on hand. Lager & Hurrell, Summit, N. J.

Fresh, clean, 5 lb. bale, \$1.25; 2 bales, \$2.25; 5 bales, \$5.00; 10 bales, \$9.50. Cash. H. R. Abers, Chatsworth, N. J.

SPRAYERS

Charles J. Jager Co., 281-85 Franklin St., Boston.
For page see List of Advertisers.

"SHOWERMAKER," \$1. Jos. Kopesay, So. Bend, Ind.

STEAM TRAP

E. Hippard, Youngstown, O.
For page see List of Advertisers.

SWEET PEAS

A. C. Zvolanek, Round Brook, N. J.
Winter Flowering.
For page see List of Advertisers.

TO-BAK-INE

E. H. Hunt, Genl. Agt., 76-78 Wabash Av., Chicago.
For page see List of Advertisers.

TUBEROSES

Stump & Walter Co., 50 Barclay St., New York.
For page see List of Advertisers.

No. 1 Pearl Tuberose bulbs, \$5.00 per 100. Schlegel & Fottier Co., 26 South Market St., Boston.

VEGETABLE PLANTS

R. Vincent, Jr. & Sons Co., White Marsh, Maryland.
For page see List of Advertisers.

W. W. Edgar Co., Waverley, Mass.
Tomato Plants.

VENTILATING APPARATUS

Pearson U-Bar Co., 1 Madison Sq., N. Y.
For page see List of Advertisers.

Foley Mfg. Co., Western Ave., between 25th & 26th Sts., Chicago.
For page see List of Advertisers.

John A. Payne, 260-274 Culver Ave., Jersey City, N. J.
For page see List of Advertisers.

The Advance Co., Richmond, Ind.
For page see List of Advertisers.

Quaker City Machine Co., Richmond, Ind.
20th Century Ventilating Arm.
For page see List of Advertisers.

VENTILATING MACHINERY, New Model encased, self-oiling gear; Standard Model Open Gear. Lord & Burnham, 1133 Broadway, N. Y.

VERBENAS

Cohanzie Carnation Co., New London, Conn.
Lemon Verbena.

VIOLETS.

Lady Campbell violets, 25,000 extra fine, sand-rooted cuttings, \$1.00 per 100, by mail; \$7.00 per 1000, by express; 500 at 1000 rate. Satisfaction guaranteed. Field-grown plants of Campbell and California ready in August. Chas. Black, Hightstown, N. J.

Maria Louise and Farquhar violet plants, strong, February and March sand struck, clean and free from disease, \$2.00 per 100; \$15.00 per 1000. Will be ready May 15. Cash with order, please. C. Lawritzen, Box 261 Rhinebeck, N. Y.

How to Make Money Growing Violets, will be sent postpaid for 25c., by Horticulture Publishing Co., 11 Hamilton Place, Boston.

Commercial Violet Culture, by B. T. Gal- loway, sent postpaid for \$1.50, by Horticulture Publishing Co., 11 Hamilton Place, Boston.

Violet Marie Louise, No. 1 sand rooted cuttings for sale. Write for prices. Alva Bishop, P. O. Box 163, Rhinebeck, N. Y.

In writing to Advertisers kindly mention Horticulture

VINCAS

Erne Floral Co., Erne, Pa.

Vinca, var., also green, extra heavy 4 1/2 in., leaf 2 1/2 in., good. 2c. Cash L. E. Marquisee, Syracuse, N. Y.

E. & C. Woodman, Danvers, Mass.

WIRED TOOTHPICKS

W. J. Cowee, Berlin, N. Y.

For page see List of Advertisers.

WIREWORLD

Reed & Keller, 122 W. 25th St., N. Y.

For page see List of Advertisers.

Welgel & Uffalussy, 136-138 W. 28th St., New York.

Florists' Wire Designs and Supplies.

For page see List of Advertisers.

Wirework. Write for our catalogue. Holton & Hunkel Co., Milwaukee, Wis.

William E. Heilscher's Wire Works, 38-40 Broadway, Detroit, Mich.

Headquarters for wire work. Send for list. Ball & Betz, 31 E. 3rd St., Cincinnati, O.

WHOLESALE FLORISTS

Boston

N. F. McCarthy & Co., 84 Hawley St., Boston.

For page see List of Advertisers.

H. M. Robinson & Co., 15 Province St. and 9 Chapman Pl., Boston.

For page see List of Advertisers.

Welch Bros., 226 Devonshire St., Boston.

For page see List of Advertisers.

Buffalo

Wm. F. Kasting Co., 383-87 Ellicott St., Buffalo, N. Y.

For page see List of Advertisers.

Chicago

Chas. W. McKellar, 51 Wabash Ave., Chicago.

For page see List of Advertisers.

Peter Reinberg, 51 Wabash Ave., Chicago.

For page see List of Advertisers.

E. F. Winterson Co., 45-49 Wabash Ave., Chicago.

For page see List of Advertisers.

J. A. Budlong, 37-39 Randolph St., Chicago.

For page see List of Advertisers.

Detroit

Michigan Cut Flower Exchange, 38 and 40 Broadway, Detroit, Mich.

For page see List of Advertisers.

Minneapolis

Rice Bros., 115 N. 6th St., Minneapolis, Minn.

For page see List of Advertisers.

New York

J. K. Allen, 106 W. 28th St., New York

For page see List of Advertisers.

J. S. Fenrich, 110 W. 28th St., New York

For page see List of Advertisers.

Ford Bros., 48 W. 28th St., New York

For page see List of Advertisers.

H. E. Froment, 57 W. 28th St., New York

For page see List of Advertisers.

Alex. J. Guttman, 34 W. 28th St., New York

For page see List of Advertisers.

E. C. Horan, 55 W. 28th St., New York

For page see List of Advertisers.

A. H. Langjahr, 55 W. 28th St., New York

For page see List of Advertisers.

James McManus, 42 W. 28th St., New York

For page see List of Advertisers.

John I. Raynor, 49 W. 28th St., New York

For page see List of Advertisers.

W. F. Sheridan, 39 W. 28th St., New York

For page see List of Advertisers.

Traendly & Schenck, 44 W. 28th St., New York

For page see List of Advertisers.

Moore, Heintz & Nssh, 55 and 57 W. 28th St., New York

For page see List of Advertisers.

Frank S. Hicks & Co., 39 W. 28th St., New York

For page see List of Advertisers.

New York—Continued

Wm. H. Kuebler, 28 Willoughby St., Brooklyn, N. Y.

For page see List of Advertisers.

Philip F. Kessler, 55 and 57 W. 28th St., New York.

For page see List of Advertisers.

A. Moltz, 55-57 W. 28th St., New York.

For page see List of Advertisers.

Millang Bros., 41 W. 28th St., New York.

For page see List of Advertisers.

Philadelphia

W. E. McKissick, 1619-1621 Ranstead St., Philadelphia, Pa.

For page see List of Advertisers.

Leo Nlessen Co., 1209 Arch St., Philadelphia, Pa.

For page see List of Advertisers.

The S. S. Pennock-Meehan Co., 1608-16 Ludlow St., Philadelphia, Pa.

For page see List of Advertisers.

Edward Reid, 1523 Ranstead St., Philadelphia, Pa.

For page see List of Advertisers.

Pittsburg

J. B. Murdoch & Co., 714 Penn Ave., Pittsburg, Pa.

For page see List of Advertisers.

St. Louis

H. G. Bernalg, 1402 Pine St., St. Louis, Mo.

For page see List of Advertisers.

WHOLESALE PLANTS MAN

Samuel A. Woodrow, 53 W. 30th St., New York.

For page see List of Advertisers.

WILD SMILAX

E. A. Beaven, Evergreen, Ala. Southern Wild Smilax; Log Mosses.

For page see List of Advertisers.

New Offers in This Issue.

CATTLEYA DOWIANA.

Lager & Hurrell, Summit, N. J.

For page see List of Advertisers.

FOR SALE, LEASE, GOOD WILL, ETC.

Wm. Graham Co., 504 S. 13th St., Phila. David Rust, Receiver.

For page see List of Advertisers.

ORCHIDS. SPECIAL OFFER.

Ordonez Bros., Madison, N. J.

For page see List of Advertisers.

POT CHRYSANTHEMUMS: FERNS FOR DISHES.

Frank Oechslin, 2570-2906 W. Adams St., Chicago.

For page see List of Advertisers.

ROSES. DRACENAS. HYDRANGEA OTAKSA, VINCAS.

John C. Hatcher, Amsterdam, N. Y.

For page see List of Advertisers.

SEEDS. PANSY BODDINGTON'S CHALLENGE.

Arthur T. Boddington, 342 W. 14th St., New York.

For page see List of Advertisers.

SEEDS. SWEET PEAS FOR FORCING.

Henry F. Michell Co., Philadelphia.

For page see List of Advertisers.

1-YEAR TRANSPLANTED PEONY CLUMPS.

The E. G. Hill Co., Richmond, Ind.

For page see List of Advertisers.

SITUATIONS WANTED

GOOD MEN

When you need good men, skilled or unskilled, Write:

THOS. H. BAMBRICK

34 South 7th Street Philadelphia

Help of all kinds, including that for Florists, Nurserymen, Seedsmen and the Horticultural trade generally.

HELP WANTED

A GOOD side line for salesmen calling on greenhouses, etc. Pocket samples, State territory and references. Factory, P. O. Box 1371, New York.

FOR SALE

FOR SALE Greenhouses. About 30,000 feet of glass in first-class condition, well stocked with roses; fine location for retail trade. Handy to Boston market for wholesale; chance of a life time. Reason for selling: all my time is taken up with other business. Write for particulars or call and see them. Address H. F. Crawford, Montpelier Station, Brockton, Mass.

FOR SALE—Special—Glass for sale below cost. 16 x 24 double thick American A. & B. qualities, below cost, for immediate acceptance. Never such an opportunity offered before. Write Parsheley Bros., 59 Montrose Ave., Brooklyn, N. Y.

FOR SALE—27,000 feet of glass; filled with first-class stock; located in one of Chicago's suburbs; low price. Address Florist, 4016 N. Clark St., Chicago.

NEWS NOTES.

Mr. A. Warren Spalding has opened a florist shop in Newport, R. I.

A. Van Pelt has started in the nursery and market gardening business at Havelock, Neb.

The Blackman Floral Co., Evansville, Ind., are to have a new front in their store at 402 Main street.

The greenhouses of M. Ullenbruch, Port Huron, Mich., were badly damaged by an electrical and wind storm on June 8.

As the result of a hailstorm on May 29 a large quantity of stock in the houses of W. A. Schaefer, Platteville, Wis., was ruined.

William Didden, Mt. Moriah Lane, has purchased a farm at Yeadon, Del. Co., Pa. Two greenhouses and a dwelling house are part of the improvements already in evidence. Mr. Didden is now residing at the new place, and his son, George, is taking care of the old business at Mt. Moriah.

FIRE RECORD.

The greenhouses of F. F. Shepardson, Mansfield, Mass., were entirely destroyed by fire on June 11. Loss about \$1000.

Fire gutted the plant of the American Seeding Company, Louisville, Ky., with a loss of about \$50,000 to plant and building.

F. F. Shepardson, who raises cucumbers extensively at Mansfield, Mass., sustained a loss of about \$2000 on June 11 from fire. Cause unknown; no insurance.

List of Advertisers

Page	Page
Advance, The Co. 839	Leuthy A. & Co. 810
Allen J. K. 830	Lord & Burnham Co. 840
Altum Culture Co. 875	Lutton W. H. 849
American Nursery 812	Maeda Jos. A. 823
American Nursery Co. 812	MacMullen E. A. 827
Aschmann G. 811	McCarthy N. F. & Co. 831
Atlanta Floral Co. 826	McConoell Alex. 826
Bambrick Thos. H. 836	McKellar Charles W. 828
Barrows H. H. & Son. 821	McKissick, W. E. 828
Bayersdorfer H. & Co. 819	McManus Jas. 830
Bay State Nurseries. 812	Metropolitan Ma- terial Co. 838
Beaver E. A. 838	Michell H. F. Co. 24-825
Berning H. G. 831	Michigan Cut Flower Exchange. 831
Boddingtoo A. T. 810-825	Millang Bros. 81
Boston Florist Letter Co. 831	Mitting, A. 810
Boston Plate and Win- dow Glass Co. 837	Moltz, A. 811
Bosch, Felix. 811	Moninger J. C. 838
Bostrom-Brady Mfg. Co. 829	Moore, Heatz & Nash. 830
Brasian Seed Growers Co. 825	Murdoch J. B. & Co. 828
Breck Joseph & Sons. 825	Murray Samuel. 826
Brettmeyer's J. Sons. 826	Niessen Leo. Co. 828
Bridgeman's Seed Warehouse. 825	Ordenez Bros. 823
Budlong J. A. 825	Ouwkerk P. 812
Burpee W. A. & Co. 825	Paethorpe P. R. Co. 824
Carrillo & Baldwin. 823	Park Floral Co. 826
Cassidy I. 839	Payne John A. 837
Castle Co. 838	Peacock-Meehan Co. 828
Champion J. N. & Co. 826	Perkins-St. Nurseries. 810
Chicago Carnation Co. 811	Pierce F. O. Co. 839
Clarke's David, Sons. 827	Pierson, A. N. 810
Clary's Horticultural Co. 831	Pierson F. R. Co. 811
Cowee W. J. 827	Pierson U Bar Co. 840
Craig, Robt. Co. 812	Peehlmann Bros. Co. 82
Dingee & Conard Co. 82	Pulverized Manure Co. 824
Doane Geo. B. & Son. 839	Oechslin Frank. 811
Dorner F. Sons & Co. 811	Quaker City Machine Co. 839
Dreer H. A. 837-840	Quinlan P. R. 812
Duoplog John H. 826	Raygor John L. 830
Dysart R. J. 88	Reed & Keller. 830
Eastern Nurseries. 812	Reid Edw. 828
Edwards Folding Box Co. 828	Reimberg Peter. 828
Elliott Wm & Sons. 821-824	Rice Bros. 828
Ester J. G. 839	Rickards Bros. 825
Ernest W. H. 837	Robinson H. M. & Co. 841
Eskersen Frank K. 812	Rock Wm. L. Flo. Co. 826
Eyres. 826	Roehrs Julius Co. 823
Farquhar R. & J. & Co. 812	Rohr Albert. 811
Feurich J. S. 830	Rolaud, Thomas. 810
Fiske, H. E. Seed Co. 824-825	Rolker August & Sons Co. 810-837
Foley Mfg. Co. 839	Rose Hill Nurseries. 810
Ford Bros. 830	Rupp J. F. 825
Fromet H. E. 830	Rust David. 821
Galvin Thos. F. 827	Sander & Son. 823
Graham Wm. Co. 821	Schlurff Vern L. 810
Grey T. J. Co. 825	Schulz Jacob. 826
Gude Bros. Co. 826	Scott, John. 821
Guttman Alex. J. 830	Sharp, Partridge & Co. 838
Haerens A. 810	Sheridan W. F. 810
Hall Asso. 839	Siggers & Siggers. 837
Haines, J. E. 811	Situations & Wants. 846
Hartmann Hjalmar & Co. 825	Skidelsky S. S. 810
Hatcher, John C. 827	Smyth Wm. J. 826
Hauswirth M. C. & J. E. 826	Standard Plate Glass Co. 838
Heacock Joseph. 812	Stearns A. T. Lumber Co. 839
Herbert David & Son. 810	Stumpp & Walter Co. 810-824
Hews A. H. & Co. 837	Thorburn J. M. & Co. 825
Hicks Frank S. & Co. 831	Totty Chas. H. 812
Hilfinger Bros. 87	Tower Hotel. 828
Hill, The E. G. Co. 812	Traendly & Schenck. 80
Hippard F. 838	Valentine, J. A. 826
Hitchcock E. H. 827	Velthuys K. 811
Hoenig M. J. 88	Vick's Jas. Sons. 825
Hoffman. 87	Vincent R. Jr. & Sons, Co. 810-811
Horan E. C. 830	Waterer John & Sons. 812
Houghton & Clark. 827	Weathered Co. 840
Hunt E. H. 824	Weber F. C. 826
Jager, Chas. J. Co. 824	Welch Bros. 828
Kastig W. F. 831	Weigel & Ujfalussy. 827
Kentucky Tobacco & Product Co. 844	Wilson. 826
Kessler, P. F. 811	Winterson, E. F. Co. 828
King Cons. Co. 839	Withold Geo. Co. 826
Kroeschell Bros. 838	Woodrow, Sam'l A. 831
Kuebler Wm H. 821	Yokohama Nursery Co. 811
Lager & Hurrell. 823	Young & Nugent. 826
Langjahr, Alfred H. 830	Zangen O. V. 825
	Zinn Julius A. 827
	Zovlneck A. C. 825

SPRING PLANT TRADE.

Reports from Indianapolis are to the effect that this season's trade has by far exceeded that of any previous year in the bedding plant line, veranda boxes being largely in evidence. There has been an exceptional call for laurel, bay and boxwood trees.

Minneapolis reports that planting of deciduous plants is about done for this spring; the same with conifers. Bedding is in full swing and will probably last for another week or two as owing to the rainy and cold weather orders are coming in late.

A few belated orders are still coming in but the Chicago bedding season is about over. The storemen are now stocking up of Boston ferns, palms, araucarias, aspidistras and other greens. The plant growers generally seem to feel that the close of the season finds them with nothing to regret unless it is that they did not have stock enough to sell.

Detroit reports outdoor plantings nearly all finished and most growers cleaned up at the usual prices. This fact should be appreciated by the public because, thanks to the instability of the growers, no uniformity in prices could be agreed upon and consequently better varieties produced with more expense than ten years ago were offered as low as the price of ten years ago. Local parks have used up close to a half million of plants for flower beds of various descriptions.

GREENHOUSES BUILDING OR CONTEMPLATED.

Sandusky, O.—City Parks, one house, Norfolk, Va.—Park Department, range of houses.

Negaunee, Mich.—Cleveland Cliffs Iron Co., range of houses.

Danbury, Conn.—J. E. Cornell, house 30x70; boiler room, 10x20.

The Globe Floral Co of Evanston, a northern suburb of Chicago, have just purchased six acres of land close to the terminus of the Evanston branch of the North Western Elevated. Their greenhouse plant was torn down to give right of way for the drainage canal, and they received \$27,000 for it. The Globe Floral Co. have their new range well under way and a fine residence is completed.

DREER'S

Florist Specialties.
KEYSTONE CEDAR PLANT TUBS.



	diam.	Each	Doz.	100.
A	11 in.	.05	7.15	55.00
B	12 1/2 "	.07	8.25	65.00
C	13 1/2 "	.08	9.35	75.00
D	14 1/2 "	1.00	11.00	90.00
E	15 1/2 "	1.25	13.75	110.00
F	16 1/2 "	1.50	16.50	130.00

Three largest sizes have handles
Special PAUL TUBS.
8 inches. 30 3.50 28.00
11 " 30 3.50 28.00
Painted Green.

HENRY A. DREER,
714 Chestnut Street,
PHILADELPHIA, PA.

BOSTON PLATE & WINDOW GLASS CO.

GREENHOUSE GLASS

German and American

261 to 287 A St., Boston 20-22 Canal St.

**JOHN A. PAYNE
GREENHOUSE
Designer & Builder**

260-274 Culver Ave.
JERSEY CITY, N. J.



**IRON FRAME
SEMI-IRON FRAME
TRUSS ROOF
WOOD FRAME
Material Only or Erected**
Everything for the Greenhouse



STANDARD FLOWER POTS

Packed in small crates, easy to handle.

Price per crate		Price per crate	
1500 2 1/2 in. pots in crate	\$4.88	120 7 in. pots in crate	\$4.20
1500 3 1/4 " " "	5.25	60 8 " " "	3.00
1500 3 1/2 " " "	6.00	HAND MADE	
1000 3 " " "	5.00	48 9 in. pots in crate	\$3.60
800 3 3/4 " " "	5.80	48 10 " " "	4.80
500 4 " " "	4.50	34 11 " " "	3.60
320 5 " " "	4.51	24 12 " " "	4.80
144 6 " " "	3.16	6 16 " " "	4.50

Seed pans, same price as pots. Send for price list of Cylinders for Cut flowers, Hanging Baskets, Lawn Vases, etc. Ten per cent. off for cash with order. Address **Hilfinger Bros., Pottery, Fort Edward, N. Y.** August Rolker & Sons, Agts., 31 Barclay St., N. Y. City.

Standard Flower.. POTTS

If your greenhouses are within 500 miles of the Capitol, write us, we can save you money

W. H. ERNEST

28th and M Street WASHINGTON D. C.

PATENTS
Trademarks and Copyrights

Send your business direct to Washington. Saves time and insures better service. Personal attention guaranteed. Twenty-five years' active service. SPECIALTY: "Working on the Failure of Others."

SIGGERS & SIGGERS

PATENT LAWYERS

Box 9, National Union Building
Washington, D. C.

Is Your Name In The Above List? If Not, Why Not?

Kroeschell Boiler Facts

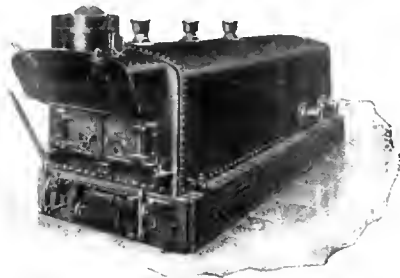

CONTROL. Our boiler is the **most easily controlled** of any boiler made, either when used to its utmost capacity, or when doing very light duty. Those who are using them at full rated capacity write us that they do the full rating with economy; and would do more if necessary.

On the other hand, we could give you names of parties, for example, who have our No. 10 boiler (which has a capacity of 1,250 square feet of glass), and who are heating but one house 20 x 100, which is practically only one-tenth of the capacity of this boiler, and **under these extraordinary conditions, the boiler is perfectly controlled**, economical in the consumption of fuel and satisfactory in every respect.

The object in buying so large a boiler under these conditions is to provide for future increase of greenhouses. We find through experience that this plan is by far more satisfactory and cheaper than to depend upon increasing your boiler capacity by adding sections to cast iron boilers.

MATERIAL. All material is **flange boiler plate**, except the door rings and mud rings which are **wrought iron 2 x 3**. Tubes are best **Charcoal Iron**. Flange boiler plate is the same as used in high pressure, tubular or locomotive boilers; it cannot crack, is many times stronger than cast iron and is a much better conductor of heat.

OPENINGS. Can give you any kind or size of openings you may order. See page 16 of our catalogue.

WORKMANSHIP. We have most skilled workmen, and give the building of each boiler our personal supervision; these boilers are all **made to order** and are no cheap factory made goods.

These boilers are delivered complete and ready to fire up as soon as they are placed on the small brick foundation. Brick work can be built by any Florist.

KROESCHELL BROS. CO., 35 ERIE ST., CHICAGO

Don't Build

without first investigating the best device ever invented for *Heating Economy.*

Don't Repair

until you have got some information as to how we can help you by installing the

ELECTRIC CIRCULATOR

State your proposition and we will reply promptly. It will cost you nothing but a two cent stamp.

THE CASTLE COMPANY, HEATING ENGINEERS
170 Summer Street, - BOSTON, MASS.

OTHER BUSINESS MEN MAY "EASE UP"

during the heated term but the florist does not. His greenhouses must be repaired and it takes **Glass and Pipes and Lumber** to do it.

Now is the time to advertise if you want his trade

His Boiler must be made right now: if you sell heating apparatus get him to buy a new one. Perhaps the time has come for a new watering system. You can reach him most effectually through an advertisement in these pages,

JUST NOW.

THE STANDARD STEAM TRAP

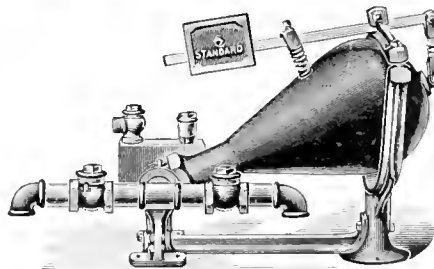

is acknowledged the best for the florist, because it is durable and does its work without trouble and annoyance, saving its cost by the economy in coal bills.

E. HIPPARD
YOUNGSTOWN, OHIO

METROPOLITAN MATERIAL CO.

GREENHOUSE WRECKERS

GLASS Look at these prices New American 50 ft. to the box, 10 x 12 single \$1.60 per box, 10x12, 12x12 B. double \$2.00 per box, 12x14 to 12x20, 14x14 to 14x20, 16x10 and 16x18 B. double at \$2.15 per box, and 10x20, 10x24, 12x24 B. double \$2.26 per box. Discount on large quantities. Let us quote you on

CYPRESS MATERIAL HOTBED SASH BOILERS PIPE FITTINGS HOTBED FRAMES TATS

1398-1408 METROPOLITAN AV., BROOKLYN, N. Y.

GREENHOUSE CONSTRUCTION LUMBER

John C. Moninger Co.
117 E. Blackhawk St., CHICAGO

STANDARD PLATE GLASS CO.

Manufacturers—Importers—Jobbers

NOW IS THE TIME TO BUY

FRENCH OR AMERICAN GREENHOUSE GLASS

LOWEST PRICES ON REQUEST

26-30 Sudbury St. BOSTON, MASS. 61-63 Portland St.

GLASS

Always Write Us Before Buying SHARP, PARTRIDGE & CO.
22nd and Lumber Streets, CHICAGO
WE HAVE SOME SNAPS

Prices Quoted in these Columns are for Dealers Only. When Writing to Advertisers Please Mention HORTICULTURE.

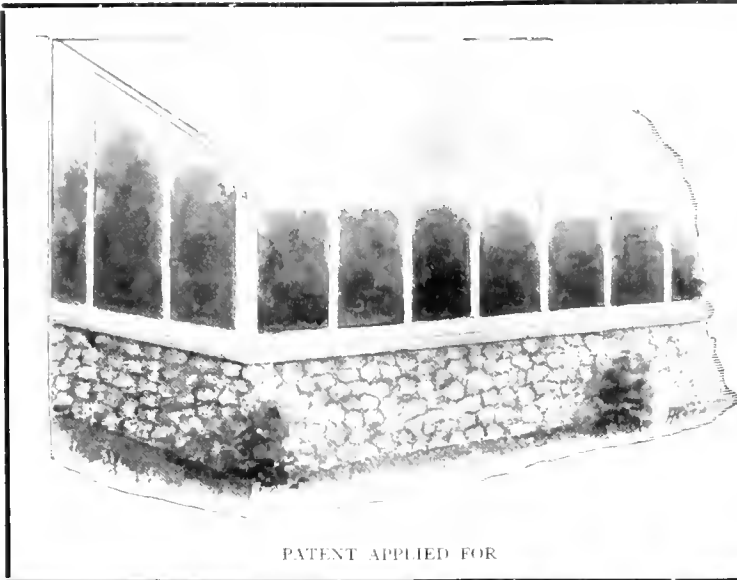

Why My New Curved Iceless Eave is Far Superior to Anything on the Market Today

- 1st. No sash bars incased in iron, thereby eliminating all danger of bars decaying.
- 2nd Can be used in conjunction with iron frame construction, thereby doing away with that very objectionable feature, "columns."
- 3rd. Roof bars with drip grooves, which act as conductors to carry away the condensation: **Result**, the driest roof ever used for greenhouse purposes.
- 4th. **THE MOST IMPORTANT OF THEM ALL.** The very small increase in cost over the ordinary style of construction which makes it possible to be used for commercial as well as private purposes.

William H. Lutton, Horticultural Architect and Builder
West Side Ave Station (C.R.R. of N.J.) Jersey City, N.J.

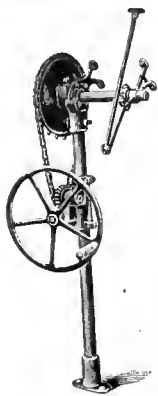

The Advance Ventilating Apparatus

"Your machine is the best we have ever used" is what an Ohio florist writes us in referring to his machine. It is not good only in one part but it is the best in all parts—the results of experience, of careful study, of mechanical construction, best material and backed by moderate prices that makes our line so popular. Give us a trial.

The Advance Co.
RICHMOND, IND.

IRON PIPE

SECOND HAND

WROUGHT IRON PIPE, for Steam, Water, Gas or Oil, Fences or Posts. All Sizes. Price Low.

GEO. B. DOANE & SON
18 Midway Street, BOSTON
Telephone, Main 4419



Evans 20th Century Arm

Will not twist your shafting pipe. Give it a trial and you will use no other. Three times the power of elbow arms.

Write for Catalogue
QUAKER CITY MACHINE CO.
Richmond, Ind.

Holds Glass Firmly
See the Point
PEERLESS

FULL SIZE
No. 2

Glazing Points are the best. No rights or lefts. Box of 1,000 points 75 cts. postpaid.
HENRY A. DEER,
714 Chestnut St., Phila., Pa.

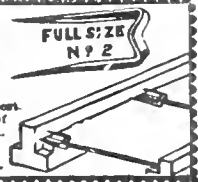

The **FLORISTS' HALL ASSOCIATION OF AMERICA**, insurer of 29,000,000 sq. ft. of glass. For particulars address **John C. Esler, Sec'y, Saddle River, N.J.**

THE FOLEY MFG. CO.

CHICAGO

Completely equipped with up-to-date machinery for the making of material for

GREENHOUSE CONSTRUCTION

From a Full Supply of Thoroughly Seasoned Lumber

Send your sketches to our draughtsmen for completion and suggestion. Permit us to figure your proposed work, large or small.

We guarantee our prices will save you money

FOLEY VENTILATING APPARATUS IS THE BEST

Simple in Erecting Easiest of Operation. It Will Last a Lifetime. Its Price is the Lowest. Will Ventilate Any Size House. Prices and Circulars on Application.

Our 1908 Catalogue Greenhouse Material Sent Postpaid on Request.

THE FOLEY MFG. CO., WESTERN AVENUE 25th and 26th STS., CHICAGO

CYPRESS SASH BARS 82 feet or longer
HOT BED SASH
PECKY CYPRESS BENCH LUMBER

GREENHOUSES

ERECTED AND EQUIPPED COMPLETE IF DESIRED

Write for Circular "D" and Prices

The A. T. STEARNS LUMBER CO.
NEPONSET, BOSTON, MASS.

In ordering goods please add "I saw it in HORTICULTURE."

I. CASSIDY
Designer and Builder of

Iron and Wood Greenhouses
Factory: Summer Ave and Erie R. R.
Newark, N. J.

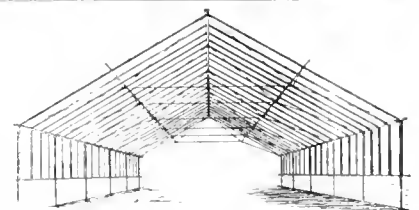

King Greenhouses

Trussed Roofs King Gutter and Eaves, Ventilating Machinery Trussed Iron-frame Houses Tile Benches and Pipe Hangers. Everything for greenhouse building.

Write for Information and Prices.

King Construction Company
North Tonawanda, N. Y.

MASTICA

FOR Greenhouse Glazing

USE IT NOW.

F. O. PIERCE CO.

12 W. Broadway and
227 Greenwich St.
NEW YORK



THE HOUSE OF GREATEST SUNLIGHT

LIGHTEST INTERIOR in the WORLD
THIS HOUSE IS 33 1/2 FEET WIDE
Note: No Columns

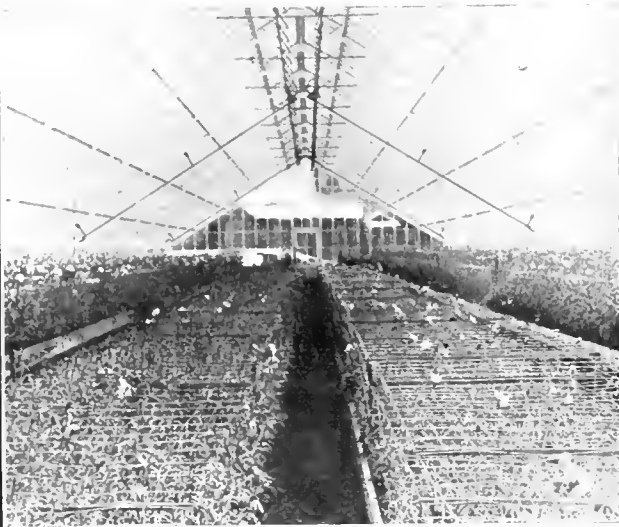

Erected for J. J. BROZAT, Bloomfield, N. J.

BY THE

WEATHERED COMPANY

IRON FRAME, SEMI-IRON FRAME, OR ALL SASH BAR HOUSES, ERECTED OR MATERIAL ONLY

... SEND FOR CATALOGUE ...

P. O. Address Box 789 NEW YORK CITY, N. Y.

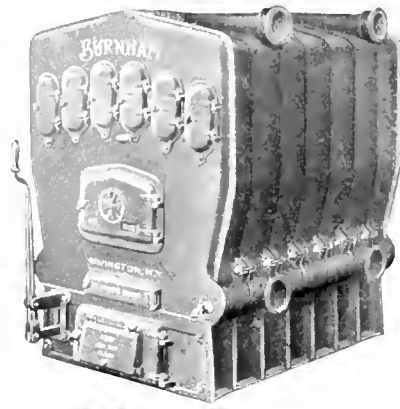

THE BEST JUDGE

West Whiteland P. O.

Chester Co., Pa., May 5, 1908.

In 1896 I built my first greenhouse, and every year have made some addition to the business, until now we have over fifty thousand feet of glass.

Those who have built their business in this way, from the old frame up, usually are in the best position to judge the merits of a boiler. I can, therefore, say the two boilers you installed for us in 1904, have been most satisfactory. We gladly recommend your work.

Yours very truly,

J. L. MAULL,

Millbrook Lea Greenhouse Co.
Whitford Station, Pa.

SEND FOR NEW BOILER CATALOGUE

LORD & BURNHAM CO.

MAIN SALES OFFICE:

1133 BROADWAY, NEW YORK

BOSTON:

819 Tremont Building

PHILADELPHIA:

1215 Filbert St.

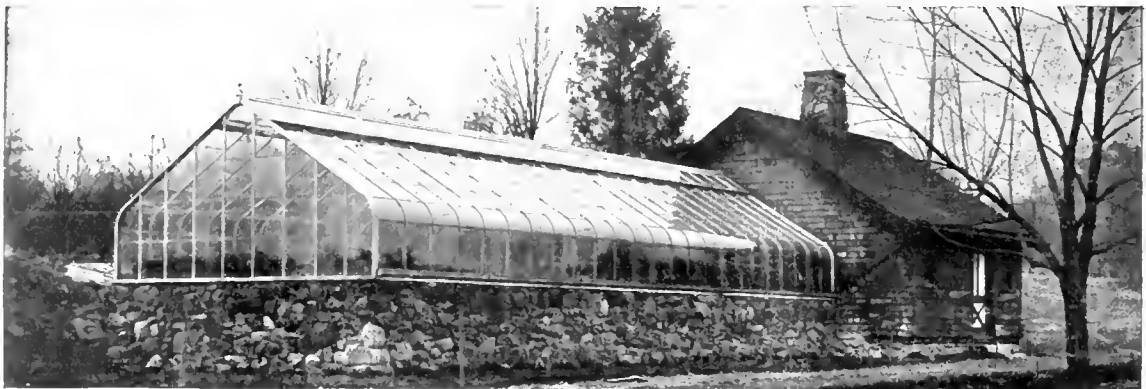

THEY HAVE NO GUTTER AT EAVES

which greatly increases their attractiveness, and decreases the shade. One means a constant satisfaction, the other, unequalled productive ness. They are the lightest, simplest, strongest and most durable houses, and cost less to maintain. Send for catalog.

The ideal construction for private estates, parks, public institutions and florists' showrooms

U-BAR GREENHOUSES

PIERSON

DESIGNERS AND BUILDERS



U-BAR CO.

1 MADISON AVE., NEW YORK

HORTICULTURE

Vol. VII. JUNE 27, 1908 No. 26



Photo. by W. H. Wate.

CROCUSES IN THE GRASS

Devoted to the
**FLORIST, PLANTSMAN,
LANDSCAPE GARDENER,**
and
Kindred Interests

Published
EVERY SATURDAY
At 11 Hamilton Place,
BOSTON, MASS.
Subscription, \$1.00

GERANIUMS

ACCORDIAL INVITATION IS extended to all interested in Geraniums, to visit us in June, to inspect our new stock houses containing over 60,000 plants, and especially our new show houses; in them there are over 300 varieties in full bloom, a splendid opportunity to compare the newer introduction with the Standards, and to select stock for next season. We will make very liberal special prices on all orders booked during June for December delivery. We are at Cowenton on the B. & O. R. R., and at Chase on the Pennsylvania. We meet all trains.

READY FOR SHIPMENT FROM 2-in. POTS

Standard Sorts at \$2.00 per 100 and up. We will send 1000, fifty each of twenty varieties, our selection, for \$18.50, single or double, all good sorts, a splendid collection to stock up on.

Newer Varieties selected from the finest introductions of 1905-6 at \$6.00 to \$8.00 per 100. Novelties, one each of 50 varieties for \$5.00. 1907 introduction from Bruants, Lemoines, Rozain Bouchardat, Cannells, etc.

SMILAX, strong plants, \$2.00 per 100.
 COLEUS, Golden Bedder and Verschaiffeltii, 2 in., \$2.00 per 100.
 3 in., 3.00 per 100.

BEGONIA, Vernon and Gracilis, 2 in., \$2.00 per 100.

HARDY CHRYSANTHEMUMS, \$2.00 per 100. 500 in 20 varieties, our selection for \$9.00. 1000 in 20 varieties our selection for \$17.50, strong plants from 2 in. pots.

R. VINCENT JR. & SONS COMPANY, White Marsh, Md.

COLD STORAGE LILIES

COLD STORAGE LILIES, means that you can have Lilies all the year round. What are more useful, or give more character to the funeral piece than the Lily.

We have, and can deliver at any time cold storage Lilies—and can refer you to hundreds that are growing then, why not you?

LILIUM LONGIFLORUM GIGANTEUM is the only longiflorum that gives satisfaction from cold storage—we offer them as follows:—LILIUM LONGIFLORUM GIGANTEUM (tepacked) 6 to 8 inch bulbs 400 in a case, \$8.50 per 100, \$75.00 per 1000, case of 400 for \$30.00. 7 to 9 inch bulbs, 300 in a case \$9.00 per 100, \$85.00 per 1000, \$25.50 per case of 300. 9 to 10 inch bulbs, 200 in a case, \$14.00 per 100, \$130.00 per 1000, \$26.00 per case of 200.

ARTHUR T. BODDINGTON, Seedsman, 342 WEST 14 TH STREET, NEW YORK CITY

TUBEROSES

EXCELSIOR DWARF PEARL 3 x 4 \$.60 per 100, \$5.00 per 1000
 4 x 6— 1.00 per 100, 8.00 per 1000

STUMPP & WALTER CO., 50 Barclay Street, NEW YORK

A HALF MILLION CALLA BULBS FOR SALE

CALLA ETHIOPICA BULBS, 7 to 8 inch circumference, \$65.00 per 1000
 " " " 5 to 7 " " " 40.00 " " " 3 to 5 " " " 25.00 " " " 250 at 1000 Rates, Freight Prepaid when Cash is sent with Order. Orders booked now for July shipments.

A. MITTING, 17 to 23 Kennan St., Santa Cruz, Cal.

AZALEAS for fall delivery, the best that are grown, also **PALMS** for spring or fall delivery, furnished by Belgium; orders booked now,....
AUGUST HAERENS, Somergem,

AUGUST ROLKER & SONS, 31 Barclay Street, or P. O. Box 752, New York

Established 40 Years

Rose Hill Nurseries

New and Rare Plants

NEW ROCHELLE, N. Y.

New York Office, Siebrecht Building, 425 Fifth Avenue

DAHLIAS. Now is the time to place your order for bulbs which will insure you getting named varieties in any quantity; prompt delivery.

DAVID HERBERT & SON,
 Successors to L. K. Peacock, Inc.
ATCO, N. J.

COLEUS

Verschaiffeltii, Golden Queen, Fire Brand, Lord Palmerston, Queen Victoria, Beckwith's Gem. Prices of Rooted Cuttings by express, 60c. per 100; \$5 per 1000. Less than 250 of a variety will be charged at the 100 rate.

Golden Bedder, Hero, Nessey, Pearl of Orange. 75c. per 100; \$6 per 1000. Less than 250 of a variety will be charged at the 100 rate.

Fancy Varieties. A very fine assortment of twelve kinds not listed above. 75c. per 100; \$6 per 1000. 250, in assortment, our selection, at the 1000 rate.

MISCELLANEOUS PLANTS

AGERATUM, Stella Gurney, Princess Pauline. SALVIA Splendens, Bonfire. HELIOTROPE. Rooted cuttings, 75c. per 100; \$6 per 1000.

CARNATIONS

Rooted Cuttings	100	1000
Winsor.....	\$6.00	\$50.00
White Perfection.....	2.50	20.00
Rose Pink Enchantress.....	3.50	30.00
Enchantress.....	2.50	20.00
Queen Louise.....	2.50	20.00

From 2 1/4 inch pots, add \$1.00 per 100.

ASPARAGUS PLUMOSUS NANUS SEEDLINGS
 From flats, \$1.00 per 1000.

CHRYSANTHEMUMS

Standard varieties, ready for shipment. Rooted cuttings, \$2 per 100; \$15 per 1000. Send for list.

A. N. PIERSON, CROMWELL, CONN.

Surplus Plants

	Per 100
300 Salvia Splendens, 4 in. -	\$5.00
1500 " " 3 in. -	3.00
150 Ageratum, 2 1/2 in. -	1.50
500 Alyssum, Carpet of Snow, 2 1/2 in. -	2.50
750 Alternanthera, red, 2 in. -	2.00
650 " yellow, 2 in. -	2.00
100 Cuphea, 3 in. -	2.00
200 Verbenas, 2 1/2 in. -	1.50
300 Canna (Chas. Henderson) -	5.00
300 " (Florence Vaughan) -	5.00
1000 Geraniums (mostly S.A.Nuti) 3 in. -	3.50
1000 " " 4 in. -	7.00
1500 Madam Salleroi, 3 in. -	3.00

VERN L. SCHLURAFF
ERIE, PA.

Bedding Plants

All Kinds, Stocky, Good Size, Low Price. Can supply the Trade in quantity.

Just Received

A big shipment of ARAUCARIAS, PALMS, etc. Orders taken now for import for fall delivery.

A LEUTHY & CO.
PERKINS ST. NURSERIES
ROSLINDALE, MASS.

Gloire de Lorraine Begonia
 2 1/4 inch pots, \$15.00 per 100
 \$140.00 per 1000

Thomas Roland,
Nahant, Mass.

Begonia Gloire de Lorraine

Strong 2 1/2 in. pot plants, leaf cuttings, \$15 per 100, \$140 per 1000. Early June delivery or NOW if wanted.

S. S. SKIDELSKY, 1741 No. 18th St. PHILADELPHIA

In ordering goods please add "I saw it in HORTICULTURE."

CANNAS

STARTED PLANTS in 3 1/2 and 4-in. POTS READY FOR IMMEDIATE PLANTING

Mme. Nardy, Mile. Berat, Robert Christie, Golden King, Pennsylvania, L. Patry, Florence Vaughan, P. Indora, Austria, Rohallion, Pierson's Premier, Queen Charlotte, Frederick Benary, etc.

EXTRA STRONG PLANTS, \$6.00 PER 100

VINCAS AND ENGLISH IVIES Extra fine plants in 3 1/2 and 4 inch pots, for vases, tubs, etc. \$8.00 per 100; extra size, \$10.00 per 100.

HYDRANGEA OTAKSA LARGE PLANTS IN TUBS AND HALF-BARRELS FOR JULY AND AUGUST FLOWERING. We make a specialty of these, and have a magnificent lot of large plants, which we can supply in any quantity— from single plants up to carload lots. Large plants in tubs, \$2.00 and \$3.00 each. Extra large plants in half-barrels, \$5.00 and \$7.50 each.

NASTURTIUMS. Bushy plants, 3 inch pots, \$6.00 per 100.
SALVIAS, Bon Fire. 2 1/4 inch pots, \$4.00 per 100.
AGERATUM. 2 1/2 inch pots, \$3.00 per 100.
MOON FLOWERS. 2 1/2 inch pots, \$6.00 per 100.
COLEUS, assorted. 2 1/2 inch pots, \$3.00 per 100.
ALYSSUM, Tom Thumb. 2 1/4 inch pots, \$3.00 per 100.
CROTONS, for bedding. Extra strong plants, 3 1/2 inch pots, \$25.00 per 100; 5 inch pots, \$50.00 per 100.
ACALYPHA MUSAICA. Extra choice, for bedding. 2 1/2 inch pots, \$6.00 per 100.
PANDANUS VEITCHII. 5 inch pots, \$9.00 per dozen; 6 inch pots, \$12.00 per dozen; large plants, \$2.00 to \$3.50 each, according to size.
FIGUS ELASTICA. 5 inch pots, \$4.00 per doz; 6 inch pots, \$6.00 per doz.

DRACENA FRAGRANS. Extra large plants, 6 inch pots, 3 feet high, \$12.00 per dozen.
FERNS, assorted. Extra heavy plants, 2 1/4 inch pots, \$3.00 per 100; 3 1/2 inch pots, extra heavy, \$10.00 per 100.
NEPHROLEPIS PIERSONI ELEGANTISSIMA. 2 1/4 inch pots, \$6.00 per 100; 3 1/2 inch pots, \$15.00 per 100; 6 inch pots, \$6.00 per dozen; 8 inch pots, \$12.00 per dozen.
BOXWOOD, Pyramids. Extra fine plants, \$2.00 and \$3.00 each.
PANSIES, ENGLISH DAISIES, and FORGET-ME-NOTS. \$3.00 per 100.
CARNATIONS, Winsor and White Enchantress. We can supply these in quantity, ready for immediate planting. Strong established plants from 2 1/4 inch pots, \$7.50 per 100. \$60.00 per 1000.

F. R. PIERSON CO., Tarrytown-on-Hudson, New York

Grab These BARGAINS

Moonvines, best White, 4-in. 12 cents, 2 1/2-in. 5 cents.
 Scarlet Sage, Clara Bedman or Bonfire, 4-in. strong, \$5.00 per 100; \$45.00 per 1000.
 Clematis Jackmanni, late fall importation, 3 ft. high, nicely staked up, 35 to 40c.
 Araucaria Excelsa Glauca, 6 to 7-in. pots, last spring (1907) importation, 5 tiers, 25 to 40 inches high, same in width, 6 year old, suitable for lawns and porches, \$1.75, \$2.00, \$2.50, \$3.00, \$4.00 each. Imported two weeks ago 5000 Araucaria Excelsa, 3 tiers, 6-8-10-in. high, 40c; 10-12-14-in., 50c, 60c, 75c, \$1.00 each.
 Kentia Belmoreana, 6-in., 75c, \$1.00, \$1.25, \$2.00; 5 1/2-in., 20-25 inches high, 50c, 60c; 4 in., 35c. Forsteriana, large plants, \$2.50 each. 7-in., 40-50 inches high, \$3.00.
 Bay Trees, just arrived from Europe, Standard, 8-ft. high from top of tub, crown 30 inches in diameter, per pr., \$15.00.

Cash with order, please. All goods must travel at purchaser's risk

Godfrey Aschmann

Importer, Wholesale Grower and Shipper of Pot Plants

1012 West Ontario St. Philadelphia, Pa.

Asparagus plumosus naous, Sprengerii, 3 in. \$3.00 per 100.
Aspidistra, excellent plants, 5 in. pots, green \$4.00 per doz., variegated, \$15.00 per doz.
Araucaria excelsa, \$25.00 per 100 upwards.
Adiantum cuneatum, 3 in., \$3.00 per 100.
Ficus elastica (Rubbers) 5 in. \$20.00 per 100.
Dracena indivisa, \$4.00 to \$25.00 per 100.
 " Sanderii, 3 in., \$15.00 per 100.
 " Goldfiana, 3 in., \$6.00 per 100.
Cocos Weddelliana, 3 in., \$10.00 per 100.
Latania Borbonica, \$5.00 per 100 upwards.
Kentia Forsteriana and Belmoreana, \$1.00 per 100 up to \$10.00 each.
Smilax, 3 in., \$2.50 per 100.
Poinsettia, 3 in., \$6.00 per 100.
Nephrolepis Scotti, Piersoni, 3 in., \$5.00 per 100.
 " Bostoniensis, 3 in., \$3.00 per 100.
 Absolute Satisfaction Guaranteed.

M. H. ROSE, 46 Macomb Street, Detroit, Mich.

BAY STATE

The big sensation of all the recent Carnation Shows. A noble flower, white with carmine markings.

Now Booking Orders for Next January Delivery.

Rooted Cuttings, \$12.00 per 100, \$100.00 per 1000
ALBERT ROPER, Tewkesbury, Mass.

ROSES

Well rooted 3 in., ready for shipment—

Uncle John, Chatenay, Golden Gate, Ivory Bridesmaid and Bride

\$4.00 per 100, \$35.00 per 1000.

Dracaena indivisa, fine thrifty stock in 3 in. \$5.00 per 100. Special price by the 1000.

Hydrangea Otaksa, 2 1/2 in. \$2.50 per 100, \$21.00 per 1000.

Vinca variegata, heavy, splendid color, 3 in. \$6.00 per 100, 4 in. \$8.00 per 100.

JOHN C. HATCHER AMSTERDAM, N. Y.

Stores (Schenectady and Green-Town of Florida houses and Hoffmans

Look through the Buyers' Directory and Ready Reference Guide. You will find some good offers there also.

HYACINTHS, TULIPS, NARCISSI AND OTHER BULBS

ROMAN HYACINTHS and the true PAPER WHITE GRANDIFLORA

Ask for our Wholesale Trade List at Hillegom

K. VELTHUYS, Hillegom, Holland
 Rep. by FELIX BOSCH, 260 Clarendon St., Boston.

CARNATIONS

F. DORNER & SONS CO.
 La Fayette, Ind.

BEST VARIETIES
 Field-grown

CARNATION PLANTS
 CHICAGO CARNATION CO.

A. T. PYFER, MGR. JOLIET, ILL.

JOHN E. HAINES
 Bethlehem, Pa.

Field plants of the following varieties will be ready by August 1st.

John E. Haines, red Imperial variegated Pink Imperial, Pink Enchantress, Light Pink } Per 100 Per 1000
 \$6.00 \$50.00
 Place your orders early for Jan. delivery.

JAPANESE

THE YOKOHAMA NURSERY CO.
 31 BARCLAY STR. NEW YORK.

LILIES

PLANTS
 BAMBOO STAKES

Prices Quoted in these Columns are for Dealers Only. When Writing to Advertisers Please Mention HORTICULTURE.

ROSES

100 of the best Hardy sorts.

HYBRID PERPETUALS

Finest English Grown Plants

Dozen, \$3 50; 100 \$25.00

EVERBLOOMING HYBRID TEAS

Bloom from Midsummer until frost.

Dozen \$5.00; 100, \$35 00

Hardy Climbing Roses

All the leading sorts.

Catalogue Free on Application.

R. & J. FARQUHAR & CO.

6 and 7 So. Market Street,
Boston, Mass.

ROSES OWN ROOTS

Strong, healthy stock, propagated from grafted plants. We must dispose of these at once to make room for planting.

Brides, Maids, Killarney, Richmond
\$4.00 per 100; \$35.00 per M.

Grafted Killarney, 3 in., strong stock, at \$12 \$100
Mme. Chatenay, own root, 4 in., extra fine 5 45

S. J. RUETER & SON
WESTERLY, R. I.

ROSES

Strong, Clean Stock. Grafted, Killarney, Richmond, Brides and Maids. \$12.00 per 100, \$110.00 per 1000. Own Roots, Brides, Maids, Gates, Ivory, Perle, Killarney and Richmond. \$6.00 per 100, \$55 per 1000. All from 3 1/2 in. pots.

P. R. QUINLAN, Syracuse, N. Y.
Hardy Rhododendrons, Azaleas Conifers, Clematis, H. P. Roses, Shrubs and Herbaceous Plants from our HOLLAND NURSERIES

Prices Moderate
P. OUWERKERK, 216 Jane St., Weehawken Heights, N. J.

In ordering goods please add "I saw it in HORTICULTURE."

ROBERT CRAIG CO.

ROSES, PALMS,

and Novelties in Decorative Plants
MARKET and 49th STREETS., PHILADELPHIA, PA.

PALMS Home Grown.

KENTIA BELMOREANA

	Each	Doz.
6-in. pot, 6 to 7 leaves, 22 to 24 in.	\$1.50	\$12.00
6-in. pot, 6 to 7 leaves, 24 to 26 in.	1.75	15.00
6 in. pot, 6 to 7 leaves, 26 to 28 in.	1.50	12.00
6 in. pot, 6 to 7 leaves, 30 to 36 in.	2.00	14.00
7-in. pot, 6 to 7 leaves, 32 to 34 in. heavy	2.50	20.00

COCOS WEDDELIANA

2 1/2 in. pot, 8 to 11 in. high	10 cents each
2 1/2 in. pot, 11 to 12 in. high	15 cents each

A FULL LINE OF KENTIAS

All Sizes) READY IN JULY

JOSEPH HEACOCK COMPANY, Wyncote, Pa.

RHODODENDRONS, ANDROMEDAS, KALMIAS AND SPECIMEN EVERGREENS

JOHN WATERER & SONS, LD.

AMERICAN NURSERY

BAGSHOT, - - - ENGLAND

FINEST LOT OF

HARDY HYBRID RHODODENDRONS

ALSO DWARF RHODODENDRONS
ANDROMEDA FLORIBUNDA

READY FOR IMMEDIATE SHIPMENT

ORDER TODAY

EASTERN NURSERIES, JAMAICA PLAIN, MASS.

HARDY NORTHERN GROWN NURSERY STOCK

At Reasonable Prices

FRUIT AND ORNAMENTAL TREES, SHRUBS, VINES, ROSES AND HERBACEOUS PERENNIALS IN GREAT VARIETY

Catalogue and Price List for the asking

BAY STATE NURSERIES, NORTH ABINGTON, MASS.

The Roses that Win

MRS. POTTER PALMER, CARDINAL American Beauty and Other Standard Varieties. Rooted from Our Famous Stock. Send for Prices.

POEHLMANN BROS. CO.
Morton Grove, Ill.

THE E. G. HILL CO.,

Richmond, Indiana

are now booking orders for splendid one year transplanted clumps of PEONIES the very finest varieties only, in perfect condition and at reasonable prices. We have not one poor variety in our entire collection but selected commercial sorts from the best of European and American varieties. Send for our price list.

AMERICAN NURSERY CO., COMBINING

FRED W. KELSEY, New York City
F. & F. NURSERIES, Springfield, N. J.
BLOODGOOD NURSERIES, Flushing, L. I.
N. J. & L. I. NURSERIES

We can supply you every need. Write for prices
Sales Department
150 BROADWAY, - NEW YORK

ROSES

A SPECIALTY

The Dingee & Conard Co. West Grove PA.

In writing to Advertisers kindly mention Horticulture

Notes from the Arnold Arboretum

One of the finest of the native Arrow-roots is *Viburnum venosum* which forms a broad round shrub from six to twelve feet in height now covered with numerous showy white flower clusters. Still handsomer is its variety *V. venosum* var. *Canbyi* which has darker green and larger leaves and somewhat larger flower clusters; it flowers somewhat later and is a native of Pennsylvania, while the true *V. venosum* grows along the coast from Massachusetts to New Jersey. Both these Arrow-roots were passing formerly together with a southern species, *V. scabrellum*, under the name *V. molle* mentioned in the last issue as a shrub but recently introduced into cultivation and still little known. In habit and general appearance *V. venosum* and its variety are much like *V. pubescens* and *V. dentatum* and like those very desirable shrubs particularly for borders of shrubberies with their compact habit, clean foliage not liable to injury by insects and fungi and assuming a handsome fall coloring and with their showy flowers followed in autumn by attractive bluish black fruits. Though almost alike in their ornamental qualities these Arrow-roots differ in the time of flowering and therefore are all equally desirable; the first is *V. pubescens*, about two weeks after it *V. dentatum* begins to bloom and a week later *V. venosum* closely followed by its variety *Canbyi*.

Another shrub now made attractive by its white flower cluster similar to those of the Arrow-roots is *Cornus obliqua* (*C. Purpusii*) formerly confounded with *V. Amomum* from which it differs in its looser habit and narrower and smaller leaves whitish beneath; it flowers a little in advance and more profusely. An interesting and handsome hybrid of *C. obliqua* and the graceful *C. paniculata* is *C. Arnoldiana* in habit much like *C. paniculata*, but forming a larger and more compact shrub and therefore of more than botanical interest; it originated at the Arboretum.

A common native shrub but nevertheless of much ornamental value in suitable places particularly on the borders of ponds and water courses is the Sweet Elder, *Sambucus canadensis*, which is a very effective shrub when covered with its large clusters of white flowers followed later by purplish black berries. A variety of this species with finely dissected leaves, *S. canadensis* var. *acutifolia*, is highly ornamental on account of its light and airy appearance and is to be counted as one of the best cut-leaved shrubs; it is certainly handsomer than *S. nigra* var. *laciniata*. It has been but recently introduced into cultivation and is still little known.

The latest of the Hawthorns to bloom is the Washington Thorn, *Crataegus cordata* or *C. Phacopyrum*, which must be classed as one of the most ornamental of the whole genus. It is a small tree with handsome lustrous foliage changing in autumn to brilliant colors and with abundant white flowers followed in autumn by glossy bright red fruits remaining on the tree late into the winter. Not the least of its good points is its apparent immunity from the leaf-miner disfiguring our Hawthorne so much in spring when they would be such beautiful objects with their wealth of white flowers and delicate young foliage.

Magnolia macrophylla is now adorned with its big white flower by far the largest of any North American tree. It is certainly a highly ornamental tree even when not in bloom on account of its large leaves which give to it an almost tropical appearance; unfortunately it is not perfectly hardy in this section of the country at least while young, when it needs some slight protection.

Older trees, however, stand even severe winters quite well in eastern Massachusetts. Also the shrubby *M. glauca* shows now its handsome white cup-shaped flowers.

A pretty little low shrub particularly adapted for rockeries and gravelly slopes is *Cytisus albus* var. *schipkaensis* forming a dense prostrate shrub covered with numerous heads of white flowers, a color rare in the genus *Cytisus*. An ally of it *Genista tinctoria* is now beginning to show its spikes of bright yellow flowers; it is a low upright shrub well adapted for covering dry slopes and perfectly hardy, in fact it has become naturalized in many places of similar description in the northeastern states. Another handsome low Leguminous shrub for rockeries is *Calophaea vulgarica* with deep yellow flowers in short racemes; it is sometimes grafted high on *Caragana* and forming then very attractive small standard trees.

As one of the few Maples with ornamental fruits *Acer tataricum* merits to be noted; it is a handsome small shrubby tree now very attractive with its light red fruits.

Alfred Rehder.

Arnold Arboretum, Jamaica Plain, Mass.

British Horticulture

A RHODODENDRON SHOW

According to their usual custom, Messrs. John Waterer & Sons are this month making a brilliant display of rhododendrons in an immense marquee erected in the Royal Botanic Gardens. The collection includes the leading varieties which Messrs. Waterer have brought to the front, and these are of meritorious standard of culture. A grand effort is produced with the grouping of the various gay tints on the undulating ground beneath the canvas, and one is impressed with the great value of the rhododendron for producing a bold display when judiciously arranged. This notable event in the London season has done a great deal in popularizing the rhododendron. Messrs. Waterer for some years have made a specialty of rhododendrons, a large acreage being devoted to their cultivation at their American Nurseries at Bagshot. A large number of the leading named sorts have been raised by the firm, for which the demand is well maintained, orders being received from all parts of the world. In the course of an interview sometime ago, one of the members of the firm said, "Exclusive of the little seedlings, we send out from 50,000 to 100,000 rhododendrons each year. Sometimes, as only the other day, we have a retail order for 2,000 of one variety. These are all named varieties, propagated by grafting and layering—by layering as much as possible." The nursery is also noted for its hollies and yews and shrubs which are also supplied in large quantities.

A NEW TOMATO DISEASE

The tomato crop in some parts has recently been found to be attacked by a disease which has not previously been known to exist in this country, according to Mr. H. T. Gussow, who contributes an article to the Board of Agriculture Journal. The disease, it is stated, was first reported from South America, the native country of the tomato. From its sudden appearance in Britain it is assumed that the fungus has been introduced from abroad with imported tomatoes. A crop of outdoor tomatoes in Gloucestershire was entirely

destroyed last year by the disease. The fungus which causes the disease is closely related to the "leaf spot" disease in strawberries, apples, pears, and chrysanthemums, but is quite distinct from any of these diseases. It has been proved that spores of the fungi causing "leaf spot" on the plants before mentioned are incapable of producing this particular disease on tomatoes. In the same way experiments made with the object of infecting potatoes and other plants with spores from this tomato fungus have not resulted in any injury. The tomato plants attacked show small blackish green spots on the leaves. These are irregular in shape at first, but soon become concentric and finally confluent, and the leaves, which are rapidly killed, roll up and hang loosely from the stalk. The fungus also attacks the stem, the calyx, and finally the fruit itself. From experiments made, it has been demonstrated that plants once attacked can only be saved by spraying immediately when the first signs of disease are noticed. The plants should be sprayed with a 3 per cent. solution of Bordeaux mixture early in the morning every second day for two weeks. The spray should be in the form of a fine vapor falling upon the plants like a natural dew. It is recommended that tomato seed from infected areas should not be used, but if so should be steeped for one hour in a 5 per cent. solution of copper sulphate and dried before sowing.

THE POWER OF UNITY

A satisfactory report of progress and prospects was presented at the annual meeting of the British Gardeners' Association, which has been formed to improve the status of the working gardener. The chairman (Mr. Chas. Foster) stated that the Association has attained a membership of 1,200 in four years. Few societies connected with horticulture had ever made so rapid an advance in such a brief period. At the previous council meeting no fewer than 78 new members had been elected. The Association journal was doing excellent work as a monthly publication, and helping materially to bring the provincial members more closely in touch with one another. The improved education of gardeners was receiving earnest attention, and a provisional scheme for examinations had been set forth, which it was intended to carry out in such a modified form as further consideration and discussion might render necessary. The Association is likely to occupy a useful part in protecting the interests of the working members, besides preventing employers being imposed upon by men who have no claim to call themselves gardeners.

A PLEASANT OUTING

The members of the council and committees of the Royal Horticultural Society recently spent an enjoyable day in visiting the Windsor Castle and Frogmore gardens, by permission of King Edward. The visitors were entertained at luncheon by the Mayor of Windsor, who was suitably thanked on behalf of the guests by Sir Trevor Lawrence, the president of the society. In the afternoon the conservatories and gardens were visited under the direction of A. MacKellar, head gardener at Frogmore, and there was much to praise in the well arranged and admirably kept establishment. The display of roses was particularly fine.

W. G. H. Aclsett.

About Some Peonies

On the whole, in this vicinity (Chicago) the crop of flowers is considered above the average and satisfactory. Yet some varieties have not given a solitary flower. In rows of four kinds, 25 of each, exposed to the same conditions of culture established in their positions for four years (the beau ideal of a peony plant's life is then established) we note that there are many varieties without a bloom, or, perhaps a few that have a crippled flower or two.

The question is—are peonies becoming whimsical? Do they have their on years and their off years? In a general way and without any favoritism where one variety doesn't get any more to drink than its neighbor, one would think there would be a general showing. Let's think a bit. No doubt it is a fact that there is a period in a peony plant when its plans are laid for another year and that it goes through many vicissitudes each season. If the rule held good that a plant bearing a large crop of flowers one year does not bear a large crop next year one could reason the matter out, but this is not so. Varieties will continue in their even tenor of flowering for three or four seasons; then all at once there is a failure which is general and not attributable to frost causes after the growth has commenced in spring. One is asked, "How is your Dr. Bretonneau flowering this year? I have not a single flower." "Neither have I." "Nor a flower on M. Bouchardat Aime." It's worth considering why.

ABOUT VARIETIES GENERALLY

Blood red, deep crimson, amaranth and deep maroon peonies are not nearly as much appreciated as they should be. (I leave the commercial cut flower element out of this entirely and under no consideration would I ask the opinion of those who only talk long stems, good snippers, and about a 3-color limit.) It is for garden decoration I am advocating these positively decided, effective colorings; they have no equals; they are in proper positions wherever placed; the white spiraeas and the snowy philadelphus nod their plumes to all peonies but particularly to the deep-colored brigade.

I have rather digressed from my original intention, as I thought I would simply send a list of the very finest and true to name varieties I saw at the Peterson nurseries, Chicago. Undoubtedly the Peterson collection is one of the very best in the country, and if there is a collection where more time, care, money, disappointment, cursing and ultimate satisfaction have been spent and obtained "it's next." I was shown a record of one supposed variety from twenty different sources in which there were actually sixteen kinds—enough for a distinct collection, and that's not so long ago. Peterson's finest reds are:

M. Martin Calizac, deepest crimson velvet maroon—

the most impressive of all dark flowers I have ever seen: Augustin d'Hour, deep red; M. du Ribert, brilliant red; Armandine Mechin, deep crimson on red; Delachéfi, deep amaranth, very old and very good; Adolph Rosseau, amaranth; François Ortegal, very dark; Souvenir de l'Exposition de Universelle, clear red, another good old one; Rubra Triumphans, another of the old guard; Emile Lemoine, deep red; Richardson's Rubra Superba, very dark, late; Felix Crousse, red, distinct and worthy of the name. Other good reds are Henri Demay, violet purple; Jussieu, black purple; Louis Van Houtte, crimson; Calot's Louis Van Houtte, cherry red; Prince Talindyke, purple crimson; Ville de Nancy, brilliant crimson and *Violacea Superba*, deep violet purple.

Rose color peonies, good color: Modeste Guerin, bright rose; Mme. Forel, deep rose; M. Krelage, deep rose; *Edulis Superba*, well named; M. Boucharlataine, bright color.

Pink peonies, all good: Triumphe de l'Exposition de Lille, peach pink; Delicatissima, chaste, old and good; Dr. Bretonneau, clear color; Albert Crousse, light pink; General Bedeau, pink shaded lavender, unique; Jenny Lind, salmon pink; Mme. C. Bancel, deep color; Pottsi Alba, an old gem; *Grandiflora Carnea*, flesh white.

White peonies, and their next of kin: Whitleyi; I wonder how many cognomens this superb variety has been afflicted with: it's the oldest and one of the very best; Festiva Maxima, finest in its class; Alba Sulfurea, very early; Madame Crousse, a gem; M. Dupont, large, fine late; Couronne d'Or, a fine late variety; la Tulipe, blush and red markings; Mad. de Verneville, pure white, flaked red, fragrant, early; Marie Lemoine, large, late; Duchesse de Nemours, pure white, very fragrant late; Charlemagne, flesh white; Bernard Palissy, blush; Virgo Marie, pure white, one of the best; and dear old Albiflora, the mother of so many.

In a class which is undefined there are varieties of decidedly different coloration: for instance, Golden Harvest is classed among the white with this description—blush guard, collar clear yellow, centre white with carmine stripes and tips. Apropos of Golden Harvest, among ten varieties of the very best the question was asked, which of the ten is the best? This was asked at seven different points. Mr. A. Loeffler, an enthusiastic amateur, picked Golden Harvest. An artist of repute in Chicago did the same; so did three others. My opinion of Golden Harvest is that it is a gem of the first water and is one of the most beautiful of all garden peonies; it is dwarf, free, well furnished with foliage and is not affected by the wind. Add M. Boucharlataine, white and yellow; Solfaterre, very beautiful, blush and lemon.

A Test of Peonies

What we want is plants that will stand everything without being discouraged—those that will be prolific and sure bloomers.

We had the most remarkable spring on record. April and May changed places and the mischief was to pay. Warm days brought out the buds and it seemed as if we would have flowers in a few days. Then early in May, we had a succession, not of frosts but of freezes which froze the ground. It was a fearful test. Then came mild days to encourage them. Many recovered and we thought they would be all right. Then a bitter cruel freeze sneaked in and caught everything unawares and we asked, Can any living thing endure this? Our old favorites gave it up. Of one thousand Festiva Maximas not a dozen decent blooms. The faithful L'Esperance, our dependence for Decoration Day, gave up the struggle. Calls poured in, but most of the peonies were nipped in the bud. Yet there were some that just gloried in tribulation and paid no attention whatever to little trials like those. Golden Harvest maintained her never-fail reputation and ought to stand away at the front—hardy everywhere in Manitoba and the Dakotas. The plants covered with flowers of exquisite beauty. They need but a strong and long stem to stamp them as perfect. Charles Verdier was a glory of bloom. Faust, M. Jules Elie, Sarah Bernhardt, and Louis Van Houtte answered the roll call promptly. I was surprised at the vigor of the M. Duponts. They were by far the best and grandest of the whites—splendid, solid hemispheres, seven inches across, centers flecked with carmine, so distinctly marked you could not mistake them. La Subline, literally deluged the plants with crimson beauty. Couronne d'Or never did better. Baroness Schroeder sent out a flower for every stem. One thousand Queen Victorias, usually so hardy, gave up in disgust; not a decent flower on the whole mass. Rosenfield's Triumphs, bred for hardiness and beauty, carefully selected out of thousands, and blooming qualities carefully noted for years before putting them on the market, were on hand promptly. Karl Rosenfield, the ideal crimson and the finest among seven hundred, was all right, arrayed in royal splendor. Ak-sar-ben, brilliant crimson maroon; Grace D. Bryan, splendid large pink; Crimson Victory, radiant in loveliness; Prairie Splendor, with delicious perfume and magnificent bloom, seven inches across, with Prairie King with full globe of brilliant soft violaceous red, all sustained the test. These are very robust, the stems are from forty to forty-eight inches tall. Just what we have been looking for to endure the trying climate of the West.

Jeanne d'Arc and Golden Harvest. As these bloomed this year, it was hard to tell the difference in the flowers. The former is probably the mother of the latter.

There is this difference, a row of Jeanne d'Arc planted last fall did not produce a flower. A row of Golden Harvest planted the same time was covered with bloom.

John Thorpe

C. S. Hamman

HORTICULTURE

VOL. VII JUNE 27, 1908 NO. 26

PUBLISHED WEEKLY BY
HORTICULTURE PUBLISHING CO.
11 Hamilton Place, Boston, Mass.

Telephone, Oxford 292
WM. J. STEWART, Editor and Manager

SUBSCRIPTION PRICE

One Year, in advance, \$1.00; To Foreign Countries, 2.00. To Canada, \$1.50

ADVERTISING RATES

Per Inch, 30 inches to page \$1.00.
Discounts on Contracts for consecutive insertions, as follows:
One month (4 times) 5 per cent., three months (13 times) 10 per cent.;
six months (26 times) 20 per cent., one year (52 times) 30 per cent.
Page and half page spaces, special rates on application.

Entered as second-class matter December 8, 1904, at the Post Office at Boston, Mass., under the Act of Congress of March 3, 1879.

CONTENTS

COVER ILLUSTRATION—Creosenes in the Grass	
NOTES FROM THE ARNOLD ARBORETUM—Meredith Rehder	845
BRITISH HORTICULTURE—W. H. Adsett	845
ABOUT SOME PEONIES—John Thorpe	846
A TEST OF PEONIES—C. S. Harrison	847
A PROTEST	849
CREOSENES IN THE GRASS	849
A SPIKE FROM THE SPICE BUSH—G. C. Watson	849
NEWS OF THE CLUBS AND SOCIETIES:	
Massachusetts Horticultural Society—New Orleans Horticultural Society—New Haven County Horticultural Society—Morris County Gardeners' and Florists' Society—New Bedford Horticultural Society—Pennsylvania Horticultural Society	850
Club and Society Notes	851
DURING RECESS:	
A Waretown Pastoral—New York Florists' Club—Ponies in Prospect—Florists' and Gardeners' Club of Rhode Island, Illustration	851
AMERICAN PEONY SOCIETY:	
Sixth Annual Meeting at Ithaca, N. Y.—Reports—Check List—Frauds—Next Place of Meeting—Election of Officers—Report of the Secretary	852
OBITUARY—The Late Alexander Wallace, Portrait—Emmanuel Hippard—John Cammack	853
CATTLEYA GIGAS SANDERIANA—Illustrated	854
PROPOSED LAW AFFECTING INSECTICIDES—Benj. Hammond	856
SEED TRADE	857
American Seed Trade Association	857
OF INTEREST TO RETAIL FLORISTS:	
Women in Chicago Florist Trade—Steamer Departures—New Retail Flower Stores	858
FLOWER MARKET REPORTS:	
Boston, Buffalo, Chicago, Indianapolis, New York, Philadelphia	861
MISCELLANEOUS:	
The Express Monopoly	849
Freight Rates on Japan Bulbs	849
The Paris Salon	849
Monsieur Abel Chatenay	853
The Alaska-Yukon-Pacific Exposition	854
Ghent Quinquennial Show	854
New Notes	854
Business Changes	855
Detroit Park Board vs. San Jose Sade	856
Personals	859
Personal Items from Madison, N. J.	859
Incorporated	859
On the Alps	861
List of Patents	868
Greenhouses Building or Contemplated	869

of pretentious proportions as planned, it is the duty of every plant, flower, fruit or vegetable grower to contribute in some way towards the success of those at least that are in his immediate neighborhood, this not only from the standpoint of disinterested liberality but also in pursuance of self-interest in a business way. As the basis of all exhibiting must be a desire to excel, preparatory work should be begun as early as possible and one uppermost aim should be to bring forward something sufficiently novel to excite public interest.

The feature of novelty should be made a cardinal point in the preparation of the prize schedule of every show where public interest is sought.

We have dwelt on this subject several times already but it will do no harm to dilate further on its various phases for it is what must, in all such enterprises where expense is assumed, stand between the promoters and disaster. Unless public enthusiasm is made to follow on and supplement professional enthusiasm, the best show in the world from a professional viewpoint, will turn out a flat failure financially. And here a word of caution may not be amiss: novelty is not necessarily oddity and public enthusiasm is something different from mere curiosity. Let it be clearly understood that the public soon tire of the fine cultural distinctions which to the gardener are of such vital concern, but will always be found ready to respond to a practical demonstration of the proper disposal and artistic uses of plants and flowers about the home or for social events in which human interest centres. Without this element a "paying" show is a gamble, with the odds against you.

While on the subject of exhibitions the long-talked-of national flower show is a timely topic. Less than five months away, looms up that stupendous project at Chicago. We believe that, if the growers throughout the country do their best the people in and about Chicago may be depended upon for enthusiastic and substantial support. Much is made of the importance of getting together a big representation of all the horticultural interests and, from the standpoint of the professional horticulturist, the advantage to be gained thus cannot be too strongly urged. The event, if carried out as proposed, cannot but result in a vivifying such as no other single event in American horticultural industry has ever brought about. But of equal or even greater importance is the awakening of the public eagerness and zeal and to this end, our Chicago friends who must, of necessity, take the laboring oar, are entitled to and should have, something more than mere contributions of dozens, hundreds or even thousands of well-grown flowers. If each exhibitor will seriously consider what he can present that will, by its impressiveness or novelty, command special attention from the daily press, the grand result need not be for one moment in doubt.

The fall exhibitors Now that the spring rush days are over and the school graduation and the "June wedding" almost passed into history, it will be in order to give a little thought to the fall exhibitions. Whether these be of modest or

A PROTEST.

We learn from the Worcester daily papers that it is the purpose of the directors of the Art Museum in that city to demolish the conservatories on the estate of their benefactor, the late Stephen Salisbury. Considering that the Museum realizes annually the income from a legacy of \$1,000,000, it does not appear that the contemplated abolition of these greenhouses and their contents is called for on grounds of economy, and we heartily concur in the sentiments expressed by remonstrants against the decision of the Museum directors, and especially against the dismissal of that fine old gardener John Coulson, whose charge these conservatories have been for so many years. Mr. Coulson is a gardener of the highest type, a botanist of no small attainments, and he and the greenhouses under his supervision are well worth to Worcester's citizens all they cost. We believe that if the circumstances could be brought home to the leading horticultural spirits in the land a vigorous appeal would be forthcoming for the preservation of this old landmark so closely identified with the memory of the man who did so much for his city.

CROCUSES IN THE GRASS.

Our cover illustration from a photograph by W. H. Waite, of Greystone, Yonkers, N. Y., shows one of the most beautiful scenes that the eye can rest upon. After the dreary aspects of the winter season, one of the first flowers of spring is the crocus and one may well wonder how it is that a flower of so delicate a texture and such purity of color can make itself at home amidst sleet and cold and the remnants of the winter's snowdrifts. It is not in the window box or the garden border that the crocus is seen at its best, but as shown in the picture, when allowed to run riot, as it were in colonies, with colors massed, in the grass, provided only that it is not disturbed by the spring lawn mower and no cutting is done until the crocus foliage has turned yellow. For best effect crocus bulbs should be planted early—say, September or October at the latest. Many defer crocus planting until November or December, which is a mistake, for many of the bulbs are then liable to winter-kill. Early planted bulbs will make long roots and get ready for a good start at the proper time, and these are rarely injured by freezing or thawing. Medium sized bulbs are the best and less liable to injury at any time than those that are extremely large. They should be planted fully three inches below the surface. Some of the most satisfactory varieties are Golden Yellow, Mammoth White syn. Mont Blanc, Sir Walter Scott, striped, *Purpurea Grandiflora*, and Baron Bruno purple. If planted and treated as above advised, once planted they will continue to bloom and increase indefinitely year after year. Every florist should induce his customers to buy and plant them by the thousand and tens of thousands.

THE EXPRESS MONOPOLY.

Express rates are being looked into with much care by the Interstate Commerce Commission. Their findings so far afford some hope that lower rates may be ordered, although such results are not likely for a long time, perhaps for years, during which time the express monopoly will, no doubt, "make hay while the sun shines," and continue to extort enormous profits from the public.

The commission lays down the view that the company should be satisfied to earn 10 per cent. on the money invested after paying salaries and expenses, and that any profit over such an amount would be reason for ordering a reduction in rates. The companies cannot claim to have very great sums invested in the business. A large part of the dividends they pay is paid upon grossly watered stock. They allowed their profits to heap up, gave them to their stockholders as bonds or stocks, and paid interest on these bonds or stocks which did not cost the owners a cent. The express companies own very little property used in the business. The railroads provide the cars and charge the express companies about half their income for carrying the goods. The express companies own almost nothing except office furniture and wagons for delivering goods in the larger cities. They are middlemen of the most objectionable kind coming between the railroad and the shipper in this way.

There is no reason why the railroads could not carry and deliver the class of goods handled by the express companies, and they could do it at little more than half the cost of the present system. The Interstate Commerce Commission ought to be able to separate the real capital from the capital based on nothing but profits and then adjust the rates to the actual situation. If the companies cannot be abolished and the business turned over to the railroads a fair adjustment of rates will be the next best offer of relief to the public.—*American Cultivator*.

FREIGHT RATES ON JAPAN BULBS.

Since our report of last week was published the Great Northern R. R. informs us that the Interstate Commerce Commission have arranged that the present freight rate on goods from Japan to United States will be continued for a period of three months, from June 30th, which will be until October 1st, after which date a separate rate on the Pacific steamers will be charged, and then the through rate from the coast will be applied. The Interstate Commerce Commission have not yet determined the new through rates, but there is little doubt that they will be high enough to raise the cost of Japanese bulbs considerably.

Edw. Amerpohl, the introducer of *Nephtolepis Amerpohli*, has another new sort which gives promise of being superior to others of this type, and which will, if its good qualities continue, be introduced as soon as sufficient stock can be worked up.

A SPRIG FROM THE SPICE BUSH.

The following is the published report of a recent interview with Mr. Frank H. Traendly, New York:

"The ideas expressed before the Florists' Club of Philadelphia are not new, and to my knowledge have been agitated for many years; in fact, as far back as I can remember the question has been brought up every little while by some one. This matter has been thrashed out so often that I feel that anything I might say would be of little consequence. Philadelphia, as usual, seems to have woke up long after all other cities. It is a condition that we all have to buck against and do the best we can."

The phrase I wish to comment on is, "Philadelphia, as usual, seems to have woke up long after all other cities." Now where did Mr. Traendly get that idea? I challenge him to show that New York or any other city has had more discussions during the past twenty years on the wholesaling of flowers than Philadelphia. "Woke up," forsooth; why Philadelphia was awake and working not only in that line but in nearly every other long before New York got the sand rubbed out of its eyes. If Mr. Traendly will take the trouble to look back through the files of the trade papers he will find that Philadelphia has led, and is leading, in the furnishing of papers worth printing right along. This is a matter of common knowledge and comment these many years. A cheap whack at Philadelphia by a certain class of New Yorkers has long been considered the acme of wit in that burg; but coming from a man who has been honored with the highest office in the gift of the whole country—and that too in the city of Philadelphia—the country at large is apt to consider it undignified, and Philadelphia, in particular, to a man resents it with indignation! When any of the cheap Bowery sports indulges in his natural assiduity in this connection the best thing is to look the other way and pretend not to hear; but it is a different thing entirely in the case of our national president. His attitude should be that of adliberantiphosphornic. He should walk along:—

"His cogitative faculties immersed
In congeniality of cogitation."

While the rest of us:—

"Let silence close our folding doors of
speech
Till apt attention tell our hearts the pur-
port
Of this profound profundity of thought."

A pound of silence is worth a peck of trouble.

GEORGE C. WATSON,
Philadelphia, June 23, 1908.

THE PARIS SALON.

The annual exhibition of the Society of French artists known as "Le Salon" this year is of interest to horticulturists who may be visiting the French capital for a short time. We noted during our stay there a few days ago between 90 and 100 paintings of fruit and flowers of various kinds. We may possibly refer to the most interesting of them in a subsequent issue of HORTICULTURE. C. H. P.

NEWS OF THE CLUBS AND SOCIETIES.

MASSACHUSETTS HORTICULTURAL SOCIETY.

The annual rose and strawberry show, on June 20 and 21, was one of the finest exhibitions of the year. Miss Fay's roses, Farquhar's hardy herbaceous flowers, some new varieties of strawberries, Whitman's sweetwilliams, campanula and delphiniums, and a fine vegetable display, were the features. The rose display made by Miss Sarah B. Fay, of Woods Hole was superb, covering four tables with five hundred or more specimens of the finest blooms ever seen in the hall, attesting the superior cultivation of M. H. Walsh, under whose supervision they were grown. There were some other fine exhibits made by W. A. Riggs, who had a collection covering two tables; W. J. Clemson (J. O. Christenson, gardener), who had a table of blooms of especially fine quality; Mrs. E. M. Gill, W. A. L. Bazeley and others.

Peside the entrance, running around both sides of the hall below the loggia, and over the loggia steps, R. & J. Farquhar displayed a splendid lot of hardy herbaceous plants, and their table of Spanish iris was most attractive both in coloring and arrangement. The Blue Hill Nurseries had a table with *Campanula humosa*, double flowers, of a fine lavender blue color. The Bellevue Greenhouses and Frederick J. Rea had also good exhibits in this class. The centre of the hall was occupied by two tanks, in which the Harvard Botanic Garden showed a fine lot of aquatics including lily, papyrus, nymphacae in variety, pitcher plants and others.

Other of the more notable exhibits in special classes were the sweetwilliams shown by William Whitman (Martin Sullivan, gardener), while the campanulas and delphiniums from the same Brookline estate were of the highest possible quality. On one of the centre tables Edward J. Mitton (J. Lawson, gardener), had a handsome lot of cattloys, George Hollis and T. C. Thurlow fine peonies, and Mrs. John L. Gardner (William Thatcher, gardener), campanulas and delphiniums. Mrs. Frederick Ayer (George Page, gardener) had a fine display of fuchsias and allamandas. There were some novelties in strawberries, the older varieties having been pushed to the rear by the importance of the later seedlings. The sensation in this line was the new Barrymore, which is of surpassing size, fragrance, softness and flavor. It was shown two years ago in a single specimen, last year in a couple of quarts, and is now grown in quantity. It is light red, not seedy, and said to be a large cropper. This is exhibited by H. L. Crane of Westwood. Another new variety is the Franklin, originated by Marshall F. Ewell of Marshfield Hills, which is also a fine berry. A. W. Clark of Ashton, R. L. showed two new seedlings, including the King Edward, not yet introduced, and the Victor, a very large flat berry.

Wilfrid Wheeler was the largest single exhibitor of strawberries, having not less than fifty baskets, includ-

ing fifty different varieties. Isaac E. Coburn had thirty-three baskets and exhibits were also made by John Ward of Newton Centre, Charles B. Travis, Edward B. Wilder and others. There was a special class for strawberries arranged with a foliage as a table centerpiece in which Emily A. Wheeler easily carried off first honors, the others being John Ward and Isaac E. Coburn.

The vegetable display was notably of high quality. Collections were shown by W. S. & J. T. Spaulding of Greenwood Farm, Beverly Farms (F. E. Cole, superintendent), W. J. Clemson of Taunton (J. O. Christenson, superintendent), Colonel Frederick Mason of Taunton (E. L. Lewis, superintendent), and others. Farquhar's new tomato, which has not been named, was shown by W. Downs of Chestnut Hill.

Among the awards outside of the regular prize list were the following:

Silver medal to H. L. Crane, for seedling strawberry Barrymore. Bronze medal to R. & J. Farquhar & Co., for display of Spanish irises. First class certificates of merit to Blue Hill Nurseries for *Campanula humosa* and to Wm. Downs for Farquhar's new tomato. Honorable mention to T. C. Thurlow & Co. for peonies, George Hollis for peonies, R. & J. Farquhar & Co. for display of herbaceous flowers, and F. J. Rea for rose Ruby King.

NEW ORLEANS HORTICULTURAL SOCIETY.

The regular meeting of the above society was held June 18, at 8 P. M., Chas. Eble presiding. As Secretary Pantar was absent, Paul Abele was appointed secretary pro tem. Otto and Paul Abele showed plants of the double lobelia and a bunch of beautiful anemones, the first of the season. This was followed by a general discussion on the care and development of such material. J. A. Newsham was called upon to tell of his researches in Central America. He was very entertaining, and related how he had collected many varieties of orchids. A vote of thanks was tendered him. It was decided to have an outing to Mandeville on July 8. The following committee was appointed to make arrangements: Messrs. P. A. Chopin, Otto Abele and Harry Papworth.

CHAS. R. PANTER, Secretary.

NEW HAVEN COUNTY HORTICULTURAL SOCIETY.

A meeting of the above society was held in their hall in the Courier Building on Tuesday night; about fifty members were present. It was Rose Night. The largest collection—about seventy-five varieties—was exhibited by the superintendent of city parks. Ernest Carrol, gardener to N. W. Kendal, made a splendid display with almost perfect blooms. The Yale Botanical Gardens put up a very fine table. The other chief exhibitors were John Norton, Wm. Symons, Frank Duffy, David Ferguson, James Bruce and David Kydd. Robert Paton and A. J. Thompson were appointed judges. James Kydd read a paper on Rose Culture. The preliminary schedules are already out for the fall show on the 10th, 11th and 12th of November. They can be obtained from Secretary Walter Koella, 58 Bishop street, New Haven, Conn.

MORRIS COUNTY GARDENERS' AND FLORISTS' SOCIETY.

The Morris County Gardeners' and Florists' Society held its regular meeting June 10. It was devoted to "Ferns" particularly. Frank Eskesen, the Madison specialist, read a highly commendable paper on the subject. He went into the details of their culture and invited questions during any part of his lecture, which was largely taken advantage of. His group of ferns in commercial and decorative sizes was very attractive, well arranged and contained many rare kinds. His ferns exhibited to show what he could do, or rather what we ought to do, were fine pieces of artistic work. There was also an exhibit of flowering shrubs and herbaceous flowers from C. J. W. Outlander of the F. & F. Nurseries, of Springfield, N. J., that reflected credit to him. Frau Karl Druschki, the famous white rose, was in perfect condition, from Wm. Duckham, A. Herrington and C. J. W. Outlander; in fact all the roses were fine. John C. Elliott, gardener to J. I. Waterbury, had a carnation rose of the Rambler type; very fine. It is ten days earlier than Crimsen Rambler.

The next meeting will be September 9 and then we shall begin to talk flower show. It is too early to do any predicting; we can only hope. All that is ready now is the schedule.

E. R.

NEW BEDFORD HORTICULTURAL SOCIETY.

This society held its annual rose show in the parlors of the Y. M. C. A. Building on Thursday, June 18. Admission was free and the show was well patronized. An excellent showing of roses was made, the principal exhibitors being Miss S. B. Fay, Falmouth; H. A. Jahn, New Bedford, and James Garthly, Fairhaven. Miss Fay's exhibit consisted of a superb collection of roses in named varieties. Mr. Jahn showed several sweet peas and Lloyd carnations. Mr. Garthly, in addition to a table filled with a splendid exhibit of roses in variety, showed a large vase of Frau Karl Druschki and a small table of single blooms of the same rose. The exhibit of this rose formed the principal attraction. It was noticeable towards the close of the day, that Madame Victor Verdier, Abel Carriere, Duchess of Bedford, Lady H. Stewart and Thomas Willis did not exhibit the staying powers of most of the other varieties; although they received the same treatment they drooped decidedly while the other varieties held up their heads.

THOMAS WHITE

PENNSYLVANIA HORTICULTURAL SOCIETY.

An exhibition of sweet peas and other outdoor flowers was held under the auspices of this society at Horticultural Hall, Philadelphia, on the 23rd inst. The hot weather proved detrimental to sweet peas, but a very creditable display was staged notwithstanding. Samuel Hammond swept all the first prizes in the seven classes scheduled. Mr. Hammond is gardener for Rudolph Ellis, Bryn Mawr, the latter

a great admirer of the sweet pea and giving every encouragement to attain perfection. America, Phyllis Unwin, Othello, Dante, Queen Alexandra, White Spencer, Primrose Spencer, King Edward VII, Flora Norton, Duke of Westminster, Helen Lewis, Stella Morse and John Inglis were among the most distinctive varieties in the prize winning lots. William Robertson, James Coleman and Samuel Batchelor were three exhibitors of sweet peas and carried off a good share of the prize money. Joseph Hurley got first honors for collection of Japanese iris.

A fine feature was the display of perennials and the competition between the Newbold and Paul lots for the Dreer prize was keen, but profiting by the experience at the last rose show the Newbold forces turned the tables completely on the victor with the showy lot and lesser variety, on that occasion. The prize for the best pair of gloxinias went to Mr. Robertson.

All the prizes on this occasion were contributed. Dreer, Michell, Waterer, Bodine and Mahan were the donors.

CLUB AND SOCIETY NOTES.

The cactus dahlia has been made the official flower of the Seattle exposition.

The annual field meeting of the New Hampshire State Horticultural Society was held at the Shirley Hill House, Goffstown, June 25.

At the annual rose show of the New London Horticultural Society at Norwich, Conn., prizes were awarded to Augustus Neuman, gardener for Alfred Mitchell, G. S. Palmer and John Waugh, of New London.

At a recent conference at Council Bluffs, Iowa, relative to holding a national horticultural congress in that city in December at the same time the corn exposition is held at Omaha, President Hess appointed a finance committee, with E. H. Doolittle, chairman, and a membership and hustling committee. An outside hustling committee was also appointed.

The exhibit at the last meeting of the Nassau County Horticultural Society, Glen Cove, N. Y., was so successful that it was decided to hold a rose show, to be open to the public. Two silver medals are offered as prizes. S. J. Trepess, V. Cleres and Mr. Wilson are the committee of arrangements. Mr. and Mrs. J. Rogers Maxwell have donated \$100 for prizes for the fall exhibition.

The annual rose and strawberry show of the Hingham (Mass.) Agricultural and Horticultural Society was held in the town hall June 16. There was a fine display of vegetables and flowers. Geo. Hollis of So. Weymouth showed 56 varieties of peonies. Ernest W. Lincoln and E. E. Lincoln were the leaders in the rose display. H. A. Bates, T. L. Rogers and Fearing Shultz showed strawberries. James L. Jones, M. C. Linscott and Harry P. Cross had fine displays of early vegetables. Mrs. Alfred Cummings, Mrs. Warren Locke and R. W. E. Vining showed fruits and flowers. The exhibition was followed by an address, music, etc.

During Recess

A WARETOWN PASTORAL.

It was a lovely June day, Friday 19th inst., and the waters of Barnegat Bay were dancing in the cool sea breeze as amid cheers and singing, the stars and stripes accompanied by the blue and white pennant of the Florists' Club of Philadelphia, glided to the top of the pole in front of Commodore John Westcott's hospitable club house at Waretown on the Jersey coast, and the opening of the season for the Waretown Rod and Gun Club was thus formally inaugurated.

The story of the three days following this inspiring incident would be but a repetition of the story of many a happy gathering of kindred souls at this delightful retreat provided for the happiness of his friends by a man who finds his own greatest happiness in promoting the pleasure of others. The roll book, on this occasion, showed the names of about twenty guests all from the Philadelphia contingent except John N. May, of Summit, N. J.; Col. W. W. Castle and W. J. Stewart, of Boston. Youthful as ever, the 86-year-old patriarch, Richard Lynex, was the Nestor of the party, which included five ex-presidents of the S. A. F. who frisked and gambolled, day and night, just the same as the everyday folks. An interesting incident was the receipt of a lot of antique weapons, firearms, etc., sent as a present to Mr. Westcott by his friend, James Dean, of Freeport, N. Y. Mr. Dean was unable to be present in person, owing to a recent bereavement in his family. The relics will be used to decorate the walls of the club house and will make quite an attractive addition to the furnishings. Some fishing was indulged in but the fish were out of town on other business and Robert Kift with a score of three weakfish was the "high-liner." This gentleman also served as official photographer and posed his

victims in various characteristic groupings. The official invalid was George C. Watson, who indulged unwisely in raw clams, and the official physician was Robert Craig, who administered approved remedies with the austerity of a stern disciplinarian. Silver-voiced P. J. Lynch furnished the music. The close of the conclave was signalized by an appreciative speech by Col. Castle who voiced the sentiments of the visitors in inimitable eloquence and "the smoke went up the chimney just the same."

NEW YORK FLORISTS' CLUB.

The Eighth Annual Outing of the New York Florists' Club takes place at Witzel's Point View Grove, L. I., on Wednesday, July 1. The good steamer "Isabel" will leave foot of Thirty-first street, East River, promptly at 10 A. M. and will proceed directly to the grove, when the following events will take place in the order named:

- Photograph in Group.
- Baseball Match, Benedicts vs. Bachelors Dinner.
- Races, Starting with Children.
- Ladies' Bowling Match.
- Gentlemen's Bowling Match.
- Dancing.

In addition to the prizes for baseball match, the winning members will each receive a budding knife, value, \$1.25.

The committee of twenty members will be on hand to attend to the comforts of all. Stow's orchestra of seven pieces will play during the entire time.

Program of events will be furnished on application to W. E. Marshall, chairman and treasurer, 146 West Twenty-third street, New York.

PICNICS IN PROSPECT.

- Florists' Club, New York, July 1, at Witzel's Point View Grove, L. I.
- Florists' Club, Columbus, O., July 15, at Buckeye Lake.
- Florists' Club, St. Louis, Mo., July 15, at Normandie Grove.
- Florists' Club, Chicago, July 19, at Morton Grove, Ill.



FLORISTS' AND GARDENERS' CLUB OF RHODE ISLAND.
On the occasion of their visit to the grounds of the R. I. Hospital.

AMERICAN PEONY SOCIETY

SIXTH ANNUAL MEETING AT ITHACA, N. Y.

The meeting was called to order at 7:45 o'clock on Friday, June 19. About twenty members were present. E. A. Reeves acted as chairman of the meeting, President C. W. Ward being unaccountably detained in Michigan. The treasurer also was unable to attend but sent a report by mail which shows the treasury to be in a satisfactory condition. The secretary's report showed the work of the Society to be progressing.

Reports.

Mr. Leon D. Batchelor, who is in immediate charge of the test collections, submitted a report of the expenditures charged against the appropriation made by the Society at its last meeting. This showed that a dressing of stable manure had been applied last fall which served as a mulch during the winter. It is proposed to apply commercial fertilizers and lime the present season, and another dressing of stable manure in the fall.

Mr. Batchelor invited suggestions as to the best methods of procedure in the care of the plots and matter connected therewith. Considerable discussion in regard to this ensued, which finally resulted in the appointment of a committee to confer with the College authorities and see what can be done to better the conditions of the collections, which at present are not as satisfactory as could be wished. The chair appointed as that committee, C. W. Ward, S. G. Harris and B. H. Farr. Mr. Batchelor, in speaking for the Nomenclature Committee, stated that the work was proceeding along the lines originally followed by Mr. Coit, and that over two hundred descriptions had been made the present season.

Professor Whetzel, chairman of the committee on diseases, submitted a letter which stated that he was unable to present the report he had intended to have ready for the meeting. The growers have sent in much good material in the way of diseased specimens, and he has under observation a number of the organisms which he suspects are causing the trouble. The work is well in hand and will be continued during the summer, when a report will be published.

Check List.

Following the reading of the reports various matters of business were discussed. The secretary made the statement that the price of the check list, five dollars, as fixed by the Society last year, seemed to be too high, as there has been but little demand for it, although many inquiries have been made about it, and he suggested that the price be fixed at a figure which would give it a larger distribution. Mr. George moved that the price be made two dollars, and it was voted that it be made that amount.

Frauds.

Matters connected with the exhibitions, advertising and transit in the peony trade were other subjects taken up. The latter subject was brought up by Mr. Farr, who had been badly cheated by a certain prominent peony grower of England. The discussion

developed the fact that this concern has been systematically defrauding American peony growers for years, and measures for reprisal were discussed.

Next Place of Meeting.

The selection of a place for the next meeting was the cause for considerable discussion. The secretary read a letter from Mr. C. S. Harrison, inviting the Society to meet with the Minnesota Horticultural Society at the Fair Grounds between the twin cities, Minneapolis and St. Paul. This invitation was corroborated by a letter from Mr. Latham, secretary of the Minnesota Horticultural Society. Both letters were very cordial and enthusiastic in their statements and called attention to the great business opportunities which the region offers to peony growers. After the reading of these letters, Mr. Brown, representing President Ward, invited the Society to meet at the Cottage Gardens, Queens, N. Y., stating that Mr. Ward had long cherished the idea of having the Society meet with him on the Cottage Gardens premises and had waited until such a time as his plants would be in fine condition for studying the varieties, of which he has a very large number. Next year should find them in such a condition, and it is the belief of Mr. Ward that considering that the most important thing for the Society to settle is still in the line of nomenclature matters, no greater help could be given this work than by meeting as suggested. He could offer the best of accommodations for holding an exhibition and would place all the conveniences of the establishment at the disposal of the exhibitors and visiting members. Ithaca was also suggested as the best place for the meeting. After a thorough consideration of the merits of the various places proposed, it was unanimously voted to hold the meeting at Queens, N. Y., the members feeling in doing so that they were not disparaging the merits of the other places but believed that the chance is a most opportune one for studying a large commercial collection in the interest of nomenclature.

Election of Officers.

The election of officers resulted as follows: President, C. W. Ward; vice-president, C. J. Maloy; secretary, A. H. Fewkes; treasurer, J. Howe Humphreys. E. A. Reeves was elected to succeed himself as director for three years.

A resolution was passed expressing appreciation of the work done by the college in furthering the nomenclature work undertaken by the society and asserting the belief that the society should co-operate with those in charge of bringing the work to a successful termination.

A vote of thanks was given Mr. Batchelor for his work on behalf of the society and the courtesy and attention extended by him to all present. The exhibition was a small one, there being only two exhibitors, Professor Saunders of Clinton, N. Y., who had entries in all the amateur classes, and F. C. Thurlow Co. of West Newbury, Mass., who had exhibits in the classes

for fifty blooms, and the general collection. The flowers staged from the test collections helped out the exhibition greatly.

A. H. Fewkes, B. H. Farr and R. T. Brown were elected judges to examine the exhibits and award prizes.

Report of the Secretary.

The present membership of the society is forty-nine, not including four honorary members.

It is gratifying to note that the membership is steadily increasing, slowly to be sure, but in a substantial manner. Those who have dropped out are few and are greatly overbalanced by the new members which are annually admitted.

Since the last meeting the work of the society has been progressing. The Committee on Diseases has sent out a large number of circulars of inquiry which have brought out much information, but which has not as yet been reduced to an orderly condition.

The Nomenclature Committee have the result of the work done by Mr. Coit last summer, in press, in the form of a bulletin, which will be issued shortly.

The secretary has the Proceedings of the Society for the five years from 1903 to 1907, inclusive, in the hands of the printers, and will distribute copies to the members at the earliest opportunity.

In response to the circulars sent out by Prof. Craig last July, in regard to forming a supplementary test collection, a large number of roots were sent in and were planted in accordance with the expressed wishes of the society. These as well as the older collection were top dressed with stable manure last fall, which served as a mulch during the winter.

The exhibition held during the meeting last June was somewhat disappointing, owing principally to the lack of growers in the immediate vicinity of Ithaca, and the dates being unfavorable to those at a distance.

In regard to the diseases of the peony, we can not be too watchful or too persistent in our endeavor to learn all that can be found about their nature, and about different means to prevent them. To the commercial man the matter is not of a directly serious nature, but to the amateur and indirectly the commercial man, it is most serious.

I have in mind a peony garden near Boston which was stocked with many rare and choice varieties. Many of the plants had reached their third and fourth years, and were fine large plants. During last summer the wilt and black rot attacked many of them, causing much loss and distress to the owner. In the fall large roots were dug up which were completely destroyed.

This is but one instance; there are many others who are sufferers and so situated that they can not change their plants to new ground but must either give up growing the peony or find some means of checking or preventing the spread of these diseases.

A. H. FEWKES, Sec.

Obituary

THE LATE ALEXANDER WALLACE.

Since writing the obituary notes which appeared in our issue of last week, some additional facts in the life of Mr. Wallace have come to our knowledge. His early boyhood was one of hardship. At three years of age he was bereaved of a mother's love; a father's care he never knew. At the age of 13 he was feeld out to a farmer, and for two years his lot was one of hard work, abuse and scanty fare. At 15 he found employment with the Caledonia R. R. in his native village in Scotland, where he acquitted himself creditably, and step by step he progressed until he became private secretary to a prominent attorney in Dundee, he having in the meantime taken up the study of shorthand, in which he became remarkably proficient. His knowledge of this art was the foundation of much of the success which he met with in later years. He came to America in 1882, but after a short time returned to Scotland, coming back again in 1888, and soon obtaining employment with A. T. De la Mare on the Florists' Exchange which was then in its infancy. Mr. Wallace's services to the Florists' Exchange are well known to our readers. The story of his life from that time is the story of the paper. His capacity for labor was prodigious. Patiently plodding, working uninterruptedly from early morning until late at night, leaving nothing unfinished, he was always to be found at the post of duty.

Mr. Wallace was a writer of poetry and a constant contributor of short stories to the Scottish American. In the year 1900 he compiled for the sixteenth annual meeting of American Florists, in New York, the souvenir book of the New York Florists' Club, a painstaking and thorough record of the annals of early horticulture in and around New York city, a work which occupied him through many months of patient research in the libraries. In 1906 he prepared an article entitled "What Scotsman have done for Horticulture in America," to be read before the members of the Scottish Horticultural Association. This paper was widely copied in English horticultural journals and received much favorable comment. Probably his most ambitious work and that which will carry his name and fame down to posterity as an author, was the book published in 1903 entitled, "The Heather in Lore, Lyric and Lay." This work, the result of several years of research throughout the libraries of America and Great Britain, is a complete synopsis of the history of Scotland's flower and emblem, including all the literature, both poetry and prose, which it was possible for the writer to glean.

Mr. Wallace assisted largely in the compilation and editing of the various text books which have been issued from time to time by the publishers of The Florists' Exchange. His uncompleted work was "Favorite Flowers of Robert Burns," and in the last

hours of his life he was regretting his inability to proceed with the work he had so lovingly set forth to do.

With the following verses written by him a few years ago, we close our brief biography of Alex. Wallace.

MITHER'S KISS.

When infant pains perplexed me sair,
An' ailments, 'boon what I cud bear,
Robbed childhood o' its bliss,
A balm that failed tae cure but rare
Was mither's soothin' kiss.

When fancied wrongs, 'boot bood or ba',
War ranklin' in my bosom sma',
An' things wad gang amiss,
A truce was made amang us a'
By mither's lovin' kiss.

An' when I left my dear auld hame
Tae Fortune seek - that fickle dame
The goal tae hit or miss,
The guide that pointed strait my aim
Was mither's partin' kiss.

Tae me nae kindly ear she's lent,
But o' a' the trials by Fortune sent
The hardest yin was this -
When owg a pale, worn face I bent
For mither's dooin' kiss.

When Boatman Death, sae grim an' hoar,
My saul has safely ferried o'er
The great unknown abyss,
May it greet me on the ither shore -
My mither's welcome kiss.



ALEXANDER WALLACE

At a special meeting of the directors of the A. T. De La Mare Ptg. & Pub. Co., Ltd., publishers of The Florists' Exchange, held at noon, Saturday, June 20, 1908, the following resolutions were adopted:

Whereas, Most vividly the uncertainty of the tenure of life has been demonstrated through the sudden removal from our midst of our friend and fellow worker, Alexander Wallace, who went for rest from pain and earthly cares, with a smile of perfect peace on his face, to the arms of our Heavenly Father, on Wednesday, June 17, 1908, and

Whereas, We desire to place on record our testimony to his long and faithful career in the office of this Company, and to bear testimony to his zeal, diligence and unwavering loyalty in all things which made for our common good; therefore, be it

Resolved, That in the death of Alexander Wallace we have lost a brother whom we mourn with all our heart, a tried and true coadjutor, a manly man, a faithful friend, a valuable citizen, and we do hereby express our profound and sincere grief at his untimely death in the hour of his matured mental vigor and manhood; and be it further

Resolved, That these resolutions be expressed in full upon the minutes of this Company, and a copy thereof sent to the bereaved widow of the deceased.

Emanuel Hippard.

Emanuel Hippard, a well-known florist and business man of Youngstown, O., died on June 16, aged 63 years. Mr. Hippard was stricken with paralysis in Jacksonville, Fla., six weeks ago while returning to Youngstown from a trip to Cuba. He was brought home a short time later in a serious condition from which he never rallied.

Deceased was born in Elizabethtown, Pa., Aug. 6, 1845. He was married to Miss Catherine Auchenbach, Nov. 4 1866.

Mr. Hippard moved to Youngstown in 1882, and immediately began a business career which marked him as a man of ability in many lines. Shortly after his arrival there he purchased the property in West Rayen avenue, where the family now resides, and erected thereon a number of greenhouses. Later he constructed the large building now owned by Dr. Booth and opened a flower store. For ten years he conducted these enterprises jointly, with credit to himself and to the city.

About this time he purchased the farm where the greenhouses of John Walker are now located. These greenhouses were built by Mr. Hippard and conducted by him until a few years ago when he disposed of them to Mr. Walker. For a number of years he has manufactured and sold as a specialty the Standard Steam Trap for greenhouse use.

For years Mr. Hippard served in the navy of the United States on board the man-of-war "Wachusett." During the last years of the Civil War he saw service in the 20th Pennsylvania cavalry. He was a member of Tod Post, No. 29, G. A. R.

Mr. Hippard is survived by his wife and one daughter. The latter is Mrs. C. J. Little of Youngstown.

Our personal acquaintance with Mr. Hippard has been long and pleasant. We found him at all times a genial, considerate, courteous gentleman. He was a member of the S. A. F. from the early years of that organization, a constant attendant and frequent exhibitor at the conventions. In his business relations Mr. Hippard was always a man of honor, in his home life he was ideal, and his demise is a great loss to the trade and to his town.

John Cammack.

John Cammack, a well-known business man of Washington, D. C., formerly a florist, died at his home, 2553 Brightwood avenue, on the 15th inst.

MONSIEUR ABEL CHATENAY.

This distinguished French horticulturist, and secretary of the National Horticultural Society of France, if not known personally to many Americans interested in the gardening art, must be well known by name. It may be used to draw a tention to the fact that a very fine portrait of M. Chatenay is exhibited in this year's Paris Salon. Those American who happen to be staying in Paris during the summer and who would like to see the portrait should note the picture No. 861 by Leon Armand Hult, entitled "Portrait de M. A. C. . . ." It is a life-like three-quarter length picture of the gentleman whose name heads this note. C. H. P.

THE ALASKA YUKON PACIFIC
EXPOSITION.

In an interesting letter from Seattle under date of May 29, Mr. J. Fred. Dawson, of Olmsted Bros., describes the progress being made in the building and landscape work for the Alaska-Yukon Pacific Exposition. Several of the large buildings are already finished. Most of the rough grading has been completed. "We are just starting the finish grading in the vicinity of the Geyser Basin and south along Rainier Vista, Washington Vista and Union Vista. These vistas vary from two to four hundred feet wide and were cut through thick growths of Douglas firs, many of the trees being over three hundred feet high and 4 to 10 feet in diameter. The entire layout is centered on Mt. Rainier which is over 14,000 feet high and is covered with snow the year round. Along the Washington Vista you can look out across many miles of Lake Washington with the great range of Cascade Mountains whose caps are covered with snow, back of it.

"Along the Union Vista you look across the waters of Lake Union to heights of the city beyond. We expect to fringe the base of all the buildings in the central Court of Honor with thousands of large native rhododendrons, together with fox-gloves, lilies, peonies, etc., mixed through them. The formal gardens, which are almost ready to be planted, are just south of the great Geyser Basin on the line of Rainier Vista.

"I expect to remain here for a few weeks yet with Mr. Olmsted and then go to Spokane and Portland. We have just submitted our report to the Park Commissioners of Spokane, Wash., for a system of parks for the entire city. We are now preparing plans for the development of some of the parks already owned by the city. We have several private places there, the largest of which is owned by L. M. Davenport who keeps the finest restaurant in the Northwest. William Donald is carrying out our plans for us there and is getting along finely."

GHEENT QUINQUENNIAL SHOW.

All the reports of this great gathering in Europe unite in pronouncing it to be one of the finest horticultural shows ever held. Most of the leading horticultural journals have contained reports, some of them well illustrated, with very full details of the exhibits and festivities. Lord Reddick presided, M. Viger being the next in the post of honor. Our bright little Belgian contemporary, "La Tribune Horticole," of Brussels in several of its recent numbers gives full particulars, many portraits of those concerned in organizing the show, some views of the show, and a four-page group of the members of the jury. Among them we recognize many of our old friends on the other side of the Channel. Bravo! little Tribune Horticole. C. H. P.

The plans submitted by W. H. Ritchie, Boston, were accepted by the Massachusetts Agricultural College, Amherst, Mass., for the new greenhouse and accompanying buildings.

CATTLEYA GIGAS SANDERIANA.



Our illustration shows a plant of this beautiful cattleya exhibited by Joseph A. Manda at a recent meeting of the New Jersey Floricultural Society where it caused quite a sensation

among the orchid fraternity. It was in a six-inch pan, with eight bulbs and carried ten well developed flowers. The plant came in last year's importation.

NEWS NOTES.

A fire in the building occupied by H. Corvi, florist, San Francisco, Cal., June 8, was discovered before it had done great damage in his store.

A big fire in the up-town section of New Orleans, La., destroyed the florist establishment of Justin St. Mard, who is reported to have lost \$10,000.

Plans for extensive alterations and improvements are under way in the florist store of A. M. York at Calumet, Mich. Mrs. Norquist will be in charge as heretofore.

Howard Stone has closed his branch store above Hotel Fulmer, Stroudsburg, Pa., for the summer, and transferred that business to the greenhouse, 183 Scott street.

The will of Mrs. Jerome Jones, whose death we recorded in a recent issue bequeaths \$75,000 to various hospitals and charitable institutions in Boston and Brookline, Mass.

The Civic Improvement League of Denison, Texas, finds the interest in the school garden work unabated, there having been many claimants for the awards at the end of the school year. All are eagerly anticipating the annual

flower show scheduled for November 4, 5 and 6.

Frank Ben, Chicago, Ill., is just completing three large new greenhouses, the widest of which accommodates seven benches. This one is now planted with chrysanthemums to be followed by Kaiserin.

Mrs. James McMillan has presented the North Shore (Mass.) Society with a silver cup to be known as the Eagle Head cup. This is to be offered in a rose competition to be competed for in an exhibition of 10 varieties of garden grown roses, four blooms each, and is to be won three times in succession before becoming the absolute property of the exhibitor. The above conditions have been changed from those as originally intended and as they appear in the printed schedule which specifies that there be three blooms, each variety to be correctly named, and to be won twice before becoming the absolute property of the exhibitor. At the last meeting of the society the subject of incorporation was brought up by the president and after a little discussion the matter was referred to a committee who will make their report at the next meeting. Philemon R. Sargent exhibited a fine table of rhododendrons.

LILIUM HARRISII

We offer a selected stock of the original true Harrisii for early forcing. These bulbs have been grown from the original pure Harrisii, and will be found to be splendid stock for early forcing, for which purpose Harrisii is so valuable. We have had the stock inspected, and are assured that it is almost absolutely pure and almost entirely free from disease. This is not stock picked up indiscriminately from different sources, but is grown from one stock, and will be found very superior to the ordinary Harrisii usually offered, both in regard to freedom from disease and purity, and not the late type now so often furnished.

Lilium Harrisii has been deteriorating slowly for years, and in order to get back to the true type of the original Harrisii, we have had our stock grown from the original pure stock, and it will be found very superior to the Lilium Harrisii usually offered. While the stock is A No. 1, our prices are as low as, or lower than, the prices asked for indifferent stock.

We have only a limited quantity of this stock to offer, so it will be advisable to place order without delay in order to ensure securing the stock. Bulbs ready for delivery middle to last of July.

6-7 in. bulbs, 350 to the case, \$6.00 per 100, \$50.00 per 1000 } Full Case Lots at Thousand Rates
 7-9 in. bulbs, 200 to the case, 9.00 per 100, 80.00 per 1000 }
 9-11 in. bulbs, 100 to the case, 18.00 per 100, 170.00 per 1000 }

FREESIA REFRACTA ALBA Bermuda-grown, finest selected bulbs, 1/2-in. up, \$1 per 100, \$7.50 per 1000.
 French-grown, Mammoth size, 3/4-in. up, \$1.50 per 100, \$12 per 1000.

F. R. PIERSON CO., Tarrytown-on-Hudson, New York

BUSINESS CHANGES.

H. F. Ehresmann has bought out the florist establishment of John Lees, Frankford, Pa.

The Rocky River establishment of the Gasser Co., Cleveland, O., will be under the management of F. H. Friedley hereafter.

Joseph Richards has purchased the interest of his partner at Atlantic City, N. J., and will continue the business at 1423 Pacific avenue.

H. H. Hensley has leased the plant of the Long View Floral Co., Rock Island, Ill., and will carry on the business in connection with his other establishments in that place.

William Thomas has purchased the greenhouse of F. W. Meyer, Kalamazoo, Mich. Mr. Meyer will take the position of head gardener at the State Agricultural College, Ames, Ia.

POT CHRYSANTHEMUMS

BEST VARIETIES FOR BUSH PLANTS IN POTS

Large Flowered, Pompon, Anemone Flowered and Single.

Good Assortment in Early, Mid-season and Late, 2 1/2 in. 50c per doz., \$3 per 100.
 4 1/2 in. in pots, \$1 per doz., \$8 per 100.

PRIMULA OBCONICA and **P. CHINENSIS**
 Best Varieties

Ready July 15th, 2 1/2 in. pots, \$2.00 per 100, \$25.00 per 1000.

FERNS for DISHES

Assorted Varieties, from 2 in. pots, \$3.00 per 100, \$25.00 per 1000.

CASH WITH ORDER

FRANK OECHSLIN

2570-2606 W. Adams St., Chicago.
 Formerly Garfield Park Flower Co.

GERANIUMS

Strong, stocky plants in bud and bloom: scarlet; crimson; white and pink. 4 in. pots, \$6 per 100

S. J. RUETER & SON, Inc., WESTERLY, R. I.

FERN S

Assorted for JARDINIERES

Strong, healthy plants 2 1/4 inch pots, \$3.00 per 100 \$25.00 per 1000; 500 at 1000 rate. 3 inch, \$6.00 per 100.

FRANK N. ESKESEN, MADISON, N. J.

FERNS IN FLATS

All the Leading Sorts

READY JULY 1st

Terms and Prices on Application

E. LEULY, 528 SUMMIT AVENUE W. Hoboken, N. J.

In ordering goods please add "I saw it in HORTICULTURE."

NEP. WHITMANI

2 1/4 in., \$5.00 per 100

NEP. WHITMANI

3 1/2 in., \$25.00 per 100

BOSTON FERNS

2 1/4 in., \$3.00 per 100

H. H. BARROWS & SON Whitman, Mass.

NEPHROLEPIS SCOTTII

in the following sizes, extra good value

25c., 50c., 75c., and \$1

Grand Specimen Plants at \$3, \$4, \$5, \$6.

JOHN SCOTT

Rutland Road and E. 45th St.

Tel. 2890 Bedford **BROOKLYN, N. Y.**

CHRYSANTHEMUMS

in all standard varieties and colors now ready for planting from 2 1/4 pots, \$3.00 per 100, \$20.00 per 1000.

CHARLES H. TOTTY, Madison, N. J.

ORCHIDS

Arrive in good condition Cattleya Mossiae, C. Gaskelliana, C. Spectabilissima. In a few days, C. gigas Sanderiana and others.

ORDONEZ BROS., Madison, N. J.

ORCHIDS

Arrived in Grand Condition

CATLEYA APETHYSTODLOSSA true
CATT. BOWRINGIANA
LAELIA GRANDIS TENEBROSA
ONCIDIUM SARCODES

Write for Prices

To arrive shortly

Laelia purpurata, Laelia Boothiana (lobata), Oncidium varicosum Rogersii.

JOSEPH A. MANDA

191 Valley Road WEST CRANGE, N. J.

ORCHIDS

Largest Importers, Exporters, Growers and Hybridists in the World

Sander, St. Albans, England and 235 Broadway, Room 1 NEW YORK CITY

IMPORTED ORCHIDS

Arrived in Superb Condition

Vanda coerulea, Cattleya Trianae, Cattleya gigas Sanderiana, Cattleya Schroederiae, Oncidium varicosum.

JULIUS ROEHRS CO., Rutherford, N. J.

ORCHIDS

Arrived in fine condition, C. Mossiae, C. Percivaliana, C. Trianae, C. labiata, C. gigas Sanderiana, C. Harrisianae, C. Schroederiae, C. citrina Den. Formosum giganteum, D. Wardianum, D. Findleyianum, Oncidium Varicosum Rogersii, O. Tigrinum, O. Ornithorhynchum, Laelia anceps. To arrive shortly, Vanda Coerulea, Cattleya Gaspelliana, C. Mendellii, Phalaenopsis Amabilis, P. Schilleriana.

GARRILLO & BALDWIN, Secaucus, N. J.

Look through the Buyers' Directory and Ready Reference Guide. You will find some good offers there also.

ORCHIDS

arrived in superb condition
Cattleya Trianae, C. labiata C. Mossiae, Oncidium Varicosum, Vanda Coerulea, Dendrobium Formosum and D. Dalhousieanum.

LAGER & HURRELL, Summit, N. J.

PROPOSED LAW AFFECTING INSECTICIDES.

On Thursday, June 18th, beginning at 10 A. M., there was an all day session held in the American Institute Building, West 11th street, New York City, between manufacturers, representatives of the entomologists, and some of the leading chemists who have charge of the state control of the insecticide laws for the discussion of Senate Bill 6515 and House of Representatives Bill 21316 entitled "A bill for preventing the manufacture, sale or importation of adulterated or misbranded fungicides, paris greens, lead arsenates and other insecticides, and for regulating traffic therein and for other purposes." There were about forty persons present, and all business commenced promptly.

The Senate Bill and the House of Representatives Bill are the same, excepting that in section 7 there is a fourth clause added to the House of Representatives Bill, which was amended. Section by section was taken up. The bill appears to be promulgated by those connected with the Agricultural Department.

The first section provides that any violation is a misdemeanor, punishable by a fine not to exceed \$500 or one year's imprisonment, or both, and if brought up on a second count the fine is doubled with the imprisonment clause in the discretion of the court. This section was adopted. Sections 2 and 4 the same.

Section 1, which provides for the examination of specimens of fungicides, paris greens, lead arsenates and other insecticides, called for discussion looking for enlightenment. Under section 4 a motion was made to insert the word willfully (willfully violated), but the entomologists and representatives of the Department voted against that, and in section 5 a discussion arose as to who should have the authority to start prosecution, and a clause "Under authority of the Secretary of Agriculture" was inserted, so as to make it plain that in the National Bill there was some head to its enforcement and not leave the initiative to any director of Experiment Stations or agent of any State, or the District of Columbia.

Sections 6 and 7 caused the most discussion. The intent of the promoters of the bill seems to be to concentrate unquestioned authority of oversight in the hands of the Department of Agriculture, and the manufacturers brought up various questions, all of which were fairly and frankly considered.

In section 6, the words "Man or other animals" were stricken out so as to confine the section to its legitimate purpose, that of affecting insecticides used upon vegetation. There was also a definition added, that the term "Miscible Oils" shall include all preparations of petroleum to be used in water. In section 7, after some discussion in which the actual work of the manufacturing chemist is compared with the laboratory chemists' small tests, the amount of arsenious Sulfide As₂O₃ was made 50 per cent.

"STOKES STANDARD" PANSY SEED

Stokes' Standard Mixed Pansy is the finest strain of Giant Pansies it is possible to produce. It is a blend of all that is finest in Pansies from France, England and Germany. It is absolutely unrivaled in range of magnificent colors, size and substance. Trade pkt. (2000 seeds) 50c; 1/8 oz. 85c; 1/2 oz. \$3.25; 1 oz. \$6.00; 1/4 lb. \$20.00.

Kingly Collection of Giant Pansies Mixed. A most excellent strain, the same as has been sold for years by the late firm of Johnson and Stokes and has given great satisfaction. Price, 1/2 trade pkt. 30c; trade pkt. (2000 seeds) 50c; 5000 seeds \$1.00; per oz. \$5.00; per 1/4 lb. \$14.00.

Send for Special Pansy Circular

FRENCH and DUTCH BULBS in season—CET PRICES

STOKES' SEED STORE, 219 Market St., Philadelphia, Pa.

instead of 55 per cent. The standard of lead arsenates is one of the things which are indefinite. There is a variation in the actual working of these things from the commercial basis, where they are sent out literally by the tons. To make a commercial article match a chemically pure preparation for a special test, the quantity of water permissible, the actual working conditions of transportation, the evaporation of water by a leaky package, that is to say the real "work-a-day" conditions, which all commercial articles are subject to were talked over, in effecting any penalty, and the result of the talk was apparently some enlightenment, and the expression of opinion by the professional entomologists that no construction was wished by putting into the bill or to be made a part of it, anything which could in any way hamper fair trade.

The fourth division of the House Bill reads, "Any article which is intended for use on vegetation and shall contain any substance or substances which, although destroying, repelling or mitigating insects, shall be injurious to such vegetation." This clause, which is not in the Senate Bill, was taken up as it is a trap which might be used to the great annoyance and harm of anyone, for there are no substances commonly used but what if a small overdose is used will destroy vegetation, and as the paragraph read there was no explanation to its construction.

To qualify this paragraph the sentence, "By following the directions expressed upon the package," was added. With this amendment the section was adopted.

A question arose in regard to selling in foreign countries; that while the Consular Service of the United States was endeavoring to increase foreign trade, the demands of foreigners, which may call for something entirely different from what is used in this country, should not in any way be restricted.

A motion was made that the Bill as amended according to the secretary's notes be adopted and the same was carried.

A resolution was offered on part of the manufacturers to the effect that they thank the gentlemen in charge of this meeting, Mr. E. Dwight Sanderson of Durham, N. H., and Prof. Smith of New Brunswick, N. J., for inviting them to be present.

BENJAMIN HAMMOND

DETROIT PARK BOARD vs. SAN JOSE SCALE.

This is a most important issue, fully recognized by Park Commissioner Philip Preitmeyer, who has had an ordinance passed which enables him to not only inspect plants under his direct supervision but also those on private property. Property owners are disposed to co-operate heartily. Several inspectors are going through the streets, etc., etc., and every plant which is infested is tagged with a yellow cardboard on which is printed: "This Tree, Shrub, Must be Sprayed"; such as are beyond redemption or already dead are tagged with a red cardboard on which it is stated that the plant must be removed. Laborers follow the inspector and act according to those cards.

FRANK DANZER.

SEED TRADE NOTES.

Albert McCullough and family started from the Detroit convention en route for London, Eng.

The Fredonia Seed Co., Fredonia, N. Y., are erecting a three-story building to be used as office, factory and retail store.

The model seed farm at Milford, Va., which T. W. Wood & Sons, of Richmond, Va., have recently added to their already large holdings, will be in charge of an expert seed grower.

VEGETABLE PLANTS

CABBAGE Wakefield, Early Flat Dutch, Early Allhead, Early Drumhead and other early varieties. Surehead, Late Flat Dutch, and other late varieties at 20c per 100, \$1.00 per 1,000, \$8.50 per 10,000.

TOMATO Stone, Favorite, Paragon, etc., at 20c per 100, \$1.00 per 1,000, \$8.50 per 10,000. Dwarf Stone and Champion, June Pink and Early Jewell at 40c per 100, \$2.00 per 1,000.

CELERY White Plume, Giant Pascal, Gol. Heart and other varieties, 20c per 100, \$1.00 per 1,000, \$8.50 per 10,000.

BEET Eclipse, Crosby and Egyptian, 25c per 100, \$1.25 per 1,000. Cash with order.

R. VINCENT JR. & SONS CO. WHITE MARSH, MD

Seed Trade

AMERICAN SEED TRADE ASSOCIATION.

The 20th Annual Convention of the American Seed Trade Association met on June 23 at the Hotel Pontchartrain, Detroit, with President George S. Green in the chair.

A very muggy, warm atmosphere made everything most uncomfortable but the convention was well attended and received a hearty welcome to the City of the Straits by City Comptroller Doremus. He was courteously answered by S. F. Willard.

President Green's address followed and then came the reports of Secretary and Treasurer C. E. Kendel.

Mr. Chas. N. Page offered a resolution to work in favor of any reasonable regulation of Parcels Post.

D. M. Ferry & Co. invited the members to visit their trial grounds on Wednesday morning and to a boat ride on Thursday at 1.30 p. m.

The convention went into executive session at 8 p. m., Tuesday.

On Wednesday evening, June 24, the members were entertained at a banquet. Music, decorations, singing and speeches by local and visiting members were of a high order. Mr. Northrup served as toastmaster.

At the session on Thursday forenoon officers were elected as follows: President, W. S. Woodruff, Orange, Conn.; first vice-president, J. C. Robinson, Waterloo, Neb.; second vice-president, Marshall H. Duryea, New York; secretary and treasurer, C. E. Kendal, re-elected, Niagara Falls was favored for the next meeting. The executive committee will decide at its meeting next January. A fruit dish was presented to outgoing President Green by J. C. Robinson. All the meetings were well attended and the program carried out as scheduled.

Albert Houle, of Toronto, Can., has purchased the Abbs greenhouses in that city and started in business.

Rubber Hose

Michell's Special for Florists' Use

Our 3- and 4-ply Hose is durable and flexible and will stand any amount of hard usage.

3-ply 12c per foot; 4-ply 14c per foot

In 25- and 50-foot sections.

MICHELL 1018 MARKET ST. PHILA., PA.

PRIMROSE SEED IMPROVED CHINESE

Finest grown large flowering, fringed, single and double, 15 varieties, mixed, 500 seeds, \$1.00; half pkt., 50c. Have the varieties separate, also.

JOHN F. RUPP, Shiremanstown, Pa THE HOME OF PRIMROSES.

SWEET PEAS

For THANKSGIVING and CHRISTMAS

BODDINGTON'S CHRISTMAS WHITE.....	Oz.	1/2 lb.	1/2 lb.	1 lb.
" " " PINK.....	10c	40c	60c	\$1.00
" " " SNOWBIRD, the earliest forcing white ...	10c	40c	60c	1.00
FLORENCE DENZER, (pure white)	20c	75c	1.25	2.00
WATCHUNG, (pure white)	10c	40c	60c	1.00
	20c	75c	1.25	2.00

Also other varieties as advertised prices. All the above mailed free.

PANSY-BODDINGTON'S "CHALLENGE." This mixture contains all the finest giant strains of the leading Pansy Specialists in the world—the Giant self-colors, the Giant striped and margined, and the Giant blotched—all carefully mixed in proportion. Tr. pkt. 75c.; 1/2 oz. \$1.50; 1/2 oz. \$2.75; oz. \$5.00.

ARTHUR T. BODDINGTON, Seedsman
342 West 14th Street, - NEW YORK CITY

ASTER GROWERS ATTENTION:—

Our Seed is All Sold. If you failed to get some it is your loss. However:— Get a Competition Card Now, Enter your name as an Aster Grower of America and win part of our \$250.00 offered in prizes. Entry free. All information gladly given. No cost to you except to prepay the express charges on flowers sent in competition.

Altimo Culture Co., Canfield, Ohio.



THORBURN'S BULBS

LILIUM HARRISII, 5-7 in.	100	1000
7-9 "	\$4.50	\$40.00
	8.50	80.00

Seed for advance prices on Holland Bulbs, Japan Lilies and Roman Hyacinths.

ASPARAGUS PLUMOSUS ROBUSTUS, \$2.00 per 1000 seeds.

Pansy, Carnation, Daisy and all other seeds for florists. Cold Storage Lily of the Valley Pips

J. M. THORBURN & CO.
33 Barclay St., through to 38 Park Place
NEW YORK

Best Quality Fall Bulbs

It is to your advantage to place your order early. Send us a list of your wants and we will quote you rock-bottom prices. Copy of our Florists' Bulb Catalogue will be sent upon request. Catalogues now ready.

VICK'S SUPERB PANSY SEED

All the best varieties in separate colors

VICK'S SUPERB MIXTURE

the best strain from the leading named sorts
1-8 oz. 75c. 1-4 oz. \$1.50 Ounce \$5.00

JAMES VICK'S SONS, Rochester, N. Y.

PANSIES

Fresh Seed Just Arrive

We can supply all the leading strains. Our Florist List Mailed Free.

H. E. FISKE SEED CO.
12 Faneuil Hall Sq., BOSTON, MASS.

CABBAGE SEED

HJALMAR HARTMANN & CO.,
12 Stormgade,
COPENHAGEN, DENMARK.

SOW NOW MY STRAIN OF

Hardy Garden Carnations as:

Special Mixture of extra double flowers.....	Per Oz.	Tr. Pkt.
Dwarf Scarlet Grenadin.....	\$2.50	.30
Early Dwarf Vienna, finest mixed.....	2.00	.30
New Early White Vienna, fine for cut.....	1.00	.20
New Early Dwarf Hardy Garden Pinks, in splendid colors, mixed.....	1.50	.20
	4.00	.50

O. V. ZANGEN Seedsman Hoboken N. J.

JUST ARRIVED

LARGE SHIPMENT OF

High-Grade SCOTCH SOOT.

We have the Stott Double Nozzle
THOMAS J. GREY CO.

32 & 33 So. Market St., BOSTON

BRIDGEMAN'S SEED WAREHOUSE

RICKARDS BROS.

Props.

37 East 19th St., - NEW YORK CITY

BRASLAN SEED GROWERS CO.,

GROWERS FOR THE

WHOLESALE TRADE ONLY

SAN JOSE, - - CALIFORNIA

BRECK'S SEEDS

For Farmer, Market Gardener and Florist

New Crop High Grade

Catalogues mailed free on application

Joseph Breck & Sons Corp.
47-54 NO. MARKET ST., BOSTON, MASS.

Winter-flowering SWEET PEA SEED

All Colors

New crop ready in August next. Ask for list.

A. C. ZVOLANEK
ORIGINATOR. BOUND BROOK, N. J.

Burpee's Seeds

PHILADELPHIA

Blue List of Wholesale Prices mailed only to those who plant for profit.

Chicago.

Established in 1857



1657-1659 Buckingham Place

L. D. Phone 558 Lake View. Send us your retail orders.

We have the best facilities in the city.

ALEX. McCONNELL

571 FIFTH AVENUE
NEW YORK CITY

Telegraphic orders forwarded to any part of the United States, Canada, and all principal cities of Europe. Orders transferred or intrusted by the trade to our selection for delivery on steamships or elsewhere receive special attention.

Telephone Calls, 487 and 488 38th St.
Cable Address, ALEXCONNELL

DAVID CLARKE'S SONS

Deliver orders from any part of the country to
New York City

Or OUT-GOING STEAMERS

Write or telegraph

2139-2141 Broadway, New York
Telephone 1552-1553 Columbus

YOUNG & NUGENT

42 West 28 St., NEW YORK

"FLOWERS BY TELEGRAPH"

Flower Deliveries

in Brooklyn and other Long Island Points
New York City, New Jersey, etc. At Theatres,
Hotels, Steamers or Residences.

WILSON

Fulton St. and Greene Ave., Brooklyn, N.Y.

ALBANY, N. Y.

EYRES

Flowers or Design Work

DELIVERED IN ALBANY AND VICINITY
ON TELEGRAPHIC ORDER.

11 NORTH PEARL ST., ALBANY, N. Y.

YALE

Orders for flower
deliveries to Yale
College and all
other Connecticut

points carefully filled and delivered by

J. N. CHAMPION & COMPANY

1026 CHAPEL STREET NEW HAVEN, CONN.

JACOB SCHULZ, 644 Fourth Ave.,
LOUISVILLE, KY.
Cut Flowers of BEST QUALITY in season
delivered promptly to any address.

Write, Telegraph or Telephone.
Cumberland and Home Phones 223 and 984

ATLANTA FLORAL CO.

41 Peachtree Street, ATLANTA, GEORGIA.

In ordering goods please add "I saw
it in HORTICULTURE."

Of Interest to Retail Florists.

WOMEN IN CHICAGO FLORIST TRADE.

There are at present no less than eight women representing eight greenhouse establishments occupying their respective stands in the Chicago cut flower market. Mrs. Frank Beu has been there longest and is well known as a good business woman. Miss Josepha Then, Miss Hertha Tonner, Miss Martha Gunterberg and Miss Ida Ebert are all bright young ladies having entire supervision of the flowers grown by their fathers and brothers, and having a personal interest in the business. Mrs. A. W. Meyer handles all

STEAMER DEPARTURES

Allan.

Virginian, Montreal Liv'p'l...July 3

Tunisian, Montreal Liv'p'l...July 10

Anchor.

Columbia, N. Y.-Southampton...July 4

American.

St. Paul, N. Y.-Southampton...July 4

New York, N. Y.-Southampton...July 11

Atlantic Transport.

Minneapolis, N. Y.-London...July 4

Minnetonka, N. Y.-London...July 11

Cunard.

Saxonia, Boston-Liverpool...June 30

Campania, N. Y.-Liverpool...July 1

Etruria, N. Y.-Liverpool...July 4

Caronia, N. Y.-Liverpool...July 11

French Line.

La Loraine, N. Y.-Havre...July 2

La Touraine, N. Y.-Havre...July 9

Holland-American.

Rotterdam, N. Y.-Rotterdam...July 1

New Amsterdam, N. Y.-Rot m...July 8

North German Lloyd.

Kaiser Wm. de Grosse, N. Y.-

Bremen...June 30

Kronprinzessin, N. Y.-Bremen...July 7

White Star.

Oceanic, N. Y.-Southampton...July 1

Celtic, N. Y.-Liverpool...July 1

Republic, Boston-Liverpool...July 4

Teutonic, N. Y.-Southampton...July 8

Baltic, N. Y.-Liverpool...July 9

Red Star.

Finland, N. Y.-Antwerp...July 4

Vaderland, N. Y.-Antwerp...July 11

Hamburg-American.

Hamburg, N. Y.-Hamburg...June 30

Amerika, N. Y.-Hamburg...July 2

the flowers grown by Mr. Meyer at Dalton, a suburb on the south side.

NEW RETAIL FLOWER STORES.

Edeffsen-Leideger Co., 782 Third street, Milwaukee, Wis.

Ed. Eisner, for 15 years with Chas Samuelson, is opening a new store at 5523 S. Halstead St.

Bethlehem, Pa., held its first floral show on June 19, and among the many exhibits that of John E. Haines, the noted carnation specialist, was notably attractive, both in artistic arrangement and variety of choice plants and flowers. Jacob A. Eyres displayed a variety of palms, and first prizes were awarded to both gentlemen.

JOHN BREITMEYER'S SONS

Cor. Miami and Gratiot Aves.
DETROIT, MICH.

Artistic Designs . . .
High Grade Cut Blooms

We cover all Michigan points and good sections of Ohio, Indiana and Canada

William J. Smyth FLORIST

Cor. Michigan Ave. and 31st St., CHICAGO

We ship to all points in Illinois and Iowa.

Phones: Douglas 744, Douglas 523, Douglas 740

M. C. and J. E. HAUSWIRTH

232 Michigan Ave.

CHICAGO

AUDITORIUM ANNEX Tel. Harrison 585

SAMUEL MURRAY Florist

Coates House Conservatory

1017 BROADWAY, KANSAS CITY, MO

Both 'Phones 2670 Main

FRED C. WEBER FLORIST

4326-28 ST. LOUIS, MO.
OLIVE STREET

Established 1873
Long Distance Phone Bell Lindell 676



WASHINGTON,
D. C.

GUDE'S

The Far-Famed Flowers of
TORONTO

Delivered on mail or telegraph order for any occasion, in any part of the Dominion.

JOHN H. DUNLOP,
96 Yonge St., Toronto, Ont.

The **Park Floral Co.**

J. A. VALENTINE
Pres.

DENVER, COLORADO

WILLIAM L. ROCK FLOWER CO.

KANSAS CITY, MO.

will carefully execute orders for Kansas City and any town in Missouri or Kansas.

H. BAYERSDORFER & CO.

Known to the Trade for the past 30 years as the

Representative Florists' Supply House of America

Always first in the market with anything that is new, novel and appropriate.

FOR THE MONTH OF WEDDINGS AND GRADUATIONS

We have prepared for your needs with a stock of desirable and useful goods, unequalled in quality and extent anywhere on this continent and at prices that cannot be beaten. Orders by mail or telegraph will be filled immediately. Catalogue on application.

H. BAYERSDORFER & CO., 1129 Arch St., Philadelphia

PERSONAL.

Visitors in New York: D. B. Long, Buffalo; W. F. Kasting, Buffalo; W. W. Castle, Boston.

Frank Saunders has taken the position of manager of the Bedford Park Floral Co., Toronto, Can.

Walter Reimels, of Woodhaven, N. Y., was married to Miss May Specht, of New York city, on June 17.

Edwin H. Cooley has opened the retail store of the Mt. Desert Nurseries, Bar Harbor, Me., for the season.

Harry Hall has left the State College at Durham, N. H., to engage in commercial horticulture at Brighton, Mass.

Wm. T. Bell, Franklin, Pa., sailed from Quebec on S. S. Empress of Britain, June 12, for a visit to England.

T. Mellstrom, representing Sander & Son, St. Albans, Eng., sailed on June 24 on the S. S. Deutschland for Europe.

August E. Baumer, of Louisville, Ky., was married on the evening of June 11 to Miss Jessie Lauser, of the same city.

George Hunter, a florist, who has spent the past year in Australia and New Zealand, has returned to New Haven, Conn.

Mrs. E. A. Anderson, who has a flower store at 14 Colorado avenue, Chicago, has lately married and the new sign reads Mrs. Wells. She will continue the business as before.

Visitors in Boston: Mrs. C. B. Whitnall, Milwaukee, Wis.; T. Mellstrom, representing Sander & Son, St. Albans, Eng.; Mr. and Mrs. Walter Reimels, Andrew R. Kennedy, gardener for Dr. L. D. Ward, Madison, N. J.

Visitors in Chicago: Theodore Thurston, Kalamazoo, Mich.; A. L. Glaser, Dubuque, Ia.; Fred Chapman, of Clinton Falls Nursery Co., Owatonna, Minn.; O. F. Brant, Faribault, Minn.; J. B. Baker, of Baker Bros., Fort Worth, Texas.

Miss N. C. Moore, of N. C. Moore & Co., Morton Grove, Ill. is recovering from illness. Miss Moore has a

stand in the Cut Flower Exchange and her father has charge of the greenhouses. They are making arrangements to go into the plant business.

J. W. Adams, the veteran nurseryman and florist of Springfield, Mass., celebrated on June 20 his 80th birthday. Mr. Adams feels that time has dealt very kindly with him. He is active and alert, mentally and physically and we hope the coming years will be equally lenient and that he may continue long to adorn the profession to which he has devoted his life.

PERSONAL ITEMS FROM MADISON, N. J.

Rumor has it that Wm. Duckham intends to sail for Europe for a three months' vacation. The good wishes of all will go with him.

C. H. Totty is turning out chrysanthemums and roses to the trade by the truck load. There seems to be no "hard times" around him.

R. M. Schultz has rented his greenhouses on Rosedale avenue and has become identified with Vaughan's Seed Store as traveling solicitor.

A. R. Kennedy leaves on his vacation soon for a few weeks and no doubt will have a number of interesting things to tell us when he gets back.

Percy Herbert, president, of the Florists' Society, left last Saturday for Scotland, with his family. He expects to be away ten or twelve weeks and will see all he can of Scotland, England and maybe some of Ireland.

E. R.

INCORPORATED.

Stevens Bros., Trenton, N. J.; W. K. C. S. and G. W. Stevens; capital, \$100,000.

Loziers, to engage in nursery and floral business; A. G., H. E. and M. I. Lozier; capital, \$25,000.

William C. Smith Wholesale Floral Co., St. Louis, Mo.; W. C. Smith, Ch. Smith, W. H. Osseck; capital, \$50,000.

Fulton Botanical Gardens, Fulton, N. Y.; to cultivate roots, herbs, plants, etc.; I. C. Curtis, A. G. Gilbert, E. J. Penfield; capital, \$10,000.

PROMPT DELIVERY IN BOSTON

AND ALL NEW ENGLAND POINTS
HOUGHTON & CLARK
396 Boylston St., Boston, Mass.



BOSTON'S BEST

In Quality and Design

Can be relied upon when you transfer your retail orders to

EDWARD MACMULKIN
194 Boylston Street, Boston

Send flower orders for delivery in **BOSTON**

and all **NEW ENGLAND POINTS**
THOS. F. CALVIN
124 Tremont St., Boston

TRANSFER

Your orders for flower or plant delivery in Eastern New England to

JULIUS A. ZINN,
2 Beacon St., Boston.
Fine Design Work a Specialty

Wired Toothpicks

Manufactured by

W. J. COWEE, BERLIN, N. Y.
10,000...\$1.75; 50,000...\$7.50. Sample free.
For sale by dealers

WEIGEL & UJFALUSSY

Successors to Emil Steffens

Manufacturers of Florists' Wire Designs and Supplies. Established 1866.
136-138 W. 28th St., New York City
Telephone 1922 Madison Sq.

Anything in the line of wire work and designs not listed in our catalog will be made up promptly on short notice.

You will find something worth reading on every page of HORTICULTURE.

BRONZE GALAX NONE BETTER

\$1.00 per 1000. \$7.50 per case (of 1071)

DACGER FERNS

\$1.00 per 1000

The Leo Niessen Company
1209 Arch St., Philadelphia, Pa.
After June 27th Store closes 6 p. m.

ADVERTISE

There is a good Customer somewhere for every good thing you have to offer. *Horticulture* can help you to find him * * *

ADVERTISE

EVERYTHING SEASONABLE IN
CUT FLOWERS
EDWARD REID, Wholesale Florist
1526 Ranstead St., PHILADELPHIA
STORE CLOSES 8 P. M.

CUT FLOWER BOXES
EDWARDS FOLDING BOX CO
MANUFACTURERS
PHILADELPHIA, PA.

CHAS. W. MCKELLAR

51 WABASH AVE., CHICAGO

Western Headquarters for Choice Orchids
Valley, Roses and all Cut Flowers

PETER REINBERG
WHOLESALE

CUT FLOWERS

51 Wabash Av., Chicago, Ill.

AMERICAN BEAUTY and all other ROSES
LILY OF THE VALLEY, CARNATIONS
WELCH BROS., 226 Devonshire St., Boston, Mass.

SWEET PEAS

Never Better than at Present
PERFECT IN COLOR, SUBSTANCE and STEEL
W. E. MCKISSICK WHOLESALE FLORIST
PHILADELPHIA
1619-1621 RANSTEAD ST.

DAILY CONSIGNMENTS

From 40 to 60 Growers
We can care for your cutflower wants to advantage.
E. F. WINTERSON CO.
45-47-49 WABASH AVE., CHICAGO

Rice Brothers

115 N. 6th Street, MINNEAPOLIS, MINN.
WHOLESALE FLORISTS and SUPPLIES
CUT FLOWERS received twice daily, and can fill your orders to your satisfaction. A complete line of Hardy Greens—WILD SMILAX, BOXWOOD, HARDY FANCY FERNS, GALAX LEAVES.
Write for quotations on large quantities.

E. A. BEAVEN
Southern Wild Smilax,
Log Mosses,
Natural and Perpetuated—at Wholesale
EVERGREEN, ALABAMA.

TOWER HOTEL

Niagara Falls, N. Y.
Is soliciting your patronage during the S. A. F. Convention.
Very truly yours,
M. J. HOENIG, Prop.

WHOLESALE FLOWER MARKETS—TRADE PRICES—Per 100 TO DEALERS ONLY

	CHICAGO June 24	TWIN CITIES June 24	PHILA. June 24	BOSTON June 25
ROSES				
Am. Beauty, Fancy and Special...	25.00 to 35.00	25.00 to 35.00	18.00 to 25.00	15.00 to 25.00
" Ex.ia.....	18.00 to 20.00	18.00 to 20.00	10.00 to 15.00	12.00 to 15.00
" No. 1.....	12.00 to 15.00	12.00 to 15.00	6.00 to 8.00	8.00 to 10.00
" Lower grades.....	6.00 to 10.00	6.00 to 10.00	2.00 to 5.00	1.00 to 4.00
Bride, "Maid, Fancy & Special....	5.00 to 8.00	3.00 to 8.00	4.00 to 6.00	4.00 to 6.00
" Lower grades.....	3.00 to 5.00	3.00 to 5.00	1.00 to 2.00	.50 to 1.00
Killarney, Richmond, Fan, & Sp...	8.00 to 10.00	8.00 to 10.00	5.00 to 8.00	4.00 to 6.00
" Lower grades.....	5.00 to 7.00	5.00 to 7.00	1.00 to 3.00	.50 to 4.00
Chatenay, Fancy and Special.....	6.00 to 8.00	6.00 to 8.00	5.00 to 6.00	4.00 to 6.00
" Lower grades.....	4.00 to 6.00	4.00 to 6.00	2.00 to 3.00	.50 to 3.00
Kaiserin, Carnot.....	6.00 to 8.00	6.00 to 8.00	3.00 to 4.00	8.00 to 6.00
Golden Gate Ivory.....	4.00 to 7.00	4.00 to 7.00	2.00 to 6.00	.50 to 4.00
CARNATIONS				
Fancy and Novelties.....	1.50 to 3.00	1.50 to 3.00	1.50 to 2.00	1.00 to 2.00
Ordinary.....	1.00 to 1.50	1.00 to 1.50	.75 to 1.00	.30 to 1.00
MISCELLANEOUS				
Cattleyas.....	40.00 to 50.00	40.00 to 50.00 to 50.00	40.00 to 50.00
Lilies.....	6.00 to 10.00	6.00 to 10.00 to 10.00	3.00 to 5.00
Lily of the Valley.....	3.00 to 4.00	3.00 to 4.00	2.00 to 4.00	1.00 to 3.00
Daisies.....	.25 to 1.00	.25 to 1.00 to .50	1.00 to 1.00
Pansies.....	.25 to .50	.25 to .50 to .25	.25 to .50
Peonies.....	3.00 to 6.00	3.00 to 6.00	3.00 to 5.00	2.00 to 4.00
Gladioli.....	10.00 to 12.00	10.00 to 12.00	3.00 to 5.00	2.00 to 3.00
Mignonette.....	1.00 to 3.00	1.00 to 3.00 to 1.00	1.00 to 2.00
Gardenias..... to to	15.00 to 20.00	12.00 to 25.00
Sweet Peas.....	.75 to 1.00	.75 to 1.00	.25 to .75	15 to .50
Adiantum.....	1.00 to 1.50	1.00 to 1.50	1.00 to 1.50	1.00 to 1.50
Smilax.....	10.00 to 15.00	10.00 to 15.00	15.00 to 20.00	10.00 to 12.00
Asparagus Plumosus, strings.....	40.00 to 60.00	40.00 to 60.00 to 50.00	25.00 to 50.00
" " & Sprea. (100 bchs.)	15.00 to 25.00	15.00 to 25.00	35.00 to 50.00	15.00 to 50.00

J.A. BUDLONG

37-39 Randolph Street, CHICAGO.

Roses and Carnations WHOLESALE CUT FLOWERS
A Specialty..... GROWER of

ROBERT J. DYSART,
Public Accountant and Auditor
Simple methods of correct accounting especially adapted for florists' use.
Books Balanced and Adjusted
Merchants Bank Building
28 STATE ST., BOSTON
Telephone, Main 58

J. B. Murdoch & Co.
Wholesale Florists
FLORISTS' SUPPLIES
714 Penn Ave., PITTSBURG, PA.
Long Distance Phone 1435 Court.

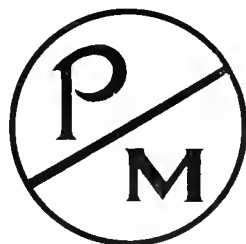

When You See This Label
Quality is Guaranteed

SPECIAL OFFERING FOR THIS WEEK

CHIFFONS

The Best Quality

COLORS: American Beauty, Violet, Purple, Green, Nile, Foliage, Yellow and White.

PRICES

PLAIN	DOTTED
4 in., 3c per yd.	4 in., 4½c per yd.
6 in., 4c " "	6 in., 5½c per yd.
10 in., 7c " "	

Pieces contain about 35 yards each.

S. S. PENNOCK-MEEHAN CO., "THE" PHILA.
WHOLESALE FLORISTS

1608 to 1620 Ludlow Street—Store Closes 6 P. M. After June 27th.

FLOWER MARKET REPORTS

BOSTON

Business is fairly satisfactory this week. White roses, American Beauty and lily of the valley are having a good call. The quality of white roses, unfortunately, is not good. Kaiserin is all right but there are not enough of them and Bride is the main reliance. Much complaint is made by the retailers of the quality of the latter, but it is the same every year at this season and nobody can help it. Carnot roses are good. It is a wonder that more of this reliable summer rose and the equally desirable Kaiserin are not grown. There is a good market for them. Good Killarneys are also short of the demand. Carnations are abundant and prices are down to the lowest notch. If fancy grades could be obtained they would find a good sale but most of the carnations are in bad shape and the growers might just as well throw them out.

BUFFALO

Stock of all kinds has been plentiful for the past two weeks, especially carnations, for which the demand has been light; Lawson, Victory and Windsor are of good quality; too much ordinary and small-bloom stock drag along from day to day. The severe warm weather has shut off the supply of good Fridesmaid and Bride roses and much of this stock is mildewed. Kaiserin, Carnot, Killarney and Richmond are in ample supply and sell readily. Peonies have had their inning and are over with. Spanish iris in colors of purple, white and yellow are in and sell well. Longiflorum and Japan lilies are in good supply and at times need a little urging to move. Pans, mostly outdoor, are coming in heavily. Graduations and school commencements are in order the coming week and a good lively week's business is looked for with both the wholesaler and retailer.

CHICAGO

There has been quite a shortage in tea roses recently, which has a tendency to cause quite an advance in price of good stock. There is also quite a shortage in good strings of Asparagus plumosus, everything of good quality going quickly. Field daisies are not so common in this vicinity as in the New England States, but the fields at Clarendon Hill about twenty miles west have produced an abundance lately, one firm having sold

170,000 last week. The cool weather of last week has been followed by torrid weather this week, the temperature at this writing being in the nineties. If this weather continues a few days longer it will take the quality out of the flowers and the life out of trade.

INDIANAPOLIS

June has brought an unprecedented demand for stock for weddings and school closings. Beauties are about the best flower now on the market. Carnations are rapidly going out. Outside sweet peas are available in great quantities and fill the major portion of the demand for small flowers. Hydrangeas remain about the only good offering in the way of a pot plant. Some fine lilies and gladioli have been on the market. There seems to be quite a lively demand for asparagus plumosus and smilax, while call for other greens is light. Judging by the reports the present season has been one of the best on record in every line.

NEW YORK

The early part of the present week was brightened up by a noticeable revival of activity which gave encouragement to the hope that it might forecast a permanent improvement, but past experience has shown the futility of planning for any steady business at this season, and it is the expectation of those who have been through similar experiences before that a lay or two will mark the limit of the present spurt. In the meantime the supply is rapidly shortening up and quality, under the blazing weather conditions, is "on the toboggan." Peonies and other outdoor material have practically disappeared, leaving the field to the weakened greenhouse product.

PHILADELPHIA

Supplies of flowers have shortened up considerably, not only locally but at shipping distances.

thus causing an extra demand from outside which has made business appear to be better than the previous week, although when figures were totaled for the week, the results were found not quite as good. Tea roses moved in better shape and were one of the most satisfactory subjects in the week's business, especially in good quality grades which were very scarce. The so-called "Summer Beauties" and Kaiserins are now very much in evidence and are one of the best features of the market. Good carnations are very scarce but about anything near average finds a ready market. Sweet peas are now in much larger receipts and sluggish demand. Cattleya Gaskelliana is the reigning favorite in orchids. C. Mossiae about over for the season. Lily of the valley continues of fine quality and the demand is better. Retarded peonies are about over, although a much larger stock than usual was put into storage here a month ago. This is a pointer for next year. Peonies would sell for a month yet.

ON THE ALLEYS.

At the last practice game of the New York bowlers only three of the twelve contestants succeeded in reaching the coveted average of 155, viz.: Chadwick 183, Fenrich 171 and Schreiner 167. Four games were played, the highest score in any one game being 205 by Chadwick.

About fifteen of the Baltimore florists journeyed to Washington on the 26th, for a match game at bowling, and were entertained sumptuously by the Washington bowlers at the Royal bowling alleys. The following is the score for three games:

BALTIMORE.	WASHINGTON	
Parry	Shaffer	526
Moss	Simmonds	421
Lehr	McCully	393
Richmond	Campbell	529
Spehold	McLennan	461
Kuerst	Barry	459

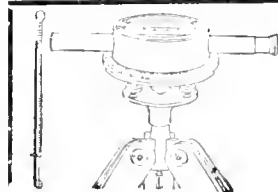

Bostrom Improved Builders' Levels and Farm Levels

For Park, Cemetery and Landscape Gardening use, take the place of expensive Engineering Instruments. Simple in construction, easily adjusted, more substantial and less cumbersome than the more elaborate and complicated instruments. Practical, up-to-date instrument that any one can use. Write for descriptive circulars and be convinced that this Level is necessary to complete your outfit. Builders' Level \$25.00. Farm Level \$12.50.

BOSTROM-BRADY MFG. CO., 139 Madison Avenue, ATLANTA, GA

FORD BROTHERS
 48 West 28th Street, NEW YORK
FINE ROSES FANCY CARNATIONS
 A Full Line of All CUT FLOWERS
 Telephone, 3870 or 3871 Madison Square

H. E. FROMENT,
 Wholesale Commission Florist,
 Choice Cut Flowers,
 37 West 28th St., :: NEW YORK.
 Telephones: 2200, 2201, Madison Square.

The Reliable Commission House
 Richmond Roses and Rich Flowers
 of all varieties
JOS. S. FENRICH
 110 W. 28th Street, New York
 Tel. 324-325 Madison Square

Alfred H. Langjahr
 All choice cut-flowers in season. Send
 for quotations. Correspondence with
 shippers of first-class stock invited.
 55 West 28th Street, New York.
 Telephones 4626-4627 Madison Square

Edward C. Horan
 Wholesale Florist
 55 WEST 28th ST.
 Tel. 1462 Madison Square New York
 1463

JOHN I. RAYNOR
Wholesale Commission Florist SELLING AGENT FOR
 LARGEST GROWERS
 A full line of Choice Cut Flower stock for all purposes. Comprises every variety
 grown for New York market, at current prices
 TEL. 1998 MADISON SQUARE 49 W. 28 St., New York City

Walter F. Sheridan
 Wholesale Commission Dealer in
CHOICE CUT FLOWERS
 39 West 28th Street, New York
 Telephone: 3532-3533 Madison Square

HEADQUARTERS FOR NOVELTIES
ORCHIDS A SPECIALTY
 THE HIGHEST GRADE OF **VALLEY** ALWAYS ON HAND
 GARDENIAS, DAISIES, ROSES AND CARNATIONS
JAMES McMANUS, Telephone 759 Mad. Sq. 42 W. 28th St., New York

PHILIP F. KESSLER 55 & 57 W. 26th St., New York City
 Commission Dealer, Wholesale Buyer
 and Seller of
CUT FLOWERS
 Open from 5 a. m. to 6 p. m. Sunday
 till 10 a. m.
 Tel. 5243 and 2921 Madison Sq. Res., 345 J., Newtown,
Finest Lilies in the Market Every Day in the Year.

Alexander J. Guttman
THE WHOLESALE FLORIST OF NEW YORK
 34 WEST 28th STREET
 PHONES. 1664--1665 MADISON SQUARE
ENOUGH SAID

NEW YORK QUOTATIONS PER 100—TO DEALERS ONLY

	Last Half of Week ending June 20 1908		First Half of Week beginning June 22 1908		Last Half of Week ending June 20 1908		First Half of Week beginning June 22 1908	
Roses								
Am. Beauty, fan and sp.	6.00	to 15.00	6.00	to 15.00				
" extra	5.00	to 6.00	4.00	to 6.00				
" No. 1	2.00	to 4.00	2.00	to 4.00				
" Lower grades50	to 1.00	.50	to 1.00				
Bride, 'Maid, fan and sp.	3.00	to 5.00	3.00	to 5.00				
" lwr. grds.50	to 1.00	.50	to 1.00				
Kill rney, Richmond, tancy & spec	3.00	to 6.00	4.00	to 5.00				
" " lower grades.50	to 2.00	.50	to 2.00				
Chatenay, Fancy and Special.	3.00	to 5.00	3.00	to 5.00				
" Lower grades50	to 2.00	.50	to 2.00				
Kaiseno, Carnct.50	to 4.00	.50	to 6.00				
Golden Gate, Ivory.50	to 4.00	.50	to 3.00				
Carnations, Fancy and Novelties.	1.00	to 1.50	.75	to 1.50				
" Ordinary30	to .50	.25	to .50				
Cattleyas	25.00	to 50.00	25.00	to 50.00				
Lilies	3.00	to 5.00	2.00	to 4.00				
Lily of the Valley	1.00	to 3.00	1.00	to 3.00				
Daisies25	to .50	.25	to .50				
Pansies15	to .50	.25	to .50				
Peonies	1.00	to 6.00	1.00	to 6.00				
Gladioli	4.00	to 8.00	4.00	to 8.00				
Lignonette50	to 1.00	.50	to 1.00				
Gardenias	15.00	to 25.00	3.00	to 20.00				
Sweet Peas per 100 bunches	3.00	to 6.00	1.50	to 4.00				
Adiantum25	to .50	.25	to .50				
Smilax	8.00	to 12.00	6.00	to 10.00				
Asparagus Plumosus, strings	15.00	to 25.00	10.00	to 20.00				
" " & Sprea. (100 bchs.)	15.00	to 25.00	10.00	to 20.00				

Moore, Hentz & Nash,
 Wholesale Commission Florists,
 55 and 57 West 26th Street,
 Telephone No. 756
 Madison Square. New York.

TRAENDLY & SCHENCK
WHOLESALE FLORISTS
 Furnish best stock at fair prices all the year round Send for quotations on fall orders
 Tel. 798.799 Madison Sq. 44 West 28th Street, New York City

REED & KELLER
 122 West 25th St., New York
Florists' Supplies
 We manufacture all our
 Metal Designs, Baskets, Wire Work & Novelties
 and are dealers in
 Glassware Decorative Greens and Florists' Requisites

☞ The advertisers on this page do business
 the whole year round. If you have flowers
 to consign this is worth remembering.



HARDY CUT FERNS

1000. BOXWOOD, per bunch 35c, 50 lbs. \$7.50. Sphagnum Moss, Extra Large Bales, per bale, \$1.25. Fancy and Dagger Ferns our specialty. A trial order will convince you that we ship only first-class stock. Headquarters for Florists' supplies and wire work. All cut flowers in season.

MICHIGAN CUT FLOWER EXCHANGE, INC., All 'phone connections 38-40 Broadway, Detroit, Mich.

FANCY and DAGGER

Extra fine, \$1.00 per 1000. Bronze and Green Galax, \$1.25 per 1000, \$8.50 case of 10,000. Leucothoe Sprays, \$1.00 per 100. \$7.50 per

Headquarters in Western New York

FOR

ROSES, CARNATIONS

And all kinds of Seasonable Flowers

Wm. F. Kasting Co.

Wholesale Commission Florist, also Dealer in Florists' Supplies and Wire Designs.

383-87 ELLICOTT ST. BUFFALO, N. Y.

Give us a trial. We can please you.

FRANK S. HICKS & CO.

Wholesale Florists.

Open Now for Consignments of Cut Flowers.

39 West 28th Street, - New York City

Tel. 2920 Mad. Sq.

WILLIAM H. KUEBLER

Brooklyn's Foremost and Best

WHOLESALE COMMISSION HOUSE

A First Class Market for all CUT FLOWERS

28 Willoughby St., Brooklyn, N. Y.

Tel. 4591 Maic



Henry M. Robinson & Co.

Wholesale and Commission
FLORISTS



Hardy Cut Evergreens and Florists' Supplies

NEW CROP DAGGER AND FANCY FERNS, \$2.00 per M.

15 Province St. and 9 Chapman Place, Boston, Mass.

Flowers and Florists' Supplies

The best place in AMERICA to buy

BAY TREES

N. F. McCarthy & Co.

84 Hawley St., BOSTON, MASS.

Largest Dealers in Supplies in New England.

SAMUEL A. WOODROW

WHOLESALE PLANTSMAN

Palms, Large and Small Ferns, etc.

53 West 30th Street, NEW YORK

Telephona 2083 Madison

In ordering goods please add "I saw it in HORTICULTURE."

BOSTON FLORIST LETTER CO.
Manufacturers of FLORISTS' LETTERS

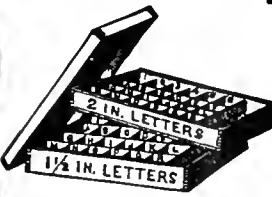

This wooden box nicely stained and varnished, 18x30x12, made in two sections, one for each size letter, given away with first order of 500 letters

Block Letters, 1½ or 2 inch size per 100, \$3. Script Letters, 3. Fastener with each letter or word. Used by leading florists everywhere and for sale by all wholesale florists and supply dealers

N. F. McCARTHY, Manager
66 Pearl Street, BOSTON, MASS.

WHOLESALE FLOWER MARKETS. — PER 100. — TO DEALERS ONLY.

	CINCINNATI June 23	DETROIT June 22	BUFFALO June 24	PITTSBURG June 24
ROSES				
Am. Beauty, Fan. and Sp.....	20.00 to 25.00	25.00 to 35.00	25.00 to 25.00	20.00 to 25.00
" Extra.....	15.00 to 20.00	18.00 to 20.00	15.00 to 20.00	10.00 to 15.00
" No. 1.....	8.00 to 10.00	12.00 to 15.00	8.00 to 15.00	4.00 to 8.00
" Lower grades.....	4.00 to 6.00	6.00 to 10.00	3.00 to 5.00	2.00 to 3.00
Bride, 'Maid, F. & S.....	5.00 to 6.00	5.00 to 8.00	6.00 to 8.00	6.00 to 8.00
" " Low gr.....	2.00 to 4.00	3.00 to 5.00	2.00 to 6.00	2.00 to 4.00
Killarney, Richmond, Fan. & Sp.....	6.00 to 8.00	3.00 to 10.00	6.00 to 8.00	6.00 to 10.00
" " Lower grades.....	2.00 to 4.00	5.00 to 7.00	2.00 to 6.00	2.00 to 4.00
Chatenay, Fancy and Special.....	6.00 to 8.00	6.00 to 8.00	6.00 to 8.00	6.00 to 10.00
" Lower grades.....	3.00 to 4.00	4.00 to 6.00	2.00 to 6.00	2.00 to 4.00
Kaiserin, Carnot.....	5.00 to 8.00	6.00 to 8.00	3.00 to 7.00	2.00 to 10.00
Golden Gate, Ivory.....	5.00 to 8.00	4.00 to 7.00	2.00 to 5.00	2.00 to 10.00
CARNATIONS				
Fancy and Novelties.....	2.00 to 3.00	1.50 to 3.00	1.50 to 2.00 to 2.00
Ordinary.....	1.00 to 2.00	1.00 to 1.50	1.00 to 1.50	75 to 1.00
MISCELLANEOUS				
Cattleyas.....	40.00 to 50.00	40.00 to 50.00	40.00 to 50.00 to 75.00
Lilies.....	8.00 to 10.00	6.00 to 10.00	10.00 to 12.00	8.00 to 12.50
Lily of the Valley.....	3.00 to 4.00	3.00 to 4.00	2.00 to 4.00	3.00 to 4.00
Daisies.....	.35 to .50	.25 to 1.00	.50 to 1.50	.50 to 1.50
Pansies.....	.25 to .35	.25 to .50	.30 to .50	.50 to .75
Peonies.....	2.00 to 4.00	3.00 to 6.00	2.00 to 5.00	3.00 to 4.00
Gladioli..... to 4.00	10.00 to 12.00	3.00 to 5.00 to 5.00
Mignonette.....	1.00 to 2.00	1.00 to 3.00	1.00 to 2.00 to 2.00
Gardenias.....	1.00 to 2.00 to 2.00	25.00 to 35.00	15.00 to 20.00
Sweet Peas.....	.50 to .75	.75 to 1.00	.40 to .75	.25 to .75
Adiantum.....	.50 to .75	1.00 to 1.50	.50 to 1.50 to 1.25
Smilax..... to 1.00	10.00 to 15.00 to 15.00	12.50 to 15.00
Asparagus Plumosus, strings.....	40.00 to 50.00	40.00 to 60.00	50.00 to 60.00	25.00 to 50.00
" " & Sprea. (100 bchs.)..... to 25.00	15.00 to 25.00	35.00 to 50.00	25.00 to 50.00

H. C. BERNING

Wholesale Florist

1402 Pine Street, ST. LOUIS, MO.

MILLANG BROS.

WHOLESALE COMMISSION FLORISTS

41 West 28th Street

Telephones 3880 Madison 3881

NEW YORK

A. MOLTZ

Will purchase flowers on order in N. Y. market and ship carefully at prevailing wholesale prices. Address

755-57 West 26th Street, New York City

CLEARY'S HORTICULTURAL CO.

Management AMBROSE T. CLEARY

Wholesale Contracting, Jobbing, Auction HORTICULTURAL PRODUCTS of every description.

Consignments Received. Surplus Stock Converted. 62 Vesey St., NEW YORK

In writing to Advertisers kindly mention Horticulture

Buyer's Directory and Ready Reference Guide

Advertisements under this head, one cent a word. Initials count as words.

Regular advertisers in this issue are also listed under this classification without charge. Reference to List of Advertisers will indicate the respective pages.

Buyers failing to find what they want in this list will confer a favor by writing us and we will try to put them in communication with reliable dealers.

ACCOUNTANT

R. J. Dysart, 28 State St., Boston.
For page see List of Advertisers

AGERATUMS

Age 10m Blue Perfection, in bud and bloom, 2 1/2-in. pots, \$2.00 per 100; 3-in., \$3.00 per 100. Reznald Pratt, Wayne, Pa.

ARAUCARIAS

A. Leuthy & Co., Perkins St. Nurseries, Roslindale, Mass.

For page see List of Advertisers.

Godfrey Aschmann, 1012 West Ontario St., Philadelphia, Pa.

For page see List of Advertisers.

We have a specially fine lot of Araucarias, the plants at \$1.00 each are extra value for the money.

4 inch..... 50 cents each
5 "..... 75 " " "
6 "..... \$1.00 each
Witbold Co., 1657 Buckingham Place, Chicago, Ill.

ASPARAGUS

A. N. Pierson, Cromwell, Conn.
Asparagus Plumosus Seedlings.
For page see List of Advertisers.

J. M. Thorburn & Co., 33 Barclay St., New York.

Plumosus Robustus Seeds
For page see List of Advertisers.

Asparagus Plumosa, 2 in. pots. Fine plants, \$2.50 per 100; \$20.00 per 1000. Cash with order or good reference. Erle Floral Co., Erie, Pa., or, Wm. F. Kasting Co., 385 Elliott St., Buffalo, N. Y.

ASTER SEED

Altimo Culture Co., Canfield, O.
For page see List of Advertisers.

AUCTION SALES

Cleary's Horticultural Co., 62 Vesey St., New York.
For page see List of Advertisers.

AZALEAS

A. Leuthy & Co., Perkins St. Nurseries, Roslindale, Mass.

For page see List of Advertisers.

August Rolker & Sons, New York, 31 Barclay St., or, P. O. Box 752.

For page see List of Advertisers.

BAMBOO CANES

Yokohama Nursery Co., 31 Barclay Street, New York.

For page see List of Advertisers.

BAY TREES.

N. F. McCarthy & Co., 84 Hawley St., Boston.

For page see List of Advertisers.

Godfrey Aschmann, 1012 West Ontario St., Philadelphia, Pa.

For page see List of Advertisers.

2000 Bay and Box Trees in all sizes, Pyramid and Standards. Write for list. Julius Roehrs, Rutherford, N. J.

BEDDING PLANTS

R. Vincent, Jr., & Sons Co., White Marsh, Maryland.

For page see List of Advertisers.

A. N. Pierson, Cromwell, Conn.
For page see List of Advertisers.

A. Leuthy & Co., Perkins St. Nurseries, Roslindale, Mass.

For page see List of Advertisers.

BEDDING PLANTS - Continued

F. R. Pierson Co., Tarrytown-on-Hudson, N. Y.

For page see List of Advertisers.

Vern L. Schiraff, Erie, Pa.

For page see List of Advertisers.

Godfrey Aschmann,

1012 W. Ontario St., Phila., Pa.

For page see List of Advertisers.

40,000 geraniums, 10 best standard sorts; 5000 Vinca variegata; Salvia; heliotrope, dark; feverfew, double white. Good stock, prices right. E. D. Kaulback & Son, Malden, Mass.

BEGONIAS

Thomas Roland, Nahant, Mass.

Gloire De Lorraine.

For page see List of Advertisers.

S. S. Skidelsky, 1741 N. 18th St., Phila.
Gloire de Lorraine.

For page see List of Advertisers.

R. Vincent, Jr. & Sons Co.,

White Marsh, Md.

For page see List of Advertisers.

Begonia Gloire Lorraine, strong plants from leaf cuttings, 2 1/4 inch pots, \$12.00 per 100; \$110.00 per 1000. Julius Roehrs, Rutherford, N. J.

BOILERS

BOILERS. "Burnham" Boilers made for greenhouse heating. Lord & Burnham, 1133 Broadway, N. Y.

Kroeschell Bros. Co., 35 Erie St., Chicago.
For page see List of Advertisers.

BUILDERS' AND FARM LEVELS

Bostrom-Brady Mfg. Co., 129 Madison Ave., Atlanta, Ga.
For page see List of Advertisers.

BUILDING MATERIAL

BUILDING MATERIAL of all description for All Cypress, Semi-Iron, Iron Frame or Truss Houses. Hot Bed Sash and Frames. Lord & Burnham Co., 1133 Broadway, N. Y.

BULBS AND TUBERS

Joseph Breck & Sons, 47-54 N. Market St., Boston.

For page see List of Advertisers.

J. M. Thornburn & Co., 33 Barclay St., New York.

Lillium Harrisii.

For page see List of Advertisers.

A. T. Boddington, 342 W. 14th St., N. Y.
Cold Storage Lily Bulbs.

For page see List of Advertisers.

Rickards Bros., 37 East 19th St., New York.
For page see List of Advertisers.

H. F. Mitchell Co., Philadelphia.

For page see List of Advertisers.

H. E. Flske Seed Co., Faneuil Hall Bq., Boston.

For page see List of Advertisers.

James Yick's Sons, Rochester, N. Y.

Fall Bulbs.

For page see List of Advertisers.

Aug. Rolker & Sons, 31 Barclay St., New York.

Seasonable Import Plants and Bulbs.

For page see List of Advertisers.

K. Velthuis, Hillegom, Holland,
Represented by Felix Bosch, 260 Clarendon St., Boston.

Bulbs French and Dutch.

For page see List of Advertisers.

A. Mitting, 17-23 Kennan St., Santa Cruz, California.

Calla Bulbs.

For page see List of Advertisers.

BULBS AND TUBERS - Continued

Lilium Canadense both red and yellow, and Philadelphicum and other native bulbs. Also native tree and plant seeds. I have them and will make prices to suit. L. E. Williams, Nottingham, N. H.

CANNAS

The Conard & Jones Co., West Grove, Pa.
For page see List of Advertisers.

Godfrey Aschmann,

1012 W. Ontario St., Phila., Pa.

For page see List of Advertisers.

The F. R. Pierson Co., Tarrytown-on-Hudson, N. Y.

For page see List of Advertisers.

CARNATIONS

F. Dorner & Sons Co., Lafayette, Ind.

For page see List of Advertisers.

Chicago Carnation Co., Joliet, Ill.

Field Grown.

For page see List of Advertisers.

John E. Haines, Bethlehem, Pa.

Field Grown.

Carnations Imperial and Pink Imperial.

For page see List of Advertisers.

A. N. Pierson, Cromwell, Conn.

For page see List of Advertisers.

The F. R. Pierson Co., Tarrytown-on-Hudson, N. Y.

For page see List of Advertisers.

Albert Roper, Tewksbury, Mass.

Carnation Bay State.

For page see List of Advertisers.

Carnation cuttings of all the leading varieties at the same price as any reliable firm. Write for prices before you look elsewhere. Wm. F. Kasting Co., 389 Elliott St., Buffalo, N. Y.

CARNATIONS! FIELD GROWN!!

Euchantress and Winsor, on and after July 1st. Only a few left. To close out quick, \$55 a thousand. Cash or good reference with order. Wanoka Greenhouses, Barneveld, N. Y.

50,000 Field Carnations now ready. Long Island grown, standard, \$50.00 per 1000; White Euchantress, Beacon, Winsor, Lloyd, \$10.00 per 100. Cash. Harlowarden Greenhouses, Greenport, N. Y.

CAULIFLOWER AND CABBAGE SEED

H. Hartmann & Co., Copeubagen, Denmark.

For page see List of Advertisers.

CHRYSANTHEMUMS

Chas. H. Totty, Madison, N. J.

For page see List of Advertisers.

A. N. Pierson, Cromwell, Conn.

For page see List of Advertisers.

R. Vincent, Jr., & Sons Co.,

White Marsh, Md.

For page see List of Advertisers.

Frank Gechshin, 2570-2600 W. Adams St., Chicago, Ill.

Pot Chrysanthemums.

For page see List of Advertisers.

Chrysanthemums ready: 2 1/2 inch strong stock of Touset, Oct. Frost, Polly Rose, Wanamaker, and all standards, \$2 per 100, \$18 per M. New: 2 1/2, strong, Alice Roosevelt, Hankey, Clay Frick, Winter Cheer, Rosette, B. May, \$4 per 100, \$30 per M. Cash. Send for catalog. Harlowarden Greenhouses, Greenport, N. Y.

Chrysanthemums, strong, healthy plants, from soil. White, Opah, Geo. S. Kalb, A. Byron, Ivory, P. Rose, Yellow, Rob't. Haliday, Cremo, Pink, Glory of Pacific, Minnie Bailey, best late pink, \$1.25 per 100, \$10.00 per 1000. Cash or C. O. D. D. H. Green, West Grove, Penn.

For List of Advertisers See Page 869

CHRYSANTHEMUMS — Continued

Have 100,000 fine young well-rooted Mums, cuttings of the best 60 commercial varieties. Send for our new and low price list. Satisfaction guaranteed. Wm. Ehmann, Jr., Corfu, N. Y.

Herrington's book on the Chrysanthemum, mailed to your address for 50c., by Horticulture Publishing Co., 11 Hamilton Place, Boston.

COBAEAS

Cobaea scandens from 4 in. pots, \$8.00 per 100. Wittbold Co., 1657 Buckingham Place, Chicago, Ill.

COLEUS

A. N. Pierson, Cromwell, Conn.
For page see List of Advertisers.
R. Vincent, Jr., & Sons Co.,
White Marsh, Md.
For page see List of Advertisers.

CONIFERS

John Waterer & Sons, Ltd., American Nursery, Bagshot, Eng.
For page see List of Advertisers.

CUT FLOWER BOXES.

Edwards Folding Box Co., Philadelphia.
For page see List of Advertisers.
Folding cut flower boxes, the best made. Write for list. Holton & Hunkel Co., Milwaukee, Wis.

CYCLAMEN.

Cyclamen. Best Giant strain, separate colors, once transplanted seedlings, 2c.; twice transplanted, 3c.; strong, from 2-in. pots, 4c. J. L. Schiller, 329 Prouty Ave., Toledo, O.

DAHLIAS

David Herbert & Son, Atco, N. J.
For page see List of Advertisers.
Dahlias, balance of season, 25 named varieties, postpaid, \$1.00. Catalogue free. J. L. Moore, Northboro, Mass.

DECORATIVE PLANTS

A. Leuthy & Co., Perkins St. Nurseries, Roslindale, Mass.
For page see List of Advertisers.
Godfrey Aschmann,
1012 W. Ontario St., Phila., Pa.
For page see List of Advertisers.

DRACAENAS

John C. Hatcher, Amsterdam, N. Y.
For page see List of Advertisers.
Dracaena indivisa: 4 in., \$2.00 per doz., \$12.00 per 100; 5 in., \$3.00 per doz., \$20.00 per 100. Wittbold Co., 1657 Buckingham Place, Chicago, Ill.

ECHEVERIAS

Echeverias, \$18 per 1000, post paid. McDowell, Mexico City.

ELECTRIC CIRCULATOR

The Castle Co., 170 Summer St., Boston.
For page see List of Advertisers.

FERNS

A. Leuthy & Co., Roslindale, Mass.
For page see List of Advertisers.
H. H. Barrows & Son, Whitman, Mass.
Nephrolepis Whitman.
For page see List of Advertisers.
John Scott, Brooklyn, N. Y.
For page see List of Advertisers.
The F. R. Pierson Co., Tarrytown-on-Hudson, N. Y.
For page see List of Advertisers.
Frank Oechlin, 2570-2606 W. Adams St., Chicago.
Ferns for Dishes.
For page see List of Advertisers.

FERNS FOR JARDINIERS

Frank N. Eskesen, Madison, N. J.
For page see List of Advertisers.

FERTILIZERS

Pulverized Manure Co., 31 Union Stock Yards, Chicago, Ill.
Wizard Brand Cattle Manure.
For page see List of Advertisers.
Thoa. J. Grey & Co.,
32 and 33 South Market St., Boston.
High-Grade Scotch Soot.
For page see List of Advertisers.
Wm. Elliott & Sons, 42 Vesey St., New York.
Sterilized Sheep Manure.
For page see List of Advertisers.

FLORAL PHOTOGRAPHS

Floral Photographs. Foley's 226-228 1-2 Bowery, New York.

FLORISTS' BASKETS

E. H. Hitchcock, Glenwood, Mich.

FLORISTS' LETTERS.

Boston Florist Letter Co., 66 Pearl St., Boston, Mass.
For page see List of Advertisers.

FLORISTS SUPPLIES

N. F. McCarthy & Co., 84 Hawley St., Boston.
For page see List of Advertisers.
H. M. Robinson & Co., 15 Province St. and 9 Chapman Pl., Boston, Mass.
For page see List of Advertisers.
Keed & Keller, 122 W. 25th St., New York.
For page see List of Advertisers.
J. B. Murdoch & Co., 714 Penn Ave., Pittsburg, Pa.
For page see List of Advertisers.
H. Bayersdorfer & Co., 1129 Arch St., Philadelphia.
For page see List of Advertisers.

FLOWERS BY TELEGRAPH

Park Floral Co., Denver, Colo.
For page see List of Advertisers.
J. N. Champlin & Co., 1026 Chapel St., New Haven, Conn.
For page see List of Advertisers.
Gude Bros. Co., 1214 F St., Washington, D. C.
For page see List of Advertisers.
Atlanta Floral Co., Atlanta, Ga.
For page see List of Advertisers.
M. C. & J. E. Hauswirth, 232 Michigan Ave., Chicago.
For page see List of Advertisers.
William J. Smyth, Michigan Ave. and 31st St., Chicago.
For page see List of Advertisers.
George Wittbold Co., 1657-59 Buckingham Place, Chicago.
For page see List of Advertisers.
Jacob Schulz, 644 4th Ave., Louisville, Ky.
For page see List of Advertisers.
Thos F. Galvin, 124 Tremont St., Boston.
For page see List of Advertisers.
Julius A. Zinn, 2 Beacon St., Boston.
For page see List of Advertisers.
Houghton & Clark, 396 Boylston St., Boston.
For page see List of Advertisers.
Sidney Hoffman, 59-61 Massachusetts Ave., Boston.
For page see List of Advertisers.
Edward MacMulkin, 194 Boylston St., Boston.
For page see List of Advertisers.
J. Breitmeyer's Sons, Miami and Gratiot Aves., Detroit, Mich.
For page see List of Advertisers.
Samuel Murray, 1017 Broadway, Kansas City, Mo.
For page see List of Advertisers.
Wm. L. Rock Flower Co., 1116 Walnut St., Kansas City, Mo.
For page see List of Advertisers.
Fred C. Weber, 4326-28 Olive St., St. Louis, Mo.
For page see List of Advertisers.
H. G. Eyres, 11 N. Pearl St., Albany, N.Y.
For page see List of Advertisers.
David Clarke's Sons, 2159-2141 Broadway, New York.
For page see List of Advertisers.

FLOWERS BY TELEGRAPH — Continued

Alex. McConell, New York.
For page see List of Advertisers.
Robert G. Wilson, Fulton St. & Greene Av., Brooklyn, N. Y.
For page see List of Advertisers.
Young & Nugent, 42 W. 28th St., N. Y.
For page see List of Advertisers.
J. H. Dunlop, 96 Yonge St., Toronto, Can.
For page see List of Advertisers.

FLOWER POTS

W. H. Ernest, 28th and M Sts., Washington, D. C.
For page see List of Advertisers.
A. H. Hews & Co., Cambridge, Mass.
For page see List of Advertisers.
Hilfinger Bros., Ft. Edward, N. Y.
For page see List of Advertisers.
Red pots, seed pans, etc.
The Peters & Reed Pottery Co., Zanesville, O.

GALAX

Michigan Cut Flower Co., 38 and 40 Broadway, Detroit, Mich.
For page see List of Advertisers.

GERANIUMS

R. Vincent Jr. & Sons Co., White Marsh, Md.
New and Standard Varieties.
For page see List of Advertisers.
500 S. A. Nutt geraniums, 3 and 3 1/2 in. pots, 3 1/2 cents each. Geo. P. Gridley, Wolfboro, N. H.

GLADIOLI

Gladiolus, large flowering mixed, balance of season, \$1.00 per 100; postpaid. J. L. Moore, Northboro, Mass.

GLASS

Boston Plate & Window Glass Co., Boston
For page see List of Advertisers.
Standard Plate Glass Co., 26-30 Sudbury St., Boston.
For page see List of Advertisers.
S. Jacoba & Sons, 1365-79 Flushing Ave., Brooklyn, N. Y.
For page see List of Advertisers.
Metropolitan Material Co., 1398-1408 Metropolitan Ave., Brooklyn, N. Y.
Foley Mfg. Co., Western Ave., between 25th & 26th Sts., Chicago.
Sharp, Partridge & Co., 22d & Lumber St., Chicago.
For page see List of Advertisers.
Greenhouse glass, lowest prices. Johnston Glass Co., Hartford City, Ind.
GLASS, High Grade, Double Thick Greenhouse Glass. Lord & Burnham, 1133 Broadway, N. Y.

GLAZING POINT

H. A. Dreer, Philadelphia, Pa.
For page see List of Advertisers.
GLAZING POINTS, Lord & Burnham Special Glazing Nails (Points). Lord & Burnham, 1133 Broadway, N. Y.

GREENHOUSE BUILDING MATERIAL

Lord & Burnham Co., 1133 Broadway, New York.
For page see List of Advertisers.
Pierson U-Bar Co., 1 Madison Sq., N. Y.
For page see List of Advertisers.
A. T. Stearns Lumber Co., Neponset, Boston.
For page see List of Advertisers.
King Construction Co., N. Tonawanda, New York.
For page see List of Advertisers.
J. C. Montinger Co., 117 East Blackhawk St., Chicago, Ill.
For page see List of Advertisers.
Foley Mfg. Co., Western Ave., between 25th & 26th Sts., Chicago.
For page see List of Advertisers.

In writing to Advertisers kindly mention Horticulture

GREENHOUSE BUILDING MATERIAL - Continued

- I. Cassidy, Summer Ave. and Erie R. R., Newark, N. J.
For page see List of Advertisers.
- Geo. B. Doane, 18 Midway St., Boston, Iron Pipe.
For page see List of Advertisers.
- R. Jacobs & Sons, 1365-79 Flushing Ave., Brooklyn, N. Y.
For page see List of Advertisers.
- Wm. H. Lutton, West Side Avenue Sta., Jersey City, N. J.
For page see List of Advertisers.
- Metropolitan Material Co., 1398-1408 Metropolitan Ave., Brooklyn, N. Y.

GREENHOUSE CONSTRUCTION

- GREENHOUSE CONSTRUCTION, Semi-Iron Greenhouse, New Truss Houses and Iron Frame Houses, Lord & Burnham, 1133 Broadway, N. Y.**
- J. A. Payne, 260-274 Culver Ave., Jersey City, N. J.
For page see List of Advertisers.
- I. Cassidy, Summer Ave. and Erie R. R., Newark, N. J.
For page see List of Advertisers.
- Foley Mfg. Co., Western Ave., between 25th & 26th Sts., Chicago.
For page see List of Advertisers.
- Wm. H. Lutton, West Side Avenue Sta., Jersey City, N. J.
Curved Iceless Eave.
For page see List of Advertisers.
- The Weathered Co., New York City.
For page see List of Advertisers.

GUTTERS

- GUTTERS, Cast Iron Gutters, L. & B. Improved V Shaped Gutter with drip gutter attachment, Lord & Burnham, 1133 Broadway, N. Y.**

HAIL INSURANCE

- Florists' Hall Asso. of America.
J. G. Ester, Saddle River, N. J.
For page see List of Advertisers.

HARDY FERNS AND SUPPLIES

- H. M. Robinson & Co., 15 Province St. and 9 Chapman Pl., Boston, Mass.
For page see List of Advertisers.
- Michigan Cut Flower Exchange, 38 and 40 Broadway, Detroit, Mich. Fancy Ferns.
For page see List of Advertisers.

HEATING APPARATUS

- Lord & Burnham Co., 1133 Broadway, New York.
For page see List of Advertisers.
- Pierson U-Bar Co., 1 Madison Sq., N. Y.
For page see List of Advertisers.
- John A. Payne, 260-274 Culver Ave., Jersey City, N. J.
For page see List of Advertisers.
- Kroeschell Bros. Co., 35 Erie St., Chicago.
For page see List of Advertisers.

HELP FURNISHED

- Thos. H. Bambrick, 34 S. 7th St., Phila.
For page see List of Advertisers.

HERBACEOUS PERENNIALS

- Bay State Nurseries, No. Abington, Mass.
For page see List of Advertisers.
- P. Ouwerkerk, P. O. No. 2, Hoboken, N. J.
For page see List of Advertisers.

HOSE

- Henry A. Droege, 714 Chestnut St., Phila. Riverton Hose.
For page see List of Advertisers.

GREENHOUSE HOSE

- Mineralized Rubber Co., New York, N. Y.
Anchor grade wears well.

HOT-BED SASH

- The A. T. Stearns Lumber Co., Neponset, Mass.
For page see List of Advertisers.
- Pierson U-Bar Co., 1 Madison Sq., N. Y.
For page see List of Advertisers.
- Lord & Burnham Co., 1133 Broadway, N. Y.
For page see List of Advertisers.
- Foley Mfg. Co., Western Ave., between 25th & 26th Sts., Chicago.

HYDEANGEAS.

- F. R. Pierson Co., Tarrytown-on Hudson, N. Y.
Hydrangea Otaksa.
For page see List of Advertisers.
- John C. Hatcher, Amsterdam, N. Y.
For page see List of Advertisers.

INSECTICIDES.

- Nicotinide kills all greenhouse pests.
P. R. Paletherpe Co.,
Eleventh St., Owensboro, Ky.
For page see List of Advertisers.

JAPANESE PLANTS

- Yokohama Nursery Co., 31 Barclay St., New York.
For page see List of Advertisers.

JUMPING BEANS

- Jumping Beans, \$5 per 1000, post paid.
McDowell, Mexico City.

KENTIAS

- Godfrey Aschmann,
1012 W. Ontario St., Phila., Pa.
For page see List of Advertisers.
 - A. Leuthy & Co., Rosindale, Mass.
For page see List of Advertisers.
 - Jos. Heacock Co., Wyncote, Pa.
For page see List of Advertisers.
- | | Each | Doz. |
|---------------------------|-------|----------------|
| Kentia Belmoreana, 6-in. | | \$1.50 \$18.00 |
| " 7-in. | | 1.75 21.00 |
| " 8-in. | | 2.50 30.00 |
| " 8-in. strong. | 1.00 | 48.00 |
| " 9-in. | | 6.00 |
| Kentia Forsteriana, 7-in. | | 2.50 30.00 |
| " 8-in. | | 3.00 36.00 |
| " 8-in. strong. | 5.00 | 60.00 |
| " 9-in. | | 6.00 72.00 |
- Made-up Kentia Forsteriana, 6.00 72.00
Wirthhold Co., 1657 Buckingham Place,
Chicago, Ill.

LILIES (Cut Blooms)

- Lilies, large, pure white, fragrant, 10 cents per bud and bloom, large or small lots. E. M. Ingalls, Florist, 13 Whiting St., Lynn, Mass. Tel. 5073.

LOBELIAS

- Double Lobelia, Kathleen Mallard, 2 1/2 in., 4c. Strong cuttings from soil, all full of buds and bloom. J. L. Stone, Trumansburg, N. Y.

MASTICA

- F. O. Pierce Co., 12 W. Broadway, New York.
For page see List of Advertisers.

MOON VINES

- Godfrey Aschmann, 1012 W. Ontario St., Philadelphia.
For page see List of Advertisers.

MYRTLE

- Myrtle for cemetery planting, strong field grown clumps, \$2.00 per 100, or \$17.50 per 1000. Geo. A. Dhanau, East Walnut Hills, Cincinnati, O.

NEW AND RARE PLANTS

- Rose Hill Nurseries, New Rochelle, N. Y.
For page see List of Advertisers.

NICO-FUME

- Kentucky Tobacco Product Co., Louisville, Ky.

NURSERY STOCK

- John Waterer & Sons, Ltd., American Nursery, Bagshot, England.
For page see List of Advertisers.
- Ray State Nurseries, N. Abington, Mass.
- Herbaceous Perennials, Hardy Ornamental Trees.
For page see List of Advertisers.
- Cleary's Horticultural Co., 62 Vesey St., New York.
For page see List of Advertisers.
- P. Ouwerkerk, 216 Jane St., Weehawken Heights, N. J.
- Holland Nursery Stock for Forcing.
For page see List of Advertisers.
- American Nursery Co., 150 Broadway, New York, N. Y.
For page see List of Advertisers.

ORCHID PLANTS

- Lager & Hurrell, Summit, N. J.
For page see List of Advertisers.
- Sander, St. Albans, England.
Importers, Exporters, Growers, Hybridists
For page see List of Advertisers.
- Julius Roehrs Co., Rutherford, N. J.
For page see List of Advertisers.
- Carrillo & Baldwin, Secaucus, N. J.
For page see List of Advertisers.
- Jos. A. Manda, 191 Valley Road, W. Orange, N. J.
For page see List of Advertisers.
- Ordonez Bros., Madison, N. J., Box 105.
For page see List of Advertisers.
- Largest stock in the country. Ask for prices. Julius Roehrs, Rutherford, N. J.

PALMS

- A. Leuthy & Co., Perkins St. Nurseries, Rosindale, Mass.
For page see List of Advertisers.
- Robert Craig Co., Market and 49th Sts., Philadelphia, Pa.
For page see List of Advertisers.
- August Rolker & Sons, 31 Barclay St., New York.
For page see List of Advertisers.
- Joseph Heacock Co., Wyncote, Pa. Home-Grown Palms.
For page see List of Advertisers.

PAINT AND PUTTY

- PAINT AND PUTTY: Ideal Greenhouse lead; Special Greenhouse Putty. Lord & Burnham, 1133 Broadway, N. Y.**

PATENTS

- Siggers & Siggers, Washington, D. C.
For page see List of Advertisers.

PEAT

- Orchid peat, Rotted peat, Azalea peat, Leaf-Mould, Live Sphagnum moss, Baled Sphagnum moss, Green Clump moss, etc. Jobbers' list on application. C. W. Brownell & Co., Walden, N. Y.

PEONIES

- The E. G. Hill Co., Richmond, Ind. 1-Year Transplanted Peony Clumps.
For page see List of Advertisers.
- Wholesale Peony list for fall 1908 is now ready. J. F. Rosefield, West Point, Neb.
- One of the finest collections in America. Send 25 cts. in stamps for new edition of Peony Manual. C. S. Harrison's Select Nursery, York, Neb.

PETUNIAS

- Star Petunias from 2-in. pots, fine, clean plants, \$2.00 per 100, \$18.00 per 1000. W. E. Hall, Clyde, O.
- Petunia Rosy Morn, the best bidder, in bud and bloom, 2 1/2 in., ready for shift, \$2.00; 3-in., \$3.00 per 100. Reginald Pratt, Wayne, Pa.

PHLOXES

- Send 25 cts. in stamps for Phlox Manual. Fine mixed phloxes \$1.50 per 100. C. S. Harrison's Select Nursery, York, Neb.

PIPE AND FITTINGS

- Foley Mfg. Co., between Western Ave. and 26th St., Chicago, Ill.
For page see List of Advertisers.
- Kroeschell Bros. Co., 35 Erie St., Chicago.
For page see List of Advertisers.

- PIPE AND FITTINGS. Cast Iron and Wrought Pipe, Valves, Elbows, Pipe Hooks, Automatic Air Headers, etc. Lord & Burnham, 1133 Broadway, N. Y.**

PLANT BED CLOTH

- Protects your plants.
Mineralized Rubber Co., New York, N. Y.

PLANT TUBS

- H. A. Droege, 714 Chestnut St., Phila.

For List of Advertisers See Page 869

POT HANGERS

Pot hangers, Kramer's \$1 doz. by exp. \$1.25 by mail. I. N. Kramer & Son, Cedar Rapids, Ia.

RAFFIA

Raffia (colored), 20 beautiful shades. Samples free. R. H. Comey Co., Camden, N. J.; 810 Washburn Ave., Chicago, Ill.

RETAIL FLORISTS

Park Floral Co., Denver, Colo.
For page see List of Advertisers.

Gude Bros. Co., 1214 F St., Washington, D. C.
For page see List of Advertisers.

Atlanta Floral Co., Atlanta, Ga.
For page see List of Advertisers.

M. C. & J. E. Hauswirth, 232 Michigan Ave., Chicago.
For page see List of Advertisers.

William J. Smyth, Michigan Ave. and 31st St., Chicago.
For page see List of Advertisers.

George Wittbold Co., 1657-59 Buckingham Place, Chicago.
For page see List of Advertisers.

Jacob Schnitz, 644 4th Ave., Louisville, Ky.
For page see List of Advertisers.

Thos. F. Galvin, 124 Tremont St., Boston.
For page see List of Advertisers.

Julius A. Zinn, 2 Beacon St., Boston.
For page see List of Advertisers.

Houghton & Clark, 396 Boylston St., Boston.
For page see List of Advertisers.

Sidney Hoffman, 59-61 Massachusetts Ave., Boston.
For page see List of Advertisers.

Edward MacMulkin, 194 Boylston St., Boston.
For page see List of Advertisers.

J. Breitmeyer's Sons, Detroit, Mich.
For page see List of Advertisers.

Samuel Murray, 1017 Broadway, Kansas City, Mo.
For page see List of Advertisers.

Wm. L. Rock Flower Co., 1116 Walnut St., Kansas City, Mo.
For page see List of Advertisers.

Fred C. Weber, 4326 Olive St., St. Louis, Mo.
For page see List of Advertisers.

J. N. Champlon & Co., 1026 Chapel St., New Haven, Conn.
For page see List of Advertisers.

H. G. Eyres, 11 N. Pearl St., Albany, N. Y.
For page see List of Advertisers.

David Clarke's Sons, 2139-2141 Broadway, New York.
For page see List of Advertisers.

Alex. McConnell, New York.
For page see List of Advertisers.

Robert G. Wilson, Fulton St. and Greene Ave., Brooklyn, N. Y.
For page see List of Advertisers.

Yong & Nugent, 42 W. 28th St., N. Y.
For page see List of Advertisers.

J. H. Dunlop, 96 Yonge St., Toronto, Can.
For page see List of Advertisers.

RHODODENDRONS

John Waterer & Sons, Ltd., American Nursery, Bagshot, England.
For page see List of Advertisers.

P. Ouwerkerk, Hoboken, N. J.
For page see List of Advertisers.

Eastern Nurseries, Jamaica Plain, Mass.
Hardy Hybrid and Dwarf Rhododendrons.
For page see List of Advertisers.

ROSES

Bay State Nurseries, N. Abington, Mass.
For page see List of Advertisers.

Robert Craig Co., Market and 49th Sts., Philadelphia, Pa.
For page see List of Advertisers.

Dingee-Conard Co., West Grove, Pa.
For page see List of Advertisers.

R. & J. Farquhar & Co., 6 and 7 South Market Street, Boston.
For page see List of Advertisers.

Poehlmann Bros. Co., Morton Grove, Ill.
Mrs. Potter Palmer, Cardinal, Beauty.
For page see List of Advertisers.

ROSES — Continued

P. R. Quinlan, Syracuse, N. Y.
Killarney, Richmond, Bridesmaids.
For page see List of Advertisers.

Leo Niessen Co., 1269 Arch St., Phila., Pa.
Rose Plants Ready.

P. Ouwerkerk, P. O. No. 2, Hoboken, N. J.
For page see List of Advertisers.

John C. Hatcher, Amsterdam, N. Y.
For page see List of Advertisers.

Low-budded roses, No. 1, \$95.00; No. 1 1-2, \$65.00 1000. H. T. Jones, Elizabeth, N. J.

S. A. F. CONVENTION ACCOMMODATIONS

Tower Hotel, Niagara Falls, N. Y.
For page see List of Advertisers.

SEEDS

T. J. Grey Co., 32 So. Market St., Boston, Mass.
For page see List of Advertisers.

Joseph Breck & Sons, 51 and 52 N. Market St., Boston, Mass.
For page see List of Advertisers.

W. Atlee Burpee & Co., Philadelphia.
For page see List of Advertisers.

J. M. Thorburn & Co., 33 Barclay St., N. Y.
For page see List of Advertisers.

Arthur T. Boddington, 342 W. 14th St., New York.
Boddington's Challenge Pansy, also Sweet Peas for Thanksgiving and Christmas.
For page see List of Advertisers.

H. F. Michell Co., 1017 Market St., Phila.
For page see List of Advertisers.

James Vick's Sons, Rochester, N. Y.
Vick's Superb Pansy Seed.
For page see List of Advertisers.

Hjalmar Hartmaon & Co., 12 Stormgade, Copenhagen, Denmark.
Cauliflower and Cabbage Seed.
For page see List of Advertisers.

Rickards Bros., 37 E. 19th St., New York.
For page see List of Advertisers.

R. & J. Farquhar & Co., 6-7 So. Market St., Boston.
For page see List of Advertisers.

Braslan Seed Growers Co., San Jose Cal.
For page see List of Advertisers.

H. E. Fiske Seed Co., Faneuil Hall Sq., Boston.
For page see List of Advertisers.

O. V. Zaagen, Hoboken, N. J.
For page see List of Advertisers.

John F. Rupp, Shiremanstown, Pa.
Chinese Primrose, Cineraria, Giant Pansy Seeds.
For page see List of Advertisers.

SMILAX

R. Vincent, Jr. & Sons Co., White Marsh, Md.
For page see List of Advertisers.

Smilax, choice young plants from fall; \$3.00 per 1000, 2000 for \$5.00, 5000 for \$10.00; 50c. per 100 by mail. F. A. Baller, Bloomington, Ill.

Smilax, strong, 2 1/4 in. pots, \$1.75 per 100; \$15.00 per 1000. Seedlings, 25 cents per 100; \$2.00 per 1000. Wm. Livesey, McCabe St., New Bedford, Mass.

SPHAGNUM MOSS

Live Sphagnum moss, orchid peat and orchid baskets always on hand. Lager & Hurrell, Summit, N. J.

SPRAYERS

Charles J. Jager Co., 281-85 Franklin St., Boston.

"SHOWERMAKER," \$1. Jos Kopesay, So. Bend, Ind.

STEAM TRAP

E. Hippard, Youngstown, O.

SWEET PEAS

A. C. Zvolanek, Round Brook, N. J.
Winter Flowering.
For page see List of Advertisers.

TO-BAK-INE

E. H. Hunt, Genl. Agt., 76-78 Wabash Av., Chicago.
For page see List of Advertisers.

TUBEROSES

Stump & Walter Co., 50 Barclay St., New York.
For page see List of Advertisers.

No. 1 Pearl Tuberose bulbs, \$5.00 per 100. Schlegel & Fottler Co., 26 South Market St., Boston.

VEGETABLE PLANTS

R. Vincent, Jr. & Sons Co., White Marsh, Maryland.
For page see List of Advertisers.

VENTILATING APPARATUS

Pierson U-Bar Co., 1 Madison Sq., N. Y.
For page see List of Advertisers.

Foley Mfg. Co., Western Ave., between 25th & 26th Sts., Chicago.
For page see List of Advertisers.

John A. Payne, 260-274 Culver Ave., Jersey City, N. J.
For page see List of Advertisers.

The Advance Co., Richmond, Ind.
For page see List of Advertisers.

Quaker City Machine Co., Richmond, Ind.
20th Century Ventilating Arm.
For page see List of Advertisers.

VENTILATING MACHINERY, New Model enclosed, self-oiling gear; Standard Model Open Gear. Lord & Burnham, 1132 Broadway, N. Y.

VIOLETS.

Lady Campbell violets, 25,000 extra fine, sand-rooted cuttings, \$1.00 per 100, by mail; \$7.00 per 1000, by express; 500 at 1000 rate. Satisfaction guaranteed. Field-grown plants of Campbell and California ready in August. Chas. Black, Hightstown, N. J.

Maria Louise and Farquhar violet plants, strong, February and March sand struck, clean and free from disease, \$2.00 per 100; \$15.00 per 1000. Will be ready May 15. Cash with order, please. C. Lawrtzen, Box 261 Rhinebeck, N. Y.

How to Make Money Growing Violets, will be sent postpaid for 25c., by Horticulture Publishing Co., 11 Hamilton Place, Boston.

Commercial Violet Culture, by B. T. Galloyay, sent postpaid for \$1.50, by Horticulture Publishing Co., 11 Hamilton Place, Boston.

Violet Marie Louise, No. 1 sand rooted cuttings for sale. Write for prices. Alva Bishop, P. O. Box 163, Rhinebeck, N. Y.

VINCAS

John C. Hatcher, Amsterdam, N. Y.
For page see List of Advertisers.

WIRED TOOTHPICKS

W. J. Cowee, Berlin, N. Y.
For page see List of Advertisers.

WIREWORK

Reed & Keller, 122 W. 25th St., N. Y.
For page see List of Advertisers.

Weigel & Ujfalussy, 136-138 W. 28th St., New York.
Florists' Wire Designs and Supplies.
For page see List of Advertisers.

Wirework. Write for our catalogue. Holton & Hunkel Co., Milwaukee, Wis.

William E. Hellscher's Wire Works, 38-40 Broadway, Detroit, Mich.

Headquarters for wire work. Send for list Ball & Betz, 31 E. 3rd St., Cincinnati, O.

In writing to Advertisers kindly mention Horticulture

WHOLESALE FLORISTS**Boston**

N. F. McCarthy & Co., 84 Hawley St., Boston.
For page see List of Advertisers.

H. M. Robinson & Co., 15 Province St. and 9 Chapman Pl., Boston.
For page see List of Advertisers.

Welch Bros., 226 Devonshire St., Boston.
For page see List of Advertisers.

Buffalo

Wm. F. Kasting Co., 383-87 Ellcott St., Buffalo, N. Y.
For page see List of Advertisers.

Chicago

Chas. W. McKellar, 51 Wabash Ave., Chicago.
For page see List of Advertisers.

Peter Reinberg, 51 Wabash Ave., Chicago.
For page see List of Advertisers.

E. F. Winterson Co., 45-49 Wabash Ave., Chicago.
For page see List of Advertisers.

J. A. Budlong, 37-39 Randolph St., Chicago.
For page see List of Advertisers.

Detroit

Michigan Cut Flower Exchange, 38 and 40 Broadway, Detroit, Mich.
For page see List of Advertisers.

Minneapolis

Rice Bros., 115 N. 6th St., Minneapolis, Minn.
For page see List of Advertisers.

New York

J. K. Allen, 106 W. 28th St., New York
J. S. Fenrich, 110 W. 28th St., New York
For page see List of Advertisers.

Ford Bros., 48 W. 28th St., New York
For page see List of Advertisers.

H. E. Froment, 57 W. 28th St., New York
For page see List of Advertisers.

Alex. J. Guttman, 34 W. 28th St., New York.
For page see List of Advertisers.

E. C. Horan, 55 W. 28th St., New York
For page see List of Advertisers.

A. H. Langjahr, 55 W. 28th St., New York
For page see List of Advertisers.

James McManus, 42 W. 28th St., New York
For page see List of Advertisers.

John I. Raynor, 49 W. 28th St., New York
For page see List of Advertisers.

W. F. Sheridan, 39 W. 28th St., New York
For page see List of Advertisers.

Traendly & Schenck, 44 W. 28th St., New York.
For page see List of Advertisers.

Moore, Hentz & Nash, 55 and 57 W. 26th St., New York.
For page see List of Advertisers.

Frank S. Hicks & Co., 39 W. 28th St., New York.
For page see List of Advertisers.

Wm. H. Kuebler, 28 Willoughby St., Brooklyn, N. Y.
For page see List of Advertisers.

Phillip F. Kessler, 55 and 57 W. 28th St., New York.
For page see List of Advertisers.

A. Moltz, 55-57 W. 26th St., New York.
For page see List of Advertisers.

Millang Bros., 41 W. 28th St., New York.
For page see List of Advertisers.

Philadelphia

W. E. McKisslek, 1619-1621 Ranstead St., Philadelphia, Pa.
For page see List of Advertisers.

Leo Niessen Co., 1209 Arch St., Philadelphia, Pa.
For page see List of Advertisers.

The S. S. Pennock-Meehan Co., 1608-16 Ludlow St., Philadelphia, Pa.
For page see List of Advertisers.

Philadelphia—Continued.

Edward Reld, 1526 Ranstead St., Philadelphia, Pa.
For page see List of Advertisers.

Pittsburg

J. B. Murdoch & Co., 714 Penn Ave., Pittsburg, Pa.
For page see List of Advertisers.

St. Louis

H. G. Berning, 1402 Pine St., St. Louis, Mo.
For page see List of Advertisers.

WHOLESALE PLANTSMAN

Sammel A. Woodrow, 53 W. 30th St., New York.
For page see List of Advertisers.

WILD SMILAX

E. A. Beaven, Evergreen, Ala.
Southern Wild Smilax: Log Mossee.
For page see List of Advertisers.

New Offers in This Issue.**ASPARAGUS, KENTIAS, FERNS, ETC.**

M. H. Rose, 16 Macomb St., Detroit, Mich.
For page see List of Advertisers.

FERNS IN FLATS.

E. Leuty, 528 Summit Av., W. Hoboken, N. J.
For page see List of Advertisers.

LILIUM HARRISII.

E. R. Pierson Co., Tarrytown-on Hudson, N. Y.
For page see List of Advertisers.

PANSY SEEDS.

H. E. Fiske Seed Co., 12 Faneuil Hall Sq., Boston.
For page see List of Advertisers.

ROSE'S EUREKA FOR SCALE, ETC.

M. H. Rose, 16 Macomb St., Detroit, Mich.
For page see List of Advertisers.

ROSES OWN ROOTS: GERANIUMS.

S. J. Reuter & Son, Westerly, R. I.
For page see List of Advertisers.

RUBBER HOSE.

H. V. Mitchell Co., Philadelphia.
For page see List of Advertisers.

STOKES' STANDARD PANSY SEED;**FRENCH AND DUTCH BULBS.**

Walter P. Stokes, 219 Market St., Phila.
For page see List of Advertisers.

LIST OF PATENTS.

886,122 Cultivator, Charles S. Sharp, Auburn, N. Y., assignor to International Harvester Company, a corporation of New Jersey.

886,525 Machine for Catching Boll-Weevil, William M. McCurdy and Robert J. McCurdy, Couchhatta, La.

886,555 Fruit and Flower Picker, Jonathan B. Tuttle, Claremont, Cal.

886,711 Rake-Cleaner, James E. Lucas, Broadland, Ill., assignor of one-half to Harley Berman, Sidell, Ill.

886,979 Weeder and Cultivator, Ormiston J. Gonzalez, Palms, Cal.

887,596 Hoing Cultivator, Jesse W. Davis, Middleton, Tenn.

887,653 Plant Support, George L. Kline, Warren, Pa.

889,419 Support for Lawn-Hose, Lawrence E. Whitney, Carthage, Mo.

WANTS, FOR SALE, ETC.

Advertisements in this column one cent a word. Initials count as words. Cash with order. All correspondence addressed "care HORTICULTURE" should be sent to 11 Hamilton Place, Boston.

SITUATIONS WANTED**GOOD MEN**

When you need good men, skilled or unskilled, Write:

THOS. H. BAMBRICK

34 South 7th Street Philadelphia

Help of all kinds, including that for Florists, Nurserymen, Seedsmen and the Horticultural trade generally.

HELP WANTED

A GOOD side line for salesmen calling on greenhouses, etc. Pocket samples. State territory and references. Factory, P. O. Box 1371, New York.

FOR SALE

FOR SALE—Greenhouses. About 30,000 feet of glass in first-class condition, well stocked with roses; fine location for retail trade. Handy to Boston market for wholesale; chance of a life time. Reason for selling; all my time is taken up with other business. Write for particulars or call and see them. Address H. F. Crawford, Montello Station, Brockton, Mass.

FOR SALE—Special—Glass for sale below cost. 16 x 24 double thick American A. & B. qualities, below cost, for immediate acceptance. Never such an opportunity offered before. Write Parshelsky Bros., 59 Montrose Ave., Brooklyn, N. Y.

FOR SALE—27,000 feet of glass; filled with first-class stock; located in one of Chicago's suburbs; low price. Address Florist, 4016 N. Clark St., Chicago.

FOR SALE: In Providence, R. I., a first-class Florist store, well stocked and doing a good business; on the main street; 8 years established; a bargain if taken at once. J. S. Kelly, 81 Jenkins St., Providence, R. I.

889,488. Stump and Tree Puller. Stephen M. Smith, Boise, Idaho.

889,947. Seed Planting Machine. Horace H. Miller, Lyndon, Vt.

890,051. Potato-Bagging Machine. Martin Harmon, Bloomington, Ill.

890,074. Rake. Samuel P. Lerch, Canton, Ohio.

890,209. Hay-Rake and Loader. Chas. W. Baird, Deep River, Ia.

890,279. Apparatus for Cutting the Edges of Lawns and the like. John Hoare Belfast, New Zealand.

890,378. Cultivator. Alfred G. Schunzel, Pittsburg, Pa.

890,495. Potato-Bug Exterminator. Benjamin Carlson and Casper Carlson, Onokama, Mich.

890,991. Hoe. William F. Marsh, Malaga, N. J.

890,998. Lawn-Mower. Elwood W. McGuire, Richmond, Ind.

891,079. Carnation Supporter. William Greer, Great River, N. Y.

891,096. Pea-Separator. William S. Pope, Sneads, Fla.

List of Advertisers

Page	Page
Advance, The Co. 871	Manda Jos. A. 855
Altimo Culture Co. 857	MacMullin E. A. 859
American Nursery 844	McCarthy N. F. & Co. 863
American Nursery Co. 844	McConnell Alex. 858
Aschmann G. 843	McKellar Charles W. 860
Atlanta Floral Co. 858	McKissick, W. E. 860
Bambrick Thos. H. 861	McManus Jas. 862
Barrows H. H. & Son. 855	Michell H. F. Co. 857-869
Bayersdorfer H. & Co. 859	Michigan Cut Flower Exchange. 863
Bay State Nurseries. 844	Millaog Bros. 863
Beaven E. A. 860	Mitting, A. 842
Berning H. G. 863	Moltz, A. 863
Boddington A. T. 842-857	Moninger J. C. 870
Boston Florist Letter Co. 863	Moore, Heutz & Nash. 862
Boston Plate and Window Glass Co. 869	Murdoch J. B. & Co. 860
Bosch, Felix. 843	Murray Samuel 858
Bostrom-Brady Mfg. Co. 861	Niessen Leo. Co. 860
Braslan Seed Growers Co. 857	Oechslin Frank. 855
Breck Joseph & Sons. 857	Ordonez Bros. 855
Breitmeier's J. Sons. 858	Ouwwerker P. 844
Bridgeman's Seed Warehouse. 857	Palethorpe P. R. Co. 869
Budloog J. A. 860	Park Floral Co. 858
Burpee W. A. & Co. 857	Payoe John A. 869
Carrillo & Baldwin 855	Pennoek-Meehan Co. 861
Cassidy I. 871	Perkins St. Nurseries. 842
Castle Co. 870	Pierce F. O. Co. 871
Champion J. N. & Co. 858	Pierson, A. N. 842
Chicago Carotation Co. 843	Pierson F. R. Co. 843-855
Clarke's David, Sons. 858	Pierson U Bar Co. 872
Cleary's Horticultural Co. 863	Poehlmann Bros. Co. 844
Cowee W. J. 859	Pulverized Manure Co. 869
Craig, Robt. Co. 844	Quaker City Machine Co. 871
Dingee & Conard Co. 844	Quinlan P. R. 844
Doane Geo. B. & Son. 871	Raynor John I. 862
Dorner F. Sons & Co. 843	Reed & Keller. 862
Dreer H. A. 869-871	Reid Edw. 850
Dunlop John H. 858	Reinberg Peter. 860
Dysart R. J. 860	Reuter S. J. 844-855
Eastero Nurseries. 844	Rice Bros. 860
Edwards Folding Box Co. 860	Rickards Bros. 857
Elliott Wm & Sons 869	Robinson H. M. & Co. 861
Esler J. G. 871	Rock Wm. L. Flo. Co. 858
Ernest W. H. 870	Roehrs Julius Co. 855
Eskesen Frank K. 855	Rohr Albert. 843
Eyres. 858	Roland, Thomas 842
Farquhar R. & J. Co. 844	Rolker August & Sons 842-870
Fenrich J. S. 862	Rose Hill Nurseries. 842
Fiske, H. E. Seed Co. 857-869	Rose M. F. 843-879
Foley Mfg. Co. 871	Rupp J. F. 857
Ford Bros. 862	Sander & Son. 855
Froment H. E. 862	Schlur ff Vera L. 842
Galvin Thos. F. 859	Schulz Jacob. 858
Grey T. J. Co. 857	Scott, John. 855
Gude Bros. Co. 858	Sharp, Partridge & Co. 870
Gutman Alex. J. 862	Sheridan W. F. 862
Haerens A. 842	Siggers & Siggers. 869
Hall Asso. 871	Situations & Wants. 860
Haines, J. E. 843	Skidelskv S. S. 842
Hartmann Hjalmar & Co. 857	Smyth Wm J. 858
Hatcher, John C. 843	Standard Plate Glass Co. 870
Hauswirth M. C. & J. E. 858	Stearns A. T. Lumber Co. 841
Heacock Joseph. 844	Stokes Seed Co. 856
Herbert David & Son. 842	Stump & Walter Co. 842-869
Hews A. H. & Co. 870	Thorburn J. M. & Co. 857
Hicks Frank S. & Co. 863	Totty Chas. H. 855
Hilfinger Bros. 870	Tower Hotel. 860
Hill, The E. G. Co. 844	Traendly & Schenck. 862
Hoenig M. J. 860	Valentioe, J. A. 858
Hoffman. 859	Velthuis K. 843
Houghton & Clark. 857	Vick's Jas. Sons 857
Hunt E. H. 869	Vincent R. Jr. & Sons. 842-856
Jacobs S. & Sons. 870	Waterer John & Sons. 844
Kasting W. F. 863	Weathered Co. 872
Kessler, P. F. 862	Weber F. C. 858
Klog Coos. Co. 871	Welch Bros. 860
Kroeshill Bros. 870	Weigel & Ujfalussy. 859
Kuebler Wm H. 863	Wilson. 868
Lager & Hurrell 855	Winterson, E. F. Co. 860
Langjahr, Alfred H. 862	Wittbold Geo. Co. 858
Leuly E. 855	Woodrow, Sam'l A. 863
Leuthy A. & Co. 842	Yokohama Nursery Co. 843
Lord & Burnham Co. 872	Young & Nugent. 858
Lutton W. H. 871	Zaugen O. V. 87
	Zinn Julius A. 859
	Zovlanek A. C. 857

JOHN A. PAYNE

Greenhouse Designer and Builder

260-274 Culver Ave., Jersey City



THE PAYNE

Galvanized Iron non-freezing Z Bar Eaves Plate is acknowledged to be the best and the most durable. No inside drip, no sockets to hold moisture around wood bars.

Iron and wood frame greenhouses of every type—material only or erected. LET US ESTIMATE.

PATENTS

Trademarks and Copyrights

Send your business direct to Washington. Saves time and insures better service. Personal attention guaranteed. Twenty-five years' active service. SPECIALTY: "Working on the Failure of Others."

SIGGERS & SIGGERS

PATENT LAWYERS

Box 9, National Union Building Washington, D. C.



DREER'S

FLORIST SPECIALTIES.

New Brand "New Style" Hose "REVERTON"

Furnished in lengths up to 500 ft. without seam or joint.

The HOSE for the FLORIST

3/4-inch, per ft., 15 c.

Reel of 500 ft., 14 1/2 c.

2 Reels, 1000 ft., 14 c.

1 1/2-inch, 13 c.

Reels, 500 ft., 12 1/2 c.

Couplings furnished.

HENRY A. DREER,

714 Chestnut St., PHILADELPHIA, PA.

GREENHOUSES BUILDING OR CONTEMPLATED.

Newport, R. I.—Mrs. F. O. French. Leonton, O.—H. G. Wolfgang, house 20x50.

Boothwyn, Pa.—John Frigar, conservatory.

Ft. Dodge, Ia.—Otto Hanson, range of houses.

Salina, Kan.—Edward Tatro, range of houses.

Mt. Greenwood, Ill.—W. N. Rudd, house 38x125.

E. Palestine, O.—J. N. Spanabel, range of houses.

Milwaukee, Wis.—W. Edlefson, two houses, each 25x150.

Washington, D. C.—Gude Bros., five 16se houses, each 40x200; palm house, 60x160.

DON'T EXPERIMENT USE **To-BAK-INE** and your stock will be free from insects, clean, and the blooms will not be discolored.

Send for full information of

H. E. FISKE SEED CO. 13 Faneuil Hall Sq., Boston, Mass.

STUMPP & WALTER CO., 50 Barclay St., New York.

HENRY F. MICHELL & CO., 1018 Market St., Philadelphia.

E. H. HUNT, Gen'l Agent, 76-78 Wabash Ave., Chicago.

The Best Bug Killer and Bloom Saver

For PROOF Write to

P. R. Palethorpe Co. OWENSBORO, KY.

IF YOU ARE TROUBLED with Scale, Thrip, Red Spider, Black and Green Fly, Mildew, Rust, Stem Rot, etc., ... USE ...

ROSE'S EUREKA the never failing remedy. \$1.00 per Bottle, \$9.00 per dozen Bottles.

M. H. ROSE, 46 Macomb Street, DETROIT, MICH. Agents Wanted in Every State.

STERILIZED Sheep Manure to help out backward vegetation, 100 lbs. \$1.50.

W.M. ELLIOTT & SONS 42 Vesey Street, New York

Cattle Manure In Bags Shredded or Pulverized

Best and safest manure for florists and greenhouse use, absolutely pure, no waste, no danger. Write for circulars and prices.

The Pulverized Manure Co., 31 Union Stock Yards, Chicago

BOSTON PLATE & WINDOW GLASS CO. GREENHOUSE GLASS German and American 261 to 287 A St., Boston 20-22 Canal St.

?
Is Your Name In The Above List? If Not, Why Not?
?

GREENHOUSE HEATING

From The Weekly Florists' Review, Dec. 20, 1906.

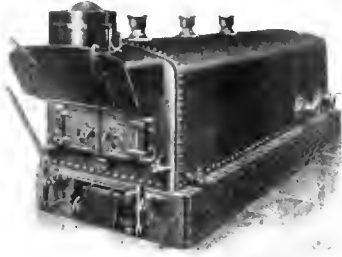

A HEATING RECORD

I have two houses, each 23 x 100, in which I grow lettuce and general stock. I keep a night temperature 50 to 52 degrees. They are heated with hot water. I had a special boiler made to order that has proved itself beyond my expectations. In the winter of 1905-6 I used thirty-one tons of coal at \$1.90 and ten cords of 3 foot wood worth about \$2.50 per cord. This I thought very reasonable. The circulation is perfect. Last winter in moderate weather, that is, not windy and outside temperature 20 degrees or so above zero, I would leave the boiler nine hours with a variation of but 3 degrees.

Ten days ago I was called to Cleveland over night. The outside temperature was 40 degrees at 2.45 p. m., when I left the boiler, with a gradually sinking mercury. There being no men about, I left instructions that the boiler should not be touched until next morning. My wife, on my return next evening, reported that at 7 p. m. it became quite windy and by 9.30 was freezing, with stormy outlook. When she awoke at 6 a. m., the outside temperature was 20 degrees, and the greenhouses were 47 degrees. I think this is a record for **fifteen hours and twenty minutes without attention.** I would like to hear from anyone who can beat it.

C. S. TEMPLEN, Garrettsville, Ohio.

THIS IS A KROESCHELL BOILER, ASK HIM.

KROESCHELL BROS. CO., 35 ERIE ST., CHICAGO

Don't Build

without first investigating the best device ever invented for *Heating Economy.*

Don't Repair

until you have got some information as to how we can help you by installing the

ELECTRIC CIRCULATOR

State your proposition and we will reply promptly. It will cost you nothing but a two cent stamp.

THE CASTLE COMPANY, HEATING ENGINEERS
170 Summer Street, - BOSTON, MASS.



STANDARD FLOWER POTS

Packed in small crates, easy to handle.

Price per crate		Price per crate	
1500 7 in. pots in crate	\$4.88	120 7 in. pots in crate	\$4.20
1500 3 1/2 " " "	5.25	60 8 " " "	3.00
1500 2 3/4 " " "	6.00	HAND MADE	
1000 3 " " "	5.00	48 9 in. pots in crate	\$3.60
800 3 1/2 " " "	5.80	48 10 " " "	4.80
500 4 " " "	4.50	24 11 " " "	3.60
320 5 " " "	4.51	24 12 " " "	4.80
144 6 " " "	3.16	12 14 " " "	4.80
		6 16 " " "	4.50

Seed pans, same price as pots. Send for price list of Cylinders for Cut flowers, Hanging Baskets, Lawn Vases, etc. Ten percent. off for cash with order. Address Hillinger Bros., Pottery, Fort Edward, N. Y. August Rolker & Sons, Agts., 31 Barclay St., N. Y. City.

Standard Flower . . . POTS

If your greenhouses are within 500 miles of the Capitol, write us, we can save you money

W. H. ERNEST

28th and M Street WASHINGTON D. C.

STANDARD PLATE GLASS CO.

Manufacturers—Importers—Jobbers

NOW IS THE TIME TO BUY

FRENCH OR AMERICAN GREENHOUSE GLASS

LOWEST PRICES ON REQUEST

26-30 Sudbury St. BOSTON, MASS. 61-63 Portland St.

GLASS

Always Write Us Before Buying

SHARP, PARTRIDGE & CO.

22nd and Lumber Streets, CHICAGO

WE HAVE SOME SNAPS

OTHER BUSINESS MEN

MAY "EASE UP"

during the heated term but the florist does not. His greenhouses must be repaired and it takes Glass and Pipes and Lumber to do it.

Now is the time to advertise if you want his trade

His Boiler must be made right now; if you sell heating apparatus get him to buy a new one. Peiha's time has come for a new watering system. You can reach him most effectively through an advertisement in these pages, **JUST NOW.**

S. JACOBS & SONS

Manufacturers of GULF CYPRESS

GREENHOUSE MATERIAL

HOT-BED-SASH & FRAMES

Jobbers in Boilers-Pipe-Fittings and

GLASS on which we can quote attractive prices. Disc on large quantities.

We furnish everything for Greenhouse Building

1365-1379 Flushing Avenue

BROOKLYN, - NEW YORK

GREENHOUSE CONSTRUCTION

LUMBER

John C. Moninger Co.

117 E. Blackhawk St., CHICAGO

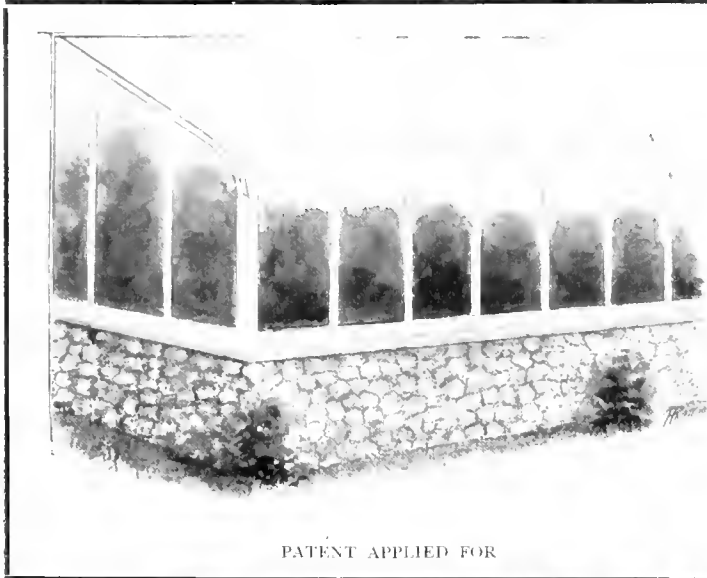

Why My New Curved Iceless Eave is Far Superior to Anything on the Market Today

- 1st. No sash bars incased in iron, thereby eliminating all danger of bars decaying.
- 2nd. Can be used in conjunction with iron frame construction, thereby doing away with that very objectionable feature, "columns."
- 3rd. Roof bars with drip grooves, which act as conductors to carry away the condensation: **Result**, the driest roof ever used for greenhouse purposes.
- 4th. **THE MOST IMPORTANT OF THEM ALL.** The very small increase in cost over the ordinary style of construction which makes it possible to be used for commercial as well as private purposes.

William H. Lutton, Horticultural Architect and Builder
West Side Ave Station (C.R.R. of N.J.) Jersey City, N.J.

PATENT APPLIED FOR

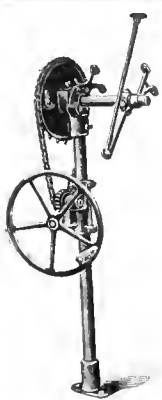

The Advance Ventilating Apparatus

"Your machine is the best we have ever used" is what an Ohio florist writes us in remitting for his machine. It is not good only in one part but it is the best in all parts—the results of experience, of careful study, of mechanical construction, best material and backed by moderate prices that makes our line so popular. Give us a trial.

The Advance Co.
RICHMOND, IND.

IRON PIPE

SECOND HAND

WROUGHT IRON PIPE, for Steam, Water, Gas or Oil, Fences or Posts. All Sizes. Price Low.

GEO. B. DOANE & SON
18 Midway Street, BOSTON
Telephone, Main 4419



Evans 20th Century Arm

Will not twist your shafting pipe. Give it a trial and you will use no other. Three times the power of elbow arms.

Write for Catalogue

QUAKER CITY MACHINE CO.
Richmond, Ind.

Holds Glass Firmly
See the Point **PEERLESS**
FULL SIZE No 2
Glazing Points are the best. No rights or lefts. Box of 1,000 points 75 cts. postpaid.
HENRY A. DREER,
114 Chestnut St., Philadelphia, Pa.

The FLORISTS' HALL ASSOCIATION OF AMERICA, insurer of 29,000,000 sq. ft. of glass. For particulars address **John C. Esler, Sec'y, Saddle River, N.J.**

THE FOLEY MFG. CO.

CHICAGO

Completely equipped with up-to-date machinery for the making of material for

GREENHOUSE CONSTRUCTION

From a Full Supply of Thoroughly Seasoned Lumber

Send your sketches to our draughtsmen for completion and suggestion. Permit us to figure your proposed work, large or small.

We guarantee our prices will save you money

FOLEY VENTILATING APPARATUS IS THE BEST

Simple in Erecting Is Easiest of Operation. It Will Last a Lifetime. Its Price is the Lowest. Will Ventilate Any Size House. Prices and Circulars on Application.

Our 1908 Catalogue Greenhouse Material Sent Postpaid on Request.

THE FOLEY MFG. CO., WESTERN AVENUE, 25th and 26th STS., CHICAGO

CYPRESS SASH BARS
82 feet or longer

HOT BED SASH
PECKY CYPRESS BENCH LUMBER

GREENHOUSES

ERECTED AND EQUIPPED COMPLETE IF DESIRED

Write for Circular "D" and Prices

The A. T. STEARNS LUMBER CO.
NEPONSET, BOSTON, MASS.

In ordering goods please add "I saw it in HORTICULTURE."

I. CASSIDY
Designer and Builder of
Iron and Wood Greenhouses
Factory: Summer Ave and Erie R. R.
Newark, N. J.

EVERYTHING FOR GREENHOUSE BUILDING.

WRITE FOR INFORMATION AND PRICES.

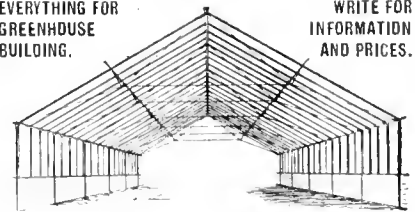

King Greenhouses King Gutters and Eaves. Trussed Roofs. Ventilating Machinery. Trussed Iron Frame Houses. Tile Benches and Pipe Hangers.

KING CONSTRUCTION COMPANY
NORTH TONAWANDA, N. Y.

MASTICA
FOR Greenhouse Glazing
USE IT NOW.
F. O. PIERCE CO.
12 W. Broadway and 227 Greenwich St.
NEW YORK

THE HOUSE OF GREATEST SUNLIGHT

LIGHTEST INTERIOR in the WORLD
THIS HOUSE IS 31.13 FEET WIDE
Note: No Columns

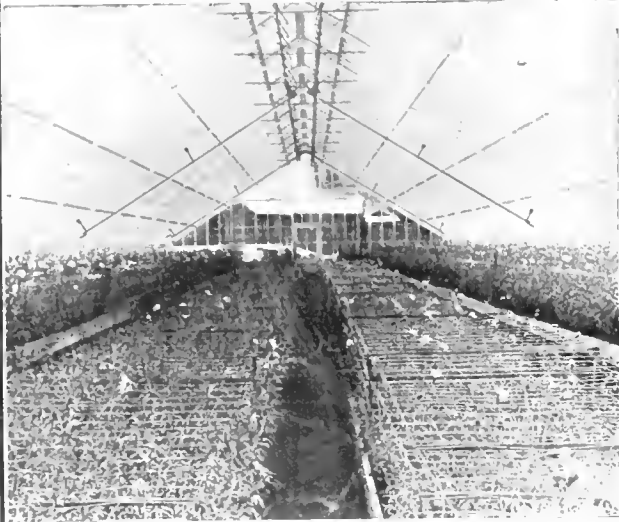

Erected for J. J. BROZAT, Bloomfield, N. J.
BY THE

WEATHERED COMPANY

IRON FRAME, SEMI-IRON FRAME, OR ALL SASH
BAR HOUSES, ERECTED OR MATERIAL ONLY
... SEE OUR CATALOGUE ...

P. O. Address Box 789 NEW YORK CITY, N. Y.

SOMETIMES YOU FORGET

that we make every part of a greenhouse but the glass—and sell any part.

You remember us on the bigger things, but often it never enters your head to think of sending to us for a tub of putty or a few fittings.

But you ought to — and here's why:

Our sole business is manufacturing every part of a greenhouse. We give it, and it only, our undivided attention.

Everything we make is made with an exact knowledge of just what conditions it must meet, and that is why an ever increasing number from all over the country are continually sending us their orders for just the smaller things.

You know how well we do the big things, and if you only stop to think, it is just because of well done little things that it is possible for us to do so thoroughly and enduringly, the big things. So whether white lead, glazing nails, bench fittings, it matters not what, first write to

LORD & BURNHAM CO.

MAIN SALES OFFICE:

1133 BROADWAY, NEW YORK

BOSTON:

819 Tremont Building

PHILADELPHIA:

1215 Filbert St.

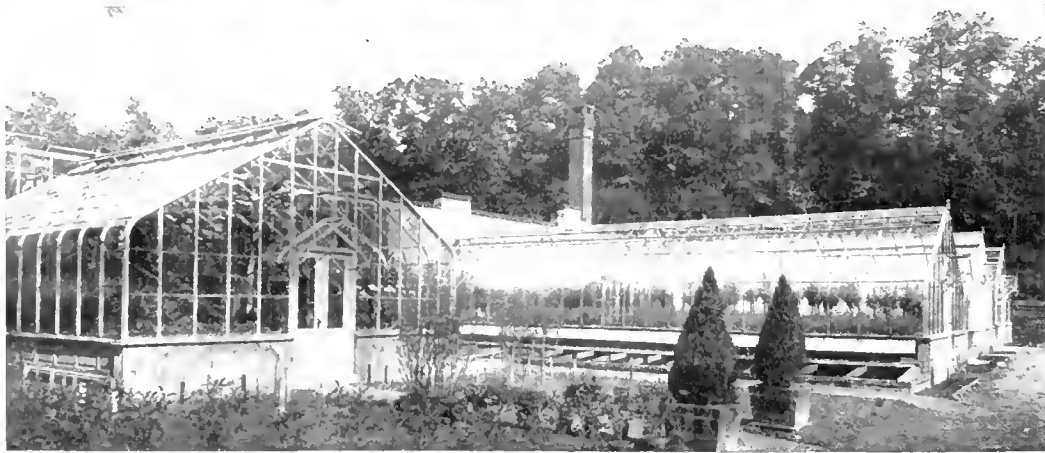

THEY HAVE LESS REPAIRS

because there is less to get out of repair. No points for condensation to settle — all iron heavily galvanized and aluminized. They are the simplest, strongest, lightest, most durable, and attractive houses built, and cost less to maintain and are adaptable to all situations.

The ideal construction for private estates, parks, public institutions and florists' showrooms

U-BAR GREENHOUSES

PIERSON

DESIGNERS AND BUILDERS



U-BAR CO.

1 MADISON AVE. NEW YORK



New York Botanical Garden Library



3 5185 00256 8978

