

MBL/WHOI



0 0301 0010301 6



HOW TO WORK

WITH

THE MICROSCOPE.









# HOW TO WORK

WITH THE

# M I C R O S C O P E .

BY

LIONEL S. BEALE, F.R.S.

FOURTH EDITION,

CONTAINING UPWARDS OF 400 ILLUSTRATIONS, MANY OF WHICH HAVE BEEN  
DRAWN ON THE WOOD BY THE AUTHOR.

LONDON :

HARRISON, PALL MALL.

MDCCCLXVIII.

*The Author reserves the right of translating this Work.*



DEDICATED

WITH EVERY FEELING OF RESPECT AND ESTEEM

TO

MY EARLY AND MUCH VALUED FRIEND

T. G. SAMBROOKE,

WHO HAS ALWAYS EARNESTLY WORKED

TO ADVANCE

GOOD AND TRUE WORK.



## PREFACE.

ALTHOUGH only three years have passed since the last edition of this work was published, the author has considered it necessary to make many changes, to enlarge it, and to alter its form. This edition contains nearly 100 pages more than the last, and 150 additional illustrations have been introduced.

The arrangement of the entire work has been simplified. Several of the articles have been re-written, much new matter upon the examination of tissues introduced, and Part V very much extended.

The author has had the advantage of valuable assistance from several friends. To Mr. Sorby he is indebted for articles on the Examination of Rocks and Crystals, and for an able communication on Spectrum Microscopic Analysis. Dr. Maddox has carefully revised Part IV on Photography, and has added much new matter. Mr. Highley has assisted the author in preparing the section on Collecting and Dredging, and that on Aquaria and Vivaria.

L. S. B.

61, GROSVENOR STREET, W.  
November, 1867.

*Recd. Mar. 28, 1906*  
*Art. 78.*

## PREFACE TO THE FIRST EDITION.

AN earnest desire to assist in diffusing a love for microscopical enquiry, not less for the pleasure it affords to the student, than from a conviction of its real utility and increasing practical value in promoting advancement in various branches of art, science, and manufacture,—a wish to simplify, as far as possible, the processes for preparing microscopical specimens, and the methods for demonstrating the anatomy of different textures,—and the belief that many who possess microscopes are deterred from attempting any branch of original investigation solely by the great difficulty they experience in surmounting elementary detail and mere mechanical operations,—are my chief reasons for publishing this elementary course of lectures, which was delivered during the past winter.

It has been thought desirable to append the tables which I have been accustomed to use in my course of practical demonstrations, for the purpose of enabling everyone to practise for himself the most useful branches of manipulation. Each table will occupy the student about two hours.

Subjoined is a list of the apparatus required for microscopical research, much of which is simple and inexpensive. A number has been added to each instrument, by transmitting which to any instrument maker, the observer will be furnished with the apparatus required.

L. S. B.

## PREFACE TO THE THIRD EDITION.

It is now seven years since the first edition of this work was published, and during this short period very great advance has been made in many branches of microscopical enquiry, both in this country and on the Continent.

Since the publication of the original work, Messrs. Powell and Lealand have succeeded in making, at the request of the author, an object-glass magnifying 1,800 diameters. He hopes shortly to receive from them a power as much superior to this as the  $\frac{1}{2}$ <sup>1</sup>/<sub>8</sub>th is to the old  $\frac{1}{8}$ th. Microscopical science is greatly indebted to these makers for the advances made by them upon several occasions in the manufacture of object-glasses, and in the construction of microscopes.

The author has considered it better to divide the work into *chapters* instead of *lectures*, but the original style has been retained, because it was thought to be well adapted for the description of practical details, in which clearness is of far greater importance than elegance of expression.

The book now contains more than twice the amount of work in the last edition. Many of the paragraphs have been re-written, and three new chapters, containing nearly one hundred pages have been introduced. The number of plates has been increased from 32 to 56.

The author has still further improved upon the mode of injection and preparation of tissues advocated by him and now adopted by many observers. In this edition the details of the particular method of preparation carried out by the author in his investigations with the aid of the highest magnifying powers yet made, are for the first time published.

For the beautiful photograph which forms the frontispiece the author is indebted to his friend Dr. Maddox, who has also afforded him very great assistance in writing the chapter on photography. This is one of the most valuable chapters in the book. It contains the results of many years' most earnest work, by one of the most successful workers in this department of photography. The detail of some of the photographic illustrations is so very minute, that many points cannot be seen by the unaided eye. A lens of low magnifying

power has therefore been appended to the volume, to enable the reader to see the beautiful microscopical details which have been obtained by this mode of illustration, in which Dr. Maddox is striving to achieve still greater success.

Many of the best wood engravings in the volume have been engraved by Miss Powell, to whom as well as to Messrs. Harrison for the great care bestowed in printing, the author's thanks are due.

The author regrets that the book should have been so long out of print, and the publication of the new edition so long delayed. He was anxious to improve it to the utmost of his power and increase its usefulness as a practical work ; and he has, therefore, spared neither time nor trouble, and has refrained from hurrying it through the press, feeling satisfied that time spent in perfecting practical details connected with demonstration, is well employed. For, however some may be inclined to disparage hand work, as distinguished from head work, it is certain that no one can become a good microscopical observer, unless he is possessed of considerable manual dexterity, to be acquired only by long practice ; and no work can be higher or more useful than that of assisting to make men original workers in any department of science, and of encouraging original work. Working books by working men will do far more towards these ends than the most brilliant discoveries, and the author believes that earnest men cannot labour more usefully than by endeavouring to make others work.

61, GROSVENOR STREET, W.

*August, 1864.*



# TABLE OF CONTENTS.

## INTRODUCTION.

### PART I.

THE MICROSCOPE AND GENERAL MICROSCOPICAL APPARATUS  
—OF ILLUMINATING OBJECTS—OF DRAWING, ENGRAVING,  
AND MEASURING—INSTRUMENTS, GLASS CELLS, CEMENTS,  
PRESERVATIVE FLUIDS, AND OTHER THINGS REQUIRED IN  
ORDINARY MICROSCOPICAL WORK.

The microscope. | Simple and compound microscopes.

#### *Optical Portion of the Microscope.*

Negative eye-piece. | Flatness of field.  
Positive eye-piece. | Angular aperture.  
Object-glasses. | The mirror.  
Spherical and chromatic aberration.

#### *Mechanical Portion of the Microscope.*

Adjustment for altering the focus. | The stage.  
The body of the microscope. | Diaphragm.

#### DIFFERENT KINDS OF MICROSCOPES.

Students' microscopes. | Binocular microscopes.  
Large microscopes.

#### *New Binocular for the Highest Magnifying Powers.*

Travelling microscopes. | Clinical pocket, travelling, or class  
Travelling, dissecting, and vivarium | microscope.  
microscopes. | Dissecting microscopes.  
Apparatus necessary for the student.

#### OF ILLUMINATING OBJECTS.

Reflected light. | Transmitted light, and polarised light.

#### *Sources of Illumination.*

Artificial illumination.

#### *Lamps.*

Paraffine lamps. | Gas lamps.

27676

*Of examining the Surface of Objects by Reflected Light.*

Bull's-eye condenser.	Arrangement for examining opaque objects by very high powers. Dark ground illumination. The parabolic reflector.
Metallic reflector.	
Beck's parabolic reflector.	
Lieberkuhn.	

*Of examining the Internal Structure of Objects by Transmitted Light.*

Transmitted light.	Gillett's condenser. New condensers. Examination of objects.
Monochromatic illumination.	
Diaphragm.	
Achromatic condenser.	

## OF DRAWING AND ENGRAVING OBJECTS.

Of drawing objects.	Of obtaining lithographs from microscopical drawings. Drawing on transfer paper. Transfer paper. Drawing on the stone. Engraving on stone. Lithographic ink. Of representing peculiarities of texture. On the importance of observers delineating their own work.
Camera lucida.	
Steel disk.	
Neutral tint glass reflector.	
Arranging light.	
Of making drawings which are to be engraved.	
Pencils.	
Tracing and re-tracing paper.	
Wood blocks.	

## ON MEASURING OBJECTS AND ASCERTAINING THE MAGNIFYING POWER OF OBJECT GLASSES.

The cobweb micrometer.	To ascertain the diameter of an object. Standards of measurement. Conversion of foreign standards of measurement.
Jackson's eye-piece micrometer.	
Stage micrometers.	
Test objects.	
Simple method of measuring.	
On ascertaining the magnifying power of object-glasses.	

*Of finding the same Spot in a Specimen.*

Of making the position of an object.	Mr. Bridgman's finder.
--------------------------------------	------------------------

## INSTRUMENTS AND APPARATUS REQUIRED IN GENERAL MICROSCOPICAL RESEARCH.

Spirit lamps.	Brass plate. Water bath.
Wire retort stand.	
Tripods.	

*For cutting Thin Sections of Tissues.*

Scalpels.	Scissors. Needles. Forceps. Wooden forceps.
Double-edged knife.	
Section knife of a new form.	
Double-bladed or Valentin's knife.	
Razor.	

*Glass Slides, Thin Glass, Watch Glasses, Glass Shades.*

Plate-glass slides.	Watch glasses. Glass shades.
Thin glass.	

*Cements.*

Gold size.	Marine glue. Cement for attaching gutta percha or India-rubber to the glass slides. Canada balsam.
Sealing wax varnish.	
Solution of shell-lac.	
Bell's cement.	
Brunswick black.	

*Vessels for keeping Canada Balsam in.*

Solutions of Canada balsam. Arrangement for pressing down the thin glass cover while the balsam or cement is becoming hard.	Gum. French cement composed of lime and India-rubber.
--	--

## PRESERVATIVE FLUIDS.

Spirit and water. Glycerine. Thwaites' fluid. Solution of naphtha and creosote. Carbolic acid. Solution of chromic acid. Preservative gelatine. Gelatine and glycerine.	Gum and glycerine. Goadby's solution. Burnett's solution. Chloride of calcium. Alum and other salts. Arsenious acid. Arseniuretted hydrogen.
--	--

## CELLS FOR PRESERVING MICROSCOPICAL SPECIMENS.

Paper cells. Shell-lac cells. Brunswick black cell.	Marine glue cells. Cells made of tinfoil.
---	--

*Of Glass Cells.*

Cutting and grinding glass. Stone for grinding. Of drilling holes in glass. Cementing glass together with marine glue. Cleaning off superfluous glue. Cells made of thin glass. Simple methods of perforating the thin glass. Deeper glass cells.	Small deep cells for injections. Built glass cells. Deep glass cells made by bending a strip of glass in the blowpipe flame. Moulded glass cells. Gutta percha and ebonite cells. Round cells. Troughs for examining zoophytes. Animalcule cage. Growing cells.
--	---

## PART II.

## OF PREPARING AND PRESERVING OBJECTS FOR THE MICROSCOPE—SEPARATING DEPOSITS FROM FLUIDS—OF INJECTING—OF DEMONSTRATING THE STRUCTURE OF THE FULLY-FORMED TISSUES OF MAN, THE HIGHER AND LOWER ANIMALS, AND PLANTS—OF EXAMINING MINERALS AND FOSSILS.

## OF THE IMPORTANCE OF EXAMINING THE SAME OBJECTS IN DIFFERENT MEDIA.

Appearance of the same object examined in air, water, and Canada balsam, by transmitted light, and under the influence of reflected or polarised light. Of air bubbles and oil globules, and globules of crystalline matter. For beginners only. How to examine an object in the microscope. Precautions to be observed in working.	General considerations with reference to the nature of the medium in which tissues should be placed for examination. Examining and preserving specimens in the dry way. Examination of substances in fluids. Examination in Canada balsam, turpentine, and oil.
--	--

## OF PREPARING TISSUES FOR MICROSCOPICAL EXAMINATION—OF DISSECTING AND CUTTING THIN SECTIONS OF TISSUES.

Of making minute dissections. Loaded corks.	Tablets upon which dissections may be pinned out.
--	---

*Cutting Thin Sections of Soft Tissues.*

Of obtaining thin sections of different textures for microscopical examination.	Of cutting sections and handling bodies under the microscope.
---	---

*On an Instrument for making Sections on the Stage of the Microscope.*

Mechanical finger. Dissecting tissues 'under the microscope with the compressorium.	Cutting sections of tissues which have been previously dried. Hardening the tissue.
--	--

*Of cutting Thin Sections of Hard Tissues.*

Of making thin sections of dry bone. Teeth. Sections of shells.	Horn and hair. On cutting sections of wood and textures of that character.
---	---

## ON THE SEPARATION OF DEPOSITS FROM FLUIDS.

Conical glasses. The pipette. Removing the deposit with the pipette. On separating the coarse from the finer particles of a deposit.	Separation of deposit when very small in quantity. Examination of the deposit. Wash bottle.
---	---

## ON MAKING INJECTIONS.

Of natural and artificial injections. Instruments required for making injections.	Injecting cans.
--	-----------------

*Of Opaque Injections.*

The size. Colouring matters. Vermilion. The chromate of lead. The carbonate of lead.	Size of the particles of the colouring matter used. Of injecting different systems of vessels with different opaque injections.
--	--

*On Transparent Injections.*

Advantages of transparent injections. Injection of plain size. Colouring matters for transparent injections. Advantages of employing Prussian blue. Prussian blue fluid. Turnbull's blue.	Carmine injecting fluid. Acid carmine fluid. Dr. Carter's carmine injecting fluid. Of injecting different systems of vessels with transparent injections. New form of soluble Prussian blue. Mercurial injection.
--	--

*Of injecting the Vessels of the Higher Animals.*

Of the practical operation of injecting. Of the pressure required for successful injection.	Of injecting the ducts of glands. Of injecting lymphatic vessels.
--	--

*Of injecting the Lower Animals.*

Insects. Mollusca. Mr. Robertson's plan of injecting the snail.	Injecting fishes. Of preparing portions of injected preparations for microscopical examination.
---	--

*Injections as Moist Specimens and mounted in Canada Balsam.*

Of the best mode of destroying the life of animals intended for injection.
--

## OF STAINING TISSUES.

Of colouring the germinal or living matter.	Anilin colours.
Process of staining followed by Rev. Lord S. G. Osborne.	Blue colours for staining.
Gerlach's method of staining.	Tannin.
The author's carmine fluid.	Solutions of nitrate of silver.
Thiersch's carmine fluid.	Solutions of chloride of gold.
Thiersch's lilac colouring fluid.	Solution of osmic acid.
	Other metallic salts.
	Modification of the foregoing plans.

## OF DEMONSTRATING THE DIFFERENT STRUCTURES OF THE HIGHER ANIMALS.

On structure. General observations.	General directions for the examination of a soft tissue.
On demonstrating the anatomical peculiarities of tissues.	

*Examination of the Simple Tissues.*

Areolar tissue.	Adipose tissue.
White fibrous tissue.	Cartilage.
Yellow fibrous tissue.	Bone.

*Examination of the Higher Tissues.*

Examination of muscular fibre.	Examination of arteries and veins.
Sarcolemma.	Examination of the capillaries.
Branched muscular fibres.	Examination of nerve.
Preparation of muscular fibre for microscopical examination.	<i>Dark-bordered nerve fibres.</i>
Examination of unstriped muscle.	<i>Pale-grey, or sympathetic nerve fibres.</i>
Examination of the muscular structure of the heart and tongue.	

*Examination of Serous and Mucous Membranes.*

Examination of serous and synovial membranes.	Examination of mucous membrane.
---	---------------------------------

*Examination of Organs of Digestion and Absorption.*

Epithelium.	Of the movements of the chyle.
Villi, muscular fibres, lacteals.	

*Organs of Circulation.*

Blood corpuscles.	Of the action of the heart.
Of the circulation of the blood.	

*Organs of Respiration.*

Lung.	Trachea.
-------	----------

*Organs of Secretion.*

Salivary glands and pancreas.	Kidney. The anatomy of glandular organs more easily demonstrated in the lower animals than in man and the higher animals.
Liver. General examination.	
On demonstrating the structure of the liver.	
Of injecting the ducts of the liver.	
	Basement membrane, matrix, and vessels.

*Organs of Innervation.*

Examination of the brain.	Examination of the nerve ganglia.
Examination of the spinal cord.	

## OF COLLECTING, KEEPING ALIVE, AND EXAMINING THE LOWER ANIMALS.

Of collecting and dredging.		Of keeping bodies moist while under microscopical observation.
Vivaria and aquaria.		Of keeping bodies moist at a uniform temperature higher than the air while under microscopical observation.
Examination of lower animals during life.		
Examination of infusoria.		
Examination of vorticellæ and rotifers.		

*Of the Tissues and Organs of the Lower Animals.*

Of preparing the tissues of insects for microscopical examination.		Branchiæ of mollusca.
The scales and hairs of insects and crustacea.		Microscopic shells.
Tracheæ.		Contractility of muscle.
		Ciliary movement.

## OF DEMONSTRATING THE TISSUES OF PLANTS.

Examination of vegetable tissues.		Of preserving vegetable tissues perma- nently.
Of the circulation in the cells of certain plants.		Of collecting and mounting diatoms.

OF THE MOVEMENTS OF LIVING BEINGS, AND OF PURELY VITAL MOVEMENTS  
—PRIMARY OR VITAL MOVEMENTS—SECONDARY MOVEMENTS.

Of the primary or vital movements oc- curring in living beings.		Of the secondary movements occurring in living beings.

*Of Molecular Movements—Movements of Granules within Cells.*

Of growth and multiplication.

## OF THE EXAMINATION OF ROCKS, CRYSTALS, AND FOSSILS.

Of the anatomy of crystals.		Of measuring the angles of crystals.
Of the use of polarised light.		Of preparing fossils for microscopical examination.
Crystals of one mineral enclosed in another.		Of preparing specimens of coal for micro- scopical examination.
On making sections of rocks and crystals.		
Of the microscopical structure of iron and steel.		

THE WORK TABLE—OF MAKING AND RECORDING OBSERVATIONS—FALLACIES  
TO BE GUARDED AGAINST.

The work table.		Of the importance of making sketches.
Of keeping preparations in the cabinet.		Of drawing inferences from observation.
Of making observations upon specimens in the microscope.		Of recording the result of microscopical observations.

*Fallacies to be guarded against in Microscopical Investigation.*

Errors of observation.		Collections of oil globules appearing as if within a cell.
On the difficulty of seeing structures from their transparency.		On the accidental presence of extra- neous matters.
Fibres and membranes produced by the action of reagents artificially.		
Fibrous appearances produced in struc- tureless membranes.		

## PART III.

## OF CHEMICAL ANALYSIS APPLIED TO MICROSCOPICAL INVESTIGATION—OF OBTAINING CRYSTALLINE SUBSTANCES—OF SPECTRUM MICROSCOPICAL ANALYSIS.

## OF THE ADVANTAGES OF CHEMICAL REAGENTS IN MICROSCOPICAL INVESTIGATION.

Of chemical analysis in microscopical investigation.	Evaporation and drying.
Instances of the use of reagents.	Incineration.
Preliminary operations.	Apparatus.
Reaction.	Microscope for examining substances immersed in acids and corrosive fluids.
On Filtering.	

## REAGENTS AND THEIR ACTION.

Distilled water.	Effects of acids on organic structures.
Alcohol.	Solution of potash.
Ether.	Solution of soda.
Effects of alcohol and ether.	Ammonia.
Nitric acid.	Effects of alkalis on organic structures.
Sulphuric acid.	<i>Nitrate of silver.</i>
Hydrochloric acid.	Nitrate of barytes.
Acetic acid.	Oxalate of ammonia.
Chromic acid.	Iodine solutions.

## OF APPLYING TESTS TO MINUTE QUANTITIES OF MATTER.

Method of applying tests to substances intended for microscopical examination.	Testing for carbonate and phosphate of lime, phosphate of ammonia and magnesia, sulphates and chlorides.
Bottles with capillary orifices.	New method of microscopical analysis.
Capillary tubes with India-rubber tied over the top.	

*Of obtaining Crystalline Substances from the Fluids and Textures of Organisms.*

Formation of crystals.	Examination of crystals under the microscope.
Influence of various constituents upon the crystallisation.	Preservation of crystals as permanent objects.
Separation of crystals from animal substances.	Of the hardening properties of different chemical solutions.
Of obtaining crystals for examination.	

## ON SPECTRUM ANALYSIS, BY H. C. SORBY, F.R.S., &amp;c.

The spectrum microscope.	Method of measuring the position of absorption bands.
Of examining objects in the spectrum microscope.	Substances giving well-marked absorption bands.
Examination of blowpipe beads, and solutions in cells.	

## PART IV.

## ON TAKING PHOTOGRAPHS OF MICROSCOPICAL OBJECTS—APPARATUS—ILLUMINATION—CHEMICAL SOLUTIONS—PRACTICAL MANIPULATION—PRINTING—PHOTOGRAPHS FOR THE MAGIC LANTERN.

History of the application of photography to the microscope.	Illumination.
--	---------------

APPARATUS.

Camera with object glasses and stage adapted to it.	Arrangement of Drs. Abercrombie and Wilson.
Mr. Wenham's arrangement without a camera.	Of the illumination : sunlight : monochromatic light : polarising apparatus.
Dr. Woodward's method.	Artificial light.
Camera applied to the ordinary microscope.	Of focussing.
Dr. Maddox's camera.	Of the object glasses.
Dr. Maddox's arrangement for working without a camera.	Stereoscopic photographs.

CHEMICAL SOLUTIONS REQUIRED.

Collodion.	Inserting the plate.
Nitrate bath.	Developing the image.
Of the developing solutions.	Of increasing the intensity of the negative.
The fixing solutions.	Varnishing the plate.
Cleaning the plates.	Of cleaning old plates.
Arranging the camera.	

PRINTING.

Preparing the paper.	Fixing solution.
Toning solution.	Mounting the prints.
Another toning solution.	

PHOTOGRAPHS FOR THE MAGIC LANTERN.

Magnesium light.
Photographs of microscopic objects for the magic lantern.

PART V.

OF THE HIGHEST MAGNIFYING POWERS YET MADE AND OF THE BEST METHODS OF USING THEM—NEW METHOD OF PREPARING SPECIMENS FOR EXAMINATION WITH THE HIGHEST POWERS — NEW VIEWS CONCERNING THE STRUCTURE, GROWTH, AND NUTRITION OF TISSUES, AND ON LIFE.

Apology for the use of very high magnifying powers.	Illumination of objects magnified by very high powers.
Of the highest magnifying powers.	Method of increasing the size of the image without altering the object glass.
“Immersion” twenty-fifth.	Of drawing objects magnified by very high powers.
Of the one-fiftieth objective.	
The apparent size of an object under different powers.	
Of the covering glass.	

NEW METHOD OF PREPARING SPECIMENS FOR RESEARCHES WITH THE AID OF THE HIGHEST MAGNIFYING POWERS YET MADE.

Conditions to be fulfilled in demonstrating minute structure by the highest powers.	Glycerine and syrup.
Action of glycerine and syrup on tissues.	The injecting fluid.
Of the advantages of viscid media for the dissection of tissues or examination with the highest powers.	Other colouring solutions with glycerine.
The carmine fluid for staining germinal matter.	Glycerine and water, and glycerine and acetic acid for washing and preserving thin sections.



*On Chemical Reagents dissolved in Glycerine.*

Acetic acid syrup.		Of the injection of solutions of various chemical compounds dissolved in glycerine.
Solutions of potash and soda.		
Solutions of chromic acid and bichromate of potash.		

*The Preparation of Specimens.*

The practical operation of preparing tissues for examination with the highest powers.		teeth, &c., for examination with the highest powers. The preparation of embryonic tissues for examination with very high powers.
Modification of the above plan.		
Of the preparation of hard tissues, bone,		

## NEW VIEWS UPON THE STRUCTURE, FORMATION, AND GROWTH OF TISSUES AND ON LIFE.

Of the smallest masses of living or germinal matter.		Of the nucleus. Of the term cell. False cells. Of the nutrition and action of the cell.
The characters of germinal or living matter and its conversion into formed material.		
Nature of "irritation" and "inflammation."		

## OF VITAL POWER.

Of life.		Of living and dead.
----------	--	---------------------

## THE STRUCTURE AND ACTION OF A NERVOUS APPARATUS.

Of plexuses and networks.		Of caudate nerve cells. Of spherical and oval nerve cells.
The distribution of motor nerves to muscles.		
Nerve fibres distributed to organs of special and general sensation.		

## APPENDIX.

Of the use of borax and boracic acid.		Dr. Woodward's improved arrangements for taking photographs of microscopic objects.
New colouring matter developed by living organisms, and giving very peculiar spectrum bands.		

## TABLES FOR PRACTISING THE USE OF THE MICROSCOPE.

## APPARATUS REQUIRED IN MICROSCOPICAL INVESTIGATION.

## BRITISH AND FOREIGN MICROSCOPE MAKERS.

## PREPARERS OF MICROSCOPIC OBJECTS.

## MATERIALS AND APPARATUS FOR MOUNTING OBJECTS.

## ARTISTS, DRAUGHTSMEN, WOOD ENGRAVERS.

## PRINTERS, LITHOGRAPHIC, AND PHOTO-LITHOGRAPHIC PRINTERS.

## LITHOGRAPHIC STONES, DIAMONDS FOR ENGRAVING, AND APPARATUS USED IN LITHOGRAPHY.

## APPARATUS FOR DRAWING ENGRAVINGS, &amp;c.

## BRITISH AND FOREIGN WORKS ON THE MICROSCOPE, INCLUDING JOURNALS.

## INDEX.

## INDEX TO THE ILLUSTRATIONS.

## TO THE READER.

This work may be “read” by studying the drawings, with occasional reference to the text. A description of each figure is appended to it, and in most cases the page in which the subject is treated of, is noted. The student will obtain more correct ideas, and in a shorter time, by the attentive examination of the illustrations than by reading only.

# HOW TO WORK

WITH

# THE MICROSCOPE.

---

INTRODUCTION.

**I. Importance of Microscopical Manipulation.**—Manual dexterity, although subordinate to many higher qualifications, is absolutely necessary to the successful prosecution of every kind of experimental science. It greatly assists us in the discovery of new methods of enquiry, and in devising ingenious ways by which difficulties may be surmounted. Without skilful manipulation, we can neither teach by demonstration facts which have been already discovered, nor hope to extend the bounds of existing scientific knowledge. It is not therefore surprising that many of the most important facts which have been recently added to microscopical science, have been discovered by men who had previously well trained themselves in experimental investigation,—particularly in practical chemistry; who had learnt by long experience and careful observation, that improvement in the practical details of manipulation almost necessarily precedes an advance in natural knowledge, and invariably promotes and expedites true scientific progress.

The main object of this work is to instruct learners in microscopical manipulation, and in the performance of those operations which are essential to the successful demonstration of form, structure, and colour, under the microscope. To manipulate well is no matter of mere practice, it requires much mental application and power.

There are perhaps few things upon which more misapprehension exists among young men than the importance of mastering elementary

## PART I.

THE MICROSCOPE AND GENERAL MICROSCOPICAL APPARATUS—OF ILLUMINATING OBJECTS—OF DRAWING, ENGRAVING, AND MEASURING — INSTRUMENTS, GLASS CELLS, CEMENTS, PRESERVATIVE FLUIDS, AND OTHER THINGS REQUIRED IN ORDINARY MICROSCOPICAL WORK.

**2. The Microscope.**—It is not desirable in a practical work like the present, to enter into minute details, concerning either the mechanical or special arrangements of the microscope, especially as there are many excellent books published in this country, in America, and on the Continent, in which these points are fully discussed. I shall therefore allude only in general terms, and as briefly as possible, to the various parts of which the microscope is composed.

**3. Simple and Compound Microscopes.**—The *simple microscope*, fig. 2, pl. I, is of use chiefly in the examination and dissection of comparatively large objects. It consists of a firm support, on which the stage or rest for the object is placed, the mirror being beneath, and the object glass above. In this arrangement the magnified image of the object passes at once to the eye of the observer.

The *compound microscope* is the only one now used for microscopical research. Until those great improvements in the mode of combining the glasses, now universally adopted, had been introduced by the successful labours of Mr. Lister, Mr. Ross, and others, the compound microscope was a very imperfect instrument, and even up to the present century the simple microscope, as employed by Leeuwenhoek, and improved by Wollaston and others, possessed many advantages over its more complex but imperfect rival.

In the *compound microscope*, fig. 1, the object is magnified in the first instance by the *object-glass*, c, and brought to a focus within the tube, as represented at a, in the diagram. This magnified image is again magnified by the *eye-piece*, b. The image is of course inverted, but this inconvenience may be obviated by causing it to pass through another set of lenses inserted in the tube of the microscope, and termed the *erector*. This instrument consists of a tube, at one end of which is a plano-convex lens, and at the other a meniscus, a diaphragm being placed about midway. This is inserted in the tube

of the microscope above the object-glass, and, like the same arrangement in the telescope, reverses the image.

The magnifying power of the compound microscope may be augmented either by increasing the power of the *object-glass* or that of the *eye-piece*, or by increasing the distance between the object-glass and the eye-piece. It must be borne in mind, however, that in increasing the power of the eye-piece we do not magnify the *object* itself in a greater degree, but simply increase the size of the *image* of the object formed by the object-glass. Any imperfections which may exist in the object-glass are thus greatly augmented. Hence we should never work with deep eye-pieces, but when we wish to magnify an object more, we should adapt a higher power to the instrument. Information upon employing very high powers will be found near the end of the work. It will be convenient for me to allude in the first place to the *optical portion* of the microscope, and secondly to the *mechanical appliances* for moving the object, altering the focus, &c. The *optical portion* includes the eye-piece, object-glass, and the mirror from which the light is reflected so as to pass through the object.

#### *Optical Portion of the Microscope.*

**4. Negative Eye-piece.**—The *eye-piece* in ordinary use is the *negative* or *Hughenian* eye-piece, fig. 3, pl. I. It consists of two plano-convex glasses, the flat surfaces of each being directed upwards. The one nearest the eye of the observer is the *eye-glass*, and the one at the greater distance the *field-glass*.

*Kelner's eye-piece* is made like the above, but the eye-glass is an achromatic combination. At the suggestion of Mr. Brooke I have lately used this eye-piece as a condenser with the best results.

**5. The Positive Eye-piece.** of Ramsden, is only used in those cases in which it is necessary to see distinctly some object in the eye-piece, as an instrument for measuring, at the same time that the object itself is in focus. In this the convex surfaces of each of the two glasses are directed towards each other as represented in fig. 4.

**6. Object-glasses.**—The *object-glasses*, fig. 7, pl. I. used in the best instruments are of English manufacture, but some of those furnished with the cheap microscopes are made on the Continent, and are much less expensive.

The two most useful object-glasses for the student are the *quarter of an inch* which, with the No. 1 eye-piece, should magnify from 200 to 220 diameters, and the *inch* which should magnify from 30 to 40

diameters. The definition of these glasses should be good, and they should transmit plenty of light. Any lines in a structure examined by them should appear sharp and distinct. The field should be flat, every part of it in focus at the same time, not too small, and there should be no coloured rings round any object subjected to examination. The achromatic object-glasses consist of three sets of lenses, each of which is itself compound, but Mr. Wenham has made some excellent high powers with a *single* front lens. An important improvement in the making of object-glasses has been recently made by Mr. Wales, of Fort Lee, New Jersey, who at the suggestion of Prof. H. L. Smith, of Kenyon College, U.S., has added a second posterior combination, which may be substituted for the ordinary one when objects are to be examined with very oblique light. The arrangement also possesses some advantages for photographic purposes.

Some object-glasses of high power are now made so that the object must be viewed through a thin stratum of distilled water placed between and touching the surfaces of the front lens of the objective and the covering glass (*à immersion*). The image has a peculiar brightness, and as Mr. Brooke has observed, the object is more highly illuminated, because more oblique rays are admitted than would otherwise pass into the lens; the working distance of the objective is somewhat increased, while the price of glasses of the same magnifying power is less. Immersion object-glasses were first made by M. Hartnack, of Paris, the successor of Oberhäuser, but others, as M. Merz, of Munich, and M. Hasert, of Eisenach, have since produced them.

The use of objectives of very high magnifying power is discussed in another part of this volume.

**7. Spherical and Chromatic Aberration.**—Unless the objective is properly corrected for spherical and chromatic aberration, pl. I, figs. 5 & 6, it is valueless to the observer. *Spherical aberration* may be known by the want of sharpness when a fine line or small spot, or body with a well-defined circular outline is examined. Instead of the lines appearing sharp and distinct and definite, they seem to be blurred and foggy, even when focussed with the utmost care, and when there are several lines or spots near to one another, they appear to run together, producing a general shadow, instead of each one being distinctly defined and separated from its neighbours. If the glass has not been properly corrected for *chromatic aberration*, lines are seen with coloured fringes, *blue* if the lens is *under-corrected*, reddish if *over-corrected*.

**8. Flatness of Field** can be tested by moving an object from one

part of the field to another without altering its distance from the object-glass. If the field is flat, the object will appear equally well-defined in all parts, but if the glass is defective in this particular, an object accurately focussed in the centre will be found to be blurred and out of focus when it is moved to the circumference. Or a stage micrometer, § 60, ruled to hundredths and thousandths of an inch may be brought into focus. If the lines are sharp and clear, and perfectly parallel with one another in every part of the field, the glass is a good one; but if some appear curved and thicker at the circumference of the field than at its centre, the glass is defective.

It is not to be supposed that, even if the most minute directions were given, the student just commencing work would be able to test the object-glasses he was about to purchase, in all necessary particulars. Generally he may trust the maker, but if he desires to ascertain if his object-glass is good, perhaps the simplest plan is to compare the images produced by the same object first placed under his own power and then under a glass magnifying in the same degree, but of known excellence.

**9. Angle of Aperture.**—For ordinary work it will be found inconvenient if the object-glass, when in focus, comes too close to the object. This is a defect in glasses having a high *angle of aperture*. The angle of aperture is the angle made by two lines from opposite sides of the aperture of the object-glass with the point of focus of the lens. The angle B A B in fig. 8 is the angle of aperture. Glasses with a high angle of aperture admit much light, and define many structures of an exceedingly delicate nature, which look confused when examined by ordinary powers, but for general work I recommend glasses of medium angular aperture.

Mr. Ross has lately made glasses having an angle of 170 degrees, which are valuable for investigations upon many very delicate and thin structures, such as the diatomaceæ; but such powers are not well adapted for ordinary work. The importance of arranging the object very carefully and the necessity of paying great attention to the adjustment and illumination, render these glasses inconvenient for general observation. The *penetrating power* of glasses with a low angle is much greater than in those of a high angle of aperture, so that exact adjustment is much more important in the latter than in the former.

The refraction produced by the passage of the light through the thin glass covering the object varies according to its thickness, and it has been found necessary to render the higher powers capable of being adapted to this varying refraction. It is especially necessary in glasses of high angle of aperture, and is usually effected by

altering the distance between the front and second pair of glasses. An engraved line shows the point to which the lens should be set for *uncovered object*. Its adjustment for *covered* objects is to be effected in the following manner:—arrange the objective as if for an *uncovered* object; then any object covered with thin glass is brought into focus by moving the body of the microscope; next the milled adjustment ring adapted to the object-glass is turned round until any particles of dust upon the upper surface of the thin glass covering the object are brought into focus. The lens is thus “*corrected*” for the thickness of the cover, and it only remains to re-focus the object.

The mechanical arrangement usually employed in this country for “correcting” is unsatisfactory. The screw usually works too hard, and the thread is too coarse. Mr. Wenham has introduced a great improvement, which entirely overcomes these objections, and enables the observer to “correct” from time to time while he is examining the object. The middle and posterior lenses are made to alter their position instead of the front lens. This is a very valuable improvement.

**10. The Mirror**, pl. V, fig. 19, should slide upon an upright beneath the stage, so that it may be arranged near to, or at a distance from, the object, and it should be capable of being inclined at any angle, so that rays of light may be reflected from it and made to pass directly through the object in straight lines, or thrown upon it in a very oblique direction. The mirror should be of full size, one surface quite plane and the other concave, so that a strong light may be condensed upon the object when required. The achromatic condenser and other pieces of apparatus of advantage for examining objects by transmitted and reflected light are described in Part II.

### *Mechanical Portion of the Microscope.*

In directing attention to the mechanical arrangements of the microscope, I must say a few words upon the adjustments for altering the focus, the body of the instrument, and the stage.

**11. Adjustments for altering the Focus.**—The ordinary movement is obtained by the rack and pinion. In some microscopes the body is moved by the fingers alone, and is arranged to slide in a tube (which may be lined with cloth) like a telescope. In the instruments of Mr. Ladd the requisite motion is obtained by the ordinary milled head, while delicate focussing is carried out by a lever, but the movement is effected by a chain instead of rack and pinion. Besides coarse adjustment, however, every microscope should be provided



Fig. 1.



Diagram of compound microscope. A point where the object is brought to a focus in the objective glass. C the image formed at this point is magnified again by the eyepiece B. p. 4.

Fig. 2.

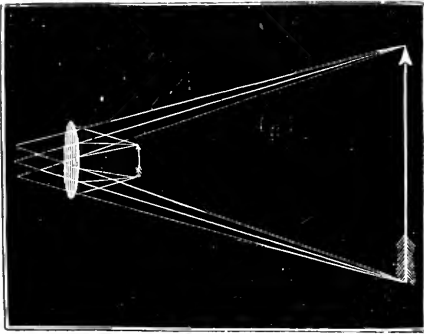
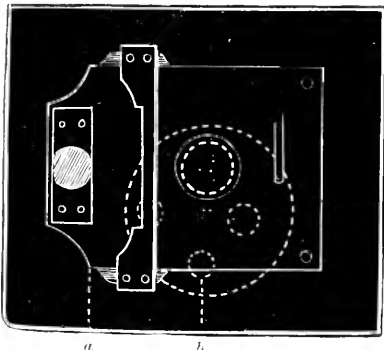


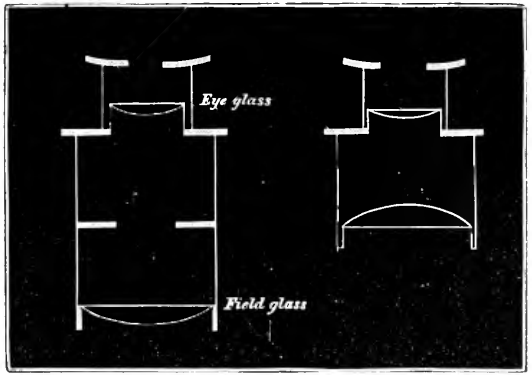
Diagram of simple microscope. p. 4.

Fig. 3.



State of student's microscope showing dark film placed beneath. From a, b where it is not less than two inches. p. 5.

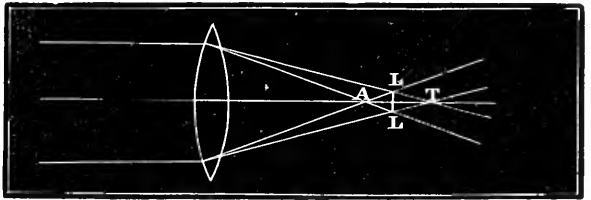
Fig. 3.



Nature of light passing through eye glass. p. 5.

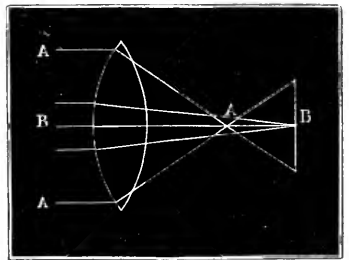
Nature of light passing through field glass. p. 5.

Fig. 5.



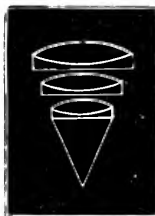
To illustrate the formation of a virtual image and the rays which make up the same. Rays of light from a distant object are brought to a focus A behind the lens. Rays from a nearer object pass the focus A, T will be the least refrangible of the rays of the spectrum. Any object placed at LL would exhibit colored fringes. p. 6.

Fig. 6.



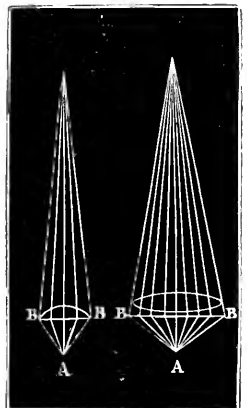
To illustrate spherical aberration. The rays AA tend to converge at a point nearer the center B. The rays BB are brought to a focus nearer the lens. p. 6.

Fig. 7.



Compound classes of an achromatic object glass. p. 6.

Fig. 8.



a - lens with three unequal apertures. BAB  
b - lens with high index of aperture. BAB  
p. 7.



with a more delicate motion for altering the focus when high powers are employed. The details of the arrangement of the *fine adjustment* are different in various instruments. The movement of Mr. Ladd's chain is so regular and delicate as to supersede the necessity of a fine adjustment.

**12. The Body of the Microscope.**—The instrument should be perfectly steady, whether the body be inclined or arranged in a vertical position; and not the slightest lateral movement or vibration should be communicated to the body of the microscope when the focus is altered by turning either of the adjustment screws. The base or foot should be sufficiently heavy to give steadiness, and should touch the ground in three places only, or the body should be fixed upon three feet.

The body ought to be provided with a joint by which it may be inclined or placed in a horizontal position, which is required when drawings are made with the camera, or when objects are measured by the aid of the instrument. Another advantage gained by this moveable joint is that the muscles of the observer's neck do not become so tired when the body of the microscope is inclined as when the head has to be bent, for several hours at a time, over an instrument standing upright. The larger the microscope may be, the more necessary is this joint for the comfort of the observer; and as it in no way impairs the steadiness of the instrument, and only adds a few shillings to the expense, I recommend every one, in choosing a microscope, to select an instrument which may be placed in a vertical, inclined, or horizontal position.

**13. The Stage** should be at least three inches in length by two and a half in width, and there should be a distance of at least an inch and a half from the centre of the opening in the stage over which the slide is placed, to the upright pillar *a*, fig. 9, pl. I. The stages of the microscopes of Nacet, Oberhäuser, and some other foreign makers are too contracted for convenience.

**14. Diaphragm.**—Beneath the stage a circular diaphragm plate with holes in it of several different sizes, should be so arranged that it can be made to revolve without difficulty and any hole brought under the object; a catch is of great advantage in placing the hole in the centre of the field, fig. 9. Various arrangements have been adopted for altering the size of the aperture in the diaphragm instead of having a revolving plate with holes of different sizes. One of the most ingenious is that devised by Mr. B. Kincaid (*Mic. Journal*, July, 1866, p. 75). This is made of a short piece of thin India-rubber tube, the two ends of which, fixed to brass rings, are made to revolve in opposite directions so that the central part becomes contracted.

Any-sized aperture may be obtained, and the opening must be always perfectly central. The graduating diaphragm made by Mr. Collins is, however, the most useful diaphragm yet made, pl. XIII, fig. 59.

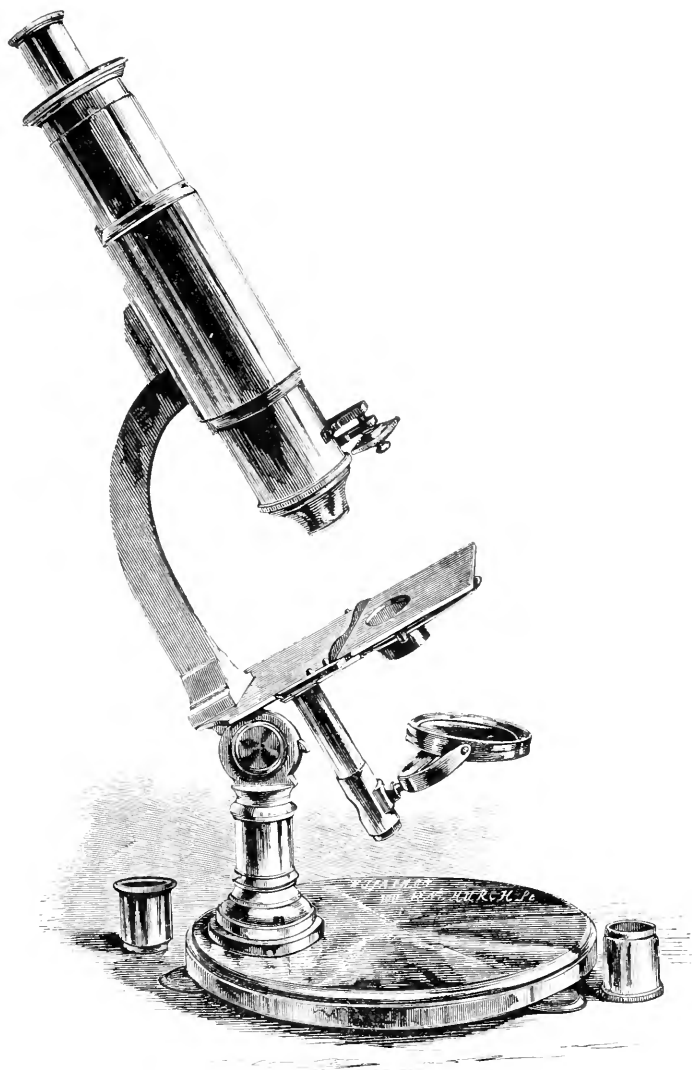
#### DIFFERENT KINDS OF MICROSCOPES.

**15. Students' Microscopes.**—Mr. Salmon (1853), Mr. Highley, and Mr. Matthews were, as far as I know, the first makers in London who brought out a really good, cheap, practical instrument, furnished with foreign object-glasses. Two of Mr. Highley's microscopes are represented in pl. III, figs. 11, 12; Mr. Salmon's student's microscope is represented in pl. II. The microscopes of Mr. Ladd are thoroughly well made; and Messrs. Murray and Heath's new microscope (74) is a very good and most convenient instrument. I would strongly recommend all who are about to purchase a student's microscope to examine the instruments of these makers, as well as the new microscope of Messrs. Smith and Beck, which costs five pounds, the students' microscopes made by Mr. Collins, of Titchfield Street, and the very cheap instruments of Mr. Baker, Holborn.

**16. Large Microscopes.**—The large expensive microscopes are provided with every instrument which modern science has placed at the disposal of the observer. For delicate investigations many of these are invaluable, but for ordinary work they are not necessary, and their expense is so great as to place them beyond the reach of the great majority of students. Very expensive and delicate instruments are seldom necessary for ordinary work, and on those few occasions when a very perfect instrument is required, the student may appeal to some friend, who possesses a large microscope, for permission to examine his object by it. The members of the Microscopical Society have the advantage of using under certain regulations most beautiful instruments provided with very high powers. A very complete one has been liberally placed at the disposal of the Society by Mr. Ross. These microscopes are now arranged ready for work at the rooms used by the Society at King's College, from 6 to 8 o'clock on each evening the Society meets. In the Radcliffe Library at Oxford is placed one of Powell and Lealand's large microscopes complete, including a  $\frac{1}{50}$ , which may be used for examination under certain restrictions.

I should advise those who wish for a microscope as perfect as can be made in the present day, to look at the beautiful microscopes of Powell and Lealand, Ross, and Smith and Beck. In alluding specially to these instruments, I wish it to be distinctly understood that I do not in any way disparage the work of other and less cele-

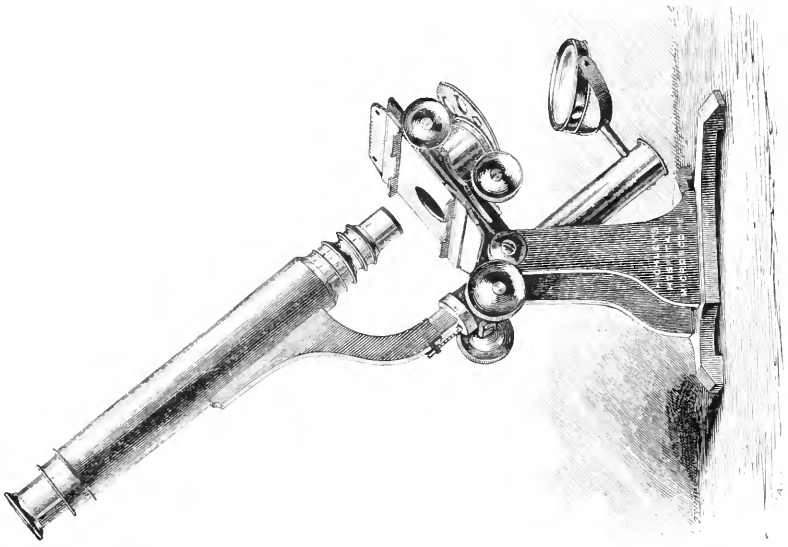
Fig. 10.



W. Palmer's student's microscope. 1864 p. 10

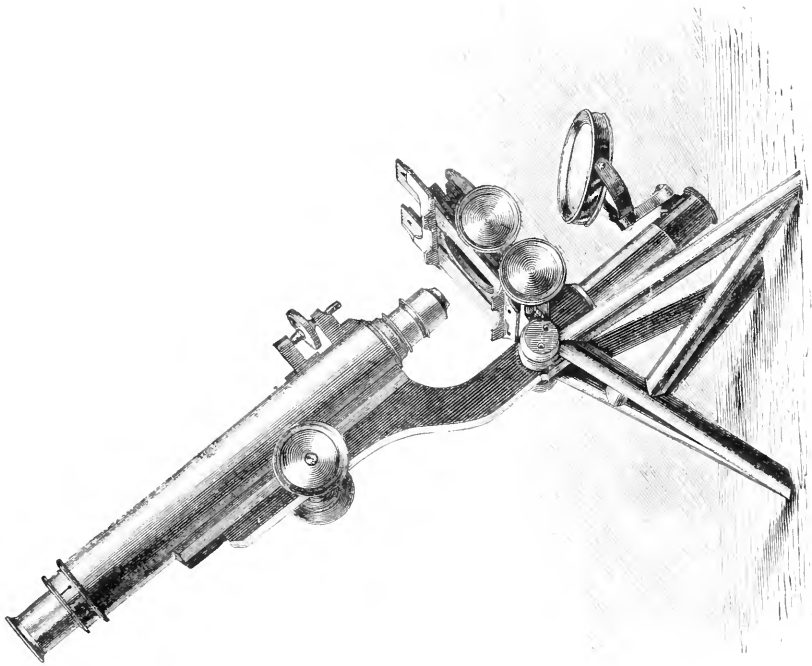


Fig. 12



Mr Highley's complete student's microscope.

Fig. 11.



Complete microscope designed by Mr. Highley.





Fig. 13.



Microscope of Messrs. Powell and Lealand, adapted for all purposes. This folds up and packs in a small hat case. p. 11



brated makers. As I have had very great experience in the use of the instruments of Messrs. Powell and Lealand, I feel it right to state that I have always found their work most excellent. These makers have done much to perfect the compound microscope, and they have produced the highest and most perfect object-glasses yet made. Messrs. Powell and Lealand's folding microscope occupies a very small space. It is represented in pl. IV.

**17. Binocular Microscopes.**—The binocular is applicable to almost every kind of microscopical research, but it is not necessary for the student, and I do not recommend those who are beginning to work at microscopical investigation generally, to provide themselves with one. The binocular should be a separate microscope altogether, or it should be possible to remove the binocular tube from the body of the microscope and substitute for it an ordinary single tube. Excellent and cheap binocular microscopes (about 10*l.*) are made by Messrs. Crouch, Messrs. Murray and Heath, Mr. Collins, pl. VI, and other makers. (*See* the list of makers at end of the volume.) Mr. Collins' binocular, which costs only twelve guineas, is represented in pl. VI.

M. Nacet's instrument and Mr. Wenham's perfected binocular are represented in pl. V, fig. 15. Mr. Wenham has succeeded in producing two or three binocular arrangements. The first plan he adopted will be understood by reference to pl. X, fig. 44; but the new method last suggested by him, and now adopted by all microscope makers in this country is shown in pl. V, fig. 16.

*New Binocular for the highest magnifying powers.*—Messrs. Powell and Lealand have recently succeeded in devising a plan by which a binocular arrangement can be adapted to the highest powers. Mr. Wenham's binocular now in ordinary use is suitable only for the examination of objects by powers magnifying less than 200 diameters. This new plan is adapted only for the higher powers, and may be used with the  $\frac{1}{50}$ .

The prisms employed are represented in pl. V, fig. 18. They are placed above the object-glasses. Of the total number of rays which have passed through the object-glass, the greater part are transmitted through the prism B and the straight tube of the microscope, but some suffer reflexion from its lower surface, and are received upon the reflecting surface E of the prism C in an oblique direction as shown by the dotted lines, and after emerging from the surface, enter the diagonal tube of the microscope.

The last of the two images is less intense than the first, but still it is light enough to be seen very clearly. The two images thus formed are exactly similar, and the two pictures appear to the

observer as one, and in relief. There is, however, no true *stereoscopic* image, for the one picture seems to be in every respect, save in intensity of illumination, the counterpart of the other.

I have examined many objects by the arrangement of Messrs. Powell and Lealand, and find that it works exceedingly well in practice, and is less fatiguing than the monocular plan, and I can recommend it to those who work with very high powers.

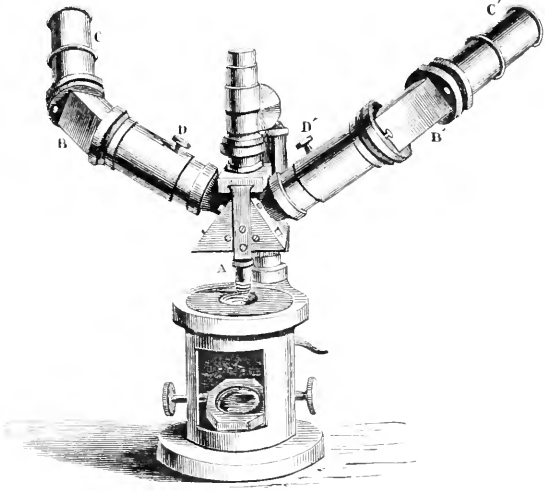
Modifications of the principle adopted by Messrs. Powell and Lealand in their binocular for high powers, have been suggested by Mr. Wenham, with the view of utilising some of the light lost in their system, but I have not had an opportunity of carefully comparing the working of Mr. Wenham's prisms with those of Powell and Lealand. From Mr. Wenham's description there appears to be some difficulty in obtaining perfectly satisfactory results. "The two prisms need not be pressed into contact—if so, Newton's rings are formed; they may be set a visible distance asunder, but great care is needed in adjusting the small prism so as to get both reflections combined, otherwise a blurred image will be seen in the slanting body." Mr. Wenham, however, assures me that the results are highly satisfactory if the instrument is properly made according to the directions he has given.

*New binocular microscope.*—More recently, Mr. Tolles, of Canastota, New York, has adapted a binocular eye-piece to the ordinary single body. This gives a large field well illuminated, and seems to perform well with low and medium magnifying powers. Professor H. L. Smith, in a note to Dr. Maddox, to whom I am indebted for the following observations, says he has even used it with the  $\frac{1}{2}$  and  $\frac{1}{6}$  objectives.

It is constructed thus:—an adjustable shallow achromatic erector or eye-piece slides in a setting that fits the tube of the single body microscope. By this an image is formed at the eye-glass end. This image then passes through the flat surface of an equilateral prism placed over the eye-lens, and by it is bisected, one half being refracted towards the right, the other half to the left. After these rays have emerged from the prism, they pass into prisms of the form used by M. Nacet in his binocular microscope (and suggested for use here by Professor Smith, as the rectangular prisms first employed by Mr. Tolles, did not give satisfactory results), and escape from their outer surfaces at the angle of total internal reflection. The rays are lastly transmitted through two deep eye-pieces or oculars superposed over the two prisms last described. See pl. V, fig. 17.

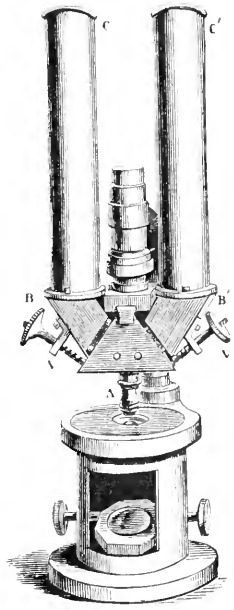
By a small pinion these prisms are adjusted for the variable distance between the eyes of different observers, and Mr. Ladd

Fig. 14.



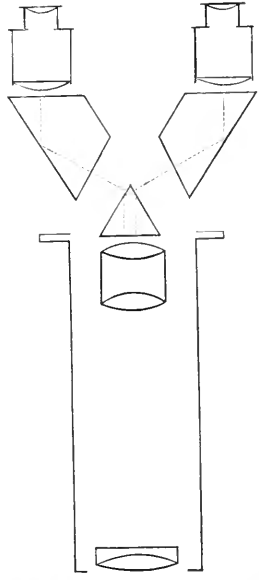
Nachet's microscope, to enable two observers to examine an object at the same time.

Fig. 15.



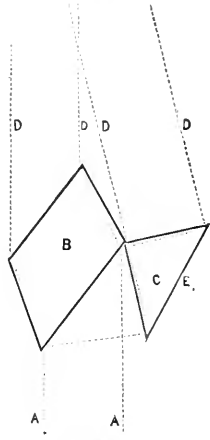
Nachet's binocular microscope. p. 11.  
See also Fig. 45 Plate X.

Fig. 17.



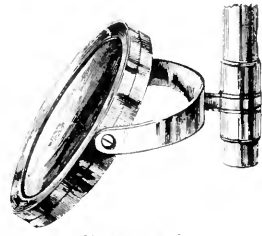
The arrangement of the prisms and lenses in Tolles's binocular eyepiece, made by Ladd. p. 12.

Fig. 18.



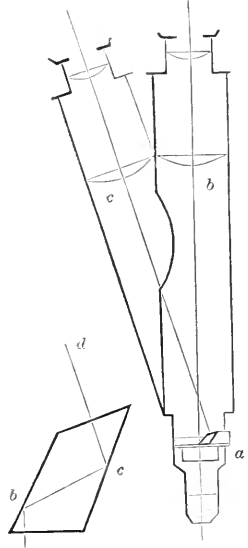
Prisms in Powell & Lealand's binocular arrangement for the highest powers. AA rays of light proceeding from object glass. B parallel piece of glass. C triangular prism. DDDD emergent rays. p. 11.

Fig. 19.



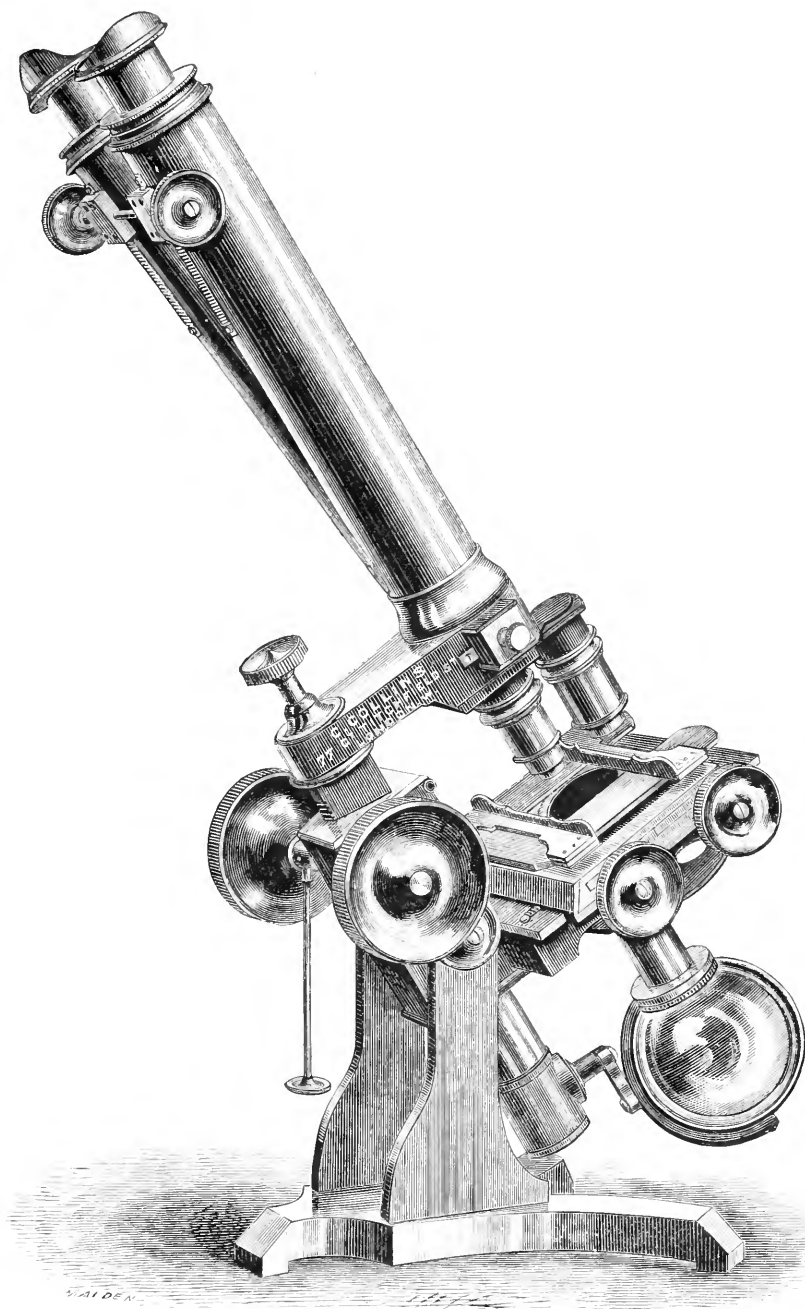
Magnifying glass.

Fig. 16.



Binocular microscope as recently arranged by John Wenham, and now generally adopted. p. 11.





Collins' binocular microscope. p. 11.

(To follow Plate V.)





has much improved and simplified that adjustment by the use of a circular disc with two eccentric slots, which entirely supersedes the rack and pinion. The shallow eye-piece, or erector, is made to slide in the eye-piece tube for the purpose of varying the distance between the eye-lens and the prism placed over it, according to the power of the objective in use.

In this new binocular we have a modification of the plan first adopted by M. Nacet, which promises, however, to be far more successful than that was. Mr. Ladd has undertaken the manufacture of this form of binocular apparatus in England.

**18. Travelling Microscopes.—Mr. Warington's Arrangement.**—

For travelling, and especially for sea-side work, it will be convenient to be provided with a microscope which can be packed in a smaller compass than the instruments already described. Mr. Warington, some time since, designed a very simple microscope for travelling purposes. The stand consists of two flat pieces of oak, fitted at right angles to each other by means of pegs. The stage is inserted into the longer one, to the top of which the body of the microscope is adapted by means of a clamp. The horizontal bar carrying the body can be moved backwards and forwards through a tube arranged to receive it. This instrument can be placed in an upright or inclined position, and by means of the clamp the body can be attached to a table, so that living objects in upright glasses can be subjected to examination. In its present form, however, the instrument is not so steady as could be wished. Several improved forms of instrument arranged according to the same principle have been suggested.

**19. Travelling, Dissecting, and Vivarium Microscope.**—Another simple form of travelling microscope is described by me in the fourth volume of the Transactions of the Microscopical Society, page 13. This instrument was made entirely of tubes, and was very steady. It could be used as a microscope for dissecting, for looking at objects in a vivarium, and for all ordinary purposes. Focussing was effected very rapidly by means of a knee lever, which was kindly made for me by Mr. Becker, instead of a screw. The arrangement has, however, been superseded by cheaper instruments.

Mr. Highly has suggested a very cheap form of travelling microscope which is also strong and useful. This is described in the Microscopical Journal, vol. iv, page 278. A very ingenious little microscope, which packs in a small leather case, has more recently been introduced by Mr. Baker, of Holborn. The body of the last two instruments can be readily adapted to the tube carrying the stage of the microscope next to be described. Mr. King, Naturalist, of the Portland Road, has devised a most convenient microscope for

examining living objects in vivaria. It is fixed to the glass of the vivarium by means of a pneumatic arrangement. It costs three guineas. This is made by Mr. Collins, of Titchfield Street.

**20. Clinical, Pocket, Travelling, and Class Microscope.**—Under this head I propose to describe an instrument devised by me some years since which I have found very useful for ordinary observation, in the field, and also for medical work, and it has been employed with great success for class demonstration.

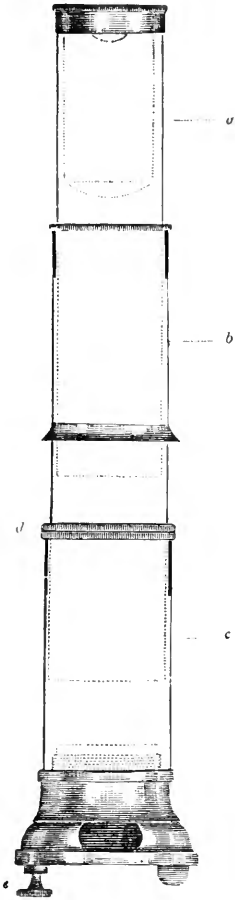
*The Microscope.*—Like some other instruments which have from time to time been proposed, this microscope is composed of draw-tubes like a telescope; but the arrangement of the stage, and the plan adopted for moving the slide when different parts of the object are submitted to examination, differ entirely, as far as I am aware, from those hitherto proposed. The instrument consists of three tubes, *a*, *b*, *c*, fig. 21, plate VII; *a* carries the eye-piece, is four and a-half inches long, and slides in *b*, which is of the same length, but only slides up to its centre in the outer tube *c*. Tube *b* carries the object-glass. The tube *c* can be fixed by aid of a screw ring *d*, at any height, according to the focal length of the object-glass. This arrangement prevents the object-glass from being forced through the preparation by careless focussing. At the lower part of the body is an aperture for throwing the light on opaque objects. The preparation is kept in contact with the flat surface below by a spring, which allows the requisite movements to be made with the hand, figs. 22, 23.

That part of the object which it is desired to examine can be easily placed opposite the object-glass if the instrument is inverted. The proper focus is obtained by a screwing movement of the tube *b*; and if it be desired to examine any other parts of the object, this is easily effected by moving the slide with one hand, while the instrument is firmly grasped with the other. Delicate focussing is effected by drawing the tube *a* up and down. By this movement the distance between the eye-piece and object-glass is altered.

Any object-glass may be used with this instrument. I have adapted various powers, from a *three-inch*, magnifying *fifteen diameters*, to a *twelfth*, magnifying *seven hundred diameters*, and I feel sure that even higher powers may be used.

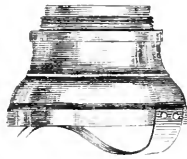
In the examination of *transparent objects*, p. 18, ordinary daylight or the direct light of a lamp may be used; or, if more convenient, the light may be reflected from a sheet of white paper, or from a small mirror inclined at the proper angle, and placed on the table. In examining objects *by reflected light*, p. 18, sufficient illumination is obtained from an ordinary wax candle placed at a short distance from

Fig. 21.



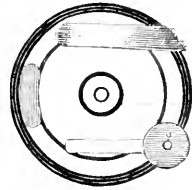
Pocket or clinical microscope.  
Half the real size p. 14.

Fig. 22.



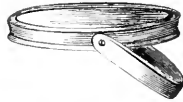
The state. Side view showing  
the position of the spring p. 15

Fig. 23.



Under surface of the body of stage  
of the pocket microscope p. 15

Fig. 24.



Mirror employed for examining  
objects by transmitted light.

Fig. 25.



Mirror to fit  
into slide

Fig. 26.



Lamp sectional  
view.

Fig. 27.



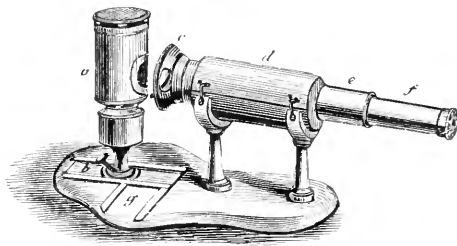
Screw with an arm for fixing  
the specimens e Fig. 21.  
p. 15

Fig. 28.



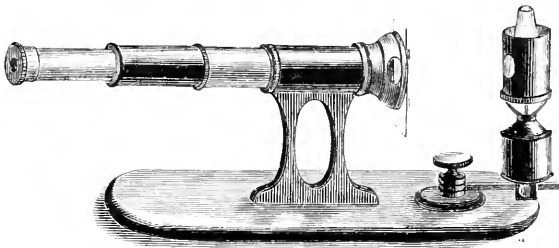
Sectional view of cell for examining  
deposits in fluid, infusoria &c.

Fig. 29.



Clinical microscope for class demonstration. p. 15.

Fig. 30.



Clinical microscope for class demonstration, with improved stand and lamp p. 15.



the aperture, just above the object. But the most beautiful effects result from the use of the Lieberkuhn, § 3c, with direct light.

The slide, as has been stated, is kept in contact with the lower part of the instrument, which I have called the stage, by a spring which is therefore made to press on the *back of the slide*. On the other side of the stage a little screw and clamp are placed so that the specimen may be fixed in any position that may be desired, figs. 21, 23, and 27.

In using this microscope, the slide with the object to be examined is placed upon the stage, the thin glass being upwards towards the object-glass, while the spring is made to press upon the *under* surface of the slide. The little screw is removed. The slide may now be moved in every position, and any particular object to be examined can readily be placed exactly under the object-glass. Tube *a* is withdrawn about two-thirds of its length. The tube *c* being firmly held with the left hand, *b* is grasped with the right, and with a screwing motion the object-glass is brought to its proper focus. The specimen having been fixed with the little clamp, and the tube fixed in its position by screwing down the ring fitted on tube *c*, the instrument may be passed round a class. This microscope seems to be well suited for field-work and especially for botanical purposes. It is not heavy, and, including the powers and an animalcule cage, will easily pack into a tube or case six and a-half inches long and two inches in diameter. I constantly use it in clinical teaching. Various deposits, specimens of sputum, &c., may be examined by the patient's bedside, and their characters demonstrated to the class. The instrument is made by Messrs. Powell and Lealand, by Mr. Highley, and other makers. Messrs. Murray and Heath have carried out some improvements in fixing the object which have been suggested by my friend Dr. Guy.

*The Stand.*—The arrangement of the stand will be at once understood by reference to fig. 29, pl. VII. The structure of the lamp is represented in fig. 26. It is an ordinary oil lamp with a diaphragm, just level with the wick, in order to cause a powerful current of air round the flame. By this means all flickering is prevented, and the instrument may be moved about without fear of the light being blown out. The diaphragm is made of a plate of mica, and the same substance is placed over the aperture in the chimney *h*. The lamp is made to slide in the grooves marked *b, g*, fig. 29, pl. VII, and it is fixed at a proper distance from the object by the screw *l*, fig. 26. At first I used oil, but for some time past I have burnt paraffin which is much cheaper and gives a far better light. When required for reflected light, the lamp is placed in the groove marked *g*, fig. 29. A

good modification of the lamp has lately been made for me by Mr. Highley which possesses some advantages over the one figured. It is probable that this may be somewhat modified. In the last arrangement the lamp is made to slide on a horizontal bar which turns on a pivot, so that the position for reflected light is easily secured, pl. VII, fig. 30. A mirror is employed by day, and slides in the same groove, or upon the same rod, as the lamp.

The mirror, achromatic condenser, polariscope, and drawing apparatus can all be readily adapted to this instrument, and it will be found convenient for photographic purposes. The microscope, without powers, can be purchased for twenty-five shillings, and with the stand it will probably cost not more than three pounds.

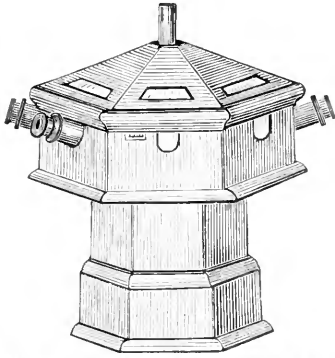
By this plan I have been able to show twelve preparations magnified from 15 to 500 diameters, to a class of upwards of a hundred during an hour's lecture. In about two minutes the specimen may be changed and another placed in its stead. The condenser, mirror, diaphragm, polariscope, &c., may also be made to slide upon a rod fixed to the lower part of the stage as shown in fig. 36, pl. VIII. I have had an arrangement adapted to this microscope which enables me to use it for demonstrating structures with still higher powers. In the instruments used at my lectures given in 1861 at the College of Physicians, I was able to use successfully all powers up to the twelfth (700 diameters), and I feel quite satisfied that the plan will succeed equally with the highest powers which have ever been made. An instrument has been made to take the  $\frac{1}{2}$ .

These hand microscopes can also be readily arranged in a line, pl. VIII, figs. 33, 34, or in a six or eight-sided frame, figs. 31, 32, in the centre of which the light, to illuminate all the objects at once, may be placed. One advantage of this arrangement for demonstrating to a class is that while every one can alter the focus to suit his vision the preparation and light are quite out of reach.

These simple tube microscopes have been modified in many ways by various makers, and some have been made so small that they may be carried in the waistcoat pocket. An instrument of this kind is made by Mr. Highley. It is four inches long and only three quarters of an inch in diameter, and is sold for a guinea. Not being provided with the stage and spring, only one spot in the field can be brought under the object glass, but it is only intended for low magnifying powers which give a large field, pl. VIII, fig. 37.

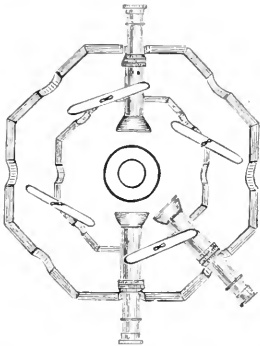
**21. Dissecting Microscope.**—In figs. 38, 39, 40, pl. IX, is shown the form of dissecting microscope devised and recommended by the late Professor Quekett. Fig. 40 shows the internal arrangement and the manner in which the mirror, lenses, and lens-

Fig. 31.



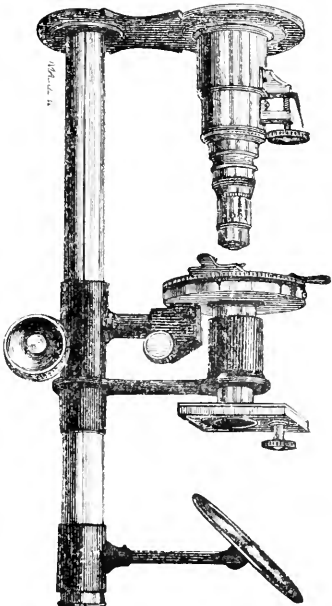
Hexagonal box for holding eight microscopes, illuminated by one lamp in the centre. p. 10.

Fig. 32.



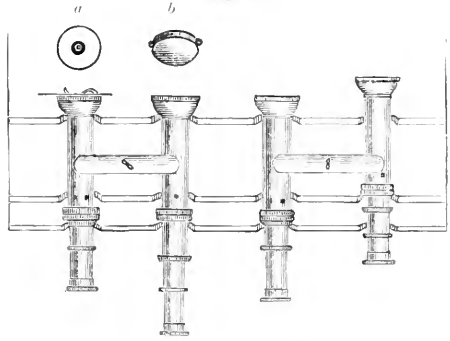
Position of Fig. 31, showing relative positions of microscope and lamp made of zinc. &c. p. 10.

Fig. 35.



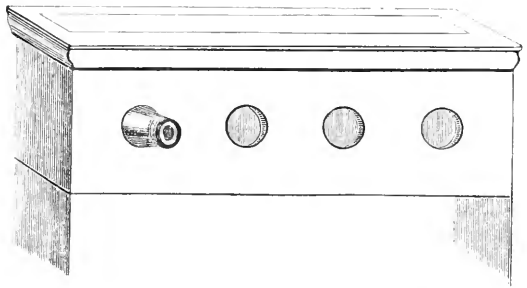
Simple arrangement for adapting stand and mirror to body for photographic work. After G. Huxley.

Fig. 33.



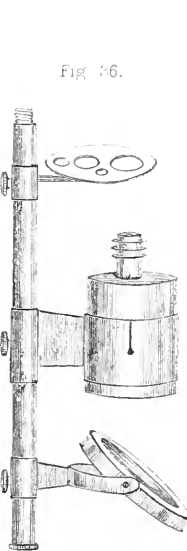
Another arrangement for mounting four of the pocket microscopes. p. 10.

Fig. 34.



Front view of the arrangement represented in Fig. 33. p. 10.

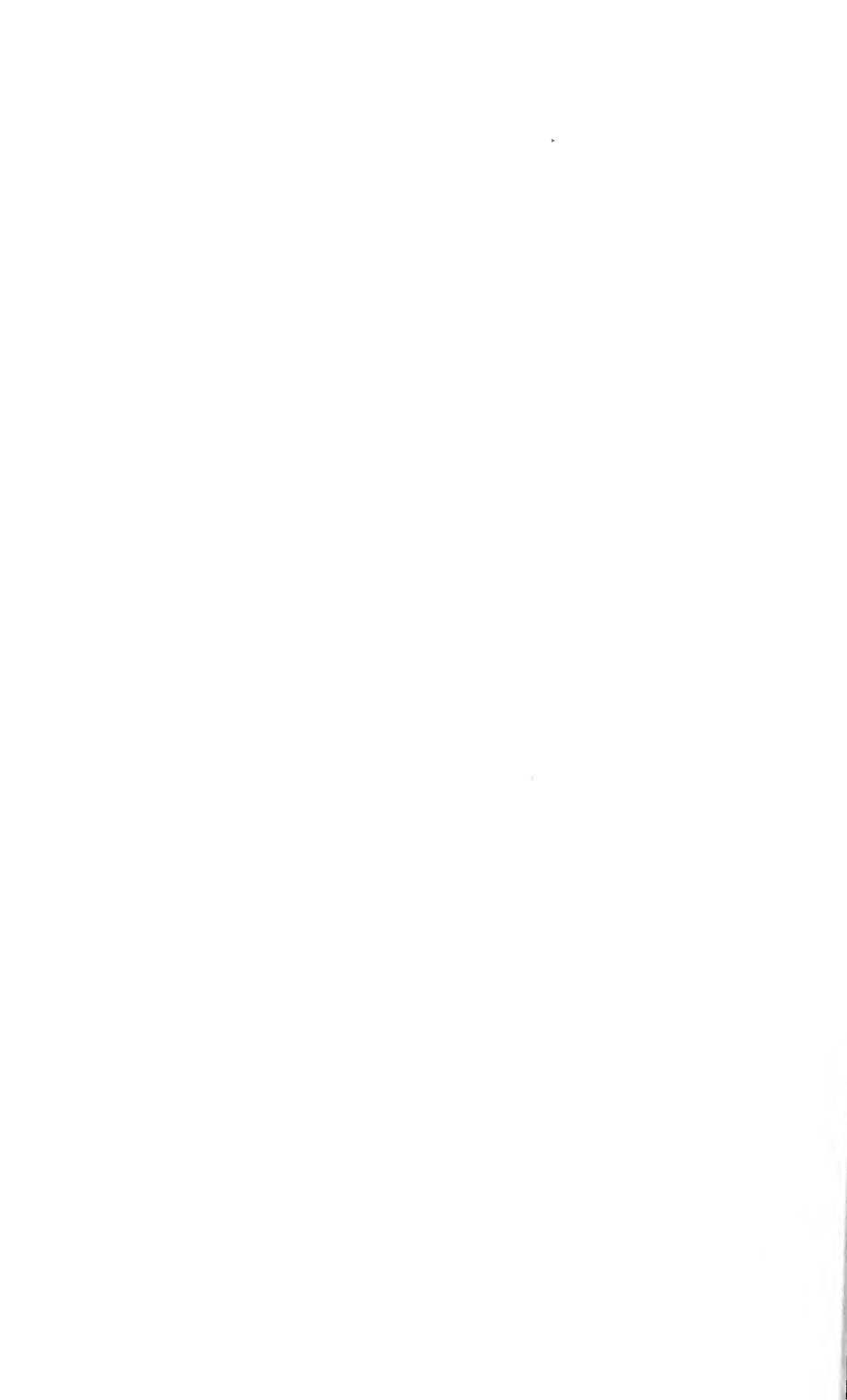
Fig. 36.



The arrangement by which diaphragm, mirror, and condenser may be adapted to the pocket microscope. p. 10.



Wasteful pocket microscope four inches long. Made by Mr. Biddle. p. 10.





holders are packed away. The instrument is furnished with three lenses, and is to be purchased at a moderate price.

*Latson's Dissecting Binocular Microscope*, as made by Collins, pl. IX, fig. 41, though only constructed for slight magnifying power is exceedingly compact and enables the observer to use both eyes. It is furnished with two sets of stereoscopic lenticular prisms, dissecting instruments, &c. It costs two guineas.

**22. Apparatus necessary for the Student.**—Every student's microscope should be provided with a *neutral tint glass reflector for drawing and measuring objects*, a *diaphragm*, to the under part of which is fitted a tube to receive an *achromatic condenser* or *polarizing apparatus*: a *bull's eye condenser*, one *shallow eye-piece*, and two powers—a *low one, magnifying from 20 to 40 diameters*, and a *quarter*, or a *four-tenths of an inch which magnifies 180 diameters*, a *stage micrometer*, § 60, a *Maltwood's finder*, or the *plan adopted by Mr. Baker*, § 68, and an *animalcule cage*, § 134.

These instruments should be conveniently packed in the case with the microscope. The polarizing apparatus and the achromatic condenser (*see* page 25) are not absolutely necessary for a beginner and can be purchased afterwards. The cost of the microscope without these last instruments, but including the other apparatus mentioned, in a well-made case, need not be more than six pounds; and if the microscope be mounted on a cast-iron foot instead of a brass one, it may be obtained for about a pound less, without its practical utility being in any way impaired.

The great number of different microscopes and the excellent workmanship employed in their construction render it a difficult as well as a delicate task for a teacher to recommend any special one to his pupils. Although many of the instruments which I have used are exceedingly good, I doubt not that there are others, which I have never had the opportunity of testing, as good in every respect. The names and addresses of the principal English and Foreign microscope makers will be found at the end of this volume.

#### OF ILLUMINATING OBJECTS.

##### **23. Reflected Light, Transmitted Light, and Polarised Light.**—

If the internal structure as well as the external surface of an object be examined in the microscope, the observer will form an idea of its nature very different to that which he would have arrived at if he

had regarded one set of characters only. And by employing polarised light peculiarities in the structure of an object may be discovered which cannot be perceived when it is examined by ordinary light.

I must, therefore, draw the student's attention to the three following methods of directing the light upon objects to be submitted to microscopical examination.

1. *Reflected light*.—In the examination of an object by reflected light, ordinary diffused daylight may be allowed to fall upon it, or light may be received upon a metallic reflector, or be refracted through a prism placed at the proper angle and thus made to impinge upon the surface of the object. The intensity of the illumination may be increased by employing a concave mirror or a bull's-eye condenser, § 27.

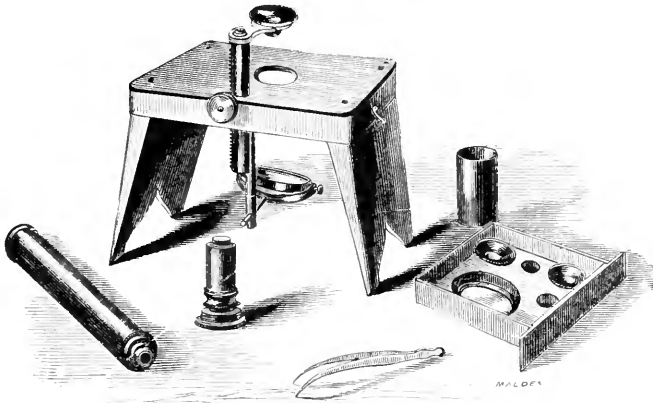
By this mode of examination we gain information concerning the peculiarities of the surface only, as in looking at objects under ordinary circumstances. The surface of a perfectly transparent object may be examined by reflected light, §§ 30, 32.

2. *Transmitted light* passes through the object which is examined, which must, therefore, be transparent or capable of being rendered so by some special method of preparation, § 140.

In this way any peculiarities of internal structure are discerned. Transmitted light may be made to pass from the source of illumination direct through the object, or the rays of light may first be received by a mirror or prism and then transmitted in a straight or oblique direction through the preparation.

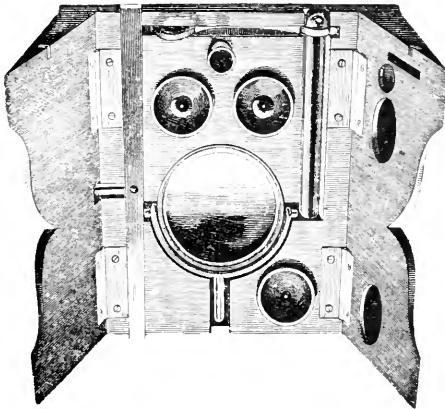
3. *Polarised Light*.—The light is polarised by being made to traverse certain crystalline substances which possess the polarising property before it is transmitted through the object. A crystal of that form of carbonate of lime, known as Iceland or rhomboidal spar, tourmaline, or iodo-quinine, is the most convenient for this purpose. The first is generally used under the name of Nicol's prism which is made by dividing a crystal of Iceland spar obliquely, and then carefully cementing the two portions together with Canada balsam. In this way one of the two images produced by this double refracting crystal is refracted out of the field of vision while the polarising property is not in any way affected. Dr. Herepath has sent me two beautiful crystals of the iodo-quinine or herapathite which he discovered some years ago. The crystals are mounted between two pieces of thin glass and work very satisfactorily. One of the crystals above referred to is fitted beneath the stage of the microscope. This is called the *polariser*. Another termed the *analyser* is inserted in the tube of the microscope or is placed above the eye-

Fig. 38.



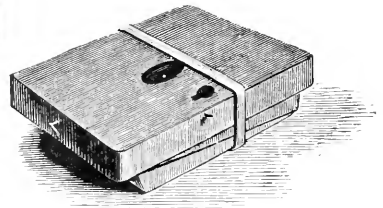
Professor Quekett's dissecting microscope with apparatus. p. 16

Fig. 39.



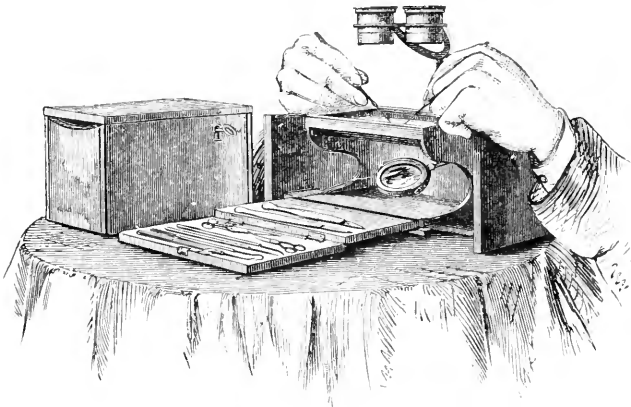
Professor Quekett's dissecting microscope. Mode of packing the different pieces of apparatus. p. 17

Fig. 40.



Professor Quekett's dissecting microscope. The instrument folded up for traveling. p. 19

Fig. 41.



Dr. Lawson's dissecting microscope, made by Collins. p. 27



piece, pl. XIII, figs. 57 and 58. Either the *analyser* or the *polariser* should be so arranged that it may be made to rotate.

By polarised light the internal structure of various transparent objects can be rendered evident in a very beautiful manner, but for ordinary microscopical work this method of observation is of little use, and I think the advantage of polarised light in general microscopical enquiries has been much overrated. In examining objects by polarised light beautiful effects may be obtained by interposing between the polariser and the object thin plates of certain crystalline substances which should be so arranged as to be capable of revolving. The play of colours which may be produced in this way by the aid of selenite is in the case of many objects very beautiful. Plates of different degrees of thickness, each giving a different colour, may be obtained of the opticians.

#### *Sources of Illumination.*

Ordinary daylight or sunlight reflected from a white cloud affords the best illumination, but the light of a candle, gas, or good lamp answers exceedingly well if certain precautions be taken. Daylight is usually reflected from the mirror. In the examination of transparent objects the microscope is arranged as in pl. X, fig. 42, and the light is usually reflected by the mirror. Sunlight is only employed under very special circumstances, as for examining objects by coloured media, when an intense light is required, or for the purpose of taking photographs of microscopic objects. See Part IV on Photography.

**24. Artificial Illumination.**—It has been said with truth that microscopical work should be undertaken only by day, since the most perfect artificial light which can be obtained is far inferior to daylight for delicate observation, while it strains the eyes very much more. But unfortunately it happens that in this country, especially in our large cities, during a great part of the year, our daylight is not very suitable for microscopical investigation, while some of us, in consequence of being occupied in work of perhaps a very different kind by day, are compelled to work principally or entirely by night. It is therefore a matter of the greatest importance that we should be provided with a good kind of artificial illumination.

#### *Lamps.*

From time to time various microscope lamps have been proposed. The small *camphine lamp* brought out many years ago by

Messrs. Smith and Beck, and since modified for paraffine, represented in pl. XI, fig. 46, gives a white light, and produces very little heat. Of *oil lamps* there are several which serve for microscopical examination. The *German Argand lamp*, lately imported into this country by Mr. Pillischer, is a good microscope lamp, and so also is the ordinary *French moderator*, especially if provided with a blue or neutral tint glass chimney, and a shade. But these lamps, and indeed gas itself, yield to paraffine and belmontine which give an exceedingly steady and white light with very little heat.

**25. Paraffine Lamps.**—For some years past I have been in the habit of using one of the common little paraffine lamps, termed night lamps, with a small *round* wick, which may be bought for 1s. 6d. pl. XI, fig. 47. This gives a very white light, and is most convenient, as well as economical. A pale blue glass chimney improves the quality of the light, and a shade protects the eyes from the general glare. I use this lamp with the fiftieth, and find that it works admirably.

Mr. Collins sells an excellent paraffine lamp under the name of the "Bockett Lamp," which is provided with an adjustable silvered reflector, a bull's eye condenser, and a blue glass chimney. One of these has been fitted up with a round wick, like the little lamp above referred to. I do not think anything more simple or convenient for microscopical purposes can be obtained, fig. 48, pl. XI.

**26. Gas Lamps.**—For those who prefer gas I recommend the gas lamp of Mr. Highley, which is provided with a flat brass plate and a water bath, instruments of great use in microscopical investigation, pl. XI, fig. 49. The light is made to pass through an opening in a diaphragm, so that the eyes are quite protected from the diffused light. A very pleasant light is produced, as in other lamps, by causing the rays to be transmitted through a blue chimney glass and a flat piece of neutral tint glass. The objection to this lamp is its great heating power.

The eye not observing should always be kept open, but protected from the direct glare of the microscope lamp. For this purpose a shade made of black paper may be fitted to the body of the instrument at a convenient distance below the eye-piece.

*Of examining the Surface of Objects by Reflected Light.*

Ordinary diffused daylight or lamplight may be used for this purpose, but this mode of illuminating opaque objects will seldom give satisfactory results. Unless sunlight or some other very power-

Fig. 41.

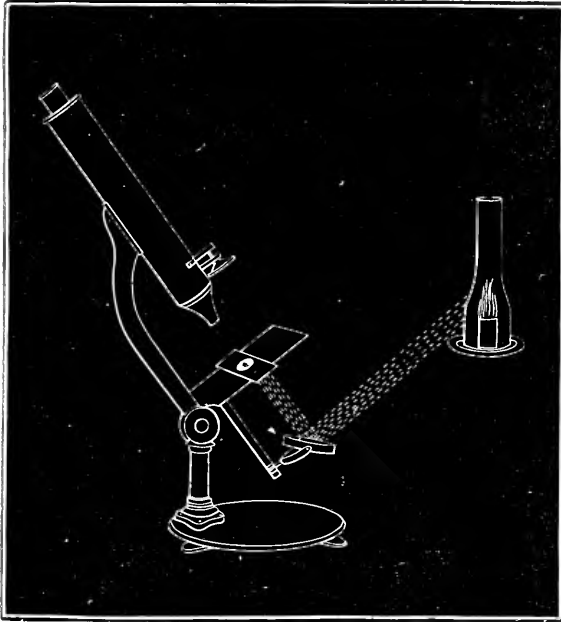
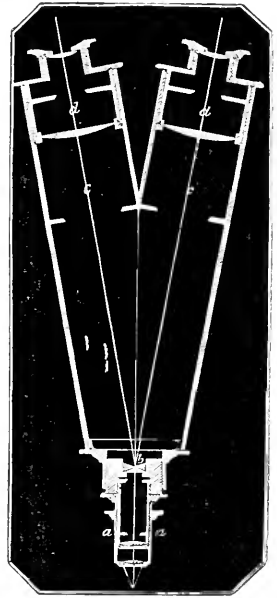


Diagram to show the arrangement of converging lenses by transmission of light.

Fig. 42.



Mr. Wrenham's original arrangement of the binocular microscope. p. 10.

Fig. 43.

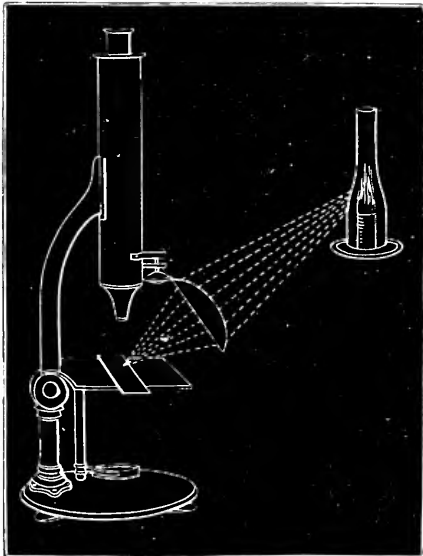
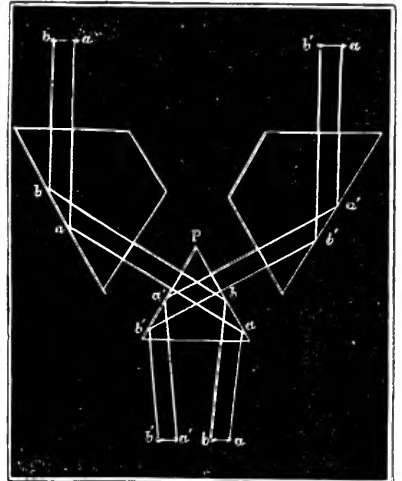


Diagram to illustrate the arrangement of lenses and light rays reflected at right angles.

Fig. 45.



Arrangement of prisms in Nohel's binocular microscope. p. 11.





ful light be employed, it is necessary to concentrate the rays upon the surface of the object placed in the focus of the object-glass by the aid of one of the following instruments.

**27. Bull's Eye Condenser.**—This instrument is provided with all microscopes, and needs no description. Different modes of mounting the plano-convex lens are represented in figs. 51 and 52, pl. XI, and the position of the microscope, condenser, and light in fig. 43, pl. X.

**28. Metallic Reflector.**—A concave metallic reflector may also be used to bring the rays of light from a lamp to a focus on the object. This instrument is fitted to the side of the microscope. I do not, however, think it possesses any advantages over the bull's eye condenser.

**29. Beck's Parabolic Reflector,** pl. XI, fig. 50.—This instrument is made to fit on and rotate round the object-glass; it answers admirably for condensing the light on the surface of objects, and by throwing the rays in any particular direction across the surface enables the observer, by the assistance also of the shadows, to determine the nature of irregularities upon some objects in a very satisfactory manner. By the adaptation of a little reflector, arranged as represented in fig. 50, pl. XI, Mr. Sorby gained great advantage in the examination of the fractured surfaces of iron and steel. *See* Microscopical Journal, Oct. 1865, p. 117.

**30. Lieburkuhn.**—The rays of light reflected from the mirror and passing round the *circumference of the object* placed in the field impinge upon a *concave annular reflector* or *Lieberkuhn* adapted to the object-glass, from which the rays are reflected downwards, and brought to a focus upon the surface of the object itself, pl. XII, fig. 53.

If a transparent object is to be examined by reflected light, a piece of black paper, rather larger than the aperture of the object-glass, should be placed behind it to prevent the passage of light through it, or one of the stops, fig. 53 *e*, supplied with some instruments may be inserted in its place beneath the stage. The stops, however, are not furnished with many of the modern microscopes.

**31. Arrangement for examining Opaque Objects with very High Powers.**—Prof. H. Lawrence Smith, of Kenyon College, Gambia, Ohio, U.S., has introduced a plan by which the object-glass is made its own illuminator. The rays of light are admitted at the side of the lower part of the tube of the body, received upon a small silvered mirror set at the proper angle, and cutting off a portion of the aperture, by it thrown down through the objective to the object, and returned through the object-glass and aperture of the mirror to the eye-piece.

Messrs. Powell and Lealand substituted for the silvered mirror a

piece of thin plate glass ( $\frac{1}{16}$  of an inch thick) placed at an angle of 45 degs. In this way loss of light was avoided, as the magnified image was seen *through* the glass.

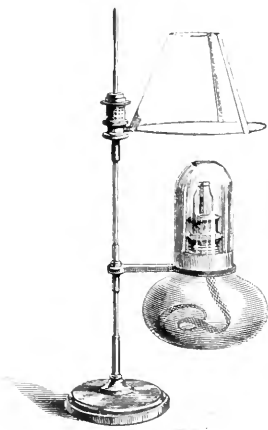
The late Mr. R. Beck about the same time adopted a similar plan, using a circular piece of ordinary thin covering glass, which was arranged so that the angle of inclination could be altered if required. I learn from Dr. Maddox that Prof. Smith still gives the preference to his own arrangement.

These new methods of illumination which are improvements upon that devised five years since by Mr. Hewitt, but on the same principle, are valuable for observations upon the diatomaceæ. For a full description the reader is referred to Professor Smith's paper in Silliman's Journal for September, 1865; Mr. R. Beck's paper in the Microscopical Journal for April, 1866; and the remarks made by Mr. Wenham, Mr. Slack, Mr. Lobb, and others in the same number.

Mr. Dancer has proposed another modification of the above plan. A little speculum, only one-sixth of an inch in diameter, is introduced through a lateral aperture two inches and a half above the top of the object-glass, and placed at a proper angle to reflect the rays downwards (Popular Science Review, April, 1866, p. 249).

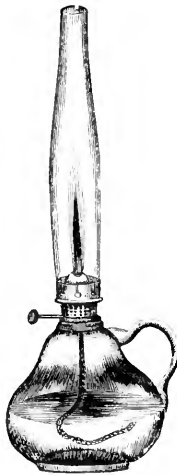
**32. Dark-ground Illumination.**—In this place I must allude cursorily to a mode of illumination which has been much in repute of late years, and which is very advantageous for demonstrating some structures. I refer to *dark-ground illumination*, in which the object appears in relief upon a black ground. In this mode of illumination, which is particularly applicable to investigations upon some very minute organisms, such as the diatomaceæ, the direct rays are prevented from penetrating the specimen, and passing through the object-glass, but the preparation is highly illuminated upon all sides by light made to impinge upon it in a very oblique direction. Thus the object is thoroughly illuminated upon every part of its surface, but the ground on which it lies appears perfectly dark. There are several methods by which this result may be obtained. One very simple little instrument is termed a *spot-glass*, and consists of a plano-convex lens, the convexity being so great that rays of light passing through it converge with a great degree of obliquity, and are brought to a focus at a short distance above the flat surface of the lens, in the centre of which is placed a small circular piece of black paper in order to prevent the passage of any direct rays of light. The lens is fixed in a brass tube made to slide up and down, so that it may be adjusted at the proper distance below the object. The spot-glass may be purchased of the instrument makers for about 7s. 6d.

Fig. 46.



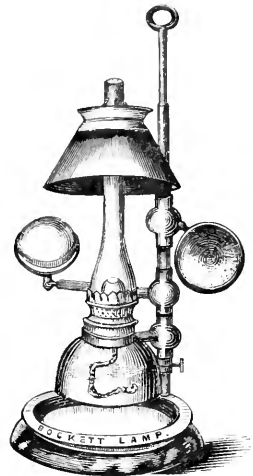
Lamp of Messrs. Smith, and lock for complete illumination. p. 20.

Fig. 47.



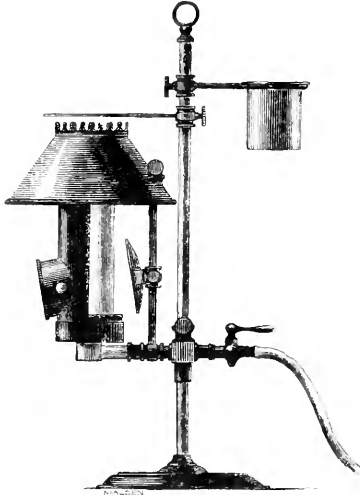
Simple paraffine lamp with a wick. p. 20.

Fig. 48.



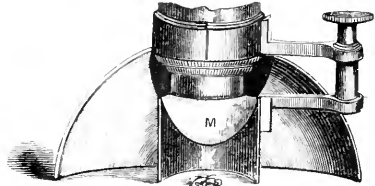
rocket lamp, made by Collins with round wick. p. 20.

Fig. 49.



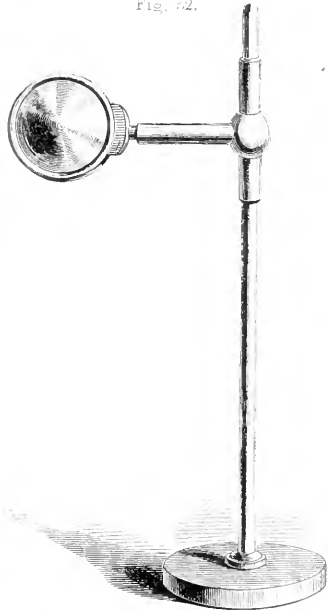
Gas microscope lamp, with water bath, &c. arranged by Mr. Huxley. p. 20.

Fig. 50.



Lock's paraffine reflector, with 30° spheroidal condenser. p. 21.

Fig. 52.



Collins' condenser apparatus. p. 21.

Fig. 51.



Coll's cylindrical condenser for students' microscope. p. 21.



**33. The Parabolic Reflector** of Mr. Wenham, Mr. Shadbolt's *annular condenser*, and the *parabolic illuminator* of Messrs. Smith and Beck are beautiful instruments for effecting the same purpose in a more efficient manner, pl. XII, fig. 55. Another excellent plan has lately been devised by Mr. Wenham, the simplicity of which recommends it strongly to our attention. A small triangular prism is placed beneath the object, so that one of its plane surfaces is in contact with the under surface of the slide carrying the object. The light is refracted so highly that none passes directly through the object, but, being thrown at the proper angle upon the under surface of the thin glass which covers it, is entirely reflected from thence upon the object itself, which is thus highly illuminated.

*Of examining the Internal Structure of Objects by Transmitted Light.*

**34. Transmitted Light.**—In discussing the mode of illuminating objects by transmitted light, I must briefly draw attention to two or three beautiful instruments for condensing the light upon the object. The microscope in pl. X, fig. 42, is arranged in the ordinary position for examining transparent objects. The light may be received upon the plane or concave mirror, according as a moderate or brilliant light is required; but, as a general rule, the intensity of light should not be greater than necessary to make out distinctly the structure of the object. Direct sunlight is not to be employed, and a very strong light of any kind is hurtful to the eyes. The best light during the day is to be obtained from a white cloud upon which the sun is shining.

**35. Monochromatic Illumination.**—Professor Amici seems to have been the first to have tried experiments with monochromatic light in the examination of objects in the microscope. He employed the rays of the solar spectrum, but I am not aware that any great advantages have been obtained or new facts discovered by this process. Yet it seems probable, now that we are enabled to examine objects so much more minutely than heretofore, that something may be gained by enquiries in this direction. Any ray from an ordinary prism may be caused to pass through the object or condensed upon it with the aid of the condenser. Count Castracane has since used monochromatic light for microscopical observation and for taking microscopical photographs (*Microscopical Journal*, October, 1865, p. 250), and a similar plan has also been used in America by Mr. L. W. Rutherford for the same purpose. Count Castracane used one of Dubosq's Heliostats, a rather expensive instrument, by which the whole field could be illuminated by any single ray desired, and by the move-

ment of the prism, effected by clockwork ; this ray was prevented from passing out of the field.

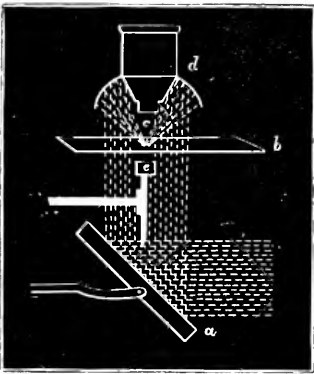
**36. The Diaphragm** has been already described in § 14. The definition of the structure of a transparent object is often found to be very much clearer when only the more direct and central rays of light from the concave mirror are allowed to pass through it. An excellent contrivance for altering the size of the aperture in the diaphragm has been recently devised by Mr. Collins, fig. 59, pl. XIII. See also § 39.

**37. Achromatic Condenser.**—The illumination of some objects examined with high powers is much improved by causing the light to pass through an achromatic condenser which may consist of an ordinary achromatic objective of half or a quarter of an inch focus, arranged in a sliding tube immediately beneath the stage. One of these instruments can be fitted to the student's microscope. Mr. Quekett has adapted a simple lever handle by means of which the right focus is readily obtained, pl. XII, fig. 54. The instrument is not an expensive one, if it be made of a French combination. I have often obtained very good illumination suitable for the examination of most tissues without using an achromatic condenser. In working with high powers, however, it is absolutely necessary.

A *Kelner's eye-piece*, as already stated, makes a most valuable achromatic condenser, and has been of the most material assistance to me in many of my recent investigations. The observer will find that by stopping off the greater part of the light passing through the condenser by placing over the upper lens a thin plate with a very small central hole, great advantage results in working with high powers. The hole may be made in a flat piece of thin brass, which is kept in its place by a very slight rim projecting about the twentieth of an inch or less above the top of the condenser. In this way apertures of different sizes may be tried without trouble. My friend Mr. B. Wills Richardson uses stops over the condenser, in which slits and holes are made of peculiar shape, and varying much in position, some allowing only a very small pencil of light to pass at the side. *Microscopical Journal*, January, 1866, p. 10.

**38. Gillett's Condenser.**—Mr. Gillett has adapted a diaphragm plate and stops to the achromatic condenser, and there is a beautiful instrument of this kind made by Mr. Ross. Messrs. Powell and Lealand have, however, improved upon it, and brought out a much smaller and more compact condenser, which is attached to their microscope. The Rev. J. B. Reade, to whom we are indebted for many improvements in this direction, has contrived a valuable hemi-

Fig. 53.



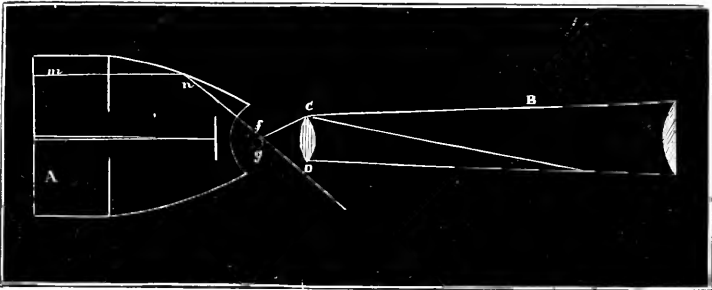
To illustrate the mode of examining an object by reflected light with the Lieberkuhn. The light reflected from the mirror *a* passes through the glass slide *b*, around the object, and impinges on the concave annular mirror *d*, by which the rays are brought to a focus and condensed upon the object placed at *c*. p. 11.

Fig. 54.



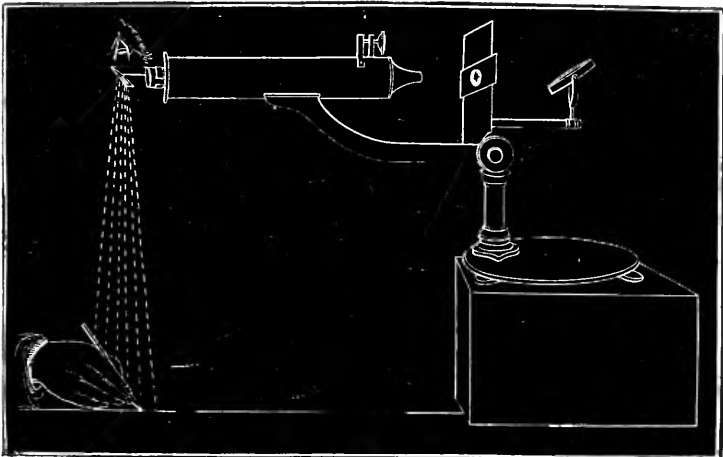
Achromatic condenser mounted with a lever. Landis. p. 11.

Fig. 55.



Parabolic illuminator, showing course of a ray of light, *m n f*, when an uncovered object, *g*, is placed in focus. p. 13.

Fig. 56.



Arrangement of microscope for drawing and measuring objects. p. 27.





spherical condenser for examining objects marked with very fine lines by oblique light. *Trans. Mic. Soc.* 1861, p. 59. The same observer has recently modified his instrument by the addition of another lens, by which arrangement he is able to obtain a ray of light of greater obliquity than is possible by ordinary methods of proceeding. *Micr. Journal*, January, 1867, p. 3.

**39. New Webster Condenser.**—Lately a form of achromatic condenser, which passes by the name of 'Webster's,' like the eye-piece used for a condenser, lets a flood of light upon the object, has been much improved by Mr. Highley, Mr. Collins, and other makers. Mr. Collins' ingenious arrangement for altering the size of the aperture of the diaphragm, instead of using the plate with holes in it, will be understood by reference to fig. 59, pl. XIII. It seems to me likely that this will supersede other plans entirely. This condenser is well adapted for working with the binocular. Mr. Collins is endeavouring to increase the angular aperture by the addition of a third lens, and render it really achromatic like Kelner's eye-piece above referred to.

Although it seemed to me desirable to refer to the above different methods of modifying the illumination of objects, it must not be supposed that the delicate instruments which have been described are essential for beginners or for ordinary observation. The student may even pursue some branches of original investigation in which high powers are not required, without employing one of them. In special enquiries, however, great advantage has resulted from the use of some of these instruments, and no one would attempt to undertake certain researches, as for instance, upon the nature of markings on diatoms or other delicate structures, without making himself familiar with the different effects resulting from their use, and he would probably soon find, that by modifying the plan which gave the most favourable results still better definition was to be obtained, or new facts were to be demonstrated.

**40. Examination of Objects.**—It is instructive for the observer to subject specimens as for example, granules of fine sand or powdered gypsum, potato starch, or arrowroot, to examination in four different ways. 1. The surface of the object may be examined by *reflected light* brought to a focus upon it by means of a bull's-eye condenser. 2. The light may be *reflected* upon it from a *Lieberkuhn*. 3. The light may be transmitted through the object after it has been reflected from the surface of the mirror. And, 4. The object may be placed under the influence of *polarised light*, with and without a selenite plate.

The conclusion arrived at with reference to the nature of the

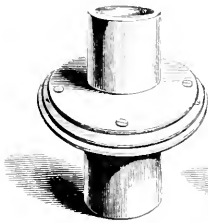
structure after having been submitted to these four modes of examination, should be contrasted with the idea which would have been formed of it if an observation had been made by one mode of illumination only. But before this can be practically carried out, it is necessary to describe how objects are to be examined in various media. The student must therefore refer to §§ 136 to 143.

#### OF DRAWING AND ENGRAVING OBJECTS.

**41. Of Drawing Objects.**—It may be truly said that no real advance in our knowledge of the minute structure of animal or vegetable tissues, can be communicated to others, unless accurate drawings are made, for it is almost hopeless for an observer to attempt to describe what he sees in words, and such descriptions, however careful they may be, scarcely admit of comparison with those of other persons. On the other hand, a truthful drawing of what a man has seen recently, may be compared with drawings which may be made a hundred years hence, and although the means of observation will be far more perfect than they are at present, such comparisons may be useful in many ways, and especially in preventing erroneous conclusions. By description alone ingenious persons who take the pains may so express themselves as to render it very doubtful what their opinion really is, but if they can only be persuaded to make a drawing, there can be no doubt concerning the exact nature of their view. I think that an honest enquirer cannot be of greater use in his time than by making good drawings of what he has seen, and we may feel sure that those who follow us will respect our drawings, if honest copies of nature, although very little of what is now written will be read some years hence, when the whole aspect of our department of science shall be changed.

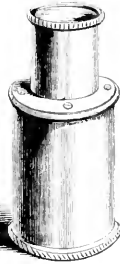
In delineating an object magnified by the microscope it is important to copy it correctly, both as regards the relative position of the several parts to one another, and also with respect to size. To copy the size exactly will be found extremely difficult by the eye alone, but there are several ways of proceeding by which accuracy may be ensured. Some of these I shall now briefly describe. The simplest method is to place the paper upon the same level as the stage upon which the object is situated. If we now look steadily at the object with one eye, while the other is employed to govern the movements of the pencil, the object appearing to be thrown as it were, upon the paper, its outline may be very readily traced. By a little practice the relative size of objects may be insured in this manner, but it is troublesome and difficult to keep the image of the object perfectly still.

Fig. 57.



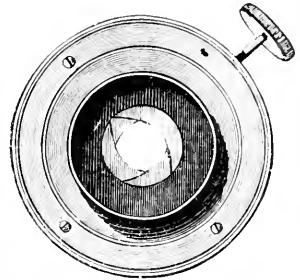
Magnifier, placed beneath the object. p. 18.

Fig. 58.



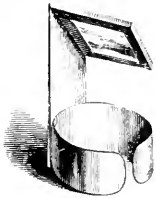
Analyzer placed above the object. p. 18.

Fig. 59.



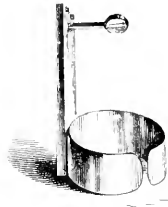
Slits for circularly polarized light. p. 18.

Fig. 60.



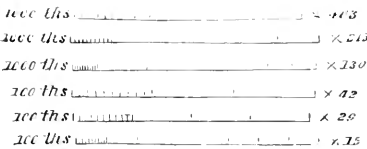
Central tint Glass reflector for drawing. p. 27.

Fig. 61.



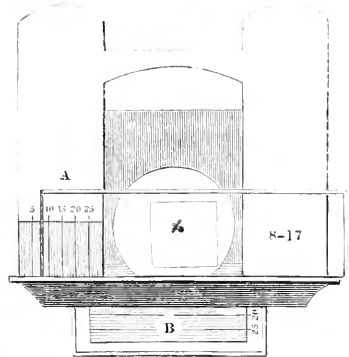
Steel disk. p. 27.

Fig. 62.



Scales hundredths and thousandths magnified in different degrees. p. 27.

Fig. 63.



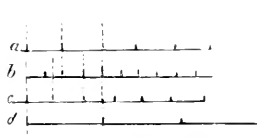
Simple microscope designed by J. W. Wright. p. 27.

Fig. 64.

11	12	13	14	15
24	24	24	24	24
11	12	13	14	15
25	25	25	25	25
11	12	13	14	15
26	26	26	26	26
11	12	13	14	15
27	27	27	27	27

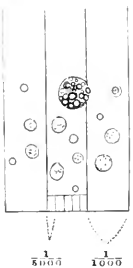
A portion of Maltwood's Ladder, as seen in the microscope. p. 27.

Fig. 65.



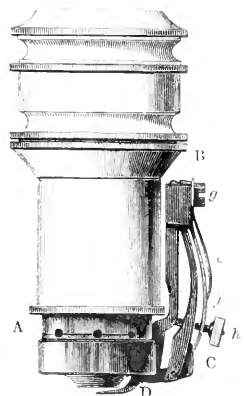
Mode of ascertaining the magnified power of an object-glass.  $a$ , fourths of an inch  $\times 40$ .  $b$ , eighths of an inch  $\times 80$ .  $c$ , sixteenths of an inch  $\times 160$ .  $d$ , thirtyseconds of an inch  $\times 320$ . Each magnified length of an inch covers two-tenths, or one-fifth of an inch, therefore the glass magnifies 200 times, for  $\frac{1}{1000} \times 200 = \frac{2}{10}$ , or  $\frac{1}{5}$  of an inch. Each fortieth of an inch covers four-tenths of an inch, therefore the glass magnifies 40 times, for  $\frac{1}{100} \times 40 = \frac{4}{10}$ . p. 27.

Fig. 66.



Lines separated by  $\frac{1}{1000}$  of an inch magnified 250 diameters, with objects magnified in the same degree. p. 27.

Fig. 67.



Instrument for scratching a circular line on the thin glass to show the position of an object. p. 41.



**42. Camera Lucida.**—The camera lucida has been applied to take microscopical drawings, and has been found to succeed admirably. The object appears to be thrown down upon the paper, and with a little practice the observer may trace the lines with great accuracy. If there should be any blueness round the edge of the field, the distance between the prism and the eye-glass should be increased.

**43. Steel Disk.**—If a little steel disk be placed at an angle of 45 degs. with the eye-glass, it will receive the magnified image of the object and reflect it upwards upon the retina of the observer. The disk being smaller than the aperture of the pupil, the pencil can at the same time be seen very well as it traces the image apparently thrown down upon the paper beneath. The steel disk is represented in pl. XIII, fig. 61.

**44. Neutral Tint Glass Reflector.**—The simplest and cheapest reflector for microscopical drawing, consists of a small piece of plate-glass slightly coloured, but not so dark as to prevent an object being seen through it perfectly. This is also arranged at an angle of 45 degs. with the eye-glass; by it the draughtsman can very easily follow the outlines with his pencil upon the paper. This instrument is represented in pl. XIII, fig. 60.

In order to use these instruments, the microscope is arranged horizontally, and the paper placed on the table, as shown in pl. XII, fig. 56.

**45. Arranging Light.**—It is important, however, in using these instruments, to arrange the light carefully. The image should not be illuminated too intensely, and the paper upon which the drawing is made should not be too much in the shade, or the point of the pencil will not be seen distinctly. Experiment can alone decide the relative intensity of the light upon the object and upon the paper, but with a little practice the proper amount of illumination will be discovered. The object appears to be thrown upon the paper, and its outline is very readily traced. If it is to be drawn smaller, it is only necessary to place the paper upon a stand closer to the reflector. If, on the other hand, a large *diagram* is required, the distance must be increased. By placing the diagram paper upon the floor, the object can be readily traced with a long pencil. In this manner many of my diagrams have been made. They must of course be accurate copies of the objects themselves, and are therefore far more truthful than diagrams copied from drawings representing microscopical structure, can be. In making microscopical drawings it is usual to fix the paper from the centre of the eye-lens at some arbitrary distance, as 10 inches. If the distance be always the same, the drawings so obtained may be compared with each other, and scales

of measurement may be appended to them by proceeding in the manner described in fig. 63.

Mr. Conrad W. Cooke, in 1865, designed a new instrument for drawing which he terms a "micrographic camera." By this instrument an image can be thrown on a sheet of paper placed in a horizontal or slanting position, so that anyone may trace on the paper the outlines and detail with a fair amount of accuracy. It is useful also for purposes of demonstration, for two or more persons may at the same time conveniently examine the image formed on the paper. The head of the observer is isolated from external light by means of a curtain which falls over the back of his chair. Measurement of the objects shown in this camera may very easily be made, and boxwood scales corresponding to the magnifying powers of the different objectives are furnished. All the necessary adjustments can be effected from the inside, in order to avoid the inconvenience to the observer of continually altering his position. The use of the microscope is not entirely confined to the examination of transparent objects, for an image of many of the opaque preparations may be shown with it on the paper. The effects of dark ground illumination (with the paraboloid and other instruments) and those of the polariscope may be shown on the paper without loss of definition; and all these accessories, as well as the objectives used, are the same as those of a microscope of the ordinary construction. The whole apparatus is made to fold up so as to occupy as little space as possible, for the sake of portability. I believe the arrangement, which, however, is not adapted for high magnifying powers, can be furnished by Mr. Ross.

**46. Of making Drawings which it is intended should be Engraved.**

—With a little practice, the observer may acquire the power of drawing on wood, and the engraver will often be able to produce a more faithful representation of the object than he could by copying the drawings of the microscopical observer. The drawing should first be made roughly on paper, in order to obtain the size and general characters of the object. A piece of retransfer paper is then placed upon the prepared block, and the prominent lines of the drawing traced with some blunt-pointed instrument (a needle, the point of which has been made slightly blunt by filing it, answers very well). By using a slight pressure, the colour of the retransfer paper is transferred to the wood block in the lines corresponding to those of the drawing. These lines are afterwards reproduced by lead pencil, corrected, if necessary, and the delicate parts of the drawing filled in by carefully copying from the object.

If the engraving is to be a fac-simile of the drawing with the different parts on corresponding sides, it is necessary, in the first place, to copy the picture with ordinary tracing paper, and *invert* the tracing upon the retransfer paper on the wood block, as the impressions are of course always reversed; or a reverse may be obtained by copying the image of the drawing reflected from a looking-glass. Specimens of wood engraving are seen in many of the plates in this volume.

**47. Pencils.**—Many excellent lead pencils are now made. Those known as Faber's, *rs. 9d.* a-dozen, are among the best and cheapest HH's or HHH's are sufficiently hard for ordinary drawing on paper, but for drawing on wood a four or five H is to be preferred. Drawings of microscopic objects may also be made with India ink or sepia, a fine brush or pen being used. If the observer draws on wood, he will save time by representing the shading as a *tint*, and different kinds of shading may be indicated by different colours applied with a camel's hair brush in the usual way.

**48. Tracing Paper** is a very transparent paper, obtained by soaking tissue paper in some oily material, and allowing it to dry. Retracing paper consists of tracing paper, upon one side of which a fine red, blue, or black powder has been rubbed, which adheres to the paper pretty firmly, but which, at the same time, will readily adhere to another surface if firm pressure be applied.

**49. Wood Blocks** are *prepared* by rubbing a little dry carbonate of lead and brick dust moistened with water upon the surface, and allowing a very little to dry on. In this way a smooth white surface is obtained, admirably adapted for receiving the most delicate drawing. It is well to moisten the white lead with a little very weak gum water, which makes it adhere firmly to the surface and gives a very smooth face. If the face of the block is not smooth, it may be rubbed with the hand or a piece of hard paper or wash leather. Every observer should learn to draw on the wood block himself. There is no great difficulty, and a little practice will enable him to draw as well on wood as on card-board.

**50. Of obtaining Lithographs of Microscopical Drawings.**—I think it desirable to give a few directions for drawing on stone, as I believe there are many observers who would willingly give up the necessary time required to place their work on the stone, who could not afford to employ a lithographic artist. I made many drawings in this manner some years ago (*see* the earlier numbers of my 'Archives') and with the help of a boy, who could at first draw but little, have been able to publish numerous drawings, which are very accu-

rate copies of the objects, although in execution they will not bear comparison with artists' work.

**51. Drawing on Transfer Paper.**—If the drawing does not contain much very minute work, it may be drawn on properly *prepared transfer paper* with lead pencil, direct from the microscope. Afterwards, the lines are to be traced with a pen with lithographic ink; the shading may be effected by delicate lines made with the pen, or with lithographic chalk. The latter plan, however, is not well adapted for making transfer drawings. The drawing is then to be sent to the lithographic printers, where it is damped, placed downwards on a dry stone, and after being subjected to firm pressure, the paper is peeled off, and the preparation, with the drawing, left on the stone. The latter is removed with water, the drawing properly set, and the printing ink applied with the roller.

**52. Transfer Paper** is prepared for the purpose. Some which was made of India paper, supplied to me by Messrs. Harrison and Sons, St. Martin's Lane, I found answered exceeding well.

**53. Drawing on the Stone.**—There are two plans for drawing on the stone itself, which produce better results than the preceding method, but they require more practice for their satisfactory execution. When much shading is required, and extreme delicacy of outline is unnecessary, the outline is first made on paper, and the drawing retraced on the stone in the manner described in § 46; the outline may then be traced with ink—a pen, or very fine sable hair brush, being used for the purpose; the shading is to be given with the lithographic chalk. The chalk is to be very finely pointed by cutting downwards, the point being uppermost (as in pointing an ordinary chalk crayon), and held in a handle made out of a common quill. The lines are to be made very gently, repeating the strokes frequently with a light hand, when depth of colour is required, rather than by leaning heavily so as to remove a considerable quantity of chalk at once, and deposit it upon the stones. When chalk shading is employed, a finely *grained* stone is required.

**54. Of Engraving on Stone.**—If the work is very delicate, as is the case with most subjects the microscopical observer wishes to obtain representations of, engraving on stone is to be preferred. The process is very simple, but if the observer desires to obtain good results, he must be content to spend some time in practice. The stone must be finely polished, and it is well to have it tinted with a little infusion of logwood, or to cover it with a thin layer of lamp black, which enables the draughtsman to see his strokes better. The outline of the drawing is traced as before, and then the lines scratched upon the stone with a very fine point. A needle point, previously



hardened by being heated red hot and suddenly dipped in cold water, inserted into a strong handle, may be used. I generally use an etching needle; the point requires to be sharpened from time to time upon a hone. But a properly pointed diamond is far better. The dark parts are shaded by lines placed very close together, or cross shading may be adopted, or the tint may be given by dots, as in copper-plate engravings. Generally it is better to try to obtain the appearance of texture by copying, as nearly as possible, the character of the tints of the object itself. The thickness of the line in the impression will depend upon the width of the line on the stone, without any reference to the *depth* to which it extends into it. It is desirable to make two or three narrow lines near to each other, instead of one wide one, when a thick line is required. After all the lines have been scratched the stone is sent to the lithographic printer, who will obtain impressions from it. The oily material which is applied adheres to the rough scratches only, and subsequently when the stone is wetted, the ink only attaches itself to the oily parts.

**55. Lithographic Ink, Lithographic Stones.**—The ink may be obtained in the fluid state, but it is better to use the solid ink, a little of which is rubbed up with water when required. Lithographic chalk may be obtained of different degrees of hardness,—it can always be made much harder by melting it and rolling it into sticks.\*

The stones are sold by the pound. It is desirable to obtain stones large enough to hold four octavo pages of drawings, as the expense of working a stone of this size is a but little more than one large enough to contain only a single plate.

**56. Of representing Peculiarities of Texture.**—Success in drawing microscopical specimens, depends mainly upon a careful study of the different methods of shading, by which the idea of texture may be given, as well as mere light and shade. It is most difficult to give general directions on this matter, and much depends upon the method of illustration determined upon. Various tints and textures would be produced in a different manner according as the drawings are engraved on copper, stone, or wood. I have no doubt that the most perfect results can be obtained on steel, copper, or stone, but the expense of these methods is a serious objection, and for some years past I have abandoned them in favour of wood engraving which has many advan-

\* The apparatus, ink, chalk, &c., alluded to, can be obtained of Messrs. Waterlow, Messrs. Hughes and Kimber, Red Lion Court, Fleet Street, and most lithographers. It is only due to Messrs. Harrison, of St. Martin's Lane, that I should thank them for the kindness they have always displayed in assisting me in carrying out this and many other plans of producing drawings. Without the important help they and their workmen have afforded me, on all occasions, my efforts would probably have failed, as I had no knowledge of practical lithography.

tages, especially where a great number of illustrations is required. It is surprising what differences of texture may be rendered on wood. The observer must of course learn to draw on the block himself, and either copy the particular shading he requires from other engravings, or with the assistance of the engraver, must try various plans of his own. By drawing on the wood himself, not only does he save one third of the cost, but far more faithful representations of natural structures are obtained. In many of the plates of this volume illustrations of different kinds of work will be found. By attentive examination the reader will see how each different appearance is produced. None of the different kinds of shading represented are very expensive, and it will be observed that cross shading with dark lines, which is most expensive in wood engraving, has been entirely avoided. The wood engraver is obliged, unless expense is no object, to shade as much as possible with parallel lines, which system entirely fails to produce the appearances required by the microscopist. However, by simply breaking these lines at short intervals by white lines and keeping them a little irregular, a variety of truthful characters may be produced and at very little cost.

There can be no doubt that much more perfect results would be obtained in wood engraving, if the observer not only drew upon the block but engraved the drawings himself, and I see no reason why many might not do this. The art of wood engraving may be learnt in a few months, and although the process is tedious and occupies some time, I am sure that the greater perfection of the results would more than compensate. It may be possible in certain cases for some members of the family to engrave the work under the eye of the observer, and in this way the engraving will be almost as good as if the latter had performed the whole work. Wood engraving is a delightful occupation for ladies who have the time to devote to it. The only instruction required may be learnt in Mr. Thomas Gilk's little book "The Art of Wood Engraving" published for 1s., by Winsor and Newton, 38, Rathbone Place. The apparatus and the few tools required may be obtained at many of the tool-makers, of Messrs. Winsor and Newton, and other artists' colourmen.

**57. On the Importance of Observers delineating their own Work.**

—It will, I know, be said that these processes, above described, are of a nature which any intelligent draughtsman can perform, and hardly worth the labour which a microscopical observer, who wishes to carry them out, must be content to bestow. And objections of other kinds might be urged, but I feel that if I had been unable to have the lithographs and drawings executed at home, many of the

illustrations in my works could not have been published. Remembering how much I needed at one time the little information given here—I gladly communicate it, imperfect as it is, in case there may be others in the same situation as I was.

The student must not, however, suppose that the task is an easy one. It is quite as impossible to obtain a good representation of any microscopic object without long and careful study, as it is to produce a copy of any other object in nature; and surely it is hard to expect a draughtsman, who is engaged in copying various subjects to spend hours in looking at specimens in a microscope, observing things which he neither knows nor perhaps desires to know anything about. Neither is it possible that any one man can make himself fully conversant with all the beautiful minutiae in every branch of microscopic enquiry. It is true that Mr. Tuffen West, and one or two other gentlemen, have taken up this kind of drawing and engraving, and have produced most beautiful results. I believe Mr. West's success as an engraver of microscopic objects to be due to the interest he takes in the subject, and to his being himself a practical microscopical observer. There are many drawings of microscopic objects which ought to be published, and although these may be of little interest to persons generally, are absolutely required by those who are working at special subjects. However rich a man may be, it is doubtful if a large sum of money should be spent in employing artists to do work which, however well skilled they may be, they cannot do so truthfully as the observer himself, unless they have devoted the same attention to the subject. Few artists have time or inclination for this. There is not, however, the same difficulty as regards our own time. That which is worth recording is worth an expenditure of time, is worth doing well. Whatever is observed is worth copying, if it has not been correctly copied before.

Very much yet remains to be done in representing microscopic texture faithfully. Photography has advanced wonderfully, and will doubtless, assist us more, but there are many structures the colour of which alone renders it quite impossible to obtain photographs of them, and there must always be many appearances which can only be rendered by accurately copying them by hand. I cannot, therefore, too strongly urge on all those who wish to work at the microscope, to practise drawing as much as possible; and from the first. All advance in our knowledge of structure, as well as of the minute changes incessantly going on in living organisms, depends I think, in great measure, upon accurate copies of the objects being made, and in this way only is it likely that the work of the present generation will be useful to that which succeeds it.

It is beyond the power of language to describe the characters of many structures in such a way that their appearance could be reproduced in the mind of another, and even if this could be done, so wonderfully delicate and minute are the observed differences in many cases, that any attempt to classify and arrange our observations, without drawings, would be hopeless, and must become more impossible in proportion as observations multiply ; while the different meaning which different persons attach to the same words and phrases, introduces another difficulty in our attempt to collate and deduce inferences from the observations which have been made.

Now surely, at this present time, our knowledge would have been much more extensive as well as more accurate, if instead of long descriptions we had been furnished with accurate drawings of the minute structure. It is true that all persons cannot draw well, but a very little patience will enable any one to copy a microscopical specimen. An accurate copy, although it be very roughly executed, has an aspect of truth which is unmistakeable, while a drawing which is the offspring of the imagination instead of a simple copy of nature, bears the mark of untruth in every line, however elaborate and unexceptionable its execution may be. Errors of observation are, I am convinced, much more easily detected in a drawing than in verbal description. A mistake or misinterpretation expressed in a drawing can, and at length must be, corrected by subsequent observation, while ill-observed or misinterpreted facts, cloaked in obscure language, may be propagated for years, and no matter how false they are, it may be very difficult to refute them. I would, therefore, urge upon every one the importance of making drawings at whatever cost of time and labour ; it is worth any sacrifice to do really good work, and if every observer could but record a few accurate delineations of structure during his life, the result of the united labour of those now working would be very great.

I would also strongly urge upon observers the importance of at once agreeing upon some general plan of delineating objects, so that our observations may be useful to all, while the task of those who will hereafter have to arrange and deduce conclusions from our work will be much facilitated. The value of many beautiful drawings would be greatly increased if a scale of 100ths or 1000ths of an inch was appended to them, and the magnifying power of the object-glass stated. This would not have added five minutes to the time required for the task, while it would have rendered the drawings comparable with others. In some, the magnifying power is not even mentioned, and in others there is reason to believe it has been wrongly computed. Every one who copies an object should state

the magnifying power of the combination of lenses he employed, and should append a scale magnified by the same combination, *See* § 64.

But the reader must not conclude that I am insensible to my own shortcomings in these and many other matters. I am conscious that every drawing I have published might have been, and ought to have been—better. I can only hope therefore that the desire for seeing our work useful to each other and to our successors, as well as to ourselves, will be received as a sufficient apology for these remarks.

ON MEASURING OBJECTS AND ASCERTAINING THE MAGNIFYING  
POWER OF OBJECT-GLASSES.

Most of the larger and complete microscopes are furnished with special micrometers, but the simple method of measuring objects, presently to be described, to a great extent supersedes more expensive arrangements. It will be well for me, perhaps, in the first place, to describe briefly the different forms of micrometers in use.

**58. The Cobweb Micrometer**, originally applied to telescopes by Ramsden, its inventor, can be fitted to the upper part of the body of the microscope. A fixed cobweb crosses the field of view, and parallel to this is another cobweb thread capable of being brought near to, or separated from the first, by turning a milled head, to which is attached a graduated circle. The value of each degree on the circle is ascertained by placing an object of known dimensions, as the *stage micrometer* graduated to thousandths, under the object-glass, and ascertaining the number of degrees on the screw which corresponds to the 1-1000th of an inch. From these data a simple table may be constructed, and the diameter of any object can be readily ascertained by bringing one side of it up to the fixed line, and causing the moveable line to touch the opposite. If we ascertain the value of the degrees as marked upon the circle when the lines are separated at the proper distance, we may estimate directly the diameter of the object. The older observers used to measure objects by means of very delicate wires, separated from each other by certain known distances, placed in the focus of the eye-piece, or by employing points, one of which could be moved from, or towards, the other by means of a screw.

**59. Jackson's Eye-piece Micrometers.**—Mr. Jackson arranged a micrometer slide in the eye-piece so that it could be brought over the magnified image of the object by means of a screw.

**60. Stage Micrometers.**—Within the last few years, lines, separated from each other by certain known but very minute intervals,

have been ruled upon slips of glass by means of a diamond attached to a beautiful instrument, provided with a most delicate arrangement for moving it the required distance from the last line engraved. A second line is then ruled, then a third, and so on. Excellent stage micrometers of this kind have been ruled by the late Mr. Jackson. They can be obtained of all the instrument makers; but they are made by Messrs. Powell and Lealand.

**61. Test Objects.**—To such wonderful perfection has this process been carried, that M. Nobert of Griefswald, in Prussia, has engraved lines upon glass so close together that more than 100,000 would go in the space of an English inch. Several bands, each containing many lines equidistant from one another, were engraved upon one slip of glass, but the lines in each different band were separated by gradually diminishing intervals, constituting a series which could be readily submitted to examination one after another. By aid of these the *defining power of any object-glass could be estimated*. As test objects, they are equal to, and even rival, many natural objects which have hitherto been employed for this purpose. The delicate lines on some of the diatomaceæ are separated from each other by the 1-50,000th of an inch, while the finest lines engraved by M. Nobert are less than the 1-100,000th of an inch apart.

In order to measure the diameter of an object the glass slide upon which the lines have been engraved (1-1000th or 1-100th of an inch apart according to the magnifying power) may be placed beneath the object upon the stage. This arrangement, however, is only suitable for low powers, since the object and lines cannot be in focus at the same moment, and it is, therefore, impossible to obtain a very correct measurement.

The podura scale is a most excellent "test object." According to Prof. Bailey of the United States, *Grammatophora subtilissima* and *Hyalodiscus subtilis*, are the most delicate tests ("Smithsonian Contributions," vols. II and VII; also a paper by Mr. Hendry, "Quart. Journ. Mic. Science," vol. I, p. 179, 1861; one by Messrs. Sullivant and Wormley, "Silliman's American Journal," Jan. 1861).

For testing the penetrating power of an object-glass, very fine nerve fibres lying on different planes, as, for example, those distributed to vessels, or very delicate fibres of striated muscle, mounted in glycerine, may be employed. It should be borne in mind that the object-glasses with a very high angle, although very valuable for researches upon the diatomaceæ, and other delicate objects of extreme tenuity, do not answer so well for investigations upon the structure of animal and vegetable tissues, as glasses of a moderate or very low angle. This question is fully discussed in the remarks on

“Test Objects,” by Dr. Carpenter, “The Microscope and its Revelations,” pp. 141, et seq.

**62. Simple Method of Measuring Objects.**—The most simple and efficacious manner of measuring objects is with the aid of the camera lucida or neutral tint-glass reflector referred to before, § 44. In the field of the microscope is placed an ordinary micrometer, with the lines separated by thousandths of an inch. Care being taken that the instrument is arranged at the proper distance from the paper, the lines magnified by a quarter of an inch object-glass are carefully traced. The micrometer is removed and replaced by the object whose diameter is to be ascertained. In pl. XIII, fig. 64, both micrometer lines and objects are shown magnified by the same power. The object is traced over the lines, or upon another piece of paper, and compared with the scale by the aid of compasses. The lines may be engraved upon a slate, or upon pieces of ivory or cardboard, and their value affixed, so that any object may be at once measured. We require of course a different scale for each power. Such scales may be made on pieces of gummed paper, and one of them may be affixed to every microscopical drawing. Fig. 63 shows several such scales magnified by different powers. Thus the size of every object delineated may be at once ascertained, and the trouble of making individual measurements saved, while at the same time the inconvenience of a long description of the dimensions of various objects is avoided, than which nothing can be more tedious or less profitable to the reader.

In comparing the representation of the same object delineated by different observers, it will be found that great confusion has been produced in consequence of the magnifying power of the object-glass not having been accurately ascertained, and an object said to be magnified the same number of times by two authorities, is not unfrequently represented much larger by one than by the other. This discrepancy in most cases arises from the magnifying power of the glasses not having been accurately ascertained in the first instance. I cannot, therefore, too strongly recommend all microscopic observers to ascertain for themselves the *magnifying power of every object-glass* and to prepare, in the manner presently to be described, *a scale of measurement by which the dimensions of every object can be at once ascertained.* The plan of appending to every microscopical drawing a scale magnified in the same degree as the object represented, supersedes the necessity of giving measurements in the text, while it is free from any of the objections above referred to.

**63. On Ascertaining the Magnifying Power of Object-glasses.**—I will now describe the method of ascertaining the magnifying

power of the different lenses. Although the several object-glasses are termed one inch, one quarter of an inch, one eighth, &c., the magnifying power of each is not definite, and the quarters of some makers magnify with the same eye-piece many times more than those of others. It is well, therefore, that every observer should be able to ascertain for himself the magnifying power of his different glasses. Suppose I wish to know how much a French quarter magnifies. The one-thousandth of an inch micrometer is placed in the field, and the magnified image is thrown by means of the neutral tint-glass reflector upon a scale, divided into inches and tenths of inches placed ten inches below the eye-piece. If the magnified one-thousandth of an inch covers about two-tenths of an inch, the glass magnifies 200 diameters; if it covered one inch, the thousandth of an inch must have been magnified 1,000 times, but in this case it only corresponds to the one-fifth of an inch, and therefore the one-thousandth is magnified 200 times. For lower powers the one-hundredth of an inch scale may be employed. The manner of ascertaining the magnifying power is therefore exceedingly simple; but it is very important for the observer to know the magnifying power of every lens with each different eye-piece, and he should ascertain this before he commences to make any observations. This simple process will be readily understood if fig. 66, in pl. XIII, be carefully studied. To carry out this plan it is only necessary to be provided with a stage micrometer, divided to 100ths and 1,000ths of an inch, which can be purchased for 5*s.* *od.*, and an inch scale divided to tenths.

**64. To Ascertain the Diameter of an Object.**—If an object be substituted for the micrometer, and its outline carefully traced upon paper, its dimensions may of course be easily ascertained by comparison with the micrometer lines. The magnifying power used being the same in both cases.

In order to apply this plan to microscopical drawings generally, the following seems to be the simplest mode of proceeding, and saves much trouble. Scales are carefully drawn upon gummed paper; the magnifying power, and the micrometer employed being written upon as represented in pl. XIII, fig. 63. If a number are drawn together, one of the rows can be cut off and appended to the paper upon which the drawing, magnified in the same degree, has been made. The observer may save himself the trouble of drawing these on paper, by having them engraved on wood or stone, and several copies worked off. This is the plan I have followed in all the drawings which illustrate my observations, and the scales have been copied in the wood-cuts and plates.



**65. Standards of Measurement.**—In this country we usually employ the English inch, but on the continent the Paris line =  $\cdot 0888$ , or about  $\frac{1}{11}$ th of an English inch, is very generally used. The sign "'' is used to signify "of a line," and has been employed by Professor Kölliker in his works, while "'' signifies "of an inch."

**66. Conversion of Foreign Standards of Measurements.**—In order to compare the researches of different authors, it is often necessary to convert one expression of measurement into another. The accompanying table of Dr. Robertson's ("Edin. Month. Jour. of Science," Jan. 1852) will be found of great use in making these calculations. See Table p. 40.

Deputy Inspector-General Lawson gives the following rules for converting different standards of measurement in a paper communicated to my "Archives" (vol. II, page 292). A unit is required that will admit of microscopic measurements being expressed in the smallest number of figures, and permit of foreign measures being easily converted into English, and *vice versa*, and the decimal notation should be adopted to facilitate comparison between the measurements.

Most microscopic measurements are under the hundredth of an inch, one hundred-thousandth of an inch can only be measured with certainty when magnified by the  $\frac{1}{25}$ th or  $\frac{1}{50}$ th. See part V. The requirements of the case therefore may be stated in decimals of an English inch by  $\cdot 00101$ , and if the two ciphers next the decimal point be struck out, and the first number be considered the unit, it may be written  $1\cdot 01$ , in which a thousandth of an inch is the unit. This method will embrace nearly every microscopic magnitude in three consecutive figures.

The foreign measures are the *millimetre* and the *French and Prussian lines*. The two latter are so nearly equal, that the same rule will serve for the conversion of both.

A millimetre contains  $\cdot 03937$  English inch or  $39\cdot 37$ ; according to the method proposed, the length to be converted will seldom amount to one fourth of this. To convert millimetres into thousandths, shift the decimal point one place to the right and multiply by 4; if greater accuracy be required, subtract  $1\frac{1}{2}$  from the second place of decimals for each of the nearest numbers of units of the product. Thus  $0\text{mm}\cdot 250$  becomes  $2\cdot 50$  which  $\times 4 = 10\cdot 00$ , from which subtract  $\cdot 15$ ; and  $9\cdot 35$  is obtained as the value in thousandths of an English inch, while  $0\text{mm}\cdot 25$  is equal to  $9\cdot 84$ , which differs from the former by a quantity too small to measure.

To convert thousandths of English inches into millimetres, add  $1\frac{1}{2}$  in the second place of decimals for the nearest number of units

TABLE FOR MUTUAL CONVERSION OF BRITISH AND FOREIGN LINEAL MEASUREMENTS.

	1	2	3	4	5	6	7	8	9
To convert—									
1. British inches into Milli- metres {	25.39954	50.79908	76.19862	101.59816	126.9977	152.3972	177.7968	203.1963	228.5959
2. Do. Old Paris Lines ..... }	11.25936	22.51872	33.77808	45.03744	56.29680	67.55616	78.81552	90.07488	101.33424
3. { Rhineland or Prussian Lines }	11.65275	23.30550	34.95824	46.61099	58.26374	69.91649	81.56923	93.22198	104.87473
4. Millimetres into British Inches {	.0393.079	.0787158	.1181237	.1574816	.1968396	.2362474	.2756553	.3149632	.3543711
5. Do. Old Paris Line ..... }	.44329	.88658	1.32987	1.77316	2.21645	2.65974	3.10303	3.54632	3.98961
6. { Rhineland or Prussian Lines }	.45578	.91156	1.36734	1.82312	2.27890	2.73468	3.19046	3.64624	4.10202
7. Old Paris Lines into British inches {	.088815	.177630	.266445	.355260	.444075	.532890	.621705	.710520	.799335
8. Do. Millimetres ..... }	2.25586	4.51172	6.76758	9.02344	11.27930	13.53516	15.79102	18.04688	20.30274
9. { Rhineland or Prussian Lines }	1.03494	2.06988	3.10482	4.13976	5.17469	6.20963	7.24457	8.27951	9.31445
10. Rhineland or Prussian Lines into British Inches {	.088817	.177633	.266445	.355260	.444075	.532890	.621705	.710520	.799335
11. Do. Millimetres ..... }	2.17074	4.34148	6.51222	8.68296	10.85370	13.02444	15.19518	17.36592	19.53666
12. Old Paris Lines ..... }	.9662407	1.9324814	2.8987221	3.8649628	4.8312035	5.7974442	6.7636848	7.7299255	8.6961662

Illustrations of Use of the above Table.

**I.—EXAMPLE.**  
Given 245.9023 Paris Lines. Required the value in British inches.  
By line seven of Table—  
Old Paris Lines.      British inches.  
200      =      17.7050  
+      40      =      3.55460  
+      5      =      .441075  
=      .9      =      .0799335  
=      .0023      =      .000256445  
21.830635445 British inches.  
Data, from which the Table has been calculated, extracted from Mr. Woodhouse's Table in the "Encyc. Metropolitan,"—British foot = 1. Metre = 3.2808992.  
Old Paris foot = .060578. Rhineland or Prussian foot = 1.0248.

**II.—EXAMPLE.**  
Given .00215 Millimetres. Required the value in British inches.  
By line four of Table—  
Millimetres.      British inches.  
.002      =      .0000787415  
+      .0001      =      .00003937079  
+      .00005      =      .0000196853915  
.0000846171975 British inches.  
Data, from which the Table has been calculated, extracted from Mr. Woodhouse's Table in the "Encyc. Metropolitan,"—British foot = 1. Metre = 3.2808992.  
Old Paris foot = .060578. Rhineland or Prussian foot = 1.0248.

**III.—EXAMPLE.**  
Where extreme exactitude is not required, only one or two decimal places need be used. Thus—  
Given 24.8396 British inches. Required the value in Paris Lines.  
By line two of Table—  
British inches.      Paris Lines.  
20      =      225.19  
+      1      =      11.26  
+      .8      =      9.01  
+      .04      =      .45  
245.91 Paris Lines very nearly.  
Data, from which the Table has been calculated, extracted from Mr. Woodhouse's Table in the "Encyc. Metropolitan,"—British foot = 1. Metre = 3.2808992.  
Old Paris foot = .060578. Rhineland or Prussian foot = 1.0248.

in the sum, divide by 4, and shift the decimal point one place to the left, thus—to  $9^{\cdot}84$  add  $^{\cdot}15$  and the sum  $6^{\cdot}999 \div 4 = 2^{\cdot}498$ , and shifting the decimal point  $^{\text{mm}}\cdot 2498$  which does not differ sensibly from  $^{\text{mm}}\cdot 25$ , the correct quantity.

A French line contains  $\cdot 0888$  English inches. To convert lines into thousandths of an inch, shift the decimal point one place to the right, and multiply by 9; if greater accuracy be required, subtract  $1\frac{1}{3}$  from the second place of decimals for each of the nearest number of units in the product. Thus  $0^{\text{'''}}\cdot 125$  becomes  $1^{\cdot}25$  which  $\times 9 = 11^{\cdot}25$ , from which subtract  $^{\cdot}14$ , and the value in thousandths is found to be  $11^{\cdot}10$ , which is correct.

To count thousandths into lines add  $1\frac{1}{3}$  in the second place of decimals for each of the nearest number of units in the sum, divide by 9, and shift the decimal point one place to the left, thus—to  $11^{\cdot}10$ , add  $^{\cdot}14$ , the sum  $11^{\cdot}25$  divided by 9, and the decimal point shifted one place to the left gives  $0^{\text{'''}}\cdot 125$  as before,

In most cases it will be unnecessary to apply the corrections noticed above, but by remembering the short rules given, any one on reading a foreign work may correct the measurements as he reads, and insert them in the margin without delay or interfering with his progress.

*Method of finding the same Spot in a Specimen.*

**67. Of marking the Position of an Object.**—Various plans have been proposed from time to time for marking the exact position of a minute object in a specimen, so that it can be placed in the field of the microscope whenever required. A fine line of varnish or Brunswick black may be drawn round it, or a small and very thin metal tube (about the tenth of an inch in diameter) may be moistened with the varnish and pressed upon the glass cover, so as to encircle the particular object required with the line.

Mr. Bridgman, of Norwich, has designed an instrument for drawing a circle upon the thin glass with a diamond point (*Microscopical Journal*, vol. III, p. 237). This instrument is represented in pl. XIII, fig. 67. A is a brass cap fitting upon the end of the object-glass, which it entirely covers up and protects from injury; B, a stem soldered to the side of the cap with the upper end having two projecting sides to steady the ends of C, *e*, and *f*, which are firmly secured to it; C, an elastic arm of hammered brass, which carries at its lower end D, a lever of thin brass plate, having a fragment of diamond inserted in its thinner end, and directly under the centre of the cap A; *e* and *f* are two springs, pressing upon the shorter end

of the lever *D*, the longer one *f* has a hole to allow the screw *h* to pass without touching it; *g*, a screw holding the two springs and the elastic arm to the arm of the cap; *h*, a milled screw to adjust the elastic arm *C*, so as to bring the diamond point away from the centre, according to the size of the ring required. When the object has been found, the cap carrying the diamond is placed on the object-glass and carefully adjusted, so that the diamond point is brought into contact with the surface of the glass, it is then turned round, and thus a line is drawn round any object which can be readily found at any future time.

This same end has been gained in another manner. Graduated scales have been affixed to the stage of the microscope, so as to measure the exact amount of movement in the vertical and horizontal direction; the slide being placed in position against a stop at the side. The number on the two scales is noted when the object is seen in the field, and, by placing the stage opposite the same numbers, at any future time the object must appear in the same position. Various ingenious "finders" have been proposed. A very simple and efficient one is represented in pl. XIII, fig. 62, in which the scales are ruled on paper (Mr. Wright, *Microscopical Journal*, vol. I, p. 302, 1853), which is afterwards fixed upon the stage. It is better to have the lines ruled on the brass itself.

*Bailey's Universal Indicator*.—Mr. J. W. Bailey, of the United States, has described an instrument for registering the positions of various objects upon a slide, in vol. IV of the *Quarterly Journal of Microscopical Science*. This indicator is to be firmly fixed to the stage of the microscope, care being taken that the centre of the indicator corresponds to the centre of the object-glass. The mode of using the indicator is obvious.

All such devices have, however, been superseded in cases where the microscope is provided with a travelling stage, by the two following very clever arrangements, the first suggested by Mr. Maltwood (*Trans. Microscopical Society*, vol. VI, p. 59, 1858), the second by Mr. Bridgman, of Norwich. In order to use Maltwood's finder, a little stop is placed upon one side of the stage, in contact with which one end of the finder, and afterwards the glass slide containing the object can be placed. The finder consists of a plate of glass, upon which numbers are arranged in minute squares. These run in two directions, vertically and horizontally, so that in each square there are two different numbers, except in the case of the central square, which of course contains two 25s. Any object having been found, its exact position may be registered by removing the slide and placing on the stage the finder. The numbers seen in the field are then

marked on the slide itself, and the same spot can always be found by looking for these numbers on the finder, moving the stage till they come in the centre, and then substituting the slide for the finder. The numbers and lines are photographed on the finder which is made by Messrs. Smith and Beck, and costs 7s. 6*d.* A few of the squares of a Maltwood's finder are represented in pl. XIII, fig. 65.

**68. Mr. Bridgman's Finder** which is sold by Mr. Baker, of Holborn, consists of a curved bar fixed to the stand of the microscope and capable of being moved upwards and downwards upon a hinge joint. The bar terminates with a fine point, and when pressed down, this point comes upon a piece of paper gummed to one end of the slide and makes a slight prick, or it may be tipped with ink if preferred. When the observer sees an object which he desires to find again, a mark is made with the point. In order to find this same spot at any future time, it is of course only necessary to place the slide in such a position that the original mark exactly corresponds with the point of the finder, and the part of the specimen must then be again in the centre of the field. The plan is so simple and efficacious, that it will, I think, completely supersede the various finders now in use.

#### INSTRUMENTS AND APPARATUS REQUIRED IN GENERAL MICROSCOPICAL RESEARCH.

**69. Spirit Lamp.**—The spirit lamp may be made of brass, tin, or glass fitted with a ground glass cap. It may be fitted with a stand for holding watch-glasses, pl. XIV, fig. 70. Brass lamps, to which a small retort-stand is fitted, may also be purchased of the instrument makers.

**70. Wire Retort Stands.**—Simple wire stands, made like retort-stands, which are fixed to a heavy leaden foot, will be found exceedingly useful little instruments to the microscopical observer. The rings can be readily raised or lowered at pleasure, and are well adapted to support light objects, such as glass slides over a lamp, test-tubes, flasks, and watch-glasses, pl. XIV, fig. 69.

**71. Tripods** are made of thick iron wire, and are useful for supporting several pieces of apparatus used in microscopical research, pl. XIV, figs. 71, 72.

**72. Brass Plate.**—The brass plate should be about six inches long by two broad, and about the thickness of thin millboard. It should be supported on three legs, of a convenient height for the spirit or other lamp to be placed underneath, or the brass plate may be supported on one of the rings adapted to Mr. Highley's lamp. It is used

for heating glass slides, in order to fix on the glass cells with the aid of marine glue, for mounting objects in Canada balsam, and for other purposes, where a uniform degree of heat is required to be applied to glass, which is very liable to crack if exposed suddenly to the naked flame. These different pieces of apparatus have been figured in pl. XIV, fig. 68.

**73. The Water Bath** is of great use for drying objects previous to mounting them in Canada balsam. The object may be placed in a small porcelain basin, or large watch-glass, or it may be simply laid upon a flat plate. The basin or plate is then placed over the vessel containing water to which heat may be applied, fig. 73. In order that vessels of different sizes may be heated upon the bath, it is convenient to have a few pieces of thin copper plate, with holes of different sizes cut in them, adapted for watch-glasses and small vessels, fig. 74. The advantage of drying by a steam heat consists in there being no danger of destroying the texture of the object by the application of too high a temperature. A water-bath may be very readily made by placing two porcelain basins one above the other, water being poured into the lower one. These may be supported upon a tripod or upon one of the rings over the spirit lamp, fig. 70.

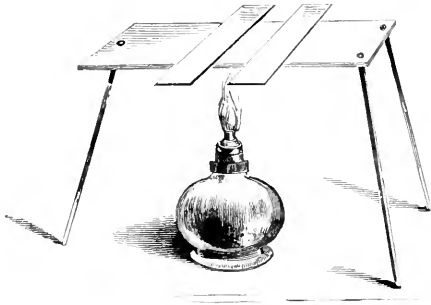
*For Cutting thin Sections of Tissues and Dissection.*

**74. Scalpels.**—It will be convenient to have three or four ordinary dissecting knives or scalpels for general use. One should be strong for the purpose of cutting hard substances.

**75. Double-edged Scalpels.**—For cutting thin sections, a knife of the form of a very narrow lancet will be found useful, and where only sections of small dimensions are required, this will answer all the purposes of Valentin's knife. In cases, however, where a section is wanted of considerable size, the latter instrument must be used. The double-edged scalpel should be very thin, pl. XIV, fig. 75. Beautiful scalpels of this form have been made for me by Messrs. Weiss, of the Strand. In making a section, after cutting a clean surface, the point is made to perforate the surface, and carried along at a proper depth, so as to cut its way out. The width of the section may then be increased by carrying the knife from side to side.

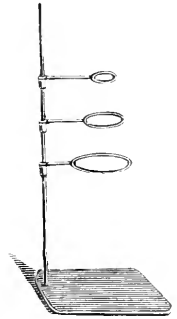
**76. Section Knife of a New Form.**—A new section knife has been devised by Deputy Inspector-General Lawson, for cutting very thin sections of soft tissues. The general form of the knife is represented in pl. XIV, figs. 76 and 77. It is fully described in my Archives, vol. III, p. 286.

Fig. 65.



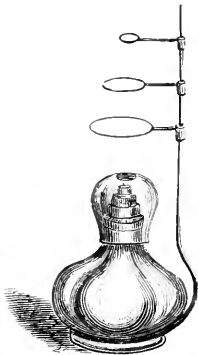
Brass plate for heating glass slides. p. 40.

Fig. 66.



Small rod for standing on edge of watch-glasses. p. 40.

Fig. 70.



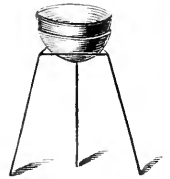
Spirit lamp with wire stand attached. p. 40.

Fig. 71.



Tripled wire stand for holding platinum. p. 43.

Fig. 72.



Specimen tongs attached to a water bath. p. 43.

Fig. 73.



Small copper bath with rim; (a) diminish aperture. p. 44.

Fig. 74.

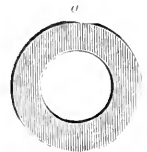


Fig. 75.

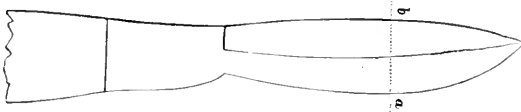


Double-edged scalpel for cutting thin sections. p. 44.

Fig. 77.

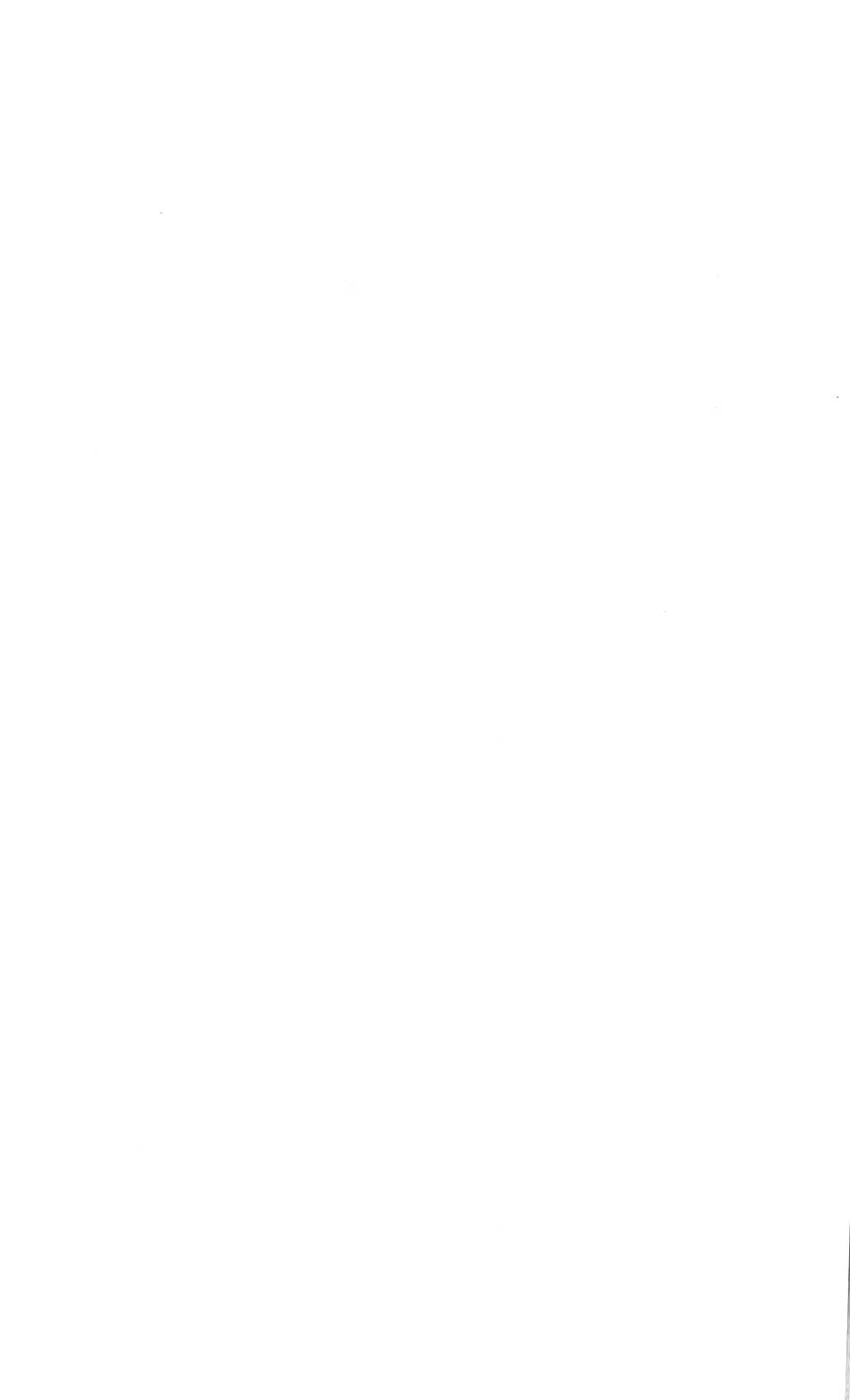


Fig. 76.



New form of section knife. p. 44.

Section of Fig. 76, through a b. p. 44.





**77. Double-bladed or Valentin's Knife.**—This instrument is of the greatest value in making thin sections of soft tissues, but care is required to keep it in good order. It is soon made blunt if used for cutting fibrous or cartilaginous textures. By its aid very beautiful sections of the kidney, liver, and other soft glandular organs may be obtained with the greatest facility. The blades should always be dipped in water or glycerine just before use, for, if wet, the operation of cutting is much facilitated, and the section more easily removed from between the blades. Immediately after use the blades should be washed in water, and dried with a soft cloth, or piece of wash leather. If a drop of water gets into the upper part of the knife where the blades meet, the screw must be taken out, and each blade cleaned separately. With care in cleaning it, the knife may be kept in use a long time.

There are two forms of Valentin's knife; in one the blades are sharp on both edges and of a lancet-shape, and in the other, which I much prefer, they are sharp at the point and wide at the base, so that the cutting edge slants downwards from the point, and they only cut on one side, pl. XV, fig. 79. The best form of Valentin's knife that I have used is that which has lately been made by Mr. Matthews, fig. 78. The blades of this knife can be completely separated from each other and easily cleaned. The distance between the blades is regulated by a little screw, which is a most convenient arrangement. This knife has been further improved by Mr. Matthews, by the addition of two screws, so that the perfect parallelism of the two blades is ensured.

**78. Razor.**—A strong knife made like a razor is very valuable for making sections of many tissues, pl. XV, fig. 81.

**79. Scissars** are useful instruments for cutting small thin sections of different tissues. The most convenient form for this purpose is one in which the blades are curved as in pl. XV, fig. 83. When only very small portions of a tissue are required for examination, they will be more readily removed with the scissars than with any other instrument. Several pairs of scissars are required for microscopical purposes. Besides the ordinary form used for dissection, a small pair, with curved blades, a pair of very delicate scissars with blunt points, fig. 82, such as are employed for the dissection of insects, will be found of use. Some time since, I devised a new form of spring scissars, somewhat resembling the microtome. These are particularly well adapted for dissecting the nervous systems of insects, for following out the delicate ramifications of nerves and other minute dissections, pl. XV, fig. 84.

**80. Needles** of various sizes are very useful instruments to the microscopist. They are employed for making minute dissections; for

tearing or unravelling various tissues, in order to display their elementary structure, and for separating any minute object from refuse or extraneous matter, previous to its being mounted. Very thin needles are useful for separating substances under the field of the microscope. Needles which have been flattened at the points, and subsequently hardened, tempered, and sharpened on the two edges, make capital knives for very delicate work, or the pins used by the surgeons and termed *hardlip pins* may be used with advantage. They may be inserted in a small wooden stick, fig. 80, or held in the handle of a crotchet needle. Mr. Matthews has lately made some needles with cutting edges, which are very useful for making minute dissections.

**81. Forceps.**—A pair of thin brass forceps will be found convenient for applying the thin glass cover after the preparation has been placed upon a slide or in a cell. A pair of dissecting forceps are also required by the microscopist. One pair should be strong with straight limbs, the other pair should be small, with thin curved blades, terminated with somewhat rounded points, having very flat but slightly roughened surfaces of the pattern represented in pl. XV, fig. 85.

Forceps for holding minute objects under the microscope are made to fix upon the stage, fig. 86.

Leaves and feathers and other flat objects can be examined by being placed flat on a glass slide or in the stage forceps. Mr. James Smith has invented a leaf-holder, which may be useful to those desiring to prosecute particular researches in this direction with low powers. This instrument is described in the *Microscopical Journal* for July, 1866, p. 100.

**82. Wooden Forceps** made of box-wood, with broad ends, are convenient for holding the glass slides when hot, for if held with cold metal forceps, they often crack. The same object may be gained more simply by fastening to the limbs of an ordinary pair of forceps, flat pieces of cork. Modifications of the simple spring clips described in p. 52 may be used for the same purpose.

The different instruments above referred to may be obtained packed in a case, of Mr. Collins and Mr. Highley. They are all made by Weedon, of Hart-street.

*Glass Slides, thin Glass, Watch-glasses, Glass Shades.*

**83. Plate Glass Slides**, the edges of which are ground and polished, may be obtained ready for use at six shillings per gross, or they may be easily cut out with the diamond, and the edges ground

Fig. 75.



Valentin's knife, as improved by Mr. Matthews. p. 49.

Fig. 76.



Valentin's knife. p. 49.

Fig. 77.



Needles for dissection. p. 49.

Fig. 78.



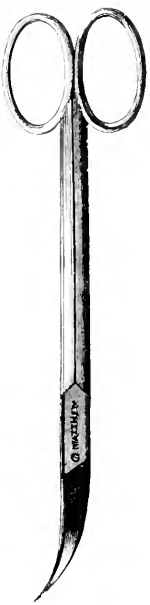
Fine straight saw, for cutting thin sections. p. 49.

Fig. 79.



Fine straight scissors for dissection. p. 49.

Fig. 80.



Curved scissors, for cutting thin sections of tissues. p. 49.

Fig. 81.



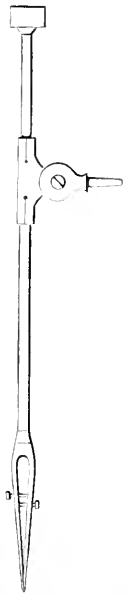
Small forceps, for making minute dissections. p. 49.

Fig. 82.



Curved forceps for minute dissections. p. 49.

Fig. 83.



Forceps which can be attached to the stage of the microscope for holding objects during examination. p. 49.



on the grinding slab. The slides now in common use in this country are three inches in length and one in breadth, and I cannot too strongly recommend the observer to employ slides of this size only for microscopical purposes. They should always be made of plate-glass, and pieces as clear as possible should be selected.

**84. Thin Glass.**—An object placed for examination upon a glass slide is always protected with a piece of thin glass before it is placed upon the stage of the microscope. Thin glass now used for microscopical purposes is called cylinder glass, and is manufactured by Messrs. Chance, of Birmingham. It may be obtained of different degrees of thickness. Thin glass in sheets should be kept in fine sawdust, and it is very readily broken, in consequence of being imperfectly annealed. When cut up in small pieces, it should be kept in a little box, with a little powdered starch, which prevents the pieces being broken. For cutting the thin glass an instrument termed a *writing diamond* is employed, and this is also used by some observers for writing the name of the preparation upon the glass slide. As a general rule, however, I think it better to write the name of the specimen upon a small label which can be gummed to the glass.

*Glass Cells* are described in §§ 124 to 135. Ordinary thin glass of various degrees of thickness, and already cut into squares and circles, may be obtained of Messrs. Claudet and Houghton, High Holborn. For the very high powers the thinnest pieces must be selected from a considerable quantity. Messrs. Powell and Lealand supply the thin glass for use with their twenty-fifth. *See* part V.

Tin cells are referred to in § 118.

**85. Watch-Glasses** of various sizes should be kept by every observer, as they are convenient for many purposes. They cost about a shilling per dozen, and may be obtained of the watch-makers. The lunette glasses are useful for examining substances in fluids with low powers, as in these we are enabled to obtain a considerable extent of fluid of nearly uniform depth.

The little porcelain moulds in which moist colours are kept, and the little circular and oval shallow dishes, are most useful for soaking microscopical specimens in various solutions prior to examination or mounting. They may be covered by circular pieces of glass.

**86. Glass Shades.**—Every microscopist should be provided with from six to twelve small glass shades from two to four or five inches in diameter, to protect objects which are being mounted from the dust. The cheap slightly green propagating glasses, now commonly sold at all the glass shade shops, are most convenient for this purpose. They cost from 2*d.* to 5*s.* These shades are figured in pl. XVI, fig. 87.

Glass slides, thin glass and watch-glasses are included in many of

the cases of instruments and apparatus sold by many of the microscope-makers.

#### CEMENTS.

The chief cements employed in microscopical work, are *Gold size*, *Sealing-wax varnish*, *Solution of shell-lac*, *Solution of asphalt*, *Marine glue*, *Canada balsam*, *Gum*, and a *French cement* composed of lime and India-rubber. These cements are used for attaching the glass cell to the glass slide, for fixing the cover upon the preparation after it has been properly placed in the cell, and for other purposes. The liquid cements should be kept in wide-mouthed bottles, or in capped bottles, fig. 88, pl. XVI.

**87. Gold Size** is prepared by melting together gum animi, boiled linseed oil, red lead, litharge, sulphate of zinc, and turpentine. Gold size adapted for microscopical purposes may be also prepared as follows:—25 parts of linseed oil are to be boiled with one part of red lead, and a third part as much amber, for three hours. The clear fluid is to be poured off and mixed with equal parts of white lead and yellow ochre, which have been previously well pounded. This is to be added in small successive portions, and well mixed; the whole is then again to be well boiled, and the clear fluid poured off for use. In this country it may be obtained of any varnish maker.

**88. Sealing-wax varnish** is easily made by dissolving the best sealing-wax of any colour, in tolerably strong alcohol. This cement is, however, apt to dry rather brittle, and should not, therefore, be used in cases where it is of the greatest importance to keep the cell perfectly air-tight. It forms a good varnish for the last coat. Various colours may be kept according to taste.

**89. Solution of Shell-lac** is recommended by Mr. Ralphs for fixing down the thin glass cover. It is made by dissolving shell-lac in spirits of wine. The shell-lac should be broken in small pieces, placed in a bottle with the spirit, and frequently shaken, until a thick solution is obtained. It dries rapidly, and, if put on in thin layers successively, forms a good cement. It is not acted upon by weak spirit.

**90. Bell's Cement.**—The best cement for specimens immersed in glycerine is sold by Messrs. Bell, chemists, Oxford-street. This, I believe, was originally suggested by Mr. Tomes, but I do not know its exact composition. It appears to contain shell-lac and gold size.

**91. Brunswick Black.**—Solution of asphalt in turpentine commonly known by the name of Brunswick black, may be obtained at

any oil-shop, and forms a most useful cement, both for making very thin cells, and also for fixing on the thin glass covers. If a little solution of India-rubber in mineral naphtha be added to it, there is no danger of the cement cracking when dry. For this hint I have to thank my friend, Mr. Brooke. I have many preparations which have been cemented with Brunswick black which have been kept for upwards of ten years. It is always desirable, however, to paint on a new layer from time to time, perhaps once in twelve months.

Common Brunswick black is made by melting one pound of asphaltum, and then adding half a pound of linseed oil, and a quart of oil of turpentine. The best Brunswick black is prepared by boiling together a quarter of a pound of foreign asphaltum, and four and a quarter ounces of linseed oil, which has been previously boiled with half an ounce of litharge until quite stringy; the mass is then mixed with half a pint of oil of turpentine, or as much as may be required to make it of a proper consistence. It is often improved by being thickened with lamp black. It must be remembered that this cement is soluble in oil of turpentine.

Dr. Eulenstein, of Stuttgart, finds that equal parts of Brunswick black and gold size with a very little Canada balsam form a very lasting cement.

**92. Marine Glue.**—This substance was, I believe, first used for microscopical purposes by Dr. Goadby, of Philadelphia. It is prepared by dissolving, separately, equal parts of shell-lac and India-rubber, in coal or mineral naphtha, and afterwards mixing the solutions thoroughly with the application of heat. It may be rendered thinner by the addition of more naphtha. Marine glue is readily dissolved by naphtha, ether, or solution of potash. It is preserved well in a tin box. I shall describe the manner of using marine glue and the different cements I have alluded to in §§ 116, 123.

**93. Cement for attaching Gutta Percha or India-rubber to the Glass Slides.**—A cement for attaching cells of gutta percha or India-rubber to the glass slide may be made as follows:—According to Harting, gutta percha is to be cut into very small pieces and stirred, at a gentle heat, with fifteen parts of oil of turpentine; the gritty, insoluble matter, which the gutta percha always contains, is to be separated by straining through linen cloth, and then one part of shell-lac is to be added to the solution, kept at a gentle heat, and occasionally stirred. The mixture is to be kept hot until a drop, when allowed to fall upon a cool surface, becomes tolerably hard. When required for use, the mixture is to be heated, and a small quantity placed upon the slide upon which the cell is to be fixed; the slide itself is then to be heated.

**94. Canada Balsam**, a thick viscid oleo-resin, which becomes softer on the application of a gentle heat, is much employed by microscopical observers: formerly it was used for cementing cells together, but this is now effected more readily by the aid of marine glue. If it be exposed to too high a temperature, the volatile oil is expelled, and a hard brittle resin remains behind. It is chiefly employed for mounting hard dense textures; and, in consequence of its great power of penetrating, and its highly refracting properties, the structure of many substances, which cannot be made out by the ordinary mode of examination, is rendered manifest by this medium. Canada balsam should be preserved in a tin box, pl. XX, fig. 127, care being taken to exclude the dust; or in a bottle having a cap to it. The balsam should be kept very clean, otherwise preparations mounted in it will be spoilt in consequence of the accidental introduction of foreign bodies. It has been frequently recommended that the oldest specimens of balsam should alone be employed for microscopical examination. By exposure to the air, the balsam becomes very thick, and unfit for use: it may be thinned by the addition of turpentine, ether, or chloroform. Turpentine is apt to render the balsam liable to become streaky some time after the preparation has been mounted, and bubbles are often found in it.

*Vessels for Keeping Canada Balsam in.*—The tubes, made of thick tin-foil, used for artists' colours, with a small cap that screws on to the top, as suggested by Mr. Suffolk, are very convenient receptacles for the preservation of Canada balsam. As they contain no space for air, the balsam does not become hard and unmanageable, as is too often the case when it is kept in bottles or tin pots. There is no necessity for using a glass or metal rod, as the quantity of balsam required can always be forced out without the slightest difficulty. Other cements and varnishes can be kept in the tin tubes also for any length of time. It is as well, however, to keep them in an upright position, to prevent the cement from running into the thread of the screw, and so fixing the top too tightly.

Dr. Carpenter recommends a small syringe which is easily filled with the balsam when fluid. A drop can always be obtained by gently warming the end of the syringe, and applying pressure to the piston. By this plan the balsam is kept perfectly clean and free from dust.

**95. Solutions of Canada Balsam.**—Canada balsam is soluble in ether, but its best solvent is chloroform. Many very delicate structures may be mounted in Canada balsam, by immersing them in a chloroform solution. Sufficient chloroform is added to make



the mixture run freely. The balsam becomes more viscid and gradually gets hard as the chloroform evaporates. Solutions of Canada balsam in chloroform are now much used for mounting insects, tissues, and various objects.

Mr. Hepworth, of Croft's Bank, was among the first to use a solution of Canada balsam in chloroform for mounting objects. Mr. W. H. Heys (*Trans. Mic. Soc.*, Jan. 1865, p. 19) prepares the solution as follows. Old balsam is mixed with sufficient chloroform to make it quite fluid so that it will drop easily from the lip of the vessel containing it. The prepared balsam is then poured into long thin half-ounce phials, corked up, and set aside for at least a month. The balsam thus prepared is clearer and sets much quicker than it mixed with the chloroform at the time it is required for use.

**96. Arrangements for pressing down the Thin Glass Cover while the Balsam or Cement is becoming hard**—Some elastic specimens immersed in Canada balsam, gelatin, and other media require firm pressure to be kept up until the balsam or the cement which attaches them to the slide, hardens. Many substances immersed in fluids may be rendered thinner and more transparent if subjected to moderate, but sustained pressure, while the cement which fixes down the thin glass cover is becoming dry and hard. Others require very firm pressure while the process of drying is proceeding. Several methods have been devised for producing pressure. A very simple plan is to place a small piece of wood, about an inch in height, upon the cover. This may be fixed in its place by passing a piece of thread over it, and tying it at the back of the slide; or the wood may be kept in its place by a vulcanized India-rubber ring. Ordinary weights may be used, or springs arranged as in the ingenious apparatus devised by Mr. Gorham. My friend Mr. White has also suggested a very simple and effective apparatus for the same purpose. It consists of a bent lever, which, by acting upon a screw, can be forced down upon the thin glass with the amount of pressure required. Another form of instrument, with a graduated spring, was designed by the Rev. G. Isbell, pl. XX, fig. 128. The compressorium may also be employed for the same purpose, if a small piece of cork be inserted between the thin glass to which the pressure is to be applied, and the glass of the compressorium itself.

Mr. Hoblyn, of Bath (*Archives of Medicine*, vol. III, p. 140), has also invented an ingenious arrangement. In this instrument, a number of slides may be placed at the same time, and a graduated pressure exerted upon them, pl. XVI, fig. 96.

The above pieces of apparatus have however been superseded

by the use of the simple spring clip devised by Dr. Maddox (*Trans. Mic. Soc.*, July, 1865, p. 84). This is made by bending a piece of brass wire in the form represented in pl. XVI, fig. 89. The end which is to press upon the thin glass must be filed perfectly flat, or a piece of flat cork may be fixed to it. Or, in cases where the glass cover is very thin, a smaller piece of thicker glass may be placed upon it and the spring allowed to press upon the latter. This clip has been modified by Mr. Webb, as represented in fig. 90. These clips may be obtained at 1s. 6d. and 2s. per dozen of Mr. Baker, Holborn, and of Mr. Highley, Green Street, Leicester Square.

**97. Gum.**—Thick gum-water will be found very useful for attaching labels to preparations, and also for fixing on the cover when preparations are mounted in the dry way. It is prepared by placing common gum-arabic in cold water, and keeping the bottle in a warm place until the solution has become sufficiently thick. It should always be strained before it is placed in the bottle for use.

Gum-water, thickened with powdered starch or whiting, is a very useful cement for fixing the glass cover on preparations mounted dry. When dry it forms a hard white coating. The addition of a little arsenious acid will prevent the growth of mildew. Another very convenient solution is made by dissolving powdered gum in a weak solution of acetic acid.

**98. French Cement composed of Lime and India-rubber.**—The French cement composed of lime and India-rubber is very valuable for mounting all large microscopical preparations. The principal advantages are, that it never becomes perfectly hard, and it therefore permits considerable alteration to take place in the fluid contained in the cell without the entrance of air. It also adheres very intimately to glass, even if it be perfectly smooth and unground. Suppose a glass cover is to be attached to a large cell containing fluid. A small piece of the cement is taken between the finger and thumb and carefully rolled round until it can be drawn out into a thread about the eighth or tenth of an inch in thickness. I apply this to the top of the cell, before introducing any fluid, and slightly press it down with the finger previously moistened. It adheres intimately. The preservative fluid with the preparation are now introduced and the cell filled with fluid which indeed is allowed to rise up slightly above its walls. The glass cover, cut rather smaller than the external dimensions of the cell, and slightly roughened at the edges, is to be gently breathed upon, and then one edge is applied to the cement, so that it may be allowed to fall gradually upon the surface of the fluid which is now seen to wet each part of the cover successively, until it com-

pletely covers the cell, and a certain quantity of the superfluous fluid is pressed out. By the aid of any pointed instrument a very little cement is removed from one part, so that more fluid may escape as the cover is pressed down gently into the cement. The pressure must be removed very gradually, or air, of course, will enter through the hole. A bubble of air entering in this manner may often be expelled again by pressure, or it may be driven out by forcing in more fluid through a very fine syringe at another part of the cell; but it is far better to prevent the entrance of air in the first instance. The edge of the glass cover being thoroughly embedded in the cement, the small hole is to be carefully plugged up with a small piece of cement, and the cell allowed to stand perfectly still for a short time, when it may be very gently wiped with a soft cloth. The edges of the cement may be smoothed by the application of a warm iron wire, and any superabundance removed with a sharp knife. A little Brunswick black or other liquid cement may be applied to the edges, for the purpose of giving the whole a neater appearance.

The cement is made as follows:—A certain quantity of India-rubber scraps is carefully melted over a slow fire in a covered iron pot. The mass must not be permitted to catch light. When it is quite fluid, lime, in a perfectly fine powder, having been slacked by exposure to the air, is to be added by small quantities at a time, the mixture being well stirred. When moderately thick, it is removed from the fire and well beaten in a mortar and moulded in the hands until of the consistency of putty. It may be coloured by the addition of vermilion or other colouring matter. I have several preparations which have been placed in the creosote and naphtha solution in large cells, and they are now perfectly air-tight, although upwards of twenty years have elapsed since they were first put up. The lime and India-rubber cement answers well for fixing on the glass tops of large preparation jars, and looks very neat; but, if moderately strong spirit be used, a little air must be permitted to remain in the jar.

#### PRESERVATIVE FLUIDS.

In all cases an object to be mounted in a preservative fluid should be soaked in a considerable quantity of it for at least a day before it is mounted permanently, and if the specimen is large, it should be soaked for many days previous to being finally placed in the cell.

**99. Spirit and Water.**—Spirit and water form a well-known and valuable medium for preserving anatomical preparations. In diluting spirit, distilled water only should be employed; for if common

water be mixed with spirit, a precipitation of some of the salts dissolved in it not unfrequently takes place, which renders the mixture turbid and unfit for use. Proof spirit will be strong enough for all general purposes, except for hardening portions of the brain or nervous system, when stronger spirit must be used. Two parts of rectified spirit, about sp. gr. '837, mixed with one part of pure water, make a mixture of sp. gr. '913-'920, which contains about 49 per cent. of real alcohol, and will therefore be about the strength of proof spirit. One part of alcohol, sixty over proof, to five parts of water, forms a mixture of sufficient strength for the preservation of many substances, and not a few microscopical specimens may be preserved in a solution more diluted than this. For some years past, the Government has permitted the use of methylated alcohol for various purposes in the arts, which pays no duty. This spirit answers well for preserving anatomical preparations, and is a great boon to all engaged in putting up large anatomical specimens. It may be obtained at the price of 5s. 6*d.* a gallon, sixty degrees over proof, of Messrs. Lightly and Simon, and of other distillers, in quantities of not less than ten gallons at a time. In the first instance, application must be made to the Board of Inland Revenue, Somerset House, for permission to use the spirit, by letter, accompanied with the names of two respectable householders, who are willing to act as bond that the applicant only uses it for the purposes stated in his application. The probable quantity required annually must also be stated.

**100. Glycerine.**—This is one of the most valuable fluids ever employed for microscopical purposes. I believe Mr. Warrington, of Apothecaries' Hall, was the first observer who used this medium as a preservative fluid for microscopical preparations.

A solution of glycerine adapted for preserving many structures is prepared by mixing equal parts of glycerine with camphor water. The latter prevents the tendency to mildew, or it may be mixed with naphtha and water, or with the creosote solution to be described presently. The degree of dilution will depend upon the nature of specimen. If the substance be at all opaque it will be necessary to employ strong glycerine. I have many preparations which have been preserved in glycerine for nearly twenty years. Of the importance of strong glycerine as a preservative medium, I shall have to speak more fully in part V. Glycerine may be mixed with various chemical tests and preservative substances, for special enquiries, and analyses may be conducted by the test substances being dissolved in this menstruum instead of in water. For preserving medusæ and delicate marine animals Dr. Carpenter recommends a solution composed of *sea water* with one-tenth of *alcohol* and the same quantity of glycerine.

Dr. Maddox tells me that for some years past he has been in the habit of using equal parts of sweet spirits of nitre (Sp. Eth. Nit. of the Pharmacopœia) and glycerine, especially in preparing delicate tissues of insects. He finds that many objects are rendered very transparent if washed in this medium, before they are preserved in glycerine.

Glycerine used to be obtained by boiling oil with litharge. The oleate of lead remains as an insoluble plaster, while the glycerine is dissolved. It may be rendered free from lead by passing a current of sulphuretted hydrogen through it; and the clear solution, after filtration, may then be evaporated to the consistence of a syrup.

The glycerine which is now distilled by a patent process, and known as Price's glycerine, is much superior to the ordinary glycerine. It is perfectly colourless, free from all impurities, and of much greater density. The specific gravity of Price's patent glycerine is 1.240, while the common is only 1.1966. The former costs about 4s. and the latter 1s. 6d. a pound.

For more than fifteen years I have used glycerine for preserving almost every structure. I shall give the results of my most recent experience of this substance, from the use of which I have learnt more than from any other preservative medium, in part V, where also the advantages of glycerine are discussed.

**101. Thwaites' Fluid.**—This fluid has been much employed by Mr. Thwaites for preserving recent specimens of desmidia; but it is also applicable to the preservation of a vast number of animal substances.

It is made as follows:—

Water	. . . . .	16 ounces.
Spirits of wine	. . . . .	1 ounce.
Creosote,	sufficient to saturate the spirit.	
Chalk,	as much as may be necessary.	

Mix the creosote and spirit, stir in the chalk with the aid of a pestle and mortar, and let the water be added gradually. Next add an equal quantity of water saturated with camphor. Allow the mixture to stand for a few days and filter. In attempting to preserve large preparations in this fluid, I found that it always became turbid, and therefore was led to try several modifications of it. The solution next to be described was found to answer very satisfactorily.

Water may also be impregnated with creosote by distillation. It should be remarked that M. Strausdurkheim has succeeded in preserving animal preparations in camphor water only.

**102. Solution of Naphtha and Creosote:—**

Creosote ...	...	...	3 drachms.
Wood naphtha ...	...	...	6 ounces.
Distilled water ...	...	...	64 ounces.
Chalk, as much as may be necessary.			

Mix first the naphtha and creosote, then add as much prepared chalk as may be sufficient to form a thick smooth paste; afterwards add, very gradually, a small quantity of the water, which must be well mixed with the other ingredients in a mortar. Add two or three small lumps of camphor, and allow the mixture to stand in a lightly covered vessel for a fortnight or three weeks, with occasional stirring. The almost clear supernatant fluid may then be poured off and filtered if necessary. It should be kept in well-corked or stoppered bottles.

I have some large preparations which have been preserved in upwards of a pint of this fluid, for nearly twenty years, and the fluid is now perfectly clear and colourless. Some dissections of the nervous systems of insects have kept excellently; the nerves retain their white appearance, and have not become at all brittle. Two or three morbid specimens are also in an excellent state of preservation, the colour being to a great extent preserved, and the soft character of the texture remaining. I have one preparation mounted in a large gutta-percha cell, containing nearly a gallon of this fluid.

A solution of wood naphtha or pyroacetic spirit in water, has been recommended by Professor Quekett, and forms an excellent preservative solution, in the proportion of one part of the naphtha to ten of water. The solution is often a little cloudy, but may be made quite clear by filtration after the mixture has been allowed to stand still for some days.

One great advantage of these aqueous preservative solutions is that the natural appearance of the structure is very slightly altered. The solution, however, after a time renders many of the more delicate structures more or less granular.

**103. Carbolic Acid.**—A solution of carbolic acid in distilled water also preserves many animal and vegetable preparations exceedingly well. The water will only take up a very small quantity, but the preservative properties of the weakest solution are very great. One part of carbolic acid to a hundred of water is sufficient. Carbolic acid may be obtained perfectly pure in a crystalline state of Messrs. Hopkins and Williams, New Cavendish Street.

**104. Solution of Chromic Acid.**—A solution of chromic acid is well adapted for preserving many microscopical specimens. It is

particularly useful for hardening portions of the nervous system previous to cutting thin sections. The solution is prepared by dissolving sufficient of the crystallized acid in distilled water to render the liquid of a pale straw colour.

The crystallized acid may be prepared by decomposing 100 measures of a saturated solution of bichromate of potassa, by the addition of 120 to 150 measures of pure concentrated sulphuric acid. As the mixture becomes cool, crystals of chromic acid are deposited, which should be dried and well pressed on a porous tile, by which means the greater part of the sulphuric acid is removed, and the crystals obtained nearly pure.

**105. Preservative Gelatine.**—This substance was first employed for preserving microscopical textures by Mr. H. Deane, who gives the following directions for its preparation :—

Gelatine ...	...	...	...	1 ounce.
Honey ...	...	...	...	4 ounces.
Spirits of wine ...	...	...	...	$\frac{1}{2}$ ounce.
Creosote ...	...	...	...	6 drops.

Soak the gelatine in water until soft, and to it add the honey which has been previously raised to the boiling-point in another vessel. Next, let the mixture be boiled, and after it has cooled somewhat, the creosote dissolved in the spirits of wine is to be added. Lastly, filter through thick flannel to clarify it.

When required for use, the bottle containing the mixture must be slightly warmed, and a drop placed on the preparation upon the glass slide, which should also be warmed a little. Next, the glass cover, after having been breathed upon, is to be laid on with the usual precautions. The edges may be covered with a coating of the Brunswick black varnish. Care must be taken that the surface of the drop does not become dry before the application of the glass cover ; and the inclusion of air-bubbles must be carefully avoided.

**106. Gelatine and Glycerine.**—A mixture of gelatine and glycerine makes a very valuable medium for preserving different animal and vegetable structures.

The mixture may be made as follows :—A certain quantity of gelatine or isinglass is allowed to soak for some time in cold water, until it swells up and becomes soft. It is then placed in a glass vessel and melted by the heat of warm water. It may be clarified if necessary, by first adding to the cool gelatine a little white of egg, then boiling the mixture, and filtering through fine flannel. To this fluid, an equal quantity of strong glycerine is added and well mixed with it. This mixture may be kept for any length of time, and a

very slight heat is sufficient to render it perfectly fluid. The gelatine and glycerine, prepared by Mr. Rimmington, operative chemist, of Bradford, is the best medium of the kind I have used. It may be obtained by small bottles free by post for 1s. 4d.

**107. Gum and Glycerine.**—Mr. Farrants has suggested the following valuable preservative medium which will be found most useful for mounting very many objects :—

Picked gum-arabic ..	...	...	4 ounces by weight.
Distilled water ..	...	...	4 „ „
Glycerine ..	...	...	2 „ „

It is to be kept in a stoppered bottle and a piece of camphor added to the solution.

**108. Goadby's Solution.**—This is made of several different strengths. That most generally useful is the following :—

Bay salt ...	...	...	...	4 ounces.
Alum ...	...	...	...	2 ounces.
Corrosive sublimate.	...	...	...	4 grains.
Boiling water	...	...	...	4 pints.

Mix and filter. This solution for most purposes may be diluted with an equal bulk of water. For preserving delicate preparations it should be even still more dilute. Goadby's solution is very valuable for preserving many anatomical specimens, but as it tends to render tissues hard and opaque, is not adapted for the preservation of many structures which are to be examined in the microscope.

**109. Burnett's Solution,** consisting of chloride of zinc, is a powerful antiseptic, but not adapted for the preservation of microscopical specimens.

**110. Chloride of Calcium.**—A saturated aqueous solution of chloride of calcium, free from iron, has been much recommended for preserving specimens of bone, hair, teeth, and other hard structures, as well as many vegetable tissues. A solution of chloride of calcium has been used by the late Professor Schröder Van der Kolk, of Utrecht, for keeping sections of the spinal cord and preparations of nerves. Many of these, through the kindness of my friend, I have had an opportunity of seeing and can testify to their excellence.

**111. Alum and other Salts.**—A solution of *alum* in the proportion of one part of alum to sixteen of water has been found to answer pretty well for some substances. Gannal's solution, which consists of one part of *acetate of alumina* dissolved in ten parts of water; solutions of *common salt* (one part to five of water, with a



little camphor), *corrosive sublimate*, *persulphate of iron*, *sulphate of zinc*, and solutions of several other salts, have been recommended as preservative solutions, but although adapted for the preservation of animal substances, they cannot be employed for microscopical specimens, in consequence of their tendency to render the textures very opaque and granular. Mr. A. E. Verrill (*Siliman's Journal*, March 1865) recommends a solution made with nitre, rock salt, and arseniate of potassa. My own experience, however, has led me to discard all solutions containing salts for microscopical purposes.

**112. Arsenious Acid** has been much recommended, and Dr. Andrew Clarke has preserved many specimens of lung tissue and other structures in an aqueous solution of this substance.

**113. Arseniuretted hydrogen** gas has also been recommended for the preservation of animal substances, but it is not adapted for microscopical preparations. Dr. Richardson has lately kept animal substances from decomposition by immersing them in an atmosphere of *nitrogen*, which is prepared by placing a piece of phosphorus in a stone jar containing common air, and provided with an air-tight cover. The oxygen is soon exhausted, and no decomposition can take place.

Most of the preservative solutions which I have referred to may be obtained of Mr. Highley, Green Street, Leicester Square. The mode of using them will be described further on. Every microscopist engaged in any special enquiry will of course alter the composition of these solutions in any way experiment may show to be advisable. Great improvements doubtless may yet be made in many preservative solutions. A series of exact experiments of the effects of the different fluids upon the same textures is much to be desired, and this is one of the questions upon which amateurs might contribute most valuable information.

#### CELLS FOR PRESERVING MICROSCOPICAL SPECIMENS.

All objects intended for microscopical observation should be protected with a cover of thin glass. This cover prevents the entrance of dust, and protects the object from exposure to the atmosphere. The fluid in which many objects are placed for examination would rise in vapour which would condense upon the object-glass, and give rise to great inconvenience were it not prevented from evaporating by a thin glass cover. If the thin glass, however, should press upon the object placed upon the glass slide, its distinctness would in many cases be impaired, or the structure might be entirely destroyed—an inconvenience which may be prevented by placing some insoluble sub-

stance slightly thicker than the object with it between the glasses. A little cavity may be made in many ways in which a specimen, dry or with its preservative fluid, may be placed, and afterwards covered with thin glass without risk of injury from pressure. This is termed a cell.

Cells may be composed of various materials according to the thickness which may be necessary, and according to the nature of the substance to be placed within them.

**114. Paper Cells.**—For *dry objects* an efficient cell is readily made with a ring of paper or cardboard fixed with gum to the glass slide; or a hole may be punched out of a piece of cardboard, wood, mill-board, or gutta percha, or a vulcanized India-rubber ring may be cemented to a slip of glass. Many other devices will occur to the mind of any one who wishes to make neat cells of this kind. If, however, the cell is intended to contain fluid, it must be made of some substance impervious to moisture.

**115. Shell-lac Cells.**—Dr. Maddox recommends Bell's cement thickened with crushed shell-lac dissolved in a very small quantity of methylated spirit for making thin cells.

The clean slide is warmed and placed on the "turn-table," § 116, pl. XVI, fig. 91; a *full brush* of the thickened cement is then made to strike a circle. The slide is held over the spirit lamp until bubbles are given off, when it is placed horizontally on a warm surface to dry; when *nearly set hard* it is removed, allowed to cool a little, and a piece of thick plate glass, previously wetted, is pressed carefully on the circle of cement until fastened equally. These cells can be kept ready for use of various thicknesses. If the object be mounted in glycerine in one of these cells, and is not likely to be injured by a slight heat, it is best after placing down the thin cover and cleaning the edges carefully, to gently warm the slide and press the cover equally on the cement. If properly managed the cover generally adheres to the cement, and after being cemented with a *thinner* solution of the same cementing medium forms an excellent close cell for glycerine.

**116. Brunswick Black Cell.**—A very thin cell may be made by painting a ring of Brunswick black or gold size upon the glass slide, and then allowing it to dry.

The best form of Brunswick black cell is the circular one, which is so easily made by the aid of Mr. Shadbolt's excellent turn-table, pl. XVI, fig. 91. The slide is placed on the little brass wheel which is made to revolve, while a brushful of Brunswick black is held at the proper distance from the centre, according to the diameter of the cell required. If a thick layer is desired the slide may be warmed, when the layers of Brunswick black applied, dry very quickly.

**117. Marine Glue Cells** may be made according to the same plan. In order to make such a cell, a glass slide is warmed upon the brass plate, § 72, and when hot enough a small piece is allowed to melt upon the slide, and moved round and round in the position in which the wall of the cell is to be. When the glue has been allowed to cool, any superfluity may be removed from the slide with a sharp knife. The surface may be made level by rubbing it gently upon a piece of emery paper laid on a plate glass or other perfectly flat surface.

**118. Cells made of Tinfoil.**—A piece of tinfoil may be cut out, so as to form a slightly thicker cell, and may be fixed upon the slide with marine glue, as in fig. 102, pl. XVII. Tin cells are now made of every thickness by Mr. Collins, Titchfield Street. They form the cheapest kind of cell.

### *Of Glass Cells.*

**119. Cutting and Grinding Glass.**—In the manufacture of cells presently to be described, glass is required to be cut with a diamond and ground perfectly smooth at the edges. Moderately thick glass is cut with the ordinary glazier's diamond, pl. XVI, fig. 92, but when we require to cut plate glass, a larger diamond than that in ordinary use is necessary.

The *thin glass* is cut with the writing diamond, pl. XVI, fig. 94, which makes a scratch sufficiently deep to permit of the glass being broken off very smoothly. The *circles* of thin glass may be cut by carrying the diamond round openings which have been turned in pieces of brass. Of these many different sizes may be made so that circular pieces of thin glass of any required diameter, may be easily cut, fig. 95, pl. XVI.

**120. Stone for Grinding.**—Glass can be *ground* upon a perfectly *flat stone* with emery powder or fine sand and a little water, or, instead of the stone, a flat *plate* composed of pewter may be used, as was recommended by Dr. Goadby. The emery after a time becomes embedded in the pewter, and thus a very efficient surface for grinding results.

The pewter plate may be cast in the form of a flat circular disk, which can be placed upon a pivot and made to revolve rapidly in a horizontal direction by means of a multiplying winch connected with it—an arrangement which is desirable when it is important to save labour as much as possible.

**121. Of Drilling Holes in Glass.**—In the construction of many forms of cells it is necessary to drill holes through thick glass. This

may be effected with an ordinary sharp-pointed file if the end be moistened from time to time with a little turpentine. The operation is of course more quickly performed with a drill, the point of which has been rendered very hard.

**122. Cementing Glass together with Marine Glue.**—The surface of glass to which a cement is to be applied should always be roughened by grinding, as the cement adheres much more intimately to a rough surface than to the polished glass.

Glass is cemented together with marine glue, and in making large built glass cells, the edges are united by means of the same substance, which can now be readily obtained. Formerly gold size, Canada balsam, and other cements were employed, but these are all inferior to marine glue.

The manner of applying the marine glue to the glass has been already alluded to. The glass must always be warmed upon a flat brass or iron plate, so that the heat may be applied gradually and equally. It must not be touched with cold fingers, but must be held with wooden forceps, or with ordinary forceps, the extremities of which have been protected with pieces of cork, in the manner described in § 82.

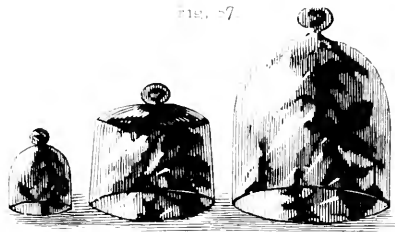
When the pieces of glass of which the cell is to be composed are warm enough, a little glue cut into small pieces is allowed to melt in the position in which the glass is to be fixed. When it is melted, the glass is applied and pressed down upon a deal board, so as to squeeze out as much marine glue as possible and make a good joint.

The student should make for himself a plate-glass stage. A piece of thin plate glass is cut about four inches by two. The edges are to be ground smooth and a narrow strip of glass cemented to one edge with marine glue. This is to support the ordinary glass slide. A glass stage of this description protects the microscope, especially when acids or corrosive fluids are used, fig. 97, pl. XVII.

**123. Cleaning off Superfluous Glue.**—While the slide is yet warm, much of the glue may be scraped off with an old knife and small chisel, pl. XVI, fig. 93, after which a little *solution of potash* (the *liquor potassæ* of the shops) will soften the remainder. It may then be very readily removed with the aid of soap and water and a nail brush. Or the whole cell may be soaked in equal parts of liquor potassæ and water,—but we must bear in mind that if the cell be soaked for too long a time in strong solution of potash, there is danger of the glue between the glass being softened. The potash must always be carefully washed away, to prevent the chance of the glue being softened after the cell is complete.

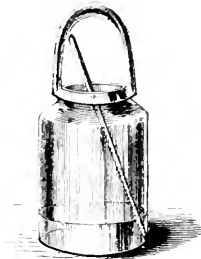
**124. Cells made of Thin Glass.**—The neatest and most perfect

Fig. 87.



Glass shades for protecting objects from dust while being mounted. p. 47.

Fig. 88.



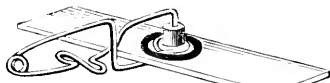
Vessel for containing Canada balsam and other elements. p. 47.

Fig. 89.



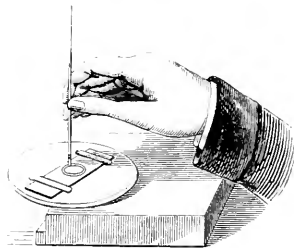
Fig. Maddox's spring clip. p. 50.

Fig. 90.



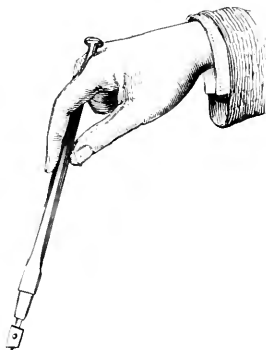
Modified spring clip. p. 50.

Fig. 91.



Stadler's apparatus for making fine lines of Prussian blue. p. 60.

Fig. 92.



To illustrate the manner in which the diamond is used for cutting thick glass. p. 61.

Fig. 93.



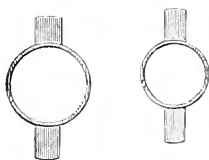
Large bradawl, for scraping away superfluous marine glue in making cells. p. 62.

Fig. 94.



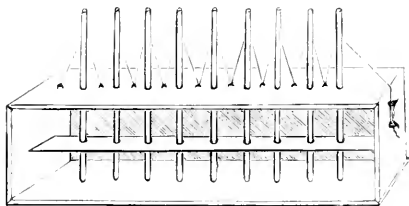
Writing diamond, for cutting thin glass. p. 61.

Fig. 95.



Flat brass rings for cutting circles of thin glass. p. 61.

Fig. 96.



Arrangement for exerting continued pressure upon the glass covers of some specimens while the cement is drying. p. 61.



*shallow cell* is formed by making a hole of the required size in a piece of thin glass. This used to be effected as follows:—Many pieces of thin glass were glued together with marine glue, and when cold a hole was drilled through them all. Lastly they were separated from each other by heat, and cleaned with potash in the usual manner.

**125. Simple Methods of Perforating the Thin Glass.**—Thin glass cells may, however, be readily made by every microscopist for himself, according to either of the following plans:—My friend, Dr. Frere, takes a small piece of thin glass, and with the writing diamond scratches a line corresponding to the piece of glass he wishes to remove, next a bradawl or other sharp instrument is placed in the centre of the space, the glass being laid upon a perfectly flat surface, such as thick plate glass. A sharp tap upon the bradawl with a light hammer causes it to perforate the glass, but the cracks made in it do not extend beyond the line marked with the diamond. The fragments of glass are then carefully removed piecemeal with a pair of fine forceps, and the cell is complete. In many cases, however, the cracks do pass beyond the line, and thus the chance of removing the fragments from the centre is much diminished.

The method which I have been in the habit of employing for some years is this: I cement a square or circle of thin glass with marine glue to one of the circular or quadrangular rings of glass used for making deep glass cells, and alluded to in § 127; the hole in the centre being the exact size of that required to be made in the thin glass, pl. XVII, fig. 99. When the marine glue is cold, a file is forced through the centre of the thin glass. The cracks thus produced do not run across that part of the glass cemented by the marine glue. The edges may then be filed square, and the thin glass only requires to be warmed in order to remove it from the cell. It may now be fixed upon the slide at once, or cleaned with potash and kept with others until required to be made into a cell.

In order to perforate the thin glass in making thin glass cells, Mr. Brooke takes two firm brass rings, ground perfectly flat, the diameter of one being a trifle less than that of the other. The piece of thin glass to be perforated is firmly pressed between them, and the writing diamond carried round so as to scratch each surface. The circular piece is then removed by a slight tap upon the surface on which the smallest circle has been scratched.

**126. Deeper Glass Cells.**—Supposing a cell a little deeper than any of the above is wanted we may proceed in a different manner, vpl. XVII, fig. 100; a piece of plate glass of the proper thickness is to be cut with the diamond to correspond with the outside of the

cell, next, from each side of this piece of glass, a strip of the required width is to be removed, and from its ends, corresponding strips are to be cut off. The central portion is taken away, and the strips thus cut out are *inverted* upon the slide upon which they are to be fixed with marine glue, care being taken to mark them in the first instance, so that they may correspond properly with each other. The marine glue is allowed to run well into all the corners. In this way a capital cell is very easily and quickly made. Cells of various sizes and depths can be manufactured upon this principle. The surface of the glass rim should be ground upon the stone, and the superfluous glue removed in the ordinary manner.

**127. Small Deep Cells for Injections.**—By drilling a hole in a piece of plate glass, by cutting off sections of various thickness from thick glass tubing, or from thick square glass bottles, or from vessels moulded for the purpose,—excellent cells of various dimensions, and admirably adapted for mounting injections and other purposes, are made; but when the preparation is of considerable thickness, deeper cells than any of those to which I have alluded will be required. These may be made in glass, gutta percha, and some other substances. A *round* or *oval concavity* may be ground upon the surface of a piece of very thick plate glass. Different forms of small deep glass cells are represented in pl. XVII, figs. 101 to 105. Moderately deep glass cells may be made also by grinding holes of the size required through thick plate glass, fig. 105.

**128. Built Glass Cells** are those which are constructed by joining together, at the edges and ends, separate pieces of glass with marine glue or some other cement. The simplest form of built glass cell has been already described.

Good cells may be made from thick plate glass, the edges of which have been ground perfectly flat before they were united with the marine glue. Dr. Goadby used to make many of these cells, upon this principle of very large dimensions. They may be obtained of Mr. Dennis, of St. John's Street Road, who has succeeded in making plate glass boxes in this manner large enough to hold several quarts of fluid. Many cells of this description may be seen in the Hunterian Museum of the Royal College of Surgeons. They may be constructed as follows:—A strip of plate glass is cut off, of the proper height for the sides of the cell. From this, two pieces are to be cut off the desired length of the sides, and two pieces for the ends. The flat surface of these are to be cemented with marine glue, and all the edges ground perfectly flat together. The ends are also to be very carefully ground square. They are then to be separated by heat and connected together at the corners in the proper position, pl. XVIII,

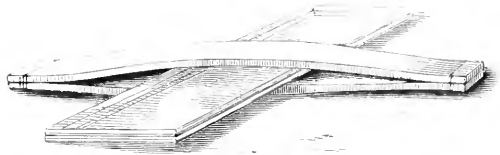


Fig. 97.



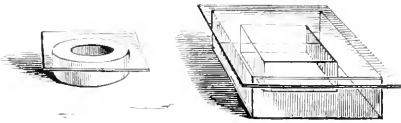
Thin glass slide for examining objects ten times, in a field of view of moderate diameter. p. 62.

Fig. 98.



Holder, constructed of two pieces of wood, one flat, the other bent to hold the slide, or riveted at both ends. p. 62.

Fig. 99.



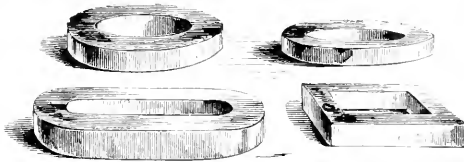
Small circular glass cell for examining objects ten times, in a field of view of moderate diameter. p. 62.

Fig. 100.



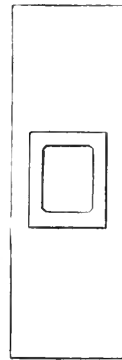
Illustrates a simple way of making a moderately thick glass cell. p. 62.

Fig. 101.



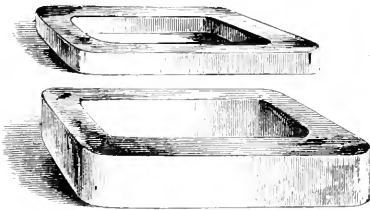
Small cells for preserving injections and other thin preparations. p. 61.

Fig. 102.



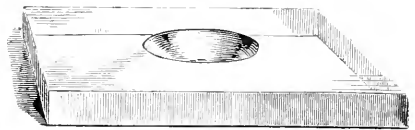
Thin glass cell for examining injections ten times. p. 63.

Fig. 103.



Large deep glass cells for preserving of injections. p. 64.

Fig. 104.



Concave glass cell, made by grinding out a cup-shaped cavity in the surface of a piece of very thick glass, and afterwards polished. p. 64.

Fig. 105.



Concave glass cell, made by grinding out a portion of plate glass. p. 64.



fig. 108. When the four sides have been thus joined together, one surface is to be carefully ground flat, and then cemented to the plate-glass bottom. The other side, on which the cover is to be placed, may be ground flat afterwards. In order to increase the strength of these cells and to diminish the chance of leakage, it is well to cement small pieces of glass in the corners, and narrow strips outside, where the sides are attached to the glass slab, pl. XVIII, fig. 109.

These cells, of course, take some time to make, but they are exceedingly neat, and have but one serious drawback—a slight liability to leak, which is hardly to be wondered at when the number of the joinings is taken into consideration.

**129. Deep Glass Cells made by bending a strip of Glass in the blow-pipe flame.**—For some years past I have been in the habit of bending a long strip of glass in the blow-pipe flame, and cementing the extremities together in a similar manner whenever a cell of about half an inch in depth is wanted. The ordinary plate glass is very liable to crack as it becomes cool, but if *flatted flint glass* be employed the operation is simple enough. This glass, as well as the deep glass cells above referred to, may be obtained at Messrs. Powell's glass works, Whitefriars. This cell has the disadvantage of not being perfectly clear. If flint glass could be flatted, ground, and polished like plate, it would be of much value to those who mount large objects in deep glass cells, pl. XVIII, fig. 110.

**130. Moulded Glass Cells.**—Of late years moulded glass cells have been much employed for anatomical preparations, and the absence of joints renders them preferable to built glass cells. Large moulded cells are now made in Germany, the sides of which have been ground and polished, and thus a preparation can be seen within, almost as clearly as if the sides were composed of plate glass. These cells can be obtained for a much lower price than the built cells, and are, of course, not so liable to leak. They may be purchased at the glass works, Whitefriars.

**131. Gutta Percha and Ebonite Cells.**—Gutta percha may be moulded in a wooden case, and forms excellent cells where transparent sides are not required. I have several preparations which have been preserved for many years in large cells of this description. Gutta percha is most useful for joining glass tubes to flat cells as may be required in forming cells for special purposes, pl. XVIII, fig. 106.

*Ebonite Cells.*—Excellent cells may be made out of the preparation of India rubber known as vulcanite or ebonite. They may be turned to any size and thickness required. Dr. Maddox used such cells in 1861. Mr. W. H. Hall also strongly recommends these cells.

They may be purchased of Mr. Bailey, of Fenchurch Street, at 6*d.* a-dozen.

**132. Round Cells.**—My friend and colleague, Dr. Guy, has lately proposed a form of cell which possesses many advantages over those in common use. These are circular, and may be made of bone, metal, gutta percha, or glass, of various depths, and to suit transparent and opaque objects. Several forms have been made. They are all of the same external diameter, and are made to fit into a rim of equal size in a flat plate of wood, or metal, which can be placed in the field of the microscope. A small cabinet will contain many more preparations mounted in this manner than on the ordinary slips of glass. Dr. Guy has had some circular labels printed for these cells upon which the names of the preparations may be written, and as these are of different colours the various microscopic objects can be readily classified.

**133. Troughs for Examining Zoophytes.**—These are deep but very narrow glass cells, the two surfaces consisting of very thin glass, so that the higher powers may be brought sufficiently close to the objects. The opening is above, so that the cell with living animals within may be placed upon the stage of the microscope, when the instrument is inclined, without any fluid escaping. It is convenient to have a glass partition in these troughs, by means of which objects may be placed in different parts of the cell. A convenient size is three inches long, an inch and a half deep, and a quarter of an inch in width.

**134. Animalcule Cage.**—Another very convenient form of cell is the one called animalcule cage, pl. VII, fig. 28, pl. XVIII, fig. 112. By means of its sliding cover a stratum of fluid of any required thickness can be obtained, and small living animals can be conveniently fixed in positions suitable for observation. For the examination of deposits in fluids this form of cell is also very convenient.

**135. Growing Cells.**—In many investigations upon the lower forms of vegetables and animals which live in water, it is necessary to watch the same specimen for a considerable time. Some plan must therefore be adopted by which the living object can be freely supplied with fresh water and air. Numerous forms of *growing cells* have been proposed, but I shall only refer to two or three which seem to me to be most advantageous. The following brief description of an improved growing-trough by its ingenious deviser, Prof. Smith, of Kenyon College, United States, is taken from Silliman's American Journal of Science, September, 1865, also Mag. Nat. Hist., vol. XVI, 1865. The whole slide is a trifle more than one-eighth of an inch in thick-

ness. It consists of two rectangular glass plates  $3 \times 2$  in and about  $\frac{1}{25}$  of an inch thick, separated by thin strips of glass of the same thickness, cemented to the interior opposed faces. The upper plate has a small hole drilled through it. One corner of the upper glass is removed, and a small strip of glass, which is cemented to it in the proper place, prevents the thin glass cover placed over the edge from sliding off. To use the slide, fill the space between the two plates with clean water introduced by means of a pipette, and also place a drop in the hole to remove the air. The object being put on the top of the slide, and wetted, is now to be covered with a large square of thin glass, at the same time covering the hole. The slide can now be placed upright, or in any position, as no water can escape. It is, in fact, only a new application of the old principle of the bird-fountain. As the water evaporates from under the cover, more is supplied through the hole, and from time to time an air bubble enters. Thus a constant circulation is maintained.

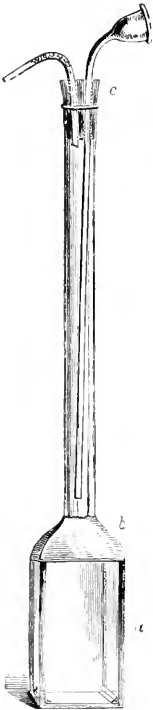
Mr. Richard Beck has made one or two alterations in the growing cell of Professor Smith (Quarterly Journal of Microscopical Science, April, 1856). The annoyance caused by the water line obscuring the view, as sometimes happens in Professor Smith's growing cell, has been entirely obviated, and one or two other improvements have been effected.

Dr. John Barker, of Dublin, has contrived a very convenient, efficient, and cheap growing stage, which has the advantage of allowing the use of the ordinary glass slides. A full description of this will be found in the Quarterly Journal of Microscopical Science, January, 1867. Any one can make this growing stage for himself with very little trouble. A segment of a largish circle is cut in a plate of stout glass to form the stage. To one end of this is attached by means of marine glue, a small flat glass bottle in which two little holes have been drilled. These bottles may be obtained of Mr. Baker, of Holborn. When water is put into the bottle, it is conveyed from one of these holes to the thin glass cover under which the object is to be kept moist, by means of a narrow strip of talc which acts as a conductor for it. By this arrangement, any object under observation may be kept moist for the space of a week, if desirable. Dr. Barker's growing slide is represented in pl. XVIII, fig. III.

For some time past I have been in the habit of employing an arrangement which is simpler than either of those above referred to, and, in my hands at least, it has proved very efficient. A small piece of glass tube is fixed with the aid of marine glue to one end of an ordinary glass slide *a*, fig. III\*, pl. XVIII. This is the reservoir for the

supply of water. It is covered with a piece of thin glass, but a small opening is left at one side sufficient to allow a fine thread of silk or cotton to conduct the water from the reservoir to the specimen placed in the centre of the slide. The stratum of fluid containing the living bodies can be obtained of the required thickness by placing hair or pieces of fine glass rod between the thin glass and the slide. In some cases it is necessary to apply warmth, and keep the bodies under examination at a certain temperature for a considerable time. The method of warming the slide is described in another part of this volume.

Fig. 10.



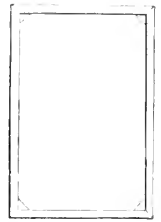
To illustrate the manner in which cells of a peculiar shape may be made. The lower part is made of plate-glass, to which the tube is attached by gutta-percha. This apparatus was made for examining the circulation in the branchiae of a proteus. The smaller tubes were for the purpose of supplying the animal with fresh water. p. 66.

Fig. 107.



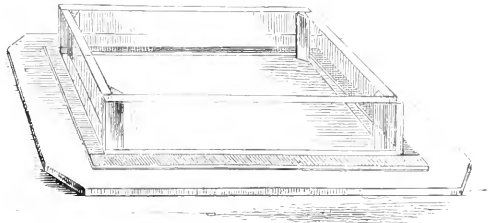
Shows the manner in which the sides of fault glass cells are cemented together in order to be ground perfectly flat. p. 64.

Fig. 108.



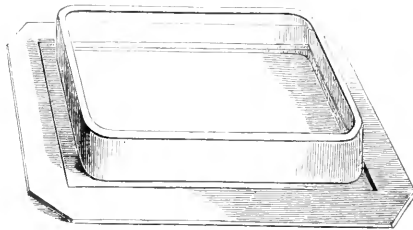
Shows the way in which the angles of a fault glass cell are rounded together. p. 64.

Fig. 109.



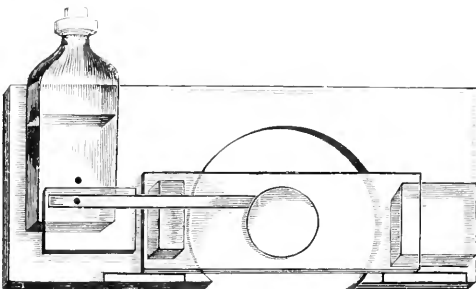
Shallow glass cell. p. 64.

Fig. 110.



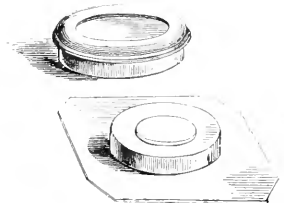
Deep glass cell made by bending a piece of glass in the blowpipe flame. p. 65.

Fig. 111.



Growing cell designed by Dr. Barker. p. 67.

Fig. 112.



Animalcule case for examining deposits from fluids. p. 68.

Fig. 113.



Improved arrangement for conducting water to branchiae of an animal. p. 67.





## PART II.

OF PREPARING AND PRESERVING OBJECTS FOR THE MICROSCOPE—  
SEPARATING DEPOSITS FROM FLUIDS—OF INJECTING—OF DEMONSTRATING THE STRUCTURE OF THE FULLY FORMED TISSUES OF MAN, THE HIGHER AND LOWER ANIMALS, AND PLANTS—OF EXAMINING MINERALS AND FOSSILS.

OF THE IMPORTANCE OF EXAMINING THE SAME OBJECTS IN DIFFERENT MEDIA—AIR, WATER, AND CANADA BALSAM.

Many objects require to be studied in different ways before an accurate idea of their general structure can be formed. It is in many instances of the utmost importance to examine an object by *reflected light* as well as by *transmitted light*, and to observe the peculiarities of structure when it is surrounded with *air*, or immersed in *water*, or in a highly refracting fluid, such as *glycerine*, *oil*, *turpentine*, or *Canada balsam*. Not less valuable is the information we derive from the application of certain *chemical reagents* (part III). The method of investigation must vary according to the degree of *transparency or opacity*, *density*, *refractive power*, and *chemical composition* of the specimen. The object must also be examined first with the aid of low, and afterwards with high magnifying powers.

**136. Appearance of the Same Object examined in Air, Water, and Canada Balsam, by Transmitted Light, and under the Influence of Reflected Light and Polarised Light.**—In pl. XIX specimens of the same structure (spherical crystals of carbonate of lime and octahedra of oxalate of lime) magnified in the same degree, are represented.

*In Air.*—In fig. 113 crystals of carbonate of lime, and in fig. 119 octahedra of oxalate of lime are shown by *transmitted light* in air mounted in the dry way, and it will be noticed how very dark and thick the outer part appears, and how impossible it is to make out the structure of the former crystals.

*In Water.*—In figs. 114 and 120 the same crystals are seen in water. The outer part of the crystals of carbonate of lime is still very dark and thick, but a few lines may be observed radiating from the centre of the crystals towards their circumference, although not very distinctly.

*In Canada Balsam.*—In figs. 115 and 121 the crystals are shown immersed in Canada balsam. The outline now appears as a sharp well-defined line. In the case of the carbonate of lime a number of narrow lines are seen radiating from the centre of each crystal towards its circumference; in fact the crystal really consists of a congeries of minute acicular crystals.

*By Reflected Light.*—In figs. 116 and 118 the crystals are represented as they appear when examined by reflected light. The globular form, and yellowish colour of the carbonate of lime, are very distinctly seen, and the surfaces of the crystals generally seem slightly rough, some appearing to be covered by minute elevations.

*By Polarised Light.*—In fig. 117 another preparation of the crystals of carbonate of lime is seen under the influence of polarised light. Each crystal exhibits a black cross which alters its position and appearance as the *analyser*, p. 18, is rotated.

The above important points might be illustrated by a vast number of other substances. I cannot too strongly advise the observer to subject various microscopical structures to examination in *air*, *water*, and *Canada balsam*, and by *direct* or *reflected*, as well as under the influence of *transmitted light*, and in some cases by *polarised light*.

**137. Of Air Bubbles, Oil Globules, and Globules of Crystalline Matter.**—It is of the utmost importance that the observer should make himself familiar with the appearance of air bubbles and oil globules as soon as possible, for he will often meet with them, and if not acquainted with their characters he may make the most ridiculous mistakes in describing specimens.

*Air Bubbles* in water have a very wide dark outline: indeed, small air bubbles appear like round black spots. This appearance is very characteristic, and every observer ought to be thoroughly familiar with it. Air bubbles of various sizes are represented in pl. XIX, fig. 122.

*Oil Globules* also present a peculiar and well-known appearance. The outline is sharp, and dark, and well defined, but not nearly so wide as that of the air bubble, because the difference of the refractive power between the oil and the fluid, although very great, is much less than that which exists between the air and the fluid medium which contains it. Every one should compare carefully air bubbles with oil globules under the microscope. Oil globules within cells, and free oil globules of various sizes, as seen in milk, are represented in pl. XIX, figs. 123—126. Every observer should be familiar with the microscopical appearance of oil globules of different kinds. Certain kinds of fatty matter contain much crystalline fat, as stearine or margarin, which is not a pure substance. These crystallise

spontaneously from the more oily fatty matters. By the action of acids and other agents many fats are decomposed and the crystalline fatty acids are set free. Many slightly soluble earthy salts crystallise under certain circumstances, especially in mucus and viscous fluids in the form of *globules* or *spherules*, which often closely resemble oil globules, from which they may be distinguished by their hardness and chemical characters. See pl. XIX, fig. 114.

**138. For Beginners only. How to Examine an Object in the Microscope.**—Any one who purchases a microscope probably endeavours to look at some object through it as soon as it comes home, and of those who make such an attempt many fail completely, because they are not acquainted with the principles enunciated in the preceding pages. The observer should go through the tables at the end of the volume; but if too impatient and eager for action, he may proceed to work at once as follows:—

1. Place the microscope in the position represented in fig. 43: pl. X, the eye-piece and the low object-glass (the inch) being adapted to the microscope. Turn the mirror out of the way and permit the dark part of the diaphragm to occupy the field, or place a piece of black paper beneath the aperture.

2. Take a dry bread crumb, about the size of a small pin's head, place it on a glass slide, and the slide upon the stage of the microscope.

3. Place an ordinary wax candle, or French, or other lamp in such a position that the upper surface of the crumb of bread may be lighted up, or use the bull's-eye condenser, so that a strong light is condensed upon the object, as in fig. 43.

4. Screw down the body of the microscope until the object comes into focus and is seen distinctly.

The crumb of bread is examined as an *opaque object by reflected light*, and peculiarities of its surface are alone made out.

5. Alter the position of the lamp, if necessary, and so arrange the mirror that the light may be reflected from it, and caused to pass through the object (transmitted light), fig. 42, pl. X. Prevent the light from illuminating the surface as before. The object seems very dark and little that is definite can be discovered.

6. Break the crumb up into several smaller pieces. This may be easily effected with the aid of a penknife. Most of the particles appear angular. They seem dark because they are too thick for the light to pass through them, but here and there one appears more or less transparent.

7. One of the transparent pieces being in the field, remove the inch power and screw on the quarter of an inch object-glass, and

examine the crumb. Still the appearance is not very definite or satisfactory, and little information is gained with regard to the structure of the crumb or of the nature of its component particles.

8. Next screw up the body of the microscope, and remove the slide from the stage. Carry a drop of water on the tip of one finger, and cause the minute crumbs of bread to be wetted without their position being much altered, and carefully apply one of the pieces of thin covering glass, p. 47, after breathing upon the surface which is to come into contact with the fluid. The thin glass may be held in forceps or between the finger and thumb, and allowed to fall upon the wet crumbs very gradually by using a needle or a knife, as represented in pl. XXII, fig. 142. Remove the superfluous moisture by the aid of the handkerchief, or with a piece of blotting paper, so that no water will drop from the slide when it is placed upon the inclined stage of the microscope.

9. When the crumbs have soaked for a few seconds, give the thin glass two or three smart taps so as to crush them a little and make them spread out.

10. Bring the object as near the centre of the field as possible, and screw down the body of the instrument until the object comes into focus. Many new facts are now learnt.

*a.* A number of small, oval, circular, angular and perfectly transparent particles are seen for the first time.

*b.* The dark indefinite appearance before observed is no longer visible.

*c.* Each transparent particle has a sharp and dark outline. Some are cracked, others exhibit irregularities of surface, while in some an indication of concentric lines may be observed. These bodies are starch granules or corpuscles of various sizes, modified by the heat of the oven. They appear clear and transparent now they are *examined in water*, instead of black and opaque as when they were examined before *in air*, because the refractive power of the water approaches more closely to that of the starch granule than the air.

*d.* Probably some black spherical bodies or very wide and dark circular rings will be observed here and there. These are air bubbles, pl. XIX, fig. 122.

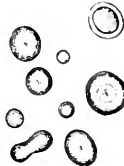
11. Examine the thinnest possible shaving of deal wood or of a cedar pencil, and of mahogany or oak, a fragment of blotting paper, a piece of cotton and linen scraped as fine as possible, a small pinch of flour, ordinary starch, common pepper, cayenne pepper, powdered mustard, in the same way as the bread crumbs, taking care to allow them to soak in a drop of water for an hour or more, so that they may be perfectly wetted.

Fig. 113.



Spherical crystals of carbonate of lime, examined by transmitted light, in air. p. 69.

Fig. 114.



[The same in water. p. 69.]

Fig. 115.



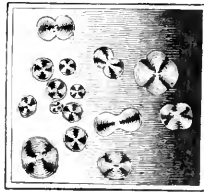
The same in Canada balsam. p. 70.

Fig. 116.



The same viewed by reflected light. p. 70.

Fig. 117.



The same under the influence of polarized light. p. 70.

Fig. 118.



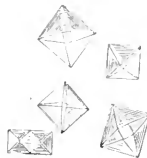
Octahedral crystals as seen by reflected light. p. 70.

Fig. 119.



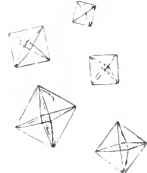
Octahedra in air by transmitted light. p. 69.

Fig. 120.



Octahedra in water. p. 69.

Fig. 121.



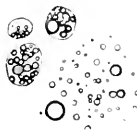
Octahedra in Canada balsam. p. 70.

Fig. 122.



Air bubbles in water. p. 69.

Fig. 123.



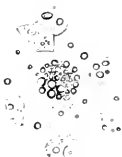
Free oil globules and collections. p. 70.

Fig. 124.



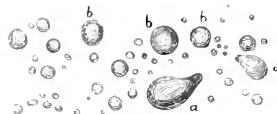
Oil globules. Milk. p. 70.

Fig. 125.



Oil globules in collections, and doublets, containing oil globules. p. 71.

Fig. 126.



Oil globules from milk. a, masses formed by two or more globules running together. p. 71.



12. Subject pieces of moist tea leaves, very thin sections of potato and the peel of the potato, the skin or interior of an orange, lemon or other fruit, a piece of rhubarb, cabbage, or other vegetable, taking care that in all cases the pieces are *small enough*. They can easily be subdivided with a sharp penknife.

I strongly recommend the beginner to examine various specimens of jam and preserved fruits. As these vegetable tissues have long soaked in syrup, they have become exceedingly transparent, and are admirably fitted for microscopical demonstration. The spiral vessels, woody, and cellular tissues, can be obtained without any trouble, and the minute structure of the different vegetable tissues can be most clearly demonstrated.

The thinnest possible sections can be cut with a sharp thin knife, p. 45, from the firmest of these preserved fruits. The specimen may be placed in a little syrup for examination.

The action of syrup and glycerine will be more fully discussed in part V.

**139. Precautions to be observed in working.**—And now I must give a few words of advice to the young observer not to work too long at a time or with high powers, or to have the object illuminated more intensely than is necessary to enable him to see it clearly. To avoid strain, the habit of keeping both eyes open during observation should be acquired as soon as possible, and the observer should observe sometimes with one eye and sometimes with the other. Although the eye improves very much by practice, it may be seriously damaged by straining it injudiciously. At first the observer should work for half an hour only at a stretch, and if he finds that he is not fatigued and external objects are seen quite distinctly, as to form and colour, immediately the eye is removed from the microscope, the period of observation may be gradually increased until it reaches two or three hours a-day, but I think it unwise to work uninterruptedly for a longer time, and it is a good plan not to work regularly every day, at least for the first year or two. With care an eye which was at first weak may be inured to prolonged exertion and employed for the greater part of life without damage.

It is remarkable how little some persons suffer from microscopic or telescopic observation, but it is quite certain that many cannot work for long without great risk of seriously injuring their sight. No general rules, therefore, can be given which should apply to all. I have myself often worked with very high powers and with a very brightly illuminated field, straining the eye to the utmost in the hope of seeing more than was at first observable, and have kept this up for some hours at a time, so far, I am happy to say, without any

appreciable impairment of sight, but I would not recommend any one to subject himself to the same risk unless he passed through the same gradual process, using first only low powers, moderate light, and working only for a short time, slowly increasing the magnifying power, the illumination, and the period of study as he felt he was able to stand it.

**140. General Considerations with reference to the Nature of the Medium in which Tissues should be placed for Examination.**—If the structure be dry and very thin, or if it is required only to make out any general points with reference to its outline, or the character of its surface, it may be examined in air. So also many structures subjected to examination by low powers, and by reflected light, exhibit the general arrangement of their component parts very satisfactorily when mounted perfectly dry.

If, however, the texture be delicate and moist, and readily destroyed by careless manipulation, it is generally desirable to examine it in some aqueous fluid when quite fresh. The character of the fluid must differ in different cases. Water answers well in many instances, but the microscopical character of some textures are completely altered by water, or even altogether destroyed by it. Other tissues are so dark and opaque that they are not well displayed in water. Soft and cell-like structures become distended by it, but it does not follow that when this happens it depends upon a "cell," or bladder closed at all points, being distended. It does not prove that the cell has a membranous wall, for a mass of jelly may be made to swell out just like a "cell." If the jelly be made with a dense fluid, the more limpid water will pass in and mix with it. The "cell" thus becomes distended by this flowing in or osmosis, and often to such a degree that it is invisible. To prevent this result, it is necessary to immerse the structure in some fluid approaching to that in its substance, or in its interior, in density. A little white sugar may be dissolved in the water. Saliva, the vitreous humour, serum, or white of egg, from their viscosity do not permeate readily, and are advantageous media. But of all substances soluble in water, glycerine is one of the most useful to the microscopist. With glycerine he may obtain a fluid of any density, and of various degrees of refracting power. Moderately strong solutions of glycerine preserve animal and vegetable structures for any length of time. Glycerine is to moist tissues what Canada balsam is to textures which are capable of being dried, without their structure being impaired. The most dense, opaque, and ill-defined structures, immersed in glycerine become clear and transparent; and anatomical peculiarities which were before indistinct, or not observable, become demonstrable



without difficulty. Another advantage is, that by the addition of a little water all the original characters of the tissues are restored.

Further observations upon rendering tissues which are more or less opaque, transparent, will be found in part III.

**141. Of Examining and Preserving Specimens in the Dry Way.—**

Any specimen examined, or preserved permanently, as a dry object in air, must be protected from dust by being covered with thin glass, and the pressure of the latter upon the specimen must be prevented by the interposition of small pieces of cardboard at the edges of the thin glass, slightly thicker than the specimen itself. Objects may be mounted in the dry way in many of the cells described in §§ 114—131; but a simple cell made of wood or cardboard is sufficient for all practical purposes. The round vulcanised India-rubber rings cemented to the glass slides make capital cells for mounting such preparations.

The thin glass cover must be attached by a little very thick gum or by a paste made of gum and flour or chalk.

Among unorganised substances, there are many objects which may be mounted or preserved with advantage in air. Many crystalline bodies found native, and some crystals derived from the organic and inorganic kingdoms artificially prepared, may be examined or preserved permanently in air. Many of these present very beautiful appearances. Arsenious acid, common salt, benzoic acid, uric acid, crystals of the vegetable alkaloids, such as salicine and many crystalline salts, bone, teeth, hair, horn, the scales of butterflies and other insects, are examples of structures which may be examined in air and mounted dry. The general structure of many vegetable preparations may be shown in this simple manner. The petals of many flowers, different forms of vegetable cellular and vascular tissue, the epidermis, hairs, and other parts of plants, the seeds and seed vessels, spiral fibres, the stones of fruits, sections of wood, of the pith from the stem of various plants, pollen, the spores of ferns, mosses, and fungi, are examples of vegetable preparations which may be examined and preserved in air.

Thick objects preserved in the dry way are examined by reflected light only, but very thin dry tissues, like the epidermis from different parts of plants, may be examined by reflected or by transmitted light.

**142. Examination of Substances in Fluids.—**In choosing a fluid in which the specimen is to be immersed, its chemical composition, its transparency and its refractive power must be considered. The different preservative solutions described in pp. 53—59, may be used for the preservation of a variety of objects in fluid. If we wish for a fluid closely resembling water, but possessing the property of preserving the specimen, we may use the *solution of naphtha and creosote*, § 102, or

*naphtha and water*, or carbolic acid and water. If we require a fluid of higher specific gravity, some of the saline solutions, diluted with a proper quantity of water, may be used. If we wish for a solution which refracts highly, we may employ glycerine, or a mixture of glycerine and gelatine; while, if we require a fluid which has the property of hardening the structure, we may immerse it in a solution of *chromic acid*, *bichromate of potash*, *corrosive sublimate*, or *diluted alcohol*.

*In all cases the substance should be immersed for some time in the fluid, in which it is to be preserved, before being mounted permanently.* The cell made of *Brunswick black* or the thin glass cell, or other forms described in §§ 116—131, may be chosen according to the dimensions of the specimen. The object and fluid being placed in the cell, the thin glass cover is applied, with the precautions to which I shall presently advert. The superfluous fluid is removed with a piece of blotting paper, or a soft cloth, and after the edges have been allowed to dry a little, they are anointed with a thin layer of *Brunswick black*.

Almost every organised structure, and especially the soft moist tissues of the bodies of animals, may be advantageously preserved in fluid. It has been said that the solution employed in preserving a structure should resemble as nearly as possible in density and refractive power, the fluid which bathed it during life, but it is a fact that many even exceedingly delicate structures may be examined in fluids of high density, as syrup or glycerine, and peculiarities may be made out which are not to be demonstrated when they are examined in water or serum.

**143. Examination in Canada Balsam, Turpentine, and Oil.**—The well-known Canada balsam has long been a favourite medium for the preservation of microscopical specimens, on account of its penetrating and highly refracting powers. Turpentine possesses very similar properties, but from being a limpid fluid, it is far less useful than Canada balsam. All preparations to be mounted in Canada balsam must be thoroughly dried first. The desiccation must be effected by a temperature of not more than from 100 to 200 degrees. For the purpose of drying tissues, we may employ the water-bath alluded to in § 73, or we may place the specimen under a bell-jar close to a basin of strong sulphuric acid or chloride of calcium, which substances have the power of absorbing moisture in an eminent degree, pl. XX, fig. 131. Many textures in process of drying include a number of air bubbles in their interstices, and it is often very difficult to remove these. To effect this object, the preparation may be allowed to soak some time in turpentine, and the removal of the air is often much facilitated by the application of a gentle heat. If the

air cannot be removed in this manner, the preparation immersed in turpentine, may be placed under the receiver of an air pump. As the pressure is removed the air rises to the surface and the fluid rushes in to supply its place. A convenient and simple form of air pump is represented in pl. XX, fig. 129.

When the specimen has been thoroughly dried, and the air removed, it may be slightly moistened with turpentine before it is placed in the balsam.

In mounting a thin section of bone or other hard dry texture in Canada balsam, the following steps are taken: the glass slide having been warmed upon the brass plate, a small quantity of Canada balsam is removed upon the end of a piece of iron wire. By gently warming it, it becomes perfectly fluid, and may be allowed to drop in its proper place upon the glass slide. Or the metal pot containing the Canada balsam may itself be warmed, and a drop of the fluid balsam placed upon the slide. The preparation is now taken with a needle and placed in the drop of balsam, so that it may be thoroughly wetted by it in every part, or a solution of Canada balsam in chloroform may be dropped upon the specimen, § 95. A few air-bubbles may perhaps collect upon the surface of the balsam, and by moving the slide from side to side, with a slight rotatory movement while the balsam is quite fluid, the bubbles may be seen to collect in one spot upon the surface. They may be made to burst by the application of a warm needle, or completely removed by touching them with a cold wire to which the balsam including them will adhere. All bubbles having been removed, the thin glass, which has been perfectly cleaned and slightly warmed on the brass plate, is taken in a pair of forceps,—and gently allowing one side of it to come in contact with the balsam,—is permitted to fall very slowly upon the specimen, in such a manner that the balsam gradually wets the thin glass, without including air-bubbles. It is then pressed down slightly with a needle, and the slide placed in a warm place. The superabundant balsam may be scraped away, and the preparation when cold, cleaned with a little turpentine, and a soft cloth, or piece of wash-leather.

The feet and hard parts of the fly and other insects, and the ova of small insects may be mounted in Canada balsam. The shells and hard parts of the covering of many of the lower animals, the palates of various mollusks, such as the limpet, and many fresh-water species, the coriaceous coverings of insects, their antennæ, stings, eyes, feet, wings, and scales of their wings, the tracheæ penetrating every part of their organism with their spiracles or external openings, and in some cases the entire insects themselves, the scales

of fishes, sections of bone, teeth, horn, hoofs, claws, nails, specimens of various kinds of hair, are examples of objects derived from the animal kingdom which may be examined in this manner and mounted permanently if desired.

If the observer desires merely to ascertain how a structure looks when examined in a highly refractive medium like balsam, he may use turpentine, which can afterwards be dissipated by evaporation.

Oil is an advantageous highly refracting medium for examining certain structures in. The entozoa which may often be obtained from the oily sebaceous matter squeezed from the follicles of the skin of the nose or scalp, should be immersed in oil. They can generally be found in the wax from the ear.

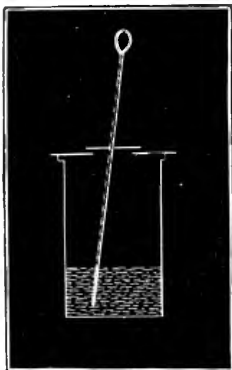
Some tissues may be made to present different appearances although mounted in the same medium. Thus bone exhibits very different characters when immersed in Canada balsam, according to the manner in which it is mounted. In every part of one specimen, small black spots of irregular shape may be seen. From these a number of minute dark lines radiate, and inosculate pretty freely with corresponding lines from other spots. In another preparation the entire section may appear perfectly clear, and its structure nearly uniform everywhere. The first appearance is produced when a section is mounted in old viscid balsam; the second when it is immersed in fluid balsam, after having been previously wetted with turpentine.

The cause of these differences is interesting and worthy of attentive study. The little black spots (*lacunæ*) and dark lines (*canaliculi*) were formerly considered to be small solid bodies, and the spots were improperly termed *bone corpuscles*. They consist in truth of little cavities or spaces in the bony tissue, and contain air. In the second specimen the highly refracting oil of turpentine passed up the canaliculi and into the *lacunæ* driving out the air, thus rendering the tubes and spaces invisible. The *lacunæ* contained in the fresh bone, masses of germinal matter (*nuclei*), but when the bone had become dry, the moist material dried up, and air rushed into the *lacunæ* and *canaliculi* to supply its place. The great difference between the refracting power of the air contained in these little cavities, and the surrounding osseous tissue gives rise to their dark appearance. The above remarks upon the structure of bone apply only to the dead and dried tissue.

#### OF PREPARING TISSUES FOR MICROSCOPICAL EXAMINATION—OF DISSECTING AND CUTTING THIN SECTIONS OF TISSUES.

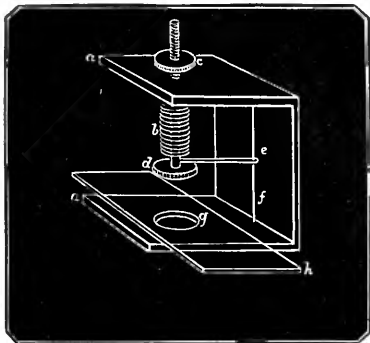
**144. Of Making Minute Dissections.**—Minute dissections are usually carried on under the surface of fluid with the aid of small scissars,

Fig. 127.



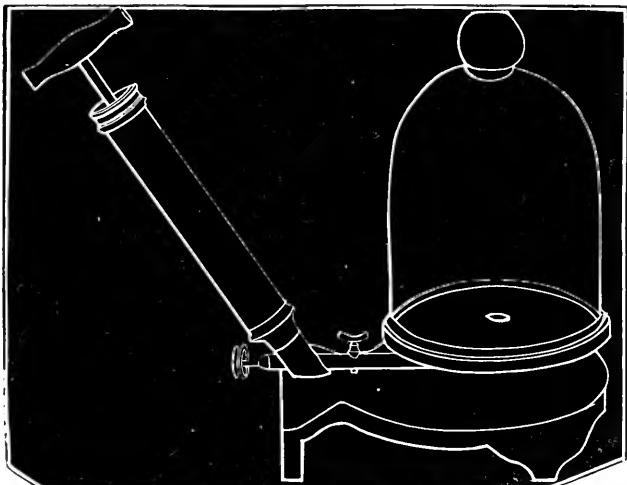
Vial, for containing Canada balsam. p. 60.

Fig. 128.



Instrument for applying graduated pressure to objects under thin glass. p. 61.

Fig. 129.

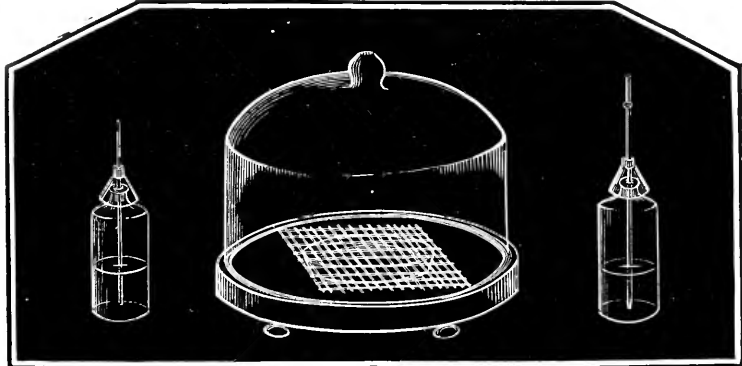


Air-pump, for removing air from microscopical specimens. p. 77.

Fig. 130.

Fig. 131.

Fig. 132.



Test bottle, with stirring rod and cap to prevent entrance of dust.

Glass shade, with sulphuric acid and waxen cone support for drying objects. p. 76.

Pipette inserted through cork or stopper of test bottle.



needles, or small knives, and forceps. If the preparation has been preserved in spirit or other solution, it must be dissected in the same fluid, but in ordinary cases clear water may be used. The microscopist should be provided with a few small dishes, varying in size, and about an inch or more in depth. The large built cells, pl. XVIII, figs. 109, 110, make very good troughs for dissecting in, but small circular vessels are made on purpose.

**145. Loaded Corks.**—The object to be dissected is attached to a loaded cork by small pins, pl. XXI, fig. 134. We may take a piece of flat cork rather smaller than the cell, and then cut a piece of sheet lead somewhat larger than the cork. The edges of the lead are then folded over the cork and beaten down slightly with a hammer, and may afterwards be filed with a rough file.

The object being fixed upon the cork and placed in the cell, fluid is poured in until it just covers the surface, pl. XXI, fig. 133. A strong light is then condensed upon it by means of a large bull's-eye condenser, or by a large globe full of water. I have always found that delicate dissections could be made with the greatest facility without the aid of a dissecting microscope, provided a strong light was condensed upon the object. Occasional examination of the dissection with a lens of low power is advantageous; but if a lens be employed during the dissection there is great danger of accidentally injuring the specimen, as it is impossible to judge of the distance which the needle point may be beneath the surface of the fluid. Minute branches of nerves or vessels may in this way be followed out, and small pieces of the different tissues into which they can be traced may be removed for microscopical examination with a pair of fine scissors, pl. XV, fig. 82. Membranes may be dissected from the structures upon which they lie in a similar manner. By this plan the nervous system of the smallest insects can be readily dissected. The mode of proceeding is represented in fig. 133.

**146. Tablets upon which Dissections may be Pinned out.**—Many preparations require to be arranged in a particular position previous to being mounted as permanent objects. *Slabs of wax* are usually employed by anatomists for this purpose, but when transparency is required the dissections may be attached by threads to thin plates of *mica*.

I have found that the best slabs may be made of a mixture of *wax* and *gutta percha*, in the proportion of one part of the former to two of the latter. The ingredients are to be melted in an iron pot, over a clear fire, and well stirred. When quite fluid, the mass may be poured upon a flat slab and allowed to cool. Thin cakes of about the eighth of an inch in thickness are thus obtained, and they

can easily be cut with a knife to fit the cells intended for the preparation. Pins or small pieces of silver wire may be inserted into these slabs, and will adhere firmly although the slabs are very thin.

*Cutting thin Sections of Soft Tissues.*

**147. Of obtaining Thin Sections of different Textures for Microscopical Examination.**—The instruments required for obtaining thin sections of soft tissues have been described in pp. 45, 46. See also pls. XIV and XV.

It is scarcely necessary to observe that such different textures as muscular fibre and gland structures, and other soft tissues, require a process for cutting them different to that which is applicable for cutting thin slices of such tissues as hair, horn, bone, or teeth.

Where thin sections of no very great extent of tissue are required they may be obtained by scissors, p. 46, by the ordinary scalpel, p. 45, by the double-edged knife, or by Valentin's knife. Whenever a thin section of a thin tissue is made, the instrument employed must be thoroughly wetted with water, and the section, after its removal, should be carefully washed, by agitating it in water, or by directing a stream of water upon it from the wash-bottle, p. 86, fig. 143, pl. XXII. This washing is absolutely necessary to remove from the surface of the section particles of debris, which would render the appearances indistinct, and interfere with the clearness of the specimen when it was subjected to examination in the microscope. The section may then be transferred to the fluid in which it is to be examined or preserved. If the specimen be immersed in glycerine, alcohol, or other fluid, the knife must be wetted and the specimen washed with the same.

**148. Cutting Sections and handling Bodies under the Microscope.**

—With practice the observer may carry on a dissection under the microscope. It is not difficult to work under an inch, and under a half inch it is possible to dissect with the aid of a fine knife or very sharp needles. The erector, p. 4, must be employed, or the observer must learn to work although everything appears reversed. Various instruments have been proposed to aid the observer in dissecting or removing specimens which are highly magnified.

*On an instrument for making sections on the stage of the microscope.*

—V. Hensen, who has made some beautiful observations on the organ of hearing of crustacea, has designed an ingenious instrument for making thin sections of tissues while in the field of the microscope. (In Schultze's Archiv, April, 1866, vol. II, p. 46.)

Under a power of fifty diameters an extremely thin section of textures of a certain hardness may be made with facility. This instru-



ment, which I have not yet seen, is made by Beckmann, of Kiel, and costs seven thalers, or about a guinea.

*Mechanical finger.*—Professor Smith has made an instrument which he terms a mechanical finger, of some value for some kinds of microscopical work (Silliman's Journal, No. 123). By an arrangement of springs and levers a small bristle can be caused to move or take up any minute object while it is being examined under the object-glass. An object may be selected, raised from the slide, and held while a clean slide is placed in position to receive it. This instrument has been made by Mr. Baker, of Holborn. Dr. Maddox has suggested a slight modification, which simplifies the instrument somewhat. Although the mechanical finger may be of value in special investigations, the general observer will not require it, and the thorough student will probably acquire such dexterity in handling specimens while they are in the field of the microscope that he will not feel the want of any mechanical apparatus.

**149. Dissecting Tissues under the Microscope with the aid of the Compressorium.**—In many cases the observer may desire to dissect an extremely delicate structure *under the microscope*, for in this way much information can often be acquired with reference to the exact relation existing between the structural elements of the tissue. This object may be gained by means of a little instrument termed a *compressorium*, which consists simply of a convenient arrangement by which pressure can be applied to an object while under examination, pl. XXI, figs. 135, 136. This pressure being applied gradually, the texture becomes frayed out as it were, and particular structures can often be teased out from a tissue, and demonstrated more distinctly than by any other method.

The structure of the compressorium is very simple. Many different forms have been recommended, one of the simplest consisting of a thick brass plate with a hole in the centre to admit the light. On one side of this is the fulcrum of a lever, the short end of which acts upon a circular ring carrying the thin glass to cover the preparation, while to the longer arm is attached a screw, which by being turned causes the thin glass to be pressed tightly upon the object placed upon a piece of plate glass placed over the hole in the plate of the compressorium. A more perfect form of instrument has been arranged by Mr. Highley. It is represented in pl. XXI, fig. 136.

The plate glass is usually fixed in the hole in the brass plate, but it is more convenient to have a ledge attached to one side, so that an ordinary plate-glass slide may rest upon it. With such an arrangement, the tissue to be examined can be placed as may be thought

desirable, upon any part of the glass before it is removed to the compressorium. A very convenient form is employed by M. Quatrefages, in which it is possible to examine the object upon either side.

The compressorium has been arranged by Mr. Ross so that the object may be placed between two pieces of thin glass, and either side of it subjected to examination under very high powers. Mr. Beck, I think, improved upon the plan adopted by Mr. Ross.

**150. Cutting Sections of Tissues which have been previously dried.**—There are, however, many tissues of which sections cannot be obtained in this simple manner. It is almost impossible to cut sections of soft membranous textures perpendicular to the surface, sufficiently thin for examination. In such cases, we may pin out the texture upon a board when perfectly fresh, and expose it to the atmosphere, or over sulphuric acid under a bell jar, pl. XX, fig. 129, until it is quite dry. Thin sections may then be cut very easily, and upon being moistened with water they will resume their recent appearance. The very delicate nervous tissue of the retina may be cut into very thin sections by drying the eye after it has been cut open, and pinned out flat on a board. The vitreous humour is not to be entirely removed, as it protects the retina and dries up with it. Very thin sections of the skin of various animals, certain vegetable tissues, and of many other textures may be obtained by this process.

**151. Hardening the Tissue.**—Some textures require different treatment in order to render them sufficiently hard to enable us to cut thin sections. Boiling in water is sometimes useful for this purpose. Some tissues may be hardened by being soaked in alcohol, or chromic acid, or in syrup, while not a few require special modes of treatment, which are applicable to them alone. *See* part III, where the use of various solutions for hardening is described.

*Cutting thin Sections of Hard Tissues.*

**152. Of Making Thin Sections of Dry Bone.**—For obtaining thin sections of bone, a totally different process is requisite. In the first place, a section as thin as possible is removed from the bone with the aid of a thin sharp saw, pl. XXI, fig. 138. This may be made somewhat thinner by a file, and afterwards ground down to the required degree of tenuity upon a hone. The best stones for this purpose are the Arkansas oil stones or the Turkey stones which have been ground perfectly flat. The section may be kept in contact with the stone by the pressure of the thumb or finger, or with a piece of



Fig. 141. Instrument for mixing minute doses of salts under water. p. 74

Fig. 142.

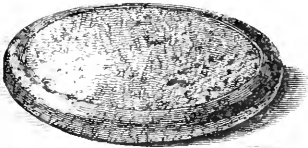


Fig. 142. Dish for holding or drying small amounts of material. p. 74

Fig. 143.

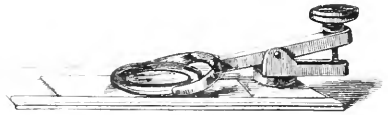


Fig. 143. Compressorium for pressing or flattening up tissues. p. 74

Fig. 144.

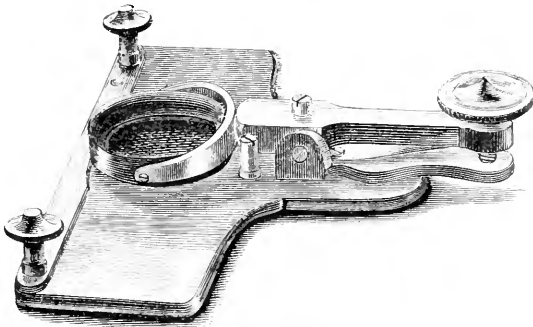


Fig. 144. Compressorium (of Müller). p. 81

Fig. 145.

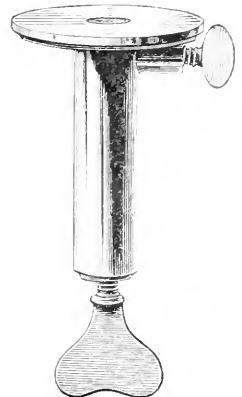


Fig. 145. Instrument for holding thin sections of wood. p. 81

Fig. 146.



Fig. 146. Instrument for holding thin sections of wood. p. 81



cork, or lastly, it may be rubbed between two hones, a proceeding which saves much time.

It is to be ground down with the aid of a little water, and when sufficiently thin it may be subjected to examination in the microscope. It will, however, be found, that the beauty of the tissue is completely obscured, owing to the number of scratches upon its surface. These may be removed by rubbing the section first upon a very smooth dry hone, and afterwards upon a piece of plate glass. After the piece of bone has been properly polished, no lines will be seen upon it, when it is examined in the microscope.

**153. Teeth.**—Sections of dry teeth cannot be advantageously prepared in the manner just described, owing to the very brittle nature of the enamel. The better way is to grind the tooth down at a dentist's lathe until a section sufficiently thin be obtained.

Sections of *fresh* bone and teeth may be prepared moist so as to show many more important points in their structure and mode of growth, according to the plan described in part V. After they have been soaked for some time in glycerine and acetic acid, very thin shavings even of enamel may be obtained with a strong sharp knife. The calcareous matter may be dissolved out from specimens by dilute hydrochloric acid, and sections of the decalcified matrix easily cut with a sharp knife.

**154. Sections of Shells** of many of the lower animals, and the hard shells and stones of fruit may be made in a similar manner, but very hard textures such as fossil wood must be obtained of the lapidary. See also "Of examining minerals and fossils," further on.

**155. Horn and Hair.**—Thin sections of horn and textures of this description may be cut without difficulty with a sharp strong knife, pl. XV, fig. 81.

*Hair.*—There are many ways of obtaining thin transverse sections of hair. Thus a number of hairs may be united together with a little gum, so as to form, when dry, a firm hard mass. Thin sections of this can readily be made, with a sharp knife, and the individual pieces may be separated from each other, by the application of a drop of water. These may be mounted in fluid, or dried and preserved in Canada balsam, § 143.

Or the hairs may be placed between two pieces of cardboard, or between two flat pieces of cork, and when tightly pressed in a vice, thin sections of the hair, including the cardboard and cork, can be obtained with a sharp knife. For cutting thin transverse sections of hair, my friend, Professor Weber, of Leipzig, recommends a very simple expedient. He suggests that the beard should be shorn very closely, and then after a few hours shorn again. In

this way excessively thin sections of hair in great numbers may be obtained, and can be easily removed from the lather, well washed in distilled water and dried at the ordinary temperature.

**156. On cutting Sections of Wood and Textures of that Character.**—Thin sections of various woods and other vegetable textures of a certain degree of firmness may be cut with the aid of the instrument represented in pl. XXI, fig. 137. A piece of wood, after having been allowed to soak for some time in water, is placed in the hole, and kept in its position by the side screw. Upon turning the lower screw the wood is forced above the brass plate. A clean section is now made with a sharp strong knife or razor. By turning the screw beneath, very slightly, the wood is forced above the surface of the brass plate, and thus a section of any required thickness may be obtained.

#### ON THE SEPARATION OF DEPOSITS FROM FLUIDS.

Before we can ascertain the nature of a deposit suspended in a fluid, it is necessary to separate it as much as possible, and collect it into a small space. Diffused as the deposit often is through a large bulk of fluid, the observer would scarcely be surprised if he failed to distinguish it, when a drop was placed under the microscope.

The ordinary method of separating deposits from fluids is by filtration. The arrangement of the funnel and the mode of folding the paper, for filtering, are shown in pl. XXII, figs. 139 and 147. Filtration, however, will not answer for microscopical purposes, when a mere trace of deposit has to be collected from a large quantity of fluid. Moreover, particles from the filtering paper often become mixed with the deposit and lead to confusion. Hence other modes of proceeding must be resorted to.

**157. Conical Glasses.**—In order to collect the deposit for microscopical examination, the fluid containing it is placed in a conical glass, the lower portion of which is narrow, not, however, terminating in a point but in a slightly rounded extremity. After standing for some hours, the deposit falls to the narrow portion of the glass, and may be removed with the pipette. A useful form of conical glass is represented in pl. XXII, fig. 141.

**158. The Pipette** consists of a glass tube, about ten inches in length, the upper extremity being slightly enlarged, so that the finger may be conveniently applied to it, and the lower orifice contracted, so as to be about one tenth of an inch in diameter. It is convenient

to have a ridge around the glass tube, about three inches from its upper extremity, pl. XXII, fig. 140.

**159. Removing the Deposit with the Pipette.**—The removal of the deposit is easily effected. The pipette is held by the middle finger and thumb, while the index finger is firmly applied to its upper extremity. The point is next plunged beneath the surface of the fluid and carried down to the deposit, a portion of which will rush up the tube if the pressure of the finger upon the upper extremity be slightly diminished. The deposit having entered the tube, the pressure is re-applied, and the deposit contained in the pipette can be removed from the fluid, fig. 141.

**160. On Separating the Coarse from the Finer Particles of a Deposit.**—Many deposits, by being diffused through a large quantity of water, may be divided into several portions. The fluid, with substances suspended in it, is well stirred, and, after being allowed to stand for a very short time, all but the deposit is poured off into another vessel. In this the fluid is again allowed to stand for a short time, and again poured off. This process may be repeated several times. In the first glass, only the coarser particles will be found; in the second, slightly finer particles; in the third, still finer ones, and so on; a longer period being allowed for the subsidence in each successive case.

The coarse particles may also often be separated from finer ones by straining the deposit through muslin. Various preservative solutions, which I have already described, are applicable for preserving deposits from fluids. Many, again, may be mounted in Canada balsam.

**161. Separation of Deposit when very small in Quantity.**—Where the deposit is exceedingly small in quantity, and diffused through a great bulk of fluid, a slight modification of the above plan must be resorted to. The pipette, containing as much of the deposit as can be obtained, is removed from the glass vessel containing the fluid. Its contents are prevented from escaping by the application of the finger to its lower orifice. The upper extremity is then occluded with a small cork. Upon now removing the finger from the lower orifice, of course no fluid will escape. The pipette is allowed to stand with its mouth downwards upon the glass slide, in which position it may be permitted to remain some hours, either being suspended with a string or allowed to lean against some upright object. It is obvious that under these circumstances the most minute deposit contained in the fluid will gravitate to its lower part, and be received upon the slide, without the escape of much of the fluid, fig. 145, pl. XXII. Or the sediment, having been allowed to

subside in a conical glass, may be poured into a very narrow test tube. Upon a glass slide being applied to the open end, the tube may be inverted, and the deposit will gradually collect upon the slide. The arrangement will be understood by reference to fig. 146.

According to either of the above methods any insoluble substances diffused through fluids can be easily collected for the purposes of examination. In collecting shells of the diatomaceæ for microscopical examination they are often diffused through a considerable quantity of water, allowed to subside, and obtained in the manner above described.

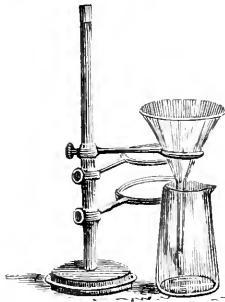
**162. Examination of the Deposit.**—The deposit removed by the pipette may be transferred to the thin glass, tinfoil, or Brunswick black cell, §§ 115 to 118, and submitted to examination in the microscope. The animalcule cage, p. 66, will also be found very convenient for the examination of deposits from fluids, and it serves the purpose of a compressorium when a very great amount of pressure is not required. It is important that the shoulder of the animalcule cage upon which the cover fits should be at least as wide as the one figured in pl. XVIII, fig. 112, otherwise when the glasses are not cleaned immediately after use, solutions which have been examined are apt to dry and thus the removal of the cover without fracture of the glass is very difficult.

**163. Wash-bottle.**—In many operations, especially in washing deposits previous to microscopical examination and in filtration, the wash-bottle used by chemists is of great use, as by it a stream of water of any required degree of force can be easily directed to any particular point, either for the purpose of washing away foreign particles, or for removing part of the deposit itself. The wash-bottle is also of great use in preparing sections of soft tissues for observation. It is made by inserting a cork into an ordinary half-pint bottle. Through the cork pass two tubes, bent at the proper angle. The longest terminates in a capillary orifice, while its other extremity reaches down to the bottom of the bottle. The shorter tube reaches only to the lower part of the cork, pl. XXII, fig. 143. By blowing through the shorter tube, air is made to press upon the surface of the water, which is thus driven up the longer tube and out at its capillary orifice.

The observer must have a stock of *small tubes*, about two inches in length and a quarter of an inch in diameter, such as homeopathic globules are kept in, fig. 144, pl. XXII, and several small *watch glasses*, of different sizes.



Fig. 139.



Small iron stand with funnel and beaker arranged for filtering. p. 34.

Fig. 140.



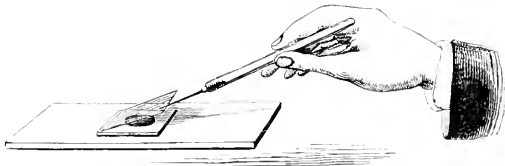
Pipettes made of glass tubing. p. 34.

Fig. 141.



To illustrate the mode of using the pipette. p. 34.

Fig. 142.



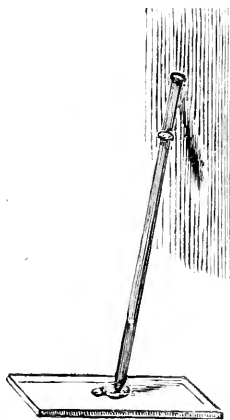
To illustrate the manner in which the thin glass is allowed to fall gradually upon an object mounted in fluid. p. 35.

Fig. 143.



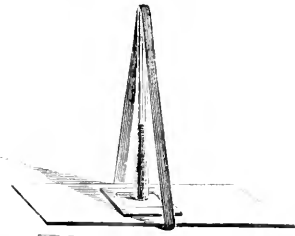
Wash bottle. p. 34.

Fig. 145.



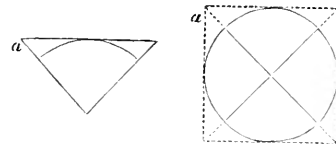
Mode of collecting deposit upon a glass slide from fluid contained in a pipette. p. 35.

Fig. 146.



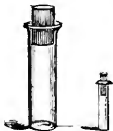
Shows the manner in which a very small quantity of deposit may be collected from a fluid by placing it in a test tube and inserting it over the glass slide. It is kept in position by an india-rubber band. p. 35.

Fig. 147.



Mode of folding filter paper. p. 34.

Fig. 144.



Corked tubes for containing prepared tissues. p. 34.



## ON MAKING INJECTIONS.

The arrangement of the minute vessels or capillaries distributed to the various textures of man and animals is not to be demonstrated in all instances by the usual methods of investigation, in consequence of the transparency of the walls of the tube. Indeed, in an ordinary examination of a tissue in the microscope, one often fails to detect the least trace of any structure, although it may be almost entirely composed of distinct tubes and vessels. Some even yet maintain the opinion, that the capillaries are to be looked upon in the light of mere channels in the interstices of the tissues, rather than as tubes, with their own proper walls. If, however, this view were correct we should not meet with the perfectly circular outline which the section of an injected capillary vessel frequently presents; nor should we be able to obtain capillaries completely isolated from other tissues.

**164. Of Natural and Artificial Injections.**—Sometimes the capillary vessels remain turgid with blood after the death of the animal, and a *natural injection* results. Natural injections, however, are accidental and cannot be obtained in the case of every texture. In order, therefore, to investigate the arrangement of the vessels, it is necessary to resort to the process of *artificial injection*, by which a certain quantity of coloured material is forced into a vessel of convenient size. After passing along a large arterial trunk, the injection penetrates into the smallest vessels and sometimes even returns by the veins. The colouring matter employed may be *opaque* or *transparent*. In the first case the injected preparation can only be examined by *reflected light* as an *opaque object*, p. 18, while transparent injections may be subjected to examination by *transmitted light*, p. 18, as well as by *reflected light*. Examples of opaque and transparent injections in which different substances have been employed as colouring matters, can be purchased at all the microscope makers. *See* list at the end of the volume. Every student is, however, strongly recommended to learn to make injected preparations for himself.

**165. Instruments required for making Injections.**—The different instruments required for making artificial injections are the following:—

An *injecting syringe*, of about the capacity of one ounce or even half an ounce, pl. XXIII, fig. 151. The piston of the injecting syringe should be covered with two pieces of leather, which may be very easily removed and replaced, fig. 148. The first piece, *a*, is applied and screwed down with a brass button, *b*. The piston is

then passed down the tube and forced out at the lower opening. The second piece of leather, *c*, is then put on, and fixed in its place with another button, *c*. In the syringes now made for me by Mr. Matthews, the piston consists entirely of metal. I have found syringes of this description work exceedingly well, and the necessity for re-leathering is obviated, but they are rather expensive.

*Pipes*, of different sizes, to insert into the vessels, fig. 156. The tubes of the smaller pipes should be made of silver.

*Corks*, of the form represented in fig. 150, for the purpose of plugging the pipes while the syringe is being filled with injecting fluid. A stopcock, fig. 155, is also useful for the same purpose.

*Forceps*, of the form shown in fig. 149, which are known to surgical instrument makers as *bull's nose forceps*, for stopping up any vessels through which the injection may escape accidentally.

*A Needle*, of the form of the *aneurism needle* used by surgeons, for passing the thread round the vessel to tie it to the pipe which is inserted into it, fig. 158. This needle may be made of an ordinary darning needle which has been carefully bent round after having been heated in the flame of a lamp. The *thread* which is used should be strong but not too thin, as there would be danger of its cutting through the coats of the vessel.

**166. Injection Cans.**--Size or gelatine is used as the material in which the opaque colouring matter is suspended. It must be melted in a water-bath and strained immediately before use. The copper injecting can forms a very convenient apparatus for melting the gelatine. There are five cans in the bath, represented in fig. 152, pl. XXIII, so that injection may be very conveniently transferred from one into the other, while all may be kept warm over an ordinary lamp.

The operation of injecting is described in page 98.

#### *Of Opaque Injections.*

Although by the old system of making opaque injections there is no chance of making out new points in the structure of tissues and organs, I shall give directions for making these injections, in case some of my readers may desire to prepare specimens. The observer must not, however, suppose that he will add much to existing knowledge, however great an adept he may be at this difficult process. To make a perfect vermilion injection undoubtedly requires a degree of skill which any one may be proud to possess, but for all that it is certain that little which has not been long since demonstrated will be discovered by the process.

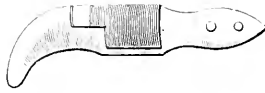
**167. The Size** should be of such a strength as to form a tolerably

Fig. 148.



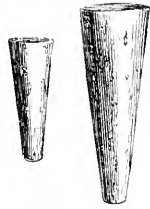
Shows the manner in which the piston of the nozzle and syringe is made actually a c. pieces of leather. p. 87.

Fig. 149.



Full's nose forceps for closing an open vessel to prevent the escape of the injected fluid. p. 85.

Fig. 150.



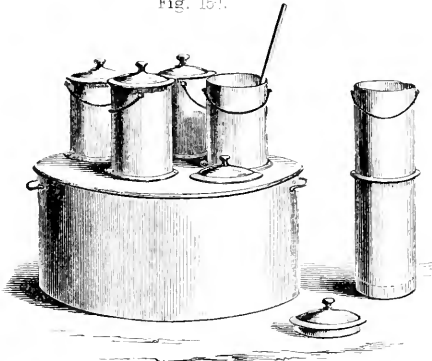
Stops for stopping the pipes while the injecting syringe is being reloaded. p. 85.

Fig. 151.

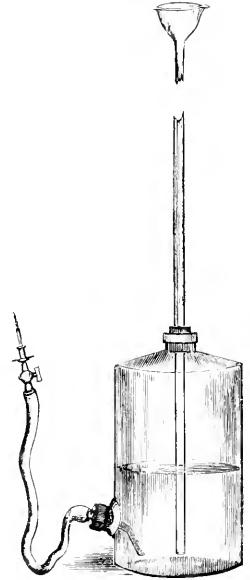


Life line for getting small animals or portions of tissue. p. 87.

Fig. 152.

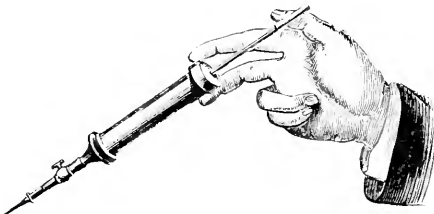


Heating stove. It may also be used as a water bath for drying objects or for conducting evaporation. p. 88.



Apparatus for performing the operation of injecting by the pressure of the injecting fluid. p. 100.

Fig. 154.



Performing the operation of injecting. p. 85.

Fig. 155.



Stopcock and injecting pipe which fit on to the syringe. p. 85.

Fig. 156.



Fig. 157.



Injecting pipe with ornate near point. p. 103.

Fig. 158.



Needle for passing in lead or a vessel the end of which is to be used in an injected pipe. p. 85.



firm jelly on cooling. If gelatine is employed it must be soaked for some hours in cold water before it is warmed. About an ounce of gelatine to a pint of water will be sufficiently strong, but in very hot weather it is necessary to add a little more gelatine. It must be soaked in part of the cold water until it swells up and becomes soft, when the rest of the water, made hot, is to be added. Good gelatine for injecting purposes may be obtained for two shillings a pound.

**168. Colouring Matters.**—The colouring matters usually employed in making opaque injections are the following :—*Vermilion*, *Chromate of Lead*, and *White Lead*. Of these, vermilion affords the most beautiful preparations, but chromate of lead properly prepared is much cheaper, and it may be obtained in a state of more minute division. White lead forms a good colouring matter, but its density, and its tendency to become brown and black when exposed to the action of sulphuretted hydrogen, formed in the decomposition of the tissues, are objections to its use.

**169. Vermilion** of sufficiently good quality can be purchased of all artists' colourmen for six or eight shillings a-pound. If upon microscopical examination a number of very coarse particles be found in the vermilion, it will be necessary to separate these by washing in water in the manner described in § 160.

**170. The Chromate of Lead** is prepared by mixing cold saturated solutions of acetate of lead and bichromate of potash. The yellow precipitate is allowed to settle, and after pouring off the clear solution of acetate of potash resulting from the decomposition, it is shaken up with water, again permitted to settle and mixed with strong size or gelatine. After being strained through muslin the mixture may be injected into the vessels.

**171. The Carbonate of Lead or White Lead** is prepared by mixing saturated solutions of acetate of lead and carbonate of soda. The precipitate is to be treated as the former one and mixed with size.

In preparing opaque injections, the observer should bear in mind that the colouring matter should be well mixed with the size, otherwise the vessels will not be uniformly filled, and it is better to employ a small syringe rather than a large one, as there is not so much chance of the colouring matter separating from the size before the mixture is forced into the vessels. In all cases the mixture may be made in a mortar, poured into one of the injection cans, fig. 151 *a*, and strained into another through muslin just before it is injected into the vessels of the animal.

**172. Size of the Particles of the Colouring Matter used.**—The size of the particles of the different substances employed in making opaque injections is represented in pl. XXIV, and if the different figures be compared with one another, it will be observed that those colouring matters which have been recently prepared are in a much more minute state of division than those which have been kept for some time. The appearances represented were obtained by examination with a power of 215 diameters.

Opaque injections are represented in pl. XXV, figs. 161, 162.

**173. Of Injecting Different Systems of Vessels with Different Opaque Injections.**—It is often desirable to inject different systems of vessels distributed to an organ with different colours, in order to ascertain the arrangement of each set of vessels and their exact relation to one another. A portion of the gall-bladder in which the veins have been injected with white lead, and the arteries with vermilion, forms a beautiful preparation. Each artery, even to its smallest ramifications, is seen to be accompanied by two small veins, one lying on either side of it. A beautiful injection of the gall-bladder is represented in pl. XXV, fig. 161.

In an injection of the liver, four sets of tubes may be injected with the following different colouring matters:—The artery with *Vermilion*, the portal vein with *White Lead*, the duct with *Prussian Blue*, and the hepatic vein with *Lake*. Many opaque colouring matters besides those above-mentioned may be employed for double injections.

#### *Of Transparent Injections.*

**174. Advantages of Transparent Injections.**—For many years I have abandoned the old plan of making injected preparations, in favour of such transparent injecting fluids as are miscible with water in all proportions. Besides the colouring matter these contain solutions which exert a preservative action upon the tissue with which they come in contact, or render certain elements of the tissue more transparent or opaque. By this new plan of injection most important advantages are gained, for not only are the vessels injected with colouring matter, but —

1. The tissues are preserved from decomposition or change by the action of the fluids of the body which are washed out by the injection.

2. Certain tissues may be rendered more distinct.

3. Every structural element of the tissue can be seen as well as the vessels.





Scale *Thousandths of an Inch*

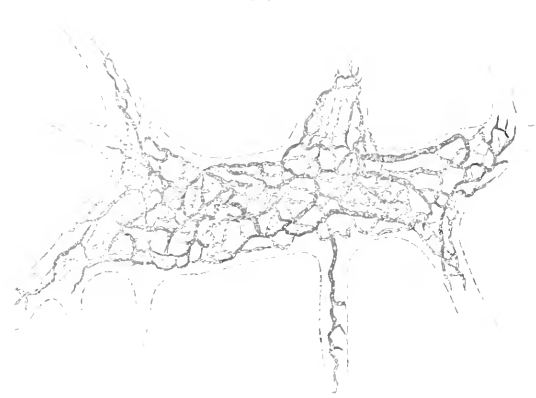


Fig. 1



4. Tissues prepared by this process can be subjected to examination, by powers magnifying more than 5,000 diameters. See part V.

5. All tissues may be mounted in aqueous preservative solutions, and the most delicate structures are retained in their integrity.

6. By this process of injection alone can the alteration of the most delicate tissues, which occurs very soon after death, be prevented.

It will be seen that several important principles are involved in this new process, which will be more fully enunciated in part V.

Of late years carmine fluid has been much used for transparent injections, especially in Germany; but although many of these specimens are very beautiful, I am not aware that new facts have been revealed by the process. As the specimens *are mounted in balsam*, the structure of the tissues external to the vessels is completely lost. Moreover, the vessels with the contained injection have become much reduced in diameter by the process of drying, and generally the appearances seen cannot be regarded as natural.

All that is to be learnt by such modes of preparation, has been already learnt. For more minute investigation it is absolutely necessary that the tissue be prevented from undergoing post-mortem change, and that it be preserved in some *viscid aqueous fluid*. By drying the tissue its structure is often destroyed. The only mode of preparation by which injected textures can be subjected to examination by the highest powers, and which permits of all the several structures entering into their composition being displayed in the same specimen, is that which I am advocating in conjunction with the staining process described in part V.

In order to inject the vessels for examination by transmitted light several different substances may, however, be used as injecting fluids; but if it is desired to study the tissues as well as the arrangement of the vessels, the points just adverted to must be borne in mind.

**175. Injection with Plain Size.**—A tissue which has been injected with plain size, when cold is of a good consistence for obtaining thin sections, and many important points may be learnt from a specimen prepared in this manner which would not be detected by other modes of preparation. A mixture of equal parts of gelatine and glycerine is, however, much to be preferred for this purpose, and the specimen thus prepared is sure to keep well. Very thin sections of spongy tissues like the lung may be most successfully made after injection with strong gelatine or gelatine and glycerine.

**176. Colouring Matters for Transparent Injections.**—The chief colouring matters used for making transparent injections are *carmine* and *Prussian blue*. The former may be prepared by adding a little

solution of ammonia (liquor ammoniac) to the carmine, and diluting the mixture until the proper colour is obtained, or it may be diluted with size. The latter by adding a persalt of iron to a solution of ferrocyanide of potassium.

**177. Advantages of Employing Prussian Blue.**—In order to inject satisfactorily the most minute vessels of a tissue, and at the same time to demonstrate their relation to adjacent structures, we must be provided with an injecting medium which possesses the following properties:—The fluid should be of such a consistence that it will run readily through the smallest vessel. It must contain a certain amount of colouring matter to render the arrangement of the vessels distinct, but must be sufficiently transparent to admit of the examination of the specimen by transmitted light. The colouring matter must not be *soluble*, for in this case it would permeate the tissues indiscriminately, and would thus prevent the vessels from being distinguished from other textures. Though insoluble, the particles of which the colouring matter is composed should be so minute as not to exhibit distinct granules when examined with the highest powers, for if this were so, the specimen would have a confused appearance. The fluid in which the colouring matter is suspended, must be capable of permeating the walls of the vessels with tolerable facility. It must possess a certain refractive power, and a density approaching to that of the fluid which surrounds the tissues in the natural condition. It must be of such composition that it may be employed without the application of heat.

The injecting fluid must not escape too readily from the numerous open vessels necessarily exposed in cutting a thin section of the tissue for examination, and particles accidentally escaping ought not to adhere intimately to the surface of the section, for this would render the specimen confused and indistinct, when subjected to examination, especially if high magnifying powers are required. The fluid employed must not interfere with the preservation of the specimen. The injecting fluid ought not to undergo any alteration by being kept for some time, and it should be cheap and capable of being readily prepared.

*The Prussian blue fluid* which consists of an insoluble precipitate, so minutely divided, that it appears like a solution to the eye, fulfils all these requisitions. The particles of freshly prepared Prussian blue are very much smaller than those of any of the colouring matters employed for making opaque injections. For many years I have employed Prussian blue as the injecting fluid, and according to my experience it possesses advantages over every other colouring matter. It is inexpensive. It may be injected cold. The preparation does not require to be warmed. No size is necessary.

The injection penetrates the capillaries without the necessity of applying much force. It does not run out when a section is made for examination, neither do any particles which may escape from the larger vessels divided in making the section, adhere to it and thus render the section obscure. A structure may be well injected with it in the course of a few minutes.

Specimens prepared in this manner may be preserved in any of the ordinary preservative solutions, or may be dried and mounted in Canada balsam (but I give the preference to glycerine, § 100, or glycerine jelly, § 106), and they may be examined with the highest magnifying powers. After having tried very many methods of making this preparation I have found the following one to succeed well. For very fine injections the mixture may be diluted by adding three ounces of glycerine. See also part V.

**178. Prussian Blue Fluid.**—*Composition of the usual Prussian blue fluid for making transparent injections.*

Common glycerine ... ..	1 ounce.
Spirits of wine ... ..	1 ounce.
Ferrocyanide of potassium... ..	12 grains.
Tincture or solution of perchloride of iron*	1 drachm.
Water ... ..	4 ounces.

The ferrocyanide of potassium is to be dissolved in one ounce of the water and glycerine, and the tincture of sesquichloride of iron added to another ounce. These solutions should be mixed together *very gradually* and well shaken in a bottle. *The iron being added to the solution of the ferrocyanide of potassium.* When thoroughly mixed, the solutions should produce a dark blue mixture, in which no precipitate or flocculi are observable. Next, the spirit and the water are to be added very gradually, the mixture being constantly shaken in a large stoppered bottle. The tincture of perchloride of iron is recommended because it can always be obtained of nearly uniform strength. It is generally called the *muriated tincture of iron*, and may be purchased of the druggists. In cases in which a very fine injection is to be made for examination with the highest powers, half the quantity of iron and ferrocyanide of potassium may be used.

It has been remarked that as the colour of *Turnbull's blue* is brighter and is not liable to fade, it is to be preferred to the Prussian blue. The latter does not, however, lose its colour if a little free

\* The Tinctura Ferri Perchloridi and the Liquor Ferri Perchloridi of the British Pharmacopœia, of 1867, are of the same strength and consist of one part of the strong Liquor Ferri Perchlor. to three parts, by measure, of spirit or water.

acid is present in the fluid in which the specimen is preserved. I have many specimens injected with Prussian blue, which have retained their colour perfectly for more than ten years. An advantage of the Prussian blue over other fluids is, that the ingredients required to make it are very cheap, and can be readily obtained everywhere. Capillaries injected with the Prussian blue fluid under high magnifying powers are represented in pl. XXV.

I would most earnestly recommend all who are fond of injecting to employ transparent injections, and to endeavour by trying various transparent colouring matters, to discover several which may be employed for this purpose, for I feel sure that by the use of carefully prepared transparent injecting fluids, many new points in the anatomy tissues will be made out.

**179. Turnbull's Blue.**—My friend, Mr. B. Wills Richardson, of Dublin, has introduced Turnbull's blue in preference to ordinary Prussian blue. Ten grains of pure sulphate of iron are to be dissolved in an ounce of glycerine, or better, in a little distilled water and then mixed with glycerine, and thirty-two grains of ferridcyanide of potassium in another small proportion of water, and the solution mixed with glycerine. These two solutions are then gradually mixed together in a bottle, the iron solution being added to that of the ferridcyanide, and mixture ensured by frequent agitation. The other ingredients are added as in the Prussian blue fluid. This modification may be adopted in all cases in which I have recommended the ordinary Prussian blue. The proportions given in the text are, however, unnecessarily large, and I find that the following makes a good fine injecting fluid.

Ferridcyanide of potassium	...	...	10 grains.
Sulphate of iron	...	...	5 „
Water	...	...	1 ounce.
Glycerine (Price's)	...	...	2 ounces.
Alcohol	...	...	1 drachm.

The iron, dissolved in a little water and mixed with glycerine, is to be added to the solution of the ferridcyanide, as in the preparation of the other fluid.

**180. Carmine Injecting Fluid.**—In the hands of Mr. Smee, Professor Gerlach, and others, a solution of carmine in ammonia has long been employed for making minute injections with the most satisfactory results. The solution may be diluted to the required tint and injected. It is most applicable to injecting very delicate vessels, as those of the brain; indeed, if much force be employed, the fluid

transudes through the walls of the vessels, and tinges all the neighbouring tissues indiscriminately. The fluid is much improved, and its tendency to transude diminished, by the addition of glycerine and a little alcohol.

Professor Gerlach was the first who used a carmine injecting fluid. The beautiful carmine injections now made in Germany are prepared with this fluid, or a slight modification of it. I take the receipt from the excellent work of Dr. Frey (*Das Mikroskop*, 1863).

Carmine...	...	...	...	77 grains.
Water ...	...	...	...	70 grains.
Liquor ammoniaë	...	...	...	8 drops.

The carmine is to be dissolved in the ammonia and water, and the solution left for some days exposed to the air, and then mixed with pure gelatine, made by dissolving a drachm and a-half of good gelatine in a drachm and three quarters of water. Lastly, a few drops of acetic acid are added to the mixture, which is injected warm.

**181. Acid Carmine Fluid.**—After trying a great many different combinations, I arrived at the following, which answers the purpose exceedingly well :—

Carmine	...	...	...	...	5 grains.
Glycerine, with eight or ten drops of	}				$\frac{1}{2}$ ounce.
acetic or hydrochloric acid					
Glycerine	...	...	...	...	1 „
Alcohol	...	...	...	...	2 drachms.
Water	...	...	...	...	6 „
Ammonia,	a few drops.				

Mix the carmine with a few drops of water and, when well incorporated, add about five drops of *liquor ammoniaë*. To this dark red solution, about half an ounce of the glycerine is to be added, and the whole well shaken in a bottle. Next, very gradually, pour in the acid glycerine, frequently shaking the bottle during admixture. Test the mixture with blue litmus paper, and if not of a very decidedly acid reaction, a few drops more acid may be added to the remainder of the glycerine, and mixed as before. Lastly, mix the alcohol and water very gradually, shaking the bottle thoroughly after adding each successive portion, till the whole is mixed. This fluid, like the Prussian blue, may be kept ready prepared, and injections may be made with it very rapidly.

**182. Dr. Carter's Carmine Injecting Fluid.**—For a carmine injecting fluid which will run perfectly freely through the most minute capillaries, and one that will not tint the tissues beyond the vessels themselves, Dr. Carter has found the following formula to answer satisfactorily:—

Pure carmine	...	...	...	60 grains.
Liq. ammon. fort. (P. B.)	...	...	...	120 „
Glacial acetic acid	...	...	...	86 minims.
Solution of gelatin (1 to 6 water)				2 ounces.
Water	...	...	...	1½ „

The carmine is to be dissolved in the solution of ammonia and filtered, if necessary. With this mix thoroughly an ounce and a half of the hot solution of gelatine. The remaining half ounce of gelatin is to be mixed with the acetic acid, and dropped, little by little, into the solution of carmine, stirring briskly during the whole time. (Archives of Medicine, vol. III, p. 287).

This fluid is admirably adapted for specimens which are to be mounted in Canada balsam, but not for those to be preserved in glycerine. The vessels are well displayed, but all the delicate nerve fibres are invisible.

Transparent injecting fluids of several different colours are very much to be desired, but although many experiments have been made in the hope of obtaining such, we are, as yet, restricted to two, the blue and the red. Thiersch has succeeded in making others, the composition of one of which, yellow, is given below. I have not myself met with much success hitherto in the use of these fluids, for if I employ them according to the directions given, I am unable to demonstrate the masses of germinal matter (nuclei), and various points of importance; and when made according to the principles followed in the case of the Prussian blue fluid, the results are by no means satisfactory, and as the colour is, in many cases, affected by acids, the subsequent steps of my process are interfered with. See part V. They may, however, be useful to those who prefer to follow out other plans of investigation.

An injecting fluid of a greenish tint may be made, according to the directions given in page 94, for Turnbull's blue, by employing different proportions of the ingredients,—1 grain or less of the sulphate of iron to 10 grains of the ferricyanide of potassium.

Thiersch (Das Mikroskop, 1865, von Dr. H. Frey) prepares a transparent yellow injecting fluid as follows:—



A.—A solution of bichromate of potash is made, in the proportion of one part of salt to two of water.

B.—A solution of nitrate of lead of the same strength.

One part of solution A is placed in a small basin and mixed with 4 parts of a concentrated solution of gelatine. Two parts of solution B are placed in another basin and mixed with four parts of jelly.

These are to be slowly and thoroughly mixed together at a temperature of from  $75^{\circ}$  to  $90^{\circ}$ , and then heated in a water-bath at a temperature of about  $212^{\circ}$  for half an hour or more. The mixture is then to be carefully filtered through flannel.

**183. Of Injecting Different Systems of Vessels with Transparent Injections.**—The transparent injecting fluids which may be used for double injections, must have the same reaction. Thus the Prussian blue fluid, and the carmine solution without gelatine, p. 95, may be used for this purpose; but I have not yet been able to obtain other colours which answer so well as these. Good transparent yellow and green *acid* injecting fluids which might be used for double injections in cases in which the Prussian blue fluid was employed, are much to be desired.

**184. New Form of Soluble Prussian Blue.**—Brücke recommends the following:—

Ferrocyanide of potassium, 217 grammes, dissolved in 1 litre of distilled water.

Perchloride of iron, 10 grammes in 1 litre of distilled water.

Sulphate of soda, a cold saturated solution.

One volume of each of the two first solutions is to be mixed with one volume of the soda solution. The iron and soda solution is then to be mixed gradually with the ferrocyanide and soda solution with constant stirring. The mixture is to stand for some hours, and the deposit collected on a filter. The deposit is then washed with small quantities of distilled water, until the filtrate runs through quite blue. The blue powder thus prepared is quite soluble (?) in distilled water. Brücke recommends that this be made into an injection with sufficient gelatine to ensure it setting into a jelly. After injection the preparation is to be thrown into spirit, and then hardened in 90 per cent. of alcohol!—a process which it may be remarked will effectually destroy many delicate structures, and entirely alter all. Brücke states that the fluid bears chromic acid and bichromate of potash well, but says that all fluids containing glycerine must be carefully avoided!

The student may inject with this mixture, and then try the Prussian blue fluid recommended in p. 93, and compare the results.

**185. Mercurial Injections** are not much used for microscopical purposes, although mercury was much employed formerly for injecting lymphatic vessels and the ducts of glandular organs. The pressure of a column of mercury a few inches in height is alone sufficient to force some into the vessels. The mercurial injecting apparatus consists of a glass tube, about half an inch in diameter and twelve inches in length, to one end of which has been fitted a steel screw to which a steel injecting pipe may be attached. The pipes and stopcocks must be made of steel, for otherwise they would be destroyed by the action of the mercury.

*Of Injecting the Vessels of the Higher Animals.*

**186. Of the Practical Operation of Injecting.**—It is generally stated that a successful injection cannot be made until the muscular rigidity which comes on shortly after death, and which affects the muscular fibres of the arteries as well as those of the muscles themselves, has passed off; but I have found that most perfect injections may be made before the muscles begin to contract, that is, within a few minutes after the death of the animal. All my fine injections have been made less than five minutes after death.

The student will find that the process of injecting will be learnt after a few trials, and although he may quite fail in the first attempts he makes, I earnestly recommend him not to give up, for this mode of investigation is of the greatest advantage, and by it we learn facts of great anatomical importance. Every one engaged in the investigation of the anatomy of tissues in health and disease, should be able to inject well, and by employing the fluids recommended, it will be found that injections can be made without much sacrifice of time.

The steps of the process of transparent injection are very similar to those taken in making the opaque injections, except that when size is employed, the specimen must be placed in warm water until warm through, otherwise the size will solidify in the smaller vessels and the further flow of the injecting fluid will be prevented. Soaking for many hours is sometimes necessary for warming a large preparation through, and it is desirable to change the warm water frequently. The size must also be kept warm, strained immediately before use, and well stirred up each time the syringe is filled.

In the first place the following instruments must be conveniently arranged :—

The syringe thoroughly clean and in working order, with pipes,

stop-cocks, and corks. One or two scalpels. Two or three pairs of sharp scissars. Dissecting forceps. Bull's nose forceps. Curved needle threaded with silk or thread, the thickness of the latter depending upon the size of the vessel to be tied. Wash-bottle. Injecting fluid in a small vessel. Plenty of warm water if the injection is to be made with fluid containing size or gelatin.

The student is recommended to practise the process by injecting the organs and animals in the order in which they are enumerated, and not to attempt the second until he has succeeded with the first. In all cases the operation is to be conducted patiently, and very slight pressure on the piston is to be exerted.

1. Kidneys of sheep or pig.—*Artery*.

2. Eye of ox.—*Artery*.—Two or three minutes will be time enough to make a complete injection. If the globe becomes very much distended by the injecting process, an opening must be made in the cornea which will permit the humours of the eye to escape, and thus space will be left for the injection, and the vessels may be completely distended.

3. Rat, mouse, frog.—*Injected from the aorta*.

4. Portion of intestine.—*Branch of artery*. All divided vessels being tied before commencing to inject, pl. XXV, fig. 164.

5. Liver. In one part a *branch of duct*; in a second, a *branch of artery*; in a third, *portal vein*; and in a fourth, *hepatic vein*. The portal and hepatic vein, the artery and portal or hepatic vein, or the duct and portal vein may be injected with injections of different colours in one piece of liver.

Suppose the student is about to inject a frog. An incision is made through the skin, and the sternum divided in the middle line with a pair of strong scissars; the two sides may easily be separated, and the heart is exposed. Next the sac in which the heart is contained (pericardium) is opened with scissars, and the fleshy part of the heart seized with the forceps; a small opening is made near its lower part, and a considerable quantity of blood escapes from the wound—this is washed away carefully by the wash-bottle p. 86. Into the opening—the tip of the heart being still held firmly by the forceps,—a pipe is inserted and directed upwards towards the base of the heart to the point where the artery is seen to be connected with the muscular substance. *Before the pipe is introduced, however, a little of the injecting fluid is drawn up so as to fill it*, for if this were not done, the air contained in the pipe would necessarily be forced into vessels, and the injection would fail. The point of the pipe can with very little difficulty be made to enter the artery. The needle with the thread is next carried round the vessel, and the

thread seized with forceps, the needle unthreaded and withdrawn, or one end of the thread may be held firmly, while the needle is withdrawn over it in the opposite direction. The thread is now tied over the vessel, so as to include the *tip of the pipe only*, for if the pipe be tied too far up, there is great danger of its point passing through the delicate coats of the vessel.

The syringe having been well washed in warm water before commencing, its nozzle is plunged beneath the surface of the injecting fluid, the piston moved up and down two or three times, so as to force out the air completely, and the syringe filled with fluid. It is then connected with the pipe,—which is firmly held by the finger and thumb of the left hand,—with a screwing movement. A little of the injection is, however, first forced into the wide part of the pipe so as to prevent the possibility of any air being included.

The pipe and syringe being still held by the left hand, the piston is slowly and gently forced down with a slightly screwing movement with the right, care being taken not to distend the vessel so as to endanger rupture of its coats. The handle of the syringe is to be kept uppermost, and the syringe should never be completely emptied, in case of a little air remaining, which would thus be forced into the vessel, fig. 154, pl. XXIII. The injection is now observed running into the smaller vessels in different parts of the organism.

**187. Of the Pressure required for Successful Injection.**—The requisite amount of pressure for forcing the injection into the finest capillaries may be obtained without using the syringe. 1. By employing a long tube, to one end of which is attached a small piece of India-rubber tube furnished with a stop-cock which fits into the injecting pipe. 2. By placing the injecting fluid in a vessel three or four feet above the table and immersing a syphon tube which may be entirely composed of India-rubber or partly of glass. 3. By arranging a glass vessel upon the principle of the wash-bottle, p. 86, pl. XXIII, fig. 153, pressure upon the surface of the liquid being produced by the aid of an India-rubber bottle compressed by a weight or spring, or by pouring mercury into the tube which reaches nearly to the bottom of the flask. The other tube must of course also dip below the surface of the injecting fluid while to its upper free end a piece of India-rubber tubing provided with a stop-cock at its extremity, must be adapted. Other arrangements have also been proposed, but after having tried many different plans, I find that upon the whole, the ordinary injecting syringe is the most successful as well as the cheapest, the most convenient, and the most simple instrument, and it is most easily kept in perfect order. It need scarcely be said that by no mechanical means can such varieties of pressure be obtained as by

the aid of the muscles of the hand and arm, and the pressure can be modified instantly, according to the judgment of the operator.

**188. Of Injecting the Ducts of Glands.**—The modes of injecting which have just been considered, although applicable to the injection of vessels, are not adapted for injecting the ducts and glandular structure of glands; for as the ducts usually contain a quantity of the secretion, and are always lined with epithelium, it happens that when we attempt to force fluid into the duct, the epithelium and secretion are driven towards the secreting structure of the gland, which is thus effectually plugged up with a material which is colourless. There is therefore no hope of making out the origin of the ducts and their relation to the secreting structure. It is obviously useless to introduce an injecting fluid, for the greatest force which could be employed would be insufficient to drive the contents of the follicles and ducts through the basement membrane, and the only possible result of such an attempt would be rupture of the thin walls of the secreting structure and extravasation of the contents. As I have before mentioned, partial success has been obtained by employing mercury, but the preparations thus made are not adapted for microscopical observation.

I had long felt very anxious to inject the ducts of the liver in order to ascertain the manner in which they commenced in the lobule, and the precise relation which they bore to the liver cells. This has long been a point of dispute among microscopical observers, and many different and incompatible conclusions have been arrived at by different authorities. In order to prove the point satisfactorily it was obviously necessary to inject the ducts to their minute ramifications, which no one, as far as I was able to ascertain, had succeeded in doing satisfactorily. After death the minute ducts of the liver always contain a little bile. No force which can be employed is sufficient to force this bile through the basement membrane, for it will not permeate it in this direction. When any attempt is made to inject the ducts, the epithelium and mucus, in their interior, form with the bile an insurmountable barrier to the onward course of the injection. Hence it was obviously necessary to remove the bile from the ducts before one could hope to make a successful injection. It occurred to me, that any accumulation of fluid in the smallest branches of the portal vein or in the capillaries, must necessarily compress the ducts and the secreting structure of the liver which fill up the intervals between them. The result of such a pressure would be to drive the bile towards the large ducts and to promote its escape. Tepid water was, therefore, injected into the portal vein. The liver became greatly distended, and bile, with much ductal epithelium, flowed by

drops from the divided extremity of the duct. The bile soon became thinner owing to its dilution with water which permeated the intervening membrane, and entered the ducts. These long narrow highly tortuous channels were thus effectually washed out from the point where they commenced as tubes not more than 1-3000th of an inch in diameter, to their termination in the common duct, and much of the thick layer of epithelium lining their interior was washed out at the same time. The water was removed by placing the liver in cloths with sponges under pressure for twenty-four hours or longer. All the vessels and the duct were then perfectly empty and in a favourable state for receiving injection. The duct was first injected with a coloured material. Freshly precipitated chromate of lead, white lead, vermilion, or other colouring matter may be used, but for many reasons to which I have alluded, the Prussian blue injection is the one best adapted for this purpose. It is the only material which furnishes good results when the injected preparations are required to be submitted to high magnifying powers. Preparations injected in this manner should be examined as transparent objects, p. 90. They may be mounted in the ordinary preservative fluids or in Canada balsam, but glycerine forms the most satisfactory medium for their preservation.

I have recently succeeded in making most perfect injections of the ducts of the liver which demonstrate conclusively the cell containing network of the lobule and its connection with the finest gall ducts. The injection may be seen around the hepatic cells as they lie in the tubes of the network.

**189. Of Injecting Lymphatic Vessels.**—It is very difficult to find and insert a pipe into a lacteal or lymphatic vessel. When it is desired to inject these tubes it is usual to insert the pipe into the large trunk of the thoracic duct. I have, however, found that by injecting water into the *blood vessels*, the lymphatics and lacteals of a part of the body or of an organ become distended by the transudation of the fluid, and in this distended state it is easy to insert the pipe. The pipe having been tied in the vessel, the water is absorbed as described in § 188, and the injection may then be forced in, care being taken to use very gradual pressure, so that the coats of the lacteal or lymphatic may be sufficiently stretched to allow the injection to pass between the valves, *without being ruptured*. In this way I have succeeded in making beautiful injections of the finest lymphatics of the liver. (Archives, vol. I, p. 113.) Pl. XXIV, fig. 160.

Sometimes lymphatics may be injected by extravasation from a duct and more rarely from a vessel. I have often injected the lymphatics of the liver when forcing the injection into the duct.

Some observers think they have succeeded in injecting very minute lymphatic vessels and demonstrating that these are continuous with the capillaries. Such lymphatics are considered to ramify in the intervals between epithelial cells. It is, however, doubtful if the facts observed have been correctly interpreted.

#### OF INJECTING THE LOWER ANIMALS.

**190. Insects.**—Injections of insects may be made by forcing the injection into the general abdominal cavity, whence it passes into the dorsal vessel and is afterwards distributed to the system. The superfluous injection is then washed away, and such parts of the body as may be required, removed for examination. Insects should be injected very soon after they have emerged from the pupa.

The water vascular apparatus, the vessels, and the digestive tube may be injected in many of the lower animals. In some cases the best results will be obtained with size coloured with transparent colouring matter; in others it will be found better to employ the Prussian blue or carmine injecting fluid made with glycerine, p. 95. In injecting the digestive apparatus of some entozoa as the liver-fluke, the pipe may be tied in, but as a general rule it is only necessary to make an opening into the vessel and insert the pipe which must be held steadily while the injection is carefully forced from the orifice. In many fine injections a pipe of the form represented in pl. XXIII, fig. 157, with a blunt point and a lateral opening will be found of great advantage. Coloured fluids will rise in the vessels of most plants by capillary attraction, and occasionally the vessels of some of the tissues of animals may be partially injected in the same way.

**191. Mollusca.** (Slug, snail, oyster, &c.)—The tenuity of the vessels of many mollusca renders it undesirable to tie the pipe in them. The capillaries are, however, usually very large, so that the injection runs readily. In different parts of the bodies of these animals are numerous lacunæ or spaces, which communicate directly with the vessels. If an opening be made through the integument of the muscular foot of the snail, a pipe may be inserted, and thus the vessels may be injected from these lacunæ with comparative facility. The large vessels of the branchiæ may be readily injected with the aid of a pipe of the form represented in pl. XXIII, fig. 157.

Milne Edwards injected the snail by passing the pipe through an opening made with a sharp instrument at the base of the tentacle.

In this case the injecting fluid passes into lacunæ or spaces and fills the venous system, but as has been shown by Mr. Robertson, of Oxford, the arteries are not injected by this method (On the Organs of Circulation of the Roman Snail, *Helix Pomatia*. *Annals and Magazine of Natural History*, January, 1867).

**192. Mr. Robertson's Plan of Injecting the Snail.**—This skilful anatomist recommends another plan of proceeding. The snails are to be killed by drowning them in a jar quite filled with cold water, the mouth being closed with a piece of plate glass.

The vascular system is to be injected from the ventricle of the heart with size and carmine. The heart of the snail is easily found. It is enclosed in a sac which is situated at the posterior extremity of the pulmonary chamber on the left side. The position of the organs of the snail has been fully described by Dr. Lawson, in a paper published in the *Mic. Journal* for January, 1863. The injection introduced into the heart passes right round the body and returns to the pulmonary chamber. By this plan the arterial branches may be traced into the foot and to many other parts which were considered to be destitute of arteries. Mr. Robertson has arrived at the conclusion that in snails there exists a *closed capillary system communicating directly with the arteries on the one hand and the veins on the other as in the higher animals*; and he has completely failed to demonstrate the existence of any direct communication between the spaces or lacunæ in the various tissues and the vascular system. It is probable that in the mollusca the capillaries are arranged as in the higher animals, but they are wider, and their walls being so very thin it requires great skill to inject them without extravasation.

**193. Injecting Fishes.**—The vessels of fishes are exceedingly tender, and great caution is required in filling them. It is often difficult or quite impossible to tie the pipe in the vessel of a small fish. If we attempt to inject from the heart, the injection passes to the gills, but it is seldom that it runs through these and penetrates the systemic vessels. It is usual therefore to proceed thus,—the tail of the fish is to be cut off, and the pipe introduced into the divided vessel which lies immediately beneath the spinal column. In this simple manner beautiful injections of a fish may sometimes be made. In small fishes in which the vessels are too delicate to be tied, a good injection may be made by simply placing the pipe in the vessel. As the fluid is so cheap, a considerable loss is of no importance.

**194. Of Preparing Portions of Injected Preparations for Microscopical Examination.**—Preparations made by injecting colouring matters suspended in water or gelatine may be mounted in various preservative fluids, or dried and placed in balsam. When thin



tissues, such as the mucous membrane of the intestines or other parts, have been injected, it is necessary to lay them perfectly flat, and wash the mucus and epithelium from the free surface, either by forcing a current of water from the wash-bottle, or by placing them in water and brushing the surface gently with a camel's hair brush. Pieces of a convenient size may then be removed and mounted in solution of naphtha and creosote, in dilute alcohol, in glycerine, or in gelatine and glycerine. The most important points in ordinary injections may be shown if the preparation be dried and mounted in Canada balsam. The specimen must, in the first place, be well washed and floated upon a glass slide with a considerable quantity of water, which must be allowed to flow off the slide very gradually. It may then be allowed to dry under a glass shade, in order that it may be protected from dust. The drying should be effected at the ordinary temperature of the air, but it is much expedited if a shallow basin filled with sulphuric acid be placed with it under the same bell-jar, p. 76, pl. XX, fig. 131.

Of solid organs, such as the liver and kidney, thin sections from the interior made in different directions, as well as portions from the surface should be preserved. Thin sections may be made with the ordinary scalpel or with Valentin's knife, if an extensive one be required. The surfaces of the section should be well washed, and it may then be mounted in one of the methods previously described.

Specimens which have been injected with Prussian blue or carmine injecting fluids, the composition of which is given in pp. 93, 95, must be preserved in glycerine containing a trace of free acetic acid (5 to 15 drops to the ounce). The advantage of this plan is that it enables us not only to observe the arrangement of the vessels, but also to study all the other structures entering into the composition of the tissue or organ.

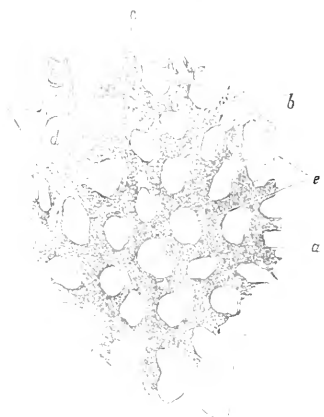
#### *Injections as Moist Specimens and Mounted in Canada Balsam.*

The observer will be surprised at the great differences observed in the same texture according to the method in which it is prepared. I have already adverted to the objections of mounting moist tissues in balsam. Although most observers in Germany still pursue this plan for preserving their injections, it will be condemned as unsatisfactory by any one who has tried the method of mounting the specimen moist in strong glycerine. Not only are the nuclei of the vessels for the most part destroyed by the process of mounting in balsam, but many very important elements of the tissue, and especially nerve fibres, are so changed that they cannot be recognised, or are completely obliterated. The capillaries themselves are so shrunk and changed that very wrong conclusions would be arrived

at if balsam specimens only are submitted to examination. In figs. 165 and 166, pl. XXV, specimens of the very same tissue are represented prepared according to the different plans referred to, but magnified by the same powers. Let the reader observe the different diameter of the vessels and note how many points are displayed in the moist preparation which are not to be demonstrated in the one preserved in balsam. I feel, therefore, compelled to reject inferences arrived at from the examination of balsam specimens, and strongly advise the student not to be misled by their mere sharpness and bright colour. Such preparations undoubtedly enable us to form a general idea of the arrangement and number of the capillaries in different textures, and in this respect are of value, but they are useless if we wish to learn facts concerning the relation of the capillaries to the texture lying in their meshes, the structure of the vessels themselves, or that of the tissues in which they ramify.

**195. Of the best Mode of Destroying the Life of Animals intended for Injection.**—I have tried various plans of destroying animals intended for minute injection, and have found that in death by sudden shock the vessels remain in a relaxed state for a sufficient time after death to enable us to complete the injection. In some cases a good result is gained by destroying life in an atmosphere of carbonic acid, but I find that the very sudden death produced by a fall from a height, dashing on the ground, &c., is the most advantageous. Any small animal may be wrapped up in a cloth and thrown suddenly and with some force upon the ground. In order to avoid rupturing any of the tissues the animal must be protected by several folds of the cloth. Swinging very rapidly through the air also destroys life very suddenly, without causing that sudden contraction of the muscles, which seriously interferes with successful injection.

Good injections may be made after the *rigor mortis* has entirely passed off, and formerly no attempt was made to inject before this period. But when the muscles have again become relaxed the finer branches of the nerves will be found softened or entirely destroyed, and many delicate structures so much altered that it would not be possible for any one who was acquainted with their natural appearance to recognise them. Hence it is useless to put off the operation of injection if we desire to demonstrate in the specimens more than the arrangement of the capillaries only.



4403



Micrograph showing a dense network of vessels with thick, irregular walls, possibly representing a pathological state of the vascular system.

Micrograph showing a highly detailed and complex vascular network with many small vessels and some larger, more prominent structures, possibly a high-magnification view of a capillary bed.



## OF STAINING TISSUES.

The plan of staining tissues artificially, is one from which the greatest advantages have been derived already, and it is quite certain that, by modifications of the processes now employed, many new and most important facts will be discovered. It is, however, important that the student should bear in mind that the process of staining may be employed for two very different purposes.

1. For colouring the *living or germinal matter* of the cell or texture.
2. For demonstrating peculiarities in the build of the *formed material, cell wall, intercellular substance* or *tissue*, and for ascertaining the order in which the several parts of which it is composed have been laid down.

**196. Of Colouring the Germinal or Living Matter.**—This living matter is in all cases perfectly clear and transparent. It never exhibits structure, and is invariably colourless. It possesses an acid reaction, or, to speak more correctly,—an acid reaction is always developed immediately after its death. Hence if an alkaline solution of colouring matter from which the colour may be precipitated or fixed by an acid, be caused to pass into germinal matter which has recently died but has not yet undergone decomposition, the alkali is neutralised by the acid present, and the colour is retained. It is probably precipitated in a state of very minute subdivision, or combined with some of the constituents of the germinal matter to form a compound insoluble in weak acids.

The tissue itself or formed material being ordinarily bathed with an alkaline fluid does not take the colour, and hence by carrying out the process with due care the *germinal or living matter may always be coloured while the formed material or tissue remains perfectly colourless*. Any one can satisfy himself of this fact by placing upon a glass slide a few liver cells from any animal immediately after its death. If a drop or two of the solution of carmine in ammonia be allowed to flow over the cells, the nucleus or mass of germinal matter of each cell will be tinted in the course of a few seconds, while the outer part of the cell will not be affected.

Staining the germinal matter may be carried out long after the death of the animal if the development of an alkali by decomposition be prevented by alcohol or some other preservative fluid. Specimens should be immersed in a preservative fluid *immediately after death*. In practice, however, it is always better to carry out the staining process at once.

It must not be inferred that animal matter can be stained by

alkaline colouring fluids only. Solutions of an acid reaction may be employed if the germinal matter be rendered alkaline in the first instance by soaking the texture in a weak solution of ammonia. I have prepared some beautiful specimens as follows :—An alkaline solution was injected into the vessels, and after allowing twelve hours or more for the tissues to become thoroughly permeated, the finest Prussian blue fluid, *see* part V, was introduced. The latter passed into the very substance of the germinal matter, which was tinged much more deeply than the surrounding substance. The liver cell may be thus impregnated with the blue in every part. It seems probable that by prosecuting more detailed enquiries in this direction, we may learn something concerning the physical arrangement of the matter constituting the formed material. Specimens prepared in this way enable us to prove the unsoundness of the old notion concerning the supposed cell wall and cell contents ; but in endeavouring to draw correct inferences regarding the natural arrangement of the parts prepared in this way, it must not be forgotten that the alkaline ammonia may have effected alterations in the formed material, and modified its structure in an important manner.

**197. Process of Staining followed by the Rev. Lord S. G. Osborne.**

—Welcker was, I believe, one of the first observers to employ a solution of carmine for the purpose of staining the nuclei of tissues, and Gerlach was an early and most successful advocate of this plan. It has been, but I think wrongly, stated, that Gerlach was the first who employed this process. The date of Gerlach's work is 1853 (*Mikroskopische Studien aus dem Gebiete der Menschlichen Morphologie*. Erlangen). But in June, 1856, the Rev. Lord S. G. Osborne showed that nuclei were more deeply tinged by carmine than other parts of the cell. (*Vegetable Cell Structure and its Formation*, as seen in the early stages of the Growth of the Wheat Plant). *See* also the plate accompanying this paper (*Trans. Mic. Soc.*, vol. V, pl. IV, 1856). Lord Osborne allowed the plants to *grow* in the carmine solution. The growing parts were stained most successfully.

**198. Gerlach's Method of Staining.**—Gerlach used first a concentrated solution of carmine in ammonia, and placed the sections of brain and spinal cord previously hardened by chromic acid, in the carmine fluid for from ten to fifteen minutes. They were then well washed in water for some hours, and treated with acetic acid. The water and acid were removed by immersion in alcohol. The sections were afterwards mounted in Canada balsam. Gerlach found that dilute solutions (two or three drops of the ammoniacal solution of carmine to an ounce of water), and maceration for *two or three days*, afforded better results.

**199. The Author's Carmine Fluid** for staining the germinal matter is made as follows :—

- Carmine, 10 grains.
- Strong liquor ammonia,  $\frac{1}{2}$  drachm.
- Price's glycerine, 2 ounces.
- Distilled water, 2 ounces.
- Alcohol,  $\frac{1}{2}$  ounce.

The carmine in small fragments is to be placed in a test tube, and the ammonia added to it. By agitation, and with the aid of the heat of a spirit-lamp, the carmine is soon dissolved. The ammoniacal solution is to be boiled for a few seconds and then allowed to cool. After the lapse of an hour, much of the excess of ammonia will have escaped. The glycerine and water may then be added and the whole passed through a filter or allowed to stand for some time, and the perfectly clear supernatant fluid poured off and kept for use. This solution will keep for months, but sometimes a little carmine is deposited, owing to the escape of ammonia, in which case one or two drops of liquor ammonia may be added to the four ounces of carmine solution.

The rapidity with which the colouring of a tissue immersed in this fluid takes place, depends partly upon the character of the tissue and partly upon the excess of ammonia present in the solution. If the solution be very alkaline the colouring will be too intense, and much of the soft *tissue* or imperfectly developed formed material around the germinal matter, is destroyed by the action of the alkali. If, on the other hand, the reaction of the solution be neutral, the uniform staining of tissue and germinal matter may result, and the appearances from which so much may be learnt are not always produced. When the vessels are injected with the Prussian blue fluid the carmine fluid requires to be sufficiently alkaline to neutralise the free acid present. The permeating power of the solution is easily increased by the addition of a little more water and alcohol. In some cases the fluid must be diluted with water, alcohol, or glycerine, and the observer must not hastily condemn the process, or conclude as some have, that a particular form of germinal matter is not to be coloured until they have given the plan a fair trial and tried a few experiments.

Notwithstanding the advantages of the above plan and its success in the hands of many observers, objections have been urged against it by some who, I venture to think, have not made themselves familiar with the details of the method. It has been said that the formed material may be stained as well as the germinal matter. As every one must know, almost any tissue may be stained. Hair, horn, wool, paper, &c., may be deeply dyed, even after they have been

dried. The important fact, however, is this, that the germinal matter of a tissue may be deeply coloured, although the formed material which must be traversed by the staining fluid in the first instance is not stained at all. This is the case with all germinal matter, and it seems to me a fact of far higher significance than is generally admitted. By the process of investigation described it becomes possible not only to distinguish germinal matter in all cases, but to show definitely the mode of formation of the tissue. And in many instances we can determine which is the oldest and which the youngest portion of the tissue.\*

**200. Thiersch's Carmine Fluid.**—Frey (Das Mikroskop) gives Thiersch's fluids for colouring tissues by carmine.

Carmine, 1 part.  
Caustic ammonia, 1 part.  
Distilled water, 3 parts.  
This solution is to be filtered.  
Oxalic acid, 1 part.  
Distilled water, 22 parts.

One part of the carmine solution is to be mixed with 8 parts of the oxalic acid solution, and 12 parts of absolute alcohol are to be added.

If the solution is orange-coloured instead of dark red, more ammonia is required, and the orange becomes red. The orange colour may also be used for staining. If crystals of oxalate of ammonia become formed they must be separated by filtration.

**201. Thiersch's Lilac Colouring Fluid.**—

Borax, 4 parts.  
Distilled water, 56 parts.  
Dissolve and add, of carmine, 1 part.

The red solution is to be mixed with twice its volume of absolute alcohol, and filtered. The precipitate of carmine and borax is redissolved in distilled water and is ready for use. It colours more slowly than the red solution.

**202. Anilin Colours.**—The beautiful reds and blues which have been lately so largely used as dyes, popularly known in this country as Magenta and Solferino, have been much employed by microscopists. The colour is not very soluble in water, but is readily dissolved by

\* In a paper on the ova of the stickleback (*Microscopical Journal*, Jan. 1867), Dr. Ransom has expressed himself against the plan of investigation I have followed. His objections, however, are not valid, and some of the remarks he has made prove, I think, that he has not succeeded in preparing specimens according to my method. I have replied to some of my friend's statements in a subsequent number of the journal.



alcohol. A grain of the colour, ten or fifteen drops of alcohol, and an ounce of distilled water, make a dark red solution ; or the colour may be boiled in water, allowed to cool, and then filtered. This fluid colours tissues very readily. Many exceedingly delicate and perfectly transparent textures, which are almost invisible in the natural state, can be most satisfactorily demonstrated by the use of this coloured fluid. The cilia of ciliated epithelium may be tinted while they continue to vibrate. As the substance of the cell becomes coloured, however, the action of the cilia ceases. Every kind of cell wall, delicate membrane, and transparent tissue may be tinted with these colours.

Magenta has been recommended by Dr. Roberts for showing a minute spot connected with the red blood corpuscles of man. ("On peculiar appearances exhibited by blood corpuscles under the influence of solutions of magenta and tannin"—*Proceedings of the Royal Society*, vol. XII, p. 481, No. 55, April, 1863). The peculiar action exerted by magenta and tannin upon the red blood corpuscles has not yet been satisfactorily explained, but my friend, Dr. Hughes Bennett, of Edinburgh, tells me that, with the aid of very high powers, he has been able to demonstrate that the minute spot appearing after the blood corpuscles have been soaked in magenta exhibits angles, and he considers that it is in fact a minute crystal which has formed upon the corpuscle.

**203. Blue Colours for Staining.**—Thiersch recommends the following fluid, the composition of which I take from Frey :—

Oxalic acid, 1 part.

Distilled water, 22 parts.

Indigo carmine, as much as the solution will take up.

Another solution of oxalic acid and water in the same proportion is required. One volume of the first solution is mixed with two volumes of the last and nine of absolute alcohol. The mixture is then filtered, and is ready for use.

An anilin blue fluid may be made as follows :—

Soluble anilin blue,  $\frac{1}{2}$  grain.

Distilled water, 1 ounce.

Alcohol, 25 drops.

This fluid is not acted upon by acids or alkalis. Frey strongly recommends a fluid of this description as very useful for colouring many tissues.

**204. Tannin.**—Although tannin does not colour animal membrane, it alters its character to such an extent as to enable us to see many

peculiar points of structure or arrangement not visible before, or it produces a chemical change upon the substance, from which we gain important information. Solutions of magenta and solutions of tannin have been much used in investigations upon the blood corpuscles. The action of tannin upon the red blood corpuscle is very peculiar; it has been specially studied by Dr. Roberts, of Manchester ("On peculiar appearances exhibited by blood corpuscles under the influence of solutions of Magenta and Tannin"—*Proceedings of the Royal Society*, vol. XII, p. 481, No. 55, April, 1863). The solution is made by dissolving 3 grains of tannin in an ounce of distilled water. One drop of blood may be mixed with four or five drops of the tannin solution and a portion of the mixture examined under the microscope.

**205. Solutions of Nitrate of Silver.**—Of late years nitrate of silver has been used for staining tissues. Recklinghausen and His have employed this plan with great success. A weak solution may be imbibed by delicate tubes, and part being precipitated in the tube, perhaps as a chloride or in combination with some albuminous material, subsequently becomes decomposed by the action of light, and a very dark line results, and thus the position of a previously perfectly invisible channel is clearly demonstrated. The *outlines* of epithelial cells and the *intervals* between them may be demonstrated by this process. Transparent connective tissue and the *outer part of cells* can thus be coloured, the *nuclei remaining perfectly colourless and transparent*. The nuclei by longer immersion will also be coloured.\* The appearances may be made to vary very much by modifying the mode of procedure and the time which the preparation is allowed to remain in the solution. After soaking in the nitrate of silver solution for some time the specimen must be placed in distilled water, or in a weak solution of common salt, in order to wash away the nitrate which adheres to the surface or occupies the intervals between the cells. When this has been effected the specimen is exposed to daylight or sunlight until the requisite degree of blackening has been obtained. The strength of the solution employed may be varied according to circumstances. Recklinghausen uses a very dilute solution, consisting of 1 part of nitrate of silver to 400—800 of distilled water.

The structure of the cornea has been recently investigated by His, after the tissue had been prepared according to this plan. The so-called 'intercellular substance' (formed material) only may be coloured, or, after the whole structure has been thoroughly impregnated with

\* The nuclei (germinal or living matter) as long as they are alive resist the action of the fluid, but when they die it is imbibed by them.

the solution, it may be soaked out of the formed material, while that taken up by the nuclei (masses of germinal matter) is retained, and may be decomposed by being exposed to light. In this case the nuclei appear very dark and surrounded by a pale brown formed material. His thinks that when the nuclei are coloured, the precipitate of chloride of silver in the formed material is re-dissolved and absorbed by the nuclei, in which it is afterwards reduced by the action of the light.

**206. Solutions of Chloride of Gold.**—Weak solutions of perchloride of gold have been much used of late years for colouring nerve fibres, which after exposure to light exhibit a blue or violet tinge. A solution containing from  $\cdot 2$  to  $1$  per cent. in distilled water should be made. The tissue after having been soaked till it becomes straw-coloured is to be washed, and then placed in very dilute acetic acid containing  $1$  per cent. or less. The nerves become coloured in the course of a few hours. By this plan Cohnheim professes to have made out very fine nerve fibres, which, he says, pass from the plexuses in the cornea to intervals between the cells of the conjunctival epithelium, and after reaching the surface of the structure end in terminal free extremities. I think, however, we should receive such statements with the utmost caution, and although Professor Kölliker has accepted the view, I cannot adopt it without much stronger evidence than has yet been advanced in its favour. Many considerations make me think it will turn out to be incorrect. Cohnheim's drawings alone excite doubt in my mind concerning the accuracy of his observations, and, at least in my hands, the mode of preparation recommended has not afforded results nearly so satisfactory as I have obtained by other methods of investigation.

**207. Solution of Osmic Acid** ( $\text{Os. O}_4$ ) has been strongly recommended for demonstrating delicate nerve structures by MM. Schultze and Roudneff, because it tinges the white substance of Schwann and Myelin entering into the formation of various kinds of nerve fibres, of a very dark colour or almost black. Other textures are neither coloured so quickly nor so intensely, and often exhibit only a brownish tint. So that by this substance nerve fibres ramifying in various textures may be stained and thus distinguished from other elements of the tissue. Solutions of various strengths may be employed, but one part of osmic acid in 100 of water is stated to be strong enough to produce the desired effect. These processes are capable of almost endless modification.

I have also tried this plan, but have gained nothing by its use. I can show finer nerves clearly by other methods, which I could not demonstrate either by the gold or osmic acid solutions.

**208. Other Metallic Salts.**—Tissues may also be impregnated with solutions of other metallic salts. Acetate of lead has often been employed. The tissue may be soaked for some time in a weak solution, or a weak solution with a little glycerine may be injected. When the tissues are well saturated, thin sections may be made, and, after having been slightly washed, they may be placed in a dilute solution of glycerine, through which sulphuretted hydrogen may be passed. Living plants will take up solutions of various metallic salts, which may then be precipitated in the textures or in the channels by the appropriate reagents.

**209. Modification of the foregoing Plans.**—The observer will perceive that these processes are capable of being modified in many ways. Every one engaged in a special investigation, will naturally try various modes of preparation. Having decided upon one which seems to offer considerable advantages, he will try various modifications until he meets with success. I have not attempted to give the minute recommendations of various observers who have employed these processes; but merely indicate the general outline of the methods. A few experiments will teach the observer more than the most minute directions, and, however carefully directions may be given, it is seldom that any one succeeds the first time he endeavours to follow them out. Those who desire to do real work in this department, must be patient, and must work on steadily, until they meet with success.

OF DEMONSTRATING THE DIFFERENT STRUCTURES OF THE  
HIGHER ANIMALS.

*General Observations.*

**210. On Structure.**—The various tissues and organs of animals and plants for the most part are compound, and made up of several distinct elementary structures. For example, the smallest portion of flesh or muscular tissue, which can be removed with a knife or pair of scissars, is composed of several distinct structures. In the first place must be noticed the *proper substance* peculiar to muscular tissue, in which the characteristic contractile power resides. Secondly, at least in most cases, we find a tube composed of perfectly clear, *transparent*, almost *structureless membrane*, in which this contractile substance, or sarcous matter, is contained. Thirdly, there exists a certain quantity of *areolar* or *connective tissue*, which continuous in structure with the sarcolemma, connects together these elementary fibres; and not unfrequently associated with this is a little *fatty* or *adipose tissue*. Fourthly, are *vessels* lying between the elementary fibres just described, in which the blood circulates, for

the supply of the tissue with its proper nutritive elements. In the fifth place we find nerve-fibres running in the same position as the vessels, and lastly, at least in relation with some of the fibres, are lymphatic vessels. The student may refer to plates XXVII and XXVIII.

Thus, muscle is composed of several elementary structures, each having special anatomical peculiarities, and differing from the others in physical characters and chemical properties. Some of these structures refract light very highly; others, only in a very slight degree. One may be greatly altered or even destroyed within a very short time after the muscle has been removed from the body, or by the action of plain water, while others resist decomposition for a great length of time. The characters of one may be demonstrated when the muscle is examined in water; a second, when it is immersed in syrup or glycerine; a third, when the specimen is mounted in Canada balsam; while the arrangement of the delicate, transparent, capillary vessels cannot be satisfactorily made out unless a particular plan of preparation be adopted, as described in page 90.

The chemist can detect a number of other compounds the presence of which the microscopical observer might ever remain unconscious of, for they are dissolved in the juices of the muscle, and therefore incapable of being detected by the eye alone.

The vast difference in the properties of the several textures above enumerated renders it very difficult to demonstrate all in one single specimen, for the circumstances which favour the exhibition of one structure will often render another quite invisible. Hence, before we can hope to demonstrate satisfactorily the anatomical peculiarities of any one of these different textures we must become acquainted with its general properties, and must consider the mode of examination likely to be most efficient in rendering these distinct.

The walls of the smallest vessels are so thin and transparent that it is necessary to fill them with some coloured fluid or material more or less opaque, if we wish to see the mode of arrangement of the vascular network, while this same process, as ordinarily followed out, precludes the possibility of tracing the finer ramifications of the nerves; moreover other elementary tissues are hidden and compressed by the distended vessels. To demonstrate the nerves, all the other structures must be rendered as transparent as possible, by the application of a chemical agent, or by immersing the specimen in a highly refracting fluid. In order to show the membrane in which the contractile *sarcous tissue* is contained, the latter must be ruptured within it in a perfectly fresh specimen, or it must be separated from it by pressure. By one plan of proceeding it may be shown that the

elementary fibre of muscle may be divided longitudinally into a number of minute *fibrillæ*, arranged parallel to each other; while under other circumstances it can be separated transversely into a pile of *small disks*, or into a number of small elementary particles of definite form and size, by the connection of which to the contiguous particles, *fibrillæ* or *disks* are produced, according as the particles adhere to each other most intimately by their sides or by their ends. I might adduce many other instances of the necessity of studying the general character of tissues before any minute examination of the individual structures is attempted, but this is sufficient.

**211. On Demonstrating the Anatomical Peculiarities of Tissues.**

—Now, some observers who have not sufficiently considered the different characters of the elementary structures of which most of the organs of the body are composed, have strongly objected to what they term *methods of preparation*, asserting that by these processes, structures are even *formed* artificially which have no real existence in the natural state of the part. For this view there is some reason. Doubtless, from the examination of a dead tissue we can form but an imperfect conception of the beauty of its elementary parts, and their wonderful adaptation to the office they are designed to perform in the animal economy; neither can we form an idea of the changes taking place during life; and we must remember that there is no known fluid in which we can immerse a specimen for examination, which possesses the precise characters of that which bathes the tissue during its lifetime. Serum may, perhaps, be the nearest approach to such a fluid, but there is reason to believe that this differs from the fluid surrounding the primitive particles almost as much as some artificial media which have been proved by experience to give very satisfactory results. On the other hand it is, however, to be remarked that those who raise objections to the preparation of tissues have not satisfactorily demonstrated that by the plan they follow, many of the structures which we see after death in water, serum, and other simple fluids really have a precisely similar appearance during life, and it is more than probable that many of the more delicate tissues have never been seen by any one in the condition in which they exist during life. I believe that the amount of opacity which is absolutely necessary for seeing some of these is quite inconsistent with their natural condition, and is the result of a change which has never been fully appreciated, though, perhaps, some idea of its nature may be formed by considering the characters of fibrin in the circulating blood, and fibrin removed from the organism and coagulated, or those of albumen dissolved in the serum, coagulated but transparent in many of

the tissues, coagulated and opaque after the addition of different reagents.

It is, however, a fact that in many textures nothing is to be seen if the ordinary methods of examination are pursued, while by special processes wonderful nerve plexuses and other things most definite may be demonstrated. Some objectors will perhaps assert that the processes have formed these things!

From what has been just observed it must be evident, that the clear demonstration of the structure of any individual organ of the body is a somewhat difficult matter, and requires a considerable amount of knowledge of the chemical and physical characters of the tissues, as well as patient investigation and earnest study.

**212. General Directions for the Examination and Preservation of a Soft Tissue.**—Suppose a portion of muscular fibre is to be examined under the microscope. A small piece may be removed with a pair of very fine scissors, and placed carefully upon the glass slide. With the aid of two needles it may be torn into very small shreds, and it is then moistened with a little water dropped upon it from the finger, or from a pipette, or from the wash-bottle; or instead of water, a drop of serum, of syrup, or of glycerine may be added to it, but in this case it should be allowed to remain in the syrup or glycerine for some time, so that it may be thoroughly permeated by the more dense solution. Next a square or circular piece of thin glass held in a pair of fine forceps is gently breathed upon and applied to the surface of the liquid, being brought into contact with it, first on one side, and then allowed to fall down very gradually with the aid of a needle or piece of fine wire placed underneath one edge, until it is completely wetted, pl. XXII, fig. 142. Lastly, any superfluous fluid is to be absorbed by a cloth, or a small piece of fine sponge or blotting paper, and the slide placed in the field of the microscope for examination.

It is important to prevent the entrance of air bubbles, pl. XIX, fig. 122, during the application of the thin glass cover, and if any are visible in the tissue or surrounding fluid before it is applied, it will be better to wait a few minutes until they rise to the surface of the liquid and burst, before allowing the thin glass cover to fall in its place. While time is allowed for this to take place, the specimen should be covered with a small glass shade to prevent dust falling upon it, pl. XVI, fig. 87, p. 47.

It is advisable not to remove too much of the fluid, for fear the thin glass should press so heavily upon the preparation, as to cause the several structures of which it is composed to be squeezed together and the specimen rendered confused. The observer will find

it very useful to place a piece of hair or hog's bristle, between the thin glass and the glass slide, by which means too great pressure will effectually be prevented. The same effect is obtained by using a glass cell, but it will be found, I think, that it is more convenient to pursue the plan just described in the mere *examination* of most tissues than to place them in a glass or other cell.

The student may also refer to §§ 136, 137, 138, and 142.

Whenever a specimen is to be preserved permanently in fluid, it should be immersed in the solution in which it is intended to remain for several hours or days previous to being mounted, so that it may be thoroughly saturated with it in every part. The fluid may be placed in a moderately deep cell, in a watch-glass, or in a cup of one of the palates used by artists, from which it may afterwards be removed to the slide. The thin glass having been applied, and all superfluous fluid removed, a thin layer of Brunswick black is to be carefully placed round the edge so as to cement the thin glass to the slide. When this is dry other layers are to be applied successively until the joint is considered quite tight. The cement adheres better to the glass slide if it is roughened previously by grinding in this part, or it may be scratched with the writing diamond just where the cement is to be placed. All objects, except the very thinnest, if preserved permanently in fluid should be placed in a cell, because there is a much better prospect of their being kept permanently, than when placed upon the glass slide in the manner employed for examining the specimen temporarily. The chance of air getting into the cell is much diminished if the cement which is used possesses slight elastic power, so as to admit the alteration which necessarily takes place in the volume of the fluid under variations of temperature. For cements, *see* page 48.

### *Examination of the Simple Tissues.*

I propose now to refer very briefly to the methods of demonstrating the structure of some of the most important tissues of the higher animals, and at the same time I shall have to allude to their general characters.

**213. Areolar Tissue** can always be obtained from beneath the skin, and mucous membranes, or from the external coat of the arteries. In some situations it is lax and very abundant. It may be blown up with air, and dried to show the areolæ or spaces in which it is disposed. If the vessels be injected with plain size, the areolæ become distended with it, and when cold, very thin sections may be easily cut which show the arrangement of the fibres in the most



beautiful manner. It consists of two elementary tissues—the *white fibrous* tissue and the *yellow fibrous* or *elastic* tissue; but it is often associated with adipose tissue, and in it vessels, nerves, and frequently lymphatics ramify.

The structure of areolar or connective tissue may be well studied in pieces removed from beneath the mucous membrane of the back of the tongue or throat, or in that which connects the mucous membrane of the stomach and intestine with the muscular coat. By staining carefully, the germinal matter (nuclei) of the white fibrous tissue, of the yellow elastic tissue, of capillaries, and nerve fibres may be distinguished. It is, however, better to prepare it according to the plan given in detail in part V.

**214. White Fibrous Tissue** can be readily obtained free from the yellow element in tendons and many fasciæ. In the former, its fibres are slightly wavy, but parallel to each other. It can be split up indefinitely, and does not appear to be composed of minute fibres. This fibrous appearance is destroyed by the action of acetic acid and alkalis, and is rendered less distinct if the tissue be soaked in glycerine. Upon the addition of water, the tissue resumes its ordinary appearance. White fibrous tissue is very opaque, and in order to demonstrate its characters well, it is desirable to cut a very thin section, unravel it with needles, and subject it to moderate pressure under the thin glass. In pl. XXVI, fig. 169, a portion of tendon is represented without its nuclei.

**215. Yellow Fibrous Tissue** may be obtained, perfectly free from the white fibrous element, from the *ligamentum nuchæ*, a firm yellow cord at the back of the neck, of any animal, from arteries, or from the elastic ligament to which the retraction of the claw in the cat and other feline animals is due. It consists of circular fibres disposed to curl up very much, and not easily broken or destroyed by the action of reagents. In areolar tissue the fibres are very long and branching, after the manner of a network; in the *ligamentum nuchæ* they are parallel to each other, pl. XXVI, fig. 170: in the *longitudinal* fibrous coat of the arteries they are parallel and extremely delicate; in the *circular* coat they are coarse, and the material is often disposed in ragged laminae rather than in distinct fibres.

The germinal matter (nuclei) of both white and yellow fibrous tissue may be demonstrated according to the method of investigation described in part V. Notice also figs. 167, 168, pl. XXVI.

**216. Adipose Tissue.**—Adipose tissue may be examined by cutting off a thin section, and placing it with a little water between two pieces of glass, care being taken not to allow the thin glass cover to press upon it. The surface of one of the smallest collections of fat

cells which can be found, should be subjected to examination as an opaque object.

The mesentery, or fold of delicate membrane which attaches the intestine to the spine, of small animals, is the best place for obtaining good specimens of adipose tissue,—and being protected by the transparent covering, the relations and form of the fat vesicles are not altered. In this situation, too, the nucleus of the vesicle may often be demonstrated, and cells in every stage of growth can easily be found. Such a preparation, the vessels of which have been previously injected with Prussian blue fluid, will afford an opportunity of demonstrating all peculiarities of adipose tissue. Near the ovary of the newt and many other batrachia, there exist small collections of adipose tissue. The vesicles are much shrunken during the spring, when the ova are increasing in size, and at this time the nucleus is beautifully distinct in each vesicle. The nuclei of the cells may also be seen very distinctly, especially in starved fat cells, after treatment with a little acetic acid, pl. XXVII, fig. 172. Ordinary adipose tissue with connective tissue containing much of the yellow element is represented in pl. XXVII, fig. 174.

Frequently the more solid portion of the fat will crystallise on the surface of the more oily, in small acicular crystals, which radiate from a centre forming a star-like mass, as seen in the figures 172, 173.

Adipose tissue should be examined by low as well as by high powers (a two inch, or an inch, and a quarter of an inch object-glass), and by reflected as well as transmitted light.

**217. Cartilage.**—The characters of cartilage are very easily demonstrated. A thin section may be placed in water or glycerine. Specimens should be taken from the larynx, trachea, the ear, the ribs, the articular cartilage of joints, and the fibro-cartilage between the vertebræ, and in other situations. The ear of the mouse affords the best example of cartilage consisting almost entirely of cells. The thin layer in the upper portion of the cartilage is very favourable for studying the nutrition and mode of growth of the cells, the intercellular substance or matrix being very small in quantity in this variety of membraniform cartilage. Specimens of cartilage keep very well in dilute spirit and water, creosote fluid, and many other solutions, but on the whole glycerine is to be preferred as the medium for their preservation.

The development of cartilage, and the changes by which it is converted into bone, may be successfully studied in the flat bones of the skull of a small frog. The general changes occurring in the growth of cartilage will be understood by reference to pl. XXVII, figs. 175, 176, 177, 178. “On the formation of the so-called inter-





cellular substance of cartilage, and of its relation to the so-called cells; with observations upon the process of ossification." (Microscopical Journal, 1863.)

**218. Bone.**—Sections of bone are obtained in the manner alluded to in p. 82. It is desirable to make sections of the whole extent of the compact tissue. The observer will notice in thin sections, even of young bones, spaces of very different sizes, resulting from the division of a number of tubes (Haversian canals) in which the vessels, which are distributed to the compact tissue, run. Now it appears from the beautiful researches of Tomes and De Morgan, that this solid, hard, compact tissue is perpetually undergoing removal and repair. An Haversian canal increases in diameter by the gradual absorption of the concentric lamellæ of bone which surround it, and after a time, a large space is formed (Haversian space). When this space has reached a certain size, new bone is deposited, commencing at the circumference and gradually proceeding towards the centre, until the space has regained its small size and is again converted into a narrow canal. The *interstitial laminae* upon this view are very readily accounted for. They are, doubtless, the remains of old Haversian systems only partially absorbed. (Phil. Trans., 1853).

The growth of bone is investigated in young animals by mixing madder with their food. In a very short time (even a few days) the madder, which has an affinity for phosphate of lime, is deposited in those parts of the bone nearest to the vascular surface. Young pigs are the best animals for experiments of this kind.

The arrangement of the vessels may be investigated in the bones of an animal which has been injected with Prussian blue fluid. It is well to add an excess of hydrochloric acid to the solution. After the injection is complete, the bone may be soaked in dilute hydrochloric acid (one of acid to five of water), to dissolve out the earthy matter, when the soft tissue which remains can be readily cut into thin sections in various directions with a thin sharp knife.

Not unfrequently the vessels of bone are found distended with blood, thus producing a natural injection. It is difficult to cut and grind the section thin enough for examination without altering the masses of dried blood, but with care this may be effected. My friend Mr. White has given me some beautiful sections of the antler of the stag, in which all the vessels of the Haversian canals still retain blood.

Sections of bone may be preserved dry, in aqueous fluids, or in Canada balsam. The dark appearance of the lacunæ in sections of dried bone is entirely due to their containing air. Their apparent solidity led Purkinje, their discoverer, to call them *bone corpuscles*.

The true nature of these bodies has been already explained in page 78. Lacunæ with their masses of living or germinal matter are represented in fig. 180, pl. XXVII.

In pl. XXVII, fig. 179, a drawing is given showing cartilage and tendon continuous with it. The white fibrous tissue of the tendon is seen to be continuous with the so-called matrix or intercellular substance of the cartilage, and fig. 181, represents the changes taking place in the development of bone of a mammalian animal. These figures are worthy of very attentive study.

#### *Examination of the Higher Tissues.*

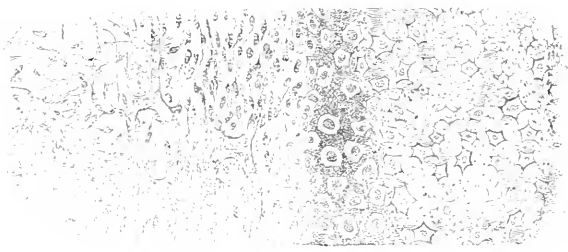
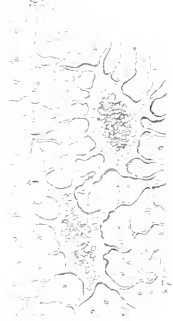
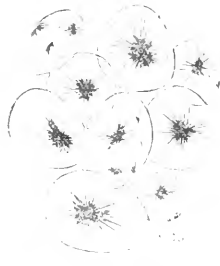
**219. Examination of Muscular Fibre.**—For a full description of the minute anatomy of muscular fibre, I must refer to the various works on physiology and minute anatomy; and especially to the well-known papers of Mr. Bowman in the *Philosophical Transactions*, 1840-41, and to the articles "Muscle," and "Muscular Motion," in the *Cyclopædia of Anatomy and Physiology*.

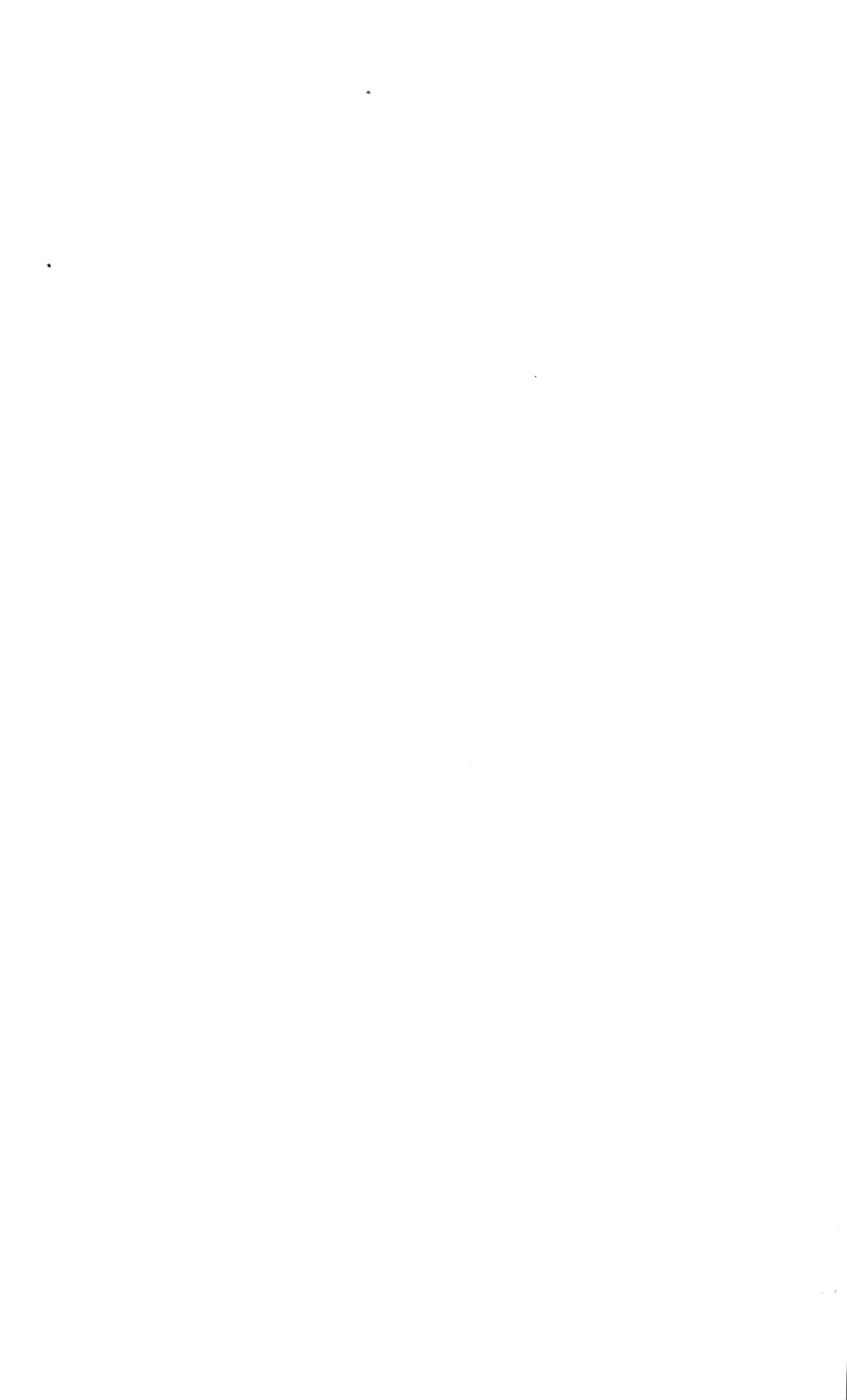
Two forms of muscular fibre have been described, the *striped* or *voluntary fibre*, or *muscular fibre of animal life*, and the *unstriped*, *involuntary*, or *muscular fibre of organic life*, the characters of which will be presently referred to. Both forms possess inherent contractility, but each contracts when touched, as may be proved by direct experiment under the microscope, or when the nerve fibres ramifying over it are touched or irritated in any other manner. The voluntary muscle alone is under the direct control of the will, while the involuntary fibre performs its functions altogether independently of volition, but both are very freely supplied with nerve fibres which ramify amongst the muscular fibres forming networks or plexuses around them.

Striped muscular fibre may be obtained from the voluntary muscles of man or any animal. If specimens be taken from the members of the different vertebrate classes, certain characteristic peculiarities will be met with, and the muscular fibre of the crustacean mollusc, or insect, differs from that of the higher animals in many important particulars.

In order to subject a portion of muscular fibre to microscopical examination, it is only necessary to remove a small piece with a sharp knife or a pair of scissors. After tearing it up with needles, and moistening it with a drop of water, the thin glass cover may be placed on it, and the specimen examined with different powers. The transverse striæ will often be rendered very distinct after the fibre has been allowed to macerate for some time in glycerine.

The general arrangement and form of the fibres in voluntary







muscles is well shown in a transverse section of the pectoral muscle of a teal (*Querquedula crecca*), which has been put upon the stretch, and allowed to become perfectly dry. A section cut as thin as possible, may be re-moistened with water, and examined in the usual manner. The position of the vessels, their relation to the fibres, and the character of capillary network are easily demonstrated in specimens which have been injected with transparent Prussian blue or carmine injection.

**220. Sarcolemma.**—The fibre of the skate, as Mr. Bowman has shown, is remarkably well adapted for showing the sarcolemma, as the sarcous matter may be ruptured while the investing membrane remains entire, and may be thus easily demonstrated. A few of the long fibres from the fin may be spread out upon a piece of glass with the aid of needles, and in this operation it will be found that the rupture of the sarcous matter in the interior has taken place. Sarcolemma is well seen in pl. XXVIII, fig. 184. This membranous tube may be also beautifully shown in the muscular fibres of a water-beetle, particularly in those of the large dytiscus.

**221. Branched Muscular Fibres.**—Several modifications of striped muscle have been described of late years, and it is desirable to consider the best methods of demonstrating a few of the most important of these. Branched muscular fibres have been found in the heart, but the finest are not very easily demonstrated. Fibres of this nature may, however, be shown to exist in great abundance in the tongue of the frog (as was pointed out by Kölliker), from which organ they may generally be obtained as follows: the tongue is to be separated from the animal, and boiled for a few moments in water; the mucous membrane is cautiously dissected off from a small portion, and a few minute pieces are to be carefully snipped off with scissors, from the edge of the tongue, just beneath the mucous membrane. These are to be torn with very delicate needles, and then examined with a quarter of an inch object-glass. In this manner very perfect fibres may generally be found; but care must be taken not to boil the tongue for too long a time, in which case the fibres become too brittle to admit of separation. These branched fibres are very beautiful objects. In good specimens they are seen to ramify after the manner of the branches of a tree, gradually becoming thinner, until each terminates in a delicate extremity, which is of a tendinous nature, and is incorporated with the sub-mucous areolar tissue or *corium*. The transverse striæ may be observed in the thinnest branches, but cease some distance from the terminal extremity of the fibre. Branched fibres also exist in the upper lip of the rat, and in other situations. Beautifully delicate branched

muscular fibres are to be seen in fungiform papillæ of the frog's tongue. *See* drawings accompanying my paper in the Phil. Trans. for 1864.

**222. Preparation of Muscular Fibre for Microscopical Examination.**—The transverse striæ may usually be demonstrated upon a piece of fresh muscular fibre, and are often seen very distinctly in a portion of ordinary voluntary muscle that has been boiled. The ultimate fibrillæ are well displayed in the muscles of many of the lower cartilaginous fishes, especially the lamprey. The mode of cleavage can be very satisfactorily determined, and the “ultimate sarcous particles” separated from each other. I have often obtained most beautiful specimens of muscular fibre from the back of the tongue, a few hours after a meal, of which meat has formed a portion. The fibrillæ often separate readily from each other in a portion of muscle which has been macerated in a solution of chromic acid.

The “fibrillæ” present different appearances according to the degree of contraction at the time of death and other circumstances. Some of them are represented in pl. XXVIII, fig. 185, after some drawings by Dr. Martyn.

Amongst vomited matters or in the contents of the stomach of an animal killed two or three hours after a meal, beautiful specimens of striped muscular fibre may often be found. In the stomach, the fibres sometimes break up into the disks described by Bowman, and I have obtained these disks by macerating the muscles of young animals for some time in strong acetic acid.

The thin, narrow, muscular bands, immediately under the skin of frogs and other small animals, will be found to exhibit well the general anatomy of voluntary muscle. The muscular fibre of the eel splits up readily into its ultimate particles; and beautiful preparations exhibiting the fibrillæ, have been obtained by Mr. Lealand from the pig. Transverse, longitudinal, or oblique sections of muscle may be made in the case of muscles which have been boiled, or hardened in spirit, bichloride of mercury, or chromic acid. The reagents of the greatest use in investigating the structure of muscular fibre, are a dilute solution of caustic soda, and acetic acid, which are employed more particularly in investigating the arrangement of the nuclei. Preparations of muscular fibre may be preserved moist in glycerine, glycerine jelly, chromic acid, or solution of creosote, pp. 56, 57, or they may be dried and mounted in Canada balsam.

The movements of muscle during contraction cannot be studied in the higher animals and man but may be observed in many of the lower animals, *see* § 256.

**223. Examination of Unstripped Muscle.**—Involuntary, smooth,



4





or non-striated muscular fibre may be obtained from various situations, both in man and also in the lower animals. These fibres are most abundant in the alimentary canal, the uterus, the bladder, the ducts of glands generally, and large vessels, but they are also found dispersed amongst fibrous tissue in certain situations, particularly in the skin. There are also bundles of pale muscle connected with the hair bulbs, which may be demonstrated in some cases. The elongated cells, of which this form of muscle is composed, are also to be demonstrated in the small arteries, pl. XXIX, fig. 189, and veins, as well as in the trabecular tissue of the spleen, and corpora cavernosa penis, the urethra, &c. Involuntary muscle, which has hitherto been described as consisting of flattened bands, has been demonstrated by Professor Kölliker to consist of the elongated cells just referred to. The contractile fibre cells usually appear as flattened bands, or fusiform fibres, slightly wavy, and terminating at each end in a point. These cells may be readily isolated by macerating small pieces of the muscular coat of the alimentary canal, &c., in dilute nitric acid, containing about twenty per cent. of strong acid. By a little teasing, with the aid of fine needles, separate cells may be readily obtained. Fig. 186, pl. XXVIII, represents some of the contractile fibre cells from the small intestine. These cells may also be demonstrated in most of the lower animals; but it is worthy of remark that a portion only of the alimentary canal of some fish is surrounded by involuntary muscle, while it has been shown that the whole of the muscular fibre of the intestine of the common tench is of the striped variety (Weber).

**224. Examination of the Muscular Structure of the Heart and Tongue.**—The muscular fibres of the heart will be found to exhibit the transverse striæ characteristic of voluntary muscle; but they are arranged in long bands, and upon carefully examining a well-prepared specimen, taken either from the heart of man or of most animals, frequent and distinct anastomoses and branchings of the fibres may be observed. The existence of sarcolemma is doubtful, but in many cases a little connective tissue which corresponds to it may often be detected.

In order to exhibit these fibres, the heart of any small animal may be taken, and after boiling it for a short time in water, small pieces may be cut off, and carefully torn up with needles. The length of time which the boiling should be continued, varies in different cases. Half a minute is sufficient for the hearts of very small animals; sheep's hearts may be boiled for a quarter of an hour. Sections of the muscular substance of the tongue are readily made by drying the organ when perfectly fresh, and removing a very thin sec-

tion with a sharp knife. The specimen is then moistened with water. It may be treated with different reagents, and afterwards preserved in glycerine, glycerine jelly, or other preservative fluid.

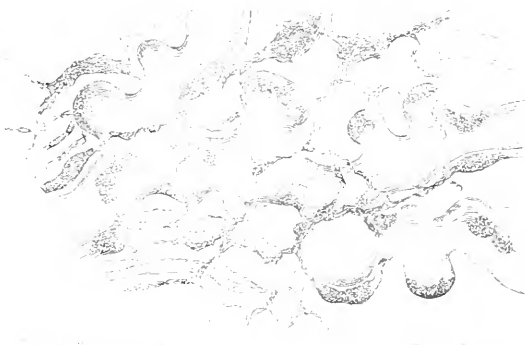
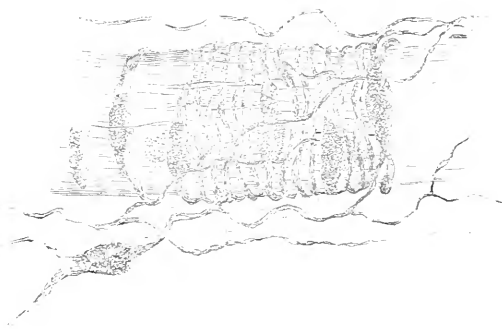
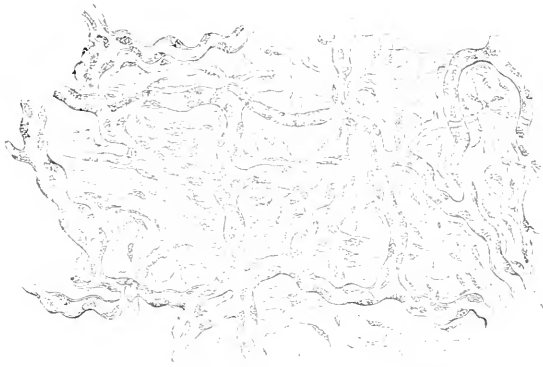
**225. Examination of Arteries and Veins.**—The structure of arteries and veins may be well studied in any of the smaller vertebrate animals, especially in the frogs. In mammalia beautiful specimens may be obtained from the mouse. Those in the mesentery, the pleura, and pericardium may be subjected to examination without difficulty, but the smaller arteries and veins of the *pia mater*, or vascular membrane of the brain, and those of the folds (choroid plexuses) of the same membrane in the cavities (ventricles) of the brain are more free from connective tissue and can be easily isolated.

The yellow elastic tissue of the arterial coats of the larger arteries may be demonstrated in any artery of a quarter of an inch in diameter or more. The fibres vary much in character, sometimes appearing rather as an expanded elastic membrane perforated here and there, than as separate fibres. In the smallest arteries and veins there is very little elastic tissue, but this is represented by muscular fibres. On the other hand in the largest vessels, the muscular fibres appear to have almost given place to yellow elastic tissue.

I have obtained beautiful specimens of the muscular fibre cells arranged circularly round the arteries by injecting the vessels with plain size, and gradually increasing the force so as to distend them as much as possible without rupture. In this manner the cells are as it were, gradually unravelled. When cold, thin sections may be very easily made in various directions, and even isolated fibre cells can be obtained. The arrangement of the muscular fibre cells in the smaller vessels, is well seen in the small arteries from the frog and newt. See pl. XXIX, fig. 189.

The arrangement of the numerous nerve fibres distributed to the small arteries and veins may be demonstrated in the frog with the greatest distinctness, and in connection with the small vessels which supply the viscera numerous ganglia will be found from which bundles of nerve fibres may be traced in different directions. These often form plexuses around the vessels and give off finer bundles, and fibres may be followed even to the capillary vessels.

**226. Examination of the Capillaries.**—Capillary vessels may be obtained from any of the tissues and organs of the lower animals. The mode of displaying their general arrangement by injection has been already described, p. 87. The masses of germinal matter in connection with their walls vary in number greatly in different parts. In some textures the capillary appears to be almost entirely surrounded with them, pl. XXIX, figs. 187, 188, also fig. 163, pl. XXV,







while in others a considerable interval of capillary wall exists which is perfectly free from them. These bodies are probably of the greatest importance and vary much in size under different circumstances. They are probably connected not only with the changes going on in the tissue around the capillary but are concerned in the separation of certain constituents from the blood. They are often seen to project into the interior of the capillary, and it seems not improbable that some of the germinal matter of the blood (white blood corpuscles) may be detached from them. Capillary vessels are supplied with nerve fibres, which may be demonstrated with great distinctness around the capillaries of the skin, tongue, and mucous membrane of the fauces of the frog or newt, pl. XXIX, fig. 192.

**227. Examination of Nerve.**—The general anatomy of the trunk of a nerve is demonstrated without difficulty. It is better to take as thin a fibre as possible, tear it up with very fine needles upon a glass slide, and after the addition of a drop of serum, it may be covered with thin glass. The small nerve trunks of any small animal may be taken. The nerves of the frog are very large, and exhibit all the essential structures of nerve fibres, pl. XXX, fig. 193. Glycerine will be found a good medium for examining nerve fibres in, but the observations should never be limited to specimens prepared according to one method of investigation only.

*a. Dark-bordered nerve fibres.*—If an ordinary spinal nerve be placed in a little water, a curious change takes place. The constituents of which the medullary sheath is composed, become altered so as to exhibit two distinct lines (white substance of Schwann), a change which probably depends upon the fatty matter being partly separated from the albuminous material with which it was incorporated, pl. XXX, fig. 195. Although this appearance is undoubtedly produced by soaking in water, the existence of a special highly refracting material within the *tubular membrane* and around the *axis cylinder*, cannot be questioned. If nerves be examined in syrup or glycerine, the double contour line is not seen.

The so-called tubular membrane can hardly be regarded as a special investment. It consists merely of delicate connective tissue in which sometimes one, sometimes several, nerve fibres are embedded, as shown in fig. 193. The outline of this apparent tubular membrane often consists of a fine nerve fibre. This is easily proved in cases where there appears to be an outline on one side only, pl. XXX, fig. 198.

The investigation of the manner in which nerves terminate is one of the most difficult inquiries that the observer can undertake. In many structures a nerve network of dark-bordered nerve fibres

may be demonstrated, but this is not terminal. The finest fibrils have often been traced for some distance and then lost. Thus some have been led to conclude that they became lost in other tissues or that they ended in the connective tissue! I have shown that in all cases they lose their dark bordered character, and are continued as a pale fibre for a long distance beyond this point, and at last form with the prolongations from other fibres a very intimate interlacement, plexus, or network, which is arranged in all cases upon the same type but differs in complexity, extent, and relations in the various terminal nerve organs. In investigating the mode of termination of nerve fibres, the papillæ of the tongue of many of the lower animals, especially of the frog may be selected.

The general distribution of the nerves beneath the skin, may be well seen in the ear of the mouse, after the thin skin covering it has been carefully dissected off. In the dura mater and other fibrous membranes, I have seen many individual nerve fibres arranged so as to form with others a coarse network, and a single fibre may often be traced for a very long distance.

The dark-bordered fibres often divide at the point where a bundle diverges from the trunk—one of the subdivisions passing on in the trunk, while another pursues a different and sometimes opposite direction in the bundle which leaves the trunk, and each of these again divides and subdivides further on. The fibres in these localities frequently leave their companions and pass a short distance with others, so that a network is in this manner formed upon the surface of the dura mater for instance and other membranes, and immediately beneath the skin. The mesentery of the mouse is a very good membranous texture in which to study the distribution of nerves in a mammalian animal. Beautiful preparations showing the distribution of sensitive nerves may be obtained from the snout of the pig, mole, and other animals. At the free edge of the third eyelid of the frog is a most extensive plexus of fine dark-bordered nerve fibres, which are arranged so as to form the most beautiful network.

The finest terminal plexuses of nerve fibres may be studied in the proper tissue of the cornea, in the fibrous tissue in the abdominal cavity of the frog, around arteries and veins, in the tongue, especially the papillæ of the hyla or green tree frog, in the mucous membrane of the pharynx, in the lung and bladder of the same animal. The relation of the nerves to the corneal corpuscles, and their prolongations should be carefully noted, pl. XXX, fig. 197. This investigation, however, presents difficulties, and the student should not attempt it until he has succeeded in making good specimens of other



Fig. 1. Stem of *Asplenium nidus* showing vascular bundles and their arrangement.



Fig. 2. Detail of a vascular bundle from the stem of *Asplenium nidus*.

Fig. 3



Section of stem of *Asplenium nidus* showing cellular details.

Fig. 4



Detail of stem section of *Asplenium nidus* showing double-walled cells.



Fig. 5. Large section of stem of *Asplenium nidus* showing the vascular network.

Fig. 6



Fig. 6. Longitudinal section of stem of *Asplenium nidus*.

Fig. 7

Detail of stem section of *Asplenium nidus*.



textures. He will find the process, detailed in part V, of great value in such enquiries.

*b. Pale Grey or Sympathetic Nerve Fibres.*—Some observers still support the assertion that every true nerve is characterised by being *dark bordered*,—exhibiting the double contour lines caused by the investment of the medullary sheath, the so-called white substance of Schwann. Remak, however, correctly described, nearly thirty years ago, the pale grey or gelatinous nerve fibres of the sympathetic system, but his views were strongly opposed by a majority, and his nerve fibres were authoritatively pronounced to be mere connective tissue. They have since been named ironically *Remak's fibres*. In Germany, for years past, many anatomists have been trying to reduce everything to what they call connective tissue, which to any ordinary observer would appear to be the least important tissue in the organism. It is even now a matter of the utmost difficulty to get a fair hearing if you attempt to extract anything real and definite out of this favoured indefinite connective tissue. In spite of all this, however, it has been clearly proved that Remak's fibres are true nerve fibres, and that dark-bordered nerve fibres before they reach their ultimate distribution, invariably assume the pale granular appearance of Remak's fibres. So far from the dark-bordered character being essential to nervous structure, the active peripheral portion, the really important part of every nerve fibre, *never exhibits it*. The white substance after all appears to be merely a passive fatty albuminous matter which surrounds the conducting core of the nerve fibre and insulates it from neighbouring fibres. It is peculiar to the trunks of nerves which connect the great central organs with the distant peripheral ramifications.

Into many sympathetic ganglionic nerve centres, however, pale fibres may be traced, and no medullary sheath exists in any part of the course of the nerve fibres. These sympathetic nerves in fact form an extended network or plexus which corresponds to the peripheral network of the cerebro-spinal nerves. The distance from their central origin to their peripheral distribution is so short that there is not that need of insulation as in the case of the fibres coming from the brain and spinal cord. Sympathetic nerve fibres and their ganglia are represented in pl. XXXI, figs. 199 to 201, and the mode of connection of the fibre with the ganglion cell is seen in fig. 202. Many observers, however, still maintain that the appearance is due to the ganglion cells being enclosed in a capsule of connective tissue, and assert that some cells exist from which no fibres whatever proceed. These strange notions are still taught in many of our most celebrated text books, and are erroneously forced upon the mind by the repetition of old figures.

It has been stated that no method of preserving nerve tissue has been devised which makes it worth while to mount preparations for the sake of displaying its minute characters, and this statement, strange to say, has been repeated in books devoted expressly to mounting objects. It need scarcely be stated here that the most delicate of the nerve textures can be mounted permanently. Not only so, but new facts in connection with their ultimate arrangement can be demonstrated in specimens which have been kept for some time, and fine fibres seen which were quite invisible when mounted. There are in truth very few objects which cannot be preserved permanently, so as to show far more than can be demonstrated in them as fresh specimens. The use of chromic and acetic acids, and perchloride of gold in the investigation of nerve structures has been referred to in p. 113.

*Examination of Serous and Mucous Membranes.*

**228. Examination of Serous and Synovial Membranes.**—Serous membranes may be examined according to the general directions previously given. It will sometimes be found difficult to demonstrate the delicate cells upon their surface, and fresh specimens only should be examined. The epithelium of serous membranes, when it exists, is of the pavement or tessellated variety, and appears to form one single layer.

A small portion of the peritoneum of a mouse or other small animal, will be found to display well the fibres of the sub-basement tissue, and often vessels and nerves may be seen beautifully distinct in this situation. The greater part of the thickness of serous membranes is made up of condensed areolar tissue, in which the yellow fibrous element is very abundant. This areolar tissue becomes less dense at a greater distance from the surface, and often contains fat cells like the subcutaneous areolar tissue.

In order to examine the distribution of the vessels in synovial membranes, an injected specimen is necessary. The fringe-like processes which project into many of the joints are highly vascular, and a well-injected specimen forms a beautiful object. The surface in the recent state is covered with large cells of a more or less globular form.

The vessels which run between synovial membrane and cartilage are very tortuous, and exhibit considerable dilatations and varicosities. The characters of serous and synovial membranes are fully described in Dr. Brinton's article "Serous and Synovial Membranes," *Cyclopædia of Anatomy and Physiology*.







**229. Examination of Mucous Membrane.**—Mucous membrane consists of one or more layers of epithelium, which rest upon a transparent texture. This surface tissue gradually passes into areolar tissue (*sub-mucous areolar tissue, sub-basement tissue* or corium). Into this structure, muscular fibres, or their tendons, when these exist, are inserted. In it ramify the vessels and nerves. The thickness of the mucous membrane and other characters of the several structures of which it is composed vary much in different localities. The mucous membrane of the mouth, especially at the back part of the tongue, may be readily subjected to examination, and the different structures enumerated may be made out. It is desirable to inject the vessels with a transparent injection, and cut thin sections through the mucous membrane and subjacent structures with a sharp knife. The basement membrane is very easily demonstrated in the tube of the kidney. On the anatomy of mucous membrane, the reader is strongly recommended to consult Mr. Bowman's article "Mucous Membrane," in the Cyclopædia of Anatomy and Physiology.

*Examination of Organs of Digestion and Absorption.*

**230. Epithelium.—Sub-mucous Areolar Tissue.**—The epithelium of mucous membranes is very readily subjected to examination, and its character is found to vary much according to the locality from which it is taken. In order to obtain a specimen of epithelium from a mucous membrane, all that is required is to scrape gently the surface of the tongue or inside of the cheek with a knife, and place what has been removed upon a glass slide, and, after moistening it with a little water, syrup, or a mixture of glycerine and water, which does not cause the cells to become so turgid from osmosis, the specimen may be placed in the microscope. This epithelium approximates in its characters to that of which the epidermis or cuticle is composed. The cells obtained are almost all of them mature and some are very old, invaded by fungi and about to be cast off, pl. XXXII, fig. 203. The thin glass cover should not be allowed to press too strongly upon the specimen. This may be prevented by inserting one or two pieces of hair or thin hog's bristles. The epithelium upon the surface of the tongue of the frog, toad, newt, and that lining the mouth of the serpent and some other reptiles is ciliated. See fig. 236, pl. XXXVII, also p. 161.

In many of the glands which may be regarded as cavities opening upon the surface of the mucous membrane and continuous with

it, the cells are modified in structure and arrangement. They produce peculiar substances, which constitute the *secretion* of the gland.

*Glandular epithelium* may be obtained from the tubes or glands in the mucous membrane of the stomach, from the liver, kidney, and other organs.

*The mucous membrane of the stomach* should be studied in *vertical* sections, and in sections made at different depths *parallel with the surface*. The pig's stomach is a good one for examination. A very sharp knife is required. The thinnest sections may be obtained after drying the mucous membrane according to the plan described in page 82. The sections are to be remoistened with distilled water, and made transparent by the addition of a little weak acetic acid or potash.

The sub-mucous areolar tissue may be very readily demonstrated by removing a small piece from the under surface of the mucous membrane with scissars, and tearing it up with needles. Beneath the hard cuticular mucous membrane of the œsophagus, there is an abundant layer of lax areolar tissue, which connects the lining membrane with the muscular coat beneath, and permits the greatest alteration of the form of the tube during the passage of its contents, to take place. A small piece of this may be readily removed for examination and consists of areolar tissue with vessels, nerves and a few lymphatics.

**231. Villi.—Muscular Fibres.—Lacteals.**—One of the best plans of demonstrating the villi, which project from the surface of the mucous membrane of the small intestine is the following:—A stream of water is allowed to flow over the surface so as to cause the villi to fall in one direction. A clean cut is then made across the intestine, and the villi caused to fall in an opposite direction by the stream of water. When a very thin section is removed from the freshly cut surface, one or two rows of entire villi will be readily obtained.

The epithelium is often removed from the surface of the villi by this process. Its arrangement is represented in pl. XXXII, figs. 207, 210, and in fig. 204 some of the separate cells are seen.

*The muscular fibres* are to be shown by washing off the epithelium, and treating the villi with a solution of acetic and nitric acid, composed of about four parts of water to one of acid. Besides the longitudinal muscular fibres first described by Brücke, there are circular or transverse fibres, which I have demonstrated by the aid of the process described in part V. Nerves and ganglia of the intestine are referred to in p. 129. *See also* pl. XXXI.

The elementary structure of the muscular coat of the intestine may be demonstrated by soaking small shreds in nitric acid diluted with four or five parts of water.

The *Lacteals* may be demonstrated when filled with chyle at the time of death. Their arrangement may be very satisfactorily observed in the villi of a rat or mouse which has been fed upon a small quantity of fatty food for some time before death. The animal should be killed by suddenly dashing it on the floor. It should be examined immediately or the lacteals will become emptied before they are placed under the microscope.

The alimentary canal of the mouse is well suited to the purpose of microscopical investigation. The villi are large and conical, and beautiful transparent injected preparations of them may be made. A small piece of intestine may be injected without difficulty according to the plan indicated in fig. 166, pl. XXV. After the vessels have been injected, the intestine is to be slit up and small pieces inverted upon the surface of glycerine containing a little acetic acid (1 per cent.). In this way the villi are made to stand up firmly from the surface of the mucous membrane, and they retain their position when the specimen is mounted permanently, pl. XXXII, fig. 208. In fig. 209 villi in which the lacteals have been injected are represented.

**232. Of the Movements of the Chyle.**—For studying the *movements of the chyle* in the lacteals, a mouse, rat, or young rabbit may be taken. The animal should be fed with a little lard beaten up with a piece of pancreas and a small quantity of bile, so as to form a soft pultaceous mass which may be strained through muslin. About half an ounce, or less, of the cream-like fluid may then be injected by the aid of a small syringe into a flexible catheter which has been passed down the gullet into the animal's stomach. After a couple of hours, the creature should be pithed, stunned, or destroyed very suddenly, and a small portion of the mesentery with the intestine attached withdrawn through an aperture in the abdominal walls and submitted to microscopical examination with a low power.

#### *Organs of Circulation.*

The examination of the various textures entering into the formation of the circulating organs has been already referred to, but I propose in this place to describe the method of examining the blood corpuscles, and allude to that of investigating the phenomena of the circulation during life.

**233. Blood Corpuscles** or globules from the human subject, are represented in pl. XXXIII, fig. 212. Their general characters, and especially their colour and refractive power, should be contrasted with oil globules of different kinds, air bubbles, and microscopic

fungi. The student should carefully examine specimens of these bodies. Blood corpuscles are readily obtained by pricking the finger. A very thin stratum of the fluid is alone required. By drawing a needle across the thin glass under which the blood corpuscles are placed, they may be divided into many smaller globules. This proves that the red blood corpuscles consist of a mass of soft viscid matter, the outer part of which is somewhat hardened. This subject has been fully considered in "The Microscope in its Application to Practical Medicine," p. 169. The sporules of some fungi very closely resemble blood corpuscles, and have been mistaken for them. The common yeast fungus, in different stages of growth, is represented in pl. XXXIII, fig. 211. The blood corpuscles of some animals crystallize very readily. The student should place a drop of Guinea pig's blood, under thin glass, and study the changes which occur in the corpuscles during a quarter of an hour or twenty minutes, pl. XXXIII, figs. 213, 216.

The sloth and the camel, among mammalia, are said to possess nucleated red blood corpuscles, but Dr. Rolleston was unable to verify this observation in an examination he made a short time since. We cannot, however, entirely accept his conclusions, because the blood examined by him was dried on the glass slide. "Note on the Blood Corpuscles of the two-toed Sloth, *Cholœpus Didactylus*," *Mic. Journal*, April, 1867, p. 127.

Red blood corpuscles of the frog are represented in fig. 214, pl. XXXIII, and in fig. 215, white blood corpuscles of the same animal.

**234. Of the Circulation of the Blood.**—For studying the circulation in the web of the frog's foot, a young frog with a thin web should be selected. The body and one hind leg are loosely bound up in wet rags, the other leg being allowed to protrude. The body is then tied to the frog plate, and a piece of thread having been carefully tied to two of the toes, the webs may be stretched over the glass at the end of the plate, and fixed in the proper position for observation. A drop of water may then be added, and the web covered with thin glass.

By careful observation of the circulation, first of all under a low power, and then under a quarter of an inch object-glass most important and highly interesting facts will be learnt. In cases in which it is necessary to conduct observations on the circulation with the aid of very high powers, it will be found desirable in practice to increase the length of the tube instead of employing object glasses of very high magnifying power. A quarter of an inch object glass may thus be made to magnify as highly as a twelfth, and as the distance

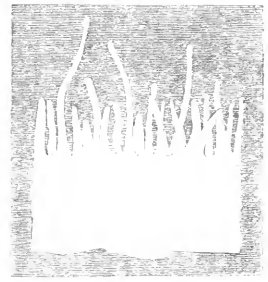
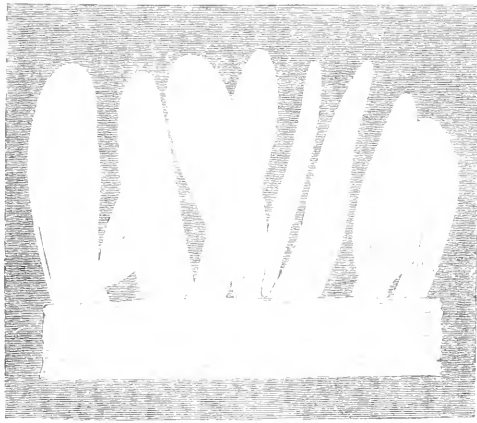
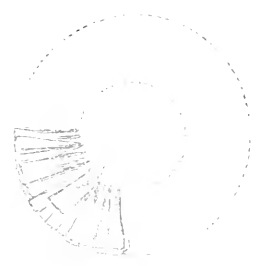


Fig. 1





between the object glass and the thin glass covering the web is very considerable, there is not the same danger of serious derangement every time the animal moves slightly. Several different lengths of tube may be adapted to the microscope body, which may be thus increased to the length of two feet or more, if desired.

If a small artery be brought into focus and the tip of one of the toes be very lightly touched, the artery is seen to contract immediately, and somewhat irregularly in different parts of its course. Sometimes a few blood corpuscles are firmly compressed, and for several seconds the vessel remains so strongly contracted that not a corpuscle passes along it. By performing this instructive experiment, the observer may realise the effects of the wonderful contractile power of the coats of the smaller arteries, and demonstrate conclusively that the afferent nerve fibres distributed to the skin of the foot generally, influence the nerve centres from which the nerves ramifying amongst the muscular fibres of the arterial coats take their use. This is a beautiful instance of reflex nervous action affecting the vessels.

The circulation may also be studied during life in the capillaries of the tail of a small fish, minnow, stickleback, eel, carp, &c. The fish should be wrapped up in wet lint and loosely tied at one end of a glass slide, the tail being placed about the centre, and covered with a piece of very thin glass.

**235. Of the Action of the Heart.**—A more correct idea of the mode of action of the heart may be formed by watching its contractions in a small living animal under the microscope than in any other way with which I am acquainted. A young fish, or newt, or frog tadpole may be taken for the purpose, but I have found that a young snake removed from the egg exhibits the phenomena most beautifully. The blood may be distinctly seen as it eddies through the various apertures in passing to or from the different vessels and cavities of the heart. The undulating contractions of the auricles and ventricle of the heart are very wonderful. Under a two-inch power adapted to a binocular microscope, the movements of the heart may be studied most advantageously.

The circulation in the tadpole has been well described by Mr. Whitney (Trans. Mic. Soc., vol. X, p. 1, 1862.) The animal should be starved for a few days before being submitted to examination, in order that the intestine may become transparent.

The *branchiæ* of the frog tadpole or young newt may be examined in a flat glass cell specially prepared for the purpose, and by an arrangement of tubes the animal may be supplied with fresh water while it remains under observation. In pl. XVIII, fig. 106, is represented a form of cell which I made some years ago for a proteus, but

a cell for a newt or other animal may be made upon the same plan. The circulation of the blood in the capillary vessels of a mammalian animal may be studied in the thin membrane forming the wing of a young bat.

The examination of the moving objects alluded to in this section, should be conducted with the aid of the binocular.

### *Examination of Organs of Respiration.*

**236. Lung.**—There is not much difficulty in demonstrating the different tissues of which the lung is composed. Small pieces may be cut off, and spread out upon the glass slide in the usual way; the preparation being moistened with water or serum. The addition of a little acetic acid causes the yellow elastic tissue to become very distinct. The boundaries and arrangement of the air-cells may also be readily shown.

No opinion with reference to the nature of the walls of the air-cells can be arrived at, unless injected as well as uninjected specimens are examined. The twisted and shrunken capillaries of the recent lung containing a few blood corpuscles, produce an appearance which is very likely to give rise to erroneous inferences with regard to the disposition and coverings of these vessels. Either the Prussian blue or carmine injecting fluid may be employed. A most instructive preparation of the lung, however, is made by injecting the vessels with tolerably thick transparent gelatine, which transudes through their walls, and fills the air-cells. After the lung has been thoroughly injected, it is set aside to get cool. Thin slices may be examined, and the vessels will be seen *in situ* apparently bare, and uncovered by epithelium. (Physiological Anatomy, Todd and Bowman, page 393. Mr. Rainey in the Medico-Chirurgical Transactions, vol. XXXII. 1849, page 47.)

Much difference of opinion has been expressed with reference to the existence of epithelium in the air-cells of the lung. I have lately carefully examined healthy human lungs which have been prepared in various ways, and have completely failed to demonstrate the presence of such a structure in the healthy adult, or in the lungs of several mammalian animals. I have never seen such appearances as are represented in many drawings, showing this epithelium so distinctly, that one would be led to conclude that it was to be seen without the slightest difficulty. In the fœtus and young child however, cells are found in the air-cells, but it seems to me very doubtful if these take any part in the function of respiration. The masses of germinal matter (nuclei) of the capillary walls may be very easily





Fig. 1. - ... ..  
.....  
.....



Fig. 2. - ... ..  
.....  
.....

Fig. 7.

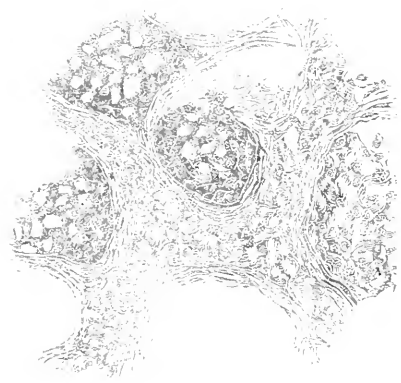


Fig. 11.

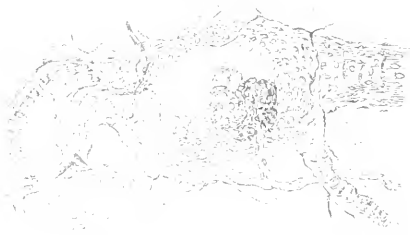


Fig. 12. - ... ..  
.....  
.....



mistaken for epithelium, fig. 217, pl. XXXIII. In the lungs of the frog and newt there are, however, distinct epithelial cells.

*Trachea and Bronchial Tubes.*—The *mucous membrane* of the trachea and bronchial tubes must be examined in the recent state by cutting thin sections with a very sharp knife.

Beneath this mucous membrane is an abundant plexus of lymphatic vessels. In many cases these contain lymph corpuscles and fatty matter in a granular state, so that their arrangement may be easily made out. The lymphatics upon the surface of the lung, immediately beneath the pleura, may also sometimes be very clearly demonstrated. I have one specimen in which these lymphatics are completely distended with large oil globules and granular matter, so that the position of their valves is rendered very distinct, and the smallest branches can be followed into the intervals between the lobules of the lung. In this specimen the tubes certainly form a network, but in many situations appearances are observed which lead to the conclusion that these tubes also commence in cæcal extremities.

In examining the ciliated epithelium of the air passages, it is only necessary to scrape the surface gently, and, if necessary, the preparation may be moistened with a little serum, as water would very soon stop the motion.

#### *Organs of Secretion.*

**237. Salivary Glands and Pancreas.**—The investigation of the salivary glands and pancreas scarcely requires any special remarks. The best idea of their structure is obtained by subjecting one of the smallest labial or buccal glands, and Brunner's glands to examination. The ultimate follicles and epithelium are very easily demonstrated in specimens which have been soaked for some time in glycerine. It is often troublesome to trace the continuity of the duct with the follicles, in consequence of some of the latter covering its terminal portion. The ducts of the salivary gland and pancreas may sometimes be injected, and it is advantageous to subject the organs to firm pressure for some time previously, so as to absorb as much as possible of the fluid they contain, and favour the entrance of the injection. Good sections may often be obtained from specimens which have been hardened in alcohol and soda. The arrangement of the capillaries is easily made out in specimens injected with vermilion, chromate of lead, or transparent injection. If the vessels are injected with gelatine only, very instructive sections may be made. In such investigations, however, it is necessary to make a vast number of sections and

examine them carefully, or the observer will not be able to form a correct idea of the structure of the gland.

**238. Liver—General Examination.**—To demonstrate the different structures in the liver very different processes are required. If the cells alone are to be examined, a freshly-cut surface may be scraped with a sharp knife, and the matter thus removed placed in a drop of water or serum, and covered with the thin glass. The appearance of a cell wall is pretty distinct in water, but this is due partly to the difference in refractive power of the water and the material of which the so-called cell is composed, and partly to the action of the water itself upon this. If the cells be placed in serum or glycerine, they appear perfectly solid, and no envelope can be discovered, and in some cases sharp points are seen to project from different parts of the cell, a fact which renders the presence of a membrane almost impossible. The liver cell is in fact a mass of soft material the outermost part of which is undergoing change.

In order to demonstrate the relation which the different elements and structures of the liver bear to each other, it is advisable to cut a very thin section by means of Valentin's knife, from the organ when quite fresh; or thin sections may be taken from portions of liver which have been hardened in alcohol, chromic acid, &c. The vessels of the liver may sometimes be demonstrated by washing the cells away from a thin section with a stream of water, and then treating it with a little dilute caustic soda. In specimens prepared in this way, however, the capillaries are often quite invisible. From the extreme tenuity of their walls in many cases, not a trace of them can be discovered—indeed the existence of the capillary wall can only be proved by filling the vessels with transparent injection in the first instance.

A consideration of the various elementary tissues of which the different organs of the body are composed, would of itself almost lead to the inference that several different methods must be employed when we desire to demonstrate their individual characters. The medium in which these different tissues are most satisfactorily examined, depends upon certain physical characters, chemical composition, transparency and refractive power. It is, therefore, next to impossible to demonstrate all the anatomical elements of which an organ is composed in one single specimen. The student should bear in mind that the idea of the organ as it exists during life, is formed from building up, as it were, in his own mind the various structures, the arrangement of which has been demonstrated by several distinct methods of investigation.

**239. On Demonstrating the Structure of the Liver.**—The inves-

tigation of the structure of the liver is somewhat difficult, owing to the numerous distinct tissues which compose the organ and their intimate connection with each other.

*Lobules of the Liver.*—The arrangement of the lobules in most livers is very different to that of the pig. In the latter there are distinct lobules, each being inclosed in a capsule of fibrous tissue. In that of most animals, however, although there is a mapping out of the entire organ into small elementary organs, or lobules, these are not separated from each other as in the pig, but the capillaries of one lobule communicate at various points with those of adjacent lobules. They are not separated by fibrous or other tissue, and no structure answering to the description given of Glisson's capsule, can be demonstrated in this situation. Great confusion with regard to the nature of the "lobule," has arisen from observers considering the pig's liver as the type to which others should be referred, whereas its arrangement is exceptional and totally different from the human and most mammalian livers.

Separate pieces of liver the size of half an orange may be injected without difficulty. In one the portal vein may be filled; in another the hepatic vein; in a third the artery, and in a fourth the duct, or two or more of these tubes may be injected in the same specimen. The portal vein, the artery, and the duct run together, while the branches of the hepatic vein run by themselves, so that in sections where the vessels are large, the student will soon have to distinguish the different tubes.

*Portal Vein.*—The general arrangement of the portal vein may be easily demonstrated by injecting one of the large trunks of this vessel. Any of the ordinary injecting materials may be used, but I prefer the Prussian blue injection to which sufficient gelatine has been added to cause it to set firmly. It is desirable not to attempt to make a very complete injection, but to leave the capillaries, in the centre of the lobules, in an uninjected state.

*Hepatic Vein.*—The injecting pipe may be placed in one of the branches exposed on the cut surface of the liver. The injection runs very readily, and upon examination it will be found that the capillaries in the centre of the lobules only are filled. The portal vein may be injected in one part of a liver, and the hepatic vein in another part. Sections of the lobules in which the latter has been injected, of course form the exact complement of those of the former. In the one, the central portion of the lobule has been injected, while in the other, the injection is confined to the vessels and capillaries at the circumference of the lobule. By injecting the portal and hepatic veins in the same part with different colours, these

points may be shown in one preparation. Beautiful specimens of this kind may be prepared by injecting one vessel with the acid carmine and the other with Prussian blue fluid. See pages 95, 97.

Thin sections may be cut with Valentin's knife or with the double-edged scalpel; and it is desirable to take several thin sections from the surface of the organ. The sections may be preserved in fluid or dried and mounted in Canada balsam; I much prefer glycerine as the preservative medium.

*Artery.*—The surface of the organ is supplied by an extensive arterial network, and the portal canals also contain a similar network. The coats of the ducts are largely supplied with arterial blood, and the finer ducts are in close relation with numerous small branches of the artery. The precise mode in which the blood is poured into the veins has been a subject of great dispute, but I have many preparations which show that the blood is poured into the portal capillaries near the circumference of the lobule as Kiernan long ago inferred, and not into those near the centre, *Phil. Trans.*, 1833.

**240. Of Injecting the Ducts of the Liver.**—The method of injecting the ducts of the liver has been already described in page 101.

Since the publication of my paper in the *Phil. Trans.* for 1855, and memoir upon the anatomy of the liver, in which this mode of investigation was described, 1856, several views concerning the arrangement of the ducts absolutely incompatible with my own have been advanced by continental anatomists. The plans which I followed have been repeated several times, and have in every instance confirmed the results which I previously arrived at. I have quite recently (1867) re-studied this subject and have succeeded in making some preparations which are quite conclusive as to the continuity of the ducts with a cell containing network in the lobule.\*

**241. Kidney. The Anatomy of Glandular Organs more easily**

\* It is curious to observe how positively some reiterate the assertion that the mammalian liver does not possess a tubular structure—Quite recently Ewald Hering, of Vienna, after admitting that the vertebrate liver in general is to be regarded as a “reticularly arranged tubular gland,” goes on to say that “all the oft-repeated accounts of a tubular structure of the mammalian liver, I must point out as erroneous (!). For instance, Beale's familiar representation, which is intended to demonstrate the tubular structure of the pig's liver, shows me plainly that a completely ruined (!) preparation was the foundation of it. The injection mass is extravasated out of the gall ducts, the liver cells are distorted from their natural position, and to such an extent destroyed. Beale has also investigated the liver of cold-blooded vertebrata, and this may have misled the distinguished microscopist in supposing (!) analogous circumstances for the mammalia.” I can assure this observer that my specimen was not ruined, that I saw what I affirmed, and have never advanced as demonstrations what are but suppositions. Further observations I venture to think will convince Hering that the mistakes and suppositions are not on my side.

**Demonstrated in the Lower Animals than in Man and the Higher Animals.**—In consequence of the great complexity of the structure of many of the tissues of the higher animals, their rapid change after their removal from the body, and their extreme delicacy, anatomists have long been in the habit of resorting to the examination of textures in the lower forms of animal life for obtaining an insight into the structure of parallel tissues in the higher, and with considerable success. I can adduce no better example of the great value of such an appeal to the simpler forms of animal life than occurs in the case of the *kidney*.

In animals generally, this gland consists essentially of a vast number of long and highly tortuous tubes—which in the higher members of the class are packed so closely together that they form a firm and very compact organ, the general characters of which are familiar to all—and of vessels bearing a particular relation to these tubes. In such a kidney it is impossible, under ordinary circumstances, to follow a tube for any very great length, as the observer will be convinced if he looks at a specimen in the microscope; but in the lower animals the kidney is less compact, and the several tubes are not so intimately connected together. Indeed, in many of them the kidney is prolonged into a thin, transparent, almost thread-like organ, which extends into the thoracic portion of the animal. In this situation in the common *newt* or *eft* (Triton or Lissotriton) we have, so to say, a natural dissection of the elements of the gland structure, and we may *demonstrate* an arrangement, the existence of which we can only *infer* by an examination of thin sections of the compact kidney of mammalia. The method of dissection is described in § 257 on Ciliary Movement, p. 162. Single tubes, with the structures connected with them, may be traced throughout their entire length, and are quite separate from one another. I need hardly observe, that it would be vain to attempt to make such a dissection artificially. See fig. 218, pl. XXXIII. A probe is placed under this portion of the kidney. If a piece of this be carefully removed from the recently-killed animal, the cilia lining the whole length of the tube will be seen in active vibration. Beautiful specimens, showing the continuity of the tube with the flask-like dilatation enclosing the vessels of the tuft, may be obtained from animals which have been injected with the Prussian blue fluid, fig. 219.

Many other instances of the value of this kind of investigation might be adduced of equal interest and importance, but instead of occupying time in this manner I will most strongly urge upon all those who are likely to prosecute researches upon the characters of any particular tissue or organ, the importance of investigating care-

fully its nature in the different members of the creation, and especially in the lowest forms in which its existence has been proved,—for there we may be sure to find it in its simplest condition, and the mind will be better able to appreciate the exact meaning of the structures which are superadded, and the more elaborate anatomical detail which is met with in the higher animals, than if we commenced our researches upon the most perfect examples of the structure.

In the examination of the mammalian kidney, the epithelium and fragments of the tubes may be readily obtained by scraping the freshly cut surface. In this manner also Malpighian tufts may often be separated, but it is impossible to ascertain the relation of the different structures to each other, as by the process of scraping they are inevitably very much torn. A thin section in which these points may be demonstrated, is obtained either with a sharp thin-bladed knife, or more advantageously with a Valentin's knife, by which means a section including both the cortical and medullary portion of the organ may be made. After washing the section very slightly, it may be placed with a drop of water between two pieces of glass, and examined in the microscope, first using a low power (an inch glass), by which the general arrangement of the tubes will be seen, and afterwards a quarter of an inch object-glass, by the aid of which the different characters of the epithelium in the straight and convoluted portions of the tubes may be demonstrated.

**242. Basement Membrane, Matrix, and Vessels.**—Just at the edge of the specimen, a portion of a tube stripped of epithelium, and exhibiting the basement membrane very distinctly, may often be observed.

The appearance which has been described as resulting from the presence of a matrix may be seen very clearly in a section of the kidney of a mouse, or in that of many other rodents. It must, however, not be forgotten how very difficult it is to say how much of the appearance is due to the presence of the walls of the tubes and capillary vessels, and how much to the existence of a structure (the so-called matrix) independent of, and occupying the intervals between, these. Where the capillaries are injected with transparent injection, no fibrous appearance is to be detected; and I believe, at least in healthy kidneys, that the material resembling fibrous tissue, really consists of the walls of the tubes and the shrunken and otherwise altered capillaries.

Here and there, apparently upon the vessels of the Malpighian tuft, a few cell-like bodies are often seen. These have been described by some as epithelial cells upon the external surface of the vessel, but the researches of Mr. Bowman proved that the vessels are quite



bare. The appearance of epithelium upon the surface of the vessel, is caused by the loops of capillaries being shrunken and collapsed. When distended with transparent injection, no such appearance is observable, but here and there a few very small granular cells are observed. Masses of germinal matter or nuclei, are connected with the walls of these vessels, as well as those in other tissues. See p. 126.

### *Organs of Innervation.*

**243. Examination of the Brain.**—The brain may be subjected to examination as soon as possible after death. In examining the fresh brain, small portions may be removed on the end of a knife, placed upon the glass slide, and moistened with a little serum, or weak solution of sugar, but it must be admitted little can be learnt by such a mode of examination, as the relation of the structures to each other is completely destroyed. For examining the arrangement and distribution of the nerve fibres, portions of brain should be hardened in the chromic acid solution, p. 57, when very thin sections can be obtained with a sharp razor. Dilute solution of caustic soda is also exceedingly useful for rendering the nerve tubes more distinct. The minute anatomy of the brain may be studied in man and in the higher animals.

The examination of the dura mater and arachnoid is conducted according to the general plan already laid down. Very small pieces are removed, carefully torn up with needles, moistened with water, and covered with thin glass. The gritty substances (brain sand) in the pineal body, and those which are not unfrequently met with in other parts of the brain, and the *Hassall's corpuscles*, or *corpora amyloacea*, may be separated from the brain substance by washing in a glass of water, in which they will sink to the bottom; the supernatant fluid may then be poured off, and replaced by fresh water. After this process has been repeated a few times, the bodies in question will become quite clean. They may then be examined in water, tested with appropriate reagents, and preserved in aqueous fluid, or dried and mounted in Canada balsam.

The vessels of the brain may be readily examined if the white or grey cerebral matter be first removed by washing a thin section with water. The addition of a little very dilute caustic soda renders the outline more distinct.

The investigation of the anatomy of the central organs of the nervous system is perhaps the most difficult which the student can undertake, and it is not easy to lay down principles for his guidance. Very much yet remains to be discovered with reference to the

chemical solutions adapted to render the anatomical elements of these tissues distinct. There can be no doubt that modes of investigation will at length be found out which will enable us to demonstrate satisfactorily the relation of the delicate structures which make up the nervous system, to each other. The student should try for himself a number of fluids of different composition. I cannot too strongly recommend the plan invented by Mr. Lockhart Clarke, which is given below, for carrying out enquiries of this nature.

If a portion of white cerebral matter be treated with water, the nerve fibres soon become changed in character, apparently in consequence of the partial separation of the oily from the albuminous constituents which are contained within the tubular sheath. The oily matter forms distinct and separate globules, often of considerable size, or it tends to collect in quantity in different parts of the fibre, which produces a beaded appearance. A similar change takes place in nerve fibres generally, if they are not examined very recently, or if they have been soaked for a short time in water. In fig. 196, pl. XXX, some of these changes are represented.

**244. Examination of the Spinal Cord.**—Different parts of the cord may be examined in the fresh state, but in order to demonstrate the beautiful structure described and figured in modern works, we must have recourse to certain methods of preparation. A weak solution of chromic acid is invaluable for investigating the structure of the cord. Segments of different parts are placed in the solution and allowed to harden, when very thin sections may be readily obtained and examined.

The method of preparation followed by Mr. J. Lockhart Clarke, in his beautiful and highly important investigations on the structure of the spinal cord was the following:—

A perfectly fresh cord was hardened in spirits of wine, so that extremely thin sections, in various directions, could be made by means of a very sharp knife. A section so made was placed on a glass slide, and treated with a mixture composed of one part of acetic acid and three of spirits of wine, which not only makes the nerves and fibrous portion more distinct and conspicuous, but renders also the grey substance much more transparent. The section was then covered with thin glass, and viewed first by reflected light with low magnifying powers, and then by transmitted light with higher ones.

According to the second method, the section is first macerated for an hour or two in the mixture of acetic acid and spirit. It is then removed into pure spirit, and allowed to remain there for about the same space of time. From the spirit it is transferred to oil of turpentine,



Fig. 1. a, b, c





which expels the spirit in the form of opaque globules, and shortly (sometimes immediately) renders the section perfectly transparent. The preparation is then put up in Canada balsam, and covered with thin glass. By this means the nerve fibrils and vesicles become so beautifully distinct, that they may be clearly seen with the highest powers of the microscope. If the section be removed from the turpentine when it is only semi-transparent, we sometimes obtain a good view of the arrangement of the blood-vessels. This mode of preparation succeeds best in cold weather, for in summer, the cord, however fresh when immersed in the spirit, remains more or less spongy, instead of becoming firm and dense in the course of five or six days. The spirit should be diluted with an equal quantity of water during the first day, after which it should be used pure. Certain modifications of this mode of preparation may be sometimes employed with advantage by a practised hand. (Phil. Trans., 1851). These processes are more or less applicable to the investigation of the brain and some ganglia.

For some time past Mr. Clarke has adopted a modification of his original plan. He has been kind enough to send me the following directions.

The spinal cord and medulla oblongata of man, and the higher mammalia are to be cut into pieces of half or three quarters of an inch long, and steeped in a solution of one part of chromic acid in 200 parts of water, for three weeks or a month. It is then preserved for use in a solution of about one part of *bichromate of potash* in 200 parts of water. For hardening the convolutions of the cerebrum and cerebellum, the solution of chromic acid must be weaker than for the spinal cord or medulla oblongata, that is the proportion of one part of the acid to four, or even five hundred parts of water; but the portions of brain must be small, not more than half an inch thick, otherwise they become rotten before the acid has reached their centres. A little spirit added to the solution for two or three days, after the first day, will prevent this. The pure solution can then be renewed.

Spirit of wine is used to wet the knife or razor in making sections, which should be washed in water before they are placed in solution of carmine. When sufficiently coloured, the sections are again washed in water, and placed for ten minutes or a quarter of an hour in strong spirit; after which, if they be thin, they are floated on the surface of spirit of turpentine, where they remain until they are quite, or nearly, transparent, when they are removed to glass slides, on which a little Canada balsam has been previously dropped. If now examined under the microscope, they frequently show but little traces of either cells or fibres—a circumstance which seems to have

caused Schroeder, Van der Kolk, and some others, to abandon the method *at first*,—but if the sections be set aside for a little while, and treated occasionally with a little turpentine, the cells and fibres reappear, and present a beautiful appearance. Before they are finally covered with thin glass, they should be examined at intervals under the microscope, to see whether all the details of structure have come out *clearly*; and if so, as much Canada balsam must be used as suffices for mounting. If the sections be of considerable *thickness*, it will be found best to place them in a shallow vessel, the bottom of which is kept simply wet with turpentine, which can therefore ascend through them from below, while the spirit evaporates from their *upper* surfaces, for the *principle* of the method is this:—to replace the spirit by turpentine, and this by Canada balsam, *without drying* the sections. The method at first is attended with some difficulty, and practice is necessary to ensure complete success. Experience, also, may suggest, according to circumstances, certain modifications of the *exact* process here given, which, to a certain extent, must be considered as general.

This method is now generally adopted in investigating the structure of the brain and spinal cord. Longitudinal and transverse sections of the spinal cord are represented in pl. XXXIV, figs. 220, 221.

**245. Examination of Nerve Ganglia.**—The sympathetic ganglia and the ganglia on the posterior roots of the nerves should be obtained from young animals, for in adults and in those advanced in age, the quantity of connective tissue is so great as to hide many of the cells and render it impossible to trace for any great distance the very pale delicate nerve-fibres connected with them. In investigations upon the structure of these cells I have pursued the plan of investigation described in part V, by the aid of which I was enabled to demonstrate that at least two fibres (one of which in the frog's ganglion cells was coiled round the other) came from every one of these ganglion cells, and that the fibres when they reached the nerve trunks pursued opposite directions. *See* pl. XXXIV, fig. 223.

#### OF COLLECTING, KEEPING ALIVE, AND EXAMINING THE LOWER ANIMALS.

**246. Of Collecting and Dredging.**—To those fond of natural history, few things are more delightful than a ramble over the beach at low water for the purpose of collecting. Sea dredging adds not a little to the charms of boating, and by the aid of the dredge many interesting creatures may be caught, which never advance to low water mark. But there are many organisms which inhabit shallow fresh water pools of great interest to the observer. The apparatus

required for taking these is very simple, and I shall refer to it before describing that for marine or shore trapping. The following appliances have been arranged by Mr. Highley, whose great practical experience is well known, and nothing can be more suitable for the purpose or more ingeniously designed. I therefore recommend the observer to provide himself with the following simple pieces of apparatus.

*A walking stick* with a telescopic joint, pl. XXXV, fig. 224, so that its length may be doubled when required, for the purpose of reaching far out into ponds or deep down between rocks, ditches, or river banks. To the end of this, may be screwed a *wide-mouthed bottle*, which is introduced into the water mouth downwards, after the manner of a diving-bell, and only turned upwards when near the desired object, and in such a way that it may be carried into the bottle with the rush of water. The bottle should then be carefully brought to the surface. Such objects as are desired should be selected and removed by aid of a *pocket pipette*, fig. 224, and transferred to the tubes hereafter described. This pipette consists of a glass tube drawn out to a point and cemented into a German silver tube, which is fitted with a cap, after the manner of a pen case, so as to protect the glass, which may be carried in the waistcoat pocket. Larger objects, such as water insects, young newts, &c., should be caught by means of a small *folding net*, which also screws into the stick. Tough weeds required for study, or which are covered with animal or vegetable parasites, should be cut away by means of a *weed knife*, fig. 224. This consists of two knife-edged blades, hinged to form a V-shaped tool, and is likewise adapted to the naturalist's walking stick. When it is desirable to obtain mud, shells, or other objects out of the reach of the walking stick, the *microscopist's dredge*, fig. 224, may be advantageously employed. This is made after the manner of the larger one, described further on, and figured in pl. XXXVI, fig. 228. The dredge is attached to one end of a length of stout whipcord, the other end being formed into a loop is passed over the collector's foot, the intermediate length of string is carefully laid on the ground, coil upon coil, and the dredge is then thrown far into the water, and drawn over the bottom of the pond as it is dragged to shore.

Certain Desmids, Diatoms, and other objects which float upon the surface of water, are best secured by means of a *skimming spoon*, fig. 224. All these appliances are packed by Mr. Highley into a little pocket case measuring 7 by  $2\frac{1}{2}$  by  $1\frac{1}{2}$  inches. A companion *collecting case* to this, contains six corked tubes and a pair of forceps. All objects of a similar kind should be selected by

means of the pipette after each haul, and placed together in one tube, especial care being taken that no larvæ, likely to devour the specimens, be accidentally placed among them. To provide against collecting too many of the same species, it is as well to examine portions taken from questionable hauls by means of the waistcoat pocket microscope, designed by Mr. Highley, and figured in pl. VIII, fig. 37. In some cases a pocket lens may be employed. The inconvenience of holding the head upwards to the light in using the lens may be avoided by placing the object on a reflecting prism, as suggested by Mr. Becker. This idea has been further carried out by Mr. Highley in his *reflecting live cage*, fig. 225, which consists of a plate of brass having an aperture into which a piece of thin glass is cemented, fitting by spring sides on to a rectangular prism, so as to permit varying degrees of pressure upon an object, or drop of water placed between the two glass surfaces. The top surface of the prism being held horizontally, or nearly so, light is projected from the reflecting plane of the prism through the object to the eye; Mr. Highley has adopted for this arrangement a form of lens giving a larger field of view in relation to the magnifying power than the ordinary Coddington lens.

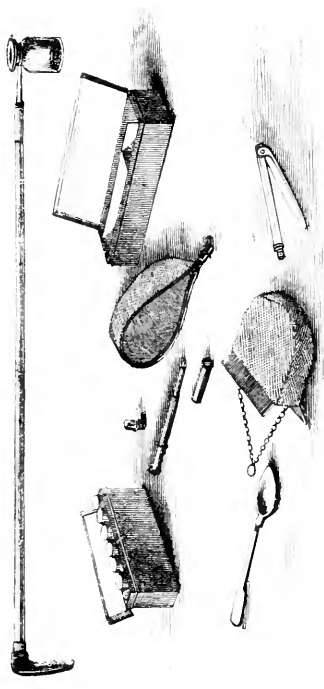
The implements already described are also employed for shore collecting; but for the purpose of removing objects attached to rocks, or the sides or bottoms of rock basins, a flat-faced geologist's *trimming hammer* and a *cold chisel* should be added.

For sea collecting, the *surface net*, the *draghook*, and the *dredge* are employed.

The *surface net* is a double conical bag made of "cheese net," or "bunting," stretched upon a cane hoop, and supported by three pieces of cord, brought together at the point at which the towing cord is attached. The inner cone is more obtuse and shorter than the outer, and prevents objects once caught from being washed out again. At the bottom of the bag is fixed a glass bottle, and a bung is attached about a foot above it, to prevent it from sinking too deep. Mr. Highley likewise advises that corks should be so placed at the mouth of the hoop as to insure the net being only half immersed, and the hoop being pulled into an oval form, so as to present a wider mouth to the waves than when left circular. This net is towed astern or at the side in such a way as to be clear of the boat's or ship's wake, and the length of line is regulated to the strain created by the speed of the vessel. On drawing up the net, the bottle is thrust up through the hole in the inner cone, and its contents emptied into a bottle of similar size, with a screw cap, of which some dozen should be kept in a tray. Many interesting forms of crustacea, acalephæ, medusæ, &c., can only be secured by this means.

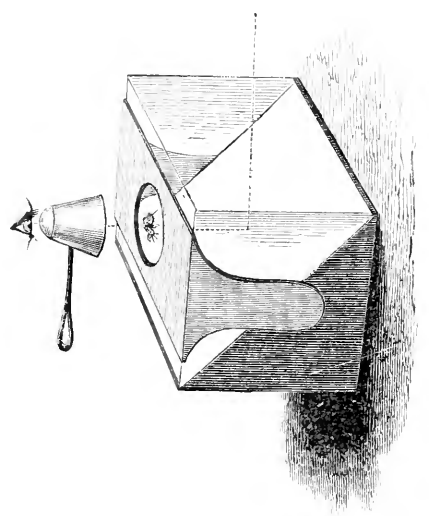


FIG. 21.



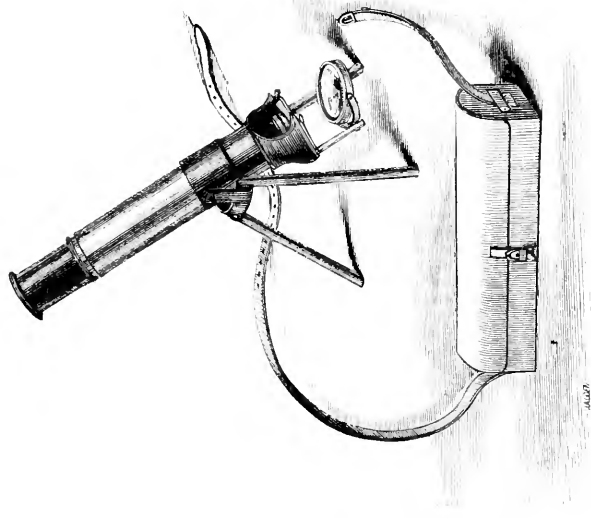
Instruments and apparatus for collecting aquatic insects, plate xxxv. p. 117.

FIG. 235.



Modified condole box arranged by Mr. Hestley p. 215.

FIG. 276.



Field microscope (J.J. Leigley) and case, p. 130.



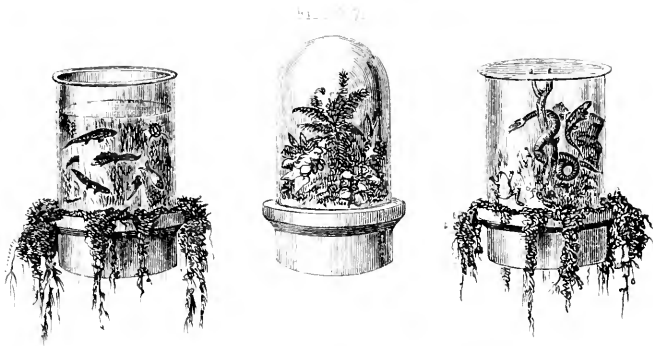
*The Draghook*, fig. 230, consists of three groups of stout iron hooks welded to a horizontal bar having an eye in the middle, to which a stout rope is fixed. This is let down among the roots and fronds of the coarse seaweed, on which many microscopic animal and vegetable forms are parasitic, and when entangled is hauled up with the captured specimens.

*The Naturalist's Dredge*, fig. 228, however, produces the richest harvest from the sea. It is made of a wrought-iron rectangular frame, from which two *scrapers* project at an angle, on each side, and to which two handles, terminating with four links of chain, are hinged to each end so as to allow of some freedom of motion, and the dredge being easily packed into a small space. To this frame a fine-meshed tanned net is fixed by copper wire, and to prevent this from being caught when dragging over a rough sea bottom, it is guarded by two flaps of coarse sail cloth which hang on either side. The mouth is made narrow to prevent heavy stones from entering. A rope strong enough to anchor the vessel in smooth water, and long enough to prevent the dredge skimming or bumping over the bottom, yet not so long as to allow it to bury itself in soft sand or mud, is required. Its length should be about double the depth of the water dredged. The rope should be firmly tied to *one ring only*, and then the ring of the other handle should be braced to its fellow by a piece of spun yarn, so that in the event of the dredge fouling, by putting extra way on to the boat the string will yield and allow the two handles to open, and thus the dredge will easily free itself. On lowering the dredge, it is evident that it is a matter of indifference which side rests on the ground, and in this lies its advantage over the common dredge. It may be used in a rowing boat in smooth shallow water near shore, but a small sailing boat is preferable in depths over ten fathoms. The towing-rope is coiled up at the bottom of the boat, and its free end is made fast to one of the cross seats. The dredge is thrown over to windward near the stern, and when sufficient line has run out a turn or two is made round a "belaying-pin" to make it taugt. The line should be held in the hand so that the owner can feel at once if anything goes wrong. When the dredge is lifted, its contents should be emptied into a *sorting tray*, fig. 229. This consists of a coarse wire sieve C, which retains all large specimens, stones, &c., but allows small or delicate ones to pass into a perforated zinc sieve F, which retains all objects over  $\frac{1}{4}$ -inch diameter, but allows the sand or mud to be washed into the lower tray which is furnished with a double bottom formed of fine webbing stretched on a frame. The water poured over the sieves to facilitate this operation is carried off by a flexible tube. Mr. Highley makes all these trays

to pack into each other and hold the dredge, drag hook and surface net and the outer tray being provided with a lid and straps, forms a packing case for the outfit. A convenient form of portable microscope with an inclinable body, &c., suited for dredging excursions, or for a shore-collecting sea-side expedition is shown in fig. 226.

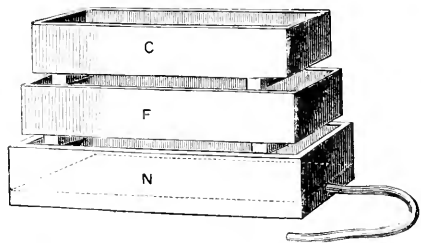
The collector should examine stagnant pools, ponds, rivers, boggy ground, rock pools and basins on the sea shore, carefully searching the sides and bottoms, the fronds of plants, or pieces of wood floating therein, for gelatinous or spongy masses, or palpable forms of vegetable or animal life, not forgetting to examine with a lens all scums floating on the surface of water, to see if they consist of, or have entangled, objects worth preservation. Filamentous *Desmidiæ*, if diffused through the water must be collected by aid of the gauze net. When gelatinous or cloudy masses are adherent to the fronds of water plants, the hand should be passed gently into the water, palm upwards to form a cup, and the fingers closed on each side of an invested leaf or stem; the hand should then be drawn upwards, so as to allow the plant to slip through the fingers close to the palm with an easy equable motion, care being taken as to how the hand is raised from the water, lest the captives should be washed out of the concave palm. Water resting in the indentations made by the feet of cattle, should not escape notice. The side of a pond towards which the wind is blowing, is always the most prolific, especially if the sun is shining on the same side, and the shallow parts are richer in spoil than the deep on account of being warmer. The collector who means work should encase his legs in waterproof wading boots and follow the sea out as it recedes at the low spring tides, when the greatest amount of shore is left uncovered. The months of March and April, September and October having the lowest tides in the year are the best for the purpose of shore collecting. Those parts of the coast should be selected which are neither too hard like granite, nor too soft like chalk, but such as favour the formation of ledges, crevices, rock pools, and basins, heaps of *debris*, and outlying caverns.

Holes in the sand should be searched for case building worms or boring mollusks. Large fish or marine animals left stranded by the recess of the tide should be examined for parasitic crustacea, &c., especially the gill-covers of fish. The masses of olive sea weeds covering the rocks should be turned over, or when hanging pendant from overhanging slabs, they should be turned back as they generally shield such forms as attach themselves to the surface of rocks, as starfishes, ascidians, nudibranchs, eggs of mollusks, *Alcyonia*, tube forming Annelids, Sponges, &c. Crevices should be searched for



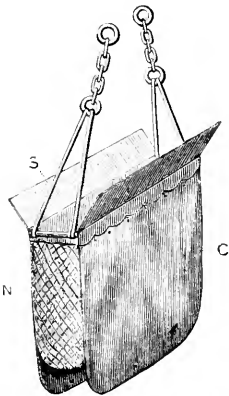
Small terraria and fern cases. p 154

Fig. 299.



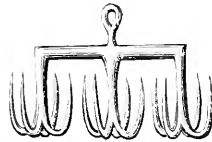
Washing sieves C and F and drum net N. The drums have 3 rods each. Fig. 299 net. Fig. 331, all pack into N. Designed by Mr. Higley. p 159.

Fig. 300.



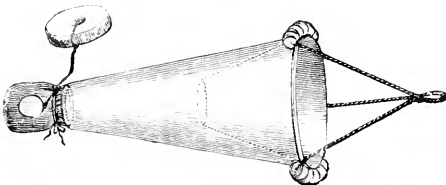
Marshall's drizzle, as described in pack in N. Fig. 300. p 159.

Fig. 350.



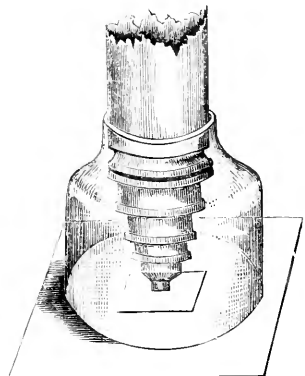
This hook for tearing sea-weeds up by the roots. p 159.

Fig. 351.



Drum net improved by Mr. Higley. p 159.

Fig. 352.



Pickling-Jensen's moist chamber. p 156



crustacea, starfishes, echini, wandering annelids, waterworn nodules for investing social ascidians, such as the Botryllidæ, or multivalve mollusks, such as chitons. Loose stones and large boulders should be turned over, as many crustaceans and annelids take refuge beneath them. Large tufts of corallina and other sea weeds should be gathered from the edges of pools near low water, and placed in a jar of water as they harbour Entomostraca, Pycnogonidæ, Lucernaria and other zoophytic forms. Outstanding rocks only uncovered at the lowest spring tides, and then usually only approachable by boat, should be visited in the hope of finding the only British representatives of the stony corals. Beyond such points, the sea bottom must be ransacked by means of dredge and draghook.

**247. Vivaria and Aquaria.**—Many of the lower animals and plants may be kept living in glass cases and glass jars, and will grow and multiply in confinement. Frogs, newts, lizards, many mollusks, insects and worms, air-breathing and aquatic, will live for a length of time in confinement, and some flourish.

Vivaria are now made of various forms and sizes, and many of them are most ornamental. The student may easily arrange such for himself for a few shillings, and may keep a number of objects of the utmost interest which will provide him with endless amusement and constant work.

Cases for breeding insects and keeping them alive may now be obtained of many naturalists.

Frogs, toads, and newts may be kept in glass cases to the interior of which air has access through wire gauze. At the lower part should be some water which may be placed in a saucer or basin with shelving sides. This may be made ornamental and adapted for plants if desired.

Fresh water aquaria may readily be formed by inverting propagating bell glasses, carefully selected as to shape, in a turned wooden stand or in fern dishes which have been filled with earth or sand. The bottom of the bell-glass should be filled with rich black peat earth, worked into a paste, and this should be covered with a thick layer of fine well-washed shingle. Roots of vallisneria, anacharis, or chara may be then planted in the earth and the vessel carefully filled up with water. After the water first introduced has become quite clear a few fresh-water mollusks should be added to keep down the growth of confervæ. Those species which feed rather upon decayed vegetable matter than upon the plants themselves should be selected, such for instance as *Planorbis corneus* or *carinatus*, *Paludina vivipara*, or *Amphibia glutinosa*. When the water has cleared and the plants are in good condition, which may be known by their

giving off bubbles of oxygen gas, fish, water insects, &c., may be introduced. A plant or two of the floating "Frogbit" is useful for giving support to such species as come occasionally to the surface.

In the case of both fresh-water and marine aquaria it must be borne in mind that a proper amount of light is required which should be admitted from above as well as on one side of the vessel. If there is not light enough, the plants droop and do not give off air bubbles, while if there is too much light there will be a more abundant growth of confervæ upon the sides of the vessel than the scavenger molluscs can keep under. It must also be borne in mind that animals must be kept in what has been called "amicable groups," or wholesale destruction will ensue.

Minnows, sticklebacks, and eels, are the fish best suited for fresh-water aquaria, but of course must not be kept in such as are used for watching the various stages of development of other animals. Small eels are most interesting objects, and the student will be interested in watching the pulsations of the venous heart in the tail of the animal.

Marine aquaria require more attention in their construction than those for fresh water, and as a greater variety of forms may be associated they should be made large. A marine aquarium, capable of holding from five to ten gallons, is a convenient size and will succeed well. The bottom and sides should be of slate, the back and front only being of glass cemented into grooves made in the slate, not simply abutting against a shoulder and cemented, or a continual leakage may occur. I have made excellent joints with the aid of the lime and India-rubber cement, p. 52, to bed the glass in, this being covered with a mixture of white and red lead forced in together with some fine tow or cotton wool. The aquarium should be covered with a glass top fitted to a beading of perforated zinc, so as to admit air but keep out dust. The form should be such as to allow a large area of surface to be in contact with the air in relation to the bulk of water. Rock work should be built up at the back so as to cut off an unnecessary amount of light, and should be arranged in such a way as to present tiers of resting places for the animals. The basis may be formed of coke which is advantageous on account of its lightness, but this is to be faced with flakes of granite, limestone, and sand rock, put together with hydraulic cement to produce a more picturesque appearance. It is, however, better not to use cement at all.

The tank so far prepared should be first filled with fresh water to remove all soluble matters from the cement and rockwork. After resting for a day or two, the water must be drawn off with an India-rubber



tube used as a syphon, and the bottom covered with well-washed shingle. The tank may then be filled up with sea water, or artificial sea water may be made with Tidman's sea salt in the proportion of about one pound to three gallons of water, the exact proportions being determined by aid of a hydrometer, which should stand at 1.026. Should the water be too salt the stem will rise till perhaps 1.030 of the scale appears above the level of the water, in which case more common water must be slowly stirred in. If on the other hand there is not sufficient salt, the stem will sink towards 1.020 and more salt must be added till the hydrometer registers the proper specific gravity of natural sea water. As evaporation causes the water to become concentrated, it should from time to time be tested with the hydrometer and the necessary amount of water added. The next step is to get the rockwork covered with the spores of seaweeds, by placing several small healthy tufts of *Ulva*, or *Enteromorpha* in various parts of the tank where they are fully exposed to light. In a short time minute vegetable growths will make their appearance all over the tank. The growth on the front glass must be removed as fast as it is formed by a sponge tied to a stick. After this growth has appeared the tufts of weed may be removed. The amount of light admitted to the tank must now be carefully attended to, so as just to cause the evolution of bubbles of oxygen, without stimulating the vegetable to an over-abundant growth which would cloud the water. Animals may next be introduced slowly and not in too great numbers, the lowest in organisation first, the higher forms when the tank is evidently working well, and the first things introduced appear healthy, and the water is clear and sparkling. It is well occasionally, if not daily, to remove a portion of the water into a glass vessel and allow it to return to the tank through a fine jet, by which means the water is broken up into spray as it returns to the tank. There are various ways of effecting this important process of aeration of the water.

In the Athenæum for March 10th, 1860, Mr. Highley described a very convenient aquarium arrangement well suited for a microscopist who is making a temporary visit to the coast, which I here extract.

“I may mention a plan I have employed with great success when making temporary visits to the coast, which will be found very convenient to those who wish to classify the animal forms obtained for observation. I take a nest of German beakers (without spouts) and pack them in a zinc case: on my arrival, I fill them with fresh sea water, and place them in a sunny window; I then collect a number of limpets on whose shells *enteromorpha* and *ulva* are growing. These will be found to be small but vigorous plants. I remove the animals from

the shells, and then drop one or more alga bearing shells into each beaker according to its size; in a short time the sides of the jars, especially the sides turned towards the light become coated with spores; the sides turned from the light I keep clean with a chisel-shaped piece of wood and a knob of sponge, so that whilst one half of each jar is covered with a green oxygen yielding coat, the other half is free for observing the animals that may now be placed in the beakers. Behind this protecting coat, red algæ will be found to thrive. In this way a number of aquaria may be speedily provided for our collections that will keep healthy for months, with the slightest amount of attention.

After the sides are properly covered with spores, the sea-weeds should be removed and the jars placed on a table at such a distance from the window that the light impinges only on the coated half, taking care, however, that there is sufficient to stimulate the spores to throw off bubbles of oxygen daily. If on leaving a place I wish to take any specimens away with me, I pack these beakers containing them in a rough box, of a size suited to the number selected, with seaweed between the interstices and at the latest moment tie bladder over each jar, which I remove at the earliest opportunity after arriving at my destination."

Prawns, fish, actinæ, &c., may be fed on shreds of beef, which has been pounded and dried, and then macerated in sea water for a few minutes before use. All dead animals, slime, or effete matter should be removed by means of a pair of long boxwood forceps or small saucer, as soon as noticed. With a moderate amount of attention, a marine aquarium may be kept for years (ten or more) without changing the water. Microscopes are specially constructed by Mr. Highley, Mr. King, and Mr. Salmon, for observing animals within aquaria. See p. 13.

The most useful books to the microscopist visiting the coast, will be found in the list at the end of the volume.

**248. Examination of Lower Animals during Life.**—Many of the lower animals may be examined in the living state, and numerous interesting and important facts may be demonstrated. The student will find many of the smaller insects, more especially the aquatic larvæ, as for example, those of the common gnat, well adapted for this purpose. Small crustaceans, as the daphne and some of the fresh water shrimps are exceedingly interesting objects, and are easily subjected to examination in the living state in the animalcule cage, p. 66, or under a compressorium, p. 81.

*Examination of Infusoria, &c.*—Suppose the student desires to submit some of the animalcules in water to microscopical examination, he may proceed as follows. A drop of the water is to be removed

with a pipette, or upon a glass rod, or with the finger, and placed upon the glass slide. A bristle or thin piece of paper is placed in such a position as to prevent the thin glass from coming into too close contact with the slide; or the drop may be placed in a Brunswick black, or thin glass cell; or the animalcule cage already described, pl. XVIII, fig. 112, may be used with advantage. By the latter instrument, and also by the compressorium, p. 81, the larger infusoria may be kept still in a particular position for the purposes of examination.

Fresh-water and marine zoophytes, too large to be placed in the small cells, or the troughs, p. 66, may be examined in flat watch glasses, or in one of the larger cells, represented in pl. XVIII. These may be examined with low powers (two inch, one inch) without any thin glass cover, but where the higher powers are employed a piece of thin glass must be applied in such a manner as to cover that part of the vessel in which the animals are situated, while at the same time a certain proportion of the fluid is freely exposed to the air; for if aeration were prevented, the animals would soon exhaust all the air dissolved in the small quantity of water in which they were imprisoned, and die of suffocation.

It is difficult to kill many zoophytes, and preserve them with the tentacles extended, but it is said that the retraction of the tentacles may be prevented by plunging them into cold fresh water. Various poisons, opium, hydrocyanic acid, chloroform, &c., have also been recommended for the same purpose, but a voltaic current effects the object most perfectly.

*Vorticelle and Rotifers* or wheel animalcules, may often be obtained by placing a small piece of a plant which has been allowed to remain in the same water for some time, with a drop of the fluid in a glass cell. These organisms are often found attached to the edges of the plant in considerable number.

Cheese mites and other small acari should be examined with low powers (two inch, one inch) under the binocular, a strong light being condensed upon them with the aid of the bull's eye condenser or the parabolic reflector, p. 21.

The *Entozoon* or *Demodex folliculorum* may be obtained by squeezing the sebaceous glands in the skin of the nose or scalp of the human subject. If transferred to a little oil and covered with thin glass the animals may be preserved alive for some time and their slow sluggish movements watched. Specimens may generally be obtained from the wax of the ear. Small spiders, many of the minute coleoptera and their larvæ, aphides, and a great number of the smallest insects common in fern cases may be easily examined, and some of the smallest of them are suitable for examination by reflected

and transmitted light under high powers, with the aid of the binocular, p. 11.

**249. Of keeping Bodies moist while under Microscopical Observations.**—In order to study the changes occurring during the growth and multiplication of some of the simplest organisms which live in water, it is necessary to adopt some plan for preventing, or compensating for, the evaporation which takes place. This may be effected, as recommended by Recklinghausen, by adapting a piece of sheet India-rubber tubing to the glass ring fixed on an ordinary glass slide, the diameter of the ring being sufficient to allow a piece of thin glass to be placed within its circumference. The upper end of the tube is tied round the object glass of the microscope. Thus a *moist chamber* is made, and if one of Hartnack's "immersion lenses" be employed, observations may be continued upon a given object for some time. The moist chamber is, however, better adapted for use with low than with very high magnifying powers. See pl. XXXVI, fig. 232.

I have found that the same object is gained if the loss of fluid by evaporation is compensated for by a little reservoir of water, fixed at one end of the slide, from which a small piece of blotting paper or silk thread conducts the fluid to the object as fast as evaporation takes place. By placing a little cement round two thirds of the thin glass cover, sufficient space is allowed for the requisite access of air, while at the same time loss by evaporation is reduced to the smallest amount. By this arrangement the growth of the spongioles of plants can be studied very successfully.

A small quantity of fluid or semi-solid matter containing various kinds of living matter, may be preserved for some days without the death of the living matter it contains taking place, by the following arrangement. A small glass tube about half an inch in diameter and an inch and a half in length is prepared, the edge of one extremity being turned outwards in the blow-pipe flame, so that very thin membrane may be tied over it. The tube is so arranged that the membrane just touches the surface of some distilled water in a small dish or capsule. The whole may be placed in a hot-air oven maintained at a temperature of 100° F. In this way I was enabled to keep living matter freely exposed to the air, whilst evaporation was compensated for by the gradual imbibition of fluid from below through the pores of the membrane. I have succeeded in preserving masses of germinal matters from the higher organisms alive for a considerable time longer than they would have lived at the ordinary temperature of the air.

**250. Of Keeping Bodies at a Uniform Temperature higher than the Air, while under Microscopical Observation.**—By placing a brass

plate upon the stage of the microscope, and allowing one end to project over the edge so that it may be conveniently heated by a spirit-lamp, any substance may be kept warm upon a glass slide, while subjected to microscopical examination. Max Schultze has recently contrived a brass plate which is fixed by clamps to the stage of the microscope, and extended at the sides so as to form two projecting arms beneath each of which a small spirit-lamp may be placed. A hole is made for the transmission of the light, and close to the place where the slide with the object is situated, is the bulb of a little thermometer, the stem of which is so arranged that the degrees can be easily read off. This apparatus has been made by Geissler, of Bonn, fig. 233, pl. XXXVII. In conducting observations upon bodies which are warmed, the loss of fluid from evaporation must be provided against by the use of the moist chamber and immersion lens, or by the little reservoir and conducting thread, pl. XVIII, fig. 111\*, or by the arrangement described on p. 156.

Dr. Ransom, of Nottingham, has been long engaged in investigations which require the application of heat and cold to the object while under observation. He says, "The mode of using heat for those examinations I have found best so far, is recommended by M. Schultze, only in order to employ with it cold also, I have ordered one to be made of copper instead of brass as the former metal is so much better a conductor, and I trust I shall be able with this new hot stage to preserve an object at any required temperature, and to read off easily the actual temperature which the object has from 30° F. to 160° F." The principle of this new hot stage is to conduct the heat to or from the object, and not to use currents of air or water. It may be used not only for stimulating movements, but for watching the extremes upwards or downwards, which either arrest them or destroy them. Such a stage must be separated from the microscope by a non-conducting substance.

Sometime since, I adopted a plan for heating objects by hot air—this will be understood by reference to fig. 234, pl. XXXVII, but for most purposes Max Schultze's apparatus is to be preferred.

#### *Of the Tissues and Organs of the Lower Animals.*

For the most part the tissues of the lower animals may be examined according to the same plans recommended for the demonstration of the structures of the higher classes. In this department, however, the student will meet with greater variety of texture, and in not a few instances our knowledge of higher structures may be greatly advanced by the careful study of the corresponding tissues in the lowest classes. There are many textures which are peculiar to the lower animals which

are well deserving of the careful attention of the microscopist, and especially in researches upon the changes occurring during the development of tissues, facts may be ascertained which cannot be made out by investigations among the higher classes.

**251. Of Preparing the Tissues of Insects for Microscopical Examination.**—Many of the smaller insects may be mounted entire as dry objects, but the hard external covering of the body and limbs in many members of this class is better displayed if freed from the soft parts and preserved in Canada balsam. Moist tissues may be entirely removed by the action of liquor potassæ in which they are perfectly soluble, and the hard textures are at the same time softened by the reagent. After very careful washing in distilled water the entire insect or parts of it, may be dried in the position they are intended to take up permanently. They are then to be moistened with turpentine and mounted in Canada balsam. The chloroform solution, p. 50, of the latter substance may be employed with advantage. For the details of the operation the reader is referred to Mr. Thomas Davies' little book on "The Preparation and Mounting of Microscopic Objects," p. 68.

*The Egg Capsules* of insects exhibit very peculiar markings upon their surfaces which vary in every species, and even in those which are closely allied the greatest difference often exists. Insect ova are represented in pl. XXXVII, fig. 237. The eggs may be examined as opaque objects according to the methods described in p. 21, or very thin vertical and horizontal sections may be made and mounted in fluid or in Canada balsam. Upon one surface of the eggs of many insects, and very readily in some of the lepidoptera, an orifice surrounded with beautiful markings may be discerned. This is the micropyle.

**252. The Scales and Hairs** from many insects and crustacea are well worthy of attentive examination. The scales from the wings of various butterflies and moths form beautiful objects. They should be examined in a dry state and also mounted in balsam. The student will find that the scales of different parts of the body exhibit great varieties of structure, while those of no two species are exactly alike.

The markings upon many of these scales are so delicate as to serve for testing the defining powers of the highest and most perfect object-glasses. Some of the most elaborate are obtained from the *podura*, a little hopping insect, common enough in some localities among old dry wood. In order to catch the *poduræ*, Dr. Carpenter directs that a little oatmeal be placed on black paper and left some hours, when it may be transferred to a large clean basin, out of which the creatures cannot leap. Their scales may be mounted dry, in fluid, or in balsam.

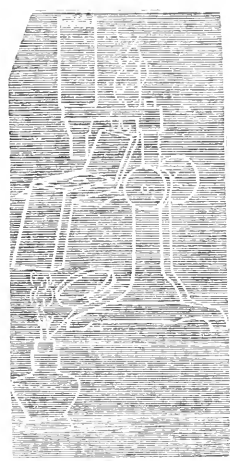
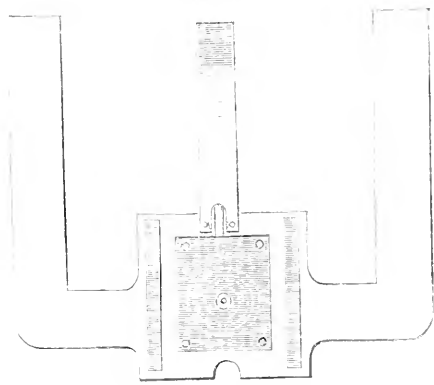


Fig. 5

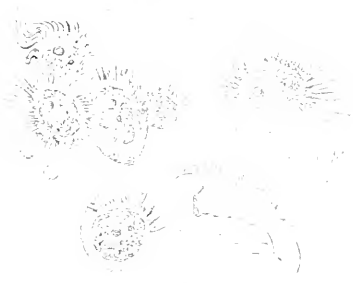


Fig. 7







**253. Tracheæ**, or air tubes which are characteristic of the class of insects may be demonstrated very readily. If the inside of a common maggot, caterpillar, or fly be removed and covered with thin glass, numerous exceedingly fine dark lines will be seen ramifying almost everywhere, and forming networks. These are the tracheæ, and their black appearance is due to their containing air which refracts the light very differently to the other tissues and fluids by which it is surrounded. The explanation has been already given in the case of the lacunæ and canaliculi of bone, in p. 78. But in this rough mode of examining the tracheæ, the student learns nothing concerning the elaborate structure of these air-tubes. If some of the larger ones be dried and then mounted with turpentine or Canada balsam, it will be found that a spiral thread is closely coiled around every one of the tubes, by which beautiful arrangement all are kept pervious, so that air may circulate freely through them, and thus reach the ultimate constituents of all the textures of the body.

The tracheæ all open upon the surface of the body, by orifices termed *spiracles*, easily found in the common caterpillar, as they form a row on each side of the body. Every spiracle is guarded by a comb-like arrangement of firm chitinous or horny tissue which prevents foreign particles from passing into the tracheæ, while like a sieve it permits the free ingress and egress of air. The student should mount a series of specimens of spiracles from different insects.

**254. Branchiæ of Mollusca.**—The textures of which this form of breathing apparatus is composed may be demonstrated according to the principles already laid down in the sections upon the tissues and organs of the higher animals. The arrangement of the vessels may be displayed by injection, p. 103. The method of demonstrating the circulation of the blood in these organs has been described in page 134. In many young mollusks the branchiæ are very beautiful. The action of the cilia with which the vessels are clothed is referred to in p. 161.

**255. Microscopic Shells** from beautiful objects for investigation; many may be mounted as dry objects, and examined by low powers. The remains of the animal organisms may be removed by boiling for a few seconds in a weak solution of potash or carbonate of potash. The shells must then of course be thoroughly washed in successive portions of distilled water.

The shells of foraminifera, many of which are to be found upon our ordinary sea weeds, may be prepared in the same way. This class of organisms has recently been very carefully investigated by Dr. Carpenter, whose beautiful memoirs in the Phil. Trans. are worthy of attentive study. See also "The Microscope and its

Revelations," by the same author, and papers in the Microscopical Journal.

**256. Contractility of Muscle.**—The actual movement taking place in the particles of this tissue may be demonstrated in certain of the lower animals, in which it continues for some time after the tissue has been removed from the body. Muscular contraction may be studied in small insects or crustacea. Mr. Bowman strongly recommends the muscular fibres from a young crab (Phil. Trans. 1841). Many small transparent aquatic larvæ are also very favourable for this purpose.

The phenomena of muscular contractility may be most successfully studied in the broad muscles just beneath the skin of the common maggot or larva of the blow-fly, and as these can be always readily obtained, I recommend them for observation. The movements, which are very beautiful, continue for ten minutes or a quarter of an hour after the muscles have been removed from the body of the recently killed animal, so that a specimen may be prepared and passed round the lecture room in one of the portable microscopes, p. 14. In the winter I have seen the contractions continue for upwards of half an hour. It is most instructive to examine these muscles during contraction under the influence of polarised light, with a plate of selenite. When the ground is green, the waves of contraction which pass along each muscular fibre in various directions, are of a bright purple. In other parts of the field the complementary colours are reversed. There are few microscopic objects, that I am acquainted with, so beautiful as this. With the aid of very high powers, the actual change occurring in the contractile tissue as it passes from a state of relaxation to contraction, and from this to relaxation again, may be studied, and for many minutes at a time.

In order to obtain the muscles, it is only necessary to slit up the larva, and after removing the viscera, to separate some of the muscles from the outer skin to which they are attached. They may be moistened with some white of egg, saliva, or better than all, a little of the colourless fluid from the animal.

In this way the student will form a good idea of the nature of *contractile* movement generally, in which there is repetition. Contractility has been confused with movement essentially different in its nature, which takes place in germinal or living matter, p. 170. The first affects various kinds of formed material only; the last is peculiar to germinal matter. Contractility is essentially interrupted. Vital movement is continuous. By the last, a weight may be raised higher and higher, and if the weight increases the force which raises it may increase also. Contraction involves yielding or relaxation. It is, as

it were, a vibration to and fro—the alternate shortening and lengthening of a fibre. Contraction takes place in one definite direction only, and never alters. Vital movement may occur in a mass of living matter in any direction. *See* also p. 169.

**257. Ciliary Movement.**—Although this kind of movement is not peculiar to animals, but is also found among plants, at least during the early stages of existence of some of the lower forms, it will be convenient to consider the methods of demonstrating cilia in an active state of vibration in this place.

Upon certain surfaces in the higher animals, and to a greater extent in the lower classes, we find that the cells which generally form the outer protective covering of more delicate structures, are provided with very active vibratile processes, or *cilia*, which by their movements create currents often of some considerable power. These movements are sometimes required to promote the rapid removal of foreign bodies which would injure delicate surfaces if they came in absolute contact with them, or for promoting a constant change in the water by which the animal is surrounded. Cilia effect the latter object in the greater number of shell fish, which are stationary throughout life, and are not provided with an apparatus for promoting a continual change of the fluid which bathes the surface of their respiratory organs.

*Ciliary Motion* endures for a longer or shorter period after death, and is entirely independent of the nervous system. In the active bird it ceases very soon, but in the more slowly nourished, cold-blooded animals it often lasts for many days after death.

Different forms of ciliary action may be observed among the different species of infusoria. It is, however, doubtful if many of the very fine spine-like bodies, the movements of which seem to be under voluntary control, should be regarded as cilia. The simple organisms of this class seem to possess the power of stopping the vibrations, although there can be no doubt that in vertebrate animals ciliary action is quite independent of volition. There is certainly no connexion between the cells of ciliated epithelium and the nerves.

Cells with ciliated epithelium in active vibration can always be obtained by scraping the back of the frog's tongue. Mucus is removed in which numerous cells are found. The thin glass cover must be prevented from pressing too firmly by inserting a small piece of thin paper beneath it. The student may also obtain very beautiful ciliated epithelium in active vibration from the branchiæ (gills) of the oyster or mussel. Some of the cilia from the latter situation are of very considerable length, and occasionally the vibration of a

single cilium may be watched, in which case the observer may demonstrate the interesting fact that movement occurs not only at the base of the cilium, but in every part of the vibratile filament.

Of all the ciliated structures, the newt's kidney is perhaps the most beautiful and the most remarkable. The tortuous uriniferous tubes in the upper thin portion of the kidney are lined in their whole length with ciliated epithelium, which continues in active motion for some time after the removal of the organ from the body of the animal. In order to display this wonderful object, we must proceed as follows:—After destroying the newt by decapitation, the abdominal cavity is laid open, and by turning the viscera to one or other side, the kidneys may be exposed. Towards the pelvis, the kidney presents much the same appearance as in the frog: but, upon tracing it upwards, it will be found to become gradually thinner, and to extend quite into the thoracic portion of the animal. It is this upper thin part of the kidney which shows the ciliary motion to the greatest advantage. See pl. XXXIII, fig. 218. A probe, *a*, is represented in the drawing underneath that portion of the kidney which should be examined in the microscope. The secreting tubes lie upon one plane, so that a tube, throughout the entire length of which active ciliary motion is constantly taking place, may often be seen in the field of the microscope at one time. A more beautiful object under a half-inch object-glass, can scarcely be conceived. The thin portion of the kidney, above referred to, is to be very carefully removed from the body by delicate manipulation with fine forceps and a pair of scissors, moistened with a little water, or, what is still better, with some of the serum of the animal, placed in a large thin glass cell, and carefully covered with thin glass. The cell should be sufficiently thick to prevent any pressure upon the preparation. After ciliary motion has stopped, the cilia are with great difficulty distinguished. Many of the tubes in the lower thick part of the kidney do not exhibit ciliary action perhaps because the cells are undergoing degeneration. I have been able to find tubes in every stage of wasting in newts which have been kept in confinement.

Ciliated epithelium may be obtained from the larynx and trachæa of man by coughing violently. The vibration occasionally continues for some time after the specimen has been transferred to the glass slide. The observer will be surprised at the enormous number of cilia projecting from a single cell; indeed it often happens that a mass is expelled which seems to consist of hundreds of long filaments, all in active vibration, radiating from a common point.

Ciliary action is, I think, due to changes going on within the cell, but probably very intimately connected with the currents which

flow to and from the germinal or living matter, and the altered tension thus caused in the cell. Ciliary motion is not dependent upon nervous action, nor is it due to any disturbance in the surrounding medium. It cannot, I think, be regarded as a *vital* movement, although it is probably due to changes which are consequent upon vital phenomena. Cilia consist of "formed material." In the immediate vicinity of ciliated cells are sometimes observed cells with open mouths, out of which mucus and various substances, formed or secreted in the interior of the cell, pass. In the formation of these products, nutrient matter from the blood, after passing through the attached extremity of the cell, is probably absorbed by the living matter. At the same time the outermost portion of the latter becomes converted in the peculiar contents of the cell, and thus the formed matter which has been already produced becomes pushed towards the orifice. *See* the new edition of "The Physiological Anatomy and Physiology of Man." I think that the movements of cilia are brought about by a somewhat similar series of changes, in which the germinal or living matter, usually termed "nucleus," plays the active and most important part.

#### OF DEMONSTRATING THE TISSUES OF PLANTS.

**258. Examination of Vegetable Tissues.**—The examination of vegetable tissues is conducted upon the same general principles as that of animal textures. The spiral vessels of plants can in many instances be obtained by boiling the stem of the plant for some time in water. Those of rhubarb are very large, and may be selected for examination.

The spiral vessels in leaves may be beautifully shown by allowing some coloured fluid to enter them. If the stalk be placed in the fluid and evaporation from the surface of the leaf be encouraged by exposure in a warm place, the fluid will enter the vessels. If carmine fluid, p. 109, be used, the germinal matter of the cells near the vessels is stained at the same time that the tubes are injected.

Thin sections of soft vegetable tissues in any direction may be very easily obtained with a very sharp knife. The method of cutting thin sections of woods has been already referred to in p. 84. The cellular tissues of plants (certain leaves, flowers, fruits) are softened and at length destroyed by weak nitric and hydrochloric acid (one part of acid to from twenty to fifty of water), while the fibrous and vascular textures remain behind, constituting the skeleton of the leaf, flower, calyx, or fruit.

Almost all vegetable tissues are most easily investigated when they have been preserved for some time in viscid media, which are miscible in all proportions with water. Leaves and stems when well saturated with syrup or glycerine are easily dissected into their component tissues. They must first be placed in very dilute solutions, which may be concentrated by very gradual evaporation, or the strength of the solution may be increased by the addition of small quantities of strong syrup or glycerine from day to day. The beautiful textures to be demonstrated in jams and preserved fruits have been alluded to in p. 73.

Very hard vegetable textures, such as the shell of the cocoanut, walnut, &c., may be cut into thin sections, according to the plan described in p. 83.

*Pollen grains* are among the most interesting objects. They are easily preserved by shaking the anther of any flower fully expanded upon a glass slide, and may be mounted dry, p. 75, in aqueous fluids, p. 75, or in Canada balsam, p. 76.

*The external markings of the seeds* of plants are well worthy of attentive examination. The student may examine the seeds without any preparation whatever, as dry objects, p. 75, by reflected light. Many seeds may be at once recognised, and the species of plant to which they belong, determined by the markings on the testa alone.

*The starch globules* enclosed in the cells of many seeds and some rhizomes exhibit great variety in form, size, and structure. Different kinds of starch should be submitted to examination, and every student should be familiar with the microscopical characters of wheat, rice, and potato starch, pl. XXXVIII, figs. 239, 240, 241, arrowroot, and Indian corn.

*The colouring matters* of leaves and flowers are contained in cells, and are formed by the germinal matter of each cell. Even in petals of different plants, of precisely the same colour, different kinds of colouring matter have been recently detected by Mr. Sorby. See "Spectrum Microscopic Analysis," in part III. The petals of many flowers may be preserved without difficulty, as they retain their characters when dried. They should, however, be covered with thin glass to protect them from the dust.

If the student desires to study the manner in which the colouring matter is formed within the cell, he must examine recent specimens in glycerine, according to the principles laid down in part V.

*The crystals or raphides* found in many plants are well worthy of attentive study. They differ in composition and form in different plants, and it is even possible to recognise some species by the

Fig. 1



700

Micrograph showing several small, rounded cells, possibly spores or young cells, with internal structures. Magnification 700x.

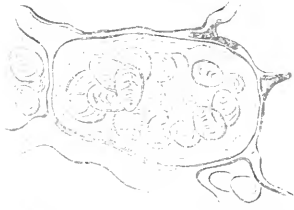
Fig. 2



1000 X

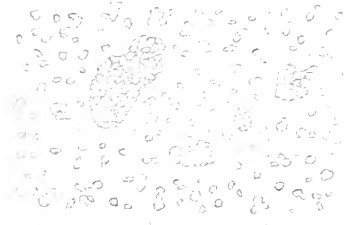
Micrograph showing numerous elongated, spindle-shaped cells, likely spores, scattered across the field. Magnification 1000x.

Fig. 3



Micrograph showing a large, rectangular cell with a thick wall and internal organelles, possibly a vegetative cell or a large spore. Magnification 1000x.

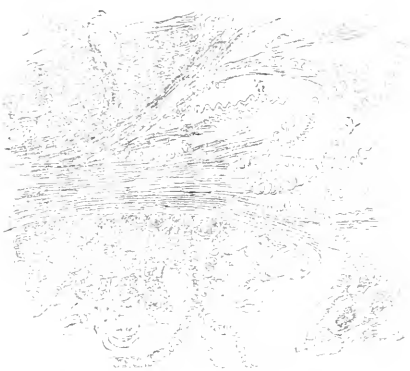
Fig. 4



1000 X

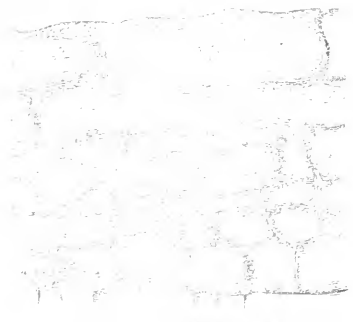
Micrograph showing a dense cluster of small, circular cells, possibly a colony or a mass of spores. Magnification 1000x.

Fig. 5



Micrograph showing a large, complex structure with many fine, radiating lines, possibly a cross-section of a filamentous organism or a large spore. Magnification 1000x.

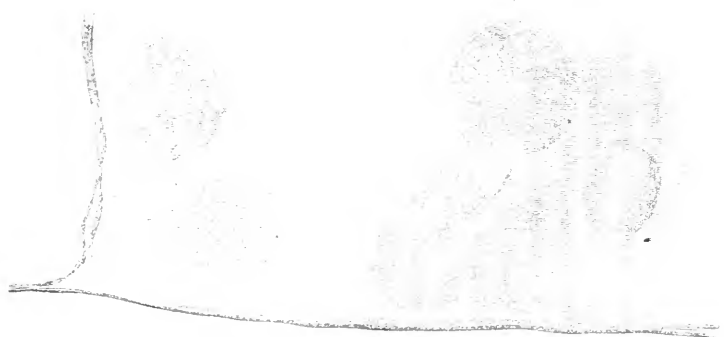
Fig. 6



X

Micrograph showing a grid-like structure, possibly a cross-section of a filamentous organism or a large spore. Magnification 1000x.

Fig. 7



Micrograph showing a large, elongated structure with a thick, curved wall, possibly a cross-section of a filamentous organism or a large spore. Magnification 1000x.





character of the crystals alone. In the bulb of the common onion, in the leaves of the hyacinth, and many allied plants, crystals may be detected. Raphides are met with in only three orders of British dicotyledons: Balsaminaceæ, Onagraceæ, and Rubiaceæ (Gulliver), but they are commonly found in many monocotyledons. In transverse sections of the thick leaves of the India-rubber plant collections of small crystals are seen in certain cells. *See* Mr. Gulliver's papers in the Microscopical Journal, especially the number for January, 1866.

**259. Of the Circulation in the Cells of certain Plants.**—The circulation or cyclosis of the contents of the *vallisneria*, *anacharis*, *chara*, and *nitella*, may be observed without any difficulty. In all these the movement is due to the *vital* properties or powers of the germinal matter which moves round and round the cell; the hard cell wall preventing its escape, and rendering movements in a right line impossible. If subjected to examination under the highest powers, however, certain precautions are necessary. The thinnest possible layer should be removed with a thin but very sharp knife, from the surface of a young leaf of *vallisneria* or *anacharis* and the two thin pieces thus obtained must be carefully placed on the slide with a drop of water and covered with the thinnest possible glass, care being taken to prevent it from pressing firmly upon the freshly cut surface.

It not unfrequently happens that cyclosis has entirely stopped in the cells submitted to examination, but after the fragments of the leaf have remained still for a short time the movement recommences, especially if slight warmth be applied; and it is a good plan, especially in winter, to place the sections which have been made in water, in a small corked glass tube, which may be carried in the pocket for a quarter of an hour or more before they are to be subjected to examination.

Facts of the utmost general interest and importance may be demonstrated in *vallisneria* by the aid of the highest powers. The stream which moves round and round the cell, and looks like pure water under a twelfth, is found to be composed of extremely minute and apparently spherical particles, endowed with active motor power, if examined by a  $\frac{1}{25}$  or  $\frac{1}{30}$ , pl. XXXVIII, fig. 244. The green chlorophyll masses are urged on by the actively moving germinal matter. One portion of the active, colourless, moving matter is seen to outstrip another portion, amongst which it gradually blends and incorporates itself, to be, in its turn, outstripped by other portions.

Solid particles are often suspended in moving germinal matter, and appear to move of themselves, although, really, they are per-

fectly passive and are but carried in the moving stream. Sometimes these are formed from the germinal matter itself, sometimes they are foreign particles entering from without. The latter may be seen commonly enough in the amœba. Pus and mucus corpuscles, and many other forms of germinal matter, contain extremely minute particles, the nature of which has not been positively determined, as well as foreign particles which become included by the mass projecting itself around them.

The hairs from the flower of the Virginian spider-wort (*Tradescantia Virginia*) a well-known garden plant, are beautiful objects for studying the movements of the living germinal matter in the cell. The transparent matter in active movement contains many minute highly refractive particles, which enable one to detect the slightest variation of the direction in which the stream sets. The young hairs of the nettle, the cuticular cells of this and many other plants, exhibit rotation. The movement can often be seen in the young, although it may not be visible in the fully formed cells.

In pl. XXXIX, fig. 245, a branch of *Anacharis alsinastrum* is represented. It consists of long slender stems which bear a series of three narrow leaves of a pale green colour at intervals of about a quarter of an inch apart. The leaves when full grown seldom exceed a length of three-eighths of an inch. Fig. 248 shows the irregular shape and position of the cells in one of the leaves of this plant. The thickness of the central part of the leaf is composed of two layers of such cells, but at the margin only one layer exists. Fig. 246, represents one of the hollow spines or hairs at the margin of the leaf of the *Anacharis*. It appears that when the circulating corpuscles arrive near the apex of the spine where the cell wall is indurated, as shown by a brown discoloration, they do not pass quite to the apex, but are invariably hurried across the cell, as seen at *b* in the figure. The three drawings above referred to, have been taken from Mr. Wenham's paper "On the Circulation in the Leaf Cells of *Anacharis Alsinastrum*." (*Mic. Journal*, vol. III, p. 281.)

In pl. XXXIX, fig. 246, is represented a hair or spine from the stalk of *Anchusa paniculata*, one of the Boraginæ. This is also taken from a drawing by Mr. Wenham (*Mic. Journal*, vol. III, p. 49). The mode of growth and circulation of the sap-corpuscles are well shown. These accumulate and gradually become converted into the tissue of which the spine is composed. Mr. Wenham well describes this process as follows: a dense current of corpuscles travels along one wall of the spine constantly returning by the opposite side *b, b*. At *c*, where the deposition occurs, there is a considerable accumulation, and at the boundary where they are converted into the substance



Fig. 1.

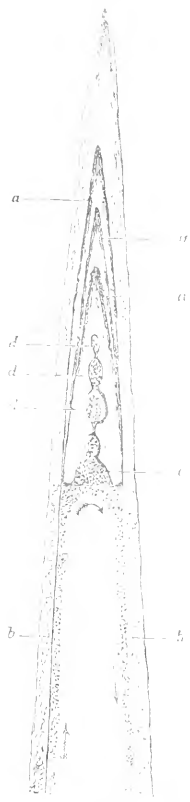


Fig. 2.



Fig. 3.

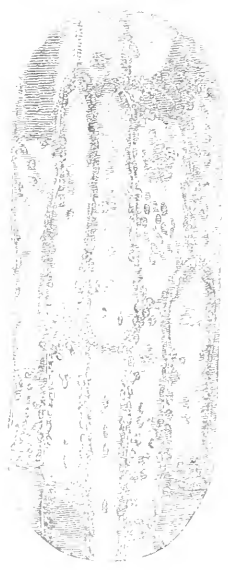


Fig. 4.

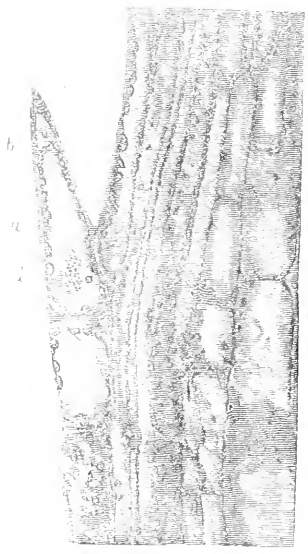


Fig. 5.



of the spine a number are seen to be adherent. Often in specimens of this plant the deposition has been so rapid that there was not sufficient time for the complete condensation of the component corpuscles. In these instances a number of them have been caught and loosely enclosed in one or more cavities, as shown at *d, d*. The walls of these containing cavities do not possess a definite outline because they are lined with corpuscles in all their different stages of transition.

The course which the current takes in the cells of vallisneria, anacharis, &c., is indicated by the arrows in fig. 247, after Dr. Branson.

Vallisneria, chara, nitella, and anacharis may be kept without difficulty in glass jars in our rooms, and tradescantia will grow in pots outside the window, and flower freely even in London. Pale or white-flowered plants should be selected for observation.

The circulation in the cells of vallisneria. and the movements of the cilia of small animalcules or ciliated cells under a high power with the new binocular of Messrs. Powell and Lealand, p. 11, once seen can never be forgotten, for the mind seems to have realised the actual state of things occurring during the life of the plant, in a manner which before was not possible.

**260. Of Preserving Vegetable Tissues permanently.**—Vegetable tissues may be preserved according to the plans already given for animal tissues. Syrup and glycerine are excellent preservative media. The germinal matter of vegetable tissues may be stained with carmine, the course of vessels and tubes may be demonstrated if filled with coloured fluids which they will imbibe by capillary attraction, especially if evaporation be promoted from the leaves.

Seaweeds which are to be preserved permanently, should be allowed to soak for some time in pure water. Small pieces may then be removed and transferred to glycerine. Some of the most beautiful vegetable preparations which I have seen have been mounted in glycerine. The mixture of gelatine and glycerine, and gum and glycerine will also be found good media for mounting many vegetable structures, and chloride of calcium forms a useful preservative fluid in many instances. Creosote fluid, carbolic acid water, very dilute spirit and water, and even simple distilled water will preserve some vegetable tissues for a great length of time. The pith of the stem of various plants, the epidermis, and many other vegetable tissues may be preserved as dry objects very satisfactorily.

**261. Of Collecting and Mounting Diatoms.**—In collecting diatoms and other organisms from pools, the pocket microscope described in p. 14, will be found very useful. A little of the sediment suspected to contain them may be placed in the animalcule cage and examined by the side of the pool. The waistcoat pocket

microscope, made by Mr. Highley, and others which preceded it, have been recommended for the same purpose, but to these there is the objection that only one very small spot can be examined, unless very low powers be employed, and it is of course a mere chance if an object happens to fall in the centre. It seems to me that every instrument, however simple, should permit the object to be moved about, at least a three-eighths of an inch in every direction. The difficulties of effecting this are not great. *See* p. 15. On collecting diatoms, *see* p. 147.

The siliceous remains of the diatomaceæ may be separated from guano and other deposits as follows: The organic matter and carbonate and phosphate may be removed by boiling in nitric acid, and the remaining deposit diffused through water and collected as before described, but I much prefer to destroy the organic matter by burning the deposit in a platinum basin, and allowing it to remain for some hours at a red heat until the black carbonaceous matter has burnt off, leaving a pure white ash. The phosphates and carbonates may be removed with dilute nitric acid, and the deposit washed. In this way the shells are not so liable to be broken as they are when the deposit is boiled for some time in strong acid.

Siliceous shells of certain diatoms are represented in pl. XL, figs. 251, 252, 255. There is much difference of opinion as to the cause of the markings in many of these. Mr. Hunt considers the dots on pleurosigma represented in fig. 252, as elevations not depressions (*Mic. Journ.* vol. III, p. 175).

The skeletons of diatoms in Bermuda earth and other deposits of a like kind may be obtained by boiling the powder for a short time in a weak solution of potash and then washing in successive portions of distilled water according to the plan described in page 85.

For the details of mounting diatoms, the reader is referred to Mr. Davies' little work on "Mounting Microscopical Specimens."

#### ON THE MOVEMENTS OF LIVING BEINGS AND UPON PURELY VITAL MOVEMENTS.

I shall now offer a few general observations upon the nature of the different kinds of movements which occur in living things, many of which have been referred to in the foregoing sections.

Hitherto many of the movements occurring in living things have been referred to the property of *contractility*, and strange to say, the very authorities who never lose an opportunity of condemning those who attribute any changes in things living to the influence of a peculiar force or power—*vitality*, consider that movements are

sufficiently explained and accounted for if they are attributed to this mystical property of *contractility*. They do not attempt to define what they mean by the word, nor do they show in what this supposed property resembles or differs from other properties of matter. They do not state whether it is peculiar to the living state or is manifested after life has ceased.

Many facts have convinced me that there is an absolute difference between *living* and *non-living* matter, and I maintain that the assertion that the *non-living* passes by gradations into the living is not justified in the present state of scientific knowledge.

Some of the most remarkable phenomena which distinguish *living* from *non-living* matter may now be observed under the microscope with the aid of the highest powers. There is no department of natural knowledge in which a greater advance is to be noticed than in this, and the facts which have been recently discovered enable us to draw a sharp and well-defined line between living things and the various forms of non-living matter, be it of simple or complex composition. If as investigation still further advances the facts already known are confirmed, and the conclusions arrived at from recent researches, supported by new observations and experiments—the operation of some agency, force, or power in living matter, distinct from every kind of physical force operating in non-living matter must be admitted, and the views at this time most popular, will have to be modified in most important particulars.

If the student studies this question carefully, he will, I think, find that confusion has arisen from the attempt to account for several essentially different kinds of movements by one property,—*contractility*. Thus any tissue which alternately becomes shortened or lengthened, gaining in one diameter what it loses in another, is said to be contractile, while on the other hand, that which moves in every conceivable direction is said to do so by virtue of the same property. It is not, however, very easy to see how two such different movements, as repeated acts of contraction and relaxation within a definite space, and the actual movement of a mass from place to place, can depend upon one and the same property. In fact, it has yet to be shown that the many different movements commonly known to occur in living things are really all of the same nature. I would arrange the movements occurring in living beings as follows:—

1. PRIMARY OR VITAL MOVEMENTS—*affecting matter in the living state only, and occurring in every direction, as seen in the amœba, white blood corpuscle, and in germinal or living matter generally.*

2. SECONDARY MOVEMENTS — the consequence of vital movements, or of other phenomena, affecting matter which is not in a living state :—

- a. *Ciliary Movements*.—Probably due to alterations in the quantity of fluid within the cell, the changes in the proportion of fluid being brought about by the action of the living or germinal matter of the cell.
- b. *Muscular Movements*.—Due to a disturbance (electrical or otherwise) in the neighbourhood of a contractile tissue—that is, a structure so disposed that its constituent particles are susceptible of certain temporary alterations in position, which alterations take place in certain definite directions only.
- c. *Molecular Movements*.—Which affect all insoluble particles, *non-living* as well as *living*, in a very minute state when suspended in a fluid not viscid.
- d. *Movements of Solid Particles suspended in Fluid in Cells, caused by Currents in the Fluid*, as the pigmentary matter in the pigment cells of the frog.—Due to the motion of the fluid as it passes into, or out of, the cell, through its permeable wall; this movement being dependent upon changes taking place external to the cell.

**262. Of the Primary or Vital Movements occurring in Living Beings.**—This kind of motion is peculiar to matter in the living state, and is not known to occur in any matter which has not been derived from matter in a living state. The movements cannot be imitated. They cease when death occurs, and having once ceased, they cannot be caused to reappear in the same particles of matter. Excellent examples of vital movements are presented in the common *amœbæ* and many other low forms of life, in the *white blood corpuscles*, in *mucus and pus corpuscles*, and less distinctly in the germinal matter (nuclei) of many tissues of the higher animals.

*Amœbæ* can always be obtained by placing a small fragment of animal matter in a wine-glass full of water and leaving it in a light part of the room for a few days. I have found it convenient to introduce a few filaments of the best cotton wool into the water. The *amœbæ* collect amongst the fibres which protect them from being crushed by the pressure of the thin glass when removed to the glass slide. An imperfect idea may be formed of the changes taking place in the form of the most minute *amœbæ* by reference to fig. XL, pl. 254.

*Mucus Corpuscles* in the mucus upon the surface of the mucous membrane of the air-passages, white blood corpuscles, and pus corpuscles exhibit similar movements, fig. 256. Changes in form



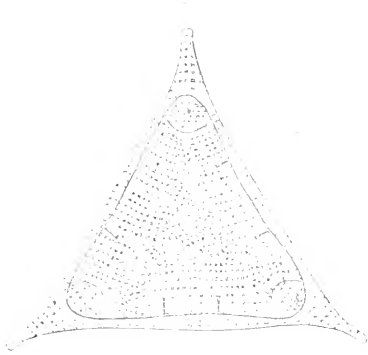


Fig. 1

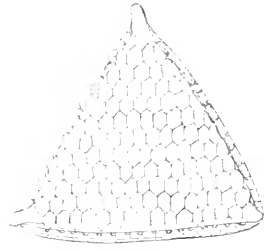
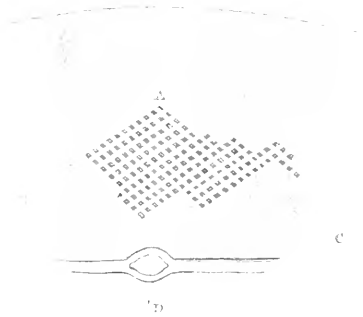


Fig. 2



c



Fig. 3



Fig. 4



may be seen to occur slowly in the germinal matter of the cornea of the frog and other animals. Soon after death a shrinking or collapse of the soft germinal matter of all cells takes place, and this alteration has led to the view that the nuclei lie embedded in spaces or vacuoles in the tissues. During life, and especially in the early and more active period of growth, the germinal or living matter is *continuous* with the tissue, and the shrinking and alteration in question are due to changes which immediately follow the death of this living matter.

The germinal matter entering into the formation of ova is the seat of active vital movements which may be studied without difficulty. In the ova of the common water snail (*limnæus stagnalis*) complete rotation occurs, and the embryo from an early period is covered with cilia. Changes in form may be observed in the ova of amphibious reptiles, particularly the frog and newt. Those of the pike, stickleback, and many osseous fishes are particularly favourable for observation (Ransom). The stickleback can be easily kept by the microscopist in an aquarium. They sometimes breed in confinement, and the sort of nest which is made for the protection of the young and guarded by the male, is an object of great interest.

The movements in germinal matter of the higher animals (mucus, pus) can be distinctly seen with a twelfth of an inch object-glass, but it is often necessary to examine one particular corpuscle very attentively for half a minute or more. In some cases the changes in form are so slow that the observer who looks at the object for the first time cannot satisfy himself of the actual occurrence of the movement at all. It is absolutely useless to attempt observations of this kind in an off-hand, slap-dash, self-asserting manner. Those who desire to have the delight of pondering over such changes will gladly find the leisure to observe the facts. This is just one of those phenomena which, having been well seen once can generally be detected afterwards without much difficulty. Under the sixteenth, twenty-fifth, or fiftieth, the alteration in form can be seen very distinctly, and there are few things more wonderful, or which will furnish more interesting matter for careful thought and for valuable and useful speculation.

The movements I have described as *vital movements* I regard as *primary*, and think that the power of movement exists in connection with the matter of which each small portion of the moving mass is composed. It may be to some minds unsatisfactory to attribute the phenomenon to the influence of a power of the nature of which nothing is known, but it is surely better to do this for the present, than to assert that these movements are due to physical force, when

they cannot be explained by known laws. Any unprejudiced person who thoroughly studies the movements and carefully thinks over the facts of the case, will, I think, find himself compelled to admit that they cannot be accounted for in the present state of our knowledge, without assuming the existence of *vital power*.

**263. Of the Secondary Movements occurring in Living Beings.**—Ciliary movement has been already referred to in p. 161, and muscular contraction in p. 160.

*Of Molecular Movements.*—When any solid matter in an exceedingly minute state of division is suspended in a limpid fluid, every one of the minute particles is seen to be in a state of active motion or vibration in the neighbourhood of other particles. The cause of these molecular movements has not yet been satisfactorily explained, and they have often been mistaken for *vital movements*. If some *bacteria* developed in any decomposing water be exposed to a temperature of 200° they are destroyed, but although quite dead, *molecular movements* still occur. If however, the movements of the dead particles be compared with those of living bacteria, a great difference will be discerned. Probably many movements of particles occurring in cavities in crystals are of the same nature. See p. 178.

*Movements of Granules within Cells.*—The movement of insoluble particles from one part of a cell to another, as occurs in the radiating pigment-cells of batrachia (frog, toad, and newt), is probably due to alterations in the direction of the flow of fluid in the cells,—*from* the cavity of the cell *towards* the tissues, or *from* the surrounding tissue *into* the cell. If the capillaries were fully distended, fluid would permeate their walls and would pass into the cavity of the cells, in which case the insoluble particles would gradually become diffused and would pass into all parts of the cell; while, on the other hand, if the capillaries were reduced in diameter, and the lateral pressure upon their walls diminished, there would be, as is well known, a tendency for the fluid in the surrounding tissue to flow towards the vessels and pass into their interior. In this case the quantity of fluid in the cells would become gradually reduced, and the insoluble particles would become aggregated together, and would collect in those situations where there was most space, as in the central part of the cell around the nucleus. Moreover, in the last case, the flow of fluid, which constantly sets towards the nucleus, would be instrumental in drawing the particles in this same direction, while if the cell contained a considerable proportion of fluid, the currents would pass between the particles without moving them. Evaporation, as it occurs after death, causes concentration of the insoluble particles towards the centre of the cells.

On the other hand, the changes in these pigment-cells of the frog have been considered by Professor Lister to be due to *vital actions*, and he agrees with Wittich and others who maintain they are under the immediate control of the nervous system. *Indirectly*, no doubt, they are, but I do not think that any experiments have proved satisfactorily that the nerves exert any *direct* influence upon the movements of the particles in these cells. It is well known that the nerves govern the calibre of the vessels, and thus influence the amount of fluid in the surrounding tissues, and in this indirect manner nerves may be said to affect the movements of the particles in the cells. The reader will find a full account of Professor Lister's experiments, and the arguments deduced from them, in his paper "On the Cutaneous Pigmentary System of the Frog," published in the Philosophical Transactions for 1858.

**264. Of Growth and Multiplication.**—Almost inseparable from the consideration of the nature of the movements occurring in living things, is the study of operations by which particles are added to and often lifted above other particles in the process of *growth*,—a universal property of things that live. The observer who aims at studying the remarkable and highly interesting phenomena of germination, growth, and multiplication of cells or elementary parts in the tissues and organs of man in health and disease, will find it absolutely necessary to investigate these processes in the simplest living beings where they occur under less complex conditions. He must exercise the utmost caution in drawing inferences from what he does see or rather thinks that he sees, and he must always bear in mind that great and irreconcilable differences of opinion exist among even distinguished observers with regard to the general nature of the changes which takes place when, for example, a spore of common mildew germinates, or an insignificant bacterium gives rise to new bacteria. How then is it likely that the mode of growth, origin, and multiplication of some of the highly complex structures formed in man, especially in the course of disease, can be described with correctness or fully explained to the student?

It has been stated over and over again that living bacteria *originate* in decomposing matters, and one who has recently written on the subject thinks that he has seen the fibrillæ of muscle resolve themselves into these living bodies! It is always necessary to be on our guard against the acceptance of fallacious observations of this kind. Those who have had much experience in the manufacture of pseudo-bacteria, could produce a number of objects and advance facts and arguments which would probably fully convince any inexperienced person that there was abundant evidence to prove

that bacteria were but the modified particles of certain tissues, although the evidence really points the other way. Perfect looking bacteria may be produced readily enough by gently warming over a spirit-lamp a little blood placed on a glass slide and covered with thin glass. From the red blood corpuscles under these circumstances numerous very narrow-jointed filamentous processes are seen to project, and from their constant vibration and molecular movements these might be easily mistaken for living bodies, pl. XLI, figs. 260, 262. Sometimes they become detached and move about in a manner much resembling certain forms of bacteria. At the same time any one familiar with investigations of this kind would be deceived neither by the general appearance nor by the movements of these bodies. Living bacteria, like other living things, come from germs formed by pre-existing living things like themselves.

The student will learn many most important facts by watching the germination of the common mildew, and studying the different appearances of the plant when developed under different circumstances, pl. XLI. It is exceedingly instructive to watch the growth of the spongioles of a young plant (mustard seed, wheat, mignonette, or better, any much smaller seed), as they grow under the thin glass. Fluid may be constantly supplied according to the plan described in page 67.

By dint of a little really careful observation the student will soon learn to distinguish purely vital phenomena from mere physical and chemical changes, and will be able to answer the arbitrary dicta of those who persist in looking upon phenomena which have nothing whatever in common, as of the same nature and due to the same cause. Would not any other conclusion have afforded support to the views they have adopted concerning what has been termed unity?

#### OF THE EXAMINATION OF ROCKS, CRYSTALS, AND FOSSILS,\*

**265. Of the Anatomy of Crystals.**—In the first place it is most important that an observer should make himself acquainted with what may be called the anatomy of crystals. Much might be said on this subject, and much remains to be learned. A crystal in its most perfect state is bounded by definite and perfect planes, and has an uniform and simple structure throughout, as shown by its cleavage or by its optical characters; but, though the external form may be very simple and perfect, its internal structure may be far from

\* For the observations upon the examination of rocks and crystals, including §§ 265, 266, 267, 268, and 269, I am indebted to the kindness of my friend Mr. H. C. Sorby, F.R.S.







simple. Thin plates or large segments may occur, the material of which is not in the same crystalline position as the rest, but inclined at different angles, according to the laws of twin crystals; and in some cases this gives rise to very remarkable characters, seen to great advantage in some of the constituents of meteorites. On the contrary all perfect crystalline planes may be absent, and yet the ultimate structure may be that of a simple and perfect crystal, as shown by cleavage, or by the action of polarized light; and therefore it becomes necessary to understand what terms should be employed to express these facts. Shall we use the term *a* crystal to signify a body bounded by definite planes, which may have a very composite internal structure, or to signify a body of perfectly simple and uniform molecular constitution, which does not happen to have perfect bounding planes? In studying the structure of rocks it appears to me far better to use the term *a* crystal to signify the simplicity of ultimate molecular constitution, and to express the character of the external form by saying whether it is bounded by crystalline planes or by irregular surfaces, independent of the crystalline structure.

If we use this phraseology we may say that each detached plate of the echinodermata is *one* crystal, being as if it were made out of one simple crystal of calcite cut into the form and hollowed out into all the complicated structure characteristic of that kind of shell; and as an example of the very opposite fact, I may refer to certain crystals of native phosphate of lime, which have the external planes characteristic of that mineral, and yet are made up of a vast number of much smaller crystals, in no way related to the external form, and not bounded by crystalline planes. Such distinctions are amongst the most important in studying the microscopical structure of rocks, and from such facts the physical history of a rock may be deduced.

**266. Of the use of Polarised Light.**—In applying these principles it is requisite to understand some of the leading facts connected with polarised light. It must not be used merely to show structure, or, as is too often the case, merely to show pretty colours, but as the most searching means of learning the nature and molecular constitutions of the substances under examination. The action of crystals on polarised light as applied to the microscope is due to their double refraction, which depolarises the polarised beam, and gives rise to colours by interference, if the crystal be not too thick in proportion to the intensity of the power of double refraction in the line of vision. This varies much according to the position in which the crystal is cut, and, therefore, in a section of a rock different crystals of the same mineral may give very different results; but still we may

often form a good general opinion on the intensity, and may thus distinguish different minerals whose intensity of action varies considerably. But besides this, the intensity, but not the character of the depolarised light varies according to the position of the crystal in relation to the plane of polarisation of the light. There are two axes at right angles to each other, and when either of them is parallel to the plane of polarisation, the crystal has no depolarising action, and if the polarising and analysing prism are crossed, it looks black. On rotating either the crystal or the plane of polarisation, the intensity of depolarising action gradually increases, until the axes are inclined to  $45^\circ$ , and then gradually diminishes till the other axis is in the plane of polarisation. If, therefore, we are examining any transparent body, and find that this takes place uniformly over the whole, we know that the whole has one simple crystalline structure; whereas, if it appears as it were to break up into detached parts, each of which changes independently, we know that it is made up of a number of separate crystalline portions, either related as twins, or quite independent of each other, as other facts may indicate. By using a plate of selenite of suitable thickness, we may also ascertain in what directions the crystal raises and depresses the tint of colour given by the selenite, and can thus determine the position of the principal axis of the crystal.

As an excellent illustration of the use of these principles, I may refer to the structure of pseudomorphs. We may often see in sections of rocks crystals which are much broken up either by mechanical violence or by incipient decomposition, and it might often be extremely difficult or impossible to distinguish them from other cases where the external form is also that of a perfect crystal, and yet the material completely changed. In the former case polarised light will often show at once that all the different portions are in the same crystalline position, and related to the external form, but in the latter are arranged promiscuously, independent of the external form, or related to it as products of an alteration which extended inwardly from the outer surface or from irregular cracks. Occasionally most important theoretical conclusions depend on such a structure, and it may be almost conclusive proof of the metamorphism of masses of rock when other evidence almost fails.

Then again we must examine and bear in mind any definite order that may be found to occur in the arrangement of a number of crystals, since that may indicate important differences. This depends on the fact that crystals have a tendency to form with particular faces perpendicular or parallel to the surface on which they grow, depending partly on the nature of the substance, and partly on the secondary

form which may be produced in particular circumstances. Such facts may show for example that some round bodies, like oolitic grains, have been formed by the external growth of crystals radiating from a central nucleus, whilst others, like those so common in meteorites, were formed in an entirely different manner, and have the structure of round bodies which crystallised afterwards.\*

**267. Crystals of one Mineral enclosed in another.**—The enclosure of crystals of one mineral inside another presents us with a long series of interesting facts, described in a work specially devoted to that subject.† Any one who has not examined the microscopical structure of some rocks, would hardly believe the extent to which this occurs. The minerals in erupted lavas are often full of minute crystals, and it is easy to understand why chemical analyses should frequently give such anomalous results. Care must sometimes be taken not to confound such included minerals with cavities, and by using polarised light we generally distinguish them, though it must be admitted that transparent crystals having no double refraction might look very much like cavities *filled* with some liquid. The most satisfactory proof of their being cavities is the formation of a bubble when the temperature is reduced, but in other cases we may observe whether the form is that of an independent minute crystal, or related to the shape of the larger crystal, as is the case with cavities.

**268. Of the Cavities in Crystals.**—The study of these cavities constitutes one of the most important branches of our subject, since by means of them we may often learn under what conditions the rock was formed, as I have shown in a paper published some years ago.‡ I think that I cannot do better than give the short abstract printed at the time.

“In this paper the author showed, that, when artificial crystals are examined with the microscope, it is seen that they have often caught up and enclosed within their solid substance, portions of the material surrounding them at the time when they were being formed. Thus, if they are produced by sublimation, small portions of air or vapour are caught up, so as to form apparently empty cavities; or, if they are deposited from solution in water, small quantities of water are enclosed, so as to form *fluid-cavities*. In a similar manner, if crystals are formed from a state of igneous fusion, crystallising out from a fused-stone solvent, portions of this fused stone become entangled, which, on cooling, remain in a glassy condition, or

\* On measuring the angles of crystals, see part III.

† Söchting. *Einschlüsse von Mineralen*. Freiberg, 1860.

‡ *Quart. Jour. Geol. Soc.*, vol. XIV, p. 453.

become stony, so as to produce what may be called *glass-* or *stone-cavities*. All these kinds of cavities can readily be seen with suitable magnifying powers, and distinguished from each other by various definite peculiarities.

From these and other facts, the following conclusions were deduced:—

1. Crystals containing only cavities with water were formed from solution.
2. Crystals containing only stone- or glass-cavities were formed from a state of igneous fusion.
3. Crystals containing both water- and stone- or glass-cavities were formed, under great pressure, by the combined influence of highly heated water and melted rock.
4. That the relative amount of water present in the cavities may, in some cases, be employed to deduce the temperature at which the crystals were formed, since the accompanying vacuity is due to the contraction of the fluid on cooling.
5. Crystals containing only empty cavities were formed by sublimation, unless the cavities are fluid-cavities that have lost their fluid, or are bubbles of gas given off from a substance which was fused.
6. Crystals containing few cavities were formed slowly, in comparison with those of the same material that contain many.
7. Crystals that contain no cavities were formed very slowly, or by the cooling from fusion of a pure, homogeneous substance."

Independent of their connection with the origin of rocks, these fluid-cavities are very interesting as microscopical objects, since the small bubbles which they contain exhibit spontaneous molecular movement to great advantage. As illustrations of such cavities, the reader is referred to figs. 263, 264, in pl. XLII. In fig. 263 is one enclosed in a crystal of nepheline, from one of the ejected blocks of Monte Somma, and shows two different kinds of included crystals, water—or rather a concentrated saline solution—and a spherical bubble. Fig. 264 is from the quartz of granite, with a very small bubble, which moves about freely in the water filling the cavity. It is only when such bubbles are very minute that their movement is decided, but when, for example, about  $\frac{1}{200000}$ th inch in diameter, they frequently as it were swim about in the liquid, like minute animalcules. Brown, in a paper printed in 1827, showed that minute solid or even liquid particles contained in another liquid possess a natural molecular movement, quite independent of any currents, and this motion of the bubbles in fluid-cavities appears to me to be in all respects the same, only that it is the movement of a gaseous globule.

As far as I am aware no satisfactory explanation has been given of this curious phenomenon, and I can only suggest that it is in some way related to those molecular movements on which sensible heat appears to depend.

**269. On Making Sections of Rocks and Crystals.**—Comparatively little can be learned of the structure of rocks and minerals from the examination of fractured surfaces by reflected light. Flat polished surfaces show very much more, but nearly all the important facts can only be observed by examining thin sections by transmitted light. What is really requisite is to have portions sufficiently thin, flat, and smooth to transmit light. In some cases fragments of clear minerals may be broken thin and flat enough to show certain facts very well, when mounted in Canada balsam; and in this manner we may easily study the fluid-cavities in quartz, or the structure of such rocks as obsidian and pitch-stone. In many cases, however, we must have recourse to carefully prepared thin sections. The details of the method of preparing these must necessarily vary according to the mechanical means at the disposal of each person, and much time may be saved by the use of machinery. I shall therefore give such a general account as may be used by any one who has not machinery at command, premising that it will be easy to modify it in detail, according to the facilities which each may possess for employing more expeditious methods.

In collecting specimens for examination, I find it convenient to break off portions from the rock as flat and thin as possible, so that they may be ground down at once; for otherwise it may be requisite to saw off portions with a lapidary's wheel, or by means of a straight toothless saw of sheet-iron with emery. Having made the specimen of a convenient size and form, with one side flat, this must be ground down perfectly level and dressed off very smooth. I usually avoid using any polishing powder, since, if it were to work into cracks or cavities, it would be far more objectionable than any slight want of polish. If we attempt to grind down the surface on such a stone as should be used to finish off, very much time would be lost, and it is therefore best to use a series of stones of increasing fineness. I have generally used first fine emery on a plate of iron or zinc, then a kind of stone known by marble workers as "Congleton;" after that a soft piece of Water-of-Ayr stone, and finally finish off on a very hard and fine-grained piece of the same kind. However, since it may be difficult to procure such stones, a flat slab of fine-grained marble, or different kinds of slate may be used. What is wanted is to finish off the surface so as to be free from scratches and almost polished, with the hardest and the softest portions ground down to

the same level. If not dressed smooth by slow grinding, the hard portions will stand out in relief; and when the section is finished, the soft parts may be all ground away before the hard are sufficiently thin, and the structure of the rock may be quite misunderstood. Having duly prepared one flat surface, it should be fastened down on a piece of glass with Canada balsam. This should be kept hot until it is so hard as to be just brittle when cold. I find it best to remove, time after time, a small piece, until it has become so hard that when cold, it can be rubbed to powder between the thumb and finger. The piece of stone should be made hot, but no hotter than needful, so that liquid may not be expelled from the fluid-cavities, and balsam should be spread over the flat surface, and kept hot for a while; which penetrates into the softer parts and hardens them. Before fixing the specimen on the glass, it is well to remove this balsam, and fasten it down by that on the glass. I find it much the best to use square pieces of glass. The usual 3-inch by 1 glasses are very unsuitable for the purpose; since they are much too long in one direction, and too short in the other. I use glasses  $1\frac{1}{8}$  inch square, and generally make sections about 1 inch square, which is a very suitable size. Since the section ought not to be removed from the glass, care should be taken in grinding down not to scratch the glass. This may be avoided by fastening small bits of sheet zinc at each corner with balsam, and grinding the stone with emery until they all come flat down on the plate. The stone is then equally thin all over; and having removed the bits of zinc it must be further ground down on the stones until of the proper thickness, and the upper surface finished off in the manner already described. The thickness must depend very much on the nature of the rock. If coarse-grained and composed of comparatively transparent minerals,  $\frac{1}{1000}$ th of an inch may not be too thick, whereas some very fine grained and opaque rocks should be not above  $\frac{1}{1000}$ th of an inch. Of course it is requisite so to grind them down as not to break up or disturb the different constituents; and, since some parts may be very hard and some very soft, it is impossible to prepare perfect sections unless they are slowly ground down on a fine grained stone, which may gradually wear away the hardest parts without injuring the softest. After having finished the section I find it often better to keep it some time before I mount over it a thin glass cover, in order that the balsam may become quite hard. I then melt some balsam at a gentle heat on a thin glass cover of proper size, and just before I place it on, I wet the surface of the section with a drop of turpentine, which soaks into the pores so as to make it more transparent, and renders it much easier to fasten down the glass without any bubbles. This must be

done at a very gentle heat, so as not to cause the section to break up by melting the balsam which holds it fast to the glass plate.

Sections of very soft rocks, which would easily break up in water, may be prepared in the same manner by hardening them with balsam. They should be first soaked with turpentine, and then with soft balsam, and kept hot until quite hard.

We may modify the above plan with advantage in preparing sections of such hard minerals as quartz. If ground down with emery and water, deep scratches are produced, and it takes a long time to remove them by means of the softer stones. This may be avoided by using fine emery paper, held flat on a piece of plate glass. After grinding down to nearly the proper thickness with emery and water, common English flour-emery paper may be used, which soon removes the deep scratches; and afterwards the surface may be almost polished by using the finest French emery paper employed in preparing steel plates for engraving; a perfect polish can then be easily given by means of rouge on parchment. Crystals of salts soluble in water may also be ground down and dressed smooth on emery paper, and finally polished with rouge in the same manner; but in many cases they may be examined without this preparation, and may be fastened on glass with balsam. Some are decomposed by contact with balsam, and must be kept dry in small covered cells; others may be mounted in a concentrated solution of the same salt, when it is desirable to retain the liquid enclosed in the fluid-cavities; and when very small they may be mounted in Canada balsam, or, if that be objectionable, in castor oil.

Sometimes the structure of a rock or other mineral substance may be studied to great advantage by grinding it to a suitable shape, moderately thick and flat, fixing one side to glass with balsam, and acting on the other with a dilute acid. If one part is soluble and the other not acted on, some valuable facts may be learned. As an example I refer to the *Eozoon Canadense*, which has lately attracted so much attention. One part consists of carbonate of lime, and the other of siliceous minerals insoluble in diluted acid; and when the former is dissolved a most beautiful and minute structure may be seen, which appears to be due to minute tubes and other open spaces filled with the insoluble minerals.

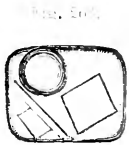
**270. Of the Microscopical Structure of Iron and Steel.**—The microscopical structure of iron and steel is best shown by polished surfaces slightly acted on by very dilute nitric acid. The section should be cut in the required direction by means of a saw, and ground or filed down to a convenient thickness, and fixed to a

piece of glass. The upper surface should then be filed level, and dressed with coarser and finer emery paper, and afterwards ground smooth with a bit of a soft Water-of-Ayr stone about  $\frac{1}{4}$ -inch square. Every trace of roughness should then be removed by means of rouge and water on cloth; for unless the surface be extremely well polished the structure of some kinds of iron cannot be seen. It must not be that sort of polish which merely gives a bright reflection, but one which may show all the irregularities of the material, and is as far removed as possible from a burnished surface. All trace of the rouge should be washed off, and care used not to touch the surface with the fingers, which is then acted on with extremely dilute nitric acid. If the action be allowed to proceed too far, the most important points in the structure may be entirely obliterated; and therefore it is well to take the section out of the solution and examine it under water in a glass trough, and again act on it with acid, time after time, until the structure is seen to the greatest advantage. The section must then be well washed and quickly dried by wiping the surface with a handkerchief; and after slightly rubbing it on soft wash-leather, a thin glass cover must be mounted over it with Canada balsam.

Of course such sections must be examined by reflected light. For this purpose no illuminator is better than the parabolic reflectors supplied by Messrs. Beck, which were in fact first made for me, for that special purpose. I afterwards added another small reflector, inclined at an angle of  $45^\circ$ , attached to a moveable arm, so that we may see an object by direct reflection. The general construction will be seen from fig. 265, pl. XLII, copied from Mr. Richard Beck's paper in the Transactions of the Microscopical Society (vol. XIII, p. 117).

The small reflector is seen at *m*, with a semi-cylindrical tube *x*, to shut off the light reflected by the parabola. When the latter is used the small reflector is turned away by means of the milled head *w*, into the position indicated by the dotted lines. The difference between the two illuminations will be seen from figs. 266 and 267. When the parabola is used, light passing from *d* is reflected from *f*, fig. 266, and if the object *b* has a polished surface, is again reflected to *e*, quite outside the object-glass *a*, so that a polished surface appears black, whilst at the same time a rough surface appears white or coloured by diffused reflection. When, however, the small reflector *g*, fig. 267, is half over the object-glass, the light is reflected through the other half of the lens *c*, in such a manner that a polished surface appears bright, and a rough surface comparatively dark. We can thus distinguish at once the difference

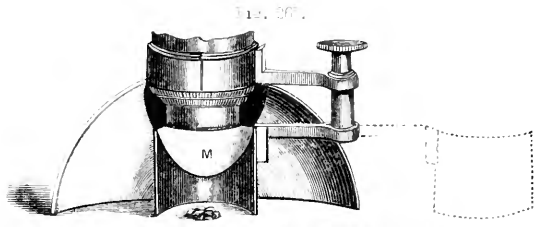




Crystal of nepheline  
observed in a field  
cross and crystals  
p. 178.



Crystal from the  
point of fracture  
with a small  
cavity p. 178.



A spherical reflector of silver, with the lens *M* p. 177.

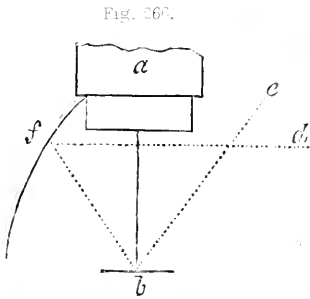


Fig. 266.

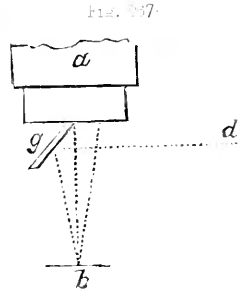
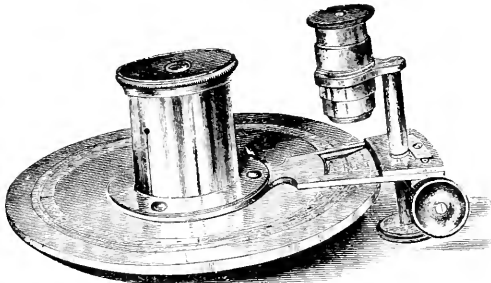


Fig. 267.

Fig. 266 illustrates the different methods of illumination by Leek's parallel red cross. Fig. 267 illustrates the method of illumination by Leek's parallel red cross. *a* is a glass plate, *b* an object, *d* rays of light, *f* rays of the parallel reflector at which the light is reflected upon the object, *g* flat mirror which reflects the light parallel to the object from which it reflects at a point within the aperture of the object glass p. 177.

Fig. 268.



Geeson's step-angle goniometer for measuring the angles of crystals p. 178.



Fig. 269.

Crystals of cholesterine consisting of a variety of  
forms some being perfectly flat. x 100 p. 178.

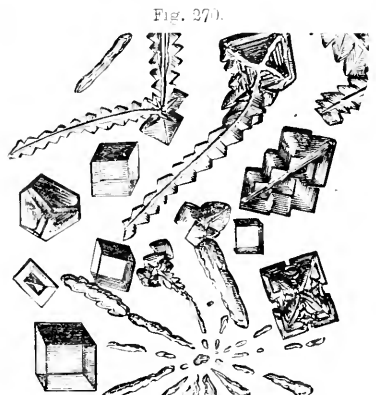


Fig. 270.

Crystals of chlorite of various sizes and  
forms some being perfectly flat. x 100 p. 178.



between black slag and that very hard constituent of some kinds of steel, which remains so bright and polished after having been acted on by cold diluted acids, as to look quite as black as the slag by ordinary illumination. In fact, I may say that in studying irons and steel such an illuminator is indispensable.

**270\*.** **On Measuring the Angles of Crystals—Goniometer.**—I have already adverted to the principal methods of measuring objects, but have not discussed the mode of ascertaining the value of the angles of microscopic crystals in the microscope. The simplest instrument for this purpose is one which was arranged many years ago by Schmidt and known as *Schmidt's goniometer*. It consists of a cobweb stretched across the field of an eye-piece, and capable of being moved by an arm which passes round an accurately graduated arc. The cobweb line is placed parallel to one face of the crystal, the circle being moved round until the bar stands at zero. The latter is then made to rotate until the cobweb is brought parallel with another face. The number of degrees through which the bar has passed marks the angle of the crystal. It is absolutely necessary that in taking this measurement the crystal should be perfectly flat, for otherwise a false angle will be obtained, pl. XLII, figs. 269, 270. Dr. Leeson has proposed a more perfect arrangement for measuring the angles of small crystals. Pl. XLII, fig. 268.

Those who devote themselves to mineralogical or crystallographic investigations require special appliances for determining the optical properties of refracting bodies and observing the process of crystallisation in saline solutions, &c. Dr. Lawrence Smith, of Louisville, U.S., designed an instrument specially for such purposes, which he called the "INVERTED MICROSCOPE" (*American Journal of Science*, second series, vol. XIV, 1852). The object-glass was placed below the mica, quartz, or glass plate that carried the solution to be crystallised, with the view of protecting the lenses from the corrosive action of acid vapours, especially that of hydro-fluoric acid, which also interfere with the definition of objects under examination. This arrangement was improved upon and more fully developed in its applications by Mr. Highley, who described the "Mineralogists Microscope," figured in pl. XLIII, in the *Quarterly Journal of Microscopical Science*, vol. IV, p. 281. It may thus be briefly described with the aid of the figs. 271 and 272. The general distribution of parts is shown in the first figure, when the instrument is arranged for ordinary microscopical observations. Fig. 272 displays the same in section arranged for optical investigations, and for measuring the optic axis in crystals.

On a central pivot screwed into a solid circular base rotates a

plate that carries the body, prism box P, object-glass, and fine adjustment A : to the side of the base is fixed a square bar G, that carries the principal stage with its coarse adjustment, and the secondary stage into which fits the diaphragm, polarising bundle B, selenite plates, &c. A tube screws into the top of bar G, on which slides the mirror. The body slides into a socket attached to the prism box. Within the draw tube are fittings to receive glass tubes for examining with a Leeson's goniometer and minute stop, the amount of rotation in liquids that exhibit circular polarisation.

The prism P, that reflects the image of the object up the axis of the body at a convenient angle for observation, is contained in a solid brass box, on the upper surface of which are screwed the tubes and fine adjustment A that carry the object-glass, and one side is removeable to allow of the prism being readily taken out and cleaned.

A semicircular arm works up and down the upright bar G, by means of a rack and pinion R, and supports the circular stage S, which for ordinary work is kept in a horizontal position by means of the clamp nut N. The stage has a projecting ring, within which a graduated plate rotates when optical examinations have to be made : but which is ordinarily fitted with a plain metal plate that rises flush with the top of the axes of the stage. In this instrument the object has to be placed with the glass cover downwards.

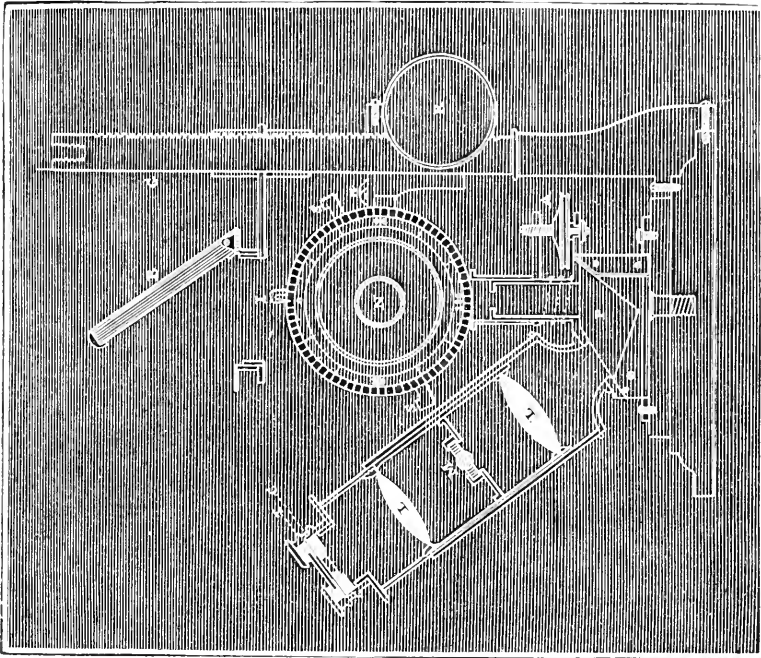
A short body replaces the ordinary one for optical examinations ; this is fitted with a tourmaline T, and a cell for a plate of calc spar C, when the instrument is to be used as a modification of Professor Kobell's stauroscope for determining crystal systems ; and two lenses L L with a Jackson's micrometer M, when the instrument is required for the determination of the optic axis on the principle of Soleil's instrument.

For such investigations consult the Mineralogical Works of Dufrenoy, Delafosse, Descloizeaux, and Grailich.

At the present date Mr. Highley arranges all apparatus required for investigating mineralogical or crystallographic optics, including Norremberg's recent system of lenses, so as to be adaptable to most of the ordinary forms of microscope, and prefers using a cheap form of microscope with a prism having a single reflecting surface instead of two, as in the instrument figured in pl. XLIII, for observing crystallisations or corrosive or fuming objects.

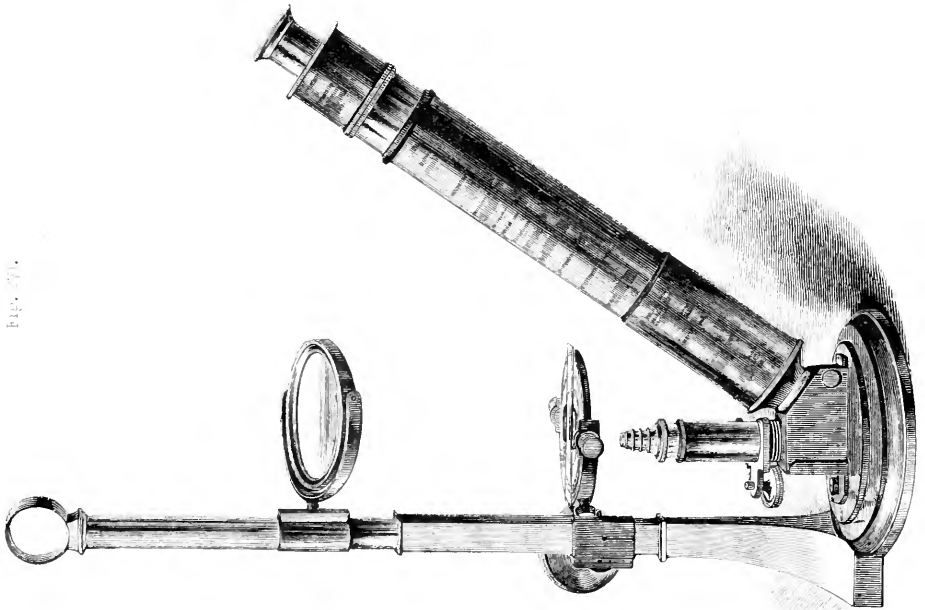
**271. Of Preparing Fossils for Microscopical Examination.**—Different methods of preparation are required in examining the various fossils. Many kinds of fossil bone and some forms of teeth may be prepared according to the directions given in p. 82. In cases in

Fig. 97.



A. Lens. B. Secondary stage. C. Central stem or bar on which the main secondary stage is pivoted. D. Lens. E. Lens. F. Lens. G. Lens. H. Lens. I. Lens. J. Lens. K. Lens. L. Lens. M. Lens. N. Lens. O. Lens. P. Lens. Q. Lens. R. Lens. S. Lens.

Fig. 98.



H. Invert of microscope of Dr. L. Smith, of Boston Coll. U.S. p. 56.



which silica is present the section must be made as described in p. 179. If very brittle, one surface of a thick section may be ground and polished. This is then to be cemented to the glass slide with Canada balsam, and the opposite side ground until sufficiently thin, when it may be polished in the usual way, wetted with balsam, and covered with thin glass.

Thin chips of flint and other siliceous structures often answer as well as thin sections ground and polished with a great expenditure of labour.

The structure of many fossils, the mineral matter of which consists of carbonates or phosphates, may be investigated after the salts have been dissolved out, or only softened by being soaked for some time in hydrochloric acid diluted with water or mixed with glycerine. Dr. Carpenter gives the following directions for demonstrating the structure of *Eozoon Canadense*:—“The minute structure of *Eozoon* may be determined by the microscopic examination either of thin transparent sections, or of portions which have been subjected to the action of dilute acids, so as to remove the calcareous shell, leaving only the internal casts, or models, in silex, of the chambers and other cavities, originally occupied by the substance of one animal.”

**272. Of Preparing Specimens of Coal for Microscopical Examination.**—Coal is one of the most difficult substances to cut into thin sections. It is so opaque that no structure can be discerned unless it is ground exceedingly thin, and so brittle that it often breaks up in the operation of grinding. It is said that coal may be softened by maceration in a solution of carbonate of potash, when sections may be cut with a razor. The sections are partially decolorised by being gently heated for a short time in strong nitric acid. When of a brown colour they are to be washed in cold water and preserved in glycerine (*Micrographic Dictionary*). Cannel coal being less brittle than ordinary coal is more easily prepared.

THE WORK TABLE—OF MAKING AND RECORDING OBSERVATIONS—  
FALLACIES TO BE GUARDED AGAINST.

**273. The Work Table.**—Although beautiful work tables furnished with every possible requirement have been designed for microscopists, I think the student will find that an ordinary table which is firm and steady is all that he really requires. It should, however, be well made and provided with a few drawers in which the student can place partitions for himself and arrange according to his

instruments and apparatus. The microscope should be always ready for use and should stand on the table covered with a glass shade to protect it from the dust. This is far more convenient than the plan of keeping the instrument in its case, and going through the process of adapting the glasses, &c., and then removing them again, every time the instrument is required.

The object-glasses, eye-pieces, condensers, and other apparatus may be placed in a little cupboard provided with shelves and having a glass door with lock and key.

Knives and scissars can be kept in a shallow box having a glass cover. Drawing instruments in a second, thin glass and glass slides with watch glasses, or little saucers, in a third. These should all be properly partitioned and may be kept on the table. A glass of clean water should always stand on the table, and pipettes, stirring rods and camel's hair brushes, all perfectly clean, should be provided. The injecting apparatus and instruments which are only required occasionally may be kept in the table drawers. A portfolio or pamphlet box is necessary for keeping drawing paper, cardboard, tracing and retracing paper, scales for measuring, &c. All things really necessary for ordinary microscopic work may be obtained for two or three pounds, but it is easy of course to spend fifty pounds or more upon a microscope table and apparatus. I have myself always made use of an ordinary good strong library table fitted with drawers underneath, and I think it would have been difficult to contrive anything upon the whole more convenient or better adapted for work. The microscope stands on the table always ready for use under a bell jar, and the lamp, fig. 48, pl. XL, with scissars, knives, needles, and other tools in frequent use close by.

**274. Of Keeping Preparations in the Cabinet.**—Preparations mounted in the dry way, or in Canada balsam, may be kept upright, arranged in grooves, but all preparations mounted in fluid must be allowed to lie perfectly flat, otherwise there will be great danger of leakage. Cabinets holding several hundred specimens arranged in this manner may now be purchased of the microscope makers for a very small sum, but if the observer is only provided with deep drawers, they may be made available for the purpose, by having a number of shallow trays of mill board made to fit them accurately. Each preparation should be named as soon as it is put up, and it is convenient to keep a number of small gummed labels away at hand for this purpose. Once or twice in the year a new layer of Brunswick black should be applied, and the specimens carefully examined to see that no leakage has occurred. The cases now generally sold are, I think, preferable to cabinets, and of the cases I have seen



the most convenient are those suggested by Mr. Piper, and sold by Mr. Highley, Mr. Collins, and others. They are made for two, three, six, and twelve dozen specimens, costing respectively 2s. 6d., 3s. 6d., 5s. 6d., and 10s. Cases made of deal are also arranged on the same plan.

**275. Of making Observations upon Specimens in the Microscope.**

—If, upon examination, a specimen does not appear to the observer to justify the description or delineation which some observer has given of a similar structure, he must not too hastily infer that the author has been recording the results of his imagination rather than observed facts. The conclusions which have been arrived at are probably the result of a very long and patient investigation, deduced from examining specimens, perhaps, many under very different circumstances, after the application, perhaps, of various chemical reagents, and after ascertaining the effect of different refractive media. From the remarks already made, some idea may be formed of the many different operations which are necessary to demonstrate conclusively the anatomy of a single tissue. The observer must not, therefore, be too hasty in deciding upon the nature of an object in the microscope; neither must he infer that what he has not been able to see does not therefore exist. His eye and mind will require much careful education before he can hope to be able to form a correct opinion.

Some, however, fall into an error of another kind, but not less detrimental to forming habits of correct observation. Led away by their imagination, they think they see everything which has been delineated, or which they have heard described; the observations of authors appear to be confirmed, and, in expressions closely resembling the original, while in truth their own assertions are merely reiterated in favour of their own doctrines, without any real confirmation of the accuracy of their views being advanced. In this manner errors have been confirmed and propagated to an extent almost incredible, and it may require years of laborious investigation to overthrow statements which never resulted from actual observation, which were erroneous from the first and ought in fact never to have been received. Sometimes a mere idea, taking for its ingenuity and novelty, but having no foundation in fact, is seized upon by a number of persons, and supported by so many assertions wrongly called observations, that it is soon received as true, and is perhaps believed in for years, until at last some one reinvestigates the whole question, and at length demonstrates the absurdity of the doctrine.

*Of the Importance of Making Sketches.*—Of the great importance

of drawing I have already spoken. Even sketches in outline are of great value if the size of the object has been correctly registered. Mere plans are of great use in many cases and supersede the necessity of description. This subject has, however, been fully considered already. See p. 26 to p. 35.

**276. Of Drawing Inferences from Observations.**—No one engaged in the pursuit of any branch of natural science is more tempted to be led into too hasty generalisation than the microscopical observer. It is his duty, therefore, to avoid drawing inferences until he has accumulated a vast number of facts to support the conclusions at which he has arrived. True generalisations and correct inferences promote the rapid advancement of scientific knowledge, for each new inference may form the starting point of a fresh line of investigation ; but on the other hand, every false statement, regarded as an observed fact, forms a terrible barrier to onward progress, since, before the slightest useful advance can be made it is necessary to retrace our steps, it may be for a long way, before we can hope to recommence our onward course. Again, a much greater amount of evidence is always required to overthrow a false conclusion than is sufficient to propagate the original mistake ; and there can be no task more unsatisfactory than that of being called upon to controvert the opinions and deductions of others.

In this sort of enquiry I think it is a good plan *not* to make too minute notes during the progress of an investigation, but to retain, as far as may be, the facts observed in the memory. When the whole matter is made out, but not before, we may begin writing and recording the observations. Otherwise, imperfectly observed facts are liable to be set down as actual facts, and afterwards argued upon as if they were truths. Thus the observer may gradually be led more and more astray, until he ends by adopting a conclusion totally at variance with the real truth.

Scientific enquiry ought continually to advance, and we should be able to extend our researches from the point where they have been left by our predecessors, adding successively to what they have discovered ; but the observations which we owe to them should require little correction. In not a few instances must we feel the highest respect for the careful observations of the older observers, and I fear it must be reluctantly confessed, that many of our modern researches are not carried out with the same patience, painstaking industry, and conscientious care as theirs have been, and for this reason are likely to be but short lived. Many recent observations urged with great vehemence and purporting to depend upon actual demonstration, have been set aside for others still more recent and, if possible, more

erroneous. This sort of false observation has, as would be supposed, created in some minds complete scepticism of all observation, and has deplorably retarded true progress. It is quite curious to notice how some writers condemn theory and commend what they term the observation of facts, as if it had been incontestably shown that results arrived at from speculation must be invariably false, and those from observation as invariably true. Any one who has had experience in microscopical enquiry knows how difficult it is to prove that what he sees is really the thing as it actually is in nature, and not a mere fanciful interpretation of his own. Many indeed have been the errors introduced by speculative thinkers, but I doubt if more errors are not in these days advanced by the self-styled practical observers, than by those whom the latter are ever ready to condemn as mere theoretical dreamers. A man says he has seen such and such a thing, and gives drawings of the thing seen. He explains to friends what he has seen, shows them the object in question, tells them what they are to see, and they, knowing nothing about seeing, but not liking to offend their friend, or being too lazy to trouble themselves about the matter, say they see the thing as they have been told it is to be seen. Such is the evidence which when duly chronicled and printed seems to amount almost to actual proof—and yet so many, many times has this process been repeated in the case of almost every doubtful anatomical point as to justify the conclusion that the process of observing facts is as unsatisfactory and as fallacious as the process of imagining and speculating without observing at all. At this time what a mass of thoroughly conflicting evidence is advanced on almost every question! Three or four views are taught concerning first principles of anatomical and physiological science, each one being quite incompatible with the rest, but nevertheless, supported by an immense amount of what purports to be evidence based upon observation. It is obvious in such a case that many of the statements must be false, and many of the facts advanced must be errors; and yet with what pertinacity are they maintained, and what an amount of work must be done, and what a length of time must elapse before the false facts can be demonstrated to be really false and the true facts proved to be really true!

Years must be passed in patient investigation before a man can expect to be able to trust himself as an observer of facts, and it is only by careful and unremitting exercise that he will gradually acquire habits of attentive observation and the power of thoughtful discrimination which can alone render his conclusions reliable. Indeed, though he labour hard and earnestly, he will scarcely have properly educated himself ere his powers begin to decay and he become liable

to err from the natural deterioration in structure of the organs upon which the observation of his facts entirely depends.

**277. Of Recording the Result of Microscopical Observations.**—Taking notes of microscopical observations is a subject of great importance. The observer must endeavour to acquire the habit of describing in words the appearance of objects under the microscope. This is probably not so easy as would at first be supposed, although undoubtedly many persons are able to describe what they see much more correctly, and with greater facility, than others. Accuracy in describing microscopical specimens can only be acquired by practice, and I think it a most excellent rule at first, for a student to take notes of the appearances of every object submitted to examination. The time is well spent, and much of what is so described is retained in the memory. The notes should be short, and should consist of a simple statement of points which have been observed. *Inferences* should be carefully avoided, and nothing should be stated without the observer being thoroughly satisfied of its accuracy. If he is not quite certain of any observation, he should express his doubts, or place a note of interrogation after the statement. The use of indefinite terms should be avoided as much as possible, and whenever any particular word is used, a definite meaning should be attached to it. Much confusion has arisen from the use of terms which have not been well defined. Thus the word "*granule*," is applied by many authors to a minute particle which appears as a small speck even when examined by the highest powers, as well as to a small body with a perfectly clear centre, and with a well-defined sharp outline, which would be more correctly termed a small "*globule*." So, again, the term "*molecule*" has been employed in some cases synonymously with "*granule*," but it would obviously be wrong to speak of a small globule as a molecule. It seems to me very desirable to restrict the terms "*granule*" and "*molecule*" to minute particles of matter which exhibit no *distinct form* when examined by the highest powers at our disposal, and and the term "*globule*" to circular or oval bodies of all sizes which have a *clear centre* with a *well-defined dark outline*. Other examples of the use of insufficiently defined terms might be pointed out. If an observer makes use of a term which is generally employed without any definite meaning being attached to it, he should describe at length the meaning which he assigns to it, and should, of course, use it only in this one sense.

*Exactness of Description* should always be aimed at, and we must remember that with a little trouble this exactness may be obtained with the use of a small number of words. That appearance of precision which is often aimed at by those who give long useless descriptions

cannot be too much condemned. So, also, the practice of some, of describing every object in the field of the microscope without the smallest knowledge of any one of them, has been the cause of much ridicule, and has brought microscopic observation into great disrepute. Some have thought to gain the credit of being accurate observers, by carefully measuring every object they see in every diameter, and putting down in numbers the results of this useless ceremony.

Such reports show that the author is thinking more of himself than his subject. He desires to acquire a character for extreme minuteness of observation, instead of striving to advance the real interests of the science which he professes to serve—and instead of endeavouring to excite in the mind of the reader a desire for more extended knowledge, and a wish to take part in a similar investigation, he perpetually gives undue prominence to himself. He who feels a real love for his subject, will try all he can to enlist others in the same cause ; he will try to remove all difficulties of investigation, and endeavour to express what he himself has learnt, in language which shall be intelligible to all. A certain mysterious air pervading the description of an observation,—an evident desire to coin new words, and exaggerated statements of the importance of the facts observed, are quite misplaced where all should be clear, simple, and intelligible to every one—and too often show indifference to the subject on the part of the author, and a want of consideration towards unlearned readers. Nothing, I believe, has been productive of more pain and sorrow to earnest men who have devoted their lives to the prosecution of different branches of natural science, or has more retarded the real progress of scientific enquiry, than that affectation of precision, and minute verbose and pompous style of description, which has been fashionable among some microscopists, and which pervades the writings of several authorities in this imperfectly developed branch of investigation in the present day. All this is mere pretence, and not real, earnest, useful work—distasteful to every scientific man and discouraging to every student. An extreme minuteness in description is by no means a proof of accuracy of observation. In this manner science has become encumbered with unnecessary words, and earnest men have been intimidated from prosecuting it.

*Fallacies to be guarded against in Microscopical Investigation.*

Many mistakes have arisen in consequence of sufficient care not having been taken to prevent the introduction of various substances

by accident. The most scrupulous care must always be observed in microscopical examination, and any foreign particles which may have accidentally come into contact with the preparation must be removed before it is mounted. The proceeding to be followed to remove the foreign matter, will depend much upon its nature. Mere dusting with a camel's hair brush, washing in a stream of water, or picking out the object with needles, are simple plans which are often efficient in a general way, but in some cases other processes are required.

**278. Errors of Observation.**—The important thing is to avoid making erroneous observations. One is liable, not only to draw false conclusions from observations, but the observations themselves are frequently erroneous. I propose therefore, to direct the student's attention to a few of what appear to me frequent sources of difficulty and doubt even to the most experienced.

*Of the Commencement and Termination of Tubes.*—The modes of commencement or termination of certain vessels or tubes have long been sources of dispute among observers. There are not a few instances where positive statements have been made that certain tubes commenced by cœcal or blind extremities; while contradictions equally positive have been advanced by others, who have affirmed that the very same tubes commenced as a network, and presented no blind extremities whatever. It would be supposed by many that this point might be determined beyond all doubt by injecting the tubes with some coloured material. But this is not so. Injection will frequently run up to a particular point in the minute vessels, while no force which could be employed could drive it further onwards. Here, therefore, it accumulates, and often to a very considerable extent; the portion of the tube above the constriction being considerably dilated by the pressure. Under these circumstances it may be impossible to trace the further continuity of the vessel, owing to the extreme transparency and delicate nature of the tissue of which its walls are composed. Indeed, these may be quite invisible in an unprepared specimen. The observer is thus led into the error of supposing that such tubes terminate in blind extremities, whereas they may really form a network with large meshes, or they may be continuous with other structures beyond. In fact that which was taken for the termination or commencement of the tube may really be nothing more than a bulging in a central part of its course. In many thin sections of the kidney an appearance as if the tubes terminated in free blind extremities is produced in consequence of the convolutions lying in such a position that the recurved portion is immediately beneath the most superficial part of the tube. From a mere examination of the specimen it would be impossible for any one to say that

this was not the case. In such instances the real disposition of the parts is only to be made out by a careful examination of the structure under different circumstances and prepared in various ways. Thus the idea that the tubes end by blind extremities may be shown to be quite inconsistent with the appearances observed in some particular mode of examining the texture. I am unable, however, to devote much space to the consideration of this part of my subject, or I might review the various methods in which a tissue is examined, and show how by a consideration and comparison of the different facts observed, one is enabled at length to embody the results arrived at in several different enquiries, and form an idea of the real structure of the part.

*On the Difficulty of Seeing Structures from their Transparency.*—Another fallacy arises from the great transparency of certain structures. Oftentimes a membrane may appear perfectly clear and transparent when in reality it is covered with a delicate layer of epithelium, which only becomes visible by being immersed in some special fluid or treated with some particular chemical reagent. On the other hand, there are instances in which an appearance resembling that produced by the presence of a cellular investment is perceived where no cells whatever exist. A peculiar corrugated state of uninjected capillaries, and the nuclei in the walls of the capillary vessels themselves, sometimes give rise to these mistakes. *Basement membrane*, from its extreme delicacy and transparency, is often only recognised by the folds into which it is thrown, or by the débris and granular matter which is accidentally adherent to it. Sometimes it becomes visible when immersed in a slightly coloured solution, instead of in perfectly pure water. Not only may blood and lymphatic vessels be completely passed over from their transparency, but I could adduce instances in which broad bands of connective tissue and bundles of nerve fibres existed in a specimen in great numbers although they could not be seen when the ordinary methods of demonstration were employed.

*Fibres and Membranes Produced by the Action of Reagents artificially.*—On the other hand, by the action of reagents a fibrous appearance is sometimes produced which, without care, may be mistaken for actual structure.

The addition of acetic acid to many preparations frequently produces a swelling of the tissue, with the elevation of a clear membrane-like structure, which might be termed basement membrane, but which has really been formed in this manner. Thus the outer uncalcified portion of the cells of the enamel of a young tooth, may be made to swell up into a transparent mass, which has been mistaken,

I think, by Professor Huxley for a *membrana preformativa*, which does not exist in this situation.

*A Fibrous Appearance Produced in Structureless Membranes.*—Clear, transparent, and apparently structureless membranes, when pressed, torn, and twisted, have a fibrous appearance; and delicate vessels, whose coats are perfectly transparent when pressed and collapsed, may be very easily mistaken for a form of fibrous tissue. Both capillaries and fine nerve fibres may be mistaken for fibres of elastic tissue. Indeed, capillaries uninjected and stretched, can only be distinguished from fine nerve fibres with the utmost difficulty. If any doubt exist in such a case, it may always be cleared up by injecting the capillaries of the part with a clear transparent material, like plain size, or the transparent injecting fluids, recommended in pp. 93, 94, 95, when, if the fibrous appearance is not real it will be lost; while if fibres really existed, they would still be visible. The presence of capillary vessels in a structure has been entirely overlooked in consequence of their being collapsed and shrunken, in which state they have been regarded as elements of the connective tissue.

*Collection of Oil Globules Appearing as if within a Cell.*—Oil globules in fluid not uncommonly form small and nearly spherical masses or collections, which become covered with a certain quantity of mucus or viscid matter and granules, originally contained in the fluid, so that the little intervals between the minute oil globules become filled up. The outline of the mass is perfectly clear, and sharp, and well defined, and from mere ocular examination it would be impossible to say that the oil globules were not enclosed in a cell wall. A consideration of the circumstances under which such structures have been met with, will often assist us materially in determining their real nature. Such “cells” may be prepared artificially without the least difficulty, and in some cases it would not be possible to distinguish the artificially formed *cell* from the natural *cell* by microscopical examination in water; and the process of tinting, p. 107, would only help us when the natural cells were quite fresh. It need scarcely be said, however, that with respect to the formation of these bodies there is no analogy whatever. Of the artificial cell the most external part was *last formed*. It was deposited around a collection of particles. But in the natural cell the outer part is the *oldest part*. It was produced *before* the matter in the central part of the cell was formed. Probably the only observer who still maintains that living cells are formed by the aggregation of granules, is Dr. Hughes Bennett, of Edinburgh, who also thinks that a bacterium is formed by the coalescence of already existing particles. Dr. Bennett admits, however, that such simple organisms multiply by division, and thus



affirms the doctrine that living things may be produced by the coalescence of separate lifeless particles, and increase and multiply by the division of the resulting mass. It need, however, scarcely be stated that facts now known render such a notion untenable. See a controversy upon this subject in the British Medical Journal, January, February, March, 1864.

*On the Accidental Presence of Extraneous Matters.*—Cleanliness is of the utmost importance in every branch of microscopical enquiry and without great care many substances of extraneous origin may be introduced into the specimen about to be examined, and the observer may mistake the character of the objects introduced accidentally for those of the special objects under examination. Particles of starch or other solid bodies may gain entrance into a tissue submitted to examination, and the observer may be led to conclude that these bodies were embedded in the substance of the texture.

When we consider how minute many of the structures rendered evident to the eye by the microscope are, we shall scarcely wonder that many light substances are liable to come in contact with the specimen which is under examination. The cotton or flax fibres from the cloth, starch globules which adhere to the thin glass (for the small pieces are often kept in starch), portions of feathers, various kinds of hair and oil globules are among the substances which are most frequently met with in examining different structures, and I need hardly say that their presence is purely accidental. That I am not giving needless caution upon this head, is shown by the fact that in a well-known and highly valuable publication, a drawing of what is evidently a portion of feather is described as a representation of *lymphatic vessels*,—vegetable hairs are described as *nerve fibres*, and several other errors equally unpardonable occur. Now, such mistakes could only arise from utter ignorance of the characters of some of the commonest objects with which every observer ought to be very familiar. I would very strongly recommend every one to study the characters of all these substances before he attempts to make any original observations. He is sure to meet with them from time to time, and the sooner he is well acquainted with their characters the better.

The following should be very carefully examined:—

Oil globules, milk, pl. XIX, figs. 124, 126.

Potato, wheat, and rice, starch; and bread crumbs, pl. XXXVIII, figs. 241, 241\*, and pl. XLIV, fig. 275<sup>h</sup>.

Portions of feather; worsted, pl. XLIV, fig. 275.

Fibres of flax; cotton; and silk of different colours, pl. XLIV, fig. 275.

Human hair, cat's hair, hair from blankets, fig. 275.

The scales of butterflies and moths, particularly those of the common clothes moth, pl. XLIV, figs. 273, 274.

Fibres of wood swept from the floor, fig. 276, fragments of tea-leaves, hairs from plants, vegetable cellular tissue, and spiral vessels, pl. XXXVIII, fig. 242.

Particles of sand.

Many of these extraneous substances are figured in the plates indicated, and I beg the student will not only carefully examine the drawings, but place actual specimens of all objects delineated under his own microscope.

In the examination of deposits from fluid we must bear in mind the possibility of the introduction of a small quantity of one deposit into another by the pipette used for examination, and in this simple manner much difficulty and confusion may be caused to the microscopist. The pipette should therefore be well washed immediately after it has been used, and the water in which it is washed should be very frequently changed. In taking fluids from different bottles and other vessels the possibility of introducing various substances must be borne in mind.





## PART III.

OF CHEMICAL ANALYSIS APPLIED TO MICROSCOPICAL INVESTIGATION  
—OF OBTAINING CRYSTALLINE SUBSTANCES—OF SPECTRUM  
MICROSCOPIC ANALYSIS.

OF THE ADVANTAGES OF CHEMICAL REAGENTS IN MICROSCOPICAL  
INVESTIGATION.

**279. Of Chemical Analysis in Microscopical Investigation.**—I have already referred to the influence which the refractive power of the medium in which any structure is immersed exerts upon its appearance in the microscope. We have now to discuss the advantages derived from the chemical action of certain solutions upon various specimens. This part of the subject is most important, and it is perhaps of all the various branches of microscopical research, that from which the greatest advantages may be expected to result. It is an investigation which will certainly reward all who earnestly devote themselves to its study. It is certain that great changes will take place in our views of the nature of many minute structures when chemical analysis shall be more intimately associated with microscopical enquiry.

Although by the microscope we can say that such a texture is granular, fibrous, opaque, perfectly clear, &c., we learn in such an examination nothing more of its nature. Since these appearances are manifested by several different materials, it is necessary to resort to a chemical examination to discover the nature of the substance to which the microscopical characters are due. If the composition of any body having well-defined microscopical characters has been once made out, by resorting simply to microscopical examination, we are enabled to recognise it whenever we meet with it afterwards.

Some bodies always produce well-recognised crystals when treated with a certain chemical reagent, and we know that although there may be in nature other crystals of a different composition, but of precisely the same form, these latter could not be produced under the same circumstances as the former; hence in such a case we may

feel as confident of the nature of the substance as if an ultimate analysis were made of it.

Besides the ordinary uses to which they are applied, chemical reagents are useful in removing certain components of a structure which interfere with the demonstration of other constituents, in altering the character of certain tissues without dissolving them, as for instance by increasing their transparency or opacity, or in modifying the physical structure of textures in such a manner as to render it more convenient to cut sections or to perform other chemical operations necessary for the demonstration of their structure.

By an acquaintance with the behaviour of certain substances with particular chemical reagents, and the application of this knowledge to microscopical investigation, we are often enabled to distinguish peculiarities of structure, to ascertain the chemical composition of minute quantities of matter, and to demonstrate clearly the existence of compounds with the greatest certainty, which would entirely escape our observation if we subjected them separately to the most careful chemical analysis, or to the most searching microscopical examination.

The application of chemical analysis to microscopical investigation, and the examination of crystalline forms in the microscope, has thrown a new light upon the nature of many physiological changes which are constantly taking place in living bodies in health, and has enabled us to investigate more satisfactorily the modifications which these processes undergo when influenced by circumstances interfering with or counteracting healthy actions.

**280. Instances of the Use of Reagents.**—As an instance of the great advantage of the application of a few simple tests to microscopical investigation, I may refer to the different effects of ether upon fat globules (which are so commonly found in different tissues) and crystalline bodies composed of phosphate or carbonate of lime, which sometimes resemble them so nearly in refractive properties, in form, and in general appearance, as to have led to mistakes with reference to their nature. The application of a drop of ether has no effect whatever upon the latter, but instantly dissolves the former. Phosphate of lime is readily soluble in dilute acids, while fat is not acted upon by these reagents. Various insoluble saline materials not unfrequently prevent us from seeing the anatomical elements of which a tissue is composed. A knowledge of the nature of these often enables us very easily to remove them. Suppose for instance, the saline matter consists of carbonates or phosphates of lime or magnesia, we have only to add a drop of dilute acid which dissolves them completely.

The action of acids and alkalies is often very valuable in rendering structures transparent, which are too opaque for examination in the ordinary state. If a portion of tendon, composed of white fibrous tissue, pl. XXVI, fig. 169, which is very opaque in its ordinary state, be immersed in acetic acid, or in a dilute solution of potash or soda, it soon becomes clear and transparent, and if the operation be conducted with certain precautions, many of its original characters may be brought back by subsequently neutralising the acid or alkali.

The cell wall, or rather the outer part of the cell, which is in many cases too opaque to enable us to see the nucleus in the interior, may be made by reagents perfectly transparent so that the nucleus becomes distinct and well defined. This change may be easily effected by either of the reagents alluded to in the last paragraph. Albuminous textures generally may often be rendered very transparent by the action of acetic acid, or by the addition of a drop of dilute caustic potash or soda.

**281. Preliminary Operations.**—In the first place we should note carefully the general characters which the substance exhibits; its form, colour, size, weight, hardness, &c.; and fluidity, transparency, tenacity, &c., in the case of liquids. Portions of solid textures and the deposit from fluids must be subjected to microscopical examination, but their reaction should be always ascertained in the first instance.

**282. Reaction.**—The reaction of any moist substance is found out by testing it with a piece of blue, and reddened, litmus paper. If the matter be dry, or the reaction of a vapour is to be tested, the paper must be first moistened with a drop of distilled water. The *blue litmus paper* is *reddened* by *acids*, and the *red paper* is turned *blue* by *alkalies*. The reddened litmus paper is prepared by adding a very small quantity of acetic acid to the infusion of litmus into which it is to be dipped.

If an *acid reaction* is due to the presence of carbonic acid, the blue colour will be restored upon gently warming the paper upon a glass slide over a lamp, or upon a warm plate.

An *alkaline reaction* may depend upon the presence of *volatile* or *fixed alkali*. The red colour is restored upon warming the paper which has been rendered blue by the presence of volatile alkali (ammonia or carbonate of ammonia), while it is not restored if the change is produced by the presence of a fixed alkali (potash, soda, or their carbonates, or an alkaline phosphate, &c.).

The reaction of some objects under the microscope may be ascertained by adding a little solution of litmus or of litmus slightly

reddened by the addition of a trace of acetic acid, according as the reaction is supposed to be acid or alkaline.

**283. On Filtering.**—The process of filtration is one which the microscopist as well as the chemist frequently has to perform. To filter a deposit from a solution, in quantity, is easily effected by the use of ordinary filtering paper, folded, pl. XXII, fig. 147, and placed in a small glass funnel, fig. 139, pl. XXI. But sometimes we find it necessary in microscopical analysis, to filter the deposit from a single drop of fluid. This may be effected by cutting a very narrow strip of filtering paper, and bending it into a V-form, upon one of the glass slides. The drop is made to pass between the limbs of the V, and upon inclining the slide, clear fluid will gradually pass through the apex of the V, and can be conducted away to another part of the slide, by a very fine glass rod, where other tests may be applied.

**284. Evaporation and Drying.**—The evaporation of fluids, and the desiccation of organic solids, must always be conducted over a water-bath, otherwise there is great danger of decomposition occurring. For operations upon small quantities, the water-bath represented in pl. XIV, fig. 73, will suffice, or the cans of the injecting apparatus, pl. XXIII, fig. 152, may be removed, and basins placed over the holes.

In endeavouring to obtain crystals of organic substances, it is always advantageous to evaporate the solution over the surface of sulphuric acid under a bell-jar, pl. XX, fig. 131, or, what is better still, in vacuo, pl. XX, fig. 129. In some instances, the evaporation may be conducted by simply exposing the liquid placed in a basin or watch-glass, and covered lightly with paper, to the air; or, where very slow evaporation is necessary, the watch-glass may be covered over with a bell-glass.

**285. Incineration.**—By incinerating a small portion of any organic substance, upon a piece of platinum foil, or in a platinum or porcelain crucible, we are enabled to ascertain whether it contains inorganic salts, or consists entirely of organic matter, in which case the substance leaves only a black residue, which burns off entirely after a short time. In order to obtain the inorganic constituents perfectly free from carbon, it is sometimes necessary to keep the mass at a dull red heat for a considerable time. The addition of a drop of nitric acid, causes the rapid oxidation of the carbon. If, however, the temperature be too high, the process may be much retarded, in consequence of the fusion of some of the salts, as the phosphates and chlorides, and the inclusion of small masses of carbon, which are thus protected from the action of the atmosphere. The



platinum basin or foil may be supported over the lamp upon coarse wire gauze or upon a piece of wire, bent in the form of a triangle, or upon one of the small rings attached to the spirit lamp, pl. XIV, fig. 70. It may be removed from the lamp with the aid of an old pair of forceps.

**286. Apparatus.**—The chemical apparatus necessary for the microscopical observer is very simple, and the greater number of instruments have already been referred to. The following are among the most important pieces of apparatus :—

A few conical glasses of different sizes. Apparatus for taking specific gravities. Test-tubes of various sizes, arranged on a stand, pl. XLV, fig. 282. Spirit-lamps, with various supports, pl. XIV, fig. 70, or, where gas is laid on, the gas-lamp, pl. XI, fig. 49. Glass funnels and filtering paper, pl. XXII, figs. 139, 147, small porcelain basins, watch-glasses; a simple water-bath, pl. XIV, fig. 73, or the injecting can, pl. XXIII, fig. 152, may be used, if several evaporations are to be conducted at once. A small platinum capsule, a strip of platinum foil, a blow-pipe, pipettes, pl. XXII, fig. 140, and glass stirring rods, with a box of reagents in small bottles, pl. XLV, fig. 279, and test papers, complete the apparatus. All these may be obtained, packed in a box of convenient size, fig. 284.

**287. Microscope for Examining Substances Immersed in Acids and Corrosive Fluids.**—If preparations which require to be immersed in strong acid, be examined in the ordinary microscope, the fumes may injure the brass work of the instrument. Considerable inconvenience is also experienced in examining fluids while hot, in consequence of the vapour rising and condensing upon the object-glass, and thus rendering the object invisible.

The ingenious microscope invented some years ago by Dr. Lawrence Smith, obviates these objections. This inverted microscope has been described in p. 183, and is represented in pl. XLIII, fig. 271.

#### REAGENTS AND THEIR ACTION.

The reagents necessary for the microscopist are not very numerous. They should be perfectly pure.\* Of the greater number only very little is required, as much as may be kept in drachm or two drachm bottles; but of alcohol, ether, and one or two others, it is necessary to have a half-pint or more. The stock reagents should be kept in stoppered bottles of about the capacity of two ounces.

**288. Distilled Water** should alone be employed for dissolving

\* Pure chemicals may be obtained of Mr. Griffin, Long Acre.

substances to be tested, and for diluting fluids required by the microscopical observer.

**289. Alcohol.**—Alcohol of different strengths will be required for the purpose of dissolving certain substances, and for separating them from other constituents, which are insoluble in this reagent. If a weak alcohol is required, the strong spirit should always be diluted with distilled water, and it is better to prepare a considerable quantity at a time. It is convenient to have two or three bottles which will hold about two quarts each. The strength of each should be written upon a label attached to the bottle. The importance of alcohol as a preservative solution has been referred to in p. 53.

**290. Ether, Chloroform.**—An ounce or two of ether will be quite sufficient for microscopical purposes. It should be kept in a stoppered bottle, provided with a glass cap, to prevent loss by evaporation. A little should also be kept in one of the small glass bottles with capillary orifices, p. 209, for the convenience of applying to cells containing highly refracting globules, resembling oil, &c., under the microscope. Chloroform must be kept in capped and stoppered bottles, carefully protected from the light.

**291. Effects of Alcohol and Ether.**—Alcohol coagulates albuminous matters. Germinal matter is always rendered granular by this reagent. Many transparent tissues are corrugated, and rendered more or less opaque by alcohol. It dissolves certain forms of fatty matter, resinous materials, and many kinds of vegetable and animal colouring matter.

Ether is of great use for dissolving various kinds of fatty matter. In many cases, however (as, for example, in common milk), the oil globule is covered with a caseous or albuminous investment, which protects it from the action of the ether. In this case it is necessary to add a drop of acetic acid, or solution of potash or soda, to dissolve the membrane, when the ether will at once act upon the fat.

Chloroform is a valuable fluid for dissolving Canada balsam, p. 51.

**292. Nitric Acid** of two different degrees of concentration should be kept, the strongest that can be procured, and a solution containing about twenty per cent. of the strong acid. This last is the acid most used by the microscopist, especially in separating muscular fibre cells. It is prepared by mixing one part of the strong commercial acid with five parts of distilled water.

**293. Sulphuric Acid** is sometimes required undiluted, but a small bottle of diluted acid (one of acid to five of water) should also be at hand. The pure colourless acid should always be procured; it is to

be purchased for about 1s. 6d. a pound, but only very small quantities are required.

**294. Hydrochloric Acid** may be obtained perfectly colourless. It should be kept in the pure state and diluted as required.

**295. Acetic Acid.**—Two specimens of acetic acid will be found convenient. One, a solution of the strongest acid which can be procured; the other containing about twenty per cent. The last is prepared by dissolving one part of the strongest liquid acid, or of the pure *glacial acetic acid*, in five of water.

The glacial acetic acid is now commonly employed for photographic purposes, and can, therefore, be very readily obtained. It possesses great advantages over other kinds of acid for microscopical purposes.

**296. Chromic Acid** is usually required very dilute. For the purposes of hardening tissues a watery solution of a straw colour will be found strong enough. It is easily prepared by dissolving a little of the crystallised chromic acid in distilled water.

The crystallised acid may be prepared by decomposing 100 measures of a saturated solution of bichromate of potassa, by the addition of 120 to 150 measures of pure concentrated sulphuric acid. As the mixture becomes cool, crystals of chromic acid are deposited, which should be dried and well pressed on a porous tile, by which means the greater part of the sulphuric acid is removed, and the crystals obtained nearly pure.

**297. Effects of Acids on Organic Structures.**—The effects of the application of cold strong acids to animal textures are very variable; in some instances the tissue is completely destroyed, while in others scarcely any effect seems to be produced. The mineral acids generally coagulate albuminous tissues, and render their microscopical characters confused and indistinct. Tribasic phosphoric acid, however, is an exception to this.

Acetic acid dissolves many of the substances allied to albumen. The appearance of some textures is scarcely altered by the application of a strong acid; for instance, the blood corpuscles shrink a little, but exhibit their usual form and general characters for some time after the addition of strong nitric acid, and the cells of the epidermis and nail, although turned of a yellow colour, are not destroyed; the latter are separated somewhat from each other, and their outline is often made beautifully distinct. Most of the mineral constituents of the body, insoluble in water, are directly dissolved by the acids. Strong nitric acid is a very useful reagent for demonstrating vegetable cellular structures.

*Acetic Acid.*—Acetic acid is one of the most useful reagents to

the microscopical observer. It has the property of dissolving granular matter composed of albuminous material, and causes the cell-wall and many kinds of formed material to become very transparent; although it often renders the nucleus darker and more distinct. In many instances the action of the acid upon the cell-wall is curious; the formed material becomes more pulpy and thicker, and approaches in tenuity and refracting power the solution in which it is immersed. In numerous instances, by adding a saline solution to cells which have been previously rendered transparent by acetic acid, they again contract, and the outline becomes distinct. In some cases, however, the outer part of the cells is actually dissolved by the acid, and the germinal matter is set free. Acetic acid is very frequently used to make epithelial structures transparent, in order that the arrangement of the minute vessels and nerves in papillæ, &c., may be demonstrated, as in the case of the tongue, skin, &c. Sections of preparations which have been hardened by maceration in alcohol, may require to be boiled slightly in acetic acid to render them transparent. The action of acetic acid on white fibrous tissue is very characteristic, as it converts it into a transparent jelly-like mass, in which a few nuclei are visible. Upon the yellow element, on the other hand, this reagent exerts no action whatever.

Acetic acid may also be employed for testing crystalline bodies, as phosphates and carbonates. By it phosphate or carbonate of lime may be distinguished from oxalate of lime (all which are insoluble in water), by dissolving the two former, while it does not affect the latter even if boiled with it. The action of acetic acid, upon any particular tissue, upon any form of cells, fibres, &c., that are subjected to examination, should always be specially noted. Many tissues are quite insoluble in acetic acid, though they are not rendered opaque by it.

*Nitric Acid.*—Strong nitric acid dissolves albuminous substances, but first colours them deep yellow. Dilute nitric acid is much employed in microscopical research.—An acid composed of one part of acid to two or three of water, forms a good solution for hardening some structures previous to cutting thin sections. The thin sections may sometimes be rendered very transparent by being treated afterwards with dilute caustic soda. For demonstrating muscular fibre-cells, nitric acid is a valuable reagent. For this purpose the solution should contain about twenty per cent. of strong acid, and the muscular fibre should be allowed to macerate in it for some days, when small pieces may be removed with scissars, and after being carefully torn up with fine needles, subjected to examination.

When we wish to obtain portions of glandular structure isolated from one another, it is a good plan to soak the tissue for some days in dilute nitric acid (one part of acid to six or seven of water), when the areolar tissue becomes softened. At the same time the gland structure is rendered more firm, and may be isolated very readily with the aid of needles. In this manner the gastric glands, the secreting follicles of the pancreas, and salivary glands may often be very satisfactorily demonstrated.

By boiling animal tissues in strong nitric acid, they become destroyed, while any siliceous constituents remain behind unaltered. In this manner, the siliceous skeletons of the *Diatomaceæ* may be separated from any organic matter with which they may be combined. This is one of the processes employed for obtaining these beautiful objects, from guano.

*Sulphuric Acid.*—*Hydrochloric Acid.*—Concentrated sulphuric acid causes epidermic structures to swell up very much, and the cells to separate from each other so as to be readily isolated. Boiling acid completely dissolves them. In the examination of hair, strong sulphuric acid will be found to render the outline of the cells very distinct.

Hydrochloric acid is usually employed for dissolving out the mineral constituents of certain tissues, such as bone or teeth. As a rule, it is better to use dilute acid (one of acid to three or four of water), in which case, however, a longer time must of course be allowed, than when the acid is concentrated.

**298. Solution of Potash** should be kept of two or three different degrees of strength. One, the strongest which can be obtained; another, made by mixing one part of the strong potash with three or four of water; and a solution consisting of one part of liquor potassæ to eight or ten of water will be found of a useful strength for the examination of many preparations.

**299. Solution of Soda** is generally required very dilute. It may be made by mixing one part of the strong solution of the shops with five or six of water; but this, for many purposes, will require to be still further diluted. Or, about twenty-five grains of the fused soda may be dissolved in an ounce of distilled water.

**300. Ammonia.**—Solution of ammonia, made by mixing one part of the strongest liquor ammoniæ (British Pharmacopœia) with three of water, will be found sufficiently strong for all the purposes for which this reagent will be required.

**301. Effects of Alkalies on Organic Structures.**—The action of alkalies, even when cold in a very dilute state, is to dissolve most animal textures. Cell-membranes are frequently almost instantly

dissolved, while the nucleus (germinal matter) appears to be altered but slightly.

Alkalies are also employed for dissolving certain crystalline substances which are occasionally found in animal tissues, such, for instance, as the urates.

The action of potash and soda upon animal structures is very similar. Both dissolve substances of an albuminous nature, but the effect of soda is more gradual, and it has been found that for most purposes in microscopical research, the reagent possesses advantages over potash.

The solution of potash required by the microscopist is the ordinary *liquor potassæ* of the pharmacopœia, and the solution of soda is prepared in the same manner. These solutions may be diluted with water to the required strength. Potash and soda are employed where a tissue is to be rendered more transparent for the purpose of demonstrating the arrangement of the nerves or other anatomical elements not soluble in this reagent.

These reagents dissolve the layer of epithelium covering mucous membranes, or render it perfectly transparent, so that the arrangement of the structures beneath the basement membrane can be easily demonstrated. In investigating the arrangement of the nerves and vessels in papillæ and other structures, they are very valuable, especially the soda solution.

For the purpose above-mentioned, the alkalies should be diluted with water. The changes are expedited by the application of heat, which, however, must not be too great, for fear of complete solution taking place. The structure may be heated with the solution in a test tube.

Some animal textures become hardened by prolonged maceration in carbonate of potash, but this plan does not appear to be so generally useful as others previously indicated. Epidermic structures are not much altered by this salt.

The introduction of different chemical solutions by injection, will be discussed in Part V. I strongly recommend this plan of subjecting the tissue to the action of the reagent. *See* also Part V.

**302. Nitrate of Barytes.**—A cold saturated solution of the salt forms a test solution of convenient strength. It should be filtered before use. A solution of nitrate of barytes is employed as a test for sulphuric and phosphoric acids. The precipitated sulphate of baryta being insoluble both in acids and alkalies; while the phosphate of baryta is readily soluble in acids, but insoluble in ammonia.

**303. Nitrate of Silver.**—A solution of nitrate of silver is prepared by dissolving one hundred and twenty grains of the crystallised nitrate in two ounces of distilled water, and filtering if necessary. Nitrate of silver is employed as a test for chlorides and phosphates. The *white* precipitate of chloride of silver is soluble in ammonia, but insoluble in nitric acid. The *yellow* precipitate of tribasic phosphate of silver is soluble in excess of ammonia, as well as in excess of nitric acid.

**304. Oxalate of Ammonia.**—Some crystals may be dissolved in distilled water, and, after allowing time for the solution to become saturated, it may be filtered. Oxalate of ammonia is used as a test for salts of lime. Oxalate of lime is insoluble in alkalis and in acetic acid, but soluble in the strong mineral acids. In testing an insoluble deposit for lime, it may be dissolved in nitric acid and excess of ammonia added; the flocculent precipitate is readily dissolved by excess of acetic acid, and to this solution the oxalate of ammonia may be added. The precipitation of oxalate of lime is favoured by the application of heat. Many deposits of phosphate are with great difficulty soluble in acetic acid, hence the necessity of first adding nitric acid, as above directed.

**305. Iodine Solutions.**—An aqueous solution is easily prepared, by dissolving a few grains of iodine in some distilled water, until it acquires a brownish-yellow colour. A solution of iodine is sometimes useful for colouring certain animal and vegetable textures, which are so transparent as to be scarcely distinguishable upon microscopical examination. In the examination of many such structures, great assistance will be obtained from the use of coloured solutions; for delicate textures, like the cell-wall and basement membrane, &c., can be far better distinguished when a faint tint is communicated to them, than when perfectly colourless. When a membrane is to be made more distinct, it may be immersed in a little Prussian blue fluid, p. 93, the minute particles of which adhere to it, and enable us to trace its outline clearly. A weak solution of magenta answers the same purpose.

Iodine is principally employed as a test for starch which is rendered blue by an aqueous solution, even when very dilute. Albuminous matters and tissues are coloured yellow by iodine, and vegetable cellulose also receives a brownish-yellow tinge. The addition of sulphuric acid (one part of the strong acid, two parts of water) to albuminous matter stained with iodine, causes no change, but cellulose under the same circumstances becomes blue. In cases where substances allied to starch and cellulose (amyloid matters) are found associated with the albuminous matters, a purple, bluish,

or greenish tinge results from the action of iodine and sulphuric acid.

A strong solution of iodine may be obtained by employing a solution of iodide of potassium to dissolve the iodine (one grain of iodine and three grains of iodide of potassium, to one ounce of distilled water or glycerine).

Schultz recommends the following iodine solution. Zinc is dissolved in hydrochloric acid;—the solution is permitted to evaporate in contact with metallic zinc until it attains the thickness of a syrup; and the syrup is then saturated with iodide of potassium. The iodine is next added, and the solution, if necessary, is diluted with water. Professor Busk gives the following directions for preparing this solution: one ounce of fused chloride of zinc is to be dissolved in about half an ounce of water, and to the solution (which amounts to about an ounce fluid measure), three grains of iodine, dissolved with the aid of six grains of iodide of potassium, in the smallest possible quantity of water, are to be added (*Trans. Mic. Soc.*, vol. I, p. 67). I have employed a solution prepared in this manner, and can speak very highly of its utility. In making it, it is necessary not to *fuse* the chloride of zinc much, or to use a very high temperature, as decomposition is very apt to take place. In testing starch with this solution, it is advisable to add a very little water, as the solution frequently will not act in its concentrated form.

#### OF APPLYING TESTS TO MINUTE QUANTITIES OF MATTER.

**306. Method of Applying Tests to Substances intended for Microscopical Examination.**—The matter to be tested may be placed upon a glass slide, and, if necessary, a drop of water added, to moisten or dissolve it, as the case may be.

In these operations we usually require only a small drop of a solution, and it will be found most convenient, in applying it to the object, to take a drop from the bottle by dipping a stirring-rod into it, and withdrawing it immediately. Enough will be found adhering to the stirring-rod for the purpose required. The rod should not be dipped in a second time, without being first well washed in water,—for if this be not scrupulously attended to, there is great danger of conveying some of the substance intended for examination into the test bottle, in which case the whole contents would be spoiled. Without great care in all our manipulations, there will be much danger of removing a portion of one substance from a glass slide and carrying it to a specimen which is examined subsequently.



Accidents of this kind can always be avoided, by not allowing the drop of the reagent to touch the deposit until the rod has been removed. The drop may be placed near the substance intended for examination, and then allowed to come into contact with it, either by inclining the glass slide, or by leading it with a glass rod, to the matter to be tested.

**307. Bottles with Capillary Orifices.**—The above tests may be preserved in ordinary stoppered bottles, but I much prefer to keep them in small tubes with capillary orifices, from which only a drop, or a part of a drop, can be expelled when required. Several years since I arranged all the ordinary tests I required for microscopical purposes in small bulbs which were drawn off to a capillary point. They were provided with glass and gutta percha caps. These bulbs, however, were somewhat inconvenient in consequence of not being made to stand upright, and Mr. Highley substituted for them tubes with flat bottoms and ground glass caps, pl. XLV, figs. 278 to 281. To fill these bottles I proceed as follows:—A little of the solution is poured into a small basin, the tube being inverted so that its orifice dips beneath the surface of the fluid. Heat being now applied to the body of the bulb, the air in its interior is expanded and partially expelled. As the bottle becomes cool, a certain quantity of the fluid rises up into its interior. Usually, however, it is not possible to introduce more than a few drops in this manner. The bottle is then removed and heated over the spirit-lamp until the drop of fluid in its interior is in a state of ebullition. While the steam is issuing violently from the orifice, I carefully plunge it again beneath the surface of the fluid. As the steam within condenses, the solution rises up in the interior, and would completely fill the little bottle if it were maintained in this position, but when it is about three parts full it may be removed from the fluid. If I were to fill it completely it would be difficult to expel the fluid when required. A certain quantity of air, therefore, is allowed to remain within the bottle, and being expanded by the warmth of the hand, the quantity of fluid required can be driven out at pleasure.

Mr. Highley has made a further modification by arranging the capillary neck in the form of a tubulated stopper, by the removal of which, fluid can be introduced as in filling an ordinary bottle, fig. 280. For microscopical purposes bottles with capillary orifices possess many advantages over the ordinary stoppered bottles in which tests are usually kept.

In the *first* place, a most minute quantity of the test can be obtained without difficulty, and there is no chance of too much escaping.

*Secondly*, there is no danger of the reagent becoming spoilt by the introduction of various substances from without. If an ordinary stoppered bottle be used, a drop of the fluid must be removed with a pipette or stirring-rod, but if these should not be quite clean, foreign substances may be introduced, and the reagent spoilt for further operations. Carelessness upon this head will lead to the greatest inconvenience, and give rise to serious mistakes.

*Thirdly*, testing by means of these little bottles can be conducted in a very short space of time, and they possess the advantage of being packed in small compass, pl. XLV, figs. 279, 284.

**308. Capillary Tubes with India-rubber tied over the Top.**—Dr. Lawrence Smith recommends that the tests should be kept in bottles of two ounce capacity, and instead of a stopper, he inserts a tube in the form of a pipette, the upper open end of which is covered with a piece of vulcanised India-rubber, fig. 283. By pressing this while the lower end is beneath the fluid, a portion of the air is of course driven out, and a little fluid rushes in to supply its place as soon as the pressure is removed. The tube with the contained test solution may then be removed from the bottle, and by again pressing the India-rubber, a drop, or a portion of a drop, is very readily expelled.

**309. Testing for Carbonate and Phosphate of Lime, Phosphate of Ammonia and Magnesia, Sulphates and Chlorides.**—Suppose the nature of the substances composing certain forms of earthy matter is to be ascertained. A small portion, about the size of a pin's head, is placed upon the slide, and covered lightly with a piece of thin glass. Next, a drop of *nitric acid* is placed near to the thin glass. The acid soon reaches the sediment, and the disengagement of a few bubbles of gas may be observed. These are, as it were, temporarily pent up by the thin glass. If there should be any doubt about the action of the acid, we may resort to examination in the microscope, when, if there be very few bubbles, they may be detected. The formation of bubbles of gas indicates the presence of a *carbonate*.

The acid solution may be neutralised with *ammonia*, when a faint flocculent precipitate may be produced. After this has stood still for a few minutes it should be covered with thin glass and examined under the microscope. It may consist of amorphous granules and small crystals, which, if allowed to stand long enough, will take the form of triangular or quadrangular prisms (phosphate of ammonia and magnesia, phosphate of lime).

If we wish to ascertain the presence of sulphates, a little of the nitric acid solution is treated with *nitrate of barytes*. An amorphous



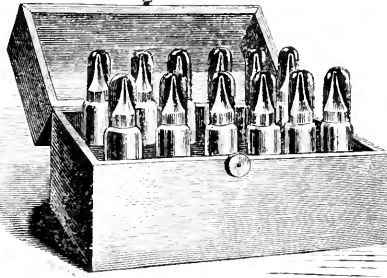
Small test bottle, with capillary orifice. p. 200.

Fig. 253.



Pipette serving as the stopper to the bottle. a, rubber and India rubber by pressure which fluid may be expressed from the tube b around to fit the neck of the bottle. c, the orifice. p. 210.

Fig. 271.



Assortment of small test bottles with capillary orifices. p. 200.

Fig. 255.

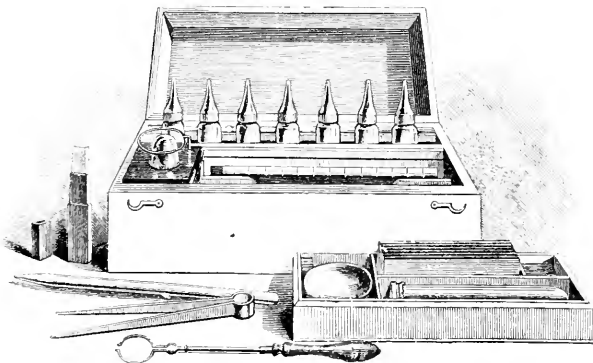


Rack for holding test tubes. p. 201.



Test tubes and stand. p. 201.

Fig. 284.



Assortment of glass apparatus. p. 200.

Fig. 275.



Bulb with capillary orifice for testing small quantities of matter. p. 200.

Fig. 281.



Test bottle, with capillary orifice. p. 200.



precipitate of sulphate of baryta, insoluble in strong acid and alkalies, takes place, if sulphuric acid be present. The presence of chlorides is detected by the addition of a little *nitrate of silver* to a drop of the solution of the deposit in weak nitric acid. The white precipitate of chloride of silver is insoluble in *nitric acid*, but is dissolved by *ammonia*.

The above will serve as examples of the method of detecting the presence of different substances in a very minute quantity of matter. The indications obtained in this manner are quite as valuable, and may be relied upon with as much certainty, as if we were provided with a very large quantity of material to work upon. In a single drop of a composite solution, the presence of several different acids and bases may be detected.

**310. New Method of Microscopical Analysis.**—Since I have been in the habit of using glycerine as the basis of all my injecting fluids and preservative solutions, I have employed it as the solvent of all tests, and with the greatest advantages. The reactions are of course slower, but much more perfect. Crystals can be formed most readily by this process, and as the viscid solutions mix very slowly, most perfect crystals even of substances which crystallise with great difficulty in water, can be readily obtained. If glycerine be added gradually to many solutions of crystallisable matter crystals are deposited. The various tests may be dissolved in a little water and then added to Price's glycerine. The iodine reactions can often be obtained most satisfactorily by this mode of proceeding. The solutions may be kept in the little glass bottles described in p. 209. Very strong solutions of the nitric and sulphuric acids cannot be obtained in glycerine, but it is seldom that a stronger solution than one part of acid to five of glycerine is required. If a very strong viscid solution of acetic acid be wanted, the acid may be warmed with lump sugar in sufficient quantity to make a fluid of the consistence of syrup. Glycerine may be employed as the universal medium for the examination, preservation, and qualitative analysis of microscopic objects. It need scarcely be said that glycerine and syrup are miscible, so that the viscosity of any fluid can be readily increased by the addition of sugar to it.

*Of obtaining Crystalline Substances from the Fluids and  
Textures of Organism.*

**311. Formation of Crystals.**—Some crystalline bodies are deposited from their solution in animal fluids by simple evaporation; others, less soluble, may be deposited by allowing the fluid

to stand still for a short time, when certain changes occur in some of its constituents, which lead to the precipitation of some bodies in a crystalline form, as for instance, uric acid, or triple phosphate. In other cases it becomes necessary to add some reagent before the crystals are thrown down, while not unfrequently a long and often complicated chemical analysis is necessary if substances which were previously held in solution, are to be obtained in a crystalline form. The addition of water in some cases causes the most rapid crystallisation, especially when the crystallisable material is dissolved in viscid organic matter, as when water is added to blood, in order to obtain blood crystals. Instead of water, in other instances, alcohol, ether, or chloroform, in which the crystals may be much less soluble than in water, is to be preferred.

Crystalline substances which are dissolved in animal fluids, may often be separated in a perfectly pure state by the addition of another fluid in which they are not so readily soluble. This last should be added very gradually, to allow time for the formation of the crystals, otherwise an amorphous precipitate alone results. Many organic substances soluble in alcohol, may be crystallised by the addition of ether, while some are precipitated from their solution in water, by the gradual addition of alcohol.

### **312. Influence of various Constituents upon the Crystallisation.**

—In many instances, it is exceedingly difficult to separate some crystalline bodies from other constituents by which their solubility is much increased, and crystallisation is often prevented. The extractive matters of blood, and of many organic fluids, exert this influence in a marked degree, and it is only of late years that several new bodies of definite chemical composition have been isolated. Creatine and creatinine may be instanced amongst the number, for these were not very long ago included under the indefinite term “extractives.” Certain colouring matters of definite composition have also been separated, and it is very probable that as the methods of analysis at our disposal become improved, many new crystalline bodies will be isolated from the extractive matters. A very small quantity of extractive matter entirely prevents the crystallisation of urea, while the presence of chloride of sodium or common salt favours the separation of this material by forming with it a compound which readily crystallises in large octohedral crystals even in the presence of extractive matters. The existence of carbonic acid in excess may cause carbonate of lime, triple phosphate, and other salts, to be held in solution. Excess of alkali prevents the precipitation of uric acid, and excess of acid, that

of phosphate of lime. Fatty matters dissolve cholesterine, and serum possesses the power of retaining small quantities of both the latter substances in solution. Some crystalline bodies which are soluble at the temperature of the body, crystallise when the solutions containing them are cooled thirty or forty degrees. The effect of dilution in retaining crystals in solution, need scarcely be alluded to. Hence, before the presence of many substances can be detected by microscopic examination, certain chemical operations are required in order to separate them from their combinations in the animal body, or for the removal of other substances which interfere with their crystallisation.

**313. Separation of Crystals from Animal Substances.**—From what was stated in the last section, it follows that in many instances this is a matter of some difficulty. Not unfrequently, if not very soon separated from the fluid in which they were formed, the crystals again undergo solution or become decomposed. If the crystals are not very soluble, the supernatant fluid, or mother-liquor, may be poured off,—the crystalline deposit washed with ice-cold water, and subsequently dried on filtering paper over sulphuric acid without the application of heat.

If the crystals will not bear the application of water, as much of the fluid as possible must be poured off, and the remainder absorbed with bibulous paper, or they may be placed upon a porous tile, and dried over sulphuric acid in vacuo. In many instances we are enabled to wash the crystals with water, holding a little acid or alkali, or some alkaline salt, in solution, or with alcohol, ether, or some other fluid in which we know them to be quite insoluble.

In cases in which crystals insoluble in water are deposited in animal solids, they may be separated by agitation, when, being heavier than the water, they subside to the bottom, and the lighter animal matter may be removed by forceps, or if in a very minute state of division, poured off with the supernatant fluid. In other cases, it may be separated by straining, while the crystals are washed through muslin.

**314. Of obtaining Crystals for Examination.**—In order to accustom himself to the necessary manipulation required in the process, the student may evaporate a solution of common salt upon a glass slide, and when it has become sufficiently concentrated it may be covered with a small piece of thin glass, and allowed to cool. When cold it may be subjected to microscopical examination. Beautiful cubes of chloride of sodium will be observed, pl. XLII, fig. 270. Crystals of several salts may be made in the same simple manner, and from an attentive examination of them, much may be learned. Phosphate of Soda, Phosphates of Soda and Ammonia,

Sulphates of Potash and Soda, Muriate of Ammonia, Borax, Alum, Sulphate of Copper, Biniiodide of Mercury, and a variety of other salts, can be readily obtained in microscopical crystals in this manner. Mr. Glaisher has made some beautiful observations on snow-flakes. Copies of his drawings are represented in pls. XLVI and XLVII, figs. 285 to 303. Among organic crystalline substances may be mentioned, Quinine, Iodo-sulphate of Quinine, Salicine, Brucia, Oxalic Acid, and Oxalates, particularly Oxalate of Ammonia.

Different faces of the crystal, as it lies in the liquid, may be brought into view by slightly moving the thin glass cover with a fine-pointed instrument, such as a needle, while the preparation is in the field of the microscope. With a little practice, crystals may in this manner be made to rotate in the mother-liquor. Crystals which are precipitated by the addition of some reagent, such as nitrate of urea by nitric acid, must be examined in a little of the solution. The addition of water would, in many instances, destroy them immediately. Crystals of muriate of ammonia and creatine are represented in pl. XLVII. Other crystals are seen in pls. XLII, XLVIII, and XLIX.

The influence of the crystals upon polarised light should be examined, and in cases in which the nature of the crystal has not been ascertained, its angles should be carefully measured, and accurate drawings made. Their behaviour with chemical reagents is next to be ascertained, and their solubility in water, alcohol, and other fluids must be noted. For these experiments different portions must be taken and separately tested in the manner referred to in p. 208.

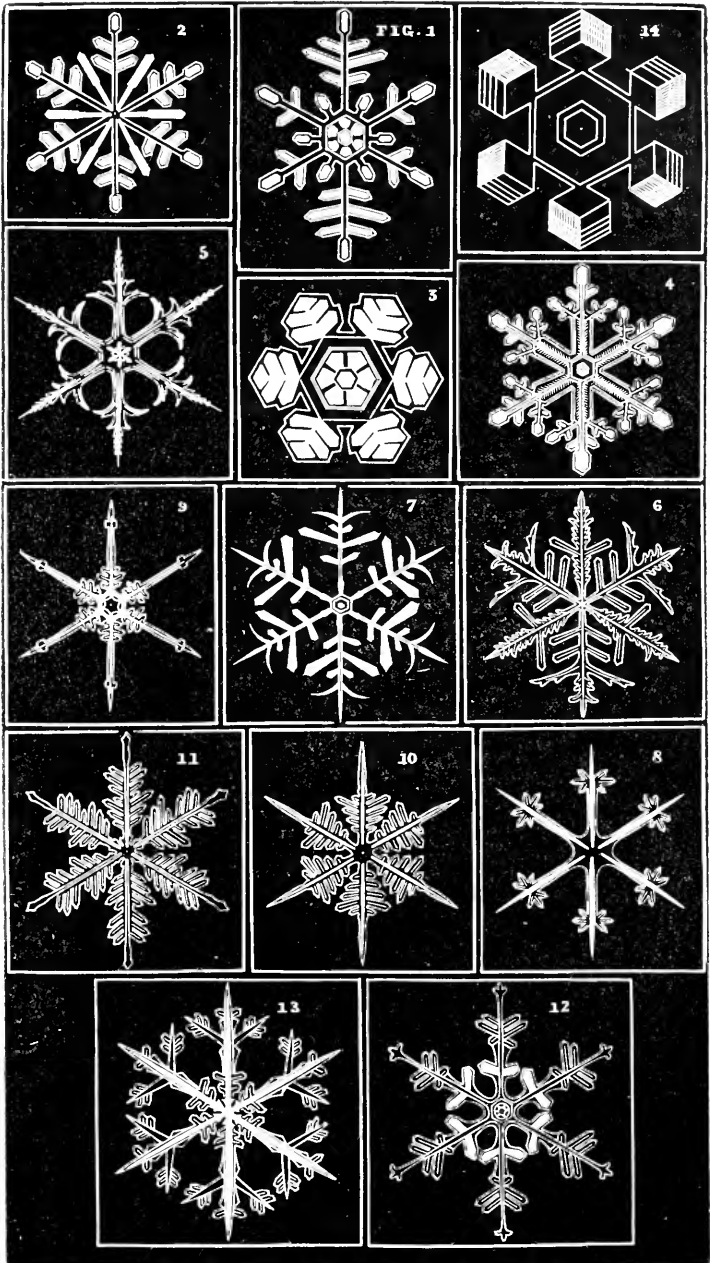
A drop of the solution may also be evaporated rapidly nearly to dryness, and allowed to crystallise upon the slide without being covered over, when the substance will often be found to assume a variety of beautiful forms, such as crosslets, dendritic expansions, &c., which vary according to the rapidity with which the evaporation has been conducted, and other circumstances.

Mr. Thomas Davies has obtained some beautiful results by crystallising mixed salts, some of which exhibit a re-arrangement of crystalline form after fusion. A mixture of sulphate of copper and sulphate of magnesia, and sulphates of zinc and magnesia form good examples. They must be examined with the aid of polarised light and a selenite plate. *See* the copies of the photographs of the salts in Mr. Davies's second paper in the *Microscopical Journal* for July, 1865, p. 205.

By carefully crystallising a solution of sulphate of copper at various degrees of temperature, Mr. R. Thomas, of Oxford, has succeeded in obtaining a series of crystalline forms of a peculiar



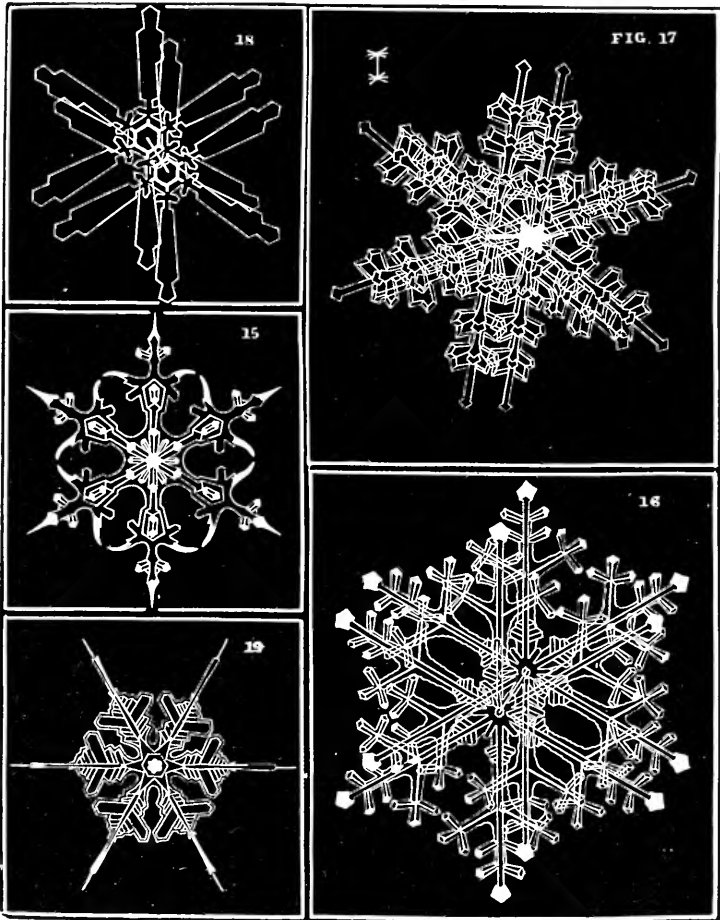
Figs 95-106



Various forms of snow crystals, drawn by Mr. Glasher in the winter of 1855  
 Mic Journ. Vol. III, p. 179 - p. 214.



Figs. 299-303.



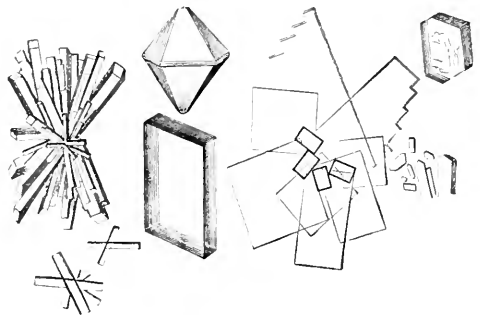
Various forms of double snow crystals, drawn by Mr. Glaisher. p. 214.

Fig. 304.



Dendritic crystals of muriate of ammonia. p. 214.

Fig. 305.



Crystals of creatine. p. 214.



character. From the fact that throughout the series the crystals radiate from centres in a more or less spiral manner, Mr. Thomas has designated the process as "spiral crystallisation."

The solution of sulphate of copper is evaporated by a moderate heat, until an uncrystallised film is obtained. This film being subjected (after the manner indicated in Mr. Thomas' paper, contained in the *Microscopical Journal* for July, 1866, p. 177), to a temperature of about 60° Fahrenheit, a number of foliated crystals, all radiating from centres, appear. There is in this stage a slight curve or twist in the radiation, and this constitutes the first stage of the spiral, as represented in pl. XLVIII, fig. 306. At a temperature of 65°, a further advance is seen in the direction of the spiral, fig. 307. At 70° (fig. 308) the spiral appearance is yet more distinct. While at temperatures of 80°, 90° and 100°, the lines are smaller and more numerous, and the spiral more perfect and symmetrical, fig. 309. Fig. 310 shows a perfectly formed crystal which had been allowed to crystallise upon a slide, carefully protected from dust. Mr. Thomas believes that these crystals are in reality cones standing out in relief upon the glass slide. The changes in form which occur in crystals of the double salt, sulphate of magnesia, sulphate of zinc, upon the application of a gentle heat subsequent to crystallisation has been further prosecuted by Mr. Thomas, of Oxford, whose figures are given in pl. XLIX. See also *Microscopical Journal* for April, 1866, p. 137.

**315. Examination of Crystals under the Microscope.**—Some crystals which have been entirely separated from the fluid in which they were originally deposited, may be examined in the dry way, in water, or other fluid in which they are known to be insoluble, or in Canada balsam; but as a general rule, it is necessary to examine the crystals as they lie in some of the fluid in which they have been formed. When they have been obtained by allowing a concentrated solution to cool, some of the inspissated fluid must be removed with the crystals, placed upon a glass slide or in a thin glass cell, covered with a piece of thin glass, and examined in the usual way—first using a low power (an inch), and afterwards a higher power (a quarter), because, although some of the crystals are of a large size, others amongst them, the form of which is very perfect, are often exceedingly minute. The crystals and mother-liquor should not be exposed to the air previous to examination, for in many instances water is absorbed, and partial solution takes place.

**316. Preservation of Crystals as Permanent Objects.**—The preservation of the more soluble crystals is attended with the greatest difficulty, except when dried, in which state their characters under the microscope are not well defined. Crystals which very readily

deliquesce on exposure to air, must be dried in vacuo, removed quickly to a cell, the cover of which must be firmly cemented down at once. Some crystals may, however, be dried and mounted in Canada balsam; others, such as oxalate of lime, cystine, triple phosphate, &c., can be well preserved in aqueous solutions, containing a little acid in the case of the two former substances, or an ammoniacal salt, in the latter instance, in which the crystals are known to be insoluble. Crystals which contain water of crystallisation must be preserved in a drop of the mother-liquor; but in many instances they alter much in form, and when we come to examine them, instead of finding a great number of small, well-formed crystals, as when the preparation was first put up, nothing remains but one or two large ill-shaped ones. The concentrated mother-liquor often acts upon the cement with which the glass cover is fixed on the cell, and very soon air enters, and the preparation is destroyed. Many crystals may be preserved in strong glycerine without much change taking place. I have some crystals of Guinea-pig's blood which have been preserved for many years in this medium and have undergone little change.

*Of the Hardening Properties of Chemical Solutions.*

**317. Of the Hardening Properties of Different Chemical Solutions.**—The consistence of many tissues is so soft that it is absolutely impossible to obtain a thin section; while, by tearing off a small piece, the relations of the component parts is usually so much altered, as to render the specimen useless for the purpose of examination. In this case our only chance is to harden the texture by some reagent in such a manner that, although its microscopical characters are not altered, a thin section may be readily obtained.

The solution employed for hardening a tissue will depend upon the character of the texture itself. Many tissues may be immersed in alcohol, others may with advantage be soaked in a weak solution of chromic acid. Various saline solutions are also sometimes employed, but in consequence of the alteration they produce in the texture of the substance, they are not well adapted for many microscopical specimens. Boiling in water, is often resorted to for the same purpose. In this way very thin sections of such textures as muscular fibre may be obtained. These may afterwards be rendered transparent by being soaked in syrup or glycerine, or by the addition of a little solution of caustic soda or potash; nitric acid and a solution of perchloride of iron have also been employed for hardening some tissues.

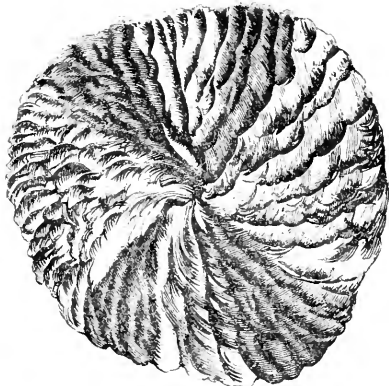
The hardening properties of the solutions just referred to, depend essentially upon their power of coagulating albuminous substances,

Fig. 92.



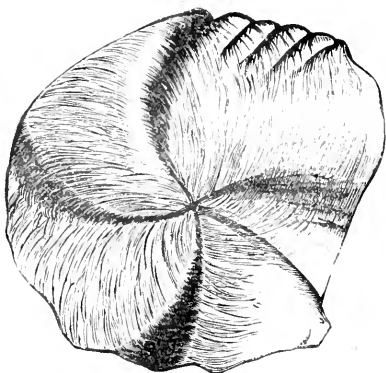
Copper crystalline plate, crystallized at 100°.

FIG. 93.



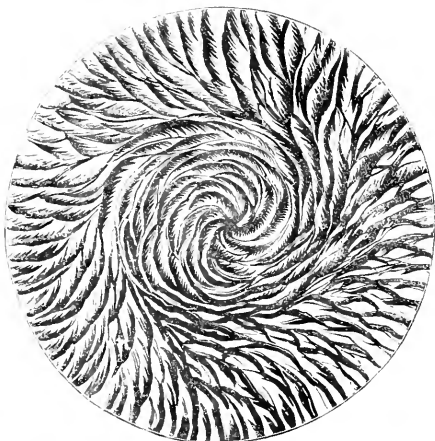
Copper crystalline plate.

Fig. 94.



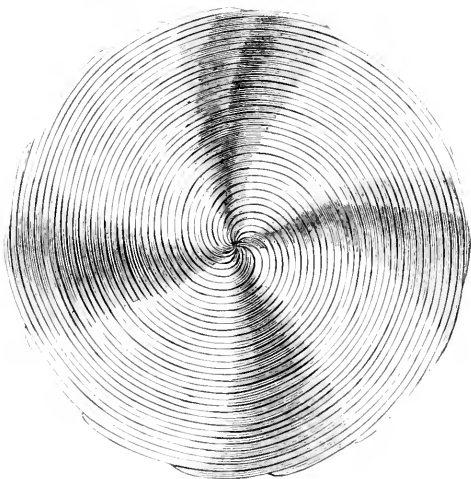
Copper crystalline plate.

Fig. 95.



Copper crystalline plate.

Fig. 96.



The same at 69° at 100°.

Spiral Crystals. Crystalline plate of copper crystallized at different temperatures. p. 215. After Mr Thomas of Oxford. From the *Micr. Journal* July 1860.





Fig. 37.

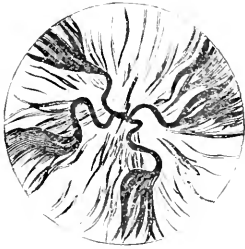


Fig. 38.



Fig. 39.



Fig. 40.

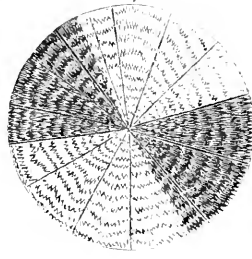


Fig. 41.

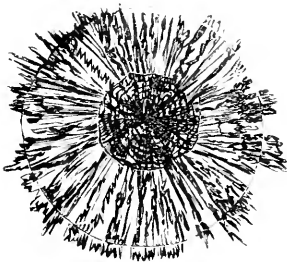


Fig. 416.

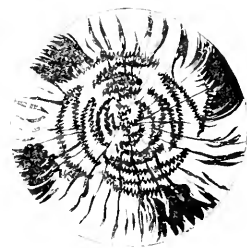


Fig. 417.

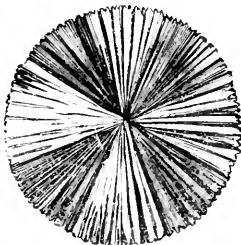
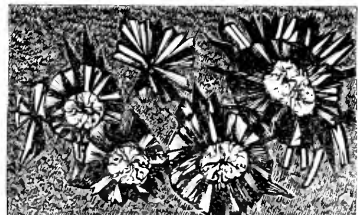


Fig. 418.



Double salt of sulphate of zinc and sulphate of magnesia crystallized at different temperatures from 50° to 17°. The varied effects depend upon the loss of various proportions of water of crystallization. p. 117.  
 After Mr Thomas Mic. Soc. in April 1895.



and in the majority of instances the coagulation is associated with a certain opacity quite incompatible with the satisfactory examination of the tissue by transmitted light, and as I have before hinted, it is absolutely necessary to render such a specimen transparent after the thin section has been obtained, p. 144. It is well to bear in mind that before we can submit many soft structures to microscopical examination, we have to consider what chemical substances are likely to harden them in the most advantageous manner for cutting thin sections, and if by this process the section be made opaque we have further to consider how its natural transparency may be restored. The chemical nature of the substance to be examined, its physical properties, its refractive power, and its chemical composition, are points which it is most desirable that every microscopic observer should be acquainted with before he commences any particular investigation.

I have succeeded in rendering the tissues of the embryos of mammalian animals so transparent that the smallest ossific points can be seen in the temporary cartilages. To dissect these bony points at so early a period, would be a work of immense labour, but by merely soaking the whole organism in the solution, they become beautifully distinct. The embryo is to be immersed in alcohol to which a few drops of solution of soda have been added, and allowed to remain in it for a few days. When the action has taken place, it is to be removed and preserved permanently in weak spirit. I have a beautiful preparation of this kind which has been kept for upwards of ten years. The principle of the action of the fluid may be explained thus:—alcohol alone tends to coagulate albuminous textures and render them opaque, at the same time that it hardens them. The alkali, on the other hand, will render the tissues soft and transparent, and, if time were allowed, would cause their complete solution. These two fluids in conjunction harden the texture and at the same time make it clear and transparent. Many soft tissues may thus be hardened sufficiently to enable us to cut very thin sections. Preparations of this kind show how much may be effected by the use of very ordinary chemical reagents. By this simple process, a minute dissection which would occupy many days is avoided, the chance of losing some of the small ossific points is prevented, while the structures are displayed far more distinctly than they could be by the most careful dissection.

Doubtless there are many other fluids yet to be applied to the purposes of investigation of much greater value than the present one, and I strongly recommend observers to take up this branch of the enquiry and endeavour to discover new modes of preparing textures which shall render their minute structure clearly demonstrable.

## ON SPECTRUM ANALYSIS.

By H. C. SORBY, F.R.S., &amp;c.

**318. The Spectrum Microscope.**—Spectrum analysis, as applied to the microscope, must not be confounded with that branch of the subject which has yielded such admirable results in the hands of Bunsen, Kirchhoff, and other physicists. In that method of analysis it is the number and position of the narrow bright lines or bands, into which the light of the incandescent body is divided by the spectroscop, that enable the experimenter to identify each different substance. It is, in fact, the analysis of the *emitted* light, whereas in spectrum analysis applied to the microscope, it is the analysis of light which has been modified by transmission through the substance under examination, and it is the *absence*, and not the presence, of particular rays which makes the spectra characteristic of different substances. In this respect it is more analogous to spectrum analysis as employed in studying the chemical nature of the atmosphere of the sun or stars, as illustrated by the researches of Kirchhoff, Miller, and Huggins, but the principles involved are materially different. The absorption bands in such cases are narrow, sharply defined lines, characteristic of absorption by gases, whereas those which play such an important part in researches with the spectrum microscope are usually broad, gradually shaded off on each side, and only in a few cases so narrow and sharply defined as to vie with some of the broader dark lines in the solar spectrum.\*

Confining then our attention to spectrum analysis as applied to solid and liquid substances, it may be said that the object of our researches is to distinguish substances by their colour, studied in the most accurate and scientific manner. Colour alone is, of course, often made use of as a criterion in qualitative chemical analysis, and is extremely characteristic of particular substances, even when seen in the ordinary manner; but when more accurately studied by means of the spectroscop it becomes incomparably more characteristic. The colour of a body, as seen with the naked eye, is the general impression made by the whole of the transmitted light, when all the rays are mixed together, and this total impression may be the same, though the compound parts may differ in a striking manner;

\* Though I was the first to publish a paper on spectrum analysis applied to the microscope, after having made use of it in various researches for nearly a year (*Quarterly Journal of Science*, April, 1865, vol. II, p. 198), yet it is only fair to state that Mr. Huggins had independently thought of such an application (*Trans. Microscopical Soc.*, May 10, 1865). [H. C. S.]

and thus many colours which appear almost absolutely alike can be easily distinguished by their spectra. An ordinary spectroscope with small dispersion would suffice to study many of the facts, and even a prism and a narrow slit in a card could be employed; but in order to carry on the enquiries with entire success, it is desirable to have an instrument by means of which spectra of minute quantities of material can be examined, compared side by side with other spectra, and measured with considerable accuracy. All these advantages are secured by means of the spectrum apparatus applied to the microscope, made according to my plan by Mr. John Browning. I have indeed constructed a binocular spectrum microscope which is far more convenient in chemical testing, but is not suited for the examination of any substance less than  $\frac{1}{10}$  of an inch in diameter. I shall therefore confine myself to a description of the single eye-piece arrangement as being the most simple and generally applicable. Fig. 319, pl. L, shows the more important parts of the apparatus. It is an eye-piece, fitting into the tube of the microscope, having the upper lens ( $c$ ) made achromatic. At the focal point of this lens ( $d$ ) is fixed the narrow slit of which fig. 320 gives, as it were, the ground plan; and this can be made broader or narrower by turning the head of the screw ( $a''$ ). A small rectangular prism ( $e$ ) is fixed so as to extend over about one-half of the slit, and reflect the light coming through an aperture at ( $f$ ) in the stage attached to the side of the eye-piece, as shown in fig. 319. The other half of the slit transmits the light passing up the main body of the microscope through the ordinary object-glass. When all is properly arranged and illuminated, in looking through the lens ( $c$ ), a narrow line of light can be seen, one-half the length of which has passed through an object placed on the stage of the microscope, and the other half through any other placed on the side stage attached to the eye-piece; and, if the prism ( $e$ ) has been properly adjusted, these two portions should appear perfectly continuous, without any break at their junction; but if not properly adjusted the line appears broken, and would then give false results if the spectra were compared together. Care should therefore be taken to see that the adjustment is correct. The analysing prism ( $a b$ ) is compound, and fits over the eye-piece like a long cap. It consists of two rectangular prisms of flint glass, corrected for refraction by one rectangular prism of crown glass, and two others, with angles of about  $75^\circ$ . This combination gives direct vision, and an amount of dispersion which is admirably fitted for the purpose to which this instrument is applied; since it is sufficient to divide all the absorption bands seen in coloured solids and liquids, and is not

so great as to spread them over too wide a space and make them very obscure, as is the case when the dispersion is great. Since the light which passes through the opening at ( $f$ ) is not spread out over the same surface as that which passes through the object-glass, it would be far too bright, unless modified by means of a small shutter, opening and shutting with a screw. In each case this can be easily adjusted, so that the light from the two sources is equal, or may be made to vary for some special purpose. There is also a contrivance shown in fig. 320, which enables us to limit the length of the slit; so that when very small objects are examined, no light shall pass except that which has come through them.

In using the spectroscope, a great deal depends on the slit being made up of a proper width. If the light be strong, it is best to have the slit only opened so much as to give a good clear spectrum, free from the irregular shading, due to unavoidable irregularities in the slit itself, which may be very conspicuous if the slit be very narrow. If day light be employed, and it is only rather feeble, the slit should be made wider, so as to admit more light; but then, if made too wide, the colours of the spectrum lap over one another, and become indefinite. Much, however, should depend on the nature of the object under examination; and, if it gives rise to very narrow absorption bands, the slit should be made narrow in order to give good definition. As a general rule the slit should be of such a width as to just indistinctly show the Fraunhofer lines in day light. It is also important to properly adjust the small slit under the side stage attached to the eye-piece. It should generally be made of such a width that the two spectra are of equal brilliancy, since otherwise the comparison would be inaccurate.

It is in all cases most important that no light should pass up the microscope, that has not actually passed *through* the substance under examination. If the object is small, unmodified light passes on each side, and this is reflected from the front of the object-glass down on the object and back again through the lenses without traversing its substance; and thus an entirely false spectrum may be obtained, especially if the substance is dark coloured. This can easily be avoided by having a tube to fit over the object-glass, *see* fig. 324, which has a stop at the end with a hole in the centre ( $a$ ), of such a width as not to limit the field of the microscope, placed at such a distance as to be within the focal length, so as to approach but not to touch the object when it is in focus. For a  $1\frac{1}{2}$ -inch object-glass the opening should be about  $\frac{1}{16}$  inch. Such a stop is also very useful in ordinary microscopical observations, when it is desirable to have no reflected light, and shows incomparably better the true colour of dark objects.

Having said so much with reference to the instrument, it will be well to describe the manner of preparing and viewing the objects; and this will be better understood if we first consider some of the general principles involved in this branch of research.

### 319. Of Examining Objects in the Spectrum Microscope.—

Having properly arranged the instrument, if nothing intervenes to interfere with the white light employed for illumination, of course a simple and continuous spectrum is seen, with all the colours from the extreme red to the extreme blues and lavender; and, if a perfectly colourless and transparent substance be placed in front of the object-glass, no effect whatever is produced, and thus so to speak, all colourless bodies give the same spectrum and cannot be distinguished by means of their spectra. Coloured bodies are, however, those which are, as it were, black and opaque for certain rays, not allowing them to pass forward as light, but probably transforming them into heat or some other kind of force; and on placing such a substance in front of the instrument its presence is shown, not by the light which is still transmitted, but by that which it *cuts off*. It is, therefore, more simple and accurate to take into consideration the characters of the *absorbed* than of the *transmitted* rays, and in fact, the whole subject of qualitative analysis by means of the spectrum microscope, is founded on the relation between different substances and particular rays of the spectrum which they absorb, or so alter that they no longer pass forward as light. Unfortunately, it is not every substance which gives such a spectrum that its true nature can be recognised at once, but many are of such a character that they could not be confounded with any other yet known. These are those which absorb the light in narrow and well-defined portions of the spectrum, so as to give spectra with one or more definite black bands. The number, position, width, and intensity of these *absorption bands* are the most important data on which to form an opinion respecting the nature of the substance under examination. It must not be thought that these bands bear any relation to the elementary constituents of the substance—they are merely related to it as a definite compound in a particular physical condition, and may vary according to its state. For example, they often vary for the same substance, when solid or in solution; and even according to the nature of the solvent, besides being greatly modified by the presence of free acids or alkalis.

Fig. 321, pl. L, gives a few spectra, to illustrate the general subject. They are all of red or pink colours.

A is an indefinite spectrum, yielded by very many different substances, having a general absorption over the green, with no narrow absorption band.

B is the spectrum of a solution of logwood in water, to which bicarbonate of ammonia has been added, and C is the same in the case of Brazil wood; and the difference between the two is shown by the different position of a single well-defined absorption band.

D is the spectrum of fresh blood.

E is the spectrum of alkanet root in alum with a little alcohol.

F is the spectrum of deoxidised ammoniacal hæmatine.

These three show very well how closely related spectra may be easily distinguished by the different position and relative width and darkness of the bands.

Many coloured substances give spectra which do not enable us to decide with confidence what they are. Perhaps some half dozen substances may be known which would give the same result, and this spectrum may only serve to indicate to what group the colour belongs; but even then, supposing it be a solution, the addition of some reagent may at once show which particular substance is present. For example solutions of Magenta and Brazil wood both give a single well-defined absorption band in the same position, in the upper part of the green, but ammonia produces no change in Magenta, and great change in the Brazil wood. Sulphate of soda then immediately makes the Magenta colourless, but does not change the Brazil wood except by gradual fading and decomposition. It is, however, extremely difficult to distinguish some substances, especially when mixed with other colours; but still by suitable methods many can be recognised without difficulty under most unpromising conditions. This, however, is more a question for a treatise on qualitative analysis by means of the spectrum microscope, than for one on the instrument itself and the manner of using it.

It must not be thought that an indefinite quantity of any substance will give a characteristic result. If too little is present, nothing definite can be seen; and, if there is too much, the most characteristic parts of the spectrum may be entirely obscured. For example fresh blood gives two remarkably well-defined absorption bands in the upper part of the green; but, if too little is present, these bands are very faint, and, if too much is present, all the light is absorbed, except the red and orange, so that the bands cannot be seen at all. In every case a certain amount of colour gives the best result; and though at first this may appear difficult to arrange, yet after a little experience there is really no difficulty, especially if we make use of such small cells as are shown in fig. 322. These are cut from barometer tubes; and I find that the most convenient



sizes are  $\frac{1}{2}$ -inch long,  $\frac{1}{4}$ th inch in internal, and somewhat under  $\frac{1}{2}$  inch in external, diameter. These are ground flat at each end and attached with Canada balsam near one edge of a glass plate, so that they may be examined either end-ways, by laying the plate flat on the stage of the microscope, or side-ways, by leaning the glass against the side of the object-glass. If then the colour is too deep in the line of the length, the tube can be turned, so that it may be examined side-ways, which being equivalent to using  $\frac{1}{4}$ th the quantity, we can easily judge what amount would show the most perfect spectrum. The cells should be either filled level, or covered with a piece of thin glass. If the diameter of these cells be less than  $\frac{1}{4}$ th of an inch, it is difficult to fill and empty them; and, if much wider than  $\frac{1}{8}$ th, the liquid is apt to run out when they are turned over; but when of about  $\frac{1}{4}$ th wide they are easily filled and not a drop of liquid is lost even when they are turned upside down. Almost all kinds of testing can be carried on in these cells, and they may be easily washed out by means of a small stream of water blown out of an ordinary chemical wash-bottle, pl. XXII, fig. 143. Solid or liquid reagents can easily be added and stirred up by means of a moderately stout platinum wire, flattened at one end, and turned up square like a small hoe. The great advantage of these cells is that a very small quantity of material is required (which is most important in some investigations); but for some purposes ordinary test-tubes are very useful, and especially to place on the stage attached to the eye-piece and compare with objects on the stage of the microscope. These can be examined only at the sides and the colour must, therefore, be diluted so as to show the best spectrum. Wedge-shaped cells like fig. 325, are also useful in order to study the effects of different thicknesses of solutions. Colours which do not materially change on keeping some time may be mounted in tubes, *see* fig. 326, about  $\frac{1}{2}$ -inch in diameter and 3 inches long, sealed up flat at the bottom, and drawn out capillary at its top, leaving a small opening through which the liquid may be introduced by means of an air pump, afterwards sealed up with the blow pipe. Many mineral salts can thus be kept for an indefinite period; and even many animal and vegetable colours can be kept for a year or more always ready for examination.

### 320. Examination of Blow-pipe Beads and Solutions in Cells.—

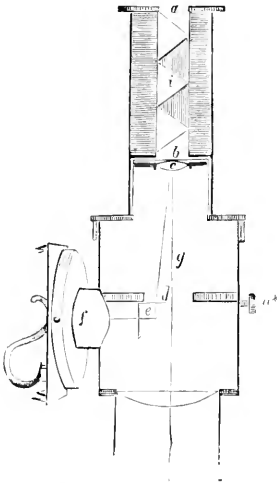
The coloured beads obtained by ordinary blow-pipe testing, can easily be examined by the spectrum microscope; and in some cases, give very satisfactory results. Some crystals also are excellent objects, and give striking spectra. It is easy to select such as give the best result, or to cut them wedge-shaped, and thus examine

the effect of different thicknesses. Coloured glasses cut wedge-shaped are also very interesting, and are useful to compare with blow-pipe beads ; but for actual research, no branch of the subject is so satisfactory, as the testing of minute quantities of animal and vegetable substances in the small cells. This includes the detection of blood-stains, which can be done with great ease and certainty (Quart. Journ. of Science, vol. II, p. 198) ; the detection of adulteration in drugs and other substances met with in commerce ; and the determination of the identity of, or the difference between, the very numerous colouring matters met with in plants. In a number of such practical questions, special methods may be employed with advantage ; but in examining an unknown colouring matter, it is well to adopt a definite system, so as to be able to decide to what particular group it belongs. After a large number of experiments, I found that it is easy to arrange them in divisions founded on their solubility in water or alcohol. Thus—

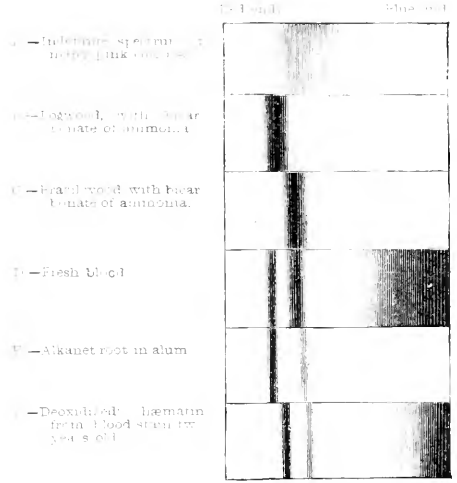
		Division.
Soluble in water and not precipitated by alcohol	...	1
Soluble in water but precipitated by alcohol	...	2
Insoluble in water but soluble in alcohol	... ..	3
Insoluble in water and alcohol	... ..	4

Then we may divide 1, 2, and 3, into groups, founded on the action of sulphite of soda. The effect of this reagent is very remarkably related to the spectra. If the absorption extends from the blue end continuously, it produces no change, but if there is a detached absorption in the green or yellow separated from the blue end by a more transparent space, the sulphite in certain groups of colours removes this, and leaves the absorption in the blue unchanged. In some colouring matters this occurs in an ammoniacal solution, and these constitute my group A. In others, no such change takes place unless the solution be strongly acid, and these form my group B. This is usually quite independent of decomposition, and the colour is restored by the addition of ammonia. Those colours which are not immediately altered when the solution is acid, constitute my group C. By these reactions, mixtures of colours of the different groups can easily be recognised ; and this alone may often be of great practical use. Then, in order to divide these into sub-groups, I have recourse to the number of distinct absorption bands, when the neutral colour is dissolved in water or alcohol, or when ammonia is added to each. By this means we obtain a large number of sub-groups, which are of great use in practical researches. It would extend this account to an unreasonable length, if I were to

Fig. 314.

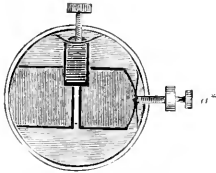


Wheeler's spectrum apparatus for the microscope, with arrangement for producing two spectra for comparison. p. 219.



Absorption bands produced by different substances. p. 219.

Fig. 316.



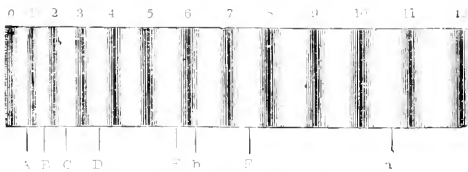
Arrangement for changing the length and breadth of the spectrum. p. 219.

Fig. 317.



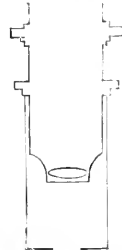
Cell for examining solutions by the spectrum microscope. Half the real size. p. 219.

Fig. 318.



Scale for measuring the exact position of the absorption bands. p. 219.

Fig. 319.



Glass tube for examining solutions by the spectrum microscope. Half the real size. p. 219.

Fig. 325.



Wedge-shaped cell for examining solutions in the spectrum microscope. p. 220.

Fig. 326.



Glass slide for examining solutions by the spectrum microscope. Half the real size. p. 220.



describe this subject in full detail, and therefore will refer to my paper in the Proceedings of the Royal Society (1867, vol. XV, p. 433) for a complete account of the general method, and of those laws which indicate the presence of one or more colouring matters in a solution.

**321. Method of Measuring the Position of Absorption Bands.**—

In order to measure the exact position of absorption bands, &c., seen in spectra, I have contrived a small apparatus, which gives an interference spectrum, divided by black bands into 12 parts, all of equal optical value. It is composed of two Nicol's prisms, with an intervening plate of quartz, about  $\cdot 043$  inch thick, cut parallel to the principal axis of the crystal, the thickness being so adjusted, that the sodium line is exactly at  $3\frac{1}{2}$ , counting the bands from the red end towards the blue. I have placed such standards in the hands of Mr. Browning, and Messrs. Beck, who have undertaken to prepare others like them.

The characters of this scale will be better understood from fig. 323, pl. L.

In the spectrum microscope this spectrum is, as it were, in direct contact with that under observation, and the position of any absorption can be easily measured to within  $\frac{1}{1000}$ th part of the width of the whole spectrum. Such a system of measurement enables us to adopt a method by means of which spectra can be easily described in notes, or printed by means of ordinary types. In order to express the intensity of absorption, I make use of the following symbols:—

Not at all shaded	Blank space.
Very slightly shaded	. . . Dots with wide spaces.
Decidedly shaded	. . . Dots closer together.
More shaded	.... Very close dots.
Strongly shaded, but so that a trace of colour is still seen	} . . . Three hyphens close.
Still darker	— Single dash.
Nearly black	—— Double dash.

Except when specially requisite, only the symbols . . . - - - — are employed for the sake of simplicity, and then as signs of the relative, rather than of the absolute, amount of absorption; and it is assumed that there is a gradual shading off from one tint to the other, unless the contrary is expressed. This is done by means of a small vertical line over the figure (*see* No. 111, p. 227) which shows that there is a well-marked division between them. Definite narrow absorption bands are indicated by \* printed over their centre. This

will be better understood by a description of the spectrum of de oxidised hematin.

Clear Red, Orange, and Yellow;	Very dark band.	Clear Green.	Much less dark band.	Clear Green and Blue.	Gradually shaded to very dark at the extreme blue end.
$4\frac{1}{2}^* - 5$			$5\frac{1}{2}^* - 6\frac{1}{2}$		$9 \dots 10 \dots 11 -$

The following examples will show how simple or more complicated spectra may thus readily be printed and compared. I have chosen solutions of similar tint, in order to show that the spectra of those of nearly the same colour may be very different, or, if analogous, may differ in details, easily expressed by the symbols. The colour of each is given after the name. Nos. 1, 8, 9, 10, 11, 12, and 13 can be kept for a long time, sealed up in tubes, and the rest are easily prepared. In each case the spectra are those seen with solutions of such a strength as gives the most decided results, and shows the presence or absence of absorption bands to the greatest advantage.

1. Cudbear in alum	<i>(Pink)</i>	$3 \dots \dots S \quad 11 -$
2. Colour of elder berries with citric acid.	<i>(Red Pink)</i>	$4 \dots 5\frac{1}{2} - S \dots 9 \dots 11 -$
3. Brazil wood, with bicarbonate of ammonia.	<i>(Pink)</i>	$4\frac{1}{2}^* - 5\frac{3}{4} \dots \dots S$
4. Logwood, with bicarbonate of ammonia.	<i>(Pink)</i>	$3\frac{5}{8}^* - 5\frac{1}{4} \dots \dots 7$

The next four are spectra of blood, produced by the successive addition of the various reagents, as in detecting fresh stains.

5. Fresh blood.	<i>(Pale Scarlet)</i>	$3\frac{1}{2}^* - 4\frac{3}{8} \quad 4\frac{3}{4}^* - 5\frac{3}{4} \quad 7 \dots 8 \dots 9 -$
6. Citric acid then added.	<i>(Pale Brown)</i>	$1\frac{5}{8} \dots 2\frac{1}{4} \quad 4 \dots 8 \dots 9 \dots 10 -$
7. Ammonia then added.	<i>(Pale Brown)</i>	$3\frac{7}{8} \dots 4\frac{3}{4}^* \quad 4\frac{1}{2} \dots 5\frac{1}{2}^* \quad 7 \dots 8 \dots 10 -$
8. Deoxidised hematin, from blood stain 2 yrs. old.	<i>(Pink)</i>	$4\frac{1}{2}^* - 5 \quad 5\frac{1}{2} \dots 6\frac{3}{8} \quad 9 \dots 10 \dots 11 -$

With these may be compared the two spectra which more nearly resemble those produced by blood than any I have yet seen.

9. Cochineal in alum. (Pink)  $3\frac{3}{8}^* - 4\frac{1}{2} \dots 5\frac{1}{8}^* \dots 6\frac{1}{8} \dots 7^1$
10. Alkanet root in alum. (Pink)  $3\frac{1}{2}^* - 4\frac{3}{8} 5\frac{1}{4}^* \dots 5\frac{3}{4}$

The following spectra of compounds derived from chlorophyll, are as complicated as any I have met with.

11. Normal chlorophyll }  
in alcohol. (Deep Green) }  $\frac{7}{8}^* - 2\frac{1}{8} \dots 3\frac{1}{4} \dots 4\frac{1}{2} 6\frac{3}{8} \dots 7\frac{1}{2} -$
12. Ditto, as decom- }  
posed by acids, or }  
as found in some }  
leaves. (Olive Green) }  $1 - 2\frac{1}{8}^* 2\frac{3}{8}^* \dots 3\frac{3}{8} 4\frac{1}{4} \dots 5\frac{1}{4} - 5\frac{3}{4} \dots 6\frac{3}{8}^* \dots 7\frac{3}{8} 8\frac{1}{2} \dots 9\frac{1}{2} -$
13. Ditto, as decom- }  
posed by caustic }  
potash, and then }  
by hydrochloric }  
acid. (Red-Green, Neu- }  
tral Tint) }  $\frac{1}{4}^* - \frac{3}{4} 1\frac{1}{8}^* - 1\frac{3}{8} 1\frac{7}{8}^* - 2\frac{1}{8} 4\frac{1}{2}^* \dots 5\frac{1}{4} \dots 9 \dots 10 -$

In many cases the position of the centre of the absorption bands is very characteristic of the different substances, and we may easily express their differences by writing the division, group, sub-group, and position of the bands, in the following manner:—

- Purple pansy 1,A,aq<sub>0</sub> am<sub>1</sub> (4).  
Brazil wood 1,C,aq<sub>1</sub> (5 $\frac{1}{4}$ ).  
Logwood 1,C,aq<sub>1</sub> (4 $\frac{3}{8}$ ).

These signify that the colour of the purple pansy is soluble in water and not precipitated by alcohol—that sulphite of soda removes the absorption band when added to the ammoniacal solution—that there is no absorption band in the neutral solution, but that on adding ammonia a single absorption band is developed, whose centre is at 4. In the case of Brazil wood and logwood, they signify that the colour is also soluble in water and not precipitated by alcohol—that sulphite of soda has no action on either an acid or alkaline solution—that in each there is a single absorption band in the neutral aqueous solution, situated in different positions in the two colours, as shown by fig. 321, B and C.

I trust that this brief description will show that in practical working a great deal may be easily expressed by very simple symbols. We may soon decide to which group and sub-group any colour belongs; and, if we had a table of various known colours, arranged

according to these principles, we might often soon ascertain its true nature. Of course there are many points requiring special attention, which, as already remarked, more strictly belong to chemistry than to a work on the microscope; and therefore I have confined myself merely to an account of some of the leading principles involved in this method of qualitative analysis.

**322. Substances giving well-marked Absorption Bands.**—The following is a list of some objects, giving more or less well-marked absorption bands, which can easily be prepared for examination:—

*To be examined at once, not keeping well when diluted.*

Blood in water.

Magenta, in water or alcohol.

Mauve in alcohol.

Aniline blue in alcohol.

Brazil wood in water alone, and with bicarbonate of ammonia.

Logwood ditto ditto.

Blue Lobelia flowers in water.

*Keeping well for many months.*

Deoxidised ammoniacal hæmatin in water.

Alkanet root in alcohol, with a little acetic acid.

Alkanet root in alum, with a little alcohol.

Colour of red Cineraria flowers in syrup.

Cochineal in water.

Cochineal in alum.

Chlorophyll in alcohol.

Chlorophyll in alcohol, with a little hydrochloric acid.

*Keeping well, probably for an indefinitely long time.*

Permanganate of potash in water, sealed up in a tube of glass which contains no lead.

Urano-uranic sulphate in water.

Chloride of cobalt in water.

Chloride of cobalt in a strong aqueous solution of chloride of calcium.

Chloride of cobalt in absolute alcohol.

Crystals of binoxalate of chromium and potash.

„ perchlorate of potash coloured with a little permanganate of potash.

„ native phosphate of uranium.

„ acetate of uranium.

„ chloride of cobalt.

„ binoxalate or chromium and soda.



## PART IV.

ON TAKING PHOTOGRAPHS OF MICROSCOPIC OBJECTS.—APPARATUS.  
—ILLUMINATION.—CHEMICAL SOLUTIONS.—PRACTICAL MANIPULATION.—PRINTING.—PHOTOGRAPHS FOR THE MAGIC LANTERN.

SINCE the last edition of this work was published in August, 1864, some valuable improvements have been introduced in the method of taking microscopical photographs, and it seems probable that before very long far greater perfection in the results will be obtained than was supposed to be possible at that time. My friend, Dr. Maddox, has continued his experimental investigations and with continually increasing success; and many observers in Germany and France, as well as in this country, have produced beautiful photographs of various kinds of objects. But perhaps the most remarkable advances have been made in America. The authorities in the War Department recognising at once the high importance of photographic representations of microscopical specimens have issued a report in which will be found the results of the researches of Brevet Lieut.-Colonel Dr. J. J. Woodward and Brevet Major Dr. F. Curtis. This report is most admirable. The drawings are beautifully executed, the paper well adapted for them, and the printing excellent, contrasting remarkably in all these points with the rough looking blue books issued under the authority of our Government.

It seems to me very hard that our statesmen do not more distinctly indicate that they fully appreciate the high importance of purely scientific investigation than has been the custom hitherto, and our Government clearly ought to take a very active part in advancing new methods of enquiry, particularly in connection with naval and military medicine and surgery. In the medical department of our army and navy there are to my knowledge scientific men as able and as willing to devote themselves to scientific work as any in the world, but they have no opportunity, and little or no encouragement seems to be afforded by the high military authorities. I append an extract from p. 149, Circular No. 6, Nov. 1865, War Department, Surgeon-General's Office, Washington, and hope that it may perchance

be brought under the notice of some of those who alone have power to forward or obstruct scientific progress in the departments under Government control.\*

“With low powers no serious obstacle was encountered in obtaining excellent photographs of properly selected preparations. The higher powers offered difficulties most of which however have been overcome. In experimenting with the higher powers, the lined diatomacæ were selected as test objects on account of their definite and well-known structure. With these the utmost success has been realised. A photograph of *Gyrosigma angulatum* (*Navicula angulata*) has been obtained, for example, magnified about 7,000 diameters in which the hexagons appear of the same size and nearly as distinct as in the cut, which was made by transferring to wood a tracing from the original photograph. In fact, any of the markings on the diatoms that are visible with the microscope can be photographed with the utmost clearness and ease, and the time has arrived when the inability to photograph alleged markings will throw doubts on the correctness of the observers who have supposed they saw them. The plan employed in the photographic work hitherto executed with high powers is as follows: The direct rays of the sun reflected in a constant direction from the mirror of a Silbermann’s heliostat (loaned for the purpose by the Coast Survey), are condensed by a large lens upon the plane mirror of the microscope, whence they are reflected through the achromatic condenser in the usual way. Before reaching the achromatic condenser, however, the rays pass through a cell containing a solution of the ammonio-sulphate of copper of sufficient density to absorb nearly all the rays except those at the violet end of the spectrum. The light used, therefore, is essentially monochromatic, and contains, with enough illumination for agreeable vision, the greater part of the actinic force of the sun’s rays. The heating rays being chiefly at the other extremity of the spectrum are of course excluded and great actinic force is obtained, therefore, without any danger to the preparations, or the balsam cementing of the object-glasses. The object-glass employed in the photograph of *Gyrosigma*

\* I believe that it would be most difficult, if not actually impossible for our Government at this time to issue a report of the character of that from which the extract is taken, supposing that the actual work had been done by private persons and placed at the disposal of the State. The paper of our Blue Books is too coarse, and the printing too rough for scientific memoirs. Let the reader, for instance, compare the plates accompanying my report on the Cattle Plague, which were printed by Government, with those in the present work. The contrast between the text of Government and private works is still more striking.

above alluded to was a one-eighth of an inch, by W. Wales and Co., of Fort Lee, New Jersey. This glass is so constructed as to bring the actinic rays to a focus. At the bottom of the draw tube was placed an achromatic concave lens—the amplifier of Tolles (of Canastota, N. Y.), and an ordinary medium eye-piece completed the optical apparatus. The eye-piece extremity of the microscope was thrust into one end of a long camera-box, the connection made light-tight by means of a black silk hood, and the image received on a piece of plate glass, observed by means of a focussing glass, while the focal adjustments were made. As with the very long camera used, the arm of the observer cannot reach the milled head of the fine adjustment of the microscope, this head was grooved, and connected by a band with a grooved wheel at the end of a long steel rod, the other extremity of which is near the observer, who, by means of it, can focus accurately with any required length of camera. There is nothing peculiar in the chemicals employed, and with ordinary collodion, and the high power above spoken of, from thirty to forty seconds exposure was quite sufficient. Of the foregoing devices most importance is to be attached to the employment of monochromatic light (the violet end of the spectrum), and the use of an object-glass constructed with special reference to the actinic rays. Both these points were suggested to me by Mr. L. W. Rutherford, of New York, so well known by his connection with telescopic photography, who has thought much, and made many satisfactory experiments in this direction. I believe, however, that the apparatus as above described, loses some of its advantages by the use of the eye-piece which I propose to substitute by a lens of proper magnifying power, corrected, like the object-glass, in such a way as to bring to a focus the actinic rays. Such a lens is now in process of construction for further experiment. The pathological photographs hitherto satisfactorily executed in the Museum have chiefly been made with moderate magnifying powers, twelve to fifty diameters, though some experiments with high powers justify me in the belief that with the improvements above described, all that is desired in this direction can be attained. Among these experiments I may particularly mention a view magnified about four hundred diameters, of the polygonal cells and flat cholesterin tables of a cholesteatoma, which was found on the inner surface of the frontal bone of a soldier who died of epilepsy in the neighbourhood of Washington.”

Such an extract is enough to show the activity and usefulness of the department by which it is issued, and is in the highest degree creditable to those who performed the work, and to the Government which sanctioned and encouraged its prosecution.

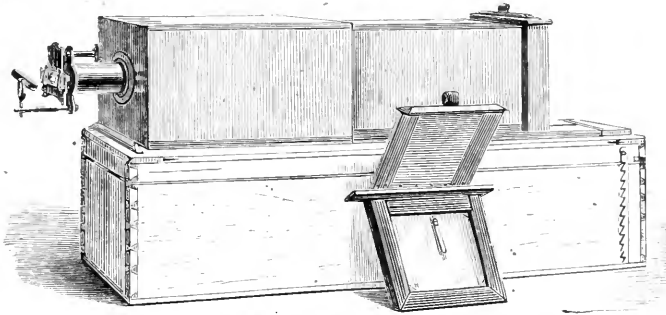
### 323. History of the Application of Photography to the Microscope.\*

- Mr. Dancer, about 1840, produced photographs of microscopic objects by the *gas microscope*, the images being taken upon silvered plates; also images of sections of wood, fossils, &c., were reproduced on paper and glass plates by means of the solar microscope. In 1841, Mr. Richard Hodgson obtained excellent daguerreotypes of microscopic objects. The Rev. Messrs. Reade and Kingsley were early authorities in the employment of photography in this manner; also Mr. Talbot. Dr. Donné, of Paris, in 1840, presented to the Academy of Sciences copies of various microscopic objects on daguerreotype plates; and in 1845, conjointly with M. Léon Foucault, published an Atlas of Microscopic Anatomy, in which the engravings were printed from daguerreotype plates, which after exposure and development had been chemically etched. The delicacy of these illustrations was very marked, but the plates permitted comparatively few impressions to be struck off before giving evidence of injury.

In October, 1852, a paper by Mr. Joseph Delves was presented to the Microscopical Society of London, and in the following number of the "Quarterly Journal of Microscopical Science," some beautiful specimens of prints from Mr. Delves' collodion negatives were issued by the then publisher, Mr. Highley. This was one of the earliest publications in this country with photographic illustrations of microscopic specimens. In the same journal is a valuable contribution by Mr. G. Shadbolt. Since that period the employment of photography in this way has become general; doubtless many have been occupied with it whose names are not familiar to us. In Paris M. Nacet and M. Bertsch have obtained excellent results. In Germany, Gerlach, Albert, Mayer, Kolmann of Munich, Helwig of Mayence, and many others have illustrated memoirs with photographic plates. Sir D. Brewster, in his article Microscope, "Encyclopædia Britannica," last edition, speaks very highly of some photomicrographs exhibited at the Academy of Sciences, Paris, in 1857, by M. Bertsch, the focal length of the objective used being half a millimetre. The objects, a diatom from guano magnified 500 diam.; two specimens of navicula, one  $\times 800$ , the other  $\times 500$ , the field being rendered nearly dark by oblique illumination; human blood globules  $\times 500$ ; and two pictures of salicine, one taken by polarised light. M. Hartnach, Sir D. Brewster says, has constructed a complete instrument for M. Bertsch, the range being from 50 to 1,000 diameters, and from 50 to 150 diameters for opaque objects.

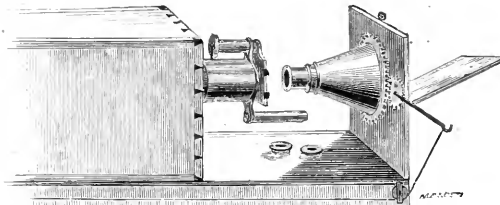
\* The sections in this part of the work have been carefully revised by Dr. Maddox, who has kindly added much new matter of great importance, especially in §§ 327, 332, 338, *et seq.*

Fig. 327.



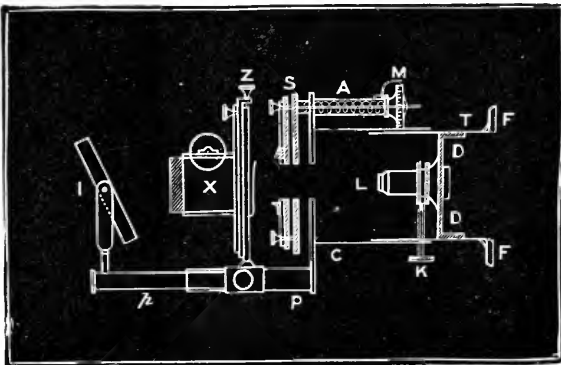
Photographic microscope camera used by Mr. DeLves, arranged by Mr. Highley p. 135.

Fig. 328.



Stage-mirror condenser with adjustment to fit on the end of the above camera (Fig. 327) as improved by Mr. Highley. p. 136.

Fig. 329.



Another arrangement showing the object glass, stage, fine adjustment, &c., with mirror and condenser. Mr. Highley. p. 236.



The extreme detail, beauty of texture, and sharp delineation of the objects in the prints from Mr. Delves' negatives marked a very important step. The frontispiece to this work was obtained by Dr. Maddox in the following manner, as described in a note to me :—

“Prints selected from some of my negatives, representing objects magnified in various degrees, varying from the  $1\frac{1}{2}$  inch objective to the  $\frac{1}{12}$ th, were placed on a card in such a manner as to try to balance each other in their effects, and such size of card adopted that, when reduced *one-half*, it might correspond with the dimensions chosen by yourself for the plate. The card of prints being placed at the requisite distance, a Ross' 15-inch focus landscape lens was used to obtain the negative copies.

“To render the minutest line, especially in the *Pleurosigma angulatum*, well evident in the negative, it was necessary not to carry the development or intensifying process too far, or these became filled up and much obscured, hence the interspaces between the figures allowed a little light to pass; as this seemed detrimental and rendered the figures less effective in appearance, these parts have been painted out.

“The illustrations were photographed with the objective stated in the ‘explanation.’ The  $\frac{1}{12}$ th objective was made by Mr. Wenham, and through his liberality placed at my service.”

Many of these photographs require a magnifying glass to bring out their detail.

My friend Dr. Dean, of Boston, U.S., sent me some very perfect photographs of sections of the medulla oblongata, taken with the low powers. These are by far the most perfect photographic illustrations of structures from the higher animals that I have seen. (“The Grey Substance of the Medulla Oblongata and Trapezium,” by John Dean, M.D., *Smithsonian Contributions to Knowledge*, 173. Washington, 1864.) These photographs were also successfully printed by photolithography. Dr. Duchenne, of Boulogne, also obtained some very successful results with anatomical structures, and M. Rouget has employed the same means in the ordinary way and stereoscopically, to illustrate some of his views in minute structure.

In 1865, Dr. A. Helwig, of Mayence, published his work on the Crystalline Forms of Alkaloids, and their Sublimates, &c., illustrated by a large number of photomicrographs. Dr. Moitessier has also adorned his book on photomicrography, “*La Photographie Appliquée aux Recherches Micrographiques*, 1866,” with three photograph plates of various objects.

Dr. Draper, of America, employed for many of the plates in his

work on Anatomy and Physiology woodcuts from photographs of the microscopic objects, and Dr. Herapath, of Bristol, adopted a similar method for his paper on the Spicules and Plates of Synapta, published in the Quarterly Journal Mic. Science.

Photography has been used by Dr. Maddox to illustrate a paper presented to the Royal Society, June, 1867; the photographs being made from an aquatic Larva whilst living.

Many anatomical specimens, however, cannot be copied by photography, especially if they be very thick. The yellow colour of the tissue in most instances precludes the possibility of making a photograph of it, as the transmission of the light is so much interfered with; and this is an especial objection in the case of injections viewed as transparent objects, for the tissue intervening between the vessels is often so yellow that these intervals in the photograph become as dark as the vessels themselves. My friend Dr. Julius Pollock has nevertheless succeeded in obtaining for me some very tolerable copies of injections of the distribution of the ducts in the liver. By practice, doubtless, many improvements in the process of taking photographs of such microscopic objects would be effected.

When only few copies of a work are required, the researches may be very cheaply illustrated by taking photographs of drawings. A large drawing of the object must first be made in the manner described in p. 27. From this a negative reduced to the proper size is taken, from which any number of copies may be obtained. In this manner I have illustrated my memoir on the anatomy of the liver, with upwards of sixty illustrations (The Anatomy of the Liver, 1856). The results were not so satisfactory as they might have been, but as all these prints were prepared at home with very limited appliances, very good prints could not be looked for. When many copies of a work are likely to be required, this mode of illustration is not applicable, as the original cost of engraving would soon be covered; but when only a *few* copies of a *great number* of drawings are wanted, this plan possesses decided advantages.

From the great success of Mr. Walter Woodbury's and Mr. Swan's process of carbon printing, and the facility with which large numbers of prints can be produced, there seems every chance that the cost of illustration will be materially lessened, and greater permanence secured.

**324. Illumination.**—Different modes of illumination have been employed. Mr. Delves has used sunlight. Mr. Shadbolt, in 1852, tried some experiments with artificial light, and succeeded satisfactorily with a small camphine lamp. Mr. G. Busk employed gaslight from an argand burner in 1854; and in November of the same year Mr. Wenham states that, although with the use of camphine



and gaslight he was dissatisfied, yet the succession of electric sparks (about 100), from a small Leyden jar of 30 inches coated surface, gave actinic rays of sufficient intensity to produce a good impression on a sensitive collodion plate. Mr. Wenham, however, upon the whole gave the preference to sunlight. Mr. Howlett also used sunlight, and condensed it from a plane mirror or solar reflector by a six-inch double convex lens. The Rev. Mr. Kingsley with a special apparatus used the hydro-oxygen light and a screen of esculine. Mr. Bockett, in 1862, tried diffused daylight, allowing in some cases an exposure of from four to eight minutes. Dr. Maddox, in 1864, succeeded, by using the brilliant light emitted on the combustion of magnesium wire ( $1\frac{1}{4}$  inch) held in the flame of a small spirit lamp, and condensed by an ordinary condensing lens. Mr. Durham also now uses gas and daylight illumination very successfully.

#### APPARATUS.

Two modes of arranging the apparatus have been devised. In the first, the ordinary compound microscope is placed horizontally in connection with an ordinary camera by inserting the eye-piece end (the eye-piece being removed) into the brass setting of a well-made portrait combination (the lenses having been removed), and the aperture around the body of the microscope perfectly closed by any simple method, as a card cap or cone of black cloth or velvet attached to both.

In the second, the ordinary microscope is dispensed with, the objective, stage, and mirror being adapted to the front of a well-made camera in the place of the usual combination; proper arrangements being made for holding the object, supporting the mirror, and adjusting the different special parts. The pocket microscope described in p. 14, may be adapted to the camera.

**325. Camera with Object-Glasses and Stage adapted to it.**—The apparatus used by Mr. Delves was brought before the public by Mr. Highley, and very much perfected by him. This form of apparatus attracted considerable attention at the late International Exhibition. M. Duboscq also exhibited this arrangement. It seems to meet most requirements for moderate distances, but demands especial outlay. Mr. Highley has lately introduced further improvements, which make his apparatus still more perfect. *See* pl. LI, fig. 329.

**326. Mr. Wenham's Arrangements without a Camera.**—Mr.

Wenham dispenses with the use of the ordinary camera, and yet attains its purpose most completely with sundry advantages. He advises a room to be selected having a window or aperture with free access to sunlight. This is closed by a shutter having a hole about 3 inches in diameter; upon the outside of this aperture is arranged a solar reflector or plane mirror, in such a manner as to be capable of being worked round its centre at the necessary angle, on the outside, by passing the hand through another hole in the shutter to the margin of which a flexible sleeve is attached. The microscope body is arranged horizontally on a table or bench, so that its axis corresponds to the centre of the aperture. The stage with the object slide clamped on it in proper position, is placed near this aperture on the inside, the light around the stage being shut off by a piece of black cloth. On the bench a vertical stand, consisting of a board with a heavy base, is placed at any desirable distance from the eye-end of the microscope; this board is supplied with two "under-cut fillets" to hold the sensitised plate when ready. The mirror is first properly arranged so as to throw an equal illumination on the vertical frame-board, a card being previously placed in the exact plane to be occupied by the prepared plate. The image is now focussed on the card. Supposing the operation of exciting the plate to be done in the same room, sufficient light for the purpose is admitted through a small pane of yellow orange non-actinic glass let into the top part of the shutter. When ready the card is removed and placed against the open end of the microscope tube, so as to cut off all light through it, the plate is drained and placed on the vertical frame, the card quickly lifted and replaced against the end of the tube in periods varying, according to the time of exposure necessary, from part of a second to half a minute. The time required will vary according to the quality of the light, the sensibility to it of the collodion or other material used, and the facility with which the actinic rays pass through the object.

Mr. Wenham enumerates several advantages combined in this method. The length of base-board is limited only by the dimensions of the room. The ease with which any object can be included in a definite space. Facility in focussing--a means of so placing the card or sensitised plate at any angle to the axis of the microscope that the surface may be made parallel to objects lying a little out of one plane, and by having a series of paper stops at hand, parts situated in planes, slightly removed from each other, can be focussed and impressed alternately. Then while the first part is being impressed, the other part is stopped off, this is then stopped off, the other part focussed and its image allowed to fall in its turn on the

unaffected portion of the prepared plate. Again, the thicker and thinner parts of the same object may be exposed for different periods of time, by which a uniform intensity may be obtained in spite of the variable transparency of different parts.

For the low powers the plane mirror, but for the  $\frac{1}{2}$ -inch objective and higher powers some form of condenser is used, as a bull's-eye lens, about 3 inches diameter. But for the finer forms of objects, as diatoms, the bull's-eye lens is to be combined with a condenser of the form proposed by him in April, 1861, for his binocular microscope. This consists of a set of three plano-convex lenses varying in diameter from about  $1\frac{1}{2}$  inch to  $\frac{1}{2}$  an inch, placed near to each other with their flat surfaces towards the object. These combined possess a very large angle of aperture. The small lens being made separable from the others, a large field of illumination could be obtained for the lower powers.

**327. Brevet Lieutenant-Colonel Dr. Woodward's Method.**—This will be a suitable place to introduce the plan adopted by Lieutenant-Colonel Dr. Woodward, at the Army Medical Museum, U.S., and which we quote nearly verbatim from the British Journal of Photography for October 12th, 1866. "A camera is not used, a dark room being found most convenient. The operating room has two windows, through one of which just enough yellow light is admitted to permit the movements of the operator. The lower part of the other window is occupied by a shutter about fourteen inches high, on which the blackened sash shuts down light-tight. In this shutter is a round hole an inch and a-half in diameter, from the inner side of which a brass tube of the same diameter projects into the room. On the outer side of the hole is a rod about twelve inches long, on the extremity of which the microscope mirror is duly centered. Two steel rods attached by hooks to the mirror and passed through the shutter, permit its position to be adjusted by a person standing inside of the room, without opening the window. A Silbermann's heliostat standing on a shelf just outside of the window, throws the sunlight steadily upon the mirror. Within the room a frame of walnut, ten feet long, is placed on a firm table perpendicular to the window. The microscope stands on the end of this frame next the window; its mirror is removed, being replaced by that outside the shutter. The microscope is placed in a horizontal position, and the tube carrying the diaphragm or the achromatic condenser fits into the tube projecting inward from the shutter, by which the sun's light reflected from the mirror outside is admitted. A black velvet hood covers the parts about the stage and objective of the microscope, and thus prevents the leakage of light into the room.

"The plate-holder is moveable backward and forward on the walnut frame on which the microscope stands, its maximum distance from the stage of the microscope being nearly nine feet.

"To permit ready focussing at distances greater than the length of the arm, a wooden rod three fourths of an inch in diameter and capable of easy rotation runs the whole length of the right side of the frame. The milled head of the fine adjustment of the microscope is grooved, and a grooved wheel in the end of the rod permits the two to be connected with a band. The operator standing at any part of the frame can therefore manipulate the fine adjustment by simply turning the wooden rod in his fingers. The arrangements of light, position of object, coarse adjustment, &c., are made by the operator, who stands by the microscope, which has a suitable eye-piece adjusted, and observes the object in the usual way; afterwards removing the eye-piece and going to the plate-holder, the final focus is made by means of the wooden rod, the image being viewed with a focussing glass on a piece of *plate-glass* held in the same frame which is to receive the sensitive plate.

"The cell containing the ammonio-sulphate of copper hangs outside the shutter over the hole by which the light is admitted. It not only excludes the unnecessary illuminating rays, but prevents danger to the objective from the concentrated solar heat, and permits the eye of the operator to view the objects about to be copied without fatigue or injury. Latterly a plate of alum has also been used to exclude solar heat, especially during any temporary removal of the ammonio-sulphate cell. The chemical processes employed are well known to all photographers. With the above apparatus, it has been found that the best defined pictures are obtained when the distance employed with any objective does not exceed three or four feet.

"The achromatic concave used as a substitute for the eye-piece, is a combination of somewhat more than half an inch transverse diameter, and about  $28^\circ$  angle, constructed like the objective to focus the chemical rays. It increases the magnifying powers of the objective about seven times. It has been found to perform well with both the  $\frac{1}{8}$ th and  $\frac{1}{10}$ th.

"In photographing the soft tissues or other objects in which illumination with parallel rays produces interference lines, the ground glass is to be placed between the mirror and condenser. Of course there is considerable diminution of light, but this can be overcome for the higher powers by condensing the sun's light on the ground glass by a bull's-eye, or other similar contrivance. If the interference lines as seen by the eye do not disappear with one thickness of ground glass, two or more may be used."

Dr. Woodward, besides these explicit details, in the same article has laid down the following principles :—

“1. To use objectives so corrected as to bring the actinic rays to a focus.

2. To illuminate by direct sun light passed through a solution of ammonio-sulphate of copper, which excludes practically all but the actinic extremity of the spectrum.

3. Where it is desired to increase the power of any objective, to use a properly constructed achromatic concave instead of an eye-piece.

4. To focus on plate glass with a focussing glass instead of on ground glass.

5. With high powers to use a heliostat to preserve steady illumination.

6. Where an object exhibits interference phenomena when illuminated with parallel rays, as is the case with certain diatoms and many of the soft tissues, to produce a proper diffusion of the rays by interposition of one or more plates of ground glass in the illuminating pencil.”

Dr. Woodward sent me photographs of a part of a frustule of *Pleurosigma angulatum* taken by him. The original negatives were obtained in the one case by Messrs. Powell and Lealand's  $\frac{1}{50}$ th, and magnified to 2,344 diameters ; in the other case, by a  $\frac{1}{8}$ th, made by Mr. Wales, of Fort Lee, New Jersey, and used with his achromatic concave magnified to 2,540 diameters. Both of these negatives were afterwards employed to procure positives, and from these, by one enlargement, the enormous magnitude of 19,050 diameters. The former gave, if anything, rather the sharpest picture, especially in the centre, the latter the flattest field with most excellent definition. The slight advantage in sharpness, attributed to the  $\frac{1}{50}$ th, Dr. Woodward considers to be due to the chemical process employed. These negatives were taken on collodion prepared plates, and the exposure given was seven minutes. They certainly speak directly to the excellence of the plan adopted, and the skill and patience of the operators, Drs. Woodward and Curtis.\* When we consider the number of reflecting and absorbing surfaces and materials we may be prepared for his lengthened exposure. It remains then to be tested whether by adopting other plans we may not get rid of some of the expensive parts of the apparatus, namely, the heliostat, and Dr. Maddox is now

\* Dr. Woodward in a letter to Dr. Maddox, March 25th, says, “a still more perfect instrument is being constructed under the superintendence of Dr. Curtis,” and in a letter dated June 19th, testifies to its great superiority and

experimenting in this direction, by means of a solar microscope. He finds on an ordinary collodion sensitised plate, bath in good condition and iron developer, the exposure with a  $\frac{1}{8}$ th, and achromatic concave, a large plane silvered mirror, a  $3\frac{1}{2}$ -inch diameter and  $8\frac{1}{4}$ -inch focus condenser, and a single pair of plano-convex condensers with a large central stop, the time necessary for a negative of *Pleurosigma angulatum* magnified 2,500 diameters was under strong sun light in December 90 to 110 seconds, in May 70 seconds for *Pleurosigma formosum*. He attributes much of the lengthened exposure to this  $\frac{1}{8}$ th being made with 4 sets of lenses, the front a single lens. With an excellent  $\frac{1}{8}$ th with three sets of lenses and an achromatic concave, made for him by Mr. W. Wales, of Fort Lee, New Jersey, U. S., especially for photographic purposes, the time of exposure is rather less; and with a triple condenser 35 seconds in June, for *Pleurosigma angulatum* magnified 3,000 diameters using the ammonio-sulphate of copper cell. From a short experience with this instrument, both with and without the ammonio-sulphate of copper cell, he thinks a prism either after the plan used in his smaller camera arrangement or as adopted by M. Neyt and Count Castracane preferable to a mirror for illumination with the high powers. To adapt this objective to ordinary use, Mr. Wales supplies a separate back set of lenses to replace the photographic set, which answers well, the workmanship in the construction of the mount being most perfect.

There is every reason to suppose the very valuable invention of Mr. Wilde, in magneto-electricity might be most successfully employed for this purpose; perhaps the lamp invented by Mr. Larkin, for consuming powdered metallic magnesium mingled with sand and allowed to fall in a stream through a small lighted jet of hydrogen gas. Whichever plan may be selected, the chief object is to have the intense light necessary, emanating from a small surface, so that it can be more successfully brought to a focus by a condensing lens or silvered reflector, singly or united. At the end of this part attention is directed to the use of magnesium wire, &c. The Rev. St. Vincent

efficiency over the arrangement described. Since the above was written, Dr. Maddox has received from Lieutenant-Colonel Dr. Woodward for publication, an important illustrated paper, in which he gives the results of some experiments made to test the value of the actinic rays emanating from a flint prism at the violet end of the spectrum, as compared with the illumination from a silvered mirror, the rays being transmitted through a cell containing a solution of the ammonio sulphate of copper. Considerable advantage is shown in favour of the latter plan. The test, however, does not decide the question as to the advantages of a condensing prism, or an ordinary silvered mirror, but Dr. Maddox has always considered that the former affords the best results.—See Appendix to this work.







Beechy, in his paper on Microscopic Photography, recommends very strongly the oxyhydrogen light, and indicates a very simple method by which an ordinary good magic lantern can at a small expense be converted into use as a microscope camera for powers from 1 inch to the  $\frac{1}{4}$  inch. Dr. Woodward's arrangement will be understood if pl. LII be referred to.

**328. Camera applied to the ordinary Microscope.**—We may now consider the plans for employing the microscope and camera united. Mr. Shadbolt recommends the draw tube, if any, to be removed, and its place supplied with a lining of black velvet. The microscope is fixed horizontally on a board or table, and the body made to correspond to the centre of the aperture left on the removal of the lenses from the brass setting of an ordinary camera. The intervening space being closed in such a way as to exclude all entrance of extraneous light. The draw chamber of the camera is employed to vary the distance of the image from its object, but is usually deficient in length, hence some plan for elongating this chamber is needed. Many complain that when using the microscope in this way, some uncertainty in the centering, and liability to derangement when exchanging the focussing screen for the prepared plate are experienced. Gerlach adopts a very different arrangement. The camera is adapted to the top of the tube of the microscope which is placed in an upright position, pl. LIII, fig. 339.

**329. Dr. Maddox's Camera.**—The instrument proposed by Dr. Maddox, and used by him consists of a microscope having a compass-joint at the lower end of the stem furnished with coarse screws, &c. The stage slides along the stem, and can be clamped to it by a binding screw against a guide that runs along its length. This stage is provided with small rectangular movements attached to the part holding the object slide, and to its opposite side is fixed a stout tube to hold an achromatic or some form of condenser. The main part of the stem is hollow, and receives a strong tube furnished nearly in its entire length with a slot that works on an internal guide fixed inside the stem. This tube carries at its near end an arm, at right angles to which a tube about five inches long is screwed on the near side, and on the opposite side an adapter is fitted to receive the screw-end of the objective. An approximate focus is effected by sliding the stage along the stem, and the fine motion by a graduated milled-headed screw-pin. This pin passes through the tube to which the arm is fastened, and engages in a thread cut in the solid end of the stem. A spiral wire coiled in the inner tube reacts on the arm when the milled-headed screw is withdrawn.

The whole of these arrangements are fixed firmly by the screw and nut at the jointed ends of the stem, to a rectangular cross piece of 3-16ths iron bar about two inches wide, the screw passing through a hole near its centre. This cross piece is turned down at right angles on each side so as to bring the centre of the short microscope tube in the centre of the camera, then again turned at right angles and firmly screwed to a stout base-board of deal  $1\frac{1}{4}$  inches thick, 12 inches wide, and 48 inches long, and clamped at each end to prevent warping. This is supported over a wide moveable triangle, having stout double-hinged triangle legs of a height convenient for the operator (3 to 4 feet), pl. LIII, fig. 304 A. About 12 inches from the end of the base-board where the microscope is fixed, is hinged a stout square frame with a sliding door having a central aperture to allow the end of the microscope tube to work through. The inside of the aperture is lined with leather, and a thick velvet collar is made to slide along the tube and abut against the aperture in the door, so that when in use the entrance of any extraneous light is effectually prevented. The frame with door is turned on its hinges, until it stands exactly at right angles with the axis of the microscope, and is kept firmly fixed in this position by two stout brass struts with clamping screws, that rise from the base-board on each side of the frame at an angle of  $60^\circ$ . At the opposite end of the stout plank is placed an ordinary camera with a moveable door-front having a *large* central aperture. One end of an expanding bellows body is fastened to it, the other end being attached to the door that slides into the vertical frame. This bellows part is made of two thicknesses of black twilled calico, having pasted between them a corresponding sized sheet of stout brown paper, and folded into one-inch plaits when damp, then turned over square to the size corresponding to the sliding doors, the corners bent down like the bellows of a common accordion, and the overlapping edges which are turned so as to face the base-board are double sewn together throughout their length; or for this may be substituted a body of black calico, of treble thickness, attached at each end to the doors, and kept apart laterally by elastic bands sewn along its four edges, lengthwise. The camera is made to slide along the supporting board between wooden guides screwed to its upper surface near the sides, extending from the near end to the vertical frame. These have small holes at corresponding equal distances of half an inch, and projecting from each side of the body of the camera is a pierced horizontal ledge of brass plate, about 5-8ths wide, that travels over the upper surface of the guides on the to and fro movement of the camera, a moveable pin on each side fixing it in the place desired.

These apertures are numbered according to the inches 1, 2, 3, &c., from the frame, and thus are of service to note the distance at which the sensitised plate is placed from it or from the stage. Memoranda being kept, the same ranges can be easily repeated. The draw chamber of the camera has its own focussing screw which is of use occasionally, but it is not necessary.

Two diaphragms of blackened stout card are placed within the chamber of this elongated camera, one near to the vertical frame or at the junction of the bellows part with it in front, and the other is placed in a grooved frame, that slides in a wide cut made in the inner surface of the underside of the draw part of the camera. This frame holder takes diaphragms with various sized apertures, according to the dimensions of the image of the object or the glass plates employed. Sliding this forward or backward in the camera alters the relative size of the field according as the camera is used expanded or closed. The camera is either dead-blackened, or lined with black cotton velvet, and the tube of the microscope inside is well covered with optician's charcoal black, or lined with black velvet, which is better.

The mirror or prism is set on a separate arm fixed to the base board in a line with the stem of the microscope, so that the axis shall correspond with the axis of the objective. The apparatus can be put together very quickly, or kept ready for use, and is of a size that permits of its being moved about easily, without being too cumbersome for one person; and it possesses considerable firmness.

The microscope portion can be supplied by any form of microscope that will take the horizontal position, and permit the eye-piece end of the body to work through the central aperture in the front of the bellows-chamber, provided means are taken to effect rigidity, and completely shut out the outside light around the aperture when working the rack for the coarse adjustment. But preference has been given by Dr. Maddox to a tube shorter than the usual body of the ordinary microscope, which sometimes narrows the field too much when the camera is nearly closed on the vertical frame. The tube consists of two parts, one an inch in diameter fixed to the arm, the other  $1\frac{1}{2}$  inches in diameter, that slides through the aperture in the door. On the open end of the latter fits a dead blackened brass cap, from the inside, with a slight internal projecting ledge, which acts as a diaphragm with a large opening.

The description will be more easily understood by a reference to pl. LIII, which represents the instrument partly in section. The camera, when drawn out to its full range, exhibits this objection: the operator is obliged to withdraw the head from the focussing screen

at the time of making any alteration in the fine motion. A lever arrangement has been used to obviate this, but if employed with the high powers it is extremely difficult to prevent a slight slip of the screw. Mr. Legg employed a lever crank and arm over the top of the camera, working on the milled head of the coarse rack and pinion motion. Professor Rood, of Troy, N.Y., also made use of a rod and lever beneath the camera, acting on the rack work, and a hinged mirror placed this side of the ground glass to receive the image transmitted to it while arranging the object on the stage plate, and attending to the illumination.

Dr. Maddox, who has much improved the before-mentioned apparatus, after trying several methods for supporting the rod, gave the preference to that described under his method of working without a camera in a darkened room. The rod being placed beneath the base-board, in which position it is less liable to accidental disarrangement, but in this case a stronger microscope will be required. Messrs. Powell and Lealand have lately made for me, according to some suggestions of Dr. Maddox, a stand which is steadier and possesses some advantages over that just described.

The chief requirements in any form of camera, independent of the objective or mode of illumination, are general facility of management, compactness within a moderate range of extension, correct centering, *freedom from vibration*, and the total exclusion of all light except that which enters by the object-glass.

### 330. Dr. Maddox's Arrangement for Working without a Camera.

—In order to take photographs without a camera, a room has been fitted up by Dr. Maddox as a dark chamber, the top sash of the window being darkened, and the place of the lower sash when thrown up supplied by a shutter with a large central opening; an oblong aperture exists at the right side of the shutter, protected by a frame glazed with yellow glass, which slides up and down, and is kept in position by a spring. The aspect happens to be direct S.W., and, unfortunately, very much exposed to the strong south-westerly winds; therefore to try and avoid the tremor occasioned by such a large surface as the shutter affords, no part of the microscope *is fixed to it*, but rests on a long stout base-board, supported on four double triangle legs. The shutter end is clamped by two screws, an upright piece at right angles, pierced to permit the attachment of a  $3\frac{1}{2}$ -inch solar condenser with its small condensing lens, the mirror of which is passed through the aperture in the shutter. This is worked by a double milled head from the inside, the ammonio-sulphate of copper cell being placed between the mirror and the condensing lens. The base-board with right

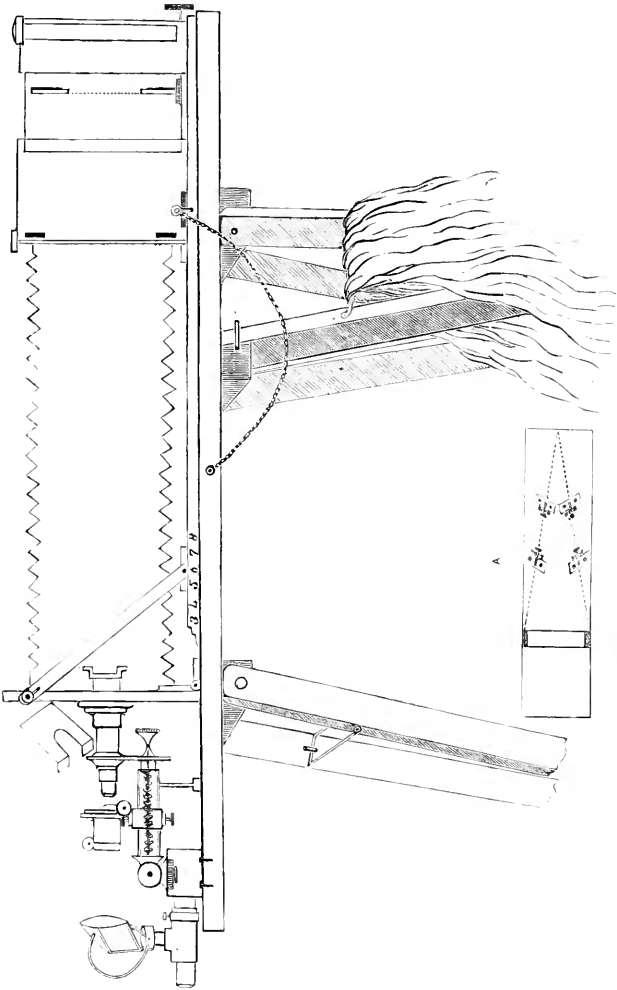


Fig. 40.

A. A perspective view of the camera as arranged by Mr. L. L. is described in p. 53.

A. A perspective view of the camera as arranged by Mr. L. L. is described in p. 53.

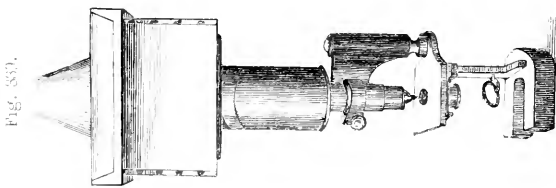


Fig. 537.

Mode of adapting the camera to the microscope adopted by Gerlach. P. 211.



angled head-piece is brought *almost to touch the shutter*, and the light around the upright piece excluded by a thick curtain. The microscope, which is *a heavy one*, is placed horizontally, and depending from the screw. Fastening the arm of the instrument to the rack, is a stiff piece of flat brass, pierced at its lower part to support the end of a rod suspended beneath the base-board, and provided at the end with a grooved pulley of the same diameter as the milled head of the fine adjustment, which is also grooved, a small endless band connecting them. The depending piece passes through a slot cut in the base-board, equidistant from the sides, and permits the rack of the coarse motion being worked, or the movement of the microscope backwards or forwards, the rod following it. This was the plan recommended in the last edition. The rod is placed beneath the board to be out of the way, and not to interfere with the traversing of the frame which carries the screen or sensitive plate. This frame is made with a heavy base the width of the board, and has side clamping screws. By means of a central pin, between the two parts which form the heavy base, it is capable of slight rotation on its vertical centre, to compensate for any want of parallelism in the parts right and left of the object, or for stereoscopic negatives. The square frame is hinged to the top of this base, to allow of slight motion forwards or backwards, being supported at the sides by two brass struts which have a clamping pin on each side. To arrange for glasses of various sizes, two bars undercut slide up and down the uprights of the frame and can be fixed at any distance apart by clamping nuts. The motion of the frame will often help to secure a perfect parallelism with the object on the slide. The screen may be either plane finely ruled plate glass, a collodion prepared washed plate over which a little albumen or tannin has been flowed, or the plate employed occasionally by Dr. Maddox;\* or the plate may be prepared as has been recommended for ordinary camera purposes by Mr. M. Carey Lea, of Philadelphia (whose contributions to the *British Journal of Photography* are marked with much originality and utility). Thin well-boiled starch is filtered through muslin, then poured to the depth of the tenth of an inch on to a clean polished plate of glass, set level, and allowed to dry spontaneously, but quickly. It must not be put in a drawer, for fear of it drying too slowly and the surface being irregular. Or, as in Mr. Wenham's method, p. 236, the image can be examined on a card, held as the glass screen or sensitised plate, by two springs from the transverse sliding bars.

\* Some closely filtered stale milk, either with or without a little weak solution of gelatine, poured on a plate of glass set parallel, and dried quickly.

Dr. Maddox finds the general appearance of the image and the condition of the field to be best seen on the card; therefore he uses this placed before the screen and resting against the frame, to procure the primary focussing, the final adjustment being made by the rod and fine motion, when examining the image by the focussing glass, on the slightly opaque screen, or on a thick card substituted for it, using a hand magnifier to examine the image, which he prefers.

In front of the exposed plate is arranged a diaphragm to exclude extraneous light, while the parts about the stage of the microscope *are well protected* from the light diffused through the slide from the sub-stage condenser.

Although this plan is very convenient, and allows everything to be ready at hand, it may be as well to point out some of its disadvantages. It is difficult to see the state of the sky; hence, after placing the sensitised plate in the frame, a cloud approaching unnoticed may at once obscure the sun and cause the loss of the plate. In the wet collodion process, dust is liable to settle on the surface. Again, for opaque objects which require a side illumination, as in the combined images for the stereoscope, the necessary deviation must be procured by prisms. Even if the Lieberkuhn with a portion of its surface stopped out, and the dark wells or stops, spot lens, or M. Nacet's cone be used, there will be considerable danger from leakage of light and a fogged plate. Moreover, the eyes become fatigued if kept long under yellow light. Some persons even complain of giddiness.

The plan for using some form of draw camera is to a great extent free from these defects, and the method proposed by Dr. Moitessier in his work, to which allusion was made in the early part of this chapter, appears so useful, that I shall briefly notice the chief points. The microscope arranged horizontally, with a grooved bar projecting beyond the base-board to carry the mirror, sulphate of copper cell, ground glass, and diaphragm, is centrally attached to an expanding camera. The dark box or part where the focussing screen is placed, has one of the sides to open with hinges as a door, and the operator seated by the side of the instrument, with or without a cloth drawn over the head to exclude the surrounding light, examines the image from the side opening, either with or without a magnifying glass, the right hand being occupied in the necessary arrangement of the object and the illumination; the plate being ready in the dark slide, and the side door closed light-tight, it is inserted and exposed without loss of time.

Dr. Moitessier has likewise recommended a slide with adjusting motions, so as to expose different parts of the sensitised plate one



after the other, to be placed on the end of the tube of the microscope arranged vertically, and thus secure small but very perfect representations for future enlargements, or for being viewed in the stereoscope. He also speaks highly of the objectives *à l'immersion*; a drop of distilled water being placed on the cover of the slide and the front lens focussed into and through the fluid, by which means the refraction occasioned by the thin cover is avoided. The surface of the lens is not to be wiped, but the water blown away. By continental microscopists these lenses, especially those made by M. Hartnach, have been very highly spoken of. Dr. Moitessier also employs an ingenious method for rendering opaque objects with the horizontal microscope and low powers. The object is placed on the stage of a small vertical microscope, and the light thrown on the object by a small plane mirror from above, which receives the solar rays, after having been converged from a larger mirror, by an achromatic lens; this and the small flat mirror are supported by, and slide on, an upright stem, to meet the necessary adjustments. The objective is attached to the end of the microscope tube at right angles, a prism with total internal reflection being fixed at the junction.

The focus is obtained by the rackwork acting on the small stage. For very low powers or securing the enlargement of only a few diameters, as in injected specimens and entire insects, a small portrait combination is attached to the microscope tube, and the prism placed in front of it at right angles.

**331. Arrangement of Drs. Abercrombie and Wilson.** — Drs. Abercrombie and Wilson, of Cheltenham, have met with great success with artificial illumination. These gentlemen use a blackened base-board 8 feet in length; the focussing box of an ordinary camera with its focussing screen, the microscope and illuminating apparatus being all kept in a straight line by side strips of wood. The microscope is moveable on a sliding board and can be clamped at any distance, or the camera box and microscope made to approach or recede from each other singly or together. A couple of strips of blackened wood are attached to the eye-piece end of the tube of the microscope, and brought slightly diverging to the top of the camera. The whole of this part being covered with black velvet, pile inwards, and well secured from outside light at all parts, especially round the tube of the instrument. The base-board can be set on any steady table or support. The focussing screen is of glass covered with collodion, sensitised and covered with a solution of tannin. The draw tube of the microscope, if any, is removed and the tube lined with black velvet. The correction for the want of concordance of the actinic and visual focus is effected by

what is called "turning out." The coarse or rack adjustment is left for focussing. By means of a lever arm at one end, clamping the milled head, and at the other connected to a long rod resting at the side of the apparatus, a very delicate movement is obtained. The fine adjustment is left to regulate the compensation required between the chemical and visual foci, and to mark this more easily, a "dial plate of card" is attached to the body of the microscope, whilst a wire which at one end is bent to clip the milled head of the fine focussing screw, is at the other used as the index point for the divisions of the card.

The condenser recommended is a 3-inch focus bull's-eye lens, with its convex side to the source of light, and in conjunction with this the objective next below the one in use. Oil lamps, oxy-calcium and magnesium lights have been used, but the last is preferred, and the wire to be burnt in preference by successive flashes. To secure the point of light being in a proper position "a small telescope upright, of brass, regulated by a screw, is fixed to a block adapted to slide in the support common to the microscope and light; at the apex of the brass upright is fixed a small tin gutter or pipe of sufficient capacity to admit the wire easily and diverted down at an angle of  $45^{\circ}$ ."

A moveable stop with a pin-hole aperture is recommended to be used in the preliminary arrangement to secure the exact position; about  $\frac{1}{4}$  of an inch of the wire is exactly opposite the pin hole.

The camera is set to certain lengths so as to give images of the objects of a definite size. The "turning out" consists in actually testing each objective for the number of turns or parts of a turn of the fine focussing screw by means of the dial card, to make the correction for the actinic focus. In the high powers this may be almost disregarded, and the same result may be obtained by withdrawing the focussing screen to the point where by trial the true actinic focus has been found. In the Popular Science Review, No. 22, 1867, will be found an illustrated memoir by Dr. Wilson, in which full particulars have been given, and from which the foregoing remarks have been taken.

The time of exposure for wet collodion plates varies, increasing according to the colour of the object, and its enlargement;—50 diameters and a tolerably light object may need ten minutes with the oil-lamp. By placing a small vessel of warm water in the camera, to keep the collodion plate moist by its vapour, Drs. Abercrombie and Wilson have exposed plates forty minutes with success. Some of the prints from these gentlemen's negatives are remarkably good; they possess a peculiar delicacy in the half-tones and shadows,

with much roundness of the objects, but the definition, as might be expected, does not quite equal, in some of the finest markings, prints obtained from sun negatives. However, all of the general characteristic appearances of the objects are exceedingly perfect. Great simplicity in the apparatus, and the immense advantage of useful illumination in all weathers, are most favourable recommendations.

**332. Of the Illumination: Sunlight: Monochromatic Light: Polarising Apparatus.**—Both sunlight and artificial light have been used. Dr. Maddox, with the majority of observers, gives the preference to sunlight in all cases, and nearly always uses some form of condenser. He usually dispenses with the mirror, and substitutes one of Abraham's achromatic condensing prisms, placed at such a distance from the object (if used alone) that its rays should cross just before reaching it. Otherwise the intense heating power at the vertex of the cone of rays would cause considerable danger to the object, and might even uncement the lenses of the objective of the higher powers, especially when the object is only enclosed between two pieces of the thinnest covering glass, and the focus very close. The prism he seldom employs alone, but places in the tube at the back of the stage a condenser. A small Coddington lens about  $15^\circ$  angular aperture, served him in the earlier part of his experiments. This was made to slide nearer or farther from the object. Latterly he has used Sollitt's achromatic condenser, as furnishing a larger field and more free from spherical aberration. This condenser, as described by the originator, consists of two achromatic lenses with their plane surfaces turned towards the object, and of 2 and 4 inches focus respectively, placed at the distance of one and three quarters of an inch apart with a diaphragm between them. The four-inch focus lens has a diameter of  $1\frac{1}{4}$ -inch, the two-inch focus lens a diameter of  $\frac{3}{4}$  of an inch. Here then we have a body of light, and a field beautifully illuminated when used either with the plane mirror or the prism. A series of diaphragms slip into the cap covering the small lens, which is turned towards the object. Sometimes Dr. Maddox employs an achromatic doublet of about  $22^\circ$  aperture, or an achromatic condenser of larger angular aperture. Although theoretically the angular aperture of the higher objectives is narrowed by these moderate apertures, practically the intensity of the illumination appears to compensate in a remarkable manner, as is shown by the perfect delineation of some of the figures in the frontispiece. The common plan is to use as a condenser the objective next below the one used to render the photographic image; but if any form of solar condenser be employed by which the rays

become more concentrated, the greatest care will be required to avoid injury to the lenses by the intense heat.

Dr. Maddox has lately used two large plano-convex lenses superposed with a large central stop—Dr. Woodward's method as described in one of his communications; also the condenser of two or three plano-convex lenses as recommended by Mr. Wenham, but with moveable stops or diaphragms; the latter are placed nearer to or farther from the largest lens, the distance being regulated by trial.

Prof. Rood, of New York, for his higher powers employed a Wollaston doublet, having an angular aperture of  $44^\circ$  as a condenser. He used one of Liebig's silvered mirrors in place of the ordinary amalgam mirror.

M. Neyt replaces the common solar reflectors by a large prism with parallax motions; to condense the rays an achromatic condensing lens of  $2\frac{3}{4}$  inches diameter is used, and to concentrate them still more, 3 other converging lenses are placed in its focus in such a manner that they can be used together or separated to meet the power of the objective. He likewise has the objective corrected to make the chemical and visual foci agree. In order to render infusoria stationary while they are photographed, he uses a voltaic stage, so that he can make contact with the poles of a Daniel's battery or induction coil at the proper moment. The shock suddenly kills the little beings and enables him to secure an image, when otherwise, from their rapid movements, it would be a mere accident if the animalcule remained in the field of view, or in the desired attitude.

The Rev. Mr. Reade has proposed a very ingenious method of using his hemispherical condenser with a solar condenser. The rays furnishing light and those giving heat having different degrees of refrangibility, we have here the cone of light-giving rays formed within the cone of the heat-giving rays, the principal focus of the latter being at a greater distance from the lens than the former. When these rays are permitted to cross the axis, their respective situations are reversed. On arranging the hemispherical lens, so that it shall be separated from the principal focus of heat by the sum of its own focal length, the principal focus for light will be found at a greater distance than its own focal length; hence the heat-giving rays will be rendered parallel, and the light-giving rays will be made to converge to a second focus furnishing light of much intensity separated from the heating rays. Means for using an achromatic object-glass for the solar microscope without endangering its injury are thus supplied.

Professor Gerlach uses a plano-convex lens with a concave

mirror. These are placed at such distances apart that the two foci meet when the convex surface of the plano-convex lens is turned towards the mirror, pl. LIV, fig. 337.

Dr. Woodward's plan has been already adverted to in p. 237.

Dr. Moitessier gives the following method:—the parallel rays from the solar mirror are received on a bi-convex lens and conveyed to the other extremity of the tube holding the lens, in which, slides by rack and pinion a smaller plano-convex lens. According to the position of the latter, the emergent rays are rendered either parallel, or diverging if placed beyond the principal focus of the large lens. If placed within the luminous cone before being brought to a focus the rays are rendered more convergent, and this forms the general arrangement for high powers. If the small image of the sun thus formed be made to coincide with the surface of the object to be photographed, the phenomena of interference from diffraction are avoided, but this involves an alteration in the respective distances apart of the lenses for different objectives, or the same objective altered in its focus to correspond with any deviation in the distance of the screen. He likewise substitutes for the small condensing lens, a diverging one placed within the focus of the large lens to procure a cone of concentrated parallel rays. These can be again rendered convergent by a small lens. He also receives upon finely ground glass the converging rays from a large condenser with a longer focus at some point before coming to a focus. This circle of light then becomes a radiant for the small condensing lens. Thus there is much less diffraction, and although the time of exposure is considerably increased, the plan meets the general requirements. The drawings represented in fig. 338, pl. LIV, will illustrate these different methods.

The mode adopted by the Abbé Count Castracane is to allow the solar rays to be refracted by a large prism, with a dispersive power capable of giving a wide spectrum before falling on the condensing lens; a diaphragm being interposed to allow passage only to the rays from the blue end of the spectrum. In this way homogeneous light, in which the actinic power is chiefly situated is obtained, the defects arising from chromatic aberration are avoided, and a more perfect definition results.

Dr. Maddox found when using the blue cone of rays formed by Abraham's achromatic prism, a great tendency in the object, if very thin and transparent, to be confounded with the field, and the negative to be useless for obtaining positives for the lantern. Care is required not to employ any form of sub-stage condenser of a *larger angular aperture* than the objective in use. In practice a saving of

time is effected if the objects be first selected for a suitable objective and the mode of illumination arranged accordingly.

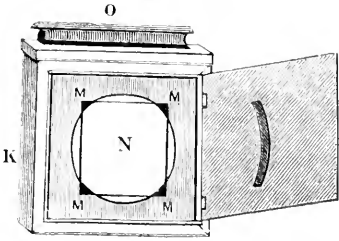
For such objects as are of a more or less non-actinic colour, as some entire insects, or their various parts, Dr. M. also tried a plan by giving to the supporting slide a coloured transparent varnish of the same tint, or by placing beneath the slide holder a parallel plate of tinted glass chosen to suit as nearly as possible the necessity of the case. But the best results were obtained by using a slow collodion, a more acid bath, and giving a longer exposure, which was done without fogging. Some of these results were exhibited on the screen before the London Photographic Society in Dec. 1864, and the Microscopical Society in March, 1865. It should be borne in mind that when any coloured medium is placed between the mirror and objective, it has the most effect when placed at the part where the light is least concentrated, and also that there is no conversion of white light, but simply a transmission of the blue and closely allied actinic rays when the ammonio-sulphate of copper cell or blue glass is used; hence the time of exposure must be augmented.

It is a desideratum to obtain the monochromatic and actinic rays without having lost so much of their power by transmission and absorption; and it is just possible in the case of objects which can be mounted in fluid, that such a medium may be found as may enable us to employ the ordinary methods of illumination. I believe Dr. Maddox is experimenting in this direction. It has also been proposed to focus through a screen of polished parallel blue glass, and to remove this when the sensitised plate is being impressed.

Various media require different exposures under similar conditions of illumination; without a heliostat, rapidity in impression is necessary to the most perfect definition. The refracting power of the medium should correspond closely to the refracting power of the object.

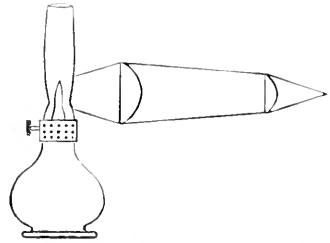
The time of exposure varies from so many causes that it proves one of the chief difficulties in photomicrography; the distance of the object from the screen, its colour, the medium in which it may be mounted, the media through which the sun's rays are transmitted, the nature of the first incident or reflecting surface—the actinic power of the sunlight, which varies considerably at different hours in the day, the condition of the atmosphere, and the number of lenses of which the objective is composed. This last operates greatly, those in the high powers consisting of only three sets, and the first a single front, as Mr. Wenham's,—being the most rapid. Experience and trial are the only guides to success.

Fig. 51.



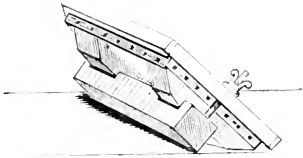
Photographic plate holder. p. 107.

Fig. 52.



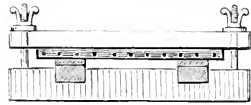
Condensing lens system used for condensing the light of a lamp, as an alternative for the plate holder. p. 108.

Fig. 53.



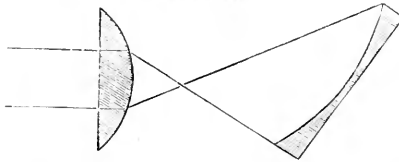
Pressure frame used in photographic printing.

Fig. 54.



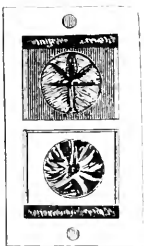
Another view of pressure frame. p. 108.

Fig. 55.



Another view of a curved parallel rays is recommended by the author. p. 109.

Fig. 56.



Pressure frame used.

Fig. 57.

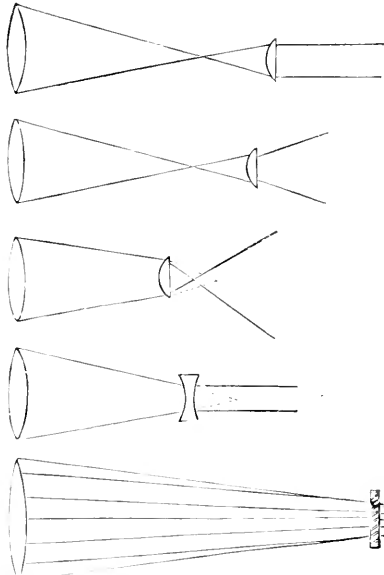


Fig. 58.



Vertical views of plate holders.

To illustrate the observations of the author on the effect of the condenser lens. p. 109.





In the ordinary Wollaston doublet the chromatic aberration is not corrected, but this does not cause any serious difficulty, as by varying its distance, the blue or chemical end of the converging cone of rays can be used to furnish a field of bluish light. Some considerable care is needed in the adjustment of the condenser, whichever kind be employed, so as to equalise the illumination and avoid sun spots when the mirror is used. Mr. Traer got rid of these by making the distance between the object and concave mirror rather more than its focus. The chief aim is to have the full amount of light that will furnish a distinct image on the ground glass. Some make their focal arrangements in the objective, illuminating the object with daylight or a less intense illumination than is to be used in taking the photograph. Dr. Maddox found that in doing this he seldom secured the best focus, therefore he prefers to focus in sunlight condensed upon the object, using an examining eye-piece.

In using the *polarising apparatus* for the production of photographic images in some objects which from their great transparency and delicacy are not well rendered in the ordinary way, or some detail lost by using common light, a little care is required. The polarising prism is as usual placed beneath the object, the analyser directly over or behind the objective, and the best appearance sought by the rotation of the lower prism. Mr. Thos. Davis, who has furnished in the *Microscopical Journal* for the years 1863 and 1864, many details connected with the application of photography to delineating delicate crystals, states that he finds when the object appears best illuminated by the ray which has been reflected from the mirror and transmitted through the polarising prism, the image in the camera was often only partially distinct, and needed a readjustment of the mirror to procure an image that would develop uniformly. He employed a No. 1 eye-piece, and magnified some of the crystals, as tartar emetic to 50 diameters, tartrate of soda, sulphate of copper and magnesia, and santonine to 40 diameters. Excellent woodcuts from these photographs were given in the *Journal* to illustrate his observations. To these I must refer the reader.

**333. Artificial Light.**—Mr. Shadbolt many years ago obtained some beautiful photographs by lamp light. A small camphine or paraffin lamp was placed so that the flame was in the axis of the microscope. A plano-convex lens of about  $1\frac{1}{2}$  inch diameter with its flat side to the lamp, and a second smaller one of about 1 inch in diameter and 3 inches focus, were arranged so as to concentrate the rays of light without forming an image of the flame, pl. LIV, fig. 336. The first is placed at such a distance from the lamp as

to make the rays converge slightly, and the other at a point where it will include all these rays and (in using high powers) the achromatic condenser, so that the lens may fall well within the cone of rays. In employing low powers the object is made to come within the cone of converging rays. The distance of the lamp from the nearest lens to it, is best determined by the quality of the illuminated field, which should be equally bright, nor should the light enter the objective at a greater angle than its own angular aperture. To examine the image thrown on the ground glass of the camera, Mr. Shadbolt used a Ramsden's positive eye-piece.

Mr. Legg, in 1859, made use of artificial light from a camphine lamp, concentrating the diverging rays by a two-inch bull's-eye lens placed near to the source of light, and a second bull's-eye lens about three inches in diameter at a distance of an inch from the first, by which, with the 2-3rds and 4-10ths object-glasses, he could obtain images at 3 feet, in periods varying from 3 to 10 minutes.

Mr. Parry, in making use of artificial light, placed a plano-convex of  $1\frac{1}{2}$  inch focus with its plane side towards the object about one inch from it, and four or five inches from an argand gas burner. (The light from an argand paraffin lamp is preferable to gas.) To increase the flatness of the field, he fixes behind the posterior lens of the 1-inch combination, an achromatic stereoscope camera lens with its flat surface towards the objective. The advantage of the brilliant light produced by the combustion of magnesium wire is referred to in p. 275.

**334. Of Focussing.**—Much care is required in focussing. A plan adopted by some is to use a simple lens set as a watchmaker's loupe in a card or wooden tube of such a length, that when placed at the near surface of the ground glass screen, the focus of the lens exactly corresponds to the opposite or ground side. Others employ an ordinary photographic focussing eye-piece. The best is the positive eye-piece, for should the others not be truly set, there is danger of the focus catching the image either before or behind the screen, unless some form of compound microscope be employed, with its focus set to the exact thickness of the screen.

**335. Of the Object-glasses.**—Each objective, as furnished by our best opticians, is generally sent out not as a *photographic* object-glass, but as a microscopic objective, and so skilfully have errors which arise from the thickness of the thin glass cover and non-achromaticity of the eye-piece been compensated for, that the illuminated field is without sensible colour, and the edges of objects destitute of chromatic fringes. To accomplish this, the objective is left what is termed "over corrected."

When the photographer employs these objectives, more especially the low and middle powers, he generally finds that either his prepared sensitised plate must be moved further away from the plane at which the best visual focus was found, or else he must withdraw his objective a slight distance from the object, and bring the chemical focus to its compensating point for the amount of "over correction" that has been given to it by the maker. This is not a fixed sum, and may vary in different object-glasses furnished by the same optician, when of equal magnifying power, or even ground on the same tools. In the construction of some of the lower powers a plan has been adopted which, at the same time that it does not detract from their optical perfection, places the chemical variance at its lowest mean. In the higher powers, as from  $\frac{1}{5}$ th upwards, the difference between the visual and chemical foci is so small that it is seldom regarded, except in the most delicate work; but here the disturbance occasioned by the cover of thin glass placed over the object, requires the adjustment between the two posterior combined set of lenses, and the anterior pair, triple or single lens, to be made with the greatest nicety, as has been strongly advocated by Dr. Wilson. It is not possible to determine beforehand the amount of alteration in focus needed, and a series of trials will be necessary to establish what adjustment is requisite. The best plan is to select an object that has a slight thickness, with parts at a distance from one another, lying in three or four different planes. Set the objective to the best focus in the microscope, then place it in the camera; focus sharply for the part of the object nearest, and in the negative which is taken, observe if this part corresponds in definition, or if not, which plane of the object appears the sharpest. Let us suppose the furthest plane; then observe, by re-focussing, how many divisions of the milled-headed screw have been turned through to bring this part into as perfect a focus as was originally the nearest plane. This will give the variation for that objective under similar circumstances, and should be noted. If employed with the shallow eye-piece, to increase the magnifying power, with the loss of some definition, a different adjustment may be required. Mr. Shadbolt undertook a series of experiments for his objectives, of Messrs. Smith, Beck, and Beck's make, when he employed artificial light, and which he gives as follows:—

The  $1\frac{1}{2}$  inch object-glass to be withdrawn  $\frac{1}{50}$ th of an in.

The  $\frac{2}{3}$ rd " "  $\frac{1}{200}$  " "

The  $\frac{1}{4}$ th " "  $\frac{1}{1000}$  " "

These can only be regarded as guiding marks for others. To obviate this great inconvenience, Mr. Wenham, to whom we owe much for the perfection of the binocular microscope, with his usual

ingenuity, recommended a biconvex lens of low power to be carefully turned down to the proper size, and centered in a setting that can be screwed into the place where the posterior diaphragm or stop is usually placed; thus to lessen the over correction and to bring the chemical back to the visual focus. He gives the following focal lengths of these correcting lenses for Messrs. Smith, Beck and Beck's  $1\frac{1}{2}$  inch, a lens of 8 inches focus; for the  $\frac{2}{3}$ rds one of 5 inches focus, which is also applicable to the  $\frac{4}{10}$ ths.

Mr. Hislop advises that a dozen of these, of different foci, should be at hand, and the one that is found to answer best in practice selected. Dr. Maddox has one of Messrs. Smith, Beck and Beck's  $\frac{2}{3}$ rds, beautifully corrected by them in this manner, and it gives surprising sharpness.

Mr. Shadbolt prefers to find the necessary alteration for the foci of different objectives. It seems almost a matter of regret that opticians have not offered a special correcting eye-piece to be employed with the one-inch or two-thirds objective, so that we might obtain, at moderate distances, the advantage of the increase in magnifying power, and at the same time preserve the unison of the actinic and visual foci, and give a more perfect flatness of field; but in this case the eye-piece would require to be most correctly centered, both with regard to itself and in relation to the axis of the object-glass. Object-glasses with large angular apertures, unless possessing great flatness of field, with perfect correction for spherical and chromatic aberration cannot be expected to supply the most useful photographic objectives.

In giving the amplification of an object, the simplest plan, perhaps, is to divide the screen from the centre into inches and tenths, to measure the size of the image and compare it with the size of the object as given in the microscope with the micrometer, or to substitute the micrometer for the slide, taking care to let their surfaces coincide, and not to alter the correcting adjustment, as with the high powers and single fronts the alteration in size is very rapid.

**336. Stereoscopic Photographs.**—Seeing the advantage derived from the application of the stereoscope in viewing the dissimilar images of large objects taken at varying angles, it was natural to suppose that an effort would be made to produce stereoscopic images of minute objects. Professor Wheatstone suggests in the Transactions of the London Microscopical Society, for April, 1853, a plan of procuring these at the necessary angles. He proposes that the tube of the microscope should have an independent movement of about  $15^\circ$ , “round an axis, the imaginary prolongation of which

should pass through the object, it being indifferent in what direction this motion is made in respect to the stand." He proposes also a simpler method, which is, to make the object itself partly revolve round an imaginary axis within itself, from  $7^{\circ}$  to  $15^{\circ}$ , care being taken to render the illuminations equal, and avoid interfering shadows, so as not to produce pseudoscopic effects.

Mr. Wenham showed that images of objects could be produced with such a difference in the relative position of their parts when viewed, by stopping off the alternate halves of the object-glass, or the emerging pencils from the opposite halves of the eye-piece, that these images when recombined had a perfect stereoscopic character.

To effect this, Mr. Wenham's plan was, to place a sliding stop with straight edges against the lens of the objective, so that it could be turned to cut off either the right or left portion of the lens; he found those of large angular aperture would need only one-third of their diameter stopped off.

Professor Riddle, of New Orleans, proposes to accomplish the same end by inserting, just behind the object-glass, a small equilateral prism, arranged on a central axis parallel to its polished faces and transverse to the axis of the object-glass, so that it can be inclined. The hypotenuse being placed coincident with the axis of the microscope, on making the necessary inclination it will furnish the appearance of the object itself being moved, and when the image of the object has been drawn with the prism in one position it is to be altered slightly, and the slide moved so as to bring the same part into the centre of the field of view, as at first; it will now have an altered aspect, corresponding to the difference in point of view, equivalent to the number of degrees of the inclination of the prism which may vary from  $4^{\circ}$  to  $9^{\circ}$ . And if the two images of such a drawing, or photographic impression, be viewed stereoscopically, they will be found to coalesce into a stereoscopic image.

Mr. Heisch, in October, 1862, recommended, as an adapter for the object-glass, one carrying a tube that can be turned half round by a lever outside. In this tube is another, provided with a stop, that cuts off half the pencil of light emerging from the object-glass; this sliding tube, when placed in proximity to the back lens of the objective, is so arranged that the field on the ground glass of the camera shall be equally illuminated in all positions of the stop. The image is thrown on a prepared sensitised plate for the first picture, the stop is then turned round until it stands in a direction opposite to the first position; the unimpressed half of the prepared plate is then shifted into the field, and in its turn receives the second image. The two resulting pictures furnish a stereoscopic effect.

He also suggests that in objects of thickness the near surface should be focussed for the one and the more distant for the other picture.

Dr. Maddox produced stereoscopic pictures on one of the plans proposed by Prof. Wheatstone, and for this purpose he made a small  $3\frac{1}{2} \times 1\frac{3}{8}$  inch slide-holder of brass plate having a central aperture and a ledge at the top and bottom, in the direction of the length, turned up square at right angles. Opposite the centre, the ledges were pierced by a small hole about  $\frac{1}{8}$  of an inch from the angle of junction; two thin strips of spring brass being cut to the width of the ledges, about  $1\frac{1}{2}$  inches long and slightly curved, had each a small hole drilled in the centre. Two pieces of hard wood were cut into equal triangles, which were each fixed on a brass pin in such a position, that when the little triangular blocks were resting with their obtuse angles on the upper surface of the brass slide, the other end of the pins passed through the hole in the small strips of spring brass, then through the holes in the ledges, the pins being now turned up at right angles to prevent them from being carried out of the holes by their springs. An ordinary glass slide with the object set up was placed between the springs (and rested by its under surface near the edges on the upper or horizontal surfaces of the two small blocks), being clipped by them sufficiently tight to prevent falling out, when the slide was placed vertically on edge. On depressing either end of the slide, the object could be made to assume an obliquity to the objective, equivalent to the angle found between the surface of the little triangular blocks and the edge of the depressed slide when resting on the plane of the brass holder. This method answered very well for opaque objects illuminated by the Lieberkühn. The slide holding the object being first centered and focussed from the point where the least displacement of the focus appears on depressing each side equally and alternately, now depressed and re-focussed if necessary, to furnish the first picture, then similarly treated on the opposite side of the centre to furnish the second. The resultant images giving a stereo-picture; when the left depressed view is taken on the right-hand side of the plate, and *vice versa*, the images need not be reversed after printing. He also used for transparent objects Mr. Wenham's and Mr. Smith's plan for stopping off alternately in front the right and left halves of the objective by a small cap with a semicircular aperture, equal generally to half the area of the front lens, while with the highest powers, he only makes a slight alteration in the position of the object and incident light for the second picture. With the parabolic illuminator he did not succeed equally well. M. Nacet, jun., used his polished cone of glass with a central

stop on its curved base (for obtaining oblique light in parallel rays) when photographing opaque and semi-opaque objects, as the Foraminifera, &c. Dr. Moitessier recommends this plan, the light being transmitted from the mirror through the cell of ammonio-sulphate of copper, then conveyed by the condensing lens on to a disc of ground glass, placed near the apex of the cone. Dr. Maddox has lately obtained stereoscopic pictures of parts of *Pleurosigma formosum*, magnified 3,000 diameters, with Mr. Wales'  $\frac{1}{8}$ th objective and amplifier. See p. 231.

#### CHEMICAL SOLUTIONS REQUIRED.

The different solutions used in photography must be perfectly pure; this is of the first importance, and observers are recommended to purchase their chemicals at houses of known celebrity, such as Mr. Thomas', Pall Mall, rather than attempt the manufacture.

**337. Collodion.**—Supposing the collodion process to be determined on, the pyroxyline should be of the kind produced from hot acids, carrying just such an amount of water as will furnish to it when dissolved in its solvents, ether and alcohol, a fluid flowing freely, possessing considerable adhesive power to the glass, and free from fine net-like markings when dry. The manufacture of the gun cotton that will furnish these qualities requires great experience. The collodion should afford when taken from the nitrate bath, not a very thick creamy layer, but such as is commonly employed for portrait purposes. If it be preferred to make the collodion, we subjoin the formula for cotton that will yield the above mentioned film. Into a perfectly clean dry close stoppered bottle, put—

Iodide of ammonium in crystals.\*  
Iodide of cadmium, of each, 8 grains.  
Bromide of cadmium, 4 grains.

Pour on these 13 drachms of absolute alcohol or redrawn alcohol, of sp. gr. .805, shake the bottle well; when dissolved, add—

Pure ether, sp. gr. .725, 12 drachms.

Weigh out 22 to 28 grains of dry pyroxyline, add it by little open tufts to the mixed fluid, shaking occasionally, then wash down the neck and sides of the bottle with 8 drachms of pure ether. Gently

\* If the crystals of iodide of ammonium be at all damp, press them before weighing in folds of clean blotting paper.

agitate so as not to soil the neck of the bottle, and set aside in a dark cool cupboard for three or four days, or longer; then carefully pour off, without any shaking, the half into a clean dry close stoppered bottle for use, or better, into one of the 4 oz. capped pouring bottles, called "cometless." The formula given has been for only 4 oz. of collodion. The absolute alcohol can sometimes be a little increased.

**338. Nitrate Bath.**—The nitrate bath may be prepared as follows:—

Freshly distilled water, 4 ounces.

Re-crystallised nitrate of silver, 600 grains.

Dissolve; test for acidity by blue litmus paper; if acid, neutralise by a little fresh pure oxide of silver, or by a few drops of a very weak solution of carbonate of soda; dissolve in a drachm or two of water—

Iodide of potassium, 1 grain.

Then drop into it a few drops of the strong solution of nitrate of silver until it produces no further turbidity. Wash the precipitated yellow iodide of silver, pour off the washings, and add the iodide to the strong silver solution; stir, make up the quantity of fluid to 20 oz. by distilled water, and filter, or allow it to settle, then carefully pour off close, and filter the remaining portion into a small bottle. This can be used in the after intensifying process, or if filtered through a washed filter, added to the stock for the nitrate bath.

The strong solution of silver is oftener rather alkaline than acid to test paper; if this be the case, add a few drops of a solution containing 1 drop of glacial acetic acid to 1 drachm of distilled water, until the test paper remains slightly reddened, or the same proportions of nitric acid in water may be used; the latter often works remarkably well with the bromo-iodised collodion, not giving at first intense but remarkably sharp clean negatives, permitting of a rather longer exposure to the strong sunlight without staining, and considerable intensifying qualities without blocking out the finest lines. To keep up the strength of this nitrate bath, add occasionally a plain solution of re-crystallised nitrate of silver in distilled water, in the proportion of 50 grains to the ounce.

It is desirable to keep this nitrate bath perfectly free from dirt and substances likely to injure it. As there is considerable difficulty in obtaining the gutta percha baths without impurities, and the porcelain ones are sometimes too porous, a vertical glass bath with cover is much to be preferred. It is often desirable, after a full



day's work, to pour the nitrate bath into a clean bottle, allow it to settle, then carefully decant the clear portion into the bath, after it has been washed out, and filter the remainder through a washed paper filter, making up the strength, if necessary, by the 50-grain solution. In this way there is less likelihood of spots, pin holes or deposit on the transparent shadows. This bath in winter can be made stronger.

**339. Of the Developing Solutions.**—Preference is given to the formula containing the protosulphate of iron, or the double salt of sulphate of ammonia and iron, with or without a little syrup from loaf sugar added at the time of using, as recommended by Mr. Hislop, though without care this will often give fogging.

Crystallised protosulphate of iron crushed, 200 grains.  
 Glacial acetic acid,  $3\frac{1}{2}$  to 5 drachms, or,  
 Beaufoy's acetic acid of 30° per cent., 10 to 15 drachms.

The amount of 10 oz. is to be made up with pure water, then 6 or 8 grains of acetate of soda are to be added, and the fluid filtered. More iron should be added to this developing solution in the winter months. It is best when a few days old. At the time of using, to make it flow freely on the surface of the collodionised plate, add of ordinary alcohol from 20 to 30 or 60 minims to each ounce of developing solution, according to the condition of the bath. Its strength is often varied from 10 grains to the oz. to even 50 grains in ordinary work, but in sunlight negatives, it is not necessary to use more iron than in the formula.

The intensifying solution, useful for deepening more fully many of the details brought out by the iron developer, consists of:—

No. 1. Iodine, 3 grains.  
 Iodide of potassium, 6 grains.  
 Water, 3 ounces. Mixed.

No. 2. Pyrogallic developing solution, as made with acetic acid.  
 Pyrogallic acid,  $1\frac{1}{2}$  to 2 grains.  
 Glacial acetic acid, 20 minims, or  
 Beaufoy's acid, 1 drachm.  
 Distilled water, 1 ounce.

This is best when freshly made, or not more than a few days old.

No. 3. Pure nitrate of silver, 30 grains.  
 Distilled water, 1 ounce.

No. 4. Pure nitrate of silver, 20 grains.  
 Citric acid crystallised, 30 grains.  
 Dissolved in distilled water, 2 ounces.

**340. The Fixing Solutions** may be made as follows :—

Hyposulphite of soda 4 oz., dissolved in 4 oz. of water. Using it repeatedly until saturated with the dissolved out iodide and bromide of silver; but Dr. Maddox prefers a fixing solution made by dissolving about—

8 grains of cyanide of potassium in one ounce of water. It should be marked POISON. As this substance varies in its strength, the solution should be made so as to clear the plate in a gradual manner in from one to one and a-half minutes, but not so strong as to destroy the half tones. The same solution can be used repeatedly, or until rendered, by using, too weak. It should not be kept exposed to the air.

#### PRACTICAL MANIPULATION.

This is naturally divisible into three distinct stages : 1, obtaining the image on the sensitised plate ; 2, rendering it visible ; and 3, obtaining a print upon paper.

**341. Cleaning the Glass Plates.**—The glass plates, whether of “patent plate,” which is the best, or of “polished flatted crown,” are first to have the sharp edges removed by a grooved roughening stone sold for the purpose ; this is best done under a gentle stream of water from a tap, that the particles of grit or dust may be carried away : the plate is then dropped into a clean pan containing a hot solution of washing soda in rain or soft water. After lying in this for a little time, they are singly washed over back and front with a pledget of tow and saturated solution of washing soda, then dropped into clean hot soft water. When all the plates have been treated in this way, they are taken out to drain, the water thrown away and fresh hot water poured into the vessel. The plates are singly dipped under the surface of the clean water, then wiped with chemically clean linen cloths, such as old napkins, one covering the left hand in which the plate rests, the other being used to dry and polish the plate. These cloths are *not to be washed with soap and water*, but to be well washed out in *hot soft water*, containing a little soda, then well rinsed in fresh water and dried.

It is advisable to keep a stock of plates thus partially prepared. To further clean them, examine the plate along the edge, and if any very slight curvature exist, let this be taken as the surface on which the collodion is to be poured. Select three chemically clean dry cloths, fold one into double thickness, and on it hold the plate in the left hand, face down ; with one of the other cloths polish well the back, breathing on it from time to time ; then turn it face uppermost, have a little old collodion which may be slightly weakened with alcohol, place a pledget of clean cotton wool in a small cleft stick or whale-

bone, dip it into the old collodion, pass it quickly and well over every part of this surface of the plate. With the same cloth that polished the back, rub this off briskly, then with the other clean perfectly dry cloth finish off the polishing, so that when breathed on, the surface may present a uniform dull appearance without any streaks; set it face down on a clean sheet of foolscap paper, or in a grooved well-closed plate box, the finished faces all looking one way. Thus prepare the number of plates required for immediate use. If to be kept a few hours, wrap them up in another fold of paper, place them in a dry drawer, always noting which is the perfectly cleaned surface. If of a larger size than 6 inches square, it will be more convenient to clean them on a proper polishing board. Cleanliness in this, as in the succeeding stages, is absolutely requisite. If no old collodion be at hand, a polishing liquid may be made by—

Howard's precipitated magnesia, 20 grains.

Strong liquor of ammonia,  $\frac{1}{2}$  drachm.

Alcohol, 2 ounces.

This, however, requires to be most carefully removed, in the cleaning, from the edges of the plates, or they would soon render the bath alkaline. Or the method adopted by M. Boetter may be adopted for cleaning chemical glasses which is *strongly recommended* by Mr. Carey Lea :—

Common sulphuric acid, 1 oz.

Bichromate of potash, 1 oz.

Water, 1 pint.

The glasses are to be left in this solution for seven or eight hours, their surfaces being entirely covered by it. They are then to be rinsed well beneath a tap. The same solution answers many times. If the plates are handled, it is as well to see there are no cuts or abrasions on the fingers, for this fluid to come in contact with.

**342 Arranging the Camera.**—Supposing the portable form of apparatus recommended by Dr. Maddox be selected, we proceed as follows :—A room is to be chosen which has a window with a south-west aspect, or at least one where the sun's rays enter during the greater part of the day. The end of the apparatus is placed outside the opened window in such a manner that the face of the prism is directed at right angles to the incident rays; the legs of the triangle are set apart so that the whole stands firmly on the floor. The object being fixed, it is first carefully examined under the compound microscope, and if of any depth, the part in strict focus when the best general character of the object is attained, is well noted. The objective likewise being selected, is to be screwed into the neck of the microscope,

and the achromatic condenser placed in the fitting on the under-surface of the stage-plate. The blackened card diaphragm, according to the size of the field desired, is to be fixed in the diaphragm frame that works to and fro in the cut in the back part of the camera chamber, and the prism so turned that the sunlight is thrown on the ground-glass screen. Then bring the objective into focus as when the object slide is in situ. The value of the prism is now apparent, for upon standing with the face towards its convex surface, and turning it on its own parallax motion, an intense image of the sun will be soon found, as it were, on that surface: the prism is then to be so arranged that the reflected images from the lens or lenses of the achromatic condenser and of the objective, fall centrally on the sun's image. If the field on the ground glass now appears equally bright in all directions, the achromatic condenser is slightly altered, to see whether any increase of illumination accompany the change; if not, it is returned to its previous position. Should the images not all fall into the line of the image of the sun, seen on the surface of the prism, some alteration must be made in the part which seems most at fault; but when they all fall into it, and the distance of the prism is such that its converging rays just cross before reaching the object, the probabilities are that the centering is correct. If the prism will not carry a cone of light sufficiently large and bright for the lowest powers, as 3 inches, then set it aside and try the plane mirror. The object, if on the ordinary  $3 \times 1$  inch slide, is now placed on the stage, the camera bellows-body shut up; the whole apparatus is covered with a large focussing cloth of black cotton velvet, except the parts to be exposed to the light, the right hand is applied to the slide, and the eyes directed to the ground-glass screen under the focussing cloth; the object is now placed (as nearly as possible) in the centre of the field, and the approximate adjustment made. Alter the rack-work of the condenser and the prism until the best effect is produced, for the proper position of the condenser is a very important one, and often more trouble to arrange than the focus of the object-glass. The object being well centered, the field perfectly bright and uniform, see that the velvet collar around the microscope tube *abuts closely* against the aperture in the door of the vertical frame; now withdraw the camera along the base-board from the near end, and closely watch the enlargement; when this is determined on, fix the camera by the wire pins to the nearest hole in the two wooden guides. Supposing this to be at an easy working distance,—watch the image on the ground glass through the focussing eye-piece; turn the graduated milled-headed screw of the fine motion until the same point as was previously noted is brought into a sharp focus. Should the over-correction of

the lens not have been carefully corrected by a back lens, for the low powers, as previously advised, proceed to make the necessary allowance, which experience has determined, by turning back the screw of the fine motion, the number of divisions or parts required as marked on the milled head. If not known, commence the experiment as before stated, p. 255, and note the particulars. A card covered with black cloth or velvet, with its lower edge turned at right angles and deeply notched, is now rested on the stem of the microscope against the end of the achromatic condenser, facing the prism, and this latter protected by a thick fold of chamois leather from the sun's rays. Care must be taken that neither surface of the prism is soiled by vapour or finger marks; nor must the concentrated sunlight be permitted to remain longer on the object than is actually required in focussing, or it may become uncemented, and if not injured, it may slip completely out of the field.

This apparatus, if used in the open air, could have the microscope end to move instead of the camera, but this method is very inconvenient, when used near an open window, from the difficulty at times to place the prism outside the plane of the window or in its best position.

If the higher powers be used, needing the screw adjustment for the correction of the error introduced by the thin glass cover, we find it best to make this as nearly as we can when examining the object in the microscope, then testing, with the collar set to that figure, the image on the ground-glass screen. If the image here seems moderately sharp, under the best focussing, a trial is made by shifting the collar a very little and watching the appearance of the image; sometimes a very trivial alteration will bring out fine markings much more distinctly; the focus, if this be the case, will also often require readjustment; but before making this, it will perhaps, if only trifling, be as well to test a plate, when, should the negative be found defective in the parts most sharply focussed, try another, withdrawing the objective by the milled-headed screw. It is often in this way that the qualities of an objective are rendered evident. It sometimes becomes very troublesome to ascertain these points for a variety of objects and covers. Assuming that the plane of the greyed glass screen, and that occupied by the sensitised plate, are *strictly* alike, if the second image be out of focus, test again with the apparent necessary change learnt from a close examination of the negative, and the image on the screen. When once correctly found, note the division of the screw collar and the distance in inches at which the camera stands fixed by the pegs, and seen by the figures on the guides, as necessary for that objective used at the same

distance with sunlight, and for objects covered by glass of that particular substance.

Dr. Maddox remarks, that when the edges of objects under the higher powers present, on the grey glass screen, a faint tint of claret on the one side, and of apple green on the other, that great sharpness will often exist in the negative; the errors of the pairs of lenses balancing one another as regards the actinic focus. The roughness of the screen will not, in all cases, permit of the eye determining under sunlight the best focus for the minute markings, and some fine diffusing surface must be chosen, as a well-washed sensitised collodion plate either previous to drying, flowed by a solution of tannin or albumen, or not,—or the surface of plate glass covered by fine weak starch paste recommended by Mr. Carey Lea, or the serum of milk, as occasionally used by Dr. Maddox; some, as Dr. Woodward, employ plain glass, but if used without a coloured medium intervening, there may be some risk to the eye in working with the lower powers. The object can likewise be focussed through a parallel polished plate of blue glass. Nothing hitherto has been found more generally serviceable than the *finely* ground surface for ordinary work.

Should the object be situated any distance from the thin covering, *i.e.*, have much of the mounting medium included within that space, although the objective may visually appear to work fairly through the depth, it is seldom that the negative of the image proves satisfactory. It is far better to remount the object, or select another. Indeed, for the finer work, it is advantageous that the objects should lie closely on the under-surface of the thin cover. Diatoms and such bodies may be dried on it and photographed, or after drying they may be placed on the drop of balsam warmed on the glass slide; this may likewise be thin, and certainly should not be thick. If there be any vibration from unsteadiness of the apparatus, or from wind, the results will be unsatisfactory.

**343. Inserting the Plate.**—The suitable sized plate of properly cleaned glass being selected, and the materials required set at hand in the dark room or portion of the chamber darkened off for this purpose, and lighted by a yellow light or a small oil lamp with yellow glass shade, the plate is held by the sides between the fingers and thumb of the left hand, face down, the back wiped carefully with a *dry* wide flat camel-hair wash tool, to remove small particles of cotton or dust; then taken hold by a pneumatic holder in the centre, and the face dusted over with the brush. Before taking the holder in the left hand, see that the neck and lip of the collodion bottle are perfectly

free from any particles likely to be carried on to the plate by the stream (the finger is commonly passed over these parts to clear them away), pour the collodion with a steady flow on to the plate, a little nearer to the left hand than its centre ; while flowing, depress the lower and upper left corners, gradually, to bring the collodion fairly to their edges, at the same time that the pool is being increased by pouring, and then lower the plate to flow the fluid to the right further corner, and pour off at the lower one into the bottle, resting the sides of the angle on the lip, and rocking it to keep the plate slightly inclined ; drag off, as it were, the lower part against the neck of the bottle, close it, and hold the plate horizontally by the pneumatic holder for 10 seconds to half a minute, or even more, according to the setting quality of the collodion ; if this be slow, it will be better to rest the holder on some flat place or shelf, that the warmth of the hand may not cause unequal evaporation. Once seeing this operation well done is better than a lengthy description. Detach the plate from the holder and place it on the fluted glass or silver wire dipper, to be plunged at one gradual stroke into the nitrate bath. Here it is allowed to remain for one minute, then raised and lowered several times so as to wash the surface well, and permitted to remain in the bath for one or two minutes longer, when the dipper with plate is to be steadily withdrawn ; the plate removed, and rested by its lower edge on a pad of clean blotting paper, the dipper returned to the bath, and the back of the plate wiped with a pledget of clean rag, being gently steadied by the top corners between the thumb and fingers of the left hand, which must be dry and clean. Open the back of the plate frame, pl. LIV, fig. 331, and place with the right hand the plate into the frame, which should be dry and free of dust, face downwards, close the back, cover the frame with a large piece of black calico, carry its lower edge down to the apparatus, and rest it against the wall or table. Re-adjust the prism, remove the focussing screen, having glanced at the image on it, set the covered card against the achromatic condenser, pass the slide holder under the focussing cloth, into the position of the greyed screen ; *lift carefully* the shutter of the frame, the hands being under the cloth :—let all remain for a moment or two that vibrations may cease, snatch away the card without shaking, and replace it quickly, allowing a period from half to twenty-five or thirty-five seconds for the image to be impressed ; the time must be learnt by practice ; close the shutter gently, withdraw and replace the frame in the cloth, pass the focussing screen into its place, again snatch away the card and observe the image, then cover the prism and return with the slide holder to the dark room, and proceed to develop the picture. The reason for the re-observation of the image is, to see if the object and

its focussing have not been in any way deranged, so that if the development brings out a good image, it can be repeated without the necessity of returning to the camera before the second plate is ready.

**3-4-4. Developing the Image.**—Let us suppose the plate to be a small one. First see that the nitrate bath is *carefully placed out of the way of all splashes*, pour into a clean developing glass an ounce or more of the iron developing solution, add the necessary quantity of alcohol, or syrup and alcohol, and mix; remove the plate from the holder, rest it face up on a levelled developing stand set in a large basin or pan, clip the left-hand opposite corners between the finger and thumb, and commence the second step by flushing the surface with some of the iron solution; tip the plate about, that the liquid may quickly flow up to all the edges, then move it gently about on the top of the stand; the light from the protected lamp or admitted through the yellow glass window falling nicely on the surface, watch for the appearance of the image; this, if all be correct, will increase steadily up to a certain point, when, if left longer, the plate will begin to grey all over; *just before this would take place*, or according to experience, tip up the plate to throw off the developer, flush the plate well with water from a jug or tap protected by a piece of flannel tied loosely over it, to remove all the iron. Now examine the plate carefully by transmitted light from the window or lamp with yellow shade, and judge if it be worth continuing the other operations; reflush again with water, pour off, and now pour on the fixing solutions—the cyanide of potassium is to be preferred—pour this along the thickened part of the collodion, let it pass over all the plate, and in less than a minute, the plate will be cleared of the unaltered bromo-iodide of silver. Wash well front and back with clean common water, drain the plate for a moment, and pour on it along the edge sufficient of the solution of iodo-iodide of potassium to well cover the surface; allow this to remain on the plate until the grey colour of the image passes to a warmer tone (two or four minutes or more) pour off the fluid, examine it quickly with a hand magnifier by ordinary light; if it now has the appearance of being in focus, wash the plate well with common, then with clean fresh rain or distilled water; let this stand on it whilst you pour into a *clean* developing glass about  $2\frac{1}{2}$ , 3, or more drachms of the pyrogallic solution; add to this, from 6 to 10 drops of the 30-grain nitrate of silver solution, and 2 to 4 drops of the nitro-silver solution, mix these by twirling the hand holding the developing glass, pour off the water from the plate, and carefully pour on along the edge or corner, this mixed fluid, so as to flow to the edges; rock as before: after a brief period, according to the appearance of the image, return the fluid to the developing glass



and pour on again ; repeat this several times, just holding the plate in the intervals between the eye and lamp, to judge of the increased intensity, which, when it appears sufficient, should in the darkest parts permit the flame of the lamp or yellow window, to be just seen through. Now wash well with water, finish with a little soft water ; with a small towel wipe the back, and set the plate to drain in a plate rack, attaching to the lower corner a small piece of blotting paper, or the plate can be dried off at once over the lamp. It is sometimes difficult to judge of the real intensity gained under this treatment, when the image is observed by yellow light, therefore, after the flowing over of the iodide of potassium solution, the remainder of the operations can be conducted by the direct light of the small lamp, or any moderate diffused light.

Should the development have been carried a little too far, or should the fine transparent markings appear thickened or clouded, before setting up the plate to drain, flush it with a mixture of equal parts or the cyanide and iodide solutions and distilled water, then well wash. Under this treatment many of the minute spots and half-toned points become remarkably brightened. Some prefer to intensify before using the cyanide solution, by, first, under non-actinic light, after the iron developer has been *well* washed from the plate, pouring on the pyro solution, with a little alcohol, returning it to the developing glass, then adding the mixed silver solutions and repouring on and off the plate, until the image has been brought up to the necessary intensity, when it is to be well washed, and then treated with the hypo-fixing solution or the cyanide. Or the operator may proceed to intensify after well washing off the iron solution, after clearing by cyanide or hypo solutions, using the pyro and silver solutions, without the previous use of the iodo-iodide of potassium solution. The fixing solutions are returned to their vessels (short wide-mouthed bottles or jugs are convenient), and can be used over and over again, adding a fresh quantity as occasion may require ; but the cyanide solution must not be left exposed, for it soon loses cyanogen, and the vapours are deleterious. Keep the hands continually wiped in these operations. If the plate, after the application of the iron solution and cyanide solution, have the appearance of under exposure, the image indistinct in detail—or of being over exposed, the image of a too dark and uniform character throughout—or of being out of focus—it will not be worth while to proceed to further develop it : wash it and carry it to the light, examine it with the hand magnifier, as some part, not that specially focussed, may appear the sharpest and serve to indicate the alteration required on re-focussing. If any extraneous light should have entered, through defects in the

camera or at the vertical frame, or from the slide-holder, or when preparing the plate in the darkened room, or before applying the fixing solutions, or if the nitrate bath and chemicals be not in perfect condition, the plate when cleared will appear fogged or misty, and not yield good prints.

Generally it is advisable, when the negative appears correct, to take a second one under the same arrangements, only re-arranging the prism; seldom can the exact relations be re-established, and after the rendering of another negative, it may be found that the little alteration in the illumination, barely visible on the screen to the eye, has given a still more perfect character to the image, or further developed some of the finer markings.

**§15. Of increasing the Intensity of the Negative.**—There is much difficulty in obtaining a clean dense negative, which shall preserve distinctness in the finest markings. When the attempt is made to procure greater intensity by the intensifying processes, the fresh deposit of silver, with the shrinking of the collodion in drying, will often so completely close up these lines, that their definition becomes lost in the print. To endeavour to still preserve these and add printing intensity to the negative, some employ a solution of bichloride of mercury. Dissolve in 2 oz. of distilled or soft water, 12 grains of the bichloride of mercury or corrosive sublimate; label the solution POISON. After developing with iron, washing and continuing the development with the silver and pyro solutions, fixing, and re-washing, the plate is flushed with the sublimate liquid (which is allowed to remain on, until the image becomes of a dark grey colour if the solution be used weaker, 2 grs. to the oz. of water), then well washed, and recovered with a weak solution of iodide of potassium from 1 to 2 grs. to the oz. of water; this will give the image a dirty grey or green tinge, which will often dry of a darker colour. The bichloride can also be used after the iodide of potassium solution, taking care to wash the surface well before applying it, then again washing off with water, the plate may be covered with an old weak solution of hyposulphite of soda, or a few drops to half a drachm or more of the strong liquor of ammonia in half a pint of water, or sulphide of ammonium in water. Some employ iodide of mercury dissolved in iodide of potassium, and thus secure its advantages by one operation. In cases in which the bichloride has been used to add to the intensity, the negatives, when dry, often present a remarkable sharpness; but it is no uncommon thing to find that when the plate has been dried, spontaneously even, the moment it is handled the collodion flies and cracks often into the image; to prevent this it is requisite to pour over the plate, after the last washing, a

weak mucilage or gum water. In this case care must be taken to well dry the plate prior to varnishing, as gum is to a small extent an absorbent of moisture.

In the journals and manuals on general photography various methods are set forth to endeavour to procure by one operation sufficient intensity to print from. Mr. M. Carey Lea strongly recommends gelatine soaked, the water poured off, then acted on (without heat in all the operations) by sulphuric acid, the acid to be taken up by the gradual addition, when cool, of clean iron filings or thin iron wire, and the excess of acid finally removed by the acetate of soda. Others have proposed the solution of gelatine in acetic acid or nitric acid and the addition of this, from a few drops upwards, to the ordinary protosulphate of iron or ammonio sulphate of iron developer, without the acetic acid (Dr. Towler's method). Some use honey or a little albumen added to the pyro-acetic and silver solution for the same object.

**346. Varnishing the Plate.**—When the plates are dry, clean off the edges with a damp cloth held on the forefinger nail, wipe well the back, and hold the plate before a clear fire until moderately warm to the back of the hand; take it by one corner and pour on the varnish (Soehnée is very good). Allow it to flow freely over the surface and remain for half a minute or less on it, then pour back the surplus into the bottle from one corner, not rocking the plate; let it drain a little, then hold the plate towards the fire vertically, the edges from which the varnish was poured being downwards, and wipe them with a piece of rag or tissue paper to prevent a thickened line being formed and extending inwards as the plate dries. If intended for enlarging, it is far better not to varnish the plate in any way; but to prevent the surface from being injured, it may be flowed with weak albumen, then dried, and plunged into a dish of alcohol as advised by some.

**347. Of Cleansing Old Plates.**—The soiled and used plates can be cleaned by the fresh use of washing soda; those varnished should be allowed to soak in a very hot strong solution of this substance, or rubbed with a pledget of tow dipped in nitric acid; or treated by Mr. M. Carey Lea's method. If they are to be used again they must be cleaned with great care.

The third stage in the manipulation closes with the production of the image on paper, technically called Printing.

#### PRINTING.

The negative, if it be preferred, can be handed to a professional photographic printer, who, however, should be acquainted with the

character of the object, or have its chief points named to him ; otherwise a print may be returned bearing anything but a semblance to the real appearance of the object, as seen in the microscope ; the tendency generally being to over-print and render a delicate object heavy and out of all character. We shall complete this chapter by offering such instructions as may at least enable the amateur to print for himself.

**348. Preparing the Paper.**—Select albumenised paper, the best procurable, either Rive or Saxe, and such as is used for the finest cartes de visite. Cut the sheet into six equal parts or to the size convenient for sensitising, or according to the size of the negatives, taking care not to soil the surface with the fingers.

Take the paper by the diagonal corners, bend it slightly back and lower it gradually, without any stoppage, albumen side downwards, on a solution of nitrate of silver 60 to 80 grains to the ounce of water, and about one drop of nitric acid to four or six ounces of liquid. Be careful that no air bubbles are confined beneath the paper. To ascertain this, lift the corner by a pair of bone forceps, allow the paper to remain from one to two minutes for the 80 grain solution, and three minutes for the 60 grain solution. The object is to form a chloride of silver as much as possible on the surface of the albumen.

Pin up to drain, and append a piece of blotting paper at the lowest corner. When surface dry, if required at once, the drying may be hastened by placing the papers in a box lined with blotting paper and heated by a warm clean brick or corked jar of hot water.

The paper must be prepared in non-actinic light, and can be preserved for future use in a preservative case sold for the purpose.

The negatives are wiped on the back, placed face up in the printing frames, figs. 332 to 335, pl. LIV, the sensitised paper put face downwards on them, then covered by a pad of red blotting paper or cloth, and the back of the printing frame properly closed. These frames, covered by a dark cloth, are carried to the window ledge or table at an open window, and placed so as to receive the direct sun's rays. After the edge of the paper is seen to be well browned or bronzed, the back of the printing frame can be carefully opened in diffused light, the print quickly examined, the back reclosed, and the frame returned to the same position if not already sufficiently printed. When the printing is finished float the prints face downwards on a large flat dish of clean rain water, then on common water in another dish ; afterwards plunge them under water in another deep vessel,

allow them to remain for five or ten minutes, occasionally stirring them about, and relay another set. They are now ready for toning. Some plunge them into water and change the water several times, but in this case the backs are wetted and the unchanged nitrate or chloride of silver admitted into the pores of the paper, which is not advisable. Before placing the prints in the toning solution it is as well to let them drain against the sides of the dish, if of small size; if larger, to at least wipe over the front and back with a glass rod, so as not to pass them into the toning bath in a very wet state.

Sometimes the printing is better if conducted in a north light, or under ordinary daylight instead of sunlight, according to the character of the negative.

**349. Toning Solution.**—The toning solution is prepared as follows:—

8 drachms of distilled water.

$7\frac{1}{2}$  grains of chloride of gold.

If not likely to use the solution within a moderate period, 1 drop of hydrochloric acid is to be added to the above solution, which must be kept in a stoppered bottle in the dark.

Pour one drachm of the gold solution into a clean developing glass or measure, and add one ounce of distilled or soft water. Into another clean glass vessel put half an ounce of soft water, and 5 grains of bicarbonate of soda. Part of the soda solution is to be added to the gold gradually, stirring during the time. The solution is to be tested with blue litmus paper. The addition of soda solution is to be cautiously continued, until the paper is no longer reddened. A drop or two more of the soda is then to be added, and the neutralised solution of chloride of gold poured into a clean small flat dish, and mixed with about 8 ounces of soft water. Set this near to the window screened by the yellow curtain or glass. Remove the washed and drained prints from the dish, and pass them into the toning solution. Here they are to be kept in motion: as they appear to darken, just lift the curtain aside and note the tint they have assumed by daylight, but they must not remain exposed to the light any time, or the white parts will be injured. The other dishes should likewise be attended to and covered over with a sheet of paper to keep the light from them. When the prints appear to have the desired tint, from a warm brown, through neutral tint to nearly black, begin to remove the most toned, wipe them with the rod and pass them into a dish of clean water. The quantity of the toning solution prepared, must be in proportion to the size and number of prints, about 1 grain of gold to one full sheet of paper.

**350. Another Toning Solution.**—One grain of chloride of gold,

or 1 drachm of the solution, is to be neutralised with bicarbonate of soda in 9 or 10 ounces of soft water, then half a drachm of the crystallised acetate of soda is to be added. This is to be used the day after making; it keeps well, and can be strengthened by adding freshly made solution prepared somewhat stronger. Occasionally the neutral or alkaline solution of gold-bath will not act; but if the dish be set over a jug or basin of hot water, the toning action will commence, or a few drops of the chloride of gold may be added. Good toned prints have also been produced by using the weakened neutral solution of gold and soda for the next lot of prints, adding some fresh solution of gold. Other toning solutions are made with bitorate, or phosphate of soda; also with acetate and chloride of lime.

The unaltered chloride of silver has now to be removed from the paper.

**351. Fixing Solution.**—The fixing solution is made by putting into a gutta-percha dish, kept for this purpose only, according to the size and number of the prints,—

2 ounces of hyposulphite of soda to 8 or 10 ounces of soft water.

As a precaution, in case the hyposulphite should be acid, a small lump of chalk or whiting is to be added. Remove the prints from the water, drain well, if convenient, against the sides of the dish, then pass them singly into the fixing solution, keeping them there, in the case of a thin paper, for 10 minutes, and a thick paper for 15 minutes. They must be kept in motion. These different processes should be conducted more or less continuously so as not to lose time.

When the prints are removed from the hyposulphite, drain well, then pass them into a vessel of clean water, which should be changed often during the first hour, draining completely each time. They may then be left for 6 hours or longer, the water being changed every half hour, or kept under a gentle stream of water. They are to be finished by soaking them for a short time in hot water. After this they are pinned up, and a piece of bibulous paper attached to the opposite end, so that the fluid may be drained off quickly. The hyposulphite solution should be used when freshly made.

**352. Of Mounting the Prints.**—The prints when dry are unpinned, pressed in a book or ironed on the back, then trimmed and mounted on card or thick paper, first laying them in the folds of a damp cloth, and the cards in another damp cloth. When the prints lie flat, they are to be removed to a clean surface of paper, and a stiff brush with thick mucilage from dextrine, or thick white starch paste, passed once over the back of the photograph, which is then placed on the card in the desired position. A clean fine cloth is passed over it, and

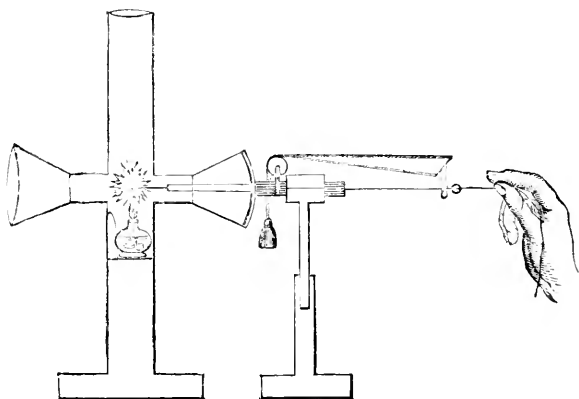
the print pressed equally all over. Some use thin Scotch glue instead of mucilage.

When the cards are nearly dry, they should be passed through the rolling press.

Many useful hints on various subjects connected with microscopical photography will be found in the Photographic News Almanack and the British Journal Photographic Almanack for the last few years.

**353. Magnesium Light.**—Those who wish to devote their evenings to the production of negatives of microscopic objects may employ the electric, oxy-hydrogen, or magnesium light. Mr. Highley has introduced two forms of Electric Regulator, one being adjusted by the hand but with provisions for keeping the point of light central; the other is self-adjusting and is excessively sensitive. A third form is cheaper than the foreign instruments hitherto employed. The oxy-hydrogen lamp is the same as that described under the Magic Lantern apparatus.

Dr. Henry Morton, of Philadelphia, has likewise made a considerable improvement in magnesium lamps, by adapting a metal chimney, wide enough to prevent the flame from touching the sides; the bottom is closed up either by metal or by being placed in a dish of water. Opposite the ignited wire is a round hole in the side of the chimney through which the air enters, and striking against the flame increases its brightness and intensity in a very marked manner, thus effecting equal illumination at a much less expense. Following up this idea for ordinary use, Dr. Maddox has con-



structed an apparatus for using short lengths of wire in photomicrography, and which will be best understood by a reference to the figure. A stout tin tube, about 8 inches high and  $1\frac{1}{4}$  inch

bore fixed in a wooden base, has at opposite sides at the exact centre of the microscope or camera tube, two apertures cut  $\frac{3}{4}$  of an inch in diameter, and two tubes 1 inch in length soldered in; in these short tubes slide the tubes of two funnels of tin,  $3\frac{1}{2}$  inches deep and  $2\frac{1}{2}$  in width, blackened inside. Again at right angles to the apertures of the two short tubes are two circular holes. Against the outer rim of the funnel nearest the stage is placed the plano-convex condensing lens, and against the rim of the opposite funnel a hemispherical concave reflector with a central aperture. Beneath the short tube carrying the first funnel a portion of the eight-inch tube is cut tongue shape and turned in to support a narrow spirit-lamp. An arrangement is made in the support holding the reflector by which a small tube can be passed through the central hole in the reflector, and by allowing a weight to fall steadily a short distance, a wire piston is carried along the tube, and projects the short piece (3 inches) of magnesium wire as it burns away, the ignited point being in the centre between the two funnels and at the foci of the condensing lens and silvered reflector. This plan requires a little experience to allow the necessary motion of the hand to compensate for the rate of burning, and might be constructed as self-acting, but practically it answers very well, and is easily made.

#### **354. Photographs of Microscopic Objects for the Magic Lantern.**

—Although no means are yet known by which a minute object, magnified by the higher powers of the microscope, can be thrown upon a screen so as to be seen by a number of persons at once, almost the same result has been obtained by magnifying a photograph of the object in an oxy-hydrogen magic lantern. It may not be misplaced to say a few words on the negatives best suited for enlargement, and the mode of enlarging to a moderate size. The negative should be clear without stains, and if containing only a single object—or objects—separated, the field should be only sufficiently dense not to allow any light to pass through in the period of time necessary to secure a reversed copy or positive on glass. To effect this there are several ways. If to be of the same size, a sensitised, albumenised, or tannin prepared plate, dry, has the negative laid carefully face down on the prepared surface, and fixed as in a printing frame, or held very tightly, then exposed to ordinary day-light for a few seconds, or else for a longer period opposite a fish-tail gas-light. When impressed the negative is removed, and the image developed in the manner employed for the kind of film used. A very fine deposit is requisite, therefore the development should be gradual; great diversity of tone is procured by using various



articles in the developer, or following its re-application, as honey, raspberry syrup, &c., or the image when cleared by cyanide of potassium or hyposulphite of soda and well washed, toned by a gold-toning solution.

If to be taken on a wet plate, a proper copying camera or two draw cameras are commonly used: the negative, face towards the interior of the camera, is placed in the ordinary camera slide, and this inserted in its place and opened. A portrait combination is fitted to the opposite end of this camera if the negative is to be in any way enlarged,—if not to another camera, and the front lens made to face the negative; the two cameras are then fixed face to face, and the light around the aperture of the lenses and the junction with the additional camera, made absolutely light-tight: the cameras thus fixed to any board are placed so that the negative faces a north light; by means of the rack and pinion of the combination, and the draw-part of either or both cameras, a sharp image of the negative is to be formed on the greyed glass of the second camera, and then received as in the ordinary manner on the prepared plate: a short exposure only is needed. It is as well to limit the field by placing a piece of thick black paper with the necessary size or shaped aperture in it, on the back of the negative before placing it in the slide; care should be taken to secure the negative in its position in case of accident. Or a copy can be made by placing the negative in a vertical frame supported on a table near an open window, and a large white card or mirror placed a little distance, at an angle behind it, so as to illuminate the surface equally by transmitted light, and the ordinary camera used as in copying engravings or pictures, care being taken that the reflected light from the screen is not thrown into the lens as well as transmitted through the negative. A proper copying camera is the best. In enlarging, some employ a special reflector, when the position of the negative must be arranged with care. The positive thus obtained can in its turn be made to furnish a second negative of a similar, larger, or smaller size.

As these photographs abound in delicate detail, an oxy-hydrogen or electric lantern with achromatic lenses is necessary for their proper display. The lantern and arrangements for producing the light are shown in plate LV, fig. 341. The lantern should be made of old seasoned mahogany, so that warping may not be produced by the very intense heat of the lime light. Behind the spring stage, which carries the photographic slide, M. T. T. Taylor has placed a combination of lenses,  $3\frac{1}{2}$  inches in diameter, called "the condenser." (*See* paper in Reports of the British Association) The

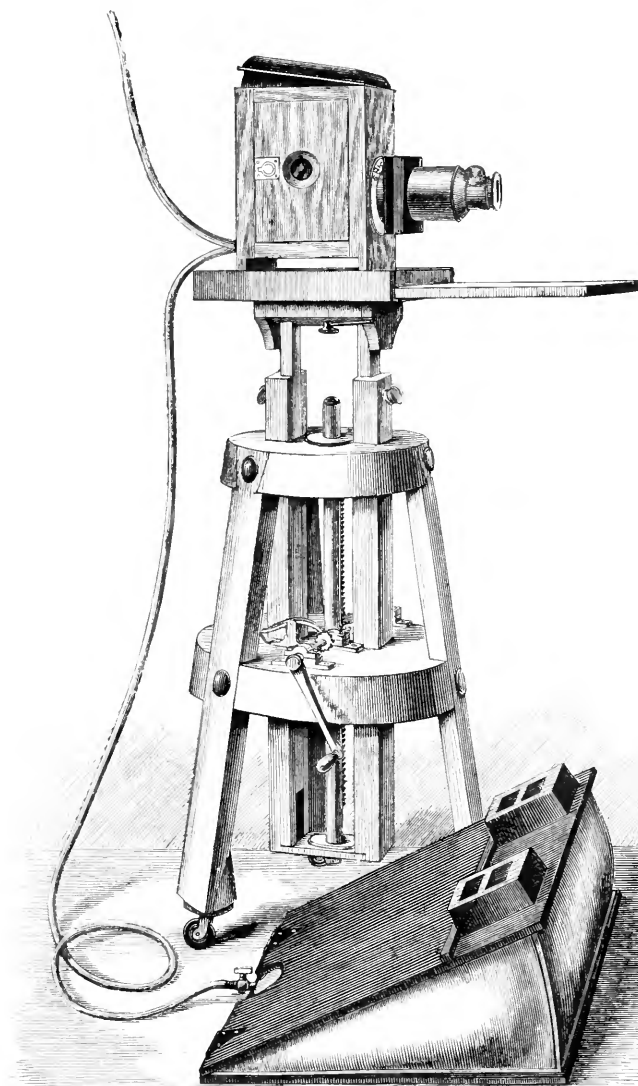
object of this arrangement is to collect and concentrate the light emitted by a cylinder of lime rendered incandescent by an ignited jet of oxy-hydrogen gas, upon the surface of the photograph, through which it passes, and then converges upon an achromatic combination placed at a proper focal distance in front.\* The rays on passing onwards diverge, and the enlarged shadow of the photograph is projected upon an opaque or transparent screen. By this means all the details of an object less than a pin's point in size may be shown with perfect definition, twenty feet in diameter. The hydrogen may be obtained from any house gas-supply by simply connecting the tap of a gas bracket by a piece of flexible tubing with the hydrogen tube of the jet. The oxygen is obtained by heating a mixture of chlorate of potash and oxide of manganese in a proper retort, and collecting the gas in a wedge-shaped gas-bag, after passing it through a washing bottle to purify it. The stopcock of the gas-bag is connected with the oxygen tube of the jet by flexible tubing. The jet is so arranged that it is impossible for any accident to occur in the shape of an explosion, the gases only being combined at the extremity of the jet. When house gas is not attainable the jet of oxygen may be forced through a spirit flame on to the lime ball, or if a small disc of seven feet in diameter is considered sufficient, such photographs may be shown by means of a paraffine or other hydro-carbon lamp, if the triple condenser and single achromatic lens recently introduced by Mr. Highley be employed.

The most intense light is obtained by replacing the house-gas (carburetted hydrogen), with pure hydrogen and burning both gases under an increased pressure, and mixed in a suitable jet, just before being forced upon the lime ball.

Mr. Robert Grant, of New York, has remedied the inconvenience of the usual India-rubber gas-bags by constructing cylinders of iron of about one cubic foot capacity, and charging these by means of condensing pumps with the gas to the pressure of 30 atmospheres, being equivalent in contents to six of the gas-bags generally employed. The advantages over the gas-bags are, that these reservoirs are cheaper, last longer, and keep the gases any length of time undeteriorated. They are always ready for use, the cumbrous pressure boards and weights are dispensed with, and they are free from danger if purchased from a maker that can be relied on. Every bottle should be subjected to a suitable test before it is sent out. The drawback to this arrangement is that the

\* Mr. Highley makes a combination of three lenses  $3\frac{1}{2}$  inches in diameter into a condenser.

Fig. 341.



Oxyhydrogen lantern, with gas bag, &c., as arranged by Mr. Higley for throwing the photographs of microscopic objects upon a screen. p. 277.



bottles must be sent to the manufacturer to be filled, as the gases are forced into them by a costly pump requiring special arrangements. Mr. Highley, who has given particular attention to the improvement of the magic lantern and all its appliances, has quite recently undertaken the production of these "condensed gas bottles," and the supply of oxygen and hydrogen gas. They are made of wrought iron fitted with lever valves of very careful construction, and are tested to withstand more than double the pressure they will ever be subjected to in practice. He finds that it reduces both the bulk and the cost of the oxy-hydrogen apparatus very materially. It promises to make a most convenient and efficient arrangement for the lecturer, and may also be used for projecting a powerful beam of light into the cavities of the human body as for laryngoscopic examinations, &c. *See* Mr. Highley's paper read before the Society of Arts, January 4th, 1863. Mr. How, of Foster-lane, also makes the requisite instruments and apparatus.

---

A list of books on photography of value to the practical operator will be found at the end of the present volume.

## PART V.

OF THE HIGHEST MAGNIFYING POWERS YET MADE, AND OF THE BEST METHODS OF USING THEM—NEW METHOD OF PREPARING SPECIMENS FOR EXAMINATION WITH THE HIGHEST POWERS—NEW VIEWS CONCERNING THE STRUCTURE, GROWTH, AND NUTRITION OF TISSUES AND OF LIFE—OF THE STRUCTURE AND ACTION OF A NERVOUS APPARATUS.

IN this the last section of my book, I propose to consider how objects may be most satisfactorily examined with the aid of the highest powers yet made. I shall venture to describe in detail the special method which I have found it necessary to employ in my recent investigations upon the minute structure of various textures and the changes which take place in the course of growth. By this process, sections of any tissue may be prepared thin enough for examination by powers magnifying upwards of 5,000 diameters, and the vessels may be injected and afterwards displayed in the same preparations.

This part of the subject introduced for the consideration of the more advanced student, should not be studied by beginners until they have honestly gone through the tables at the end of the volume, and have perfected themselves in the various operations there indicated. When the elementary principles and practical details have been thoroughly mastered, the observer may practice the process of staining tissues, p. 107, and endeavour to make exceedingly thin sections, p. 80. In this way he will be gradually led to attempt to make original investigations, and, in the course of his experiments, no doubt important improvements in the methods of preparation now in use will occur to him.

**355. An Apology for the Use of very high Magnifying Powers.—**

Before describing the highest magnifying powers and the method of using them, it is unfortunately necessary for me to allude to objections which have been raised to their use and endeavour to answer some of them. Some persons still persist in asserting that no advantage is to be gained from powers above 300 diameters. Now, it would be impossible for me to answer all the objections that have been raised to this and other methods of observation, in Germany and elsewhere, and it is obvious that every observer has a perfect

right to work as he likes—to praise any processes of investigation which he believes to be advantageous and condemn those he considers objectionable. Unfortunately, however, some anatomists endeavour to disparage the means of research which they cannot or will not employ. There are observers who will not admit that the simplest and only efficient manner of introducing fluid into all parts of a tissue is to inject it by the vessels, and there are individuals who will maintain that those appearances can alone be trusted, and accepted, as natural appearances, which result from observations upon tissues immersed in water.

It is indeed most certainly true, that nothing is gained by subjecting specimens immersed in water to the highest powers. No wonder, therefore, that authorities who entertain this opinion should assert that high powers are useless. But it has been distinctly proved that water alters many tissues extremely, and completely destroys some of the most delicate textures. Its limpid character renders it impossible to fray out many delicate tissues immersed in it, or to subject them without complete destruction to the amount of pressure sufficient to make them thin enough for observation with high powers. Notwithstanding all this, not a few observers still use water and solutions of which water is the principal ingredient, and refuse to adopt or admit any principles opposed to this plan. Not content with working on in their own way, some of these observers do all they can to underrate the importance of observations made upon any other principles. If anyone makes out new points of structure by any new method, all that an authority who differs has to do in order to upset his views, is to state that *he* has not been able to see the structure described. If an *authority* simply denies the existence of what he has himself been unable to see, he is but too often implicitly believed, although he may not have taken the pains to try the only method of investigation by which the appearances in question could be seen. Some writers without having ever seen points of structure described by others, and without denying the truth of their observations, content themselves with intimating that the new notions are not likely to be true, because “such an arrangement does not exist in the corresponding tissue of a particular animal closely allied to the one in question,” which they have elaborately studied.

Only recently an article has appeared in a well-known journal, in which it is asserted, as an argument against the employment of high powers, that all the important discoveries in natural history and anatomy have been made with the aid of powers which do not magnify more than the quarter of an inch object-glass (200 diameters). It is only necessary to remark that the writer of this remarkable

paper must be quite ignorant of much of the microscopic work of the last five or six years. If he refers to the journals published in Germany, particularly to Schultz' Archiv, or to Kölliker's Zeitschrift, or to the Philosophical Transactions of the Royal Society, or the Microscopical Journal, he will soon be convinced he is mistaken. Vague and incorrect assertions of this kind too often find their way into journals in consequence of mere carelessness or indolence upon the part of the editors.

It is not, however, to be wondered at that the introduction of new and more refined methods of investigation should meet with considerable opposition, for in all departments of progressive knowledge are to be found men who seem to consider it their special duty to discover as soon as possible any symptoms of too rapid advance, and oppose them with the utmost vigour. It is to be regretted too that sometimes the innovators and rebels of one period become the obstructives of a later time. Some of the warmest advocates of progress seem to reach a period in their career when they tire of the constant change, and become unable to conquer their instinct to stand still. Regardless of the struggling crowds behind them, they long to rest in a position which they have at last acquired after years of intense labour; but they ought to remember that by so doing they are constituting themselves the strongest opponents of scientific progress and the enemies of true science, for science can never rest without the greatest danger of retrograding and losing much of what has been already gained. She must, therefore, have new and vigorous labourers always ready to take the places of any who show the slightest signs of fatigue or longing for ease.

There are, however, some branches of microscopical enquiry in which it is generally admitted that very high magnifying powers are absolutely necessary. For example, in such investigations as those which have lately been carried on by M. Pouchet and M. Pasteur, many of the more minute organisms can only be seen by a power magnifying upwards of 1,000 diameters. Bacteria, magnified 1,800 and 3,000 diameters respectively, are represented in pl. LVII, figs. 372 to 377. If still higher powers had been brought to bear upon the specimen, organisms still more minute than any represented in these figures would probably have been demonstrated.\* The most minute of such

\* My friend Dr. Child who has paid much attention to the subject referred to, makes the following remarks:—"The absolute necessity of using high magnifying power in attempting the solution of some of the problems which now present themselves to the physiologist is well shown in some of the recent investigations into the development of minute fungi. M. Pasteur has been in the habit of using an object-glass of 350 diameters, *see* his paper in the *Annales de Chimie*, vol. LXIV.



living organisms discoverable by a power of 10,000 linear, has been living and growing for some time before it attained sufficient dimensions and density to be visible to us. I believe if magnifying power could be efficiently increased to ten times ten thousand diameters, we should only be able to see particles of living matter increasing in size, and giving rise to new particles, which in their turn become detached—and so on. We should see nothing like the aggregation of particles, or the coalescence of already existing particles, of inanimate matter to form a mass of living matter. We should see, I believe, nothing but the increase in size and division of living particles already in existence. We might, however, be able to demonstrate germs of a degree of minuteness not yet thought of. But there is another matter of the greatest importance in the consideration of this subject, which has almost entirely escaped notice. Besides extreme minuteness in size, extreme tenuity or transparency may interfere with the detection of an object. Now, the greatest difference is observed in object-glasses in this particular. The best object-glasses will define clearly and accurately, bodies, which, from their transparency, are quite invisible under objectives only slightly inferior to the first. I feel quite sure that many statements recently made with reference to the mode of formation of the lowest forms of life, by the process of aggregation of particles, arise from imperfect means of observation, and that the real germs existed for a long time before they possessed sufficient density to be recognised by the object-glasses employed.

Objects which would be passed over by the observer and remain quite unnoticed when examined by ordinary powers at once attract attention if very highly magnified. If, therefore, high powers were of service only in bringing important but most delicate peculiarities of objects under observation—if by their use the attention were merely directed to minute points which would otherwise pass unob-

How entirely inadequate is such a power for the purpose of demonstrating the *absence* of these minute organisms from a sample of fluid, is shown by the fact that some of the bacterians figured in my paper in the Proceedings of the Royal Society, vol. XIV, p. 171, measure only about the  $\frac{1}{850000\pi}$  of an inch. An object of this size when examined with a power of 350 would appear to the eye little more than  $\frac{1}{300000\pi}$  of an inch in diameter, and it is evident that any number of such objects might be easily overlooked. In confirmation of this view I may cite the experience of Prof. Hallies of Jena, who, though he confirms in the main the results arrived at by M. Pasteur, yet in his recent work *Gährungs-Erscheinungen* (p. 50-51) insists strongly upon the necessity of using high powers in investigations of this nature. He has been in the habit of using powers of 1,000 and 1,500 diameters, and speaks of having met with organised bodies so minute as to appear as mere points even when so examined (p. 70)." This it will be observed is quite confirmatory of my own observations as stated in the text.—L. S. B.

served, it would be most desirable to employ them in carrying out advanced work.

The use of high powers in studying the peculiar structure of the wonderfully minute diatomaceæ is too obvious to require special notice here.

Everyone now aiming at original observation upon the minute structure of living beings, must become skilled in the use of far higher magnifying powers than those formerly considered necessary. But it must be remembered that in this department success depends entirely upon the method of preparation followed. The observer must always *begin* by using low powers, and as he improves in the *mode of making specimens*, he may advance to the use of the higher and the highest powers.

An entirely new field is now opening out for exploration, and a vast number of new anatomical facts will be discovered during the next few years, by the aid of new methods of investigation, and the use of high powers. Original research in this department of natural knowledge is at this time intensely interesting, for the points most open for enquiry involve questions of fundamental importance, which when determined, will give rise to great changes for the better in physiology. Minute anatomy has hitherto been far too little studied by medical practitioners. Is it not obvious that we ought to have a thorough knowledge of mere structure before we begin to discuss action? But is it not often the case both in physiology and medicine that mere speculations are received, and widely taught, which might be completely disproved by anatomical facts already demonstrated?

**356. Of the Highest Magnifying Powers.**—I include under this term all objectives above the eighth, or which magnify more than 400 diameters. In 1859, I was engaged in studying the arrangement of the nerves in voluntary muscle, and succeeded in preparing, by the process given in p. 298, some exceedingly thin sections, in which most delicate nerve fibres could be distinguished, but these were very pale and transparent, and the appearance was such as to lead me to the inference that in many cases apparently single fibres really consisted of several very fine fibres. I desired, therefore, to examine the specimens with a more powerful objective, and I begged Messrs. Powell and Lealand to endeavour to make for me a glass with a magnifying power double that of the sixteenth, which they succeeded in making in 1840. In the year 1860, I received from these makers the first twenty-sixth ever made. This lens magnified 1,800 diameters. I have now had great experience of its value, and can speak of it as a most excellent working glass. That it defines exceedingly well, and admits plenty of light, is obvious from the fact that it will allow

of the tube of the microscope being increased considerably in length. By a *working glass*, I mean one that can be employed without great trouble or difficulty, and does not require any elaborate arrangements with regard to illumination, adjustment, &c. In fact, it works fairly even without a condenser of any kind, the common concave mirror being alone used. There is plenty of room for focussing, although, of course, specially thin glass or mica must be employed. I have made and published many drawings of tissues of the higher animals magnified with this glass, and it need scarcely be said that, as it can be brought to bear upon textures of this class (even bone and teeth), thin sections of which are obtained only with great difficulty, it must be readily applicable to other departments of microscopical enquiry. Object-glasses of very high magnifying power have been more recently made by other makers. Hartnack's high power immersion objectives are among the best on the continent. An objective of high magnifying power (a twentieth) with a single front lens was made three or four years ago by Messrs. Smith and Beck. The magnifying power is about one third less than that of the twenty-fifth, and it appeared to me that the definition was not so good. The amount of light admitted was ample. It is, however, exceedingly difficult to express in words the merits of one glass as compared with another, and there can be no doubt that an observer who has used one glass very much, especially if he has made new observations by its aid, is almost of necessity prejudiced in its favour. I confess that, unless I had worked with an objective for a considerable period of time, I could not express a decided opinion as to its qualities. The difference between the working powers of the glasses of the best makers is, at most, very slight, and not to be demonstrated without the most exact and careful examination. At the same time, it is certain that the slightest advantage in defining power ought not to be underrated, for it may enable the observer to see some scarcely perceptible, but nevertheless most important, points not observed before, and in some instances the very slightest advantage of this kind may necessitate a complete alteration in general views up to that time received as true, and even considered to be fixed and unalterable. Improvement in the means of observation is of the utmost importance, and, however slight, is almost invariably soon followed by the discovery of new facts.

**357. "Immersion" Twenty-fifth.** — As already stated in p. 6, Hartnack, of Paris, has made some excellent lenses of high magnifying power upon the "immersion" principle. Messrs. Powell and Lealand have recently made a twenty-fifth object-glass upon the same plan. It possesses the following advantages :

1. A much thicker covering glass can be used than is possible with the ordinary  $\frac{1}{2}$ .

2. The specimen is much more highly illuminated, the same lamp, condenser, &c., being employed. The definition is, I think, slightly better, but the difference is not sufficiently decided to enable me to speak at all confidently upon this point.

**358. Of the One-fiftieth Objective.**—Since the last edition of this work was published, Messrs. Powell and Lealand have succeeded in making for me a *one-fiftieth of an inch objective* which magnifies very much more highly than the twenty-fifth. This wonderful glass was completed October 15th, 1864. It defines quite as well as the twenty-fifth, and there is no difficulty in obtaining plenty of light for the illumination of the objects (Proceedings of the Royal Society, January 19th, 1865). Some drawings by this objective are given in my Report on the Cattle Plague, and in pl. XXXVIII, fig. 244, and pl. XL, fig. 254, of this work. There is less difficulty in bringing this glass to a focus than would be supposed, although of course delicate manipulation and some degree of patience and care are requisite in working with it.

**359. The Apparent Size of an Object under different Powers.**—The following circles give an idea of the size which objects would appear in the microscope under the respective magnifying powers as stated:—

Molecule  $\frac{1}{20000}$  of an inch in diameter  
 $\times 250$  linear.



The same  $\times 700$ .



The same  $\times 1800$ .



The same  $\times 4000$ .



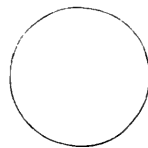
Molecule  $\frac{1}{20000}$  of an inch in diameter  
 $\times 250$  linear.



Molecule  $\frac{1}{4000}$  of an inch in diameter  
 $\times 700$ .



The same  $\times 1800$ .



The same  $\times 3000$ .

---

$\frac{1}{1000}$  of an English inch, magnified 250 linear.

---

$\frac{1}{1000}$  of an English inch, magnified 700 linear.

---

$\frac{1}{1000}$  of an English inch, magnified 2800 linear.

**360. Of the Covering Glass.**—The cover may be made of a very thin plate of mica, but glass possesses several advantages. Messrs. Chance, of Birmingham, have lately succeeded in manufacturing in quantity glass sufficiently thin for the  $\frac{1}{50}$ th. This is supplied by Messrs. Powell and Lealand. For mere examination of specimens, thin plates of mica answer well, and they may even be used for mounting the preparation; but as it is difficult to clean the surface without scratching it, it will be found better to use thin glass circles as the covers of specimens which are to be kept permanently.

An instrument for measuring the thickness of the thin glass kindly lent to me by Mr. Brooke, is represented in fig. 343, pl. LVI. The method of using it is too obvious to require explanation. The marks round the stem indicate tenths of a millimetre. The thickness of the ordinary thin glass is about 3 or 4 tenths of a millimetre, that for the  $\frac{1}{12}$ th objective under two tenths, and that suitable for the  $\frac{1}{50}$ th about  $\frac{1}{20}$ th of a millimetre, or less than  $\frac{1}{500}$  of an English inch.

**361. Illumination of Objects Magnified by very High Powers.**—

In using the sixteenth, twenty-fifth, and fiftieth, it is of the utmost importance that the illumination should be good. As already stated, the ordinary concave mirror gives light enough for the one twenty-fifth objective; but a light of greater intensity and far superior in quality may be obtained by other methods. After having tried a great many different plans, I have decided in favour of the illumination obtained from a round wicked paraffin lamp, pl. XI, figs. 47, 48, brought to a focus by a condenser. The ordinary condenser answers very well if to the front glass is fitted a cap made of very thin brass having a perfectly round central aperture less than the  $\frac{1}{30}$ th of an inch in diameter. Kelner's eye-piece, as before observed, p. 24, gives the brightest illumination, and if covered with a cap having an aperture of about  $\frac{1}{10}$  of an inch, the character of the light is all that can be desired. Sufficient light is afforded by this arrangement when the tube of the microscope is lengthened so as to give an amplifying power equal to 10,000 linear. The universal condenser referred to in p. 25, with a stop upon the surface of the front

lens as before mentioned gives an excellent quality of light, but less intense than Kelner's eye-piece.

In using these condensers, it is most important to employ the *direct light* from the lamp. The microscope and lamp are to be arranged as represented in pl. LVI, fig. 344. I cannot explain why the illumination should be so much better than when the mirror is employed, but I am sure that the quality of light produced is much more favourable for minute observation.

I have tried both the lime and magnesium lights, but they are not suitable for microscopical observation, the glare being too great, and the arrangements necessary inconvenient and troublesome, while paraffin, which can now be obtained everywhere without any difficulty, gives most satisfactory results at perhaps  $\frac{1}{30}$ th of the cost.

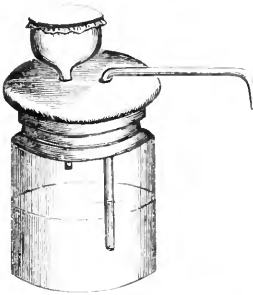
My friend, Mr. W. E. Kilburn has much increased the illuminating power of the paraffin lamp by causing a stream of oxygen gas to play around it. The gas is contained in a small bag which is placed under a weighted board. A piece of fine India-rubber tube connects the gas bag with a small pipe by which it is conducted just outside the wick of the lamp.

**362. Method of Increasing the Size of the Image without Altering the Object-Glass.**—Supposing the limits of magnifying power of the object-glass to have been reached, there are yet methods by which the dimensions of the image may be greatly increased. The eye-piece may be changed for a deeper one, or the distance between the object-glass and eye-piece may be increased. In practice, I have found that the latter plan is so much more advantageous that I now never use a deep eye-piece.

The  $\frac{1}{2}$  objective being applied,—when the tube is increased in length, so that from the lowest glass of the object-glass to the eye-glass of eye-piece, the distance measures 24 inches,—the magnifying power corresponds to upwards of 10,000 diameters: when the length is 20 inches—to about 6,000: 15 inches—to about 2,600: 11 inches to about 1,800. When the tube is thus increased in length, there is often some reflection from its interior which renders the image indistinct, an inconvenience which may be remedied either by increasing the diameter of the microscope tube to about  $2\frac{1}{2}$  inches, or by lining the ordinary tube with black velvet.

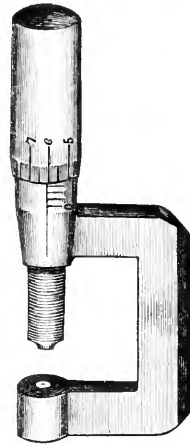
**363. Of Drawing Objects magnified with very High Powers.**—In delineating the appearances observed, I never represent a structure more highly magnified than is necessary to bring out the points, but I have found that as I improved my method of preparation, p. 290, I desired higher magnifying powers, and I am quite certain that great advantage will be reaped when powers far higher than

Fig. 342.



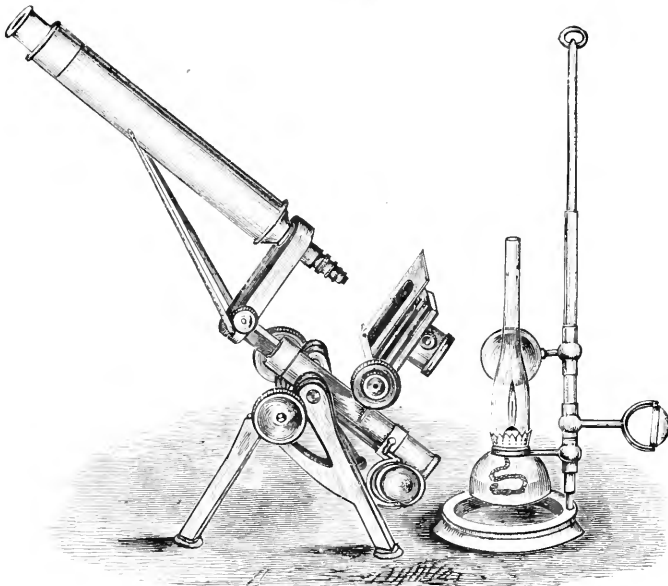
A glass bottle for containing xylene, benzene and acetic acid, required for mounting microscopical specimens. p. 301.

Fig. 343.



Instrument for measuring the thickness of the thin glass. p. 286.

Fig. 344.



Position of microscope and lamp for viewing objects with high powers. The light passes at once to the condenser instead of being reflected from the mirror. p. 288.

162 Method of Use

THE OBJECT GLASS

the  
ave  
now

Increased in  
to the eye-  
the magnifying  
when the length  
,600: 11 inches  
length, there is  
the image indis-  
her by increasing  
ches, or by lining

163 OF D

**y High Powers.**—  
r represent a struc-  
ring out the points,  
hod of preparation,  
I I am quite certain  
vers far higher than





200 diameters, will increase the image at this point to 215, and my  $\frac{1}{25}$ th, instead of magnifying about 1,600 diameters, increases the image of the object to 1,800 diameters. By increasing the length of the tube of the microscope between four and five inches, I obtain an amplification amounting to 3,000 diameters, and the  $\frac{1}{1000}$  of an inch becomes upwards of three inches in length, p. 287. The tube of the microscope bears increasing four or five inches in length even with the fiftieth, and in this way I have been able to see points in an object which I had failed to observe when using the twenty-fifth.

In plates LVII, LVIII, LXI, LXIII, some coloured figures are given. These have been produced by a double printing. Several different hues may be obtained without difficulty as in lithographic colour printing, but in printing large numbers, it need scarcely be said block printing is much cheaper than lithographic work.

NEW METHOD OF PREPARING SPECIMENS FOR RESEARCHES WITH  
THE AID OF THE HIGHEST MAGNIFYING POWERS YET MADE.

It has long been my opinion that real advance in our knowledge of minute structure depends mainly upon improvements in the methods of demonstration. Experiment has proved that the arrangement of the elements of the tissues of man and the higher animals in the recent state is not to be made out by examination in water, serum, vitreous humour, and other solutions usually employed for this purpose. In very many cases the refractive power of the tissue and other physical characters interfere with the clear demonstration of its structure. In the controversy concerning the arrangement of nerves in voluntary muscle, an independent reader would not fail to notice that different plans of demonstration had been employed.\* This, in some measure, explains the great discrepancy of the results arrived at. It is also to be noticed that those who deny the truth of facts stated by previous writers, have not in all cases adopted the method of investigation recommended by them.

In my first paper upon the distribution of nerves and muscle, I stated that the arrangement there described could not be seen unless a particular process of preparation was followed, yet my opponents have not adopted the plan pursued by me, nor even considered the principles upon which its success depends. Nay, although I strongly insisted upon the importance of injecting, partly for the purpose of ensuring the preservative fluid being distributed equally to all parts of the tissue, and partly to prevent the possibility of vessels being

\* See 'An Anatomical Controversy,' Archives of Medicine, vol. IV, p. 161.

mistaken for fine nerve fibres—the vessels have not been injected in specimens which have been supposed to controvert my conclusions. The mode of preparation I have advocated is not a mere hap-hazard plan, but is the result of information derived from numerous experimental observations made during the last fifteen years. Some have endeavoured to throw doubts upon my conclusions by describing how little they have themselves been able to see after the rough processes they have followed. The stout denial often given to the existence of a particular arrangement in too many instances, really means only that the individual who makes it has never seen the appearance. The only wonder is, that any one who has really earnestly studied, should be able to persuade himself that he has seen all that has been or all that can be seen.

I cannot venture to hope that many facts I have observed in the minute structure of the central and peripheral nervous system, will be confirmed until the process adopted by me is followed by others. It is true that my specimens can be shown to others; but it so happens that working men have but few opportunities of examining each other's specimens, and when an opportunity does occur, it not unfrequently happens that time is not allowed to investigate the specimens fairly. The consequence of this is, that working in circles goes on to a terrible extent. Great labour is utterly wasted, and there is but very slow progress compared with that which would attend our efforts if observers generally were agreed upon the principles upon which minute anatomical observations should be conducted. Doubtless, every observer soon finds out valuable methods of detail for himself which satisfy him,—but as he will not be able in many cases to communicate to others the practical details upon which his success depends, it is often exceedingly difficult to ascertain the real merits of any given process. Nevertheless, it is a question capable of being settled most positively, whether nerves can be followed in tissues which are impregnated with syrup, glycerine, or some such medium, for a greater distance than when the same textures are immersed in water, serum, vitreous, &c., and whether or not more fibres and finer fibres can be seen in the former than in the latter case. A simple experiment will convince any one that this is so, and if observers would prepare small portions of the same tissue in these two different media, and compare the results, they would, I am sure, soon agree upon one principle of great importance in investigation. It is mainly with the view of encouraging free discussion upon this most important question, and in the hope that ere long some general process of investigation may be followed, that I publish my own conclusions and describe somewhat minutely the process which I now

follow. I do not for one moment pretend that it is equally applicable to all tissues, or that it will succeed in all hands; but I am confident that it is based upon principles of the utmost importance for successful demonstration. Every year I myself discover improvements in detail of the utmost advantage; but the basis of the process remains the same, and, as I have now been actively engaged in minute microscopical investigation for twenty years, it is scarcely possible that principles which have been adhered to so long, can be destitute of advantages. Moreover, in the hands of some of my pupils it has answered as well as in my own.\*

**364. Conditions to be fulfilled in Demonstrating Minute Structure by the Highest Powers:—**

1. Of many tissues, sections sufficiently thin for high powers cannot be obtained by the processes usually adopted. In order to make the specimen thin enough, pressure must be employed, and in many instances very strong pressure is required. Even by very moderate pressure, tissues immersed in water are destroyed completely, and experience has proved that the requisite amount of pressure can only be employed if the tissue be immersed in, and thoroughly impregnated with, a *viscid medium*, which is not only readily miscible with water in all proportions, but with such chemical reagents as may be required to act upon one or more constituents of the tissue for the purposes of demonstration.

2. As many structures are exceedingly delicate, and undergo change very soon after death, it is necessary that the medium in which they are examined should have the property of preventing softening and disintegration, and should act the part of a preservative fluid.

3. In order that tissues should be uniformly permeated with a fluid within a very short time after the death of the animal, it is necessary that the fluid should come quickly in contact with every part of the texture. This may be effected in two ways:—

- a.* By soaking very thin pieces in the fluid, or
- b.* By injecting the fluid into the vessels of the animal.

4. As different structures require fluids of different refractive power for their demonstration, the medium employed must be such that its refractive power can be increased or diminished, unless for

\* An excellent illustration of the great importance of careful preparation is afforded by the reply of Mr. Gedge, of Cambridge, to the observations of Dr. Moxon, concerning the distribution of nerve fibres to the muscles of a culex larva.—*Microscopical Journal*, July 1867, p. 193.

the medium fulfilling the former condition, another can be readily substituted which fulfils the latter requirements.

5. In investigations upon the changes which structure undergoes in the organism, it is necessary to distinguish between that part of the texture which is the oldest, and that which has just been produced—between matter in which active changes are going on, and matter which is in a passive state. It is only by fulfilling this requirement that the direction in which growth takes place, and the point where new matter is added, can be ascertained.

6. It is most important in many investigations, that we should be able to distinguish positively the vessels from the other constituents of the tissue, and it is necessary that the process by which this is effected should not interfere with the demonstration of all the tissues in the immediate vicinity of the vessels.

7. It is of the utmost importance, that the medium employed for demonstration should have the property of preserving the specimens, so that observers should be able to exhibit their preparations to others.

Glycerine and syrup fulfil the requirements mentioned in the foregoing paragraphs.

**365. Action of Glycerine and Syrup on Tissues.**—Strong syrup may be made by dissolving with the aid of heat, lump sugar in distilled water, in the proportion of about three pounds to a pint.

Glycerine may be used diluted or undiluted. It is necessary in many cases to employ the strongest glycerine. In this country we have had the advantage of the beautiful preparation called Price's glycerine, which is made of specific gravity 1.240. It has been said that glycerine and strong syrup are not adapted for preserving soft tissues, because the tissues shrink, and soft cells collapse in consequence of exosmose of their fluid contents. But I have many hundred specimens preserved in the strongest glycerine I could procure, and I should be glad if glycerine could be made of still greater density. There would be no difficulty in impregnating even very soft tissues with it. In fact, the objections urged are theoretical, and result from ignorance of some properties of the tissues on the part of those who have advanced them. If objectors had simply tried the experiment, they would have found no difficulty whatever in carrying out the process. Tissues possess a considerable elastic property, and although they shrink when immersed in a medium of considerable density, they gradually regain their original volume if *left in it for some time*. In practice, the specimen is first immersed in *weak* glycerine or syrup, and the density of the fluid is gradually increased. In this way, in the course of two or three days, the

softest and most delicate tissues may be made to swell out almost to their original volume in the densest glycerine or syrup. They become more transparent, but no chemical alteration is produced, and the addition of water will at any time cause the specimen to assume its ordinary characters.

The hardest textures, like bone and teeth, may be thoroughly impregnated and preserved in strong glycerine, p. 305. Cerebral tissues, delicate nervous textures like the retina, or the nerve textures of the internal ear, may be permeated by the strongest glycerine, and when fully saturated with it, dissection may be carried to a degree of minuteness which I have found impossible in any other medium. Nor is the use of glycerine and syrup confined to the tissues of man and the higher animals. I have preparations from creatures of every class. The smallest animalcules, tissues of entozoa, polyps, star fishes, mollusks, insects, crustacea, infusoria, various vegetable tissues, microscopic fungi and algæ of the most minute and delicate structure, as well as the most delicate parts of higher vegetable tissues, may all be preserved in these viscid media; so also may be preserved the slowest and most rapidly growing, the hardest and softest morbid growths, as well as embryonic structures at every period of development, even when in the softest state. I am, indeed, not acquainted with any animal or vegetable tissues which cannot with the greatest advantage be mounted thus. All that is required is, that the *strength of the fluid should be increased very gradually until the whole tissue is thoroughly penetrated by the strongest that can be obtained*. In many cases the tissues may be more effectually saturated with the glycerine by injection than by soaking, p. 298. Glycerine has long been in use among microscopists, but my object is to show that it is universally applicable, that it or syrup may be made the basis of all solutions employed by the microscopical observer with the greatest advantage, that many points are to be demonstrated by the aid of these solutions, which have hitherto escaped observation, and that there are reasons for believing that very much may yet be discovered by the use of these substances.

**366. Of the Advantages of Viscid Media for the Dissection of Tissues for Examination with the Highest Powers.**—Minute dissection can be carried on in these viscid media with greater facility and certainty than in more limpid fluids. I can readily detach the most minute parts of tissues, separate the different structures in one texture, without tearing or destroying them, unravel convoluted tubes, and perform with ease a great variety of minute operations, which it would be impossible to effect by any of the ordinary methods of dissection. With care in regulating the temperature, I can soften tex-

tures thus preserved in syrup to the precise extent required for further minute dissection, and even very hard textures may thus be softened, so that by gradually increased pressure and careful manipulation, exceedingly thin layers can be obtained without the relation of the anatomical elements to each other being much altered, and without any of the tissues being destroyed.

**367. The Carmine Fluid for Staining Germinal Matter.**—The composition of this fluid has been already given in p. 109, where also will be found the directions for making it. This fluid will be required to be made stronger or weaker in particular cases and great advantage sometimes results from diluting it with alcohol. The quantity to be added to obtain the best results can be ascertained by trying a few experiments.

The length of time required for staining the tissue successfully varies much. Some tissues are coloured very slowly. Fibrous tissue, bone and cartilage, even in very thin sections, will require twelve hours or even more, but perfectly fresh soft embryonic tissues, and very thin sections of the liver and kidney, thin sections of morbid growths rich in cells, may be coloured in half an hour, while the individual cells of the above structures, placed on a glass slide, may be coloured in less than a minute. I have often coloured the germinal matter of the fresh liver cell *in a few seconds*, by simply allowing the carmine fluid to flow once over the specimen.

**368. Glycerine and Syrup.**

1. *Weak common glycerine* of about the specific gravity 1050.
2. *The strongest Price's glycerine* that can be obtained.
3. *Syrup* made by dissolving, by the application of a gentle heat in a water bath, 3 lbs. of sugar in a pint of distilled water. A weaker solution can be prepared, as required, by mixing equal parts of syrup and water.

Although I have found syrup of great value in many special enquiries, I cannot recommend it for general use, in consequence of its liability to be invaded by numerous fungi, which often destroy the specimen.

**369. The Injecting Fluid.**—For injecting the finest capillaries in specimens which are to be mounted for the highest powers, I have found a slight modification of the original Prussian blue fluid, the composition of which is given in p. 93, fulfil all the requirements. The following mixture has succeeded admirably in my hands, and I therefore recommend it strongly. It penetrates to the finest vessels, and may even be forced into developing capillaries which are only in part pervious. It never forms a deposit. The specimens injected

with it retain their colour perfectly, and the injected tissues can also be stained with carmine.

Price's glycerine, 2 oz. by measure.

Tincture or solution of perchloride of iron,\* 10 drops.

Ferrocyanide of potassium, 3 grains.

Strong hydrochloric acid, 3 drops.

Water, 1 oz.

Mix the tincture of iron with one ounce of the glycerine ; and the ferrocyanide of potassium, first dissolved in a little water, with the other ounce. These solutions are to be mixed together very gradually in a bottle, and are to be well shaken during admixture. *The iron solution must be added to the ferrocyanide of potassium.* Lastly, the water and hydrochloric acid are to be added. Sometimes I add a little alcohol (2 drachms) to the above mixture.

This fluid (it is not a *solution*), does not deposit the slightest sediment, even if kept for some time, and it appears like a blue solution when examined under high magnifying powers, in consequence of the insoluble particles of Prussian blue being so very minute.

If preferred, the Turnbull's blue may be used instead of Prussian blue, half the quantities of the ferridcyanide of potassium and sulphate of iron recommended in p. 94, being used, and the hydrochloric acid may be left out. The glycerine and water in the proportions just given.

**370. Other Colouring Solutions with Glycerine.**—Many of the staining fluids given in pp. 110 to 113 may be prepared with glycerine. Thus, I dissolve nitrate of silver, the anilin colours, and many others, in glycerine instead of in water. The salt should be dissolved in a very little water in the first instance, and this solution added to the glycerine. Indeed, all the fluids I now use for preparing specimens contain syrup or glycerine as the basis.

**371. Glycerine and Water and Glycerine and Acetic Acid for Washing and Preserving thin Sections.**—After the specimen has been properly stained, small pieces are to be washed in a solution consisting of—

Strong glycerine, 2 parts.

Water, 1 part.

After being soaked in this for an hour or two, they may be transferred to the following acid fluid :—

Strong glycerine, 1 ounce.

Strong acetic acid, 5 drops.

\* The *Tinctura Ferri Perchloridi* and the *Liquor Ferri Perchloridi* of the British Pharmacopœia of 1867, are of the same strength, and consist of one part of strong *Liquor Ferri Perchlor* to three parts by measure of spirit or water.



After the pieces of tissue have remained in this acid fluid for three or four days, it will be found that they have regained the volume they occupied when fresh. Even very soft and pulpy tissues will gradually swell out and regain their original volume in the strongest glycerine.

*On Chemical Reagents Dissolved in Glycerine.*

It being established as a principle that, for minute investigation, tissues must be immersed and thoroughly saturated with viscid media miscible in all proportions with water, it almost follows that reagents applied to such tissues should be dissolved in media of the same physical properties. For a long time past I have been in the habit of employing solution of potash, acetic acid, and other reagents, dissolved in glycerine instead of in water. Thus a complete chemical examination may be conducted upon tissues, solutions, or deposits preserved in viscid media. The reactions are most conclusive, but of course take a much longer time for completion than when carried out in the ordinary manner. Ten or twelve hours must be allowed to elapse before the change is complete, and the process is expedited if the slide be placed in a warm place (about  $100^{\circ}$ ).

**372. Acetic Acid Syrup.**—In some cases I have found the addition of very strong solutions of certain reagents necessary. For example, the greatest advantage sometimes results from the application to a tissue of very strong acetic acid. If the acid be added to glycerine in quantity, the solution will no longer be viscid, so that another plan must be resorted to. I thicken the strongest acetic acid with sugar, a gentle heat being applied to dissolve the sugar. Thus a very strong acetic acid solution of the consistence of syrup can be most readily prepared. Fungi do not grow in this solution. Specimens impregnated with syrup may be transferred to glycerine, but they must be soaked in different portions of weak glycerine for some time in order to dissolve out the sugar thoroughly before they are transferred to strong glycerine, otherwise crystallisation of the sugar will probably occur, and the preparation will be destroyed.

**373. Solutions of Potash and Soda.**—Strong solutions of potash, soda, and other reagents, may be added to the strongest glycerine.

**374. Solutions of Chromic Acid and Bichromate of Potash.**—A most valuable mixture of this kind to the microscopist, is a solution of chromic acid in glycerine, and another solution of bichromate of potash in the same fluid. A few drops of a strong solution of chromic acid may be added, so as to give to the glycerine a pale straw colour. The bichromate of potash solution is prepared by adding from ten to

twenty drops of a strong saturated solution of bichromate of potash to an ounce of the strong glycerine. By this plan, the hardening effects of these reagents upon the finest nerve tissues are improved, while the granular appearance which is caused by aqueous solutions of these substances is much less. Sometimes advantage seems to result from mixing a little of the chromic acid with the acetic acid solution of glycerine.

If desired, sugar may be substituted for glycerine in all the fluids employed, including the carmine and injecting fluids ; but glycerine, although more expensive, possesses many advantages, and, as far as I am able to judge, is the best viscid medium to employ for general purposes.

One great inconvenience of syrup arises from the growth of fungi, especially in warm weather. Camphor, creosote, carbolic acid, naphtha, prevent this to some extent ; but it is a disadvantage from which strong glycerine is perfectly free. Sometimes, too, crystallisation occurs, and destroys the specimen. In using first a syrupy fluid, and then glycerine, to the same specimen, it must be remembered that the two fluids mix but slowly, so that plenty of time must be allowed for the thorough penetration of the medium used last.

I keep various tests, such as alcohol, ether, the various acids and alkalies, and other tests in the form of viscid solutions made with glycerine or sugar. The reaction of the iodine tests for amyloid matter, starch and cellulose, is much more distinct when employed in this way. The plan is, to allow the texture to be tested to be thoroughly saturated with the strong glycerine solutions, and then to add water. In the course of a few hours the reaction takes place very strongly.

**375. Of the Injection of Solutions of various Chemical Compounds dissolved in Glycerine.**—When it is desired to subject the tissues of an organ or of the body generally to the influence of certain chemical solutions, these may be injected and oftentimes the most perfect results are obtained by this process. However carefully small pieces of tissues may be soaked in fluids the action is irregular, and while the process has gone too far upon the surface, the interior often escapes entirely. But by injection, every part of the tissue is acted upon and almost precisely in the same degree. Many beautiful results are to be obtained by carrying out this plan, and the skilled observer will be able to suggest to himself many experiments likely to lead to most valuable conclusions, particularly in connection with the subject of development. The calcareous matter of bone and other tissues may be dissolved out in this way by very slow degrees without disturbing in the least the arrangement

of the most delicate tissues, or interfering with the demonstration of their ultimate structure.

*The Preparation of Specimens.*

**376. The Practical Operation of Preparing Tissues for Examination with the Highest Powers.**—The general plan I follow, is the same for all tissues of all vertebrate animals and morbid growths; but I will describe the several steps of the process as they are conducted in the demonstration of the structure of the ganglion cells, described in my paper in the *Phil. Trans.* for 1863, and of the papillæ of the frog's tongue, described in the communication presented to the Royal Society in June, 1864. The figures in plates XLIII, LXVII, and XLVIII, have been taken from these memoirs.

The description given also applies to the mode of preparing specimens of muscular fibre to demonstrate the mode of distribution of the finest branches of nerve fibre.\* *See* plates XXVIII, LIX, LX, LXI, and LXII. It is the same plan which I have followed in the investigation of the minute structure of the brain, spinal cord, and ganglia of man and the higher animals.†

My researches upon the tissues of the frog have been principally conducted upon the little green tree frog (*Hyla arborea*), for experience has proved to me that the tissues of this little animal are so much more favourable for investigation than those of the common frog, that it is well worth while to obtain specimens, even at the cost of 2s. or 2s. 6d. each.

The frog is killed by being dashed suddenly upon the floor, but it must first be carefully folded up in the centre of a large cloth, so that the tissues may not be bruised in the least degree. Next, an opening is made in the sternum, the heart exposed, and a fine injecting pipe, after being filled with a little injection, is tied in

\* 'On the distribution of nerves to the elementary fibres of striped muscle.' *Phil. Trans.*, 1860.

'Further observations.' *Phil. Trans.*, 1862.

'Further observations in favour of the view that nerve fibres never end in voluntary muscles.' *Proceedings of the Royal Society*, June 5th, 1863.

'On the structure of the sarcolemma of the muscular fibres of insects, and of the exact relation of the nerves and tracheæ to the contractile tissue of muscle.' *Microscopical Society*, June, 1864.

† 'On the minute structure of the grey matter of the convolutions of the brain.' *Proceedings of the Royal Society*, vol. XII, 671, 1863.

'Indications of the paths taken by the nerve currents as they traverse the caudate nerve cells of the spinal cord and encephalon.' *Proceedings of the Royal Society*, July, 1864.

the artery. This part of the operation is conducted as fully described in page 98, except that the Prussian blue fluid given in p. 296, is used instead of the more inexpensive fluid made with common glycerine. The injection ought to be complete in from twenty minutes to half an hour, and sometimes in less time than this. The injection being pale, cannot be very distinctly seen by the unaided eye, but if the operation has been conducted successfully, the tissues will be found swollen and the areolar tissue about the neck will be fully distended. The observer must not, however, attempt to inject a *Hyla* before he has succeeded in injecting the common frog perfectly, for the *Hyla*, being smaller, is somewhat more difficult to inject than the common frog or the newt.

The injection being complete, the abdominal cavity of the frog is opened, and the viscera washed with strong glycerine. The legs may be removed, the mouth slit open upon one side, and the pharynx well washed with glycerine. If it is desired to prepare one organ only, this may, of course, be removed and operated upon separately; but I generally subject the entire trunk, with all the viscera, to the action of the carmine fluid. If the brain and spinal cord are special objects of enquiry, the cranium and the spinal canal must be opened so as to expose the organs completely, before the staining process is commenced. It is, however, better to adopt the process described in p. 304, and in investigations upon the brain and cord.

Enough of the carmine solution is next placed in a little porcelain basin or gallypot, to cover the entire trunk and viscera. The specimen is then moved about in the carmine fluid, so that every part that is exposed is thoroughly wetted by it; sometimes slight pressure with the finger facilitates the imbibing process. It is left in the carmine fluid for a period varying from four to six or eight hours, being occasionally pressed and moved about during this time, so as to ensure the carmine fluid coming into contact with every part. By this time the blue colour of the vessels of the lungs, viscera, &c., will have entirely disappeared, and all the tissues will appear uniformly red. The staining is now complete. The carmine fluid is poured off and thrown away, and the preparation washed quickly with the glycerine solution, p. 296. This fluid may be preserved in a wash bottle, made according to the plan figured in pl. XXII, fig. 143, but smaller than this,—and projected upon every part so as to wash away the superfluous carmine fluid, pl. LVI, fig. 342. The specimen is now placed in another little basin and some strong glycerine poured over it; it is then left for two or three hours, and a little more strong glycerine added; when, from six to twelve hours since the specimen

was removed from the carmine solution have elapsed, the preparation is ready for the last preliminary operation. The glycerine used for washing it is poured off, and sufficient strong Price's glycerine added just to cover it. To this, three or four drops of strong acetic acid are added, and well mixed with the glycerine. In this acid fluid the preparation may be left for several days, when a small piece of some vascular part may be cut off, placed in a drop of glycerine, and subjected to microscopical examination. If the injected vessels are of a bright blue colour, and the nuclei of the tissues of a bright red, the specimen is ready for minute examination; but if the blue colour is not distinct, three or four more drops of acetic acid must be added to the glycerine, and the preparation soaked for a few days longer.

If the nuclei are of a very dark red colour, and appear smooth and homogeneous, more especially if the tissue intervening between them is coloured red, the specimen has been soaked too long in the carmine fluid; but in this case, although parts upon the surface may be useless for further investigation, the tissues below may have received the proper amount of colour.

The tissues or organs to be subjected to special investigation may now be removed, and transferred to fresh glycerine; they may be kept in little corked glass tubes, pl. XXII, fig. 144, and properly labelled. Generally, the tissue will contain sufficient acetic acid, but if this is not the case, one drop more may be added.

Suppose, now, the nerves with the small vessels and areolar tissue at the posterior and lower part of the abdominal cavity have been placed in one tube, and the prepared tongue of the *Hyla* in another, the former specimen may be taken out of the glycerine and spread out upon a glass slide. If the specimen be examined with an inch power, numerous microscopic ganglia may be seen, pl. LXVIII, fig. 412. Several of these perhaps are close to small arteries. Those which are most free from pigment cells are selected, and removed carefully by the aid of a sharp knife, fine scissors, forceps, and a needle point. This operation may be effected while the slide is placed upon the stage of the microscope. The *transmitted light* enables the observer to see the minute pieces very distinctly with the unaided eye, if necessary a watchmaker's lens or a three-inch power may be used. The pieces selected are transferred to a few drops of the strongest glycerine placed in a watch glass or in one of the little china colour moulds, § 85, p. 47, and left to soak for several hours.

The microscopical examination of the specimen may now be carried out. One of the small pieces is placed upon a glass slide, in a drop of fresh glycerine, and covered with thin glass. The glass

slide may be gently warmed over the lamp, and the thin glass pressed down upon the preparation by slight taps with a needle point. The specimen may now be examined with a quarter, and afterwards with the twelfth of an inch object-glass. A good deal of granular matter will possibly obscure the delicate points in the structure. The slide is again gently warmed, and, with the aid of a needle, the thin glass is made to slide over the surface of the specimen, without the position of the latter being altered, and then removed and cleaned. The specimen is then washed by the addition of drop after drop of strong glycerine containing five drops of acetic acid to the ounce. The slide can be slightly inclined while it is warmed gently over the lamp, in such a manner that the drops of glycerine slowly pass over the specimen and wash away the débris from its surface.

I find it better to place delicate specimens upon a circle of thin glass about  $\frac{3}{4}$  of an inch in diameter, instead of upon a glass slide. The circle is then placed in a wooden slide in the centre of which a hole has been drilled of the proper dimensions to receive it. A ring of gummed paper is placed at the back of the slide and to this the round glass is fixed when the specimen has been covered with the smaller circle of thin glass, and this has been properly fixed in its place by cement.

*Dropping Bottles.*—The most convenient instrument for dropping the glycerine on the specimen is a little bottle, of two ounces capacity, with a syphon tube drawn to a point, and a straight tube, with an expanded upper part, over which is tied a piece of stout sheet vulcanised India-rubber. Pl. LVI, fig. 342. Upon compressing the air, by pressing down the India-rubber, the glycerine is forced drop by drop through the syphon tube and allowed to fall upon the specimen. These little bottles can be obtained of Mr. Matthews, Mr. Highley, and Mr. Collins.

When several drops of pure glycerine have been allowed to flow over the specimen, the thin glass cover, after having been cleaned, is re-applied and pressed upon the specimen very gradually, but more firmly than before. Any excess of glycerine is easily removed by placing small pieces of clean blotting paper at the side of the thin glass. If the preparation looks pretty clear when examined with the twelfth, the glass cover may be cemented down with Bell's cement, p. 48, and the specimen left for many days in a quiet place. It may then be re-examined, the process of washing with glycerine repeated, and further pressure applied until it is rendered as thin as is desired. When this point has been reached, more glycerine with acetic acid is to be added, and a plate of mica or the *thinnest glass cover*, p. 287, applied, when it may be examined with the twenty-

fifth. The process of flattening may be pushed still further if desirable,—and if only carried out very slowly by gentle taps or careful pressure with the finger and thumb, *from day to day*, the elements of the tissues are gradually separated without being destroyed. If there be much connective tissue, which interferes with a clear view of the finest nerve or muscular fibres, it may be necessary to immerse the specimen for some days in the acetic acid syrup, and then transfer it to fresh glycerine.

The success of this process depends upon the care and patience with which it is carried out. The most perfect results are obtained in cases where the washing, pressure, and warming have been very slowly conducted, and it is most interesting to notice the minute points of structure which are gradually developed and rendered clearer by the repeated application of a gentle heat, subjecting the specimen to a little firmer pressure or by further soaking in a little fresh glycerine placed in a watch-glass.

Specimens of tissue prepared in this way can be transferred from slide to slide, and no matter how thin they may be, after having been allowed to soak in fresh glycerine they may always be laid out again perfectly flat by the aid of needles upon another slide. The action of these viscid fluids is most valuable, and I feel sure that by the process here given,—the principle being retained but the details modified in special cases, many new and important anatomical facts will be discovered.

The process of preparing the papillæ of the frog's tongue is precisely the same. Small pieces of the mucous membrane being removed by sharp scissors, they are transferred to glycerine, subjected to the same very gradually increased pressure, until the individual papillæ are themselves slightly flattened. It is possible from a specimen to remove a number of the separate papillæ on a needle point, transfer them to glycerine or to the acetic acid syrup, and then mount them for examination with the  $\frac{1}{50}$ th object-glass. All the points I have described and figured in my paper (Royal Society, 1864) may then be demonstrated in several papillæ, pl. LXIII, fig. 389.

Thin sections of brain, spinal cord, &c., may be subjected to the same process for examination with the highest powers. The specimens illustrating my paper on 'Indications of the paths taken by the nerve currents as they traverse the caudate nerve cells of the spinal cord and encephalon,' published in the Proceedings of the Royal Society, July, 1864, were prepared in the manner already described, but they were soaked for some months in a weak glycerine solution of acetic acid. The most delicate preparations retain their characters for many months, and some for several years, so that in

many cases the very preparations from which my drawings have been made, have been preserved, and may now be compared with them.

**377. Modification of the above Plan.**—Acting upon the principles above referred to, I have more recently modified the foregoing process by injecting the alkaline carmine fluid into the vessels in the first instance for the purpose of staining the germinal matter of the tissues, and afterwards, when the colouring was complete, the acid Prussian blue fluid.

The carmine fluid employed should be stronger than that already recommended, p. 109, and it is better to add a little more alcohol. The following succeeds well for the frog and newt.

Carmine, 15 grains.  
Strong liquor ammonia,  $\frac{1}{2}$  drachm.  
Price's glycerine, 2 ounces.  
Alcohol, 6 drachms.

This fluid is to be injected carefully with very slight pressure, bearing in mind that the alkaline ammonia is very apt to soften the delicate vascular walls. When the vessels are fully distended, the preparation is to be left for from twelve to twenty-four hours, in order that time may be allowed for the carmine fluid which has permeated the capillaries in all parts of the body to soak through the different tissues and stain the germinal matter fully. Next a little pure glycerine is to be injected, in order to cause any carmine fluid still remaining in the vessels to pass through, or to dilute it so much that carmine will not be precipitated in quantity by the acid fluid now to be introduced.

The fine Prussian blue injecting fluid, the composition of which is given on p. 296, is now to be injected with the utmost care, for the vessels, particularly of young animals, having been somewhat softened by the ammonia are very liable to give way if much pressure be applied. When the vessels are fully distended with the Prussian blue fluid, the injected preparation is to be divided into small pieces, and these are to be soaked in glycerine and acetic acid, as has been already recommended in p. 296.

Very beautiful specimens from every tissue in the body of a small animal (frog, newt, mouse, bat, small bird, &c.), may be prepared in this way; but as the operation of injecting has to be performed twice there is greater risk of rupturing the vessels. The student should therefore be an experienced injector before he attempts to carry out this process, or he will meet with disappointment, and waste his injecting fluids.



**378. Of the Preparation of Hard Tissues for Examination with the Highest Powers, Bone, Teeth, &c.**—The methods generally employed, p. 82, for demonstrating the structure of bone, teeth, and other hard tissues, only enable us to form a notion of the dead and dried texture. The soft material is dried up before the section is made.

And yet this very soft material, which is not represented in the drawings published in many works, is that which makes the difference between the dead bone or tooth, and that which still remains an integral part of the living body. So far from this soft matter being unimportant, it is the most important of all the structures of the hard texture. It is by this alone that all osseous and dental tissues are formed and nourished. From the arrangement of this soft matter not having been generally recognised, the most erroneous ideas have prevailed, and still prevail, upon the formation and nutrition of these hard tissues.

Even now it is generally believed that the dentinal tubes are real tubular passages for conveying *fluids* to all parts of the dentine, and are thus subservient to its “nutrition,” and yet it is more than eight years since Mr. Tomes proved most conclusively that these so-called “tubes” were occupied in the recent state by a moist but tolerably firm material (Phil. Trans., February, 1856). I have verified Mr. Tomes’ description, and am quite certain that the so-called dentinal tubes are not channels for the mere flowing up and down of nutrient fluid.\*

Suppose a tooth is to be prepared for minute microscopical investigation, we may proceed as follows. The same plan is applicable to bone and shell.

1. As soon as possible after extraction, the tooth may be broken by a hammer into fragments, so as to expose clean surfaces of the tissues. Pieces of dentine with portions of pulp still adhering to them may then be selected and immersed in the carmine fluid, and placed in a vessel lightly covered with paper, so as to exclude the dust. The whole may be left in a warm room for from twenty-four to forty-eight hours.

2. The carmine solution may then be poured off, and a little plain dilute glycerine added, p. 296.

3. After the fragments of teeth have remained in this fluid for six or eight hours, the excess, now coloured with the carmine, may be poured off, and replaced by a little strong glycerine and acetic acid, p. 296.

\* On the structure of recent bone and teeth, see my lectures on “*The Structure and Growth of the Tissues*,” Royal College of Physicians, 1860.

4. After having remained in this fluid for three or four days, it will be found that the portions of soft pulp have regained the volume they occupied when fresh. They have swollen out again even in the strongest glycerine.

5. I have found that in many cases, when it is desired to study the arrangement of the nerves, it is necessary to harden the pulp by immersion in a glycerine solution, made by adding to an ounce of the glycerine solution of the acetic acid, two or three drops of a strong solution of chromic acid, p. 297. The fragments may remain in this solution for three or four days, and then be transferred to the acetic acid solution, in which they may be preserved for years with all the soft parts perfect.

6. The specimens are now ready for examination. Thin sections are *cut* with a knife from the fractured surfaces of the dentine, including a portion of the soft pulp. The knife should be strong, but sharp. In practice I have found the double-edged scalpels made for me by Messrs. Weiss and Son, of the Strand, answer exceedingly well for this purpose, nor will the edge of the knife be destroyed so soon as would be supposed.

7. The minute fragments of sections thus obtained are placed upon a slide and immersed in a drop of pure strong glycerine, in which they may be allowed to soak for an hour or more, and then examined by a low power (an inch). The best pieces are to be selected by the aid of a fine needle, and removed to a drop of glycerine containing two drops of acetic acid to the ounce, and placed upon a clean slide. The thin glass cover is then carefully applied, and the specimen may be examined with higher powers.

8. If it is desired to retain the specimen, the excess of glycerine fluid is absorbed by small pieces of blotting-paper, and the glass cover cemented to the slide by carefully painting a narrow ring of Bell's microscope cement round it. When this first thin layer is dry, the brush may be carried round a second time, and after the lapse of a few days, more may be applied. Mounted in this way the specimen will retain its character for years.

Hard tissues, like bone, dentine, and enamel, become somewhat softened by prolonged maceration in glycerine, and if a few drops of acetic acid are added, the softening process may be carried still further, and yet without the calcareous matter being dissolved out to any perceptible extent. If desired, of course the calcareous matter may be in part or entirely removed by increasing the strength of the acid fluid in which the preparation is immersed. But, far short of this, the hard, brittle texture is so altered, that thin sections may be *cut* without any difficulty. Specimens prepared in this way

OSARIAN OVA.—STICHLERBACH.

FIGURE 1. 2. 3. 4. 5. 6. 7. 8. 9. 10. 11. 12. 13. 14. 15. 16. 17. 18. 19. 20. 21. 22. 23. 24. 25. 26. 27. 28. 29. 30. 31. 32. 33. 34. 35. 36. 37. 38. 39. 40. 41. 42. 43. 44. 45. 46. 47. 48. 49. 50. 51. 52. 53. 54. 55. 56. 57. 58. 59. 60. 61. 62. 63. 64. 65. 66. 67. 68. 69. 70. 71. 72. 73. 74. 75. 76. 77. 78. 79. 80. 81. 82. 83. 84. 85. 86. 87. 88. 89. 90. 91. 92. 93. 94. 95. 96. 97. 98. 99. 100.

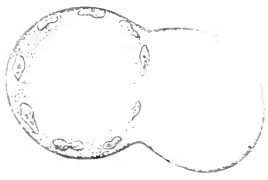


FIGURE 1. 2. 3. 4. 5. 6. 7. 8. 9. 10. 11. 12. 13. 14. 15. 16. 17. 18. 19. 20. 21. 22. 23. 24. 25. 26. 27. 28. 29. 30. 31. 32. 33. 34. 35. 36. 37. 38. 39. 40. 41. 42. 43. 44. 45. 46. 47. 48. 49. 50. 51. 52. 53. 54. 55. 56. 57. 58. 59. 60. 61. 62. 63. 64. 65. 66. 67. 68. 69. 70. 71. 72. 73. 74. 75. 76. 77. 78. 79. 80. 81. 82. 83. 84. 85. 86. 87. 88. 89. 90. 91. 92. 93. 94. 95. 96. 97. 98. 99. 100.

FIGURE 1. 2. 3. 4. 5. 6. 7. 8. 9. 10. 11. 12. 13. 14. 15. 16. 17. 18. 19. 20. 21. 22. 23. 24. 25. 26. 27. 28. 29. 30. 31. 32. 33. 34. 35. 36. 37. 38. 39. 40. 41. 42. 43. 44. 45. 46. 47. 48. 49. 50. 51. 52. 53. 54. 55. 56. 57. 58. 59. 60. 61. 62. 63. 64. 65. 66. 67. 68. 69. 70. 71. 72. 73. 74. 75. 76. 77. 78. 79. 80. 81. 82. 83. 84. 85. 86. 87. 88. 89. 90. 91. 92. 93. 94. 95. 96. 97. 98. 99. 100.

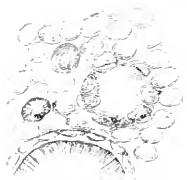


FIGURE 1. 2. 3. 4. 5. 6. 7. 8. 9. 10. 11. 12. 13. 14. 15. 16. 17. 18. 19. 20. 21. 22. 23. 24. 25. 26. 27. 28. 29. 30. 31. 32. 33. 34. 35. 36. 37. 38. 39. 40. 41. 42. 43. 44. 45. 46. 47. 48. 49. 50. 51. 52. 53. 54. 55. 56. 57. 58. 59. 60. 61. 62. 63. 64. 65. 66. 67. 68. 69. 70. 71. 72. 73. 74. 75. 76. 77. 78. 79. 80. 81. 82. 83. 84. 85. 86. 87. 88. 89. 90. 91. 92. 93. 94. 95. 96. 97. 98. 99. 100.

FIGURE 1. 2. 3. 4. 5. 6. 7. 8. 9. 10. 11. 12. 13. 14. 15. 16. 17. 18. 19. 20. 21. 22. 23. 24. 25. 26. 27. 28. 29. 30. 31. 32. 33. 34. 35. 36. 37. 38. 39. 40. 41. 42. 43. 44. 45. 46. 47. 48. 49. 50. 51. 52. 53. 54. 55. 56. 57. 58. 59. 60. 61. 62. 63. 64. 65. 66. 67. 68. 69. 70. 71. 72. 73. 74. 75. 76. 77. 78. 79. 80. 81. 82. 83. 84. 85. 86. 87. 88. 89. 90. 91. 92. 93. 94. 95. 96. 97. 98. 99. 100.



may be examined by the highest magnifying powers yet made,—by which statement I mean, of course, to imply that more may be learnt by the use of such high powers (1,000 to 3,000 linear) than by employing ordinary object-glasses.

**379. The Preparation of Embryonic Tissues for Examination with very High Powers.**—Contrary to general opinion, many of the softest textures may be investigated with the greatest facility after having been soaked in strong glycerine. In preparing these, the same steps which have been described in p. 300, must be carried out, but the glycerine used at first must be weaker, and its strength must be very slowly and gradually increased. Ova, at a very early period of development, can be prepared according to the principles indicated, and many important facts in connection with the first steps in the formation of tissues demonstrated with accuracy.

Some objections have been advanced by Dr. Ransom to this plan of investigation as applied to the *ovarian* ova of fishes. Dr. Ransom says, that the ammonia “dissolved the germinal vesicle and its contents.” Upon experiment, however, I found that so far from this being the case, numerous nuclei were displayed, and many new facts not to be demonstrated by examining the ova in water, were discovered. In pl. LVIII, figs. 345, 346, have been copied from Dr. Ransom’s paper, while the remaining figures were taken from my own specimens. See my paper, published in the Trans. of the Mic. Society for July, 1867, from which pl. LVIII has been taken.

Embryos of various ages may be injected with the Prussian blue fluid. The pipe cannot be tied in the vessels, as they are extremely soft. But if it is simply inserted, much of the injection will run onwards into the capillaries, and the escape of a certain quantity by the side of the pipe is a matter of no moment.

It is often advantageous to harden the tissue slightly by the addition of a little of the chromic acid glycerine solution, p. 297. When once the tissues have been fully permeated by glycerine, they may be dissected and manipulated in a manner which before was impossible, p. 294.

In the same way, extremely soft textures, like those of which the *calephæ* or jelly fishes are composed, or that delicate tissue entering into the formation of the vitreous humour of the eye of man and the higher animals may be prepared; and all the masses of germinal matter, or nuclei, which are very likely to be passed over in ordinary methods of examination, most clearly demonstrated. The most delicate infusoria and the germs of these and of the lower plants may also be thus prepared and preserved.

NEW VIEWS UPON THE STRUCTURE, FORMATION, AND GROWTH  
OF TISSUES.

To aid in establishing general conclusions concerning the nature of those wonderful processes of formation and growth peculiar to things living ought to be the aim of every one who devotes himself to the investigation of the minute structure of animal and vegetable tissues. But in these days, instead of being encouraged to follow the example set us by Harvey and Hunter and Bichat, observers are taught to devote themselves to the mere observation and demonstration of facts. Many, therefore, spend their lives in the pursuit of fact-hunting without pausing to enquire if the facts they discover are of any use and teach us anything, or if they affect in any way facts already known. Fact accumulation, the adding of fact to fact, seems to be the sole object in view.

On the other hand, there are men who never observe or experiment for themselves, who, in truth, look upon fact-finding and experimenting as inferior though necessary occupations, but who, nevertheless, keep in with the poor fact-finders, and make use of their results. From these contemplative intellects generalisations can alone proceed. In our days the philosopher, who never made a practical observation or discovered a single fact, feeling conscious of superior wisdom, is to indicate the precise fields in which inferior minds are to work, and to dictate the method of investigation to be pursued by those whom he looks upon as his workmen, condescendingly observing that as conclusions tend in this or that direction, more labour is required here, while it is useless working there, and new investigations must be set on foot to prove the truth of such and such an idea which he has evolved. And the philosopher is wise in the method he pursues, for it is easier to frame a generalisation and then select from the general heap of known facts particular facts in its support, than to examine the facts themselves one by one, to separate the true from the false facts, to experiment anew, and at last, after an honest survey of what is known, to endeavour to arrive at some generalisation.

Formerly those who advanced new views to explain the phenomena of living beings, not only performed the work of fact-hunting but tested the value of every fact, and only deduced their conclusions after much patient investigation and experiment. Of late a new method of making generalisations has been discovered, and many slow testing and analytical operations have been entirely discarded.

The philosopher and the fact-hunter seem to have discovered that they may keep their offices quite distinct and yet work to each other's great advantage. A compact seems to have been entered into. The fact-finders consenting to act as the servants or tools of the philosopher, provided he publicly acknowledges the high value of fact-hunting, and spreads the fame of the fact-finder as well as his own. Different schools of philosophy require differently constituted fact-finders, and as each new philosophy rises in popular favour, its own proper fact-hunters acquire the much-desired notoriety.

But do not many errors now pass current as observed facts, and do not many false generalisations interfere with the advance of real knowledge? *Must* not this be the case, if those who advance generalisations refuse to investigate for themselves, and practical observers confine themselves to mere observation and refrain from thinking and speculating concerning the facts they discover? Disadvantage to both must result from the attempt to draw a hard line between speculative thought and practical work. Useful hypotheses are much more likely to emanate from sound practical observers and experimenters than from purely speculative thinkers, who are obliged to obtain all their facts second-hand, and whose training has in too many instances been such as to render them quite incapable of distinguishing real facts from apparent facts, or of estimating the value or worthlessness of the evidence adduced in favour of the accepted interpretation of a particular appearance observed.

In the hope of encouraging students to *think* as well as work, I have ventured to offer many theoretical remarks in my book, though it is mainly devoted to practical subjects, and has been written with a strictly practical object. Though the speculations may soon have to yield to others, they will not be altogether useless and will at any rate afford some little interest, and I hope, stimulus, to those who do not find pleasure in mere laborious aimless observation.

In many parts of this book I have drawn attention to the great importance of special methods of preparing tissues. But in order to compare different textures with one another and the same texture at different periods of its growth, a uniform process of preparation must be adopted, or, in other words, all must be subjected to examination under precisely similar conditions. It has been shown that all textures may be easily manipulated and examined under the highest powers when immersed in glycerine, and that in every tissue obtained from a living being, *part* is *deeply stained* while *part* is left *colourless*, although it has been freely traversed by an alkaline colouring matter in solution, p. 107. The first exhibits certain common characters throughout nature, while the latter differs extremely in

the different textures and organisms in anatomical structure, physical properties, and chemical composition.

The matter which is coloured is, broadly, that which has been hitherto termed in different textures *cell*, *nucleus*, *cell contents*, *protoplasm*, *endoplast*, *corpuscle* (in some cases); while that which remains unchanged is that which is known as *intercellular fluid* or *substance*, *cell wall*, *membrane*, *fibre*, *periplastic substance*, &c. When the carmine fluid is used properly, the so-called cell, or in some cases the greater part of it, and the nucleus, or the latter only, are coloured, while the outer part of the cell and intercellular substance remain colourless, or are only tinted very faintly. It is often possible to demonstrate zones of colour one within the other, the *innermost* being invariably coloured most intensely.

By comparative observations upon the same tissues, at different periods of growth, a continuous but gradually altering relation has been demonstrated to exist between the so-called *cell wall*, *intercellular substance*, *cell contents*, &c., and the nucleus. I have adduced very many observations which seem to me to establish the important point that all the formed material was once in the state of the matter which receives the colour. So that in the formation of muscle, for instance, from the lifeless nutrient pabulum in the blood, the matter which is to become muscle passes through these different conditions:—

1. That of a soluble nutrient matter, or pabulum,
2. Germinal matter (nucleus),
3. Imperfectly developed formed material,
4. Fully developed formed material, muscular contractile tissue,
5. Disintegrated formed material, which becomes slowly reduced to a soluble state, and is converted, by oxydation, into new substances, some of which pass away, while others in their turn become pabulum for other kinds of germinal matter, such as white blood corpuscles and lymph corpuscles, which are therefore the agents concerned in the removal of the disintegrated material.

It will be seen that one very important fact gained by this enquiry, is the positive distinction between the *active living growing matter* of all tissues, and the matter which is *formed*, or *results from the changes occurring in the former*. This fact I endeavoured to establish in my lectures, given at the Royal College of Physicians, in April, 1861. I have since worked out changes occurring during the growth and formation of many tissues in detail, and I believe the above positions may now be considered as fully established.

The material stained by carmine must be regarded as matter in a transition state. It is not *tissue*, for it lives and grows, but it may at



length undergo conversion into tissue. It is living matter ;—and by the word *living*, I mean, that in this matter phenomena are observed which have not been explained—phenomena which cannot be accounted for by any known laws, which cannot be imitated artificially, and which have never been observed anywhere but in living things. Among the peculiar properties or powers of every mass of living matter, are—

1. The power of altering and appropriating certain soluble matters, and communicating to these, properties or powers of the same nature as those which the living matter itself possesses.

2. The power of moving in all directions—the passage of one part of a living mass moving to another part, so that one portion may advance *itself* in front of another portion, or encircle another.

3. The power of causing the elements of matter to take up definite relations towards one another, so that definite compounds, often exhibiting definite structures, may result, when the matter ceases to live.

4. The power of infinite increase.

By my observations I hope to establish the important conclusions that the formation of all tissues and organs, no matter how different their ultimate structure and office may be, is due to changes which have much in common taking place in matter in a very peculiar state, which cannot be correctly termed a *physical* state and is not in any way comparable with any other state in which matter is known to exist. These conclusions enable me to describe the structure of the most complex tissues and the changes which occur during their growth very simply. It is not necessary to discuss in any given case what is 'cell wall,' 'cell membrane,' or 'intercellular substance,' 'cell contents,' 'nucleus,' 'nucleolus,' 'primordial utricle,' 'protoplasm,' 'blastema.' For every structure consists of matter in two states :—*The living or germinal state and the formed and lifeless state.* All *increase*, multiplication, *division*, &c., is due to matter in the first state and to that alone. Living particles do not *aggregate* together to form one mass, but one mass may *divide* and *separate* into a vast number of distinct living particles, each of which may grow and become a mass like the first.

Every particle of the living or germinal matter comes from a pre-existing living particle,—and every piece of tissue, and formed matter of every kind derived from a living being was once in the condition of germinal matter.

Careful investigation of the relations which the *germinal matter* bears to the *formed material* at different periods of growth, and the careful study of these two kinds of matter in the various textures,

teach us the order in which the various changes occur and the employment of other terms is rendered superfluous.

A resumé of my views will be found in the new edition of Dr. Carpenter's Manual of Physiology. Brief extracts from my papers, and short notices, have from time to time appeared in various journals. An excellent analysis extending over twenty pages will be found in the American Journal of the Medical Sciences for January, 1867.\*

I propose now to draw attention to some of the facts which have led me to adopt the conclusions just referred to, and I must beg the reader carefully to study the different figures and accompanying explanations referred to. The illustrations have been drawn with the greatest care and no labour has been spared in their production. Some have been selected from my papers in the Phil. Trans. of the Royal Society, and I am indebted to the Council for permission to make use of them.

**380. Of Living or Germinal Matter.**—The smallest masses of living matter are spherical, and the largest mass always assumes the spherical form when free to move in a fluid or semi-fluid medium. Germinal or living matter is invariably colourless.

Very small particles of this living or germinal matter are represented in pl. LVIII, fig. 374. Now such particles cannot be termed cells, according to the ordinary definition of that word. Yet each consists of germinal matter with probably a thin layer of formed material upon its surface. Each of these may increase in size by the absorption of nutrient pabulum into its substance, and may then divide and subdivide into separate portions. In fact each possesses the properties usually regarded as characteristic of cell life. The mucus corpuscle which is represented in pl. XL, fig. 256, also consists of a mass of germinal matter which as it lies in the mucus or formed material exhibits movements as shown by the dotted lines. The

\* The present unsatisfactory state of Medical and Scientific Reviewing in England is much to be regretted. It is probably mainly due to the short-sighted policy of publishers who for the most part pay miserably and by measure, so that if a reviewer spends much time in condensing, and improving and re-writing his work, he will actually receive less than if he allows it to be printed in a crude state. It is pretty generally suspected by readers that the accident of friendship exerts too strong an influence upon the opinions expressed by reviewers, and it is not certain that the enthusiasm on the part of the press for certain scientific doctrines is excited solely by a disinterested consideration of their merits. Moreover the system which has become general among periodicals of calling the attention of readers to those works only of which copies have been presented to the journals, instead of to those which are published, cannot be too much condemned. All journals ought to refuse to receive copies as gifts, and surely all authors ought to refuse to allow their works to be presented for 'review.'

white blood corpuscle, pl. XXXIII, fig. 215, is another example of germinal or living matter which is invariably colourless and which as is well known exhibits slow movements. The amoeba which is represented in pl. XL, fig. 254, consists of living matter, and in its active state exhibits movements in every direction. These movements I consider to be *vital movements* for all attempts to explain them by physics and chemistry have signally failed.

The character of germinal or living matter can be studied very readily in the amoeba. These low forms of living beings are generally found in great numbers in water containing a little decomposing vegetable matter. If carefully examined under the  $\frac{1}{2}$ th of an inch object-glass the amoeba will be observed to alter in form. At various parts of the circumference protrusions will be observed. The protrusions consist of the material which forms the basis substance of the amoeba. It will be observed that this moving material is perfectly transparent and in it no appearance of structure can be discerned. It is true that granules and foreign particles may be seen embedded in it, but the matter in which the motor power resides is perfectly clear and transparent. Motion is communicated to the solid particles by the movements of the transparent living matter. Under certain circumstances the movements cease, and a change is observed to take place upon the surface. The outer part of the amoeba becomes condensed, and thus *formed material* results which protects the remains of the living matter within.

**381. The Conversion of Living Germinal Matter into Formed Material.**—The external surface of a mass or particle of germinal matter in contact with air or fluid becomes altered. In plain language, the living matter upon the surface dies, and according to the conditions under which death occurs, different substances may result. These may be solid, fluid, or gaseous. They may be soluble or insoluble in water. They may be soft or hard, coloured or colourless. They are *formed*, and their *formation* is in great part due to the relation which the elements of the living matter were made to assume towards each other, during the living state. This relation is definite, so that from the same kind of living matter under similar conditions the same formed substances result. The very same elements which lived in the living matter, always enter into the composition of the formed material.

The mode in which the formed material is produced will be understood by reference to fig. 355, pl. LVII. In *a*, *b*, and *c*, both germinal matter and formed material are undergoing increase. In fig. 356 the mass of germinal matter is dividing in the substance of soft formed material, a portion of which surrounds each of the

resulting masses, as seen in fig. 357, but the formed material is perfectly passive—as passive as a mass of mucus or fluid jelly would be in which such self-moving, growing, dividing matter was placed.

The production of formed material may also be studied in the conversion of the white blood corpuscles into the red. In the frog and newt, especially early in the spring, numerous white corpuscles will be found the outer part of which is undergoing change, losing its granular appearance, and becoming smooth and tinted. As the corpuscle advances in age this process continues until at last the oval red corpuscle is seen to contain only a small portion of germinal matter in the interior, as represented in pl. XXXIII, fig. 214. In mammalian animals generally this change goes much further, and the whole corpuscle gradually undergoes conversion into coloured formed material. The fully formed mammalian red corpuscle consists of matter in a colloid state, which very soon passes into a crystalline form. In some instances, as in the case of the blood corpuscle of the Guinea pig, this change occurs within a very short time after the corpuscle has ceased to move, as when it is withdrawn from the circulation of the animal and placed upon a glass slide. In figs. 213, 216, pl. XXXIII, some of these crystals formed from the red corpuscle of Guinea pig's blood are represented.

Another simple case, showing the formation of formed material from germinal matter, may be studied in cuticle, or in the cells upon the papillæ of the tongue. At first there is but a very thin layer of formed material upon the surface of the germinal matter, and this is soft, so that the mass may divide, and each portion may be invested with a thin layer of this soft formed material. Nutrient pabulum passes through it to the germinal matter within, and a portion of the latter undergoes conversion into formed material. The germinal matter increases, while at the same time new formed material is produced. This is shown in figs. 358, 359, 360, pl. LVII. In the last figure, a thick layer of formed material has resulted, which only permits a very little pabulum to pass through. The entire cell does not, therefore, increase in size; but the conversion of germinal matter into formed material still proceeds, so that at last a mere trace of the latter remains, and this often becomes liquefied and removed. Thus a space or cavity (vacuole) remains and marks where the living matter was situated.

The bodies represented in figs. 355 to 360 are termed cells. Cells of this simple character are very common, particularly in many vegetable textures. It will be noticed, however, that they differ from these last in the greater thickness of the formed material. Every one of these *cells* consists of a portion of *living germinal matter*, around

which is a layer of *formed material* or *lifeless matter* varying in thickness in different cases, but which has in all *resulted from the death of particle after particle of the first*.

That the formed material is deposited as I have described is proved by watching the changes which occur in such a structure as ordinary mildew, represented in pl. XLI, fig. 259. The various drawings of mildew, in different stages of growth, are careful copies from nature, and should be attentively studied with the aid of the explanations.

The *germinal matter* which in some of the plates is known by its granular appearance, and in others by its being coloured red, is in fact the only active part of the cell. Nothing can be said to *live* which does not consist of germinal matter. In pl. LXIII, fig. 393, and in pl. XLI, fig. 257, are represented some growing muscular fibres. The masses of germinal matter are large and well-formed. The so-called nuclei of the nerve fibres ramifying among them also consist of living or germinal matter. In tendon, and various forms of fibrous tissue, the so-called 'nucleus' is the germinal matter, and the fibrous matter is the formed material (*see* pl. LVII, fig. 369). So also in cartilage the same simple distinction can be made. The so-called 'intercellular substance' or 'matrix,' figs. 367, 368, is no more intercellular than the so-called 'wall' of an epithelial cell is *intercellular*.\*

In young tissues the proportion of germinal matter to the formed material is invariably very great—compare the young nerve cells, represented in pl. LXVIII, figs. 410, 411, with the fully-formed nerve cells in pl. LXVII. Also observe the relative quantities of germinal matter and formed material in the young, and advanced cells, represented in pl. LVII, figs. 358, 359, and 360.

### 382. Of the Nature of "Irritation" and "Inflammation."—

Let us now consider the wonderful effects which ensue from a change of the circumstances under which the "cell" is placed. Suppose the hard formed material which interferes with the access of pabulum to the germinal matter to be ruptured, or softened by the action of fluids, so that pabulum may more readily come into contact with the germinal matter—what happens? The latter increases. It absorbs the nutrient matter, and may even take up the softened and altered formed matter, which was itself produced from germinal matter at an earlier period. These stages are seen in figs. 361, 362. In fig. 363, the original

\* "Of the formation of the so-called intercellular substance of cartilage and of its relation to the so-called cells." Transactions of the Microscopical Society, March, 1863.

mass has divided into several, and in fig. 364 these are set free, and being now freely supplied with pabulum, in consequence of the absence of the thick layer of formed material upon their surface, as in figs. 358 to 360, they grow and multiply rapidly. Such are the changes which are considered to result from what is called "irritation," and which constitute the essential phenomena of "inflammation." In *irritation*, the access of pabulum to germinal matter is facilitated, because the protective external covering of formed material is removed or rendered more permeable by chemical or mechanical means. This is, I believe, the real action of the so-called chemical and mechanical irritants.\* It is, therefore, better not to employ the term irritation at all. Although all medical writers have freely used this word, no one has been able to explain exactly what he means by it.

The above view is capable of wider application. Heat acts as a "*stimulus*" to the development of the embryo chick, simply by facilitating *the access of pabulum to the germinal matter of the living embryo*. The heat *does not become the life*, for the life is there; but it is simply one of the conditions necessary for the manifestation of this mysterious active power. Without the influence of heat, the pabulum cannot get through the formed material to the already living germinal matter; but as formed material is expanded, and the permeating properties of the surrounding nutrient fluids increased by heat, the pabulum comes rapidly into contact with the living particles, which communicate to it the same wonderful power they already possess.

In the examples already adduced, the formation of the formed material takes place upon the *outer part* of the germinal matter, and as the cell increases in size the layers, first formed, are pushed out by those last produced. In many instances, however, formed material of another kind is deposited *amongst the particles* of germinal matter. In pl. XXXVIII, figs. 239, 240, are represented some of the young starch-holding cells of the potato. The so-called cell-wall is formed around the germinal matter, while the starch is deposited as small insoluble particles *in its substance*. In fact by the death of particles upon the surface of the living matter, the *cellulose* 'cell-wall' is formed, while, as a consequence of a similar change affecting the particles further inwards, *starch* results. In some of the cells no starch is found in the interior, but instead, the wall of the cell is greatly thickened by the deposition of a closely allied material upon its internal surface, layer within layer.

\* See a lecture on "First Principles." Dublin Medical Press, 1863.

As the starch-holding cells increase in size, the starch granules become enlarged by deposition of layer after layer upon their external surface. They still lie embedded in the germinal matter, and are separated from the cell-wall by a portion of it. This part of the germinal matter which lies just within the cell wall was known as the primordial uticle of the vegetable cell.

The fat cell, or adipose vesicle, is formed in precisely the same way, and fat may be deposited amongst the germinal matter of other cells, such as the cartilage cell, and in nerve and other cells in certain cases. The first formation of fat in a fat cell is represented in pl. LVII, fig. 365.

**383. Of the Nucleus.**—In the cell above described, the ‘nucleus’ takes no part. What, then, is the ‘nucleus,’ of which many examples will be seen in the drawings in the plates. The nucleus also consists of germinal matter. It may be regarded as a new centre which has arisen in a pre-existing centre. In many masses of germinal matter there are, in fact, two or three series of centres, one within the other. In one centre (nucleus) there may be one or a vast number of new centres (nucleoli). See pl. LVIII, fig. 347. The nucleus is composed of germinal or living matter, and it has appeared in germinal matter already existing. The vital power or force, whatever its nature may be, always manifests itself in a direction *from* centres,—particles of living matter move invariably in this direction, and as they move further and further away from the centre, their *vital* power becomes less, but new centres possessing increased vital power make their appearance. These new centres seem to acquire new power while they remain apparently quiescent. The process of acquiring vital power, the development of nuclei with high vital endowments, and the process of taking up a large quantity of pabulum, the rapid increase and multiplication of germinal matter, are opposed to each other.

**384. Of the term Cell.**—The term ‘cell’ was considered to be applicable to all the elementary parts of which organic bodies are composed, notwithstanding great differences which are well known to exist. Not only has it been arbitrarily laid down that a ‘cell’ involved the existence of a ‘wall,’ certain ‘contents,’ and a ‘nucleus,’ but distinct properties are still attributed to each of these parts respectively, although no one has ever been able to show that they really performed the offices assigned to them. It is obvious, however, that a small particle of living matter, pl. LVII, fig. 374, will not fall under the definition given of a cell, nor is it possible, by any reasonable interpretation of the terms employed, to bring white blood corpuscles and a host of other objects into the cell category.

To include these the definition must be totally changed. The difficulty of including many bodies under the old definition, combined with an implicit faith in its truth, has led many observers to affirm the existence of a cell-wall, although none was present, and at last the supporters of the old cell doctrine have taken refuge in the idea that the 'cell-wall' may itself be fluid and capable of running together like the film of a soap bubble!

The moving matter of the white blood corpuscles, the granular matter around the so-called nuclei of muscle, the contents (in part or entire) of the vegetable cell have been called 'protoplasm,' but those who have employed this word have not accurately defined what they desire to include under it. The nucleus still seems to be regarded as an object distinct from other parts of the cell which has certain special functions assigned to it.

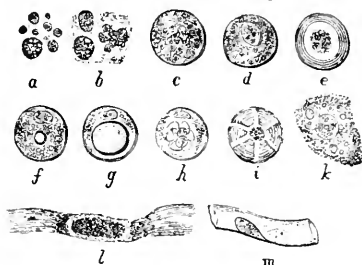
It should also be remarked that the meaning of many of the terms generally employed in describing the structure of, and the changes taking place in, cells, undergo great modifications from year to year, and thus is added another source of ambiguity and confusion.

To avoid entering into a long and tedious discussion as to the meaning which should be assigned to the words in general use, I have been led to use new terms when speaking of the essentially different parts of the cell or tissue. I apply the term *germinal matter* only to that which *lives, changes, converts, germinates, &c.* *Formed material*, on the other hand, never possesses any of these properties. It *has lived*, but is now lifeless; it may *be* changed, but it cannot change itself. In nutrition lifeless pabulum becomes living germinal matter, which becomes in its turn formed material, cell wall or intercellular substance, as the case may be. This last may accumulate or it may be formed in a fluid state, and disintegrated as fast as it is produced. The really important point is, that formed material of every kind was once germinal matter, and that new formed matter is deposited in one definite direction only, *from* the centre or *from* within, so that in an ordinary simple cell, the germinal matter is invariably within, then comes the recently produced formed material, and lastly the oldest formed material, which is therefore most external.

The views above given will be readily understood if the figures appended be attentively examined. At *a*, the smallest visible particles of germinal matter are represented. *b*. Small collections of germinal matter, with a little formed material between them (as in mucus). In one, portions are seen to project, and if these were detached each one would grow and give rise to new masses. *c*. A mass of germinal matter, with a very thin layer of formed material on its external



surface (cell-wall). *d*. Same as the last, but with a new centre of growth (nucleus), now comparatively quiescent, but capable of assuming active growth, appearing in the germinal matter. If *c* were exposed to unfavourable conditions the whole would be destroyed, but under similar circumstances the nucleus of *d* might alone resist these influences, and the conditions becoming favourable, would grow and produce new elementary parts, although of the original mass all but this small portion of the germinal matter had been destroyed. *e*. Thick layers of formed material, the whole of which were at one time in the state of germinal matter. *f*. Secondary deposits commencing to appear amongst the germinal matter, as fatty matter is precipitated amongst the germinal matter of the fat vesicle. *g*. A further stage of the same process. *h*. Separate masses of secondary deposits, as in the starch-holding vegetable cells. *i*. Deposition of formed material or secondary deposit in successive layers on the inner surface of the original capsule, spaces or intervals in which currents are continually setting in opposite directions during the life of the germinal matter, being left. *k*. Germinal matter and formed material which is granular, the particles of which are becoming resolved into several substances, as takes place in the elementary part of the liver (liver cells). *l*. Formation of fibres from germinal matter. *m*. Germinal matter belonging to and taking part in the formation of the walls of a tube.



**385. False Cells** can be made in many ways, and some so closely resemble certain natural cells that it would be difficult or impossible from mere microscopic examination to distinguish one from the other. This has led a number of observers to conclude that the cells formed in the living body are produced in the same way as these false or artificial cells. These erroneous conclusions have received considerable support, and they have been advanced in favour of the dogma lately forced into considerable notoriety that the formation of all living things is due to physical and chemical operations only.

It is really most remarkable that in these days clever men can be found who will waste their time in attempting to prove that the "cells" of which the textures of living beings are made up are formed by physico-chemical operations alone. The general statements which have been made have been refuted over and over again, and yet each one who advocates this view, of course with

various modifications in the details, falls, if not into the very same errors, at least into errors of a similar kind.

We have seen that every real "cell" passes through certain stages of being, and that no cell of any kind at an early period of its formation exhibits those characters which entitle it to be called a cell at all. The advocates of the physical theory altogether ignore this important fact. Because they can make artificially things like dead cells, they infer that living cells are produced in the same way, forgetting that the characters of the advanced cell have only been gradually acquired, and by a portion of matter which at first they themselves would have said was not a cell at all. They forget that the material out of which their cells have been made has the same composition as the cells themselves, while the living cell is made out of material of a composition totally distinct from it. They take a little viscid substance composed of fatty and albuminous matter and add with care a little water, and when they see under the microscope globular masses separate, they cry, "See how simply *cells* are made in nature out of similar ingredients to those which we operate upon." But they ignore what is well known to every one, that out of matter in which neither fat nor albumen, nor even any allied substance can be detected, a minute mass of clear transparent living germinal matter makes these and many other things.

Any child could grasp the facts and arguments in connection with this question if they were stated fairly, but it must be admitted that the statements often made and the inferences drawn in many of our elementary text books concerning cell formation are neither correct nor just; and some of them, although utterly untenable, are repeated over and over again with determined pertinacity. The fact that many of the statements used in favour of the physico-chemical fancies should be received at all, proves that most readers are content to accept the conclusions of an author without studying or enquiring into the facts upon which they are based; and that no matter how cogent the arguments against a particular doctrine may be, if these be judiciously suppressed, while those which seem to be in its favour are energetically and positively stated and sufficiently reiterated, the doctrine will be forced into general favour, and may hold its position perhaps for a long time.

**386. Of the Nutrition and Action of the Cell.**—It is generally supposed that when a tissue grows, certain matters existing in the blood pass from that fluid, undergo change, and are directly added to the tissue. In the nutrition of such a tissue as cartilage, it has been concluded that the matrix or intercellular substance is deposited directly from the blood, and that the masses of germinal





matter or cells take no active part in the formation of the matrix. But no one who holds this doctrine has attempted to explain by what means the pabulum becomes altered as it passes through the walls of the vessels and is changed in its composition so as to resemble the existing cartilaginous texture lying in the intervals between the masses of germinal matter.

It is quite certain that nothing having the composition of cartilage exists already formed in the blood ; and indeed those who teach that the process of nutrition is of the nature above indicated, are driven to attribute mysterious transforming powers either to the lifeless vascular walls, or to the equally lifeless tissue itself. It would be as unreasonable to attribute transforming powers to lifeless wood, or glass, or stone, as to fibrous tissue, cartilage, bone, &c.

It will have been observed that according to my view the changing transforming powers reside in the *germinal matter* alone. The facts advanced by me in 1861, concerning the nature of the germinal matter have not been overthrown. I have endeavoured to show, not that the germinal matter acts upon matter which passes by it and so changes it without undergoing change itself, but that every kind of formed material and tissue passes through the condition of germinal matter, and that therefore in the formation of fibrous tissue, cartilage, &c., pabulum from the blood is taken up by the germinal matter, becomes germinal matter and in its turn is gradually resolved into the matrix or intercellular substance.

The existence of germinal matter *before the production of formed material*; the continuity of the germinal matter with the formed material in tissues in process of development ; the circumstance of no case being known in *which formed material is produced without germinal matter* ; and the demonstration that fluids will pass through a comparatively thick *layer of formed material, and reach the germinal matter in the course of a few seconds*,—forced upon me the conviction that pabulum invariably passes to the germinal matter, and that it, or at least some of its constituents, undergo conversion into this living substance, and acquire its properties and powers, while at the same time other portions of the germinal matter lose their active powers, and undergo conversion into formed material.

So that pabulum invariably becomes germinal matter, and the germinal matter, not the pabulum, is converted into formed material. I have been accustomed to state these facts as follows :—Calling the germinal matter which was derived from pre-existing germinal matter *a*, the pabulum *b*, and the formed material resulting from changes in the germinal matter *c*, I say *b* becomes *a*, and *a* becomes converted into *c*, but *b* can never be converted into *c* except by the agency,

and, in fact, by passing through the condition, of *a*, figs. 370, 371, pl. LVIII. So far, then, it would seem that in the process of nutrition pabulum passes into living germinal matter, and is converted into this substance. The formed material or tissue which, in many cases, constitutes the chief increase in weight and bulk, has all passed through the state of germinal matter. The formation of this germinal matter from the pabulum is therefore the important part of the nutritive process. Similar changes occur in the nutrition of the simplest living creatures as well as in the most complex. In the higher animals the food introduced into the stomach becomes dissolved, and the solution is taken up by the germinal matter of the villi, the chyle corpuscles, and the white blood corpuscles. Changes occur in these masses of germinal matter, and the products resulting form the pabulum for the germinal matter which takes part in the formation of the various textures.

*Of the Action of the Cell.*—Now there can be no doubt that the *action* of many cells is due to the chemical changes exerted by oxygen upon the formed material. This gas combines with some of the elements and new compounds which often constitute the “secretion” of the cell are formed. It will be observed that the material to be oxydised is first *formed* through the agency of the germinal matter as has been already explained. The view has been generally accepted that oxygen is necessary to life. It is, however, certain that the principal demand for oxygen in living beings arises from the necessity for chemical change and destruction of material which is formed in consequence of the vital changes occurring in the germinal matter. Oxygen acts principally upon the surface of cells, upon the oldest part of the formed material, rather than upon the germinal matter embedded in it. It seems that the formed material is prevented from accumulating round the germinal matter of many cells by external agencies, among which the oxydising action of oxygen is the most important. In this way the formed material becomes resolved into more soluble substances, which are at once removed. Thus the passage of pabulum through the formed material and its access to the germinal matter are facilitated.

A cell may undergo the most active change without altering in size. The absorption of pabulum and the production of new germinal matter may be compensated for by the conversion of the latter into formed material, as the old formed material becomes oxydised and removed from the cell. Oxygen acts upon the *lifeless matter* of the cell rather than upon that which *lives*. It does not *support life* directly, but is necessary to the continuance of life, because it alone can convert the products of death and decay into soluble substances, which can

be readily removed. Fig. 370, pl. LVIII, will give an idea of the changes which take place during the process above referred to.

#### OF VITAL POWER.

**387. Of Life.**—The *vital* processes of growth, formation, and multiplication never occur unless germinal matter with its marvellous vital power is present. The formed material may be regarded as a product resulting from the collision of internal *vital*, and external *physical* forces. It, therefore, owes its properties partly to the changes occurring in the matter when in the living state, partly to the external conditions present when the matter was undergoing change, that is at the moment of its death.

I have tried to account for, by physics and chemistry, the changes which take place in the living or germinal matter, as far as can be ascertained by microscopical observation, but like all who have hitherto attempted to explain vital phenomena in this way, have signally failed. I have therefore framed an hypothesis in the hope that it may aid me in attempting to account for the facts. I suppose that a peculiar agency or force compels matter to assume temporarily the peculiar state characteristic of all living germinal matter, but of living matter alone (according to my definition). I venture to call this *vital power*. Although in the present state of our knowledge we can perhaps form no positive conception of the real nature of this wonderful power, any more than can be formed of the nature of gravitation, heat or electricity; by studying the phenomena we gain, it seems to me, very strong arguments against the view now very prevalent that vital power is but a peculiar mode or form of ordinary force, or corresponds to what we call the peculiar *property* of each different inorganic substance, by virtue of which it exhibits a constant crystalline form, a definite specific gravity, manifests a certain characteristic behaviour towards other substances, &c. Vital power, it is true, is only manifested under certain conditions which are fixed and definite, though very different for different living things; but is it necessarily a result of the influence of those conditions on inorganic matter? We are unacquainted with all the conditions absolutely necessary to life; but is it not almost certain that the external conditions, whatever they may be, might exist for any period without any form of life whatever being manifested?

Some will say,—vital power must be another mode or form of ordinary motion, because there is nothing else in nature that it can be. There is, it will be said, but one power capable of giving rise to the phenomena we term *vital*, and this is *force* of some kind or

other. But is not this begging the question, and is it not a mere assertion instead of a demonstrated truth to say that *all* the forces operating in nature are but different modes or forms of what has been called primary energy or motion? It is hardly yet proved that *all* the forces now recognised are mutually convertible, nor is it known how many forms or modes simple primary energy or motion may put on, while it is certain that many phenomena familiar to us cannot be explained by what we know of the forces of matter. How then can we be in a position to affirm that there is no power in nature capable of giving rise to vital phenomena but some form of force?

It is evident that vital power does not correspond to any properties manifested by ordinary inanimate bodies. For it is capable of being *transferred* from complex particle to particle. Moreover, it not only controls the manifestation of ordinary forces but gives rise to the formation of certain compounds and structures which are destined to come into use, not as soon as they are formed, but at some future time. A fully formed organ is not first represented by a microscopic germ of precisely similar structure, but by a mass without structure at all, and the fully formed tissues are preceded by the production of several less elaborate structures. It will therefore be seen that 'vital power' governs not only the present changes which present matter is to undergo, but prepares in advance for changes which are to occur at a future time. The formation of structures is, as it were, prepared for long before the compounds are produced out of which those structures can alone be made. While ordinary force seems for the most part to affect masses from the surface, vital power acts from the very centre of the most minute particles—new power seems as it were to be for ever *springing apace from the centre of particles of matter already under the influence of this power*. While ordinary force may change its form, it cannot cease or be annihilated; but there is no evidence to show that vital power changes its form, while, as far as is known, it does cease, and without undergoing conversion into any other kind of power or force. No one has yet proved that when living matter dies the vital power changes its form, and becomes converted into any kind of force which is set free; and although it has been asserted that more force is taken up in the formation of a brain cell of a man than in the formation of a vast quantity of vegetable tissue, there is no evidence in favour of such a hypothesis. It is but an authoritative dictum.

Numerous facts and arguments thus seem strongly in favour of the view that there exists in relation with every particle of matter that



is alive, a certain power characteristic of each different species of organism, and derived from a pre-existing particle, which exerts a special influence in determining the composition and properties of the substance that is to be formed. The power which determines the change which the matter is to undergo resides in, or at any rate affects the germinal matter of the cell only. And lastly, we conclude that this power is not of the nature of ordinary force because there is no example of ordinary force producing any effects like it, or exhibiting any analogy with force phenomena known to us, and we, therefore, attribute these effects to the working of some power which exists but which belongs to a different order or class, to any force or power whose workings are at present known.

Although, as was to be expected in these days of 'positive' knowledge, these views concerning vital power have met with considerable opposition, no one has yet explained in any more satisfactory manner the phenomena occurring in a living amœba or mucus corpuscle, nor is it very likely the attempt to do so will find much favour, seeing that there is no escape from the confession that we are not able to explain why the living matter moves and grows, making amœba material out of matter totally different in composition and properties. It is said to be unphilosophical to attribute the phenomena to amœba power, or amœba force, or amœba life, but as long as we remain ignorant and the question remains open, surely it is better to attribute the phenomena to a power we know nothing about than to assert that they are due to force.

Is not this very unsatisfactory attempt at explanation less blundering and more honest, inasmuch as it is a confession of ignorance, than the affirmation that amœba phenomena are due to the conditions under which the matter was placed, when we know not what we mean by the 'conditions,' while we do know that under no conditions we are acquainted with can an amœba result unless an amœba or its ovum or germ is already there?

But in the hope that those who differ from me in these matters will teach me how I may explain the facts without resorting to a vital hypothesis, I will endeavour to state my difficulties more distinctly.

I see under the microscope a little clear, transparent, structureless matter, which moves in various directions. Portions of the mass project at different points around the circumference. Some of these are again drawn into the general mass, others become detached, never to join again. Each separate mass grows, or takes up non-living matter around it, which non-living matter or certain of its elements becomes part and parcel of the growing moving mass. The

matter moves, and grows, and divides, and forms; and I find that everything that lives consists of matter like this, possessing like properties.

I find no matter in nature which moves, grows, divides, or forms save that which came from matter which did all these things before it, and therefore I call all matter which does all these things *living*, and matter which does not do these things—which does not exhibit the phenomena of movement in all directions, growth, division, and formation, *non-living*. I want to know why the matter grows, moves, divides, and forms. I am told that all this depends upon *force*, and that *force* is conditioned in the cell mechanism just as it is in the machine.

Then I urge that the living matter came from living matter like itself which lived before it, and this from pre-existing living matter; while, on the other hand, the machine was not derived from another machine, which after taking to itself iron and wood, or their elements, and other things entering into its composition, and thus for a time increasing in size, at length divided into two or more new machines.

Since force cannot of itself *form* the simplest possible machine or thing adapted to any definite end or purpose, what right have we to assert, contrary to all analogy, that force can form a particle of germinal matter which, mass for mass or weight for weight, is far more powerful than any machine ever made?

Lastly, as every machine results from the application of force *directed* by human intelligence and human will, is it probable that the cell which forms itself and performs of itself at least without human interference that which no machine has ever been made to do, is formed by unintelligent, purposeless, designless force?

But supposing living matter to be formed upon the same principles and to act in obedience to the same laws as the machine, we must assume that intelligence and will, or some substitutes for these, directed the application of the force by which each atom was arranged in its proper place according to the work which was to be performed and the nature of the things to be made—for are not the springs, wheels, and beams, &c., of a machine made and placed by force directed by intelligence and will in the places designed for them? If we do not admit this, there is really no analogy at all between the formation of living matter and the formation of a machine. It must be remarked here that it is a great mistake to compare the entire organism of man or animal with a complete active working machine. If any comparison at all is justifiable each individual cell or each minute particle of living germinal matter, which as it were contains within itself *directing power*, and *matter to be directed and arranged*, must be

compared with the complete machine in actual work, including its superintendent.

If I study the phenomena of a machine and those of a living organism, I find that although the results may be similar, the means by which the results are brought about are totally different in the two cases; and if I enquire how the machine was made and how the active organism was made, I find totally different methods have been pursued. In short, it seems to me that no comparison between the working machine and the living cell can properly be made.

But instead of the superintending agency or directing power being in close relationship with every minute living particle and capable of infinite division without loss of power, as a consideration of the facts of the case leads us to conclude, is it possible that the directing power may operate from a distance, without any definite location, and be capable of exerting its influence through any media that may be interposed, able to direct and control the arrangement of matter situated at infinite distance or infinitely near?

Having regard to the facts as we know them to be, how, I must ask, can we escape the conclusion that the principles upon which living matter grows and acts are totally distinct from those upon which machines are constructed and work?

But again I am told that non-living matter which never manifests phenomena exhibited by every particle of living matter, passes by imperceptible gradations into this last. Yet no one has adduced examples of matter exhibiting such gradations, and, as far as I can ascertain, the assertion is a mere dictum without the slightest foundation. It seems to me that the gulf which separates the simplest living monad from man is as nothing compared with that which intervenes between the simplest living particle and the highest and most complex form of non-living matter. Instead of a gradation there is an abrupt line, a separation which cannot be bridged over—a hiatus which becomes enlarged and more vast as knowledge increases, a distance immeasurable, infinite.

But scientific dogmatism will prevail, and the energetic disciples of the new philosophy will be well supported and will continue to assert their "positive" formulæ, in spite of opposition. 'The sun forms the muscle—the sun builds the nerve.' 'The living force-conditioning machine is formed by force.' 'The living cell is a laboratory.' While authorities less confident, ambitious of earning a reputation for caution, unwilling to subscribe to these bold doctrines, or commit themselves to such positive professions, will reiterate the assertion that ere long new facts will be discovered, and then the truth of such and such wonderful generalisation recently disclosed to an expectant

world will be indubitably established on a secure basis. At the same time, being careful to insist that those who think the tendency of observation is towards an opposite conclusion, are certainly mistaken, and in some instances bigoted and unworthy of credit. As if, where real knowledge was defective, anything save individual notoriety of the most evanescent kind, was to be gained by a man asserting himself to be the only real and true scientific prophet. Nevertheless, the prowess shown by the "positive" knight errants in assaulting the "fictitious entities" which have so long and cruelly tyrannised over the innocent and thoughtful must be admitted, and the disinterested longing exhibited by them to emancipate the human understanding from the tyranny of imaginary powers which have so long enchained it, would indeed be much to be admired, were it not clear, that these same deliverers, who would exultingly snap the gossamer chains spun round us during successive ages by the fictitious entities and imaginary forces, would deliver us to be bound hand and foot with the heavy fetters forged by unimaginative relentless force, and lead us into interminable blackness where all power of seeing and thinking would soon cease.

The physico-chemical school has, I think, only added to the confusion which has long existed in men's minds concerning the nature of the actions going on in living beings, and in spite of all its professed care, and exactness, denominates phenomena, which are essentially the same, *vital* or *physical*, according as they occur in a living organism or outside it. A change taking place in a glass vessel on the laboratory table is chemical, while if the very same change occurred in the body of an animal, it would be called vital. Now, surely the name given to any phenomenon should depend upon its own nature real or supposed, not upon the locality in which the phenomenon is manifested. It would be as unreasonable to call the same colour red or blue according as its position was altered without the least change in its appearance, as to call a change *electrical* or *chemical* if it occurred upon a table, and *vital* if it occurred in the organism of a living animal.

It will have been noticed that the word *vital* has been applied by me to changes and actions quite distinct from, and indeed in their nature opposed to, chemical, physical, &c., and I endeavour to define the precise seat of vital action, and to draw a sharp line between the *vital*, and merely *physical* and *chemical* phenomena.

**388. Of Living and Dead.**—The terms *living* and *dead* have for me a meaning somewhat different from that commonly accepted. If my arguments are sound the greater part of the body of an adult man or animal, at any moment consists of matter to all intents

and purposes as dead as it would be if the individual itself were deprived of life. [The formed material of the living cell is dead. The only part of the living cell and the living organism which is alive, is the germinal matter. Nothing can be regarded as alive or living but germinal matter in which vital changes alone take place. The phenomena of imbibition, osmose, &c., in cells, even the contraction of muscles and the action of nerves, are probably in themselves physical actions, although they were immediately preceded by, and are probably the direct consequence of actions purely vital. But for the vital phenomena those physical actions could never have occurred in the precise way in which they did occur, nor effect the purpose they did effect. Were it not for the vital actions, osmose, muscular contraction, nerve action, &c., would of course soon cease, and could not be resumed unless the conditions were all re-arranged as they were before. The formed material in which all these changes occur, could not have been formed without the previous manifestation of vital phenomena. We may go backwards as far as we can, but we shall always find vital actions concerned in bringing about the condition of things necessary for the particular physical and chemical changes which occur subsequently.

It will be asked if in nutrition the lifeless pabulum *suddenly* becomes living germinal matter, and if the latter *suddenly* dies, and assumes the condition of formed material. It is generally taught that the elements of the former are *gradually* built up to form the tissue, and that the living body *gradually* passes into the condition of death.

I daresay I shall find little favour in these days of implicit belief in continuous and uninterrupted changes and gradual transitions,—but all I can learn compels me to hold that the change from non-living to living and from living to dead is sudden, that there is no transition state whatever,—that matter is either living or non-living, and that no intermediate state is possible. The germinal matter itself is probably not in any one part capable of being measured, entirely living. There is matter which has lived, matter living, and matter which is about to live, but I imagine that the very instant the lifeless atoms come within the influence of the vital power of a living particle, they cease to be lifeless and live; and, on the other hand, the instant external conditions interfere with the continuance of the changes occurring in the living particle, it dies, its atoms rush together in a certain way to form a definite compound which thus suddenly comes into existence, and may remain as it was formed, or continue to undergo further chemical change, or become resolved into a number of new compounds.

The old idea that a living thing in dying gives rise to a new life has been accepted in too literal a sense. This notion still survives, and is now considered by many to represent the exact truth. It is supposed that before a plant springs from the seed, the latter becomes completely changed, its component substances completely disintegrated, and their elements re-arranged. That then these elements become combined to produce new compounds and rearranged to develop new forms. From what has been already stated, it must be obvious that my conclusions are at variance with this doctrine, and that both views cannot possibly be true. So far from considering that a new being can spring from the products resulting from the decay and disintegration of one existing before it, I hold this to be absolutely impossible. From the time when the seed was first developed in connection with the living parent plant to the time when it becomes a perfect living organism, living matter and of a particular kind has not ceased to exist during one moment of time. However dry and however old the seed may be, so long as it continues capable of germination it must contain living matter. The cells and fibres of the growing plant are due entirely to the growth and multiplication of living particles which were derived from the living matter of its predecessor—not to the rearrangement of elements resulting from the disintegration of any mere lifeless compounds entering into the formation of the seed or to the re-arrangement of the elements of substances resulting by the death of any pre-existing living thing. If life which influences matter ceases but for an instant it can never be rekindled in that matter. The fact of continuity in vital manifestations cannot be argued away. There is absolutely no break, and the new origin of life—spontaneous generation is as improbable,—may I not venture to say as impossible as the formation of matter anew.

#### THE STRUCTURE AND ACTION OF NERVOUS APPARATUS.

In no department of minute research have I found the particular method of investigation here advocated more useful than in studying the ultimate arrangement of nerve fibres and cells. Our views concerning the nature of nervous action will be necessarily much influenced by the general notion we may form concerning the origin and distribution of nerves. At this present time there is the greatest disagreement among authorities concerning fundamental questions. It is not even determined whether nerves terminate in ends or form continuous circuits,—nor whether they influence tissues by reason of their being in structural continuity with them or merely indirectly, in consequence of currents passing along the nerve fibres situated at some

short distance from the particles of tissue to be influenced. And it is not known whether the influence is produced by the passage of a continuous current varying in intensity, or by an interrupted current. Nor is there more accord as to the origin of nerves in centres; some holding that the fibres invariably originate in cells, others that some cells have no fibres at all connected with them. And of those who admit the first proposition, some think the fibre comes from the body of the cell, others trace it to the nucleus, while some profess to have seen it emanating from the nucleolus. Or, again, concerning the fibres, which unquestionably originate in nerve cells, it has been stated that some pass into nerve fibres, while others have no special relation to nerves at all. But it would occupy much more space than it would be advantageous to devote to it, were I to attempt to give even a very brief summary of all or even the most important of the conflicting opinions now entertained. And if I were to limit myself to any one organ the reader would be equally bewildered by the conflict of opinions, and by the multitude of assertions which pass for statements of facts. And if he try to sift the evidence adduced in favour of the views propounded, he will completely fail, because they rest upon observations which for the most part he will find himself unable to repeat.

I shall venture to refer very briefly to some of the general conclusions I have myself arrived at in connection with the structure and arrangement of nerves, by working according to the principles enunciated in page 292.

**389. Of Plexuses and Networks.**—Every one agrees that the larger nerve trunks are in many instances so arranged as to form plexuses or networks, to which various names have been assigned by anatomists, according to their position, general form, origin, &c.; but it was supposed that in many cases nerves pursued an almost direct course to their ultimate distribution, where they terminated in free extremities, in cells, or by becoming continuous with the texture they influenced. More careful observation has, however, demonstrated that all nerves before they reach their finest ramifications form microscopic networks or plexuses, arranged upon the same plan as the coarser networks above alluded to; and I have been able to demonstrate that the *finest ramifications* themselves constitute a *plexus or network, in which the component ultimate fibres are arranged in much the same manner as the dark-bordered fibres entering into the formation of one of the ordinary plexuses.*

Careful observations upon the arrangement of particular nerve plexuses in the same texture at different periods of development have convinced me that the *ultimate terminal plexus* of the

embryo becomes the plexus composed of coarser fibres of the infant and child, and the plexus made up of bundles of compound fibres of the adult. New *ultimate nerve plexuses* gradually come into existence as the constituent fibres of those previously formed grow and slowly become converted into thick nerve fibres. That a continuous development of new nerve fibres takes place in the adult is rendered almost certain by the facts demonstrated in many textures of man and the lower animals. The arrangement of nerve plexuses one remove from the terminal plexuses of the nerve fibres will be understood by reference to pl. LIX, figs. 378 and 379. The arrangement is the same as regards sympathetic, and spinal motor and sensitive, nerve fibres—except that in the latter the constituent fibres of the plexuses one or more removes from the terminal plexus are dark-bordered.

In all cases, as far as I can ascertain, the ultimate terminal fibres are pale and granular, exhibiting nuclei at varying intervals, but are distributed upon precisely the same plan.\* I am of opinion, therefore, that there is not such a thing as a true *end* to any nerve fibre. I must, however, admit that almost all the observations which have been made in Germany during the last few years are opposed to my view. Memoir after memoir has been published for the purpose of proving that nerves exhibit terminal extremities in several motor and sensitive organs. As investigation proceeds, this controversy becomes more interesting and exciting. Although

\* Not many years since, numerous observers considered that no fibre could correctly be termed a nerve fibre which did not exhibit the dark-bordered character, and many real nerve fibres were regarded as fibres of connective tissue. But since I demonstrated the very fine nerve fibres in many different textures, and showed that in all cases the really active peripheral part of the nerve was the terminal plexus, composed of very fine compound fibres often less than the  $\frac{1}{100000}$ th of an inch in diameter, numerous memoirs have appeared in Germany in which the authors endeavour to prove that exceedingly fine fibres pass off from what I look upon as the terminal plexuses, and end or terminate in epithelial cells. Allusion has been made to some of these in pp. 113, 128.

Pflüger has arrived at the conclusion that the nerves distributed to the salivary glands end by exceedingly fine filaments in the epithelial cells or their nuclei; but I do not think that in this organ any nerve fibres pass beyond the surface of the connective tissue upon which the secreting cells lie. I have never been able to convince myself that nerves pass to the epithelial cells in any of the situations indicated, nor have I seen any preparations at all conclusive. On the other hand there are many facts opposed to this view. Upon the whole, the evidence, so far, is strongly in favour of terminal networks beneath the epithelium of such tissues as mucous membrane and secreting glands. And as *secretion*,—the production of peculiar compounds by cell-agency differing entirely from the materials out of which they were made,—certainly takes place in many cases without nervous agency, much stronger evidence than any yet advanced ought to be adduced before the conclusion that nerves act directly upon the secreting cell is accepted.





Fig. 174. Microscopic view of the connective tissue of the cornea, showing the characteristic lamellated structure.

Fig. 175.

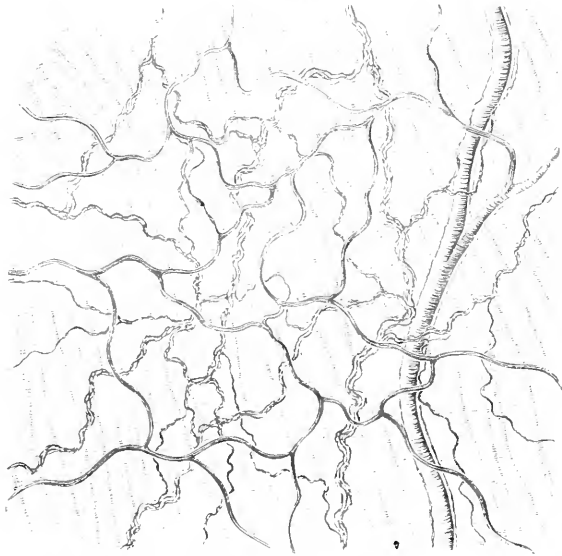


Fig. 175. Microscopic view of the capillary network of the cornea, showing the characteristic branching pattern.



my opponents are many and powerful, the facts in favour of my own view are now very numerous and almost every new investigation I attempt enables me to add more to the number. My conclusions rest upon observations made upon many different tissues and organs of vertebrata differing widely from one another, as well as upon those of numerous invertebrate animals. I cannot therefore yield. I consider that numerous specimens I have made fully justify me in maintaining the general proposition that in all cases the terminal distribution of nerves is a plexus, network or a loop, and hence that in connection with every terminal nervous apparatus there must be at least two fibres, *and that in all cases there exist complete circuits into the formation of which central nerve cells, peripheral nerve cells and nerve fibres enter.* All these elements are in structural connection with each other. I propose now to illustrate these general observations by one or two examples.

**390. The Distribution of Motor Nerves to Muscles.**—In pl. LX, fig. 380, the ultimate arrangement of the finest nerve fibres in voluntary muscle is represented. A full explanation will be found beneath the drawing, so that it is not necessary to enter into a minute description in the text.

The nerves distributed to the muscular fibres of insects are much finer and more delicate, and far more difficult of investigation than those of vertebrate animals. Many writers have been led into fundamental errors concerning the structure and arrangement of nerve fibres in this class of invertebrata. What really is a compound nerve fibre, composed of very many individual fibres, has been looked upon as a single nerve fibre. The nuclei of the finer nerve fibres have been entirely passed over. Muscular nuclei have been regarded as bodies, in which muscular nerve fibres end. A plexus formed by the compound nerve trunk at the point where it reaches the sarcolemma and it is about to break up and spread over the surface of this membrane, pl. LXI, figs. 381, 383, has been regarded as the terminal portion of a *single* nerve fibre *beneath* the sarcolemma and in contact with the muscular tissue.\*

In plates LXI and LXII, the manner in which very fine nerve fibres are distributed upon the sarcolemma of insect muscle is well seen. The reader should refer to the full explanation under each of the figures from fig. 381 to 387 inclusive. See also paper on the "Structure of the Sarcolemma of Insects," &c., Microscopical Journal for July, 1864.

The arrangement of the ultimate nerve fibres in involuntary or

\* Upon this subject see 'Controversy' Archives, vol. IV, p. 161, and a paper by Mr. Gedge, of Cambridge, in the July number of the Microscopical Journal, 1867.

unstriped muscular fibre will be understood if fig. 388, pl. LXII, be referred to. This is a drawing of a portion of some of the muscular fibre cells from the bladder of the frog, amongst which the finest ramifications of the nerve fibres are well seen. These nerve fibres form bundles and networks, having wide meshes in which the fine muscular fibres lie. Some of the muscular fibres are spindle-shaped, while others consist of three fibres radiating from a triangular central portion. It is obvious from the arrangement figured that the nerve fibres only influence the contractile fibre indirectly, for they are not anywhere in actual contact with the contracting material of the fibre, nor in any case can an end organ or any form of terminal apparatus be detected, nor are the nerves connected with the nucleus or with any part of the muscular tissue itself.

**391. Nerve Fibres distributed to Organs of Special and General Sensation.**—The ultimate arrangement of purely sensitive nerve fibres may be demonstrated in many of the terminal organs of man, and the lower animals,—such as the papillæ of the skin and mucous membrane in certain localities; but of all the organs studied by microscopists perhaps the larger papillæ (the fungiform papillæ) of the frog's tongue are the most beautiful as well as the most convenient, not only for investigating the terminal distribution of purely sensitive nerve fibres and for demonstrating the essential structure of a highly sensitive organ, but for ascertaining the relations and connections which nerve fibres exhibiting different functions, have with one another.

In the small portion of tissue constituting one of these papillæ we see striped muscular fibres, capillary vessels, purely sensitive nerve fibres forming an expanded terminal plexus or network at the summit of the papilla, motor nerve fibres distributed to the muscle, nerve fibres around the capillary vessel, and a few very fine nerve fibres ramifying in different parts of the papilla. All these are embedded in and held together by connective tissue, forming the body of the papilla, the summit of which is surmounted by a peculiar epithelium-like tissue, perhaps connected with the nerves and belonging to nerve texture, while its sides are covered with ordinary ciliated epithelium.

These papillæ have been studied by numerous observers, and, strangely enough, the latest writer has seen far less than many of his predecessors, probably because he has been less successful in preparing his specimens. Fig. 390 is a copy of Hartmann's figure taken from pl. XVIII, Müller's *Archiv*, 1863. It represents the mode of termination of the bundle of nerve fibres in the papilla according to this observer. It would probably be difficult to adduce a more striking





example of the destruction of beautiful textures by the process of preparation than was afforded by the preparation of which this drawing is a copy. Not only are the most interesting features of the papilla entirely lost, but the large dark-bordered nerve fibres are disarranged, and the most important part of them completely destroyed or rendered invisible. It is strange that any one should regard the appearances represented in the drawing as natural, or permit himself to conclude that the nerve ended so abruptly. No fine nerve fibres whatever could be seen, nor the nuclei which are connected with these, and which exist in great numbers. It would, of course, be useless to examine such a specimen with high powers, for nothing further could be discovered. As the same objectionable methods of enquiry are still advocated, it is not wonderful that those who adopt them have been led to the conclusion that high powers are useless, that appearances observed in specimens prepared according to other methods are fallacious, and that the observations of those who by adopting other plans of enquiry demonstrate new facts, are untrustworthy and products of the author's imagination. It is scarcely possible that the author of such a drawing as fig. 390 can place any confidence in an observer who ventures to represent the things delineated in fig. 389 as accurate copies of nature. He concludes the latter has simply appealed to his imagination. And this is perhaps the only way to defend his own position; for so many people are in these days ready to believe that an observer who professes to have seen what has not been seen before is but a fanciful speculator, and not an observer at all.

But it is quite certain that the most delicate constituent nerve fibres of the plexus in the summit of the papillæ of the frog's tongue (New Observations upon the Minute Anatomy of the Papillæ of the Frog's Tongue, Phil. Trans. for 1864,) can be readily traced by the aid of a twenty-fifth or fiftieth, if the specimen be prepared according to the directions given in p. 290. The *finest* nerve fibres thus rendered visible are indeed so thin and faint, that in a drawing they would be represented by fine single lines. Near the summit of the papilla there is a still more intricate interlacement of nerve fibres, which although scarcely brought out by the twenty-fifth, is very clearly demonstrated by a fiftieth! In this object the definition of the fibres, as they ramify in various planes one behind another, and interlace almost like basket work, is remarkable. Moreover, the flat appearance of the specimen as seen by the twenty-fifth, gives place to one of considerable depth of tissue and perspective. So that a more correct view of the structure of these papillæ is obtained by examining them with a fiftieth of an inch than with a twenty-fifth,

and even this leaves many points worthy of more extended investigation unsettled.

The fine fibres resulting from the subdivision of the dark-bordered fibres soon divide into numerous branches, which form a highly complex plexus, the subdivisions of which are connected here and there with numerous nuclei, as represented in the upper part of the papilla, fig. 389. It is impossible to follow these, but in fig. 391 is a diagram representing the probable arrangement. Each papilla seems to be connected with the nerve centre by special fibres and with neighbouring papillæ by commissural fibres, fig. 403, pl. LXVI. This arrangement, familiar to anatomists in the optic commissure, exists here and in all other nerve organs, pl. LXIII, fig. 394. The general arrangement of the vessels, muscular fibres, and other tissues, will be understood if the drawings in pl. LXIII be carefully studied.

**392. Of the Cells of Nerve Centres, Caudate Nerve Cells.**—The caudate nerve cells, of the spinal cord and brain have long been objects of attentive study. They are without doubt intimately concerned in the production of the highest nerve phenomena. The structure of these cells is very peculiar. Certain granules, lines, and inequalities in their substance, particularly upon the surface, have long been familiar to observers; but in 1864 I found some cells in which the arrangement of lines at different depths was very distinct. These lines could be traced, as is well represented in fig. 395, and shown diagrammatically in fig. 396. They clearly passed from each of the fibres across the cell into every other fibre proceeding from it. I could not but conclude that these lines marked the paths taken by the different nerve currents which traversed the cell.

The fibres proceeding from the cell consist of the same material as that of which the cell itself is composed, and are, as it were, drawn off from it.

Fine fibres resulting from subdivisions of the larger fibres leaving the cell, unite together to form single fibres, as represented in fig. 397. Thus is formed a dark-bordered nerve fibre. Every one of these fibres again divides and subdivides as it approaches its peripheral distribution. The manner in which this occurs will be understood by reference to figs. 399, 401, 402, pls. LXV and LXVI. See also figs. 193, 194, pl. XXX.

**393. Of spherical and Oval Nerve Cells.**—In the ganglia connected with the sympathetic nerves of the abdominal and thoracic cavities, in those on the posterior roots of the nerves, in the ganglia connected with the nerves of the heart and of many of the vessels of the



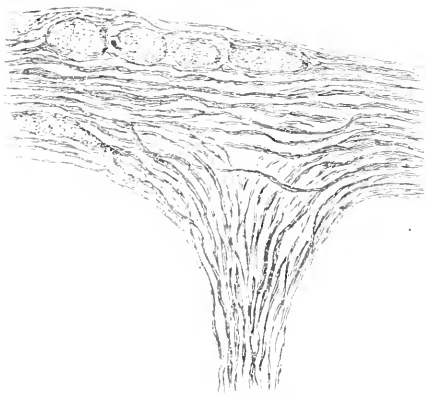




Fig. 84.



Fig. 85.



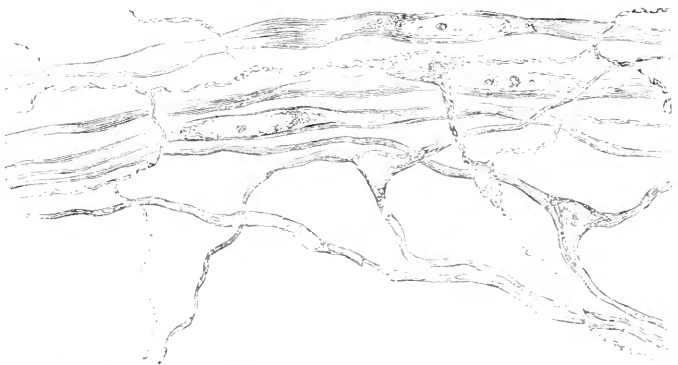
Fig. 86.



Fig. 87.



Fig. 84. Nerve bundle showing internal fibers and external sheath. Fig. 85. Branching fiber structure. Fig. 86. Branching fiber structure. Fig. 87. Branching fiber structure. Magnification X 100.





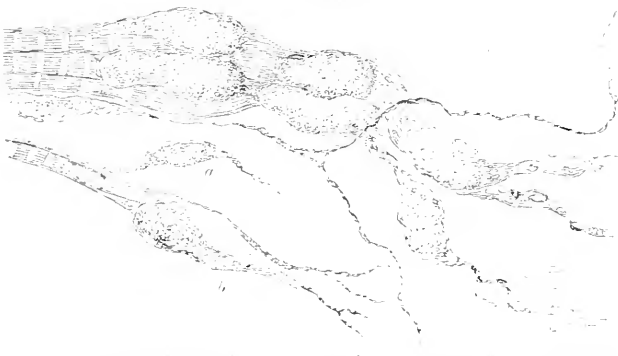
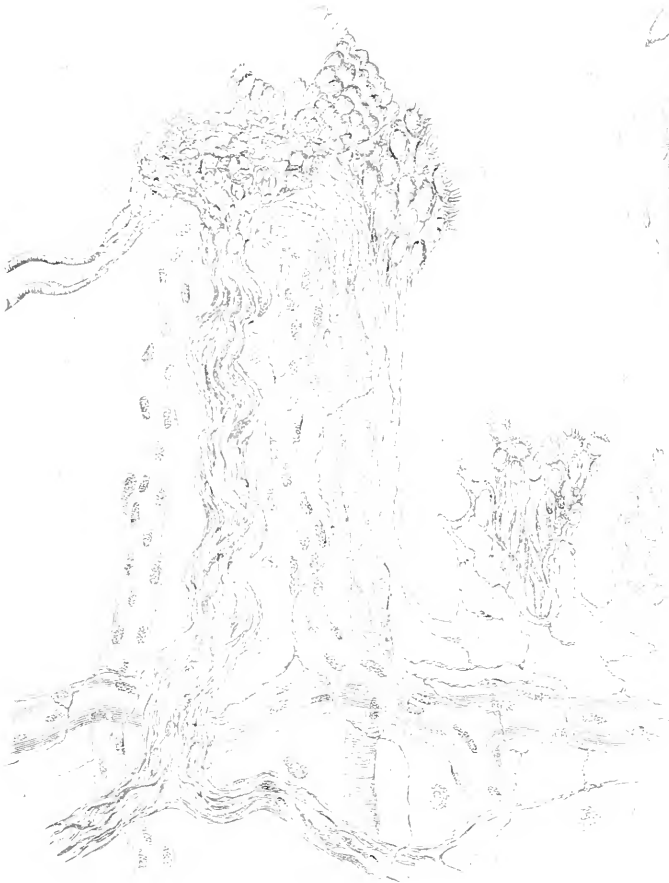
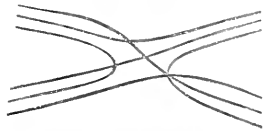


FIG. 4.





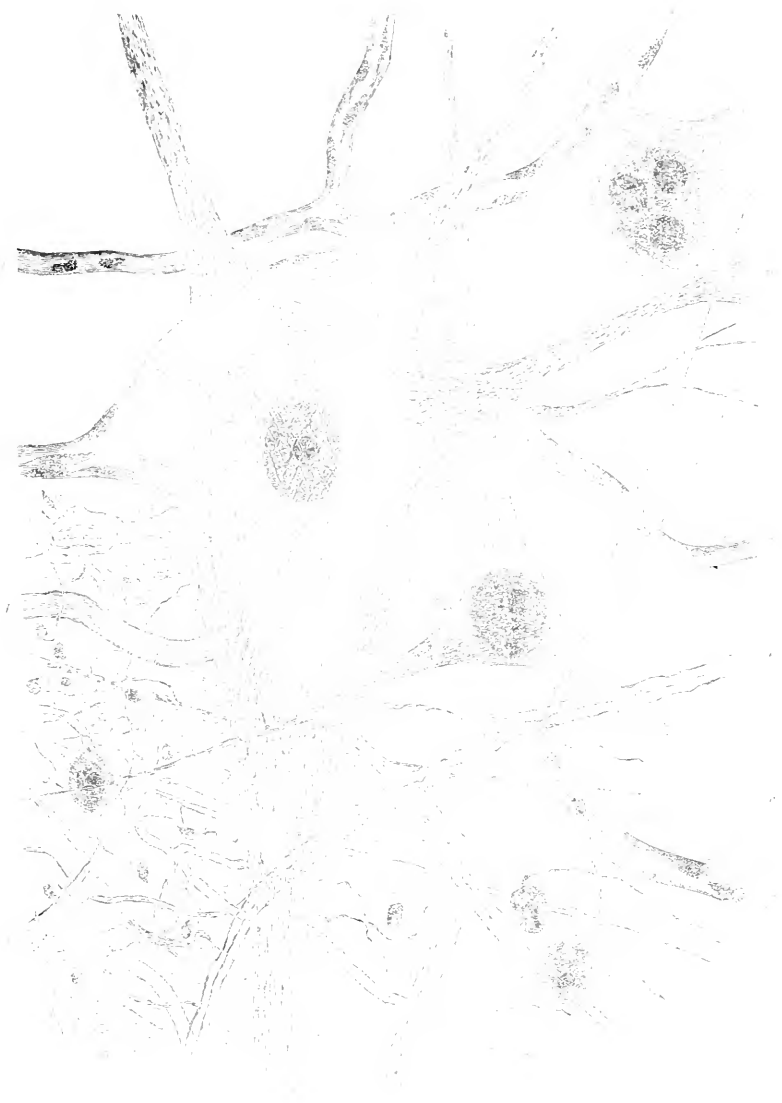


Fig. 1. *Phylloxera* on *Quercus*.

LARVA. The larva is small, oval, and has a very short, thick, and dark body. It is covered with a dense covering of small, dark, granular particles. The head is small and dark, and the legs are short and thick. The larva is shown in a crawling position on a branch.





Fig. 37.



Diagram to show the passage of a nerve from the center of a mass of cells to the periphery, and the manner in which it divides into smaller branches.

Fig. 38.

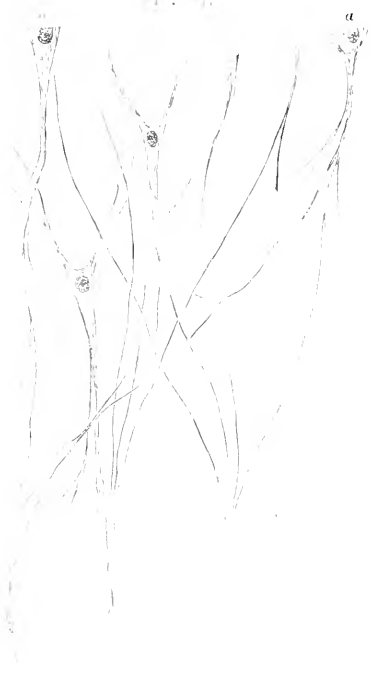


Diagram to show the manner in which a nerve divides into smaller branches, and the manner in which it divides into smaller branches, and the manner in which it divides into smaller branches.

Fig. 39.



Diagram to show the passage of a nerve from the center of a mass of cells to the periphery, and the manner in which it divides into smaller branches.

Fig. 40.

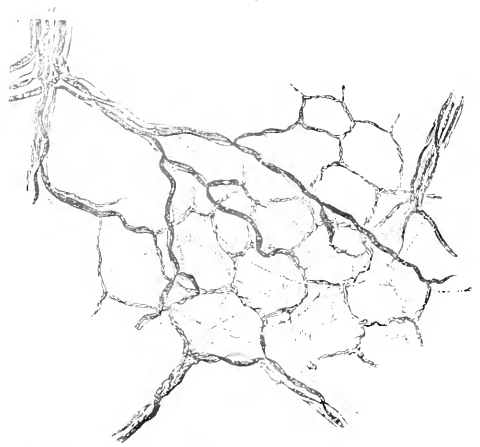


Diagram to show the manner in which a nerve divides into smaller branches, and the manner in which it divides into smaller branches, and the manner in which it divides into smaller branches.



Fig. 397.

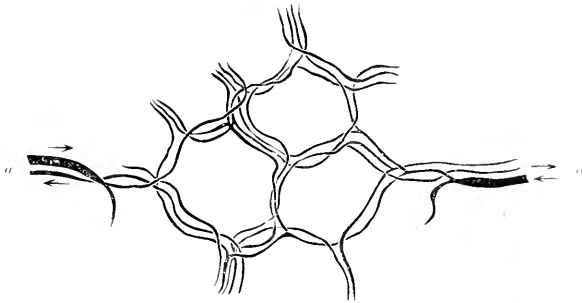


Diagram to explain the author's view of the arrangement of the motor nerve fibres in the "net works," *a a* dark colored and fine nerve trunks.

Fig. 401.



Central and peripheral parts of a neuron, *a* part of the main shaft, *b* part of the peripheral part, *a* and *b* are the same.

Fig. 400.

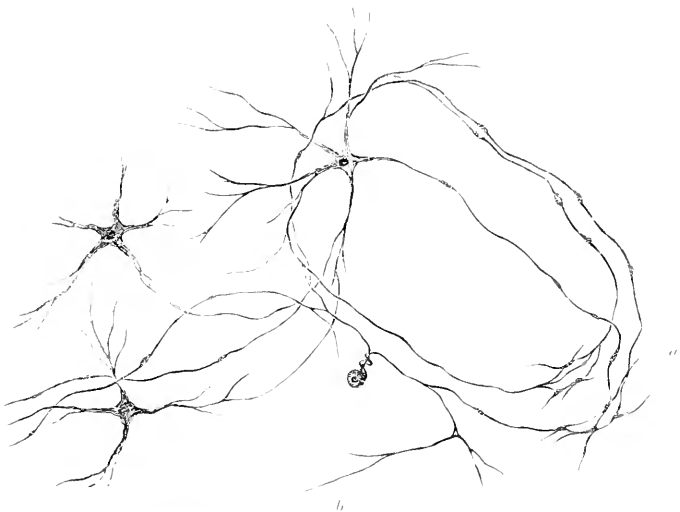


Diagram to show possible relation of fibres from caudate nerve cells of the spinal cord and fibres from cells in ganglia, as for example the ganglia on the posterior roots. *a* is supposed to be the periphery, the cell at *b* one of these in the caudon. The three caudate cells resemble those in the grey matter of the cord, medulla oblongata, and brain.

Fig. 402.

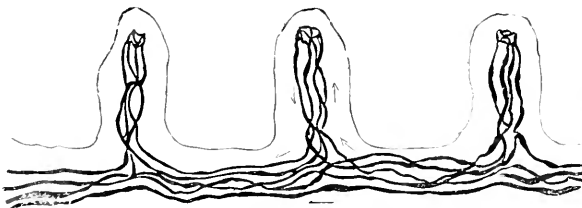


Diagram of three parallel nerve fibers, to show the arrangement of the nerve fibres. Each parallel is connected with its neighbors by common nerve fibres, as well as with the nervous centre.

Fig. 404.

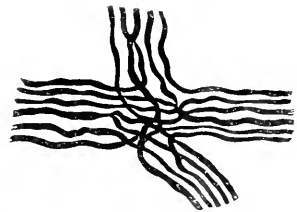


Diagram to show the course of parallel fibres in trunk trunks.





Fig. 394. Same as Fig. 393, X 200.



Fig. 395. Same as Fig. 394, with the stalk showing the same structure as in Fig. 393, X 200.



Fig. 396. Same as Fig. 394, with the same structure as in Fig. 393, X 200.



Fig. 397. The lower part of the stalk is very thick and shows a distinct structure. The upper part of the stalk is thin and wavy. The cell head is large and contains many granules. X 200.



Fig. 398.

Fig. 398. Same as Fig. 397, with the same structure as in Fig. 397, X 200.

PLATE IX. (Continued)

Fig. 399. Same as Fig. 398, with the same structure as in Fig. 398, X 200.

PLATE IX. (Continued)



Fig. 11



The mass of spores in the downy part  
 (a) is composed of two *b* and *c* and  
 is surrounded by a thin membrane  
 (d) which is composed of two layers  
 (e) and (f) and is covered with  
 small spores (g) which are  
 scattered over the surface of the  
 membrane.

Fig. 12



The spores of the *a* and *b* are of the same  
 size and shape as those of the *c* and  
 are scattered over the surface of the  
 membrane.

The spores of the *a* and *b* are of the same  
 size and shape as those of the *c* and  
 are scattered over the surface of the  
 membrane.





head, neck, and trunk, &c., of the frog, spherical, oval, and sometimes angular cells exist, which contrast remarkably in their structure with the caudate nerve cells just described. Although from some of these cells fibres had been traced, until recently, the opinion was very generally entertained that the cells in question had but one fibre connected with each of them, and Kölliker and others maintained that some of the cells were entirely destitute of nerve fibres,—that in short, *apolar*, *unipolar*, and *multipolar* nerve cells existed in the nervous system. But it is obvious that if the views advanced by me concerning the fundamental arrangement of a nervous apparatus were correct, all nerve cells must have at least two fibres proceeding from them—must be bipolar, and therefore that neither apolar nor unipolar nerve cells anywhere existed. Thus a doubt was cast upon the correctness of the observation concerning apolar and unipolar nerve cells, and it was necessary to re-investigate this matter with great care.

My observations on this point were published in the Phil. Trans. for 1863, and render the existence of apolar and unipolar cells so very doubtful, that some of those who had described them have since given up the notion, although they by no means assent to the general proposition which I think has been established by my observations. I was able to show that what appeared to be a single fibre proceeding from a cell really consisted of two fibres which diverged from each other and proceeded in opposite directions towards their destination, a fact greatly in favour of my own general views of the structure of a nervous apparatus, *see* p. 331, and fig. 223, pl. XXXIV. The fibres could be readily traced to the body of the nerve cell, where the straight fibre was seen to be continuous with the central portion, while the spiral fibre passed into the matter forming the circumferential portion of the nerve cell. By carefully studying the development of these nerve cells many points of great interest and importance, both as regards the structure and action of nerve centres were demonstrated. The reader may refer to the figs. in pls. LXVII and LXVIII, which have been taken from the original memoir. Amongst the fully formed cells are observed here and there some which are undergoing the process of development. Such embryonic cells are seen in the ganglia of full-grown as well as in those of young frogs. They are to be found at all ages and are being constantly produced at all times during the life of the animal, particularly during the spring, when the nervous system is in its highest state of functional activity. Observation has shown that the same process goes on in the sympathetic ganglia of man and the higher animals as well as in those on the posterior roots of the spinal nerves. *See* my paper on Apolar, Unipolar, and Bipolar Nerve Cells, &c. These and some other facts lead me to

think that cells belonging to this class are the organs in which nerve (electrical?) force originates; while the triangular cells of the brain and spinal cord already referred to should, I think, be regarded as points in which several currents starting from very different parts decussate, and perhaps where secondary currents are induced in fibres running parallel to those traversed by the primary current, rather than as the actual sources of nerve power.

Such investigations cannot fail to impress us with the wonderful character of the mechanism concerned in nervous phenomena, and lead us to conclude that the effects produced are to be attributed rather to the mechanism through which force works than to any mysterious or peculiar properties of the force itself. Let no one therefore conclude that anything is gained by regarding nerve force as electricity or some mysterious unknown correlative of ordinary force, of the nature of which we know nothing. If we admit it to be ordinary electricity, the problem is not solved; for it is obvious that its manifestations are due entirely to the peculiar arrangement of the nerve cells and fibres which constitute the mechanism for setting free and conducting the currents. It is not possible to conceive nerve phenomena without a special nervous apparatus, and it would be absurd to ignore this apparatus in considering the nature of nervous action. The action of the machine cannot be dissociated from its construction. But the construction of the apparatus and its maintenance in a state fit for action are due to vital power. The lowest, simplest, and least varied kinds of nervous action, like all other actions known in connection with the living elementary parts of living beings, are intimately connected with *vital* changes, and cannot be accounted for by physical and chemical laws only. When we ascend to the consideration of the higher and more complex nervous actions, we find reasons for concluding that the vital actions perform a still more important part. In the brain of man we have probably the only example of a mechanism possessing within itself not only the means of repair but the capacity for improvement and the power of increasing the perfection of its mechanism, not only up to the time when the body arrives at maturity, but long after this, and even in advanced life, when many of the lower tissues have undergone serious deterioration, and have long passed the period of their highest functional activity.

These examples will suffice to show how very much our ideas upon broad and highly important general principles may be modified by facts discovered in the course of investigations upon the structure of tissues conducted upon new principles of preparation. It is to be regretted how very little attention is paid to this highly important,

if subordinate, enquiry by many of those who profess to discuss physiological questions philosophically. Some seem to think that considerations about demonstrating anatomical details are beneath the notice of those who aspire to what they themselves call philosophical views. If it were possible that truth could be evolved out of a man's understanding, it would be absurd to spend time in making observations which may after all often turn out to be fallacious; but is not such a notion opposed to all experience? and is it not certain that real progress in many departments of philosophical enquiry is dependent upon improvement in our methods of working?

---

## APPENDIX.

**207a. On the use of Borax and Boracic Acid.**—Professor Ernst Brücke, of Vienna, has recently discovered that solutions of pure borax and boracic acid exhibit peculiar reactions upon albuminous substances. A 2 per cent. solution of boracic acid unlike most dilute acids does not retard the coagulation of the blood. In a solution of three parts by weight of pure melted boracic acid in 200 of water, muscular tissue removed from a recently killed animal will retain its contractile power for a much longer time than if immersed in pure water. In some experiments Brücke found that the muscles retained their contractility for twice the length of time. The muscles from the large water beetle continued to contract under the microscope for upwards of a quarter of an hour after removal. Brücke also employs a 2 per cent. solution of boracic acid for studying the structure of the red blood corpuscles. This acid has not yet been much employed by microscopical observers, but it is one which is likely to be useful in the preparation of many specimens. “Über das Verhalten lebendiger Muskeln gegen Borsäurelösungen.” “Über das Verhalten einiger Eiweisskörper gegen Borsäure.” “Über den Bau der rothen Blutkörperchen,” von Ernst Brücke, Band LV und LVI der Sitzb. d. k. Akad. d. Wissensch., April, Mai, Juni, 1867.

**322a. New Colouring Matter developed by Living Organisms, and giving very peculiar Spectrum Bands.**—Mr. Sheppard (*see* letter to the Rev. J. B. Reade, *Microscop. Journal*, July, 1867, p. 64) discovered that a velvet-like film found on stones lying beneath the surface of water, containing oscillatoriæ, confervoideæ, and other forms, developed a bright red tint after it had remained for twenty-four hours upon a piece of greasy paper. Upon further investigation it was discovered that a portion of the film when mixed with white of egg, diluted with a little water and left to stand for a night, gave rise to a solution of the colour of magenta dye.

This remarkable colour is due to the action of some living organisms upon the albumen which becomes less tenacious in consequence. The colour is not developed when the vegetable organisms have become stale. Moreover the colour disappears when

decomposition of the albuminous fluid takes place. The coloured albuminous solution was *dichroic*. It appeared red by reflected, and blue by transmitted light.

This coloured albuminous fluid is the only blue fluid known to Mr. Sorby which gives particular bands. Mr. Browning describes the spectrum as follows :—"Commencing at the least refrangible or red end of the spectrum, we find it cuts pretty sharply a short piece of the extreme red. Then we have a strong absorption band also in the red, corresponding to  $2\frac{1}{2}$  of the twelve lines given by Sorby's standard interference spectrum (pl. L, fig. 323). A second absorption band in the green commences at line 4, and tones off gradually into the spectrum just beyond line 5."

The spectrum of the fluid viewed by reflected light was found by Mr. Browning to be very different from the one by transmitted light just described. "A much larger portion of the red end is absorbed, but not so sharply. The strong band in the red is shifted towards the more refrangible end of the spectrum, cutting out the edge of the red, some of the orange, and most of the yellow. The second absorption band is wanting, but the greater part of the light of the spectrum is absorbed from a point between the fourth and fifth lines, and all the light is absorbed at the 7th. The part of the spectrum which should be yellow, has a strong tinge of olive green."

**327 a. Dr. Woodward's Improved Arrangements for taking Photographs of Microscopic Objects.**—The description of a more perfect and convenient plan than the one originally adopted by Dr. Woodward, at the Laboratory of the Army Medical Museum, Washington, U.S., has lately been forwarded by him to Dr. Maddox. I am glad to be able to introduce the communication here, for it is in itself of considerable interest, and shows, moreover, the high estimation in which this branch of microscopy is held by the Government authorities. *See* also p. 329.

"For the sake of convenience a camera box and table are dispensed with, and the operating room, having a window facing to the south, is itself converted into a camera by wooden shutters on the inside of the window, sufficient non-actinic light to enable the operator to move about freely being admitted through yellow panes in a sashed door. A small yellow pane is also let into one of the window shutters to enable the operator to watch the sky during an exposure and see when clouds are about to obscure the sun. The microscope with its body in a horizontal position, stands on a shelf, on the inner window sill, its feet fitting into brass sleets to insure accuracy of position, pl. LXIX, fig. 417. Covering the portion of

the window towards which the microscope points is a stout immovable shutter, having a square opening to receive a moveable piece which fits into it with a rebate, and is held in position by four wooden buttons. An aperture is cut in this moveable shutter (*see* fig. 414) of the same diameter as the short body of the microscope, and in a direct line with it; a light-tight connection is made between the two by a sliding brass tube (*b*) fitted to the shutter. This aperture can be opened and closed at will, to make the exposures, by a brass plate (*c*) playing over the outer face of the shutter on a pivot, which, passing through the shutter, is worked by a handle (*d*) from within the room.

“This brass plate is sunk into a shallow space cut in the shutter so as not to project beyond its surface. Over the plate and covering the aperture is fastened the glass cell (*e*) containing the blue copper solution. Immediately below the edge of this cell a piece of brass tubing (*f*) thirteen inches long, is screwed to the shutter, carrying at its extremity the microscope mirror (*g*), accurately centred opposite the aperture in the shutter. This mirror is adjustable from within the room by means of two steel rods (*h/h*) attached to its framework by ball and socket joints, and projecting into the room through small holes in the shutter. One of these rods moves the mirror upon its vertical, the other upon its horizontal axis. The heliostat stands on an iron shelf, outside the window, in such a position that its mirror is a few inches only distant from the microscope mirror and in a north-westerly direction from it, fig. 417, *a*.

“The frame for the plate-holder, instead of standing upon a table, is supported upon a narrow walnut car, running upon an iron track ten feet long, laid upon the floor at right angles to the plane of the window (*see* fig. 417). This car consists essentially of a base made of four pieces of wood joined together so as to leave an opening in the centre eight inches square, and two stout uprights, connected by a cross piece, which rise from the side pieces of this base and have a V-shaped way cut on their inner faces to receive the sliding sides of the top of the car. This top can thus be adjusted to any height, and clamped in position by wooden binding screws, so that negative plates of different sizes may be used if desired, and centred to the axis of the microscope body. The track (*see* fig. 415) consists of two wooden rails (*cc*) an inch high, screwed to the floor, upon which in turn are screwed flat iron rails (*bb*) whose inner edges project half an inch beyond the wooden rails. These iron rails are cast with a  $\Lambda$ -shaped projection on their upper faces, and the base of the car is furnished with small brass wheels (*aa*) correspondingly grooved to run on these projections. The car can be firmly fixed upon the track at any position by the following means. Through a hole

in the centre of the cross piece (*d*) connecting the sides of the car, runs a vertical iron rod (*e*) supporting at its lower extremity a cast iron cross piece with flat ends (*f*), which hangs transversely to the direction of the track through the central opening in the base of the car. The ends of this cross piece reach under the projecting inner edges of the flat iron rails (*bb*) and are made to clamp against their under surfaces by a nut with handles (*g*), screwing on the upper part of the iron rod, and binding on an iron washer on the wooden cross piece (*a*) through which the rod runs. The car can thus be fixed upon the track at any distance from the microscope within ten feet, and the distance that the surface of the negative is from the stage of the microscope in any given position is determined by a scale of feet laid off upon the floor close to one of the rails, and a scale of inches on the side of the base of the car (*see* fig. 417).

“To obtain the final focus of the image upon the plate in the plate holder, the following contrivance is used (*see* fig. 416). A perfectly straight cylindrical iron shaft (*a*), runs the entire length of the track, midway between the two rails, and at such a height as just to clear a groove on the under surface of the base of the car. This shaft has a shallow square groove cut in it along its entire length, and is supported at each extremity by brass bearings attached to the floor, in which it turns freely. To the posterior cross piece of the base of the car is fastened a bent brass bearing (*b*), projecting into the square opening in the base of the car and supporting two bevel gear wheels (*c*) working into each other. The upper and horizontal one of these wheels is turned by a vertical iron rod (*d*) attached to it, which is furnished at its upper extremity with a large milled head (*e*) and is supported by a collar (*f*) attached to the cross piece connecting the sides of the car. The lower and vertical wheel is pierced to allow the passage of the long shaft (*a*), and from the surface of the bore a small square iron tongue projects, exactly fitting the longitudinal groove in the shaft. By this means, no matter what may be the position of the car upon the track, the operator can rotate the shaft (*a*) through the pressure of this tongue upon the sides of the groove, by turning the milled head (*e*) connected with the bevel wheels. At the same time the car can be moved freely over the track, the iron tongue running smoothly to and fro in the grooves of the shaft. This long shaft (*a*) is made to turn the fine adjustment wheel of the microscope by the following means (*see* fig. 417). Attached to the edge of the shelf, upon which the microscope stands is a short iron axle parallel to the grooved shaft below, which turns freely in two flat brass bearings, and supports two wheels. One of these, a small brass wheel, is grooved and connected by a silk thread, removeable at pleasure, with

the fine adjustment wheel of the microscope, which is also grooved. The other, a large wooden wheel, is connected permanently by a flat leathern band with a similar wheel attached to the long iron shaft below.

“The steps in the process of photographing by the above described apparatus are as follows: The moveable shutter, with the apparatus attached, is buttoned in position, the heliostat set in place on the shelf outside the window and properly adjusted, so as to throw the rays reflected from its mirror upon the microscope mirror at the extremity of the rod on the shutter. The window shutters may now be closed and need not again be opened. The microscope is then placed in the proper position upon the shelf inside the window, and the silk thread adjusted which connects the fine adjustment wheel with the wheel on the edge of the shelf. The operator then, sitting on a stool in front of the microscope, and inserting an eye-piece, views the object as in the ordinary use of the instrument. This he is enabled to do without discomfort or injury to the eye, since the light transmitted by the solution of the ammonio-sulphate of copper, though *photographically* intense is *luminously* comparatively feeble, and is also deprived of a large proportion of its heat rays in its passage through that medium. While thus seated at the microscope, the operator makes the necessary adjustments of the stage, achromatic condenser, diaphragms, &c., having perfect control of the illumination by means of the steel rods attached to the mirror without the window and projecting into the room through the shutter. While making these adjustments he commands the fine adjustment wheel by the fingers in the usual way, the wheel readily slipping under the thread that connects it with the wheel on the shelf below. These adjustments being made, the best view and proper illumination of the object secured, the eye-piece is removed, and a black velvet hood attached around the edges of a hinged shelf projecting from the shutter (*see* fig. 417), is lowered so as to envelope all of the microscope but its body, thus preventing any leakage of light by the side of the objective. The operator now goes to the car, adjusts its position, noting its distance from the microscope by the scale on the floor and side of the base of the car, as already described, and clamps it firmly in place. He then sits down behind it and receives the image upon the surface of a piece of plate-glass held in the plate holder, viewing it with an eye-piece held against the glass plate, whose focus corresponds exactly with the anterior surface of this plate. He next turns the milled head that operates on the apparatus for turning the fine adjustment wheel of the microscope, until the image, viewed as just described, appears in exact focus upon the surface of the plate-







glass screen. The aperture in the shutter is then closed by means of the brass plate with handle inside the room, the sensitive plate substituted for the plate-glass screen in the plate-holder, and the exposure made by opening and closing the moveable shutter by the means already described. The time of the exposure is noted by the beats of a metronome, adjusted to strike at second intervals, the dimness of the yellow light in the room rendering the use of a watch inconvenient. Having obtained the negative, a stage micrometer is substituted for the object photographed, and its divisions, as projected upon a piece of ground glass held in the plate-holder, are carefully traced upon paper. By comparing these with a standard scale, the exact amplification of the object as represented in the negative, is readily calculated. Other negatives, representing the same magnifying power, can then be taken at any time by using the same objective and placing the car at the same distance from the microscope. The ordinary wet collodion process is the one used in the preparation of the negatives."

A bright white cloud illumination is obtained by throwing the beams of light from the mirror on to a piece of greased ground glass placed in the short body of the microscope, below the achromatic condenser, by which the interference lines so often resulting from employing the unmodified sun's rays are destroyed, and long exposures with high powers permitted. In some cases Dr. Woodward omits this ground glass. The objectives and amplifiers, as made by Mr. W. Wales, of Fort Lee, New Jersey, "are specially corrected so as to bring to one focus the rays in the violet end of the spectrum, where the actinic power resides."

The violet light is also "obtained practically pure by interposing in the solar beam reflected from the mirror a shallow cell, with plate-glass sides, containing a solution of ammonio-sulphate of copper."

When other objectives have been used they have been the ordinary achromatic lenses of other makers; the 1-50th of Messrs. Powell and Lealand gave excellent results in the hands of Dr. Curtis, as exemplified by the prints sent to this country. Dr. Woodward lately forwarded to Dr. Maddox some observations for publication (which were placed in the hands of the editors of the *Microscopical Journal*), on the result of comparative experiments made with a flint-glass prism and lens to increase the dispersion of the violet ray for the necessary exposure, and the ammonio-sulphate of copper cell, the light employed being the same, in both cases reflected from a plane mirror. It was found by using a sensitised collodion plate that the actinic power was in favour of the light transmitted through the cell; or, in other words, that the loss by dispersion was

greater than the loss by absorption in its transit through the cupreous solution. The details of this judicious and well-directed experiment testify to the care bestowed on these matters at the Government Laboratory. Dr. Woodward is about to institute a series of comparative experiments between the lenses of various makers, and between the lenses employed dry and *à l'immersion*. In a photomicrograph sent to Dr. Maddox by M. Nacet fils, as taken with his No. 7 objective by M. Lakenbauer, the areas of *Pleurosigma angulatum* are shown as nearly circular with a central dot, considered by these observers to be the foci of the little hemispheres.

**On p. 232** it should have been stated that in 1851 Dr. Hugh Diamond, in conjunction with Mr. Archer, succeeded in taking photographs of microscopic objects by the collodion process.

---

TABLES FOR PRACTISING THE USE OF THE MICROSCOPE AND MICROSCOPICAL MANIPULATION.

All who desire to become practically familiar with the use of the microscope, and to learn how to observe, are strongly recommended to submit to the routine which a conscientious practice of the experiments given in the following Tables necessarily involves. The author is fully persuaded that the patient prosecution of the course recommended, for two or three hours, on eight different occasions, will enable the student to obtain a practical acquaintance with the elements of microscopical enquiry, which it would not be possible for him to acquire so readily by reading, or indeed by any other plan.

---

TABLE I.

ARRANGEMENT OF THE INSTRUMENT FOR OBSERVATION.—DRAWING AND MEASURING OBJECTS.

1. Arrange the microscope for examining objects by transmitted light.—§ 34, pl. X, fig. 42.
2. Examine the objects upon the slide\* with the inch, and afterwards with the quarter of an inch object-glasses, using first the shallow, and afterwards the deep eye-piece.—§§ 4, 5, 6, pl. I, figs. 3, 4, 7.
3. Arrange the mirror in such a manner that the rays of light may pass through the object in a direct course or obliquely.—§ 10, pl. V, fig. 19.
4. Examine the same object under the quarter of an inch object-glass with the achromatic condenser, and afterwards without the use of this instrument.—§ 37, pl. XII, fig. 54.
5. Draw upon paper some of the objects † on the slide.—§ 41.
  - a.* Judging of the size of the paper by the eye alone.
  - b.* By placing the paper on a level with the stage.
  - c.* By measuring with a pair of compasses, p. 288.
  - d.* With the aid of the neutral tint glass reflector.—§ 44, pl. XIII, fig. 60.

\* Scales from the wing of a butterfly.

† Tracheæ from a caterpillar.

6. Ascertain the diameter of the objects upon the slide,\* using the inch object-glass and stage micrometer divided to 100ths of an inch, with the aid of the neutral tint-glass reflector.—§§ 44, 62, 64, pl. XIII, fig. 60. Pl. XII, fig. 56.
7. What is the magnifying powers of the two French and English object-glasses on the table? †—§ 63.
  - a. With the shallow eye-piece.
  - b. With the deep eye-piece.
8. Measure the angles of the crystals ‡ upon the slide.—§ 270\*, pl. XLII, fig. 268.

---

TABLE II.

EXAMINATION OF OBJECTS BY DIRECT OR REFLECTED LIGHT,  
TRANSMITTED LIGHT, AND POLARISED LIGHT.

9. Examine the objects upon the slide§ and carefully note the different appearances produced by examining them
  1. *By reflected light* as opaque objects, employing
    - a. The bull's-eye condenser.—§ 27, pl. XI, figs. 51, 52.
    - b. The Lieberkuhn and a stop.—§ 30, pl. XII, fig. 53.
  2. *By transmitted light*, employing
    - a. Direct rays.
    - b. Oblique rays.—Pl. X, fig. 42.
  3. *By polarised light*.
    - a. Employing the polariser and analyser only.—§ 23, pl. XIII, figs. 57, 58.
    - b. After placing beneath the objects a plate of selenite.
10. Examine some of the same crystals in different media, as described in §§ 136 to 143, pl. XIX.
  - a. In air.—§ 141.
  - b. In water.—§ 142.
  - c. In turpentine, oil, or Canada balsam.—§ 143.

\* Fragments of human hair.

† French quarter and one inch.—English quarter and one inch.

‡ Crystals of cholesterine.

§ Spherical crystals of carbonate of lime or starch globules.

11. Examine the different appearance of the globules of potato-starch and the pollen from different plants under the same circumstances.
12. Notice the microscopical characters of air-bubbles and oil-globules,\* and examine them by reflected and by transmitted light.—§ 137, pl. XIX, figs. 122, 123, 124, 126.

---

TABLE III.

ON MAKING CELLS FOR PRESERVING MICROSCOPICAL SPECIMENS.

13. Make a paper cell and attach it to the glass slide.—§ 114.
14. Make a thin cell with the aid of marine glue, and another with tinfoil.—§§ 117, 118.
15. Make some square thin cells of Brunswick black, and some circular cells with the aid of Mr. Shadbolt's apparatus.—§ 116, pl. XVI, fig. 91.
16. Cut some squares of thin glass, with the writing diamond.—§ 119.
17. Cut some circular pieces of thin glass, using the brass circles.—§ 119, pl. XVI, figs. 94, 95.
18. Make some thin glass cells in the manner directed in §§ 124, 125, pl. XVII, fig. 99, and when complete, grind the upper surface upon the emery slab, fig. 102.
19. Cut with the glazier's diamond some slips of glass, three inches by one inch, for slides.—§ 119, pl. XVI, fig. 92.
20. Make a cell of thick glass in the manner described in §§ 127, 128, pl. XVIII, figs. 109, 110.
21. Make a deep cell of gutta percha. The gutta percha must be softened in hot water and then moulded upon some object the size of the required cell.—§ 131.

\* Small air-bubbles can be obtained by shaking a little gum-water in a bottle. A drop may then be placed upon a glass slide. *Milk* affords oil-globules in abundance.

## TABLE IV.

ON MAKING MINUTE DISSECTIONS.—CUTTING THIN SECTIONS OF  
TISSUES FOR MICROSCOPICAL EXAMINATION.

22. Trace the nerves in the portion of tissue on the table.\* Pin it out on a loaded cork, and dissect it beneath the surface of water with the aid of a strong light condensed upon it by the large bull's-eye condenser, in the manner directed in § 144, pl. XXI, fig. 133.
23. Cut some very thin sections of the different soft tissues upon the table.†—§ 147.
  - a. Using the scissors.—Pl. XV, figs. 82, 83, 84.
  - b. Using the double-edged knife.—Pl. XIV, figs. 75, 76, 77.
  - c. Using Valentin's knife.—Pl. XV, figs. 78, 79.

All these instruments must be well wetted before the section is removed.—§ 147.
24. Place some small pieces of tissue in the compressorium and dissect them under the microscope in the manner described in § 149, pl. XXI, figs. 135, 136.
25. Make some thin sections of wood with the aid of the section cutter alluded to in § 156, pl. XXI, fig. 137.
26. Place some of the sections of pith or bone in thin cells, cover them with thin glass, and let them be preserved as dry objects.—§§ 141, 152.
27. Ascertain the effect of the different preservative solutions upon the appearance of the sections in the microscope.—§§ 99 to 113.
28. Place some of the sections which have been allowed to soak for half an hour in the fluid in which they are to be preserved in thin glass cells, and apply the thin glass cover, observing the precautions detailed in page 117. Remove the fluid outside, and anoint the edge with Brunswick black, which must be applied with a small brush.
29. Make a thin section of the injected tissue on the table and preserve it in glycerine, or in gelatine and glycerine.—§§ 100, 105, 106.
30. Dry another section and mount it in Canada balsam.—§ 143.

\* The skin or muscular tissue of any small animal, a part of a frog.

† A piece of tendon, cartilage, kidney, and liver of a sheep. These may be easily obtained of the butcher.



TABLE V.

KIDNEY.—MUSCULAR FIBRE.—PIG'S-SKIN.—PITH.—WOOD.—SPIRAL  
VESSELS.—VALLISNERIA.

31. Make thin sections of the sheep's kidney upon the table, and after washing them, subject them to examination with the inch, and afterwards with the quarter. Some may be examined in water and others in glycerine, one section should be mounted in the mixture of gelatine and glycerine,—§ 106. Observe the different characters of the tubes in the central and in the cortical portions of the organ, and endeavour to make out the following structures:—*Epithelium, basement membrane of the tubes, Malpighian bodies and capillary vessels lying between the tubes*, p. 142. The arrangement of the vessels may be satisfactorily demonstrated in an injected specimen.—Table VII.
32. Take a very small fragment of the muscular fibre of the skate or eel, and after tearing it up with needles, moisten it with water, and cover it with thin glass. Endeavour to find elementary fibres in which the tube of *sarcolemma* remains entire while the *sarcous* tissue within is ruptured.—§§ 212, 220, pl. XXVIII, fig. 184.
33. The portion of pig's-skin on the table has been allowed to dry by exposure to the air. Thin transverse sections are to be removed with a sharp knife, and subsequently moistened with water. In this manner a very thin section may be obtained, which soon regains its normal appearance. It may be mounted in any of the preservative fluids before alluded to.—§ 150.
34. Cut thin sections of the cornea and sclerotic of the eye which have been allowed to dry after having been pinned out on a board; soak them in a drop of water for twenty minutes or more, and examine them first with an inch object-glass and afterwards with a quarter.—§ 150.
35. Cut a thin section of the pith of the rush and examine it as a dry object; afterwards place it in fluid. Observe the air within many of the cells.
36. Demonstrate the circulation in the cells of *vallisneria spiralis*.—§ 259, pl. XXXVIII, figs. 243, 244.
37. Wash some pieces of the sea-weed in plain water, and preserve some of them in glycerine, and others in solution of chloride of calcium.—§ 260.

TABLE VI.

MAKING THIN SECTIONS OF BONE AND HAIR, AND MOUNTING THEM IN CANADA BALSAM.—MOUNTING DIFFERENT PARTS OF INSECTS.—SEPARATION OF DEPOSITS FROM FLUIDS.

38. Cut some thin sections of dry bone with the saw and grind them to the required degree of tenuity between the hones.—§§ 152, 218.
39. Upon microscopical examination they will be found covered with numerous scratches which must be removed by rubbing the sections upon a dry hone, and afterwards upon a piece of plate-glass.—§ 152.
40. When the sections of bone are sufficiently smooth, mount one of them at once in balsam, and treat another section with turpentine before immersing it in the balsam. Compare the different microscopical characters of these two specimens, pp. 78, 121.
41. Cut some thin transverse and longitudinal sections of hair, and examine them under the quarter of an inch object-glass. These may be washed in water and mounted in Canada balsam.—§ 155.
42. After drying several portions of the insects in a capsule over the water-bath (claws, antennæ, wings, eyes, spiracles), moisten them with turpentine and mount them in Canada balsam.—§§ 143, 251, 252.
43. After the deposit suspended in the fluid in the conical glass has subsided,\* a portion is to be removed with the pipette and placed in a cell, or in the animalcule cage, for examination.—§ 159, pl. XXII, fig. 141, pl. XVIII, fig. 112.
44. The fluid may then be allowed to evaporate spontaneously or by placing the slide under a bell-jar over sulphuric acid, pl. XX, fig. 131, and the residue mounted in Canada balsam.
45. Subject some of the infusoria in the specimen of water on the table to examination with a quarter of an inch object-glass.†—§ 248.

\* Small marine shells, sand, &c.

† Water containing pieces of animal and vegetable matter which had been kept for several days.

## TABLE VII.

OF INJECTING WITH OPAQUE AND TRANSPARENT MATERIALS.—  
PRUSSIAN BLUE FLUID FOR INJECTION.

46. Arrange the injecting apparatus conveniently (§ 165) and proceed to inject the artery supplying the eye-ball of the ox's eye on the table, with size and chromate of lead.—§§ 167, 170, 186.
47. *Eye*.—Introduce the pipe into the vessel running close to the large optic nerve, and tie it carefully, observing the precautions detailed in § 186. The eye must be allowed to remain in warm water until warm through, and the injecting material prepared in the manner described; it is to be mixed with melted size and strained immediately before use. When the injection is complete the eye is to be placed in cold water. Should it become very much distended by the accumulation of the injection within it, a puncture may be made in the cornea, which will permit the escape of the aqueous humour, and then the vessels may be more completely injected.—§ 186.
48. Prepare some Prussian blue injecting fluid.—§ 178.
49. *Frog*.—Insert an injecting pipe into the aorta of the frog in the manner described in § 186, and slowly inject the fluid.
50. The specimens having been completely injected portions may be submitted to microscopical examination.—§ 212.
51. The globe of the eye may be opened and portions of the following tissues removed with scissars, *ciliary processes* situated behind the iris, the *retina* (the most internal of the membranes within the globe), the *choroid* (external to the delicate retina). These, after having been carefully washed in water, may be submitted to examination in fluid with the inch object-glass. The ciliary processes and the choroid require to be well washed in order to remove the black pigment with which they are covered.
52. Portions of the lung and intestines of the frog may be removed, and after being well washed, may be submitted to examination. These are to be examined by transmitted light, and may be placed in glycerine. The inch object-glass should be employed in the first instance, and afterwards the quarter.

## TABLE VIII.

OF THE USE OF CHEMICAL REAGENTS IN MICROSCOPICAL  
INVESTIGATION.

53. Test the powder on the glass slide for the presence of carbonate,\* using the precautions detailed in § 309.
54. Each of the solutions † is to be diluted and separately tested for sulphates, phosphates, and chlorides.—§ 309.
55. Make some crystals of common salt.
- a.* By evaporating a solution rapidly to dryness on a glass slide.
- b.* By allowing the solution to evaporate slowly until crystals form, when a thin glass cover may be applied and the crystals subjected to microscopical examination.—§ 314, pl. XLII, fig. 270.
56. Fill one of the little bottles with capillary orifices with acetic acid.—§ 307.
57. Examine some of the white fibrous tissue ‡ under a quarter, before and after the addition of a drop of acetic acid.—§ 297.
58. Ascertain the effect of a solution of caustic soda§ upon the cells on the slide.—§ 301.
59. Describe the microscopical characters of the structures upon the glass slide,|| and sketch roughly their most important characters.—§ 57.
60. What is the nature of the substances forming the deposit in the glass ¶ ?

---

\* Chalk.

† Sulphate of soda, phosphates of lime, and ammonia and magnesia, and common salt dissolved in water to which a few drops of nitric acid have been added.

‡ The white tendon of a muscle of any small animal, as a mouse, &c.

§ Cuticle.

|| Eye and proboscis of a common fly.

¶ Potato-starch, blanket-hair, portions of feathers.

The foregoing tables contain exercises for the young student only, but any one who has been through these will be able to practice different branches of special enquiry not included in them if he refers to the different parts of the work in which these special matters are treated of:

On staining tissues, *see* § 196.

On collecting and dredging, *see* § 246.

On keeping the lower animals in aquaria and vivaria, *see* § 247.

On examining the lower animals during life, *see* § 248.

On demonstrating the contractility of muscle and ciliary movement, *see* §§ 256, 257.

On demonstrating vegetable tissues and the circulation in the cells of certain plants, *see* §§ 258, 259.

On the movements of living beings, and on vital movements, *see* p. 168 to p. 173.

On making sections of, and examining rocks and crystals, *see* § 265.

Of the microscopic structure of iron and steel, *see* § 270.

On preparing fossils for microscopical examination, *see* § 271.

On making and recording microscopical observations, and of the fallacies to be guarded against, *see* § 273 to § 278.

On spectrum analysis, *see* § 318 to § 322.

On taking photographs of microscopic objects, *see* part IV, from p. 229 to p. 280.

On using the highest magnifying powers, *see* § 355 to § 363.

On preparing specimens for examination under the highest powers, *see* p. 290.

For new views concerning the structure and mode of growth of tissues, *see* p. 308.

For new views concerning the nature of life, *see* § 387.

For new views on the structure and action of a nervous apparatus, *see* § 389 to § 392.

APPARATUS REQUIRED IN MICROSCOPICAL  
INVESTIGATION.

---

**I.—The Microscope.**

NECESSARY.

1. *Microscope* with large stage, firm tripod stand, coarse and fine adjustments, double mirror, and arrangement for inclining body; generally termed the *Student's Microscope*.—§ 15, pls. II, III, IV.

The student's microscope with two powers and bull's-eye condenser costs from five to ten guineas.

2. Pocket Clinical or Field Microscope, in case, with pipettes, test tubes, &c.—§ 20.
3. *Object-glasses*.—1. *The inch* magnifying from 30 to 40 diameters, the glasses of which can be removed one by one, so that lower powers can be obtained.  
2. *The quarter* of an inch magnifying about 200 diameters. These glasses should *define well*, the field should be *perfectly flat* and free from *coloured fringes*, and they should admit a sufficient amount of light.—§ 6, pl. I, figs. 7, 8.

ADVANTAGEOUS.

*Large microscope* provided with moveable stage and all the modern improvements.—§ 16.

With two powers, this instrument costs from 20 to 30 guineas.

*Binocular microscope*.—§ 17, pl. VI.

*Two-inch object-glass*.—§ 6.

*Eighth of an inch*.  
*Twelfth of an inch*.  
*Twenty-fifth*.

**II.—Accessory Apparatus.**

4. *Diaphragm plate*.—§ 14, 36, pl. I, fig. 9.
5. *Bull's-eye condenser*.—§ 27, pl. XI, figs. 51, 52.
6. *Universal condenser*. *Gillet's achromatic condenser*.—§ 38.
- Polariscope*.—§ 23, pl. XIII, figs. 57, 58.
- Spot glass*.—§ 33, pl. XII, fig. 55.

*For Artificial Illumination.*

## NECESSARY.

7. Small paraffin lamp.—§ 25, pl. XI, fig. 47.

## ADVANTAGEOUS.

- Smith and Beck's camphine lamp, or Mr. Highley's gas lamp. § 26, pl. XI, fig. 49.  
Bockett Lamp. Pl. XI, fig. 48.

**III.—Apparatus for Drawing Objects.**

8. *Neutral tint glass reflector.*—§ 44, pl. XIII, fig. 60.  
9. Common hard pencils, steel pens, Indian ink, fine Bristol board, smooth white paper.

**IV.—Apparatus for Measuring Objects and for Ascertaining the Magnifying Power of the Object-Glasses.**—§§ 58 to 66.

10. *Stage micrometers* divided into 100ths and 1,000ths of an English inch.—§ 60.  
*Neutral tint glass reflector.*—§ 44, pl. XIII, fig. 60.  
Nobert's lines, which may be used also as *test objects.*—§ 61.  
Maltwood's finder, or the arrangement described in p. 42.

**V.—Instruments and Apparatus for General Purposes.**

11. *Wire retort stand.*—§ 70, pl. XIV, fig. 69. *Water bath.*—§ 73, pl. XIV, figs. 73, 74.  
12. *Tripod wire stands.*—§ 71, pl. XIV, figs. 71, 72.  
13. *Spirit lamp.*—§ 69, pl. XIV, fig. 70.  
14. *Evaporating basins.*  
15. *Watch glasses.*—§ 85.  
16. *Thin glass.*—§ 84.  
17. *Plate-glass slides.*—§ 83.

**VI.—Instruments for Making Dissections and for Cutting Thin Sections of Soft Tissues.**

18. *Common scalpels.*—§ 74. *Valentin's knife.*—§ 77, pl. XV, figs. 78, 79.  
18a. *Double-edged scalpel.*—§ 75, pl. XIV, fig. 75. *Spring scissors.*—§ 79, pl. XV, fig. 84.

## NECESSARY.

19. *Scissors*.—Ordinary form and two small pair, one with curved blades.—§ 79, pl. XV, figs. 82, 83.
20. *Needles* mounted in handles.—§ 80, fig. 80.
- 20a. *Needles flattened* near the points.—§ 80.
21. *Forceps*.—One pair of ordinary dissecting forceps, and one pair with curved blades.—§ 81, pl. XV, figs. 85, 86.

## ADVANTAGEOUS.

*Compressorium*.—§ 149, pl. XXI, figs. 135, 136.

*For Dissecting under Water.*

22. *Glass dishes* of various sizes from an inch to two inches in depth.—§ 144.
23. *Loaded corks*.—§ 145, pl. XXI, fig. 134.
24. *Fine pins* and *thin silver wire*.
25. *Tablets* of wax and gutta percha.—§ 146.

*Large bull's-eye condenser*, for condensing a strong light upon the object.—§ 145, pl. XXI, fig. 133.

*For Cutting Thin Sections of Hard Tissues.*

26. *Saw* with fine teeth, for cutting thin sections of bone.—§ 152, pl. XXI, fig. 138.
27. *Hones* for grinding the sections thinner and polishing them.—§ 152.
28. *Strong knife* for cutting thin sections of horn, &c.—§ 155, pl. XV, fig. 81.

*Section cutter* for cutting thin sections of wood.—§ 156, pl. XXI, fig. 137.

## VII.—Cement.

29. *Brunswick black*, containing a few drops of a solution of India-rubber in coal naphtha.—§ 91.
- 29a. *Bell's cement*.—§ 90.
30. *Marine gluc*.—§ 92.
31. *Gum water*.—§ 97.
32. *Gum* thickened with *starch* or *whiting*.—§ 97.
33. *French cement*, composed of lime and India-rubber.—§ 98.
34. *Spirit and water*.—§ 99.
35. *Glycerine*.—§ 100.

*Gold size*.—§ 87.

*Solution of shell-lac*.—§ 89.

*Gelatine and glycerine*.—§ 106.



## VIII.—Preservative Fluids.

## NECESSARY.

36. *Solution of naphtha and creosote.*—  
§ 102.  
37. *Chromic acid.*—§ 104.  
38. *Turpentine.*  
39. *Canada balsam.*—§ 94.

## ADVANTAGEOUS.

*Gum and glycerine.*—  
§ 107.

## IX.—Apparatus Required for Making Cells and for Cutting and Grinding Glass.

40. *Brass plate* for heating slides to which marine glue is to be applied.—§ 72, pl. XIV, fig. 68.  
*Cements* before enumerated.—§§ 87 to 98. *Shadbol's apparatus.*—  
§ 116, pl. XVI, fig. 91.
41. *Small brush* made of bristles.
42. *Tin foil* of different degrees of thickness.—§ 118.
43. *Writing diamond.*—§ 119, pl. XVI, fig. 94. *Brass rings* for cutting circles of thin glass.—  
§ 119, pl. XVI, fig. 95.
44. *Glazier's diamond.*—§ 119, pl. XVI, fig. 92. *Wooden forceps* for holding glass slides.—§ 82.
45. *Flat stone* or *pewter plate* for grinding glass.—§ 120.
46. *Emery powder.*
47. *Old knife* and small chisel for cleaning off superfluous glue.—§ 123, pl. XVI, fig. 93.
48. *Solution of potash* (liquor potassæ).
49. *Sections of glass tubes* and of thick square vessels, of various sizes, for making cells for the preservation of injections.—§ 127, pl. XVII, figs. 101 to 105. *Shallow concave glass cells.*  
*Moulded glass cells.*—  
§ 130.

## X.—Apparatus for Preserving Objects in Air, Fluid, and Canada Balsam.

50. *Cells* of various sizes, before enumerated.—§ 126, pl. XVII, fig. 100.  
*Brunswick black.*  
Gum thickened with whiting.—§ 97. *Apparatus* for pressing down the thin glass cover while the cement is drying.—  
§ 96, pl. XX, fig. 128.
51. *Thin glass* cut of the requisite size.

- | NECESSARY.  | ADVANTAGEOUS.  |
|---|--|
| 51a. <i>Preservative solutions</i> .—§§ 99 to 113.  | Live cells for keeping bodies alive.   |
| 52. <i>Watch glasses</i> to soak sections in the preservative fluids.—§ 85.   |  |
| 53. <i>Glass shades</i> to protect recently mounted preparations from dust.—§ 86, pl. XVI, fig. 87.                       | <i>Bell jar</i> with vessel for <i>sulphuric acid</i> .—Pl. XX, fig. 131.                        |
| 54. <i>Brass plate</i> .—§ 72, pl. XIV, fig. 68.<br><i>Canada balsam</i> .—§ 94.<br><i>Needles</i> to remove air bubbles. | <i>Air-pump</i> to remove air bubbles from the interstices of a tissue.—§ 143, pl. XX, fig. 129. |

**XI.—Apparatus Required for the Separation of Deposits from Fluids and for their Preservation.**

- |  |   |
|--|---|
| 55. <i>Conical glasses</i> .—§ 157, pl. XXII, fig. 141.                                  | <i>Glass troughs for Zoophytes</i> .—§ 248. |
| 56. <i>Pipettes</i> .—§ 158, pl. XXII, fig. 140.   |   |
| 57. <i>Wash-bottle</i> .—§ 163, pl. XXII, fig. 143.                                      |   |
| 58. <i>Cells for examining infusoria</i> .—p. 66, pl. XVIII, fig. 112, pl. VII, fig. 28. |   |
| 59. <i>Animalcule cage</i> .—§ 134, pl. XVIII, fig. 112, pl. VII, fig. 28.               |   |

**XII.—Instruments and Apparatus Required for Making Injections.**

- |  |   |
|--|---|
| 60. <i>Injecting syringe</i> , holding from half an ounce to an ounce.—§ 165, pl. XXIII, fig. 151. |   |
| 61. <i>Pipes</i> of various sizes.—§ 165, pl. XXIII, figs. 156, 157.                               |   |
| 62. <i>Corks</i> for stopping the pipes.—§ 165, pl. XXIII, fig. 150.                               | <i>Stop cocks</i> .—§ 165, pl. XXIII, fig. 155. |
| 63. <i>Needle</i> for passing the thread round the vessel.—§ 165, pl. XXIII, fig. 158.             |   |
| 64. Thread of different degrees of thickness.  |   |
| 64a. Bull's-nose forceps for stopping vessels.—§ 165, pl. XXIII, fig. 149.                         |   |

*For Making Opaque Injections.*

## NECESSARY.

65. *Size or gelatine*.—§ 167.  
 66. *Vermilion*.—§ 169.  
 67. *Bichromate of potash and acetate of lead* for making solutions for precipitating yellow *chromate of lead*.—§ 170.  
 68. *Carbonate of soda and acetate of lead* for making solutions for precipitating *carbonate of lead*.—§ 171.

## ADVANTAGEOUS.

*Injecting can*, made of copper.—§ 166, pl. XXIII, fig. 152.

*For Making Transparent Injections.*

69. *Ferrocyanide of potassium*. “*Muriated tincture of iron*,” *Glycerine and Spirits of wine* for preparing the *Prussian blue injecting fluid*.—§ 178.  
*Carmine*.—§ 180.

**XIII.—Of Staining Tissues.**

70. *Carmine fluid* for colouring the germinal matter of tissues.—§ 199.

**XIV.—Chemical Analysis in Microscopical Investigation.**

71. *Platinum foil*. *Small platinum capsule*.  
 72. *Test tubes and rack*.—Pl. XLV, fig. 282.  
 73. *Small tubes* about an inch or an inch and a half in length. *Small flasks*.  
*Platinum wire*.  
 74. *Stirring rods*.  
 75. *Evaporating basins*.—Pl. XIV, fig. 73.  
*Watch glasses*.—§ 85.  
 76. *Small glass bottles with capillary orifices*.—§ 307, pl. XLV, figs. 278, 280, 281.  
 77. *Wire triangles, tripods*.—§ 71, pl. XIV, figs. 71, 72.  
 78. *Small retort stand*.—§ 70, pl. XIV, fig. 69.

**Reagents :—**

79. *Alcohol*.—§ 289.  
 80. *Ether. Chloroform*.—§ 290.  
 81. *Nitric acid*.—§ 292.  
 82. *Sulphuric acid*.—§ 293.  
 83. *Acetic acid*.—§ 295.

84. *Hydrochloric acid.*—§ 294.
85. *Ammonia.*—§ 300.
86. *Solution of potash.*—§ 298.
87. *Solution of soda.*—§ 299.
88. *Nitrate of silver.*—§ 303.
89. *Nitrate of barytes.*—§ 302.
90. *Oxalate of ammonia.*—§ 304.
91. *Iodine solution.*—§ 305.
92. *Test papers.*

**XV.—Cabinet for Preserving Microscopical Specimens.**

93. *Drawers* arranged so that the specimens may be *perfectly flat.*—§ 274.
  94. *Boxes with trays* for containing specimens, p. 274.
-

## NAMES AND ADDRESSES.

### BRITISH MICROSCOPE MAKERS.

<p>Baker, 244, High Holborn, London.          Browning, 111, Minorities, E.C. (Spectrum Apparatus).          Bryson, Princes-street, Edinburgh.          Collins, Charles, 77, Great Titchfield-street, Oxford-street.          Crouch, H. and W. 64A, Bishopsgate Within, E.C.          Dancer, 43, Cross-street, Manchester.          Field, Birmingham.          Highley, S., 18, Green-street, Leicester-square, London.</p>	<p>King, Bristol.          Ladd, W., 12, Beak-street, Regent-st., London.          Murray and Heath, 69, Jermyn-street, London.          Parkes and Son, St. Mary's-row, Birmingham.          Pillscher, 88, New Bond-street, London.          Powell and Lealand, 170, Euston-road, London.          Ross, 53, Wigmore-street, London, W.          Salmon, 85, Fenchurch-street, London.          Beck and Beck, 31, Cornhill, London. E.C.</p>
--	--

### FOREIGN MICROSCOPE MAKERS.

<p>Amici, Modena.          Bénéche, Berlin, Tempelhofer Strasse, 7.          Brunner, Paris.          Chevalier, Paris.          Hartnack and Oberhäuser, Place Dauphine 21, Paris.          Hasert, B., Eisenach.          Kellner, Wetzlar.</p>	<p>Merz, G. and S., Munich.          Mirand, A., senr., Paris.          Nachet, Rue St. Severin 17, Paris.          Ploesl, S., Vienna.          Schröder, Hamburg, Holländischer Brook, 31.          Schiek, F. W., Berlin, Halle'sche Str., 15.          Zeis, C., Jena.</p>
---	--

Most of the microscope makers furnish cabinets and boxes for objects, apparatus, and instruments required by the microscopist.

### MAKERS OF CUTTING AND OTHER INSTRUMENTS REQUIRED BY MICROSCOPISTS.

<p>Matthews, Portugal-street, Lincoln's-inn.          Weedon, Hart-street, Bloomsbury.</p>	<p>Weiss and Sons, 62, Strand.</p>
--	------------------------------------

### PREPARERS OF MICROSCOPIC OBJECTS.

<p>Barnett, J. E., Whitehall-street, Tottenham.          Hett, A., Reigate.          Hudson and Sons, Greenwich.          Norman, J., 178, City-road, London, E.C.</p>	<p>Topping, C.M., 11, Loader's-terrace, Manor-road, Bermondsey.          Wheeler, E., 48, Tollington-road, N.</p>
--	---

Collections of objects of various kinds may also be obtained of almost all the microscope makers.

### MATERIALS AND APPARATUS FOR MOUNTING OBJECTS.

<p>Claudet and Houghton, 89, High Holborn (for thin glass, glass cells, &amp;c.).          Crouch, 64, Bishopsgate-street Within.          Griffin and Co., Long-acre, London.          Highley, 18, Green-street, Leicester-sq., London.</p>	<p>King, G., 190, Portland-street, W.          Matthews, Portugal-st., Lincoln's-inn, London.          Beck and Beck, Cornhill, London.          Norman, 178, City-road, London, E.C.</p>
---	---

### LIVE AND DEAD ANIMALS may be obtained of

Davis, T., 72, Anthony-street, Commercial-road East.

### ARTISTS. DRAUGHTSMEN.

<p>Aldous, Mr., W. Lens, 47, Liverpool-st., King's Cross.          Burgess, Mr. Edwin, 52, Cumming-st., Pentonville.</p>	<p>West, Tuffen, Mr. W. West, Hatton-garden.</p>
--	--

### WOOD ENGRAVERS.

<p>Hart, Mr., 33A, Red Lion-square, E.C.          Malden, Mr., Hart-street, Bloomsbury.</p>	<p>Powell, Miss, 170, Euston-road, N.W.          Ruffle, Mr., 17, Princes-road, Kennington.</p>
---	---

### PRINTERS. LITHOGRAPHIC AND PHOTOGRAPHIC PRINTERS.

<p>Adlard, 22, Bartholomew-close.          Blanchard and Sons, Millbank-street.          Brooks, V., Lithographic Printer, Photographic Lithography, 1, Chandos-street, Covent-garden.</p>	<p>Harrison and Sons, St. Martins'-lane.          Sedgfield, R., Norbiton, Photographic Printer.          Toovey, Photographic Lithographer.          West, W., Hatton-garden, E.C.</p>
--	---

### LITHOGRAPHIC STONES—DIAMONDS FOR ENGRAVING, AND OTHER APPARATUS USED IN LITHOGRAPHY.

<p>Hughes and Kimber, West Harding-street, E.C.</p>	<p>Stoer Brothers, Vulcan Wharf, 14, Earl-street, Blackfriars, London.</p>
---	--

### APPARATUS FOR DRAWING, ENGRAVING, &c.

<p>Brodie and Middleton, 79, Long-acre.</p>	<p>Rowney, G., 52, Rathbone-place.</p>
---	--

WORKS ON THE MICROSCOPE, NATURAL HISTORY, &c.,  
USEFUL TO THE STUDENT.

THE MICROSCOPE.

The Microscope and its Revelations. Dr. W. B. Carpenter, F.R.S.  
John Churchill and Sons. 1868.

The Microscope. Prof. Quekett. Baillière. 1852.

The Microscope ; its History, Construction, and Teachings. Jabez  
Hogg.

The Microscope in Vegetable Physiology. Schacht.

The Microscope. Hannover, translated.

The Microscope. Dr. Lardner.

The Microscope. Dr. Wythes.

Manual of Human Microscopic Anatomy. Prof. Kölliker. Trans-  
lation by Dr. Chance.

Histology, Vegetable and Animal Structures. Quekett.

The Microscope in its Application to Clinical Medicine, Dr.  
Lionel Beale, F.R.S. 1867. Churchill and Sons.

The Microscopic Anatomy of the Human Body in Health and  
Disease. A. H. Hassall, M.D.

On the Structure and Growth of Tissues. Dr. Lionel Beale, F.R.S.  
1861. Churchill and Sons.

Text Book of the Microscope. Dr. Griffith, F.L.S. 1864. John  
Van Voorst.

Text Book of Objects for the Microscope. J. Lane Clarke.  
Groombridge and Sons.

The Preparation and Mounting of Microscopic Objects. Thomas  
Davies. Robert Hardwicke.

Micrographic Dictionary. Griffith and Henfrey.

Microscopic Teachings. The Hon. Mrs. Ward. Groombridge.

Half-hours with the Microscope. Dr. Lankester, F.R.S.

Evenings at the Microscope. P. H. Gosse, F.R.S.

NATURAL HISTORY.

Zoology, by Van der Hoeven, translated by Rev. W. Clarke.  
Of value for classification and the description of typical forms.

Comparative Anatomy of Vertebrata, by Owen. 1866.

- Odontology, by Owen. Two vols. 1845.  
 On the Skeleton, by Owen. 1848.  
 Animal Kingdom, by Rymer Jones. 1855.  
 The Animal Creation, by Rymer Jones, 1865. Society for Promoting Christian Knowledge.  
 Natural History of the European Seas, by Edward Forbes. 1859.  
 Chart of the distribution of Marine Life, by Edward Forbes. One of the maps in Keith Johnston's Physical Atlas, but sold separately.  
 British Reptiles. Bell, Thos. 1839.  
 British Fishes. Yarrel, Wm. Two vols. 1836.  
 Mollusca, by Woodward, S. P. 1856.  
 Nudibranchiate Mollusca, by Alder and Hancock. 1854.  
 Medusæ, by Edward Forbes. Pub. by Roy. Society.  
 Oceanic Hydrozoa, by Huxley. 1859.  
 Actinologia Britannica, by Gosse, P. H. London. 1860.  
 British Zoophytes, by Johnston, Geo. 1838.  
 British Starfishes and Echinodermata, by Edward Forbes. 1841.  
 Cirripedia. Darwin, Chas. 1854.  
 British Crustacea. Bell, Thos. 1853.  
 Entomostraca. Baird, W., M.D. 1850.  
 Spiders. Blackwell, John. 1861.  
 Introduction to Entomology. Westwood. Two vols. 1860.  
 On Parasites. Denny, Henry. 1842.  
 Entozoa. Cobbold, S. 1864.  
 A Manual of the Sub-kingdom Protozoa. J. R. Greene, B.A. Longman, 1863.  
 Coelenterata. J. R. Greene, B.A. Longman, 1863.  
 On Sponges, by Bowerbank and Johnston. 1864.  
 On Foraminifera. Williamson and Carpenter. 1862.

## WORKS ON COLLECTING.—THE AQUARIUM, ETC.

- The Collector's Handy-book of algæ, diatoms, desmids, fungi, lichens, mosses, &c. Translated and edited by the Revd. W. W. Spicer, M.A. Robert Hardwicke.  
 Manual of British Marine Zoology. Gosse. Two volumes, with 678 illustrations. A most useful epitome.  
 The Aquarium. Gosse.  
 Devonshire Coast. Gosse.  
 Tenby, P. H. Gosse. Land and Sea. Gosse. Nisbet and Co.  
 Seaside Book. Harvey.  
 Seaside Studies. G. H. Lewes.  
 Marvels of Pond Life. H. J. Slack. Groombridge and Sons.

Butterfly Vivarium. Noel Humphreys.

The Common Objects of the Microscope. The Rev. J. G. Wood. Routledge and Co.

The Common Objects of the Country. The Rev. J. G. Wood. Routledge and Co.

The Common Objects of the Sea Shore. The Rev. J. G. Wood. Routledge and Co.

The Aquarium, of Marine and Freshwater Animals and Plants. G. B. Sowerby, F.R.S. Routledge and Co.

ON BOTANY, DESMIDIÆ, DIATOMACEÆ, &C.

Botany, by Prof. Balfour. Edinburgh.

Botany, by Prof. Bentley. Churchill and Sons.

A History of Infusoria, including the Desmidiæ and Diatomaceæ, by Andrew Pritchard. Fourth edition. Whittaker.

Botanical Microscopy, by Schacht. Translated by Currie.

Desmidiæ. Ralphs. British Diatomaceæ. Smith.

British Freshwater Algæ. Hassall.

British Marine Algæ. Harvey.

British Seaweeds. With Notices on some of the Freshwater Algæ. The Rev. D. Landsborough. Routledge and Co.

Microscopic Fungi. Cooke. Cryptogamiæ. Hofmeister.

British Mosses. Wilson. British Lichens. Landers.

British Ferns. Newman.

Observations on Fossil Vegetables. Lond. and Edinb. 1831.

The Internal Structure of Fossil Vegetables. Wittham, Henry. Lond. and Edinb. 1833.

WORKS AND MEMOIRS ON PHOTOGRAPHY AS APPLIED TO  
THE MICROSCOPE.

Trans. Mic. Soc. Lond., in Quart. Jour. Mic. Science, Ap. 1853. Papers by Delves, Shadbolt, Highley.

Ditto, July, 1853. Binocular Vision. Wheatstone.

Ditto, Oct. 1853. Ditto. Wenham.

Quart. Journ. M. S., No. vii, 1854, p. 202. Developing Solution and Artificial Light. G. B.

Ditto, No. viii, p. 290. Match Photographs. Riddell.

Quart. Journ., M. S., No. x, Jan. 1865 (Trans. Mic. Soc. Lond.) Photographs of Mic. Objects. Wenham.

Encyclopædia Britannica. Art. Microscope, 1857. Brewster.

Liverp. and Manch. Phot. Journ. 1858, No. 15. Delineation of Mic. Objects. Traer.

The Photographic Journ., No. 87, Feb. 1, 1859. Delineation Mic. Objects—Artificial Light. Legg.



The Brit. Journ. Photo., No. 15, Nov. 1861. Practical Application of Photography to the Microscope. Rood, N. Y.

Ditto, No. 160, Feb. 15, 1862. Photomicrography. Parry.

Ditto, No. 163, Ap. 1, 1862. Microscopic Photography. Neyt.

Photographic Times, Ap. 15, 1862. Neyt. The Brit. Journ. Photo., No. 165, May 1, 1862. On Photomicrography. Bockett.

Quart. Journ. Mic. Science (Oct. 1862). Microscopic Stereography. Smith. Die Photographie als Hulfsm. mikrosk. Fors. J. Gerlach, 1863. Atlas der allgem. Thier. Geweb. nach d. Nat. Photo. Hessling und Kollmann. Ditto, Jan. 1863. On the Photographic Delineation of Microscopic Objects. Maddox.

The Brit. Journ. Photogr., No. 175, Oct. 1, 1862. Delineation Mic. Objects by Photography. Maddox. Ditto, No. 182, Jan. 15, 1863. Photomicrography applied to Educational purposes. Highley. Ditto, No. 183, Feb. 2, 1863. Ditto. Ditto, No. 185, Mar. 2, 1863. Ditto. Ditto, No. 187, Ap. 1, 1863. Ditto. Ditto, No. 197, September 1, 1863. Photomicrographic Camera. Eden. Highley. Ditto, No. 213, May 2, 1864. Photomicrography, Weightman. Ditto, No. 216, July 1, 1864. Magnesium Light applied to Photomicrography, Maddox.

Quart. Journ. Mic. Science, 1863 and 1864. Photographs of Mic. Objects by Polar. Light. Thos. Davies.

Photography, Orr's Circle of the Sciences, by Sparling, and Lond., Ed., and Dub. Philos. Mag., June, 1863. Kingsley's Arrangement for Ox. Hy. Gas Camera Lantern.

A review in the Med. Chir. Review, July 1, 1864.

The Photographic Journ., No. 152, Dec. 15, 1864. Photomicrography. Maddox. Quart. Journ. Microscopical Science, No. XX. Mar., 1865. Photomicrography, its application and results. Maddox.

Quart. Journ. Microscopical Science, July, 1865. Monochromatic Illumination. Count Castracane.

Ditto. Correspondence, July, 1866. Photomicrography with high powers. Dr. J. J. Woodward, Washington, U. S.

Brit. Journ. Photog., Aug. 4, 1865. Bockett's Photomicrography with a landscape lens.

La Photographie appliquée aux recherches Micrographiques. Par A. Moitessier, M.D. Paris, 1866. Ballière et Fils.

Dr. Wilson's Photomicrography, Popular Science Review, Nov. 22, 1866.

The Philadelphia Photographer, No. 33, 1866; Photomicrography. Dr. J. J. Woodward.

Microscopic Photography, Brit. Journ. Photography, Feb. 1, 1867, The Rev. St. Vincent Beechy.

Rouget's Memoir at the Acad. des Sciences, on the Photographs of Microscopic appearances of various tissues—some as stereographs. 1867.

Brit. Ass. Sect. D. S. Highley on the application of Photography and the magic lantern, to Microscopic and Natural History. Class demonstrations.

#### JOURNALS, PERIODICALS.

Quarterly Journal of Science, edited by J. Samuelson and W. Crookes, F.R.S. John Churchill and Sons.

Quarterly Journal of Microscopical Science, edited by Dr. Lankester, F.R.S., and George Busk, F.R.S. John Churchill and Sons.

Popular Science Review, edited by Prof. Henry Lawson, M.D. Hardwicke.

Archives of Medicine, edited by Dr. Lionel Beale, F.R.S. John Churchill and Sons.

Intellectual Observer. Monthly. Groombridge and Sons.

Science Gossip. Monthly, 4*d*. Hardwicke.

Land and Water. Edited by F. Buckland. Weekly.

The Naturalists' Note Book. Monthly, 4*d*.

#### FOREIGN BOOKS.

Das Mikroskop. P. Harting and Dr. F. W. Theile. Vieweg and Sohn. 1867.

Das Mikroskop und die Mikroskopische Technik. Dr. Heinrich Frey. 1863.

Das Mikroskop, Theorie und Anwendung desselben. Carl Nägeli und S. Schwendener.

Einleitung in die Technische Mikroskopie. Julius Wiesner. 1867.

Das Mikroskop. Paul Reinsch. Nürnberg. 1867.

Das Mikroskop und seine Anwendung. Dr. Leopold Dippel. Braunschweig. 1867.

Beiträge zur Neuern Mikroskopie. Fried. Reinicke. 1862.

Gewebelehre. Gerlach.

Lehrbuch der Histologie. Leydig.

Du Microscope et des Injections. Robin. 1849.

Observateur au Microscope. Dujardin. 1842.

Max. Schülze's Archiv. Bonn.

Kölliker und Siebold. Zeitschrift.

Reichert und Du Bois-Reymond Archiv.

# INDEX.

---

- ABERCROMBIE, DR.**, his mode of illumination for photographing microscopic objects, 247  
 Aberration, spherical and chromatic, 6  
 Absorption bands, measuring the position of, 225  
     "          "          varieties of, in spectrum analysis, 221  
 Acari, examination of, 155  
 Acetic acid, 203  
     "          "          syrup, 296  
 Acid carmine injecting fluid, 95  
     "          "          chromic, 57  
     "          "          in glycerine, 297  
 Acids, effects of, on organic structures, 203  
     "          "          and corrosive fluids, microscope for examining substances immersed in, 201  
 Action of cells, 320  
     "          "          of the heart, 135  
 Adipose tissue, 119  
 Adjustments for altering the focus, 8  
 Advantages of using transparent injections, 90  
 Air bubbles, microscopical appearance of, 70  
 Air cells of lung, epithelium in, 136  
 Alcohol, 202  
     "          "          and ether, effects of, 202  
 Alkalies, effects of, on organic structures, 205  
 Altering power of cells, 311  
 Alum, preservative solution, 58  
 Amœbeæ, 170  
     "          "          movements of, 313, 325  
 Ammonia, phosphate, testing for, 210  
 Anacharis, circulation in the cells of, 165  
 Analyser and polariser, 18  
 Analysis, chemical, in microscopical investigations, 197  
     "          "          microscopical, new method, 211  
 Anatomical peculiarities of tissues, of demonstrating, 116  
 Anchusa paniculata, circulation in the cells of, 165  
 Angle of aperture, 7  
 Anilin colours for staining tissues, 110  
 Animalcule cage, 66  
 Animal substances, separating crystals from, 213  
 Annular reflector, 21  
 Aperture, angle of, 7  
 Apology for the use of very high magnifying powers, 280  
 Apparatus, chemical, necessary for microscopical observer, 201  
     "          "          necessary with a student's microscope, 17  
     "          "          necessary list of, 356  
 Appendix, 340  
 Aquaria, 151  
 Areolar tissue, 118  
     "          "          submucous examination of, 131  
 Arsenious acid, solution for preserving in, 59  
 Arseniuretted hydrogen gas for preserving animal substances, 59  
 Arteries, examination of, 126  
 Artificial and natural injections, 87  
     "          "          illumination, 19  
 Artists, 363  
 Ascertaining the diameter of objects, 38  
     "          "          magnifying power of object glasses, 37  
**BAILEY, MR. J. W.**, his universal indicator for registering the position of various objects on a slide, 42  
**BAKER, MR.**, his travelling microscope, 13  
**BARKER, DR. JOHN**, his growing stage, 67  
 Barytes, nitrate of, 206  
 Basement membrane of kidney, 142  
 Beginners, first steps in the examination of objects in the microscope, 71  
**BECK, MR.**, his parabolic reflector, 21  
**BELL'S** cement, 48  
 Bibliography, 364  
 Bichromate of potash, glycerine solution of, 297  
 Binocular microscope, Mr. Collins's, 11  
     "          "          Messrs. Powell & Lealand's, 12  
     "          "          Mr. Tolles' arrangement, 12  
     "          "          Mr. Wenham's arrangement, 11  
 Black paper placed behind transparent specimens examined by reflected light, 21

- Blood, circulation of, 134  
 ,, corpuscles, examination of, 133  
 ,, spectrum of, 222
- Blowpipe beads, examination, in the spectrum microscope, 223
- Blue colours for staining tissues, 111  
 ,, injecting fluid, Turnbull's, 94  
 ,, ,, ,, advantages of employing, 92  
 ,, Prussian, new form of, 97
- Body of the microscope, 9
- Bone, dry, of making thin sections, 82  
 ,, examination of, 121
- Books, lists of, 364
- Boric acid, its use in preparing specimens, 340
- Bottles, dropping, for glycerine, 301  
 ,, test, with capillary orifices, 209
- Brain, examination of, 143
- Branched muscular fibre, 123
- Branchiæ of mollusca, 159
- BRIDGMAN, MR., his instrument for drawing circles upon the thin glass cover of a specimen, 41
- BROOKE, MR., his mode of perforating thin glass, 63
- BROWNING, MR., spectrum eye piece, 219  
 ,, ,, of albuminous fluid, 341
- BRÜCKE, PROF., on the use of boric acid, 340
- Brunswick black cement, 48  
 ,, ,, cells made of, 60
- Brass plate for heating upon, 43
- Built glass cells, 64
- Bull's eye condenser, 21
- BURNET'S solution, 58
- Cabinet, keeping preparations in, 186
- Camera for taking photographs of microscopic objects, 235  
 ,, applied to the microscope, 241  
 ,, lucida, 27
- Camphine lamp, 20
- Canada balsam, 50  
 ,, ,, alteration of delicate tissues in, 105  
 ,, ,, of examining specimens in, 76
- Cans for holding injection, 88
- Capillaries, examination of, 126
- Capillary orifice, test bottles with, 209
- Carbonate of lead, 89  
 ,, lime, appearances, examined in different media, 69  
 ,, ,, testing for, 210
- Carmine fluid for staining germinal matter of tissues, 108  
 ,, injecting fluid, 94  
 ,, ,, ,, Dr. Carter's, 96  
 ,, ,, ,, Thiersch's, 110
- CARTER, DR., carmine injection, 96
- Cartilage, 120
- CASTRACANE, COUNT, on microscopical photography, 23
- Cavities of crystals, 177
- Cells, 311  
 ,, action of, 320  
 ,, Brunswick black, 60  
 ,, built glass, 64  
 ,, contents, 317  
 ,, deep glass, 63  
 ,, false, 319  
 ,, growing, 66  
 ,, gutta-percha and ebonite, 65  
 ,, marine glue, 61  
 ,, moulded glass, 65  
 ,, of plants, circulation in, 165  
 ,, paper for dry objects, 60  
 ,, shell-lac, 60  
 ,, thin glass, 62  
 ,, tin foil, 60  
 ,, wall, 318
- Cement for attaching gutta-percha and India-rubber to glass, 49  
 ,, French, for mounting large preparations, 52
- Cementing glass together, 62
- Cements, 48
- Centres, new, of living matter, 317
- CHANCE, MESSRS., manufacturers of thinnest glass, 286
- Chara, circulation in the cells of, 165
- Chemical analysis in microscopical investigations, 197  
 ,, apparatus in microscopical observations, 201  
 ,, solutions, hardening properties, 216
- Chloride of calcium, preservative solution, 58  
 ,, gold for colouring nerves, 113  
 ,, zinc preservative solution, 58
- Chlorides, testing for, 210
- Chromate of lead, 89
- Chromatic aberration, 6
- Chromic acid, solution of, in glycerine, 297
- Colouring matter for opaque injection, 89  
 ,, ,, transparent injection, 91
- Colours, injecting different opaque into different systems of vessels, 90
- Common salt preservative solution, 58
- Compound microscope, 4
- Compressorium, 81
- Condenser, achromatic, 24  
 ,, bull's eye, 21  
 ,, Gillett's, 24  
 ,, Webster, 25
- Concave metallic reflector, 21
- Conical glasses, 84
- Contractility of muscle, 160
- Conversion of germinal matter into formed material, 313

- Conversion of standards of measurement, 39
- COOK, MR. C. W., his micrographic camera, 28
- Cord, spinal, examination of, 144
- Corks, loaded, 79
- Cornea, terminal plexuses of nerves in, 128
- Correcting object glasses, 6
- "    "    "    "    Mr. Wenham's improvement, 8
- Creosote and naphtha preservative solution, 56
- Crystallisation, influence of various constituents upon, 212
- "    "    "    "    spiral, 214
- Chromic acid, 203
- Chyle, movements of, 133
- Ciliary movement, 161
- Ciliated epithelium, 161
- Circle, Mr. Bridgman's instrument for marking upon the thin glass cover, for the purpose of marking the position of an object, 41
- Circulation in the cells of certain plants, 165
- "    "    "    "    of the blood, 134
- CLARKE, MR. J. LOCKHART, his method of preparing the spinal cord and brain, 144
- Class microscope, 14
- Cleaning off superfluous glue, when cell-making, 62
- Clinical microscope, 14
- Coal, preparing for microscopical examination, 185
- Cobweb micrometer, 35
- COHNHEIM, PROF., his mode of colouring nerves, 113
- Collecting and dredging, 146
- COLLINS, MR., his binocular microscope, 11
- "    "    "    "    Bockett lamp, 20
- "    "    "    "    new graduating diaphragm, 10
- Colouring nerve fibres, solution of chloride of gold for, 113
- "    "    "    "    germinal matter of tissues, 157
- "    "    "    "    matter, size of the particles used for injections, 90
- Crystals, anatomy of, 174
- "    "    "    "    examination of, under the microscope, 215
- "    "    "    "    cavities in, 177
- "    "    "    "    formation of, 211
- "    "    "    "    making sections of, 179
- "    "    "    "    obtaining, for examination, 213
- "    "    "    "    of one mineral enclosed in another, 177
- "    "    "    "    preservation of, as permanent objects, 215
- "    "    "    "    separation of, from animal substances, 213
- Cutting and grinding glass, 61
- "    "    "    "    sections of tissue under the microscope, 80
- DANCER, MR., his speculum illuminator for opaque objects, 22
- Dark bordered nerve fibres, examination of, 127
- "    "    "    "    ground illumination, 22
- Deep glass cells, 63
- Delineating objects, 26
- Demodex folliculorum, 155
- Demonstrating anatomical peculiarities of tissues, 176
- "    "    "    "    microscopes, octagon and square boxes for mounting several in, 16
- "    "    "    "    minute structure by highest powers, 291
- Deposit, examination of, 86
- "    "    "    "    removing with the pipette, 85
- "    "    "    "    separating the coarse from the finer particles, 85
- "    "    "    "    when very small in quantity, 85
- Diameter of objects, of ascertaining, 38
- Diaphragm, 9, 24
- "    "    "    "    Mr. Collins's graduating, 10
- "    "    "    "    Mr. Kincaid's mode of altering the aperture, 9
- Diatoms, collecting and mounting, 167
- Disk, steel, 27
- Dissecting binocular microscope, 17
- "    "    "    "    microscope, 13
- "    "    "    "    tissues under the microscope with the aid of the compressorium, 81
- Dissections, minute, of making, 78
- Distilled water, 201
- Distribution of nerves to skin of the mouse's ear, 128
- Double bladed or Valentin's knife, 45
- "    "    "    "    edged scalpels, 44
- Drag hook for sea collecting, 149
- Draughtsmen, 363
- Draw, importance of being able to, 26
- Drawing, apparatus and instruments for, 363
- "    "    "    "    objects magnified by highest powers, 288
- "    "    "    "    on stone, 30
- "    "    "    "    pencils, 29
- Drawings microscopical, importance of appending scales of measurement to, 34
- "    "    "    "    of obtaining lithographs of, 29
- "    "    "    "    making which it is intended should be engraved, 28
- Drilling holes in glass, 61
- Dropping bottles, 301
- Dry bone, of making thin sections, 82
- Drying and evaporating, 200
- Dry tissues, of cutting thin sections, 82
- Dry way, of permanently preserving specimens in the, 75

- Ducts of glands, injecting, 101  
 ,, the liver, injecting, 140
- Ebonite, cells made of, 65
- EDWARDS, M. MILNE, his plan of injecting the snail, 103
- Effects of acids on organic structures, 203  
 ,, alcohol and ether ,, 202
- Egg capsule of insects, markings upon, 158
- Embryonic tissues, preparation of, 307
- Engravers on wood, 363
- Engraving, of making drawings for, 28  
 ,, on stone, 30
- Epithelium, ciliated, 161  
 ,, examination of, 131  
 ,, in the air cells of the lung, 136
- Errors of observation, 192
- Ether, 202
- Evaporating and drying, 200
- Examination of a deposit, 86  
 ,, soft tissue, general directions, 117
- Extraneous matters, 195
- Eye of the ox, plan of injecting, 99
- Eye piece, Hugenian, 5  
 ,, Kelner's, 5  
 ,, micrometer, 35  
 ,, negative and positive, 5
- Fact hunting, 188
- False cells, 319  
 ,, generalizations, 187
- Fallacies to be guarded against in microscopical investigations, 191
- Fibres and membranes, production of, artificially, 193
- Fibrillæ of muscle, 124
- Fibrous tissue, white, 119  
 ,, ,, yellow, 119
- Field, flatness of, in the microscope, 6
- Fiftieth of an inch object-glass, 285
- Filtering, 200
- Finder, Mr. Bailey's, 42  
 ,, Mr. Bridgman's, 43  
 ,, Mr. Maltwood's, 42
- Finding the same spot in a specimen, method of, 41
- Fine nerve fibres, 331  
 ,, ,, as test objects, 36
- Fishes, injecting of, 104
- Fixing solutions in photography, 274
- Fluids, of examining substances in, 75  
 ,, separating deposits from, 84
- Focus, adjustments for altering, 8
- Folding microscope of Messrs. Powell and Lealand, 11
- Foreign standards of measurement, of converting, 39
- Formation, new views on, 308
- French cement for mounting large microscopical preparations, 52
- FRERE, DR., his plan of drilling holes in thin glass, 63
- Frog, plan of injecting the, 99
- Frog's foot, circulation of the blood in, 134
- Ganglia, examination of, 146  
 ,, of Hyla, preparing for highest powers, 301
- Gas lamp, Mr. Highley's, 20
- Gelatine preservative, 57  
 ,, and glycerine, 57
- Generalization, on, 308
- GERLACH, PROF., his method of staining tissues, 108
- Germinal matter, 312  
 ,, ,, of colouring, 107  
 ,, ,, movements of, 170
- GILLETT, MR., his condenser, 24
- Glands, injecting the ducts of, 101  
 ,, salivary, &c., examination of, 137
- Glandular epithelium, 132  
 ,, organs, more easily demonstrated in the lower animals than in man and the higher animals, 141
- Glass cells, deep, 63  
 ,, cementing pieces together, 62  
 ,, cutting and grinding, 61  
 ,, drilling holes in, 61  
 ,, shades, 47  
 ,, slides, plate, 46  
 ,, thin for covering specimens, 47
- Glycerine, 54  
 ,, action of, on tissues, 292  
 ,, bottles for dropping, 301  
 ,, as the basis of preservative fluids and test solutions, 296
- GOADBY'S preservative solution, 58
- Gold size cement, 48  
 ,, solution of chloride, for colouring nerve fibres, 113
- GORHAM, MR., his apparatus for pressing down the thin glass cover of specimens, 51
- Graduating diaphragms, 10
- Grammatophora subtilissima, as a test object, 36
- Granules within cells, movements of, 172
- Green injecting fluid, 96
- Grinding glass, 61
- Growing cells, 66
- Growth, new views on, 308  
 ,, and multiplication, 173
- Gum and glycerine, preservative medium, 58
- Hair and horn, sections of, 83
- Hairs, examination of, 158
- Handling bodies under the microscope, 80
- Hard tissues, examination of, 82  
 ,, ,, with highest powers, 305
- Hardening properties of different chemical solutions, 216  
 ,, tissue, 82
- HARTNACH, M., his immersion glasses, 6

- Heart, action of, 135  
 ,, examination of muscular structure of, 125
- Heat, use of, in rendering specimens clear, 302  
 ,, stimulus to life, 316
- Heating objects while under microscopical examination, Dr. Ransom's plan, 157  
 ,, ,, Max Schultze's plan, 157
- Hemispherical condenser, 24
- Hepatic vein, injecting, 139
- HIGHLEY, MR., his collecting case, 147  
 ,, ,, gas lamp, 20  
 ,, ,, travelling microscope, 13  
 ,, ,, waistcoat pocket microscope, 16
- High powers made with single front, 6
- Highest magnifying powers, 284  
 ,, ,, ,, conditions of using, 291  
 ,, ,, ,, of drawing objects magnified by, 287  
 ,, ,, ,, new method of preparing soft tissues, 290  
 ,, ,, ,, hard tissues, 304
- HOBLYN, MR., his arrangement for exerting pressure upon the thin glass covers of specimens, 51
- Horn and hair, making sections of, 83
- How to examine an object under the microscope, 71
- Hughenian eye-piece, its construction, 5
- Hyalodiscus subtilis, as a test object, 36
- Hydrochloric acid, 203
- Hyla, injecting and examining with highest powers, 299
- Illuminating objects in the microscope, methods of, 17
- Illumination, artificial, 19  
 ,, Mr. Dancer's speculum, 22  
 ,, dark ground, 22  
 ,, modes of, for photographing microscopical object, 247  
 ,, monochromatic, 23  
 ,, of objects magnified by very high powers, 287
- Image of objects, method of increasing, 287
- "Immersion" glasses, 6  
 ,, twenty-fifth, 285
- Indicator, Mr. J. W. Bailey's, 42
- Inferences, drawing of, from observations, 188
- Inflammation, 315
- Infusoria, examination of, 154
- Injected preparations, preparing portions of, for microscopical examination, 104
- Injecting, best modes of destroying the lives of animals for, 106  
 ,, cans, 88
- Injecting carmine and Prussian blue, 303  
 ,, different systems of vessels with transparent injection, 97  
 ,, ducts of glands, 101  
 ,, fishes, 104  
 ,, fluid, acid carmine, 95  
 ,, ,, blue, Turnbull's, 94  
 ,, ,, carmine, 94  
 ,, ,, Dr. Carter's, 96  
 ,, ,, green, 96  
 ,, ,, Prussian blue, 93  
 ,, ,, yellow, 96  
 ,, frog, 99  
 ,, insects, 103  
 ,, liver, 99, 139  
 ,, lymphatic vessels, 102  
 ,, mollusca, 103  
 ,, ox eye, 99  
 ,, practical operation of, 98  
 ,, rat, 99  
 ,, sheep's kidney, 99  
 ,, tissues for examination by highest powers, 295
- Injections, instruments required in making, 87  
 ,, mercurial, 70  
 ,, mounted in Canada balsam, alteration in the appearance, 105  
 ,, natural and artificial, 87  
 ,, opaque, 88  
 ,, pressure requisite in making, 100  
 ,, transparent, 90  
 ,, ,, colouring matters for, 91
- Ink, lithographic, 31
- Insects, injecting of, 103  
 ,, preparing the tissues of, for microscopical examination, 158
- Instrument makers, 363
- Instruments required in making injections, 87
- Intercellular substance, 313
- Involuntary muscular fibres, 122
- Iodine solution, 207
- Iron and steel, microscopical structure of, 181
- Irritation, 315
- ISEBELL, REV. G., his arrangement for pressing down the thin glass cover, 51
- JACKSON'S eye-piece micrometer, 35
- KELNER'S eye-piece as a condenser, 24
- Keeping preparations in cabinets, 186
- Kidney, basement membrane of, 142  
 ,, matrix of, 142  
 ,, sheep's, mode of injecting, 99  
 ,, vessels of, 142
- KILBURN, MR. W. E., on introducing a jet of oxygen into paraffine lamp, 288
- KINCAID, MR., on altering the size of the aperture in diaphragm, 9
- KING, MR., his vivarium microscope, 13

- Knife, section, new form, 44  
 ,, Valentin's, 45
- Lacteals, examination, 132
- LADD, MR., his chain adjustment for altering the focus, 8
- Lamplight, shade for protecting the eyes from, 20
- Lamp, Mr. Collins's Bockett, 20  
 ,, gas, Mr. Highley's, 20  
 ,, paraffine with round wick, 20  
 ,, Smith and Beck's camphine, 20  
 ,, spirit, 43
- Large microscopes, 10
- LAWSON, DR., his binocular dissecting microscope, 17  
 ,, INSPECTOR-GENERAL, his section knife, 44
- Lead, carbonate of, 89  
 ,, chromate of, 89
- Lieberkuhn, 21
- Life, 323  
 ,, and death, 329
- Light, arranging, in drawing with the camera lucida, 27  
 ,, polarised, 18  
 ,, reflected, 18  
 ,, transmitted, 18
- Lilac colouring fluid, Thiersch's, 110
- LISTER, MR., his improvements in making microscopes, 4
- Lists of books, 364
- Lithographic ink, 31
- Lithographer's stones, 31
- Lithographs of microscopical drawings, of obtaining, 29
- Lithography, apparatus required in, 363
- Liver, demonstrating the structure of, 138  
 ,, general examination of, 138  
 ,, injecting the ducts of, 140  
 ,, making an injection of, 99
- Living matter, 312  
 ,, ,, properties of, 311
- Loaded corks, 79
- Lobules of the liver, 139
- Lower animals, examination of, during life, 154
- Lung, 136
- Lymphatic vessels, of injecting, 102
- Madder, staining the bones of living animals with, 121
- MADDOX, DR., his camera for taking photographs of microscopic objects, 244  
 ,, his plan of photographing without a camera, 241  
 ,, on photography, 232  
 ,, spring clip, 52
- Magic lantern, photographs of microscopic objects for, 276
- Magnifying power of object glasses, of ascertaining, 37  
 ,, ,, tests for defining, 36
- Magnifying powers, very high, 284  
 ,, ,, apology for using, 280
- Makers of microscopes, 363
- MALTWOOD, MR., his finder, 42
- Manipulation, microscopical importance of, 1
- Marine glue, 49  
 ,, ,, cells, 61
- Marking the position of an object, 41
- Matrix of kidney, 142
- Matters of extraneous origin, 195
- Measuring objects, simple method of, 37  
 ,, thin glass, instrument for, 286
- Measurement, standards of, 39
- Medium in which tissues should be placed, 74
- Membranes and fibres, production of, by re-agents artificially, 193
- Mercurial injections, 98
- MERZ, M., his immersion glasses, 6
- Metallic reflector, 21
- Methylated alcohol, 54
- Micrographic camera, 28
- Micrometer cobweb, 35
- Microscope, binocular, 11  
 ,, ,, dissecting, Dr. Lawson's, 17  
 ,, body of, 9  
 ,, camera applied to, 241  
 ,, clinical, 14  
 ,, dissecting, 13  
 ,, folding, Messrs. Powell and Lealand's, 11  
 ,, for examining substances immersed in acids, 287  
 ,, large, 10  
 ,, makers, 363  
 ,, spectrum, 218  
 ,, students', 10  
 ,, ,, apparatus necessary for, 17  
 ,, travelling, Mr. Warrington's, 13
- Microscopical analysis, new method of, 211  
 ,, examination, preparing portions of injected tissues for, 104  
 ,, investigation, chemical analysis in, 197  
 ,, manipulation, 1
- Microscopic shells, 159
- Minute dissections, of making, 78
- Mirror, 8
- Moist, keeping bodies, while under microscopical examination, 156
- MOITESSIER, DR., his method for photographing opaque objects, 247
- Molecular movements, 172
- Mollusca, injecting, 103
- Monochromatic illumination, 23
- Moulded glass cells, 65
- Mounting objects, 363  
 ,, photographs, 274



- Mounting, apparatus for, 363  
 Movements, ciliary, 161  
 „ „ molecular, 172  
 „ „ of granules within cells, 172  
 „ „ primary or vital, occurring in living beings, 170  
 Moving in all directions, 170  
 Mucous membrane, 131  
 Mucus corpuscle, 170  
 Multiplication and growth, 173  
 Muscle, contractility of, 160  
 Muscular fibre, examination of, 122  
 „ „ fibres of villi, 132  
 „ „ structure of heart and tongue, 125  
 Naphtha and creosote fluid, 56  
 Natural and artificial injections, 87  
 Naturalist's dredge, 149  
 Needles in handles, 45  
 Nerve, examination of, 127  
 „ „ fibres, solution of chloride of gold for staining, 113  
 „ „ ganglia, examination of, 146  
 Neutral tint glass reflector, 27  
 Newt's kidney, examination of, 141  
 NEYT, M., his method of illumination for photographing microscopic objects, 250  
 NICHOL's prism, 18  
 Nitella, circulation in the cells of, 165  
 Nitrate of silver, staining solutions, 112  
 Nitric acid, 202  
 NOBERT, M., his test lines for definition of the magnifying power of object glasses, 36  
 Nuclei, 317  
 Nutrition of the cell, 320  
 Object-glasses, 5  
 „ „ „ angle of aperture, 36  
 „ „ „ ascertaining magnifying power of, 37  
 „ „ „ Mr. Wales's improvements in, 6  
 „ „ „ fiftieth and twenty-fifth, 285  
 „ „ „ penetrating power of, 7  
 „ „ „ their own illuminators, 21  
 Objects, delineation of, 26  
 „ „ examining by different modes of illumination, 25  
 „ „ „ microscopical, simple method of measuring, 37  
 Observation, drawing inferences from, 188  
 „ „ errors of, 192  
 Observations, of making, upon specimens in the microscope, 187  
 Octagonal and square cases for holding and fixing several demonstrating microscopes, 16  
 Oil, examining specimens in, 76  
 „ „ globules, microscopical appearances, 70  
 Opaque injections, 88  
 Operation of injection, 98  
 OSBORNE, REV. LORD S. G., process of staining followed by, 108  
 Osmic acid, solution of, 113  
 Pancreas, examination of, 137  
 Paper, black, for placing behind transparent objects, 21  
 „ „ cells made of, 60  
 „ „ tracing and retracing, 29  
 Paraffine lamps, 20  
 Particles of colouring matters, used as injections, the sizes of, 90  
 „ „ of living matter, 312  
 PASTEUR, M., his investigation on minute organisms, 282  
 Peculiarities of texture, of representing, 31  
 Pencils, for drawing, 29  
 Penetrating power of object-glasses, 7  
 Perforating thin glass, 63  
 Pewter plate for glass grinding, 61  
 Phosphate of ammonia, testing for, 210  
 „ „ lime, 210  
 Photographing of microscopic objects, 229  
 „ „ „ apparatus for, 235  
 „ „ „ focussing, 254  
 „ „ „ illumination, 235  
 „ „ „ Maddox, Dr., his camera, and plans of procedure for, 241  
 „ „ „ „ his arrangements for working without a camera, 244  
 „ „ „ „ object-glasses, 254  
 „ „ „ „ Woodward, Dr., his method of, 237  
 Photographs, of microscopic objects, fixing solutions, 274  
 „ „ „ for magic lantern, 276  
 „ „ „ mounting the prints, 274  
 „ „ „ toning solutions, 273  
 „ „ „ stereoscopic, 256  
 Photography, list of books on, 366  
 Pinning out dissections upon tablets, 79  
 Pipettes, 84  
 „ „ of removing deposits from fluids with, 85  
 Plants, of the circulation in the cells of certain, 165  
 Plate glass slides, 46  
 Plexuses of nerves in the cornea, examination of, 128  
 Podura scale as a test object, 36  
 Polarised light, 18  
 „ „ „ uses of, 175

- Polariser and analyser, 18  
 Pollen grains, examination of, 164  
 Portal vein, 139  
 Position of an object, marking the, 41  
 Potash, solution of, 205  
 „ and soda, solutions of, in glycerine, 297  
 POUCHET, M., investigations upon minute organisms, 282  
 POWELL and LEALAND, MESSRS., their binocular microscope, 12  
 „ „ „ „ folding microscope, 11  
 „ „ „ „ highest powers, 284  
 Powers, magnifying, 5, 280  
 Precautions to be observed in working at the microscope, 73  
 Preservation of crystals, as permanent objects, 215  
 „ „ soft tissues, general directions, 117  
 Preparers of microscopic objects, 363  
 Preparations, keeping them in cabinets, 186  
 Preserving specimens in glycerine, 54  
 „ „ Canada balsam, 76  
 „ „ the dry, 75  
 „ „ vegetable tissues permanently, 167  
 Preservative fluids, 53  
 Pressing down the thin glass covers of specimens while cement is drying, arrangements for, 51  
 Pressure required in making an injection, 100  
 PRICE'S glycerine, 55  
 Primary or vital movements occurring in living beings, 170  
 Primordial utricle, 317  
 Prints, photographic, mounting, 274  
 Printers, 363  
 Properties, hardening, of different chemical solutions, 216  
 „ of living matter, 311  
 Protoplasm, 310  
 Prussian blue, advantages of employing, 92  
 „ „ the injecting fluid, 93  
 „ „ new form of, 97  
 QUEKETT, PROF., his achromatic condenser, 24  
 RAMSDEN'S positive eye-piece, 5  
 RANSOM, DR., method of applying heat and cold to objects, while under microscopic examination, 157  
 Rat, mode of injecting, 99  
 Razor for cutting thin sections, 45  
 READE, REV. J. B., his hemispherical condenser, 24  
 Reaction of substances, 199  
 Re-agents, production of membranes and fibres by, artificially, 193  
 Re-agents used in microscopical investigations, 201  
 Acetic acid, 203  
 Alcohol, 202  
 Ammonia, 205  
 Chromic acid, 203  
 Distilled water, 201  
 Ether, chloroform, 202  
 Hydrochloric acid, 203  
 Iodine solutions, 207  
 Nitrate of barytes, 206  
 „ „ silver, 207  
 Nitric acid, 202  
 Oxalate of ammonia, 207  
 Potash, solutions of, 205  
 Soda, solutions of, 205  
 Sulphuric acid, 202  
 „ „ uses of, 198  
 Recording results of microscopical observations, 190  
 Reflected light, 18  
 Reflector, annular, 21  
 „ „ concave, metallic, 21  
 „ „ neutral tint, 27  
 „ „ parabolic, 21  
 Removing deposits with the pipette, 85  
 Results of microscopical observations, of recording, 190  
 Reviewing, medical and scientific, 312  
 Retort stands, 43  
 Rings to diminish the size of the aperture over water bath, 44  
 ROBERTSON, DR., his table for conversion of British and foreign lineal measurements, 39  
 „ „ MR., his plan of injecting the snail, 104  
 Rocks and crystals and fossils, examination of, 174  
 „ „ „ „ making sections, 179  
 ROSS, MR., his improvements in the compound microscope, 4  
 Round cells, 66  
 RUTHERFORD, MR. L. W., his microscopical photographs, 23  
 Salivary glands, examination, 137  
 Sarcolemma of muscular fibre, 123  
 Scale, importance of appending to drawings of microscopical objects, 34  
 Scales, examination, 158  
 Scalpels, 44  
 SCHULTZE, MAX, his iodine solution, 208  
 „ „ stage for heating objects, 157  
 Scissors, for minute dissections, 45  
 Sea dredging, 146  
 Sealing-wax varnish, 48  
 Secondary movements occurring in living beings, 172  
 Section knife, 44  
 Sections, cutting under the microscope, 80  
 „ „ thin, obtaining of, 80

- Seeds, external markings of, 164  
 Seeing what is described, importance of, 3  
 Spherical aberration, 6  
 Selenite, 19  
 Separating crystals from animal substances, 213  
 ,, deposits from fluids, 84  
 ,, ,, ,, when very small in quantity, 85  
 ,, the coarse from the finer particles of a deposit, 85  
 Serous and synovial membranes, 130  
 SHADBOLT, MR., annular condenser, 23  
 ,, turn-table for making circular cells, 60  
 Shade for protecting the eyes from the glare of strong light, 20  
 Shades, glass, for protecting objects from dust, 47  
 Shell-lac cells, 60  
 ,, cement, 48  
 Shells, microscopic, 159  
 SHEPARD, MR., on colour produced by living organisms, 340  
 Silver, nitrate of, 207  
 ,, ,, for staining tissues, 112  
 Simple microscope, 4  
 Size for injection, 88  
 ,, of particles of colouring matter used for injections, 90  
 ,, of objects, apparent, under different powers, 286  
 Sketches, importance of making, 184  
 SLACK, MR., his diaphragm eye-piece, 289  
 Slides of plate glass, 46  
 SMITH, MR. JAS., his leaf holder, 46  
 SMITH, PROF., his growing cell, 66  
 ,, ,, mechanical finger, 81  
 ,, PROF. LAWRENCE, his plan of making the object-glass its own illuminator, 21  
 Snake, action of the heart in, 135  
 Soda, solutions of, 205  
 Soft tissues, general directions for examining and preserving, 117  
 Soluble Prussian blue, new form, 97  
 Solution of Canada balsam, 51  
 SORBY, H. C., F.R.S., on spectrum analysis, 218  
 Sorting tray, for sea collecting, 149  
 Specimens, of examining and preserving in the dry, 75  
 ,, new methods of preparing, for examination with highest powers, 290  
 Spectrum analysis, 218  
 ,, microscope, 218  
 ,, ,, examining objects in, 221  
 Spinal cord, examination of, 144  
 Spiral crystallization, 214  
 Spirit lamp, 43  
 Spot glass, 22  
 Spring clips, 52  
 Stage, 7  
 Stage micrometer, 35  
 Staining bones of living animals with madder, 121  
 ,, germinal matter of tissues, 107  
 ,, tissues, 106  
 ,, ,, blue colours for, 111  
 ,, ,, Gerlach's method, 108  
 ,, ,, Lord Osborne's process, 108  
 ,, ,, nitrate of silver solutions for, 112  
 Standards of measurement, 39  
 Starch globules enclosed in cells, 164  
 Steel and iron, microscopical structure of, 181  
 Stereoscopic photographs, 256  
 Stimulus, 329  
 Stomach, mucous membrane of, 132  
 Stone, drawing on, 30  
 ,, engraving on, 30  
 ,, grinding glass on, 61  
 Stones, lithographic, 31  
 Stops, 21  
 Striped muscle, 122  
 Structure, general observations on, 114  
 ,, muscular, of heart and tongue, 125  
 ,, new views on, 308  
 Structures, difficulty of seeing, from their transparency, 193  
 Students' microscopes, 10  
 Submucous areolar tissue, examination of, 131  
 Substances of extraneous origin, 195  
 ,, in fluids, examination of, 75  
 Sulphates, testing for, 210  
 Sulphuric acid, 202  
 Sunlight illumination, 19  
 Surface net for sea collecting, 149  
 Synovial membranes, examination of, 130  
 Syrup, action of, on tissues, 293  
 ,, acetic acid, 296  
 Tables for practising manipulation, 347  
 Tablets for pinning out dissections upon, 79  
 Tannin, 111  
 Teeth, making sections of, 83  
 Terminal plexuses of nerves, 128  
 Test bottles with capillary orifices, 209  
 Tests, method of applying, to substances intended for microscopical examination, 208  
 Texture, representing peculiarities of, 31  
 TIHERSCH'S carmine fluid, 110  
 ,, lilac fluid, 110  
 ,, yellow injecting fluid, 96  
 Thin glass, 47  
 ,, of perforating, 63  
 ,, instrument for measuring thickness of, 286  
 ,, sections of dry bone, making of, 82  
 ,, ,, of textures, obtaining for microscopical examination, 80

- THOMAS, MR. R., on spiral crystallisation, 214
- THWAITES' fluid, 55
- Tin-foil cells, 61
- Tissue, adipose, 119
- " areolar, 118
- " embryonic, preparation of, 307
- " hardening of, 82
- " white fibrous, 119
- " yellow fibrous, 119
- Tissues, colouring of, by osmic acid, 113
- " demonstrating the anatomical peculiarities of, 116
- " of insects, preparing for microscopical examination, 158
- " soft, general directions for examining and preserving, 117
- "    " preparing for examination with highest powers, 298
- " staining of, 106
- "    " by chloride of gold, 113
- "    " vegetable, examination of, 163
- "    " preserving permanently, 167
- TOLLES, MR., his new binocular microscope, 12
- Tongue, examination of muscular structure of, 125
- Toning solutions, 273
- Tracheæ, examination of, 159
- Tracing paper, 29
- Transmitted light, 18
- Transforming powers of cell, 311
- Transparent injections, 90
- "    " colouring matters for, 91
- "    " injecting different systems of vessels with, 97
- Travelling microscope, 13
- Tripods, 43
- Troughs for examining zoophytes in, 66
- Tubes, capillary, 209
- TURNBULL'S blue injecting fluid, 94
- Turpentine, examining specimens in, 76
- Twenty-fifth of an inch object-glass, 285
- Unstriped muscular fibre, 122
- Valentin's knife, 45
- Vallisneria, circulation in cells of, 165
- Vegetable tissues, examination of, 163
- "    " preserving permanently, 167
- Veins, examination of, 126
- Vermilion, 89
- Vessels, injecting different systems with opaque injection, 90
- Vessels, injecting different systems with transparent injection, 97
- "    " lymphatics, injecting of, 102
- Villi, examination of, 132
- Viscid media, advantages of, for dissection of the tissues for highest powers, 294
- Vital movements occurring in living beings, 170
- Vivaria, 151
- Vivarium microscope, 13
- Voluntary muscle, 122
- Vorticellæ and rotifers, 155
- Waistcoat-pocket microscope, 16
- WALES, MR., his improvements in making object-glasses, 6
- Wash bottle, 86
- Watch glasses, 47
- Water, objections to, as a medium for examining specimens in, 281
- " bath, 44
- WEBSTER condenser, 25
- WENHAM, MR., his binocular arrangements, 11
- "    " high powers made of single lenses, 6
- "    " mode of correcting object-glasses, 8
- "    " on the circulation in the cells of certain plants, 166
- WEST, TUFFEN, his engravings of microscopical objects, 33
- White fibrous tissue, 119
- WILSON, DR., his mode of illumination for photographing microscopic objects, 247
- Wood and textures of that character, cutting sections, 84
- " blocks, preparing for being drawn upon, 29
- " makers of, 363
- " engravers, 363
- Wooden forceps, 46
- WOODWARD, DR. (U.S.), his method of taking photographs of microscopical objects, 237
- "    " latest arrangement by, 344
- Work table of a microscopist, 185
- Yellow fibrous tissue, 119
- " injecting fluid, 96
- Zoophytes, destroying the life of, best methods, 155
- " trough for examining them in, 66

# INDEX OF ILLUSTRATIONS.

*The Numbers refer to the Figures in the Plates.*

- Aberration, spherical and chromatic, figs. 5, 6
- Absorption bands, 321  
 " " scale for measuring exact position of, 323
- Achromatic condenser, 54
- Adipose tissue, 172  
 " " with areolar tissue, 172
- Air bubbles, 122  
 " pump for removing air from microscopical specimens, 129
- Amœbæ, very minute, 254
- Anacharis, cells of, 248, 249  
 " entire branch of, 245
- Analyser, 58
- Anchusa, spine of, 246
- Animalcule cage, 112
- Artery passing into capillaries, 190  
 " portion of a very small, 189
- Bacteria, 372—377
- BARKER, DR., his growing cell, 111
- BEALE, DR., his class microscope, pl. vii, and fig. 36
- Binocular microscope, Mr. Collins's, 20  
 " " M. Nacet's, 15  
 " " Mr. Tolles' (U.S.)  
 arrangement of prisms and lenses in, 15  
 " " Mr. Wenham's  
 arrangement, 16
- Bird, large flat villi of, 205
- Blood corpuscles, crystallisation of, 213  
 " " frog, changes in the forms of, 262  
 " " human, 212  
 " guinea pig, formation of crystals in blood of, 216
- Bockett microscope lamp, 48
- Bone, thin sections of, 181
- Brass plate for heating glass slides, 68
- Bulb, with capillary orifice for testing, 278
- Bull's eye condenser, 51, 52  
 " nose forceps, 149
- Cabinet, containing requirements for chemical testing, 284
- Camera, adapted to the microscope, 340  
 " arranged by Dr. Maddox, 339  
 " lucida, position of microscope for using, 56  
 " photographic, microscope, Mr. Delves's, 327
- Canada balsam, can for containing, 127
- Cans for heating size, 152
- Capillaries of human lung, 217
- Capillary vessels showing nuclei, 188  
 " with diverticula, 191  
 " " nerve fibres, 192
- Carbonate of lime in different media, 113—117
- Cartilage, cat, at different ages, 175—178
- Cat's hair, 275
- Caudate nerve cell, 395  
 " " diagram to show possible relation to one another, of various circuits, 402
- Cell for examining solutions in by the spectrum microscope, 322
- Cells, glass concave, 104  
 " " large and deep, for opaque injections, 103  
 " " made by grinding out the centre of a piece of plate glass, 105  
 " " small for injections, &c., 101
- Cements, vessel for containing, 88
- Cerebral matter in water, 196  
 " " softened, 195
- Chloride of sodium, crystals, 270
- Cholesterine crystals, 269
- Chromatic aberration, 5
- Ciliated epithelium, 236
- Circle, instrument for scratching, upon the thin glass cover of a specimen, to show the position of an object, 67
- Circulation in branchiæ of Proteus, apparatus for examining, 106
- Class microscope, pl. vii, and fig. 36
- Colouring matters used for injections, comparative sizes of the particles, 159
- COLLINS, MR., his binocular microscope, 20
- Compound glasses of achromatic objective, 7  
 " microscope, explanatory diagrams, 1
- Compressorium, 135, 136
- Condenser, achromatic, 54  
 " bull's eye, 51, 52
- Connective tissue with nuclei, 168
- Corked tubes for keeping prepared tissues in, 144
- Corks for fitting into the injecting pipe, 150

- Cornea, Hyla, networks of fine nerve fibres in, 197
- Cotton fibres, 275
- Crystals of creatine, 305
- "    "    double salt of sulphate of magnesia and sulphate of zinc, 311—318
- "    "    muriate of ammonia, 304
- "    "    sulphate of copper, 306—310
- Dark bordered nerve fibres, distribution to muscle, 193
- "    "    "    division of, 222
- "    "    "    fine, skin of Hyla, 194
- "    "    "    networks of, frog's eye-lid, 378
- "    "    "    with fine fibres, 198
- Deal wood fibres, 276
- Demodex or entozoon from the follicles of the skin, 235
- Deposit, collecting, when very small in quantity, 145, 146
- Diamond, manner of cutting glass with, 92, 94
- Diaphragm, Collins's new graduating, 59
- Diatoms, instruments and apparatus for collecting, 224
- "    shells of rare, 250, 251, 255
- Dissecting microscope, Dr. Lawson's, 41
- "    "    Prof. Quekett's, 38, 39, 40
- Dissections (minute) under water, arrangements for, 133
- Diverticula, capillary vessel, with, 191
- Drag hook, 230
- Drawing and measuring objects, position of the microscope, 56
- Dredge, 228
- Dredging sieves, 229
- Dust particles, 277
- Egg of the common bed bug, 237
- Epiglottis, nerves and capillaries in, 187
- Epithelial cells from the mouth, 203
- "    "    human villus, 204
- "    "    covering of a villus, entire, 207
- Epithelium, arrangement round villus, 210
- "    "    ciliated, 236
- Eye piece, 2
- "    "    for the spectrum microscope, 319
- Fat vesicles, 173
- Feather, portions of, 275
- Fibrillæ of muscle, 185
- Fibrous tissue, formation of, 167
- Field microscope, Mr. Highley's, 226
- Filtering paper, mode of folding, 147
- Finder, Mr. Maltwood's, 65
- Flax fibres, 275
- Forceps, bull's nose, 149
- "    "    for minute dissections, 85
- "    "    which attach to the stage of the microscope, 86
- Formed material, production of, 355—371
- Gall bladder, vessels of, double injection, 161
- Ganglia and connecting bundles of nerve fibres from the small intestine, young bull, 199
- "    "    portions of two, with connecting nerve trunks, 200
- Ganglion cell, with nerve fibres, pericardium, ox, 202
- "    "    straight and spiral fibres, 223
- "    "    cells, a mass of, imperfectly developed, 410
- "    "    portion of, on the side of a sympathetic nerve, 201
- Gas microscope lamp, 49
- GERLACH'S arrangement for obtaining parallel rays, 337
- Glycerine, small bottle for holding, 342
- Grey matter, guinea pig, drawn from Dr. Beale's preparation, 166
- "    "    "    a German specimen, 165
- Growing cell, 111
- Hairs, cat, 275
- "    "    human, 275
- HIGHLEY, MR., his complete microscope, 11, 12
- "    "    "    field microscope, 226
- "    "    "    gas microscope lamp, 49
- Holder, 98
- Hot stage, suggested by Max Schultze, 233
- Hugheman eye piece, 2
- Injecting apparatus, pl. xxiii
- "    "    a piece of intestine, manner of, 164
- "    "    cans, 152
- "    "    syringe, 151
- Intestine, bull, ganglia in connective tissue of, 199
- Inverted microscope, Dr. Smith's, 271
- Kidney, capillaries injected, 163
- Kidneys of the newt, 218
- Knives for cutting thin sections of tissues, 75, 76
- Lacteals of villi, injected, 209
- Lacunæ and canaliculi, frontal bone, frog, 180
- Lamp, Bockett, 48
- "    "    camphine, 46

- Lamp, paraffine, with round wick, 47  
 " spirit, 70  
 LAWSON, DR., his dissecting microscope, 41  
 Leaf, cellular tissue, fibres and spiral vessels of, 242  
 LEESON'S eye-piece, goniometer, 268  
 Lieberkuhn, mode of examining with, by reflected light, 53  
 Liver, capillaries injected with chromate of lead, 162  
 Living matter, growth and multiplication of, 355—370  
 Loaded corks, 134  
 Lung, portion of human, healthy, 217  
 Lymphatics, injected, 160  
 MADDOX, DR., his camera, 339  
 " " spring clip, 90  
 Maggot, muscular fibres of, 381—383  
 Malpighian body and uriniferous tube, newt's kidney, 219  
 MALTWOOD, MR., his finder, 65  
 Microscope, binocular, Collins's, pl. vi  
 " " M. Nachet's, 15  
 " " clinical, Dr. Beale's, pl. vii, and fig. 36  
 " " boxes for holding and fixing them in, 31—34  
 " " dissecting, Prof. Quekett's, 38, 39, 40  
 " " double, M. Nachet's, 14  
 " " field of, 226  
 " " inverted, Dr. Smith's, 271  
 " " Messrs. Powell & Lealand's, 13  
 " " mineralogical, 272  
 " " Mr. Highley's "complete," 11, 12  
 " " Mr. Salmon's "students'," 10  
 " " spectrum, eye-piece of, 319  
 Mildew in various stages of development, 259  
 Milk globules, 124—126  
 Mineralogical microscope, 272  
 Mirror, 19  
 Moist chamber, Recklinghausen's, 232  
 Moth, scales from, 273, 274  
 Mouth, epithelium of, 203  
 Mucus corpuscle, showing alterations in form, 256  
 Muriate of ammonia crystals, 304  
 Muscle, fibrillæ of, 185  
 " " germinal matter, and formed material of, 257  
 " " mylohyoid, Hyla, 379  
 " " unstriped, distribution of nerves to, 388  
 Muscular fibre cells, 186  
 " " and elastic fibres, artery, 171  
 " " fibres, maggot, 381, 383  
 " " mouse's diaphragm, 182  
 Mylohyoid muscle, Hyla, 379  
 " " " distribution of nerves to, 380  
 NACHET, M., his binocular arrangement, 45  
 " " " microscope for enabling two observers to examine an object at one time, 14  
 Needle for passing thread round vessels, 158  
 Needles in handles, 80  
 Negative eye-piece, 2  
 Nerve fibre, division of, dark-bordered, 222  
 " " fibres, networks of fine, in the cornea, 197  
 " " " in frog's eye-lid, 378  
 " " trunks and ganglia, iliac artery, frog, 412  
 Nerves and capillaries, human epiglottis, 187  
 Networks of fine terminal nerve fibres, cornea, 197  
 Neutral tint glass reflector, 60  
 Newt dissected, and kidneys displayed, 218  
 Object-glasses, with high and low angle of aperture, 8  
 Octahedral crystals, in different media, 118—121  
 Octagonal pillar box for holding demonstrating microscopes, 31  
 Oil globules, 123—125  
 Operation of injecting, 154  
 Ovarian ova, stickleback, 345—354  
 Oxy-hydrogen lantern, as arranged by Mr. Highley, 341  
 Papilla of tongue, after Hartmann, 390  
 " " extremities of the muscular fibres in, showing the nuclei, &c., 392  
 " " probable arrangement in, 403  
 Papillæ, compound and simple, tongue, Hyla, 389  
 " " diagram to show arrangement of the nerve fibres in, 403  
 " " supposed arrangement of the nerves at the summits of, 391  
 Parabolic illuminator, 55  
 " " reflector, Mr. Beck's, with Mr. Sorby's flat mirror, 265  
 " " " diagrams to illustrate the different methods of illumination by, 266, 267  
 " " with Mr. Sorby's modification, 50  
 Paraffine lamp, with round wick, 47  
 Perforating thin glass, manner of making thin glass cells, 99  
 Photographic microscope camera, 327  
 Photograph plate holder, 331





- Vallisneria spiralis, cells of, 243  
 " " circulation in, 244  
 " " diagram to show the  
 direction of the currents in, 247  
 Vegetable organisms, with vibrios and  
 fungi, 261  
 Vibratile filaments and minute particles  
 resembling bacteria, human blood, 260  
 Villi injected, small intestine, white  
 mouse, 208  
 " from bird, 205  
 " lacteals injected, 209  
 Villus, epithelial cells of, 204  
 Vivaria and fern case, 227
- Waistcoat-pocket microscope, 37  
 Warming objects under the microscope,  
 apparatus for, 234  
 Wash bottle, 143  
 Water bath, porcelain basins arranged  
 as, 72  
 " with ring to diminish aper-  
 ture, 73, 74
- Water, simple arrangement for conduct-  
 ing, to living bodies under microscopical  
 observation, 111  
 WENHAM, MR., arrangement of prisms  
 and lenses, in his binocular micro-  
 scopes, 16, 44  
 White fibrous tissue, 169  
 Wood (deal) fibres, 276  
 " instrument for cutting sections of,  
 137  
 WOODWARD, DR. (U.S.), his new ar-  
 rangement for taking photographs of  
 microscopical objects, 413-416  
 WRIGHT, MR., his finder, 62
- Yeast fungus in various stages of develop-  
 ment, 253  
 " torulæ, 211  
 Yellow elastic tissue, fibre of, showing  
 the direction in which the germinal  
 matter moves, 258  
 " fibrous tissue, 170









