

SIGILLUM UNIVERSITATIS CALIFORNIENSIS  
MDCCCLXVIII

EX LIBRIS

EDUC. DEPT.

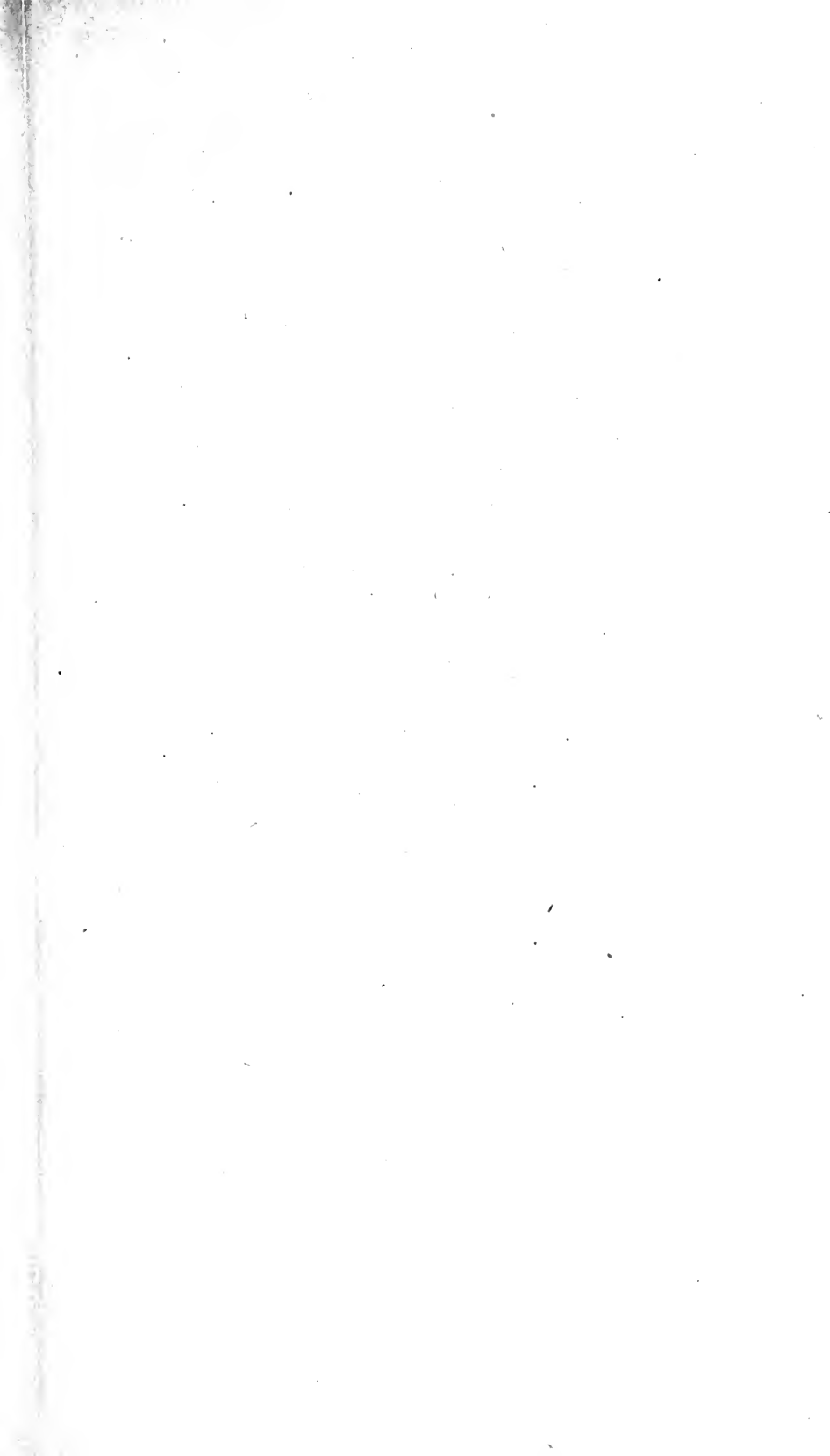



# **HUMAN BEHAVIOR**

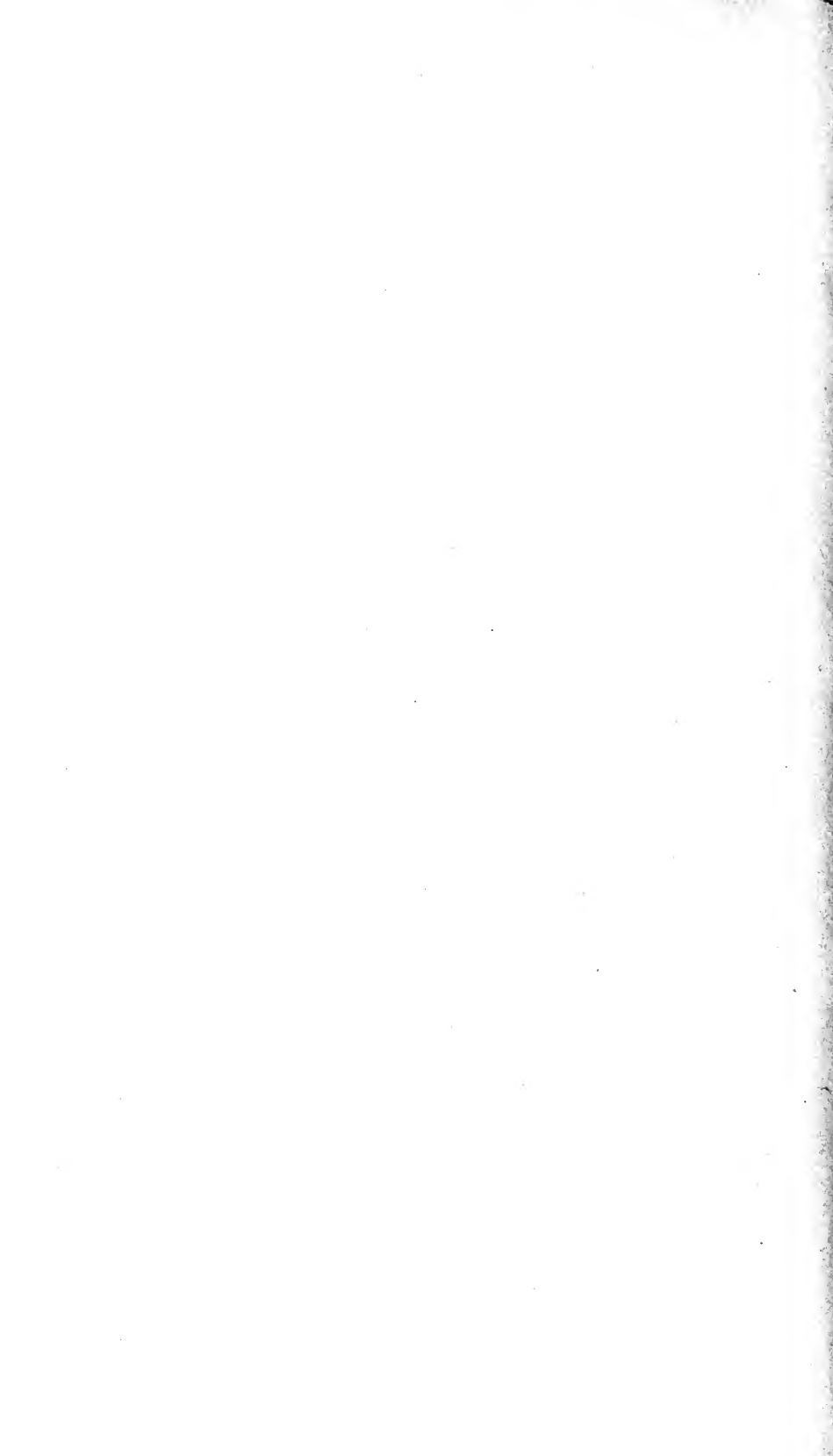

# HUMAN BEHAVIOR

IN RELATION TO THE STUDY OF EDUCATIONAL  
SOCIAL, AND ETHICAL PROBLEMS

BY

STEWART PATON, M.D.

EX-PRESIDENT, EUGENICS RESEARCH ASSOCIATION  
LECTURER IN NEURO-BIOLOGY, PRINCETON UNIVERSITY  
AUTHOR OF TEXT-BOOK ON PSYCHIATRY, AND "EDUCATION  
IN WAR AND PEACE"



NEW YORK  
CHARLES SCRIBNER'S SONS  
1921

7-14-21  
P 3  
2-1-2

COPYRIGHT, 1921, BY  
CHARLES SCRIBNER'S SONS  

---

Published April, 1921

EDUC. DEPT.  
BUREAU OF

NO. 1000  
APRIL 1921

THE SCRIBNER PRESS



## PREFACE

THIS book is intended to serve as an introduction to the study of human behavior. The author has therefore attempted to present a brief outline in a form favorable for discussion and investigation.

The importance of the subject is obvious and has been tragically emphasized by the present world crisis. Little is known about man as he is. Imagination has supplied many of the details in the picture of what he was once supposed to be, while disappointment associated with unrealized expectations of what he might have become has increased the difficulties of taking measure of his present stature. Parent, teacher, physician, student of social phenomena, prospective reformer, statesman, and philosopher, each has his special interest in the great human problem. To-day every intelligent citizen is anxiously awaiting the solution to the problem of how "democracy may be made safe for the world." There can be little doubt that in the careful, painstaking study of man as he is will be found the means by which human institutions may be established upon a more rational basis and at least an intelligent effort made to lay the foundations of a durable peace.

Within a brief preface it would be impossible to give in detail the source of the ideas presented in the following chapters; but the effort has been made to mention names of authors and their works referred to in the text, although doubtless through inadvertence some have been omitted. The aid given me by a few friends in the preparation of the book has been of so unusual a character that I cannot find words in which to express my appreciation of their unselfish and devoted efforts.

Digitized by the Internet Archive  
in 2008 with funding from  
Microsoft Corporation

# CONTENTS

	PAGE
PREFACE . . . . .	V
CHAPTER	
I. THE STUDY OF THE INDIVIDUAL IN RELATION TO EDUCATIONAL AND SOCIAL PROBLEMS . . . . .	1
II. ADJUSTING MECHANISMS . . . . .	26
III. SPECIAL MECHANISMS OF ADJUSTMENT . . . . .	57
IV. THE PERSONALITY . . . . .	94
V. THE DEVELOPMENT OF THE PERSONALITY . . . . .	121
VI. ORGANIZATION AND SYNTHESIS. (TEMPERAMENT, CHARACTER, AND INTELLIGENCE) . . . . .	160
VII. CONTROLLING MECHANISMS. (INHIBITION) . . . . .	213
VIII. FACTORS DETERMINING THE TRENDS OF ACTIVITIES. (DISPOSITIONS) . . . . .	244
IX. HABIT-FORMATION . . . . .	278
X. INVOLUTION OF THE PERSONALITY . . . . .	307
XI. IMPERFECT ORGANIZATION OF ACTIVITIES. (CONFLICT AND DISSOCIATION OF THE PERSONALITY) . . . . .	332
XII. METHODS OF STUDYING THE PERSONALITY . . . . .	369
XIII. THE INTELLIGENT DIRECTION OF ACTIVITIES. (EDUCATION) . . . . .	394
XIV. THE STUDY OF MAN IN RELATION TO THE PROGRESS OF CIVILIZATION . . . . .	440
INDEX . . . . .	455

Our ignorance in regard to the essential problems of living is largely a product of sins of omission. "The great cruelty of the English," according to the entertaining reflections of that keen Swiss student of men, Muralt, who visited England in the seventeenth century, "lies in permitting evil rather than doing it." The good-natured, rich, cruelty-hating nation allowed prisoners in their jails to die of starvation.\* To-day this mental peculiarity of the Anglo-Saxon is shown clearly in the extraordinary expenditure of energy in attempts to make adequate provision for the care of the pauper, criminal, insane, and all those who have not attained a satisfactory adjustment of their lives, rather than in rational effort to add to the knowledge of human activities with a view to their intelligent regulation. The contemplation of the dramatic element in failure has been more absorbingly fascinating for human interest than an expert effort made in the line of prevention. If a small part of the energy now expended in expatiating upon the various forms of human misery and in devising plans for social uplift were directed toward concerted intelligent action to assist in the biological study of individuals, much suffering would be averted. With the naïve simplicity of children, in poetry or prose, in very short or very long stories, in prayer or in sermons, we dwell upon the deplorable plight into which we have fallen, and then stupidly, inconsistently, and stubbornly refrain from taking, except sporadically, any efficient action to improve our lot.

The facts we possess in regard to human nature represent a part of the phenomena we call Nature. In studying them both we pass from the consideration of relatively simple processes, logically and hopefully, to the investigation of those that are more complex. Only after we shall have obtained a definite knowledge of man as an individual shall we be prepared to undertake the consideration of the more involved social relationship expressed in the community, the nation, or the race.

\* Ellis, H., *The Task of Social Hygiene* (Houghton, Mifflin Company, Boston and New York, 1912).

If education is the intelligent direction of individual activities, sociology the study of the mass relationship of these activities, and ethics the wish to direct these activities with the purpose of attaining a higher and nobler form of civilization, then the logical hope of human progress depends upon the intelligence and earnestness which vitalize and sustain our efforts in the attempt to know something more about the nature and genesis of thought and conduct.

This era is one of unrest; a period of becoming. Our system of education is attacked, radical changes in the social order are demanded, adequate substitutes for the traditional forms of religion, which have been weighed in the balance and found wanting, are eagerly sought for. Every day novel schemes for educational reforms and social uplift are proposed only to be rejected as inadequate for the satisfaction of human needs. "Despite our remarkable advance in knowledge," writes McKim,\* "nonsense is ever becoming bolder and more rampant: it is pre-eminently a time of fads and crazes, and the question as to how people are to be brought to their senses grows urgent."

For centuries deductions based upon hypotheses have served as the basis on which the thought and conduct of the human individual have been interpreted. Now the time is approaching when we may hope to know something of the actual conditions under which man lives, moves, and has his being. Not until Galileo, Copernicus, Newton, and other great leaders of modern thought arose was vision given to men, so that they could see and study this world in its relation to the universe. The prejudices that long hindered the study of the physical universe have lingered, and often made man a partisan of coercion in compelling assent to antiquated notions and doctrines in regard to his own activities. Even to-day many students of human conduct maintain that the correct interpretation of the philosophy of Plato, Socrates, or Descartes affords a general formula for right living.

\*McKim, W. Duncan, *A Study for the Times* (G. P. Putnam's Sons, 1920).

"Plato," says M. Duprat,\* "with his aristocratic and Athenian tastes; Aristotle, saturated with intellectualism; Descartes, oscillating between science and religion; Spinoza, a fatalist and mystic—each in turn has described the moral idea according to his own temperament and personal tendencies, and this they have done in almost complete self-absorption, as if assured that all other mortals were fashioned like unto them, and that they themselves were the noblest types of humanity."

Many students approach the problems of living in a state of mind analogous to that of the physicians, who for centuries spent their lives in endeavoring to discover plausible explanations for Galen's views rather than in an attempt to establish a rational basis for medical study founded upon the facts revealed by patient and sagacious investigation. The vagaries of speculative philosophy, too, have unfortunately prevented us from knowing ourselves. Philosophy, absorbed in seeking for ultimate truths, has too often heedlessly—and at times ruthlessly—failed to realize the actual needs of human beings.† Perhaps it may be true that "philosophy has dismounted from her pedestal and become the friend and fellow student of the man in the street." ‡

There is decided need for caution in seeking to determine the genesis of novel and revolutionary ideas; and particularly is this caution requisite in regard to the special subject upon which we are now engaged. All knowledge, at best, is of very slow growth, and conceptions sometimes supposed to have originated within a comparatively short time are found after careful study to possess an ancient lineage. There can be no reasonable doubt that the new biologic method of studying human behavior derived a great stimulus in the nineteenth century from the teachings of Darwin, Spencer, and Mill. The views of these men had profound

\* Duprat, G., *Morals: The Psycho-sociological Basis of Ethics* (The Contemporary Science Series, Scribner, N. Y., 1903).

† Paton, Stewart, *Science*, 1913, N. S., XXXVII, pp. 856-858.

‡ Bradby, M. K., *Psycho-Analysis and Its Place in Life* (Oxford University Press, 1919).

influence upon the subsequent growth of interest in the rational study of human conduct.

Mill went so far as to propose the establishment of a new science for the study of character, which was to receive the name of ethology. But the necessary technique for working out such problems had not then been developed, since it required that the study of physiology itself should advance to a point where it would present a clearer conception of the general mechanisms controlling behavior, especially the functions of the central nervous system. Moreover, it was necessary to wait for the successful formulation of methods of studying the biologic reactions as expressed in behavior, and the consequent clearer ideas as to the nature and structure of the human personality.

There is nothing unusual about the methods already proved successful in solving some of the problems relating to the study of the personality. The main difficulty is to prepare the mind of the observer to undertake these investigations in a spirit free, as far as is humanly possible, from the bias created by opinions formulated so long ago that their age awes us into submissively accepting them without questioning their validity.

In the development of all sciences—and the particular field of knowledge in question is no exception to the rule—there is a general tendency to substitute for vague generalizations definite and specific inquiry in special fields.\* Probably to a greater extent than in any other branch of science this special subject has, until the last century, been largely preempted by those more interested in finding some hook on which to hang a theory than in the actual advancement of knowledge pertaining to the laws governing human thought and conduct. From time immemorial attempts have been made to isolate the processes of acting, feeling, thinking, and reasoning from their intimate relationship and dependence upon other vital functions; and authorities have filled libraries with treatises giving in historical retrospect varying opinions in regard to hypothetical states of mind which

\* Kuelpe, O., *Psychologie u. Medizin* (Engelmann, Leipzig, 1912).

were merely fanciful caricatures of the activities of living beings.

Man too often has been studied as if he were a detachable mechanism in which the parts were put together without any cohesion or unity. Many persons, particularly a certain group of physicians, believe it possible to get an idea of conduct merely by piecing together, as it were, the information obtained from the observation of different organs, just as the functions of the heart have often been studied as if they had no relation to those of the lungs; while the exceptionally complex physiology of the brain is only beginning to be viewed from a standpoint that permits of a discussion of its close dependence upon other bodily activities. Character, as the result of the organismal or synthetic as opposed to the elemental or analytic conception, is now recognized as an integral mentality function,\* and measures the biological capacity for adaptation and harmonious activity.

The elemental line of approach to the human problem received a great stimulus when Vesalius and the other founders of modern biology directed attention to the study of the parts of the living organisms. It was only natural that the attention of investigators should immediately be focussed upon the problems relating to the structure of the human body and its various organs. They believed it to be first necessary to understand the structure of plants and animals in order to interpret their activities correctly. The opposition to the methods of observation based upon the dissection of the body, introduced by those bold pioneers, was even more determined and aggressive than during the controversies waged in recent years about questions relating to personality. The story of Vesalius's early efforts to reconcile what Galen said with the observed facts, carries a lesson which is applicable to many phases of the present inquiries. Having often attempted to reconcile what he had seen with that which the voice of authority had inculcated, he finally became deaf to the latter and believed the testi-

\* Fernald, Guy G., "Character as an Integral Mentality Function," *Mental Hygiene*, 1918, II, no. 3.



mony of his own senses. By this course of action, no less than by his own discoveries, Vesalius gave a lasting impulse to the study of anatomy. In this same century investigators had already shown considerable interest in the functions of the nervous system, and Italian physicians had tried to explore the relation of the muscular sense to the appreciation of weights.

But it was not until modern physiology, under the influence of Johannes Mueller and other leaders, had begun to influence thought that the necessity of studying living organisms as a whole was clearly brought out. Prior to this period the concepts derived from purely anatomical studies had unconsciously led men to believe in a more or less independent unity of the different parts that compose the human body.

One of the greatest debts we owe to modern physiology is for the emphasis it placed upon the relationship between the different organs. In the case of the comparatively simple mechanism of the heart or lungs this intimate union was more easily demonstrated and expressed than in the case of the brain and the nervous system. Special difficulties arose in connection with the study of these latter organs, the most complicated in the human body. A violent opposition was aroused by the efforts made to apply the methods of investigation already proved successful in throwing light upon the functions of other organs to the study of one "imbued with sanctity of reason." Here was a field which probably from man's first appearance upon earth had been supposititiously preempted by speculative thinking.

There have been three important epochs in the study of the brain and nervous system as a mechanism by which the individual activities are expressed. First, there was the period in which the personality with the phenomena of conscious activity was considered as something quite apart and distinct from the underlying mechanism. Then came the time when it was admitted that the brain in a general way was related to the mental activities—a connection that had been hinted at by more than one prophet among the

ancients. The various theories proposed to express this relationship, however, do not concern us at present. Finally, we have come to the modern epoch, in which investigators have awakened to the impossibility of studying the brain as an isolated organ, inasmuch as they now regard it as a part of the adjusting mechanism which brings each individual into contact with his environment.

Claude Bernard exerted a profound influence upon the study of general physiology. He prepared the way for the organismal study of individuals as living units, and directed attention to the fact that many of the phenomena observed in human physiology were identical with those occurring not only in the lower animals but among plants; and this hypothesis served the purpose of making clear the necessity of analyzing vital phenomena from a broader biologic basis. M. Dastre\* has recently said that this physiologist, basing his working hypothesis upon the *contre-pied* of a very ancient doctrine, declared that whereas the blood had long been considered to be the quintessence of the living substance representing the actual vital forces or spirits, it was in reality merely the product of the activity of all "the living particles." By the results of his investigations and by his personal influence, the great master, Bernard, was able to set physiologists free from the constant embarrassment of being compelled to attempt to trace phenomena back to hypothetical "primal causes."

The study of the physiology of separate organs (the elemental analysis) has long been recognized as a legitimate field for observation and analysis, whereas the general collective activities of human beings expressed in the organismal synthesis—feeling, thought, and action—have been deliberately set aside as a subject of thought for those with merely a speculative interest and no practical knowledge of the laws governing human conduct. Here, too, the influence of Bernard in directing the subsequent development of the biological sciences has been incalculable, and to-day those

\* Dastre, M., "Le Centenaire de Claude Bernard," *Soc. d. Biol.*, 16 January, 1914, tome 76, no. 1.

who are interested in the study of human activities owe him a debt of gratitude. Pasteur, writing in 1866 to a friend, referred to the immense influence that Claude Bernard had exercised upon the biological sciences in regard to developing methods of instruction, in quickening progress, and in selecting a scientific phraseology. "*Un esprit nouveau va animer ces belles études.*"

The importance of the lesson to be learned from the establishment of the principle of the organic, as well as fundamental, unity of the individual deserves, on account of its bearing on the problems of behavior, more consideration than it has hitherto received. Many of the errors of the psychologist, especially in the application of his knowledge to educational, social, and ethical problems, may be traced directly to the failure to recognize the impossibility of studying the functions of the brain apart from those of the body as a whole. Probably the forced isolation in which he was once obliged to conduct his investigations, quite apart from other departments of biology, has had an unconscious effect in the formulation of problems to be investigated. But when the individual with all of his activities is studied more or less in perspective, many difficulties, which once seemed to be insuperable, vanish, while other questions appear in an entirely new light in which the relationship of problems of vital importance is clearly discernible.

Some of the remarkable changes incident to the introduction of broader biologic views in man's attitude toward the study of human activities have been summarized by the statement that not only progress in securing the health and happiness of nations but in advancing science, literature, and art may "depend measurably on the cultivation of an intimacy with the family lives of house flies, fleas, and creatures of still more dubious antecedents."\* In the relatively brief periods in life when vision is clearest we perceive the reason why true philosophers admit that the transition from animals to man is not a violent one.†

\* Wilson, E. B., *opus cit.*

† De la Métrie, L. O., *A Leyde*, 1747 (French-English, Open Court Publishing Company, Chicago, 1912).

At present there is also great need for calling attention to the reverse side of the picture: without reinstating man in the position once assumed for him, just a little lower than the angels, we must remember that the extraordinary complexity of the human brain makes it impossible to express all its functions in terms of an ant- or even an ape-psychology.

Special difficulties present themselves in connection with problems relating to the structure and functions of the mechanisms at the basis of human conduct, while others of quite different character are encountered in studying the manifestations of energy as revealed in reflex, automatic, and volitional activities. Those who hope to find the key to human conduct by studying the reactions and behavior of the lower animals are often obliged to put aside the age-old prejudice against any attempt to regard our mental processes as comparable to the responses of other animals. Even before the days of Charron there were those who affirmed there were no breaks in the chain of phenomena, and that from the lowest organisms to man the line of activities in all its various phases was continuous. The author of *De la Sagesse* and his predecessors, who had believed this, although in a less emphatic and definite manner, must, however, be regarded as prophets, since actual proof of the truth of this opinion cannot be said to have then existed. The practical demonstration that the theory was correct was reserved for the modern school of biology, and many facts that led to this result may be attributed largely to the discoveries of American investigators. We now know that there are no specific differences of kind, but only those of degree, between the reflex activities of the protozoa and the highest mental processes of man.\*

It was a significant event in the history of man when Linnæus assigned to the "genus homo" a definite place in the animal kingdom, in the class of mammals and in the order of primates. Not content with this classification he carried the analysis further, and, by taking account of the

\* Jennings, H. S., *The Behavior of the Lower Organisms*, 1906.

higher functions of the brain, groups were recognized within the order.\*

Those who endeavored to study the human being directly were also hampered by the assumption that specific differences were characteristic of the human mind. According to this metaphysical conception, mental aberration or insanity was considered to be a condition essentially different from normal activities. These two misconceptions have had a serious effect, not only in fostering false ideas in regard to the nature of the problems to be solved, but in the selection of methods of investigation. With the acceptance of the belief that our mental faculties differed radically in kind from the reflex and automatic activities of the lower animals and that the symptoms of mental aberration were specifically different from the activities of rational beings, two lines of investigation, along which relatively great progress had already been made in attaining a touchstone of human motives and conduct, were closed.

But to-day there should be little difficulty in convincing intelligent persons that one natural and obvious method of taking up the problems of behavior and conduct is to proceed from the consideration of simpler phenomena as observed low down in the animal series, or from the relatively simple activities of the insane, to the complex functions of the normal person.

This change in the point of attack marks one of the greatest advances in the history of modern science. With but few exceptions all the attempts to gain a clearer knowledge of nervous and mental phenomena had previously been directed to the study of the most complex series of problems as represented by human activities. The childlike simplicity with which we regarded the functional activity of our own brain and attributed to it superior specific qualities sufficient to command for us a unique position in the universe, was the survival of an idea transmitted to us from remote and primitive ancestors. To-day savage races

\* Ritter, W. E., "Science and Organized Civilization," *Scientific Monthly*, 1917, vol. VIII, no. 2.

are interested only in the study of those natural phenomena which directly affect the welfare of the individual, and thus through failure to observe the relationship existing between their own activities and those of other members of the animal kingdom they assume an isolated position depending upon imaginary specific properties supposed not to be possessed by other living creatures.

The acceptance of the idea of evolution was of marked value in determining the attitude of investigators in their approach to the study of the problems connected with human conduct. Nevertheless, even prior to the publication of *Origin of Species*, the way had been prepared for investigating the human individual by methods that were the outgrowth of those employed in other branches of the biological sciences. These were the results of the work of such men as Pinel, Esquirol, and a group of students who were also interested at the beginning of the nineteenth century in the great practical reforms having as their object the amelioration of the care of the insane.

The work of Philippe Pinel has a much wider significance than that generally attributed to it. Vincenzo Chiarugi, assisted by Daquin at Florence (1774-88)\*, had taken measures to ameliorate and improve the methods of treating the insane, but when Pinel removed the chains from the insane in the old hospital of Bicêtre in Paris, he inaugurated a new era, not only in the care of those afflicted with alienation, but also in the study of human behavior. In several passages in his published works this distinguished physician declared that his chief interest in the study of insanity was not directly concerned with the attempt to ameliorate the conditions of a large class of afflicted persons, but by paying close attention to the symptoms that were the result of Nature's method of analysis, he hoped to attain a more comprehensive understanding of human conduct. Some of the theories formulated by Pinel had long been in the air. The French alienist in one of his books states that the in-

\* Pierce, B., "Psychiatry a Hundred Years Ago," *J. Ment. Science*, October, 1919, vol. LXV, no. 27.

fluence by which he was inspired came from John Locke and Voltaire.

It is quite natural that the union of interests and the close proximity of the different fields of investigation should have been recognized by liberal-minded physicians and those great thinkers who, like Locke and Voltaire, have done so much to assist in pointing out the lines of investigation, rich in reward when followed by the earnest seekers of truth. There can be little doubt, says Bailey,\* that Voltaire had a very great influence in stimulating the mental activities of physicians, as well as other workers in biologic and social sciences.† A practical interest in the subject of behavior developed at the time of the French Revolution, just as it has done to-day as a result of the war. The large part the emotions played in shaping the intellectual faculties could not well escape notice, and at every turn there were evidences that the rigid limits once established between sanity and insanity did not exist. There were all grades, but no specific differences of behavior.

Immanuel Kant, in addition to his philosophical work, directed attention to mental problems of a very practical character. As the result of attacks of gout, accompanied by pain and sleepless nights, the philosopher was induced to write down his observations on *The Power of the Mind through Simple Determination to Become Master over Morbid Ideas*. In this pamphlet some suggestions were made that have been incorporated successfully in modern psychotherapy, and the great power of mental impressions in regulating and controlling behavior he very forcibly presented. There is, however, reason to suspect that these ideas were not original with Kant, but were simply a clear statement of impressions based upon personal experience and influ-

\* Bailey, Pearce, "Voltaire's Relation to Medicine," *An. Med. His.*, N. Y., 1917.

† Cabanis, *Traité du physique et du moral de l'homme*, 1802, deserves much credit for his effort to establish physiological psychology on something like a scientific basis. All the higher intellectual processes he conceived to be derived from the primitive sensibility, a common property of all living organisms. He pointed out the correlation between mental activities and physiologic reactions.

enced by currents of thought which in France had already gathered considerable headway. The fact that Kant was not the first person to formulate his impressions about mental phenomena should not detract, however, from the value of his contribution. In his enthusiasm he was led to believe that "gouty troubles, yes, cramps and even epileptic attacks, also podagra, which is described as incurable, can be warded off by a firm determination to distract the attention from them, and little by little they may even be got rid of."\* This idea was taken up and elaborated by Ernst von Feuchtersleben, but in his writings as well as in those of the great philosopher, there is a decided mystical tendency which is not present to the same degree in the works of Pinel and his students.

It is only possible to trace briefly the development of modern psychiatry and dynamic, as distinct from the purely academic psychology, or to show their influence in extending our knowledge of the factors that determine both temperament and character.

Wetterstrand and Liébault prepared the way. Important studies were made relating to the anomalies of temperament and will exhibited in hysteria and other allied disorders; while Charcot, Janet, and others of the French school did much to throw light on the nature of the increased "suggestibility," which not only is such a very prominent feature in psycho-neurotic conditions but also has a very distinct bearing upon the general problem of the analysis of the personality.

The names of Adler, Jung, and Freud are closely associated with the efforts which had been made earlier, particularly in France, to continue to follow the lines of investigation suggested by Pinel—to utilize the experience gained in the observation of abnormal states and to interpret the general laws governing conduct. These principles were abundantly illustrated by the experiences of the war; the intimate connections demonstrated between physical and

\* Bjerre, P., *The History and Practice of Psychoanalysis*, trans. by Elizabeth N. Barrow (Badger, Boston, 1916).



mental strain and the symptoms of shell-shock have brought out many of the important factors to be considered in analyzing the personality.\*

It should not be forgotten that anatomists also had their part in pioneer work in the investigation of conduct. The students of the brain and other organs approached the subject of human behavior from the elemental point of view, and it was only much later, when the biologic sciences developed, that the organismal conception was added.

Franz Joseph Gall (1758-1828), an anatomist and physiologist of repute, called attention to the fact that our general knowledge of conduct must depend upon careful analysis of the laws governing the mental activity in each individual. In spite of the charlatanism which unfortunately characterized Gall's efforts to establish a popular phrenology, his earlier work was scientific and undoubtedly opened up lines of investigation that led to important discoveries. In addition to the suggestion that the functions of the brain might be classed either as "fundamental forces" or "general attributes," he pointed out the similarity existing between the instinctive life of the lower animals and some of the general activities of the human brain; and this suggestion opened a pathway for the psychologist to follow. Gall also showed that an accurate knowledge of personality must depend upon the careful study of the various inherited, as well as acquired, trends which determine individual differences of brain power. Schiller expressed the same idea in the following words:

*"Habe ich des menschen Kern erst untersucht,  
So weis ich auch sein Wollen und sein Handeln."*

It often happens in the history of science that a series of brilliant discoveries in special fields serves temporarily to deflect attention from some of the main problems. Thus, the investigations connected with different parts of the human machine became of more absorbing interest than the

\* *Functional Nerve Disease* (edited by H. Crichton Miller. Oxford University Press, 1920).

study of its general activities. Such was the case when in 1833 Ehrenberg stated as a result of his observations that the "organ of soul," the brain, was made up of countless fine tubes (nerves), and seventeen years later Helmholtz actually succeeded in measuring the rate of transmission of nerve impulse. A Florentine physician, Felix Fontana, in 1781, had seen the nerve cells, but it was not until fifty years later that their significance was appreciated and their structure more fully described by Ehrenberg.

The brilliancy of single discoveries, however, was sufficient to dazzle some investigators, so that they lost sight of the general relationship of the various problems they had been called upon to solve. Unwittingly they developed an uncritical faith in the weapons with which the battle had been fought and forgot that the microscope and other instruments of precision were intended to supplement but not to replace the investigator's own powers of criticism and judgment. The discovery of nerve cells and fibres led a few enthusiasts to become obsessed with the idea that by the study of the structure of the brain alone it would soon be possible to arrive at a rather complete understanding of the mental activities. Still later the active development of biochemistry and the introduction of the concepts and methods of physical chemistry into the study of vital phenomena afforded a second change in the character of the dominant ideas. An attempt was made to express the human activities in terms employed in the chemical and physical laboratories. The most complicated reactions of adjustment of which the human individual is capable were to be expressed in a few simple formulæ. The theories of the laboratory worker, it was hoped and expected, were to be miraculously transformed into actual accomplishments. Many believed that the last link in the chain, which begins with the simplest manifestation of life and ends in the higher mental processes, had been discovered. As is sometimes the case when the scope and fundamental significance of a great problem have not been correctly estimated, the sudden revelation of new difficulties to be met and over-

come brought disappointment to those who had been too sanguine of immediate success.

In the writings of many of the eighteenth-century authors we find evidence that a few men of clear vision had begun to realize that, if the secrets of a man's nature were to be unlocked, it would be by reason, not by theorizing, and by patient, careful study of man himself. The many complex daily problems connected with life were already beginning to impress the leaders of thought with the necessity of establishing guides for human conduct that would be more serviceable than the spectres blown across the vision by the east wind of authority.

More than one independent spirit had already contrasted the immense number of volumes which ornamented the shelves of libraries with the small number of exact observations that had been made upon the subject. The story of the progressive changes in thought that gave birth to these ideas is a part of the history of the development of modern civilization and is a subject far too extensive to be discussed in this volume. We cannot, however, omit a passing reference to Condillac, who had a profound influence upon more than one French physician and founder of modern psychiatry in stressing the necessity for an orderly study of human activities. One passage from his writings is quoted by Pinel\* to prove that analysis and observation are not identical but in reality supplementary processes. "To analyze," said Condillac, "is nothing more nor less than observing the successive qualities of an object in order to give them the exact order in which they occur." If this principle holds for things, why, it was asked, should it not be applied to the elucidation of the laws regulating human behavior?

This idea soon began to influence the work of physicians. The genius of Pinel had forecast the part medical men were bound to take in the development of education. His imagination had already carried him on to face a far greater

\* Philippe Pinel, *Nosographie Philosophique, ou le Méthode de l'analyse appliqué à la Médecine*, 1810, 4me edition, tome I.

task than the immediate relief of the unfortunate insane. He saw in the symptoms of nervous disorders a series of phenomena that established a very close connection between the study "of medicine, history, human endeavor, and moral philosophy." But he realized that before the public would be willing to accept these views it would be necessary to break away from the subjective conceptions of conduct that were no more than mere surmises, colored by the temperament of those who entertained them. The method which Pinel adopted to study the more obvious and coarser derangements of the personality as observed in the insane may be applied, with certain modifications, to working out the subtler problems which present themselves for solution to the student of human nature.

Pinel and the school of observationists had been profoundly influenced by the teachings of Hobbes and Locke, and we have noted Pinel's acknowledgment of the sources of inspiration which led to a revolution, first in the conception of insanity, and then in the actual treatment of those afflicted with alienation. It is only natural that the study of what was obviously abnormal in thought and conduct should have first attracted attention. The acts and thought processes of the insane sometimes stand out in sharp contrast to the activities that are the expression of a well-balanced individual. Often disease, by throwing first one and then another faculty into relief, assists us in following the Ariadnian thread by which we may trace the development of many complicated mental mechanisms and learn to appreciate the existence of an intimate relationship between thought processes which, to the casual examiner, seem to be specifically different. The principle established by Bernard\* was destined to have great influence not only in clearing away obstacles from the path of the physiologist but in bringing about a more comprehensive understanding of the nature of the phenomena concerned in human behavior. "For the savant," said this distinguished scientist,

\* Bernard, Claude, *Introduction à l'Étude de la Médecine Expérimentale*, p. 257 (Paris, 1865).

“neither medicine nor physiology is distinct; there is only one science of life, which must be explained in the pathological state as well as in the physiological.”

In order to analyze and comprehend the laws governing human conduct it is essential that he who proposes to lay down rules of conduct “must be prepared to be a savant before he is a moralist.” Unfortunately the theory is quite frequently voiced that the moralist is capable of arriving intuitively at the knowledge essential for regulating behavior intelligently. Actual practice in the art of getting at the facts conditioning individual effort should be required of those who expect to teach others how to live effectively or happily. Society now has the right to expect and demand that teachers and social reformers should be adepts in the art of living successfully and not mere purveyors of information.

It is a curious fact that the remarkable advance made in the natural sciences during the nineteenth century should have been responsible in a measure for the deplorable ignorance of the phenomena relating to man's own personality. While the intelligent interest and curiosity of investigators has been directed toward the exploration of foreign fields, the unknown field of self-knowledge lay at our very doors. Fascinated by the effort to know something more about the uttermost parts of the universe in which we live, the spell of mystery has often lured us on to attempt to solve problems far removed from the study of our own activities. The rude awakening we are now experiencing in regard to the ignorance of our own natures is one of the tragedies of modern civilization. Gradually, however, and with the naïveté of children, we are beginning to express a desire for knowledge that will assist in solving the problems most intimately related with our daily life. Something more than mere lack of interest has prevented us from knowing ourselves. A peculiar bias, an unfortunate mental attitude, which not infrequently arouses even in the minds of scientific men active antipathy toward an inquiry conducted with a view to determining the laws governing our mental

life, has left us as helpless as mariners at sea without chart or compass.

The problems in reality related to the genesis of human thought and conduct, and not too difficult for immediate solution, have been almost as completely forgotten by the monists as by the dualists. It is unnecessary to recall the interminable list of imaginative hypotheses and vague theories that man's imagination for centuries has invented in the attempt to interpret the genesis and development of the activities of human beings. We believe that the stone dropped from the hand to the earth obeys the law of gravitation. As a matter of fact, we are quite as ignorant of the nature of the law of gravitation as we are of the actual conditions determining the sequence of thought and action; and yet our mental attitude toward the solution of the two sets of problems is, generally, very different. In approaching the former we are free, speaking comparatively, from prejudice and accept the events as they occur; but in the latter instance we are inclined to reject the knowledge that comes to us as the result of experience, because it does not fit in with some philosophical scheme. The same spirit of prejudice which once extracted from Galileo a public denial of the truth, working in a more insidious manner long tried to place obstacles in the pathway of those who were attempting to determine the laws underlying the personality.

In an address delivered at the anniversary meeting of the Imperial Academy, at Vienna, May 30, 1870, Hering said: "So long as the physiologist is content to be a physicist and nothing more—using the word physicist in its widest significance—his position in regard to the organic world is one of extreme but legitimate one-sidedness." In another passage he added: "As long as he remains behind the scenes in the painful exploration of the details of the machinery—as long as he only observes the action of the players from behind the stage—so long will he miss the spirit of the performance, which is, nevertheless, easily caught by one who sees it from the front." \* Here the in-

\* Butler, S., *Unconscious Memory*, p. 65 (Dutton & Company, N. Y., 1911).

terest and significance of the problems of human behavior were fully recognized and a new era in the study of man had dawned.

We have seen how attention primarily was very naturally directed by physicians engaged in the investigation of disease to the various parts of the machine, the functions of first one and then another organ being examined, until finally the mechanism of adjustment itself—the nervous system that controlled by initiating, inhibiting, and modifying the reciprocal activities of organs—became the object of special inquiry.

This is not the place to give even a brief resumé of the contributions made during the past century to the anatomy and physiology of the nervous system. Inspired, but often not assisted directly by this knowledge of neural structure and function, efforts were made to study with ever increasing accuracy the synthesized activities of human beings as expressed in behavior. But even to-day a comparatively small group of investigators realize how extremely subtle and indissoluble are the relations between the various functions of organs as represented, without a suggestion of manifoldness, in the reactions of every living person. When once the principle was recognized that human behavior was a synthesis, and therefore something more than the mere sum of the functions of all parts of the body, then it was possible to lay the foundations not only for the scientific interpretation of the phenomena of nervous and mental disorders but for actual progress in attacking the problems relating to the laws governing normal behavior and conduct. It has taken men centuries to appreciate that an excellent analysis of the mechanisms concerned in human speech, thought, and act is made by Nature, whenever the abnormal complexities of response are simplified by the incidence of defect or by the progress of disease. The result obtained from clinical investigation also has been supplemented by data obtained from experiments upon animals. Although the habits of mind acquired in the laboratory have been chiefly responsible for the introduction of methods of study-

ing the personality in a manner that has led to gratifying results, this line of approach did not open the eyes of investigators to the necessity of studying, in addition to the parts, the behavior of the machine. While the phenomena were observed under varying conditions, this branch of science was still too young to be able to furnish the information essential for a correct explanation of the mental traits, temperament, or character. This much, however, was accomplished: thoughts, words, and deeds were analyzed and described empirically without any direct reference to the "causes." The biologic reactions of human beings were studied and recorded without reference to far-fetched explanations, or to the demands of those who felt constrained to see in every isolated fact the proof of some theory of conduct.

Investigators began to realize how valuable is the knowledge gathered from the actual study of human beings, and this experience made many persons less eager to assume responsibility for the control of activities concerning which little was known. We shall have occasion repeatedly to emphasize the fact that the higher forms of adjustments in the level of the so-called conscious processes are synthesized products, biologic reactions of the entire machine, and that often all that can be attempted at the present time is a simple description of the phenomena without any effort directed to establish correlations.\* It should not be forgotten that in the early seventies Hughlings Jackson formulated his conception of the three-level theory of sensori-motor activity, and the ideas then expressed by this investigator have been very fertile, not only in suggesting lines to be followed in the investigation of neurologic problems, but in creating a new and suggestive point of view in describing the phenomena of consciousness.

Hughlings Jackson was also one of the first investigators not only to adopt a broad, biologic point of view in discussing the practical problems connected with the study of

\*Dunlap, K., *Mysticism, Freudianism and Scientific Psychology* (C. V. Mosby Co., St. Louis, 1920).



human behavior, but to show his appreciation of the two supplementary lines of attack, the elemental and organismal. He drew attention to the reciprocal character of the relations existing between the higher and lower centres of the brain and nervous system, and suggested the idea that there were different levels of adjustment. He also affirmed that every case of mental disease, or failure to adjust life in the higher levels, was a "problem of evolution as well as dissolution," the full significance of which thought we are only beginning to esteem.\*

It is impossible at this time even to name the investigators who have noted for us the necessity of exploring the human personality and of laying bare the laws controlling conduct. But every student of human nature owes a debt to William James for his impressive demonstration of the extent of the field for investigation, for study of the relations of emotional and mental functions to conduct; and also for his exposition of some of the unhappy results that follow man's failure to take an intelligent and active interest in acquiring self-knowledge.

The increasing complexity of our social, economic, and intellectual life has made it essential that our accepted rules for rendering life efficient and happy should have something more to commend them than the dicta of those who are more eager to establish the infallibility of some particular system than to assist in the promotion of human efficiency and happiness. The task is a difficult one. Theories based upon prejudices which have their roots deep in the emotional life of the individual are not easily amended. Our beliefs are all strongly tinged by emotional coloring. Fear and hope, as Goethe has said, may be the greatest enemies of mankind. The sun on the distant peaks, or the shadows in the valleys have often confused man's vision to such an extent that his eyes have failed to note obstacles in his daily path.

Unlimited opportunities for the acquisition of information have been, by tacit assent, mistakenly regarded as afford-

\* Savage, O., *J. Mental Sc.*, 1917, LXVIII, p. 315.

ing a system of education. Those who have passed successfully through the system, having suffered comparatively slight disturbances of equilibrium and retaining the merest traces of intellectual interests and independence, luckily form a large proportion of the so-called educated classes. The countless failures, products of a system by which individuals are either forced by convention or lured by ambition into artificial environments where life becomes strained, hazardous, and often hopeless, are either forgotten or, still worse, are condemned for not having made the best use of present opportunities.

\* Even in practical life, where the highest efficiency attained measures the degree of success, there is no attempt made to estimate the individual's capacity and to assist him with rational advice; he is allowed to go his own way, adopting a hit-or-miss method with an enormous waste of energy, often ending in disaster. We try to aid a person by recommending a line of action suggested by precepts derived from hypotheses, and not by the results of observations based upon experience. We seem, to paraphrase the words of Disraeli, "inebriated with our own verbosity" upon the subject of individualism as opposed to collectivism, but with no very definite idea of the basis and conditions favorable or detrimental to individual activities.

In ethics we establish arbitrary standards, declaring what we think ought to be done, without giving any attention to the determination of whether the struggle to attain an ideal of conduct may not make the later state of a person worse than his original condition. The operation is sometimes pronounced a success, in spite of the intellectual and moral death of the patient.

★ Man is his own worst enemy. Ignorant of his own inner nature, he pursues his course blindly, groping his way. A slave to his natural impulse to indulge in speculation, he resembles, as the poet tells us, a wild animal led in a vicious circle. Midway in his life he often finds himself in the dark forest, with the straightforward pathway lost. Had he known something of himself, had he had an inkling of

the nature and origin of the impulses dominating his real life, had he been capable of appreciating the manner in which the emotional storms gather that often sweep him from his course; had he been trained to be on his guard against the sentimental antipathies that so frequently and insidiously determine his choice of a path leading near or over the brink of a precipice, he might readily have passed through green meadows instead of "the forest, savage, rough, and stern." \*

From the careful, accurate, painstaking study of human beings conducted along broad biologic lines there will be gathered in due time the information leading up to a better understanding of human nature, its hopes, ambitions, and desires; and by following the path of reason we shall discover the causes determining success and failure, peace and war. † ‡ §

The twentieth century promises to be an epoch in which man, after centuries of effort expended in the attempt to extend his limited knowledge of the universe, will take up the study of himself in a spirit of intelligent, active interest, striving earnestly and in a measure successfully, to attain self-knowledge. The truth which will eventually make men free will be the truth revealed by patient, careful study of the human individual; and upon this revelation depend many of the hopes for the continued existence of the human race.

\* Robinson, J. H., "Mind in the Making," *Harper's Magazine*, 1920, No. 844, p. 482.

† Rivers, W. H. R., "Psychology and the War," *Scribner's Magazine*, vol. LXVIII, no. 2, p. 161; also, *Instinct and the Unconscious*, Cambridge Univ. Press, 1920.

‡ Paton, Stewart, "Democracy's Opportunity," *Ment. Hygiene*, 1920, IV, no 4.

§ Bradby, M. K., *Psycho-Analysis and its Place in Life*, Oxford Med. Pub., 1919.

## CHAPTER II

### ADJUSTING MECHANISMS

MANY persons are accustomed to assert that life is a process of adjustment, without pausing to consider the significance of this trite and overworked phrase. They have no actual realization, for example, that the vital processes, including emotional and mental reactions, represent forms of adaptations by which the individual responds more or less perfectly in health and imperfectly in disease to environmental stimuli.

In order to remedy the defect we should begin by maintaining the same spirit of impartial discrimination in discussing all the phenomena of adaptation that characterize the work of investigators in other scientific fields.\* "There is every reason," says Torrey, "to be hopeful that the investigation of biologic problems in the impersonal spirit that has long distinguished the maturer sciences of physics and chemistry will continue to develop a better control and fuller understanding of the processes of living organisms, of which the phenomena of variation in general and of adaptation in particular are but incidental effects." A spirit of this kind will enable us to read a new and broader meaning into what has become a very commonplace phrase.

The capacity of plants or animals to readjust their activities when interfered with is indicative of the regulatory power which harmonizes and unifies all living things. We see, for example, that the various changes in the organism are far from haphazard,† but "proceed in a definite and orderly sequence, resulting in the formation of specific structures and in the performance of definite actions time after

\* Torrey, H. B., "Adaptation as a Process," *Scientif. Month.*, 1919, I, p. 264.

† Ganong, W. F., *The Living Plant* (Am. Nat. Ser., Henry Holt & Co., New York, 1913).

CAMPELL'S CHART. LEVELS AT WHICH MENTAL DISEASES (DISORDERS OF ADJUSTMENT) MAY ARISE

Schema of the Levels of Human Activity.	Types of Mental Disorders.	Important Causal Factors.	Methods of Prevention.
<b>MENTAL AND INSTINCTIVE.</b>	FUNCTIONAL PSYCHOSES and PSYCHONEUROSES, <i>e. g.</i> : Manic-depressive disorders. Various forms of depression. Paranoid conditions. Hysteria. Phobias, obsessions, etc. Dementia præcox.	Causation always complex, not well understood; the following are important causes: <b>HEREDITY.</b> <b>CERTAIN TRAITS OF CHARACTER.</b> <b>FAULTY TRAINING.</b> Poor assimilation of instinctive life.	Extension of education (school and university) to the important problems of the individual life. Co-operation of physicians, psychologists, and teachers necessary for this extension. Special departments in schools and universities to deal with these problems. Clinics, dispensaries, or bureaus of advice to afford early assistance. Cultivation of a frank emotional attitude in general, and of a healthy and open attitude toward sexual matters in particular. (A wide social and educational problem.)
<b>PHYSIOLOGICAL.</b>	Exhaustion psychoses. Senile psychoses. Arteriosclerotic psychoses.	Malnutrition. Overwork. Unhygienic conditions of home or workshop. Constitutional lack of vitality. Stress and strain of life.	Essentially, general hygiene. Hygiene of home and workshop.
<b>BIOCHEMICAL.</b>	Delirium due to fever. Thyroidogenous disorders. Syphilitic brain disease. General paralysis. Tubercular brain disease.	Fever. Disorders of thyroid gland. Syphilis. Tubercle. (Pellagra.)	General preventive medicine. Crusade against syphilis. Crusade against tuberculosis.
<b>CHEMICAL.</b>	Alcoholic psychoses. Drug psychoses. Lead and bisulphide psychoses.	Alcoholism. Drug addiction. Faulty manufacturing.	Crusade against alcoholism and drug addiction. Industrial hygiene.
<b>PHYSICAL.</b>	Traumatic disorders.	Injuries.	Safeguarding workmen, traffic regulation, etc.

This chart, originally prepared by Dr. C. Macfie Campbell, of Harvard, for the National Committee for Mental Hygiene, is reproduced here by their kind permission.

time and generation after generation; and it is this orderliness, this definite procession of physical and chemical processes, rather than anything in the processes themselves, which is the most distinctive characteristic of life." Sometimes we are led to suppose that the processes of organization and regulation appear only in living organisms. This supposition does not recognize either the unity in nature nor take cognizance of the close relationship between the organic and inorganic worlds.

The regulatory power is one of the fundamental properties of protoplasm, and forms the physical basis of life. We find evidences of its existence in all living things, in plants as well as in animals. It may be observed in connection with the study of chemical changes within living organisms, or in the phenomena of growth and mobility in the complex responses of organism due to irritability, or in the property Conklin describes as "differential sensitivity." The study of such phenomena belongs properly to general physiology, but there are certain important aspects of the subject that it is desirable to have clearly in our minds before attempting to consider those higher regulatory forms of conscious adjustment of which the human being alone is capable.

A common distinction drawn between the organic and inorganic worlds by persons unfamiliar with the modern biologic point of view is one based upon the observance of chemical differences. The processes of growth, reproduction, and movement, however, in living tissues are represented or find their analogies in the inorganic world. Even the property of irritability, or the capacity to react to external stimuli, is a phenomenon that at least has a close analogy in many physico-chemical processes. It is not the specificity, then, of any single reaction that separates the living from the dead, but the totality of the reactions associated with the former that gives the vital processes a specific mark of distinction. Many of the so-called reversible chemical reactions have features suggesting vital processes. In the complete reactions the process continues without halt

until one or the other of the compounds in a solution has entirely disappeared. Other examples occur, however, in which the reactions cease when an equilibrium has been established. The restitution of the original substances or their complete disappearance depends upon the direction of the reaction; and this is determined by a number of conditions. In other words, these incomplete, or reversible, reactions are capable of being regulated. But in the case of biologic reactions the exact definition, or localization, of this regulating power becomes increasingly difficult because the regulatory processes governing the activities of living beings are much more complex than are those taking place in solutions. The occurrence of rhythmic contractions has been noted, for example, in connection with air bubbles formed under water to which a continuous stream of alcohol is conducted by means of a glass pipe. Probably all vital processes are rhythmic, even those resulting from what seem to be stimuli acting continuously.

The processes of adaptation have as their object the restoration of the physiological balance of an organism, its protection against injurious forces, and the perpetuation of the species. Many physico-chemical adaptations occurring in living organisms have a protective character. These antixenic functions illustrate the capacity possessed by living bodies to react so as to avoid injurious agencies that threaten their integrity and harmony.\*

The phenomenon we call life depends primarily upon the special property of regulated irritability that renders living beings capable of responding to stimuli of an almost infinite variety; often followed by reactions out of all proportion to the initial impulse that has provoked them. Hough draws a distinction, of both practical and theoretical importance, which distinguishes "stimulated activity" from "automatic responses." In the first instance the reaction follows the incidence of some form of external excitation; and in the second we have to do with a response following changes,

\* Fano, G., "Appunti sintetici e sulla condizioni determinanti la velocità energetica negli organismi viventi," *Arch. d. Fisiol.*, 1919, XI, pp. 203-265.

metabolic in character, taking place within the cell. The explosive character of the responses to stimulation is often difficult to explain unless we assume that living organisms possess special states of "irritable equilibrium," due to the rate of chemical changes and yet held in restraint by regulating forces. Probably this special form of irritability is produced by the breaking up or disintegration of a portion of the dynamic reserve energy, which is converted into some substance so sensitive that even a slight disturbance of the general equilibrium will immediately bring about a more or less sudden decomposition. This is an important conception, not only in furnishing a hypothesis of value for investigating the lower orders of responses, but in its application equally to those in the higher planes. An analogy is sometimes drawn between the unstable equilibrium or special irritability of living bodies and the conditions arising when certain inorganic substances, such as chlorate of potash, are kept for some time. One of the results, probably caused by oxidation, is a gradual transformation into highly explosive materials. Investigation has demonstrated that the conditions determining states of irritability or sensitivity occurring in all living bodies depend to a large extent upon similar physical changes occurring in the cells. A response to stimulation is brought about by the disturbance of the physico-chemical equilibrium following changes in the environment.

An investigation of the causes determining this equilibrium opens up an interesting field for research. If conditions in the environment are suddenly changed, a marked increase of the permeability of the animal cell membrane seems to be the result, and a difference in electrical potential follows. In these elementary arrangements we see a fine illustration of the delicacy of the mechanism by which even the higher forms of adjustment are made possible.

"Nature has apparently," says Lillie,\* "found in the

\* Lillie, R. S., "The General Physico-Chemical Conditions of Stimulation in Living Organisms," *Pop. Sci. Mon.*, 1914, LXXXIV, p. 579; "Nervous and Other Forms of Protoplasmic Transmission," *Scientif. Mon.*, 1919, VIII, nos. 5-6.



variations of permeability and of electrical polarization that external changes may cause in the protoplasmic surface-films the most effective and reliable means by which the internal processes of the protoplasmic system can be made to vary in response to disturbances in the environment; and in the course of evolution this mechanism has acquired a degree of perfection that still largely baffles physiological analysis."

The living organism is a system in equilibrium, constantly changing in order to compensate for or minimize any external disturbance.\* What is usually called the stimulus is some process that shifts the balance and usually is followed by an attempt at readjustment. A stimulus, then, as we shall see presently, is any change in relation between an organism and its environment. Changes beginning in the environment are heterotrophic, and those within the organism are autotrophic.

Systems are represented by the organization in a cell, cells, and organs, as well as in the individual organism or groups of organisms. Hooker has defined an organism as a system that perpetuates itself by autocatalysis and reacts according to the laws expressed in the theorem of Le Chatelier. The phenomena of organization are strikingly illustrated in the case of the nervous system, and therefore it is important to refer to some of the biological principles involved in the functioning of these particular organs. -

An accumulation of energy takes place probably in the outside layer of the nerve cell, and leads to the storing up of unstable compounds that form discharging conditions within the cell body. These are exploded in response to stimuli arising without or within the nerve cell, since in the process of adjustment we must consider not only the stimulus and reaction but also the elaborate preparations made to insure response by adequate preparations for the discharging condition.†

\* Hooker, Henry D., Jr., "Behavior and Assimilation," *Amer. Naturalist*, 1919, LIII, p. 506.

† Hough, T., "The Classification of Nervous Reactions," *Science*, 1915, N. S., XII, p. 407.

During the evolutionary process the range of organization was greatly extended by the introduction of the nervous system. Tashiro, by constructing an exceedingly delicate apparatus for detecting the presence of very minute quantities of carbon dioxide, has drawn attention to two factors which seem to be essential for organization by their provision for the production and conduction of every form of nerve impulse. He thinks that the underlying activity depends probably upon the existence of certain unstable compounds, and that the direction of the flow of impulse will be from the point of maximal toward the point of the lower chemical activity. The attempt to preserve this physico-chemical equilibrium conditions all efforts of the individual organism to adjust life to environmental changes; and this effort to meet existing exigencies forms the connecting link between all the different levels. Movements are at first incoördinated, and are executed without the intervention of a nervous system. Gradually these relatively simple responses become rhythmical and co-ordinated, representing phases in their evolution that are correlated with an increase of complexity of structure, indicated by the appearance of a special regulatory mechanism of adjustment, viz., the nervous system.

Because life is a continuous process of adjustment, living organisms are obliged to carry on work continuously and to be constantly engaged in discharging energy; while at the same time they must be ready also to supply material that will serve to guarantee the integrity of the individual organism and of the species. Three primitive "drives"—one the tendency to preserve the physiological balance, the second, to secure the safety of the individual, and the third, to insure the perpetuation of the species—are the dominant forces in life. In order to understand how these forces act we must study not only the parts of the living organism but also its behavior as a living harmonious unit.

It is unfortunate that the terms employed in describing any form of reaction have been reserved hitherto for the description of a single phase. Baldwin, in order to obviate this difficulty, suggested, more than twenty years ago, the

term "circular reaction." He showed that any living organism has a well-defined general capacity to focus or concentrate upon the part of the body under stimulation, and to react in a manner that tends to prolong the action of beneficial, and to retard the injurious action of harmful, stimuli. It is important for us to remember, in studying the behavior of living organisms—whether it be an amoeba or a man—that we should consider the adjustments taking place not merely in reference to the localized stimulus but in relation to objects and situations in the environment.

The factors conditioning all vital reactions may be collectively and conveniently designated as the *energetic situation*,\* a situation that for the purpose of description and study may be said to consist of (1) the external energetic situation, made up of all the factors outside the organism having any relation to it (heterotrophic factors), and (2) an internal energetic situation (autotrophic factors), divisible into (a) an elementary energetic situation and (b) one depending upon processes set in operation by the primary state of irritation. If, then, the equilibrium of forces in which any plant or animal exists be disturbed, a series of complicated changes generally follows.

With the occurrence of a disturbance the organism passes from a state of primary indifference into one of irritability which, upon the restoration of the equilibrium, is succeeded by a secondary state of indifference. That phase of the state of irritability corresponding in point of time with the continuous action of the original disturbance—or what we usually call the stimulus—is referred to as synchronous, whereas the phenomenon persisting after the stimulus has ceased to act is described as the deferred phase. Some investigators assume that the irritable substance, the protoplasm, as the result of disturbance is probably permanently altered. The hypothetical changes, the effect of the registering action of the stimulus, have been called engrams or imprints.†

\* Semon, R., *Die Mneme* (Englemann, Leipzig, 1911).

† Harteg, M., *An Introduction to a New Edition of Butler's Unconscious Memory* (Dutton, New York, 1911).

The so-called "mnemic phenomena" include hypothetical residual changes supposed to be left in all irritable substance after the tissue has been subjected to stimulation. The term is more general than neurogram, suggested by Morton Prince,\* which is restricted to imprints stamped only upon the brain and nervous system. Prince has wisely insisted upon the reasons for distinguishing carefully between two aspects of memory: namely, the process of recollection and the state of consciousness or actual memory picture.

All organisms under certain conditions have the capacity to reproduce impressions once stamped upon them. One phase of this general function is commonly called memory. The recollection of a single link in a long chain of events in the case of psychological memory may be sufficient to recall some special series of imprints (engrams). Thus a harsh word spoken to a dog or the sight of a stick in the hand may lead to the drooping of his tail and a hasty retreat; reactions induced by the memory of a former unpleasant experience.

The reproduction of a part of a complex tends in such an instance to bring back the entire synthesis, emotional as well as mental. Even as low in the scale of life as is the snail we meet with reactions suggestive of the recollection of so-called emotional states. In the adult snail, for example, there are responses indicative of a state of fear, which are accentuated by contrast with the failure of the young snail to adjust activities to meet similar conditions—phenomena which are due to the development of the nervous system.†

When an imprint is reproduced it tends to vibrate either harmoniously or discordantly with the original irritation. In the case of the former we speak of the condition as one of homophony. Excellent examples of the homophonous and of the discordant recall of imprints are observed in

\* Prince, Morton, *The Unconscious* (The Macmillan Co., New York, 1914).

† Dawson, Jean, *Biology of Physa. Behavior Monographs*, I, no. 4 (Henry Holt & Company, New York, 1911).

connection with the attempts to imitate the sounds of birds or animals. The successful imitator strikes a harmonious note and is able to elicit a response from the animal; but every one knows how easily a bird takes flight or an animal runs away as soon as it hears a sound with which it is not familiar.

While referring to this subject of memory it is worth noting that Hering, who first proposed the terms organic memory, did not intend that they should imply that the processes of growth and reproduction of the organism were identical with the specific forms of memory associated with special activities of the brain. Although upon superficial analysis these phenomena of organic and psychologic memory (or retentiveness and memory, as sometimes distinguished) appear to be essentially different, we shall profit by assuming that many of the functions conditioning them are common to both.

Organic memory is assumed by some writers to occupy a middle position between the *m*neme, which represents the persistence of certain physical and chemical effects, and the phenomena commonly referred to as psychologic memory.\*

In attempting to find adequate explanations for such very complex phenomena it is well to remember, as Haldane† has cautioned us, that, while there is a sense in which it is permissible to speak of organic memory, this persisting tendency suggests the nature of inertia and does not have the characteristics of conscious memory. Moreover, we should guard very carefully against the tendency to describe the phenomena of memory or consciousness in terms which are selected merely because they are acceptable to the physicist or chemist. Haldane is on safe ground in suggesting that the real world is not merely a physical or biologic world; it is also a known or remembered world. The schematized physical conception so often employed to express the relations of biological and physical processes may be very

\* Dugas, L., "La Mémoire organique," *J. de Psychol.*, 1915, XII, Jan., Feb.

† Haldane, J. C., *The New Physiology and Other Addresses* (Chas. Griffin & Co., London; J. B. Lippincott Company, 1919).

misleading. There is no doubt that for the present, special biological conceptions serve a useful purpose in the discussion of these subjects. At present the question of whether the law of causation as applied to physical phenomena holds for the psychological reactions is largely a philosophical one. We do know, however, that there are many reasons for believing there is an intimate relation between body and mind, although we may not be prepared to admit that the links in the chain of causal interdetermination are always apparent.

Memory, as we ordinarily use the word, includes other functions than mere retentiveness, since it involves a comparison of past and present events. I meet an old friend, see his face to-day, and in "remembering" compare the features with my mental picture formed years ago.

In organic memory we have to do not only with an act of recurrence, but with a recurrence often taking place independently of external stimulation. Organic memory is concerned with the reproduction of acts and psychologic memory with ideas. Many attempts have been made to find a satisfactory explanation of the phenomena of psychologic memory, but very little is known yet in regard to these very important processes, probably because they have been discussed in terms of a very crude materialism, and not presented in those suggestive of very complex biologic reactions. In the case of the mental reactions nothing has any appreciable duration unless associated with the capacity of the nervous system to register and recall traces of movements. Without this capacity our conscious processes do not function. There is no mental activity not associated with movement. The special mental activity should always be considered in relation to the general activity of the organism,\* and not, as is so often the case, as if it had no bearing upon it.

The simplest reflex action and the highest forms of conscious adjustment are equally the expression of laws as

\* Leclerc, A., "Habitude et troubles mentaux," *Rev. philosoph.*, Sept., Oct., 1919, nos. 9-10.

definite as those described as the "laws of gravitation." The pupil of the eye contracts, reflexly, when a bright light strikes it; the man in walking or standing automatically maintains a balance; or he consciously readjusts feeling, thinking, and acting to meet critical situations. Although these processes are recognized as adaptations, it is well to remember "we can no more hope to crack the facts of consciousness with the atomic theory" than "to unbutton the basis of chemical combination with Weber's Law."

When compared with conditions existing in inanimate objects, it is apparent that living organisms show a great degree of adaptability to meet new demands. If a stone, for example, is struck and a piece is chipped off, only slight readjustment takes place, and the stone shows no tendency to regain its original form. On the other hand, one of the chief characteristics of all living organisms is their possession of a certain plasticity which enables them, when injured, to retain or regain their original form, provided the incident stimulus has not been excessive; they have a degree of resiliency not possessed by the inanimate object. Plasticity is a sign of both life and function. If the balance be upset the recurrence of what seem to be conditions identical with those existing before the balance was disturbed has merely the appearance of actuality. Any individual animal at a given moment can never be identical with the one existing a moment later.

The general character of the reactions occurring between each individual organism and the environment is practically the same—whether it be a simple single-cell protozoan or the highly differentiated primate. If we watch a jellyfish floating quietly on the surface of the sea on a calm day it will be noticed that there are relatively long periods when the organism drifts about without making any spontaneous movements of its own. There is an apparent balance of forces between the conditions outside and those within the animal; but even when it is seemingly at rest constant chemical and physical changes, physiological adjustments, are taking place within its body. However, if the balance

of forces be disturbed a reaction occurs and the jellyfish makes an attempt to adjust itself as best it can, a sensorimotor adjustment, to its new and changed environment. A slight ripple on the surface of the water may be the stimulus that causes the jellyfish to leave the top and sink to the depths at which a physiologic equilibrium can be restored. Again, when the jellyfish moves, it does so as the result of a disturbance of equilibrium in a long chain of potential activities; in other words, there has been a disturbance in the entire energetic situation.

Studies have been made of many of the factors giving rise to the disturbed chemical equilibrium that causes pulsation in the jellyfish. These movements are attributed to the slight excess of soluble sodium occurring at the ganglionic centre; a condition probably brought about by the action of impinging stimuli.\* Reactions of this general character taking place between the organism and the environment are the causes not only of the rhythmical pulsations of the heart but of the more complicated co-ordinated movements of the higher animals; in fact, all types of adjustment in which the nervous system is concerned depend upon similar reciprocating mechanisms. In all kinds of animals the equilibrium of the body is so delicately adjusted that when the balance is disturbed it is usually easily restored without the expenditure of very much effort. This is beautifully illustrated † in man by the very delicate adjustments, physical, emotional, intellectual, taking place as the result of changes in altitude such as are common in mountain climbing or flying.

The various processes of adjustment going on within organisms are not only closely related to each other, but are intimately dependent upon the physical and chemical changes continually occurring in the external world. Therefore the activity of any individual—and it is the same

\* Mayor, Alfred G., "Rhythmical Pulsation in *Scyphomedusæ*" (extracted from Publication 102, Carnegie Inst., Washington, VII, pp. 113-131); also "The Cause of Pulsation," *Pop. Sci. Mon.*, 1908, LXXV.

† Schneider, Major E. C., "Altitude Physiology," *Manual of Medical Research Lab.*, War Dept. Air Service, Washington, 1918.



whether that individual is a jellyfish or a man—cannot be considered apart from the world in which it lives. This principle applies equally to the investigation of all forms of living matter. The constant inseparable interaction of two sets of factors and the play of the one upon the other, making up the process that is called life, are described collectively as the phenomena of adjustment. These processes of adjustment are illustrated by the effort of the plant to turn its leaves toward the sun, the mad rush of small fish to escape the enemy, the flight of the bird seeking its southern home for the winter, or by the response of any of man's self-conscious activities.

These adaptations of organisms are divisible into two groups which are not, however, generically different. In the first group are those that are general or direct. We touch the jellyfish and it moves, or a frog and it jumps. In the second group are those responses that may be designated as local or indirect. We cut off the tail of a tadpole and nature makes an attempt to grow a new one; or in the case of injury to other tissues, an accumulation of cells takes place and an effort at regeneration follows.

Up to a certain point, in the case of both local and general reactions, a special mechanism of readjustment is not absolutely necessary, although the nervous system is essential to the completion of a complicated reaction. We know, for example, that the property of irritability, the basis of all adjustments, does not depend upon the presence of a nervous system, but is one of the fundamental characteristics of all living matter. Even in the embryo of the higher animals the highly differentiated nervous system does not appear until a comparatively late stage of development; and in the case of local reactions readjustment of the parts occurs without the intervention of nervous tissue.

The components of the special mechanism of adjustment, the nervous system, are identical in all animals. The nerve cells and fibres composing it are practically the same in the whole animal series, and essential differences in its

structure are probably due to a numerical increase of nerve cells and fibres and to their arrangement, rather than to the possession of divergent specific properties.

We know also that the nervous system considered as a mechanism of adjustment has not the exaggerated importance in connection with behavior that once was ascribed to it. The mere presence of nervous tissue does not *per se* indicate the existence of specific functions. Certain movements, such as those of mimosa and other plants, represent forms of readjustment taking place without the intervention of nerve cells and fibres. There are also plants capable of detecting differences in illumination to which the human retina is insensitive.

The question is sometimes asked whether certain responses of plant life are not directly comparable to the so-called psychological phenomena occurring in the higher animals.\* The answer depends upon our concept of the word "psychic," which may be either a very restricted or a very comprehensive one.†

From one point of view it may be said that the lowest or simplest forms of reactions in plant life are not capable of being sharply differentiated from those taking place in the highest planes of activity, even in the self-conscious levels. Furthermore, we cannot imagine the latter existing without the former, and therefore conscious adjustments may always be considered as depending upon or superimposed upon those in the reflex plateau. As far as we know, there stretches an unbroken chain uniting the whole line of biologic activities from the simplest reactions of plants to the highly organized psycho-biologic responses of man.

Returning now to the case of the animal, it is evident that the reflex is not to be regarded as the fundamental unit of behavior. There are organisms in the lower order, such as the protozoa, in which special neural structures, and therefore neural reactions, or reflexes, do not ex-

\* Acqua, C., "Esistono fenomeni psicologici nei vegetali?" *Scientia*, 1914, XV, p. 187.

† Aristotle's tripartite division of souls included plants, animals, and human beings.

ist. In the higher animals, during the early stages of embryonic development, movements also occur at a period preceding the appearance of nervous tissue. Later in life the nervous system undoubtedly assumes control and elaborates the activities of even the more fundamental rhythmic phenomena; and this assumption of control rather than the creation of entirely new functions throws light upon the actual rôle played by the nervous system and upon its functional units.

In tracing the evolution of functions we may follow many of the steps by which the simple methods of progressive adaptation of the lower organisms are transformed to meet increasing needs imposed, for example, by the development of such apparatus as the respiratory mechanisms and of the various defensive and offensive reactions, including those occurring in man at the mental level, all of which are essential for the preservation of the individual.\*

The most primitive apparatus for respiration is probably of such a nature that there is direct interchange of oxygen and carbon dioxide between the cells and the environment. When the geographic relations between the animal and the environment remain stable for any length of time local asphyxiation occurs, and the activities of the primitive mechanisms then drive the organism to some new spot in which a fresh supply of oxygen is available. It is obvious that the more rapidly the environment changes, the greater is the demand for immediate and satisfactory arrangements for effecting a complete adaptation to meet new conditions of life. It is equally true that a large number of the external forces to the action of which the organism is exposed call for a rapid extension and specialization of reactivity in order to prepare the way for a successful defense against hostile influences. The increased sensitivity of one living body as compared with a second one measures the equipment available for insuring protection.†

\* Brown, T. G., "On the Nature of the Fundamental Activity of the Nervous System," *J. Physiol.*, 1914, XI, p. 18.

† Bayliss, W. M., *Principles of General Physiology*, p. 530 (Longmans, Green & Company, London, 1915).

The struggle of the organism to maintain a balance of forces is constant, and only ceases at death. The effort made to receive and assimilate whatever is useful and to reject and repel injurious influences is represented in many different forms. One of the chief functions of the nervous system, as we shall see, is to co-ordinate and unify the defensive forces of the body and "to organize the victory of the antixenic functions."\* In the constant struggle to maintain the balance in any living organism energy is being stored up and discharged by an autonomic apparatus, first in one direction and then in another. In the main this autonomic control of the energy supply is a function of the sympathetic nervous system. As a result of the control there is a steady flow of vital forces which are as delicately responsive to the demands made upon the organism as is the mercury in the thermometer to the sun's rays. The ebb and flow of these tides represent opposite forces, and the adjustment or balance is maintained in human beings by reflex, automatic, and conscious adaptations.

The transference and transformation of energy are constantly taking place. The mind as well as the body during health maintains a certain balance between the processes concerned in the production, transformation, and discharge of energy. A discharge in one direction is not a complete liberation of so much force, as the opposing tendencies are active, although to a less degree. This is well illustrated by the first slow movements of the embryo, generally occurring in groups and all in the same direction. Gradually the restoration of an equilibrium is effected, and the "wings of the body are repeated toward the opposite side.

These primitive responses of the vertebrate embryo reproduce many of the stages observed in the less complex forms of animal life. First of all there is the period in which the slow rhythmical contractions of the body occur prior to the appearance of differentiated nerves.† These con-

\* Grasset, J., *La biologie humaine* (Flammarion, Paris, 1917).

† Paton, S., *Compar. Neurol.*, Aug., 1911, XXXI, no. 4; *Proc. Am. Phil. Soc.*, 1913, III, no. 211.

tractions are comparable to the opening and closing movements of the oscula and pores of the sponge.\* But the importance of these primitive responses in relation to the development of the nervous system is exhibited both in the life of the individual organism and in their bearing upon the increased complexity of function in vertebrate evolution. These comparatively simple responses in the form of rhythmic movements, preceding, as we have indicated, the introduction even of protopathic sensory functions, may be regarded as the functional units out of which the more complex adaptations like locomotion and respiration develop.

In the adult, when the mechanisms of automatic adjustment are fully operative, movement is more effectively controlled by opposing groups of muscles, and the nature of these reactions is determined by the presence of receptors, conductors, and effectors. In man a highly developed system of autonomic control regulates to a large extent the activities of the proficient sensori-motor apparatus by which the organism readjusts itself to changes in the environment.

The special mechanism of adjustment is composed of sense-organs, or receptors, adjustors, and effectors, or the discharging apparatus. The receptors, or sense-organs, representing the points of direct contact of the organism with the environment, are upon the outer surface and are, within certain limits, attuned to receive incident stimuli (sound, light, heat, etc.). The proprioceptors, sense-organs lying below the peripheral layers, have as their function the coordination of reactions. When the impinging stimulus is received by the eye, ear, sense-organ in the skin, or by any of the other forms of receptors, it may be transmitted, and at the same time probably undergoes transmutation in its passage through the adjustors before being discharged by the third group of elements, which are connected with the

\* Very interesting observations have been made upon these primitive responses by Lane. Lane, H. H., *Correlation between Structure and Function* (University of Oklahoma, 1917).

muscular, glandular, and other systems that enable the animal to react upon the environment. The sound waves, for instance, which are picked up by the specially attuned auditory apparatus of certain insects make no impression upon the human ear. The ear of the dog, according to Pawlow,\* is capable of excitation by sound waves with oscillations running as high as 70,000 to 80,000 per second, whereas the capacity of the human ear is limited to those below 50,000. It has also been observed that dogs are able to detect differences of one-fortieth of a second in the rhythmic beats of the metronome. The receptors are adequate for the needs of the organism in making adjustments possible in response to certain stimuli; and they have a discriminating capacity varying both in different species and within wide limits in individuals of the same species. The ranges of sensitivity in man are indicated in the table on page 175, copied from Hollingsworth and Poffenberger.† Very few people appreciate what an important relation this sensitivity has to the entire mental organization. The paths by which incident stimuli are conducted to the brain are the main avenues of supply for the information necessary in the adjustment of life. Even if hearing, vision, smell, and taste are seriously disturbed, very valuable information in regard to the environment may still be supplied to the mind by touch, movement, temperature, and the vague, and often very puzzling, organic sensations.

Although the functional capacity of the receptors must be a weighty factor in determining the nature and rate of adjustments, there are relatively few facts yet known in regard to this important subject from which deductions may be made. It has been observed that the rate and method of learning in blind and normal dogs shows surprisingly little difference, and in these animals the comparatively slight use made of vision is undoubtedly compensated by the kinesthetic and muscular sense processes.

\* Johnson, H. M., "Audition and Habit Formation in the Dog," *Behavior Monographs*, II, no. 3, serial 8 (Henry Holt & Company, New York, 1913).

† Hollingsworth, H. L., and Poffenberger, A. T., *The Sense of Taste* (Moffat, Yard & Company, 1917).

The muscular system, which plays such an important rôle in all adjustments, appeared in the course of evolution before the nervous system was differentiated. In the lower forms of life such as the coelenterates the nervous system comprises receptors and effectors, but the adjustors are represented by very primitive mechanisms. The possibility of simple restricted forms of adjustment existed in the muscular tissue, but in order to insure co-ordinated movements a controlling mechanism, the nervous system, was developed. Organisms like sponges possess muscle cells but no nervous system, and their slow contractions or adjustments to very limited forms of stimuli seem to take place under direct stimulation without intervention of nerve cells or fibres. It is a very long jump, however, from the primitive responses of the sponge to the highly complex activity of the human being; yet by comparing the adjusting capacity of the two classes of animals we get an enlightening glimpse into some of their chief structural and physiological characteristics. The highly developed individuality of the latter depends upon the unity imparted to its activities by the nervous system, or, as Parker so succinctly expresses the contrast, "a sponge may be outlined as a metazoan whose organization concentrates on feeding and reproduction; a human being may be described as one whose organization centres around a nervous system."

An approximate idea of the time and manner in which the nervous system begins to assume control over behavior may be readily estimated. We find these beginnings may be noted either in the life history of the individual or in the development of the race. Just as there is a mechanism for the regulation of behavior in the sponge which does not contain any tract for the conduction of sensory impressions, so in the vertebrate embryo the earliest reactions take place without any provision existing for the registration or reproduction of sensations. The apparatus conducting sensations, first the protopathic for transmitting vague, and then the epicritic for more specific sensations, develops relatively late both in the individual and in the race. Action, as

Parker\* reminds us, is the oldest and most ingrained of our nervous functions. Abundant proof for this view may be obtained by following carefully the steps in the development of the spinal cord in the embryo. Areas destined to become lines for the carrying of motor impulses are sharply defined, and are evidently in working order long before those conveying sensory impressions. Doubtless the "memories" associated with muscular activities, and which are millions of years older than those connected with the nervous system, exert a very important influence in preparing the foundations for conscious adjustments. The general muscular tonus has an immense effect in giving the set which finds expression in our emotional preparedness, desires, and in the determination of our trains of thought. As a matter of fact an understanding of the fundamental motor dispositions is of immense importance to explain how the more or less concealed attitudes pass into overt action.†

It is a significant fact that, if the stream of energy does not exceed certain limits called normal, organisms tend to preserve the unity of their reactions, even when subjected to unfavorable surroundings; and this characteristic may be observed in all living bodies from the simplest to the most complex. For example, the amoeba, when brought into contact with a substance of nutritive value, may stretch out a pseudo-podium in response to chemotaxis, but the negative quality of retraction incident to contact with noxious substances is not equally well marked. This satisfaction and dissatisfaction expressed by movements called forth in response to these stimuli, are reactions of basic importance in all organisms.

In the course of evolution, as the number of cells in living organisms multiplied, special groups of cells were connected with different functions. In order to preserve the unity of the more complex organism some kind of machinery was necessary to establish close reciprocal activities between all

\* Parker, G. H., "The Sources of Nervous Activity," *Science*, 1917, N. S., XLV, p. 619.

† Holt, E. B., *The Freudian Wish* (Henry Holt & Co., N. Y., 1916).



these groups. This unity was established and maintained by the automatic nervous system. The unstriped muscle cell, the motor element in organs over which we do not exercise voluntary control, is part of the autonomic system which is millions of years older than the brain and spinal cord, or the projicient system. The sensori-motor apparatus, represented in vertebrates by the spinal cord and brain, developed at a much later stage; and this supplementary provision for adjustment greatly extended the range of adaptation. The old primitive part of the mechanism of adjustment, the autonomic system, still has very important functions to perform in man, as it co-ordinates and regulates organs connected with the intake, assimilation, and storing of energy, including the digestive, circulatory, and secretory systems, sex organs, and those regulating growth, together with the supervision of metabolism for emergencies and the enormously important postural tonus of the muscles.

Before the projicient system was developed the autonomic system was constantly irritated by stimuli in the environment, from which there could be no escape, and to which no adequate reply could be given in the form of successful readjustment of the disturbed balance. This defect was remedied by the appearance and subsequent development of the spinal cord and brain. When the affective balance is once disturbed by the autonomic system, the subsequent movements called forth by the projicient sensori-motor system are undertaken in order to re-establish the physiological integrity.\*

The activities of all living beings are organized; that is to say, they are closely related to each other in such a way that they are interdependent. The phenomenon of co-ordination consists of varying degrees, and, as Sherrington† has shown, in its simpler forms is represented biologically

\* Kempf, Edward J., "The Autonomic Functions and the Personality," "Nervous and Mental Disease," *Monograph* no. 28, 1918.

† Sherrington, C. S., *Integrative Action of the Nervous System* (Yale University Press, New Haven).

by the mechanical combination of various cells to form an individual. The integrative action of the nervous system is best observed in states of health; whereas the antithesis, disease, represents many forms of disintegration.

The machinery of adjustment represented by the nervous system has two main purposes: one, to harmonize the activities of the individual; and the second, to keep it in contact with the environment. In the higher organisms, such as man, the complexity of function seems to be in direct proportion to the number of contacts maintained by the environment.

The adaptation taking place in the higher levels of conscious activity in man seemed formerly to be so complicated and the superficial contrast between functions appeared often so marked that there was some justification for assuming the existence of specific differences; and this supposition led to the establishment of a faculty-psychology. Adaptations taking place in the conscious levels were supposed to emphasize the gap crossed that marked man's elevation from the brute level to a height of immense superiority. The complete absorption in studying either the mechanism of adjustment or the myopia produced by pride made man forget to study his own reactions from a view-point similar to that successfully adopted for the observation of other animals in which responses were recognized as biologic units.

Any investigation of the various mechanisms of adjustment to be of actual service must consider all adjustments as biologic reactions which are so closely related that it is often impossible to distinguish the links in the chain.\* The temptation to assume the existence of specific differences is naturally greater in connection with conscious processes than it is in any other level. For this reason it is desirable to remember how deeply rooted the conscious reactions are in the field of the subconscious. As we shall

\* Meyer, Adolf, "Objective Psychology or Psychobiology with Subordination of the Medically Useless Contrast of Mental or Physical," *J. Am. Med. Ass.*, 1915, LXV, pp. 860-862.

see later when discussing the phenomena of organization and dissociation, consciousness is a function of the individual's adjusting or biologic capacity to react, which secures adaptation to the conditions of the environment and changes in the environment in accordance with the needs of the organism.\*

As a matter of fact we should not speak of the consciousness of a psychic state of itself, but of the consciousness a present psychic state has of a past one.† The sterility of the conception of consciousness as it was once formulated was a result of the method of studying this phenomenon comparable to that employed by the natural philosophers who, before the discovery of the wave theory of light, were satisfied to describe the properties of light by rigid definition; without any attempt to discuss either the fusion of the various rays in white light or to trace the relation of light to other forms of energy. So consciousness was forcibly detached from its biologic setting and its phenomena were described in terms selected arbitrarily by the doctrinaire and controversialist who, for the purpose of establishing the correctness of their views, erected a series of defenses, some of which suggested the properties of barbed-wire entanglements. Fortunately to-day the biologist has made very plain the reason for the abandonment of the conventional, narrow, and sterile conception of consciousness, and substitutes for the rigid limitations imposed for centuries upon the student of mental phenomena a view of behavior and conduct that shall at least suggest the constant ebb and flow of the vital processes.‡ The arbitrary division between the voluntary and involuntary reactions, between the conscious and subconscious, is not only unscientific but useless.

Gradually we are beginning to realize that in order to understand the nature of the conscious adaptations they must be considered in relation to all other levels upon which

\* White, M. A., "The Unconscious," *Psycho-Anal. Rev.*, 1915, II, p. 121.

† Regnano, E., *Essays in Scientific Syntheses* (Open Court Publishing Co., 1918).

‡ McDougall, W., *Social Psychology* (Boston, 1915).

they rest, and that, above all else, we must avoid the ancient fallacy of discussing consciousness as an entity, the dilemma by which many of the past generation of psychologists were confronted. In this connection it is interesting to note that William James, rather early in his career, mistrusted consciousness as an entity, but recognized its biologic significance when he referred to the "streams of consciousness." Notwithstanding the present tendency of some biologists to discard the term "consciousness" and to substitute "behavior" or "adjustment at higher levels," there seems to be no adequate reason to justify the abandonment of the word merely because of certain implied significations attached to it.\*

Those who have formerly associated the word "consciousness" with certain metaphysical conceptions should not precipitately cast the term aside merely because its repetition serves to recall the memory of conflicts incident to their own mental development,—conflicts the memory of which they wish either to repress or to ignore. In the older and mystic sense consciousness was a misnomer, but as it has been revised in the light of modern biologic studies there is at present less reason to throw overboard the term than there may be at some time, probably in the near future, to find a substitute for "behavior." The term serves a very useful purpose, and, if we appreciate, as Ward has said, that its manifold ambiguities are more or less of a scandal, we shall not be in any danger of servilely accepting any of the recognized objectionable applications.

The organism is kept in touch with the environment through the activities of the sense-organs; and these in turn are directly connected with the great mechanism of adjustment, the brain and nervous system, which also links together the functions of various organs. Modifications or changes in the sense-organ, nervous system, internal organs, or in the environment result in "the shift" in the equilibrium that supplies the stimulus.

\* Watson, J. B., "Behavior and the Concept of Mental Disease," *J. Philos. Psychol. and Scientif. Meth.*, 1916, XIII, p. 589.

The various levels at which adaptation takes place and an indication of the modifications apt to occur as the result of directing events in the life history are represented in two diagrams by Campbell and Glueck. The simplest as well as the earliest adjustments to occur in life are vegetable or physico-chemical, followed by the sensori-motor; and last and most complicated of all are the psychic or symbolic.\*

Behavior should not be considered as a function only of the brain and nervous system. A broader outlook is not only desirable but essential. In trying to analyze the various phenomena we must have not only a fairly comprehensive idea of the rôle played by the different parts of the nervous system, but an understanding of the reciprocal influences of other organs before attempting to explore such complex reactions as are concerned, for example, in the phenomena arbitrarily described as "character," "intelligence," or the "personality."

The behavior of all higher animals, including man—their movements, whether reflex, automatic, or volitional, the adjustment in all levels, including the conscious—depends upon the capacity to receive, store up, elaborate, and transmit impressions stamped upon the organism. All the more complex organizations are based upon the processes of *correlation*, *co-ordination*, and *association* of impulses. In the *correlation* of incoming impulses occurring within sensory centres there is, as Herrick has said, a selective activity at work sorting out the elements to form an integrated series of responses able to secure for the organism a successful adjustment. In this organization both receptors and correlation centres are involved. In *co-ordination* mechanisms are called into action necessitating the participation at the right moment of different groups of muscles, and here the adaptation is chiefly concerned with the effector system. The term *association* is usually applied to correlation and adaptation taking place in the higher levels when there is

\* White, W. A., and Jelliffe, S. E., *Journ. Amer. Med. Asso.*, 1916, LXVI, p. 781.

marked divergence from such stereotyped reactions as the reflex.

It is helpful when considering the multiplicity of factors concerned in these reactions to keep in mind some of the machinery provided for insuring an increased complexity of function and more complex organization. There is indeed a marked contrast in the arrangements for organization provided for in the very diffuse ganglionic system of the invertebrates as compared with the metameric distribution of the vertebrates, although the neural elements in both are the same. The nervous system in the lower types of animals forms a network for the older form of organization; an arrangement quite different from the synaptic condition characteristic of the higher organisms. In the latter we find both types are present. This older system contains both sensory and motor nerves and is sometimes called the vegetative system. The word "vegetative," as applied to certain parts and functions of the nervous system, has great historic as well as biologic significance. Cuvier pointed out long ago that its functions are more reminiscent of plant than of animal life.

This vast apparatus or autonomic system is a silent participant in the regulation and control of organized activities; but although silent it possesses extraordinary importance in providing means of adaptation, sometimes described as "unessential," but which as a matter of fact are intimately connected with another apparatus of vital significance to the organism. The nervous supply distributed from this vegetative system to the various organs, such as the heart, lungs, thyroid, adrenals, etc., indicates the close relation of its functional control over the organs that have an enormous capacity for modifying the workings of the central nervous system, and even of interfering with life itself. This autonomic system regulates the affective life, and in this way determines character, temperament, and indirectly promotes or inhibits the higher intellectual function. Kempf has reminded us that the physiological divisions of the body, regulating the assimilation, conservation, distribu-

tion, and expenditure of energy and the elimination of waste products, act as one autonomic system.

It is during that period when the growth of the part of the nervous system insuring volitional control of many activities reached a high point in its development that the social and moral progress of the race has been marked.\* The concentration of centres of control within the brain has contributed largely to the increase in size of the cerebrum, and this arrangement has led to man's supremacy over the lower animals. Important as is this concentration of tissue in the brain, we should not seek to minimize the rôle of the involuntary system in regulating the blood supply, controlling the movements of the body as well as the secretions of internal organs, and by these mechanisms giving the direction to the whole current of activities represented in the personality; thus insuring to each person some distinctive mark of temperament or character.

In one sense the more recently acquired mechanisms concentrated in the cerebrum seem to represent considerable independence of activity when contrasted with the older involuntary systems, but as a matter of fact the latter, although directly concerned in the performance of less conspicuous functions, yet in the final analysis exercise the whip-hand by regulating the preparation for the execution of any volitional act. The will, or rather wish, to do is to a large extent the product of the emotional states set going or inhibited by the involuntary system.

Although the nervous system is generally divided arbitrarily into parts in order to facilitate description, let us not forget that the various parts which are distinguished by their structural characteristics all function, in states of health, as one organ. Nor are we justified except for this same reason in referring to the cerebro-spinal system as distinct from the autonomic or sympathetic systems: as all the different parts have some representation in the great co-ordinating centres of the cerebrum. Viewed purely from

\* Gaskell, W. H., "The Involuntary Nervous System," *Monographs on Physiology* (Longmans, Green and Company, London, 1916).

the standpoint of the anatomist there may seem to be a wide difference between the tracts conducting impulses centrifugally and centripetally, or between psycho-sensory or psycho-splanchnic paths. We have been entirely too much inclined, however, to emphasize what we supposed were contrasts in functions and to forget that psychic no less than physical, somatic, and physiological functions were all represented in the activities of the brain; and also there has been a failure to appreciate the wonderful simplicity and unity exhibited in each adjustment effected by the nervous system.\*

The line of division of functions was formerly supposed to be the sharpest and most impassable of all barriers. As information has accumulated and as it has become more and more difficult to draw any sharp lines of distinction between the functions of higher and lower cerebral centres, so it has practically become impossible to say how or when the superior psychic reactions represented in the higher volitional responses gradually faded away until they crossed the threshold into the unconscious, and how these were brought into close touch with automatic and reflex mechanisms. Tilney,† in referring to some of the marvellously intricate and delicate mechanisms in the nervous system for securing a proper adjustment between all the different organs, has mentioned the ease with which disturbing impulses arise from the lower planes of activities represented in the so-called visceral or vegetative life, and thence become contributing causes of psychic disorders. These processes may also be reversed, thus permitting psychogenic disorders to disorganize the co-ordination of numerous physiologic activities.

The integration of the human personality is to a large extent a product of the nervous system. In order to insure complete integration, conflicting tendencies, such as are represented by antagonistic muscles or conflicting disposi-

\* Grasset, J., "La Biologie Humaine," *Bibliothèque de Phil. Scientifique* (Flammarion, Paris, 1917).

† Tilney, F., "Opportunities in Neurology," *J. Nervous and Mental Diseases*, 1917, XLVI, p. 81.



tions, are ordinarily held in complete control by a complex mechanism.

The extension or limitation of the organization existing in the field of consciousness depends upon the organization of the subconscious activities. The great field of "the unconscious," as Freud calls it, or the "personal unconsciousness," the term suggested by Jung, contains countless impressions, some transmitted from very remote ancestors and others derived from personal experiences. These impressions form the "primordial thought feeling," and supply the patterns upon which the entire emotional and intellectual life of the individual is built up.\* Out of this vast storehouse develops the feeling of understanding often more than we either have actually experienced or have the capacity to express in language. It is to these accumulated but unexpressed experiences that art, literature, and drama make such an effective appeal.†

In the field of the unconscious are buried archaic records dating from a very remote past. Some investigators, like Rivers,‡ believe that the unconscious is composed chiefly of instinctive experiences, forced down to deep levels when the exigencies of life became so numerous and complex that these primitive types of reaction were no longer useful, and were to a large extent superseded by conscious control. The changes and shifts taking place in the adjusting mechanisms as life became more complicated are analogous to what is seen in lower organisms when, for example, the mechanisms of response in the caterpillar are modified and amplified to satisfy the needs occasioned by the transformation into a butterfly.

The primitive, protopathic form of sensibility represented in the lower animals is also found in man, but this is supplemented by a much more precise and discriminating mechanism described as epicritic. In cases of injury to the

\* Prince, Morton, *opus cit.*

† Nicoll, M., "Why Is the Unconscious Unconscious?" *Brit. J. Psychol.*, Oct., 1918, vol. IX, part 12, p. 230; Tansley, A. G., *The New Psychology and Its Relation to Life* (London and New York, 1920).

‡ Rivers, W. H. R., *Brit. J. Psychol.*, Oct., 1918, LX, part 2.

nerves, followed by recovery, it is generally the older, more primitive protopathic type of sensation which first returns. The former is closely associated with instinct, whereas the higher and more specialized response is associated with the intellectual reactions. The older type marks an interesting stage in the progression from the field of the unconscious to the fully differentiated conscious adjustments.\*

There are at least two different views held in regard to the nature of the unconscious and the relation it bears to consciousness. One, as we have seen, considers the unconscious as a storehouse of the instinctive activities which have either been partially or completely rejected as no longer useful in adjusting to meet the realities of life. According to the other view the unconscious is an exhaustible reservoir from which material is being constantly drawn for the development of the entire mental life. These different theories lead to various interpretations of the relation of the unconscious to reality. Nicoll believes that the unconscious is not yet adapted to reality, Rivers that it is no longer adapted, while Jones affirms that it is sometimes but not always better adapted than is consciousness. More detailed knowledge should reveal the extent to which the unconscious is the storehouse not only for instinctive but for individual experiences, and should have a very important bearing upon all problems of human behavior.

Complete regulation and successful adjustment is expressed in the unity of the personality. For ages man seems to have been impressed only by the apparent dislocation of the processes going on in the plane of conscious adjustments, but now he is coming gradually to realize that there are no gaps between unconscious and conscious levels. We hear less about the duality of the body and mind and more concerning the unity of the personality.

\* Head, H., *Brain*, 1911-12, XXXIV, p.102.

## CHAPTER III

### SPECIAL MECHANISMS OF ADJUSTMENT

MAN, in contrast with the lower animals, possesses a relatively greater capacity to retain, elaborate, and transform impressions received and transmitted by sense-organs to higher brain centres. No specific differences in behavior, however, distinguish the activities of the former in comparison with those of the latter. Primitive man, as the result of the cumulative effect of his activities, long ago attained a position of comparative superiority in the animal world, while civilized man, acting under the influences of a still greater but a relatively limited capacity to retain and profit by the lessons of experience, has risen above his primitive ancestors. Pride has often prevented him from recognizing not only the causes of many obvious failures to adjust life satisfactorily, but also has made him blind to the factors contributing to the successful adjustment of difficulties. He has not always been willing to correct mistakes in his own life by profiting by the experience of other living beings; and in his treatment of the lower animals extermination, not adaptation, has been a dominant motive. Even in the relationships with his fellow men, the recurrence of wars among civilized nations reminds us that the impulse to exterminate, rather than any inclination to gain national profit from experience, is still dominant.

Imperfect as his adjustment of life often is, nevertheless the mechanisms by which partial adaptation is secured are of great interest. Although this is not the place to enter into detailed account of either the structure or function of the nervous system, we may devote a brief space to the consideration of some of the special characteristics of the human nervous mechanism which are responsible for the increased capacity to adapt life to meet the changing condi-

tions of a broader environment, thus enabling men to rise to a position above the rest of the animal world.

Man, in common with the other vertebrates possesses a spinal cord—an organ in which are located centres of many reflex activities as well as paths for conducting impulses to and from the higher nervous centres of the medulla oblongata, cerebellum, mid-brain, basal ganglia, and cerebral hemispheres of the brain with their highly complex cortex or rind. The human spinal cord is relatively small as compared with that of some of the other vertebrates, but the great hemispheres of the brain are proportionately larger and more complex in their fine structure than in any other one of the animal series.

The study of comparative anatomy has taught us that in the evolution of man the development of parts of the adjusting mechanism such as the sense-organs (receptors), adapted to the receipt of impressions, has not kept pace with the growth of the central nervous system (analyzers and effectors), although the more or less autonomous action of a somewhat scattered and widely distributed nervous system has been concentrated and brought under the dominating action of a central controlling apparatus, the brain. Far down in the animal series, when the degree of receptivity and reactivity for incident stimuli is low, there is no particular necessity for the organism to take very great precaution against being thrown into a state of continuous excitability. The limited range of the stimuli to which it responds is its own protection. As the tissues were differentiated and the nervous system presented a more extensive front for the receipt of impinging stimuli it became quite necessary that the reply to excitation in the form of movement should be both prompt and adequate, but it is also true that the higher the organism the greater the demand for the reception of a wider range of impressions, for association with other impressions, and often for delay and elaboration of this material before the answer in the form of a response is given. The original brain, or archeopallium of the lower vertebrates, offered only a few possibilities in this respect that were not

possessed by the invertebrates, and the result was chiefly a multiplication of the reactions of the reflex or lower instinctive types. Other modifications and amplifications were called for, as the animal in order to survive needed to be released from the necessity of answering back immediately to countless calls imposed by a more extensive and complicated environment. The original brain segments (tel-, di-, mes-, and myel-encephalon) did not supply the apparatus for these complicated adaptations, so the new brain neopallium was formed, and in this structure were represented the old nerve tracts together with the new ones, a combination which gave greater latitude in adjustment, and by increasing the facilities for retaining impressions and imposing checks the animal was relieved from the immediate necessity of replying offhand to the impinging stimulus. The arrangement permitted protracted periods of rest and recuperation in spite of the increased receptivity of the tissues, and it also served the double purpose of bringing certain functions into prominence and relegating others, like the so-called vegetative reactions, to the background. With the development of the mammalian neopallium new and important functions appeared. There were, for example, greater precision in the control and regulation of movements, and an increased capacity to learn to perform complicated acts requiring great skill. All these new mechanisms depended upon accurate knowledge of postural positions and upon the ability to judge size, shape, weight, and spatial relations. In the old brain the various impulses streaming up from lower centres were integrated at the physiological level, but the new machinery made it possible for the animal to appreciate successive spatial and time judgments, and to form psychical integrations giving rise to consecutive consciousness.\* As soon as the cerebral cortex appeared the provision was established by means of which sensations were referred to the events in the environment, and crude comparisons and primitive judgments laid the

\* Smith, G. Elliott, "The Significance of the Cerebral Cortex," *Br. M. J.*, July 15, 1919.

foundations upon which the more highly organized mental life of man was built.\*

In our ancestor the primitive vertebrate amphioxus, an animal that has had a "checkered zoological history," we find an interesting link between the scattered nervous system of the invertebrates and the concentrated metameric type found in the vertebrates. This animal, which was at first thought to be a slug, and later a fish, has neither skull nor brain; but on account of its segmental development is classified among the vertebrates. Thus while it leads a more or less sedentary life buried in the sand at the bottom of the sea, and the functional capacity of its responses and its general capacity for adaptation seem to be on a lower plane than in some of the insects, nevertheless the number and arrangement of the parts entitle it in some respects to a place higher in the anatomical scale than either ants or spiders, possessors of multiple and complex instinct activities. Since it has no brain the spinal cord of the amphioxus does not pass at its upper or cerebral end into a differentiated brain as do those of other vertebrates, and therefore, in a measure, the amphioxus retains some of the functional characteristics of the diffuse nervous system of lower organisms. Thus spots are found on the body which are sensitive to light and represent a diffuse mechanism for adjustment to light changes.

As we rise in the scale of development sensitiveness to light is concentrated in optical mechanisms, including the eyes, optic nerves, and visual centres of the brain. By comparing the capacity for adaptation to light stimuli of our lowly ancestor the amphioxus with that of animals possessing complicated brains we get an inkling of the arrangements by which conscious adjustments have extended the range of automatic or reflex activities. As the brain develops there is a corresponding increase in the capacity of this organ to regulate and control activities which, lower in the series, were to a marked degree in-

\* Tilney, F., and Riley, H. A., *The Form and Functions of the Central Nervous System*, p. 905 (Paul B. Hoeber, New York, 1912).

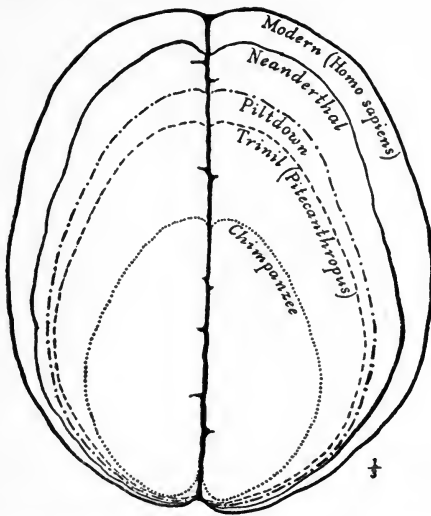

The evolution of the brain. Outlines (top view) of typical human and pre-human brains, showing the narrow forebrain of the primitive type and the successive expansion of the seat of the higher mental faculties in the successive races.

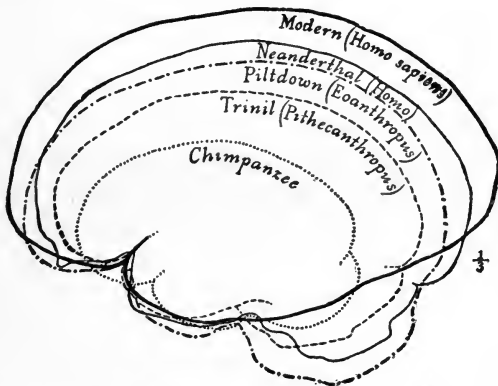

The evolution of the brain. Outlines (side view) of typical human and pre-human brains, showing the early development of the posterior portions of the brain and the relatively late development of the anterior portions, the seat of the higher mental faculties.

From Osborn, "Men of the Old Stone Age" (Charles Scribner's Sons. By permission.)

dependent. In the brain of the fish there is no structure excepting a very simple layer of cells, which corresponds with the enormous development of the cerebral hemispheres as they exist in man. This layer of cells in the fish does not contain any nerve elements, and is therefore functionally inactive. Not until we reach the amphibians do we find any trace of the structural change which later attains the great functional importance represented by the higher centres of the human brain.

The different parts of the brains of the higher vertebrates correspond to various stages in phylogenetic development; some marking periods of antiquity, others the middle ages, and finally those that are the products of a comparatively recent period. The cerebral cortex probably appeared first in animals that lived during the Trias or Carboniferous periods in geological history; and the oldest portions of the central nervous system may be considered to be the homologs of the diffuse ganglia of the invertebrates. In both fish and amphibians we find structures marking the beginning of the cerebral cortex (pallium nervosum); and this particular organ as we ascend in the scale of animal life rapidly becomes more complex, forming by means of enormous numbers of nerve cells and fibres a great cortico-somatic system which is characterized by the establishment of higher centres representing stations apparently more or less independent of the older structures of the brain. The process of differentiation, neurobiotaxis, does not lead in any of the animals to actual independence of the higher centres; both younger and older centres show marked interdependence.

In tracing the phylogenetic development of functions we are impressed by the fact that the higher forms of activity as represented by the animals at the upper end of the scale serve to bring the individual into more intimate contact with a constantly broadening environment. The more primitive types of intellectual activity are useful merely for adaptations occurring within a very limited range, and practically little provision is made for the collection and



recollection of experiences which are useful in the conservation of energy or life. The higher mental processes of human beings provide for the extension of the adjustment mechanisms to cover much broader fields of experiences than those to which the lower animals are subjected. The capacity of human beings to adjust their activities more successfully than other animals to a wide scale of living depends not only upon the common heritage of a capacity for receiving, storing up, and transmitting impressions received from the environment, but also upon the ability to select with greater accuracy causal relationships, to remember these, and to submit them for review and judgment to the higher complex faculties described as reason,—a function of the cerebral cortex.\* The unbroken connections uniting all these processes, higher and lower, should always be kept clearly before our minds, and we should never make the mistake of supposing that arbitrary divisions into separate functions or faculties have more than a descriptive value.

In different types of animals increased intelligence is generally accompanied by a proportionately greater volume of the brain as compared with body weight; while there is evident correlation between the size of the cerebrum and the general intelligence. There are many facts to suggest that the brain develops as the result of use; although we must admit that the evidence generally presented in favor of this view is not conclusive. The determination as to whether the power to develop a larger brain in the ordinary sense, in response to the increasing demands of life, has always been accompanied by a corresponding increase of the adjusting capacity, presents a very interesting biologic problem. Some of the insects, for example, seem to have a greater range of adaptability to meet the conditions of life than some of the lower vertebrates.

The exceedingly complicated mechanisms of the human cerebral cortex and the incalculable number of possibilities it offers for the integration and synthesis of impulses may

\* Tilney, Frederick, and Riley, H. A., *The Form and Functions of the Central Nervous System*, p. 905 (Paul B. Hoeber, 1912).

be illustrated by some reference to its structure. The general plan of the cortical structure is represented by two layers of nerve cells separated by an intermediary substance. The type of the mammalian cortex is the result of a fusion which has taken place during the evolutionary process of an external layer—supposed by some investigators to be principally sensory cells—with one that is also assumed to be made up chiefly of motor elements. The principal points by which the complex cerebral cortex of the mammal's brain may be distinguished from that of the lower animals are summarized as consisting in an increase in the stratification of nerve cells, a development of special nerve-cell types, the insulation of the transmission apparatus by the formation of sheathing for the nerves, and the existence in the cortex itself of a vast projection system representing the entire body.\* The brain weights of the cebus, chimpanzee, and man may be represented, respectively, by the proportion 1 : 10 : 30, the respective surfaces of their cerebral cortices by the ratio 1 : 5 : 17, and the proportional volumes of this part of the brain are related as 1 : 5 : 24; while the actual richness in nerve cells may be expressed in the figures 1 : 8 : 10–100.† Far more detailed studies than any hitherto attempted are desirable if we are to obtain any clear idea of the width of the gulf separating the human from the simian intelligence. The information usually given in response to any query as to this separation is dictated by sentiment rather than reason. The superiority of the higher apes over the lower mammals is probably measured by their elaborate motor equipment, the semi-erect carriage, the capacity for reasoned imitation, the presence of human-like emotions, and an increased capacity for intelligent reactions.‡ The careful analysis of these functions makes it evident, however, that the existence

\* Brodmann, K., "Zur zytohistol. lok. d. mensch. Grosshirnrinde," *M Schr. f. Psych.*, 1903, p. 644.

† Jakob, *Atlas von Tierhirn z. Menschenhirn*, I Teil, p. 30 (Lehmann, Munich, 1911).

‡ Shepherd, W. T., "The Intelligence of the Chimpanzee," *J. Animal Behavior*, 1915, V, p. 391.

of specific functional characteristics is unnecessary to explain the differences between the brain capacity of man and the ape.

Nor should we expect to find specific morphological differences that are in any direct sense the cause of man's intellectual superiority over the anthropoid apes. Neither the increase in the number of convolutions, their greater size nor complexity, will account for the higher brain capacity of the former. The comparison should be made upon a broader basis so as to include a study of micro- as well as macro-scopic characteristics. Estimates indicate that man has in his cerebral cortex at least ten times as many nerve cells as are found in this structure in the orang, which has approximately one billion.

When the cerebral cortex first appears in the animal series it represents a mechanism which is evidently intended to receive impressions coming to it from lower levels, and here there is stored up and elaborated the excessive neural energy which is connected in some way that we do not yet understand with psychologic memory and associated activities. Even before the days of de la Métrie, who frequently referred to the subject (1708-1751), scientists recognized the fact that of all the animals man possessed a brain which was the largest and most convoluted in proportion to its mass, and some attempt had also been made to compare the functions of this organ as represented by fish and birds to those in the human species.

The brain, particularly the part containing the higher centres, of the man of even moderate intelligence is an exceedingly complex organ. This structural complexity is essential to the performance of his duties as a member of a civilized community. Relatively speaking, a long period of time has elapsed and many changes have taken place in the organ from the conditions represented in the brain of his remote ancestor, *Pithecanthropus erectus*, or the still more primitive pre-*Pithecanthropus* with a cranial capacity about 300 cubic centimeters greater than the largest gorilla has to-day.

The earliest human ancestor was doubtless restricted to the practice of one art, while the human being to-day, even the one possessing a very low grade of intelligence, is capable of practising a number of different arts.\* If we measure time by events in human history it is difficult to span in imagination the thousands of years that have elapsed since homo primogenius, living probably in tropical forests, marked the first link in the chain leading up to homo sapiens with greatly increased brain capacity and his much more highly differentiated cerebral cortex. Primitive man, as Migeod suggests, had the family instinct thrust upon him; and to the prolongation of the period in the infant's life during which special care was required may be traced the beginning of the family and social instincts which were destined to play such an important rôle in civilization.

All animals, below the reptiles, are practically entirely devoid of those special cortical mechanisms which greatly increase the capacity for combining and elaborating impulses and impressions transmitted by the sensory tracts to the brain. As a result of this inferior capacity the adjustments in lower animals are far more stereotyped in form than in those having a fully developed cortex. Although the capacity for rapidly performed automatism may be very great, there is a complete inadequacy to meet successfully the difficult situations arising when an individual faces a dilemma in which complex inhibitory mechanisms, including such psychological phenomena as those of choice, become important factors. Animals lower in the scale, devoid of higher brain centres, possess only those activities which are more or less uniform in type and in which individual variations are far less marked than when well developed cerebral hemispheres exist.

In order to understand the nature of the processes either excitatory or inhibitory taking place in the hemispheres of the brain, they should always be considered in relation to the functions of the large ganglia, forming the base of

\* Stuart, Chapin F., *An Introduction to the Study of Social Evolution: the Prehistoric Period* (The Century Co., New York, 1917).

this organ. The great development of the basal ganglia of birds has led a number of investigators to attempt to correlate these special structures with a relatively high functional capacity as shown in the development of responses suggesting a primitive emotional life.

The basal ganglia in the lower as well as in the higher vertebrates play a very important rôle in the mental life, since they supply a large part of the machinery for the instinctive life. All these basic adjustments are active in the primitive states of consciousness. To understand the character of any of these reactions we must realize that the functions of the brain cannot be considered apart from the other activities of the body, and that the control of these basal ganglia is effected not only by the receipt of impressions from still lower centres, but by many physiologic changes, as, for example, those depending on the circulation of the cerebro-spinal fluid with which they are brought into contact.\*

A reference to a few facts in the phylogenetic development of the optic tract—the structural relationships of which to other tracts are fairly well known, and of its connection with the cortical processes—gives some idea of the character of the complexity of organization introduced by the higher brain centres. Fish possess only a relatively simple arrangement; that is to say, eyes, including a retina, optic nerves, and a band of fibres grounded in the basal ganglia without any cortical connection. Birds, on the other hand, have a secondary circuit connecting these ganglia with a relatively complicated mechanism. Unfortunately, as yet, no careful comparative analyses have been made between the reactions of fish and those of birds, which would enable us to determine with some degree of exactitude the essential differences existing between the behavior of these animals in regard to their respective visual capacities. In a very general way it may be said that the phenomena of vision in birds seem to be associated with a more highly developed capacity for inhibiting as well as

\* Heyne, A., *Neurol. Centralblatt*, 1911, nos. 22-24.

imitating, processes which enable them to exercise a greater degree of choice when their optic centres are stimulated. To what extent this is true for other cortical mechanisms it is at present impossible to say. We know that birds such as hawks, owls, and eagles show intelligence in building nests, and a considerable capacity for adapting these structures to meet changing conditions of environment. To what extent these visual mechanisms are related to other and more complicated adjustments is still an open question. In certain species of birds, probably as the result of still greater elaboration of the cortical mechanisms, the family instinct attains a relatively high degree of development, and the parental care is continued during the helpless period of infancy. In some cases mating is permanent, and there are examples of monogamous unions. The importance of the more complicated cerebral mechanism is suggested by the capacity possessed by the young of certain birds for learning from their elders. In addition to the family life, there are other social relationships indicated by the tendency to segregate into flocks or groups. Similar phenomena, however, have been observed among fish, and, even lower down, in the invertebrates. The possibility, however, of communication between birds deserves consideration, although we do not know the exact means used in bringing this about.

Bechterew\* draws an interesting comparison between the behavior of birds and mammals from whom the cerebral hemispheres had been removed. In the higher forms of mammals in which this operation had been performed there was an inability to maintain the upright position, although the subject still retained the capacity for co-ordinating movements concerned in locomotion. These animals also maintained a passive attitude when their limbs were placed in unusual positions. They were blind and deaf in contrast to the birds, the latter retaining some slight capacity to modify movements in response to both optic and acoustic stimuli.

\* Bechterew, *Die Funktionen d. Nerven-Centra.*, Bd. 2 (Gustav Fischer, Jena, 1909).

In frogs subjected to a similar operation the relative independence of the lower brain centres, namely the sub-cortical ganglia, was greater, a fact which seems to indicate a higher degree of dominance of the hemispheres in controlling the more complicated forms of adjustment, as we ascend in the scale of animal life. As one result of the classical experiment of Goltz, who succeeded in removing from a dog the entire cerebral cortex, it was noted that the vegetative functions seemed to be entirely independent of cortical control. Hitzig accepted the old doctrine that in the subconscious regions of the brain mechanisms were represented that were related not only to the coarser muscular movements, but in this area sensory impulses were also transformed and elaborated into important elements in feelings. Other investigators\* believe that certain observations point to the participation of the lower or thalamic centres in the conscious processes, a primitive or thalamic consciousness quite distinct from the higher forms of self-consciousness under cortical control. This elementary form of conscious adjustment is thought to be non-discriminative and is composed of visceral, thermic, and contact stimuli of great importance in affective reactions, including those stimuli evoking pleasure or discomfort, or consciousness of change in state.†

The elaborate functions of the cortex, in case of injury, may to some extent be replaced by those of the lower centres; the degree to which this functional readjustment takes place is inversely proportional to the position in the scale of development and the age of the animal operated upon. The higher the animal in the scale of development, the less is the chance that the lower basal centres of the brain will assume and continue any of the functions of the injured cerebral cortex. Recent investigations in comparative neurology‡ all tend to show the delegation to and the centralization in higher and central organs of mechanisms that

\* Head, H., & Holmes, G., "Sensory Disturbances from Central Lesions," *Brain*, 1911, XXXIV, pp. 102-154.

† Rivers, W. H. R., *opus cit.*

‡ Vincent, Stella B., "The Function of the Vibrissæ in the Behavior of the White Rat," *Behavior Monographs*, edited by John B. Watson, vol. I, no. 5.

are more widely distributed in animals possessing the segmental type of nervous system. The cortical influence, beginning with animals in which the segmental control is relatively complete, becomes more and more dominant until man is reached and in his case it becomes pre-eminent.

It is interesting to note that the cerebral cortex in the young rat has attained its maximum thickness as early as

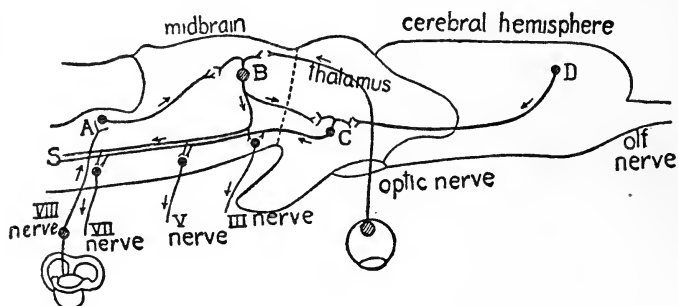

the twentieth day, just before the animal is weaned. Assuming that the growth rate of the rat to man is as 30-1, and that the human brain at birth represents a stage of development corresponding with that of the rat at five days, then we are safe in saying that the human cortex reaches its full thickness at about the fifteenth month.\*

In the figure reproduced in the text† there is a diagrammatic representation of the simple mechanism of association between the ear and the muscles concerned in moving the eye. This path indicates the lines followed by an auditory stimulus, with the associated movement of the eyeball. The increasing complexity of the mechanism occurring when the individual faces a dilemma, where the element of choice enters, is shown in the chart on this page, which represents a longitudinal section through the brain of a mud-puppy. An incoming stimulus passing upward through the spinal cord may reach station *B* in the midbrain, whence it may be

\* Sugita, N., *J. Comp. Neurol.*, XXVIII, p. 495.

† Herrick, J., *Introduction to Neurology*, p. 63 (W. B. Saunders Co., Philadelphia, 1916). By permission.



deflected downward toward the point *A*, or upward and outward along the optic nerve; or passing in quite another direction up to a still higher centre *C*, it may here be brought into contact with the downward flow of impulses from the cerebral hemispheres. This diagram is introduced for the purpose of showing the great possibility of the inhibition of impulses taking place in connection with the development of the higher centres. Tilney has called attention to the remarkable manner in which mechanisms have been evolved for preserving the original automatic movements for executing primitive purposes; but at the same time these are dominated by higher motor complexes permitting greater plasticity and independence. The mechanism determining inhibition, the influx of stimuli which suspend or arrest function, will be considered in a later chapter.

In the general plan of structure of the cerebral hemisphere one or two points of special interest may be noted. In the first place, these structures possess paths by which they are connected with other parts of the nervous system and remote portions of the body; but, of equal importance, if we are to understand their functions, is the existence of the vast intrinsic mechanisms, nerve cells and fibres, by means of which the whole apparatus is transformed into a functional unit.

Since the days of Gall and Spurzheim, the idea of localization of functions in circumscribed areas of the cortex has gradually developed, until it has become one of the prominent subjects of discussion in the study of the nervous system. The usual conception that certain functions are more or less sharply isolated within certain circumscribed areas depends upon data derived from three separate sources. First in the order of historical development we have those ideas which have come to us from pathology. The facts derived from the study of diseased conditions taught physicians that the existence of focal areas in which the function of nerve cells or of fibres have been interfered with often gave rise to circumscribed or localized functional disturbances. Later by experimentation it was shown that if

certain areas were directly stimulated by means of an electric current, movement in certain groups of muscles followed. Finally, as the result of anatomic investigation it became known that the different centres in the brain showed, as has already been indicated, actual differences in the arrangement and distribution of the elements in the nervous tissues. These facts have had various interpretations.

On the one hand are observers who carry the doctrine of cerebral localization to an extreme, whereas others almost entirely disregard the significance of the facts observed and consider the activity of the brain as the result of general, not local, processes. Some authorities regard the centres as areas of increased vulnerability, but altogether lacking in capacity for great independent activity.\* On the other hand there are those who attribute to the differences in structural conditions a high degree of local dependence. Attention has been directed to the fact that, although the cell forms and layers may be approximately similar, there is an extraordinary difference in the number and arrangement of small nerve cells in certain areas as compared with others; and this condition alone is believed to be sufficient to account for specific variations in the mechanism. Some observers also affirm that the topographic relation of the elements in the periphery of the body plays an important part in sense-perceptions directly determining the character of the mechanisms of the cerebral cortex.† According to this view there is a combination of different stimuli into functional units which are determined by the preservation of the order and arrangement of the peripheral stimuli in combinations, the result of structural conditions. This conception is favorable to the supposition that the mental processes are syntheses of hypothetic psychologic units. This view, probably not correct, stands in marked contrast with the position maintained by Herrick, Meyer, and others, in which the reaction of the organism is studied as a biologic

\* Von Monakow, C., *Ueber Lokalisation der Hirnfunktionen* (Verlag von J. F. Bergmann, Wiesbaden, 1910).

† Von Niessl-Mayendorf, *Zeitschr. f. allgemein. Physiol.*, XIV.

unit. According to the first hypothesis the idea of specificity of function is carried to an extreme, and apperception is identical with memory picture or representation, depending upon the direction in which the stimulus flows either from the periphery or from one cortical area to another; becoming either a vivid sense-impression or a faint memory. According to this same theory association mechanisms are formed in the cerebral hemispheres. Broadbent\* believed the cortical termination of the sensory tracts were to be regarded as centres in which representation or formation of percepts actually took place.

The larger portion of the surface of the brain corresponds to the so-called "silent areas" which have no direct connection with the periphery or with the tracts conveying the sense-impressions. The silent areas are, however, indirectly connected with these latter areas by means of innumerable nerve tracts or fibres, and are supposed by some investigators to represent portions of the brain immediately concerned in mechanisms which really determine the so-called content of consciousness. These particular areas are also regarded as having a very close relationship to the emotional life, furnishing the structural basis by which the physical correlates of the feelings are expressed. These reactions expressed in the emotional life develop out of the primitive muscular movements concerned in offense and defense, and responses, such as the contractions of the striated and unstriated muscles of various organs including the blood-vessels, may give rise to complex states of excitation or inhibition.

The defense reactions of organisms are conditioned first by perception and then by the recognition of the action of injurious agents. The first stage in a protective reaction is often marked by the inhibition of a process which may injuriously affect the organism. Not only in general structural character are the "silent areas different" from the motor or sensory portions of the brain, but in their blood

\* Broadbent, *On the Cerebral Mechanisms of Speech and Thought*, trans. Roy. Med.-Chir. Soc., 1872.

supply also. According to one hypothesis the entrance into the brain of stimuli from the surface of the body causes a hyperæmia at one centre, and then reflexly, as the result of special nervous mechanisms controlling the vascular system may cause a diminished blood supply in the so-called association areas. Thus a complex form of mechanisms is introduced which is capable of modifying the general type of reaction. The nerve cells during a reaction are supposed by von Niessl-Mayendorf to be in a state of hyperæmia at one area, while those in which the oxygen supply is reduced are strangled; but although this explanation is ingenious it is conjectural. As a matter of fact many of the ideas entertained in regard to such extreme specialization and localization of function in the cortex represent very crude notions as to the actual conditions of the brain. Probably it is true that the idea of strict and narrow localization is only applicable to a very few of the more elementary functions, such as reflexes. It is evident that only such processes as the direct stimulation of sense-organs and the points of innervations for different groups of muscles can be definitely localized within circumscribed areas; but as soon as the integration begins or the synthesis of these elementary components occurs the processes extend so as to include comparatively large areas of the cortex.

Recently the suggestion has been made (Bolton, Campbell) that the former conceptions in regard to the localization of function in the brain, which were based merely on a narrow interpretation of anatomic data, should be revised to include a broader view based upon a division of the cortex into two parts: (1) a region represented by the large and small pyramidal cells as well as the multiform and spindle elements with direct connection with the projection and long association nerve tracts; and (2) a portion made up largely of the less differentiated cells, including the stratum moleculans down to the beginning of the middle molecular layer representing the cortico-associative system proper. The localization of function in the anatomic-physiologic sense would be confined to the fourth and sixth layers. In

these layers there are shown, but not within sharply differentiated limits, fibre tracts which link the higher with lower parts of the nervous system, especially those uniting definite areas of the body and sense-organs; whereas in the outer cortical layers are the mechanisms for receiving stimuli (proprioceptors) as far as they are "conditioned by their cerebellar, mesencephalic and spinal components." The inner layer has been designated the expressional sphere, because it is assumed to be more directly connected with the output of energy and its representation in effort, thought, word, and act; while the outer one is believed to be largely given over to the receipt of impressions impinging on the body, and is therefore called the impressional sphere.

The psychological analysis of the so-called "pure motor-impulses" indicates that even these comparatively simple responses are fringed with an emotional content which predicates the functional activity of cortical or sub-cortical mechanisms outside of the motor area. The supposition that specific functions are limited to sharply circumscribed areas quite independently of other parts of the brain is an hypothesis which is not confirmed by the data from physiological investigations. The fact that all sensations, as we experience them, are not colorless but have fringes of feeling bordering them, seems to indicate that even in relatively simple psychologic phenomena there exists an associated activity of a considerable portion of the cerebral hemisphere.

Discussions as to the localization of functions in the brain have been conducted to a large extent with the object of meeting the demands of clinicians seeking to establish relationships as definite as possible between structure and function. This point of view is as limited as the one held by those opportunists who formulate a theory of psychophysical parallelism which assumes that mind and body relationships run along parallel without any demonstrable causal connection. Such a working hypothesis emphasizes all points which seem to be favorable while discarding others incompatible with the belief.

Architectonic differences correspond only roughly to the

functional divisions. When we consider the intricate relations existing between all the various mechanisms even in the case of a very simple form of functional activity, it is apparent that our efforts to make brain physiology a simple study must not entail loss of vision as to the real difficulties of the situation.\*

Experimentation has also clearly shown that many of the older and conventional ideas in regard to localization have needed thorough revision and extension. Even the ideas currently entertained in regard to the localization of motor functions have been modified. Franz has demonstrated to what extent the disturbances in locomotion in monkeys induced by the excision of "motor areas" from the cerebral cortex, disappear after relatively short periods.†

At various times the "localizationists" have gone to the extreme of affirming that the frontal lobes are the anatomic "seat of the attention"; and a comparison of the frontal centres in different animals suggested some of the reasons for this view. According to the comparison, in man the frontal region of the cortex occupies 29 per cent of the total cortical area, 16.9 per cent in the gorilla, 11.3 per cent in the gibbon, 6.8 per cent in the dog, and 2.2 per cent in the rabbit.‡ General biologic functions cannot be so definitely restricted without distortion of the facts, and by dogmatic statements we create an imaginary physiology, thus making it impossible to study the problems of the attention in their proper setting. Even the evidence derived from the clinical study of patients now seems to be altogether incompatible with a strict interpretation of "the theory of localization." In the phenomena of diaschisis occurring in connection with an apoplectic injury there is apt to be a very general disturbance of function including consciousness,

\* "The Physiology of the Post- and Pre-Central and Parietal Convulsions," editorial, *Lancet*, 1917, p. 925.

† Franz, S. I., "On Cerebral Motor Control: the Recovery from Experimentally Produced Hemiplegia," *Psychobiology*, 1917, I, no. 1; Minkowski, M., *Correspond. Blatt-Schweiz. Artz.*, March 24, 1917.

‡ Brodmann, *Neue Ergebnisse über die vergleichende histol. Lokalisation d. Grosshirnrinde mit besonderer Berücksichtigung des Stirnhirns* (Fischer, Jena, 1912).

and this is evidence of the wide-spread reverberation taking place in processes that upon casual examination seem to suggest a very restricted localization.\*

Many variations of the localization hypothesis have been suggested. Some investigators believe there are advantages to be derived from such a provisional division of cerebral functions as that mentioned earlier in this chapter, based largely on hypothetical considerations and dividing all the psychocerebral mechanisms into (1) impressionable and (2) expressionable forms. In considering any of the cerebral mechanisms it is well to keep the fact very clearly before our minds that those which at first sight seem to be widely different do not have any specific distinguishing characteristics. It is preferable to accept a still broader division of functions, and to distinguish on the one hand the biopsychic energy which finds expression in the various general mechanisms of adjustment, and upon the other the more specialized forms represented by the phenomena of conscious activity which for convenience of description may be designated as cerebropsychic, or psychic biotonus. This latter is controlled and regulated to an astonishing degree by mechanisms lying far below the cerebral cortex. In this connection speculation is of interest as to the precise part the cerebral cortex takes in the higher form of adjustment represented by the conscious life. While it is true that these newer and more elaborated centres select and co-ordinate the different components of the reactions, that they conceal the appearances of purely mechanical responses and introduce many possibilities of variation which prevent the prediction of the final outcome,† it is nevertheless not the cortex alone that is directly related to consciousness, but all the centres of the several levels have an important bearing upon this particular function.

Dewey and Baldwin should be given credit for calling attention to the reasons for studying the reactions as units.

\* Von Monakow, C., *opus cit.*

† Brown, T. G., "Speculations on the Working of the Brain," *Mind*, 1917, N. S., p. 53.

Herrick has shown the advisability of applying these same biologic principles to the study of the higher functions of the nervous system, including those of the cerebral cortex, and reminds us that the functional activities of the cortex do not represent "simple sensory impressions, but include definitely organized systems of neural discharge, each of which is a physiologic resultant of reflexes, automatisms, impulses and inhibitions characteristic of its subcortical centres."\* The analogy he draws similar to the one used years ago by Hughlings Jackson† between the functions of the cerebral cortex and that of an upper house of Parliament, with restricted powers of initiating legislation, but with the capacity to advise, amplify, or veto bills sent up from the lower house, is an excellent illustration. The instinctive intelligent activities of human individuals depend to a large extent upon the co-ordinating and synthesizing capacity of the cerebral cortex.

Considerable light has been thrown upon the service of the cerebral cortex in the human being by the report of a remarkable case in which an infant lived a vegetative existence, attaining the age of  $3\frac{3}{4}$  years in spite of the fact that the brain was practically without any cerebral hemispheres; only the ganglia forming the base of the brain being intact. The infant was able to suck, and very occasionally emitted low inarticulate tones, but most of the time was asleep, or rather in a stuporous condition. Bright light flashed upon the eyes produced no result except a slight reflex contraction of the muscles concerned in closing the eyes. The occasional monotonous wailing sounds ceased whenever the top of the head was gently rubbed. The legs and arms were motionless, and apart from the "simple reactions the infant was incapable of sensing or reacting. On superficial examination the cortex seemed well-formed, but on inspection it was evident that the nerve tissue had been destroyed by the development of a huge, cyst-like

\* "The Reflex Arc Concept in Psychology," *Psych. Rev.*, 1893, III, p. 357; also *J. Philos. Psych. and Sci. Methods*, 1912, IX, pp. 664-668.

† The Croonian Lectures, 1834.



structure."\* Physiologically considered, this infant was lower in the scale than the dog from which Golz removed the cerebral hemispheres and showed less capacity than was exhibited by the decerebrated frog. The instance of a goat has been recorded in which practically all of the cerebrum was destroyed by the presence of a tumor; and yet in spite of the loss of these higher brain centres the animal was able to stand and walk; and food placed in the mouth was swallowed in quite a normal manner.

We have to be extremely careful in drawing deductions about cortical functions from observations conducted on different species of animals. Homologous organs, or parts of organs, do not have the same physiologic value in every animal. The process of decerebration of the dog is followed by far less striking results than the operation would be if practised upon higher animals such as apes. Recent experiments upon the effects of the removal of the cerebral hemispheres in apes have been successfully made, but our present superficial knowledge of the functions of the cortex renders the comparison between the decerebrated dog and ape less significant than was anticipated.† Deprived of these higher centres apes are still able to execute a number of movements, although it is noteworthy that the same movement once made tended to recur a number of times in succession. They were still able to make definite sounds resembling cries, responded promptly to touch stimuli, but showed no adaptation of movement to the special form of stimulation employed; in other words, there was a marked diminution, if not complete loss, of the ability to discriminate. The results of the observations tend to show that the higher we ascend the scale of animal life the greater is the tendency to centralize the most complicated activities within the dominant control of the cerebral cortex. The autonomy often displayed in activities of animals that have not attained the complex development of the human being

\* Edinger, L., & Fischer, B., "Ein Mensch ohne Grosshirn," *Arch. f. d. Ges. Phys.*, 1916, CLII, p. 535.

† Karplus, J. P., and Kreidl, A., *Arch. f. Anat. u. Physiol.*, 1914, p. 155.

is in the latter case replaced by a centralized control that scarcely permits any independent responses of subordinate centres when there is any serious interference with the upper controlling levels.

This is hardly the place to enter upon a detailed discussion of the various opinions as to the functions of the different parts of the brain, but we cannot omit all reference to Flechsig's teachings in which he tried to establish a very intimate relation between the anatomic conditions and the cerebral functions, especially those supposedly indicative of the higher forms of mental activity. Flechsig's observations inclined him to think that the ripening of nerves preparatory to beginning the discharge of function was closely connected with the growth of the medullary sheath, and furthermore that all nerves with closely allied functions were developed about the same time. Proceeding from this assumption, and purely from deductions drawn from anatomic investigation, he believed that numbers of different centres with specific functional values were blocked out on the surface of the brain. But later more thorough investigation has practically proved that the only areas for which this supposition holds true are for the sensory and motor regions. Flechsig's conception of localization, being unfortunately limited, led to a number of incorrect deductions. Other investigators have warned us that because the maintenance of the proper tonus of a certain part of the brain's surface is essential to insure reactions in connection with a particular nerve tract is no proof that the consciousness of what has happened is restricted to a comparatively small area. C. L. Herrick's view-point is helpful in this connection, and is an elaboration of Semon's ideas to which reference was made in the preceding chapter. He suggested that, instead of thinking of the brain in terms of a narrow localization of areas and responses, we should regard the entire organism as sharing in the general tonus of the whole body. The equilibrium of the psychic biotonus is disturbed by various stimuli, and consequently it is shifted from one to another group of adjustments. When a given centre appears to be

unusually active it is because the whole equilibrium has been disturbed by the sudden shifting from a given area of a predominant amount of energy into the general current. Consciousness, according to Herrick, marks the fluctuations in the equilibrium.

There seems no evidence that warrants the attribution of any specific form of psychic activity to the cerebral cortex. This organ is controlled and regulated by lower centres, localized by some investigators as at the base of the brain within the structures of the optic thalamus. The degree of cerebral tonicity necessary for consciousness is undoubtedly maintained by the reciprocal activities of all the centres. Although it is probably a mistake to try to locate these regulatory centres within any one part of the brain, it is certain that the complicated masses of nerve cells and fibres in the basic region have an important influence upon the cortical responses. A number of facts seem to indicate that the "kick-back" from the lower centres is a strong element in inciting to activity and possibly also in restraining the cortical mechanisms.

An acquaintance with the facts known about the nerve tracts for conducting to the cerebral cortex impressions made upon the external sense-organs enables us to form some idea of the relative value of reciprocal connections between the lower areas in the spinal cord, the intermediate stations in the basal portions of the brain, and the highest centres in its external gray substance. Also observations upon some of the anatomic relations, especially those designated as carriers of sensory impressions, have thrown light upon the provision evidently intended to facilitate discriminative distinctions of function. The nerves conveying incoming stimuli from the various sense-organs, after entering the spinal cord, its posterior columns, have a more complex arrangement and distribution than have those tracts conducting the outgoing motor impulses from the brain to the muscles. Nerves transmitting the stimuli that give rise to the recognition of postural position and spatial discrimination run up through the cord, keeping to

the side upon which they entered; whereas those carrying impressions of contact, touch, and pressure are contained in the columns on both sides of the cord. At terminal stations situated at the upper end of the cord relay tracts are introduced for the purpose of transmitting the impulses to the basal ganglia situated in the optic thalamus of the brain—the essential organ of the thalamus.\* We need not enter further into details of the microscopic structure, except to mention the five distinct groups of conducting lines that may be observed in this region: those related to functions concerned in (1) the recognition of pressure, passive movement, and discrimination of weights; (2) tactile sensation; (3) spatial discrimination; (4) the capacity to localize the situation of stimulated spots on the body; and, finally, (5) in distinguishing heat and cold. We know that one function of the cortex is to fabricate the material supplied by these lower centres and to bring one sensation into relation with others; but it also seems probable that the thalamic region or great intermediary station has much to do with the affective side of the sensory reactions, and has a distinct part to play in responding to stimuli capable of “evoking either pleasure or discomfort, or a consciousness of a change in state.”

An analysis of the mechanisms providing prompt and efficient control of movement demonstrates the significance of the work of the subsidiary centres in the processes of integration, processes often although not always initiated by the cerebral cortex. In the efficient control of movement the cortex is of great service by its discharge of impulse along the spinal motor tracts, the pyramidal system, to the various muscles concerned in locomotion, and the movements of the limbs and trunk. The normal tonus of the muscles must be maintained to secure an effective response when they are called into activity. A double nerve supply is necessary to effect this: one representing a direct line of

\* Brown, T. G., and Stewart, R. M., “On Disturbances of the Localization and Discrimination of Sensations in Cases of Cerebral Lesions,” *Brain*, 1916, XXXIX, p. 348.

communication with the cortex and the other connecting the muscles with the sympathetic system, the former being responsible for the quick response and the latter for the slower contraction of a very different element in the muscular tissue.\* The regulation and control of the movements are effected through the activity of still another system of nerves coming from the great striate bodies at the base of the brain; these seem to supply the inhibitory and co-ordinating influences essential in all well-regulated movements. The genesis of this complicated extra-pyramidal or pallidal system, as it appears in man, may be traced back to relatively very simple structures found in the fish. The extraordinarily complex arrangements provided for the carrying out of the extremely well co-ordinated movements in man, are another bit of evidence emphasizing the importance of the muscular system in preparing the basis for adjustments at the highest conscious levels.

The degree of adaptability characterizing the activities in man as compared with the lower animals is the result of the elevation of function from the field of "necessary reactions to educable adaptations," a transformation made possible by the superimposed higher centres of the cerebral cortex. Gradually in the course of evolution, because of synthetic and inhibitory modifications, the higher centres became less and less immediately dependent upon the lower ones, until in man we find a series of mechanisms within which are located the major part of the controlling if not initiating elements regulating all conscious experience.

Man's supremacy over the rest of the animal world depends upon the addition to his adjusting mechanism of the new parts recognized as the cerebral cortex. Its function is to extend the range of successful adaptations by modification and inhibition, and so direct the stream of nervous energy along paths mapped out and determined by individual experience. Those who have carefully observed the

\* Hunt, J. Ramsay, "The Efferent Pallidal System of the Corpus Striatum. A Consideration of Its Functions and Symptomatology," *J. Nerv. & Ment. Dis.*, 1917, XLVI, p. 211.

reactions of the higher apes tell us\* that the mental life of the infrahuman primates should be more accurately investigated since an increased knowledge of the cerebral mechanisms of monkeys and apes might very possibly throw a flood of light upon fundamental human instincts and habit-formations, and so lay the foundation for a comprehensive understanding of human life. Comparison of the cerebral cortices of man and the orang-outang demonstrates such great difference in structure and complexity that it is not surprising that the ideational life of the latter is far poorer than the former. On the other hand, the versatility of the ape when dealing with situations demanding the recollection of experience is so great that it is difficult to disprove either the existence of free ideas or of the reasoning process. Before the higher forms of apes shall have disappeared from the earth, it is to be hoped that there may be afforded adequate opportunity to study them in order to make fuller comparison of their behavior with that of human beings.

But even in our present state of incomplete knowledge we are impressed again and again with one fact—namely, that in trying to trace the continuity of activities which bring man into relation with the lower animals, we are unable to find on the intellectual side any point marking the place where the primitive impulses and simpler responses are carried over into the world of ideas, or any suggestion of the introduction of specific elements indicating an inseparable gulf between man and beast.† Undoubtedly more light would be cast on the functional importance of the higher brain centres if additional information could be obtained about the mental traits possessed by some of the transitional types differentiating man from the anthropoid apes. The appearance of human beings capable of consid-

\* Watson, J. B., "The Need of an Experimental Station for the Study of Certain Problems in Human Behavior," *Psychol. Bull.* no. 3, p. 149; Yerkes, R. M., "The Mental Life of Monkeys and Apes," *Behavior Mon.*, 1916, III, no. 1; Montane, L. A., "Cuban Chimpanzee," *Animal Behavior*, 1916, VI, no. 4.

† Chapin, F. S., *An Introduction to the Study of Social Evolution* (The Century Co., N. Y., 1913).

erable intellectual activity, descendants of the primitive men of the old Stone Age, is, as Osborn states, "one of the great mysteries of psychology and history."\*

In the figure on page 61 there are given the outlines of the brains of the chimpanzee, the Piltown man, and the modern civilized man. The different stages of development in the brains of homo alalus and homo sapiens may be easily recognized. It is not so much in its volume as in the outline of its form and organization that the superiority of the last of the three brains is evident. It possesses a greater fulness in the frontal region and in the areas connected with the motor-speech apparatus. Future discoveries, we hope, may provide new material from which to make fuller deductions as to the brain capacity and the mentality of the early primitive races of man.

There is still another phase of cortical functions in which we all have a keen interest; we refer to those exhibitions of transcendent ability which are marked and to explain which we have often tried to trace their close connection with the facts as they are known regarding the general functions of the cerebral cortex. But only in a very general sense are we justified in the present state of our knowledge in trying to correlate the structure of these higher brain centres with those expressions of "brain power" of such high order that they seem inexplicable by any of the known laws of physiology. The question is often asked as to whether it is possible in studying the structure and functions of the brain to find any clue that may sometime lead to a possible physiologic explanation of the accomplishments of a Leonardo, Shakespeare, or Beethoven. Here again the attack upon the problem should be from the broad biologic and not from the narrow neurologic point of view. A complete and therefore satisfactory explanation should not be looked for in the results of a restricted study of the brain and its functions; but in the comprehensive analysis of all the biologic reactions of the individual. Many of the special mechanisms

\* Osborn, H. F., *Men of the Old Stone Age* (Charles Scribner's Sons, N. Y., 1916).

determining the characteristic reactions and thought processes of a genius may probably be found in the organs lying outside of the nervous system. The attempts hitherto made to associate genius with abnormal mentality and insanity, or to interpret the phenomenon by reference to the hypothetical dominance of this or that particular function of the brain represent very crude efforts to solve a great problem.

In instances when a careful analysis has been made of the mental mechanisms of men of great ability, followed by a consideration of functional activities in relation to the structure of the brain of the individual, there has often been sufficient evidence to justify at least a superficial correlation between the structure and a high degree of mentality. Investigators have succeeded in making it clear that there is a general relationship between great intellectual attainments and a noteworthy development of the frontal lobes of the brain; but it is scarcely advisable to expend too much effort in formulating a concept of isolated functions supposed to be strictly localized in certain sharply circumscribed areas, since such conceptions are likely to be but repetitions of the erroneous ideas in Gall's phrenology.

The actual weight or size of the brain is not indicative of "the brain power," since many persons with large brains possess only a low degree of mentality, and the man of genius has sometimes only a comparatively small cerebrum. Furthermore, complexity of structure is not always shown by an increase in weight of the brain. As related to this question, it is worth noting that recent investigations would seem to confirm the impression of the relative inferiority of the brain of the negro as compared with the Caucasian. This has long been discussed by anatomists with varying opinions as to the results of the comparative studies, but quite recently new light thrown upon the problem seems to have produced more specific evidence that there is a fairly constant variation of the negro brain from types demonstrated by the study of a large number of Caucasian brains; and, although the negro brain does not present any single



morphologic features that may be designated as specific, there is, nevertheless, a well-recognized deviation from the general plan of the brain of the white man. Moreover, the structural characteristics of the negro brain show it as an organ less complex than that of the white race.\* This is evident in the imperfect development of the interior association area, the narrowing of the convolutions, the inequality of the gyri, a relatively low average of the brain weight, and less complexity in the arrangement of the fissures.

Although the study of the convolutions of the cerebral hemisphere undoubtedly has some value as an indication of the mentality of a person, we should, nevertheless, avoid the tendency to overestimate the importance of anatomic conditions. The arrangement and structure of these are not the result of mere chance, but are indicative of the complexity of the developmental processes. But if the convolutions, together with the weight of the brain, are considered in their relationship to other factors, they may be counted as elements of some significance in the scale by which human intelligence may be measured.†

Practically the same conclusion that no single morphological quality may be thought indicative of inferiority has been reached in regard to the brain of the American Indian.‡ The Indian brain in its chief features represents a comparatively high type of cerebrum, although in one or two particulars there are evidences of the persistence of an inferior development. The marked asymmetry of the two hemispheres, however, corresponds in the main with conditions found in practically all the highly specialized brains, which suggests the query as to whether asymmetry is a distinguishing characteristic accompanying greater mental endowment. This lack of correspondence in detail between the two sides of the brain has been demonstrated by comparison of Eu-

\* Poynter, C. W. M., and Keegan, J. J., *J. Comp. Neurol.*, 1915, XXV, p. 183.

† Naecke, P., *Biolog. Centralblatt*, 1911, XXIX, no. 23.

‡ Keegan, J. J., "A Study of a Plains Indian Brain," *J. Comp. Neurol.*, 1916, XXVI, no. 4.

ropean cerebra with types thought decidedly inferior.\* As to special functions such as right-handedness we may state the supposition that there was a decided pre-eminence of the left-arm centre. This belief is somewhat strengthened by the fact that asymmetry is much more marked in man than in the lower animals, and in the more intellectual representatives of the species. More detailed studies are necessary to settle this question, and, as Keegan suggests, valuable data could be obtained by ascertaining whether better vision in the right eye is in any way correlated with a more prominent area striata and sulcus lunatus in the left hemisphere.

The study of special functions in relation to structure informs us of many recorded cases in which great activity along certain lines has been undoubtedly accompanied by very marked development of the frontal lobes. The brains of Gauss and Olivier, both distinguished mathematicians, revealed these characteristics in a high degree. The unusual command of language so pre-eminently characteristic of great orators (Gambetta) is accompanied by a prominence and complexity of both convolutions and fissures in the pars operculum and in a part of the third left frontal convolution, an area within which many of the mnemonic representations connected with speech movements are associated.

Other parts of the brain, particularly those in the neighborhood of the interparietal fissure and the angular gyrus, have been found to indicate unusual complexity of structure in the cerebra of those endowed with great intellectual activity.

In the brains of great artists, either musicians or painters, evidences of special development of certain cortical areas have been noted more often than among other types of genius. Bach's skull, for instance, showed unusual prominence of the portions of the brain about the supra-marginal convolution, and very possibly we should have found in the cases of Beethoven and von Bülow an uncommon degree of

\* Appleton, A. B., "Description of Two Brains of Natives in India," *J. Anat. and Physiol.*, XLIV.

development of the acoustic centres in the temporal region. This same area is doubtless unusually well differentiated in all great musicians. In the case of painters the visual centre and the contiguous portion of the brain become of greater importance, comparatively speaking, than the auditory area; thus Raphael's skull is said by Mingazzini to have shown that those parts of the cortex in which the optic memories are stored were more prominent than ordinarily.\*

The relation of these particular centres to the general functions of the brain and their bearing upon the display of genius is a question that many more facts yet to be acquired must settle. Meanwhile the inference seems justifiable that their activity is of considerable importance, and in the case of poet, musician, and painter their influence may be very great. Verdi, compelled to leave his bed at night to note down melodies that prevented him from sleeping, Goethe dominated by the extraordinary sense-impressions of which he was conscious, and the artist visited by vivid scenes and faces impelling him to transfer them at once to canvas, are all examples of the hyperactivity of special tracts and centres.

Nevertheless sensory impressions represent but a few links in the synthesis of activities that finds its highest expression in the mind of the master. To understand comprehensively the mental mechanisms of great minds we have beside the consideration of their intellectual activities those other factors such as the elaboration of motor-processes, the nature of the emotional reactions, etc., and lastly the process by which the unity of all these adjustments is effected and represented in the final synthesis. We are still a long way off from a true explanation of genius in the terms of physiology, but it is not more difficult nor essentially different from other problems that lead to the consideration of the fundamental forces directing and shaping the trends of human activity.

We have failed to understand genius as it is measured

\* Mingazzini, G., "Der geniale Mensch u. d. Entwicklung d. Hirnmantels," *Neurol. Centralblatt*, 1914.

merely in terms of intellect, but intellect, as we shall presently see, cannot exist independently, since it rests upon an organization of the emotions expressed as sentiments; and these in turn are based upon still lower planes of activity.

An analysis of genius should distinguish between the capacity to add to the store of mental acquirements and the acquirements themselves. If such distinctions are not observed we shall have endless confusion. The additive capacity measures the innate qualities, whereas the acquired or stored up experiences are the product of a series of reactions in which the environment is a prominent factor. Again we would stress the care to be exercised when summing up the qualities distinguishing men of transcendent ability from those of ordinary ability or talent, or in any attempt to make decided contrasts between human and animal intelligence. Nor should we encourage dogmatic statements, since the distinctions in both cases are based as yet upon arbitrary decisions as to which qualities shall be counted in the final test. The different types of genius expressed in the victory of a Napoleon, in the artistic conceptions of a Michael Angelo, or in the scientific discoveries of a Newton indicate the character of the general synthesis of bodily activities. When we are held spellbound by such achievements as theirs we should not forget that the evidences of the lowly origin of man are equally marvellous although more easily ignored.

Before leaving this complicated problem of genius we may admit our small acquaintance with the mechanisms concerned in such a system. There is little use in attempting to trace its genesis as if it were without relation to reflex and automatic activities such as are displayed in instinct, feeling, or sentiment. People may contend that there is no solution to the enigma, and some are even willing to say that the key to it cannot be found. The mind of the master, or genius, whichever designation we choose to apply to so complex a form of adjustment, demands our most thorough analysis. It has been too long studied as a finished product; we need to observe it in the making.

Perfected methods of detecting subtle differences between the various mechanisms will perhaps enable us to follow processes called into action in affecting the final complicated synthesis.

We shall later have occasion to refer to the great number of factors, such as glandular structures, etc., that have a decided influence in extending or limiting the functions of the brain and nervous system by their control over the emotional reactions. It is quite conceivable that the brain of one person may, from the anatomist's view-point, have the structural qualities entitling its possessor to be rated as a genius, and yet the full development of the cerebral functions may be prevented by the hypoactivity or hyperactivity of organs outside the nervous system. The size, weight, and anatomical relation of the parts of the brain of a person having mediocre ability may be identical with those of the organ possessed by a Shakespeare or a Newton, but the functional activities of the moderately endowed person may have been prevented from attaining the extraordinary development shown by these famous men because of the restrictions imposed by the increased or diminished secretions of, for instance, the thyroid gland or adrenal bodies.

In genius as in all other forms of adaptation each mental constituent tends to unite itself with other constituents lower in the chains of activities until all levels have been reached. The final unity represents a system or synthesis which is the expression of the individual's biologic reactions. In the next chapter we shall try to indicate some of the broad biologic lines to be followed to produce any successful analysis of the functions of the cerebral cortex—functions expressed in the phenomena of the human personality.

Many interesting examples might be cited of the striking disregard shown even by investigators of genius to the nature of the activities occurring at the lower levels; such observers have taken into account only those responses described as conscious. Lange, for instance, whose name is closely identified with the study of the emotional life, failed to distinguish between the necessity for the control and

the repression of affective processes, and actually went so far as to state that we may some day meet with the ideal man imagined by Kant to be a product of education, who would be a creature possessing only intelligence, with emotions suppressed to a degree that the residual processes would be considered as "mental troubles little worthy of him." It is scarcely necessary to explain that such a fanciful conception is not based upon any data obtained from the biologic study of human beings. Man's position in the biologic world is conditioned by his complex emotional organization. Even in the anthropoid apes the affective life is centred entirely about the instinct relating to the preservation of the life of the individual, and secondarily in that of the preservation of the species. As we pass from the primitive man on through intermediate stages of life up to the highly civilized type, the emotional reactions are grouped about other instincts and sentiments, and rapidly become better organized and complex. The higher intellectual no less than the volitional processes are integral parts of a system which is based upon the organization of sentiments and emotions.

It is only recently that the brain was recognized as the centre of a great system for the reception, co-ordination, transformation, and distribution of energy. Failure to explain the functions of this organ is to be expected if we insist upon regarding it as unrelated to functions taking place in other parts of the body. The biologists have told us that even in the amœba and jellyfish the responses cannot be reduced merely to the enumeration of the neural reactions, since the activities of the nervous system are in turn modified by various organs. The ability for adaptive response in fish is considerably lower than the range possessed by guinea-pig or mouse. The explanation must be sought for not only in the mechanisms of adjustment, but in the details of general structural arrangement. So the contrast between man in his state of primitive savagery and the increased adaptiveness of the intellectual classes in civilized nations cannot be dismissed merely as the result of

increased brain power. The habits of life essential to adaptation either in civilized community or in Terra del Fuego and the tropical forests of New Guinea gave rise to structural peculiarities in various organs not in any sense specific, and these changes, not inherited, serve to influence the distribution and transformation of energy by the nervous system.

## CHAPTER IV

### THE PERSONALITY

IN the preceding chapters we have pointed out some of the reactions, reflexes, automatic and volitional responses, that, viewed as an aggregate, are characteristic of every human being. These responses considered in relation to the individual's general physical qualities are collectively designated as the personality; judged in relation to conventionalized and standardized situations, social customs, and morals they are described as character.\* The ensemble suggests both stability and progression, making a man "what he is, or marking him off for all that he is not." From the very beginning of any study of some one person, a complex, difficult to define, forces itself upon the attention of the examiner; and this apparently indefinable complex we sum up as the personality. The personality expresses a series of relationships—to self, race, and sex. Among the first to develop are those marking the individuality and self, then come those connected with the herd instinct and membership in the group, and finally, and of equal importance, those described under the more or less indefinite name of sexual.

In studying a personality the final estimate is based upon the consideration of the characteristics or standards common to human beings.† The idea of the personality is an organismal conception, and expresses the functioning of the machine as a whole; the summing up of character. In studying a personality the functions of the different parts of the machine often are considered, but the final estimate of the personality is made, not with the object of deciding upon the efficiency of any organ or even groups of organs, nor with the purpose of measuring the strength of instincts,

\* Watson, J. B., *opus cit.*

† Warren, H. C., *Human Psychology* (Houghton, Mifflin Company, 1920).



power of emotions, nor degree of intellectuality, but in order to give a general idea of how a person reacts to his or her environment and also what the behavior may be under different conditions. Character is a less comprehensive term than personality, and refers to those special aspects of the mental and emotional adjustments that are distinctive of a person's standardized or well-organized social relations. The personality includes two distinct groups of functions: the judicial, deciding, selecting processes collectively described as intelligence, and the energizing, emotivating, driving powers called character. As Fernald has pointed out, the former give direction, and the latter supply the drive to the adjusting processes.

The personality is at the same time both simple and complex, depending altogether upon our methods of studying it. It seems so extremely simple as expressed in some definite action of daily life. I sit at the desk and write, or I rise and walk about the room. The use of "I" is a sign of recognition of the personality, and may or may not be accompanied by some realization of the complexity of the problem also. Perhaps a bump on the head, a sudden faint spell, or a derangement of the internal organs may give me an inkling of the extraordinary complexity of this "I"; or a change in environment and the cropping up of new and unexpected occurrences may suddenly wipe away the veneer imposed by civilization in the shape of conventional reactions, and thereupon another phase of the personality, with all its barbaric, primitive instincts, recalling a very remote past, is exposed.

From this illustration it is evident that a complete examination of a personality would cover not only the life history of a person, but would also include a description of ancestral traits and experiences. The personality may well be compared to the effect produced in music by striking innumerable chords. These chords in the personality reproduce both individual experiences and those stretching away into a dim, distant past.\*

\* Fuller, Bampfylde, *Man as He Is* (Stokes & Co., N. Y., 1917).

Every human being, from the lowest to the highest types, represents the systematized activities of an agglomeration of organs, and the nature of their relation expressed as a whole is the factor that gives distinguishing characteristics of personality to each individual. The basic mechanisms of people are about the same in all parts of the world, and hence from one point of view the fundamental character of the mechanisms concerned in the growth of the personality is probably not very different in individuals of different races, although in a measure modified by environment.

We may compare roughly the methods used in judging a personality to that employed in deciding about the running capacity of a motor-car. First we get a general impression of the car and then consider the details of the motor and various other parts. Having observed the car at rest we ask to see what it can do in action, whether it rides easily on a level, and whether it has a good hill-climbing capacity. The interrelation of the various parts is noted, but in addition to these observations the reputation of the firm that made the car is also taken into account, in passing judgment on its general use and efficiency.

Every personality represents the accumulated deposits of history. We cannot be reminded too often of the fact that this aggregate of reactions contains many that may be traced back to the amœba, and even in the higher levels of adjustment, which we delight to believe represent emancipated activities, there are signs of the lowly origin of man, bonds uniting the personality of this century with proto-man or his Cro-Magnon ancestor. Although wise in his own concept, boastfully presumptuous of what he loves to describe as his capacity for rational thought and ability in purposefully applying means to attain some progressive end, he is apt to forget how easily the unity of the personality may be destroyed, quickly exposing the repressed primitive, rough-hewn life, full of unconscious reactions, blind impulses, and marked by an almost complete absence of initiative, controlled by herd instincts, irrationalism, animism, and the bondage of rude custom-thought. Even in the so-called

well-rounded personality there are many reminders of those periods in man's early history when what Briffault calls both custom- and power-thought, as opposed to rational thought, are dominant characteristics. In various intellectual conceits no less than in the outburst of primitive emotions we can somewhat approximate the struggle continually going on in every personality, tending to vitiate judgment and limit the range of mental adaptiveness.

Even a casual judgment of any personality involves, to a far greater extent than the average person believes, the consideration of the personality at rest, in action, and in various stages of its evolution. To judge a personality correctly we cannot ignore the influence of qualities inherited from very remote ancestors. A personality that pleases us by expression of interests in general culture, impresses us by decisiveness of action in some great crisis, or arouses astonishment at success in dealing with financial problems, illustrates the changes in the original impulses of the lower animals brought about by the transforming, creative power of cognitive processes. The idea of personality implies the consideration of aptitudes, capacities, and predispositions, but, in addition, the modifications produced in these by the constant change of environment have to be considered, and in dealing with these we are brought face to face with the difficult problems of what may be the result of physiological inheritance and of environment.

A common-sense method of studying the problem of personality begins by noting general traits, physical and mental, and by enumerating some of the chief characteristics of the complex before any detailed analysis of special functions is attempted. For this purpose a certain degree of familiarity with the methods of collecting data in psychobiology is necessary, since the impressions must be intelligently recorded, both to promote accuracy and facilitate research. Much of the present confusion about the study of the personality arises because particular phases of the problem have been attacked without a preliminary general survey.

As we begin our research into the subject of the person-

ality we must not allow ourselves to be influenced by the apodictic statements of that school of philosophers that forbids physiologists from trespassing upon the precincts preempted by academic psychologists. The intimate relations between conscious and subconscious levels of activity emphasize the intimate relations between psychological and physiological processes. The marvellous synthesis of the personality is a product or compromise between the inner biologic needs and, as Alfred Kuttner has phrased it, "the corrective reality of the outer world."

The statements of those who attempt to explain the phenomena of the personality merely by calling in crude mechanistic conceptions are as unconvincing as the opinions of the pronounced mystics. Those who refuse to admit the reality of consciousness arbitrarily limit the discussion of the personality problem to the special phases in which they are interested. As a rule those who deny consciousness have associated the concept with emotional experiences in early life, either when they accepted a mystic philosophy or were associated so intimately with persons who did that a more or less violent reaction against the early environment symbolized by the term consciousness takes place. In other cases emotional reactions of a strong character limit the interest of the investigator to one particular group of problems, so that he fails to take cognizance of other aspects of the problem and unconsciously becomes the self-appointed apostle of what he believes to be the truth. Because of his lack of interest in the problems of consciousness the assumption is made that they do not exist.

For a long time the special interests of psychologist and philosopher in the personality problem occupied attention so exclusively that a good many processes contributing to the complex were forgotten.\* The distorted vision of one-sided views suggests the difficulties of an artist who tries to work out the details of a portrait before the outlines of the figure have been blocked out. Too great familiarity with

\* Haldane, J. S., *Mechanism, Life and Personality* (Dutton & Co., N. Y., 1914).

all the hypotheses suggested to explain the laws governing the personality may be as serious a handicap to the present-day inquirer as encyclopædic information of the geographical speculations of his time would have been to Columbus.

How then may we proceed to study the personality of which we are wont to speak with such assurance? We know that it does not consist of body alone, but of a body that has a capacity to feel, think, and act; or, as Ribot has so clearly put it: "The physical is the basis of the psychological personality." Sensations, ideas, judgments, trends, groups of trends, are complex systems, the integration of which cannot be disturbed without deranging the personality. This synthesis in health depends upon a relatively stable relationship, just as the presence of water calls for the maintenance of a balance between oxygen and hydrogen molecules. While some of the factors may now be enumerated that enter into its composition, we must remember that to trace the complete development of a personality would involve us in a study "of the entire course of human, mental, and social evolution,"\* and our present purpose is merely to suggest lines along which inquiries concerning individual cases may be profitably conducted.

In the restricted psychological sense the personality represents to a large extent, proprio-ceptive forms of experience, although to some people the word itself suggests inaccessibility, sensations, "feelings," innermost thoughts, and does not seem to them to be connected with peripheral mechanisms or with any other kind of activity that can be studied objectively. Yet the proprio-ceptor apparatus, it will be remembered, includes the sense-organs located in joints, tendons, and muscles; and these organs contribute very special information for building up a knowledge of "self" as distinct from other individualities. Few persons in practical life refuse assent to the proposition that important inferences may be drawn from this "self-knowledge," not only in regard to their own body but as to the bodies of

\* Parmelee, Maurice, *The Science of Human Behavior* (Macmillan & Co., New York, 1915).

others. Nevertheless there are some philosophers who contend that the latter deductions are valueless, since information about the body is accessible only to the inhabiting mind. Emotional reactions, not reason, fix this belief firmly in consciousness.

On the other hand, students of the human personality must avoid the bogie known as the "subcutaneous mind," which to the timid may become a threatening spectre. The advocates of the theory of the "subcutaneous mind" are wholly oblivious to the effect of the environment upon the personality. But here we are getting perilously near a field of inquiry that has long been regarded by the speculative philosopher as private property; and we cannot afford to precipitate an argument as to the hypothetical relations of the mental and physical aspects of the personality, since it might carry us away from our present purpose to describe the nature of the integrations represented by the personality. Although we must preserve a wide perspective and include in it a regard for the mind, we shall make better progress if we discuss our behavior problems, as Perry\* has advised, in relation to the elements of the environment that are selected by the behavior; and this includes the consideration of the nature of both stimulus and reaction. Recognition of what our problems include places us in a position to take such precautions as will justify our inferences, both as to our own and other people's behavior.

The mind, Perry informs us, when considered biologically reacts desideratively; and the brain and nervous system localize and condition the range of interests, and determine how much of the environment is to be embraced by the mind. This organization embraces interest, nervous system, and content. Without a grasp of these essentials it is impossible to form an intelligent conception of the personality, which is a collective term for designating a series of complementary reactions. We may begin with the stimulus, follow with reaction, and finally reach the en-

\* Perry, R. B., *Present Philosophical Tendencies* (Longmans, Green & Co., New York and London, 1916).

vironment; or we may reverse the process; but none of these elements must be omitted from the final summing up. The idea I have of myself expresses a conception of identity of experiences both past and future. This process further predicates the ability to look in two directions, forward and backward, while individual limitations of vision depend upon the power to organize experiences and to show their relations to a common basis.

The fully developed personality stands out clearly and presents definite aspects, or "purposes," that define its attitude toward broadly correlated experiences. Man, however, is not conscious of all his life experiences; indeed, at any particular moment he realizes but a relatively small number of them. Yet in comparison with the lower animals he is in touch with enough of them, which extend over a sufficient range of time, to produce in him a sense of permanence and identity of self. While the chimpanzee or orang-outang may have some faint notion of permanence, it is to a very limited degree that the interest in the experiences of life reaches beyond occurrences of the immediate present.

The personalities of to-day register the progress made by man toward greater explicitness and comprehension in dealing with experiences. In the process of evolution the personality represents a purpose carried forward by man from the time when civilization first dawned. If this beginning takes us back 150,000 to 300,000 years, it follows that during only one-fifteenth to one-thirtieth of that time has the development of the personality as we experience that phenomenon become a prominent factor, because only with the rise of modern civilization do the phenomena associated with a civilized personality come plainly into evidence.\* To-day it suggests not only a special person, but recalls the social and racial conditions under which that life has developed.

When we think of a personality we at once connect with it the brain in which the concept is formed, and particularly with those portions of the nervous system in which the higher

\* Hobhouse, L. T., *Mind in Evolution* (Macmillan & Co., New York, 1915).

conception is elaborated. The personality is a diagonal in a parallelogram of forces, and marks the success attained in adjustment. This synthesis can be expressed in another way by saying the personality represents the capacity to avoid certain things or use others in the environment. Hence some parts of the nervous system, depending upon individual traits, are used more than others. Since there is less provision made both in the structure and the function of the nervous system for man to react discriminatively to the process going on within his own body than there is for obtaining reliable information about the environment, these attitudes, according to Weiss, are usually personified as the man within and the man without, and stand in sharp contrast to each other. It is probable that when we understand more about the relationship of these two groups of functions we shall have a clearer idea as to the nature of the responses in the two types of personality represented by the extrovert and introvert. In the former the man without seems to dominate the situation, and the interest in life is being constantly pushed out and extended. This type of personality resembles the passenger quarantined on a ship who is extremely anxious to go ashore and explore his surroundings. In introversion the man within is constantly exercising a restraining function, and this tends to narrow the contacts with the environment. Whereas the former man eagerly comes into touch with the environment, the latter is hampered largely by subconscious impulses and responds to the vague but strongly inhibiting impulses emanating from within. By the careful comparison of these two types it will probably be possible to determine many points of interest relating to the structure of the personality. Many of the phenomena of personality suggest merely a loose synthesis of functions, brought about or focussed, in one part of the brain; but this does not signify that the entire process concerned in these representations and conditions is in any sense completely localized within a comparatively limited area of the nervous system. On the contrary, the adjustments taking place in the higher



levels of activity are regulated and modified by processes going on in many other organs, and in parts of the body separated by wide intervals from this central station for the reception, elaboration, and discharge of highly complex responses.

Until the present time we have been too much inclined to accept at its face value the "bundle theory of the personality"—a conception based upon the somewhat crude assumption that in some mysterious way a series of reactions were merely grouped together, and, when these were brought into focus by some mechanism represented in the cerebral cortex, the idea of the personality was the final product. The failure to recognize the marvellous biological complexity of the synthesis expressed in the higher forms of activity has had unfortunate results. For example, it has been stated on purely theoretical grounds that one can have the simplest forms of perception, such as color sense, without the association of the ego. Some philosophers have taken this view; but practical experience tells us that the word *perception* predicates the existence of the ego. We are justified in this conclusion by our knowledge of the cerebral mechanisms at the basis of perception. We know that whenever the cerebral cortex is stimulated sufficiently to cause a conscious process, a considerable amount of reverberation follows. The ego and the perception are merely different phases of the same phenomena; and it is probable that one is so intimately related to the other that they never occur independently. The "bundle theory," as it is usually stated, cannot be reconciled with these known facts. The concept of the personality is one product of the process of living, and is a synthetic representation of experiences.

The part of the personality summarized in the "ego" is projected from a background of vague organic sensations, feelings, strivings, and perceptions—a constantly varying aggregate, although the subjective sense of fixity is the product of the emotional reactions. The "ego" has indeed a certain degree of constancy as it is experienced, but this

is quite unlike the constancy we meet in the inorganic world.\*

The personality expresses the individual's biologic capacity for adaptation, and in a certain sense measures the degree of adaptation of which he is capable at all the different levels of living—reflex, automatic, and voluntary. Psychologically considered, the personality is an immediate product of cognition, but cognition is in its turn the resultant of many biologic processes, among which are those collectively designated as recollection, representation, feelings, etc. These processes give continuity and stability to the organization, and thus the idea of permanence that is posited by the concept of the personality is an end product of these reactions.

The word personality is sometimes used in a restricted sense to characterize those adjustments of a human being that occur only in the higher planes of conscious adaptation. If the word personality is to be retained in our biologic vocabulary, it must be sufficiently elastic in its applicability to include the constant revisions in definition that the advancement of knowledge is sure to bring about. If we decide that the personality is merely a very convenient method of expressing collectively a complicated series of adjustments occurring at different levels out of which, Minerva-like, springs a combination of sensations, impulses, ideas, appetites, and habits that are recognized as the "self," and then if we are constantly on our guard lest emotion, not reason, should determine the limits of our definition, many difficulties long associated with the solution of the problems of personality will rapidly disappear.

Certain fundamental biological distinctions must be kept definitely in mind if we wish to make complete an examination of a personality. In the preceding pages we have seen that man's unity is much more complex and more centralized under the control of the nervous system than in the lower animals. We have also observed in certain organisms, like worms, remarkable instances of the regenera-

\* Schilder, P., *Selbstbewusstsein u. Persönlichkeitsbewusstsein* (Berlin, 1914).

tion of lost parts, an indication of the independence of parts or organs. The higher the scale of animal life, the more specialized do the various tissues become, and consequently the more intimately related and dependent upon central control do these various parts of the organism seem to be. For this reason the individuality of the higher species is a more complex synthesis of adaptations than that of the lower animals.

In our description of the cerebral cortex we have noted the fact that the higher in the animal scale we ascend the greater the tendency becomes to focus within this part of the brain many of the mechanisms necessary for adjustment in the upper levels of activity. In man the condition of centralization of control of the higher mental processes within the outer layer of the cerebrum is more pronounced than it is in the ape or dog; and the completion and preservation of the most complex synthesis of all is an important function of this part of the brain.

A person's individuality as a separate and distinct organism begins with the earliest stage of growth, when the brain centres are functionally inactive; whereas the sense of personality develops only when the highest cerebral activities of which human beings are capable become manifest. The individuality epitomizes many of the general traits that characterize us, while our personality is an expression of the higher and specialized forms of our activities; this latter phenomenon rests upon and intimately depends upon the former.

The distinction between "individuality" and "personality" is a convenient one for our present purposes. Individuality may exist in organisms without the presence of a brain and nervous system, whereas personality, in the sense in which the word is generally used, is to a large extent the functional expression of the higher brain centres. The individuality does not need a special mechanism of adjustment for the expression of its various relationships, but for the personality such a mechanism is a necessity.

The activities of individual existence may be far less

complex than those reflecting the personality. The problems connected with the individuality of the lower organisms and of man in the earliest stage of his life include the discussion of the fundamental properties of living matter; whereas the study of the personality carries us into a special field of research relating to the nature and development of adjustments depending upon the existence of a highly differentiated nervous system. The existence of a cerebrum, however, does not predicate the existence of specific functional traits.

We cannot lay too much stress upon the necessity for remembering that the conception of personality is founded upon that of individuality. An obvious truth, although one often ignored or forgotten, is that the various links in the mechanism of adjustment are very closely dependent upon each other. These reciprocal activities have been mentioned already in Chapter II in the references to the variety of reactions of which living organisms are capable. We saw then how many responses occur in plants, and in the simpler forms of animal life not possessing a nervous system, which appear to be dependent upon certain elementary forms of discriminative irritability or sensitivity. A second form of movement of a true reflex nature indicates the presence of a nervous system, or a specially differentiated mechanism of adjustment. In a third group may be placed the automatic movements often exceedingly complex but still unassociated with the conscious activities. Finally there are the volitional activities associated with consciousness. No one questions the fact that the latter forms of adjustment in the higher conscious levels are valuable elements in the mosaic of the personality; nor will any intelligent student of the latter attempt to dissociate them arbitrarily from the background of reflex and automatic actions with which they are indissolubly connected. And thus it is once again evident that, in analyzing the personality, the physical is inseparable from the psychical.

Although the various activities forming the basis of the personality have the tendency to blend or form syntheses,

it is well to remember that there is at the same time always a considerable fluctuation of the different levels—a phenomenon we find constantly illustrated in all the mechanisms of human adaptation. For example, movements that are generally automatic may be forced into the volitional level, while those requiring an effort of will may under certain circumstances become automatic. Thus to the novice the co-ordination necessary in riding a bicycle is attended by conscious effort not felt by the expert. Also, lines of activity in both thought and conduct ordinarily not arousing any sense of effort and carried on in health with precision and effectiveness may, when the body is weakened by disease or excessive strain, tax a person's volitional capacity to the utmost. On the other hand, even such complicated processes as speech may drop from the conscious to the automatic level. Thus there is a well-recognized symptom called *echolalia* occurring in certain forms of alienation, when the patient echoes sounds or words without any apparent conscious association. A phenomenon somewhat similar in character is observed also in people who talk in their sleep. Speech imitation does not necessarily predicate the existence of all the conscious activities generally associated with speech. Although a person may be aware of the speech activity, the degree of consciousness is generally of a most elementary form.

The constant shifting of levels so evident in regard to the lower planes of activity is equally apparent in connection with the higher processes. Many activities are continually going on below the level of consciousness, and only under exceptional circumstances are we aware of them. Impressions which at one moment seem relatively unimportant at another may serve to deflect and alter the entire trend of individual behavior. This continual shifting of the levels makes it sometimes difficult to appreciate the sense of continuity and permanence that is such an important factor in personality.

The personality is not something existing independently of the environment. We know that environment has been

a dominant factor in determining man's growth from the stage of savagery to the highest forms of civilization ever attained by him; and its immediate influence may often be studied in connection with the integration of the simpler reactions occurring at various peripheral points of the body, or in those sense-organs by means of which man maintains his contact with the outside world. Under certain circumstances these responses may assume so abrupt and intense a character as to become a dominating factor. An impression stamped on the sense-organs may play a rôle of great importance in a person's life by becoming the nucleus about which emotional reactions cluster. Some impressions may also be of such a vivid character as either to inhibit completely other activities or to bring about a somewhat spasmodic form of reactions. We know, for example, that intense light impinging upon the retina may temporarily divert the stream of attention from sound stimuli. Clinical experience furnishes abundant proof that the personality may suffer from a great variety of restrictions incident to abnormal sensory stimulation. We do not deny, however, that a relatively high degree of intelligence of a certain imitative type may be developed even when there is considerable interference with the sense-perception; but this kind of intelligence, representing a limited number of activities, forms only one factor in the entire synthesis of the personality. There may be decided dissociation of the personality, although the intellectual defects may be comparatively inconspicuous.

In estimating the effects upon the personality of the curtailment of sensory impressions (blindness, deafness) we are too apt to confine our inquiry to observing the results apparent in connection with the higher intellectual functions, and quite forget that primary disturbances are to be sought for in the anomalies of feeling. The blind are usually believed to be more resigned to their infirmity than are the deaf; a condition indicating the existence of specific changes in the emotional life. Since there is nothing in the intellect not first represented in the senses, it is obvious that

we need more elaborate and detailed studies relating to the indirect effect of sense-impressions in determining the character of the personality. There are many practical difficulties, however, that hinder the solution of this question. As every sense-impression is the nucleus about which emotional reactions gather, it is quite impossible to dissociate the various factors in a complex and to appraise their values accurately. Therefore we must be extremely cautious in making deductions from this study of the anomalous mental states; especially are these to be considered in relation to the more general biologic reactions of the individual. In patients who have suffered from some serious interference with the sensory mechanisms a tendency is often exhibited to form new mental syntheses, which seem to bring about a partial compensation for the lost functions; and hence there are also repressions of a compensatory nature which are quite as dominant as the positive activating forces.

There are also numerous collateral mechanisms, often ignored, that contribute a great many of the factors forming an important part of the basis of the entire personality complex; such, for example, are the labyrinthine and vestibular nerves that are parts of the auditory mechanisms. These structures are indispensable not only for the maintenance of the correct posture and movements of the head and the tonus of the neck muscles, but for their indirect contribution of significant quota to the sum total of the personality complex. The relative need for the preservation of the normal "static sense" is great, as may be readily inferred from observing people afflicted with disturbance of the sense of orientation.

In the development, or organization, of self-consciousness all sensations and memories are not of equal value, but under normal conditions optic stimuli and the "static sense" direct and shape the organization of many other responses essential for the creation and preservation of the sense of personal identity. A patient once came under the writer's observation who suffered from attacks of aural vertigo and accompanying sensations of "feeling as if two boards were

strapped to the sides of the head"; this disorder was associated with a distinct subjective loss of personality and a very disturbing depreciation in the sense of reality.

We shall not consider in detail here those other forms of reaction between the individual and the environment which we call instinct action and which are dependent upon the functional efficiency of certain (kleronomic) tracts in the nervous system as distinct from activities referred to other (embiontic) paths. The best way to study these instincts, is, as Wheeler\* has said, to experience them. Instinctive reactions often overwhelm consciousness without any warning, shooting suddenly into prominence in response to a need for readjustment. Instincts, particularly those concerned with the preservation of life, the continuance of the species, etc., have the same dominating tendencies that to a large degree characterize many sensory impressions.

The stability of these instincts varies. Those of hunger are more stereotyped in form than those in which there is a more complex form of organization, such as exists in the case of sexual and social instincts. The former do not carry with them any marks distinctively characteristic of the individual, while the latter are stamped with a very strong personal mark.

Out of a complex background, then, made up of sense-impressions, instincts, activities, indefinite organic sensations and emotional tones, emerges the consciousness of self. It is a curious fact that this singularly illusive and ill-defined group of activities has been usually discussed as if it were a specific and clearly defined phenomenon. On the contrary, self-consciousness, a synthesis of activities that forms such an important factor in the composition of personality, depends upon the focussing of many activities. The process, or rather processes, by which this takes place are most involved and develop very gradually out of a maze of reactions that form the basis of cognition. Cognition becomes equally valid for internal and external reali-

\* Wheeler, M. S., *Ants, Their Structure, Development and Behavior* (Columbia University Press, New York, 1910).



ties, and a man, from the knowledge of his own facts of consciousness, quickly learns to know himself; and this knowledge he gains by a series of contrasts between himself and objects or things.\*

For the purpose of bringing out the background from which the personality is projected, it is necessary to take into account not only a variety of definite sense-impressions and memories, but also the vague and shadowy complex of organic sensations (cœnesthesia). The membrane of the body, such as the meninges, pleura, peritoneum, and the coatings of the mouth, throat, stomach, and digestive tract, which are well supplied with sensory nerves, or such organs as the liver, spleen, pancrea, kidneys, etc., in health are not directly represented in the field of conscious activities, yet these organs exert a great influence in restricting the field or in limiting the rate of conscious adjustment in disease.† An inflammatory condition soon brings these areas under our immediate attention. The maximal and minimal realization of self-consciousness depends also very greatly upon the influence of subconscious activities, and upon the ill-defined complex of organic sensations,‡ which probably play an important part by entering, as organizing or disorganizing influences, into all the levels of activity, and must in a measure determine not only the sensory adjustments but also the actual character of memories, and often supply motives for voluntary action. The organic sensations are vague in comparison with the visual or auditory impressions, but it is possible that, although they do not arise sharply into the field of consciousness, they may dominate the great undercurrents that direct the stream of mental life.

As we should expect, the most balanced personality occurs in health, whereas in disease we meet with a more or less complete sejunction of the personality. We must there-

\* Varisco, B., *The Great Problem*, translated by R. C. Lodge (The Macmillan Co., New York, 1914).

† Von Niessl-Mayendorf, E., "Ueber die Physiol. Korrelate der Gefühle," *Ztschr. f. allgem. Physiol.*, 1912, XIV, Hft. 1.

‡ Titchner, E. B., *Lecture on the Elementary Psychology of Feeling and Attention*.

fore distinguish carefully between the harmonious, well-developed personality and the abnormal, exaggerated sense of self-consciousness so often an indication of defective adjustment. Disease is often of assistance in enabling the examiner to explore the phenomena of self-consciousness. For example, sometimes in states of exhilaration induced by drugs or during the stages of maniacal excitement a person has an exaggerated sense of self, associated with an increasing feeling of well-being and absence of fatigue. As a contrast with this condition we observe states of depression, in which the sense of well-being is restricted and the person experiences an increasing sense of effort and a tendency to underestimate the value of his self-complex. Those investigators who are inclined to adhere to the traditional notion of a permanent and immutable personality would find it impossible to reconcile these theories with the facts revealed by the study of individual cases. The concept, too, of one's own personality—a concept that gradually becomes a part of our being—is often disturbed when the vast complex of sensations and feelings composing it is shattered by disease. Slight changes in the functions of the brain or other organs cause failures in adaptation; finally ideas of self, time, and space begin to dissolve, and in the presence of such a crisis we may realize for the first time the marvellous complexity of the phenomenon of personality.

In exploring the relationships of the various conscious processes we find a condition that is not unlike the variability and polarity occurring in physical processes. The equilibrium seems to be maintained by a constant shifting of various elements. This condition is expressed in the phenomenon of attraction or repulsion, which is quite as characteristic of the volitional as of many physical phenomena. There is evidently a certain polarity of all the mental processes which enters very largely as a determining factor into the processes that have the appearance of being in opposition to each other. We have excellent practical illustrations of the apparent contrast, or opposition, in the different reactions of patients; for example, in the condition called

negativism, in which the person is thrown into active opposition by all that is proposed or attempted. This extreme contrariety is evident in feeling, thought, and act. The attempt to flex the arm causes extension of the limb; the effort to provoke mirth is followed by sadness; and the suggestion of one set of associations arouses a sense of repugnance and opposition. Often, too, the reactions of a patient serve to lay bare some of the underlying mechanisms by which the responses are conditioned. The same thing holds true in connection with many of the emotional reactions, particularly those of sexual origin.\*

In order to gain such a comprehensive and essential knowledge of the mental factors in any personality as will elucidate the nature of the mechanisms involved in its composition, it is also most important to have some idea of the synthetic unity expressed by conscious adaptation. To this end it is necessary to reiterate that consciousness is not merely a conglomerate of independent sensations, memories, feelings, and ideas, but is a synthetic organization. For the immediate consciousness the term *moment-consciousness* has been suggested.† So long as the balance between the various processes is preserved, harmony prevails and the organization is not interfered with. The inhibitory processes, which we shall mention later, have a significant bearing upon the regulation and control of the unity of consciousness; and are expressed in the synergic nature of the responses giving character to the personality.

A weighty element in the personality is the sensing of the successful synthesis, which is always vaguely but none the less actually represented in consciousness. In other words, a person "feels" the organization, and whenever the process is inhibited or repressed is often oppressed by a sense of inadequacy or insecurity. It is quite possible that, as the development of the individual proceeds, if the growth

\* Horstmann, W., "Zur Psychologie konträren Strebungen," *Ztschr. f. d. ges. Neurol.*, 1914, XXV, p. 175.

† Sidis, Boris, *The Foundation of Normal and Abnormal Psychology* (Richard Badger, Boston and Toronto, 1914).

of organs is retarded, or if they maintain certain of their infantile or foetal characteristics, these defects will be represented in consciousness and will carry with them a sense of restriction or insufficiency that may have decided bearing in extending the limits of disorganization.\*

When the sense of personality has been disturbed nature seems to make an effort to restore the balance like the regeneration of a lost part in the case of the lower animals. Some investigators find difficulty in realizing that the law of cause and effect applies in the same degree to the study of problems of the balance of the higher conscious activities as to reflex actions. But Yerkes† admonishes us that "we should not approach the task of studying the order of mental events with the idea that the only way to establish the existence of a causal relation between mental phenomena is to prove that the sequence of mental events are precisely like those of bodily events." Our chief duty, then, is to record the sequences as they occur, and if possible determine the factors upon which they depend. Causal relationships exist between phenomena that may possibly have the appearance of being incongruous reactions. We know, for instance, that pent-up feelings are often relieved by an outburst of sobbing or laughter, or by an explosive reaction in the motor field. Mental defects are compensated for by the development of collateral complex mechanisms. Thus, the person who is constitutionally inferior may try to conceal his infirmities behind a veil of cynicism, or by boasting of his imaginary powers. Indeed, our mental life in all its multifarious phases represents an extraordinary series of complex adjustments that change constantly to meet new conditions.

Philosophers, in discussing the synthesis of the personality, have often referred to the apparent contradiction between the seeming unity on the one side and the number of different factors on the other, represented in the complex.

\* Adler, A., *The Neurotic Constitution* (Moffat, Yard & Co., N. Y., 1917).

† Yerkes, R. M., *Introduction to Psychology* (Henry Holt & Co., New York, 1911).

The existence of a great variety of sensations, feelings, and representatives would at first thought seem irreconcilable with the idea of unification, but common sense tells us that such phenomena represent merely different phases or aspects of the final product, the personality. We might with equal reason deny the existence of unity to an organic chemical compound, because it is composed of many parts. In like manner the interrelationship of the various factors entering into the constitution of the personality may be said to form a distinct and definite unity.

In contrast to this unity of the personality, in those conditions of the so-called depersonalization, there are manifested some of the essential mechanisms upon which the personality is built up; but this will be made more explicit in the chapter on Dissociation.

Some investigators draw a distinction between the changes occurring in self-consciousness and the consciousness of the personality. One patient may recognize the extent of the depersonalization and feel that he is "completely transformed into another being"; while others are no longer human beings, as they have "no souls." In other instances there is a distinct doubling of the personality, and the attention is directed more and more toward introspection. Occasionally not only a double but a multi-form personality seems to exist; and all are transient and may readily disappear to make way for some new manifestations.

The recall of a chain of impressions, essential for the preservation of a sense of harmony and identity, represents a recapitulation of succeeding bodily states which has been described by Ernest Jones as the somatognostic sense. The synthesis of ideas forming the basis of personal identity may be disturbed (1) by interference with the reception of sensory stimuli, (2) by disorders in the working up and elaboration of the same sensory impressions in the brain, and (3) by anomalies occurring in the mechanisms of reproduction or the recall of engrams (disturbances of the autosomatognostic sense).

We may cite one example of curious and disconcerting disturbances that reduce the sense of proprietorship over one's own body. Such a one, particularly interesting, was the case of a man who suffered from paralysis of the left leg and arm. During his acute illness he showed no recognition of the paralyzed extremities. Later, upon recovery from the severer symptoms, it was learned that the patient had suffered from loss of motion and had forgotten all the somatic memories associated with the left side of the body. He felt only "half-sided," and could form no notion of the sensation experienced by a person when both sides of the body are intact. *Autotopnosia* has been suggested as a term descriptive of a person's incapacity to orient correctly different parts of the body, while *achiria* has been reserved to designate those cases in which in addition to the defective orientation, there is a loss of feeling in such parts. From a careful analysis of such cases it is evident that not only is there a marked defect in the sense-perception but in the various disorders in processes contributing to ideas relating to the two sides of the body.

The more we study the personality the more we are impressed by the continuous activity and sequence in the multiform adjustments; in other words, we are dealing not with a state but with a process. Naturally, during hours of sleep these activities are limited to reflex and automatic levels, except in the case of dreams, which deserve special consideration. In one phase or another activity is nevertheless continuous. All the forms of adjustment, either directly or indirectly, affect the personality, and the forces shaping this may be said to be grouped under those that tend to produce a synthesis or its antithetical state—a sejunction. It has been stated that every personality is at the mercy of the brute instinct which, in an instant, if given full sway, may transform the old personality into a new one.

The mechanisms determining the various transformations show an endless variation, and require careful study, since they are involved in both normal and abnormal reactions. Many different views have been expressed as to

the mental processes immediately concerned in the development of self-consciousness and the associated sense of reality intimately bound up with the whole subject of the personality. Here again the study of pathologic states has been of great service in analyzing this complex synthesis.

There are also many different opinions as to the factors responsible for the consciousness of our existence. Some hold that it is not communicated by perceptions, memories, thought-processes, or volitional acts, but is the product of one or more special psychic functions which are the chief determinants in the development of the ego. In support of this theory the following reasons are cited. Experience teaches us that, under normal conditions, sense-perceptions are accompanied by a general consciousness of existence. Reproduced memories of dreams and certain pathologic states are connected with the same sense of reality that attends the development of sense-perceptions due to external stimuli. That which we have perceived through the ordinary media of sense-perceptions receives the stamp of reality. As contrasted with these normal conditions, patients with hallucinations reproduce perceptions, see visions, or hear sounds without questioning the reality of the phenomena. Occasionally persons may possess the normal capacity of sense-perception, may be capable of logical thought, and not be subject to defects of memory. Yet in spite of this retained capacity for recollection, they may be strangely defective in that part of consciousness which relates to the external world. One person declares "my own bodily sensations are quite normal, but the world outside of me is strange and unreal." Another, while fully realizing that he stands, feels, and thinks, may nevertheless be doubtful of his own existence, or, as yet another may express it, "I am at work doing one thing, then another, but I can't convince myself of the reality of it all."

Such examples of depersonalization make clear that our research has established the fact that the mechanism of sense-perception produces the consciousness of existence which is communicated by either the senses or by repro-

duced memories, as in dreams or hallucinations that have the character of sense-perceptions. This important element in our personality does not seem to fluctuate with the changes of memory or judgment, but exists more or less independently of them. Some observers find no evidence in favor of the view that the actual consciousness of reality or existence is in any way directly dependent upon the function of the muscular system, inasmuch as patients with marked degree of depersonalization may present no symptoms of cœnesthetic disturbances. Since the examination in such cases is usually limited to testing the functions of the skeletal muscles and has as its chief object the discovery of changes in the peripheral organs, the absence of positive evidence is in no wise conclusive. It is also quite probable that present opinions as to the composition of the senses of reality and familiarity, which under normal conditions are the foundations of the feelings of gratification and satisfaction in living, will need revision in order to meet new data as they may be presented.

These studies of abnormal conditions have already thrown considerable light upon the structure and relationship of many of the components of the personality. Clinicians have called our attention to the fact that, when there is a marked degree of depersonalization, the patients seem to be incapable of vividly sensing their ideas, particularly those related to the visual and auditory impressions, although there is no absolute extensive demonstrable loss of perceptual capacity. So far as can be ascertained, in such cases the cognitive processes are not strongly affected, even though the mechanisms of recall appear to be impaired. Also the attention cannot, as a rule, be easily concentrated during the attacks, while the thought processes are sensed as automatic and there is complaint of loss of power to direct the mental activities. It is, however, still an open question as to what extent the dynamic power of the will is reduced.

The fact that consciousness is a process, not a state, has an important bearing upon all cognitive acts. But this is in no wise incompatible with the belief in the relative



permanence of the personality, with its predicate of individual identity. Many persons have hesitated to replace the theoretical conception of an absolute personality with the one that conforms with the facts and is relative in character. There is, however, no ground for the supposition that such substitution is subversive of the basis upon which our conception of law and knowledge rests. As Tarde\* has said, the idea of a relative permanence of the personality is not at variance with our idea of responsibility. The psychological individual or self is, as we have explained, a mosaic of sensations, bodily feelings, impulses, tastes, and all activities expressed in the life of a man. We find in this assemblage a sum of memories, or engrams, habit reactions, and representations of the various forms of sense-perceptions that characterize each person. We have also indicated two processes as continually at work, the one tending to harmonize and continue the processes begun, and the other to inhibit them. If, according to Paulham,† we reflect upon the evolution of the individuality in the psychological synthesis that we call personality, there are many interrupted processes represented as well as those that are initiated and completed. In any one person this predicates a continual change of ideas, tendencies, and tastes, hour by hour and day by day, and, so far as regards the development of the synthesis, inhibition is important in these adaptive processes. Of this we have constant proof in our changes of mental attitude and thought, in the discarding of old and the formation of new ideas; and each new association formed necessitates a breaking off and interruption, or rupture, with the old one.

And, finally, the principle of reality is more in evidence as the development of the personality becomes more complex. A relatively high degree of reality is attainable only in persons of considerable intellectual ability. The development of the race shows as clearly as does the individual man the

\* Tarde, A., *Penal Philosophy*, trans. by Rapelje Howell (Little, Brown & Co., Boston, Modern Criminal Science Ser.).

† Paulham, F., *L'activité mentale* (Librarie, Félix Alcan, Paris, 1913).

association of the reality with ratiocination. This principle of reality neither exists in the primitive stages of society nor in the early periods of life, except in so far as mere indications of it may be traced. Gradually, in response to the inhibition of instincts and of pleasurable desires, the emotional reactions that were originally repressed, precipitated conflicts, and man thus became conscious of *unrealized* yearnings. From this it follows that the "highest standard of human adjustment is brought about through the principle of reality"; and this achievement marks the completeness of the synthesis expressed in the personality.

## CHAPTER V

### THE DEVELOPMENT OF THE PERSONALITY

FOR many centuries man's naïveté in discussing personal problems from the outlook most gratifying to his own pride led to the creation of an imaginary world, inhabited only by people at the prime of their activities, possessing an unusual degree of emotional stability and considerable intellectual development; and as a result of this restricted point of view an exceedingly limited period in the entire span of life became the centre of interest. Philosophers attempted to explain human conduct as part of a scheme which did not take into account the activities of individuals rendered defective either by disease or imperfect development, and failed to link the growing activities of infant and child with those of the adult. Systems of law, ethics, religion, and education were deliberately planned with reference only to the needs of the relatively few persons who were capable of attaining a high degree of intellectual activity and volitional control.

So entirely absorbed did man become in contemplating the success achieved by a comparatively few persons at the acme of their physical and mental powers that he had no intelligent interest in the many chapters of his life history. It was only later that the recognition of the fact that there are no specific differences between the activities of the sane and insane was supplemented by the revelation of the unbroken continuity of the chain which links together epochs not only in the growth of the individual but also in that of the race.

The delay in the development of genetic psychology is an interesting comment upon the failure of human intelligence to appreciate the importance of the study of the simpler infantile reactions of the nervous system as a necessary

preparation for understanding the complex phenomena of the adult personality. Rousseau's declaration, "We do not understand the children," called attention to the general

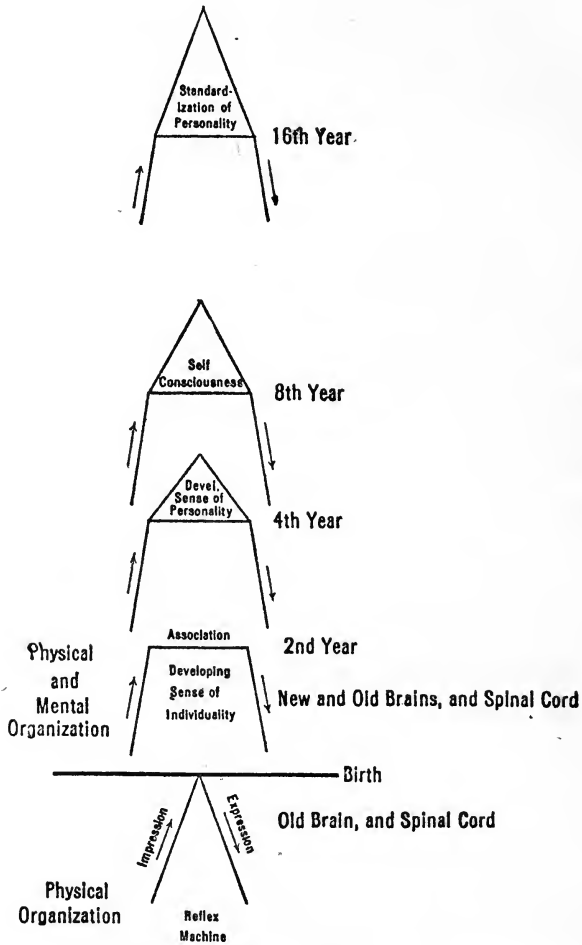

EPOCHS IN THE DEVELOPMENT OF THE PERSONALITY

deficiency in our knowledge of this field of research, but unfortunately for nearly a century his voice was that of the prophet crying in the wilderness. Even as recently as the year 1906 a distinguished scientist (but, needless to say, not a specialist in the science of human behavior), in expound-

ing theories of conduct, declared that even before birth the baby is capable of thinking and feeling—a belief recalling the one expressed by Malabranche when describing the embryo in utero as capable of experiencing similar feelings and reacting to impressions the equivalent of those influencing the behavior of the mother. Quite in line with this hypothesis was the former notion to the effect that if the mother was a musician and during her pregnancy played the piano the child subsequent to birth would be found to possess musical talent.

Many of the questions of mental development may be studied to the greatest advantage when considered in relation to the general growth of the person. "The body," as Ward\* says, "becomes the earliest form of self, the first datum for our later conceptions of permanence and individuality." Every human being is an indivisible biologic unit in which physiologic processes are so intimately connected with the physical structure that it is useless to attempt to consider the development of structure and function independently of each other. Man is not divisible into a body-and-a-soul individual. His personality, as we have seen, may be regarded as the measure of the biologic capacity of the organism to form syntheses and therefore its genesis cannot be studied as if it were made up of separate sections. We are not, however, in any sense trying to account for function by structure, but merely to trace the correlations existing between them.

Since the fundamental activities of all living organisms are expressed either in the phenomena connected with self-preservation or self-development, some familiarity with the reactions directed toward this end as they occur during the early periods in the growth of the organism is essential to understand what takes place later when the personality begins to take shape. The recognition of this principle is also the equivalent of the admission that a psychological analysis of the personality alone can furnish little evidence of

\* Ward, James, *Psychological Principles*, p. 165 (Cambridge Psy. Library, 1919).

the factors which give direction to the stream of activities or determine the rate and strength of the currents imparting the characteristic stamp to temperament and mentality.

The organism at the beginning of extra-uterine life has the capacity to react with a few innate and unconditioned responses; it adjusts itself by these mechanisms to meet the changes in the environment. But gradually from these are built up a great number of conditioned reflexes to satisfy the new and increasing demands. Therefore it is evident that the growth of the infant into the adult includes not only an expanding and deepening sensitivity or awareness of the environment, but also an increasing ability to react in complex ways to this environment, by the co-ordination, correlation, and association of processes.\*

For the acquirement of a comprehensive idea of what takes place during the genesis of a personality as a preparation for tracing the steps of the process by which the range of adaptation is extended to the inclusion of the higher conscious reactions, a beginning should be made by analyzing the primitive responses over which it is evident the nervous system has begun to assume control. If we ignore these simpler responses and relatively uncomplicated integrations, we shall miss an opportunity of forming some idea of the ground-plan of the finished structure represented in the adult personality.

X We have already noted that in the growing organism the process of adjustment is at first practically limited to the establishment and maintenance of the physiologic equilibrium—chiefly the regulation of the chemical balance; and that under normal conditions a physiologic balance or adjustment is established and maintained. We have seen, too, that in the earlier stages of growth, incident external stimuli appear to have little effect in bringing about new adjustments, and that generally the first movements noted are those of the heart, and that both these and the primitive

\* Pawlow, I. P., "Arch. d. Sc. Biol. St. Petersburg, 1905," p. 11, *Brit. Med. J.*, 1913, II, p. 973. Myerson, A., "The Conditional Reflex of Pawlow," *Interstate Med. J.*, 1915, XXIII, p. 515.

movements of the body are not modified so directly by changes in the environment as are the later adaptations occurring in the higher planes. Also we have emphasized the fact that these primitive movements of the body are the results of impulses that are generated within the nerve cells, to a certain degree independent of changes in the environment; and that these seem to be discharged at more or less regular intervals with the consequent production of the rhythmic effect associated with the early form of adjustment. During this period the organism is naturally less adaptive to diversified environmental conditions than at any other period of its life.

All forms of adjustment, whether reflex or conscious, unceasingly react to environment throughout the life of the organism. The reflexes have often been described as if their forms were invariably fixed and absolute, but this is only true in a very limited sense; and it is most desirable to recognize that even these primitive, apparently stereotyped forms of reaction have a certain plasticity, and in a biologic sense are as directly susceptible of modification as are any of the other responses.

It is important, moreover, that we should have some idea of the manner in which the higher functions are elaborated from these more or less stereotyped reactions. If we fail to notice that the integration of mechanisms carrying us from one level to those above is accomplished without a break in the continuity of the chain, or if we assume that the change cannot be explained without the introduction of some specific element, then we shall have introduced a principle which will have made it almost impossible to consider the mental and physical phenomena in any relationship that does not bring them into sharp contrast. Out of the primary, so-called unconditioned reflexes others are built up which are heavily conditioned, and as Myerson (*opus cit.*) points out in his excellent critical review of Pawlow's work, whenever a new incident stimulus impinges on the organism, striking a spot which has already been thrown into excitement, a process of focussing ensues so that the

modifying conditions originally imposed upon the reflex are extended until a conditioned reflex in the sense described by Pawlow is the resultant. The introduction of another mechanism, namely an analyzer, is also necessary to bring the organism into more extensive contact with the environment, or, as it may be called, a selector which chooses the form and intensity of stimuli that may be picked up with advantage to the organism. The selecting apparatus is composed of the receptors, sense-organs, and the attached nerve cells and fibres. The selecting capacity is rapidly extended during the ordinary period of growth, and an equilibrium is established between the power to receive and reject stimuli. Under normal conditions the power of discrimination is finely adjusted and the picking up or dropping of impressions safeguards the process of growth. In studying these primitive types of reactions it is undesirable to focus attention too exclusively upon a single phase of the response, as the physiologist is inclined to do whenever he attempts to explain the manner in which the less conditioned reflex is developed into the more complex types. We should also devote more attention to the consideration of the stimulus and its relation to the subsequent reaction. It is just on this account that the conception formulated by Semon to which reference was made in Chapter II is particularly suggestive in helping to bring out the unity of all parts of the process concerned in any reaction, *i. e.*, stimulus, reaction, and environment.

Having reviewed some of these elementary factors common to all forms of adaptation, we are better prepared for the consideration of the special problems connected with the genesis of a personality. The mechanisms concerned in the development of the infant are, first, an increasing awareness of the environment, followed by an increasing ability to react in complex ways to the environment. The contrast at the time of birth between the immaturity and helplessness of human beings in regard to the environment and the comparative independence of lower animals is well known. Development of the adjusting mechanism, par-



ticularly of the nerve centres above the lower levels of the medulla oblongata, but not yet including the cortex, has proceeded much more rapidly during intra-uterine life in the case of the lower animals than in man. The chick as it emerges from the shell is much in advance of the new-born babe. The ability of the former to maintain its upright position, and the possession of well-developed visual and auditory centres are in marked contrast to the deficiencies of the latter.

As development progresses it is obvious that responses must take place more directly in reply to a greater variety of environmental stimuli. These conditions are associated with the formation of many new organic chemical compounds which affect the general equilibrium—conditions generally described by saying that the organism has become more responsive to stimulation. These biochemic conditions, even early in life, have a decided influence in shaping the personality. Modifications of the chemical constituents of the body may deeply affect the development of the central nervous system, and thus changes in the synthesis of activities as expressed in the personality may be brought about. It is known, for example, that a lipid-free ration not only diminishes the growth of the body, but results in a considerable reduction in the weight of the nervous system and alterations in different parts of the brain. In human beings variations in metabolism of this character would affect the personality by inducing changes in the brain and nervous system.\* The extraordinary indirect influence of various organs in determining the synthesis of the higher activities will be considered later. Although on account of the gaps in our knowledge the facts connected with the physiology of various organs seem to be without direct bearing upon the complicated problems of the personality, it is nevertheless advisable to approach the task of preparing an analysis from a standpoint which does not ignore the possibility that new and unsuspected correlations between structure and

\* Hatai, S., "The Growth of Body and Organs in Albino Rats Fed with a Lipid-Free Ration," *Anat. Rec.*, 1915, IX, p. 1.

function may be established by additional evidence. The recognition of this possibility reduces the danger of considering the personality as a series of phenomena that are unrelated to the general activities of the growing organism.

The changes in the general ensemble of reactions recorded in the episodes of life in childhood, youth, manhood, and old age represent a series of adaptations modified by the functional activity of various internal organs, such as the heart, lungs, endocrine glands, etc., and some of the phases of these responses can only be stated in physiologic terms. In order, however, to understand the ensemble, we must have, in addition to the special knowledge of the parts, a comprehensive idea of the synthetized activities or general behavior.

Since the cerebral hemispheres are the parts of the apparatus where the activities are focussed for expression in behavior, we should be especially interested in these portions of the brain. Even some of the early gross morphologic characteristics may be in a general way correlated with certain aspects of the personality. We know, for example, that the weight of the male infant brain at birth is about 752 g.; while that of the female is about 30 g. less than this. From the tenth to the fourteenth year the former has increased to about 1,346 g., and the latter to 1,221 g. At the prime of life the weight of the average male brain varies between 1,380-1,400 g., and the woman's is from 25 to 30 g. lighter.

The general morphology of the brain demonstrates that there are a number of different factors which have an important bearing on the development of function and the genesis of the personality. H. H. Donaldson says that the brain has practically attained its maximum weight by the eighth year, and, with a few exceptions, only a slight increase follows until the thirteenth and fifteenth years are reached. During old age, as the result of atrophy, a considerable diminution occurs. In spite of the proportionally larger size of the brain at birth as compared with the body weight, the functions of the organ at this time are singularly

immature. During the first four years of life the different parts of the brain do not all develop at the same rate.\*

Not only in the gross anatomy but in the arrangement of the microscopic elements we find interesting data for tracing some of the factors connected with the genesis of the personality. The entire process of the development of the neural elements in the brain may be divided into four separate stages. First comes the period at which the cells, having divided and multiplied, are succeeded by a migration from their place of origin to their ultimate destination; then follows a definite rearrangement of the elements in a manner characteristic of the adult tissues; and finally the actual differentiation of nerve cells and nerves takes place. To what extent this latter process is continued after birth is still unknown. The process of cell division and multiplication is supposed to be practically completed at birth, so that there is probably no further increase in the number of elements present. But it may be possible that cells which have not actually developed the characteristics of nerve cells at birth, and remained indifferent, may later when subjected to appropriate stimuli become nerve cells.

The question of the subsequent transformations and development in response to stimuli of the so-called indifferent elements and the possibility of their becoming nerve cells is of great practical importance. A migration of undifferentiated cells not having attained the characteristics of nerve cells takes place from the inner walls of the hemisphere outward toward the cortex. Years ago the writer was impressed by the striking appearance of these cells, strung along in columnar arrangement and so placed that they gave the appearance of streaming upward from lower levels into the cortex. At the time this observation was made no explanation of this phenomenon had been attempted, but Mellus later traced the origin of these neural elements to regions bordering the inner walls of the hemispheres. There are many interesting hypotheses that might be

\* "The Growth of the Entire Brain and Its Chief Constituent Parts during First Four Years, after Pfister." See Canestrini, p. 5.

brought forward to explain the possible effects of properly directed stimuli (education) in determining the development of the nerve cells. Would it be possible by the use of the right kind of stimuli to compel cells which might have remained in an indifferent state to assume the properties of nerve cells? But if we are in doubt as to the possibility of actual increase in the number of nerve cells after birth, it is known that the actual volume of the neuroblasts, the embryonic nerve cells, swells very perceptibly from birth until the prime of life. At fifteen years of age the volume of the cell bodies of a few of the largest elements may be 120 times, and at thirty as great as 150 times, that of those in the cortex of the new-born infant.

The cerebral cortex, the portion of the brain most closely associated with the higher brain functions and regulating the synthesis of the personality, reveals a marked contrast at birth with that of the adult. At birth none of the nerves that convey impulses to and from the higher brain centres have received their medullary coatings, and many of them are incapable of functional activity. The incidence of functional activity does not coincide so closely as was once believed with the development of the medullary sheath; and so medullation cannot be used as a very exact index of the correlation between structure and function in the nervous system, although it has been of considerable value as an index to the incidence of functional activity.

The first of the brain centres to develop in the infant are, from a phylogenetic standpoint, the oldest and are connected with the palæencephalon, and consequently have been described as palæopsychic. The reactions from these centres are limited to the reflex and automatic levels. These nerve paths ready at birth to transmit impulses have been designated kleronomic (hereditary) to distinguish them from the embiontic tracts, which develop during the life of the individual and are largely represented in the cortical areas.

The reflex and instinctive mechanisms, as we have noted, are largely, if not wholly, dependent upon the kleronomic

tracts, whereas the more complicated forms of associated memory and the higher intellectual functions depend upon the development of the embiontic paths.\* The primitive adjustments in which the muscular system is to take an active part, furnishing the basis for all voluntary reactions, begin during intra-uterine life. These early responses are dependent upon the kleronomic mechanisms. The mere act of repetition of the muscular adaptations indicates the existence of one form of organic memory. When we pass from the consideration of the correlation of the structural conditions in the brain with these simpler responses to the study of the least complicated of the phenomena usually designated mental, it is surprising to find that interest in these and the part they were supposed to play in the psychogenesis of the personality was aroused as early as the eighteenth century, when Tiedmann published one of the first recorded contributions relating to the mental development of children.† In 1859 the celebrated physician Kussmaul, in his *Untersuchungen ueber Seelenleben des neugeborenen Menschens*, made a series of observations on the soul-life of the new-born infant, a book that was followed in 1882 by the appearance of Preyer's classic work, *Die Seele des Kindes*. From these beginnings we may date the inception of modern methods of studying the genesis of the mental faculties.

During the last half-century there has been an interesting series of efforts to correlate the known structural conditions of the brain with the development of psychologic functions. As long ago as 1872 Broadbent‡ described in the adult "centres of perception" and "of conception" in the cerebral cortex, and in a general way indicated the mechanisms which were supposed to be concerned in the process of a fusion of primary percepts. It was then believed that in the evolution of an idea primary percepts were not directly fused by the functional activity of contiguous nerve

\* Ziegler, *Der Begriff des Instinktes einst u. jetzt* (Fischer, Jena, 1910).

† *Beobachtungen ueber die Entwicklung der Seelenfaehigkeiten bei Kindern*, 1787.

‡ "On the Cerebral Mechanism of Speech and Thought," trans. *Roy. Med. Chir. Soc.*, 1872.

tracts but only by means of interposed cortical stations not in direct anatomical connection with the lower brain centre. A number of years later Flechsig adopted and modified this hypothesis and attempted to elaborate and substantiate some of the ideas expressed by Broadbent, showing the order and relation in which these centres developed after birth. He described in detail the chronological order in which the nerves to the various centres received their medullary sheaths, and blocked out on the surface of the brain a large number of areas which were supposed to have certain specific functional qualities. Although these views aroused great interest and unquestionably led to valuable investigations, the strict localization in the Flechsig sense, for reasons already suggested, cannot be maintained. The higher intellectual processes represent exceedingly complicated adjustments which express activities of the cerebral cortex, of the lower centres of the brain and spinal cord, and of the sympathetic and peripheral nervous systems. The development of the cerebral cortex is accompanied by an increase in the individual's capacity to react to situations which rapidly become more and more complex.

All such studies point out the interest appertaining to research into the correlation of the structural changes taking place in the central nervous system subsequent to birth with the functional expansion. It is now in order to describe some of the chief steps in the genesis of the personality and to indicate how some of the integrated responses are elaborated from comparatively simple reactions. First let us note some of the chief epochs in the genesis of the personality. These may be represented diagrammatically, as originally suggested by Spitzner in a diagram which however differs materially from the one here developed.\* We may begin with the time when the nervous system enters as an important factor in the mechanism of adjustment. Prior to birth there occur the rhythmic movements of the heart and body. These at first are not modified in

\* Spitzner, A., *Das Kind, seine körperliche u. geistige Pflege v. Geburt bis z. Reife*, II, p. 72 (Enke, Stuttgart, 1911).

their action by the ordinary stimuli. This state is represented by *A*. Here the efferent or driving impulse is the only one conducted.

Next there is the pure reflex as indicated in the stage *B* with an ingoing or afferent impulse passing from the periphery of the body (*p*) into the nervous centre (*c*). In the

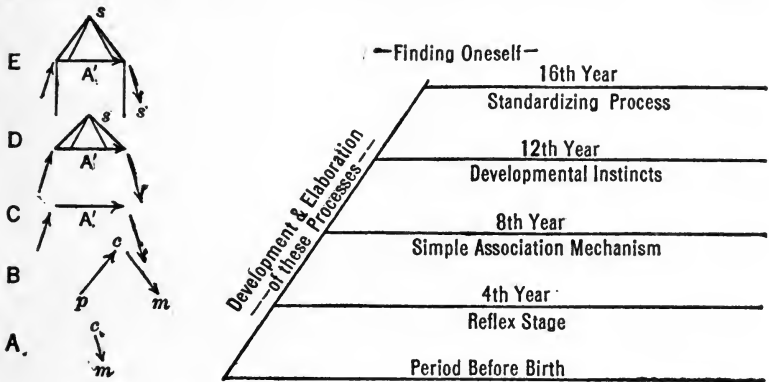

*s* equals self-consciousness. *A'* equals association mechanism. *c* equals nerve centre. *m* equals muscle. *p* equals periphery.

next state the working up and elaboration of impulses begins to become a more prominent factor, as is indicated by the interposition of a connecting and elaborating path between the ingoing and outgoing stimuli. Soon (*D*) the outlines of the adult personality begin to assume definite characteristics and these, becoming more pronounced, finally culminate in a definite form (*E*) of self-consciousness that marks the period when the individual "finds himself."

The final synthesis of which one characteristic is self-consciousness may be traced back to very simple beginnings, since we have seen that the forms of response first attracting attention in the embryo are those depending upon muscular contractions independent of neural control. At birth a human being is practically brainless, all the higher functions associated with the cerebral cortical centres being still undeveloped. The excision of these higher centres at birth in some of the lower animals has probably no effect in disturbing the motor responses of the young animals, and sim-

ilar conditions are believed to hold true for man. The primitive motor responses of the human embryo may be classified as follows: (1) Simple impulses resembling discharges from an electric battery and taking place at a time antecedent to the differentiation of definite nerve tracts; (2) the typical reflexes; (3) subsequent to birth the instinctive adjustments; and finally, (4) those impulses in which there is participation of the central adjustor or higher brain centres.

Although many of the movements of the new-born infant are apparently purposeless, all occur in response to some expressed need of the organism. The degree of co-ordination characterizing them is not in any sense a proper measure of their purposefulness. The mechanisms of co-ordination are exceedingly complex, and should be analyzed in relation to the functional development of the nerve tracts carrying incoming sensory impulses (extero-ceptors) from all parts of the body, including both the skin and muscular system (proprio-ceptors), besides those from the joints, bones, and internal viscera (intero-ceptors). The increasing capacity of the body to develop co-ordinated activities of groups of muscles indicates the existence of a very elaborate apparatus for effecting muscular contractions, which in order to serve a definite purpose are thoroughly timed and balanced, as well as marked off with appropriate strength.\* By the analysis of the various steps in the development of the mechanisms of co-ordination we may finally succeed in tracing the process of integration up from simple reflex discharges to the sentient and elaborate movements associated with volitional responses. The relation of these early movements to the development of a sense of external reality is an interesting field for exploration, and is undoubtedly connected with the first sensing of effort in overcoming resistance; eventually developing into the idea of occupying space. Autantitypy is the term suggested by Hamilton† to describe this special form of adjustment.

\* Maloney, W. J. M. A., "Co-ordination of Movement," *J. Nerv. & Ment. Diseases*, 1914, XLI, no. 5.

† Ward, James, *Psychological Principles*, 1919, p. 163.



One value of a careful examination of the early motor activities would probably lie in the intimation it would convey to us of the character of the higher cortical functions. We rarely consider the close association of movements with the development of the emotional life; that muscular movement is a form of emotional response.

We have already had occasion to refer to the intimate relation of the motor responses to the mental life of a person, but these facts are sufficiently germane to our immediate topic to warrant repetition. Emotional responses are expressed in various ways, and muscular activity is one of the most essential in the entire complex. A large part of the reaction in states of hope, fear, or pleasure is muscular, while the spread of the response so that more movements are involved depends largely on the functional activity of the muscular system and the nervous mechanism by which this is controlled and regulated. In the adult brain there are countless direct and indirect lines of communication between the sensori-motor and psychic areas of the cerebral cortex, and these are also in very close connection with the great sympathetic nervous system which plays such an important rôle in connection with the functions of the various glands. It would be a valuable contribution to secure a careful correlation of the facts bearing on the increasing complexity of function of the glands of internal secretion which regulate the emotional control and the development of the communicating paths in the central nervous system. We should understand more about the effect of the development of the brain centres upon the activity of such organs as the thyroid and adrenals, since it is known that in the adult the disordered functional activity in these higher levels may spread to the lower centres in the base of the brain and medulla, lead to various disturbances of the cardio-vascular apparatus,\* and cause disorders of the emotional life.

As we watch an infant lying in its cradle we are struck

\* Pighini, *Riv. speriment di Freniat*, 1917, XLII, p. 298; Orr and Rows, *Brain*, 1918, XLI, p. 19.

with the gradual associations formed between postural changes, the increased facility in performance of movements predicating the dawn of motor images, and the growing capacity to co-ordinate. The extreme delicacy in the co-ordination and association of these mechanisms involving an integration of activities that represent peripheral, spinal, and cerebellar elements, is rarely brought to our notice. Attention has been directed to the fact that, although the initiation and inhibition as well as the control of the gross rate and force of a movement may fall within consciousness, as a rule, the force, rhythm, rate, and synergetic quality of the contractions are automatically adjusted. These transition stages, marking the beginning of voluntary control, may be studied to great advantage in the child as it passes from the period of early infancy to childhood.

Dearborn has given a recapitulation of the chief events in the life history of an infant from birth to the end of the 152d week. In it he shows that the reactions developed during this period form the foundations of the subsequent relations to self, herd, and problems of sex.

Even after consulting such a recapitulation and with the different objective events brought to our attention it is still difficult for us to apprehend the full significance of movement and to associate it with the adaptations represented by the conscious processes. The connection in all cases is hardly an obvious one; the extraordinary unity and harmony of the integrated responses so baffle analysis. One example will illustrate this point, namely, the universality of the muscular tonus.\* This is a condition which is responsible for the preparedness of the muscle for action—not only for that activity displayed in all forms of behavior, but in the maintenance of the body's equilibrium, the establishment and preservation of the various postures, the stereognostic sense, autantitypy, the sensing of the occupation of space, the ability to judge weights and measure, the appreciation of jarring or trembling movements, and the regulation of the inhibitory processes. Additional evidence

\* Dearborn, G. V., *Movement, Anesthesia and Mind*.

as to the importance of the muscular apparatus, supposed to form about one-half of the body's mass, is obtained from observing the particular sensations associated with movement (kinæsthesia) and from exploring the enormous group of common sensations (cœnesthesia) which are the contributions of the human machinery in motion to the complex popularly described as mind and soul. A very useful suggestion has been made\* that we reserve the term "kinesthetic sensation" for the directing constituents in the sensations associated with movement, and call these elements auxilio-motor, unless we prefer the excellent term "dirigo-motor," which has the advantage of having been employed by Herbert Spencer to designate the kinetic factors. Kinetic is used here, as Ward has pointed out, in the same sense in which it is employed by the physicist to include momentum and pressure. The conception of force would be of little practical value to us, unless it was coupled with other factors conveying an idea of spatial perception.

The data furnished by the nervous system about the various processes active in the body may be very unobtrusively introduced into consciousness during the genesis of mind, but when once present strange gaps, perhaps both disconcerting and terrifying, are observed when by reason of disease any of the details necessary to action of different organs are lacking.

Impressions emanating from the different organs, although confined to the border line of consciousness, or often lying below it, are important parts of the foundations of all mental processes, and are as essential to the normal, well-balanced mind as the constructed cellar is to the substantial and well-planned house. To interfere with these impressions or memories would be as serious a mistake as to tamper with the foundations of a building.

The extreme complexity of the machinery existing, even at a very early period, for the collection and elaboration of the information afforded by the viscera, is perceived by familiarity with the nervous apparatus formed long before

\* Ward, J., *opus cit.*, p. 136.

birth for controlling the various organs. The large bundle of the great vagus nerve and the auditory nerve stand out sharply in microscopic preparations, and reveal the marvellous provision made in the embryo chick for supplying the heart, lungs, intestines, and auditory apparatus—those portions connected with hearing as well as the parts regulating the stability of the body at this early stage. Pathways for conveying the countless elements of the great stores of common sensations have already been provided at this time. We have only to look at this network of lines for the transmission of sensations and impulses from the intestines to see the reasons for the popular assumption of an intimate connection between processes going on within the brain and those taking place below the diaphragm.

It would be extremely valuable to know the order in which the integrations essential for the proper co-ordination of sensory impulses coming from the muscles, skin, joints, and bones are built up. All these contributions from different structures not only play an important rôle in regulating the rate, rhythm, and synergic quality of the muscular responses, but have a very direct bearing upon the formation of a proper basis for the future mental life of the individual. If the perception of either posture or movement is in any way defective in the infant, a serious obstacle is present which may interfere, to an extent seldom realized, with the evolution of the high faculties.

It might be possible to form some idea of these integrations from the study of the infant's movements, particularly those connected with the first movements described as voluntary. When the nerve tracts in the spinal cord are not all developed sufficiently to insure complete working order, it is far easier to comprehend some of the steps by which visual, motor, and emotional elements are all combined to give a definite sense of posture or movement directed toward attaining some particular object. It is not unreasonable to suppose that if we were thoroughly familiar with the links in the chain of integrations resulting in the simpler perceptions of position and stability we could then trace

just what happens when an act of suppression or inhibition occurs. Until we have this elementary knowledge (which must be derived largely from the study of reactions taking place during the earlier weeks of life) it is useless to speculate as to what happens in the inhibitions of perceptions. We shall not be in a position to discuss the problem of inhibitions intelligently until we are better informed as to the relations between such relatively simple integrations as are formed between movements and emotional responses. Could these associations be observed during the process of their formation in the life of the new-born infant, an opportunity would also be afforded for checking up the different stages in these processes by comparing them with the correlative changes noted in the spinal cord and lower brain-centres.

Before leaving this subject we wish to note the advantage to be derived from a confirmation of the relations supposed to exist between the cerebrum and cerebellum in controlling movement; the former is thought to be responsible for the phasic alterations in the general muscular tone which are concomitant with voluntary reactions, whereas the latter is said to exert the tonic influence dominant in automatic responses. Some of these problems might be definitely solved if particular attention were given to the physiology of the spinal cord during the first few months of extra-uterine life.

Returning to the consideration of the simple form of adjustment, the reflexes, we find these reactions indicate the existence of a short circuit in which practically no elaboration between the impinging stimulus and the almost immediate response in the form of movement takes place. The occurrence of instinctive activities reveals a greater degree of complexity in the mechanism, showing the existence of purposefulness and for this reason these responses are regarded by some physiologists as affording a marked contrast to the reflex activities. This point of view we believe to be exaggerated since the study of all primitive adjustments makes it evident that the transition from the reflex

to the instinctive level is accomplished without any break in the chain of phenomena. It is impossible, therefore, to indicate the stage at which the reflex is transformed into the instinctive activity. The difference is one of degree, not of kind.

The differentiation of sensitivity naturally stands in very close relationship to the various movements, but predicates the intervention of a definite nervous system. A primitive degree of differential sensitivity, the capacity to discriminate between sense-impressions, appears early in life. The effects of olfactory stimulation are generally very apparent in the new-born infant. Often a marked change in the circulation occurs, indicated by an increase in the pulsations taking place at the fontanelles which may even be accompanied by disturbances of the respiratory rhythm. In many primitive mechanisms there is a tendency on the part of observers to refer these without justification to the functional activity of the higher brain centres. It has been shown, for example, that newly born guinea-pigs and white rats respond very quickly to olfactory stimulation, but the study of the sections of the brains of these animals brings out the fact that at this period these reactions are dependent upon nerve tracts running from the olfactory lobes through the ganglia at the base of the brain to centres in the medulla and cord, without any connection with the cerebral cortex. (H. H. Lane.)

Taste is thought by some observers to be further developed at birth than any other centre. Studies made by Peterson and Rainey confirmed the impressions of the earlier investigators as to the functional efficiency of the gustatory apparatus even during the early hours of extra-uterine life. Individual variations as to this efficiency are, however, considerable.

The sensory development of many of the lower animals is much in advance of the human species at birth. This is especially true in regard to vision, which at first is of secondary importance to the infant, although soon after the first hours of extra-uterine life the respiratory rhythm may be

disturbed by the incidence of a bright light in the eyes. The elaborate apparatus by which vision, as well as the complicated phenomena of touch and the sense of appreciation dependent upon the evaluation of muscular contractions, comes very gradually into play.\* Acoustic stimuli often cause a slowing down or irregularity of the respiratory movements even when the infant is asleep.† In man also the changes necessary between the first indefinite efforts to avoid light and bright objects, and those reactions concerned in directing the eyes and making visual descriptions, require a considerable period of time. Sometimes if there is motor restlessness sounds of a pleasant character restore tranquillity. The significance of these early responses to impinging visual or auditory stimuli should be studied in connection with the later development of the person, since important data may be found from which a forecast of certain mental traits might be made. The degree of relative responsiveness of the two centres in the brain might be determined by a careful analysis of the early reactions to light and sound; and some idea might also be gained as to whether eye- or ear-mindedness represented the prevailing tendency. Tone perception in the human being during the first period of extra-uterine life is far below many of the lower animals. In addition to vision and hearing, touch undoubtedly plays an important rôle, and by this avenue the infant's line of communication with the external world is maintained and rapidly extended. Quick responses follow the contact with cold objects, often causing rapidity of respiration and motor restlessness. Orientation in space is probably first determined by the sense of touch, and as has frequently been said a baby soon begins to realize that the outside "world lies just beyond its finger tips." Out of these simple forms of adjustment there develops the capacity to externalize and to form various

\* Canestrini, S., "Ueber das Sinnesleben des Neugeborenen," *Monograph a. d. gesamtg. d. Neurol. u. Psychiat.* (Springer, Berlin, 1913, H. 5).

† Spindler, F. N., *The Sense of Sight. Our Senses and What They Mean to Us* (Moffat, Yard & Co., N. Y., 1917).

judgments essential for the elaboration of the space sense. Impressions transmitted from the somatic and kinesthetic areas, as these centres become functionally active, soon begin to fill the field of conscious adjustment. It is not known at what time the end organs in the muscles, serving to transmit feelings derived from the muscular apparatus, become functionally active. These particular structures are later very important factors in the development of the soul life, because they are so closely associated with mechanisms needed for the execution of movements immediately concerned in the satisfaction of very complex demands.

A more extended investigation of the genesis of sense-perception along the lines already suggested is desirable to give the key which would assist in unlocking for us many of the secrets of the complicated emotional and intellectual reactions of the adult.

The rapidity with which the infant's movements become co-ordinated is, as we have noted, an extremely useful index of the development of the central nervous system. The co-ordination is not only indicated in connection with the muscular movements of limbs and body, but also in those movements concerned in expression. The degree of co-ordination attained may be estimated by observing such acts as crying, laughing, puckering of the lips, or in the act of sucking and in primitive movements of defense, such as turning away the head from an unpleasant stimulus, etc. We do not often realize what a complicated form of adaptation is represented even by the first cries of a baby. The wide opening of the mouth for the production of sound is followed by the closing of the eyes, a reaction said to be induced as a protection against the great increase in the intra-ocular blood pressure which, if not counteracted, would be exceedingly deleterious to the delicate tissues of the eyes. We need a very much more detailed study in connection with the rapid elaboration and co-ordination of the movements of the skeletal muscles. By carefully comparing the motor responses at birth with those taking place at later stages and by observation of the various steps in



the development of function we should in time probably arrive at a much better understanding of what actually takes place as the cortex begins to assume control over those centres situated at lower levels; and furthermore, it is not improbable that if we were successful in analyzing these movements and in tracing out their relationship to each other we might come to some definite conclusion as to the nature of the correlations existing between structure and function in the mechanisms contained within the cerebral cortex. Not only the results of these investigations would be enlightening in regard to the functions of the cortex, but they would also give a much clearer idea of the relative importance and the kind of control possessed by sub-cortical areas, since these latter have attained a degree of functional value that at these early periods of life is far in excess of the cerebral mechanisms which much later become dominant.

More careful analysis of the rapidly increasing complexity of movement should make it easier for us to understand the first habit-mechanisms. The mere fact that a group of movements is repeated does not imply the existence of any complicated form of adjustment.

The relation of the special characters of a movement to the degree and kind of sensitivity exhibited is also an important field for the investigator. An incident stimulus gives rise to a response, although the intensity, duration, and number of groups of muscles involved often seem to bear only an indirect relationship to the kind of sensory stimulation. The earliest reactions to sense-stimuli are probably brought about by the existence of a general and not a specific form of sensitivity—*i. e.*, the functions are not localized. These first impressions are doubtless very vague; a relatively long period elapses before there is any evidence of differentiation and of any actual distinction between specific sense-impressions. Very closely connected with the mechanisms concerned in the production of movements, especially when several groups of muscles are involved, are those which later serve to direct or regulate the stream of attention. Even in the very first acts there is a tendency,

as we say, to focus or concentrate the activities. Sometimes we observe that when one series of movements has been initiated an impinging stimulus coming from quite another sense-area will inhibit part or the whole of the entire complex; or again, an incident stimulus may serve to fire an entire train of responses, and in this latter case there is such a rapid spread that an explosion follows. The element of fatigue must also be reckoned with. It is well to reflect upon the complexity of some of the early responses, since in such a one as when an infant follows with its eyes a bright object waved in the air there is already an extraordinary degree of association and a certain capacity for directing the flow of nervous energy. There are often decided fluctuations in the capacity to direct the energy in any one particular direction; conditions varying greatly as the result of fatigue or other causes. The spontaneity of movements also seems to vary greatly. Some infants are relatively quiet until aroused; others are constantly in motion.

Reference has already been made to the fact that some indication of the gradual dawn of self-consciousness is brought out in connection with the primitive responses of the new-born, and in the manner in which the first appearance of likes and dislikes for various kinds of stimuli are expressed in the different reactions, although some of these are undoubtedly almost pure reflexes. The initial and at first vague sense of gratification or pleasure is associated with these muscular adaptations. As the higher cortical centres of the brain are those in which the mechanisms of self-consciousness are chiefly represented, there does not seem to be any justification for referring to these primitive movements as possessing any special psychologic importance, as has been done, for example, by those who think to see in these reactions evidences of infantile sexuality. The same objection also holds good for rejecting this interpretation of such movements as sucking the thumb and of the hypothetical erotism supposed to be connected with movements of the lips when sucking, or the tendency often shown

by infants to scratch their own or other persons' faces. These acts have no special psychic value, but belong to a class of reactions which scarcely rise above the reflex level.\* So many of the infant's responses are described in terms of adult psychology that often it is extremely difficult to dissociate these phenomena from a false interpretation. Experience has shown the futility of attempting to divorce the study of consciousness from the consideration of the general biologic properties of the organism, a principle whose value is very clearly seen whenever the effort is made to trace the connections of the growing stream of an infant's activities that are just beginning to be faintly tinged with consciousness with the primitive and loosely co-ordinated responses occurring in lower levels. The results of biologic investigations have also served the useful purpose of impressing us with the unity of all the processes, and have cleared away the last trace of the hypothetical specific differences which were once supposed to create inseparable barriers between the phenomena of adult and infant consciousness, or between the latter and the automatism or reflexes.

An impressive fact derived from the study of human beings during the period of early infancy has been noted in connection with the recognition of the progressive unbroken process of integration taking place between the functions of all the different organs. We cannot say that at a particular moment in the life of an embryo functions are carried on without the participation of a nervous system, and therefore are characterized by the absence of some specific qualities always marking the entrance of these organs as directing factors in controlling the vital responses. Just as the chain of activities is rapidly extended so as to include the functions of such organs as the thyroid, thymus, or adrenals, and afterward these structures, possessing extraordinary dynamic potentialities, are silently and without any appreciable alteration included within a larger circuit of

\* V. Hug-Hellmuth, *Aus dem Seelenleben des Kindes* (Denticke, Leipzig u. Wien, 1913).

organs tending to modify and regulate the life-processes still more, so the primitive sense-impressions, without any break in the line of continuity or contraction of the ever-widening circle of responses, become elaborated and synthesized to form the immediate background out of which the elements of a primitive self-consciousness are projected. None of the vital processes, whether they be amœbic movements of cells, pulsations of the heart, reflexes, or voluntary responses, possess characteristics which, strictly speaking, may be described as specifically distinctive.

The suggestion of "purposefulness" as a sign of specificity also fails as a means of distinguishing the higher from the lower levels of activity; and the absence or presence of this quality does not, as some persons have stated, measure the degree of "the consciousizing process." For this reason we cannot estimate progress in the mental growth of a baby merely by what seems to be the increasing purposefulness of the acts. An anthropomorphic tendency for a long time prevented recognition that the elements of consciousness are to be found far down in the animal series, and the same form of spiritual myopia also increased the difficulty of recognizing the existence of the intimate bonds unifying the reactions of human beings, not only those occurring at different levels, but also those arising at different periods in individual development. Many persons were quite as unprepared to recognize the direct sequence and unbroken continuity of the chain connecting the incoördinated and apparently purposeless movements of the infant and the complex voluntary responses of the adult, as they were to admit the possibility of any close similarity of relationships between any of the mechanisms expressed in the phenomena of the personality, or those represented by the activities of a man's simian ancestors, or by the responses of a jellyfish.

The more closely we study the successive events in the early life of all vertebrate embryos, including the human species, following the period marked by the taking over by the nervous system of the control and regulation of the output of energy, the more extraordinary does the rapid

extension of the integration of functions occurring without jerks or skips seem to be; so that the whole process may be compared to the steady flow of a stream the volume of which is constantly increasing, ever gathering greater force and forming new channels for the distribution of its currents. In the early life of each vertebrate there is reproduced a complete succession of responses paralleling the stages represented in the scale of animals as far down as the amœba, but in the long phylogenetic line there is not the same degree of smoothness marking the various gradations in the complexity of responses as there is in the successive ontogenetic mechanisms which come into prominence during the life of an individual. In reviewing the animal scale it is impossible to say at what level the complex which we designate sensation first makes its appearance, although some of the elements composing it are present as soon as the transition from the inorganic to the organic world is effected. An analogous condition is found in the human embryo. So far as we know, the primitive reactions of the vertebrate embryo take place prior to the differentiation of a nervous system, and in this case the apparatus for the discharge of energy is simpler even than the arrangement in one of the lower forms of animals when a so-called sensory epithelial cell and ganglia are united with a motor cell and its ganglia, the chain ending in the muscle.

A similar neuro-muscular apparatus is found in the human embryo and probably is capable of responding to various degrees of sensitivity. Later, out of this general and ill-defined function there develops, depending upon the progressive differentiation of structure, a whole series of reactions which in their more complex forms represent the basis of an existence-consciousness. In the early stages of life of the human embryo the reception of incident impressions and the subsequent contraction of muscles occur without any sensation, but step by step, as the receptive and transmitting organs become more and more complex, the apparatus is rapidly prepared for the vague self-consciousness which dawns at birth. Even at this early stage an

exceedingly complicated mechanism is in operation. Although the number of co-ordinated movements of legs and arms is relatively a small one, some reactions, such as are concerned in sucking, have already called into activity a large number of nerve cells which probably have been prepared to function largely as the result of hereditary influences. In addition to these centres, others associated with the movements of the stomach and intestines, with the maintenance of the equilibrium, with the position of joints, are fulfilling their functions. A vast peripheral mechanism is already beginning to be a significant contributor to the background of consciousness. It is impossible to say at what moment the sense of effort in overcoming resistance or in co-ordinating new groups of muscles comes into action. Possibly it may be in connection with the sucking movements.

We are inclined to minimize the importance of the muscular system in relation to the forms of conscious adaptation. The influence of the striated muscles, with the exception of the heart, is generally recognized as an important factor, but on the other hand the smooth or unstriated muscles are usually disregarded in reference to the higher forms of adaptations; although the latter have an indirect bearing not only in preparing the stage for consciousness, but also in modifying, restricting, and rearranging its various phases when it finally appears.

The following up of the integrations forming the primitive consciousness has a marked bearing on the genesis of the voluntary activities. In the preceding chapter we have noted the first objective signs of the volitional life that appear in connection with the reactions occurring subsequent to birth and are dependent upon an elaboration of reflex and instinctive activities. As the child develops there are many movements which indicate an effort to overcome either active or passive resistance. At first these adjustments appear only in association with attempts to change the position of a limb or the body, or to resist or avert some special stimulus. Quite rapidly, however, these mechanisms are

elaborated, and soon the baby strives with greater "purposefulness" and more persistence to attain the desired result. The hand may attempt to grasp something within reach or, prompted by an inner impulse of hunger, the effort is made to get to the mother's breast.

At least three distinct mechanisms may be said to determine these early volitional responses, *i. e.*: (1) those set apart for the distribution of energy at the higher levels, including sense-organs and sensory tracts; (2) the intracerebral mechanisms; and, finally, (3) motor paths for the discharge of efferent impulses. It is sometimes possible to give a general forecast as to what the volitional potentiality of the person at later periods of life may be from results of careful analysis of these early reactions. Thus in some instances auditory stimuli fire the chain of subsequent reactions, whereas optical stimuli seem to have only a relatively slight effect as existing causes. The effect of these impressions has a very close relation to the primitive voluntary responses.

No doubt much valuable information bearing upon the later development of the personality could be obtained by carefully observing the effect both of sense-impressions and organic sensations in linking up or "lining out" associated responses. At a very early period in the infant's life an estimate of the spontaneity of the volitional processes might be made. Voluntary action may be greatly curtailed if the discharges are blocked or inhibited on the motor side. Even early in life, sometimes very much earlier than we suspect, there is evidence of a definite clash between motives. The integration in the inhibitory process varies greatly in infants and, as a rule, these phenomena only begin to attract attention when there is a necessity of choosing between two motives which involve either the acceptance of an inconvenience or unpleasantness, or withdrawal and interference with an agreeable sensation. In studying these primitive volitional reactions the attention should be tested and the distinction made between distractibility due to excessive sensitivity and that which is the result of impaired

or defective responses of the sense-organs. An infant may, on the one hand, be so hypersensitive to visual or auditory stimuli, or to those arising from organic sensations, that the state of motor restlessness produced gives no opportunity for persistent co-ordinated activities along any single line; while, on the other hand, the flood of impressions usually coming through the sense-organs may be so reduced as not to explode any of the customary reactions.

A choice between two motives can often be determined by the strength of the sense-impressions. This is very evident when we observe the manner in which babies are attracted by some brilliant object dangled before their eyes, although at the same time they may be subjected to strong auditory stimulation. The processes of adjustment may be influenced by suggestion at a very early age, as, for instance, when one baby, upon hearing another infant, begins to cry. Children differ considerably, however, in regard to the element of suggestibility, so that here again we are obliged to study the part which the terminal sense-organs, organic sensations, etc., play in control of the reaction. The degree of suggestibility increases toward the later months of infancy and soon the attempt is made to copy gestures or facial expressions. Since the whole matter of the will is largely a question of the dynamic power of the attention, a careful study should be made of the phenomena included in this category. In the infant the integration of processes making voluntary reactions possible is a subject that many psychologists have investigated, but one of the difficulties met with in presenting the subject is the adaptation of terms to give a correct idea of the extreme delicacy of the various integrations taking place as the simpler automatic responses become definitely transformed into reactions generally described as voluntary. Baldwin has given an excellent account of the genesis of these primitive will-mechanisms, and has shown how gradual the transitions are between the simple and persistent imitations which mark the beginnings of the will-life.\* There is a stage in the development, how-

\* Baldwin, J. M., *Mental Development in the Child and the Race* (The Macmillan Co., 1897).



ever, which is on a still lower plane than the imitative period, and corresponds with the first efforts to overcome resistance. Possibly the simplest example of this that occurs to us is when a movement of a limb is begun but is blocked by the interposition of resistance. The impulses generated within the infant's nerve centres may be sufficient to urge progression merely by the new impetus acquired. There may not, probably is not, the slightest effort made to complete the series of movements, but the renewed attempt to drive ahead may be simply due to the surplus energy which has been accumulated in the nerve cells as the result of the sudden block. The second drive forward which follows a slight pause may be a "kick-back" from the centres involved. This second stage, a little more advanced, very often develops when a movement is checked by opposition, to begin again after a slight pause due to the accumulation of fresh energy for discharge. We can conceive of these processes varying in all degrees. Sometimes the firing of the second charge is immediate, or there may be considerable lengthening of the intervening period of rest. Finally, there is a very fine distinction to be drawn between delay for a simple period of rest and the delay associated with an element of deliberation and choice. Here again, when we attempt to build the bridge between the two, we are met by the relatively few details which have as yet been recorded.

The phenomena of the memory are both general and special. Under the former is the group which we designate as organic memory, relating to the entire growth and development of the organism; while under the second head are those phenomena commonly described as psychological memory, and to those, since they have an important bearing upon the development of the personality, brief attention will be given.

The various mechanisms concerned in psychological memory have been classified by Stern,\* and his groupings, slightly modified, are as follows:

\* Stern, *opus cit.*

Purely automatic recalls.	1. Depending on general sensitivity.	Association by contact. Association by similarity.
	2. Recall suggested by primitive idea.	Consequence of Association. Cropping up "free." By
Specifically conditioned recalls.	3. Recall provoked question.	
	4. Definitely conditioned by will.	Will to direct attention. Will to recall.

There are two factors in the psychologic-memory mechanism which deserve special consideration. In the first place we have to consider the primary act of reception or picking up of an impression and its retention by the nervous system; and in the second place the phenomena of reproduction or recollection. In the study of the former we have to take into account the sense-organs and the paths connecting them with the brain, to form an estimate of the capacity of this organ.

By a careful study of the functioning capacity of sense-organs we may get some clue as to the general character of the infant's memory; that is to say, we may be able to detect the form of stimuli which seems to impress itself most effectively upon the special nervous system. We do not as yet possess any method by which the reproductive capacity of the brain for sense-impressions stamped upon it may be estimated. Indirectly we may obtain a general idea of the type of memory by the observation of the functional capacity of the sense-organs and so estimate the latent period occurring between the incident stimulus and its reproduction. Sometimes in the case of mental defectiveness the act of reproduction is delayed by retardation in transmission. In investigating the subject of memory in very young children it is well to remember that many links in the process are still unknown to us. Various emotional trends and undercurrents drive, as it were, certain portions of the whole train of associative memories into the foreground so that the child gives objective expression to

these. The important part played by the emotional undercurrents in reproducing memories of past events is demonstrable. During the latter years of childhood some events which have taken place early in life stand out with considerable clearness. Often these memories relate to occurrences or persons that an adult person would have thought not likely to impress strongly the child's mind. Again, the importance of the occasion as it is remembered seems to depend entirely upon the emotional undercurrents. Impressions are recalled that are associated with events with a strong emotional setting. This is well illustrated by an anecdote told of Wagner. One of his earliest recollections was the memory of some one playing the piano in a room adjoining the one in which his stepfather was dying. The young Wagner was greatly impressed by overhearing his stepfather say that "Some day the boy might become a musician." Not only the strong emotional reactions taking place at the time of this event, but the subsequent struggles of the young musician to attain professional success tended to keep this memory from passing out of the field of consciousness.

According to some observers the acts of memory in which definite volition becomes a factor in the act of recall generally begin about the third year of life. This, however, is a purely arbitrary assumption, and at once raises the question as to the nature of the adjustments designated as volitional. About this time the child commences to show a capacity for distinguishing between true and false reproductions of memory. One important factor in determining the character of infantile or childish memories may be found in the organic sensations. Often at a very early age these begin to play a large part—as is indicated when there is evident gratification associated with certain activities. The complex sense of well-being which is dependent upon the memory of antecedent events is an important element in the foundation of the personality, and may be studied to advantage while it is in process of formation. It is desirable to trace the relationship between the discharge of nervous

energy in the form of muscular reactions and the accompanying states of gratification, dissatisfaction, or pain, because these reactions in the child are so much less complicated than are those in the adult. Gradually, in the course of normal elaboration of these reactions, as the muscular system falls more and more under the control of the brain and both the sensing of activities and their co-ordinations become greater, there emerges the complex of responses which we recognize as the first indication of the dawn of self-consciousness. The experience essential for the birth of the idea of personality is acquired slowly, and the first verbal reference to it is to a third and not the first person. The more regular the development, the more difficult it is to state at what moment this elusive complex is formed. Ideas of time and space do not form early; the period when the baby learns to recognize persons and things comes first; but at the same time there have developed some of the vague emotional reactions to which allusion has been made. The idea of self emerges gradually from the vast background of reflexes and automatic reactions, as opposition to responses is gradually aroused; as, for example, when an infant reaches for an object it has been forbidden to touch. The first signs of appreciation of the pleasure of eating forbidden fruit are often quite apparent from the changes in behavior, although when these reactions first make their appearance they are less easily recognizable and are less complex than the responses taking place under similar conditions in an intelligent dog.

It is said that before a child is one and a half years of age there are generally present signs, vague at first, of a sense of honor and ambition. Attention has also been directed to the importance of close analysis of the primitive sense of shame—usually first recognized when in the presence of strangers. The genesis of this particular emotional reaction is attributed by some to sexual influences, but the majority of those who have given attention to this subject think it due to other causes.

The affections, a generic term for a certain group of re-

actions, soon begin to be represented in the behavior of the infant. The baby, at a very early stage, is attracted or repelled by certain persons, although the general sense of familiarity enters very largely as a prominent factor in this special response. The early antipathies are often exceedingly interesting and deserve careful attention. Sometimes it is possible to detect evidences of the crystallization of certain reactions which if left unchecked may later in life lead to the development of undesirable traits.

The effects of suggestion in modifying reactions as well as the gradual development of a genuine sense of sympathy have often been noted, even at very early periods. In regard to the former it is frequently observed that the element of suggestion at first seems to be stronger in the reactions accompanied by a sense of pleasure. The baby readily learns to imitate the sounds made by parent or nurse.

It would be extremely helpful in understanding the mechanisms entering into the composition of the personality if the genesis of these primitive reactions could be more carefully traced, and the fundamental relation existing between the emotional and intellectual life were worked out; that an intimate connection does exist there can be no doubt. The numerous lines of communication between sensori-motor and psychic areas in the cortex with the centres in the base of the brain and medulla are evidences of the intimate dependence of all these activities.

In the normal development of speech we find an interesting index to a number of the most important epochs in the growth of the personality. In the first period, corresponding with the first year of life, there occurs the production of single sounds, which is soon associated with an effort to imitate; and then later a faint trace of the understanding of expressed commands. From the close of this period, for the succeeding six months, the child uses short sounds with vague and ill-defined significance. These expressions have more the character of symbols than of definite words; the formation of ideas is not yet possible. Between eighteen

months and two years of age the idea is grasped that things have names, and voluntary efforts are made to learn the names. The vocabulary grows and monosyllabic sounds and words begin to show some arrangement in the order in which they are used, until finally short sentences are formed. Substantives, verbs, and adjectives are usually adopted for use in the order given. At the age between two years and two years and six months the arrangement of the parts of speech is more definite, and there is a more complete adjustment of the words used to express ideas. There appear also the various elements of grammatical arrangement in conjugation, and comparison by the use of adjectives. The period of active questioning begins.

The last period marks the transition from the parataxic arrangement of words to a true hypotaxis. The more complex co-ordination of thoughts and words in sentences is of course reserved for a much later period, but the essential ideas of language and its general significance have been grasped before the child has reached the middle of the second year. A very careful study is needed of the variations occurring in a great many children in regard to the relative length and time of development of these periods.

It is impossible to give more than a very brief notice to the value of a careful study of speech as an indication of the stage of mental development. The subject is one which has already received considerable attention, but there are still many interesting problems connected with it that need elucidation. The knowledge already obtained is useful not only in measuring the progress of functional growth, but is of service as a means of assisting in the detection of mental deterioration brought about by disease or the general involuntary process of old age. It would be extremely interesting to know more in detail about the growth of the normal child's vocabulary, and to determine if possible the laws that create the need for the different parts of speech. An indication of the significance of the mechanisms called into play in the expression of moods, tenses, attributes, verbal relations, etc., would undoubtedly add to our knowl-

edge in regard to the growth of personality. Southard emphasized the significance of the study of language in the expressions of imperfect adjustments and the manner in which the use of the parts of speech may serve to bring out the difficulties of expression. Recently this line of investigation has been undertaken by carefully analyzing the speech of a number of adults chosen from different walks of life; represented by the scholar at one end of the line and the man engaged only in manual labor at the other. In giving short accounts of their life histories it became evident that the use of a large proportion of nouns was characteristic of persons possessing the higher grades of culture, while comparatively few adjectives, prepositions, and conjunctions were used. In the illiterate group there were relatively fewer of the noun-adjective group but relatively more of the verb-adverb class. In the comparison the variety of words used by intelligent, cultivated normal persons and children, with patients suffering from the various forms of psychoses, affords data for instructive deductions. More accurate information on this subject will doubtless add something of importance to the tests for estimating the degree of intellectual development; although of course the general environment, social standing, and educational advantages are modifying factors, which should always be taken into account.\*

In a very imperfect manner we have attempted to point out the various factors involved in any estimate of the rate and extent of the growth of personality. Numerous other facts are necessary if these evaluations are to become of greater practical worth. The problems presented are very complex and demand careful analysis of all the factors. We should not be satisfied with the study of the innate conditions, since these cannot be interpreted correctly without referring them to the constant changes in the environment. This principle is well illustrated if we consider the elements leading on the one side to the development of a normal, well-balanced personality, and on the other to one rendered

\* M'Donald, W. M., Jr., *J. Nerv. & Ment. Dis.*, 1915, XLII, pp. 482-540.

defective by the influence of environmental factors. Our egoism frequently leads us to discard the latter as of no importance. Individual lives show the intimate dependence of both sets of factors. Two boys with apparently similar endowments turn out differently; and those persons who give little attention to these questions show amazement at the results. A grasp of the real significance of the extreme delicacy of adjustment between external and internal conditions will place us in a position to comprehend the nature of the reactions represented by conduct. If one person previously weakened by an illness were exposed to the blinding glare of sunlight upon snow-fields the sense of discomfort and subsequent derangement of vision would be more acute than in the case of a strong, vigorous man. Exactly the same principle holds true in regard to behavior. If the adjusting capacity of a youth is temporarily lowered by accident or disease and the undesirable influences of the environment happen at this particular time to be concentrated upon him, then habits of response which are less favorable for the development of temperament or character will be formed, and in this way the environment is set against the person, giving rise to a cumulative series of unfavorable reactions. There are many examples met with in daily life which demonstrate that a condition of hypersensitiveness to stimuli has been aggravated and the attendant undesirable habits called forth by this condition have been crystallized by subjecting the person to the constant pressure of unfavorable influences.

Thus around the primary instincts acting as nuclei, there have been organizing a subsequent chain of reactions expressed as emotions, sentiments, and those permanent motives which may be recognized as signs of degeneracy and mark a freedom from the ordinary inhibitions essential for the protection of every one from the inclination to resort to perverted and criminal practices. Unless we are careful to provide the conditions necessary for healthy growth the artificial environment set up by society will make it easy for children to follow a line of minimum resistance where



the growing intellectual activity does not gain any predominance over the instinctive life. The constant repetition of certain acts leads to a form of automatism with the result that eventually there is little control and little incentive to call forth initiative and will.

If it be true that civilization has paid a very heavy penalty for neglecting to study the "inner causes" which determine the growth of the personality, we should not rush to the other extreme of neglecting the consideration of environment, and view the human machine as if its activities were carried on without modifications imposed by an external world. For this reason it is desirable to avoid subjecting the child to those influences which in the long run tend to introduce discordant elements and to destroy the balance of the personality. We now need very especially close, intensive, co-operative investigations of the many problems relating to the development of the personality through a combination of forces made up of psychologist and physician, who should be given every opportunity for their research in the pediatric clinics and in departments organized for the study of the normal as much as of the subnormal child.

## CHAPTER VI

### ORGANIZATION AND SYNTHESIS

(TEMPERAMENT, CHARACTER, AND INTELLIGENCE)

THE condition we call health marks the balance maintained by the living organism between the processes concerned in the production, transformation, and discharge of physical and mental energy. The better the health the more complete is the degree of organization of the various activities.

Any attempt to judge or rate a personality involves the consideration of two groups of organized adjustments, collectively designated as action and thought. One group of functions is often referred to as character and the other as intellectuality. An analysis of both groups of these functions gives some idea of what Clouston once called "the native basis of mind." In health a balance is preserved between these "two inextricable components of mentality":\* character including the emotional adjustments usually described as moral force and stamina, while intellectuality embraces ideational presentations and forms of rational thought. Character supplies the energizing and driving forces and is the executive department in contrast to the judging, deliberating, and inhibiting influences emanating from the judicial department, intelligence.

Temperament represents one phase of character measuring the extent of the organization of activities and reflecting, as Warren points out, the hedonic attitudes. A study of temperament throws important light upon the foundations of character: a group of functions responsible for the efficiency and excellency of the personality. Temperament, character, and intellectuality all represent different aspects of the biological organization.

\* Fernald, Guy G., "Character as an Integral Mentality Function," *Mental Hygiene*, July, 1918, vol. II, no. 3.

The approach to the study of temperament, character, and intellectuality by considering them in the light of the general biologic law controlling the organization of activities in every level, whether reflex, automatic, or mental, has been found to be the only sure and comprehensive method in exploring the personality. "We are only just beginning," says Parker, "to learn that an organism in its essentials is an active working system, and that the moment we think of it as a machine standing still we divest it of precisely that element which is most distinctive of it."

In order to understand the nature of the human personality it is essential to distinguish carefully between the elemental and organismal conception of any living organism, whether it is a plant, animal, or man.\* The elemental or analytic process is invaluable in studying the functions of different parts of the machine, but the conduct of the machine as it is actually engaged in the task of adjusting its life requires to be considered from the synthetic point of view, which describes the organism as a living working unit. This is a simple, almost self-evident truth, but on account of his lack of perspective it has been exceedingly difficult for man to appreciate its importance.

"The organism in its totality," says Ritter, "is as essential to an explanation of its elements as its elements are to an explanation of the organism." When we begin to investigate the higher forms of adjustment—reflex, automatic, and conscious—this principle has a special significance. For, just as it is impossible, as Sherrington affirms, for the physiologist to understand a reflex without knowing its aim, it is equally clear that analysis alone cannot give us any true idea of the biological adaptation of human beings. No mere aggregations of ideas or emotions can give satisfactory explanation of adjustments at the conscious level. The behavior of a living organism cannot be expressed merely as the algebraic sum of its constituent parts.

\* Ritter, W. E., *The Unity of the Organism, or The Organismal Conception of Life* (Richard Badger, Boston, 1920). White, W. A., "The Unity of the Organism," *Psychoanalytic Rev.*, VII, no. 1.

The dogmatism of the analysts has been as serious an obstacle in the way of arriving at a satisfactory common-sense conception of human behavior as the erroneous conceptions of the mystics. For example: in what *we know* from actual experience about the behavior of a certain investigator is found the clue which supplements the information we possess in regard to the significance to be attached to the disordered functioning of some of his internal organs which are not performing their functions properly and cause a certain amount of irritability of the nervous and hypertension of the muscular systems. In the light of this practical example it is easy to understand to what an extent the elemental physiological reactions, such as neural irritability and muscular hypertension on the one side and the emotional and intellectual processes on the other, are mutually explanatory.

As a matter of fact we cannot understand the dysfunction of any organ until we have made clear the part that particular organ plays in the general synthesis of functions collectively designated conduct; neither can we understand conduct until we know something about the degree of efficiency of functions of the component parts of the organism. By recognizing the synthesizing capacity of the organism as well as the continuity of all the different processes there is less inclination to emphasize the artificial distinctions so long represented by a certain school as characteristic of emotional and mental reactions so that in many instances the divisions came to be regarded as indicating entirely separate and unrelated functions. Not infrequently investigators have been led astray into accepting deductions based upon the analysis of what at the time appeared to be striking examples of so-called mental "associations"; and this assumption led to the substitution of "casual and unmeaning for serviceable connections."\* For similar reasons investigation has been hampered by the arbitrary attempts to limit the discussion of mental adjustments to the

\* Shand, A. F., *The Foundation of Character* (The Macmillan Co., London, 1914).

functions of the brain only. Practically no attention was given to the fact that such organs as the liver, suprarenals, thyroid, and sexual organs, by the effect of their secretions upon the activities of the nervous system, influence the sequence of our moods, trains of thought, and general trend of activities.

In admitting the effect of internal secretions in directing the emotions and giving shape to the personality, we are practically reaffirming belief in the ancient doctrine that temperament, the peculiar physiological and mental make-up characteristic of a person, was due to the predominance of certain humors. To-day it is known that secretions, containing autocoid substances, products of glandular activity, profoundly influence the emotional status and in this way control the personality.

We need, then, both an elemental and a general organismal point of view to get a really comprehensive idea of the stream of vital energy which is constantly ebbing and flowing; causing at one moment an adjustment at reflex or at automatic levels, or interposing a process of digestion or an intermediary process of thought between the incident stimulus and reaction so that "feeling and experience are chewed and transformed into the stuff whence action is made, into the supposition, the belief, the conviction upon which action proceeds."

The rise and fall in the tide of energy is part of the process of adaptation which includes two sets of reactions—one tending to preserve the unity of the organism, while the other is the tendency of functions of different parts to assert themselves. Dissociation arises as soon as the resistance to unified activity is disturbed either by the over or under functioning of any of the parts. As Janet\* pointed out, fluctuations in the current of energy represent many different degrees of activeness of the various tendencies. It is impossible to explain the large number of varieties of behavior occurring in one person if it is assumed that the

\* Janet, P., "Les oscillations de l'activité mentale," *J. de Psychol.*, 15 janvier, 1920, XVII, Année no. 1.

tendencies and dispositions always react in the same manner to incident stimuli. A good deal of light may be thrown upon human conduct by analyzing the degrees of activation, taking note of the ebb and flow in the tide. In all reactions there is a state or period of latency during which a given tendency does not function merely because the external or environmental conditions supplying the necessary stimulus are not present. We do not drink because we are not thirsty, and do not eat when hunger is not present. There are also conditions in which the tendency remains latent although the customary stimulus may be present; in this case the usual reactions and syntheses do not form. In another condition the tendency itself is preparing for action without actually accomplishing it and occasions a series of movements which are not the habitual forms of reaction. This state of preparedness is marked by a rise of tension. If the tension is diminished there is a loss of interest, mental distraction, and a decided sense of *ennui*. Any tendency arrested during the development of the process of activation springs upon the attention a course of action reflected by some unfulfilled wish. The purpose of the projected course of action is a wish, and in attempting to explain the phenomenon, as Holt has reminded us, it is of really little importance whether the purpose is being merely entertained or executed. Incomplete realization may be indicated by the appearance of movements characteristic of the tendency that was developed irregularly and was first opposed and later assisted by the simultaneous development of the other tendencies. All these reactions are the result of the disturbance of the balance maintained by the living organism between external and internal conditions. Either following the action, or at the moment of action, an adjustment takes place which tends to re-establish the equilibrium. Different tendencies responsible for these reactions may be expressed by special movements or by the readjustments effected through the muscular sense, at lower levels, or at higher planes by the intellectual processes.

The value of consciousness in these reactions lies in the extension of the range of adaptation, so that the ill-defined but pressing need is symbolized in concrete form; and an idea is given of the significance of the action and of the object of the desire. It is not necessary to call attention here to the infinite number of possible variations of the desire. The repression of one desire by another or the substitution that often takes place is a very interesting part of the phenomenon. Personally we object to the use of the words suppression and repression in this connection because ideas they express do not seem to correspond with the little already known in regard to the physiology of volition. It is an accepted fact that when two or more impulses are struggling for domination the stronger one finally obtains control of the common path and excludes the others. This is a process of shunting or side-tracking the weaker impulse, but is not in any sense an act of suppression or repression.

The stream of energy, the oscillations of which we are now considering, flows constantly in the direction from the lower instinctive levels to the higher levels. When one impulse succeeds in controlling the common path it presses upward from below, sometimes rising like the water in a well to one level and then another, side-tracking other impulses which are opposing it. As far as we are able to judge, it is the drive from the lower levels that decides upon the selection of paths in the higher planes. This process of side-tracking, not suppressing or repressing, impulses fits in better with what we actually know in regard to the physiology of the voluntary processes.

In the case of the psychological adjustments we have two important factors to consider. On the one hand we have what Janet has called the psychologic force measured by the force, number, quickness, and duration of movements and actions. On the other side we have to consider the psychological tension depending upon the position occupied by the particular tendency in question at the time it is singled out for reinforcement from the group of tendencies which have been stimulated but have failed to de-

velop. Tension and force are two closely related factors in the reaction; and the degree of psychologic efficiency depends upon the successful combination of these two factors. As this relationship is constantly subject to change, the degree of efficiency also varies. By the study of these variations much valuable information may be obtained of the modifications taking place in both normal and pathological conduct.

In a large group of cases we find a lower degree of efficiency often illustrated by the symptoms of patients suffering from various depressed states. In sadness, for example, there is a general lowering of the tension, interfering with the function of activation and marked by a diminution in the quantity of action, accompanied by reduction of the capacity of invention, originality, and a general lowering of the adaptive capacity. In the opposite state, in which the sense of triumph is prominent, there is almost a complete change in the entire picture. In states of mental depression acts are accomplished, but as energy has been used so economically there is no rebound and the person does not experience a sense of joyful activity and accomplishment. In depression it is also natural that a train of ideas suggesting the uselessness of action and a general lack of interest should develop. When, however, the diminution of the quantity of the available force is not in proportion to the lowering of the tension, various forms of agitation and uncertainty about the future may take possession of the personality. In certain cases of laziness, it is very often true that "history plays a large part in the thoughts of the lazy person." Ideas supplied by the imagination act as compensatory substitutes for lack of efficiency in action. Since action is difficult and imagination active, the temptation of the lazy person to lie represents a partial and easy solution of a difficult problem.

In order to understand the part that the emotional reaction plays in organization and dissociation, it is important to remember the fact that the phenomenon called emotion is only one aspect of an internal adjustment made



by the organism in order to adapt itself suddenly and completely to some change in its environment.\* The function of any emotion is to reinforce interest at a critical moment when stereotyped forms of reactions begin to check the process of adjustment. The bodily concomitants of the emotion are means of enabling the organism to utilize all its available energy so as to reinforce the instinctive processes. The two centres in the nervous system, then, which are more or less in opposition to each other are the optic thalamus, which in a general way is the centre of consciousness for the emotional state, and the higher centre of control located in the cerebral cortex, which calls discriminative activities into action in order to make provision for regulating the instinctive life.

The process of dissociation is merely the obverse side of the integrated activity. Dissociation may take place at any level at which, phylogenetically or ontogenetically, integration has been brought about. The energy of the instinctive process can find an outlet along psychically equivalent paths, but any obstacle which diverts the stream from finding appropriate channels of discharge leads to the displacement of the affect and its separation from associated ideas. The more nearly the newer path for discharge resembles those followed by older instinctive reactions the easier is adequate expression found. In this principle we find an explanation of the fact that in the physical struggle taking place in athletic sports there is generally less tendency for acrimonious and vituperative reactions to persist than there is following some important debate.

No well-informed person would think for an instant of questioning the serious effect upon the organization, of activities produced by disease of such organs as the liver or adrenals, or by general infections such as tuberculosis. In every-day life we accept the fact that the highest syntheses essential for the recognition of moral and intellectual standards suffer rapid deterioration as the result of physical

\* Carver, A., "The Generation of a Control of Emotion," *British Jour. of Psychol.*, Nov., 1919, X, part 1.

changes. So when dealing with concrete cases and clearly defined situations the working hypothesis of the modern student is that conscious adjustments can only be understood when considered in relation to all the other reactions in the subconscious levels.

The advantage we gain from the knowledge of the laws of general biology applied in formulating the problems of adjustments makes the approach to the study of these phenomena possible from a much broader angle than was the case when the incursion of the biologist into the field of psychology was an event of rare occurrence. Merely from the reformulation of some very old problems a new and more encouraging outlook has been obtained.

The question of organization of activities involves the consolidation of two sets of forces or rather two phases of the same force, constructive or destructive, anabolic or katabolic, since these are constantly operative in all living organisms; but it is with the former that we are now chiefly concerned.\*

When adaptations in the conscious levels are spoken of as superior systems and when the impression is given that these superior systems are quite distinct from all other vital phenomena, we hark back to the conventional and historic bias—a product of wishful thinking—that affirmed the complete autocracy of mind; whereas the biologic method of studying the personality stresses a certain degree of unity as maintained between the chief mental and physical functions of any living organism. This unity is as apparent in the homogeneity of the personality as it is in the general processes of growth and development or in the forces which secure protection for the organism against hostile influences (antixenism). The distinction sometimes drawn between what we suppose to be purely biologic adjustments and the so-called “higher functions” thought to be specifically characteristic of the mental life (idio-kinesis) is an artificial one.†

\* Tardieu, E., “La Méchanceté,” *La Revue*, 15 juil., 1914, Paris. Feissinger, C., *Les Maladies des caractères* (Perrin, Paris, 1916).

† Elder, M. D., *War-shock* (Heinemann, London, 1917).

In attempting to analyze the organization of reactions expressed either as temperament or character we realize immediately the inelasticity of terms when these are expected to give an idea of an infinite number of variations occurring in all processes. The mere repetition of such terms as "impulses," "emotions," "sentiments," "consciousness" serves to recall the arbitrary distinctions created in the attempt to designate processes with fixed symbols, processes themselves constantly varying in intensity and duration. This difficulty is not so marked when the organization is limited to the range prescribed by the inherited neural mechanisms and the responses are confined to the instinctive level. In the instincts the major part of the reaction depends upon mechanisms representing transmitted qualities; and only a small part of this particular form of organization is affected by modifications occurring subsequent to birth, so that the factors to be considered are relatively constant. In man the part of the nervous system participating in the instinctive adaptations includes the peripheral tracts, sympathetic system, spinal cord, medulla, cerebellum, and the great ganglia lying at the base of the brain, while the masses of tissue in the cerebral hemispheres superimposed on organs of more ancient lineage are the stations responsible for voluntary reactions, and these responses are capable of being profoundly modified. It is almost impossible to find terms suitable to describe the reactions covering such a wide range and subject to such frequent and varied modifications.

Pleasure and pain afford some idea of how affective processes, as well as those connected with rational thought, are organized around a nucleus to form complexes. It is a mistake to attempt to resolve either the affective or rationalizing processes into separate and distinct elements. Adaptations either at the affective or intellectual level represent different aspects of the same stream of energy, which is flowing on continuously, never halting for a moment but continually seeking for some outlet of expression. In either pleasure or pain the feeling processes, as we prefer to call them and not feeling elements, are very closely connected

with the higher conscious adaptations. Although they show a certain degree of apparent independence and detachment, they are inextricably connected with the cognitive and conative processes.\*

The feeling process aroused by any sense experience may depend, as Wohlgenuth has stated, upon one or more attributes of that experience. Pleasure and unpleasure seem to be the more or less specific qualities of the feeling processes and the change from pleasure to unpleasure does not seem to imply the existence of a neutral or transition phase. The low intensity of the processes collectively described as a sensation generally results in unpleasure represented by some form of disappointment. Wohlgenuth believes that the disappointment is practically an unpleasant experience due to the absence of something that was actually expected. In the case of auditory experiences the intensity of the pleasurable element may increase while the sensation decreases. There are very great individual differences in the experience of fluctuations of the cognitive contents and their feeling accompaniments. And it is also true that great individual differences exist in the experience of organic sensations attending sensory or other processes. The thoughts and ideas gathering about any sense experience sometimes may but often do not influence the affective processes gathering around that particular sense experience. As would be expected the character of the ideas in any state of expectancy are largely influenced by the feeling of the anticipated event. There does not seem to be any fixed relationship between the feelings of a sense experience and those of any associated idea called up by that particular event. This apparently confirms the impression that the processes active in feeling do not seem to assist in the recognition of the sense-impressions with which they are associated. The connecting link between these two groups of processes is the cognitive and not the affective reaction. We consider it very doubtful whether the evidence justifies

\* Wohlgenuth, A., "Pleasure-Unpleasure," *Monograph Supplements, Brit. J. Psychol.*, 1919.

the statement made by Wohlgemuth and other observers that opposite feeling elements may fuse, producing neutralization. If this were true it would be possible to believe that there is a neutral or transition stage. There is no doubt that the processes associated with feeling often are distinctly localized. The ability to localize these reactions depends upon a number of obscure factors, but the ability may be greatly improved by practice. There does not seem to be anything on "the affective side of consciousness to correspond with the memory image on the cognitive side." The affective experience associated with a recollected cognitive experience seems to be a new combination of processes and gives rise to a new pleasure or its opposite. As far as we know it is impossible to distinguish between the feeling element of the sensation and that of the memory image of a sensation. It must be true that one feeling may be compensated by another without the quality or intensity of the former being changed, although the cognitive phase of the entire experience is modified. This compensatory reaction is well worth further study, as it seems to play a very large rôle in connection with all processes in which pleasure and pain are introduced. Undoubtedly the ability to form these compensations has an important influence in limiting the entire organization of experiences. In cases of disease the compensatory reaction is not present.

In the synthetic phenomena ordinarily described as memory there is an excellent opportunity to study certain phases of the general arrangement of activities and the close reciprocal relations between a great many different functions. The apparent unity of acts of memory is often misleading, since its apparent simplicity conveys an erroneous idea as to the real complexity of the response and the number of factors concerned in the final response. Therefore it is well to begin the study of memory by recalling that psychologic memory is inseparably connected with organic memory, the former being in reality an outgrowth of it, or, as Ribot has stated: "In its essence memory is a bio-

logic and by accident a psychologic fact."\* The entire process contains two distinct phases recognized since Aristotle as conservation and reproduction.

In organic memory certain effects tend to persist and this suggests habit; but no doubt it is true that "Habit should be defined by memory and not memory by habit."† The form of organization in organic memory is quite distinct. Organic memory is memory without conscious adaptation, its manner of securing adaptation having been compared to the groping of a blind man as he feels his way; in contrast to the rationalization characteristic of a person going straight to his goal by utilizing data supplied by vision. In making distinctions between the two forms of organization we should not assume any enormous superiority for psychologic memory, since as a matter of fact the actual direction and control of behavior are probably more directly and extensively influenced by organic memory. We are likely to overemphasize the importance of psychologic memory in co-ordinating our activities, and greatly to underestimate the immense directive force of impressions that never come within the field of consciousness.

As the word memory is usually used it relates to certain functions which are part of a general system. It is practically impossible to think of memory as apart from the personality. The synthesis of biologic reactions collectively designated memory represents a conciliation of two opposing tendencies, one by which the ego detaches itself from the Past, and the other marked by the tendency to appropriate the Past and make it part of the personality. In a certain limited sense, then, memory is the personality. Consideration of all the intimate relations of memory will bring about a fuller realization of how strongly these functions bear upon the foundations of the personality complex. In disorders of the memory the more highly organized sentiments, those associated with the impersonal and disinterested motives, are the first to disappear, followed by the

\* Ribot, *Les maladies de la mémoire*, 4 ed., p. 1.

† Dugas, L., "La mémoire et l'oubli," *Bibliothèque scientifique*, 1917.

loss of altruistic tendencies. This order, however, has its exceptions, as there may be a loss of the less highly organized memories. Dugas, for example, reported the case of a musician, a patient in a hospital, who while retaining his ability to play the violin, needed constant watching and was incapable of taking care of himself. In such cases habits formed under strong emotional impressions are likely to outlast even reactions that are very close to instinctive responses.

The many difficulties of investigation of synthetic phenomena have sometimes been increased by the selection of only special phases for study; while others have been ignored, with as a consequence a wrong perspective of the whole subject.

In health the adjustments collectively referred to as mind represent a harmonious synthesis. Perceiving, feeling, willing are phenomena which depend for their existence upon the presence of the lower and general physical activities of the body quite as much as upon the higher brain functions. The reactions of living beings, whether in higher or lower planes of activity, are all a part of the phenomena of life, and their desistence is indicative of death. My perception of the color blue, my sense of pleasure and gratification, my trains of thought, judgments, desires, volitional acts, depend not only upon the activity of the sense-organs, brain, and nervous system, but upon countless other factors that bring about the organic synthesis of mental and physical elements; and the special characteristics of each person measure the degree of systematization or synthesis that exists between all the various elements. The purely psychologic theory of mind takes no account of a most important aspect of mind, namely, that it expresses an organic synthesis. For instance, the touch I experience of a feather predicates not only functional activity of brain and nervous system, but also pulsations of the heart, respiratory activity, secretory processes of internal organs, and the changes occurring in different tissues. The sensation becomes sharper, the mental syn-

thesis more distinct, if the touch falls within the dynamic synthesis recognized as the focus of attention; and it may be ignored, if not unnoticed, when a stronger stimulus occupies the field of consciousness. As a matter of fact, the gentlest touch, the sharpest pain, the balanced judgment, the loftiest aspiration, represent expressions of an organic synthesis which is so subtle that no one has ever been able to detect, nor probably ever will detect, the point at which the so-called physical becomes a part of the so-called mental synthesis.

There are phenomena called synæsthesias which might profitably be studied more closely in order to form a clearer idea of the manner in which certain important parts of the emotional and mental synthesis are blended. We should know, for example, to what extent stimulation of one sense calls up associated sensory phenomena; why certain sounds may call up definite colors; the sound of the trumpet, for instance, suggesting scarlet. It has been suggested that these syntheses may represent a confusion of sensory qualities and are not clearly distinguishable from the feelings accompanying them.\* The action of all stimuli is, of course, at first localized at the point of entrance into the organism, but in normal conditions radiation from this spot follows the incidence of the initial stimulus; and the character of the final synthesis depends upon a number of conditions, such as the receptive capacity of sense-organs, the degree of conductivity of the nerves, and the functional activity of the various centres. In studying sensations we are too much inclined to approach the subject only from the elemental and ignore the organismal point of view.

The nature of some of the syntheses formed after the excitation of sensory organs is indicated in the following table from Hollingsworth and Poffenberger:

\* Hollingsworth, H. L., and Poffenberger, Jr., A. T., *The Sense of Taste, Our Senses and What They Mean to Us* (ed. by Dearborn) (Moffat, Yard & Co., 1917).



Order of Æsthetic Value.	Number of Discriminable Qualities.	Sharpness of Discrimination.	Average Speed of Reaction.	Average Duration of a Sensation, Degree of Inertia.
Sight.	About 40,000.	Difference of 1%.	.189 sec.	About .030 sec.
Hearing.	" 15,000.	" " 33%.	.146 sec.	" .002 "
Smell.	Nine classes, each with hundreds of qualities.	" " 25%.	Difficult to determine.	Very long and difficult to determine.
Touch.	Three or four classes with qualities not easily determined.	" " 33%.	.149 sec.	.001 to .002 sec.
Taste.	Four classes with number of qualities not determined.	Doubtful.	.300 sec. to 1.000 sec.	Very long and difficult to determine.
Kinæsthetic (Movement, Strain, etc.).	Four or five classes with number of degrees not determined.	Difference of about 5%.	Difficult to determine.	Undetermined.
Temperature.	Two classes, degrees not determined.	Variable and difficult to determine.	.150 sec. to .180 sec.	Difficult to determine.
Organic.	About six classes.	Unknown.	Unknown.	Unknown.

Reproduced from *The Sense of Taste*. Moffat, Yard & Co., 1917. By permission.

Not a few suggestions have been made as to the variety of factors to be taken into account in analyzing the reactions starting from sensory impressions and ending in some form of the higher intellectual adjustments. Thus it has been shown that the æsthetic value of sense-impressions is inversely proportioned to the degree to which they arouse distinct and strong feelings. This is partly because of the fact that all intense emotional reactions narrow the general range of impressionability.

The effect of the selective activity of end-organs in shaping to a considerable extent the character of the mental synthesis is illustrated by conditions occurring in certain forms of disease. Anæsthetic areas give rise to ideas that limbs or other parts of the body may be dead. A delirious patient with anæsthesia of the legs and arms believes himself dead and buried, but, as the local disturbances subside he declares his own bodily resurrection. In these and similar cases the defect in the functions of peripheral organs undoubtedly influences the form and significance of the subsequent synthesis.

Although most well-informed people readily admit that abnormal phenomena cannot be correctly interpreted without taking into account the functional capacity of the nervous system, a similar relationship is not always granted when they attempt to explain the form and sequence of activities classified as normal. But even in normal conditions the influence of sense-organs and peripheral tracts has to be reckoned with, although correlations between incoming impressions and mental reactions are then much more difficult to establish. However, since individual characteristics of each mechanism are determined by biologic principles, we must beware not to overemphasize the immediate effect of the peripheral elements in ordering the responses, since even without the immediate localized interference of sense-organs it is true that all processes within our bodies are initiated and controlled by events occasioned by the environment. The complexity of this relationship is more readily grasped in connection with the lower than in the higher levels of ad-

justment; and the effects produced upon reflexes or automatic movements are more easily observed than are the results produced upon the emotional or thought processes. In the simpler types of response a neurologic nomenclature is sufficient, but when describing the different phenomena co-ordinated and harmonized in a mental reaction the use of descriptive terms based upon a wider biologic conception has the advantage of placing us in a more favorable position to analyze the nature of the highly organized synthetic processes.

Many of the methods that have been used in studying the synthetic reactions of human beings, especially those taking place in the higher planes, are comparable to efforts made to understand the movements of body or limbs by observing only the action of the flexors or extensors independently without consideration of their reciprocal relationship. It is this reciprocal relationship that is one of the chief factors in the movement of the limb; and by analogy we should study all responses in every plane with a view to the interpretation of the reciprocal relationships in the complex series of adjustments that we call life. We rarely think of the organization and intricate reciprocation of activities concerned in the emotional responses, such as fear and rage. The visceral neural mechanisms play a large part and we see that the network of nerves is adapted to produce a diffuse rather than a narrowly directed effort. Once again a thorough study of the various factors entering into a simple emotion impresses us with the elaboration of the synthesis and with the difficulties of determining the parts of the syntheses that have the greatest bearing in giving specific values to one or another link in the chain.

A study of the nervous system for the purpose of ascertaining whether there are structural conditions that facilitate the grouping of functions makes apparent certain facts. In the higher animals physiologists have demonstrated the importance of the cerebral cortex and basal ganglia for the completion of the syntheses. The decorti-

cated dog and decerebrated cat still have the power to express anger, but they lack the parts of the mechanisms that elicit response upon the incidence of anger-producing stimuli. The layers of the cerebral cortex are probably of value in both focussing and synthesizing activities; but the chief function of this higher centre seems to lie in associating and creating various mental activities that form harmonious systems.

Within recent years the word *integration* has been generally accepted as designating what is thought to be one of the chief functions of the nervous system. There is, however, still some confusion in regard to the significance of the term and few persons agree as to the exact nature of the processes that produce an *integration*. Sometimes the process of integration suggests summation, like the stringing together of beads on a thread. This conception is too crude to convey a just idea of the actual complexity of the process. Physiologists are in a measure responsible for this formulation, since it has been the custom of one school to place overmuch emphasis upon the importance of the central nervous system and to accentuate the hypothetic value of organs for the reception and transmission of impulses.\*

In one of the simplest forms of integration, usually accepted as typical, a sensory process is started in an end organ by an incident stimulus and the disturbance in the neural elements is conducted toward some centre from which it is transferred to a muscle. With this mechanism as a basis a conception of the nervous system is often built up that represents a kind of apparatus adapted merely to the transference of incident stimuli to the various parts of the body. It is perhaps this conception that gives the hypothetic basis for an association-psychology. It assigns to external objects an independent reality, materialistically or idealistically conceived, so that each object has its representation in consciousness as soon as the latent idea, impelled by the incident stimulus, is projected from the

\* Radl, E., *Neue Lehre von zentralen Nervensystem* (Engelmann, Leipzig, 1912).

subconscious to the conscious field of adjustment. This is illustrated by vision. The stimulus impinging upon the retina, together with the attendant chemical or physical changes and the subsequent cerebral processes, are all taken for granted by the association-psychologists, while the entire perceptive process is arbitrarily divided into hypothetical links which are so sharply contrasted with each other that they do not suggest the integral unity of general biologic processes as they occur in living beings. Such ideas as to the nature of the integrating processes are unhappily more easily represented by symbols indicating fixed states than are any of the variations existing during life.

Language is naturally adapted to describe the definite, fixed states of inanimate objects, and is therefore handicapped when called upon to express the processes involved in the life of animate beings. But life cannot be represented by fixed formulæ, since the vital phenomena represent a series of constantly varying relationships. Few of us note the steadily unremitting character of the life process, or the uninterrupted changes represented by the storing up and discharge of energy necessary for the establishment and maintenance of individual adjustment. If during sleep and unconscious states the higher intellectual activities appear upon superficial examination to be temporarily inhibited, we should not forget that the underlying mechanisms (reflex, automatic) are operating continuously; and during the apparent cessation of conscious activities the foundations for new adjustments are being laid and the continuance of older adjustments are perfected. Bearing this continuity in mind we realize the aptness of Paulhan's remark, "Our spirit (*l'esprit*) never ceases to act," since it is continually forming new combinations or syntheses expressed in ideas, hopes, fears, etc.\* We must rid ourselves of neurologic terms that possess a very limited applicability and substitute as far as possible those that suggest the broader biologic relations.

\* Paulhan, F., *L'activité mentale et les éléments de l'esprit* (Alcan Lib., Paris, 1913).

Once mental phenomena are regarded as part of an organic synthesis, there is less danger of "mind" being considered apart from its setting. We then see that instincts or other forms of mental adjustments are important factors in human activity; and the special form of organization by which the conative force of an instinct, for example, is linked with emotional prompting and volitional control is recognized as depending upon a deeply laid synthesis, marked by co-ordination of the functions not of one but of many organs.

Hitherto we have been kept too much in ignorance about the foundations upon which the conscious processes rest, and have dwelt much upon their hypothetic value. If we are to understand the nature of the synthesis expressed in the vital activities, we must learn to appraise correctly the relative values of the different links. Consciousness, it has been said, corresponds figuratively to a mountain peak that rises above a sea of mist, while the totality of the vital forces, represented by the great mass of the mountain, remains hidden from view. So the relations of the parts can only be understood by the knowledge of the vast structure underlying the small but visible parts.\*

The philosopher, in discussing the mental faculties, particularly the process of ratiocination, has been equally at fault in treating the phenomena as without connection with the activities occurring in the lower planes. Kant, for instance, tried to isolate reason and to discuss the problems concerning the genesis of this faculty as if it had practically no relation to the more fundamental reactions involved in sensitivity, to the development of the trends of activity, to the birth of desires and the lower forms of volitional activity. He went so far as to express the hope that some day human beings might exist from whom the emotions had been sublimated and who would be dominated by pure intellect. The science of ethics has also been treated too often as if it had only remotely to do with any theory of human conduct based upon human experience. But when

\* Miller, R. S., *Contributions to the Psychopathology of Every-Day Life*.

we approach the study of reason by the evolutionary method and pass from the analysis of lower to higher faculties we gain some insight as to the complex synthesis of processes taking place in connection with these higher forms of individual adjustment.

The extent to which the various mechanisms occurring in the higher levels of adjustment are governed by definite biologic laws is a question still unsatisfactorily answered. Although we cannot trace in detail the mechanisms of association connecting these events of one person's life with his appreciation of good music, or with the mention of Vesuvius and its associated memories of volcanic eruption, or its crater capped with "Pliny's pine tree," no intelligent person will deny the probability of some biologic force determining the phenomena and indicative of the existence of mental organizations that are dependent upon laws as definite as those that control the movements of lava thrown from the crater or sound waves from the instrument.

The roots of what at first seem to be isolated mental complexes may sometimes by thorough analysis be traced very often far down to a simpler instinctive reaction, so that we are able to follow the genesis of a synthesis after resolving it into more elementary parts. It is worth noting in this connection that the pitch to which motor mechanisms are set determines to a greater degree than is commonly supposed both the character of our perceptions and the drift of our ideas and thought processes.

In discussing the problem of association of ideas Dunlop\* has suggested a biological line of approach in the attempt to explain the phenomena included in the act of perception. The image as a copy of reproduction of sensation of variable mode does not exist. The present content is to a large extent the product of a complex of muscle sensations. The images in the associative process should no longer be considered as merely the pale ghosts of former sensations. The unit of psychological activity

\* Dunlop, K., "Biological Basis of the Association of Ideas and the Development of Perception," *Psycho. Biology*, 1920, II, p. 29.

is a reaction in an arc starting from the sensory neuron and ending in the terminal receptor. The response produces modification of activity in the effectors, which are either striped or smooth muscle, or glands. There is no consciousness without a complete reaction, although there are certain reactions which do not produce consciousness. If we consider the starting-place and termination of the reaction, it is obvious the arcs connect structures which may be either similar or dissimilar; the former are homeodetic and the latter heterodetic. The heterodetic arcs terminate in one of three classes of effectors, whereas the homeodetic probably only include one kind of tissue, namely, muscle. The heterodetic arcs condition perception, whereas the homeodetic condition thought. The later group of reactions once established may become habit and condition associative trains of thought. This suggested line of explanation has the great advantage of bringing the whole problem of association of ideas into close relation with the other biological processes going on in the body.

We have already pointed out in a preceding chapter that every living organism is in a state of primary indifference until the balance of forces or energy is disturbed, whereupon a condition of irritation or irritability intervenes. This change we have seen causes a disturbance in the entire energetic situation, and imprints or modifications are produced in the living substance; conditions defined by Jennings as the changed physiologic state. The sum of hereditary and acquired imprints stamped upon any organism represents its store of imprints; the phenomena connected with these imprints are mnemonic phenomena, while the mnemonic potentiality of any organism is the mneme. A series of imprints or a number of complex organized reactions may be partly reproduced by a repetition of those conditions approximating those responsible for the original disturbance; but an exact reproduction of all the conditions primarily responsible for a given state of sensitivity never occurs.

The lines along which organization develops may oc-



asionally be traced by observing the character of the original imprint action or primary stimulus. The secondary or "outcome-reaction" is also referred to as "outcome-stimulus." We have noted in an earlier chapter that these phenomena are well illustrated by the dog, which as a result of stored-up impressions, drops his tail between his legs and runs off whenever a boy stoops to pick up a stone. Only a partial stimulus is needed to recall to the animal an elaborate synthesis of visual memories, pain stimuli, and the recollection of experiences as to the best way of escape from injury. This exemplifies the character of the organization prevailing in response to that type of reaction described by Baldwin\* as circular; associated with the imprint or changed psychologic state a set of responses follows that are favorable to the individual.

A more complete study of the mechanisms concerned in the act of binding together of stimulus and response will alone enable us to understand the nature of the organization of all activities. We must, for example, find out more about the reasons for the permanence of certain systems and the comparative instability of others; although this will doubtless require a much more detailed analysis of motor habits than is now at our disposal.

The welding forces of the organism appearing in connection with the higher processes depend upon the functions resident in the cerebral cortex, which in their turn are based upon the more general and less localized biologic reactions. In addition to the processes of imprinting, registering, and subsequent elaboration there are the functions related to the mechanism of recall. All stimuli simultaneously incident bring about within the organism a corresponding state of irritability, and they stamp and leave behind them as residual products imprints or series of imprints. The partial recall of the special energetic conditions, which have engraphic action, often tend to reproduce imprints occurring simultaneously. The bonds uniting the various

\* Baldwin, J. H., *Mental Development in the Child and Race* (The Macmillan Co., 1897).

imprints are described as the links in the process of association, but so little is really known about them that it is impossible to do more than indicate their existence.

The appearance, continuance, and disappearance of the original state of irritability is dependent upon the incidence, continuation, or cessation of the primary energetic conditions collectively designated as stimulus. The harmonious vibration of the original mnemonic irritability is known as homophony. Although the word homophony refers only to the phenomena of sound, it has been suggested that its use be extended to include such reactions as may also occur in connection with smell and other forms of sense-perception. In the familiar reactions of animals we note many illustrations of homophony and the congruous or incongruous character of subsequent reactions. Sounds to which they are accustomed, like the call of a mate, give rise to one set of responses, while if the note be not true, the slightest discord explodes a chain of reactions which result in precipitous flight or in preparations to meet an attack.

Discord, too, may, as we shall see later, precipitate a conflict in human beings. The violent emotional reactions brought about in the musician by a single discordant note, or in the artist by inharmonious colors, are familiar examples of such reactions. For the incidence of homophony it is unnecessary for the original stimulus to fall within the field of consciousness; and the mechanisms producing congruences in the lower levels are of equal importance to those producing homophony. In some of the processes of recollection the various links in the chain are unequally emphasized, occasioning a process of abstraction such as happens when visual memories are weakened or blurred with the result of a partial synthesis comparable to a composite photograph. But ordinarily as a consequence of the repetition of a stimulus a new imprint is formed which tends to vibrate harmoniously with the first. When a state of irritability is repeated, the existing engram is not only strengthened but arouses a new engram vibrating harmoniously with it.

At present we can do little more than indicate the more or less superficial causal relationships between the different links in the chain of comparatively simple responses. In a general way it may be stated that mechanisms or motor attitudes give rise to impulses; and that these in turn form nuclei from which may be traced from very simple beginnings the development of a broader synthesis to the moment when an act is about to be performed that necessitates a choice and culminates in a full-fledged volitional process. The thread, however, uniting various mechanisms and focussing them upon an object to be attained, is an organic need which usually represents a very complex integration of physiologic processes. The conscious activities—the higher syntheses—are made up of many so-called elementary processes linked together by a chain that is sometimes obvious; but since most of these links are in subconscious levels the chain is more often indistinguishable. From this we see that every form of adjustment occurs either directly in response to an external stimulus, or by the actualization of some latent disposition or tendency aroused by latent stimuli.\*

Although the process of psychological association as usually interpreted is quite inadequate as a basis from which to attack the problems of mental organization, certain lines of study suggested in connection with the conscious adjustments may be followed with profit. In attempting an analysis from a psychologic basis of any special form of association-mechanism, Ach has suggested the desirability of distinguishing between (1) the consciousness of an end or goal as subjectively experienced, (2) the result of choice indicated by the character of the expressed representations, objectively determined, and (3) the dominating trends that are both indicative and explanatory of the choice indicated by the succession of some definite end to be attained. According to Ach the line of direction in a given train of thought is probably never completely determined by a free representation or idea springing up independently,

\* Jaspers, K., *Allgemeine Psychopathologie* (Springer, Berlin, 1913).

but by an underlying state of excitation caused by very different factors. The links in the process may be more or less common to every man; that is to say, the actual process may be determined by its similarity to others, by subjective association, or it may be acquired by actual experience. We know, for example, that the representation of one color in consciousness ordinarily calls up the idea of other colors—an association determined by similarity based upon experience. It is necessary to remind ourselves, however, that the psychologist is only beginning to get an inkling of the undercurrents in individual lives giving direction first to one and then to another link in the entire process of association, intensifying one and repressing another. Sometimes pathologic conditions serve to bring out the intimate dependence of the different planes. Thus, during the period of convalescence from an acute disease unpleasant news may profoundly depress the patient and give rise to great restlessness, mental agitation, elevation of temperature, and other symptoms which would not appear were the patient in a normal state of health.

In the study of "mental associations" two parts of the process must be carefully distinguished; one that may be called the association-mechanism proper, and the other the relation of the process to the general biologic activities. But we should not make the mistake of always referring one link in the chain to the one immediately preceding it, since the factors really determining the appearance of one element in consciousness and the rejection of others very often lie far below the level of the conscious activities. The recognition of this principle is necessary to obtain a correct understanding of the fundamental mechanisms, and many cases remind us that it is well to avoid dogmatism in attempting to explain the sequence in the higher intellectual processes; and this precaution was not observed by the defenders of the association-psychology.

Harmony and congruity of relatively simple reactions in the lower grades are illustrated by speech reactions of idiots and parrots. In the birds some sort of connection

between words and the perception of objects is established so that when the object is seen the word is pronounced; although there is an absence of any real sense of relationship between the representation of the idea or word and the vocal expression. This primitive form of association may be observed in the average human adult when a word used to designate a given object is tied to it by an activity that welds or synthesizes the process in consciousness so that the name and object, together representing the unit, appear automatically. This synthesis is altogether different from the hypothetical mechanisms of the association-psychology.\*

The elements in the activity relationships, as Jaspers has pointed out, lie at different and not the same levels. The links uniting those in the same plane represent the association mechanisms, while those connecting the different levels indicate the relations to expressed activity. In the case of the association mechanisms one follows another more or less mechanically, and, as we should suspect because they are in the same plane, they are very closely related. These associations occur unconsciously, and the lower the plane the further are they removed from the focus of attention. In contrast the activity relationships are sensed as unifications; and the higher the level at which they occur the more understandable do the connections become.

The time consumed in the reactions should be noted; also the correctness or falsity of the association-recall, and finally the character of the processes in different persons, combined with careful observation of the factors that give the special stamp of individuality to the responses. We should also note the extent of reverberation in each reaction, the richness or poverty of the image recalled, and the accompanying evidence of emotional disturbance.

Frequently we remark interference with or inhibition of the normal reactions in forming the usual combinations, followed by the formation of forced unnatural associations, which experience has shown not to have any common

\* Jaspers, K., *opus cit.*

bonds. Sometimes a symptom known to alienists as perseveration may develop; that is, a tendency of the older impressions to block the process and interfere with the introduction of new elements. Indications of this occur when a person is fatigued, and the same words or ideas to the exclusion of others are likely to be repeated again and again. Here the mention of animals immediately suggests a single type—dog or cat—any form of excitation tending to call forth the same response. In cases of disease this tendency is greatly magnified, so that all questions addressed to the patient may be answered with a single word.

The synthesizing capacity may also be seriously interfered with by the absence of any definite end toward which the activity is directed. In such an instance sensory impressions, which under normal conditions are negligible, exert a dominating effect in directing thought and action. The flood of new impressions may become so rapid that the person affected sees parts of objects but has no time to synthesize sensations. In all such cases not only the mental symptoms but the motor set and general motor disposition of the patients to various stimuli merit attention. It would be decidedly unwise to restrict the examination of these conditions to an analysis of the so-called association processes; and the principle that holds good for abnormal states is equally applicable to the resolution of normal conditions. Important reciprocal relations between the different systems is clearly brought out in the connections between affective and perceptive processes. It is known, for instance, that in manic states with persistent euphoria—an exaggerated sense of well-being—there is an acceleration of the more superficial mental processes concerned in perception and an association of ideas based upon relatively superficial connections.

Adaptations in the higher planes of activity may be and often are sensed by us as intermittent (sleep or hypnotic states), whereas many of those in the reflex level continue uninterruptedly. In health, static energy is being stored up for subsequent discharge at higher levels and for con-

version into dynamic forms. The fluctuations in the range of adjustment are comparable to the rise and fall of fluid in a tube. The mere presence of the liquid at a certain level does not imply the introduction of any new factor; and this is also true for the adaptations. Nor does the extension in the range of adaptability imply that any specific change in the basic character of mechanism has taken place.

The extension of the range and the continuity in health of all these processes is evidence of a marked degree of harmony and indicative of the remarkable organization of activities with a purpose, namely, the satisfaction of some need. For example, a man experiences a sense of hunger and walks automatically down the street to a baker's shop, which he enters for the purpose of buying a bun. An organic need here shapes the direction of his activities in both automatic and volitional levels. In health under similar conditions a certain unity of purpose is preserved until the end is accomplished. On the other hand, in disease the mere lack of co-ordination in these processes may lead to starvation by reason of the existence of a dissociation between the desire for food and the mechanisms essential to procure and eat it. In the organization the first impulses in any direction are usually weak, but may rapidly gain strength until about a central nucleus are gathered minor systems so united as to form others of greater complexity. The comparatively simple organization apparent in the adjustment tending toward the immediate satisfaction of the ordinary bodily needs (hunger, thirst, etc.) is noteworthy in comparison with such complex mental states as envy and ambition.

The rapidity with which complex organization clusters about relatively simple processes is extraordinary. How often does the recollection of single events bring back to memory with lightning speed a whole group of complex memories! I have no recollection of a visit in early childhood to a certain city until the sight of an enclosed elevator on the river bank suddenly brings vividly to mind the

hotel where I stayed at that time and on the opposite side an elevator which for some reason now unknown attracted my childish attention and detained me long at the window overlooking the river. How marvellous is this sudden reverberation of long-silent memories that are unexpectedly projected into the field of consciousness! At present we may only speculate as to the nature of the primary mechanisms determining their reproduction. Are these imprints built up out of elements spelled, as it were, letter by letter until the complex is completed; or is the process analogous to reproduction by linotyping? So also the recollection one has of a day spent in mountain climbing represents a complex synthesis made up of muscular, tactile, visual, auditory impressions and the sense of effort and pleasure with recollections of companions of the trip—all of which may have been hours in forming and becoming amalgamated so that subsequently the general impression of an entire day may be recalled in a short time.

The new era in which physiology became a prominent factor also had many beneficial effects, such, for example, as prompting the psychologist to recognize the importance of analyzing what William James called the "physiological mechanics" of the emotions as well as of the intellect. The synthetic capacity of the organism is demonstrable at all levels and if there appears to be a break in the continuity of the long line of activities we may attribute it to inadequate knowledge and inability to trace the various links in the chain of processes.

There are some investigators who still fail to recognize the value of this principle in the analysis of the functions of the organism, being under the influence of the older static concepts; and consequently from them we hear of "psychogenic origins," as if these were quite distinct and unrelated to all others.

The term psychogenic ordinarily suggests a conception of function occurring at the highest levels, marked off by specific differences from adaptations in lower levels. Used in this sense the word stresses superficial contrasts so that



we are likely to forget the close relationship between the lower and higher levels of activity. Indeed, because of the very intimacy of these bonds experience useful for interpreting the phenomena of conscious processes will be derived from an analysis of a few of the mechanisms controlling the discharge of neural energy. Kempf, in applying this basic principle, which enters into all the integrations in which the nervous system is the controlling factor, has pointed out the value of the physiologists' work in explaining many of the fundamental processes of our mental life. A broad biologic view does not stress hypothetical divisions between psychic functions and physiologic reactions.

Remarkable accommodations are reached by the switching of energy first into one and then into another level. One man as he crosses the crowded street remains cool and collected while energy is being discharged at the voluntary level; his muscles respond promptly to conscious and voluntary control, which enables him to dodge the passing vehicles and to avoid collision with other pedestrians. Another person is confused and rattled by the numerous demands for prompt decisions. The flow of energy at the voluntary level becomes increasingly difficult and when part of the stream is diverted to stimulate the voluntary nervous system emotional reactions of great intensity ensue and are attended by mental confusion and increased inability to make a decision. Every example of well-considered action illumines nature's success in perfecting harmonious adjustments to such an extent that the very perfection of the mechanism hides from us the scope and complexity of the synthesis.

The perfected unity of even the simple voluntary responses may be more easily appreciated if we dwell for a moment upon the intricacy of the mechanisms involved, including on the physiological side the apparatus connected with the regulation of the blood supply, respiration, secretions of the internal organs, etc. These reactions are under the control of "centres" in the brain which are in turn in intimate connection with other parts of the nervous

system. The impulses finally ending in some kind of action are discharged along nerve paths appropriated at the time the overflow restrains the action of muscles which under ordinary circumstances would naturally be called into play.

The continual struggle to maintain the balance of the organism requires that energy be stored up and discharged first in one and then in another direction. This movement is marked by a constant readjustment of the vital forces which are as delicately responsive to the demands made upon the organism as is the mercury in the thermometer to the sun's rays. The ebb and flow of these forces represent to some extent opposition, and the balance is maintained by reflex, automatic, and voluntary adaptations. Mere assumption of the existence of these adaptations is not sufficient; we must endeavor to recognize the principles upon which the apparatus works, since the essential point in the problem is not the state or condition of the machine at a given moment but the comprehension of the processes concerned in the transformation of energy constantly taking place. A discharge in one direction cannot be regarded as a complete liberation of so much force, since opposing tendencies are active although to a less degree. This point has already been illustrated by reference to the first slow movements of the embryo which generally occurs in groups and all in the same direction. When a swing to one side occurs the restoration of the equilibrium is gradually effected and the swings of the body are repeated toward the opposite side. In the adult, when the mechanism of adjustment is operating normally, the movement is effectively controlled by the opposing group of muscles, and therefore the swings take place first in one and then in the opposite direction. The elaborate reaction is determined by the presence of receptors, conductors, and effectors; but, although for the convenience of description we divide the processes in relation to the anatomical constituents forming the arc, the response is a biologic unit.

There are two ways of tracing the expansion of these so-called functional units to secure a wider range of adap-

tability: one by following the improvements appearing during the ascent from the lower to the higher animals and the other by familiarizing ourselves with conditions in the life of a human being during the entire period of development.

In both ontogeny and phylogeny the higher syntheses are determined by those taking place in the lower levels. We see this principle illustrated when the more complete organization of the higher intellectual adaptation is consequent upon the increased co-ordination of motor activities. We have many practical demonstrations of this law; for example, children deficient in motor adjustment, if trained by manual exercise to co-ordinate the simple muscular activities, develop more fully their faculties in the higher planes; the background of conscious adaptations are the various motor responses.

Comparatively simple influences may limit or extend the synthesis and stamp it with certain characteristics. Apart from the conditions usually termed physiologic there are a few of a more local nature that deserve attention. Since the days of Johannes Mueller it has been known that stimulation of the sensory paths with various kinds of stimuli would give rise to the special form of sensation for which the tract was specifically determined; thus an electric stimulation of the optic nerve causes visual images to appear, whereas a similar stimulation to the auditory tract is followed by hearing sounds. There is also a certain relative degree of specificity of quite a different kind established in connection with forms of adjustment in the high levels which is more noticeable in people during the latter period of life or in some forms of alienation when the processes become stereotyped. We often notice with elderly persons that any kind of mental stimulation seems to produce a restricted series of images and perceptions, such as we have in perseveration, that constantly crop up in consciousness with no relation to the incident stimulus. A simple word may recall a host of memories associated with early life—in fact, any form of stimulation seems to arouse a similar series of recollections.

The element of co-ordination is also an important factor in the organization of activities. In every act, whether intelligent or automatic, there is a marked degree of co-ordination perhaps more or less conscious, and a bringing together of the various factors essential for adaptation. The sensory apparatus, as well as the various organs of the body, plays an important rôle in determining this co-ordination. In the trend of mental activities the excessive dominance of one organ may restrict or throw out of gear the entire organism; thus a rapid and excessive heart action may be followed by an attack of insomnia with an entire change in the outlook upon life—an outlook differing absolutely from the same person's state of mind in health. Constant irritation of certain parts of the process of adjustment may also have the effect of temporarily restricting the synthetic processes. In states of fatigue we frequently experience the annoyance of the constant repetition in our minds of one or two ideas and are troubled by our inability to get them out of the focus of attention.

If a person's activities are developed along lines which tend to accentuate conflicting trends or unnecessary repressions and which delay or completely inhibit the building up of many synthetic processes, disaster is nearly sure to follow. On the other hand, an excellent example of what a slight change in the direction of activities may do to effect harmony is the case of a feeble-minded girl who when she first came under observation required constant watching. Her life seemed altogether dominated by criminal instincts, so that she could not be trusted out of sight of a nurse. When, however, she was instructed in lace-making a wonderful change occurred and she became one of the most trusted and energetic workers. All the conflicts, cross-purposes, repression that continually checked and rendered difficult the organization of constructive forces in character either disappeared or took their proper place so that harmonious adjustment was possible.

Habit undoubtedly plays a most important part in the co-ordination of mechanisms. A specific perception has

been described as an expression of a sense-centre's habit of reaction, which thus brings together groups of perceptions that in time become characteristic of the centre's activity. All our customary forms of adjustments are probably gradually developed out of these acquired habits. Events within the field of conscious adjustments may be associated with, or form parts of, other processes or systems. A sensation, thought, emotion often establishes associations, although the connecting links in the chain may not be immediately apparent. Human activities are characterized by the tendency to form groups or systemized adjustments, and the soul has been described as the "systemization of the acts of the body."

The vital activity of the organism may to some degree be measured by the harmony and systemization expressed in the mental processes. The vigor expressed by the all-round personality is quickly recognized. This alertness is scarcely conceivable if it is assumed that the contents of the mind are arranged like the labelled specimens in a museum, where each object is separate and different; but they have a close analogy to chemical compounds, with their formation of new qualities and different reactions. From the actual combinations of carbon and hydrogen and their derivatives organic chemistry is developed; and in a somewhat analogous way out of the simpler responses of the organism an entirely new set of derivative reactions spring and form an extraordinarily large number of responses.

The remarkable manner in which organic sensations are so synthesized as to produce a feeling of well-being sensed as a unit by the normal person is illustrated by the condition known as euphoria. The emotional balance or tone essential for euphoria represents a series of very complex reactions, which under normal conditions measures subjectively the degree of the person's adaptation to the environment. Three groups of factors contribute, according to Dearborn, to it.\* First: there are the various factors de-

\* Dearborn, G. V. N., "Certain Factors in the Physiology of Euphoria," *Psych. Rev.*, 1914, XXI, p. 166.

pending upon nutritional and other influences emanating from the intestinal villi. Second: the complex physiologic conditions usually denominated as kinesthetic sensations proper; and, finally, a number of sensations of epicritic or dermal origin. The normal physiologic euphoria is determined by impulses originating in the kinesthetic or dermal receptors, and these are induced or favored by the body temperature and other factors, such as the state of nutrition. These mechanisms are so wonderfully blended in conditions of health that the definite exhilarating sense of well-being cannot be resolved by psychologic analysis into its many constituents.

The feeling of pleasurable satisfaction sometimes exhibited in connection with emotional states of elation may be associated with reactions revealing certain marked contrasts. There may be a sense of satisfaction so strong and impelling that there is a tendency to repress all other mental reactions within the field of consciousness. This is in striking contrast to that other form of reaction in which there seems to be a distinct inclination not to repress or inhibit, but to retain other activities and to color them with the same emotional tinge. The first condition is free of any sense of physical effort, whereas the second is accompanied by a definite feeling of capacity to meet a critical situation successfully. With this there is associated a corresponding rise in the sensing of the personality with an accentuation of the "ego."\* Closer analysis of these sensations will probably discover additional clues as to the bodily states conditioning them.

Whereas in health harmony prevails between all parts of the system and is sensed by the individual, in diseases conflicts may arise that often have an important bearing both by interference with that part of the reaction called sensory and with those reactions described as thought and voluntary activity. Moreover, each impression stamped upon the organism modifies in some way its activities. The

\* Mayer, W., "Zur Phenomenologie abnorm. Glücksgefühle," *Ztschr. f. Pathopsychol.*, 1914, II, p. 588.

inclination is strong to believe only those impressions that are represented in consciousness are significant in directing our activities. But the pranks played by memory should suffice to convince us that we can never know when impressions, even those long forgotten, may crop up to become important directing agencies along the higher planes of activity. We remember, too, how one idea often comes to mind to disappear as rapidly, while another, rich in collateral mechanisms, is temporarily fixed.

If an idea remains longer than an instant, it is supposed to carry with it a conception of abstractness. About this nucleus a new system, or systems, gathers with the possibility of the process of integration culminating in a "judgment." In all the higher complexes this is an important form of mechanism. According to Janet, "Human thought includes several elements: first, the materials, if one may so name them, sensations, juxtaposed images, and then the intelligent application of their arrangement, and an idea of relationship between them."

It may be well to refer just here to an hypothesis based largely on the elemental and not organismal conception which has been offered in explanation of the various mechanisms concerned in abstraction.\* Consciousness is assumed to correspond with just that phase of the physiologic process induced whenever there is a disturbance in the metabolism with the subsequent release of energy accumulated in the nerve cells. This theory presupposes that the intensity of the conscious process is dependent upon the mass of the bodies of the nerve cells involved; those with the temporarily greater mass tending to keep certain ideas or sensations in the foreground of consciousness. The cell body, in contrast to its processes or fibres, has the capacity to sum up stimuli and also, under normal conditions, of answering stimuli with relatively weak reactions, whereas the nerves are supposed to obey the "all or nothing" law, responding to stimulation whether weak or strong with re-

\* Verworn, M., "Die Zellularphys. Grundlagen d. Abstraktionsprozesses," *Ztschr. f. allg. Physiol.*, 1912, IV, p. 277.

actions of a single quantitative type. Whenever the irritability of the nerve is decreased, as in narcosis, low temperature, or a state of fatigue, a change in the nerves and conditions of response corresponding with those occurring in the nerve-cell bodies takes place. In this mechanism there is supposed to be one essential factor—an impulse not sufficiently strong to bring about an actual discharge of energy from the nerve cell may inhibit other impulses. According to this fanciful theory these mechanisms determine whether the predominating elements in thought processes shall be rich or poor in sensory elements. But our own opinion is that differences between trains of abstract thought and those in which the sensory elements predominate should be regarded as questions merely of degree, which does not involve any specific changes.

The more a system becomes organized, the more does it tend to extend and to embrace others, forming a synthesis of all the elements; thus the dynamic power of a belief depends largely upon the association it has with all the many sentiments that have been stimulated and fortified by education. The character or organization of our activities determines the condition giving the direction to the mental life, since it makes us responsive to one set of impressions and indifferent to others, creating likes and dislikes, and rendering one decision easy and another difficult. Moreover, the strength of the personality is proportional to the degree of organization, while successful adjustment in life depends upon the individual's capacity to form harmonious mental syntheses.

The release of energy is always necessary for the perfection and consolidation of any organization. The energy manifested in every vital process is constantly seeking an outlet for discharge. In lower levels a transformation takes place which is represented in the metabolic processes. The objective signs attending the storing up and release of this energy are numerous and occur reflexly, automatically, and as the result of "choice." A light, for example, strikes the eye and a contraction of the pupil follows. In this reflex



readjustment there is only a fraction of a second between the impinging stimulus and its reaction. Contrast this sudden adaptation with the one occurring when, as one sits idly dreaming, a long series of recollections is successively presented to the mind. The comparative quiet in the environment and freedom from distracting influences may result in the spontaneous recall of these memories, but the reasons for the appearance of one set instead of another might be traced to the trends established by complex mechanisms.

No one questions the fact that each person possesses a specific habitual attitude involving a definite type of organization and called forth in responses to changes in the environment. Thus one person's retina may be so sensitive to light that dark glasses are assumed whenever the sun shines brightly, while another welcomes the brilliant sunshine. Or, a thunder-shower may drive one person into a dark closet, whereas another delights in watching the play of the lightning. There are also those who look at life from the dark side in contrast to the irresponsible optimists.

We are naturally eager to know what it is that determines these differing courses of action and what springs are set that release the energy to follow one or another channel during its discharge. In the case of pure reflex action we are given no premonitions as to the nature of the discharge, although we may suffer if the response does not follow properly upon the incident stimulus. In more complex adaptations the neuro-muscular attitude, which admonishes us in regard to the possibility of successfully meeting a thousand different situations, is a marvellous monitor, and just because it performs its service with so little ostentation and so well, the value of its functions is seldom correctly appraised.

Organization does not imply repression or loss of individuality. The greater the organization, the more extensive is the range of personal adaptability. Over and over again writers have called our attention to the fact that all forms

of human activity in the many levels in which it is expressed give rise to more or less permanent systems and distinctive types of organization. In the higher ranges of activity there is an extraordinary interlocking and reciprocation of these multiple systems that reach in the intellectual types an astonishing degree of perfection. These arrangements enlarge the possibilities of adaptation and in no way impose any of the restrictions that the idea of a system involved in the presence of some imperfect mechanism connotes. The organization is in every sense a vital one and there is no basis for the idea that "mind is not very much alive." \*

The greater the demands upon any person, the greater is the necessity for a complex and thoroughly practical form of organization of the activities. This point is well illustrated in the emotional life, in which the arousal of an instinctive impulse forthwith organizes a series of complicated responses about a common focus. All the driving forces tending to the elaboration and perfection of character must include receptive and executive phases; and upon this latter side there is often a degree of organization capable of expansion to a wonderful form of perfection whenever it is necessary to attain some definite end by means of a right type of behavior. If our final problem is to acquire knowledge that will serve to explain the synthesis represented by human character, it is imperative to study thoroughly the genesis of the various systems, to inquire into the nature of the coalescences formed, and to try to analyze the degree of dependence of primary, secondary, and other subsidiary systems. Only then can we gain insight as to how to meet the ever-widening demands of living through activities more perfectly organized than any now possessed by human beings.

But present ignorance of the exact nature of the processes concerned in the genesis of a complex synthesis does not prevent recognition of the importance of the preservation of the synthesis of activities as illustrated by the demands

\* Gibson, W. R. B., *Mind*, N. S., 1916, p. 25.

of daily living. The energy accumulated by a man must be discharged through a number of different channels to maintain a satisfactory adaptation to the environment. The blocking of certain channels means that the excess energy as it accumulates is diverted along a few paths and, like a stream that has risen above its banks, may carry along before it everything that opposes the flow of the current.

From this the importance is evident that the activities of the organism should be adequately expressed, both for the maintenance and perfection of the synthesis. Great care should be observed that this expression be not curtailed by a narrow routine. Each human being should have the opportunity not only to express his or her needs but also to indicate to what extent these needs have been satisfied. Much energy is dissipated or directed into wrong channels by lack of opportunity for frank expression of what the real needs are. Such is part of the price paid for the conventional influences of civilization; the actual needs of the living organism are neglected so that repression of a baneful kind is frequently formed. Much too often the decision as to these needs rests upon data furnished by the conscious processes only. But the unfortunate outcome of this method will be discussed later in connection with the nature of conflicts.

The influence of the various temporary attitudes upon the direction of desire is illumined in the history of the following case. A young man, twenty-five years of age, upon being questioned, furnished the accompanying information about his life, and in his replies gave evidence of the existence of mental conflict. An only child, he had suffered from injudicious handling; at times his whims and desires were acceded to without question, and on other occasions he was subjected to very severe discipline. He remembered being overwhelmed as a little child either by the excessive, unrestrained affection of his parents, or, after a period when he was unjustly punished, by fear or varying degrees of resentment toward them. Pressure was undoubtedly exerted from without, but the strain was increased by the

constant nagging of inner conflicts and the indefinitely subtle feeling that satisfactory adjustments had not been made. During the years just after puberty these emotional outbreaks became less frequent, but there were periods when he felt a keen desire to get off by himself and away even from intimate boy friends. Repugnance caused by repeated irritation and an impelling, although ill-defined, sense of inability to meet the ordinary demands of his life made him often unhappy. He noticed that gradually a certain feeling of estrangement from his parents had developed and, as he grew older, he tried to find some satisfactory reason to justify this mental attitude toward them. In defense he assumed, step by step, a position based upon his idea that he was not understood by his parents, and, although this position did not lack some justification, its intensity developed out of all proportion to its cause. Later he substituted for it a notion of superiority, which so took possession of his mind that he eventually believed it no longer possible for either parent to comprehend or sympathize with his ideals of a general plan of life. When questioned as to this attitude it was interesting to observe the aggressive and assumed self-confidence displayed as he tried to defend his position. Only occasionally and under considerable pressure would he make the slightest admission that he might be in error. In many ways he evinced superidealism that tended to run riot, and he never tired of expounding his own views as to the necessity of elevating other people's ideals of life. It was impossible to make him realize the strange inconsistency in his own life expressed in his willing dependence upon his parents for necessary expenses and his irrepressible desire to preach sermons upon the benefits of idealism. His line of defense seemed at first quite impervious, but gradually there was aroused some slight appreciation of the actual conditions under which he was trying to reorganize his life for the purpose of meeting a failure to adjust successfully his own activities. This case demonstrates the seriousness of the consequences when there is a defective harmony between feeling and action.

As soon as the break in the synthesis occurs an immediate attempt is made to readjust activities, but in a manner to court disaster.

Another interesting and not uncommon phase of disorders like this is the tendency to express, because of a sense of inadequacy, ideas in abstract terms having no personal application. For example, in this case the young man's conception of the social world was one filled with ill-arranged inequalities; and his individual proclivities tended to give him such a distorted view of the environment that he was abnormally impressed by every evidence of lack of harmony among social groups without admitting his own defeat. His limitations in the field of organized activity helped to direct his thoughts inward and accentuated the severity of the conflict. Struggles like this constitute the drama of life.

Again, there is this fact to be noted; it is impossible to judge, merely by such incidents as are presented through consciousness, of the mechanisms by which the general synthesis may be either maintained or interfered with. The subconscious is not simply the antithesis of the conscious, nor is it merely a latent or imperfect representation of the conscious.\* To understand the relationship and the relative value of the conscious and subconscious activities in the higher forms of organization it is necessary to recognize the dynamic force of the latter. Because the engrams stamped upon the organism do not happen to fall within the field of consciousness we must not believe them to possess less dynamic potentiality. On the contrary, they exist in dynamic forms even in the subconscious field and at times are capable of exerting great influence upon those streams of energy that are discharged at the conscious level. And these impressions may be the starting-point for processes sufficiently dynamic to become conscious by the acquisition of such an accentuation of energy that under certain provocations they may destroy the synthesis of the personality.

\* Régis, E., and Hesnard, A., *La psychoanalyse des névroses et des psychoses* (Librarie Félix Alcan, Paris, 1914).

The forces actually controlling the mechanisms determining the synthesis of our activities have been described as consisting of two different systems, of which the elements of only one, more numerous than the other, ever fall within the field of consciousness. This system includes the adaptive mechanisms determining the character of the higher conscious levels, giving the special trend to thought and shaping both character and temperament. The other system represents a broader zone and is a more or less neutral territory between the conscious and the subconscious; and this supplies the material for our dreams and reveries.

The mistake is often made of trying to judge the extent and value of the mental organization by analyzing only the conscious processes. This gives a very one-sided view. The organization of mind is too closely bound up with that of the body to make it possible to draw any sharp line between the two systems. Mind and body together form a biological unit. The same principle applies to the investigation of mental phenomena; they should not be discussed as if they were the product of different senses or faculties. It was not the philosopher in his study, but the physician in close contact with patients in the clinic, who demonstrated the defects of an academic psychology and the value of studying the restricted field of the conscious adjustments in relation to the unconscious. We should be careful, in using the words "conscious" and "unconscious," not to convey the idea that the two fields are separated by rigid barriers. Freud's use of the terms "unconscious," "fore-conscious," and "conscious" carries with it an implication of this kind. Consciousness is characterized by an emphasis thrown upon certain brain activities that seem to stand out in marked contrast to the less emphatic brain activities, but the former is not a system totally distinct from the latter.\* Marshall is quite right in affirming we have no reason for assuming the existence of rigid and pronounced distinctions existing between the unconscious, the so-called fore-conscious, and full consciousness. The doctrine af-

\* Marshall, Henry Rutgers, *N. Y. Med. Record*, Sept. 25, 1920, p. 505.

firming the existence of a censorship admitting certain processes to consciousness, and repressing others also tends to stimulate belief in the existence of separate and specific functions.

In the dream the organized control of the brain that regulates and harmonizes instincts, feelings, and thoughts is considerably reduced. This is probably due to some extent to the removal of the control of the more recently acquired parts of the new brain, the highly organized cerebral cortex. The incoherence and astonishing paradoxes presented in the dream point to the removal or rather reduction in the calling up, selecting, inhibiting, and connecting processes. We do not agree with Rignano\* that the absence of primary affectivity is the cause of the incoherence. Affectivity is present, but it is not controlled. There are two objections to the theory that dreams are the result of the loss of primary affectivity—one is that there does not seem to be any evidence on the physiological side that the nervous centres controlling the emotional reactions are less active, and the other is that if Rignano's theory, regarding the dream as merely a pure intellectual process due to cessation of emotional control, is accepted we practically return to the old faculty psychology.

Not only in dreams but during the periods of great mental activity the close connection between the unconscious and conscious adjustments is often brought out in a very emphatic manner. We are familiar with the ease with which new ideas and the memory of long-forgotten events or persons often shoot into the mind. Often a problem for which we have in vain long sought a solution is correctly answered by a sudden thought, the genesis of which we are unable to trace. Brilliant ideas and strokes of genius seem to be the product of an instant's cerebration. The mind of unusual power possesses this very striking illative capacity of drawing correct inferences without following the rules of logic. At times the dramatic suddenness with which a correct in-

\* Rignano, E., "A New Theory of Sleep and Dreams," *Mind*, July, 1920, N. S., no. 115, p. 277.

ference is drawn suggests an inspiration. If there were any barriers dividing the mental organization into different functions the process of illation would be much less frequent than it is.\* We have been in the habit of sectionalizing the mind to such a degree that it has become exceedingly difficult to recognize the existence of some of the most important mental functions.

Many factors tend either to facilitate or obstruct the passage of impressions from one field to another: education is one, social conditions another, and general environment still a third, all either assisting in perfecting communication between the fields, dominating them absolutely, or repressing the transference of energy from one to another level. In discussions as to the comparative value and relations between these fields some investigators claim that consciousness is a useful reflex, in reality a luxury of the active psychism, whereas others believe it to be an organ of perception, imperfect perhaps in its mechanism, but still capable of extending to a considerable degree the range of adaptation.

In the various combinations formed by the elements in the two fields, the energy may be either potential or kinetic. In each of these complexes a number of different constituents, like the sense element, the idea of movement, and the intellectual factor, form a synthesis. To what extent one particular group will enter into consciousness and disturb or accelerate the ordinary flow of the stream of thought and feeling is determined by many factors represented chiefly by the affective life. In an analysis of the composition of any general synthesis it is instructive to see how far we may infer the character of the finished products from a knowledge of the parts. This necessitates a certain amount of guesswork at present, but nevertheless if care is taken there are decided practical advantages in the results of close observations. For this purpose the various forms of mental imagery have been made the subject of investiga-

\* Knowlson, T. Sharper, *Originality, a Popular Study of the Creative Mind* (J. B. Lippincott Co., Philadelphia and London, 1918).



tion; their relationship to other activities has been traced and some information gathered as to how far they are carriers of information. Martin has made an interesting communication on this subject.\* He cites the case of a university student, a captain of the baseball nine, in whom the images recalled pertained almost exclusively to athletic interests, and showed how absorbing these images may become as they tend to group about them many of a similar nature and to shove aside other considerations. The pleasure-giving power of an image and its originating image may be readily traced; and it is also evident that the visual images afford a significant clue as to the attitude of the person in regard to the actual world with which direct contact is maintained. Besides the visual images we must take account of the kinesthetic, auditory, and tactile impressions and avoid overemphasis of a single kind of impression. Many points must be considered in studying these "images," which may be regarded as samples of the personality. Because the mechanisms conditioning them often lie so deep in the field of consciousness, to understand their genesis both the static and dynamic conditions prevailing in those lower levels must be estimated. Indeed, in any consideration of the synthesis of activities as represented in such phenomena as temperament, character, and intellect we must never forget for an instant the dynamic forces constantly at work, lest we make false deductions that suggest static conditions or quite independent processes.

In what has been said about the nature of the synthetic processes we have, in the main, only restated some of the principles familiar to many observers. We already possess excellent descriptions of some of the phenomena of consciousness, and the explanations offered of the mental mechanisms are in some respects less hypothetical than those implied by such terms as "suppression," "repression," or "sublimation." Sidis has called *moment-consciousness* the unit of a psychologic individuality represented by a syn-

\* Martin, L. J., "Personality as Revealed by the Content of Images," *Psychol. Bull.*, 1917, XLV, p. 44.

thesis. While we may not be able to explain everything occurring preparatory to the incident of a complete synthesis, we may yet form a general idea of what has happened. Around a nucleus there is grouped a series of experiences which at a given instant are focussed. Each moment consciousness changes as rapidly as the elements composing the synthesis shift. In the more elementary syntheses we have to do with relatively simple adjustments which lack the elaboration marked by reproduction, recognition, psychologic memory, and the idea of self. Beginning with these primitive types of "desultory moments" we find all grades of elaboration to the highest type of self-consciousness, and we pass with no break or barriers through stages marked by comparatively simple aggregation—in which the links of the chain are unobscured by the complexity of the synthesis—to the more complicated processes associated with the beginnings of perceptual life.

The phenomena of adjustment expressed in animal behavior do not rise above the level of the simpler compound synthetic moments until we reach the higher vertebrates. The mechanisms connected with the reproduction of the cognitive moment have been accurately described as presenting substantial additions to the synthetic processes, and, in the act of representation culminating in recognition, the range of adaptability is considerably extended. The simpler reactions are indissolubly connected with the more complicated ones, and in tending to form groups are also marked by harmony.

The relations of the different levels are reciprocal in character; were this not so there would be some reason for assuming consciousness to be a series of adjustments altogether independent of the control of subconscious activities. As a matter of fact, we are so accustomed to the very intimate blending of activities in the personality that it is only when some disturbance occurs that its usual harmony attracts notice. When the incidence of disease or the sweep of an emotional storm compels us to estimate the degree of dissociation in consciousness, we recognize for the

first time that even in a momentary content there is far more to be considered than what may be called the surface phenomena.

In any discussion of the organization of activities the question arises as to the possibility of definite types capable of ready recognition. Common experience answers that there are. We are quite accustomed to speak of special types of organization under the heads of temperament and character, but it is often very desirable to be able to assign a personality with distinctive traits to a given class. If no very rigid outlines to groups are drawn, the fact that a person has certain definite mental characteristics may often justify the inference that other unrevealed qualities are present that experience teaches are usually associated with a special type of organization. Such deductions used cautiously facilitate the study of character. John Stuart Mill referred to this subject as ethnology, and at present data are being collected which should lay the foundations of a science to be based not merely upon a differential and directive psychology but grounded upon the biologic viewpoint.

In estimating character we are really endeavoring to measure and describe the threshold, rate, and persistence of responsiveness to environmental stimuli. The special form of organization assumed by these responses gives "character" to the individual. This responsiveness to stimulation which is a basic factor naturally depends primarily upon the velocity with which nerve impulses are transmitted, usually about thirty metres per second. The slowness or speed with which a person reacts to incident stimuli is one of the chief phenomena to be considered in establishing a provisional classification of the personality. But the problem is constantly complicated by reason of a multitude of other factors, chiefly biologic, that modify the reactions. The velocity of the chemical explosion causing the nerve impulse may be either diminished or exaggerated; so that the rate of transmission is increased or retarded. In other cases the responses may be delayed or erratic which may

induce a special form of disorganization. The "hair trigger" type is one in which the general sensitivity for certain forms of stimuli is increased. Another common type has been designated as the "relay" type; possessing the capacity, notwithstanding the reduction to the minimum of the initial display of energy, it accumulates "relays" and in the end achieves noteworthy results.

Examination of some of the fundamental facts connected with the adaptation of the organism brings realization that the different types of responses must be dependent on the factors governing the conditions controlling the production and transmission of nerve impulses. The discussion of these basic problems has resulted in the suggestion that conclusions of investigation should be expressed in a general formula indicating character to be a directed, vector quantity,\* although this would only express one factor in the equation.

Any discussion of the highest degree of organization, such as is displayed in intelligence, must, of course, involve the consideration of very complex conditions; but here again a very slight change in the angle from which the topic is approached may be advantageous. As in other problems of the personality, our hope for a final analysis of these intricate mechanisms, collectively described as intelligence, must be based upon the character of our plan of attack. A lack of recognition of the foundations of these specialized reactions, carefully built up and no less carefully concealed, has been one of the prodigious mistakes of civilization. Indeed, no investigation should be restricted to the study of the conscious elements. Our former ways of thinking have done little to remove the obstacles in the way of an analysis that can be profitable. The riddle of the human intelligence and character has been treated as insolvable since the dawn of history; it has only recently become evident that in the study of man as a living organism do we find any key to its solution. We must search below

\* Richardson, H. J., "Character; Its Analysis and Measurement in C. G. S. Units," *J. Exper. Ped.*, 1915, III, p. 182.

the conscious processes in which interest has hitherto centred, since probably nine-tenths of the mechanisms giving the set and individual stamp to both intelligence and reason lie far below the conscious levels.

The secret of intelligence is not to be found in the field of consciousness alone; but reasons for "an intelligent act" must always be sought for, often in the subconscious as well as conscious processes. Thus to-day we no longer attempt to explain an idiot's thoughts by investigation of his mental reactions alone; we try to take into account his impoverished emotional life and his entire make-up, physical and mental. Only by applying the same method to the investigation of the highly intelligent person shall we arrive at a comprehension of his higher and lower functions. Warren very justly insists that it is the duty of science to study *all* the facts bearing upon the conditions necessary for intelligence and to refrain from an arbitrary selection of data to bolster up some pet theory or to supply the missing link in a chain of evidence corroborative of some hypothetical explanation of the human understanding.\*

The few data available as to the mechanisms taking part in intelligent acts have made them seem unrelated, so that it has been sometimes assumed that these special adaptations were not subject to the general laws of causation. But intelligence cannot be judged or discussed satisfactorily apart from acts; indeed, it can only be expressed by acts. We are familiar with only one phase of the intelligence of Shakespeare; much more would have been known about his mental qualities if there had been an opportunity to observe his life and his behavior. In judging the different types of intelligence summarized by Warren as (1) creative, exemplified in art, (2) inventive, (3) initiative, and (4) intelligent adjustments to new and critical situations, we are too much inclined to minimize the behavioristic elements in the complexes and to express our judgments in abstract terms. In forming an opinion as to the nature and value of

\* Warren, H. C., "The Mechanics of Intelligence," *Philosoph. Rev.*, 1917, XXVI, p. 602.

a thinker's intelligence expressed possibly in abstract terms we should not forget to give due weight to the various fundamental reactions necessary to the adjustment of his life.

The speculative philosopher has only been attracted to one phase of human intelligence, the smaller and less important aspect. We say smaller and less important advisedly, since it is really the sweep of the forces below, contracting or extending as the case may be, the field of consciousness, which determines the degree of intelligence with which a given situation is met. To make an effective use of available energy the biologic forces are in most instances marshalled and aligned with little aid from consciousness.

## CHAPTER VII

### CONTROLLING MECHANISMS

#### (INHIBITION)

IN the preceding chapters we have pointed out certain phases of the genesis and integration of activities, particularly as they occur in the higher levels of adjustment. Attention has been directed to the manner in which the simpler serve as a basis upon which the more complex adjustments are built up. It is obvious that besides cumulative or additive tendencies, there are others that are desistent or inhibitory. The harmonizing factors in the organization of the responses of organisms depend quite as much upon the influence of these latter as upon that of the former mechanisms.

We can get an excellent general idea of the variety of mechanisms concerned in the process of inhibition by recalling some of the facts connected with the phylogenetic development of the central nervous system. In the higher animals it is apparent that the distribution of energy depends not only upon the structure of the nervous system and its more or less specific functions, but also to a large extent on the character both of the external sensory organs and the effectors, as well as upon the reciprocal relations existing between higher and lower centres. In the higher vertebrates the structural and functional arrangements provide for the antagonistic action of pairs as well as groups of muscles. Provision for these functions does not exist in the simple netlike arrangement of the nervous system found in invertebrates.\* It is very important to remember that the discharges from the central nervous system giving rise to various forms of reaction are not only conditioned

\* Jordan, H., "Die Phylogenese der Leistungen des zentralen Nervensystems," *Biolog. Zentral. Bet.*, 1919, no. 10, Bd. 39.

by what takes place within the central nervous system but to a very large degree are affected by processes taking place in the muscles. The finely developed muscular sense which is one of the chief characteristics of vertebrate organization is also an exceedingly important factor in directing the discharge and determining the lines it follows. In the case of the spinal cord there are many tracts which may be followed by energy seeking for some expression in a response. These different tracts are supplied with switching facilities, and we should constantly bear in mind the fact that the peripheral conditions fully as much, if not more, than those in the central organ determine the lines of discharge. In the lower animals, possessing a diffuse network, these individual tracts are absent which in the more complicated organizations are opened or blocked; a reaction in which the well-developed muscular sense plays a very important part.

One reason for our lack of knowledge as to the nature of inhibition has been that relatively little effort has been made to analyze the mechanisms of adjustment that occur either during the time immediately after birth or in embryonic life when responses take place in those levels of activity which include the inhibitory processes as important factors. The study of the inhibitory mechanisms has been limited chiefly to the processes as they occur in adult life, when, on account of their complexity, there is less chance of recognizing the various links in the synthesis of the reaction. Our present knowledge inclines us to overemphasize the importance of the additive functions in the integrating process, and overlooks the fact that the transformation of the manifold into the comparatively simple, the essential part of the process of adaptation, is in as great a degree dependent upon the discriminating and selective functions as upon any other factors.

One or two points in regard to the machinery by which the more complicated adaptations are secured may very properly be mentioned before we enter upon the immediate subject of the chapter. We have seen how organisms during the course of phylogenetic development become more



complex and, as their receptive and reactive capacity has increased, mechanisms have developed which are necessary to protect the organism from harassment. We have noted how in the oldest portions of the vertebrate brain, or archepallium, there is an extensive apparatus devoted to the reception of stimuli and the immediate transformation of these into outgoing impulses. These exteroceptive and proprioceptive mechanisms insure very often the safety and protection of the animal, but do not permit of any wide selection in the means employed. In the scale ascending from fish to man we have seen that other mechanisms are developed and that even in reptiles a new brain, neopallium, is formed, which presents a corticosomatic system of control or organization with the purpose of insuring the animal against the necessity of plunging prematurely into activity in response to every stimulus and so offers some latitude in the choice of methods of defense. As a result of this arrangement, the action of certain functions of the nervous system are relegated to obscurity while others come more prominently into view. In this chapter, while due consideration will be given to the mechanisms employed in the arrangements for the distribution of energy, we shall chiefly discuss some of the elements concerned in the simple phenomena of inhibition, together with the selective adaptation exhibited in choice of which inhibition is a basis.

Sherrington\* has noted in connection with the various planes of activity the impetus to and control over the nervous system exerted by the external world of environment; "especially," he writes, "in the motor part and always in the interest of co-ordination." But he does not lose sight of the fact that, since there are no specific differences of function, too great emphasis should not be placed upon the apparent contrast between the external and internal influences. So also it would seem logical to reason that both external and internal influence should be counted upon to set free the inhibitory impulses that are equally part of

\* Sherrington, C. S., "Inhibitions as a Factor in the Coordination of Movements and Postures," *Quart. J. Exper. Phys.*, VI, p. 251.

volitional activities. Inhibition, however, has received less attention than those factors that incite to response.

In reviewing the opinions in regard to some of the characteristic features of these inhibitory mechanisms, it is evident that the angle from which the subject is approached has a very important bearing on the discussion. Some students try to analyze the simpler reactions by looking down upon them, as it were, from the level at which such complicated inhibitions as those expressed in volition take place. If this process were reversed and we could accustom ourselves to looking *up* to the latter, exploring first the foundations of the simpler ones, there would probably be greater progress in this line of research. In discussing the nature of the inhibitions in the higher levels, account must be taken of the close connections between such apparently widely separated phenomena as motor and conscious adaptations, that is to say, "between cognition and response."

For the purpose of informing ourselves somewhat of the nature of the mechanisms concerned in the inhibitions occurring in connection with the conscious adaptations, we may begin by noting very simple reactions; such, for example, as those connected with the antagonistic muscles. We find then that when a limb is flexed there is no complete and total relaxation of the opposing extensors, but the latter retain their normal tonus. Probably similar conditions hold true for processes connected with volitional responses. The reaction in the direction chosen does not imply that the antagonizing processes are altogether suspended. More complete knowledge of the process that enables a person to bend a limb will greatly aid in the solution of such psychologic phenomena as those involved in "evaluation" and "choice," processes taking place in all voluntary acts. To sweep away many of these perplexities now concerned in the study of consciousness, a clearer knowledge is imperative as to the relations between the simpler forms of excitation and inhibition.

Much advantage will also accrue from a study of the apparent oppositions between the actions of the sympathetic

and para-sympathetic or between the sympathetic and autonomic nervous systems. Both exert an enormous control over the anabolic and katabolic processes in exciting or restraining secretions which shape the emotional life, one of the dominant factors in determining the extent and time of voluntary action. It is a matter of daily experience that depressing or disagreeable emotions equally with elevating and pleasant ones have a profound effect upon the processes of secretion and digestion, and these in turn may modify the emotional responses. Thus a continual struggle seems to be in process between the forces tending to conserve and those operating to expend and dissipate energy.\* And in this interplay of forces the lower forms of adaptation are in no wise exempt.

In exploring the voluntary reactions in which we have seen the inhibitory processes are concerned, we cannot ignore the phenomena of conscious adaptations. An analysis of some of the simpler mechanisms will carry us back to the first principles of neuro-biology; and such a method of research would prevent our regarding superior forms of inhibitions as epiphenomena superimposed upon other activities merely to hold them in check. The conception of any activities as superimposed, although the basis of the opinions of a certain school as to the action of voluntary control, tends to place the act of inhibition in too sharp contrast with the related excitation, of which process it forms an integral part. Still other writers believe that consciousness is nothing more or less than the potential energy into which a portion of the kinetic energy of the acting stimulus is transformed when the pathway prepared to receive the stimulus is blocked or interfered with.† This view suggests others of more fundamental importance, and consequently it is hopeless to define involved situations until a decision is reached as to the simpler forms.

\* Brown, W. Langdon, "The Croonian Lecture on the Rôle of the Sympathetic Nervous System in Disease," *Lancet*, May 24, 1919, p. 873.

† Montague, W. P., *Consciousness a Form of Energy. Essays in Honor of William James*, N. Y., 1908.

For this purpose we may consider a few points in regard to the machinery by which the simpler inhibitory adaptations are brought about.\* There seems to be an important difference in the inhibitory mechanisms of the vertebrates and invertebrates, in the former the decision as to whether an impulse shall exert an exciting or restraining influence being determined by the different stations or centres within the central nervous system; whereas in invertebrates structures in muscle or skin may have a considerable degree of local control in the inhibition of activities.† It may be stated as a general principle that the more complex the organization of the nervous system, the greater is the tendency to relegate the control of its mechanism to the central station, the brain. This form of arrangement is in strong contrast to the conditions existing in the lower animals, in which the subsidiary centres for the control of responses are interpolated within the chief circuit, as, for instance, within the muscle. In the higher vertebrates the inhibitory control of impulses is the result of a central or deeply located mechanism which in invertebrates may be near the periphery, just below the skin.

In the early life of the vertebrate embryo conditions are peculiarly favorable for studying those primitive forms of response which upon casual observation seem to be altogether lacking in inhibitory processes. The first period in the rhythmic activity of the heart is not marked by the appearance of reactions specifically different from those taking place in simple masses of protoplasm. The rhythmization is doubtless more pronounced but not actually different from the phenomenon as it occurs in chemical reactions, and inhibition, if present at all, is of a similar primitive nature. The earliest rhythmic phenomena, the first move-

\* Weber's opinion, published in 1846, that certain nerves connected with the heart would when stimulated restrain or diminish its activity is historically interesting. Also, that Brown-Sequard first gave the name of inhibition to that part of a nervous phenomenon which interposes an element of interference, or prevents the development of the entire complex. (Brown-Sequard, *De l'inhibition et la dynamogène.*)

† Hoffman, P., "Ueber die doppelte Innervation d. Krebsmuskeln," *Ztschr. f. Biol.*, 1914, LXIII, p. 411.

ments of the heart and body, are probably due to a "balancing in the centres of more or less equal and opposite activities." \* During the period of growth when the large vagus nerve finally reaches the heart there are signs of an active interference with the rhythm, due to the discharge of inhibitory impulses, not in themselves specifically different, but giving rise to reactions that have superficially the appearance of being antagonistic.

The appearance of the vagal inhibition marks the introduction of a factor that suggests a definite specificity for actions concerned in voluntary control. Later, no matter how complex the process of adjustment may become, rising even to the highest level of voluntary choice, there is no other element introduced into the chain that has the appearance of standing out quite so sharply as a distinguishing characteristic.

The apparatus by which voluntary activities are executed, the autonomous musculature of the internal organs, receives two kinds of centrifugal nerves. This is in contrast to the skeletal muscles which are not supplied with inhibitory nerves and therefore reflect truly the condition of the motor centres. The existence of specific nerves for the conveyance of inhibitory influence affords ground for reasoning that we must reckon with an active process and not merely a negative state; but the presence of these neural tracts is no proof that inhibition and excitation are actually different processes. Nor does increased elaboration in structure necessarily imply complexity of function; nor should the fact of the neural supply of the muscle being from a double source, one set of fibres going to the muscles and the other to the sarco-plasm, be taken as evidence of an equally sharp division of function.

Many activities of the organism seem to stand in anti-thetic relationship nicely balanced one against the other, not unlike the physical conditions described as assimilation and dissimilation, alkalinity and acidity, and positive and negative poles of electrical phenomena. Although inhibi-

\* Graham-Brown, *Quart. J. Physiol.*, 1913, VI, no. 3.

tion may be described as not only accompanying but as actually forming the counterpoise to excitation, the study of the complicated volitional activities will be greatly facilitated by recognition of the fact that the two phenomena stand only in superficial antagonism to each other. This principle, a basic one, merits emphasis. Inhibition is an excitation interfering with other excitations. An excellent example of the manner in which one stimulus may interfere with a stronger one and block its action is indicated as follows. If a muscle is thrown into strong contraction by stimulating one nerve (*a*), its action may be inhibited by a stimulus to the nerve (*b*), which by itself is not sufficiently strong to cause a contraction of the muscle. In the earthworm, a relatively simple organism, it has been shown that there may be a reversal of reciprocal inhibitions of muscular activities when a normal inhibition is converted into an excitation. The contraction of its circular muscles is generally associated with the relaxation of the longitudinal fibres, but all may be thrown into a state of excitation by the administration of strychnine.\*

There is reason for believing that some similar form of mechanism occurs in activities confined to the higher levels. It is not at all inconceivable that in preparing for the execution of a voluntary act inhibition may be converted into excitation or vice versa.

We have already suggested the advisability of studying the various activities of individual organisms in relation to the immediate environment and this is particularly desirable in connection with inhibitory functions. These special activities, forming a part of the phenomena of volition in man, are often spoken of as if they were independent of external forces and are frequently described as if they were special manifestations of some mysterious vital force. A careful analysis, however, of the fundamental inhibitory mechanism will serve to demonstrate once again that both internal and external factors are immediately responsible for

\* Knowlton, F. P., and Moore, A. R., "Note on the Reversal of Reciprocal Inhibition in the Earth-Worm," *Amer. J. Phys.*, 1917, XLIV, p. 490.

conditioning all types of adjustment. The external world or environment is constantly imposing conditions limiting or interfering with all forms of responses; even with the so-called reflexes,\* which are generally thought to be altogether independent of outside influence and to a large extent invariable.

Experiments have been conducted with a view to determining in dogs the inhibitory influence of such factors as sound, color, and odor in modifying glandular activity; for instance, in inhibiting the secretion of the salivary glands. Desistent phenomena of this kind reveal the intimate vital bearing of both endogenous and exogenous factors upon the entire process. Even in such a simple process of adjustment as watering of the mouth at the sight of food many factors both within and without the individual must be estimated in order to get a clear idea of the nature and genesis of the phenomenon. If the principle enunciated is of value in analyzing adjustments at the lower levels—reactions that seem to be rigidly determined and fixed—it is more pronounced in the variable complex of consciousness, which are too often studied as if detached processes. Pawlow† inclines to the belief that sleep is probably induced by the incidence of a reflex conditioned by external factors and, in some way not yet explained, serves to bring about the complete arrest of activity of the higher cerebral centres. It is possible that in hypnotic states there may be an incomplete checking or inhibition of the higher functions of the brain, probably by the interference of the mechanisms located in the regions of the thalamus and other structures.

The investigations of Sherrington and his pupils have strongly emphasized the fact that to understand the nature of the restraining or inhibitory process it must always be considered in relation to the associated excitation, but this precaution has been rather ignored by many psychologists when discussing the more complicated volitional processes.

\* Pawlow, J. W., "L'inhibition des reflexes conditionelles," *J. de Psychol.*, 1913, January-February.

† Pawlow, J. W., *opus. cit.*

The two types of activity represented by synthesis and inhibition are so inextricably mingled that they can neither be sharply differentiated nor their nature understood unless the mutual relationships, interactions, and interplay are considered. For this reason the analysis of exceedingly complex physiological processes, such as those forming the basis of volitional choice or the elements determining our sense of freedom of will, is almost impossible if approached only from the psychological view-point.

The preservation of the normal tonus, so important for all responses, is dependent upon the apparent antagonism between muscles or groups of muscles. In the case of a purely muscular response to stimulation the character of the reaction is the result of the preponderance of one set of stimuli, but in the higher levels of thought more complicated conditions, involving an interplay of "motor sets," are the result.\*

The phenomena of the reciprocal co-ordination of muscles, as explained by physiologists, are exemplified by Descartes's classic exposition of the reciprocal co-ordination occurring in the eye movements,† where the outward movement of one eye is accompanied by the inward swing of the other. Here it is obvious that the tonus of one centre is inhibited in both time and step by the excitation of the other. It is quite conceivable that this reciprocal response between the agonist and the antagonist muscles might fail, with the consequent interference of the normal movement, and with the further result of blocking by this derangement a simple volitional response. Whenever such disorders occur in the apparatus there are many changes induced in the execution of the general schedule of voluntary activities. Definite groups of muscles may fail to respond in a co-ordinated manner to the incident stimuli, with a resulting condition such as apraxia, where the execution of simple movements, while not impossible, prevents the integration

\* MacCurdy, J. T., *Psychol. Bull. N. Y. State Hosp.*, 1916, IX, p. 500.

† Bayliss, W. M., *Principles of General Physiology* (Longmans, Green & Co., London and New York, 1916).



of functions of groups of muscles. Apraxia seems to depend upon the increased difficulty of establishing a close relationship between the conscious representations and actual movement; a condition that results in cerebral dystonia, which is quite distinct from tabetic atonia or the hyper-tonia accompanying spastic conditions.\* In some cases where these disturbances in the execution of simple voluntary movement have been noted lesions have been found in the regions of the lenticular nucleus, regio subthalamica, red nucleus, and in the cerebellum. Experiment has shown that, although reciprocal innervation is readily obtained from the cerebral cortex, the cortex is not really indispensable for the reaction. There are certain reasons for believing it both possible and probable that there are cortical elements possessing the function of inhibiting the action of other elements. When a given set of muscles are actively innervated the antagonists are actively inhibited, and the reciprocal relation is established by the spinal cord; but the reaction may also be elicited from the cerebral cortex. The arresting action follows here the intervention of sub-cortical centres.† These mechanisms, however, represent a part, not all, of those fundamental in complicated responses. The rôle played by the cortex becomes, of course, proportionately greater in very complex volitional responses.

We acquire additional insight into the nature of the various mechanisms forming the basis of the voluntary processes by carefully studying the reactions of the lower animals. It is evident, for instance, that the primary emotional responses, at least the parts into which the primitive instincts enter, are often more pronounced in these animals than in man. And more than this: light is thrown by them upon the processes by which these responses, virtually protective in character, have been acquired. Earlier in the

\* Van Woerkom, W., "Ueber einige Störungen in d. Ausführung einfacher Willkurbewegungen," *Ned. Tydschr. v. Genoesk.*, 1915, pp. 1579, 1671.

† Wilson, S. A. R., Walsche, F. N. R., "The Phenomenon of 'Tonic Innervation' and Its Relation to Motor Apraxia," *Brain*, 1914, XXXVII, part II.

chapter we have noted that in the course of the phylogenetic development a certain selection has taken place, and gradually, by the process described in Chapter III, a complicated apparatus, the cerebral cortex, has been developed which becomes an important part of the inhibitory mechanism. Under the control assumed more and more by this organ the intensity of the original response is reduced by subordination. In disease, however, the reducing power of the cortex may be impaired and allow the impulses phylogenetically older a chance to break through the restraint, so that under certain conditions a highly civilized man may suddenly give expression to responses indicative of his inherited simian traits. Possibly some of the phenomena generally described as perversions may be merely the cropping up of functions phylogenetically older than those in common use.\*

It is impossible to go very far in analyzing the composition of the voluntary responses without being compelled to trace some directing force which has its roots deep in the instinctive life, to a point where it seems to form the foundation of the entire complex. Just here it is desirable to note the influence exerted by impulses of a relatively low order over the voluntary control. In periods of mental unrest and discontent with life there is ample opportunity to study its effect upon the entire personality complex.

We cannot form any idea of the psychological processes involved in securing voluntary control if investigations are limited to a superficial inspection of these reactions in relation only to conscious activity. We need a method that will be of definite value in our search for the factors responsible for the acceptance or rejection of the ideas conditioning voluntary activities. If our purpose be to find the springs of action and to form some clear notion of what really happens during the process of valuating ideas prior to the final choice, it will be necessary to trace also the genesis of many of the effects and affects connected with the satisfaction of various social needs.

\* Hatschek, E., *Jahrb. f. Psychiat. u. Neur.*, 1914, XXXVI, p. 229.

Comparison of the behavior of the higher with the lower forms of animal life demonstrates the elaborated and perfected control of the former as dependent upon the increase of those subtle processes, including inhibitions, collectively designated as intelligence. In man these functions are very clearly illustrated in the special aspects of his personality and are the determining and controlling forces in action. All the means by which intelligence assumes control of the higher planes of reactivity are represented in the group of activities collectively designated as the will. But it is a mistake to believe that this group may be considered as independent of all other functions.

Man is but one link in the animal series. The greater correlation, co-ordination, and association of his mental processes is marked by increased intelligence. His progress in civilization is also due to the gradual extension of this intelligence and to the subordination of the voluntary responses to rational control. The highest type of personality is therefore to be regarded as the product of the forcible control of all voluntary activities by intelligence.

The realization that the phenomena of will were no longer to be regarded as representing a fundamental or single type of the psychic processes brought with it significant progress in the study of the volitional processes. A second contribution to the study of human behavior was the demonstration of the fact that feeling is a dominant factor in all volitional processes; and, finally, when the general biologic setting of all voluntary reactions was taken into account the complex character of the phenomena included in the voluntary reactions was formally recognized. To-day we believe that from a standpoint of practical experience the will may be said to include all cerebral processes into which consciousness enters and which direct toward some definite goal. In this complex group *feeling, valuation, and motivation* are important factors.

Groups of subsidiary processes are to be distinguished in connection with all voluntary reactions. The first includes those connected with the valuation and has reference to the

forces shaping the course of behavior, while the second, motivation, has reference to the resulting movements. Both subjective and objective reactions are part of the integration under consideration. Our interest is centred in studying the actions, past and present, or contemplated, which enable a person to substitute for ideas, objects or events. Both sets of functions express a relation between the organism and environment and Holt has stated that no sharp distinction should be admitted between "function, wish, and purpose." In each case the processes of differentiation are discrimination, the release of energy in free, unimpeded action, or the suppression of part of it. The complications incident to the suppression are the phenomena that require special consideration, since they are the chief factors concerned in volition.

The entire will process varies greatly in its expression, so that impulses, motives, decision, and execution are often so inextricably blended that in exploring the personality it is impossible to differentiate one from another except by those arbitrary distinctions so frequently met with in parano-mastic phraseology. The entire elaborate process may be begun and ended so rapidly as to resemble the short circuit of an electric current.

Purely an arbitrary choice must determine the point at which we begin the study of volitional reactions. We have seen that inhibition cannot be discussed satisfactorily without reference to excitation; and this latter process in turn cannot be isolated and considered without taking into account the factors in the life of each individual which raise or lower the threshold of stimulation, giving increased sensitivity for one group of stimuli and diminishing it for others. Suppose we decide to explore all the forces operative that result in one man's decision to go out for a five-mile walk in the sunshine while a second prefers to sit in an easy chair at his club and smoke a pipe. We shall immediately find ourselves obliged to review the life history of each, and include also a survey of their inherited tendencies, since such investigations, to be of value, need an

elaborate personality study. We must also inquire into both personal traits and the relation of them to the environment. In each instance we need to know all that is possible about the influences giving direction to both desire and choice. We should find it necessary to have some idea about the character of their reactions not only in facing pleasurable and annoying situations but also as to the forces at work which make a situation agreeable to one and unpleasant to the other. The more actively we search for the *vis a tergo* which controls the behavior of pedestrian and club-man, the more involved do we become in exploring biologic as opposed to purely psychologic principles. Another wide field of investigation would present itself were we to attempt to ascertain the reasons for the apparent loss of voluntary control as soon as a nervous person develops a strong antipathy for a chance acquaintance. Immediately all conventional forms of restraint may seem to be obliterated, and little attempt is made to conceal the evidence of intense dislike or hatred. With persons of unstable emotional equilibrium we often see the reversion to the lack of emotional control shown by young children. All such cases illustrate the trends resulting in differences of behavior.

In gathering data for personality studies it is well to remember that the desire to follow one line of action in preference to another is not by any means immediately conditioned by the feelings. In disease we often find illustrations of the fact that feeling is not directly expressed in the strength of the desire. The driving power of desire is often greatly increased, even while the sense of pleasure is correspondingly diminished. The reason for the pedestrian's decision to walk in the sunshine or for the club-man to lounge in a comfortable chair is by no means conditioned only by pleasure or ease immediately experienced or anticipated.

Two other instances in which a decision involves another kind of choice illustrate important aspects of behavior. One is that of a person who has decided to amass great

wealth, and the other of a man willing to forego many personal comforts in order to accomplish such a definite object as assisting in the improvement of municipal government. How are the "values" determined in these cases, and what gives them their impelling force? In the first man we cannot consider the deficiency in humanitarian instincts as merely a negative influence. Certain "value movements" have been as active in shaping his attitude toward life as they have been in the second case, where preference has been given to a line of action that seems less egoistic and selfish. The relations of both men to society must be analyzed to understand the nature of their evaluation of different lines of behavior. We shall also find that the act of deliberation which is connected with the final decision is linked up with the process of evaluation and is not connected immediately with motivation. Motives are the conative tendencies to act and they are not translated into action so long as the arresting part (inhibition) of the process of deliberation interferes. But here we may note that it is hardly correct to speak of a conflict of motives because motives connote tendencies to act.

At this point we may add to what has already been said about the relation of feeling to voluntary responses. Feeling is a term which is applied so indiscriminately that its meaning is usually vague rather than exact. While writing these lines I feel the pencil, the smoothness of the surface of the table, a sense of annoyance that my ideas should be so slow of development, as well as a sensation of hunger telling me that it is almost time for lunch.

By this we see that feeling is a broad term, including, as Ward has remarked, relations to antecedent pleasant or unpleasant situations, and that therefore, unlike a sensation, it is not confined to the experience of the moment. These situations may either cause the feeling or be the end in view toward the accomplishment of which feeling drives the experient. In connection with feeling it is well to remember that the direction of the stream varies each time our sensations change. One set of feelings dominates now,

while my eyes are fixed upon the paper, but the moment I look out of the window and see the clouds and trees quite a different set of feelings takes their place. There is ground for scepticism, however, in regard to the position taken by some psychologists that a change in feeling is always preceded by one in sensations; although it is not improbable that the shifting of my eyes from the table to a view through the window may be the result of discomfort due to slight fatigue which a shift in the attention relieves.

Another important question to determine is the extent to which the ideas in consciousness giving direction to the volition are evolved from primitive feelings. This is a territory needing additional exploration, since much of the present confusion between the relations of consciousness and feeling is due to the difficulty of defining the two terms. We are reasonably certain only that feeling, like attention, is invariably present, but lacks definite characteristics which lend themselves readily to description.

There is often, too, some difficulty in differentiating the elements of feeling from the more complex emotions, but we must not permit arbitrary distinctions to be an embarrassment to our study of them. To find a satisfactory explanation of the dominance of one line of conduct over another is still a problem for future work. We only know that there are numerous links in the chain by which motor responses are connected with sensations by means of an interplay of feelings, the analysis of which is baffling.

The muscular system, the silent partner in these voluntary reactions, must not be overlooked in our analysis of them, because of their directive influence in determining the character of the responses. There is a very intricate arrangement of functions, which may be called auxiliary-motor, by which we are enabled to perceive spatial relations; and these should be very carefully distinguished from the other indispensable factors that convey an idea of the force entering into movement. Relatively slight disturbances in these functions may disorganize the system of volitional control. The term *dirigo-motor*, although con-

noting a part played by these special functions, has been used in quite another sense, so that, to avoid confusion, it should not be used to designate these special functions.

The mechanisms by which an idea of the position of our limbs and body is revealed to us, as well as of the velocity and extent of movement, are at the basis of all voluntary adjustments. Their unobtrusive character is scarcely commensurate with their value in determining the character of behavior. The sense of effort or of ability to overcome resistance is closely associated with these phenomena and is concerned in carrying out every kind of movement; being an important part of the basis of all the higher forms of adjustment. The motor presentations connected with the performance of all movements are more immediately associated with the carrying out of normal reactions, while organic sensations, on the contrary, generally become prominent in consciousness only when disturbances occur in normal functions.

The sense of effort developed whenever a certain degree of resistance has been overcome is one of the principal factors concerned in giving us our idea of external reality and of keeping us in contact with our environment. When through a condition of fatigue the sense of effort becomes exaggerated there may be a marked change in the personality; the person is irritable and depressed, and unless the condition is relieved there ensues a marked change in the character of the volitional reactions; or there may follow a decided limitation to the person's insight into his own condition, very noticeable in connection with the more complex volitional processes. For example, there is strong disinclination to undertake anything demanding much concentration of thought or firm purpose in action. Such a condition naturally reduces the points of contact the individual has with his environment.

In a later chapter we shall refer to the importance of the motor set in determining character by noting the relation between habitual motor reactions of a person and his conduct expressed in the events of his daily life.



Many illustrations could be cited from the experiences of aviators to show the dependence of voluntary choice upon the proper adjustments of functions in the lower levels of adjustment. The balance necessary for normal voluntary reactions may be disturbed by slight disorders in functions not ordinarily assumed to have a very close connection with higher types of reactions. For example, the control of voluntary activity so intimately linked with perceptual processes may be very quickly upset by disorders of sense-perception. And comparatively slight derangement of vision, audition, or the kinesthetic sense may give rise to lack of confidence, loss of judgment, and other changes in the personality indispensable to the flier for maintaining his efficiency and for protecting him against accident.

In the aviator also there is an excellent opportunity to trace the connections between the different phases of the voluntary processes. On the one side are the movements, objective reactions, while on the other are the subjective phenomena represented by thought processes and feelings. A very slight disturbance in the biological balance may seriously interfere with the ability to shift quickly the level of adjustment from reflex to voluntary or vice versa. Among the many conditions responsible for this difficulty in shifting gears we may mention fatigue and "staleness." When symptoms of the latter develop it is very evident that the mechanisms concerned even in reflex adjustments are out of order. Changes in the pupillary reactions occur, the significance of which is not yet understood. A sign of fatigue may also be noted in the alterations taking place in the peripheral circulation demonstrable in connection with dermagraphia. Associated with these objective signs is the undue anxiety of the aviator who is inclined to worry about non-essentials and shows less ability to repress the memory of personal troubles. When his voluntary processes undergo analysis there is evident much difficulty in evaluating ideas, with consequent perplexity and nervousness when called upon to make a prompt, intelligent decision in the face of a critical situation. In such cases we must have more

detailed studies of symptoms and subjective reactions, together with a knowledge of the causes which increase the difficulty of the level of adjustment from automatic to voluntary reactions or vice versa. And in fatigue states there is a splendid opportunity to study the automatization of voluntary responses.

A phenomenon very closely related to automatization is that of perseveration or iteration; the repetition of deeds or words. This may occur in either a connected or a disconnected manner. If it is the former, certain words or acts are repeated without any break; but if it is the latter, the continuity is broken by the intrusion of other processes with a recurrence of periods marked by the perseveration tendencies.

It is desirable to recall some of the chief points connected with the phenomenology of the will (voluntary action) to facilitate the study of individual cases. Four phases in the entire process may be blocked out.\* The first is one of expectancy, characterized by increased tension; the second marks the instant when the sense of effort enters the field of consciousness; the third begins with the recognition of the end or goal to be attained; and is followed by the fourth and final event or decision expressed in the "I will." These distinctions, however, must be recognized as purely arbitrary, as the different events are so closely associated as at times to be incapable of separation.

We may distinguish three types of inclinations or predispositions that determine the final choice in volitional acts. The first is a reaction on a plane but slightly above the ordinary automatic responses, with only a vague motive or incentive, while the act follows immediately upon the exciting stimulus. The second, in a slightly higher grade, brings with it a feeling of compulsion, the result of some foreign influence; and closely linked up with this is the third, in which the general emotional tone is clearly defined. There are all grades between this type and the

\* Ach, N., "Ueber die Willen," *Untersz. Psychol. u. Philos.*, 1910, I, p. 10. Also: *Ueber den Willensakt und das Temperament* (Leipzig, 1910).

most complicated responses into which the idea of purposefulness and significance of the end in view enter as prominent elements.

From a careful study of individual cases it is obvious that the actual determination of the volitional choice may be induced by what seems to be a purely affective state; but, as a rule, this only occurs in persons in whom the processes of ratiocination and judgment are not highly developed, or in those whose mental processes have been impaired by disease. While the actual decision in volition seems to be dependent upon the consideration of the purpose of the impending act, in some instances it has the appearance of being the result of external influences. But the real set responsible for the reaction depends upon much more subtle biologic causes.

When we state that the voluntary effort may be conditioned largely by intellect, this does not discount the influence of the emotional factors but only reduces them to their proper value in the whole complex. It is practically impossible to establish fixed criteria for measuring the strength of any given motive; each case must be judged upon its own merits; and the conditions in the same person vary at different times and under changed situations.

We have just begun to appreciate the intimate reciprocal relations between the volitional responses and the activities controlled from the subconscious levels. People who suffer from decided fluctuations in the stream of attention are deficient in voluntary effort. It has been suggested that this is the result of pre-images bordering the field of attention and preventing others from developing sufficiently to gain permanent ascendancy; and consequently the more persistent the conscious effort to focus the attention the greater becomes the indecision and vacillation. For this reason we often hear of the successful solution of a problem after the attention has been completely diverted from the special object that has so long baffled attempts to master it. The key to this situation is often lodged in the subconscious, the preparation necessary for the completion of

voluntary actions being carried far below the higher levels. Could this principle be thoroughly realized it would often be used to advantage in education. Sometimes pupils who seem to be quite obtuse are able to conquer difficulties when these subconscious activities are given a chance to complete their functions. But this phase of our subject we shall take up in connection with the discussion of dissociation.

The recognition of some of the phenomena connected with the voluntary responses is sometimes aided by reference to some such general plan as the following. First, a careful statement should be made of the dominant characteristics of the prevailing emotional tendency, whether pleasant or unpleasant. This should be followed by noting the intensity and probable duration of the conditions influencing the affective state, weak, strong, or intermediate. The ease and rapidity of adaptations, are also important to observe, as also the general condition of irritability, whether marked or slight. To these observations should be added a statement of the general relations of feelings to acts, pleasant or unpleasant, the dispositional trends such as quality of the feeling, capacity for being easily or with difficulty aroused, the intensity and persistence of reactions slight or excessive, and, finally, the nature of the accompanying movements and the changes either in the blood supply or functions of the nervous system.

For purposes of aiding in clinical study two different types of cases of anomalous volitional activities may be noted. One type frequently observed is represented by people in whom the initiative is feeble or wanting, and a second in which there are a few strong but uncoordinated and uncontrolled impulses. The former group includes the so-called simple disorders of the will characterized by a lack of initiative, defective capacity for continuity of effort, and irresoluteness of character. As a rule, these symptoms are sufficiently indicative of the fact that the individual has not acquired the capacity to adjust his activities at the highest levels. Again we may observe persons whose

volitional activities are evidently greatly impaired by the diminution in driving power generated by the definite motive.\* In these cases there is generally coincident decrease in many of the emotional reactions. Very often it seems as if the sense life of the individual had not developed, and as if there were actually not enough sense-impressions to fire the reactions.

We have spoken of the fact that impairment in the receipt and transmission of sensory impressions, as in the case of blindness or deafness, also interferes with the generation of motor impulses. When, too, great limitations have been imposed upon the development of the sense life, the people afflicted are occasionally incapable of responding to ordinary pleasure and pain stimuli. They are generally described as apathetic, irresponsive; and when as children they come under observation in schools teachers are often perplexed to know how their interest may be aroused and an impetus imparted to the sluggish stream of their activities. The exaggerated forms of this type are generally recognized without trouble and are sometimes found to be associated with defects in the intellectual sphere. The less marked cases, however, although they are of frequent occurrence, are seldom recognized and practically never receive the sympathetic and intelligent care that they deserve. Another group of cases, familiar to parents and teachers, includes children whose respiratory passages are blocked by adenoids and who cannot breathe through their noses. The absence of initiative and general apathy of other children may be the result of a variety of different physical causes.

The reactions of patients belonging to the second type are in marked contrast, since the chief defect of these is not lack of initiative but one of diminished inhibition associated with excessive impressionability for external influences and characterized by quick and often exaggerated responses. The trend of activities in these cases seems to

\* Birnbaum, *Grenzfragen des Nerven- und Seelens-lebens* (Bergmann, Lowenfeld, Wiesbaden, 1911, Bd. 12, H. 77-82).

be often determined by conditions chiefly outside of the individual and is expressed either by lack of self-control or an incapacity to direct intelligently their volitional responses. As the result of excessive impulsion, domineering moods and stormy reactions sweep away all resistance, and because there exists such an exaggerated degree of irritability for all incident stimuli there is no continuity of effort in any one direction. External impressions also dominate their activities as easily and rapidly as each change of the wind swings the weather-vane into a new position.

A certain period of time is essential for the completion of any volitional act. If the process is initiated and ended within a limited period, it is described as normal or abnormal, according to the empirical standards selected for measurement. Great variations may take place in the duration of the process. The cause of the delay may be the result of the interference taking place at one point and again at another in the long chain of mechanisms. Whenever the delay is the result of an inability to reach a decision a state of anxiety or fear and a more or less complete disorganization of the personality may follow. Such phenomena are occasionally observed in conditions of fatigue. Who is there who has not experienced the doubts and reluctance to act that often paralyze efforts when, after a protracted period of physical exertion, the attempt is made to face critical situations? Ambitious and sentimental mothers have been known to express the desire that their children's will-power, already impaired by excessive and protracted periods of study, and giving evidence of having acquired the peculiar stubbornness characteristic of neurasthenics, should, to quote their words, "be broken," in order that there should be a complete realization of what it is to have a will of their own! Individuals are often observed struggling "to strengthen" their rapidly vanishing will-power by subjecting it to unnecessary strains at a period when the time should be devoted to laying up reserve stores of energy to be drawn upon in meeting the ordinary exacting situations of life.

The wards of every hospital contain excellent opportunities to study the serious interference with the voluntary processes which follows the emotional disorders incident to changes in physical condition. In the various states of anxiety accompanied by depression, pessimism, excessive irritability, and other indications of serious impairment of the emotional balance are found numerous illustrations of these disordered activities. French clinicians stimulated by the observations recorded by Morrel in his work entitled *Délire à Motive* have paid particular attention to the correlation between the various changes in the physical states of a patient and the corresponding alterations in the emotional attitudes in voluntary reactions. Recently other observers\* have continued the investigations along this same line and have produced additional evidence as to the importance of continuing to try to demonstrate the correlation between the disorders of the will on one side and the disturbances of the physiological functions upon the other. At present we are only at the beginning of our investigations and for a long time to come many of the links in the chain which connects the mental and physical disorders will be absent, but these gaps should not in any way make us underestimate the importance of the investigations. Much more attention should be devoted in the wards of the general hospital to such studies, since it is often true that little of value can be obtained from the exaggerated cases of disordered volition which appear in connection with advanced stages of mental diseases.

In contrast with the cases in which there may be some functional impairment in the sense-organs there are those in which there seems to be a decided increase in the irritability for sensory impressions coupled with an associated exaggeration of the imagination. Experience favors the view that people who seem to be easily impressed by visual stimuli, and particularly in the form of color, are apt to have a vivid imagination and not infrequently exhibit a ten-

\* Devaux, A., and Logre, J. B., "Les Anxieux, Études de Psychologie Morbide" (Publié sous la direction de Dr. E. Dupré, Masson & Cie., Paris, 1917).

dency to forsake fact for fiction whenever the opportunity presents itself of awakening the interest of friends or willing listeners to their entertaining and picturesque narration of the ordinary events of life. Their sense-impressions are so unusually vivid that the control of the inhibitory mechanisms is diminished. It is a singular fact that some persons who within certain lines have developed an exaggerated form of scrupulosity in regard to telling the truth seem to be quite oblivious to all standards for veracity when an event makes an appeal to their imagination that they wish to describe. It would be very interesting if this type of person could be observed during the development of the sense life and closely studied during the first years of school life. Some men are semiconscious of a defect in their ability to give adequate expression to their activities, but are eager to use their active imagination in concealing their shortcomings from both themselves and others. When their intellectual capacity is not impaired, complex mechanisms so quickly hide their defects that in adult years it is impossible to determine the starting-point of the disorder. There are also other persons who show very plainly in their volitional life a defect that is apparently dependent upon a perverted sense of reality. They live largely in a world created by their own imagination and one in which there is likely to be a tendency to magnify greatly the minor incidents of daily life (autismus).

A somewhat similar disposition to distort facts may be observed in children showing a tendency to lie. The mendacity is often produced by partial amnesias, mechanisms inhibiting or rendering difficult of recollection their acts or words, or by illusions as to the duration or date of past events; and in some cases by hallucinations of memory.\*

Lying may be a symptom of disordered adjustment in a type of child who otherwise has a most attractive personality.† To others the picturesque character of lies seems to

\* Healy, W. and M. T., *Pathological Lying, Accusation and Swindling* (Little, Brown & Co., Boston, 1915).

† Guilhermet, "Les mensonges des enfants devant la justice," *Rev. d. Psychother.*, 1911, XXVI, p. 35.



make a particular appeal. We all know this type, high-strung, unduly sensitive to certain kinds of stimulation, indisposed to accept either pleasure or pain with restraint, craving sympathy and thoroughly unselfish so long as the gratitude given is in excess of the service rendered. Such a one begins early in life to compensate for inadequacy by an exaggerated egoism; he is soon conscious that unless ready to furnish excitement or amusement he cannot expect to attract attention. With the failure of attempts to amuse or interest there follows a resort to stirring up sympathy or to attracting notice by the narration of a long list of misfortunes. The habit is so speedily formed and so scant is the attention it receives from those who should be ready to remove its causes that a child may acquire those peculiar emotional and intellectual qualities that in the end may make of lying an art.

Adults, too, may possess "a strong will-power" along certain lines and yet have a strange incapacity to tell a straight story. Such people may have a keen sense of justice and rectitude and when holding positions of trust may evince an almost too great devotion to its cause, while at the same time they may exhibit a total disregard for accuracy of statement about their own personal affairs. Some of the garret philosophers who speculate freely about the problems of the will would do well to turn their attention to such instances. Deductions made from the volitional life of these varied types should, if carefully drawn, afford a valuable quota to our knowledge of the activities of mankind.

For centuries much confusion and many misunderstandings have arisen in regard to the so-called problem of the freedom of the will. So long as we persist in studying the series of problems described under this heading from one point of view the controversy is interminable. When, however, we adopt the expedient of approaching the subject from the standpoint of general biology we are surprised to find how little remains of controversial nature. John Locke\* opened up this new line of attack when he affirmed

\* Locke, John, *Essay concerning the Human Understanding*, II, XXI, 21.

that the real question in the controversy was not "whether the will is free but whether the man be free." The adoption of this suggestion results in shifting the attack from specially prepared positions to the consideration of the general biological principles governing the behavior of human beings, and therefore marks an important advance in this field of investigation.

We have no intention of entering into any detailed discussion of the terms employed in this particular controversy, but desire merely to indicate one or two important points which should not be overlooked in conducting the examination of concrete cases. In the first place the sense of freedom which an individual experiences in following a certain line of voluntary action is a variable quantity and depends upon a variety of circumstances. Whenever the customary vitality of any person is lowered there is a decided impairment in the sense of freedom. This principle is illustrated in conditions of fatigue and in various depressed states occurring during attacks of disease, when restrictions are placed upon spontaneity of action so that we recognize the fact that the person in this condition is not capable of the higher forms of volitional activity.

It is well just at this point to explain that, when we say a person is free to act, this phrase calls attention to the very hearty co-operation shown in following a certain line of action. In self-determination the individual is still forced to make a choice and is only free in the sense that the decision rests with him. In order to understand to what extent reason is a determining factor in volitional control we should be prepared to study the entire personality, take note of its relation to environment, and have some understanding of the factors which have determined its growth. We should not forget, in making these studies, that there is always an interaction between the subject and the environment, so that both are influenced by the changes taking place either in the internal or external conditions.

Moreover, the idea that there is a "free will" more or less independent of all laws governing the physical universe

is a purely theoretical conception and has had an unfortunate influence in shaping opinion upon many social problems. A normal sense of freedom is found in persons possessing some considerable degree of intellectual activity and having happily the sound body that predicates a sound mind. Those who are fortunate enough to measure up to certain physical and mental standards may consider themselves to be, within reasonable limits, the architects of their own fortunes. Most of the advocates of the theory of free will have seldom had opportunity to analyze thoroughly and sympathetically the activities of people representing various epochs of individual development or different stages in those imperfect adjustments occurring in disease. The philosopher reflects in his study upon the number of persons, a relatively small one, who possess a sharply defined feeling of freedom, and as he has never been brought in contact with the greater numbers that show a restricted sense of volitional independence he naturally formulates a law relating to the minority. "Volition," wrote Huxley, "counts for something as a condition in the course of events," but our small knowledge of the nature and comparative importance of factors determining voluntary action should remove the temptation to block investigation in one of the most important fields of inquiry by diverting the stream of attention by positiveness of statement about it.

The insane, the feeble-minded, and the idiot are no longer compelled, as was the case a century ago, to suffer the tortures of the damned because society insisted upon a rigid application of the doctrine of free will as an essential test in deciding upon the proper recipients of charity. We also give the child the benefit of the doubt in attributing to it a relatively low degree of freedom and remove the box of candy from its reach rather than trust to an innate desire to be good. We pray for the adult that he may be spared temptations, but if they come the futile efforts to resist are often rewarded by administering a retributive form of vengeance called punishment. Of course, we have

no intention of ignoring the fact that the thought of punishment may also be sufficient to diminish pernicious activities; and in this way the influence of the environment is clearly recognized. Very often persons with latent vicious instincts do not exhibit them because the circumstances essential for the development of the traits do not happen to occur; therefore human beings, in spite of undesirable predispositions, may remain harmless members of society. Credit is due the clinicians for assistance in demonstrating the fact that each person has certain predispositions or attitudes and that the development of character depends upon the intelligent guidance given to the activities. These "sets" may or may not be expressed in overt acts, and collectively they represent a series of phenomena designated as the "will."

The investigator who has carefully studied individual cases will readily acknowledge the desirability of making a complete biologic study of the individual as the only means of acquiring data sufficiently detailed and reliable to form the basis for the successful revision of social and ethical standards. As an example of this need the following instance will serve. Two men are arrested on the charge of having committed murder. One of them is justly acquitted on the ground that he is mentally defective, and no intelligent person questions the evident justice in the decision of the court. The bestial qualities exhibited in the execution of the deed and the marked intellectual impairment shown upon examination are sufficient to indicate that in the eyes of the law the individual is irresponsible for his acts. In the second case there is no decided mental defect; on the contrary, a surprising degree of ingenuity and careful deliberation have been indicated in the manner in which the victim's life was taken. There is a possibility that early in life the offender had displayed many of the qualities described as attractive and lovable. He may have been an excellent illustration of the type of child to which we referred in describing the tendency to mendacity. Nothing had then been done by the state to discourage the develop-

ment of very dangerous propensities in him, although the full penalty of "revenge" is inflicted when the final act in the tragedy is executed. On account of the exceeding complexity of the mental processes which in our present state of ignorance cannot be successfully analyzed, the law declared the prisoner to be responsible for his acts. Logic and common sense are forcibly set aside in order that "man's not nature's law may be vindicated." To determine whether a murderer could or could not have refrained from committing the crime would require an accurate knowledge not only of all the events which culminated in the final act but also of the mental habits, motives, trends, and all factors giving their direction and set to the individual's activities. We neither elevate our own sense of moral rectitude nor give assistance to those who are slaves to their passions by assuming inflexible arbitrary standards of degrees of responsibility in order that an antiquated system of justice may be preserved. The retributive emotional states which have called forth our present penal system are the results of natural selection in the struggle for existence,\* and we should realize that, as altruistic sentiments take deeper root and have a more permanent effect in elevating the standards governing society, in the future justice will come to be regarded more and more in the light of an adaptive process which changes to meet the needs of society and to assist its betterment.

\* Westermarck, *The Origin and Development of the Moral Ideas*, vol. II, p. 739 (The Macmillan Co., 1908).

## CHAPTER VIII

### FACTORS DETERMINING THE TRENDS OF ACTIVITIES (DISPOSITIONS)

THE energy expended in adjusting life is directed toward (1) replenishing the store of energy, (2) insuring the growth and (3) safety of the organism, and, finally, (4) in providing for the reproduction and perpetuation of the species. This expenditure of energy implies movement, a current, or, as it is often called, *élan vital*. In man, as long as the current flows smoothly and the object for which the expenditure takes place is being realized, a sense of comfort and satisfaction is the result. If, on the other hand, the flow is impeded, very often a feeling of discomfort and an ungratified wish mark the disturbance of the biological balance and introduce elements of conflict into life. In the effort to restore the lost equilibrium the body must follow some course of action. In the lower animals this inclination gives rise to impulses, tendencies, attitudes as it does in man, but in the latter the intended course of action has still other phases variously described as wish, desire, purpose, etc.

In order to understand something of the conditions which are responsible for directing the stream first in one and then another direction we have to consider what it is that gives rise to individual predispositions and dispositions, including those inherited as well as acquired.

The final issue or product of a projected course of action is a definite trait. Traits\* are the functional representatives of predispositions, and their special significance is due both to the rôle they play in natural but critical situations and to the many complicated responses that they initiate.

\* Jastrow, J., *Character and Temperament*, p. 22 (D. Appleton & Co., N. Y., 1915).

Trends, of course, are indicative of the responsive capacity of the nervous system, but they in turn measure the intimacy of the relations and control exercised by the brain over the other organs of the body. They have, therefore, both a neurological and biological significance.

The general factors determining those predispositions or inclinations which stamp behavior with special characteristics may be designated as primary—those depending largely upon the normal growth and development of an individual—and as secondary—those occurring whenever the physiologic balance of an organism is seriously interfered with or impaired. The primary trends would naturally include hereditary influences, but as these cannot be discussed satisfactorily within a brief compass, they will not be considered in any detail at present. Many of the directive influences ordinarily associated with the development of human activities are connected with the growth of the organism. Forces tending either to insure or restrict the normal growth will have a corresponding effect in bringing about a comparatively perfect or imperfect adaptation, as the case may be, of activities at all the different levels.

Stockard has called attention to the possibility of correlating some of the principal physical changes occurring during growth with special qualities of temperament, character, and intelligence. In the case of such a type as the more or less slender, dolichocephalic person, with sharp, clear-cut features, bass voice, a tendency to hypermetropia, and well-developed emotional control in the presence of danger, the physical and mental qualities, emotional to a very large extent, are the result of an organization taking place during embryonic life and early infancy. The forces operating to determine the ratio between the linear and transverse growth of the embryo mould the structure and give direction to the physiological processes that are later expressed in the adult personality. In contrast with the type just mentioned, Stockard refers to the individual who has "broadened out" transversely and grows up to be more or

less stout, with pink and rosy complexion, a high-pitched voice, is less restrained, exploding easily under excitement, and has a marked myopic tendency. The proportion between lineal and transverse growth is probably influenced by the action of the thyroid gland. In the first type of person there is a hyper- and in the second a hypo-functioning of this organ.

From the study of the growth processes we not only get an idea as to the organization of organs and functions that are expressed in the individual personality, but we have some light thrown upon the more or less distinctive characteristics that distinguish the three chief races: namely, the Negro, Mongolian, and Aryan or Caucasian.\* It is probable that the functions of the five glands of internal secretion, forming, as Keith has said, only one one-hundred-and-eightieth of the entire structure, and which might be carried in the watch-pocket, have an important reaction in the production of definite racial characteristics. We should not forget, however, that the endocrine organs are not the only factors concerned in development. Many of the forces conditioning the dynamics of growth are hereditary and these are only modified secondarily by the endocrine apparatus. There are certain facts, however, which have been brought out by the study of diseased conditions that show, for example, a possible relation of the black, shiny, hairless skin, crisp hair, flattened nose, widely open eyes, heavily moulded lips, and prominent teeth of the negro with the functions of the endocrine system. The same is also true when we try to analyze the chief physical, emotional, and mental characteristics of the Mongolian and Caucasian types. We are only at the beginning of the study of the dynamics of growth, but the prospects are very promising for new and important discoveries in this special research both in the field of explaining individual and racial characteristics.

Additional information as to the nature of the biological

\* Keith, Arthur, "The Differentiation of Mankind into Racial Types," *Nature*, 1919, CIV, no. 2611.



processes concerned in development, maturity, and involution will not only elucidate many of the problems connected with the genesis of the primary trends, but will also throw light upon the origin of those inclinations that are the product either of abnormal development or of actual disease processes. The study of normal development, as we know, was only undertaken under the compulsorily aroused interest in morbid processes; and research into the nature and origin of pathological phenomena followed because the morbid processes, upon superficial examination, struck the imagination more forcibly than did the normal physiologic reactions of normal growth. We shall return to this subject later.

There are some general structural peculiarities or qualities of the elements composing the mechanism of adjustment, the nervous system, which are known to have significance in shaping the behavior of the animal. Probably the connection between the kind of reaction and the physical characteristics of the nervous elements is most direct in the case of certain types of movements considered with reference to the size of both nerves and cells. There seems to be some ground for believing that in the lower animals characteristically slow movements of groups of muscles are associated with cells and fibres unusually small in comparison with the muscles, whereas great rapidity and unerring accuracy of movement demand an increase in the size of the neural elements. In such an important protective response as that which occurs when sounds strike the ear and the eyes turn immediately in that direction, the mechanism is made up of large neuroblasts and large nerves. We may also say that up to a certain point the somewhat simple and unprogressive functions, which have persisted through the phylogenetic development without becoming either elaborated or more complex, are served by a neural mechanism composed of relatively small units. In some fish in which the responses are of a sluggish nature the nerve cells seem to be disproportionately small in comparison with the size of the nerve fibres, and possibly a

similar correlation may sometime be found for movements in man.\*

But correlations as definite as these are now known only in connection with the lower planes of activity. It would be most interesting and instructive to ascertain whether analogous conditions are found to hold true for the higher brain centres, and whether some idea of the structural conditions could be obtained from an analysis of the responses. In the more pronounced cases of imbecility, particularly in idiocy, there is a persistence of embryonic types of nerve cells in the higher brain centres, especially within the cerebral cortex; and the failure of many of these elements to develop is a prominent factor in this kind of defective mentality. Also, in the pathological changes taking place in such a disease as paresis, the reduction in the capacity to associate ideas, the partial or complete loss of the more complicated emotional reactions connected with the higher ethical ideals, and the low degree of intellectuality, all seem to be more or less closely connected with the diminution of the fibres of the cortical associational tracts, particularly of those in the outer layers, which phylogeny and entogeny have demonstrated were the last to be developed. A condition somewhat similar is also observed in connection with the changes in the brains of old people with senile degenerative lesions.

The system controlling the various lines of distribution and inhibition of energy in the higher animals may be compared to the switches and block system of a great railroad. The brain, especially the cerebral cortex, represents the office of the chief superintendent who controls operations and reports accidents or lack of efficiency.

To comprehend the workings of this complicated system we must take into account the relations and connections of its various parts. The elements in the case of human beings, as also of all other animals, are, of course, the individual cells, in each of which we see the repetition of the con-

\* Kidd, L. J., "Calibre of Nerve Cells and Fibres," *Rev. Neurol. and Psychiat.*, 1915, XIII, p. 409.

ditions in single-celled organisms. Every cell possesses the property of irritability by which an adjustment favorable to its existence is effected. Some writers, especially the French, distinguish between irritability and excitability, the latter representing the coefficient of the irritability and marking the stability or instability of the mass, a reaction occurring as soon as the equilibrium is disturbed. As the result of shifts in the physiological balance processes may be initiated that tend to restore the balance—in other words, to effect an adjustment. In the higher organisms the grouping of cells corresponds with the elaboration and specialization of function. The different reactions calling for the restoration of the impaired balance in man are marked by a variety of symptoms in states of health proportional to the strength of the stimulus and to the degree and extent of the response. According to their intensity and complexity they are categorically described as general sensitivity, reflex, instinctive, or emotional reactions, etc., being very closely associated with such adjustments as are concerned in making provision for nutrition, locomotion, secretion, and other processes of basic importance for the preservation of the life of the organism.

The need for differentiation and specialization of function in order to preserve and protect the life of the animal depends, to a large extent, upon the great vago-sympathetic system. This apparatus enables the higher brain centres to be kept posted as to what is going on within the body; but, so well organized are the functions and so unostentatiously is the control exercised, that under all ordinary circumstances the enormous complex of coenesthetic sensations remains quite in the background of consciousness. At present the chief fact for us to bear in mind is that these processes of adjustment taking place at the higher levels and giving expression to temperament and character are indissolubly connected with the nutritional, circulatory, and other physiologic functions.

Our inquiry into the origin of trends must not be limited merely to the study of the elements in the nervous system.

Only in a very narrow sense may behavior be considered as the expression of the functions of the brain and nervous system, since this great mechanism of adjustment is in turn influenced and to some extent controlled by the organs it regulates. The nervous system, it is true, establishes and maintains reciprocal relations between the different organs; thus, for example, when a reflex is referred to as the unit of nervous responses, this posits a complex relationship between a variety of organs. For example, if the flow of blood to the spinal cord is interfered with, there ensues a change in those reactions that under normal conditions may be regarded as somewhat stable functional units. Practically analogous responses might happen if organs other than those connected with the circulation were affected. As an instance we may cite the tuberculous infections of the organism, in which behavior is greatly modified by the secondary changes in the functions of the nervous system induced by the alterations within the lungs or other tissues primarily affected.

Definite specific types of activities, expressed in individual behavior and conduct, are the results of a great many factors that give a specific stamp to the reactions; and some of these have been mentioned in the references to the Endocrine System.

Recent investigations have thrown considerable light upon the organization of activities and the nature of the mechanism of control and regulation. Many organs seem to have relative independence of action, but, as a matter of fact, their functions are synthesized or focussed in a person's behavior. The sensori-motor or projicient nervous system is made up of paths for the transmission of sensory impulses to, or motor discharges away from, the brain. These nerves are immediately concerned in the execution of volitional acts. The nerve supply to the skeletal muscles shows at least one great contrast, as compared with the conducting lines of the "vegetative" system, including the sympathetic and autonomic divisions supplying the internal organs. The projicient system represents the mechanisms

that generally occupy the focus in the field of consciousness, while only under abnormal conditions do the "vegetative" functions, forming the background or fringes of the fields, rise to the level of conscious adjustments. Experience demonstrates that the intrusion of these latter elements is associated with the predominance of certain emotional reactions, and that the accentuation bears a strong relationship to the increased activity of endocrine glands; for example, thyroid and adrenals.

There are, of course, numerous other contributing factors which bear directly upon the problems of organization and which are responsible for the development of some trends and the repression of others. In health there is a balance maintained between organs supplied by sympathetic and autonomic tracts, marking the existence of close reciprocal relationships—a condition sharply contrasted with the phenomena of dissociation occurring whenever the functions of either of the two systems are interfered with. Often the "slowing down" or "inhibition" of the functions of one gives rise to symptoms equivalent to those following stimulation of the other. The same nicety of balance between, for example, antagonistic groups of muscles, such as flexors and extensors of the hand and foot, is similar to the balance of activities maintained between various organs. Any disturbance of this stability produces trends, first in one and then in another direction, that justify the comparison of the balance of the organism to the action of a pendulum which after a light tap swings easily to and fro until the equilibrium is restored.

The evident selectivity or varying sensitivity shown by the organism in response to stimulation is also in a measure determined by the functions of internal glands. The vegetative system thus exerts a great influence in raising or lowering a person's reactions for incident stimuli. Although this action of the vegetative system is indirect, it is none the less important. The trends of activity in all the planes are frequently regulated by processes seldom falling within the field of consciousness. Deeds or wishes ex-

pressed in love, jealousy, hate, utilitarian and altruistic sentiments, may be the results of emotional disturbances induced by these concealed complex reactions.

A comprehensive knowledge of human behavior, therefore, calls for the study of the separate organs, the elemental point of view, and also for an analysis of the reactions of the individual as a whole, the organismal concept. A comprehensive knowledge of any organ is obtained by observing its normal relationships with other parts. The adrenals, for instance, are so intimately connected by the nervous system with the pancreas as to preclude the possibility of a thorough estimate of the functions of the former without reference to the latter; so also it is impossible to measure the reflex effect upon the liver and consequent serious interference with its normal functions without taking into account the action of insufficient functioning of the ductless glands.\* The reciprocal relations existing between the organs of internal secretion have an important influence upon the emotional life, but these relations are far more complicated than is generally supposed.† The accompanying diagram calls attention to these reciprocal activities.

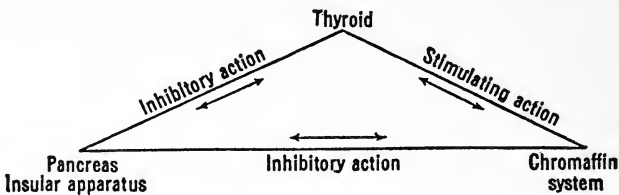

In conditions of health a fairly stable equilibrium is established between the internal organs that are closely related to the machinery of emotional expression. Some of these, like the thyroid, sex glands, and chromaffin tissues, have an accelerating effect (katabolic dissimulators), while others, like the parathyroids, hypophysis, cortex of the adrenals, interstitial glands, and thymus, retard the reac-

\* Whipple, G. G., and Christian, W. P., *J. Exper. Med.*, 1915, XX, p. 297.

† Gley, E., "The Internal Secretions," trans. and ed. by M. Fishberg, p. 185 (Hoeber, N. Y., 1917).

tion to stimuli (anabolic assimilators). We are fairly sure, too, that there is a close relation between the internal secretions and the activities of the brain and nervous system; but such a bond is very difficult to establish. When the physiologists are able to throw more light upon the part taken by the endocrine organs we shall doubtless be in a position to understand more about the mechanism underlying human character. When Abel succeeded, in 1897, in isolating the substance epinephrin, which has so powerful an effect in causing a rise in blood pressure, he made a positive contribution of value in extending our knowledge of physiologic chemistry and at the same time in explaining the reasons for some emotional reactions of great fundamental significance. From the physical standpoint we are, to quote Barker, "the beneficiaries and the victims of the chemical correlations of our endocrine glands,"\* and to some extent the question of temperament, character, and intellectual attainment is determined by the secretion of these organs.

Later we shall have occasion to refer again to the importance of the glands of internal secretion in giving the cast or direction to the play of activities, but our object now is to point out the reciprocating character of many of the functions of different organs.† Illustrations of this could be readily mentioned; they would furnish abundant evidence of the intimate interaction of all the organs, and emphasize the unity of the synthesis expressed in the various planes of activity. We have already seen how the personality is the synthesized product of many organs with mechanisms incapable of interpretation in terms applicable to one set of functions only, since personal traits of character are more than functions of the brain and nervous system.

The accentuation or repression of trends depends upon many circumstances. We must remember that the general principle concerned in the process of regulation is the de-

\* Barker, L. F., "On Abnormalities of the Endocrine Functions of the Gonads of the Male," *Am. J. Med. Sc.*, 1915, CXLIX, p. 1.

† Gley, E., *opus cit.*

velopment of an organ through use; whereas atrophy is the consequence of disuse. The hand may raise with difficulty the weight placed in it, but with a physiological increase in the capacity of the muscles there is a diminished sense of effort. This same principle applies also to the discharge of energy in all the levels and becomes an important consideration in the study of habit-mechanisms.

In the normal development of living organisms a certain physiological equilibrium is reached. In the case of the higher animals and of man, particularly in man's savage state, there is an ability to sense the establishment of this balance which does not seem to be retained to the same degree by the civilized races who generally live under abnormal conditions.\* Many of the impulses and inclinations giving a conventional stamp to man's activities are but secondary products of a destroyed equilibrium and indicate an imperfect development.

There is a level in the life of each person along which harmonious development takes place. This physiological equilibrium may be easily disturbed, and when this occurs the primary trends are replaced by those of a secondary or incidental character. In the present state of our knowledge it is often impossible to distinguish clearly between these two trends.

The constant interplay and regulation of activities in progress between forces tending, on the one hand, to accelerate and, on the other, to inhibit growth, is largely the result of certain chemical substances, called autocoids and chalones. Investigators have demonstrated how a remarkable modification may be produced in the processes of differentiation and growth by feeding portions of different organs, such as thyroid, thymus, or adrenals.† After the administration of thyroid there is a precocious differentiation of the various parts of the body, together with a re-

\* Du Sablon, "Les incertitudes de la biologie," *Bibliothèque de Philosophie Scientifique* (Flammarion, Paris, 1912).

† Falta, "Ueber Beziehungen d. Ueberfunktion z. Konstitution," *Zeitschr. f. klin. Med.*, 1911, LXXII, p. 97. Gudernatsch, "Feeding Experiments on Tadpoles," *Arch. f. Entwickl. Mechanik. d. Organ.*, 1912, XXXV, p. 457.



tardation of growth, in marked contrast to the conditions following the ingestion of thymus. Swingle\* has referred to the influence the thyroid has in determining both the extent and rate of differentiation in the growing organism. He has observed that if the thyroid is removed from a tadpole and implanted in another but younger tadpole of the same species the second one develops rapidly up to the point reached by the growth process in the first animal and then remains practically stationary. The duration of the larval stage depends apparently upon the activities of this organ. Inference points to the probability that in the higher animals, and in man, this organ, as we have already intimated, must play an important part in determining the differentiation of structure, the development of function, and the ratio between linear and transverse growth.

We have already pointed out that physiology and pathology give much evidence that the adrenals exert a strong influence upon the emotional life. Adrenalin, the active principle secreted by these glands, is known to have an extraordinary effect; acting through the sympathetic nervous system, it causes marked contractions of the blood-vessels, increases the blood pressure, and interferes with the movements of the intestines. Experiment has shown that, if the nerve supply to one of the adrenal glands in a cat is cut and the animal sees a dog, the characteristic anti-canine reaction occurs, but the gland, still under control of the nervous system, is depleted of adrenalin, the chemical substance with great influence over the emotional states by its effect upon the blood supply. Many other illustrations might be given of the close bond between the secretion of the internal organs and the regulation of the emotional reactions.† We must not take for granted, however, that the complete evidence of the reciprocal activities of these glands is demonstrable. Further investigation still remains to be carried on before the nature of the relations

\* Swingle, W. W., *J. Gen. Phys.*, Nov. and Dec., 1919, and *Trans. Amer. Assoc. Anat.*, April, 1920.

† Cannon, W. B., *Bodily Changes in Pain, Hunger, Fear and Rage* (D. Appleton & Co., N. Y., 1915).

can be made clear. We desire to repeat that a knowledge of the apparatus governing the regulation of the blood supply is of great importance for the understanding of the mechanism underlying the emotional life; thinking, feeling, doing are all maintained and controlled by the flow of the blood through the vessels of the brain. Some psychologists believe that the changes in the vascular system influence the strength rather than the quality of the effective states, so that we should expect a decided sensation of pleasure to be accompanied by a strong, low pulse; which, as a matter of fact, is generally the case. In the accompanying table an indication is given of the vascular changes with the associated mental processes.\*

	Brain	Surface of Body	Abdominal Organs	Limbs and Other External Parts of Trunk
Incidence in consciousness of idea of movement, with or without execution.....	+	+	-	+
Mental work.....	+	-	+	+
Fear.....	+	-	+	-
Pleasure.....	+	+	-	-
Pain.....	-	-	+	-
Sleep.....	+	+	-	+

+ Increase in blood supply.    - Decrease in blood supply.

The following scheme has been suggested as explanatory of the mechanism controlling the normal circulation.†

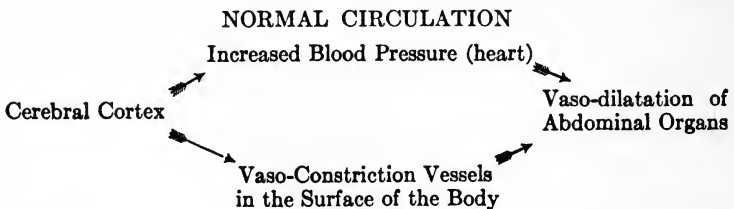

\* Weber, F., *Der Einfluss psychischer Vorgänge auf den Körper, insbesondere auf die Blutverteilung* (Springer, 1910).

† Bickel, H., "Ueber die normale u. path. Reaktion des Blutkreislaufs auf psychische Vorgänge," *Neurol. Centralb.*, 1914, XC, p. 90.

An impulse arises in the cerebral cortex and causes a change in the caliber of the blood-vessels. Another impulse starting from the vaso-motor centre in the medulla tends greatly to increase the activity of the heart with a consequent general rise of blood pressure. At the surface of the body the nerves causing constriction of the blood-vessels are stimulated to activity, and thus indirectly there is brought about a vaso-dilatation of the abdominal organs.

Under pathological conditions the result is quite different. The tract normally carrying the impulses directly to the vaso-constrictor mechanism in the external parts of the body becomes either broken or interrupted. The increase of the pressure in pathological conditions is high, and this causes a passive stretching of the vessels near the surface, with results indicated in the accompanying chart:

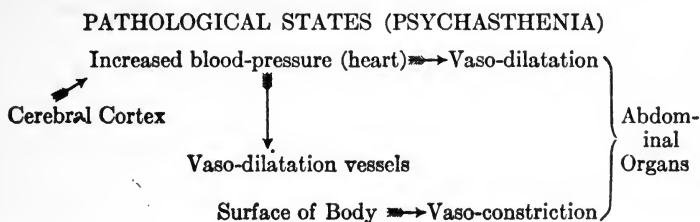

The nervous system being the great regulator of activities it is obvious that any considerable interference with neurological mechanisms is almost immediately reflected in various reactions. Sometimes the effect upon the brain or nervous system is easily recognized, but at other times the result is indirect and it becomes more difficult to trace out causal relationships. It is very possible that the conditions governing the cerebral system and therefore an intimate part of the mechanisms entering into the emotional states are far more complicated than this diagram would indicate.

A profound modification in dominant characteristics may be induced by the excessive or diminished secretion activity of glandular organs. Changes in the normal involutionary processes may also give rise to a very decided modification in behavior.

A good illustration of the effect of an organ in retarding the rate of growth and deeply influencing conduct is observed in connection with the pituitary body. The growth of young fowls has been inhibited by the addition to the diet of fresh unmodified extracts made from the anterior part of the pituitary body of the ox—a result more marked in the male than in the female.\* The relation of the pituitary body to certain pathologic processes disturbing the adjusting mechanisms is well known. Pituitary extract made from the anterior lobe when given to young rats stimulates both growth and sexual development, whereas the extract from the posterior lobe has a retarding effect. An ovarian extract (corpus luteum) stimulates sexual development in the female and has an opposite effect in the male.†

In abnormal conditions the symptoms vary greatly, depending upon the hyper- or hypo-activity of the thyroid gland. Very frequently there is such a blending of the two states that it is not possible to establish a sharp line of differentiation. In both the emotional and intellectual life the patients with disorders of this organ show pronounced changes, varying from a mild degree of nervous irritability to more profound alterations in the entire personality. It is well known that in pronounced cases of hyperfunctioning of the thyroid gland, commonly known as Basedow's disease, the symptoms are often so specifically characteristic as to be recognized by the laity. Less severe examples of the disease illustrate the effect of internal secretions in shaping the personality, without giving any marked disturbance of organic functions. On the emotional side there are noted increased sensitivity for some stimuli, exaggerated reactions, moods varying between euphoric conditions and those of depression; and these in turn influence the higher intellectual processes. Deficiency of function of this gland is attended by symptoms in strong contrast to those al-

\* Wulzen, R., "Relation of the Pituitary Body to Growth," *Am. J. Physiol.*, 1914, XXXIV, no. 11.

† Goetsch, E., *Bull. Johns Hopkins Hosp.*, 1916, XXVII, pp. 29-50.

ready mentioned, while severer cases culminate in what is known as cretinism.\*

In another connection mention has been made of the modifications in the processes of differentiation occurring when tadpoles are fed portions of the thyroid or thymus gland. The subsequent structural alterations are accompanied by equally striking variations in the responses of the animals.

Among other pronounced effects produced by internal secretions upon an individual's reactions may be cited the results of the transplantation of ovaries under the skin of castrated rats. The character of the responses undergoes a change and the typical male reactions are feminized. Recently much work has been done in connection with this important subject and the observations of Hatai† are especially worthy of remark. The results of his experimentation serve both to emphasize the value of analyzing the reactions of man and woman upon broad biologic grounds and to make clear that no attempt should be made to reduce the contrasts in mental reactions merely to a discussion of differences between the respective brains and nervous systems.

In this connection it is important to note that investigations have led to a number of interesting hypotheses as to the probable origin of the sex differences, and some of these may have an important bearing upon the development of the adult qualities. For example, Whitman's theory that the male is the product of the stronger germ, in which the developmental processes are carried farther than in the case of the female,‡ merits careful consideration. The investigations of both Geoffrey Smith and Potts were among the first to give a clear demonstration of the changes taking place in the normal trends of activities when

\* Cotton, H. A., *Disturbances of the Internal Secretions*, edited by W. A. White and S. E. Jeliffe, vol. I, p. 469 (Lea & Febiger, New York, 1913).

† Hatai, S., "Growth of Organs in the Albino Rat as Affected by Gonadectomy," *J. Exper. Zool.*, 1915, XVIII, p. 1.

‡ Riddle, O., "The Theory of Sex as Stated in Terms of Results of Studies on Pigeons," *Science*, N. S., 1919, XLVI, July 6.

there has been any interference with the reproductive organs. The adaptive regulation of certain species of crabs was changed experimentally to such an extent following gonadectomy that latent female and feminine qualities developed in the male.\* But on account of the present uncertainty as to the interpretation to be placed on many of the findings, we are not yet justified in drawing any specific deductions as to the exact relation these findings have in the case of the human species.

The absolute weight of the brain in woman is from 120–150 g. less than in man, but when brain weights are compared with body weights woman's relatively is greater than man's. This does not signify greater functional capacity, for the brains of children are also greater in proportion to the body weight than those of the adult. It is also true that in proportion to the height the greater weight is in favor of man. In structure the brain of the female represents a somewhat simpler type than that of the male. But it should be said the careful comparison of the brains of the two sexes does not lead to any very definite conclusion as to the difference in functional capacity of these two organs. When the brains are considered in conjunction with the contrasts shown in other organs, then it is evident that the organization of activities in the two sexes shows considerable contrasts in all the different levels, particularly in those higher planes in which responses are naturally less stereotyped and more susceptible to influences coming from other organs.

Both the respiratory and circulatory systems in the two sexes present contrasts, but these will not be described at present, although they must have considerable significance in modifying both character and intelligence. The glands of internal secretion, as recent research results would lead us to expect, are important in relation to those traits that we have come to regard as specifically characteristic of the two sexes. The hypophysis, thyroid, thymus, and ad-

\* Smith, Geoffrey, "Studies in the Experimental Analysis of Sex," *Quart. J. Microscop. Sc.*, 1909–1913.

renals show much variation. When we consider the strong influence exerted by adrenalin in causing marked constriction of the blood-vessels, changes in the blood pressure, and quickening of the heart's action, we can understand how even slight variations in these organs may give rise to very great alterations in the emotional states which if constant may develop into permanent traits of character.

It is also supposed that the relatively large size of the thyroid gland in woman must have some effect in contributing to the different emotional states in the sexes. The fluctuations in its size during pregnancy and at the climacterium undoubtedly are of significance in relation to the emotional reactions at these periods.

The importance of the sympathetic nervous system in connection with the emotional life has already been insisted upon. This part of the mechanism of adjustment is controlled to some extent by the functional activity of the sexual glands. A good example of this in man is shown in the disturbance of their function following the excision of the testes. The subsequent re-establishment of lost parts relieves the depression and tends to restore normal activity.\*

Allusion has also been made to the great importance of the sex glands themselves in giving very decided trends to mental activities. The peculiar temperamental traits and characteristics dominant in eunuchs have been described by many writers. Their effeminate traits of character, the unwillingness to face critical situations, and consequent tendency to intrigue, as well as the frequent neuroses and signs of degeneration, are recognized symptoms. Despite a very prevalent opinion to the contrary, however, these qualities are not feminine characteristics, since they resemble much more nearly those of a third sex. Such phenomena are capable of interpretation in the light of the theory of the registration of mnemonic energies. The glands, because they are of undifferentiated origin, contain the energies of both

\* Wheelon, H., and Shipley, J., "Effects of Testicular Transplants upon Vaso-Motor Irritability," *Am. J. Physiol.*, 1916, XXXIX, p. 594.

sexes and the recall of one stimulates correlative characters while repressing those of the other. If castration stops the recall in these glands, there is an inhibition of the correlative characters and a state intermediate between the recollection of the healthy characters of the two sexes is established.

Recently so much attention has been directed to the part played by the sexual organs in the life of the individual, that it is as well to present some of the facts giving a clue as to the time when these specific functions begin to exert a controlling influence upon the general process of adjustment. Freud's theory that both sexual instincts and sexually determined behavior may be observed in the suckling infant is more a question of academic than of scientific interest, as the answer depends largely upon the limitations implied in the definition of sexual. Many of the responses into which a sexual meaning has been read by an enthusiastic observer and described as symptoms of auto-erotism are in all probability movements, induced by irritation from metabolic changes in muscles or nerves, or both, and which are followed by a group of muscular activities due to the linking together and co-ordination of reflexes by means of paths already existing for the conduction of impulses. The primitive responses of a babe cannot be described or interpreted in a phraseology that serves the occasion about as well as the clothes of the parent would fit the infant's body. In the Freudian use of the word "sexual" we have another illustration of the obstacles created for the psychologists when, with their minds occupied by concepts of consciousness derived from the study of the adult, they attempted to modify the ideas of the phenomena obtained from phylogeny or entogeny to meet the requirements already prescribed by an arbitrary definition. Investigators with some degree of familiarity with neural mechanisms and the development of the organs at this early period of life, can hardly seriously consider the polymorphous perversions described as then indicative of the possession of sexual characteristics. Many of the sexual traumata assigned to infancy are largely imaginative, at least in so far as to the time at which they are supposed



to occur. We have already noted the fact that such glands as the thyroid and adrenals are included in the neural circuit which regulates the embryo's life before the sex organs, testicles and ovaries, are in an advanced stage of differentiation.

In this connection we believe it is desirable to reaffirm what Watson has said, to the effect that the Freudian theory is not of great value in suggesting to the experimenter any of the lines along which the problem of the control of the emotional reactions may be accurately tested. Freud seems to have been too restricted in defining his point of view.

It does not fall within the scope of the present volume to treat of pathological conditions in detail; hence the racial or individual abnormalities in the incidence of the specific sexual functions may be passed by, and the occurrence of definite sexuality may be assigned to beginning at puberty. From this period the character of the individual is decidedly influenced by what is generally recognized as sexuality, through the influence exerted by the secretions of the respective sex glands, and in indirect consequence the entire emotional life; and therefore the intellect is shaped and somewhat controlled by these organs.

Although the immediate association of certain lines of activity is clearly demonstrable in connection with the more easily recognized forms of sexuality, the bonds between these are not so apparent. The sublimation of the sexual libido and the actual relations between the repressed instincts to activities in the religious, ethical, artistic, and general cultural spheres are, of course, easily proved. We cannot, however, subscribe to the views of those who believe in the almost universal inclusion of the functions of the body within the category of the sexual. But even when the domain is much restricted, as compared with that mapped out by the Freudian school, there remain a vast number of phenomena which may be included.

In women, the occurrence of puberty and the menopause is attended first by an increased and then a decreased activity of the ovaries. The accompanying changes in the emo-

tional and intellectual life at these periods furnish good illustrations of the establishment of certain predispositions as the result of organic changes. By reason of these distinctive organic differences, there are built up in the two sexes specific mechanisms apparent in the sentiments, feelings, volition, and behavior.

Periodic variations in the emotional tone occur at the menstrual periods. In studying these changes we should be careful to avoid the mistake of minimizing these fluctuations because we are unable to detect changes in the affective and intellectual life which cannot be detected by psychologic technique.

Quite recently attention has been called to the statement that in a careful study, conducted over a period of three years, of the mental activities of twenty-three women compared with two men, there was practically no loss of energy or acumen during the menstrual period.\* The tests applied were used to determine the voluntary speed of movement, steadiness, accuracy of perception, and controlled associations, and on the evidence obtained there seemed to be no reason for assuming the lowering of mental or motor efficiency at the time of menstruation. The methods used were evidently inadequate to solve a very large problem.

Judged as a purely biological problem the burden of proof falls upon those who affirm there are no marked differences between the male and female type. Without doubt there seem to be marked psychological deviations in all organisms where there is a distinct differentiation of the gametes. As Tansley† points out, the male gamete is often small, active, and extremely sensitive to the chemical stimuli of the female gamete, which is large, contains stored food, and is more or less passive. These two traits of activity and passivity are more or less characteristic of the psychological sexual differentiation that takes place during adult life, and is

\* Hollingsworth, L. S., *Functional Periodicity. An Experimental Study of the Mental and Motor Abilities of Women during Menstruation* (Teachers College, New York).

† Tansley, A. G., *The New Psychology in its Relation to Life* (Dodd, Mead & Co., 1920).

connected with the whole primary mentality distinguishing the two sexes. There are already too many facts available in regard to the periodicity of the waves in the affective life of woman during the menstrual flow to disregard them, and as the ebb and flow of the emotions condition the higher intellectual processes in the normal type of woman it is only reasonable to expect some variations in the mental equilibrium. Assuming that as the result of changes in social conditions these fluctuations do not exist, then it is reasonable to ask whether as the result of compensatory reactions many indefinite but annoying unsatisfied longings and symptoms of inadequacy have not been aroused in women by the repression of natural instincts and functions. There is also another point to be remembered, to the effect that even if changes demonstrable by psychologic technique are not present during the menstrual period the continuance of these habits would in all probability lead to anomalous emotional conditions which in turn would disturb both temperament and character.\*

It would be instructive to know more of the details of the sexual life of women who have taken a prominent part in public affairs. In the historic case of Jeanne d'Arc, who, we are told, never menstruated, there seems to be a definite correlation between the physiological trends and the temperamental and intellectual qualities. But we are not yet in a position to say definitely to what extent these close reciprocal relations between sexual functions and emotional and mental qualities hold true. The question should be studied from a broad biologic and not from an academic psychologic point of view.

The greater emotionalism of women as compared with man is well known. Feeling enters more directly into the expression of her activities as is indicated by the more rapid and marked changes in the reactions to emotional stimuli. Sensitiveness for pressure, taste, smell, and color is more pronounced in women than in men. Stored-up impressions not immediately within the field of consciousness appear,

\* Johnson, R. H., *School and Soc.*, 1917, V, p. 67.

moreover, to have greater dynamic power, often greatly limiting the activities of the conscious adjustments. On this account, as well as by reason of her greater sensitivity to impinging stimuli, woman is less inclined to be deliberate in thinking or acting and is more readily swayed by impulse.\*

Women also unquestionably show a greater capacity for responding quickly to environmental changes than men do; but, on the other hand, we should be careful in identifying this increased sensitivity with receptivity. The subject needs thorough study before the assumption can be justified that contrasts the qualities supposed to be specifically characteristic of the mental reactions of the two sexes, namely, the receptivity of women and the productivity of men. The former cling also to traditions and familiar surroundings with greater tenacity than do the latter; and despite the feminist arguments to the contrary this feminine trait seems to be an expression, not of an acquired characteristic but of a deeply rooted biologic trait. In the male sex we meet with a sense of recognition, definitely formulated, of the fact that life is a struggle for existence; and man's acceptance of this idea gives greater play to the desire to overcome opposition, to enter actively into contests, to formulate plans of campaign, to be the aggressor.

These inherent qualities of mind fortunately make it impossible for the normal man and woman to look at many of the practical and theoretical problems of life from the same point of view. This distinction is well brought out in studying the characteristic manner in which the two sexes repeat anecdotes and tales they have heard narrated. The healthy boy or girl, man or woman lives the part toward which each is unconsciously impelled by the underlying forces characterizing the sex.

The sexual influences are apparent in the usual forms of literary expression adopted by the two sexes. The influence of erotism is less active in boys at a relatively early period than it is in girls; and girls obviously are more

\* Ellis, H., *Studies in the Psychology of Sex* (F. A. Davis Co., Phila., 1906-1911. 6 vols.).

immediately influenced, when attempting to write, by traditional standards. In them we have a decidedly "emotional, dreaming, socialized trend," whereas in boys there is a "rational-satirical-logical-philosophical influence," and when these trends are associated with literary skill the youthful feminine aspirations generally tend toward romanticism in contrast to the dithyrambic sallies of the boy.\*

Because the emotional reactions are largely dominated by subconscious mechanisms women are more likely than men to be guided by first impressions, and therefore are usually very susceptible to unreasoning likes and dislikes, for persons and things. It is equally true that such first impressions are more often found to be correct than are those of men. Then too, by reason of this degree of impressionability, the limits of the fields of consciousness are rather narrower in women, which restrictions may possibly account for the fact that their interest in the concrete is more developed than in the abstract; hence the tendency to form broad generalizations and to follow logical trains of thought are seldom dominant characteristics of the female mind.†

With this emotional sensitivity an active imagination is quite in accord. But as regards memory there seems to be no striking sexual difference, although, prior to the onset of puberty, for both sexes there seems to be a rapid rise of this function, which thereafter becomes more or less stable. It is quite understandable that an analysis of all these functions that contribute so much to the personality is necessary in any estimate of the so-called intellectual traits.

An interesting study as to the relation of quickness of learning to retentiveness gives evidence that girls and women in their initial efforts at learning a new subject do better than boys and men. The retentiveness of the latter, however, seems slightly better than that of the former. As a matter of fact we should not look for any great differences in studying single functions. It is rather the number

\* Giese, F., *Arch. f. Pädagogik.*, 1913, II, p. 44.

† Buecera, C. J., *Geschlechtsunterschiede beim Menschen* (A. Holder, Wien u. Leipzig, 1913).

of small differences making up the general ensemble of reactions considered collectively that give the characteristic stamp to the male and female personality.\*

The mechanisms concerned in the act of recollection, however, are quite unlike in the two sexes because of the prevailing differences in the emotional life; but the specific qualities leading to the contrasts have not yet been determined. At present we only know that the emotional reactions seem to increase the intensity with which certain impressions are stamped and to make more vivid the act of recall.

The variations in the characteristic traits of the two sexes are frequently to be sensed rather than to be defined with precision. It is very generally recognized, for example, that man is more egoistic and less altruistic than woman. But here again we must qualify the statement, since that which at first seems to be a marked contrast, careful study has shown to be more a complementary and less an opposing quality.

In voluntary acts mechanisms of a similar kind are noted. The apparent feminine weakness is often the result of stronger impulses the effect of which is sometimes remarked in connection with the sense of veracity. In woman the quality is sometimes developed to a high degree in certain directions and is deficient in others. Such conditions are doubtless, in a measure, the result of the freer play of impulses and the more active imagination. A woman who under some circumstances may appear weak and irresolute, may in the face of a great crisis display a heroic power of self-control and an extraordinary ability for acting intelligently.

Although these natural instincts and customary forms of reactions in men and women present such definite contrasts, it would be ridiculous to interpret them as indications of higher or lower forms of adaptation; biologically considered they are complementary. The perpetuation of the species

\* Lyons, D. O., "The Relation of Quickness of Learning to Retentiveness," *Arch. Psychol.*, 1916, XXIV, no. 3.

depends upon the preservation of the qualities of both sexes; and signs of intellectual and physical decadence will doubtless correspond with the increase in the number of people with neutral sex qualities. Because man has loudly proclaimed faith in his own sufficiency and woman has often doubted her possession of it, is no reason to glorify the masculine virtues and to detract from the importance of the sphere occupied by woman.

Jastrow (*opus cit.*) has given a general survey of what he believes to be the distinguishing traits of men and women. We question, however, whether his reference to the "greater normality of woman, bringing her nearer to the child-type and to the race-norm" as the result of her anabolic habit, is the correct interpretation of her position in the biologic scale. If it should prove a correct theory, then only children would represent the normal types. There is no more reason to adopt an apologetic tone in discussing the temperamental traits and the characteristics of woman than there is to assume a plane of greater superiority for man.

Experience tells us that the enthusiasms of women are as a rule more spontaneous and less conventionalized than are those of men. The feminine inclination to worship the qualities of one person is marked, as well as the enthusiasm for exhibiting a remarkable devotion to some single cause. Although these conditions prevail, it is also true that women are more passive than men, and this trait is particularly well marked in connection with the primitive sexual instincts. The effect of civilization upon these trends has been to give rise to a process of sublimation and refining of instinctive activities which stir up subconscious responses possessing great driving power. One of the greatest follies of our present social system is to repress the sentimental qualities in women which are the direct expression of deep-seated instinctive forces, and the preservation of which would go a long way in protecting human life from the weary, monotonous, and bungling efforts of neurotic reformers in their attempt to disregard the question of natural dispositions and psychic suitability in judging what the

sphere for woman should be. It would seem the part of wisdom to make the best use of the biologic differences as existing in the two sexes, and neither to yield to prejudice by ignoring the distinctions, nor, having acknowledged them, to endeavor to improve on Nature by repressing the normal sexual trends with the purpose of producing a race characterized by nauseous mediocrity of traits. Woman, it has been well said, has a greater integrating as distinct from man's superior differentiating capacity,\* marked by greater patience, open-mindedness, and more delicate appreciation of details in contrast with the masculine broader scientific insight and a greater capacity for making generalizations.

With these essential biologic facts in mind, it is clear that if our system of education is to take an active part in cultivating, not repressing, the physical and mental qualities essential for both leadership and co-operation, we must sooner or later take measures to preserve and strengthen the normal sex qualities.† Nor can we afford to continue to disregard them merely because the efforts to obtain political equality have dictated a policy inclined to ignore fundamental distinctions. The present method of insisting upon the coeducation of boys and girls, particularly during the high school and college years, gives abundant opportunity to observe the sacrifice of sterling normal propensities, the possession of which is of incalculable value for the preservation of positive dominant qualities of mind and body, to what may possibly be a more refined but is surely a less effective product bearing many of the signs of hybridization.

Data already at hand show that, if sex instincts, the great normal heritage of men and women, are heedlessly ignored, and natural dispositions repressed, serious dissociation of the personality is the result. Phases of that discussion, which is so inherently a biologic question, have been confused with narrow political issues in a most unfortunate

\* Geddes, P., and Thompson, J. A., *Sex*, Home Univ. Library, 1914.

† Mosher, Clelia D., *Health and the Woman Movement* (The Woman's Press, New York, 1918).



manner. What amount to expressions of inadequacy by many neurotic women are cited as arguments favorable to granting political equality with men.\* The neurotic, both man and woman, who are seldom certain of an established equilibrium, constantly insists upon attaining imaginary "rights," which, by reason of their very illusiveness and inattainability, prove extremely harassing. But care should be taken to distinguish between those women with an intelligent definite wish to attain political equality, and those with ill-defined longings that are merely the expression of imperfect adjustment. France, a country that has perhaps been less prominently identified with efforts "to emancipate women" than any other of the nations leading in civilization, has in these years of trial given a magnificent demonstration of the advisability of cultivating manly and womanly qualities without sacrifice of the normal sexual traits of temperament and character. That which we have been accustomed to describe as the superficial charm and grace of the French woman has proved an invaluable aid in favoring the growth of the sterling qualities forming the first line of defense both of French homes and democratic institutions. The present tendency in this country to underestimate the need of cultivating in young women these feminine traits has already resulted in an insidiously dangerous form of egotism and has given ground for belief that a change in public opinion as to the position women should occupy not in public but in the home is inevitable if we are not to suffer retrogression.†

Comparison of all facts relating to this subject justifies the inference that large numbers of infantile asthenics found among women are not products of education, nor the result of work unsuited to their abilities, but show the

\* Wright, Sir Almroth F., *The Unexpurgated Case against Woman Suffrage* (Paul B. Hoeber, New York, 1913).

† Lavedan, H., *La famille française*, p. 24 (Perrin & Cie., Paris, 1917). "Les femmes qui veulent être mères, qui sont heureuses de la venir et souffrantes d'être privées, forment une minorité que les amazons de mariage et les émancipées du devoir maternel affectent de considérer une catégorie de natures grossières ou malades, imbuées de l'esprit des vieux âges."

effect of influences to be attributed to defects of congenital origin; in other words, the weakness is largely an inheritance.

Our task in education is therefore to direct primary inclinations along lines that will facilitate, not hamper, the attempts made by each person toward successful adjustment of life. To accomplish this it is of first importance to determine what the original or primary trends are; otherwise, the educational process is likely to defeat the very ends it is intended to serve. The success of any reform movement in education depends largely upon the recognition of the distinction between primary and secondary trends, so that the vital activities may be directed into channels that will strengthen rather than dissipate the nervous energy in our struggle for existence.

As our knowledge in regard to the functions of the various organs is increased, it will become possible to trace out the origin of many of the trends of activity to their source. But at present we must often wait until disease or imperfect development has analyzed functions sufficiently both to make clear their interrelationships and to open a way for tracing still further the genesis of more complex activities. Attention has recently been directed to a large number of cases in which the advantage of the biologic analyses are evident. Here is one example. There is a well-recognized group of persons "who, having attained or passed the years of puberty, retain many of the morphological characteristics of infancy; and the retarded physical development may be readily correlated with the imperfect mentality." These people have never grown up. Inasmuch as it is possible to trace an intimate dependence between the imperfect physical state and the anomalies in the emotional and intellectual processes, such cases are of interest both to the clinician and to the student of human behavior.

Years ago, as far back as 1836, Andral, a French physician, was greatly impressed by the close relationship between the physical deterioration produced by disease later known as tuberculosis and the general inhibition of all the growth

processes of brain and body. Another Frenchman, Lasègue, in 1871 observed that the evidences of infantile traits were to be found in another group of cases termed *infantilismus*. In such instances of so-called asthenic infantilism, or infantile asthenia, there are strong indications of the absence or reduction of the potency of the factors usually determining the primary and secondary trends that give force and set to the current of activities.

The more direct and immediate causes that in the struggle for existence serve to expose the persistence of infantile traits have been designated as follows:\*

- (1) Social factors—causes incident to home and general social life of the person.
- (2) Biologic factors—age and sex.
- (3) Psychologic factors—menstruation, puerperium (pregnancy).
- (4) Psychologic reactions—emotional storms.
- (5) Physical agencies—meteorologic, traumatic.
- (6) Pathologic causes—intoxications, infections, chronic diseases.

We cannot here enumerate the many pathologic conditions possible in the various organs or speculate upon their relative importance either as primary or contributing causes. But infantilism furnishes a striking example of the intimate dependence of temperament and personal traits of character upon the functional efficiency of various internal organs.† In the persistence of infantile skeletal characteristics, in anomalies of the sexual organs, or of the vascular or lymphatic systems, in disordered functional activity of the glands of internal secretion, as well as in other disturbances, we have instances of this condition. Attention has lately been called to the sinking down and forward of the internal viscera as demonstrating a physiological inferiority, since these conditions are attended by alterations in the emotional and intellectual qualities. The

\* Du Bois, P., *Die Psychoneuronen u. deren Behandlung* (Francke & Co., Bern, 1904). *The Education of Self*, trans. by E. G. Richards (Funk & Wagnalls Co., N. Y., 1914).

† Mathes, P., *Der Infantilismus, die Asthenie* (S. Karger, Berlin, 1912). Piéron, H., "Le Puérilisme," *Rev. d. médecine*, 1919, no. 3.

slouchy postural habits so common in this country are a fairly sure indication of sloppy mental processes and the absence of clear-cut, forceful reasoning ability. "The relation," writes Miss Bancroft,\* "of posture to intelligence and brain-power is marked and of great interest." The shifting or lowering in the abdominal cavity of one or two organs may lead to disturbances in the chest, so that the activity of the heart and lungs is interfered with. Although habit undoubtedly accentuates the malposition of viscera, the primary trouble is probably due to the inferiority of the tissues themselves, which permits the organs to sag. In women disturbances of the position of the internal organs are sometimes attended by changes in the position of the sexual organs, associated with symptoms indicating functional derangement of the nervous system. In infants and young children there are often definite disorders of digestion which are not the cause, but the product, of inferiority.

Emotional disorders are among the commonest signs of physical inferiority; and these are often represented by rapid changes in moods. The cases with pronounced indications of emotional disorder often come, as a matter of course, under the observation of the physician or specialist, but there are numbers of others that practically never receive medical attention. In those instances in which the emotional trouble is not considered as pathological, there is often much incoördination between the ideas in consciousness and the synchronous reactions. The suggestion has been made that whenever an event, which under normal conditions should leave an impression calculated to arouse serious thought or sadness, fails to counteract the persistent elation, this state of mind may be considered as hyperthymic, in contrast to the antithetic dysthymic condition, often apparent when amusing or entertaining ideas fail to counteract the mental depression.

The importance of the emotional anomalies merits em-

\* Bancroft, J. H., *The Posture of School Children* (The Macmillan Co., N. Y., 1913).

phasia, because they occur so frequently in children; and upon their early recognition depends the chief hope of correcting them and of inhibiting trends responsible for the undesirable activities. In addition to the states of exhilaration and depression, other anomalous forms of response may be mentioned. A general apathy and indifference to any higher kinds of interest are often noted. Associated with this, various changes in the organic sensations may occur. These lead to a deficiency or loss of the sense of reality, and at times result in periods of intense anxiety. The excellent description given by Mathes, of the mental states in cases of infantilism, demonstrates how important is the recognition of such conditions by parents and teachers, in order that a type of education suitable to the individual's needs should be adopted. The "infantile type" is met with in all classes of society, and, although the symptoms vary greatly according to the exigencies of adaptation, the fundamental mechanisms giving rise to such disorders remain unchanged. And unquestionably many of the stigmata of infantilism are apparent in the conditions often described as psychasthenia, neurasthenia, and hysteria.

It is probably the sympathetic nervous system that is involved in the production of almost countless numbers of the symptoms evident in such cases. This system furnishes the connecting links between many organs and serves to unify and harmonize their functions. Our estimate of the importance of the nervous processes, as depending upon their representation in consciousness, is likely to interfere with a true estimate of the importance of the sympathetic and autonomic systems, which are concerned in a greater number of reactions than those falling within the field of consciousness.

Moreover, the association between the symptoms in the higher planes of adjustment and the defects in the internal organs enables us to trace out their intimate relationship with the brain. The cerebral cortex, the new brain or ne-encephalon, represents an organ which, on account of its comparatively late development in the animal series,

is one of the more unstable mechanisms of *homo sapiens*. Under the strain imposed by the artificial conditions of modern civilization, it is hardly surprising that often the first sign of inadequate adjustment is the appearance of symptoms in connection with these higher brain centres. The more the person in daily life is forced into active competition, the more evident does it become that primary trends accompanying normal growth either become blended or are completely repressed, while a host of secondary defense mechanisms begins to take their place.

This confusion is apparent when, for example, we try to determine the underlying trends responsible for the temperamental and mental qualities characteristic of the white as distinct from the negro race. At the present time we are quite unable to trace the roots of the emotional and volitional life and to designate the basis for the apparent racial distinctions.

On a close analysis, the functional differences show certain contrasts, but no one suggesting specificity. It seems to be true that the mental efficiency of the negro is at least one-fourth less than that of the white man. Even when we make allowances for the fact that the groups of individuals studied are not altogether typical of the white and colored population, the general principle still holds true that the mental capacity of the white race is considerably greater. The negro has a greater emotionality, and as a rule less stability of character, but in the adjustments taking place in the lower planes, reflex and automatic, there does not seem to be any recognized difference between the two races. The sharp contrasts in the trend of activities are also revealed in the greater capacity of the white man to begin and carry through an abstract line of thought; a power which in the negro is relatively much more limited.\*

Although it is probable that these functional differences measurably depend upon structural conditions existing in the central nervous system, the influence of other organs

\* Cf. Ferguson, G. O., "Psychology of the Negro," *Arch. Psychol.*, April, 1916, no. 36.

should be taken into account. The relatively greater simplicity of the brain of the negro as compared with that of the highly intelligent white man, is doubtless one factor responsible for the more primitive qualities possessed by the former. There are, however, certain differences in temperament and character, which cannot be accounted for by gross anatomical differences in structure. It is not at all improbable that the blood and organs of internal secretion in a measure may be responsible for the physiologic basis from which distinctive temperamental qualities are derived.\* The analysis, in order to be complete, should take into account many different factors. We know, for example, that in the mulatto, where the intelligence is greater than it is in the pure black race, there is also a greater tendency toward immorality and the commission of criminal acts. This condition is probably the result of a recognized increase in mental ability accompanied by resentment at the position of social inferiority into which the mulatto is forced. It is also true that the sterling qualities necessary in courageously facing critical situations deteriorate when there is an admixture of negro blood.

\* Brown, Langdon, "The Sympathetic Nervous System in Disease," *Oxford Medical Publications*, 1920.

## CHAPTER IX

### HABIT-FORMATION

IN readjusting to meet difficult or critical situations every human being depends first of all upon instinctive methods of response, or if these are not sufficient then the impulses are elaborated by emotion. Often, however, in order to effect a readjustment, "habits"—integrated reactions, modified and improved by repetition and experience are formed.

The word "habit" is generally used to designate certain forms of adjustment marked by increased facility in execution due to repetition, and includes responses in which the motor element in the reaction is usually only dimly represented in the field of consciousness. Habits may also be described as individual adaptations, or modifications in behavior due to experience, and accompanied by merely slight, if any, participation of consciousness, which only becomes a prominent factor in the cerebral processes when a choice between two or more motives is required as preliminary to action.\* In instinctive reactions the pattern and order of the reactions are inherited, whereas in habit they are shaped by experience and are acquired.†

In analyzing habits certain factors stand out very clearly. It is obvious that, when living beings are stimulated, their responses show certain dispositions or aptitudes characteristic of the individual; and these reactions, provided the conscious factor is not a prominent one, we are accustomed to designate as habits. In a certain sense "habit" and "disposition" may be considered as synonymous. Some persons do not consider actions taking place solely in the reflex level as habits, and look upon the introduction of the instinctive element, whatever that may be, as the

\* Bagley, W. C., *The Educative Process* (The Macmillan Co., N. Y., 1910).

† Watson, J. B., *Psychology* (J. B. Lippincott Co., Philadelphia, 1920).



distinguishing criterion. A definition made upon this basis sanctions the view that habits may be described as the unconscious or semiconscious adaptations of organisms, repeated often enough to become characteristic of their responses. It is perhaps better not to insist upon any rigid system of classification in order to avoid the implication that the behavior of organisms is capable of being analyzed upon a basis of specific differences.

Habits are settled tendencies or characteristic manners of adaptation exhibited by living organisms in the environment in which they exist. Habits represent, in the higher organisms, something more than mere reflex activity, because they are adjustments modified and shaped by instinct.

It is unnecessary to emphasize the importance of habits in facilitating successful adjustment. The current phrase "creatures of habit" has, in addition to its popular significance, a biological one. If, as has been stated, "one-third of our mental make-up is instinct, one-third habit, and one-third a process of becoming one or the other," we shall readily understand the importance of analyzing the mechanism of habit-formation. The ordinary definitions of habit, that are commonly accepted, predicate a peculiar aptitude, a settled disposition, or a tendency to a particular action or effect. But the physiologic conditions actually determining the nature of the forces giving the set to the currents, are not yet well understood.

In the higher animals habits depend upon the existence of paths of "preferred conduction" in the nervous system along which impinging stimuli travel and are conveyed to centres where they are elaborated, modified, and discharged as impulses.\* The previous experiences, the experience continuum, of the organism enter largely into these modifications. The tendency to react in definite ways, or to form channels by which energy is discharged, depends upon the structure as well as upon the physical constitution of living matter. Although the structure of an organism is undoubt-

\* Colvin, S. S., *The Learning Process* (The Macmillan Co., N. Y., 1913).

edly one of the principal elements in determining the genesis of habits, the nature of the underlying chemical changes taking place associated with the vital processes is also of primary significance. Some of the chemical changes in inorganic substances remotely suggest the occurrence of the formation of habitual types of responses similar to those in living organisms. If, for example, certain solutions are placed in shallow dishes and allowed to stand until crystals have formed, and the liquid is then stirred before again being allowed to settle, crystals will form exactly at the same points on the surface of the fluid.

The fact of the general relationship in the lower organisms between structure and habit is so well known that there need be no special emphasis placed upon this subject. Even zoospores, or the sexual cells of algæ respond with such remarkable rapidity to stimulation that this type of reaction is characteristic of their structure and chemical construction. There is almost no latent period between the incidence of the stimulus and the immediate response in the form of swimming movements. On the other hand, plants when stimulated usually exhibit a period of delay before the reaction is apparent. A plant when exposed to sunlight may hold its upright position for some time before bending its head toward the source of the light. Here structure and function again determine difference in response. In the plant world we see wonderful evidences of modifications in habits which are probably the result of changes in both elements. In *linaria cymbalaria*, a plant generally attached to walls, the twigs bearing flowers turn in the direction of the light until fertilized, when, as the result of internal changes, an inversion of movement follows.\* Many similar examples in the animal world could be cited. Thus the jellyfish has a definite habit of swimming due to structural and physical qualities. By repetition of acts increased facility of performance and decreased resistance for transmission of stimuli are ordinarily gained, and

\* Acqua, C., "Esistono fenomeni psicologici nei vegetali," *Scientia*, 1914, XV, p. 187.

these two factors may be said to form the physiological basis for habit-formation.

Both these phenomena may be observed to advantage in the life of the vertebrate embryo. The first slow movements of the body become accentuated and rapidly gather strength and precision, due unquestionably to the associated changes taking place in the tissues. Gradually a period characterized by the occurrence of unconditioned reflexes is succeeded by one in which environmental conditions become more and more important factors modifying the responses until definite conditioned reflexes are developed, when the period of habit-formation begins. The appearance of this second stage is illustrated by the manner in which incident stimuli commence to take effect. We called attention a number of years ago to the fact that the first motor habits of the embryo, prior to the differentiation of the sensory and motor nerves, are not affected by such drugs as cocaine, for only when the organism has more points of contact by means of a well-developed nervous system do the primitive, unconditioned forms of adjustment become capable of being modified by the action of local anæsthetics. In these relatively simple forms of responses we may trace the growth of the mechanisms which make possible the habitual reactions of the adult.

Age is of course a very prominent factor in the formation of habit-mechanisms. This is due not only to changes taking place within the nervous system, but indirectly to the alterations in the functions of various internal organs. If we try to draw an analogy between the "learning ability" in rats and human beings, it is evident that there are inferences deducible from experiments made upon the rodents which are suggestive for those who are interested in the study of man. Old rats seem to solve new problems as quickly as the young ones, but the actual retention-ability of the memory still needs to be tested before a decision can be reached as to whether the "relearning" requires more effort on the part of the former than the latter.\* When

\* Hubert, Helen B., "The Effect of Age on Habit Formation in the Albino Rat," *Behavior Monographs*, 1915, II, no. 6.

this point is cleared up, it may be possible to formulate a general law that will be applicable to all the mammals and will throw considerable light upon some of the fundamental questions connected with habit-formation.

The striking rhythmic character of many of the responses of the lower organisms and of the earlier stages of functional activity of the higher animals may also be noted in the reactions of adult human beings; and this rhythm marks the conscious adaptations. Associated with the phenomena of menstruation there is a certain rhythm or cycle marked in various activities and indicated by the curves in the pulse-rate and rise and fall of the body temperature.\* The highest point is reached several days prior to the onset of the menses, and the lowest on the third day after their cessation. A corresponding fluctuation also takes place in the emotional life.

Periodic rhythmic fluctuations occur in the life of both men and women, but in each sex the higher the degree of organization of the nervous system the more does the appearance of the periodicity tend to become hidden by compensatory mechanisms. Frequently the person recognizing the period of ebb makes an effort to compensate for the regressive stages. The physiological rhythm characterizing all the activities is sometimes indicated either in the temperament or in moods when, on the one hand, an individual "feels fit" or, on the other hand, "not up to work."

"Neither mental nor physical development," says Bagley,† "follows the law of uniformly accelerated motion." These "waves" must be taken into account in planning for any formal discipline. In them there are all degrees of variation, ranging from the ordinary ups and downs of the daily life of the normal person to the more pronounced fluctuations of a pathological character, of which the milder cases are designated cyclothemia. These rises and falls undoubtedly play a very important part in the development of habits. The subject of the fluctuations constantly

\* King, Jessie L., *Am. J. Phys.*, 1914, XXXIV, no. II.

† *Opus cit.*

taking place in the mental life will be considered in connection with the phenomena of dissociation.

In normal cases the analysis of habits frequently becomes so difficult that we have often to wait until disease has either rendered a complicated process simpler or thrown its constituents into such opposition as to permit of ready detection of its various links. This principle holds true for the study of habits that are more directly the out-growth of affective states. The process of perception is accompanied by a distinct feeling-tone, and under normal conditions there is a complete blending of the representation in the mind and the accompanying feeling. In this instance the synthesis or integration is complete, and harmony is the result. Under other conditions, however, there is an opposition established and then the incident stimulus gives rise to a contrary feeling; so that ambivalence, and not constancy, marks the entire reaction. The relationship of the representation, or the idea, and the associated feeling is a very important factor in habit-formation, and may be disturbed either by some physiologic incident of consequence or by the struggle between impulses as to which one shall dominate in directing the activities. We know how common it is that sights and sounds which in normal circumstances give rise to pleasurable sensations, in diseased conditions stir up contrary feelings. In other cases, we frequently observe that there is an abnormal persistence of a feeling-tone in spite of the change in external conditions which gave rise to it. This often involves not only simple sensations but in a psychosis it may be extended so as to include complicated sentiments and intellectual dispositions. In pathologic states the "contrary feeling" is repeatedly noted in relation to the association of the sexual impulses.

The excessive dominance of one feeling-tone is often responsible for a set of habits quite different when compared with that initiated during a contrasted state. In moods of depression the reactions are apt to be modified to varying degrees. Responses often take place with difficulty due to the psycho-motor retardation. This is in marked con-

trast to the hyperactivity of a period of expansion characterized by the steady flow of talk, ideas, and other activities. In many individuals there is a mixture of the two states—depression alternating with exhilaration and general excitability, the two sets of habits standing in sharp contrast to each other.

A French physician, Falret, years ago described cases in which very mild periods of depression, both physical and mental, were associated with states of expansiveness and exhilaration. All grades were represented from persons capable of performing the ordinary duties of life with a fair amount of success to those who were more or less handicapped during the persistence of the affective disease. Such symptoms of depression vary considerably. There may be simply a general gloomy, heavy sense of oppression, when sensations of an unpleasant nature seem to be accentuated, being accompanied by a shrinkage of the "ego," so that the individual becomes unduly apologetic for personal shortcomings and assumes the attitude of unworthiness or inadequacy. The emotional life, except for disagreeable stimuli, is restricted, and the person may complain of his or her spirit of apathy. On the one side of the balance there is an evident psychic anæsthesia and on the other a marked condition of hyperæsthesia.

Sometimes, instead of the merely passive state of depression, there is a condition of anxiety without any definite association of ideas. The habits of the depressed state stand out in sharp contrast to those of the period of elation; and some of the principal mechanisms should be carefully noted, since they are useful in aiding us to understand more about the building up of a series of habitual reactions of a definite type giving the specific mark to character. The habits more or less characteristic of these two contrasting states are evidently expressions of very deeply seated organic changes.

The sense of depression may be accompanied by an abnormal sense of effort, so that all activities both mental and physical are attended by a subjective feeling of in-

creased difficulty in achievement. Even simple muscular movements require a greater expenditure of energy to overcome the initial passive resistance. There seems to be a lowering of the psycho-motor irritability; at least, reasoning by analogy from pronounced types of cases, this condition may be inferred, although examination with the methods now in clinical use fails to reveal any positive changes in the nervous end-organs for picking up and transmitting stimuli. Observations, however, do indicate that even in individuals with marked retardation of response, an incident stimulus may tend to set loose quite rapidly a series of unpleasant and often painful impressions.

Very occasionally, in contrast to this state of depression, there is another one marked by exhilaration. Here, instead of a slowing down and lengthening of the duration of the processes, there is a decided excitability, noticeable in the quick flow of ideas, increased volubility, and general restlessness. Within a few hours the person's habits may undergo an almost miraculous transformation. The ensemble has completely changed. With the hyperactivity there is apparently an increase in the number of nervous explosions that give rise to movements. The flow of activities is seemingly largely purposeless, or at least there is no guiding permanent motive exercising a dominant control. The verbal mania, the constant hurry-scurry without definite achievement, and the disconnected train of thought may all be regarded as habits formed in response to the incident stimuli of general excitability. In this case it is very evident that the controlling factors are the emotional reactions, and these give rise to a set of conditions which are the sources of the actual directing forces underlying the habits. In this group of cases the great rapidity with which sets of habits may change, on account of the complete turn-over in the emotional life, is strikingly illustrated.

In order to grasp the full biological significance of habits it is essential that they should not, as is so often the case, be considered merely as isolated phenomena. Habit implies association and a fusion of many elements. Habits

also give some idea of the individual's synthesizing capacity, and, as Yerkes\* affirms, habit, instinct, and association are revealed expressions of one fundamental organic principle, *i. e.*, that of unity.

Good habits are an expression of organic unity; that is to say, they measure the individual's ability to direct his activities toward some definite end and form biologic syntheses. Habits should not be considered merely as local phenomena. They are intimately related to the general activity of the organism. In the reactions marking the occurrence of mental diseases the more primitive habits of the organism have a great influence upon all the various forms of adjustments. The special forms of expression registered by certain habits are merely indications of the general activity. Thus the tenacity with which certain ideas persist in consciousness, resulting in a gloomy, depressed mood, depend upon fundamental qualities. The duration and pertinacity of the reactions are indications of an increased sensitivity and an exaggerated facility in recalling impressions. No matter on which level of adjustment habits are formed, their foundation is upon the same basic mechanisms. The mental activity is merely another phase of the general activity. In the mass of our feelings and ideas the automatic processes—habits—involved in the acts of recollection are far more numerous than those concerned in the invention and presentation of new material for either feelings or thoughts.†

The power of recall, forming such an important part of the habit-mechanism in the great majority of instances, is not associated with consciousness. We often assume that the conscious element in a reaction supplies the drive responsible for the continuation of the process, but this is really not the case, as it is the product chiefly of automatic responses common to all living organisms. The processes described as mechanistic in physiology are as Leclerc re-

\* *Opus cit.*

† Leclerc, A., "Habitudes et troubles mentaux," *Rev. philosoph.*, Sept.-Oct., 1919, nos. 9-10.



minds us, identical in large measure with those referred to as individual and specific.

Stimuli acting simultaneously within an organism give rise to a state of irritability which we may assume stamps an impression upon the protoplasm forming a synthesized uniform imprint. The tendency to reproduce any mechanism or series of mechanisms demands the recall of at least part of the conditions (experience continuum) which originally produced them. The associations essential for the development of habits represent the links of the complex. Habits grow not only because movements recur, but because they depend to a great extent upon the results of other acts; those with a tendency usually favorable to the organism are repeated, while the useless parts of the mechanism are dropped. The ease with which useless movements disappear depends upon a number of circumstances, the details of which cannot be given here. How familiar is the sight of a child learning to write! Not only do the fingers move, but legs, head, and tongue often perform associated movements. Compare the co-ordinated simplified motions of the expert tennis-player with the wasteful expenditure of energy by the novice.

That which is true in respect to lower planes of activity also holds good for higher ones. Gradually in the learning process the useless movements are given up. It is not always easy to decide upon the extent to which it is desirable to attempt to facilitate the art of learning by forcibly inhibiting the superfluous movements. Sometimes the stream of attention in a child may be strengthened by admonishing him to sit quietly, not to stick out his tongue, etc. But at other times excessive interference serves only to increase the distractibility and decreases the learning capacity. In such cases it is far better to suspend the process entirely, and to wait until, after a period of protracted rest, the necessary elimination takes place automatically. There are educators who go so far as to advocate a complete non-restraint system during the period when the child is being instructed, but this is not advisable because the con-

stant repetition of purposeless movement, particularly in states of fatigue, often tends to crystallize bad habits so that the child becomes incorrigible. Since neurotic children chafe under restraint, the plea is often made for the abolition of the ordinary measures used to preserve discipline in classes, a plea that demonstrates the great prevalence of functional nervous disorders. Discipline for normal children, if intelligently directed, is always useful in habit-formation.

The reduction of many processes to the level of automatic activity is of great value to the organism. This reduction is one of the chief characteristics of the learning process. We find this true in regard to the physiological processes, and from the study of disease we get a definite idea of the enormous saving of both time and energy, when many adaptations occurring in the higher levels are rapidly and successfully reduced to the lower. Patients during an illness often find it very difficult to execute even simple movements or adaptations. The co-ordinating and adjusting capacity of the nervous system may be interfered with to such a degree that there is practically little or no direction of activities toward a common end. The invalids seem to be deprived temporarily of the capacity to serve any definite purpose, and their movements and other activities have the appearance of being more or less purposeless.

Various attempts have been made to classify habits, but when we consider the reactions as expressions of the capacity of the entire organism to adjust its activities to meet the demands made by environment, then a division upon a neurological basis or any division representing a single phase of the problem can have only limited value. For convenience of description, however, we may accept a classification that distinguishes between the reactions following immediately upon excitation, as when the sight of the pen arouses the chain of responses resulting in writing—sensori-motor type—and those following the elaboration of some inner impulse giving rise to an ideo-motor type of reaction.\*

\* Stout, G. F., *Analytic Psychology*, vol. II, p. 88 (Cambridge, at the University Press, 1919).

Frequently we see cases in which activities which should be carried on at higher planes seem to be forced down to the automatic level; accompanied generally by some evidence of the reduction of higher centres and the abnormal dominance of lower functions. In such instances, when purpose and end are lost sight of, the mechanisms are quite different from those first described. Not only do the movements taking place in what would under normal conditions be called the voluntary level resemble those of an automaton, but the rigidity and loss of plasticity are also noticeable in connection with the intellectual processes. Persons in this condition may declare that they feel that "thinking goes on" inside their own heads without any reference to their wishes and quite unrelated to other activities. Automatisms of speech are not rare: words are uttered because "they are actually placed on the tip of the tongue."

In such cases there is an abnormal tendency for representations or ideas to persevere in consciousness, and the primary relationship between intensity and the quality of perception is impaired. Exaggerated perseverance is very marked in fatigue as well as in so-called schizophrenic states. The repetition of parts of words, portions of sentences, ill-defined ideas, senseless sounds, and bizarre mannerisms often bears testimony to the stubborn persistence of the habit-mechanism which gives expression to them. There are various forms of automatism occurring in these states which are foreshadowed in many of the acts of those not afflicted with a definite neurosis or psychosis. In one instance acts may be performed under a stronger compulsion than is ordinarily the case, and the person performing the act is at a loss for a motive. In more exaggerated cases there is a definite sense of compulsion, and this compelling force may be associated with an imaginary command or duty to act. Occasionally there is such a complete dissociation of the personality that the part of the body concerned in the act is supposed to possess independent automatism; and the hand or foot may perform certain acts of which the possessor does not approve.

In contrast to automatism we may now consider the extent to which the activities of a person are capable of being modified, directly in response to environmental stimuli. Wheeler,\* has emphasized this point by demonstrating the manner in which the reflexes and instincts, as well as the plastic behavior of animals, all gain in precision with repetitions.

If, as has already been said, we observe carefully the changes taking place during the early stages of vertebrate development, we are likely to acquire a clearer notion of the manner in which the instinctive responses are built up and modified. From investigations of this sort we shall also learn how numerous are the conditions to be considered in shaping the responses of any organism to meet the changes in environment. In this respect, however, we have not yet been sufficiently influenced by the lessons taught by comparative physiology; for example, what we know in regard to the lower animals emphasizes that the character of the receptors for the stimuli must be taken into account. Many insects have the habit of responding to sound stimuli that we cannot sense; and doubtless fish measure pressure differences in their environment which we are not capable of sensing.

Environmental changes influencing habit-formation include those of a physical or chemical nature. Loeb has shown that if daphnia are placed in an aquarium, one side of which is exposed to the light, only part of the organisms go toward the light until carbonic gas is added, when all promptly become light-seekers. Following this same line of investigation, others have brought out the fact that daphnia actually have a distinct color sense. If these same organisms are placed in jars and subjected to moderate illumination, they seek the light or are positively phototactic, whereas increased brilliancy causes them to react negatively or to retreat to more sheltered parts of the jar. Positive

\* Wheeler, W. M., *Ants, Their Structure, Development and Behavior* (Columbia Univ. Press, N. Y., 1910).

reactions follow the incidence of all rays from yellow to the *b*-line of the solar spectrum, in contrast to the negative reactions evoked by blue-green, blue, and violet.

As we ascend in the scale of animal life, it is obvious that the influence of sense-perceptions in effecting crystallization of reactions into habits is a very considerable factor. Johnson\* discovered that some of the habitual responses in the dog, quite contrary to what would be expected, were not dependent upon vision but revealed the important part taken by the kinesthetic and muscular senses in the general process of adaptation. All this goes to show that the relatively great value of sense-organs in regard to habit-formation has not yet been justly appraised. We know that the sense of touch has a very special significance in the mental life, while the various feelings associated with the position of joints and limbs undoubtedly have a marked influence upon voluntary acts as well as upon the purely intellectual processes.

Continuing the consideration of the relation of structure to habit-formation, it becomes apparent that the higher the animal ranks in the scale of development, the less exact is our information upon this subject. Experiments made upon rats† have brought out the important bearing the structure of the brain has in directing habit-formation. The possibility that an actual decrease in the brain weight might be accompanied by a similar lowering of the capacity to develop habit-mechanisms was suggested by Donaldson. Bassett, following out this train of investigation, was able to prove that a brain weight below normal predicated for the individual a decreased ability to form certain habits. These experimental conclusions as a whole support the deductions made by Manouvrier‡ that people possessing

\* Johnson, H. M., *Audition and Habit Formation in the Dog*, vol. II, no. 3 (Holt & Co., N. Y., 1913).

† Bassett, G. H., "Habit Formation in a Strain of Albino Rats of Less than Normal Brain Weight," *Behavior Monographs*, vol. II, no. 8 (Holt & Co., N. Y., 1914).

‡ Manouvrier, L., *Sur l'interprétation de la qualité dans l'encephale* (Paris, 1885).

brains above the average weight have a higher degree of intelligence. For purposes of verification of these deductions it is essential to know that a relatively heavy brain does not owe its increase in weight to pathological processes—hydrocephalus—but is the result of purely normal conditions of growth. The normal heavy brain, if its structure is of the complex type and provided other organs are functioning naturally, may be said to be one indication of an individual's capacity to form the kind of good habits that are the mark of intelligence, but we should avoid the error of thinking of the nervous system as alone responsible for habit-formation.

A phenomenon associated with the development of every habit-mechanism is, as we have seen, the increased facility that follows continued application of the stimulus. It has been observed that, when a given point in the motor centres is activated by the repeated application of a subliminal stimulus, a state of excitability results which suggests the incidence of the supraliminal stimulus. For further light upon this subject the phenomenon of facilitation of the central nervous system has been studied in apes and monkeys. Under repeated stimulation the motor area in the cortex becomes more excitable and this increased excitability persists for some time after the cessation of stimulation. The question has not yet been definitely settled whether the mechanisms of primary facilitation are present simultaneously in the cortex and in the subcortical centres. Some investigators believe that the entire mechanism is located in the subcortical areas, but the results of more recent experiments seem to show that the phenomenon of facilitation is actually dependent upon mechanisms located within the cortex itself.\*

At the present time, a closer study is desirable of the mechanisms in man which apportion the balance between

\* Brown, T. Graham, "Studies in the Physiology of the Nervous System, XXV. On the Phenomenon of Facilitation, 4: Its Occurrence in the Subcortical Mechanism by the Activation of which Motor Effects are produced on Artificial Stimulation of the Motor Cortex," *Q. J. Exp. Phys.*, 1915, IX, no. 2.

cortical supremacy and instinctive responses characteristic of the lower brain centres. When this analysis is completed we shall know much more about the factors determining habit-formation. Probably there are persons who perform certain habits as the result of the primary automatic excitation of lower brain centres, without the interposition of cortical control, while in others the execution of these same mechanisms is, as described in Chapter III, referred upward to the more elaborate functional control of the cerebral cortex.

If we knew more about the relation existing between the higher and lower centres in the brain, much light would probably be thrown upon the various integrations taking place in habit-formation. Unquestionably the processes concerned in suggestion—auto- as well as hetero-suggestion—have a great influence in shaping habits. This is illustrated in cases of hysteria. Under ordinary circumstances a healthy person is unaware of the close relation existing between attention and feeling. If our attention is absorbed in a certain task, not only do our thoughts run in one line, but various tactile and other forms of cutaneous stimuli may be completely ignored. In patients who have been subjected to some great emotional shock—soldiers as the result of their experiences in battle, overtrained athletes, etc.—it often happens that their minds become so absorbed in the contemplation of their own thoughts and painful experiences, they may be said to suffer from what are equivalent to visual and auditory hallucinations. This exaggerated state of inattention to ordinary events is followed by marked anæsthesia. Some change probably takes place in the sensory tract increasing the ordinary resistance to the passage of stimuli, and if the attention is very defective anæsthesia follows.\*

In the habits associated with the act of hearing we have to consider not merely the perceptual part of the processes, but, of equal importance, the various motor reactions con-

\*Hurst, A. F., "Psychology of the Special Senses and their Functional Disorders," *Lancet*, July 31, 1910.

cerned in paying attention. If a person with whom we are talking bores us we may soon develop "protective reactions" and not only fail to hear what he says but also pay no further attention to the speaker. This involves the discontinuance of habits depending upon higher as well as lower centres.

In some persons who have formed the habit of listening, the ability to detect sounds at a distance is increased to an astonishing degree. Military officers trained to make observations and report upon the actions of the enemy in some instances developed a remarkable acuteness of hearing—three or four times greater than that of the average soldier.

As Hurst has pointed out, the act of "looking" involves processes that are comparable to those concerned in hearing. There seems to be this difference, however—that extreme inattention is more often a cause of deafness than of blindness.

Even in what seem, at first sight, to be highly complex responses, the principal mechanism concerned may on closer analysis be found to consist of a type that is very near to the pure reflex. This is as true for man as for the lower animals. In a cat, from which both cerebral hemispheres and the great ganglia at the base of the brain have been removed, acoustic stimuli may produce evident responses, such as movements of the neck, tail, and limbs. Here then we find that reactions of a mimetic nature suggesting an attempt at emotional expression may actually take place without the intervention of a truly conscious state. It is not improbable that even in man habitual responses which often seem to be of a high order may be reduced almost to the level of pure reflexes.

Any discussion of the mechanisms concerned in habit-formation drops back continually to the consideration of the problems relating to the habituation of organism to stimuli. The special phase of the question relating to habituations in lower levels has been mentioned; so we may now turn our attention to still another aspect of the problem.

We often say that a person is accustomed to certain in-



fluences, without pausing to consider the processes involved in bringing about the state of "accustomedness." Individuals are said to become accustomed to tobacco, alcohol, morphine, arsenic, and other toxic substances when, following the ingestion, the acute symptoms of poisoning are inhibited or are not immediately apparent. There are several factors to be considered in dealing with the phenomena appearing whenever an organism becomes accustomed to any one set of stimuli.\* One of the principal changes to be noted is the alteration, a qualitative one, in the reaction of the organism to the noxious substance. A degree of tolerance so marked that it often seems inexplicable is exhibited. The cases of persons who have become, unfortunately, accustomed to large doses of morphine are familiar. It has been shown that the nerve cells of the brain acquire a great insusceptibility to morphine and at the same time take no active part, as do the cells of other organs, in the actual destruction of the poison. Animals vary greatly in regard to this susceptibility and in the manner in which they react to toxic substances.

Here the question of structure enters again as an important consideration. When the animal experimented upon stands low in the scale and there is no grouping of nerve cells to form a vomiting centre, the injection of an emetic will not be followed by this action, nor will doses of strychnine cause convulsions in animals before the time when the reflex centres are fully developed.† Susceptibility to stimulation and facility of response depend primarily upon the presence of susceptible organs.

It makes little difference from which angle we approach the question of habit-formation; the subject cannot be long under consideration until it becomes evident that the answers to many of the queries propounded involve the discussion of fundamental biologic principles. Very closely associated with this phase of habit-formation is the process

\* Heilbronner, K., *Ueber Gewoöhnung auf Normal. u. Patholog. Gebiete* (Bergman, Wiesbaden, 1913).

† Meyer, H. H., and Gottlieb, R., *Pharmacology*, trans. by J. T. Halsey (Lippincott Co., Phila., 1914).

of hyper-sensitization, or extreme sensitivity for certain substances both inorganic and organic. In a great many people the threshold of stimulation is lowered for certain kinds of substances, and this leads to the formation of definite habits.\* The question of habituation is closely related both to that of susceptibility and immunity, and for such discussion the reader is referred to books in which these topics are considered.

A realization of the real biologic significance of habits shows them to be the indices of the adjusting capacity of the individual. Good habits indicate successful and bad habits faulty adaptation. If the attention of society at large could be directed to the importance of habits as essential to successful living, a great advance in our civilization would follow: probably a greater one than any that has yet marked the progress of mankind.

One of the chief difficulties presenting itself to the student of habit-formation is the absence of any standard for comparison. This defect is due in part to the very incomplete analysis existing of the various mechanisms concerned. We do not know why persons vary in their reaction types, showing both qualitative and quantitative differences. In some cases the process of learning may be excessively slow and in others quite the reverse; or critical situations may on the one hand be faced with success, while on the other there is failure. A very interesting beginning has already been made toward the solution of some of these complicated questions. Hamilton† has indicated the methods to be used in attempting to compare the reactive tendencies of men, apes, dogs, and cats; and has pointed out some of the conclusions that may be deduced from comparative studies of this kind. It is found, in dealing with problems of a certain degree of complexity, that the tendencies may be expressed as (1) A, the rational inference tendency, (2) B, the unmodified searching tendency, (3) C, the tendency to

\* Cooke, Robert A., Van der Veer, A., "Human Sensitization," *Journ. Immunol.*, June, 1916, vol. I, no. 3.

† Hamilton, G. V., "Trial and Error Reactions in Mammals," *J. Animal Behavior*, 1911, I, p. 33.

adopt stereotyped methods of searching, or (4) D, the tendency to be modified by recrudescant motor impulses, and finally, (5) E, a condition marked by the perseveration of active motor impulses and inhibitions. The basis of comparison of these reactions can readily be represented diagrammatically. These different tendencies are, of course, largely responsible for the formation of habits specifically characteristic of each species of animal. Even in rats there is an excellent opportunity for investigating the relation of temperamental disposition to the habitual reactions, and that which is true in regard to the lower animals is more strikingly exemplified in the behavior of man. The neglect of the temperamental qualities and the interest only in the intellectual aspects of human habits, have been among the most prolific causes of failure to make more substantial progress in their study. This particular point should be brought to the attention of those educators who are not in sympathy with the biologic point of view.

A few references to specific instances in which nature has assisted in accentuating first one and then another link in the long chain of processes synthesized into habits, will be of material assistance in illustrating the advantages gained from a broad psycho-biologic outlook.

Probably no better choice of cases could be made for this purpose than those in which compulsory, spasmodic, stereotyped movements generally described as tics or habit-spasm occur. Attention was originally directed by Charcot, Janet, Brissaud, and other members of the French school of neurologists, and later by Freud and Jung, to the great complexity of factors concerned in the genesis of these movements, while these same phenomena have been made the subject of special investigation by a number of physicians in this country.

In one of these cases (reported by Pierce Clark) we have to do with a psycho-neurotic disturbance, in which the habit movements crystallize, until a spasm of the neck muscles involved in the primary disturbance becomes a chronic symptom. In many instances the symptoms

represent "a benevolent excess of functioning" which should not be suppressed until the inciting cause is removed. Generally the genesis of the habits may be traced far back to earliest infantile life. As a rule the *ticneur* is unconscious of the abnormality of his condition, due partly to his psychic state and in part to the accustomedness produced by the constant repetition of the acts. Practically no advance was made in the analysis of these cases as long as the causation was sought for in restricted neurologic conceptions—a point deserving special consideration. We need to realize, as Clark has pointed out, that these curious habits express a special biologic need of the entire personality.\*

The intimate association of a variety of habits is well exemplified in Clark's case, in which the following habit movements, tics, and obsessions were associated in a young man of nineteen years of age:

- (1) Biting and picking of finger-nails and face;
- (2) Grimacing, genuflexion, sighing, clicking tic associated with autocholia and touching of the forelock of hair, as well as an ablution tic, wringing the hands and face, and
- (3) Panics and fears that he was to faint, lose his mind, meet with an accident, or be killed.

The summary of the character study shows the kind of soil upon which these habits developed, as well as the interlocking character of the reactions, one leading to another.

A young man of nineteen, he was a shy and diffident child, not able to make a broad friendly contact with reality and the social world about him. In the absence of this normal condition he became more constrained and badly adapted throughout early adolescence. As a compensation he grew more shut in, constrained in conduct, and developed a lop-sided character. All these characteristics intensified his feelings of inadequacy, and action was blocked by doubts

\* Clark, L. Pierce, "Some Observations upon the Etiology of Mental Torticollis. A Further Study upon Mental Torticollis as a Psycho-Neurosis. Remarks upon Mental Infantilism in the Tic Neurosis," *Med. Record*, 1914, LXXV, pp. 232, 371.

and religious scruples. The sublimation of the dislike-and-indifference instinct (hate complex) was not overcome by any real push of friendliness and sympathy, largely because of the sole and intensive affection for the father. In all, we have a somewhat prolonged detailed description of mental infantilism, whose lack of emotional frankness and development has retarded intellectual advancement and altogether illy adapted the young man for proper every-day life.

Within a very limited space it would be inadvisable to try to outline many of the practical considerations touching upon the subject of the formation and cultivation of good habits; but certain phases of the subject which have impressed themselves upon the writer's attention may be briefly presented. In the first place, the highest degree of intelligence and common sense possessed by parents or teachers should be concentrated upon the periods in a child's life when habits are still in the process of formation; and these periods are generally prior to the end of the first decade. Fortunate is he who during his early life has succeeded in mechanizing a sufficient number of desirable automatic adjustments which later will assist in relieving consciousness from the strain of focussing the attention upon them; and thus enable him to do without conscious effort the task which otherwise often defeats the purpose of the undisciplined.\*

As habits are formed in response to stimulation, the question of the source of the initiative and the strength imparted by impulses springing from it should always be carefully studied. Living beings deserve fully as much consideration as that ordinarily given to the steam-engine, the boiler of which is examined prior to getting up steam, in order to prevent an explosion. The habits of later life are determined largely by the functioning of organs during the period of infancy and childhood. Of equal importance with the study of the psychology of habit is the careful observation by a competent physician of the individual, undertaken with the

\* Bagley, W. B., *The Educative Process* (The Macmillan Co., N. Y., 1912).

purpose of determining the functional capacity of different organs—lungs, heart, etc.—and the degree to which these activities are synthesized or expressed in those of the entire organism. When a general estimate has been made of this adjusting capacity, then attention may be given to the development of initiative by making the child conscious of some need which seeks expression. Gradually motives develop; and the earlier these become permanent the more advantageous it is for the child and adult. That part of the learning process by which conscious adjustments are successfully reduced to automatic levels, as has been said, is marked by waves. Extreme caution should be taken not to press the child too hard when the crest of the wave has been reached. In fact it is far better to stop temporarily and wait, not insisting on the continuance of the effort while the trough between the waves is present.

Too much care cannot be exercised in regard to the building up of the primitive mechanisms in habitual reactions. Although this fact is well recognized in learning to play games where attention is thoughtfully focussed upon forming good habits, the members of the teaching profession are, as a rule, sadly ignorant of the applicability of this principle to the higher mental processes. The position of the arms in holding the gun to the shoulder, the correct position when striking the gold-ball, are examples of the importance of good muscular habits in accomplishing an end with the least possible expenditure of energy and strength. As long as the effort is being made to acquire these movements or poise, no lapses from the correct posture are permitted. This same principle is equally applicable to the formation of habits in the higher levels. By observing closely the ordinary sitting and standing postures of different people, we get an excellent indication of the nature of some of the simpler but very significant habits which have had great influence in shaping the personality. Often a great deal of light is thrown upon the steps in the genesis of habitual reactions by observing the peculiar and dramatic attitudes assumed by patients during the course of a psychosis. For

example, during the development of schizophrenic dissociation, a patient will stand for a long time in a position which could not be maintained during health. In a short time these bizarre postures crystallize so as to form habitual reactions which can only be understood when we analyze the symptoms in detail, and try to discover their origin.

A good deal of valuable information may be obtained in regard to normal habits from observing abnormal states, because certain links in the chain stand out very clearly as the result of the prominence given to them by disease. Sometimes the analysis made by the progress of the disease leaves the way open so that we get a glimpse of the set of causes which first gave rise to these particular habits. In normal persons, however, it is not so easy to trace the links in the chain of development. We do not know all the reasons, for example, why a decided improvement in posture will often be followed by increased mental alertness, together with an increased independence and greater assurance in facing critical situations, both mental and physical; and in some cases by a general change for the better in temperament and character. Burnham\* has called attention to the close connection existing between correct postural attitudes and such desirable qualities as express effective functioning on the part of the higher brain centres: poise, dignity, and a sense of self-reliance. We must be careful, as has been intimated more than once, to regard these crystallized reactions as the product not of one but of many biologic forces acting upon the organism; and this same principle applies equally to all reactions which tend to recur in groups and are directed toward the accomplishment of some definite purpose.

The relation of each particular movement to the general motor attitude of the entire organism should be taken into account. This principle is well illustrated in connection with certain poses or attitudes occurring during the course of a psychosis. Consider, for example, the hand-shake of a psychotic patient as a means of giving expression to the

\* Burnham, W. H., "Posture as a Condition of Efficient Brain Activity," *School and Society*, 1916, IV, p. 283.

emotional trends swaying the personality. It has been noted\* that in certain psycho-neurotics, the indecision and inability to carry the hand-shake through to a firm co-ordinated grasp has a peculiar biologic significance, since there are some features of the response which suggest the movement of the hand in the higher apes. In the failure of the palm or surface of the ape's thumb to face or oppose inward, as well as in the hyperextensibility of the metacarpo-phalangeal joint, we not only have evidences of restricted grasping power but also, of even greater importance, of a lack in the cortical evolution of parts of the brain controlling these muscular movements. We find, then, in the well-marked peculiarities of the hands of some of the patients suffering from schizophrenia, evidences of atavistic types of structure common among the higher apes. In order, however, to understand the full significance of these habits, we must go still further back to see in what way these responses are represented in "the mind" which expresses the final synthesis of all the reactions of the organism to its environment.

In every habit we should analyze first the special movements which attracted our attention and should study them as far as possible individually, but for the interpretation of the habit, of equal importance is the relation these movements bear to the general reactions of the entire organism. This latter field is one that has been neglected, and this defect should be remedied if we expect to develop a comprehensive view of human behavior.

The history of the following case of a soldier who came under the writer's observation illustrates a number of the points to which reference has been made. The soldier was an intelligent, "high-strung" type of personality, who, while under observation, had a number of tic-like movements of the muscles of the face, head, and neck. The following information in regard to his trouble was elicited in response to questions.

\* Stoddart, W. H. B., *Mind and Its Disorders*, 2d edition, pp. 338-339, illust., London, 1912. Langdon, F. W., "Biologic Aspects of Dementia Præcox," *Am. J. Insanity*, 1917, LXXIII, p. 681.



He was of a nervous disposition, although prior to the onset of his present nervous symptoms he had never been incapacitated from performing the ordinary routine duties of life. This patient was glad to enlist in the army and anxious to do his bit, and therefore did not go to the front against his will. After he arrived in the front-line trenches, he began to get nervous, and this nervousness increased as the stress of military life and the dangers became greater. He was in a number of battles, and since these took place early in 1915, when the military conditions were unfavorable for the Allies, he knew from experience what hard fighting was. After each battle he appreciated he was becoming more nervous and apprehensive, and at the end of the first month of trench warfare he began to be afflicted with involuntary movements of the head and face. The state of apprehension was most marked just after the order had been given to "prepare to go over the top."

Word was generally given about one-half or three-quarters of an hour before the attack was made, and this period was described by the patient as "awful." The charge did not seem to be as bad as the waiting. All the nervous symptoms were increased by his being partly buried by the explosions of large shells. Finally, after five months at the front, he collapsed entirely after having been half-buried for the third time in one day, under dirt thrown up by a very large shell. He was dug out by a comrade and remained in a stuporous condition for two days.

The nervous habits formed, as the result of his experiences, had a very interesting relation to his emotional upsets. Every few seconds his head was drawn to the right side and slightly forward, as if in the process of ducking to avoid an obstacle. The muscles of the face also contracted sharply, resulting in a partial closure of the eyes and a puckering of the lips as if he were about to cry. Even to a casual observer it was apparent that, under great emotional stress, dodging and avoiding reactions of the muscles of the head and neck and of the facial muscles expressing fear or apprehensiveness, had crystallized and become the objective reminders of the experiences through which he had passed.

The significant part played by underlying currents in determining these habits was very evident, and the movements were excellent examples of one form of perseveration; although the phenomena generally described under this head have quite a different genesis and significance. Of course, in observing these nervous reactions, one is greatly impressed, as in this case, by their "inappropriateness," in their continual recurrence. This latter feature needs to be carefully considered in analyzing habits.

Perhaps too much attention has been paid to the psychology of habit-formation, while the broader, more suggestive biologic point of view has been less utilized. Habits, for reasons already stated, should not be regarded merely as functional expressions of the nervous system alone. In discussing the general trends of activity, occasion was taken to trace the origin of the predispositions concerned in special mechanisms to organs quite outside of the nervous system. So important is the recognition of the general factors entering into the building up of responses reduced by constant repetition to the lower levels and recurring automatically, that we should take close account of the manner in which these stereotyped processes are gathered about the primitive instincts, acting as magnets attracting other elements into systems which form the more fundamental types of mechanisms. We shall find that if we turn our attention squarely to the adaptation which takes place in the higher levels of activity, many of the difficulties generally met with in attempting to analyze these processes will disappear, if the attempt to establish artificial lines of division between functions or faculties is not pushed too far.

On account of the effort made to obtain data to prove the truth of a theory, we find many psychologists insisting that the higher adaptations or the mental life, in the narrow sense, consist only of sensations and representations, and that the feeling tone is a characteristic of the sensation, while practically no account is taken of the various phases of activity represented in the volitional life. These views are in marked contrast to those of other psychologists who

emphasize the processes of apperception, laying particular stress on the importance of the subjective sensations connected with the attention as well as the existing tension in the muscular system, all of which are said to represent the chief factors in the conscious adjustments.

The actual integrating activity of the energy expended in these higher levels does not depend upon any one set of functions, but is probably due to the regulations imposed upon the distribution of the streams of energy by the living brain substance, or—as Berze has described it—by the psychic biotonus. In other words, the energy of the higher brain centres, which is often partially expressed or represented in the processes of sensation or perception, is an index of the general biotonus of the organism. The completed circuit by which these biologic reactions are measured begins with the link designated as “sensation,” and ends with the so-called “motor-response.” In this chain or continuum we find, in addition to sensations, perceptions, emotional states, intellectual processes, the specialized activity recognized as volition, although it marks only one phase or link.\*

The mental processes in the synthesis of the personality give rise, on the one hand, to voluntary acts, and on the other to thoughts or emotional states. When the synthesis is complete, there are many processes of which we are never directly conscious, and these represent mechanisms confined almost entirely to the lower planes of activity. French students of the former class of phenomena have been accustomed to speak of a superior psychic activity in contrast to the inferior psychism which represents the functions of subcortical centres, and which comes plainly into evidence whenever the control of the higher centres is removed by disease. The more complex forms of consciousness are not infrequently subordinated to the influence of latent or hidden impressions which suddenly crop up when the normal repressive influences are weakened.

\* von Wieg-Wickenthal, K. E., “Psycholog. Betrachtung über Intellekt u. Wille,” *Zeitschr. f. d. Gesamt. Neurol. u. Psychiat.*, 1915, XXVIII, p. 129.

The consciousness of a normal person indicates the existence of a certain degree of biotonus, which may be roughly estimated by the activity of apperception; a function some psychologists consider to be the "*spiritus rector*," or active dominating force.

## CHAPTER X

### INVOLUTION OF THE PERSONALITY

THE more easily recognized symptoms of aging have often been described and some of these descriptions, such as Cicero's, have become classic. The correct interpretation, however, of such phenomena and the estimate of the various biological mechanisms called into play during the later periods of life, are now counted as among the most important problems of modern biology. A fairly complete philosophy of life, based upon biologic principles, should aid greatly our understanding of the behavior of old people, our appreciation of the source of their motives, and comprehension of their symbols of speech.

In order to gain this standpoint there must be ability to comprehend by means of an accurate knowledge of the phenomena of growth what is actually taking place during the period of involution. Aging follows the cessation of the growth processes, and therefore the insight possessed by the investigator into the nature of the general biologic processes counts for a great deal in studying the various phases of life both at its earlier and later stages.

The mere description, cataloguing, and indexing of the symptoms of old age without an attempt to co-ordinate them and thus to show their general relations, would only leave us in the dark as to the meaning of the changes in them, particularly in those manifested in the higher levels of adjustment. Nor can we afford to neglect what may be called the vital side of the problem, although this is the side that has attracted the most notice and has been immortalized in literature. Our present task necessitates an attempt to go below the surface and to trace, as far as possible, the mechanisms that in any way seem to be responsible for the changes in behavior characteristic of the period of involution. What

has been said in other connections about the relative unimportance of the conscious processes, holds true in the study of the personality at this time of life.

The period marking the drop in the "life curve" of any human being completes a cycle. Without this decline the rise would include only isolated, apparently unrelated phenomena. Superstition, conventionalized thinking, and the fear of death have often prevented the human mind from recognizing the necessity of the period of diminishing capacity for adjustment in the final synthesis of a long series of vital phenomena. And the same influences have tended also to give us a very imperfect view of the life of any organism, and especially of that period marking the completion of the life-cycle.

The period of senescence, or aging, is associated in our minds, to a large extent, with the idea of deterioration. Unfortunately, many of the artificial conditions of life and the so-called civilizing agencies have tended to accentuate the idea that growing old is a process always closely allied to pathologic states. We forget that the same criteria might be applied to certain aspects of many processes associated with growth and maturity. Although we practically never meet with examples of unrestricted growth nor with perfected maturity, there is not the same inclination to regard these processes as abnormalities, because the growing and maturing processes are recognized as related and as forming the links in a long chain of events, while the aging process is supposed to belong to a different category.

Senescence to us means too generally an entirely new and supplementary chapter in life's history, a chapter involving the consideration of a distinct and unrelated set of biologic phenomena. This erroneous notion presupposes the existence of specific functional differences and has added another to the difficulties of investigators in their approach to the problems of human behavior. This has of course led, with the peculiar emotional disposition toward the subject of old age, to the further complication of a problem already only imperfectly conceived and formulated. There has also been

a strong tendency to form elaborate hypotheses based on a few facts of not always great importance.

From the descriptions of philosophers and poets who have written of old age, we have acquired the habit of accepting figurative statements embodying superficial, but sharp, contrasts in functions, as if these represented the actual biologic conditions. Popular traditions, also, such as the comparison of old age to second childhood, have served as a basis for unwarranted deductions as to the nature of the changes in the involutionary period. Except for extremely superficial likenesses and contrasts, the periods of old age and childhood are in all points widely separate, but the few features in which this contrast is lacking are usually selected to emphasize the likeness. This is of course a mistake, since we cannot discuss intelligently any period of life without readiness to search diligently and patiently for the fundamental biologic facts; and when these are not accessible the part of wisdom is to reserve judgment upon them.

Other difficulties obscure our correct view of involution, and at times prevent our progress toward its comprehension. With the prejudice of superstitions confronting the student, there are the conventionalized beliefs concerning it. These beliefs have in many persons so strong an emotional setting that they assume to them the appearance of incontrovertible evidence; while the old person has naturally had an interest in promulgating views not tending to impair his prestige, interfere with his prerogatives, or repress instinctive cravings. The current views as to the physiology of old age merely symbolize all these reactions.

Another of the difficulties that prevent the correct interpretation of many of its phenomena is the disposition to assume the existence of specific factors as distinguishing the various epochs of life. This merely continues the doctrine that has taken such a prominent part in the history of biology with, as its outcome, the assumption of the specificity of one and then another function. The same attitude of mind has been responsible for the fallacious ideas promulgated about the nature and extent of changes in behavior

incident to the seven ages of man, that we have seen have been current in regard to the brain and nervous system, which were assumed to possess specific qualities inherent only in them.

As far as we now know, it may be said that there are no specific factors introduced during the entire life of the organism. Every link in the chain is reciprocally related and the significance of one link can only be comprehended by studying its relation to the whole process. We must form the habit of considering the life-cycle as a functional and harmonious unit, and never dissociate the various events as if they were unrelated. We must learn to recognize the connections between the logic of reasoning and the logic of growth.\*

The belief in specific biologic differences between youth and senescence grew up around the notion that, during the period of growth, certain mystic forces are in operation. It was further assumed that, when maturity is reached, these subtle influences are no longer felt and consequently aging is supposed to begin.

Unfortunately, we know too little about the nature of the occurrences shaping the course of life during any one period. We can only state that there is no evidence at present favorable to the supposition of specific differences dividing one from another period, and then make the effort to think in terms of relative values while abandoning any thought of universal standards and artificial distinctions. With this accomplished our perspective will be truer of the main characteristics, and our judgment more correct of the interdependence of the events occurring during the periods of the rise, maturity, and decline in the cycle-life.

In our study of senescence we must not expect to find simple explanations for what is a complicated process. This expectation has led to the same undesirable and unfortunate comparisons between old age and childhood as at other times insisted upon their likeness. The view that in the senes-

\* Kappers, C. U.<sup>1</sup>A., "The Logetic Character of Growth," *J. Comp. Neurol.*, Dec. 15, 1919, XXXI, no. 2, p. 51.



cence the organism, even in the mental adjustments, returns to the conditions of early life is based upon very superficial reasoning and gives undue prominence to a few factors which, for their proper understanding, demand study in their rightful setting.

It is possible that this comparison is the result of our regard of involution as a process of simplification of function; but this is merely because some of the phases of this phenomenon are suggestive of this conception, which may be attributed, perhaps, to the undoubted fact that one of the most prominent features of the second half of life is the limitation imposed upon the capacity for adaptation.

The range of adjustment is limited, but not quite in the crude way thought obvious. The reactions are not more elemental than formerly, and neither is the apparent reversion due to a lopping off of points of contact with the environment. Since compensation and compensating reactions complicate the situation quite as much at this time as at other periods, we must use caution in enumerating the chief events as marked only by reduction, dedifferentiation, and rejuvenescence. Old age is not when biologically considered a reversal to the primitive type, but is expressed in a whole series of reactions which are modified by preceding ones. It is not strange that in many respects there should be resemblances, superficial as they are, between the reactions of old and young people; but the chief signs of the two eras are products of entirely different factors. Moreover, the processes in old age are progressive, not regressive, in character.

It is not our present purpose, however, to refer at any length to the basic changes occurring in the organism, which in a general way seem to be characteristic of the various epochs of life. The structure of the cells of the body have been made the subject of special study by many investigators, although we are still in doubt as to the nature of many of the changes.\* But it is possible that some reference to

\* Conklin, E. G., "The Size of Organisms and Their Constituent Parts in Relation to Longevity. Senescence and Rejuvenescence," *Pop. Sci. Mon.*,

the general character of the tissue changes, particularly of the nerve cells, during senescence may make for a better conception of the nature of the entire process. The decrease in the fundamental metabolic reactions comes on after the prime of life has been reached; or, as Conklin has put it, there is a slow interchange between the two chief parts of the cell. This reduced metabolism is one of the principal signs of senescence. During this process of aging there is an atrophy of the cell body and its nucleus, the latter tending to disappear the first. There is, of course, associated with these structural changes a diminished capacity to recuperation of function and an apparent dominance of the katabolic, or destructive, process over the anabolic tendencies. "Natural senility," according to Dolley, "is one of organic exhaustion." Any depressing factor, if carried too far, may result in permanent disorganization of the cell, and this constitutes an organic senility of depression. This is in contrast with the period of youth, when there is a rapid interchange, or metabolism, constantly going on within the cells, while the various products formed during the differentiation processes are quickly consumed and all injurious by-products are thrown off. Sooner or later in life the conditions reducing metabolism are sure to set in and then, although there may be a temporary recovery due to a let-up in the strain imposed by prevailing surroundings, there is no rejuvenescence. Dolley regards senility of function and senility of depression as corresponding with the diminished functional metabolism generally designated as the senile condition.

This suggests another point to be kept in mind in our preparation for a study of old age, namely, the relative importance of the environment in affecting the various readjustments. The principles enunciated in Chapter II in the discussion of the nature of a stimulus and the general char-

1913, LXXXIII, p. 178. Minot, C. S., *Age, Growth and Death* (G. P. Putnam's Sons, N. Y., 1908). Child, C. M., *Senescence and Rejuvenescence* (Univ. Press, Chicago, 1915). Pearl, Raymond, "The Biology of Death—the Problem," *Scientific Monthly*, 1921, XII, p. 193.

acteristics of a reaction are equally applicable to these conditions. We are too much inclined to endeavor to explain the various phenomena as the result merely of the diminishing influence of external conditions; but there is excellent ground for the belief that mechanisms concealed within the organism are the directing forces at work, so that, instead of a passive state, we are still dealing with active processes. This is an additional reason for care in seeking explanations of the aging process. For example: when we notice an apparent considerable reduction of the number of contacts with the environment, because of the limitations imposed upon the sense-organs, it is not advisable to jump to the conclusion that these restrictions are therefore retroactive and consequently that they must give rise to potent secondary influences. This may be and often is true; but, on the other hand, there are many occasions when the immediate effects do not at once become obvious, and are the means of errors whereby some reactions, concerning the nature of which nothing is known, are attributed to what superficial examinations determine as the inciting cause. Some of the results to which these hasty conclusions may lead will be mentioned later; but the precautions to be observed in studying adjustments in any level will be found applicable to all levels.

The periods of growth and involution have both had their historians: students, as we have said, of a restricted symptomatology. Our impression of the relative simplicity of the processes has been largely derived from the emphasis they have laid upon certain phases of them. This impression is only permissible if we insist upon the precautions already stated, and neither allow ourselves dogmatic conclusions nor too many inferences from the result of what are necessarily but casual observations. In studying old age we must, as heretofore in our study of growth, consider both mind and body, and as often as possible take account of the relationships between the two sets of phenomena. Because of the paucity of facts this body-mind relationship can only be described in very general terms.

The somatic changes beginning after the prime of life has been reached are demonstrable in practically all the organs of the body, and include a variety of different forms depending very largely upon the character of the tissues in which they occur. No categorical definition of these alterations is possible, since it is necessary to distinguish carefully between the signs of normal aging and the changes precipitated by the action of disease. Beside these two distinct sets of conditions, definite pathologic processes may arise as secondary complications of physiologic old age.\* Moreover, it is sometimes not possible to state when the normal or average physiologic rate of progressive changes going on in the body has been accelerated by disease. Nor can we, as a matter of fact, say why it is that we do grow old.

Metchnikoff was the first person to call attention to some of the more important phenomena of senescence, such as the phagocytosis, the destruction of the bone and muscular elements, and the autolysis, all of which were thought to be the result of chronic intoxication.† But the factors themselves that lead to this breaking down of tissue we do not yet know, or why the multiplication of microbes comes about at this period.

Our familiarity with certain similes in the description of the phenomena of old age has been productive of the supposition that these processes were well understood. Nothing is further from the truth. "Aging," we have heard, "is a manifestation of life." But it is truly a very complex manifestation and not at all comparable to the wearing out of a machine, while nothing very much is yet known about the wastage of material so frequently noted as indicative of this period. Its comparison with the changes taking place in inanimate objects is also apt to be misleading, and only emphasis upon its exceedingly complex nature will ever aid us in gaining a correct perspective of the significance of the many changes under consideration.

\* Nascher, I. L., *Geriatrics, the Diseases of Old Age and Their Treatment* (P. Blakiston's Son & Co., Phila., 1914).

† Metchnikoff, E., *The Prolongation of Life* (Heinemann, London, 1907).

Such theories as those purporting to reduce the entire process of growing old to the study of alterations in the tissue following disturbances in the blood-vascular systems, are one-sided. No matter from what angle we approach the subject we are very soon brought face to face with such questions as relate to the sources of energy in the body and to the regulation of its flow by the different organs. More light thrown upon such problems will better equip us for an understanding of what happens when the supply begins to fail and when restrictions are placed upon the capacity of the adjusting mechanism.

Some of the more recent theories propounded to account for the incidence of old age as a pathologic state are revealed in Horsley's view that old age is the result of a degeneration of the thyroid gland, or in Sorand's elaboration of this idea to include alterations in the ductless glands. It is well known that in conditions described as senile cachexia, there is a diminution of the secretory function of the thyroid gland. It is also of interest to note that at this time of life there is an increase in the lime salts which may tend measurably to offset the reduced activity of the thyroid. But such a compensation merely illustrates the fallacy of considering any of the organic processes as independent of other functions.

The same principle applies to the adrenal glands, although the facts are yet more dubious in their case, since there is still considerable doubt as to whether their secretions are increased or diminished with the onset of old age. The theory propounded by Metchnikoff, suggesting phagocytosis and auto-intoxication as characteristic phenomena connected with aging, has been perhaps the theory to attract most the attention of the public. But in this, as in all the other theories, there is no really broad biologic view of what is undoubtedly a natural phenomenon. Only by giving due weight to the relative significance of the complex physico-chemical processes inherent in growing and aging, will intelligent discussion of the changes be possible.

Biologically considered, senescence is a necessary and

integral part of the development cycle, for youth itself in its turn is the product of the old, and not of "a self-perpetuating source of youth which is itself always young." \*

The complexity of the problems of the development of a human being which we have discussed in the preceding pages should prepare us for the complexity of the nature of the compensatory reactions during old age. It is not only a reduced capacity for adaptation that we have under consideration, but something of nature's processes in limiting this range must be understood, for which we need acquaintance with the various steps in the building-up process or synthesis accompanying growth. For this understanding we must begin with an analysis of the mechanisms tending to complete the cycle of life. In such investigation again we must turn to a discussion of many of the more fundamental biologic questions. For this purpose it is obvious that we must take into account the influence of nature and nurture upon capacity and acquirement, and thus form some idea of the contribution of each to the synthesis of the personality. With this knowledge in our possession we should be able to arrive at some conclusion in regard to the conditions prevailing at the onset of the era of reduction. But in this estimate the capacity for acquisition and mental adaptation must be considered, not separately but rather together, since the former is exactly as much the result of stimuli as the latter, although this is usually considered as the product of innate forces.

Observation alone should be somewhat informing of the intimate connections between the two groups of forces, although the character of the stimuli varies. We see children, for instance, with aptitudes possessed by the parents and who may also gain some of the parents' acquirements; but in our present state of biologic knowledge the intimacy of the two connections is recognized without any satisfactory explanation of the manner in which they are related. Such an example shows the futility of expecting to understand fully what takes place during youth, maturity, and old age.

\* Child, C. M., *opus cit.*

As a matter of fact, we can neither follow the details of the era of restricted adaptation, nor can we interpret the phenomena of old age until for the former we gain some further knowledge of the occurrences of the early years when the range of adaptation is being extended, and for the latter until we make more headway in our investigation of behavior during the formative periods of life. With that accomplished we shall have to advance along other lines, and estimate the influence of biologic factors modifying the final results as exhibited in individual lives. The machinist who is most successful in taking apart any apparatus is likely to be well acquainted, not only with the general relation of the parts, but with the methods proved to be most satisfactory for putting the parts together again. So also the comprehensive knowledge of a structure such as a house requires comprehension both of the steps followed during the periods of construction and demolition and of the manner in which it has functioned during the period of occupancy. Exactly the same principles hold good for life at any period or point from which we choose to regard it. Accurate knowledge in regard to the details of the period that happens to be the central object of study and the relation of these phases to preceding and subsequent ones must be acquired before thorough investigation is possible of a period representing as a whole the synthesis of life-reactions.

In our observation of senescence we are in the habit of affirming that the store of mental acquirements is generally affected before there is any marked break-down of the mechanisms controlling the natural aptitudes; in a certain sense this is true. An active force appears to be operating to reduce the number of the acquired traits, whereas there is no evident change in the instinctive tendencies. We also observe that the capacity to respond to the spur of experience may seem to be considerably interfered with without signs of disorganization among the lower levels of instinctive adjustments.

But, on the other hand, an obstacle to critical analysis of the actual existing conditions has been unintentionally

created by the sharp distinction we make between the *innate* and *acquired* faculties. Endless confusion has resulted from preserving these misnomers and the assumption that the lower levels are more innate and consequently more intrinsically a part of the organism than the acquired traits.

We must not assume that the mechanisms forming during old age are merely the results of the lower instinctive levels shoving themselves, as in infancy and early childhood, to the surface. This is one of the basic dissimilarities between old age and childhood, and is due to the principal somatic changes taking place at the two epochs. In the structure of organs and tissues, as well as in the various functions, we see evidences of progressive differentiation, but practically nothing suggestive of regressive changes. Neither instincts nor tissues show in senescence any reversion to earlier types, whereas there are extreme variations in vitality, metabolism, and mentality. There are, consequently, more reasons for dwelling upon the divergencies than upon resemblances in the two periods. The most marked contrasts between them are found in the demonstrations of varying relations between stimulation and response. In childhood the threshold of irritability is lower and the promptness of the reply is far quicker than during advanced years; and another significant factor is the wide margin possessed by youth between the range of normal functional activities and their physiologic limits; whereas during the latter part of life there is marked diminution between the actual and potential working capacity with a reduction of the available reserve energy. This change seems to begin coincidentally with the lowering of the growth force (bathism), which in turn diminishes the directing capacity of the brain (phrenism) and nerve system (neurism).

Because we do not know the cause of aging it is not possible to state when the phenomena connected with it begin. There is no special time of onset nor regularity of order in the senile degenerations. Sometimes the functional disturbances seem to precede all organic changes by a very considerable period of time. It is often most difficult to rec-



ognize the significance of early signs or to trace their genesis, since the initial symptom may be often only impaired co-ordination without any great emphasis laid upon special functions. At other times, usually after the initial stages are passed, there is an appreciable diminution in both the intensity and frequency of the impulses, although we do not think that these delayed reactions ever precede the disturbances of co-ordination or deficient synthesis unless there are special local lesions as the result of definite pathologic changes. The first signs of this failing co-ordination are generally difficult to recognize and their significance is seldom correctly appraised. The initial symptoms of the restricting forces may be hidden, or of such a character as not to suggest their genesis. It is only through an intimate knowledge of the personality that we are likely to gain familiarity with the dispositions and habits that give certain definite characteristics to old age.

Therefore, because the period of involution is marked by changes scattered all through the machinery, it is not surprising that the associated signs of limitations in adjustment should occur in practically all levels, physical, biochemic, reflex, automatic, and conscious. Such conditions are responsible for the disturbances of reflexes, automatic acts, temperament, emotion, will, sensation, and intellect as we see them in advancing years.

The mechanism of adjustment, the brain and nervous system, presents changes which are regarded as pathognomic of the final stages of life. After the fourth decade there is a demonstrable diminution in the volume and weight of the brain accompanied by alterations in the cellular elements. We find associated with the senile disorders in securing mental adjustments an increase in the supporting elements, the neuroglia, as also alterations in the blood-vessels. Since all grades of intensity are represented in these changes it is quite impossible to say at what point the conditions recognized as normal for a certain period of life become transformed sufficiently to pass the limits generally assigned to the abnormal. Our standards for determining

this question are necessarily relative and much depends upon the personal point of view in deciding whether the individual case does or does not fall within what is considered the normal line. Conventional suppositions as to the state recognized as health or disease embarrass us in our attitude toward this subject also.

It has almost become a habit with some writers to discuss symptoms of old age as indicating a distinct regression. But repeated emphasis must be laid upon the progressive characteristics of senescence as standing out in marked contrast to those regressive changes cropping up at various epochs in life. The mistake may doubtless be partly attributed to those phases in the intellectual life which in advancing years spring into prominence as infantile traits and archaic qualities, all of which suggest to the casual observer a reversion to childhood.

But one or two points very noticeable in our contact with involution may be noted. Perhaps the most obvious of these is the fact that the more recently acquired memories are the first to drop out, and that there is a tendency to live engrossed in the recollections of the past. The satisfaction in living becomes more and more centred in the immediate surroundings, somewhat suggestive of the mental attitude of a child, although, as a matter of fact, the disposition of the mind toward life at the two epochs is very dissimilar. Childish curiosity and desire to examine and analyze are altogether a contrast to the old person's inclination to turn away from analysis to synthesis, because the former is more apt to suggest the approach of the period of failing powers and final dissolution.

The analysis of the emotional and mental traits of an old person offers many difficulties. It is natural that a good deal of resistance should be exhibited to uncovering concealed mechanisms, because of a keen dislike to facing the realities of life or to recalling memories indicative of dilemmas not successfully met. Also by reason of a semiconscious realization of the inability to reorganize life along new lines the analysis may suggest that illusions have influenced

behavior and false premises have occasioned erroneous deductions as to the conduct of life, although there is much reluctance to admitting such mistakes unless unavoidable.

Men present no turning-point in life as distinct and sharply marked off as there is in women at the climacterium.\* The evidence offered by some writers to prove that there is a corresponding period in the male is not conclusive, and would rather indicate the existence of decidedly abnormal conditions. Some French clinicians have referred to the period between forty and fifty years of age as "le cap terrible des quarantes ans," implying that during these years circumstances in the lives of many men call for a number of readjustments. Such disorders, however, are nearly always attributable to more or less obvious disturbances in the distribution of forces marking the end of a physiologic period. Any considerable changes at this time point very clearly to organic lesions sufficient to account for the disorders. These evidences of maladjustment should be thoroughly studied, and it is always advisable that men should at this time of life be examined by a physician with a view to detecting the first evidence of what may become a serious disorder, and when possible all failures in adjustment should either be corrected or some compensation made for them. Life may often be prolonged by this precaution of tracing evident weakness in the machinery, and thereafter diversion of some of the energy into new channels not only promptly relieves the strain in one direction, but most certainly is productive of increased efficiency and pleasure in living.

Each person owes it to himself, his family, and his community to have such an examination made at least once a decade, for the purpose of detecting, as soon as possible, injurious influences and either eliminating these or, by rearrangement of life, reducing the strain thrown upon the organism. When these examinations become a part of the routine of life, we may expect to do away with many of the

\* Hopkins, A. H., "Climacteric Hypertension; a Study of High Blood-Pressure During and Following the Menopause," *J. Amer. Med. Assoc.*, June, 1919.

tragedies ending now in death or that worse sorrow, a period of prolonged suffering, equally the results of preventable causes. Such precautions should make possible more knowledge of the conditions associated with and responsible for normal aging.

At the prime of life by noting the characteristics of the ego we can form an excellent idea of the completeness of the synthesis of activities and the degree of harmony while the energy is being distributed at all levels. The degree of egotism denotes whether or not the balance has been maintained fairly well in the individual's struggle to adjust life. As the man or woman enters upon the period of decline, if an exaggerated egotism already exists, this is likely to be intensified. Then when the physical and mental forces begin to decline there comes an appeal to the imagination to strengthen the failing subjective sense of adequacy. Unless the situation is met with some real appreciation of the basis for the inadequacy, the defense reactions, which tend temporarily to bring relief and for a brief period supplant the feeling of inferiority, hasten the multiplication of the aggressive qualities to an extent liable to interfere with friendly intercourse. Indeed many perversities of character in elderly people may be ascribed to their precipitate attempts to conceal any evidence of their failing powers. If the person has no inclination or ability to work off energy in some form of activity, the domineering ego may succeed in controlling his or her actions to an astonishing degree.

The rapid extension of all egotistical qualities of involution is the logical outcome of the reciprocal compensations consequent upon an unbearable sense of inferiority. So imperative is the need to get away completely from any form of harassing thoughts, that all idea of aiding in social cooperation is quickly lost, a loss which explains the development in old people of traits characterized by extreme introversion, and the turning of their attention upon themselves to the exclusion of interest in their environment. The garrulity often making this symptom doubly oppressive to other people is due in part to the lessening of inhibitions,

but is also the result of the ardent desire to regain lost prestige and again become the centre of interest. Sometimes the conversation of old people amounts practically to their talking with themselves, since the right of others to be heard is persistently ignored.

The character of the thought-processes during senescence may be decidedly modified by a variety of conditions. There may be a break with reality in order to dodge uncomfortable situations or to avoid defeat in facing real or imaginary situations. Whenever this happens there is a more or less rapid accumulation of energy necessitating either an immediate discharge in the form of an impulse or a complete repression. The danger lies in the explosive tendency of the repressed energy; although fortunately, the danger of this mechanism is diminished by reason of a considerable and progressive reduction of the energy generated.

The part played by the subconscious levels in shaping the personality during the latter part of life is very great. The repressions, which may have been up to this time effective, begin to give way and there are suddenly uncovered what are erroneously thought to be new traits of character. A wife may then be amazed at the unexpected revelation of qualities she did not know her husband possessed, or the children may wonder at what they suppose to be the inexplicable behavior of the parents. But these sudden transformations are due to the relaxation of the censorship which for years may have hidden some of the real traits of character. Such shifts as these are likely to occur in the puritanical type of person who has succeeded in repressing romantic tendencies and has lived in an artificial environment. During the first half of life the evidences of artificiality in the shape of modesty and coyness have stifled all constructive activity; then in old age there comes a sudden outburst of the repressed emotions leading to strange vagaries and inexplicable acts of behavior decidedly juvenile in character.

There is another form of mechanism which may induce a rapid change in personality subsequent to a break with

reality. The person reacts as if forced into a corner with no prospect of getting rid of a critical situation. Indeed, no attempt to escape is made—the eyes are closed to the real situation and refuge is sought in fictitious surroundings constructed by the imagination. The artificial environment demands a complete change in the personality, and the entire perspective is shifted to include new fields, while the egotism involves a loss of the sense of proportion and relationship to the actual environment. The subsequent introversion has the effect of transferring personal responsibility to others. Criticism of the acts of friends and the world in general is often captious and exceedingly harsh. A person in growing old may become weary of staring at personal acts and excessively annoyed by the recurring sameness of thought and the narrowing limits of mental vision. This tendency is present even in the most disparate minds and very difficult to overcome. The expanding egotism feeds on itself and each new occurrence or acquaintance is used to extend the range of control and increase the sense of assumed superiority.

It is most instructive to observe the subtle way in which the assumed infallibility of old age develops. In it we have an opportunity to study the elements of fanaticism and the various protests against the fundamental feeling of inadequacy that become more and more urgent. The "self" is a vortex into which all lines of thought and feeling are sucked, with apparently no escape from the process. If the relation of some fact is not plain it is at once colored to fit into the picture painted by the imagination. Mysticism here again is found a refuge in its anæsthetizing powers. Many of the real qualities of temperament and character disappear and there comes about a complete break with actual life, leaving the way open to various forms of pedantry and vanity. The fog of mysticism is likely, too, to be the climax in an attempt to complete a process of ratiocination when the affective life still remains partly under the control of the repressive influences.\*

\* Lodge, Sir Oliver, *Raymond, or Life and Death* (Doran, N. Y., 1917).

Some writers have called attention to the mental vertigo accompanying much of the mysticism which, like a curtain, conceals repressed memories, disappointed ambitions, and unsatisfied desires. It is extraordinary to what extent intelligence may relax in the control of the thought processes. The attention is attracted to theories remarkable only for vague abstraction and semi-insane notions. Similar forces also induce beliefs once rejected which are now given the appearance of rejuvenescence by being clothed in semi-scientific and semi-literary garb. With the increase of associated mental confusion some attempt is made to formulate inarticulate wishes; and in some cases there seems to arise an ungovernable desire to ponder over insoluble problems or to permit the emotions to be harrowed by disturbing thoughts.

Wishful thinking enters also as a determining factor into the expression of the mysticism and adds complexity to the situation. In the case of intellectuals the directive action of the wish may be illustrated by the position taken in the discussion of such questions as those pertaining to possibilities of communications with a spirit world or reincarnation. The testimony in regard to the genuineness of alleged post-carnate communications bears witness to this tendency. The following testimony is but one instance of this, and is an example of the fact that the strength of the testimony lies rather in its emotion than in its logic:

"My body's very similar to the one I had before. I punch myself sometimes to see if it is real, and it is, but it does not seem to hurt as much as when I punched the flesh body. The internal organs don't seem constituted on the same lines as before. They can't be quite the same. But to all appearances, and outwardly they are the same as before. . . . There are men here, and there are women here. I don't think they stand to each other quite the same as they did on the earth plane, but they seem to have the same feeling to each other with a different expression of it." \*

\* Hermann, E., *The Meaning and Value of Mysticism* (Pilgrim Press, Boston). Buckham, J. W., *Mysticism and Modern Life* (Abingdon Press, N. Y., 1915). Flournoy, T., "Une Mystique Moderne," *Arch. de Psy.*, 1915.

The mysticism of the communication is paralleled by that of a commentator, who adds, "There, then, is evidence, such as it is, that the planets are evolved to evolve the souls, and that ebbing done the souls pass on, and in the higher planes no new ones are evolved." In this and similar cases it is evident that the direction of desire gives both tone and shape to the intellectual processes. Only those aspects of the phenomena are admitted as evidence that tend to give momentary satisfaction to the heart's desire.

In connection with the exaggerated states of mind of people undergoing the aging process there is an excellent chance to acquire valuable information as to the so-called normal attitude of mind upon such questions as the estimation of social values and prestige. From the psychologic level alone we cannot approach successfully such problems. We must constantly bear in mind that the majority of processes are of a decidedly archaic and primitive type; and that the formation of personal judgment is influenced by waves of feeling and sentiment set in motion by disturbances occurring far below the surface and not entering even directly into the field of consciousness. For these reasons it is desirable to speak of a socio-biologic instead of a socio-psychologic level from which to enter upon the discussion of the genesis of the sense of prestige.

This particular angle of approach should be serviceable in making clear, among other things, the *raison d'être* of democratic institutions and the lines to be followed in the future to strengthen the foundations of a "government of the people, for the people, by the people." So many of our pleas for democracy proceed from the same sense of inadequacy that is the source of the warped judgments and foolish prejudices of old people, that we should be familiar with the forces in operation in the control of the genesis of these sentiments.

Sometimes in the prime of life we have an unusual opportunity to begin to trace the links in the chain by which a genuine and well-deserved sense of prestige becomes gradually transformed first into some strange antipathy and



then gradually into the crystallization of a strong prejudice lying entirely outside the field accessible to reason. Or again, we are able to observe what happens when there is a break in the sequence of thought, and logic is trampled under foot by the sudden incursion of waves of emotion. Leopold\* compares the growth of the sentiment in childhood and old age. To us, however, he seems to make the mistake of taking for granted the similarity of the mechanisms concerned in this phenomenon in the two epochs. Although the symptoms, themselves, undoubtedly have many points in common, the processes responsible for these special reactions are almost diametrically opposed to each other. As in those other connections alluded to earlier in the chapter, the child is engaged in forming new values and is urged forward by continual stimulation from reserve stores of energy; whereas an old person is occupied in curtailing the list of people to whom he is willing to accord prestige. In a child, a sense of credulity is not, with the exception of distinctly abnormal cases, associated with selfish motives; whereas the increasing years tend markedly to reverse the direction of the stream of energy and to make them converge upon the "self." The old person, it is true, does rather incline to be over-credulous, like a child, or to be unduly impressed with whatsoever savors of the marvellous; but this difference is to be noted: the credulity of youth is generally self-forgetful with impersonal motives, whereas the old person is constantly feeding upon his personal "memories of better times." His standpoint is restricted to his own experience: fifty years ago life was simpler; people were less ambitious and were satisfied with what they had. Discipline, we are assured, was enforced in schools and boys were compelled to learn their lessons. There were fewer newspapers and most of these were well edited, the leading editorials a contrast to what is printed to-day. The reason for such remembrances we seldom mark; they are not uttered primarily to impress an audience, but rather to strengthen home-defenses.

\* Leopold, L., *Prestige, a Psychologic Study of Social Estimates* (Fisher Unwin, London, Leipzig, 1913).

The halo of prestige is also used as compensation by the aged for curtailment of the adjusting capacity. To follow this extremely interesting field of study we need to go into all walks of life and among all races of men. For a better comprehension of senile propensities we also need to establish a basis of normality through familiarity with a great range of conditions and knowledge of the forces which early in life stimulate the imagination, arouse enthusiasm, and command admiration. With this information at our command we should form an idea of the importance attached, during old age to distinctions created by authority, or the pretense of contempt for physical labor as compared with intellectual effort. A more or less neutral sentiment in regard to prestige may be transformed in a most subtle manner into a decided and unfortunate prejudice; and such a transformation frequently denotes the onset of old age.

The ignorance of some of the most ardent but least rational supporters of democracy in regard to the biologic sources responsible for a desire for and gratification in prestige has led to serious blunders in attempts to make satisfactory social adjustments or to direct the organization of political life. We may be quite ready to admit that prestige is "the curse of greatness" and the stumbling-block in the road of social progress, but we have hitherto closed our eyes to the universal prevalence of the elements from which this sentiment springs. In the present state of society we need to make great allowance for this weakness and admit the fact that there are some compensations associated with the foibles of human nature. The danger lies, not in making concessions to what may be called the rational claims of distinction and prestige, but in blindly ignoring these states of mind and in repressing all impulses connected with them until for the restoration of equilibrium an explosion is necessary.

Marked eccentricities of behavior during involution should be regarded as indicative of progressive changes taking place within the central nervous system and are symptoms of pathologic significance. There may be, of course, vary-

ing degrees of aggressiveness marking the exaggeration of the ego. Sometimes amusing eccentricities may develop from the displacements of self. The person may be quixotic in action, or he may strive to hold the centre of interest to a degree to excite ridicule. The Beau Brummel type offers an illustration of this propensity to secure attention at any cost. All these vagaries may be amusing, but when they are associated with great intellectual capacity many highly unpleasant qualities may be thrown into relief. This at times reaches to the point of intellectual dishonesty which is concealed by a certain show of logic, while every means is used to hide the growing incapacity for coherent and consistent thinking. The haze of mysticism then developing prevents any sympathy with those engaged in the patient and arduous search for truth. The aged mystic revels in speculation, and dialectics engage his ill-directed energy; and moreover, in his fight to maintain fictitious dignity, tradition, customs, and manners are all violated and the personality may become noisy and obtrusive.

There are also certain signs of old age, decidedly less pathologic in character, which, because of their connection with ordinary physiologic adaptations at this period, merit our attention. We refer to those phenomena that are the changes in the field of consciousness attended by the limitations imposed by voluntary movements; but as yet these relations have had only casual study. We know that in the period of growth the adaptations occurring in the higher levels multiply rapidly as the co-ordination and linking up of movements develop. An example of the marvellous extension of the field of adaptation in muscular systems may be found in any one of several actions—swimming, riding horseback, or playing golf. We do not think often enough of the effect upon the personality involved in the successful linking up of these systems through which uniform and co-ordinate reactions result. Nor do we realize that the converse is true when the dropping off of these responses involves lessening of co-ordination and movement. So also the interference of one set of movements makes in-

compatible certain other responses by breaking up the system. These curtailings of the associative dispositions must have bearing upon the old-age adjustments of the personality. For example: the breaking down of the movement system has, we know, a decided effect upon such primitive adjustments as instincts and the less complicated habits.\* Interference, too, with the conduction of sensory impressions is probably productive of change in the associated dispositions. The "recency factor," or the readiness shown by a nerve tract to renew its discharge is likely to be interfered with by the body changes. These motor dispositions are known to be closely connected with the process of recognition, so that it is not improbable that the alteration in these mechanisms during old age has much significance in the disturbances of memory at this period.

Other indications of the onset of old age may be noted even by the layman. Such, for instance, is the unwillingness to effect a compromise; also old beliefs are held with greatest tenacity, and convictions expressed that are suggestive of a failing pliability. There is also to be remarked a tendency to pay less deference to the views of other persons, although we are at times deceived by a superficial acquiescence in them. Discussion of any subject is apt to induce at one time obsequiousness and at another arrogance. Or again—a proposition is no longer considered as a single term in a complicated series, while the earnestness with which conviction is expressed may be entirely out of proportion to the possibility of error. Old age does not acquiesce readily to public opinion and an attempt to gain assent is often the occasion of opposition both petulant and acrimonious. The strength of the conviction may not lessen, although there may be marked lethargy if execution is demanded. Indeed, the expression of the fervid spirit may hide the diminishing wish to act. As time goes on these convictions are subordinated to the desire for physical comfort, and the routine of life is directly influenced by the

\* Washburn, M. F., *Movement and Imagery* (Houghton, Mifflin Co., Boston, 1916).

petty environmental conditions which once seemed to produce little effect. This is not due to increased sensitivity, but to the removal of inhibition. Stimuli of a minor nature, especially annoying ones, now have immediate effects, whereas once they were allowed to pass without remark. Some of these mental states, we observe, seem at first to reflect strange paradoxes, but close examination will demonstrate that they are reducible to a common basis.

Some acquaintance with the more pronounced mental symptoms of senility is useful in throwing light on the complex mental attitudes developing after the prime of life has passed. The inability to adapt life to meet changed conditions we find in a variety of ways, from a definite inclination to be old-fashioned, accompanied often by charm and a certain gracefulness artfully employed to conceal the disinclination to move with the times, to a personality bristling with whimsicalities and oddness distressing to relatives and friends. Most of us are familiar with the resentment displayed by old people when they think themselves slighted. This disposition may be revealed with the discharge of ordinary social amenities, or it may arise without apparent provocation and rapidly develop the characteristics associated with obsessions and fixed ideas. Again, the instability of the emotional life may lead to an abnormal degree of suggestibility resulting in erratic judgments making the aged person peculiarly liable to accept various false statements, or be subject to impositions without exercising any real discrimination.

We need not go into any further detail in connection with these signs of mental deterioration; these will be found in medical text-books. But we do wish to lay emphasis upon the fact that the differential diagnosis between what may be called a normal old age and conditions recognized as symptoms of disease must require an extensive acquaintance with the qualities of temperament and character shown by the person under examination during preceding periods of life.

## CHAPTER XI

### IMPERFECT ORGANIZATION OF ACTIVITIES

#### (CONFLICT AND DISSOCIATION OF THE PERSONALITY)

EVERY living organism is continually engaged in manufacturing, storing, and releasing energy, as well as providing for the elimination of waste products. These two groups of functions may be interfered with by conditions either within the organism or in the environment. Derangement of function, whether the cause is intrinsic or extrinsic, is registered in the depreciation of the delicately balanced and complicated functions by which the organism maintains contact with the environment. Interference with these functions reduces the efficiency of the organism in the struggle either to protect itself or to insure the perpetuation of the species. In the phenomena of conflict and dissociation we find evidences of the failure to satisfy these two great biologic needs. In the case of the amoeba this reduction in the adaptive capacity is marked by relatively simple disorders of behavior, whereas in man evidences of the disturbance may appear in connection with such exquisitely sensitive emotional and mental adjustments that they may be extremely difficult to recognize.

Countless examples exist to-day of the disastrous effects produced by disorders interfering with the manufacture, storing, and release of energy in disorganizing the entire personality. Changes in the composition of the blood, the result, for example, of hunger, not only impair the neuromuscular activity, but they profoundly alter the normal expression of the sexual life, as well as the form of organization of the higher emotional and intellectual reactions. The conditions now prevailing in many European countries have furnished numerous examples of this relationship. Among children especially the effect of hunger in depriving

them of a sense of joy in living, mirth, and the desire to play is particularly noticeable in regions where the food supply is limited. Physicians visiting Austria have been struck with the number of children gazing in an indolent fashion at what is going on about them, remaining quiet; and giving evidences of excessive fatigue after slight exertion.\* The

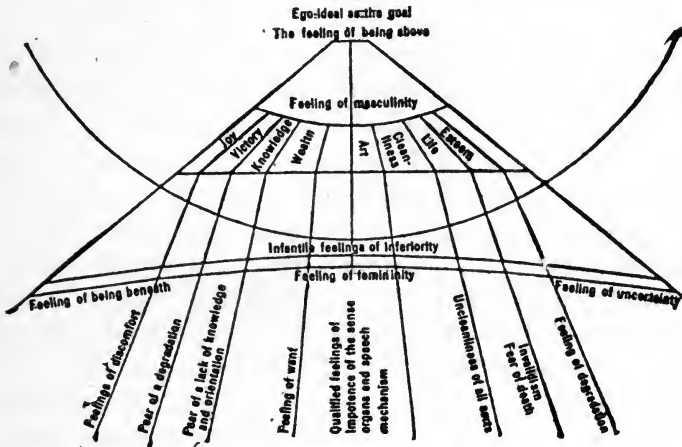

From *The Neurotic Constitution* (translated by Bernard Glueck. Moffat, Yard & Co., New York, 1917). By permission.

nervous system apparently has a relatively high resistance, probably more than the muscular system, to loss of food: whether these symptoms are primarily the result of the reduced efficiency of the muscular or nervous system it is impossible to say. The reduction in the supply of certain mineral salts produces in children abnormal fatigue and excessive excitability. One result of the loss of play instinct is that the coarser and lower instincts soon begin to dominate behavior. Thus the emotional and intellectual adaptations are either improved or rendered less effective by influences affecting the production, reservation, and release of vital energy.

The regulation of the energy supply is practically under the control of the autonomic nervous system. As soon as

\*Thiele u. Lorenz, *Hunger: Wirkungen moderner Kriegsmethoden* (M. Rubner, Berlin). "The Genesis of Mirth," *Lancet*, October 11, 1919, p. 657.

the metabolic changes occur that disturb the physiological balance, or whenever incident environmental stimuli create a need demanding satisfaction, the machinery of adjustment is automatically thrown into action, somewhat in the same manner that the fall in the pressure of water in a tank starts the electric pump to renew the supply. Following the registration by the autonomic system of the immediate needs of the organism the proficient sensori-motor apparatus is called upon to assist in restoring the balance. This is brought about by the influence of the autonomic system upon the receptors, which facilitates a selective discrimination of stimuli, encouraging the action of favorable and useful forms, while rejecting the harmful ones.

In order to understand what forces are at work tending either to assist or to interfere with the integrative activity expressed in the personality we should remember that the conscious adaptations register the unity of action of the working body; and this registration embraces a great variety of functions—heart, lungs, organs of internal secretions, etc.—all tending when there is harmonious adjustment to preserve the unity expressed in consciousness, but whenever the function of any one part is seriously impaired or rendered defective, dissociation begins. If the normal tonus of any organ or group of organs is either increased or lowered, the effect upon the behavior of the entire organism may be and often is indicated. Under these conditions, if the situation under which the organism finds itself is not too difficult, the reinforcement of useful and the rejection of harmful stimuli proceed under autonomic direction until the physiological balance is again restored. In a preceding chapter we have noted that the process of adaptation includes two sets of reactions: one group preserves the unity while the other represents the tendencies of the functions of different parts to assert themselves. Dissociation begins as soon as the resistance to unified activity is increased by any of the parts.

In certain ways the machinery of adjustment in the human organism is not unlike that of an electric power plant



with its lines of distributing wires for lighting and other purposes. There is a constant flow of energy through the main cables supplying the drive for various needs, including the lighting system,—representing the conscious processes. Fluctuations of the current will be quickly reflected in the rise or fall of the lights, while a sudden increase of the flow may result in blowing out the transformer, rendering the entire lighting system useless.

We have also already remarked upon two of the functions of man's new brain, namely, to act as a transformer of the impulses streaming up from the old brain, and to hold these in check long enough to insure proper arrangement for the distribution of energy without throwing too much energy into one channel. As the brain and nervous system developed, the centres for the older primitive protopathic sensory apparatus and stereotyped instinctive activities which were located in the basal ganglia, were covered over and reinforced by the complicated new brain or cerebral cortex. The addition of these areas with their so-called higher functions greatly extended the range of adaptation by utilizing consciousness. Under the old régime adaptation unattended by any sense of the perspective of events was sufficient to satisfy actual conditions, but with the extraordinary increased complexity of the integrations made possible by consciousness and the intricate epicritic system an entirely new set of functions was called into action. In man there still exists the old apparatus by which primitive instincts found expression, but with the growth of the neo-pallium, the new brain, the co-ordination of conduct and the domination of instinct by intelligence were insured. Another of the functions of this new brain is to couple to behavior ideas of ends or goals to be accomplished, and this is effected by the super-instinctive adjustments associated with the higher forms of intelligence. By these provisions not only the immediate instinctive craving was satisfied, but the machinery of the emotion providing on a much more elaborate scale for the extension of the range of adaptation and the good of the animal was called into operation.

This secondary and so-called higher system drains the pressure from the lower instinctive system and usually provides ample means for the discharge of the increased nervous tension.

Head\* has pointed out that the reduced threshold for stimulation normally associated with the higher centres of the cerebral cortex is usually so low as to give an avenue of discharge when the lower centres of the central nervous system have been stimulated. The mechanisms of the cortex respond more readily than do, for example, "the cumbersome mechanisms of the thalamus region" at the base of the brain. The cerebral cortex supplies the sluiceways by which excessive currents may be drained off and sublimated.

But if any interference exists so that the ordinary channels of discharge are blocked, a conflict with waste of energy is precipitated. Again, in this connection it is important to remember that we have no information justifying the assumption that impulses are either suppressed or repressed. The evidence seems to be that the pressure substituting adjustment in one direction or at one level for that in another comes from below, not above, and is a question of divagation and not one of suppression. This point deserves emphasis for, as we shall see presently, it has an important bearing upon the views of the Freudian School.

When we consider the antiquity and primitive character of the forces which, if not properly directed, promptly lead to thorough disorganization of the personality it is no surprise to find the impulses coming from the muscular system responsible for many of these changes. The thwarted integration of muscular reactions is often expressed in disorders of attention, abnormal feelings, and a curtailed or asymmetrical personality. In this connection it is worth while to consider the thwarted muscular reactions in conditions of fatigue. There seem to be two types or rather two causes of fatigue: one the commoner form, originating within the central nervous system, and the other within the mus-

\* Head, Henry, *Brain*, 1911-12, p. 191.

cular system.\* According to Bainbridge, the effect of muscular activity alone does not result in fatigue of the central nervous system. Severe physical exercise does not produce harmful fatigue in a healthy person, nor serious consequences. In this connection, however, we should think of the results of Mayor's work showing that the muscular system is less resistive to changes in the chemical environment than is the nervous system. The efficient working of the body depends on co-ordination and integration, not only of the functions of the muscular system, but also upon those of the respiratory, circulatory, and other organs. Energy is wasted if there is an exaggerated activity of the respiratory and circulatory system, while a deficient response rapidly lowers the control of the nervous system, interferes with the functions of the muscular system, and ends in ineffective action.

The study of behavior should not stop with the analysis of overt acts, but should cover the factors concerned in giving the set to all activities, particularly to all the important muscular tonus which is so often overlooked or forgotten. The increased or diminished tonus of different parts of the body may easily become a provocative factor in precipitating a conflict. It is also easily comprehensible that a situation with which a person was once able to cope successfully may become intolerable as the result of a diminished capacity to reinforce, expedite, or inhibit movements. The three functions of reinforcement, facilitation, and inhibition of movement are represented in the state of preparedness preliminary to all consummatory reactions that represent a drive toward some definite goal. Failure in these preparatory reactions may quickly lead to disastrous consequences.

The preservation of the organization of the personality depends, to a large extent, upon the participation of the muscular system. The postural tonus of the muscles is the foundation upon which all the integrations from the reflexes to the higher mental processes are established. Interference

\* Bainbridge, F. A., *The Physiology of Muscular Exercise* (Longmans, Green & Co., 1919).

with the stream of kinesthetic impressions, some of them never reaching consciousness while others are well within its foreground, may lead quickly to a rapid and complete dissociation. The muscular tonus and the muscular contractions are so closely associated with the emotional reactions that they give the set to all the higher intellectual adjustments. It has been well said that "we think with our muscles," and when there is evidence of disorganized thought processes the changes are often registered in postural attitudes, as well as in the character of the co-ordination and integration of muscular reactions.

There are certain points connected with the transfer of authority from the old to the new brain that deserve special consideration on account of their bearing on dissociation. The old brain contains the machinery for regulating the instinctive life which is expressed in immediate unmodifiable reactions in response to stimuli determined by congenital predispositions of the nervous system. These reactions are unattended by a sense of perspective, and recur irrespective either of the teachings of experience or without reference to future events. When the secondary system, including the epicritic sensory apparatus, is laid down, functions supplementing the fixed undeviable instinctive reactions are brought into play. It is essential that this secondary system should "fit" the primary one, because if it does not the harmony required for the normal and complete development of the personality is sacrificed. One of the chief functions of the secondary system is to facilitate the full and free expression of the deep-seated instinctive life, making it easy for an instinct to be linked to sentiments, ideas, and to be discharged in action.

If random impulses unrelated to the general synthesis of activities block the road for expression of instincts, the result is comparable to what would happen were a slow-moving freight train to be allowed to jog along ahead of an express.

From the great field of unconscious memories impulses are continually surging to the front, and for them lines of free

communication with the external world must be supplied. If the stream meets with resistance the conflict begins. The secondary system, to a large extent, supersedes and supplements, but does not suppress or repress the function of the old brain. Very often, after a sudden insurrection of the old instinctive life,\* impulses may shatter the lines of recently acquired associations of the new brain. There does not seem to be any basis for assuming that the higher forms of association are ever either suppressed or repressed, but they may be choked or held in abeyance by insurgent forces operating from lower levels. The upward drive of primitive instincts may not only lead to disharmony, but even slight deficiency in the correlation of sense-impressions may also give rise to a sense of incompleteness. There may be an extremely annoying sense of dissociation present if the fragmentariness incident to normal sense-perception† is not remedied by the welding forces resident in the brain. It is not improbable that interference with the functions of sense-perception, such as occurs in epilepsy, is the basis of the terrifying sensations so characteristic of the prodromal stages of the attacks. Countless impressions are stamped upon the organism and relatively few of these filter through to the conscious field. An increased resistance, or, as Freud has called it, a censorship, is established, and new outlets for the drive must be found.

Many explanations suggested for the method by which the resistance is interposed and a discrimination unfavorable to the passage of certain impulses is brought about, are purely hypothetical. As has been stated already, we can only reason from analogy and draw inferences from the few facts known in regard to the volitional processes. Most of the unconscious material never rises to the conscious level. Frequently the material which finds its way into consciousness is side-tracked and replaced. A tendency to a certain line of action, an interest, a capacity, and an idea may be

\* Read, C., "The Unconscious," *Brit. J. Psychol.*, 1919, IX, parts 3-4, p. 281.

† Laird, John, "The Psychological Interpretation of Sense Data," *Brit. J. Psychol.*, 1919, vol. IX, parts 3-4, p. 262.

replaced by some symbol marking the transfer.\* In this connection, as Jones points out, it is worth noting that, as the mind develops or expands, the transference of interest and understanding from simpler to more complex ideas may be marked by symbols. The substitution of a symbol indicates either such a defective apprehension or difficulty in presentation that there is a reversion to a simpler type of mental process. In cases where the regression has not proceeded too far a metaphor is adopted as a means of expression, and a name or descriptive term is applied to an object not literally fitting the description. The richness of symbolism in all languages relating to the sexual functions is one result of the repressions imposed by civilization.

The tendency to symbolize is associated with a defect in the apperceptive process, so that ideas or qualities of objects are not clearly distinguished. In states of fatigue the inclination to resort to symbolization is often very marked. In dreams also this tendency is still further exaggerated. Symbolization compensates for the difficulty of either apprehending or presenting the ideas to consciousness. Freud has called attention to the similarity between these forms of symbolism and those of an ancient language which has almost disappeared.

The extraordinary ubiquity of symbolization indicates that it is one indication of adjusting to meet a difficult situation by dropping back to a lower level. Considered in its broadest sense, symbolism, according to Jones, is the replacement of one idea, interest, capacity, or tendency by another. The importance of this form of adjustment is brought out in analyzing the processes taking place in connection with the genesis of the mind. The actual gains do not seem to be due to mere accretions so much as to the various transfers concerned in connection with the ideas, interests, capacities, and tendencies, as well as to the uncovering of old symbols once rejected by the personality

\* Jones, Ernest, *Brit. J. Psychol.*, 1919, IX, part 2, p. 181. Silberer, H., "The Problems of Mysticism and Its Symbolism" (translated by S. E. Jelliffe); Schlesinger, M., "The History of the Symbol" (translated by S. E. Jelliffe and Louis Brink), *J. Neu. and Mental Disease*, 1920, LI.

when the emotional or intellectual state was not favorable for their acceptance.

Symbols as a rule are made use of to present ideas relating to subjects which are the closest to us and of the most vital importance; including ideas relating to self, life, birth, love, and death. Their significance can only be appreciated by observing what goes on in the background of the personality. The regression to a lower level of apprehension may also range over wide limits. If the process is relatively restricted a metaphorical symbolism is the result, but if the resistance is greatly increased there is a genuine symbolism. In the use of the simile there is, for example, a regression to a still more primitive method of expression.

Jones has given an excellent summary of the chief attributes of the symbol. (1) It is both concrete and sensorial, in contrast to the abstractness and complexity of the idea for which it is substituted; (2) is more primitive in character; (3) represents an idea which is more or less difficult of apprehension; and (4) the forces prompting its use are to a large extent subconscious.

The language of unconscious gesture\* represents the deep-seated tendencies that are always pressing forward to find expression. The general set of the body, the customary attitudes, the usual gestures, the slight changes in the play of facial muscles, the impediments of speech, the hesitancy of manner are generally excellent indications of what is going on in the back of a person's head. The first sign of conflict is often apparent in the evident contradiction between these motor adjustments influenced by the real moving forces and the counterfeits presented by the conscious processes, in the effort to conceal evidences of defects in the structure of the personality.

We have an interesting illustration of the use of symbolism to compensate for a defect in apprehension in the so-called body-mind problem. Man has always emphasized the apparent contrasts existing between physical and

\* Nicoll, Maurice, *Dream Psychology* (Oxford University Press, London, 1917).

spiritual phenomena and personified "the man within" as quite distinct from "the man without." This personification of the inner man is probably due to the fact that the brain and spinal cord, not having receptors, furnish no information directly to their possessor of just what is going on in them. Man cannot react discriminately to what is going on in his own head, and therefore is actually better informed about the environment than in regard to his own cerebral processes, and consequently he personifies the mechanisms about which he has no first-hand information.\* This kind of reaction illustrates an important principle applicable in explaining many mental attitudes. Whenever man is confronted with a perplexing and dangerous situation the effort to personify the events tends to restore stability by the act of concentration, at least temporarily, on a definite undertaking. The vagueness and indefinite character of many experiences are in themselves a disturbing element, and anything that gives definiteness to the problem awaiting solution at the same time brings both courage and conviction. If civilized man is suddenly confronted with a critical and terrifying experience the situation to be met is often pictured in symbols. This process is a reversion to the means and method practised by our primitive ancestors and is an attempt to reinforce the weakened sense of personality by a symbol supposed to possess apotropaic qualities. Symbolism marks a divarication in the stream of energy flowing through the personality. Consequently currents forcing themselves to the fore from the lower levels call for the use of more primitive methods of expression.

The careful analysis of the causes leading to the use of symbols brings out the fact that the elements are present which may easily lead to a conflict, since there is a definite antagonism between impulses backed up by the instinctive drive. Much should be accomplished by further investigations in this direction, particularly as to situations in

\* Weiss, A. P., "The Mind and the Man Within," *Psy. Rev.*, 1919, XXVI, no. 5.



which the use of symbols results either in a definite sense of satisfaction or a distinct feeling of relief from increased tension. The dissociation tendencies in exaggerated symbolism are marked by a reduced capacity for apprehension and presentation, but probably there are also other important factors to be taken into account.

Our knowledge of the synthetic as well as the dissociative processes is based upon information relating to the fundamental functions of reinforcement, facilitation, and the checking or inhibition of reactions. The organism has a definite "set" toward the environment. An impulse to react is liberated, and this is quickly strengthened and other responses are linked up with it, or it is inhibited and either diminishes in force or entirely dies away.

If the "set" and the preparatory reactions which result in a genuine state of preparedness to meet reality lead directly to consummatory responses indicating that difficulties have been successfully met and surmounted, then a feeling of satisfaction and a reward in the sense of accomplishment follows. Woodworth has pointed out that the interest for continuing the drive and insuring free and effective performance is inherent in the activity. If this force fails the customary and anticipated reward will not be attained.

Stopping short of the goal of actual performance has a deleterious effect. The entire personality is built upon a system of natural rewards and promises. One act successfully executed not only creates a sense of satisfaction, but prepares the person to face anticipated events with confidence. Few persons appreciate the value of achievement. Whenever the opportunity is not presented to sense it, the organization of the personality is endangered. If the recognition of this principle were made the basis of the educational system, there would be less misery in the world and the progress of civilization would be quickened. In states of fatigue there is an excellent opportunity to note the effect of a diminished feeling of adequacy. Mutual suspicion of employer and employee, which is having in many instances

such a disastrous effect in the industrial world, is due to the unwillingness of the former to provide the conditions creating in the working man the feeling that he has actually done a good job; while, on the other hand, the laborer himself fails to appreciate the value of the sense of gratification associated with a task well and thoroughly done.

When a man works and is able to rise to the occasion so as to become thoroughly efficient, his range of interests constantly broadens and in the literal and best sense he becomes independent. One, but by no means the only, source of gratification in this expansion of interests, is the associated sense of authority which is derived from the effective prosecution of any task. Possibly Adler\* has over-emphasized the importance of this feeling of authority, but, unless this instinctive craving for mastery is gratified, the personality is stunted and fundamental needs of the organism are thwarted. There is something within every man reminding him of the fact that life is a struggle for existence and many of the tragedies in the world are the result of efforts to disguise or hide this truth. The consequences of occupying any position where unexpressed needs are smothered and interests are not given an opportunity to be realized are made dramatically apparent in the life of almost every individual.

The cases of staleness occurring among industrial workers illustrate the far-reaching consequences of maladjustments. Staleness starves interest and obstructs the free expression of instincts. This is obvious in states of fatigue. The lack of interest and peculiar emotional irritability accompanying excessive fatigue are easily recognized qualities.

Six aviators once came under the observation of the writer, who, although with excellent records in the Air Service, gave evidences of diminished interest in work, of emotional irritability, and of a decreased feeling of competency, which

\* Adler, A., *Die Bedeutung d. Organminderwertigkeitslehre f. Philosophie u. Psychologie*, Vortrag in d. Gesellschaft f. Philosophie an der Universität in Wien, 1908. *The Neurotic Constitution* (translated by Bernard Glueck; Moffat, Yard & Co., New York, 1917). *Ferenz's Contributions to Psycho-Analysis* (translated by E. Jones; Badger, Boston, 1916).

marked a condition of staleness. The recommendation that these men should not be allowed to fly until they had rested was not adopted, with the result that within forty-eight hours four of the six pilots had crashed to earth, fortunately, however, without sustaining any severe injuries, although their machines were wrecked.

In connection with the question of industrial and mechanical efficiency there are excellent opportunities to investigate the factors contributing to the sense of adequacy and feeling of self-reliance, which are responsible for a rational belief in individual competency. The sharpness of attention, precision of motor co-ordination, as well as the desire to work are often greatly reduced because of fatigue. This kind of dissociation is often evident.\* Attention has been called by the report of the Ohio Industrial Commission (Report No. 4, 1914), to the disorganizing effect of fatigue upon the personality, as well as the recuperation following rest and food. The first subjective sign of a beginning dissociation is generally marked by an arrest of active interest. Experienced aviators not infrequently complain that they do not know why their interest in flying is suddenly curtailed, with, to them, unaccountable indifference to their fate. Other aviators, instead of indifference, develop a marked irritability and abnormal anxiety. Fatigue lays bare the deep-seated tendencies and temperamental qualities characteristic of the personality. The personal equation has an immense effect in determining the character of reactions to a subjective sense of inadequacy, induced by fatigue or other causes.

More attention should be devoted, first, to the analysis of the symptoms, both objective and subjective, of states of inadequacy, and then to careful notes upon the subsequent responses taking place as soon as a person becomes conscious of self-insufficiency.

The adequacy complex is so very close to the core of the personality that it would be difficult to overestimate the

\* Lee, Frederick S., *The Human Machine and Industrial Efficiency* (Longmans, Green & Co., New York, 1919).

importance of the rôle this plays either in extending or limiting the range of the integrative processes. Around this nucleus gather a great mass of emotions and chains of ideas which cannot be upset without seriously deranging the organization of the personality. The sense of sufficiency, of being equal to the task, tends to kindle new interests in life, and also calls for an increased number of points of contact with reality. The great complexity of feeling of adequacy is due to the fact that it not only includes memories of the results of situations encountered and mastered, but it has a direct bearing upon anticipated events. The plan for living adopted by the individual is inseparably bound up with this group of complex sensations.

If a situation is encountered with which a person cannot cope successfully, two lines of action are open. The insuperable character of the difficulty may be promptly recognized and a satisfactory readjustment may be effected at a lower level. This is the sane and wise course to follow. Another procedure, however, very frequently is adopted. As the sense of inadequacy develops efforts are made to suppress it; this undertaking generally turns out to be much more extensive than was anticipated. Or if the insufficiency be ignored it crops up at unexpected moments and often presents its claims in so embarrassing a manner as to demand attention.

The dissociation responsible for the emotional and mental processes leading to the development of egotism affects the experiences from which the sense of personal identity is compounded.\* The first mental readjustment in the complex of egotism is the effort to effect some kind of reparation to offset the recollection of ineffectuality in connection with past or present experiences. Unfortunately, the dissatisfaction of the egotist with the actual facts of life, and particularly with self, is extreme. Balked in the attempt to forget and obliterate traces of inadequacy, the egotist resorts either to magic or force, or both, to create new and

\* Warren, Howard P., *Human Psychology*, p. 385 (Houghton, Mifflin Co., 1919).

imaginary situations in which the impaired sense of authority is vindicated. Egotism is a protest; and one cannot with impunity become a chronic protester. Protestation encourages instability and a tendency to abandon logic and to attempt to realize some purpose by an advertised short cut.

The apparent sincerity of the idealism of many egotists should not blind us to the dangerous forces in their personality. It is only too easy for an egotist\* to mistake his passions for duties and his cupidities for his desires. Such a person may furnish a wonderful example of devotion to a certain kind of idealism, but the great danger lies in the fact that his entire conduct of life is built upon a series of impressions which careful scrutiny reveals to be the product of unsatisfied personal ambitions and irrational impulses. The egotist, therefore, is very anxious to have other people face reality while he turns his back upon it. There is no limit to which this method of striving to secure a satisfactory readjustment may not be carried, if the intellectual activities are once fully enlisted in the effort to conceal the basic defect.

When the causes of the war are studied it will probably become more and more apparent that the real driving force in German temperament and character leading to the invasion of Belgium and the sinking of the *Lusitania* was egotism. The egotist, as Santayana has reminded us, like a bull may come to trust so implicitly "in his own strength, rage, and courage" that he follows "a little red flag and his destiny this way and that way," without respect or consideration for the rights of others.

The chief danger in egotism is that it encourages precipitate impulsive action. An intelligent egotist may for a long period of time confine his activities to carrying on a parlor campaign in favor of Bolshevism. He may say a good deal that is both interesting and pertinent upon the subject of sham ideals and the general brotherhood of man. But

\* Santayana, G., *Egotism in German Philosophy* (J. M. Dent & Company, London and Toronto; Charles Scribner's Sons, New York, 1914).

sooner or later he becomes intemperate and is forced to resort to any available means and methods for preserving his super-ideals. The fact that the egotist prefers what he calls "impersonal" ideals does not improve the situation. The impersonal ideals, which are often mere humbug, take the place of annoying and irritating personal recollections. A dramatic declaration of interest in public morality often replaces the recollection of personal mortification. When a glimpse of the real self behind the screen is once obtained the curtain is very quickly drawn, and then the amount of rational thinking and acting depends entirely upon the time and energy remaining after the struggle to keep the inadequate personality hidden has become less intense. It is literally true that the egotist is capable of splitting heads as well as hairs in the effort to conceal self-insufficiency. At times the poses assumed are amusing, while his extraordinary impertinences may be exceedingly irritating, and the absolute self-assertion as vindictive as Prussian or Bolshevik autocracy can make it.

The impersonal manner in which ideas are often formulated is neither a safe nor a sane means of testing either their elevation or practical value. As a matter of fact, "impersonal or ideal aims are not less delusive or higher than personal ones," but, as Santayana says, "there is far more likelihood that they are conventional humbug." The man who is called upon to defend his weakened sense of personality is only too anxious to have his ideals, as well as arguments, put in an impersonal form.

It is often interesting to observe the scientific mind trained to take cognizance only of the facts of experience eagerly clutch at some transcendental scheme for curing the evils of modern civilization. A considerable number of modern scientists and academicians have, unfortunately, copied some of the emotional and mental reactions that in the middle ages drove men into monasteries, with the result that, when they are unexpectedly called upon to come into close touch with the actual world, they commit the error of attempting to adjust their lives, not to reality but to an ar-

tificially wish-constructed environment. One of the first steps in this direction is the impersonalization of ideals. The mere fact of impersonalization makes it more difficult to detect the genuine from the false, and sometimes the differences are not noted in time to prevent a catastrophe. An idealism formulated or expressed in a censorious manner is evidence of dissociation. An irritable idealist may become a menace to the comfort and safety of the community. A censorious tendency under slight provocation may become haughty arrogance. The egotist enjoys teaching, but not learning, and he is always exceedingly careful to announce the names upon whom he believes retributive justice will fall. The egotist is generally aggressive, but he may also be exceedingly docile when engaged in any enterprise in which attention is directed away from his inadequacy.\* The example of the German probably is the most striking one we possess. Their egotism was both organized and deficient in a sense of humor, and finally became so dogmatic that imaginative sympathy was suppressed until the sense of perspective was entirely lost and delusions were formed.

The longer the egotism persists and the greater the intellectual power involved in the process becomes, the greater is the display of selfishness. As the egotist has very decided reasons for not wishing to face a world of reality he is easily induced to become an enthusiast in chasing shadows. It does not make any difference what his vocation is, whether scientific, artistic, literary, or trading, his reactions against reality are often extraordinarily intense and prolonged. The fact that he is an announced realist in art, literature, or science does not alter the case. He may be scrupulously accurate in writing mathematical formulæ, and execute with precision some copy of nature as he sees it, but, when not working, his rebellion against the actual conditions and practices of the present may become a form of mania. Rebellion against reality, against social injustice, against

\* Holmes, E., *The Nemesis of Docility, a Study of German Character* (E. P. Dutton & Company, New York).

the tyranny of mediocrity, against the enemies of the people, are sentiments thrown up like clouds of dust to hide the real self, which so often is an embarrassing reminder of weakened prestige. The form of dissociation expressed in egotism is dangerous, because so many powerful trends are repressed and held in check by mechanisms that tend to encourage the accumulation of strong forces that when these are unexpectedly liberated they destroy whatever opposes them.

Of course we should not expect to find one single cause operating to produce dissociation. Sometimes the chief source seems to be in the person's environment and at others is within himself, but both sets of factors should always be taken into account. The personality, no less than life, depends upon the relation of external and internal conditions. Imperfect adjustments in environmental relations may supply the straw to break the balance and induce dissociation of the personality as quickly as any disorder of the individual's internal arrangements. We have an excellent illustration of the extreme delicacy of balance and the ease with which this is upset by poor environmental contacts in the reactions of hypersensitive persons entering a passenger elevator. Generally the personality is adjusted to meet the requirements of a certain visual range, and, because this is suddenly reduced to narrow limits, there is a reaction decidedly disconcerting to the neurotic person, whose "self-feeling" comes instantly into prominence. Embarrassment is felt when "in the close proximity of other passengers there is no place to direct one's gaze." For a few seconds, as a result of limitation of the range of visual adaptability to the narrow limits of the lift, there may be a good deal of mental confusion, particularly in those cases where distractibility is a prominent characteristic of the personality. The emotional balance is adjusted to reinforce impulses and interests at a certain range, but is upset by the close quarters of the lift. In this simple experience we have an excellent test for the stability of the personality complex. The phlegmatic type, or the person who,



only after repeated stimulations, shows signs of intense reactions along a few lines is not so easily deprived of the ordinary sense of comfortable adjustment. Very nervous persons complain that when they enter a lift and the attendant closes the door they become ill at ease. Even persons who generally pass as normal, and to outward appearance are not particularly nervous, experience a change in their personality under such conditions. In order to understand these reactions we should remember that nervousness is evidence of imperfect environmental adjustment, and persons in this condition soon establish a series of imperfect compensatory reactions which are easily thrown out of gear and produce decided discomfort as the consequence of placing limitations upon the ordinary range of visual adaptation. Under ordinary circumstances social intercourse is not carried on at such a short range as is imposed by the narrow confines of the lift and the emotional balance may be quickly disturbed by the compulsion to adjust life, even for a few moments, to a restricted environment.

Under normal conditions the higher levels of activity represented by thought and volitional responses have frequently acquired—largely as the result of traditional conceptions—such an aloofness and such a degree of individualistic distinction that their relations to physical processes and to the biologic unity are lost sight of. When, however, there is any pronounced dissociation of the personality, as in an attack of mental disease, then the adjustments at the higher seem to be so closely related to those at the lower levels that the close interrelation of the different forms of adaptation is taken for granted. On the other hand, when normal conditions prevail, we are not so apt to appreciate the full significance of Herbert Spencer's statement that "mind is not as deep as the brain only, but in a sense as deep as the viscera." In nature's analysis of disease the connecting links between the various physical and mental levels are often exposed, particularly when the dependence of the intellectual upon the emotional responses is accentuated, as it often is during a psycho-neurosis.

The relation of internal to external factors is illustrated by the following extracts from the history of a case, which show how the angle of approach determines the attitude toward the body-mind problem, and bring out the fact that studies carried on in the clinic in completing an analysis of the personality are less apt to emphasize artificial distinctions than are the reflections of the academic psychologist.

A young man often complained of a sense of inadequacy in facing difficult situations. In addition to the general subjective symptoms, there were local objective symptoms. He was nearly six feet in height, had clear-cut, sharp features, deep bass voice, and slight hypermetropia suggesting the high thyroid type. His reflexes, both superficial and deep, were very active, and there was a slight tremor of the extremities which was increased by drinking coffee. A study of the metabolic processes indicated that they were above normal. The extreme sensitivity undoubtedly intensified the effect of the dynamic affectivity upon the entire personality, giving rise to considerable dissociation.

Although interested in the manual training essential in the preparation for his profession, he complained of weakness and inability to co-ordinate the finer movements requisite for drawing or working with tools. The coarser movements requiring strength were not difficult for him, but it was noticed that as soon as the attention was focussed upon any occupation demanding skill there was sudden exacerbation of the feeling of fatigue and of weakness in the right hand and arm. Careful examination failed to find positive evidence of reduced muscular strength in this limb or any serious loss of the co-ordinating capacity. These symptoms of being unequal to the task became the nuclei about which others were grouped. In addition to the subjective feeling of exhaustion and the idea of impaired muscular strength in one arm, there was often considerable mental depression and a consciousness, which preyed heavily on his mind, of incapacity in all critical situations. The inclination to work

diminished until finally almost any suggestion of exertion became repellent. At times the feeling of fatigue was localized, sometimes being referred to the head or eyes and at other periods becoming general. When compelled to act during the height of his indisposition he was often seized with marked trembling and was thrown into a state of anxiety.

In contrast to this type of case the intellectual activities of a normal, vigorous man are varied and complex. The machine in the latter case runs so smoothly, however, that some persons are impressed with the apparent detachment of subjective reactions from physiologic processes; and this misconception is due to focussing the attention too exclusively upon special aspects of the personality. The very perfection of the mechanism hides the connecting links. As a rule the disorganization of activities in the lower levels is recognized promptly as the result of some physical cause, but it often happens that quite another set of causes must be sought for in order to explain what takes place.

The extraordinary propelling force exerted by feeling in the effort to effect compensation for inadequacy, puts a person out of contact with reason; and this sejunction is illustrated by the form in which many of our beliefs are cast. These are, ordinarily, quickly removed from the position where they can be carefully scrutinized and are made inaccessible to any attempt to rationalize them. Under the influence of emotion a withdrawal is made from a position which, if held, would require the sacrifice of a sense of adequacy and a feeling of comfortable reassurance. When the first line of defense is abandoned, if defeat is not promptly admitted, an explanation not damaging to the personal sense of pride is demanded. The real trouble begins as soon as the emotions, and not reason, suggest the means for defense. In order to distract attention from the real weakness, an extremely positive statement is made, and the still, small voice of reason is temporarily hushed.

Great stubbornness is usually a sign of weakness in defense. We often meet with persons who make a great show of strength and feign independence, but who adopt a dog-

matic attitude in order to gain some sense of security to compensate for the real weakness and vacillation from which they suffer.

In nearly every form of conflict, so well illustrated by countless incidents in daily life, there is difficulty in picking out the real motives which precipitated the trouble, and therefore the source assigned is not generally the actual cause. For example, A discusses with a friend, B, the problems in which they are both mutually interested. Apparently there is no reason to suspect any conflict, either of motives or interests, but quite unexpectedly considerable feeling is shown by A when B begins to speak with enthusiasm of certain subjects in which he is particularly interested. No reason is apparent why A should resent the mooted of the topics brought to his attention, but he does, and assumes an aggressive attitude, denouncing B's views as thoroughly unsound. Before many minutes the two friends are in active opposition and a series of emotional reactions have occurred which makes any kind of agreement upon the points under discussion impossible. Later the fact is made clear that A was not, in reality, opposed to the opinions expressed by B, but the vehemence with which the latter's views were attacked expressed the disappointment induced by the suppressed memory of unpleasant and strained relations with a third person a short time before this incident occurred.

As already intimated, the members of the so-called Psycho-Analytic School, under the leadership of Freud, have attempted to demonstrate that the sexual life of a person is the nucleus about which all other mechanisms of adjustment are grouped; and that therefore the integrity of the entire synthesis of the personality depends upon the cohesive or disruptive tendencies inherent in these particular functions. The controversy in regard to the dominance of the sexual functions is largely the result of an effort to define processes about which relatively little is known. In many instances the lure of words and phrases—"libido," "complex," "sexual origin," "repression," etc.,—has increased the difficulty of

even formulating the problems for investigation. It is very hard to take such a word as sexual, which generally connotes functions commonly supposed to develop at a considerable period after birth, and adapt the meaning to include responses occurring, not only at birth but during the embryonic period. As soon as we abandon the attempt to seek for rigid definitions we shall—as has often before been the case in the development of the study of human activities—find ourselves in a far better position to interpret the significance of processes which are now only partly understood. So great an importance has recently been attributed to the sexual functions that these reactions, in the minds of some investigators, have been considered as quite detached from all other reactions and little attention is paid to ascertaining their relation to other parts of the personality synthesis.

Freud deserves credit for having redirected attention to the fact that “better the sight of the eyes than the wandering of the desire,” and he has emphasized also the intimate connection existing between the great storehouse of unconscious experiences and the feeling, thoughts, and actions of the individual.\* But both Freud and his students have attributed entirely too much importance to one aspect of a great biologic problem; and it is just this failure that has hampered man repeatedly in his efforts to visualize the problems of human behavior in their correct perspective.

In the large group of symptoms called “shell-shock,” to which attention was directed in a very tragic manner by the war, there were excellent opportunities for studying the drive of primitive instincts and the extraordinarily exclusive forms of reaction unfavorable for promoting integrative activity in connection with emotional attitudes.†

\* Rivers, W. H. R., “Freud’s Psychology of the Unconscious,” *Lancet*, 1917, p. 912.

† Mott, F. W., “War Psycho-Neuroses,” *Lancet*, Jan. 26–Feb. 2, 1918. Rivers, W. H. R., *Lancet*, 1918, p. 173. Kennedy, Foster, “Nervousness in Soldiers,” *J. Amer. Med. Assn.*, 1918, VII, no. 1, p. 22. Salmon, T. W., *The Care and Treatment of Mental Diseases and War Neuroses (Shell-shock) in the British Army* (published by the War Work Committee of the National Committee for Mental Hygiene, 50 Union Square, N. Y.).

It was not from the tremendous excitement alone that so many soldiers developed signs of nervous and mental disorders. The element of suggestion must always be added to the immediate exciting cause. Hysterical symptoms are not induced merely as the result of the effects upon the central nervous system of the explosion of a mine or shell. This fact is quite in accord with what is known in regard to the reactions of the lower organism. Explosions of dynamite sufficiently powerful to kill fish within a radius of forty feet have practically no effect upon the pulsations of jelly-fish.\* The medusæ have a much less concentrated form of nervous system than fish and are without any higher brain centres. Birds are also said to be less susceptible to shock than quadrupeds, and the man with a highly organized intelligence is more liable to suffer from "shell-shock" than the soldier with reduced mental capacity. Probably some of the mechanisms of the cerebral cortex and of the autonomic nervous system are responsible for the "predispositions" favorable to the incidence of shock symptoms.

The recollections of past experiences often lying outside the field of clear consciousness are very important elements in bringing about the signs of dissociation.† A soldier may fight for weeks, even months, without showing any sign of fear or hesitation, but upon his return home may collapse upon the suggestion of going back to the front.‡ Often the man is anxious to get back and do his part, but he nevertheless suddenly finds himself unable to do so. Most of the mechanisms predisposing the mind to face and not dodge the situation are determined by stored experiences. The processes involved in facing any situation are manifold. It may take a long time to find out just which group of all the countless impressions, whether those transmitted from a remote line of ancestors or others recently impressed

\* Mayor, *opus cit.*

† Babinski, J., and Froment, J., *Hystérie-Pithiatisme et troubles nerveux d'ordre réflexe en neurologie de guerre* (Masson & Company, Paris, 1917).

‡ Myers, C. S., "A Final Contribution to the Study of Shell-Shock," *Lancet*, Jan. 11, 1919, p. 51.

upon us by the actual experience of our own lives, is responsible for precipitating the conflict.

In a conflict a feeling of compunction is associated with the compensatory response if the actual symbols used to designate the conditions are not recognized promptly as fictitious; and then a long chain of false values is rapidly built up. When this happens the actual guiding motives in living are the product of an unsuccessful attempt at adjustment; and these new influences and general trends give their stamp to character. The series of reactions recurring during the course of a neurosis or psychosis represent the best efforts of which a person, under these conditions, is capable in the attempt to readjust without assistance his personality to the imperative demands made by the environment. A neurotic patient is constantly dominated by a strict adherence to some plan of living that has been forced upon his attention and controls it without making rational provision for critical situations or for possibilities capable of being actually realized.

In the following notes, taken from a well-known biography, it is interesting to see the origin and development of the same dangerous undercurrents which undermine the personality in cases of "shell-shock." In this particular case of a woman, any reference to childhood days was usually sufficient to call up a flood of recollections of vague feelings of discomfort and a general sense of being ill at ease and a misfit. Even at a very early period there was a spirit of discontent with many of the conventionalities of life. At first there was no inclination to rebel openly against these but merely to endure them in a spirit of meek resignation, while admitting the possibility of their being a necessary part of every-day life. At the time these disturbances first occurred there was not, of course, any definite appreciation by the subject of the rôle extreme hypersensitiveness played in the production of the phenomena. The efforts at rationalization and recognition of the sources of the trouble came much later. The first attempts at re-establishment of equilibrium appeared at a very early period and consisted

of various efforts to explain or justify behavior; but these actions were aimed to secure quick relief and to get rid of the feeling of insecurity. If the possibility of an accident flashed into the mind, immediately the desire to perform some heroic act filled the imagination. Later, as the emotional reactions became conventionalized, to insure the ready acceptance of traditional religious views, the thought occurred of the gratification, as well as the satisfaction, to be experienced by rushing into the flames and saving some article of furniture from a burning church. All budding activities not tending to take part in the expression of accepted conventional views were firmly repressed, and the action was taken without any reference to the accumulation of the powder, which waited only for the spark to cause a severe explosion. No effort was made by the child's parents to draw out, but only to nip off and eradicate, all activities which seemed to endanger the artificial scheme of life. Of course this plan of blocking and discouraging advances in the open led to a complicated system of underground burrows, which attitude later caused considerable depression and a disinclination to form friendships. The unsatisfactory condition of affairs naturally gave rise to a feeling of isolation, induced by the lack of sympathetic surroundings and the unsatisfied desire to find some expression for hidden longings. The whole series of disquieting feelings was greatly exaggerated during the inception of puberty, and the oversensitiveness and feeling of insecurity were the cause of a serious tension which persisted for years, and later in life made it very difficult to see events in a perspective where the outlines and relations were not grotesquely distorted. The complete disregard for the discussion of primal needs and the general taboo placed upon any reference to the relations of the two sexes had, as might be expected, in many ways a very disorganizing effect. The repeated failure to adjust life and to relieve the strain of pent-up feelings resulted in various sentimental effusions and at the time gave rise to inexplicable emotional outbursts of considerable violence.



It is not necessary for our present purpose to describe in detail the strange medley of forces which were gathered under a smooth exterior. It is, perhaps, sufficient to say that the direction of discharge was influenced by a number of physiologic factors. As the inclination to associate with members of the same rather than the opposite sex was a dominating impulse, in this way the general direction given to the stream of activities was clearly established and eventually had a decided influence leading to celibacy. This is a very important fact seldom considered in relation to the determination of the intellectual and temperamental qualities. The vague but impelling sense of a physiologic defect was, to a considerable extent, responsible for the rather intense interest developed later of assisting other people to improve their lot. As soon as the revolt came, just after puberty—a revolt which followed the definite recognition of things not being quite as they should be—there developed a tendency to classify not only experiences but persons as well into groups. Ideals, defects, successes, failures, persons, esteemed or despised, were no longer treated in an individualistic manner, but were quickly grouped into classes. The reason for this action was not only the expression of an almost universal desire to generalize, but by so doing the unsuccessful personal efforts to adjust life were lost sight of. It was evidently a pleasanter occupation to think of the trials and failures of large classes in society than to be continually absorbed in contemplating one's own difficulties, which were suggested if the attention was directed toward problems even remotely concerning individuality. The extreme annoyance caused by having once been placed in a position requiring servile rejection of personal opinions and obsequious deference to conventionalities was symbolized by a complete agreement and sympathy with the views of persons who were members of a "class" which in the main suffered from the effects of indignities and humiliation similar to those received by the patient.

It was a simple matter to trace the effect of the pent-up

feelings and high tension of the early years in the process of formulating opinions upon social and ethical problems. The idea of individuality was eliminated and was replaced by a series of "class judgments," with the result that the road to salvation was assumed to lead straight through the possessions of those whose expressed views made the most direct and sustained appeal by reinforcing and compensating for a weakened sense of personality.

The intellectual, neurotic type affords many interesting examples of rationalizing in order to effect a semi-compensation. Some form of mystic philosophy is often adopted by psycho-neurotics in their unsuccessful effort to stabilize a weakened personality. In the continual struggle to secure adaptation to the environment when the concrete realities press too heavily, such a mind is concentrated on the distant view and the details in the foreground are overlooked. "The earth," to a person in this condition, "seems a purgatory for divine spirits who have been assailed by sinful thoughts. I feel that our world has become an immense negative and that everything noble, beautiful, divine, has turned itself into satire." The reaction is similar to that of the person who, weary of looking at a fight directly in front of him, gazes at the hills in the distance which are too distant even to suggest any signs of the conflict taking place in the neighborhood.

When the balance of the synthesis is disturbed, every effort is directed toward restoring the equilibrium. In some people frantic attempts are made to camouflage the realities that by circumstances are daily forced upon their attention. The extreme views often expressed by some persons possessing the artistic temperament represent the length to which the failing sense of adequacy drives neurotics in seeking explanations to justify their own secret longings. Often the complaint is made that the world is no longer capable of appreciating true art or music and that the special qualities of mind essential for the enjoyment of the works of great masters have died out, never to be revived. The temperamental inconstancy and the

rapid fluctuations in the emotional life are so distracting that attention is shifted from the contemplation of present exigencies to dreams about what the future may hold in store.

The psycho-neurotic delights in emphasizing his independence. He would like to enjoy popular success, but since that is generally impossible he tries to make up for its loss by referring to the banality and keen eye for business of those who do. Like the man who whistles to keep up his courage, he never misses an opportunity to refer to his own youth, vigor, and calm judgment. If this braggart happens to be an artist he describes his own pictures as genuine works of art in contrast to the great mass of mediocre productions. He revels in so-called new forms and new combinations of colors which he believes the average person cannot see or appreciate. The new art holds such undisputed pre-eminence in the minds of those who alone are supposed to be capable of judging it that critics are treated with calm indifference. The roots of these over-valued ideas extend far below the conscious level and are inaccessible to the corrective influence of reason. Temporarily removed from annoying rivalries and disturbing criticisms these independent artists find sufficient comfort in reflecting upon their own imaginary supremacy while continually reviewing "the membership of that small group containing all the vigorous thinkers but none of the weaklings or old men who keep to the conventional lines." They cannot realize at all that the appeal of anything reactionary stimulates them in much the same way that some trivial incident does a child who is predisposed to "tantrums."

Personality studies show very clearly that rational thought plays a very small part in forming the conceptions so dominant in the new art. These "new" artistic conceptions are the products of some of the oldest and most conventionalized reactions of the human brain, since they represent primitive emotions inadequately expressed, but sufficiently strong to throw the higher centres of rational control out

of the circuit. Practically this same complex of symptoms is found in all the radical reactionaries against present conditions. The present, irrespective of conditions, is what irritates beyond measure the psycho-neurotic who dreads being brought face to face with realities and is forever striving to invent some new method of giving at least an appearance of rationality to wishful thinking.

It is interesting to note how mental processes closely related may lead to the expression of ideas which, measured by superficial contrasts, seem to be as far apart as those of the ultra-conservative or the radical libertarian. Although the ideas expressed in both cases appear to be widely divergent, they are not due to the calling into action of widely different functions. The slave of tradition and the iconoclast, if judged merely by their own words, seem to be standing at the opposite poles, but when their mental processes are subjected to close analysis the antithesis is not often great.

In some instances the desire to get away from the cold facts of every-day living is so pressing as to tempt the person into dwelling in an imaginary world. While living under these conditions visions representing life as it is conceived to be in the middle ages or in a very remote past may assume an extraordinary degree of vividness. Weary and disappointed by present-day conflicts and harassed by unfulfilled ambitions, the world as it appears in such day-dreams contains only vague suggestions of struggle; and in the process of semi-rationalizations these conflicts are often represented as poetic conceptions and the symbols expressing them are practically bids for peace at any price, and particularly for peace without victory.

Many instances could be cited, particularly among the intellectual classes, where the irritating memory of a failure to adjust life successfully increases the emotional stress to such a degree that obsessions and overvalued ideas seem to have completely mastered reason. The mind, starting from a false premise, attempts to effect some kind of readjustment, but the elaboration necessary to accomplish this

often leads to falsification of the data presented by memory, followed by the arbitrary exclusion of all evidence not leading to the speedy realization of desire.

The immediate cause of the isolation of certain processes, with their inaccessibility to the corrective influence of reason, is not known. In pathologic states it has been suggested that separate foci form, and around each of these more or less independent systems are arranged. These systems may be of such magnitude and possessed of so high a degree of organization as to suggest the existence of a double personality. The different phases of multiple consciousness and the psychologic aspects of multiple personality have been studied with interesting results.\*

Sometimes while studying the outlines of a personality we are struck with its inconsistencies, which stand out prominently and seem to be as detached from the rest of the synthesis as are the galls or an abnormal growth on the leaf of a tree, or an abnormal growth on the surface of the body. A person who normally reacts unostentatiously to the environment appears to acquire suddenly inexplicable traits and strange enthusiasms. Unexpectedly there is turned toward us for our inspection a phase of character we did not know our friend possessed. It is as if the cat had been unexpectedly let out of the bag. The excessively pious person upon slight provocation may become exceedingly profane, or the evangelist scrupulously avoiding even the appearance of a desire to curse may show the existence of repressions in voluble and impassioned references to hell and damnation. Experiences of this character show how often persons become missionaries through repression mechanisms and not by voluntary choice.

Some pacifists, like the subjects of attacks of acute mental depression, would actually rather prefer death than to be compelled to face the recollections of the ignominious defeats in their own lives. The conscientious objector refusing to take an active part in settling a great crisis in history by

\* Sidis, Boris, and Goodhart, S. P., *Multiple Personality* (D. Appleton & Company, New York, 1905.).

the use of arms, is an expert in the art of self-deception, and as a rule shows a strange incompetency in dealing with the problems of ordinary life. He is generally anxious to appear detached and independent, and longs to give the impression of living in the world while not being of it, but fails to realize that this purpose can only be accomplished by encouraging a selfish disregard for the rights of other people. In the struggle to acquire an independent position he may go to the extreme and succeed in detaching himself from any sympathetic relations with his immediate family, while presuming to regard this separation as evidence of supreme devotion to an ideal. Quite incompatible with the complacency exhibited in public in discussing plans for the general improvement of mankind is the extreme irritability noticeable when a person in this state of mind is called upon in private to adjust some difficulty in his own life. Every idea of struggle is repellent, while, as there is no compensatory feeling of the joy of living, the sense of oppression may be very great. The spectre of unfaced responsibilities is continually threatening, and, as only struggle and defeat have been experienced, the idea of victory is excluded, so that extra precautions are taken to prevent the recurrence of disaster which would destroy every vestige of hope. The cry of "peace without victory" has a much deeper personal significance than doctrinaires are willing to admit. The pacifist's precipitous pursuit of universal "peace" often suggests the drowning man's spasmodic gasps for air. Pacifism is a public apology for withdrawing from the world of realities. Sometimes the impulse to get away from the sting of any memory of personal defeat is so impelling that the imagination is called in to assist in the effort to get rid of every trace of the debacle. The idea of performing a special mission, of assisting in the regeneration of society, may be quickly substituted for disheartening recollections of never having succeeded in the mastery of self. If the life of the professional pacifist is closely studied there is generally evidence to be found of the struggles made to break away from every annoying social restriction that in

any way reminds this copy-book idealist of the difficulty he has experienced in the unsuccessful effort to secure social adaptation.

It is well known that exaggerated emotional currents very often quickly narrow the mental vision. The angry man, the lover, the sentimentalist—all see only one side of their object and are incapable of appreciating opposing tendencies. A man who under ordinary circumstances thinks straight may, when he is excited, be quite incapable of carrying a thought through to its logical conclusion. It is, of course, possible for two opposing systems to be represented in a mind, and so long as they do not come into actual conflict a semblance of harmony may be maintained. If, however, the conflict begins, then any one of a thousand different lines of readjustment may be attempted. The greater the original intellectual capacity possessed by the person afflicted, the more numerous are the possible ways for attempting to secure a readjustment. Occasionally the external conditions are so very threatening that the person is made a prisoner within his own soul, with the result that if later the habits formed during the period of living within high walls are changed, vagaries, buffoonery, and carousals may follow—a kind of behavior for which there has been no prevision.

Belief and conduct should be reconciled and never divorced or separated by water-tight compartments. When the effort is made to keep works and faith separate, one of two things is sure to happen. There may be either an impairment of intellectual vigor, or there may be many marked anomalies of the emotional life. Illustrations are numerous of a person's inability to think straight and persistently, when unsuccessful attempts have been made to reconcile the facts of existence with some mystic faith. Unfortunately, there is still much in our American education which encourages the formation of this dual system, with its disastrous results. As already stated, one of the first effects of this dual system is apparent in a loss of intelligent interest in concrete problems and the substitution of "hopes

for the future," while the imaginary glamour of anticipated events leaves no time for the appraisal of the present realities of life.

This tendency drives a person into a defensive position which requires explanation. It is precisely this condition which has produced so much of the present-day sophistry, with the inclination to generalize and the substitution of vague claims of humanity for the demands made upon us as individuals to do our own part well. *Humanity* is treated *en masse*. Individual characteristics are seldom taken into account. One large group of persons—capitalists, laborers, socialists, or syndicalists—is said to represent all that is good or all that is bad, and virtue is to be found in a single class only. We feel an imperative demand to consider the needs of the masses because our own self-insufficiency prevents us from taking up the unsolved problems at our front door.

It is interesting to observe the inconsequent way in which many reformers, paying scant attention to the character of the mental mechanisms exhibited in advocating or defending their cause, practically adopt the same method of presenting their arguments to the public as was followed by those demanding the burning of Savonarola, insisting upon Galileo recanting, and calling for the execution of Servetus. There is indeed something almost ludicrous in the appeals for social reform couched in language suggesting the same overflow of emotion that marks the action of a devotee worshipping at some shrine or that demanded the quick destruction of all dissenters. In all such cases where the element of prejudice is strongly marked, there is a special mechanism by which a complex of ideas is shut off from other systems and acquires independence.

The intellectual or spiritual life, either of a people or of an individual member of a community, cannot be measured without first observing the direction and strength of the currents running far below the surface, and then taking note of the forces lying outside the field of consciousness—deep in the physiological levels. In daily life numerous examples



are to be found of persons fighting hard to subdue a feeling of inadequacy. Their ideas as expressed symbolize inner conflicts and often represent the results of mental strife in terms suggesting the sublimated metaphysics or the phraseology of the early mystics. The phenomena of religious life also not infrequently reveal the manner in which the entire person is emotionalized and the volitional life controlled by the sweep of sentiment and feeling—with the subsequent dissociation of the personality. When once the ideas have been "fixed" and definite trends given to a thought, the original emotional reactions may disappear so completely as to leave scarcely a trace behind them.

The same mechanisms directing men's feelings and shaping their opinions to-day have operated for centuries in controlling human behavior and regulating its expressions. In our clinics there is ample opportunity to study concrete examples of the same attitudinizing exaltation of the past for its own sake, and the subordination of fact to feeling, which were characteristic of many of those who were engaged in writing the biographies of the saints.\*

In the case of the Jewish race we have an excellent opportunity to study the effect of certain innate qualities and social customs in producing signs of dissociation recurring with such a degree of regularity that they are generally spoken of as racial characteristics. If Myerson† is correct, certain innate tendencies have been exaggerated by a social development in which the Jew was excluded from all those occupations in which the motor side of his nature could have found adequate expression. This neglect resulted in the race adopting forms of occupation which led, not only to undernourishment and physical underdevelopment, but to an overstimulation of the emotional and mental life. The associated exaggeration of introspective qualities increased the liability to nervousness and various forms of dissociation.

\* Gerould, G. H., *Saints' Legends* (Houghton, Mifflin Company).

† Myerson, A., "The 'Nervousness' of the Jew," *J. Ment. Hygiene*, vol. IV, no. 1, 1920.

Years ago, in discussing the nature of delusions, Sully\* showed how easy it is for a falsification to be dragged into a chain of reminiscences and to stand out sharply as quite unrelated to any occurrence that has really taken place. Recently Healy has reviewed the literature of pathologic lying and has added interesting studies of new cases. He is inclined to take the view that attributes these phenomena to a splitting up of the personality with unsuccessful efforts to reconcile the "ego" of the transformed individual with the original one which appears only at intervals.†

History furnishes many excellent illustrations of the "fixing" action of the emotions‡ in directing the current of desires and aversions, in making belief inflexible, in producing stupid obstinacy and intolerance, in turning men's minds away from the present, and in dissipating their energies while they are lost in rapt admiration of the past or dream of the future. Taylor,§ in his description of the mediæval mind, has traced the steps in the typical mediæval emotion which gave that special cast to the mind recognized as characteristic of the middle ages. The same traits as were dominant in those days and led men to feel "the need of grasping the universal thought symbols" are often met with to-day. Emotion still compels expression and "feeds itself upon its expression, thereby increasing its resistlessness." To-day, as formerly in the age of St. Francis or of Salimbeni, we find many examples where passionate energy is the directing force, controlling the intellectual faculties.

\* *The International Scientific Library*, 1883.

† Healy, William and Mary T., "Pathological Lying, Accusation and Swindling," *Criminal Science Monograph* no. 1 (Little, Brown & Company, Boston, 1915).

‡ Blight, S. M., *The Direction of Desire. Suggestions of the Application of Psychology to Every-day Life* (Oxford University Press, Oxford, 1910).

§ Taylor, Henry Osborn, *The Mediæval Mind* (The Macmillan Company, Ltd., London, 1914).

## CHAPTER XII

### METHODS OF STUDYING THE PERSONALITY

THE art of studying a personality requires breadth of view, skill in technique, and special experience in dealing with human beings. It always calls for a keen and precise analysis of temperament, character, and intellectuality, as well as of those relations to other personalities that are expressed in social and ethical adjustments. In analyzing a personality we have to consider the general emotional and mental make-up of a person at a certain stage of development.

It would not be possible, within a brief compass, to describe in detail the special methods used in the examination of a personality. The reader is referred to the various works on anthropology, as well as to those describing the methods employed in the clinical examination of patients and in the selection of special types of personality, as for example the aviation service, army, navy, or for the performance of special tasks in civil life. Draper's\* outline of a plan for recording the physical and physiological characteristics, and Hoch and Amsden's well-known "Guide to the Study of the Personality" contain useful information. For additional information the reader should consult the papers of Hrdlicka,† Davenport,‡ Jelliffe,§ Franz,|| Terman,¶ and Ball,\*\* describing methods used in anthropology, eugenics,

\* Draper, George, "Clinical Study," *Endocrinology*, 1919, III, p. 164.

† Hrdlicka, A., *Amer. J. Physiol. Anthropol.*, 1919, II, no. 3.

‡ Davenport, C. B., and Laughlin, H. H., "How to Make a Eugenic Family Study," *Eugenics Record Office Bulletin*, Cold Spring Harbor, 1915.

§ Jelliffe, S. E., *Technique of Psychoanalysis* (Nervous and Mental Disease Publishing Co., New York, 1918).

|| Franz, S. I., *Handbook of Mental Examination Methods* (The Macmillan Co., 1919).

¶ Terman, L. M., *The Measurement of Intelligence* (Houghton, Mifflin Co., 1916).

\*\* Ball, T. B., "The Correlation of Neurology, Psychiatry, Psychology and General Medicine as Scientific Aids to Industrial Efficiency," *Amer. J. Insanity*, April, 1919, p. 75.

and dynamic psychology. The special examinations are described in various papers in the current literature.

It should not be forgotten that the object of a personality study is to measure the general adaptation, not only in degrees of contentment, but in terms of outward achievement.\* In order to make this estimate correctly the capacity for dealing with men as well as with things and ideas should always be kept prominently before the mind of the person conducting the examination. Too much emphasis should not be given the intellectual achievements, but account must be taken of special abilities and disabilities, and the dynamic quality of the mind thoroughly studied.†

In following out the lines of examination and collecting data bearing both on the physical and mental qualities, it is not possible in many cases to see the relation that one set of facts has to the other. This defective correlation, however, due to our own ignorance, should not make us forget we are engaged in trying to solve a biological problem in which both groups of data have some definite relation, even if we are not able at present to establish the connection. Of course in a few striking types of personality the interrelation is apparent, as in the following cases cited by Draper:

*Type I:* In his personal history we should not expect to find he had ever suffered from an infectious disease unless it had been typhoid, malaria, or tuberculosis. Among the chief physical characteristics are delicate pink and white skin, a high hair-line on the forehead, and some tremor which is increased after drinking coffee. There is slight nervousness and a history of sleeping poorly. The metabolic changes in this person are very active and above the normal.

*Type II:* Marked by extremely dark complexion, with considerable pigmentation, normally disposed, and with excessive growth of hair and low-growing scalp-line. This

\* Wells, F. L., and Kelley, C. M., "Intelligence and Psychosis," *Am. J. Insanity*, July, 1920, p. 17.

† Bronner, Augusta F., "Individual Variations in Mental Equipment," *J. Ment. Hyg.*, July, 1920, IV, no. 3. *The Psychology of Special Abilities and Disabilities* (Little, Brown & Co., Boston, 1919).

individual has certain definite immunological reactions and shows a decided tendency to work for a few hours in succession and then give way to fatigue.

*Type III:* This individual contrasts strongly with the other two, as he has a large, flabby frame, prominent upper jaw with widely spaced teeth, and in his personal history there is evidence of his having been a large infant and always above the average size. He is apt to have had a certain more or less definite group of diseases and has an increasing tolerance for sugars.

These three types of personality, with distinct mental and physical characteristics, show the importance of studying personality from a broad biological standpoint. If the mental life of these individuals was studied apart from their physiological reactions and final characteristics, it would soon be evident that consciousness, as Woodworth\* has reminded us, is not a coherent system. As a matter of fact, we cannot attempt to find rational explanation for the specific characteristics in conscious processes in such different types unless these are referred to the temporary dispositions and subconscious adjustments which are so closely associated with all the biological processes. In trying to analyze the personality it is essential to adhere to the dynamic point of view and to resist the temptation to accept the fragmentary evidence furnished either by the behaviorist or the students of the arbitrarily isolated conscious processes as explanatory of the personality. In the study of personality we have to account in each instance for the persistent clear tendencies based on specific physiological characteristics which are responsible for the reactions appearing in behavior.

Every person has certain definite physical and mental characteristics. These are responsible for the personal appearance, as well as those attitudes and reactions recognized as characteristic. The significance of these attitudes and reactions could not be understood from any single cross-

\* Woodworth, R. S., *Dynamic Psychology* (Columbia University Press, 1918).

section of life. We have described the innumerable impressions, both inherited and environmental, giving shape to the specific attitudes which are collectively described as a person's character. The phases of character, including the instinctive, emotional, and intellectual responses, we summed up as the personality, which represents the total make-up or constitution of a person at any one period of life, whereas we study a person's individuality to get a clearer idea of the special traits that distinguish him from other people; therefore the personality is the value assigned in the general scale by which human beings are measured. All the various reactions expressed in the personality have to be taken into account, and their relative valuation correctly estimated. Sometimes there is a tendency to devote too much attention to the intrinsic to the neglect of extrinsic factors, or, as is the case at present, individuality is forgotten in the discussion of social adjustments.\* Individuality and personality for the moment are overlooked, as the public at present is chiefly interested in the collective aspects of life.

Not only is it necessary for the examiner to acquire the technique of examination, but in order to be successful he has to establish sympathetic relations with the subject of examination, to penetrate to the core of the personality and so discover the hidden forces which give it shape. The examiner should cultivate, like Sir Thomas Browne, "a constitution so general that it consorts and sympathiseth with all things." The successful examiner, however, is born, not made. One may acquire, by diligent practice and long experience, some considerable skill in exploring and exposing the basic influences which condition character, but there is a point in the analysis beyond which the examiner cannot go unless he himself possesses the peculiar adaptiveness and insight associated with a natural aptitude for making personality studies. This is an element which has to be taken into account, as the academic psychologist

\* Follett, M. P., *The New State* (Longmans, Green & Company, New York, 1918).

is too much inclined to assume that with the aid of the Binet tests and other more or less conventionalized schemes the foundations of temperament may be explored and the results charted with the same ease and accuracy shown by the navigator in plotting out longitude and latitude.

The data that throw any light upon the influences shaping a personality must be gathered from many fields, and represent the efforts of investigators attacking this biologic problem from a great many different angles. The facts relating to the physical as well as the mental life have to be carefully compared and their relation to the individual's character considered. This requires a great deal of experience, first in getting the facts, then in analyzing them and piecing them together so as to give a composite picture of the entire personality.\*

At the risk of repeating what has already been said, a reference will be made to two or three general principles which every examiner should keep constantly in mind in order that the perspective essential in correctly judging traits and qualities should not be lost sight of. Thus, while it is often necessary to analyze special functions and single traits, attention should not be focussed exclusively on these, as it is the behavior of the machine as a whole that is the chief object of investigation. The investigator trained in laboratory methods is very apt to lose a sense of perspective and fails to note the relation of the organ or organs which he is investigating to such general reactions as are expressed in thought, word, or conduct. The assumption should not be made that the analysis of the functions of different organs is necessarily a more scientific undertaking than is the careful inquiry into conduct with the view of determining the motives for action, together with the forces shaping a personality. A good many physicians have the idea that the problems of behavior either cannot be attacked from what they believe to be a scientific standpoint with scientific methods or are of relative unimportance in com-

\*Rosanoff, A. T., "A Theory of Personality Based Merely on Psychiatric Experience," *Am. J. Insanity*, 1921, LXXVII, no. 3, pp. 417-436.

parison with the conventionalized and standardized lines of investigation carried on in clinics and laboratories.

Nothing is more unfortunate than the notion now so prevalent that a mere acquaintance with the formal details in the technique of examination is sufficient guaranty that accurate information will be obtained. At present the disadvantage of placing too much confidence in methods is illustrated by the indiscriminate application of the so-called intelligence tests. These tests are often made by persons who have had no clinical experience in observing human beings, and they are therefore not competent either to select the cases in which satisfactory results can be obtained or to express a critical judgment upon the relative value of the different data. A good many psychologists who still accept the old distinctions between body and mind believe that in the study of character a psychological analysis of the personality without reference to physical qualities and the general physiological responses is of great value. This attitude has been responsible for an exaggerated faith in the efficiency of special methods of examination, and with the aid of charts or prepared schemes the superficial qualities of temperament and character have been noted without paying any particular attention to the more fundamental biological processes taking place at lower levels. It is surprising how far academic psychologists without any accurate knowledge of the machinery concerned in the emotional adjustments will attempt to go in interpreting the data gathered from intelligence tests; and in doing this they are apt to assign a value to the conscious processes out of all proportion to the real part consciousness plays in the rôle of adjustment. As a matter of fact, the character of the conscious processes may be noted, but the relation of these adjustments to those taking place in other levels often does not appear, nor can it be inferred from any of the information available. When this happens scrupulous care should be exercised not to establish or even suggest a series of false relations which seem to be temporarily serviceable in adding a sense of completeness to the personality



study. The penchant to stretch a fact so as to obliterate any trace of incompleteness in a history is a constant source of error. An error, once introduced into the records as the result of the personal equation of the examiner, as a rule is difficult to detect and easily becomes the basis for a great many false generalizations. One reason why so much emphasis is placed upon the importance of recording observations in a simple, straightforward manner without necessarily calling attention to the various implications is that the failure to observe this precaution has seriously interfered with progress in the study of human behavior.

A point of vital importance to be observed in preparing to take any record is to decide as to the purpose and object of the procedure. The investigation of a personality may be carried on in such a general way that the records would soon become too voluminous. The study of a personality, in order to be complete, would cover most of the field of human history. For this reason the scope of the examination should be accurately determined, and the data collected should have a more or less definite bearing upon the main object of the research. In order to make clear this principle, let us take a few illustrations. It would be impracticable in the ordinary clinical examination to make a detailed study of the hereditary predispositions, as this undertaking would cover such a vast field that little real progress could be made in collecting innumerable details and then summarizing the results in a form to be of service to physicians. For the same reason it would not be advisable when collecting information upon the inherited trends to expect that the history of a nervous breakdown should be given as fully as when the object of the examination is merely to make a diagnosis and outline treatment. Up to a certain point details are essential, but undoubtedly the rate of progress would be more rapid if the examiner tried to preserve a sense of perspective, and was not afraid, on the one hand, of indicating the practical bearing that the information gathered has upon the definite problems of the investigation, or, on the other, whenever needed was not equally frank in

indicating the absence of any such relation. The examiner should be so thoroughly trained in the technique essential for making detailed studies that his common sense will tell him when a reasonable opportunity exists for probing for facts useful in throwing any light upon a personality.

Of course, it is often necessary to make a great many entries recording observations that seem to have no immediate practical value, but this does not relieve the examiner completely from the responsibility of being intelligent and considerate of the task imposed upon other people of reading pages in which a vast amount of material is presented without any attempt having been made to exercise a critical spirit in the selection and arrangement of the data. Sometimes the statement is made that a great deal of the material collected, which seems to be quite irrelevant, eventually may be brought together and important deductions drawn from the results of observations recorded in a very discursive manner. This supposition has many disadvantages. In the first place, time and energy are wasted in digging out a few facts from a large mass of unimportant and often trivial details. Then too, as the methods of examination are improved, short cuts will undoubtedly be found for arriving at the same results in a much more direct manner. Voluminous and undigested histories of cases are chiefly of value in demonstrating the dogged persistence, and uncritical and unimaginative spirit, in which the examiner has approached his task. It is desirable to cultivate the art of following definite lines of examination having some goal in view, and subjecting the evidence gathered to critical analysis before incorporating the results as an integral part of a permanent record. Diffuseness and prolixity are sometimes mistaken for care in searching for details and the patience necessary in accurately recording observations.

One of the first groups of factors to be considered in beginning the study of a personality is the so-called racial qualities. Here at once we meet with many practical difficulties, and unless great caution is exercised the tendency

to become both inaccurate and discursive may be very misleading. For practical purposes a few brief remarks upon general racial characteristics may serve as an introduction to the record. But this part of the record should be brief and not suggest too strongly the existence of specific racial characteristics. In discussing the question of race we are actually dealing with "an abstract conception," according to Topinard, "a notion of continuity in discontinuity, of unity in diversity." The difficulty of picking out the elements or traits, physical, psycho-physical, morphological, and physiological which are distinctly racial is an exceedingly difficult if not impossible task.\* For the present, at least, we have to bear in mind the fact that most of the recorded anthropometric data have no direct bearing either upon the so-called racial qualities of a people or the individuals composing the arbitrarily selected race. We do, however, in connection with the investigation of so-called racial traits, often get an excellent idea of the environment in which a person has lived and of the family customs which often have such an influence upon children that the habits formed are suggestive of inherited racial characteristics. It is only fair to say, however, that there are a number of anthropologists who believe it is impossible to correlate a good many physical and mental qualities with definite racial characteristics.† Lapouge, for example, believed that the dolichocephalic type was generally the "exploiter, adventurer, and wielder of ideas and dominates in arts, commerce, science, and letters." This particular opinion has been elaborated by Madison Grant,‡ who has presented the claims of the Nordic type. These questions need to be much more fully discussed, and for the present the tendency to champion special racial claims should be avoided and a field of scientific inquiry should not be allowed to become a stage upon which are presented the arguments favorable

\* Stevenson, B. L., *Socio-Anthropometry*, Human Personality Series (Richard G. Badger, Boston, 1916).

† Lapouge, G., *L'Aryen, son Rôle Social*, 1899, Paris.

‡ Grant, Madison, *The Passing of the Great Race* (Charles Scribner's Sons, New York, 1919).

to some political allegiance. As the examiner should be an investigator and not a propagandist, it is far safer to assume, in attempting to ferret out the facts relating to racial trends, that, although certain peoples have developed special mental and physical characteristics, the effect of racial segregations upon mankind is not by any means as distinct and as directly favorable to the transmission of definable ancestral qualities as it is in the case of the lower animals.\* For this reason it is well to avoid dogmatic general statements in regard to race, unless these are supplemented by information giving an idea of the character of the environment in which the person lived. To-day such expressions as "pure stock" or "Nordic type" can have little value unless the information gathered together in the history presents satisfactory evidence bearing upon the points under discussion. The real sequence between cause and effect stands out clearly in a personality study, not when the effort is made to try to bring out some hypothetical relation supposed to be characteristic of mind and race, but by directing attention to reactions between the environment and the individual organism.

In investigating the influence of inherited qualities it is also necessary to restrict the field to the data bearing upon the particular problem under consideration. Naturally this part of the examination includes a summary of both physical and mental qualities. In the case of the personality, however, although reference should be made to the first group of factors, in the case of the latter the correlations can only be very remote, as we have to consider the feeling, ideas, hopes, and the various forms of conscious adaptations involved in the multiplicity of the social contents. As it is not specific traits, but only proclivities and aptitudes that are inherited, it is evident that these depend upon subtle and complex arrangements which at present escape definition. There is a prevailing tendency to speak of the inheritance of definite traits which finds little justification in fact.

\* Briffault, Robert, *The Making of Humanity* (George Allen and Unwin, Lt'd, London, 1919).

This is true both in regard to pathological qualities and in the case of the marks of genius. Knowlson\* is quite right in affirming that we cannot hope "to find the origin of genius in the doctrine of inheritance." After reviewing the evidence now available it is useless to declare that much light can be cast upon the occurrence of unusual and extraordinary gifts by the information possessed in regard to heredity. In making an examination we have to distinguish very carefully between the influence of the home environment in supplying an atmosphere favorable for the development of certain qualities and the instinctive and emotional drive due to inherited qualities. Few persons who have not had a great deal of experience in making personality studies can appreciate the difficulty of arriving at any definite conclusion in regard to the relative value of the environmental and inherited influences. Very few histories contain information which is of much value in drawing any definite conclusion in regard to just this particular point. What is so often described as evidence of the inheritance of mathematical or musical talent is seen to be based on only insufficient evidence. Suppose that a son or daughter shows a strong inclination to follow in the footsteps of either parent and in many ways gives evidences of developing the interest and capacity characteristic of either father or mother. We cannot say just how far one is justified in attributing this result to inherited trends or to the effect of sentiment and filial affection acting at a period when the young person is particularly sensitive to suggestion. There are instances when the hereditary factor in the development of genius seems to be strongly marked, but, on the other hand, there are fully as many cases where unusual traits and ability develop in the children of apparently mediocre and undistinguished parentage. In these latter cases it would be an interesting investigation to try to discover whether the real qualities of the parents were hidden and repressed and had not had an opportunity for expression.

\* Knowlson, T. S., *Originality; a Popular Study of the Creative Mind*, p. 65 (J. B. Lippincott Company, 1918).

For the present we have to be satisfied with collecting data relating to the problem of heredity, but extreme caution should be exercised in drawing any conclusions from relatively few facts.

The general method of examination is practically the same in all cases, and the technique is not difficult to acquire for any person who has had the preliminary training in the study of human behavior. The method of conducting the examination has been outlined by Davenport and Laughlin.\* As already intimated, the results of the investigation should be simply and concisely stated, without attempting to deduce any conclusions not justified by the information available, and often refraining from drawing arbitrary distinctions between traits supposed to be inheritable or non-inheritable. The "Pedigree Chart" reproduced from Davenport and Laughlin's pamphlet illustrates a number of the more important points to be observed in filling out the history. Great care, however, should be observed in making these diagrammatic representations of a family history, to avoid the tendency of speaking of the inheritance of specific traits. We can easily become accustomed to making this mistake if there is occasion to plot out a great many charts. Unconsciously a symbol used in a history to indicate, for example, the existence of "artistic ability" or "mathematical genius" may lead to the belief that these aptitudes may be categorically described, with the result that the inheritance of well-defined qualities and not merely proclivities is received as an accepted fact. We should also be cautious in announcing that such qualities as "Wanderlust" illustrated by the gypsies and persons of nomadic temperament, or the "sea-lust" (thalassophilia) in naval officers, represent a definite and distinct racial trait.† The probability is that this so-called definite trait can be resolved into several different factors, all of which are not inherited.

\* Davenport, Charles B., and Laughlin, Harry H., *opus cit.*

† Davenport, Charles B., and Scudder, Mary T., *Naval Officers, Their Heredity and Development* (Carnegie Institution of Washington, 1919).

PEDIGREE CHART

Brief instructions for constructing a Pedigree Chart and for designating the family distribution of specific traits preparatory to making a descriptive analysis of the innate traits of each individual.

SMALL SAMPLE PEDIGREE SHOWING USE OF SYMBOLS, ETC.

Name of person making this study.....Address.....Date.....

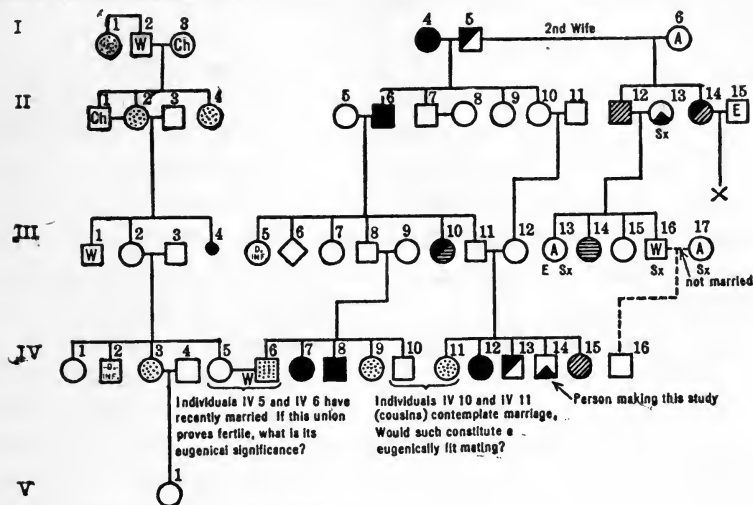

Explanation of the above pedigree chart

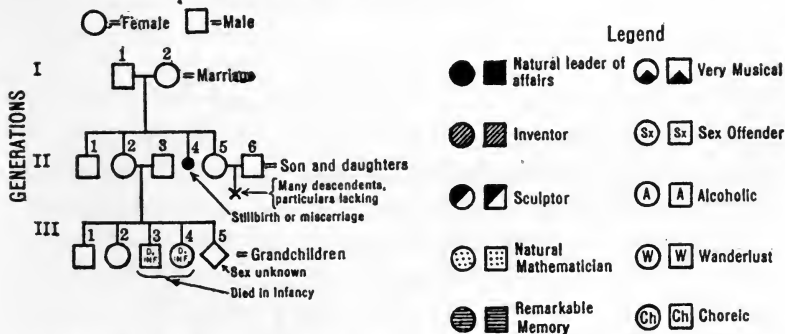

An explanation similar to this one should accompany each chart. The letters or symbols representing the traits characteristic of the family studied are arbitrarily chosen by the person making the chart. Only a few symbols—and those for defects—have been standardized, e. g., I=Insane, F=Feeble-minded, Ch=Chorea, E=Epileptic, A=Alcoholic, etc., etc.

NOTE.—Such a chart is only the beginning of a eugenical study, but it is very useful for showing graphically the "family tree" and for indicating in a general way the most striking traits of its various members. In order to determine the hereditary potentialities of an individual, each of the several members of his or her family network must be described—both as to good qualities and defects—with care, accuracy, and frankness. For this purpose the "Individual Analysis Card" is supplied.—Eugenics Record Office, Cold Spring Harbor, Long Island, New York.

The record of family traits may be kept upon blanks similar to those furnished by the Eugenics Record Office, Cold Spring Harbor, N. Y. The charts for recording the observations conducted with a view to determining the inheritance of musical talent is useful in indicating the general field of examination in such special cases.

In conducting the examinations there are two groups of inseparable functions which have to be considered. On the one side are the components of what we ordinarily call character—the collective individual peculiarities, including the moral force, general stamina, and persistence in overcoming opposition—and on the other hand are the mental functions, collectively designated as intelligence.

The former is the executive group of functions, complementary or supplementary to those represented by the thinking, selecting, integrating, and deciding judicial functions usually described as mentality.\* The recognition of this tentative grouping seems to make for simplicity and facilitates description, particularly when dealing with pathologic cases. As Fernald has said, the innate intelligence defects are irremediable, whereas defects of character may be improved, or at least compensated for, by intelligent direction. Upon this basis it is easier both to establish some kind of measurement for the intelligence defect and to make notes of the variations of character. Each case should be studied upon its own merits.† Davenport‡ clearly indicates our proper attitude toward these great questions when he writes: "For a long time yet our watchword must be investigation." Until quite recently we have made the mistake, when conducting an investigation of inheritance traits in human beings, of postponing analysis until all the complex machinery is in action or budding proclivities have developed into traits; and little attention has been devoted

\* Fernald, Guy G., "Character as an Integral Mentality Function," *Mental Hygiene*, July, 1918, vol. II, no. 3.

† Guyer, M. F., *Being Well-born*. Childhood and Youth Series (Bobbs-Merrill Company, Indianapolis, 1916).

‡ Davenport, C. B., *Heredity in Relation to Eugenics* (Henry Holt & Company, New York, 1911).



to tracing the different steps in the various basic integrations formed during infancy or early childhood.

Records made by careful observation of babies during the first year or two of life would furnish valuable information upon the elaboration taking place in the primitive instincts and earliest emotional reactions, and would also make it easier to get some idea of the nature of the proclivities which are inherited.

The history of the following case will illustrate how hopeless it is at present in the great majority of instances to draw any definite deductions as to the relative part played by heredity and environment in causing general emotional instability. Probably if a few reliable observations had been made by the physician who took care of this person during the first years of his life, sufficient data might have been obtained to justify a reasonable assumption as to the nature of the proclivities of which his character was the expression:

Patient complains of worrying unnecessarily over business affairs and admits "at times is pretty blue." Volunteers statement that he cannot assign any cause for mental depression, as he has been "reasonably successful in business." Partner in large book business. Male, age 35, native U. S. Born in —, parents both native Americans. F. d. "Bright's disease," age 70. M. l. age 65, always "nervous." Two brothers, both younger; one strong and husky, other weak and "nervous." One S. youngest member of the family—not very strong—high strung—learns lessons quickly at school, but seems to be easily fatigued and can't stand excitement.

Has been told that he was a small, rather poorly nourished baby. Apparently had good many "upsets" during infancy, although nothing of serious nature. Information comes chiefly from the family physician. No record of any organic lesion. During early childhood had both measles and scarlet fever. No marked sequelæ except increased nervousness following latter disease. Remembers that for year or two slept poorly, dreaded being left alone in dark.

Went to school at seven years and made good record "with his books." Always stood well in his classes, "pleased both parents and teachers," although he was very irritable at times and had attacks of "tantrums." Graduated from Primary School with "honors" and began work at High School. Had attacks of "nerves," and physician's record shows that at times "the movement of hands and feet

suggested chorea." Continued to stand well in classes, although nervousness was at times very annoying, particularly the attacks of egotism alternating with greatest self-depreciation in facing any emergency. Was recognized as one of "the best scholars in the school." Thinks he became more and more dependent for his happiness upon the opinions expressed by his teachers as to the merits of his book-work. Does not seem to appreciate the sacrifice he made in losing the desire for independent thought or action. Became depressed as soon as he failed to win approval either at home or school. When closely questioned in regard to the details of his home-life, said he had a deep affection for his mother and was accustomed to go to her for advice and sympathy, but stood more or less in awe of his father, who, although "a very just man," had a quick temper, was often silent and unapproachable and so absorbed in his own affairs he often gave the impression of not taking very much interest in the ordinary events in the daily life of the family. The young man picked up his information about sexual matters from a variety of sources, but had never dared to mention the subject to his parents. Had masturbated for a short time, but had never made a regular practice of it. Was always interested in girls and remembers being very much attracted to one or two girls while he was in the early "teens." During the High School and University period the traits of temperament and character to which reference has been made became more and more exaggerated without any sudden transformations being noted. The egotism became more pronounced, and he grew to be resentful of any infringement of what he believed to be his personal rights. This failing led him quite easily into sympathetic relations with all persons who were trying to champion "the rights of other people" and who believed themselves to be wronged or oppressed. Admits he was opinionated and fond of arguing, while much given to criticising the acts of other people. At the same time he became apparently less conscious of his own defects, and was quick to blame existing social conditions and the fancied hostile attitude of many people for his inability to adjust his own life satisfactorily. Socialism and all reforms which in his own mind seemed to have as their chief object the levelling down of all outstanding personalities and the reduction to a common level, even though it be one of mediocrity, of men of unusual ability were doctrines which had a strong attraction, although he was unwilling to admit the source of his "democratic instincts" or to face squarely the problem of the origin of motives which were responsible primarily for his conduct and the opinions shaping his course in life.

It is not necessary to go into this case more in detail nor to comment upon the importance of "the records" obtained

at various intervals in throwing light upon the forces controlling the entire personality. The hypersensitiveness for incident stimuli, the general lack of repose, the hypertrophied ego acting as a compensatory form of reaction to offset fundamental defects like lack of confidence, and the eager search for some support to strengthen a weakened personality are phenomena capable only of being interpreted properly by a knowledge of the original endowment at birth and the subsequent modifications produced by environment.

In the more primitive types of reaction it might be possible to discover some of the inherited tendencies which shape the entire mental life of adult years. Consider how great would be the interest, for instance, of information bearing upon the emotional reactions of the infant Darwin. Even in these reactions we might find some clue to explain the great pertinacity of purpose and clear judgment, which were the distinguishing qualities of his prime. Watson\* has confirmed our impression, formed years ago, to the effect that the study of the primitive infantile reactions would open up an instructive field of investigation and bring to light valuable data for the understanding of the actual structure of a personality. A brief study of the reactions of a baby to environmental stimuli would suffice to convince any intelligent observer that the innate responses of the adult "are not by any means the results of the mechanization of acts performed in a deliberate and voluntary manner with conscious intent."† The whole problem of psychological inheritance has been looked at too exclusively with reference to the conscious processes. We must go much deeper and find out something about the glandular activities and the rôle of the autonomic nervous system in shaping the patterns of the emotional responses that prepare the way for the higher forms of mental activity. By pursuing this line of investigation we shall in time very probably gain reliable information as to what constitutes "the original

\* Watson, J. B., "Reactions in Psychological Experimentation," *American Journal of Psychol.*, April, 1917.

† Chase, H. W., "On the Inheritance of Acquired Modifications of Behavior," *American Journal of Psychology*, April, 1917.

nature of man" and also what distinguishes the differences between the inherited and the acquired mechanisms. Restriction of our interest to an interpretation of the mental qualities in adult life will not further our knowledge in this respect.

The study of the problem of inheritance in connection with nervous and mental diseases deserves mention. Nature's analyses in disease are so much more satisfactory than the inexpert attempts of human beings that much valuable information is gained by following her lead.

There are two distinct sets of opinions about the inheritance of the defects leading to the imperfect adjustment described as mental and nervous diseases. On the one hand, there is a theory, formulated by Esquirol and Morel, that hereditary degeneracy is responsible for practically all kinds of nervous and mental disorder, and that the earliest symptoms appearing in the first generation are accentuated in successive generations until the fifth one is reached, when Nature cleans the slate by wiping out the degenerate stock. Morel made special use of the word "degenerate" and emphasized the aggravated conditions which he thought followed the inbreeding of defective strains. The line began with people who possessed neurotic constitutions; the neuroses increased in the second generation, becoming progressively more marked until the fifth generation, when the line ended as the result of sterility. The term "degenerate" is now about all that remains of Morel's hypothesis, since his claims have not been vindicated. Cases now included under the head of degeneracy usually show some abnormal state of the mental machinery, like increased or defective sensitivity, or some rare form of ideation.\* But as these stigmata are only symptoms they form no basis for classification. Another group of mental degenerations with marked physical signs of degeneracy seems to indicate that ancestral experiences are factors of much significance.

\* Haberman, J. B., "The Degenerate: In Delinquency and Criminologic Heredity," *Arch. Diag.*, April, 1917, N. Y.

The use of the terms "moral insanity" and the "born criminal" (the first used by Pritchard in 1835 and the second by Lombroso in 1882) have led to erroneous conceptions about degeneracy. Pritchard had the idea that there were people with no apparent intellectual defects who were handicapped by a very great limitation in the development of the ethical and moral qualities. This idea was altogether different from that advanced in explanation of the criminal by Lombroso, who supposed the feeble inhibition of the chronic transgressor of the law was partly due to organic inferiority and partly to the too great prominence of atavistic qualities, and therefore he believed this group to represent more precisely an anthropologic than a degenerate group. Nordau's theory was offered to account for criminal tendencies on the ground of parasitic qualities developing as the result of an indefinite form of degeneracy. As a matter of fact, any of these cases might be grouped under one or the other of two heads: (1) those in which there is a definite impairment of the mentality, and (2) those in which the intellectual functions are not markedly disturbed, but whose mechanisms shaping the emotional reactions seem to be so peculiarly susceptible to incident stimuli that the control of voluntary activity is most difficult. Because of the historic interest associated with a series of terms which have been used in court-room and clinic, we have made reference to them and have also taken the opportunity to show the inadvisability of employing most of this data gathered to fit in with the formal requirements of definitions. There undoubtedly would be an enormous gain if we were justified in assuming the reliability of the large amount of information bearing upon the cases now classed as degenerate; but patience must be exercised until this knowledge can actually be demonstrated as true. For this the value of carefully prepared records with details essential for the formation of correct judgments cannot be overestimated.

Esquirol and Morel's doctrine of polymorphism has had many adherents, although vigorously opposed by other investigators, especially in Germany, where the idea has been

disseminated that certain forms of mental diseases may be grouped together, these peculiar types excluding others from appearing. Berze has assumed a condition that he calls a secondary "blastodysgenesis," in which some injury is thought to have affected the germ-plasm, following disturbances in the general physical condition.\* In this country Davenport and Rosanoff† have worked along the lines suggested by Mendel, and Myerson‡ has recently reviewed their conclusions. The latter believes that the neuropathic constitution differs from the normal one in the lack of a normal determiner, and also takes exception to the view that the Mendelian hypotheses are always applicable in explaining the transmission of human traits, since the theory has only been proved correct in the instance of eye color. For this and other reasons the plea is made to avoid running too far ahead of the facts. Myerson's monograph should be read by every one interested in this field of research. Although his views are briefly expressed, there is no dogmatism in his conclusions. Studies made by Rudin on the transmission and reproduction of dementia præcox§ are particularly interesting, both on account of the conclusions drawn and for the light they throw on the general problem of the inheritance of pathological traits. He is convinced that the study of the laws of heredity, as it is generally undertaken along conventional paths, is bound to fail. In addition to collecting data upon the families showing obvious cumulative hereditary effects, he believes that attention must be paid to the families in which such traits are not markedly dominant. Until this is done there is no adequate means of making successful comparisons. He advises also a very careful study of the products of cross-breeding in stock that shows no pronounced pathological symptoms. Rudin concludes that, among the children hav-

\* Berze, *Jahresb. u. d. g. Neurol. in Psychiat.*, 1904, p. 967.

† Davenport, C. B., and Rosanoff, J., *Nerv. and Ment. Dis.*, 1911, p. 64; also in *Am. J. Insan.*, 1913, p. 1.

‡ "Psychiatric Family Studies," *Am. J. Insan.*, 1913, LXXIII, no. 3.

§ Rudin, E., "Transmission and Reproduction of Dementia Præcox," *Monograph. a. d. Gesamtgeb. d. Neurol. u. Psychiat.*, Berlin, 1916, H. 12.

ing one parent free from dementia præcox and the other affected, there is no doubt that this disease is more frequent (6.12½%) than among the children whose parents are both free from this disorder. There must be reason, however, to believe that dementia præcox is represented by a recessive hereditary tendency. The results of these examinations deserve very careful consideration, and the reader is referred to the monograph for details. As has been often repeated, it is almost hopeless at present to base any very definite statements in regard to the inheritance of normal qualities and specific personality traits, upon the information now available.

Once light has been thrown upon the problems connected with the more marked disorders of temperament and character, then the way is opened to study the inheritance of normal traits. A more complete understanding of the nature of such mechanisms would entitle us to draw inferences about eccentricities of temperament and character associated with the cases recognized as distinctly normal. These preliminary steps having been taken, we are in a position from which to make a successful assault upon the many problems of heredity that now seem unapproachable. At present our main need is a thorough study of a comparatively small amount of material rather than the accumulation of large masses of imperfectly analyzed statistics. There must be active and intelligent co-operation of a large group of investigators if we are to have complete histories. When it becomes possible to say with certainty that, given one form of mental disease in the ancestral line, we may know just what form of disorder to expect in the descendant, the way will be cleared for an explanation of the nature of mechanisms concerned in the transmission, not only of mental defects due to definite lesions but also of a great variety of abnormal functional conditions. We have no idea at present what factors are actually concerned in the transmission of these abnormal emotional and mental processes.

Often there is a tendency shown by a certain group of investigators to read their own pessimism into the interpretation

of the data collected in reference to the subject of the inheritance of pathologic characteristics. This is not justified any more than is an extreme optimism. It is well to keep in mind the fact that in presenting the results of an examination the question of racial degeneration should not be considered without reviewing the factors which suggest regeneration.\*

Having completed the family history, the person's own history involving the consideration of both physical and mental traits is undertaken. This covers a large field, and here again the object for which the investigation is made should count as an important factor in shaping and limiting the scope of the examination.

After the physical examination has been completed the psychological analysis of the personality is taken up. In general, as has been already described, this analysis involves the consideration of two definite groups of function. On the one side, as Fernald† has reported, we have to consider intelligence, including thinking, inventing, combining, planning, and deciding functions, as contrasted with the energizing, emotivating, sentimental, instinctive, and executing functions. The former group is collectively described as intelligence or mentality and the latter as character. Of course, we must not make the mistake of assuming that these two groups stand in sharp contrast to each other. As a matter of fact, they are closely related and interdependent. The attitude of mind which assumes a superiority of the intellectual functions is apt to forget the foundations upon which these rest. To the failure to observe this precaution may be traced the unreliability of the results obtained from the application of purely "mental tests." It is foolish at any time to disregard the nature of the biological organization of the personality and to restrict the field of study, merely to analysis of the mental reactions without taking into account the various deviations in character. In the main, however, the recognition of these two large groups of functions—intellectuality and character—serves a useful and practical purpose in classifying the re-

\* Apert, *L'hérédité morbide* (Flammarion, Paris, 1919).

† *Opus cit.*



sults of the study of personalities. But we should, moreover, resist the temptation to regard these functions as standing in too sharp contrast. It is unfortunate to consider the reactions grouped together as stationary, as this requires the misleading static conceptions which assume definite states of mind. In dealing with intelligence, as well as with character, we are concerned with active processes of adaptation, so that it is not correct to assume, as is sometimes done, that in cases of mental deficiency the intellectual processes are stationary and do not change as compared with the plastic and adaptive character of the other reactions.

There are a few practical suggestions that are useful in studying a personality. (1) The circumstances of the first meeting between the person and the examiner should be described, stating the essential points referring to the circumstances leading up to the meeting, the general character of the reactions, and notes upon what happens as soon as an opportunity is given for relaxation after the initial tension is relieved. These first interviews often are very important in giving an insight into temperament and character. Some people meet the examiner half-way, while others at once stiffen up, are thrown on the defensive, and become suspicious. Very often the defensive attitude is aggressive and masquerades under an offensive egotism or a pompous and overbearing manner. When in the presence of this type of personality it is necessary for the examiner to control his own feelings and wait patiently for an opportunity to find an opening in the armor, and as a rule this is not as difficult an undertaking as is commonly supposed. Generally a passive attitude is more successful in exposing the real defects than a counter-attack would be. If the person examined comes to rest, there are still many important points to be noted. The pose, the facial expression, the extent of the relaxation, including both physical and mental reactions, should be carefully observed. The interest shown in what is going on may be exhibited in countless ways that escape notice unless attention is directed toward

them. The observer by using tact and maintaining his own self-possession may generally give an opportunity to the person under observation to come to rest. Having secured the desired information in regard to the ability and capacity to relax into a more or less passive state of mind and body, the changes are noted when stimuli are supplied. These first observations generally give some indication of the balance of the personality. It does not take long to determine whether a disturbed balance is the result of intelligence or character defects, and we soon get an intimation of what the nature of the causes are that produce such symptoms as disquietude, suspiciousness, aggressiveness, etc.\*

(2) Reactions to the immediate situation. A flood of valuable information can be immediately obtained by an intelligent, well-trained examiner who is not handicapped by dependence upon some system of "tests" in judging the manner in which the immediate situation is presented, sized up, and reacted to. As a rule the experienced observer is quick to detect the significance of a gesture, the slight change in facial expression, the alteration in pose, that sometimes speak more than volumes in giving a clue to the real personality. The signs of embarrassment, the flushing of the face, dilation of the pupils, quivering of the lips, slips in pronunciation, sudden fluctuations in attention and interest, the slight difficulties, under the influence of excitement, in co-ordinating movements, the hop-skip-and-jump form of conversation, the flight of ideas or extreme circumstantiality are all interesting superficial indications of the depth and strength of the currents sweeping far below the surface of a personality.† Keen and practised observers are quick to note and appreciate the significance of the apparently trivial events in the first interview with a person who is under observation. It is also true that the attitude of the observer, although not analyzed, is

\*Brown, Sanger II, "Medical and Social Aspects of Childhood Delinquency," *Am. J. Insanity*, 1921, LXXVII, no. 3, pp. 365-385.

†Jelliffe, Smith Ely, *The Technique of Psycho-Analysis* (Nervous and Mental Disease Publishing Company, N. Y. and Washington, 1918).

under close scrutiny and he may easily prejudice his case by a tactless and unsympathetic approach.

It is well to recognize a few of the difficulties to be met in beginning the study of a personality. In the case of the apparently indifferent person a decision should be reached as to whether the indifference is assumed or real, whether it is the result of emotional or intellectual defects, or is a definite defense reaction hiding the real personality. Instead of indifference we often meet pronounced aversions and various degrees of disinclination to assist in the analysis. Tact, intelligence, and great patience are often necessary in order to insure any progress being made in the examination. In marked contrast to these cases are those in which the apparent readiness to supply information may also be a ruse for concealing important phases of the personality by diverting attention away from personal qualities which the subject realizes will not bear close scrutiny. Sooner or later, however, and generally as the result of indirection, the real personality begins to emerge.

## CHAPTER XIII

### THE INTELLIGENT DIRECTION OF ACTIVITIES

#### (EDUCATION)

WHEN John Locke wrote to his friend Edward Clarke those letters known as "Thoughts on Education," he admitted at the start that he considered that education principally concerned itself with the forming of children's minds, "giving them that seasoning early, which shall influence their lives later." He moreover advanced the novel position that he should put the subject of learning last, because, "I tell you I think it the least part. This may seem strange in the mouth of a bookish man, and this making usually the chief if not only bustle about children; this being almost that alone, which is thought on, when People talk about Education." Wise words which, if they had been more nearly followed in the education of our youth, might have lessened our perplexities to-day in regard to the problem of the intelligent direction of activities.

In the discussion of educational problems an understanding of their variety and biological significance is particularly needed. At present the educational campaign to direct our energies to better advantage is carried on by various field services, which, working without any knowledge of the general purpose and scope of other operations, are marked by much confusion of intention and enormous waste of energy. The responsibility for this disadvantage must lie in the patch-work character of most of our schemes for educational reform, social improvement, and betterment of living conditions. Real progress toward such betterments demands a biological view-point, and intensive co-operation in the numerous departments of research.

Within the limits of a brief account of the educational process we can present only a short summary of what seem

to us the chief landmarks, and for this we can do no better than take as our first step a clearer conception of the scope and significance of educational problems. At the start the habit should be formed of always associating the word *life* with words suggesting the commonest phases of human behavior—home, school, college, social and political life, the life of the courts, prisons, reformatories, and of individual persons and groups, such as the life of a community, nation, and race.

The main object of an education is not to develop mental states but to provide rational assistance in directing vital processes; and this is seldom done, so that the different phases of a collective activity are not usually discussed in terms implying vital processes. No attention is paid to the biologic setting of the educational problem, minor details absorbing the attention with no consideration of the more general methods needed in the prosecution of the work. Political leaders, lawyers, educators, physicians, and every one engaged in the study of special phases of human behavior, and all persons who take an intelligent interest in directing human endeavor—whether parent, social worker, or teacher—have a common object, did they but know it, and should be sharers in a common store of knowledge. Success in assisting human beings, either individually or collectively, to adjust their lives demands familiarity with the mechanisms involved in successful adjustment; and the basic mechanisms are the same, although the individual variations are countless.

The aim of education, which should be biological and not academic, may be described briefly as an effort to direct human activities intelligently. Intelligence in such an effort presupposes preparation for it, and those who claim to establish ideals for conduct, to prescribe rules for living, or to suggest remedies for disorders in adjustment without any definite capacity or training for the purpose, must of necessity fail. Mistakes in our present educational methods are only too evident if we count the number of unfortunate people filling the police courts, almshouses, reformatories,

hospitals for the insane, and sanatoria for the cure of nervous disorders; maladjustments representing only different phases of *one great unsolved problem*, instead of innumerable problems, differing radically and specifically from each other, as so many social reformers, lawyers, and clergymen would have us believe.

In discussing these different phases of ill-adjusted lives, there has been hitherto little idea of attributing these failures to the educational system, nor has their significance been grasped, with the result that the various degrees of success or misfortune in adaptation, as expressed in the varied personalities, have been described in a terminology and spirit suggestive of a narrow academic interest.

Often the jurist engaged in interpreting human laws, the historian striving to make plain the lessons of the past, the teacher intent upon shaping character, the parent desirous of aiding his children to acquire good mental habits, do not realize that this work has a common purpose in view—to discover the principles by which human behavior may be regulated successfully. If we can but establish some kind of rapprochement among persons engaged in the study of all these phases of human activity, we shall have prepared a basis from which successful attacks may be made along many lines; and particularly is this true in regard to those lines described as educational.

The increase in the incidence of insanity, the rise of the ratio of the emotionally unstable, the multiplication of the number of those with unsocial instincts, should admonish us of the deficiency of our present system in schools and colleges—a system tempting people to accept the benefits of an “education” which will not profit them, but rather lead to an environment where success is impossible and disappointment and failure the penalty. Adequate measures to meet the situation confronting us are dependent upon the speedy recognition of the necessity for developing a system of education by which rational assistance shall be given to human beings seeking to satisfy the demands imposed by living under present conditions.

To the specialist in nervous disorders it is obvious that present educational methods drive many persons by what are euphemistically called educational opportunities into an environment so unsuited to their natural capacities as to necessitate a subsequent readjustment. This squeeze process comes often at the time when the contacts with the world lying outside home and school are being established; and at this critical period much of the available energy is disastrously dissipated. The student undergoing the strain of readjustment of sentiments, feelings, and phases of the volitional life, tending in themselves toward much disorganization, finds his or her completed academic training frequently without that elementary knowledge essential for rational living. Many a college graduate is right in questioning the value of a diploma.

Any movement to meet this just demand for a true education implies possession of a comprehensive knowledge of human activities. To direct the stream of energy to the best advantage we must know all that we can of its source; and this involves, as already intimated, consideration of the inheritance of traits. A teacher, using the word inheritance in its broadest sense, should be expected to make some effort to form an idea of the natural inherited aptitudes and dispositions of the pupil.

If we recognize that the mind is largely a social product, we shall avoid many of the unnecessary difficulties introduced into the discussion of the inheritance of mental characteristics. Because of the fact that the mental make-up is, to a considerable extent, the result of environmental stimuli, it is to be considered as a "social contribution."

Mental potentiality is conditioned by heredity, but development is encouraged or inhibited very largely by what happens after birth. There is also some reason to believe that changes in nurture may serve as stimuli affecting the growth of the embryo through the parental germ cells. Inheritance has been compared to the seed corn and nurture to the soil, sunshine, wind, and rain. Nurture alone is incapable of creating anything, but without its influence

the buds on the stalk would not swell and blossom. It may be foolish to try to make a silk purse out of a sow's ear, but, as Thomson\* says, a single talent may be traded for two or even more. It is unwise to dogmatize in any way, since our ignorance of many fundamental facts is as yet great; and, as Davenport writes:† "Whether we consider the growth of the body, the development of the functions, or the education of the mental faculties, we do not yet possess even the rudiments of the knowledge of the most successful development."

The mechanisms concerned in the expression of inclinations or tendencies appear to stand forth more prominently in the highest and lowest levels of the scale than in the intermediate ranges. In other words, we find that the relation of family traits to individual achievement is generally more easily traced in the cases of genius and delinquency than in a person of average ability. The educator may often obtain information as to the talents or natural potentiality of his student by eliciting information about special defects or talents of members of the family. Although the effort should most certainly be made to throw as much light as possible on the antecedents of the person examined, much care should be taken not to make any very definite deductions from such data, because so little is as yet known of the underlying mechanisms.‡

In some cases the attention has been focussed too exclusively upon the physical traits, and Davenport§ is right in asserting that in the investigation of hereditary tendencies all too much is made of the physical examination, all too little of temperament and intelligence. Whether the love of the sea, as exemplified in the lives of distinguished naval officers, proves to be a definite instinct (thalassophilia), as he believes it to be, it would be foolish to disregard the

\* Thomson, J. A., *Eugenic Rev.*, 1916, VIII, p. 50.

† Davenport, E., *Country Life* (Ginn & Co., 1916).

‡ Guyer, M. F., *Being Well-born: An Introduction to Eugenics*. Childhood and Youth Series (edited by M. V. O'Shea; Bobbs-Merrill Co., Indianapolis).

§ Davenport, C. B., *Naval Officers, Their Heredity and Development* (The Carnegie Institution of Washington, 1919).



deeply rooted character of the tendencies which, undoubtedly, contribute to the success of a Nelson or a Farragut.

Even if the information relating to the inheritance of mental traits is very limited an interest in this subject would often be useful, in cultivating in teachers some appreciation and reverence for the deeply rooted character of many personal qualities; and also in giving them some idea of the home environment. In a preface to *A Study of the Dock Family*, by Mrs. Finlayson,\* Davenport has referred to the complexity of the problem of the analysis of complicated processes such as emotional characteristics. We, however, are inclined to take exception to the tendency to treat so complex a mechanism as a quick temper like a functional unit and an evidence of a Mendelian dominant. We believe it preferable to call attention to the recurrence through different generations of certain dispositions, and to try to analyze the various processes forming the complex.

The real foundations of an education are laid in infancy; and parents and other persons having charge of infants should be trained to take an intelligent interest in directing the integration of processes upon which the personality is built up. It is quite obvious that no intuitive knowledge is a sufficient equipment to guide any one in directing the development of a personality, nor can any satisfactory result be expected from one whose only qualification is sentimental interest in a great biological question.

From infancy onward there should be a really intelligent watchfulness practised in order to direct the activities of the child. Even at birth, when a human being is practically "a soulless spinal thing," there are a number of important reactions taking place in connection with mechanisms established at the lower levels, and these reactions should be carefully studied because they furnish some clue to the possibility existing at this early stage of guiding them with intelligence. The interrelations of the mechanisms

\* Finlayson, Mrs. A. W., "The Dock Family. A Study in Hereditary Lack of Emotional Control," *Eugen. Rec. Office Bull.*, no. 15, 1915.

concerned should emphasize the need of caution in attempting to modify the natural impulses of the infant. The changes in bodily weight should be noted, since by regular comparison of the baby's weight with the recognized standards an excellent idea of its progress may be obtained. The symmetrical development of the body is usually accompanied by the evolution of forces tending toward a well-rounded personality, and some notion of what the organization of temperament and character will be may be gathered from the early characteristics. Many of the difficulties experienced during school and university years, when undesirable mental processes are hampering and annoying, have their origin in trends which, if not inherited, have been established during the period of early infancy and childhood. The nervous person may be born with an inherited neurotic tendency, but this may be greatly augmented by the treatment received from well-meaning but unintelligent and injudicious care during the first years of life.

Nervous symptoms should be recognized as signs of imperfect adaptation, since, if uncorrected they may lead to cumulative processes in which abnormal trends will be superimposed on others in the effort to compensate. Thus excessive impressionability and the tendency to be easily frightened are both danger-signals which should warn us to remove their causes if possible. Other signs of imperfect adaptation in infants are abnormal sensitivity to bright lights or shrill sounds. About these reactions, as the range of adaptation extends, others are grouped that later on form detached complexes incapable of being brought into harmony with the rest of the personality.

Again, before the organization of the higher mental processes has advanced very far, some estimate may be made of the store of reserve energy, as well as the capacity for concentration, by noting the degree of persistency associated with any effort to accomplish some definite purpose. One infant easily tires of trying to grasp some bright object dangled before its eyes, while another persists in the attempt,

both babies clearly presenting some of their primary temperamental qualities by their actions.

In certain of the early activities we may also estimate somewhat, the part anxiety is to play in frustrating an organization favorable to the expenditure of energy with least waste. In the nervous baby the element of "fluster" is soon introduced with its tendency to encourage disorganization. By taking account of the activities under the control of the involuntary nervous system we may readily form a fair idea of what the child's emotional development will be. The bodily characteristics of dry skin, rosy complexion, large pupils, and fairly rapid heart of one baby are sure to develop, unless some accident intervenes, quite a different type of child from the infant with a moist skin, small pupils, sunken eyes, and slow pulse. Comparison of these two types will forecast some of the reactions which later determine the set of character.\*

Another signal of importance that the "educator" should look for is the first indication of excessive fluctuations in the dawning emotional life. Two antithetic periods may develop—one characterized by a propensity for and facility in action, and the other by a corresponding retardation of movement and a diminution of the usual emotional reactivity, during which period the reactions remain stationary.

The "educator" will also do well to watch carefully for any suggestion of what later may become alternating hyper- and hypo-kinetic periods (excitement and depression) in excess of the normal swings of the pendulum, since such symptoms, if uncorrected, may in after life lead to a particularly annoying chain of symptoms. In combating these unfavorable symptoms, the process of re-education should consist in making such changes in the infant's environment as will reduce the inclination to overstimulate its activities. Regular habits in feeding and sleeping should be encouraged, the high-strung, overzealous mother warned of their necessity, and the opportunity afforded nature to

\* Timme, W., "Autonomic or Vegetative Nervous System," *J. Ner. and Ment. Dis.*, 1914, XVI, no. 12.

restore the lost equilibrium. General neglect and indifference to the cultivation of good, regular habits in the infant are responsible for much of the misery accompanying the nervous breakdowns of adult life, and prevent the acquisition of many of the mechanisms essential for persistent and well-ordered thinking. Because of this fact the fussy, neurotic mother and father, so common in American life, are really a serious menace to the development of healthy and strong personalities.

There is a type of parent often found in families whose hereditary traditions and instincts for generations have been directed toward the performance of manual labor. A sudden change in their fortune leads to the acquisition of wealth, and the opportunity it affords the child for acquiring a scholastic type of education that produces conditions of environment decidedly unfavorable for adjustment. Again, the mother who, as the result of some defect or temporary obstacle, has not succeeded in adjusting her own life, cannot be expected to assist her baby to acquire those essentials of an education which form the basis for the process of which the school training is a mere incident.

At the end of the child's first year, when the movements have been more co-ordinated and a series of reactions has begun to crystallize about the primitive instincts, we have an excellent opportunity to determine to what extent nature and nurture are active in giving a definite stamp to the character of the responses. If at this time the reactions, which judged by their organization have scarcely risen above the reflex level, are not allowed to become disorganizing influences that preclude the infant from acquiring temperamental stability, much has been accomplished, not only to insure the foundations of a well-balanced personality, but to assist in establishing later the poise accompanying the mental habits specifically designated as "cultural."

If teachers, who to-day are very generally occupied in directing the process of habit-formation during somewhat brief periods of the lives of students, could be helped to observe the human machine during its most plastic period,

they would recognize the futility of trying to put in order a machine after it has been abused; they would also realize more fully the necessity of acquiring information about the formation of habits at a time when the fundamental mechanisms are in process of being laid down. Any expert in golf or tennis knows the need of making sure that motor-complexes concerned in driving the ball are first formed at an early age, so that the simpler motions shall become automatic. It is, therefore, strange that recognized authorities upon education are slow to appreciate the point that to encourage desirable trends and to effect a rational compensation for undesirable trends, particularly in their inception, is the only reliable method for insuring the acquisition of good mental habits.

The educational records begun with the observations made during the first year of life should be supplemented by a survey of the conditions at the end of that year. The record should contain some indication of the general growth, with notes about obvious defects. There should follow a description of the sensitivity to impinging stimuli, the co-ordination of movements and the chief characteristics of the more pronounced habits. This record, taken in conjunction with the increased adaptability occurring at later periods, should be useful in supplying information for the direction of the child during the kindergarten period, and, if sufficiently detailed, should be of aid in the prevention of many foolish experiments made upon little children that now receive the sanction of educators.

The effect of external stimuli in modifying or inhibiting reactions such as crying, swallowing, and the co-ordination of movements during this year should be noted, some infants being especially susceptible to visual and quite insensitive to tactile stimuli; others are altogether the reverse. It would be difficult to overestimate the importance of the close analysis of these early movements, their accuracy, the extent to which groups of muscles are thrown into synchronous activity, their uniformity in rate, and their regularity of rhythm. These very complex mechanisms in adult life

are often called into operation by the highly organized centres for voluntary control; so that in the baby we have exceptionally good opportunities to pick out the different steps occurring in the process of transition between purely automatic reactions and the incidence of those in which the elements of voluntary control are unmistakably present.

During the earlier years of life it is essential that the growing child should be protected from severe emotional shocks. Very often many forms of the dissociation occurring in adult life can be traced to unfortunate occurrences taking place during the period of infancy or early childhood. In the majority of instances the conscious memory of these events has entirely disappeared and their place is taken by strange impulses, or the reflex and automatic adjustments associated with intense emotional storms. Sometimes the occurrence of unfortunate events, although having no direct representation in the conscious life, finds expression in peculiar forms of symbolism occurring in dreams, curious aversions, and primitive types of behavior.

Educators should realize the very intimate relation between the mechanisms concerned in the co-ordination of movement and the phenomena of consciousness. If these primitive responses in the infant could be more thoroughly investigated, we should obtain many facts to aid in settling the question to what extent the motor processes form a part of consciousness. We might also ascertain whether we have thought of these higher processes in terms of too restricted a meaning.\* Close observation of active movements ought to throw much light upon what is really occurring in connection with the extension of co-ordination mechanisms, and the noting of customary postures and the distinguishing reaction stamped with individualistic characteristics should give additional and valuable information.

Among the processes which should be carefully supervised are those beginning very early in the child's life, and expressed in the phenomena of imitation. Some forms of

\* McComas, H. C., "Extravagances in the Motor Theories of Consciousness," *Psychol. Rev.*, 1916, XXIII, no. 5.

imitation, as Kirkpatrick\* has pointed out, are associated with the groups of movements marked by great complexity of organization, increased co-ordination, and decided dependence upon external factors such as those concerned with the act of perception. Another form, showing more elaboration than does the reflex group, is that in which the spontaneous imitation dominated by the perceptual element appears, a characteristic of the latter part of the first year. Efforts are at this time made to copy what is seen, babies differing much in their ability in this respect. Some seem to be unimpressionable and others hypersensitive to environmental changes, and between these extremes are all degrees of sensitiveness.

Following Kirkpatrick's description, we recognize the existence of dramatic or constructive imitation, which is distinguished from the spontaneous forms by the appearance of greater independence in representing what is seen or felt. Here we again gain an inkling of the future personality in its dramatic or individualistic propensities. On a still higher plane are the voluntary imitations in which the suggestion of purpose and the end to be accomplished make their appearance. Development of memory is, of course, important in all these syntheses. Finally the voluntary is expanded into the idealistic imitation in which certain standards for behavior are recognized. These many different levels are closely connected with each other, the normal baby's reactions passing without any break through them all.

The main distinction between the spontaneous and dramatic forms is the extreme literalness of the imitation in the first as compared with the second stage. The element of make-believe is characteristic of the dramatic imitations, and first becomes pronounced about the end of the second or beginning of the third year. Almost at the same time we see evidence of voluntary efforts to copy.

The imitation-capacity of the child at later stages, in which there is the general extension of the forms of adjust-

\* *Fundamentals of Child Study* (The Macmillan Co., 1915).

ment already noted, presents many interesting phases and may be gauged by the results of the following experiment. A few simple movements are made by the examiner and the child is told to repeat them. We notice to what extent the child looks at the hand or arm of the examiner while it is being moved, and observe if the attention wanders. In a very short time an excellent idea may be formed of the power of imitation, of the control of movement, of spontaneity of action, of control of action through sight and hearing, of the spreading or diminishing area of action, and of the extent to which action is influenced by past impressions. It is also interesting to note whether during examination there is a loss of co-ordinated action as the result of fatigue.

About the beginning of the third year the general trend of development has become quite marked, and constitutional defects, if any, stand out clearly enough to be easily recognized. The dawn of self-consciousness has commenced to form a registering dial for many of the compensatory processes which nature establishes in order to make possible, along a more extensive scale, adjustments in living.

The character of the motor reactions deserves particular attention. A very common defect in these processes throws much light upon the genesis of one of our national failings, namely, the inability to "sit at, or stand long on one job." Very few American children at this, or a later age, are able to stand well or easily. When they try to do so evidences of fatigue or overstimulation are seen. Many children of three years of age cannot stand quietly or easily for more than a few seconds. The restlessness and tendency to fidget, the inclination to stand first on one and then on the other foot, are familiar. There is perhaps no better test to find out the natural reserve power of a child, and to judge whether the energy is being directed in a way leading to the acquisition of a sound mind in a sound body, than to make this observation. Carefully note the ease with which a child takes and maintains an attitude.

After observing the child at rest and in motion, a useful trial of the reserve capacity may be made by requesting the



boy or girl to stand quietly and to hold the hands with fingers stretched widely apart flat on a table. A tendency to chorea will be revealed by the incoördinated sudden contraction of the muscles in the back of the hands and fingers. The readiness with which the request is complied with after a demonstration of what is desired, is a good indication of the ability to understand simple instructions and of the wish to follow them. In many instances the beginnings of opposing trends and cross-purposes are shown in the disinclination to respond to such requests. In the extremely neurotic, spoiled child, the behavior may even suggest "demoniacal possession." It is necessary that a child should respond easily and promptly to simple commands.

Any intelligent observer may gain valuable impressions of temperamental dispositions by studying the general facial expressions of a child and its attitude toward its occupation while engaged in doing something that has been demanded of it. In noting the motor reactions, we should remember the extraordinary prodigality nature shows in building up her selective processes. Countless movements are made, many of them appearing to be purposeless, which are gradually narrowed down until the desired effect with the least expenditure of energy is obtained. A little practice in observation enables us usually to tell when the assembling parts of a reaction are occurring in an orderly and consecutive manner. The certainty shown in the prompt execution of orders issued by the central nervous system is a pretty clear indication of that which is to be expected in the unfolding of the personality. Moreover, the feeling of assurance accompanying such simple reactions as those concerned in the movements of the limbs and in changes of the facial expression is a fair indication of the degree of tension that the organism is capable of maintaining. The confidence shown in lifting objects, in handling toys, in the use of a spoon or fork at table, in the efforts made to grasp things just out of reach so that the muscles must stretch to accomplish this, is a significant sign of the efficiency of the nervous system as a mechanism of adap-

tion in those levels that should be well protected and established upon solid foundations before the upper stories of the building of personality can rest securely.

If the motor processes are incomplete and the habit is formed of choking off one motor reaction before sufficient time has been given for its full play, a series of mechanisms is called into action that are pernicious in their effect upon character-building. Many bad mental habits in the adult are traceable to the chopped-off processes which in after life are responsible for waste of energy and time in a futile attempt to complete a series of movements, or to carry a train of thought to either its logical or biological conclusion.

The well-balanced personality predicates, in addition to the inheritance of good mental qualities, the possession of habits showing the person to have had the fortunate opportunity of developing natural resources and dispositions without having these warped out of shape by the aggressive interference of anxious parents and of abnormally solicitous pedagogues. A child who has once formed the habit of completing each series of actions has a feeling of confidence which is extended until it embraces many functions ranging all the way from a simple automatic impulse to the highly complex intellectual reactions; it is therefore imperative that a rightly conceived task should be completed and not allowed to be left in an unfinished condition. The disastrous effects following failure to recognize clearly this principle are brought out in many children.

Groos and other investigators long ago demonstrated the importance of the play instinct in children, but, although considerable valuable information has already been gathered in regard to this phenomenon, there is special need of further investigation of the play instinct as it appears in the period of late infancy and of earliest childhood. We need to know more about the occasions when the first suggestion of this becomes manifest, and must have an acquaintance with the factors contributing to, or interfering with, its progressive development.

Children show marked differences in regard to the play instinct, but we need to distinguish carefully whether poor development of the instinct is the result of transient causes or depends on those of a chronic or permanent nature. The lowering of spontaneity in efforts at play is an indication too often of imperfect adjustment; the lack of surplus energy to be expended for play shows an appreciation of the important fact that "*être c'est lutter, vivre c'est vaincre.*" \*

An educator who is accustomed to analyze the play of young children will find himself the more ready to guide them in their lessons, since such knowledge is the signpost indicating the direction toward which their activities should be induced to tend. Again, such a person will be able to estimate both the energy available, and the fatigue liable to be expected, together with the frequency with which fatigue symptoms occur and their persistence when developed. No one can give adequate instruction in the classroom who is not equipped with knowledge of the value of the various play reactions; intelligent appraisal of the adjusting capacity of each student must be demanded of the teacher.

Play, rationally directed, unquestionably tends toward the more complete and harmonious organization of the activities. For this reason it should be thoroughly studied with the purpose of ascertaining its values and limitations. None of the theories of play proposed as yet—including such noted ones as the catharsis or recapitulation theories—is altogether satisfactory; and its investigation has an important bearing upon our educational problems.

Many adults, particularly neurotic parents, have a pernicious habit of interfering with the normal play of children and are continually breaking in with suggestions, not giving a child an opportunity to follow its own bent and inclinations. The amusement-supplying neurosis is a very disturbing factor in the development of a good many children. Not only does the continual interference and the suggestion

\* *The Play of Man* (Appleton, 1901). Patrick, G. T. W., *The Psychology of Relaxation* (Houghton, Mifflin Co., 1916).

of new interests tend to make the child very nervous, but it deprives the young person of initiative in action and prevents the growth of a distinct feeling of satisfaction in having accomplished a purpose. The idea of purpose in the play of children is comparable to the sensation adults have in realizing they are engaged in a pleasant occupation which demands the exercise of both ingenuity and persistence. Many excellent qualities are developed if children are allowed to amuse themselves and are not constantly switched from one object of casual interest to another. It is a great mistake to give young children complicated toys to play with, and as far as possible they should be encouraged to amuse themselves in their own ways: provided, of course, these plays are not injurious.

The basic set of habit-mechanisms which are essential to real success and happiness is formed before the child goes to school, and it is in just this period, when the forces shaping character are still plastic, that in the American home so little attempt is made to co-ordinate and utilize them to the best advantage. The neurotic American mother or father is very much inclined to champion the rights of a great many people and to be equally regardless of the rights of his or her own children to live in an atmosphere which tends to encourage the development of the traits of temperament associated with stability of character.

At present many Americans are hypnotized by the advertised advantages of a scholastic form of education, and success among pupils is estimated largely by measuring the amount of information acquired from books. This is one reason why so many people assume that education begins in the school and forget the much greater importance of the home surroundings.

Our study should furthermore include the study of the very elaborate synthesis which we call curiosity. This is the chief incentive through which a constantly growing contact with the environment is maintained, and one most easily and frequently repressed or perverted by scholastic education. The mistake has often been made of trying to

isolate the so-called instinct of curiosity from other components of the complex, namely, attention and interest; and these factors are really inseparable.

Another form of instinctive activity deserving attention is marked by the desire to enter into competition. Greater information in regard to the nature of the primitive mechanisms of these reactions would enable us to understand many important aspects of the adult personality. We need to distinguish carefully between the normal impulse to enter into competition exhibited during health and the more aggressive response called forth as a form of compensatory reaction to cover up a defect. Such activities indicate the closeness of touch, as well as general success, of the individual in extending the number of contacts with his environment.

The ease with which a relatively good contact with the environment is formed and maintained, even at the reflex and automatic levels, leaves upon the mind of an observer, a very important impress of the nature of the empirical self as it gradually takes shape in consciousness. Such an impress, as we have seen in studying the personality, emerges from an extraordinary complex group of cœnæsthetic sensations, primary emotional reactions, and conations. The rapidity with which the individual child learns to distinguish the self from the environment and the ease with which any critical situation is faced, depend much upon the perfection of co-ordination and completeness of the motor processes. Much may often be done to insure the acquisition of a just and stable idea of self by giving nature a chance to work out the plan. Too many demands made upon the social instincts of the growing child quickly bring on trouble; and an abnormal dependence upon the favorable opinion of other people may be developed much earlier than the majority of people would believe possible. We notice, for instance, that in families where the parents are continually meddling with their children's amusements or inclinations, never permitting them to indulge in the kinds of play liked by young children, there results a state of emotional unrest that is quickly reflected in the behavior.

There are numerous opportunities in daily life, long before puberty, to detect the special influences which tend to the development of the normal well-balanced personality, or which show the defective mechanisms that, if not corrected, lead rapidly to involved mental states and make a new start in the right direction increasingly difficult. A change in the environment may reduce the strain imposed by these conditions, permitting a complete readjustment, but unfortunately this is not always the rule.

An experienced observer may quickly detect some of the causes for self-depreciation, a condition very closely related to the pronounced tendency of later years to mental depression. There may be at first only periodic attacks of shyness or a disinclination to mix with other children. In other cases conditions may be noted which, if persistent, may lead to an exaggerated egotism—a disposition reflecting the struggle to protect a hypersensitive nervous system from attack. Very often the causes of these maladjustments lie deep in the subconscious.

We are convinced from study of cases brought under observation that in the majority of people at the beginning of the disorder, there must be a common origin for the exaggerated self-regarding and self-abasing sentiments. Unsatisfactory readjustment to cover up a sense of defeat in meeting actual conditions is possibly the point of departure for both; and, although it is now impossible to say when the child first begins to be conscious of failure, there is no long interval after birth before the elements of these mental complexes begin to make their appearance.

Children vary both in ability to appraise and as to age when they estimate the relations they bear to other persons and use their judgment of these relations as the basis for determining their own behavior. All deviations from what our common sense tells us to be the normal limits for the standards of measuring the empirical self should be fully investigated in the child and unfavorable influences removed.

The earlier emotional attitudes—sympathetic, indifferent, or antagonistic toward the environment, as well as the child's

disposition toward members of the immediate family or relatives—may persist into adult life, causing definite trends of temperament and character to be established, and hence demanding careful study. The various episodes occurring during attacks of nervousness, or precipitated by overstimulation, may indicate the difficulties experienced in passing from one level of adaptation to another. Accurate study of symptoms may show definite constitutional inferiority and make clear the necessity of watching the ways in which compensatory reactions may be formed. Such an investigation explains many complex phases of the adult personality; it is often astonishing to what extent the trends of very early childhood are carried over into maturity. We have been so long accustomed to thinking of definite states of existence that we now find it difficult to apprehend the interlocking character of every level of development. We are inclined to think that unsatisfied longings, especially those lying outside the field of immediate consciousness, are mere incidents of purely local value in no wise responsible for the direction given to the stream of energy. We forget that, just as the course of a great river may be influenced by diverting from their beds the tiny brooks adding to the volume of the currents, so it is possible by throwing the energy of a human being into new channels, to induce profound changes in the formation of character.

Campbell\* has called our attention to the interest to be found in tracing many of the common symptoms of neurotic children back to the point where it is possible to get some inkling of their real biologic significance. If this can be done, we may be able to forecast their probably directive influence upon the events of later life.

When the time arrives for the child to begin school work the parent and teacher should have a definite idea of the problems involved in the proposed attempt to "educate": what functions should be "drawn out" and what suppressed,

\* Campbell, C. Macfie, "The Neurotic Child," *Amer. J. Dis. Child.*, 1916, XXI, pp. 425-444. "Education and Mental Hygiene," *J. Ment. Hygiene*, 1919, III, no. 3.

to what extent the natural trends may be directed or curtailed without disastrous results later.\*

Success in education we have already remarked should be measured by the direction given to the emotional currents, the growth of volitional activity, and the awakening of a few abiding interests. The disorganization of the financial world would be complete if as little attention were given to the formulation of financial problems as is shown by educators with no definite idea of the questions of really vital importance presented by the lives of boys and girls just entering school.

In making the examination of a child, a careful note of the characteristic postures and habits is most desirable, because these give an important clue both to physical condition and the nature of the mental processes. Such symptoms of defective adaptation as occur in tics, habit-spasms, or choreaic movements, demand modifications of the ordinary curriculum, if the subsequent discipline is to be beneficial and not decidedly harmful.

The tone and pitch of the voice very often give an excellent indication of the general emotional life of the child, with allowance, of course, for defects due to such local causes as adenoids, enlarged tonsils, or other forms of obstruction in the nasal and respiratory tracts. There is perhaps no better evidence of the successful adaptation of a person than is to be found in the general character of the speech—the quality of the vocal intonation and the signs of intelligent and natural inhibition indicated by the development of pleasing and the elimination of rasping tones.

Few people realize the exceedingly complicated mechanism involved in the wish to produce a single vocal sound. The lips, tongue, and jaw, which produce the distinct kinesthetic sensations, are in very close touch with the marvellously delicate laryngeal mechanism, while each set of organs is directly controlled by associated centres in the brain. If all these parts respond delicately and promptly

\* Barker, Lewellys F., "How to Avoid Spoiling the Child," *Mental Hygiene*, 1919, III, no. 2.



to appropriate stimuli so that a child produces a desired tone, he has already taken a long step on the educational highway—and yet a step seldom correctly estimated.

The quality of the vocal intonation, too, is very suggestive as to the probable temperament to be found. We are all familiar with the squeaky tones of the neurotic child, and are quick to recognize the deeper, mellower voice of the well-balanced, more phlegmatic type as an evidence of successful adjustment. Differences of considerable diagnostic value, such as stuttering and lisping, may be detected often as early as the beginning of the school period, and are signs not to be neglected.\*

Before admission to school, a detailed description of the motor reactions showing what the child is capable of doing and how much mastery it has over delicate movements, is most desirable. There is no scale of measurements as yet established to facilitate comparisons between the relative capacities of children at this age. A motor scale of development would certainly be advantageous in helping to solve many of the problems of education. Wallin,† in *The Mental Health of the School Child*, has pointed out the fact that “a sixteen-year-old child chronologically may have a twelve-year-old intellect and a fourteen-year-old musculature,” or the conditions may be reversed, necessitating considerable modification in the educational process to meet the special requirements. It is far more important to ascertain the future scholar’s capacity for doing things, and doing them easily and well, than to try to measure the stored-up information.

Attention should be directed to the preparation of the motor functions in order to lay true and firm foundations for the subsequent mental development. An effort should be made to correct the twitching, incoördinated activity of muscles so often noted in children, to make possible the establishment of a basis upon which to organize higher

\* Mott, F. W., *The Brain and Voice in Speech and Song* (Harper Bros., N. Y. and London, 1910).

† Wallin, J. E. W., *The Mental Health of the School Child* (Yale Univ. Press, New Haven).

levels, or to adapt these mechanisms so as to insure the carrying out of sustained efforts of any kind.

In this connection it is also well to test out the resistance of the child to fatigue. Many of the mental processes crystallizing during the early school years are in part fatigue symptoms, which either persist or later occasion unsuccessful attempts in readjustment that induce the formation of secondary mechanisms of an undesirable type. Even in young children we recognize some of the same signs of mental fatigue seen in adults, viz., the loss of interest and too great circumspection in dealing with difficult situations so that a sense of perspective is lost. Let us rid ourselves of the idea that fatigue symptoms exist in but one form or are usually easily recognized. They are in reality protean in character, and often crop up when least expected. We have mentioned the subject of the general effect of the cutting short of unfinished processes with the demoralizing influence upon the whole mental life; in states of fatigue this same undesirable thing happens, and curtailed processes lead to a building up of an artificial system of reactions marked by very great deficiencies.

One of the preliminary steps, before deciding upon the kind of education suitable for any child, should be to determine the degree of physical efficiency, and the resistance to both physical and mental fatigue. Important information bearing upon these points can be obtained by some of the tests modified for use in the examination of children, that have been applied so successfully in testing the endurance capacity of the aviator. In the first place, an excellent indication of the amount of energy available for periods of increased stress and strain is obtained, as Schneider\* has shown, by comparing the pulse-rate and arterial blood pressure, when the subject is resting, with the changes following standardized exercises. This information is supplemented by observations made upon the condition of certain reflexes, including the pupillary reactions to light and accommoda-

\* Schneider, E. C., "A Cardio-Vascular Rating as a Measure of Physical Fatigue and Efficiency," *Jour. A. M. A.*, LXXIV, pp. 1507-1510.

tion, the psycho-motor tension as shown in the ability to relax voluntarily, and, of unusual importance, the phenomena described as dermatographia, which has been carefully studied by Major William MacLake.

If a few brief notes on the personality accompanied these records, an excellent basis would be presented for judging the reserve energy of pupils and their capacity for enduring strain. Should the examiner describe only the manner in which the pupil reacted to the examination, important light would often be thrown upon the personality.

It occurred to the writer, while examining aviators, that if the phenomena described as dermatographia were carefully studied and the findings correlated, on the one hand with the cardio-vascular condition, and on the other with the emotional predisposition, an excellent indication would be given, not only of the existence of staleness or fatigue, but of the general emotional characteristics of the aviator. Major MacLake has shown this to be the case. He has described in detail the various phases of the reaction of the capillaries in the skin when stimulated mechanically, and has pointed out the relation of these changes to the emotional status and, if they are present, to the symptoms of physical and mental fatigue. Records of these same phenomena, modified to meet the special conditions existing in children, should be made regularly during the school period.

After we have gained, by a careful scrutiny of the behavior, some idea of the general stability of the processes of organization, watching particularly the co-ordination and completeness of the adjustments, we may be much aided in our task of a comprehensive study of the child by noting the rate of growth as recorded in stature and weight.\* Interesting comparisons have shown that between the seventh and fifteenth year there should be, in both boys and girls, besides the increase in weight, considerable variation in the rate of gain. There is, as we should expect, a

\* Robertson, T. B., "The Variability of the Weight and Stature of School Children, and Its Relationship to the Physical Welfare," *Am. J. Physiol.*, XLI, p. 547.

corresponding increase in stature, but the variation of this is less than that in weight. The stature curve is a better criterion for any departure from the average, called normal, than is the weight curve. Considerable light may be thrown upon the effects of the environment, including dietetic and living conditions, by such a sensitive indicator as the weight. If at the time a child has reached school age the environmental influences are particularly unfavorable, they may be plainly reflected in the deficiency of both weight and stature; making due allowance, of course, for what seem to be inherited tendencies.

Making use of these lines of investigation, it has been asserted that, as a rule, heavy and tall boys of early development seem to succeed better in their school work than the boys becoming heavy and tall at a later period. According to this supposition the light-weight boys, however, who develop slowly mentally, eventually rank higher than do those who during the early or medium period have had greater mental capacity; short boys developing slowly not ranking high. The boys both of medium size and representing a medium degree of maturity are very difficult to classify, but, as far as real ability goes, the majority apparently occupy a middle group.\* Of course there are exceptions to this rule.

The results of these studies deserve consideration and should be familiar to all persons engaged in the solution of educational problems, because if further study corroborates these findings, they should have great weight in the determination of the amount of discipline essential for the best results. Then we need not hesitate to push along, without fear of injury, the tall heavy boys who rapidly attain their full mental development, while the tall thin boy who is slow to gain control of his higher intellectual processes should be handled without pushing.

In a certain sense every period of age has special features worthy of close investigation, but for the present our empha-

\* Stewart, S. F., "Physical and School Standing of Boys," *J. Ed. Psychol.*, 1916, VII, no. 7.

sis is upon this one of development when unsuitable forms of discipline may lead to very disastrous results, not only in the perversion and curtailment of function of various organs, but in serious disorders of behavior. If the growth process is interfered with, the increased sensitivity immediately starts a whole series of compensatory reactions which eventually give a definite cast to the entire personality. Under the stress of modern life which affects the early years of childhood, the difficulties of adjustment are probably greater proportionately than those encountered at any other time. When a child does not gain in weight and height during these years, a very careful study should be made to determine whether the form of education selected is not only unsuccessful but a decided menace.

All the mental reactions of children should be considered in the light of the reciprocal relations they bear to responses both of a higher and a lower order. A series of association tests may be used with this special object in view,\* and from the results of applying these methods, an appraisal of a number of different cerebral functions may be drawn up. With this information at hand, we may start out intelligently to assist in stimulating new interests and to extend the range of adaptation in a way that will not be injurious to the adjusting mechanisms. For example, if a student when replying to a question shows a tendency to confuse the issue and to resort to circumlocution, we have quite a different pedagogic problem to discuss from that of a boy inclined to snap out his answers and cut short replies. It is not only the conscious processes that are concerned in these replies; the irrelevant reply to a question may be due to lack of co-ordination at the reflex level, or a vague response may indicate insufficiency of automatic mechanisms.

When we reach that time which marks the beginning of formal education, namely, the school period, the mental capacity of the child is the centre of interest for the teacher's efforts. Consideration of the biological forces at work,

\* Downey, J. E., "The Association Test as a Substitute for the Quiz School," *School and Society*, July 7, 1917, VI, no. 132, p. 23.

however, in directing the formation of character and temperament, shows that those collectively described as mental—although upon superficial examination appearing to be the more striking—in reality play a comparatively unimportant rôle in the general synthesis of the activities. But standards of measurement by which we estimate the mental capacity of children should doubtless be registered, in order to permit a biological study to be made. Such graded tests as those used in the Binet-Simon methods of examination are likely, unless used by experienced physicians, to lead us astray. Like most other tools, the value of these methods is in direct proportion to the experience of those who employ them, and they should never be applied indiscriminately, as is now only too often the case.

In the accompanying inventory of educational progress, the information sought represents the minimum that a teacher should know in regard to a pupil if a rational attempt is to be made to give the essentials of an education. Any intelligent teacher, within a period of two or three months, could be taught to make these superficial examinations describing the chief physical and mental characteristics at the entrance to the grammar school, high school, and college or university. When the information asked for in this inventory is obtained it is possible for the teacher to form a general idea of the capacity, traits, and predispositions of the student; and then, starting from this basis to work out some plan which will insure formal and rational development.

#### INVENTORY OF EDUCATIONAL PROGRESS AT THREE IMPORTANT EPOCHS

1. Beginning of school period.
 

<i>a.</i> Sex	Age	Weight
<i>b.</i> General physical and emotional characteristics.		
<i>c.</i> Capacity to stand and sit quietly.		
<i>d.</i> Precision and co-ordination of spontaneous and voluntary movements.		
<i>e.</i> Evidences of eye, ear, and motor mindedness.		
<i>f.</i> Signs of intelligent curiosity.		

- g.* Fatiguableness, mental and physical. (Cardio-vascular rating and dermatographia.)
  - h.* Signs of unusual or capricious development.
2. Beginning of high-school period.
- a.* Physical, emotional, and intellectual signs of femininity or masculinity.
  - b.* Relation of increase of weight, stature, and mental development.
  - c.* Hyper- or hypokinetic.
  - d.* Signs of rational self-confidence.
  - e.* Plenty of reserve energy (physical and mental), or easily fatigued?
  - f.* Tendency to face squarely or to dodge critical situations.
  - g.* What is the character of reaction to unpreparedness, or to unequalness to a given situation.
  - h.* Special interests and aptitudes.
3. Entrance to college or university.
- a.* Relation of weight, stature, and mental development.
  - b.* Pronounced masculine or feminine qualities.
  - c.* Purpose stated by student for entering college.
  - d.* General mental attitude toward life.
  - e.* Evidences of emotional stability or instability.
  - f.* Signs of healthy independence.
  - g.* Ability to observe and to record observations.
  - h.* Control exercised over wishful-thinking.
  - i.* Appreciation of emotional and mental qualities essential for culture.
  - j.* Defense reactions to compensate for inadequacy.

The results of the examinations conducted with a view to determining the physical efficiency and resistance to fatigue should form an important part of the examination at these three periods.

A few general notes upon the physical and emotional characteristics of the boy or girl entering school would be of greatest value. Even the general impressions of the intelligent teacher who does not possess special technical ability for making examinations of this character could be utilized to great advantage. In the majority of children it would be possible to note the individual characteristics and form some idea of the kind of education that will be needed for strengthening desirable and repressing or compensating for undesirable qualities. A good deal can be told about the emotional characteristics by watching a child closely and noting its capacity for standing and sitting quietly. If the tension caused by being observed easily relaxes there is evidence of the presence of reserve energy.

In the same way, notes upon the precision and degree of co-ordination of both spontaneous and voluntary movements have a special importance. The general carriage, the various postures, the facial expressions, and the precision with which complicated movements are carried out throw a good deal of light not only upon the temperament but upon the character.

Although it is not an easy matter to distinguish whether a child is a visualist or an auditive, some indication may be given as to which one of the senses seems to be the chief avenue of approach in gaining and maintaining the attention. It is also desirable to secure some indication of the degree of intelligent curiosity, since this quality should be scrupulously cultivated and not repressed, in passing through the educational mill.

The question of mental and physical fatigableness is important, not only in relation to the performance of mental work but in its bearing upon the entire personality. A child who shows signs of fatigue soon forms the habit of slacking and in this way a great variety of undesirable reactions may be built up. Any indication of unusual or capricious development calls for the advice of a specialist.

Before entering the high school this examination should be still further supplemented, as is indicated in the inventory, and a more extended examination should be made upon the entrance to the college or university. This plan for examinations is not in any sense a rigid one and may be easily modified as occasion demands, but, as has already been said, without making some such observations, intelligent assistance cannot be given to the student by the teacher. It is certainly one advantage of making this biological examination that it gives the teacher a personal interest in a student which could not be acquired otherwise, and at the same time it substitutes a biological conception of the process for the academic view that has been responsible for so much misdirection of energy and so many tragic failures in living.

The kind of examination of mental qualities we have in



mind as being entirely practical and not too complicated to be undertaken by persons without the training of specialists, does, however, require the exercise of patience and common sense. Teachers should try to estimate the emotional and intellectual potentialities of each member of the class, and the record of these impressions should form the basis for giving assistance to every boy and girl in developing their special capacities.

Consider the advantages to the child and the relief from dreary routine afforded to the teacher engaged in giving instruction in spelling, if the psychologic as well as physiologic factors responsible for the pupil's success or failure were taken into consideration. When viewed in this light each case would present interesting problems involving the consideration of facts of prime importance in education. Inquiry has shown, for example, that good spellers seem to have more accurate visual memories and a ready capacity for associating these with the mechanisms concerned in hearing and in the expression of speech. All such information when supplemented and co-ordinated will lead to great improvement in the practice of teaching.\* This is merely one illustration of what might be accomplished if we could secure rational oversight in directing the behavior of human beings.

Much also would be gained if those special emotional qualities responsible for the resiliency of the personality could be often tested. For example, by watching the surprise, pleasure, pain, etc., indicated in the facial expression, general pose, and character of the responses called forth by impinging stimuli, we could obtain an excellent idea of the personal adaptability. It is also comparatively easy to tell when a child begins to suffer from abnormally repressed emotional reactions. In dealing with vital problems not much experience is needed to recognize the biologic importance of vigor and happiness in early childhood. Definite pleasure in coping with difficult situations is plainly demonstrated by the amount of joy displayed, and is readily

\* Howell, Hopson, Washburn, *Am. J. Psychol.*, 1917, XXVII, no. 1, p. 157.

gauged; while naturalness and unaffectedness of the action also combine to give an idea of the adjusting capacity. The happy disposition, not in unduly exhilarated form, but the affective disposition, which clearly indicates that its possessor is not falling behind in efforts to make new and often difficult adjustments, is a sign of great value.

Careful observations are also desirable in regard to the reactions of children when they are called upon to act in an emergency. Here the emotional stability is under stress. If the grooves worn by habitual affective responses distribute the energy properly for its release in behavior, we need trouble very little about the higher intellectual processes, because these will take care of themselves. The child who shows an unusual anxiety about the performance of ordinary duties should be very carefully handled in school. The affective balance may be so much disturbed that there is inclination to rush ahead without waiting for the foreseen difficulty to be formulated. Such overeagerness should be reduced, not by repression, but, as far as possible, by getting rid of the causes responsible for it. The exceedingly active mentality and astonishing nimbleness of the same neurotic children who try to anticipate all attacks, and the skill displayed in developing protective reactions, are danger-signals that the nervous system is being driven too hard and too fast.

The character and amount of independence of action possessed by a child are subjects of much interest. Any intelligent person can learn to draw the distinction between the normal reasonable wish to "paddle one's own canoe" and a neurotic craving for relief from any form of restraint. Far more attention than such symptoms usually attract should be given to helping children to lay the foundations of real and not fictitious freedom. The kind of freedom to be diligently sought for is one in which a joyous contentment is a predominating feature, while early release should be gained from any indication that such emotional reactions as grief, worry, fretfulness, excessive apprehensiveness, or definite fears are becoming "fixed." The manner in

which students react to favorable or unfavorable environment is of far more importance as an indication of the general trend of activities than is an analysis of the intellectual processes.

In order to prevent the formation of bad mental habits and to cultivate those which make for efficiency and happiness, it is necessary to preserve a proper balance between the degree of stimulation and the responses, or between the amount of work undertaken and accomplished and the period of relaxation. Processes initiated should, whenever possible, lead to some accomplished end. The fullest opportunity should be given even to very young children to associate reality with mental images. It is possible in connection with the simpler forms of reaction occurring in very young children to notice the satisfaction derived from the association of the mental image with some real situation. This may be observed even in babies in their efforts to pick up objects and hold them and in the simpler acts connected with the various forms of adjustment. It is from the success obtained in accomplishment of acts often seemingly without any definite purpose that the important sense of confidence develops. It is interesting to note in infants, as the range of adaptation is extended, how marked the feeling of confidence becomes in the performance of practically every act. Even during infancy the basis of an unsocial attitude, or the shut-in type of personality, may be laid if the reaction is not accompanied by a feeling of satisfaction. One of the most important points to be kept in mind in examining children who are about to begin their formal education, is to determine to what extent a normal and enduring sense of achievement affects effort. If the habit has not been formed of associating successful achievement with effort, the foundations of an education have not been laid. When this defect exists it should be the duty of the teacher to assist the child to form a new series of associations. Burnham\* has called attention to the importance

\* Burnham, Wm. H., "Success and Failure as Conditions of Mental Health," *Mental Hygiene*, July, III, p. 387.

of success and failure as conditions of mental health, and has also pointed out some of the pathetic tragedies of childhood as well as adult years that result from failure to observe these conditions. Both home and school should provide plenty of legitimate activities for realizing successful social adaptations. Unless this precaution is observed, young people will obtain a degree of satisfaction of a temporary character in ways that are either antisocial or otherwise deleterious. We cannot begin too early to prevent the development of a gulf between ideals and actual performance. For this reason it is important to form the habit early of facing definite concrete situations, of not undertaking impossible tasks, of living—and of following the rule of living—one day at a time, a rule that Sir William Osler called the “freshest, the oldest, the usefulest, of all the rules of life.” In striving for success it is very important not to place students in conditions which lead to overstimulation without relaxation or give rise to an abnormal degree of consciousness of success and the development of the unfortunate complexes which later in life split up the personality and prevent its organization into a harmonious working unit. There is no doubt that an occasional failure is beneficial, as it prevents the development of overconfidence and shows a person where the weak spots in character lie.

The practice of driving a pupil extends through our entire educational system—from top to bottom. We have such blind faith in the virtues of undigested stores of information gathered from books that practically little thought is taken of the probabilities for dwarfing character, curtailing interests, and inducing an exaggerated egotism during the periods in school and college when the majority of subjects are poorly taught and so many demands are made upon the pupils' attention that no time is given to the foundation of good mental habits and the cultivation of the power to do one thing well.

We have remained blind to the real issue so long that many serious consequences and complications have arisen.

A college that made the best use of its opportunities would soon become an institution devoted largely to the correction of the bad mental habits formed during the school period and to the awakening of interests stifled by a conventional system of pedagogy. The very fact that there are students who develop intellectual interests in the face of such difficulties should make us decidedly optimistic in regard to the mental development of our race when a rational system of education can be put into practice.

During the early school period careful watch should be kept upon the order and extent to which the social instincts develop. Is there evidence of the budding of communal consciousness or are there signs of social antipathies, or of schism and opposition? Even before the years of puberty special phases of the personality may stand out in sharp relief, and the trained observer should have little difficulty in recognizing undesirable traits, which are generally more easily distinguished than the good qualities, because the latter are more often merged into the other activities and therefore attract less attention.

At puberty an inventory—generally a fairly accurate one, too—of our stock in living, is made for us by nature. Then both good and bad qualities begin to stand out more plainly; some traits, which were not suspected, shoot into prominence, while others, supposed to exist, are shown up as merely products of the imagination. Closely associated with these transformations are the phenomena more directly connected with sexual maturity.

The periods of pubescence and nubility vary within wide limits, determined partly by inherited and partly by environmental factors. Race, food, and climate represent a few of the influences that incite or inhibit special functions and so lead to profound changes in the shaping of the personality. It is well known that in the case of Jews, the children become both sexually and mentally mature at an earlier age than do the youth of other highly civilized races.\*

\* Kaznelson, P., "Ueber einige Rassenmerkmale des jüdischen Volkes," *Arch. f. Rassen u. Gesellsch. Biol.*, 1913, IV, p. 484.

To what extent this premature development is directly dependent upon social conditions, and the bearing this may have upon training of the personality, are interesting subjects for investigation.

During the first part of adolescence, particular attention should be paid to the direction and strength of the emotional currents. The centre of interests seems, in some cases, to be suddenly shifted from a restricted circle, the contents of which have been directly related to self—a marked characteristic of childhood—to a rapidly expanding environment. A few psychologists draw a sharp line between the mental life before and after the onset of puberty, but it has always seemed unfortunate to the writer that such an artificial distinction should be made. There is no reversion in the mental attitude, as some psychologists maintain. The egotism of the child is due to the limitations imposed by nature, an incapacity to exchange an interest in objects and persons of the immediate vicinity for those at a distance. As soon as the new impulses begin to quicken the affective life, the range of adaptability is extended, but no right-about facing has taken place. Any decided change sufficient to make probable the turn of the tide of the activities or the beginning of a revulsion should point to the existence of conflicts and departures from the normal functions. The new set of ideas and sentiments cropping up at this time should be in no wise irreconcilable with what has been there before. Sometimes, in a certain type of boy or girl, the expansion is so rapid and extensive that the impression is produced of something specifically different having entered into his or her life. But this notion only leads to false conclusions as to the nature of the actual occurrences at this important epoch in life.

Various reactions are, of course, closely tied up with the adolescent affections. In some young people the exacerbation of special interests, those referring to the selection of ideals of conduct or to the choice of a profession, temporarily side-track thoughts about the opposite sex. Under such conditions a strong inclination to avoid meeting friends, or

a vague wish to find isolation may dominate behavior; and excuses are often trumped up to satisfy both self and others for the apparent aloofness. The deliberate nursing of such special trends leads many to convent, cloister, or later to a sanatorium for the treatment of nervous disorders.

Sometimes the first evidence of a serious disturbance may be noticed in the increased activities of the imagination called to the defense of a personality, which has no other means of resisting the strain than by a feeble attempt to adjust life to meet the new conditions. As has been said, it is vitally important that young people should prefer the romance of reality to the task of trying to prove the reality of romance. We see it in the boy or girl making an unusual effort to be thought well of, but whose lack of sincerity in behavior, or straining for effect soon becomes apparent. Very often the child tries to occupy the centre of the stage and personal experiences are described in a way calculated to attract unusual notice. It is this disposition that inevitably leads to lying; and once an untruth is told the way is opened for a continuation of this habit. Often, too, we may be amused by the verbal exaggerations of young people and fail entirely to see, in these voluntary misrepresentations of the truth, the signs of the real condition below the surface.

It would be quite possible for a teacher with right ideals and proper training for the work to lead a child who is forming these undesirable habits to recognize the significance of the mechanisms and to effect a satisfactory readjustment. Such a teacher would be much more solicitous about preparing students to meet the issues of life squarely than in assisting them merely to acquire sufficient information to pass examinations, and would be quick to furnish the kind of help that in later years should avoid for them the necessity of settling at inopportune moments old accounts haunting the mind like spectres and ever threatening disappointment and despair.

It is already high time that the causes precipitating conflicts in the adolescent period should be thoroughly studied,

if we can ever hope to aid men to gain intelligent control over the lower instincts, or to secure a successful domestication of traits inherited from our primitive ancestors. As yet we have hardly made a start in this direction. The sorrows of a Werther, or the struggles of a Marie Bashkertseff may interest us, but mere descriptions of such conflicts neither make a complete analysis nor lead to the discovery of their causes.

One effect of any conflict is that both attention and interest may be narrowly circumscribed. The possibilities of normal expansions and the absence of conflicting motives account for a healthy curiosity in a boy with an impelling desire to increase his store of knowledge. This mental attitude quickly changes as soon as its possessor undergoes the system devised for pouring in information without giving time for its assimilation and orderly arrangement.

This whole subject of attention and interest, so important for the welfare of the adolescent, has, like many others we have mentioned, been treated from an exceedingly narrow view-point. We cannot understand what is taking place when the attention is either focussed or relaxed, if we consider only the conscious processes. Psychologists now admit that the psychologic phase of adjustment represents merely one incident of secondary importance.

On the neurologic side, the mechanisms called into play in focussing the attention represent a very wide-spread cortical activity; but these centres are themselves conditioned by subcortical areas.\* And beyond these, at the basis of the phenomena of attention, are the affective states already conditioned by the involuntary nervous system. We have already seen how any understanding of these mechanisms must involve the study of the activity of a number of organs, such as the ductless glands. In connection with each shift in attention there is not only a marvellous degree of complexity but a remarkable delicacy in the reactions. Then, too, the character of the stimulus has a direct effect upon the pattern, a simple reaction call-

\* Woodrow, H., "The Faculty of Attention," *J. Exper. Psychol.*, 1916.



ing forth quite a different combination from that concerned in voluntary choice.

Some authorities believe that the motor centres themselves are not actively innervated during the preparatory interval immediately preceding the act of focussing. Others recognize the apparent existence of a certain predisposition of the entire motor system favorable for adjustment. Efforts to raise the focussing power should be directed toward improving the general health and so securing the vigor and increased tension essential.

Very often efforts to interest students in a certain subject result only in an unfortunate antipathy to it. This condition may be due to various causes in which the affective states have much to do. The reaction associated with delay in understanding what has been said is one of the commonest of these reasons. On this account care must be taken to make sure both that the meaning is plain and the first principles of the subject are understood. Lack of understanding is responsible for much of the indifference to learning of students in schools and colleges. A distinguished mathematician has said that "a few children are born mentally deficient, but a number are gradually made so by the efforts made to train their growing faculties." Any boy or girl who, while in school, is deprived of the comfort and assurance derived from an understanding of the lesson will rapidly build up defense reactions. Such a child will, as we have already noted in discussing the basis of honesty, soon begin to resort to subterfuge if the constant strain of having to make good in examinations is not relaxed.

Each intellectual interest should become the nucleus of a group of reactions. Education hitherto has overlooked this bare fact. Not only do the children fail to see the practical value of what they learn, but, because they are kept in ignorance of any connection between what they learn and life, they find the process of acquiring information reduced to the brutal task of memorizing facts. That spirit which in later life should express itself as pride in work or profession, is carefully eliminated and consequently no

opportunity is provided for the emotional appeal, which if rightly directed, is so beneficial in fixing ideas and in creating the stimuli needed for the performance of good work.

Scholastic pedantry, which is such an obnoxious influence, is particularly destructive of interests; and the meddling interference of persons with no idea of the insidious and deadly effect of limiting the conception of education to purveying information without giving the student some notion of how this expenditure of effort is related to the solution of the problems in his own life, should be avoided.

We are very apt to be resentful when compelled to follow any line of action suggested in order to "improve our minds"; but many American schools and particularly the private ones present a curriculum, as well as methods of instruction, which suggest the willingness of adults to have a young person take the medicine refused by his elders. The argument of the need for young people to learn to do unpleasant tasks cannot be considered as a reason for the continuance of the present deplorable conditions in schools and colleges. There are too many great problems in the world awaiting solution and calling for the development of broad sympathies and intelligent methods of attack to justify the risk our present school system runs of dwarfing a personality by deliberately choosing a field for the expenditure of energy that has been restricted and made unattractive as the result of our stupidity.

In planning to encourage a budding interest it is essential, in order to avoid antipathies, to know how they spring up and the character of the soil favorable to their development. Young people should have plenty of opportunity to discharge their energy and find definite form of expression for their mental exertions. When living conditions were less complicated than at present and people were compelled to do more for themselves, the various occupations connected with the work of the household and farm life or the manual work in trades supplied the necessary outlets for motor activities. Antipathies, both to subjects and persons, often spring up as the result of the emotional dis-

orders induced when the process of thinking is treated even temporarily as if it had no relation to feeling and acting.

A condition of ambivalence may result when an idea is neither accepted nor rejected by the mind because the waves in the emotional life effectually block expression in action. An appeal to reason under this condition is of no avail, since the underlying currents lack the strength needed to swing the balance. Each time a student develops some inexplicable antipathy or unusual sympathy it would be worth while to trace these dispositions back to their starting-point.\*

When we have occasion to look through any of the leading histories of education,† we are struck by the fact that the idea of training the intellect, without account being taken of what happens in the lower levels, seems to have filled the minds of educators until recently so completely as to make them oblivious of the vital issues of their subject. The process of what was called character-building was supposed to be controlled by the great attention devoted to the conscious reactions. The development of the mechanisms of a good or bad character was considered to be largely a matter of volition, and was supposed to be within the reach of every one capable of acquiring a knowledge of the best in present and past systems largely scholastic in type. This unfortunate misapprehension, exaggerating the importance of unassimilated information and ignoring entirely individual physiologic characteristics, still has its representatives who are much more concerned in debasing the classics by using them to advertise a pedantic and selfish culture than in assisting students to acquire success in living. The tendency of defining education in terms of knowledge only has had a disastrous effect and brought much misery into the world. There are pedagogues to-day who believe it possible to organize complex brain processes merely by furnishing a supply of information; a theory

\* Kollarits, J., "Ueber Sympathien und Antipathien, Hass und Liebe bei nervös und nicht nervösen Menschen," *Ztschr. f. d. gesamt. Neurol. u. Psychol.*, 1916, XXXII, Hft. 2, 3.

† Monroe, P., *Text-Book on the History of Education*.

that for years has tried the credulity of the public's faith in education and provided a fetich for one type of schoolmaster to worship. The desire to establish a special cult has been responsible for many of the defects of our present system of education. According to a few devotees, the aim of the purely cultural is to form a personality apart from the world; to be in it but not of it; instead of aiming to extend a person's contacts with the world, it limits them. The audacity of depending upon the influence exerted in the conscious processes to shape a man's entire personality is indeed great!\*

Another very serious mistake made in both schools and colleges is the attempt to establish uniform standards and thus to make all pupils alike. The startling degree of uniformity and mediocrity attained, particularly in the college, is evidence of the deadening influences of grades and tests. So far American educators have shown very little regard for cultivating the influences which tend to strengthen original thinking and the formation of independent judgments upon intellectual subjects. Now that more attention is being paid to individual differences, we may hope for a decided change in opinion in regard to the conventional standardization of thinking which has been such a hindrance to progress.†

Putnam‡ has drawn our attention to the useful lesson taught by Hughlings Jackson in pointing out the biologic significance of many habits which, supposed to be indicative of defects and imperfect adjustments, are in reality only signs of a struggle of the organism to reassert itself. As illustrative of this we find cases of students who, as a means of protection, fall into a state of intellectual indifference, or, if they belong to the neurotic type, easily acquire the habit of anxiety. In either case the substitution of good

\* Hamilton, W. T., "The State High School," *School and Society*, 1916, IV, p. 875.

† Woody, C., "Tests and Measures in the School Room and Their Value to the Teacher," *School and Society*, 1917, VI, p. 61.

‡ Putnam, James Hamilton, *Human Motives*, Mind and Health Series (Little, Brown & Co., Boston, 1915).

for bad habits is impossible unless the causes are discernible. In the latter case, however, we should probably find that the undesirable trait is the result of a conflict, some uncongenial influence, that prevents complete and successful adjustment; or it may follow the effort to put up an appearance of being happy and contented. Again, some unpleasant incident may throw a young person into a state of anxious expectancy, keeping him constantly on the *qui vive* against a surprise attack. As a consequence of this apprehension, the tension is seldom relaxed, particularly in the presence of the immediate family and intimate friends, the true self being revealed only when away from home or while with strangers. When young people show these symptoms we are accustomed to ascribe their actions to motiveless impulses and forms of behavior showing little co-ordination. But on closer inspection it becomes clear that even this kind of behavior is a rationalization and an attempt to square up with the world.

The question may well be asked as to the treatment of boys and girls with these particular qualities, developed as the result of not having faced unpleasant and difficult situations squarely. No satisfactory answer can be given in a brief discussion. Each case must be examined and handled on its own merits. Too much talking—perhaps the pupil would say lecturing—on the part of the teacher, is certainly undesirable and may only exaggerate the fault. When possible, life should be allowed to drop to the level where the individual is capable of adjusting, and where for a time he does not feel at all behind the game. In the case of children brought up in the city a quiet country life is eminently desirable, and all strains in any way responsible for the inadequacy expressed in egotism and self-assertion should be relieved.

One of the sanest and safest methods of assisting in the development of stability of character and of a desirable quality and quantity of independence of thought and action, is to give children a love of nature. Nature-study, familiarizing children with the lives of common plants and

animals, teaching them how to observe and record their observations, both in writing and by making sketches, should be required in all schools. Nature-study may be effectively combined with sketching so that even children without any definite artistic traits may be taught how to make rough sketches of the objects they see on their walks. This is a very effective way not only for establishing good mental habits, and developing the capacity of accurate observations, but for introducing a chain of interests that may have a profound influence in determining the whole mental attitude in regard to the significance and purpose of life.

To bring about any co-ordination between thinking, feeling, and action, an essential of education, the student should be made first to realize that education is a means of getting into closer touch with the real problems connected with living, and then emphasis may be laid upon the need of enlisting all the forces, emotional and intellectual, in the effort to adjust life with satisfaction.

Teachers sometimes, in speaking to students about educational values, assume an apologetic attitude; and this is a great mistake. Nothing could be more disastrous to the stimulation of higher interests and to the development of broad sympathies than this unfortunate attitude—one that has become constantly more characteristic of American education. There is an increasing tendency to view with indifference the divorce so common between, on the one side, intellectual ambitions and aims and, on the other side, the underlying emotional trends. It is believed, for example, that young men can well afford to indulge repeatedly in emotional outbursts in support of the college in which they are enrolled, with no detriment in after life to the awakening of higher interests. It is assumed that intellectual interests can be quickly created and strengthened with the purpose of getting some great object before the mind in such an emotional setting that it will absorb all the energies and create a guiding motive in life.

This, of course, is impossible, because the habits neces-

sary to concentrate all the energy available to adjust at the higher levels cannot be cultivated at a moment's notice. Those who have passed through college and school periods with no experience of any real intellectual awakening, may later in life become absorbed in fads, or take an amateur interest in a number of different subjects, but, as a rule, they fail altogether to develop either extensive or deep interests. By reason of the tendency toward a split-up personality many graduates of American universities do not develop mentally to any extent after graduation. The very fact that the real intellectual issues of life have never been squarely faced and that teachers have seldom dared to call attention to the genuine seriousness of the responsibilities connected with living, has had a disastrous effect in restricting thought by its interference with the emotional states. The habit is formed early of dodging issues, but the related mental disposition is usually preserved intact until the day of graduation, when the effort is made, certainly under pressure and therefore unsatisfactorily, of substituting reality for a make-believe world.

Undoubtedly the raw material often of the best quality exists, but in American schools and colleges, under our present system, the energies are so scattered and so little opportunity is given to concentrate the total capacity in a prolonged effort in one direction, that we must expect only an abundant display of mediocrity. No one can think long and hard upon any one subject unless *all* the energies are consolidated by the emotions in one persistent effort. For this reason it is very desirable that the attempt should be made to change the atmosphere in most of our private and public schools so that the students may not be encouraged to regard sports as the essential offset to unpleasant mental work. A definite sense of pleasure should be cultivated in connection with mental effort. Relatively few Americans have acquired the art of taking pleasure in work, and this defect has disastrous consequence for the individual as well as the nation.

In selecting methods adapted to the proper organization of the emotions we are at once brought to the consideration of a closely allied topic, long a subject of interest to educators; namely, the establishment and realization of cultural ideals. We cannot discuss questions of education, especially of the so-called higher forms, without referring to the old controversy as to the definition of culture and the selection of methods adapted to imparting cultural influences. The mistake is frequently made of discussing the subject of culture as if it were an academic and not a biological problem. The essentials of culture can be much more easily and clearly formulated in biological terms than in the usual scholastic phraseology. The characteristic attitudes of the cultured mind depend as much, if not more, upon the emotional than upon the intellectual processes. This obvious fact is generally forgotten or ignored by those who take pleasure in the mere sound of words and experience a great power in them. The natural simplicity, directness, freedom from prejudice, broad interest, and intelligent sympathy of a cultured person are, to a great extent, the result of influences lying far outside the field of consciousness, and expressed in the affective life. The scholastic training has demonstrated conclusively that these qualities are very rarely the result of academic influences; so rarely, in fact, that for them it is hardly worth perpetuating the present scholastic system in which the failures are much in excess of even the partial successes. The intelligent seriousness of the cultured person's view of life is the product of a great number of the biologic forces dominating character. Among these are the desire and emotional preparedness to recognize and face reality, and the willingness not to repress unpleasant truths. In order to preserve the fine balance of mind requisite for recognizing the best that has been thought and expressed in literature and art there must be a freedom from the mysticism which tries to substitute for a genuine culture a mere ritual advertised in mellifluous euphuisms.



The estimate of the efficacy of the present educational methods is sure to be a conservative one if the observer has ever reflected upon the insignificance and impotence of the results so far attained in comparison with the magnitude of the educational task now before man.

## CHAPTER XIV

### THE STUDY OF MAN IN RELATION TO THE PROGRESS OF CIVILIZATION

THE hope for the progress of civilization to-day has probably a more substantial basis to rest upon than at any other period in the history of the human race. Measure as we may the advance the world has made in the invention of mechanical appliances and in scientific achievements, in the greater interest in sociological methods and in the improvements in the conditions of living, to those who estimate progress by the law of the greatest happiness to the greatest number, one other advance has recently come to be of immense import for the furtherance of that happiness: man, driven largely by the events of the past six years, is to-day at the point of deciding whether he really cares to know himself, and whether he wishes to discover the laws controlling his emotional life, directing his aspirations, and extending his intelligence. The shock of war and its attendant misery should not be allowed to shake our confidence in the latent possibilities of this new attitude of man toward himself, nor should we permit any signs of disaster to obscure the fact that very old problems of living have recently been presented to our attention, not only in new forms but in a manner to suggest a rational basis for belief in their ultimate successful solution. A brief résumé of the evidence favorable for this present outlook will suggest practical applications of this knowledge that should benefit a world now discouraged with only partial success or often with downright failure.\*

It is obvious that we are still paying heavily for the blundering attempts to forward civilization by means chosen very much at random. Unforeseen accidents have demon-

\* White, W. A., *Thoughts of a Psychiatrist on the War and After* (Paul F. Hoeber, New York, 1919).

strated the fallacy that special theories of salvation are infallible as guides; while war has precipitated its disasters upon nations as an ominous warning that present methods of dealing with human problems must change. We cannot afford to wait again in indifference until obsessions and passions shall have subjugated reason to such a degree that the fate of civilization will once more hang in the balance while another world tragedy is being enacted. Ignorance of human nature has made it impossible to adopt a practical programme for securing peace and avoiding war; and therefore to-day an appalling list of casualties, much social discontent, and a disheartening lack of genuine self-independence confront the world. "It is indeed," says Parmelee, "a pitiful sight to watch mankind grope and stumble toward the goal it has unconsciously set before itself, namely, the complete and satisfactory expression of human nature."\*

War has created an imperative demand for some solid foundation upon which the reorganization of society may be begun. For thousands of years man has drifted along, paying little heed to the analysis of his own moods and dispositions, and disregarding the mechanisms determining character. Nor has he taken much trouble to trace the genesis of impulse, to ascertain the limits of his emotional control, or to understand the currents of his wish-directed thoughts. For this stupid neglect he has reaped the whirlwind of passion and a magnitude of disaster never paralleled in the history of mankind. As a consequence of this almost overwhelming breakdown, the cry is heard that nothing stable remains in our social organization. Old ideals for conduct have been abandoned and to the superficial observer only wreckage of a social organization seems left upon which to build a new structure. But serious reflection tells us that there is no immediate cause for discouragement, because of the many indications of the return of a desire to face squarely this great crisis. This attitude in itself justifies an optimistic outlook for the future.

\* Parmelee, M., *Personality and Conduct*, XIX, p. 269 (Moffat, Yard & Co., New York, 1918).

But this crisis demands that we begin our plan for reconstruction by the unpleasant task of deliberately counting the cost of spasmodic and reckless attempts to guide the human machine by those ignorant alike of its parts and of the laws governing its behavior. Great as this task will doubtless prove, there is no reason for despair. Only recently have the parts of the human machine aroused intelligent curiosity, while but yesterday the behavior of the whole machine became the subject for investigation. It is a matter for congratulation that many of the present defects in our civilization are sins of omission, not of commission, capable of being remedied. Reverses and defeat hitherto should not be considered disasters at all comparable to such as would mark the failure of great and *well-planned* effort. On the contrary, there has been an indifference to the reason for acquainting ourselves with the actual needs of mankind and this indifference has temporarily invited defeat.

Yet in spite of evident reverses progress has been made. Man has gone forward, although it would be difficult to establish the claim that this advance has been the result of deliberate plans and carefully devised methods. Had forethought played a prominent part in directing human activities, man would long ago have made use of the opportunity to find out more about the laws governing the biological processes involved in thinking. As a matter of fact, logic has seldom led in the turmoil of life; it has rather been the surging of impulses from the emotional level that has supplied the driving force. Although political leaders may claim the contrary, our present social customs and institutions are not the product of careful thought and superior intelligence. No extensive knowledge of history is necessary to prove that the great movements that have led to definite progress in civilization have been put forth to meet some emotional demand—a demand so pressing as to require prompt decision and vigorous action. Occasionally man has acted intelligently in meeting the need created by the exigency of the moment, but, while in these more or less

exceptional instances the manner in which the purpose of activity has been fulfilled has suggested the possibility that knowledge of the laws regulating human activity had come through long experience, other events have usually demonstrated that only a most superficial knowledge of man's self was available for use in the emergencies. Of one thing, however, we may be certain: every person who is intelligently endeavoring to become better acquainted with the laws governing human behavior is, in reality, a public benefactor. In so far as he may dig out the primary facts will he add to the quota from which a rational interpretation of history may be made, together with a correct estimate of current events and the ability to forecast with reasonable certainty the future. Historians' claim to our admiration is at present largely based upon the dialectic skill in using the very few data available, since the academic spirit in which the records of human achievement are discussed often evince failure to realize the impossibility, without additional data, of a successful analysis of human phenomena or indeed of any of the mechanisms by which living beings establish and preserve their adjustment with their environment.

It is remarkable how quickly effective remedies for many human ills suggest themselves as soon as attention is focussed upon definite concrete problems of human behavior. Such studies encourage the little-practised art of formulating views of life in terms suggestive of the process of living and not of states of the dead. It is not so much dissatisfaction with reality as ignorance of it that impels people to speculate vaguely and to substitute some dream for reality. The habit once formed of being indefinite, or of contemplating abstractions, increases the difficulty of the realization that life is not a state but a process of adjustment. History as presented is often an excellent illustration of the devitalizing influence that a purely academic view of life has, in taking the breath of life out of many of the records of man's past as well as present actions. So widespread and insidious has this view-point become that it requires considerable patience to insist upon the substitu-

tion of the word "process" for "state" whenever the problems of human behavior are discussed. Just as we lack knowledge to judge of the dead so are we ignorant as to how to judge the living.

In attempting to discuss intelligently any of the great international, educational, social, economic, cultural, or ethical questions now attracting the attention of all civilized people, we are becoming more and more conscious of the fact that a psychological problem must first be attacked and solved before any definite advance can be made. The psychological approach is particularly in evidence in connection with industrial and social problems. As Southard\* clearly indicated, the constant repetition of such phrases as "the human element, personal factors, character analysis, form values, workman's standpoint, workman's ambition, instinct of workmanship, relation of habit, fatigue and efficiency," etc., all point to the growing tendency to consider the problem of human behavior of primary and not secondary importance. Just as it was found necessary to determine the recruit's capacity before assigning him to definite military service, so it is equally desirable to ascertain what the mental qualities of a workman, an employer, a diplomatist, teacher, social or ethical leader are before deciding upon the character of the work which they are fitted to perform. It is fully as important, both for efficiency and morale, to prevent people from undertaking to perform tasks in times of peace for which they are not fitted as it was in time of war to keep those who were inadequate, as a result of emotional or intellectual defects, from taking part in active service. By careful supervision of industry and by giving intelligent assistance to those applying for positions, to find a task to which they are equal, it will be possible, not only to eliminate a great deal of wasted energy, but, of equal importance, to prevent many failures from taking place, and to reduce the number of persons who develop antisocial instincts as the result of occupying posi-

\* Southard, E. E., "The Movement for the Mental Hygiene of Industry," *Mental Hygiene*, Jan., 1920, IV, no. 1.

tions in which it is impossible for them to experience any sense of achievement or satisfaction in the performance of their daily tasks.

We know from the experience gained in the war that those who are emotionally and mentally unfit for active service, if not eliminated, have a pernicious effect upon the morale of the army. The inadequates in peace have a still greater demoralizing influence upon social life. It was possible, however, to find suitable positions for those who were not able to bear the strain of army life, particularly at the front, and to prevent these persons from developing the nervous and mental symptoms sure to follow when their biological capacity has been overtaxed. Similar precautions may be adopted in civil life.

How, then, are we to proceed to make for any community a usable programme aiming at better social conditions? A plan very similar to the following has recently been reprinted by the city of Newark, New Jersey. It diagrams the central importance of the study of human behavior as related to every form of social progress. There is, first, the so-called normal, basic, social group of home, school, and university, about which are grouped the institutions of court, hospital, and homes for the defectives and dependents which represent the abnormal population in that their relations and interests are concerned with that part of society which needs readjustment in mind and body. From the first group we should have centres for study of the foundations of temperament and character, and this information accumulated could be applied to the practical problems of every-day life.\* This same knowledge should then be used to aid those who, filling the institutions of the second group, represent that part of the social organization that has failed to reach a satisfactory adjustment of personal problems by effecting compensatory readjustments. With this plan as guide we see that for the lines of work awaiting at our very doors it is necessary first to ascertain

\* Meyer, Adolf, "Organizing the Community for the Protection of Its Mental Life," *The Survey*, Sept. 18, 1915.

by actual contact, aided by careful analysis, the essentials of temperament and character to-day, before we shall be able to interpret more correctly what man was and has been, and before we may anticipate his future. Analysis of the responses called forth by the immediate exigencies should throw a flood of light on the entire history of the race.

So far so good; but in addition to the cultivation of a biologic habit of visualizing and presenting the problems of human behavior, adequate provision should be made for furthering the work of those who undertake the special art of studying the personality. This could be done to the best advantage in the universities, especially in the medical departments or in institutes founded and equipped for this special purpose. The medical school has at present certain distinct advantages as a centre for investigation of behavior and the various forms of social adaptation. Here the adjustments and relations of the various parts of the machine may be taken into account in endeavoring to analyze the adaptations of the working organism to its environment.

This is not the place to discuss in detail the position psychiatry should occupy in the curriculum of the medical school, but there is urgent need to draw the attention of physicians to the serious consequence of the practical neglect of the study of the personality. Few leaders of the medical profession appreciate the possibilities in the work of the psychiatrist who is engaged in observing the human machine in action. While special workmen devote their attention to the different parts of the machinery, adjust valves, tighten screws, straighten rivets, keep valves clean, and mend or replace broken parts, the engineer who has had practical experience in driving the engine and making notes of its good and bad qualities is the final authority in deciding whether the mechanisms function properly as a whole and accomplish the purpose for which the motor was designed and built. The psychiatrist is the engineer or chauffeur, and we may rightly judge the purpose, although by no means the scope, of his work from his professional title.



The suggestion of pathology in this title should not be permitted to restrict the view of his duties. This broad specialist—and broad he should be in the truest and best sense of the word—Southard has remarked, is engaged “in eradications of evil.”\* If the machine fails to run smoothly on a level, in climbing a hill, or if it acts queerly under sudden stress, the psychiatrist should decide, generally after consultation with authorities upon the functions of the different organs, whether the trouble lies in the machinery and can be remedied, or is the result of an effort to accomplish something for which the machine is not adapted. To make such a decision he must himself be an adept in the art of living. His work in addition to the rectification of poor adjustments should include the field of prevention. We hear frequent expressions of opinions about the relation of physicians to the endeavors to secure social betterment, but in medical schools practically nothing is done to make students and investigators competent to attack along broad and comprehensive lines the problem of human behavior. This indifference is analogous to a manufacturing firm which, engaged in making and repairing motors, exhibits no interest in trying out their product to ascertain whether the motors really run. But it is undoubtedly a fact that physicians, well trained in the investigation of separate organs and detached functions, take little note of the emotional and mental reactions marking the action of the human machine as a unit. The spirit of localism, one of our besetting sins, is similar to this disinclination of the medical profession toward any active interest in the reactions of the living body as a whole; and until the study by it of human behavior becomes a centre of interest and work, there is likely to continue a lack of logical motive in the work of many medical men.

Several reasons suggest the grounds for this indifference among physicians to the human personality. First, there is the entirely superficial doctrine that the practical appli-

\* Southard, E. E., “The Individual versus the Family as the Unit of Interest in Social Work,” *Mental Hygiene*, 1919, III, p. 436.

cation of knowledge to the successful regulation of every-day life is inferior to pure research. Men of this conviction do not admit that the ultimate aim of all knowledge of man should be to ascertain what use he makes of his bodily organs, how successful he is in adjusting to social life; nor do they understand that from the character of his social behavior information may be obtained that indicates his degree of success in regulating his bodily activities. Secondly, others are only interested in studying the human machine in piecemeal fashion, and ignore the fact that the successful regulation of bodily functions is found in the emotional and mental adaptations. And finally, certain students, by reason of repressed memories of personal, unpleasant episodes, resent any suggestion of personality study. It is perhaps worth noting that, while the antagonism seems to be only toward the subject of personality analysis, its underlying motive is purely personal.

Supplementing the special courses of instruction for medical students in clinics and dispensaries devoted to the study of abnormal behavior represented in so-called nervous and mental diseases, there should be opportunities for all those interested in the various phases of personality to learn the biologic method of analysis and the extent to which information obtained may be applied to the solution of problems relating to public and private life. Teachers and social workers would find it very helpful to understand how to go to work to ascertain the essential factors concerned in giving a definite stamp to each personality. Again, to the lawyer this information would be invaluable as a preparation for the comprehension of the nature of the vital processes which he sometimes tries to regulate by the application of legal statutes—efforts illuminating merely as examples of man's inability to grasp the essential problems of life.

The use of more exact method in investigating human nature should lead to results that must eventually modify our opinions upon many current subjects. We should have a better knowledge of the influences operating as social forces to attract man to his fellow men or to drive them

apart. Every clinic affords opportunity for the observation of functions involved in causing the "face-to-face reactions" responsible for the association of individuals in primary groups illustrated by the family or neighborhood.\* Or a thorough investigation of the forces involved in the production of the driving power in the life of a single person might enable us to distinguish many of the factors responsible for the conservatism or radicalism of our views upon the organization of society.† Sufficient opportunity to trace these tendencies in individual cases to their roots, observation of their growth or decrease under different stimuli, would probably develop, among people of apparently diametrically opposed opinions, a better understanding and more liberal appreciation of each one's point of view.

Again, in a clinic it is possible that parents who have already learned the necessity of knowing how to give "first aid" in accidents would cultivate an equally intelligent interest as to situations involving outbursts of temper, sulkiness, disinclination to respond to discipline, or inability to make a rational choice of a means to a livelihood.

It is very obvious that success in giving the right kind of instruction for such hygienic methods of meeting the needs of the emotional and intellectual life must depend upon the available supply of competent instructors. Yet, as we have already inferred, we are to-day without any institution fully equipped to study the principal phases of human behavior. Credit belongs to the University of Michigan, however, for establishing the first psychopathic clinic in the United States, an example followed by Harvard, the Johns Hopkins University, and institutions in one or two other States.

New York, together with many other states, is paying a heavy price for its culpable negligence of the human problem. About one-third of the total annual expenses are now cred-

\* Cooley, *Social Organization*, chaps. III-IV.

† Paton, Stewart, "Mobilizing the Brains of the Nation," *Mental Hygiene*, 1917, I, no. 3.

ited to the care of the insane and feeble-minded. The failure to give the right kind of assistance to those unfortunates of its population who have failed emotionally or intellectually to meet the conditions of their environment is a menace to our civilization far greater than war. And those familiar with the conditions of life in small towns realize the absolute importance of directing the attention of the public to the necessity of dealing with like problems.

Although much in the human personality is still a mystery, nevertheless the proper application of our present knowledge would greatly improve conditions of living to-day. As we look back over the events of the last half-century the conviction is strong that, had a campaign been pushed during those years to educate the people of the world in the principles of mental hygiene, the catastrophe that overwhelmed Europe might either have been averted or limited in its scope.

Suppose that fifty years ago the disruptive forces latent in egotism, in that peculiar form of docility and subservience cultivated by the Germans, had been recognized as fully as to-day as harbingers of a national madness; suppose also that the attention of the entire world had been directed to the dangerous currents flowing beneath the surface of the personality itself, is it not at least conceivable that control comparable to that achieved in handling and preventing contagious diseases might have limited the spread of collective deliria? Germany has furnished a tragic example of the futility of estimating the progress of civilization by intellectual achievements alone. Fifty years of research along the lines of such developments might have shown us the fallacy of overemphasis of man's noetic processes, and would consequently have led to more thorough investigation of the genesis and impulse of the fundamental dynamic forces of mind.\*

We believe, contrary to the general impression, that in Germany it was not the military party that first built the

\* Knowlson, T. Sharper, *Originality. A Popular Study of the Creative Mind* (J. B. Lippincott Co., Philadelphia, 1918).

dam and then opened the flood-gates for the current that finally devastated Europe. We think it rather a supreme belief in the Teutonic noesis and the value of these intellectual operations to effect radical improvements in civilization that has brought about the catastrophic torrents. This same Teutonic noesis, whether expressed in literary, social, scientific, military, or artistic ideals, became a fanatical belief in Germany's power as a centrifugal force; and when the beneficent nature of that force was questioned, German egotism substituted fury for logic.\* Moreover, under the vicious, insidious, constant drive of their academic philosophy, sentiments and homely virtues easily gave way to barbaric instincts, which were indulged in upon the removal of inhibitions consequent upon wishful thinking. Had it not been possible to convince the Germans that such a course must lead to national disaster, to the rest of the world an acquaintance with the principles of mental hygiene would have afforded opportunity to take measures to restrict the spread of the Teutonic psychoses.

In Germany a study has recently been made of the psychopathic characters who have become prominent as revolutionary leaders.† In sixty-six cases fifteen were found to be mentally defective and we are told that not one of the sixty-six was mentally adequate in all directions. These cases included ethically defective psychopaths, hysterical personalities, fanatical psychopaths, and the manic-depressive type of personality.

As an example of the first group was a young man 24 years of age, with a bad family history, who during the period he was in the Volksschule and Gymnasium showed only the average intellectuality and had marked neurotic symptoms. Occasionally he had attacks of vertigo. After leaving the Gymnasium he attended courses in agriculture, but loafed most of the time and was said to have had a bad sexual history and whenever he had the money lived luxuriously. He was not straightforward in his dealings, but as is so often the

\* Santayana, G. A., *opus cit.*, p. 165.

† v. Hentig, Hans, *Aufsätze zur deutschen Revolution* (Springer, Berlin, 1919). Kahn, E., *Zeitsch. f. d. gesamt. Neurol. u. Psychiat.*, H. Jan. 3, 1919, Bd. LII, S. 90.

case boasted a great deal about his own accomplishments while showing a decidedly defective sense of responsibility. Toward the end of the war he entered the army, but did not have a good record, and as soon as the revolution began he took a prominent part in it.

Another case is that of an insurance agent, 31 years of age, who also had a bad family history and was said to have been nervous and restless as a child. In school he showed no particular ability, was married at the age of 21, was arrested several times for alcoholism, was often mentally depressed and seclusive, and had outbreaks of temper. He was discharged from the army on account of eye and ear troubles. He forthwith became a prominent social democrat, although he had never been active before politically. He made a great many speeches, assisted in organizing the republicans in Munich, and attended one of the congresses as an official delegate. He also "lived luxuriously at times," had a shooting affair with another officer, and was finally taken to the psychiatric clinic. Among the fanatical psychopaths was reported the case of one of the leaders of the revolution in south Germany who became Minister-President. He was intelligent but extremely irritable, imaginative, fanatical to a degree, an extreme egotist, a poseur, and a clever maker of phrases.

In periods of great excitement, these psychopathic characters come to the fore and exercise a peculiar influence upon the soul of the crowd. The positive, aggressive traits of the psychopathic leader dominate and control the lower intellectuality of the masses. The emotional life of a crowd of men is very intense but of a primitive type. One result of the high emotional tension introduced by the mass formation is that the relatively simple feelings of individuals represent in combination a powerful aggregation. These primitive feelings produce primitive emotions, and therefore a crowd can be moved only by the appeal to elementary states. It is also true that unconscious impulses to a large extent dominate the mass of people as well as the psychopathic leaders. Leader and crowd are always in a state of tension and restlessness. Both mob and leader react against inertia. As protection against the fear of being thrown upon his own resources the psychopathic quickly develops as a compensatory reaction a certain kind of leadership. In Germany the conditions were exaggerated, since the masses were undernourished, worn out, hopeless, and

demoralized by the war; and as no end was in sight it was easy for these psychopathic characters to dominate the situation. It is incumbent upon us to take cognizance of these facts and use them in order to substitute constructive forces for demoralizing and destructive tendencies.

Yet to-day, although we are aware that there is little to choose between the psychopathic war lord and the equally obsessed, fickle, ambitious "leader of the people," we show a strange indifference to the menace of all that both embody. A Soviet régime has glorified egotism, has accepted the Teutonic belief in one road only to salvation; and such clamorous professors of hate toward all forms of autocracy are now proclaiming the supreme right of labor and the common people. Neither autocrat nor Soviet is capable of making any sacrifice for a really disinterested ideal. Neither has recognized the vital principle of mental hygiene that "civilization does not consist in knowing, but in the manner of acting." Trotsky and Lenine have put forth a programme which, if carried into effect throughout the world, would make it impossible either to distinguish sanity from insanity or to preserve conditions required to make intelligence a dominating force of the personality.

The great question before the world to-day is not the establishment of democracy, nor the settlement of the controversy between labor and capital; it is rather the question as to whether man possesses the intelligence to exercise a rational control over his own acts. There is sufficient knowledge already to make effective the practice of co-operation in the solution of social, national, and racial problems, but do we possess the ability to put this knowledge into practice? Much could be accomplished in removing the obstacles that to-day make co-operation and arbitration difficult. Too much attention has been given to arguments, and little time devoted to the analysis and cultivation of the dispositions favorable for promoting mutual agreements either between individual citizens or nations.\*

\* Paton, Stewart, "The Emotional Unrest, Its Causes and Treatment," *Med. Rec.*, Nov. 15, 1919. *Education in War and Peace* (Paul B. Hoerber, New York, 1920). White, W. A., "Foundations of Psychiatry," 1921.

The entire civilized world is fagged. On all sides we see evidences of the loss of interest in concrete problems. The general irritability, and inability to concentrate attention for any length of time on one subject, the tendency to become suspicious, argumentative, and desirous of radical changes are symptoms that are induced by dissociation in the personality during this twentieth-century stage of evolution. Preparatory to the establishment of law and order, and the adoption of more rational methods of thinking, it is necessary to recognize and treat these symptoms—and upon success in accomplishing this task depends the solution of the social, economic, and international questions of the day as well as the future of civilization.



## INDEX OF NAMES

- Abel, J. J., 253  
Ach, N., 185, 232  
Acqua, C., 280  
Adler, A., 14, 114, 344  
Andral, 272  
Apert, 390  
Appleton, A. B., 88  
Aristotle, 4, 40, 172
- Babbit, 76  
Babinski, J., 356  
Bach, 88  
Bagley, W. B., 278, 282, 299  
Bailey, Pearce, 13  
Bainbridge, F. A., 336  
Baldwin, J. Mark, 32, 77, 150, 183  
Ball, T. B., 369  
Bancroft, J. H., 274  
Barker, L. F., 253, 414  
Bashkertseff, Marie, 430  
Bassett, G. H., 291  
Bayliss, W. M., 41, 222  
Bechterew, H., 68  
Beethoven, 85  
Bernard, Claude, 8, 17  
Berze, 305, 388  
Bickel, H., 256  
Birnbaum, 235  
Bjerre, P., 14  
Bligh, S. M., 368  
Bolton, 74  
Bradby, M. K., 25  
Bradley, 4  
Brifault, Robert, 97, 297, 378  
Broadbent, 73, 131  
Brodmann, K., 76  
Bronner, Augusta F., 370  
Brown, Sanger, 11, 392  
Brown, T. G., 41, 77, 292  
Brown, W. Langdon, 217  
Browne, Sir Thomas, 372  
Buckham, J. W., 325  
Buelow, von, 88  
Burnham, W. H., 301, 425  
Buscera, 267  
Butler, Samuel, 20, 33
- Cabanis, 13  
Campbell, C. M., 27, 51  
Canestrini, 129, 141  
Cannon, W. B., 255  
Carver, A., 167  
Chapin, F. S., 84  
Charcot, 14, 297  
Charron, Pierre, 1, 10  
Chase, H. W., 385  
Chatellier, 31  
Chiaruji, 12  
Child, C. M., 312, 316  
Christian, W. P., 253  
Cicero, 307  
Clarke, Edward, 394  
Clarke, L. Pearce, 298  
Clelia, D., 270  
Clouston, 160  
Cotton, H. A., 258  
Colvin, 279  
Condillac, 17  
Conklin, Edwin G., 28, 311-312  
Cooke, Robert A., 296  
Cooley, 449  
Copernicus, 3  
Cuvier, 52
- Daquin, 12  
Darwin, Charles, 4, 385  
Dastre, 8  
Davenport, C. B., 369, 380, 382, 388, 398  
Dawson, Jean, 34  
Dearborn, G. V., 136, 195  
Descartes, 222  
Devaux, A., 237  
Dewey, John, 77  
Disraeli, 24  
Dolley, D. H., 312  
Donaldson, H. N., 128, 291  
Douglas, L., 35, 172  
Downey, 419  
Draper, George, 369  
Du Bois, P., 273  
Dunlap, Knight, 22, 181

- Duprat, G., 4  
 Du Sablon, 254  
 Edinger, L., 79  
 Ehrenberg, 16  
 Elder, M. D., 168  
 Ellis, Havelock, 2  
 Esquirol, 12, 386  
 Fano, 29  
 Falret, 284  
 Falta, 254  
 Farragut, 400  
 Ferenzi, 344  
 Fernald, Guy G., 6, 95, 160, 382, 389  
 Feuchtersleben, Ernst von, 14  
 Finlayson, A. W., 400  
 Fischer, B., 79  
 Flechsig, 80, 132  
 Flournoy, T., 325  
 Follett, M. P., 372  
 Fontanna, 16  
 Franz, S. I., 76, 369  
 Freud, S., 14, 55, 204, 262, 297, 339  
 Froment, J., 356  
 Fuller, Sir Bampfylde, 95  
 Galen, 4  
 Galileo, 3, 20, 366  
 Gall, 15, 71, 86  
 Ganong, W. F., 26  
 Gaskell, W. H., 53  
 Gauss, 88  
 Geddis, P., 270  
 Gerould, G. H., 367  
 Gibson, W. R. B., 200  
 Giese, 267  
 Gley, E., 253  
 Glueck, Bernard, 51, 344  
 Goethe, 23, 88  
 Goetsch, E., 258  
 Goltz, 69  
 Goodhart, S. P., 363  
 Gottlieb, R., 295  
 Grant, Madison, 377  
 Grasset, J., 43, 54  
 Green, 205  
 Gudernatsch, 254  
 Guilhermet, 238  
 Guyer, M. F., 382, 398  
 Haberman, J. B., 386  
 Haiti, S., 127, 258  
 Haldane, J. C., 35, 98  
 Halsey, J. T., 315  
 Hamilton, G. V., 134, 296  
 Hamilton, W. T., 434  
 Harteg, M., 33  
 Hatschek, E., 224  
 Head, Henry, 56, 69, 336  
 Healy, M. T., 238, 368  
 Healy, W., 238, 368  
 Heilbronner, K., 295  
 Helmholtz, 16  
 Hentig, Hans, 451  
 Hering, 20  
 Hermann, E., 325  
 Herrick, C. L., 80  
 Herrick, Judson, 70, 72, 78  
 Hesnard, A., 203  
 Heyne, A., 67  
 Hitzig, 69  
 Hobbes, 18  
 Hobhouse, L. T., 101  
 Hoffman, P., 218  
 Hollingsworth, L. S., 44, 174, 264  
 Holmes, G., 69, 348  
 Holt, E. B., 46, 164, 226  
 Hooker, Henry D., Jr., 31  
 Hopkins, A. H., 321  
 Hopson, 423  
 Horstmann, W., 113  
 Hough, T., 29  
 Howell, 423  
 Hrdlicka, A., 369  
 Hubert, Helen B., 281  
 Hug-Hellmuth, V., 145  
 Hunt, J. Ramsay, 83  
 Hurst, A. F., 293  
 Jackson, Hughlings, 22, 78  
 Jakob, 64  
 James, William, 23, 50, 190  
 Janet, P., 14, 164, 165, 197, 297  
 Jaspers, J., 185, 187  
 Jastrow, Joseph, 244, 269  
 Jelliffe, S. E., 51, 369, 392  
 Jennings, H. S., 10, 182  
 Johnson, H. M., 44, 291  
 Johnson, R. H., 265  
 Jones, Ernest, 115, 340-341  
 Jordan, H., 213  
 Jung, 14, 55, 297  
 Kahn, E., 451  
 Kant, 13, 92, 180  
 Kapper, C. U. A., 310  
 Karplus, J. P., 79  
 Keegan, J. J., 87  
 Keith, Arthur, 246  
 Kelley, C. N., 370

- Kempf, Edward J., 47, 52, 191  
 Kennedy, Foster, 355  
 Keulpe, O., 5  
 Kidd, J. L., 248  
 King, Jessie L., 282  
 Kirkpatrick, 405  
 Knowlson, T. Sharper, 206, 379, 449  
 Knowlton, F. P., 220  
 Kollarits, J., 433  
 Kreidl, 79  
 Kussmaul, 131  
 Kuttner, Alfred, 98
- Laird, John, 339  
 Lane, H. H., 43, 140  
 Langdon, F. W., 301  
 Lange, 91  
 Lapouge, G., 377  
 Laségue, 273  
 Laughlin, H. H., 369, 380  
 Lavedan, H., 271  
 Leclerc, A., 36, 286  
 Lee, Frederick S., 345  
 Leonardo, 85  
 Leopold, L., 327  
 Liébault, 14  
 Lillie, R. S., 30  
 Locke, John, 13, 18, 238, 394  
 Lodge, Sir Oliver, 323  
 Loeb, Jacques, 290  
 Logre, J. B., 237  
 Lombroso, 387  
 Lorenz, 333  
 Lyons, D. O., 268
- MacCurdy, J. T., 222  
 MacLake, William, 417  
 McComas, Howard C., 404  
 McDonald, William, Jr., 157  
 McDougall, W., 49  
 McKim, W. Duncan, 3  
 Malabbranch, E., 123  
 Maloney, W. J. M. A., 134  
 Manouvrier, L., 291  
 Marshall, Henry Rutgers, 204  
 Marten, L. J., 207  
 Mathes, P., 273-274  
 Mayer, W., 196  
 Mayor, Alfred G., 38, 337, 356  
 Mellus, E. L., 129  
 Metchnikoff, E., 314  
 Méttrier, de la, 9, 65  
 Meyer, Adolf, 48, 72, 445  
 Meyer, H. H., 295  
 Michael Angelo, 90
- Migeod, 66  
 Mill, John Stuart, 4, 5, 209  
 Miller, H. Chrichton, 15  
 Miller, R. S., 180  
 Mingazzini, G., 89  
 Minot, C. S., 312  
 Monakow, von C., 72, 77  
 Monroe, P., 433  
 Montague, W. P., 217  
 Montane, L. A., 84  
 Moore, A. R., 220  
 Morrell, 237, 386  
 Mosher, 270  
 Mott, F. W., 415  
 Mueller, Johannes, 7, 193  
 Muralt, 2  
 Myerson, A., 125, 367
- Naecke, P., 87  
 Nasher, J. L., 314  
 Nicoll, Maurice, 55, 340  
 Niessl-Mayendorf, von, 72, 74  
 Nordau, M., 387
- Olivier, 88  
 Orr, 135  
 Osborn, Henry F., 85
- Parker, G. H., 45, 161  
 Parmelee, Maurice, 99, 441  
 Pasteur, 9  
 Paton, Stewart, 4, 25, 43, 449, 453  
 Patrick, G. T. W., 409  
 Paulhan, F., 119, 179  
 Pawlow, I. P., 44, 124-125, 221  
 Perry, R. B., 100  
 Peterson, Frederick, 140  
 Pfister, 129  
 Pighini, 135  
 Pinel, 12, 17  
 Poffenberger, A. T., 44, 174  
 Potts, Fred A., 259  
 Poynter, C. W. N., 87  
 Preyer, 131  
 Pritchard, 387  
 Prince, Morton, 34  
 Putnam, James H., 434
- Radl, E., 178  
 Rainey, 140  
 Read, C., 339  
 Régis, E., 203  
 Ribot, 99, 171  
 Richardson, H. J., 210  
 Riddle, O., 259

- Rignano, E., 49, 205  
 Riley, H. A., 60, 63  
 Ritter, W. E., 11, 161  
 Rivers, W. H. R., 25, 55, 69, 355  
 Robertson, T. B., 417  
 Robinson, J. H., 25  
 Rosanoff, A. T., 373, 388  
 Rows, 135  
 Rudin, E., 388
- Santayana, G., 347-348, 451  
 Savage, O., 23  
 Schilder, P., 104  
 Schiller, 15  
 Schlessinger, M., 340  
 Schneider, E. C., 38, 416  
 Scudder, Mary T., 380  
 Semon, R., 33, 80, 126  
 Shand, 162  
 Shepherd, W. T., 64  
 Sherrington, C. S., 47, 161, 215, 221  
 Shipley, 261  
 Sidis, Boris, 113, 207, 363  
 Smith, Geoffrey, 259-260  
 Sorand, 315  
 Southard, E. E., 157, 444-447  
 Spencer, Herbert, 4, 137, 351  
 Spindler, F. M., 141  
 Spinoza, 4  
 Spitzner, A., 132  
 Spurzheim, 71  
 Stern, 151  
 Stevenson, B. L., 377  
 Stewart, S. F., 418  
 Stockard, 244  
 Stoddart, W. H. B., 301  
 Stout, G. F., 288  
 Stuart, Chapin F., 66  
 Sugita, N., 70  
 Sully, 368  
 Swingle, W. W., 255
- Tansley, A. G., 55, 264  
 Tarde, A., 119  
 Tardieu, E., 168  
 Tashiro, 32  
 Taylor, Henry Osborne, 368
- Terman, L. M., 369  
 Thiele, 333  
 Thompson, J. A., 270, 398  
 Tiedmann, 131  
 Tilney, Fred, 54, 60, 63  
 Timme, W., 401  
 Titchner, E. B., 111  
 Torrey, H. B., 26
- Van der Veer, A., 296  
 Vanwoerkon, W., 223  
 Varisco, B., 111  
 Verdi, 88  
 Verworn, M., 197  
 Vincent, Stella B., 69  
 Von Niessl-Mayendorf, E., 111  
 Von Wieg-Wickenthal, K. E., 305
- Wagner, 153  
 Wallin, J. E. W., 415  
 Walsche, F. N. R., 223  
 Ward, James, 50, 123, 134, 137, 228  
 Warren, Howard C., 94, 160, 211, 346  
 Washburn, M. F., 330, 423  
 Watson, J. B., 50, 84, 94, 263, 278, 385  
 Weber, F., 256  
 Weiss, A. P., 102, 342  
 Wells, F. L., 370  
 Werter, 430  
 Westermark, 243  
 Wetterstrand, 14  
 Wheeler, M. S., 110  
 Wheeler, W. M., 290  
 Wheelon, H., 261  
 Whipple, G. G., 253  
 White, W. A., 49, 51, 440  
 Whitman, 258  
 Wohlgemuth, A., 170  
 Woodworth, 343, 371  
 Woody, C., 434  
 Wright, Almroth F., 271  
 Wulzen, R., 258
- Yerkes, R. M., 84, 114, 286
- Ziegler, 131

## TOPICAL INDEX

- Abstraction, process of, 198  
Academic mind, 348  
Achievement, sense of, 343-344  
Action, engraphic, 183  
Activation, tide of, 164  
Activity, mental, relation to general, 36; muscular, memories of, 46, 72; reciprocal, 106  
Accustomedness, 295  
Adaptation, as process, 26; process of, 29; of organisms, 39; capacity for, 60; instinctive, relation of nervous system to, 169  
Adenoids, effect of on mental processes, 235  
Adequacy, complex, 345-349  
Adjustment, mechanism of, 21; relation to environment, 33; special mechanism of, 39, 43; vegetative level, 51; physico-chemical, 51; sensori-motor, 51; psychic or symbolic, 51; automatic, importance of, 299  
Adjustors, 45  
Adrenalin, effect of, 261  
Adrenals, ductless glands, 253  
Age, old, significance of, 311-316; old, and childhood, security of, 318; old, normal, 331  
Agonist, 222  
Altitude, changes due to, 38  
Ambivalence, 283  
Amœba, 46  
Amphioxus, 60  
Anæsthesia, 176  
Analysis, elemental, 8; nature's, 21  
Analysts, dogmatism of, 162  
Analyzers, 58  
Anatomy, comparative, 58  
Ancestor, human, 66  
Antagonist, 222  
Antipathies, 155; early, 432-433  
Antixenism, 168  
Apes, higher, 64, 84; anthropoid, 65, 92  
Apparatus, auditory, 44; sensori-motor, 47  
Apraxia, 223  
Arc, reflex, concept of, 78; heterodetic, 182; homeodetic, 182  
Archeopallium, 58, 215  
Areas, silent, 73; Franz motor, 76  
Association, 51; psychology, 178; primitive forms of, 187  
Attention, 233; stream of, 430  
Attitudes, hedonic, 160  
Autantitypy, 134  
Authority, feeling of, 344  
Autismus, 238  
Auto-catalysis, 31  
Autocoids, 163  
Automatism, 159; of speech, 289  
Automatization, 232  
Autotopnosia, achiria, 116  
Aviator, 231  
Baby, comparison of chick to, 127; first cries of, 142  
Bathism, 318  
Behavior, 50; as function, 51; higher and lower animals compared, 225; human, centres for study of, 448-449  
Belief and conduct, 365-366  
Bicêtre, Hospital of, 12  
Binet-Simon tests, 420  
Biochemistry, development of, 16  
Biotaxis, neuro, 62  
Bio-tonus, 305  
Birds, vision of, 67-68; mating of, 68  
Blood pressure (see cardiovascular system), 257  
Brain, human, complexity of, 10; higher and lower centres, 23; original, 58-59; old, 58; evolution of, 61; weight of, 64; cebus-chimpanzee, 64; of mud-puppy, 70; structure and function in, 80; Caucasian, 87; Negro, 87; convolutions of, 87; weight of, 87; of American Indian, 87; bilateral symmetry of, 87; at birth, 128; woman's, 128-260; man's, 128; stages in development of, 129; relation of structure to function, 248; cellular changes in

- old age, 319-320; new, functions of, 335; old, functions of, 336
- Capacity of individual, 24
- Cardiovascular system, irritability of, 261
- Castration, effects of, 262
- Causation, law of, 36
- Cell, organization of, 31
- Censorship, 323
- Centres of control, 53; brain, higher, 57; brain, lower, 81; of perception, 131; of conception, 131
- CEPTORS, extero, 134, 215; proprio, 134, 215; intero, 134
- Cerebral hemispheres, 128
- Cerebrum, specific functions of, 106
- Character, 244; stability of, 435
- Character, science of, 5, 209; integral mentality function, 6, 160-382; dynamic side of personality, 95; foundations of, 162
- Chemotaxis, 46
- Children, neurotic, 288, 413-416; reaction of in emergency, 424-425
- Chimpanzee, 61; intelligence of, 64, 84, 101
- Circulation, relation of to mental processes, 256
- Climacterium, 321
- Co-education, 270
- Cœlenterates, 45
- Cœnesthesia, 137
- Collectivism, 24
- Complex, 34
- Conception, elemental, 163; organismal, 163
- Conduction, 279
- Conflict, idea of, 203, 332, 337, 354; of opinion, 365, 428
- Conscious, fore, 204
- Consciousness, conception of, 49; as entity, 50; stream of, 50; and sub-conscious activities, 55; consecutive, 59; primitive, 69; marks, fluctuation, equilibrium, 81; moment, 113, 207; self, 115; a process, not a state, 118; self, dawn of, 144, 147, 154; importance of, 404
- Contractions, rhythmic, 29
- Control, motor, 76; emotional, 135
- Convolutions, physiology of, 76
- Co-ordination, 51, 194
- Cord, spinal, 56
- Correlation, structure and function, 51, 137-140
- Cortex, cerebral, 62, 63, 70, 71, 78, 105, 130, 248; structure of, 64; mammalian, 64; cerebral, nerve cells in, 65; cerebral, removal of, 69; of white rat, 70; layers of, 74; comparison of, 76; relation to sub-cortical centres, 293; cerebral, infant without, 78; functional capacity, 130; reciprocal, innovation of, 223; functions of, 224
- Crazes, 3
- Cretinism, 259
- Cro-magnon, 96
- Culture, 434-435
- Daphniæ, reactions of, 290
- d'Arc, Jeanne, sexual life of, 265
- Death, 42
- Defense reaction, 202
- Degeneracy, 386-389
- Dementia præcox, inheritance of, 388
- Democracy, phases of, 326
- Depersonalization, 117
- Depression, state of, 112
- Desire, repression of, 165; direction of, 201; driving power of, 227; wandering of, 355
- Development, phylogenetic, 61; sexual, male and female, 258
- Discrimination, 81; spacial, 82
- Disposition, 244
- Dissociation, 163; relation to physical disorders, 332
- Docility, nemesis of, 349
- Dock family, 400
- Dogs, blind and normal, 44, 76
- Dreams, psychology of, 341
- Drives, three primitive, 32
- Dualism, 20, 56
- Eccentricities of behavior, 329
- Echolalia, 107
- Education, 3; probable effects of, 130; aim of, 272; relation of learning to, 394; object of, 395-398
- Effectors, 45, 58
- Effort, 148; sense of, 230
- Egotism, 322-324; significance of, 346; in German philosophers, 347
- Embarrassment, 350
- Embiontic, 130
- Embryo, development of, 41, 219; vertebrate, 42; impulses of, 134

- Emotional control, 256-257  
 Emotions, of men and women, 265-269; of boys and girls, 267  
 Encephalon, tel-, di-, mes-, myel-, 59  
 Endocrine organs, relation to personality, 91, 254-257  
 Endowments, mental, 158  
 Energy, reserve, 30; accumulation of, 31; transference, transformation, 43; stream of, 46, 165; assimilation and storing of, 47  
 Engrams, 33, 34  
 Epinephrin, 253  
 Epochs, important in study of brain, 7; modern, 8; of life, specific factors of, 309  
 Equilibrium, unstable, 30, 31; system in, 31; shift in, 50; of organism, 192; relation of to internal organs, 253  
 Erotism, 256  
 Ethics, arbitrary standards, 24; science of, 180  
 Ethology, 5, 209  
 Eunuchs, traits of, 261  
 Euphoria, 188, 195  
 Evaluation, choice, 216  
 Evolution, idea of, 12; dissolution, 23  
 Excitation, 66  
 Exhilaration, state of, 112  
 Existence, consciousness of, 117  
 Experience, broader fields of, 63; proprio-ceptive forms of, 99; continuum, 287  
 Expression, movements concerned in, 142  
 Extrovert, 102  
  
 Facilitation, 292  
 Factors, heterotrophic-autotrophic, 33  
 Fads, 3  
 Failure in living, 24  
 Fatigue, signs of, 230-231, 236, 344, 422  
 Fear and hope, 23; rage, 177  
 Fluid, cerebro-spinal, 67  
 Forces, equilibrium of, 33; anabolic, catabolic, 168  
 France, women in, 271  
 Freedom, 25  
 Freud, S., criticism of, 355  
 Function, antixenic, 29, 42; specific, 40; evolution of, 41; consideration of, 54; localization of in brain, 74; specific, 145  
  
 Garrulity of old people, 322  
 Genius, 85, 86, 88; explanation of, 89; analysis of, 90  
 Geriatrics, 315  
 Germany, 450-452  
 Gibbon, 76  
 Gonadectomy, 260  
 Gorilla, 65, 76  
 Growth, rate of, 258  
 Guinea-pig, 92  
  
 Habit and memory, 172; important in co-ordination, 194; formation of, 278; creatures of, 279; relation to structure, 280; formation of in embryo, 281-282; levels in formation of, 287; classification of, 288; relation of brain weight to, 292; relation of perception, 293; men, apes, dogs, and cats compared, 297; importance of various functions in formation of, 299-300; importance of biologic view of, 304; regular, 401; bad mental, 408  
 Habituation, 296  
 Hand-shake, 301  
 Health, 48  
 Hemispheres, cerebral, removal of, 79, 294  
 Heredity, influence of on personality, 378-382; and environment, influence of, 383-385; psychological, 385  
 Homophony, 34, 184  
 Human beings, study of, 25  
 Hypnotic states, 188  
 Hypotaxis, 156  
 Hysteria, 293  
  
 Idealism, 346  
 Identity, personal, 115  
 Idiokinesis, 168  
 Imitation, 35  
 Impressions, capacity to reproduce, 34; from different organs, 137  
 Imprints, 33, 34  
 Impulses, pure motor, 75; organization of, 189  
 Inadequacy, sense of, 352  
 Indifference, primary and secondary, 33  
 Individual, unity of, 9; variations, 370  
 Individualism, 24  
 Industry, mental hygiene of, 447  
 Infantilism, causes of, 273-275  
 Inhibition, 66, 213, 220-225; in adult,

- 214; of vertebrates, 218; of invertebrates, 218; vagal, 219; relation to excitation, 226; effect of, 403-404
- Innervation, tonic, 223
- Insanity, 11
- Insects, 44; adaptability of, 63
- Instinct, 339, 427; criminal, 194
- Integration, 178
- Intellect, without emotion, 180
- Intelligence, 65; relation of internal secretions to, 91; secret of, 211, 225; tests, value of, 373-376
- Interference, meddlesome, 411-412
- Introvert, 102
- Inventory, educational progress, 420-421
- Investigation, spirit of, 26
- Involution, 313
- Irritability, special form of, 30
- Jellyfish, 37, 38; habits of, 280-281
- Jews, psychology of, 367
- Justice, antiquated system of, 243
- Kinesthesia, 137
- Kleronomic, 130
- Lancet, London*, 76
- Language, use of, 179
- Laziness, 166
- Leaders, revolutionary, 451, 452
- Learning, rate of, 44; capacity of man, of woman, 268; processes, 279
- Lenine, 453
- Levels, 22; conscious and unconscious, 56; shifting of, 107
- Libido, 355
- Life, science of, 19; efficient and happy, 23; process of adjustment, 26; intersection of two sets of factors, 39; curve, 308; mental, protection of, 445
- Light, sensitiveness to, 60
- Living, formula for, 3
- Localization, idea of, 71; narrow concept of, 74, 80; restricted, 77
- Localizationists, 76
- Longevity, 312
- Lying, in children, 238-240
- Man, detachable mechanism, 6; own worst enemy, 24; contrasted with lower animals, 57; primitive, 57; evolution of, 58; modern, 61; supremacy of, due to, 83; civilized, 92; inner, 342
- Mechanism, primitive, 45; as habit, 143
- Mechanisms, controlling, 213
- Medullation, 80
- Memory, unconscious, 20, 34; organic, 35, 36, 172; psychologic, 35; organic and psychological, 151; psychologic, mechanism of, 151; infantile, 153; disorders of, 172
- Menopause, emotional changes during, 263
- Mental and physical, contrasts of, 48
- Metabolism, 47; relation of to personality, 127
- Mind, hypothetical states of, 5; human, specific differences, 11; and body, relations of, 36; subcutaneous, 100; reacts desideratively, 100; in evolution, 101; psychological theory of, 173; organic synthesis, 180; creative, 206; and body, 272; mediæval, 369
- Mneme, 182
- Mnemonic phenomena, 182
- Moments, desultory, 208
- Monist, 20
- Motivation, 225
- Motives, conflict of, 148-149; personal and impersonal, 348
- Motor, set, 230; impulses, importance of, 367
- Mouse, 92
- Movements, primitive, muscular, 73; sucking, 148; and imagery, 330
- Muscle, preparedness for action, 136; striated and unstriated, 148; relation to thinking, 219, 338
- Myopia, spiritual, 48
- Mysticism, 342-346, 360
- Mystics, dogmatism of, 162
- Napoleon, 90
- Narcosis, 198
- Nations, health and happiness of, 9
- Nature, human, 2; study, value of, 436
- Negativism, 113
- Negro, 246; mental efficiency of, 276-277; emotions of, 276-277; mental characteristics of, 276-277; brain of, 276-277; intelligence of, 276-277
- Nelson, 399
- Neopallium, 59, 336



- Nerve cell, small pyramidal, 74; large pyramidal, 74; volume of, 130
- Nerves, 16
- Nervous baby, 401
- Nervous system, 21; introduction of, 32, 39; importance of, 40; functions of, 42; organisms without, 45; vegetative, 52; involuntary, 53
- Nervousness, of baby, 406-407; American, 410-411
- Neurism, 318
- Neurogram, 34
- Neurology, comparative, 69
- Neurotic, constitution, 333
- New Guinea, 93
- Newton, Sir Isaac, 3, 90
- One's self, finding, 133
- Ontogeny, 193
- Orang-outang, 65, 84, 101
- Organs, sense (see receptors), 43; selective activity of, 175
- Organism, living, 31; a system, 31; struggle of, 42; unity of, 161
- Organization, extension or limitation of, 55, 160; and personality, 199; and character, 200
- Orientation, 141
- Ovaries, effect of transplantation, 258
- Pacifist, 363-364
- Palæncephalon, 130
- Parataxis, 156
- Parliament, House of, 78
- Peace, 25
- Peculiarity, mental, of Anglo-Saxon, 2
- Pedigree, chart, 381
- Periodicity, functional in women, 264-282
- Personality, autonomic functions and, 47; human, integration of, 54; complex of, 94; simple and complex, 95; represents deposits of history, 96; inherited qualities, 97; methods of studying, 97, 368; problem, 98; physical basis of psychological, 99; synthesis of, 99, 102, 307; civilized, 101; diagonal parallelogram of forces, 102; bundle theory of, 103; background of, 103; biological distinctions of, 104; sense of, 105; and individuality, 105; and environment, 107; sensory impressions, 108; loss of, 110; sejunction of, 111; consciousness of, 115; development of, 121; epochs in development of, 122; genesis of, 132; all-round, 195; types of, 245-248; involution of, 307; psycho-neurotic, biography of, 357-363; multiple, 363; biological organization of, 390; practical examination of, 391; indifference to study of, 447-448; study of to prevent war, 449; psychopathic, 451-452
- Phenomena, mnemonic, 34
- Philosophy, interpretation of, 3; speculative vagaries of, 4
- Phototaxis, 290
- Phrenism, 318
- Phrenology, 15, 86
- Phylogeny, 193
- Physicians, mind of, 4; postural, 81
- Physiology, debts to modern, 7
- Pithiatism, 356
- Pithecanthropus erectus, 65
- Pituitary body, relation of to growth, 258
- Plasticity, sign of life and function, 37
- Plato, 3
- Play, importance of, 409
- Pleasure-pain, 170
- Polarization, electrical, 31
- Posture, effects of, 274; of school children, 274; importance of, 301, 338, 414
- Power, regulatory, 28
- Predisposition, factors determining, 244
- Preparedness, state of, 164
- Preservation, 289-297
- Pressure, sense of, 82
- Prestige, 327-329
- Pride, 56
- Processes, highest mental, of man, 10; mental, polarity of, 112; compensatory, 114; of co-ordination, 124; of correlation, 124; of association, 124; relation of physical and mental, 351
- Proprio-ceptors, 43
- Protection, 41
- Protopathic, 336
- Protozoa, activities of, 10, 40
- Psychasthenia, 257
- Psychiatric Clinic, University of Michigan, 449
- Psychiatry, development of, 14, 446
- Psychic, concept of, 40, 305
- Psychologist, academic, 98
- Psychology, objective, 48; social, 49

- Psychobiology, 48  
 Psycho-motor, irritability, 285  
 Puberty, emotional changes during, 263, 427  
 Pulsation, cause of, 38
- Racial qualities, 376-378  
 Range, visual, in neurotics, 350  
 Raphael, skull of, 89  
 Rat, white, behavior of, 69; habits of, 281; relation of brain to habits, 291  
 Rationalization of conflict, 362  
 Reaction, specificity (reversible chemical), 28; circular, 32, 33; defensive, 42, 73, 429-432; primitive, 43; outcome, 183; voluntary, 217; voluntary, relation of nervous system to, 229  
 Reactions, voluntary, 230; voluntary, influence of emotional processes, 234; muscular, thwarted integration of, 336-337  
 Reality, corrective, 98; principle of, 120  
 Reason, sanctity of, 7  
 Recency, factor, 330  
 Receptors, 43, 58  
 Reflex, behavior, unit of, 40  
 Relationship association, 187  
 Relaxation, psychology of, 409  
 Repetition of acts, effect of, 290  
 Repression, 207, 355  
 Response, adaptive, 92  
 Retentiveness, 35  
 Revolution, French, 13  
 Rhythm of reactions, 282  
 Rousseau, J. J., 122
- Satisfaction, pleasurable, 196  
 Savagery, 92  
 Savant, before moralist, 19  
 Savonarola, 366  
 Secretions, internal, relation of to emotions, 163  
 Sejunction, 353  
 Self, knowledge, 99  
 Senescence, 308  
 Sensation, tactile, 82; organic, 111; epicritic, 196, 336  
 Sense, kinesthetic, 44; muscular, 44; static, 109; somatognostic, 115; autosomatognostic, 115  
 Senses, comparison of, 175
- Sensibility, protopathic, 55-56; epicritic, 55-56  
 Sensitivity, differential, 28; range of, 41, 44  
 Sensitization, hyper-, 296  
 Servetus, 366  
 Sex diseases, 259; Freudian conception of, 262; psychology of, 265-266; distinguishing traits, 269-271  
 Shakespeare, 85, 212  
 Shell shock, 303, 355-357  
 Shock, war, 168; physical, effects of, 356  
 Sleep, 188, 221  
 Snail, 34  
 Socrates, 1, 3  
 Soul, organ of, 16  
 Sounds, training and detecting, 294  
 Speech, imitation, 107; development of, 155; of parrots, 186; of idiots, 186  
 Spelling, 423  
 Sponge, 43, 45  
 Staleness, signs of, 231  
 Stimulus, 31; stimuli, beneficial and harmful, 33, 50; nature of, 184  
 Stone age, 85  
 Subconscious, 55, 203  
 Sublimation, 207; of sexual instincts, 263, 299  
 Success and failure, 425-426  
 Suggestibility, 14, 293  
 Suppression, 207  
 Symbol, 367  
 Symbolization, 340-343  
 Synesthesia, 174  
 Synthesis, 160, 222  
 System, nervous, 21; nervous, introduction of, 32, 39; nervous, importance of, 40; nervous, functions of, 41, 42; autonomic, 42, 43; muscular, 45; nervous, organisms without projicient, 45, 47; nervous, vegetative, 52; nervous, involuntary, 53; Pallidal, 82; nervous, of invertebrates, 213; nervous, sympathetic, 135, 216, 251; nervous, autonomous, 216, 333-334; nervous relation of to behavior, 247; nervous, sensori-motor, 250; nervous, sympathetic, relation of to consciousness, 275
- Tadpole, 39; effects of feeding on, 254  
 Taste, sense of, 44, 174

- Temperament, 160; character, 169, 244; artistic, 360-362  
 Tendencies, conative, 228  
 Thalamus, 69; optic, functions of, 82  
 Thalassophilia, 380  
 Thought, extreme, 97; power, 97; rational, 97  
 Thymus gland, 258  
 Thyroid gland, 253; gland, functions of, 258-259; gland, in woman, 261  
 Tic, 298-302  
 Tolerance, 295  
 Tone perception, in man, 141  
 Tonus, of muscles, 82, 136; normal, 222  
 Topinard, 377  
 Touch, relation of to mental life, 291  
 Tracts, nervous, 110; kleronomic, 110; embiontic, 110; nerve, 130  
 Traits, 244  
 Types, hair trigger, 210, 370; dolicho-, cephalic-, nordic-, 377-378  
  
 Unconscious, 34  
 Union, monogamous, 68  
 Universities, American, limitations of, 437  
  
 Unrest, era of, 3  
 Uplift, social, purpose for, 2  
  
 Vago-sympathetic system, 249  
 Valuation, 225-228  
 Vertebrate, 47; lower, 58; primitive, 60; early life of, 146  
 Vesalius, 6, 7  
 Vesuvius, 181  
 Visceral mechanisms, 177  
 Vocabulary, early, 155; growth of, 156  
 Volition, 225-226  
 Volitional response, early, 149  
 Voltaire, 13  
  
 War, 25, 440-443  
 Waves, sound, 44  
 Weber, law of, 37, 218  
 Weight, discrimination of, 82; and stature, ratio of, 417-418  
 Will, 53, 225; disorders of, 234; freedom of, 239-243  
 Wilson, E. B., 9  
 Wilson, S. A. R., 223  
 Wish, 53; Freudian, 46  
 Worry, 231  
  
 Zoospores, 280









RETURN TO the circulation desk of any  
University of California Library  
or to the

NORTHERN REGIONAL LIBRARY FACILITY  
Bldg. 400, Richmond Field Station  
University of California  
Richmond, CA 94804-4698

---

ALL BOOKS MAY BE RECALLED AFTER 7 DAYS  
2-month loans may be renewed by calling  
(415) 642-6233

1-year loans may be recharged by bringing books  
to NRLF

Renewals and recharges may be made 4 days  
prior to due date

---

DUE AS STAMPED BELOW

---

OCT 18 1989

---

FEB 18 1990

---

MAY 08 1990

---

Santa Cruz Jitney

---

JUL 11 1999  
APR 14 2000

---

---

---



600

1100



445210

Paton

BJ45

P3

Cop. 2

UNIVERSITY OF CALIFORNIA LIBRARY

